

ALBERT R. MANN
LIBRARY

NEW YORK STATE COLLEGES
OF
AGRICULTURE AND HOME ECONOMICS



AT
CORNELL UNIVERSITY

Cornell University Library
TS 1315.W3

The story of textiles : a bird's-eye view



3 1924 003 602 863

mans

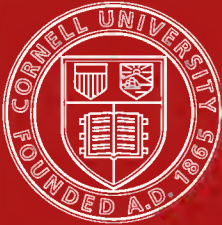

Cornell University
Library

The original of this book is in
the Cornell University Library.

There are no known copyright restrictions in
the United States on the use of the text.

<http://www.archive.org/details/cu31924003602863>

THE STORY OF TEXTILES

THE STORY OF TEXTILES

A BIRD'S-EYE VIEW OF THE HISTORY
OF THE BEGINNING AND THE
GROWTH OF THE INDUSTRY
BY WHICH MANKIND
IS CLOTHED

BY
PERRY WALTON

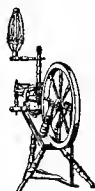

COMPILED AND WRITTEN FOR
JOHN S. LAWRENCE
BOSTON, MASS.

COPYRIGHTED 1912
BY JOHN S. LAWRENCE

COMPILED, WRITTEN, AND PRINTED BY DIRECTION OF THE
WALTON ADVERTISING AND PRINTING COMPANY,
BOSTON, MASSACHUSETTS

FOREWORD

As clothing has from time immemorial been one of man's necessities and almost as essential to his welfare as food, it is not surprising that the textile industry has long in value of output been second only to the production of food-stuffs. Important, however, as the industry is, its history, so far as the writer knows, has never, at least in America, been published. Aside from its importance the industry possesses much of interest not only for the student, but also for the man of affairs. Different branches of the industry, such as wool, silk, cotton, and linen, have been treated separately, but nothing has been written about the origin and growth of the industry as a whole.

This book, of which some explanation is necessary, is an effort to fill this gap. Although a complete history of the industry has not been the aim of the writer nor the desire of the publisher, the purpose has been to present to those interested in the textile industry a bird's-eye view of the leading facts which have marked the progress of the industry up to the firm establishment of the manufacture of textiles on American soil, together with such intervening facts as are necessary to give one a comprehensive view of the subject.

The book deals largely with the development in England and America, because in these two countries originated the inventions that have brought the industry to its present efficiency, and in them also was evolved the factory system

which has so greatly revolutionized social life in England and America.

All of the facts have been verified by careful investigation, some of which has gone back to original sources. As far as it goes, this brief history endeavors to be authoritative and comprehensive. Much attention is given to the American development, particularly that relating to the cotton industry.

To cover the subject as it deserves would require more space than could be contained in a single volume. And, while a more complete history might be more interesting to the student, it would be less so to the textile man for whom this has been primarily written, because of the necessary introduction of a mass of minor details that would be too tedious for him to peruse. The writer hopes that the man interested in the textile business, whether he be a manufacturer or a clerk behind the counter, may obtain from these pages a clear view of the development of America's leading industry, without having to give the subject the time that a fuller narrative would require.

Mr. John S. Lawrence, for whom this book has been prepared and by whom it is published, is a partner of the firm of Lawrence & Co., one of the largest commission houses for the distribution of textile products in America. Many of its former members have filled important places in the establishment of the industry in the great textile centres of America.

The writer desires to acknowledge the courtesy shown in facilitating the preparation of this book by C. J. H. Woodbury, Sc.D., secretary of the National Association of Cotton Manufacturers; L. W. Jenkins, Curator of Ethnology, Peabody Museum, Salem, Mass.; W. P. Wilson, Sc.D., Director Commercial Museum, Philadelphia; Miss

S. G. Flint, of the Textile Department of the Museum of Fine Arts, Boston, Mass.; and also to acknowledge his indebtedness to the following authorities: "Silk Industry in America," by L. P. Brockett; "Manual of Power," by Samuel Webber; "Loom and Spindle," by Mrs. Harriet Hanson Robinson; "Illustrated History of Lowell," by Charles Cowley; "Introduction of the Power Loom and Origin of Lowell," by Nathan Appleton; "Draper's Dictionary," by W. Beck; "The American Cotton Industry," by T. M. Young; "Introduction and Early Progress of the Cotton Manufacture in the United States," by Samuel Batchelder; "The Textile Industries of the United States," by William R. Bagnall; "History of the Cotton Manufacture in Great Britain," by Edward Baines; "Fabrilla: A Substitute for Cotton," by Stephen Merrill Allen; "Historical Sketch of the Town of Pawtucket," by Rev. Massena Goodrich; "The First Cotton Mill in America" (in Essex Institute Historical Collections), by Robert S. Rantoul; "A Compendious History of the Cotton Manufacture," by Richard Guest; "History of Lynn," by A. Lewis and J. R. Newhall; "Economic and Social History of New England," by William B. Weeden; "Lancashire Worthies," by Francis Espinasse; "Brief Biographies of Inventors of Machines for Textile Fabrics," by Bennet Woodcroft; "Life and Times of Samuel Crompton," by G. J. French; "Memoir of Cartwright," by his daughter; "History of Lawrence," compiled by H. A. Wadsworth; "Annals of Providence," by William R. Staples; "History of New Bedford," by Leonard Bolles Ellis; "History of Manchester," by Maurice D. Clarke; "The Cotton Industry," by W. B. Hammond; "The Cotton Manufacture of Great Britain," by Andrew Ure; "Memoir of Patrick Tracy Jackson," by John A. Lowell; "Memoir of Samuel Slater,"

by George S. White; "Memoir of Eli Whitney," by Denson Olmstead; "The Factory," by Jonathan Thayer Lincoln; "State of Rhode Island and Providence Plantations at the End of the Century," by Edward Field; "History of Philadelphia," by Scharf and Westcott; Chambers's "Book of Days"; "A Comprehensive History of the Woolen and Worsted Manufactures," by James Bischoff; and "History of Manufactures," by Bishop; also "The Report of the Tariff Board on Schedule K" and articles in the *Encyclopædia Britannica*, *Universal Encyclopædia*, *Encyclopædia Americana*, the *Textile Manufacturers' Journal*, the *Textile World Record*, the *Fall River Herald*, the *Fall River News*, and the various census reports relating to linen, wool, cotton, and silk.

Thanks are also due The Macmillan Company and the Houghton Mifflin Company for permission to use reproductions of illustrations from their publications; also to Job L. Spencer for the illustration of the Old Slater Mill, from a sketch by his son; to the Rhode Island Historical Society for the courtesy extended in securing the portrait of Moses Brown; to the New Haven Colony Historical Society for the portrait of Eli Whitney; and for the facilities extended in the preparation of this work by The Commercial Museum, Philadelphia; A. H. Baldwin, Chief of the Bureau of the Department of Commerce and Labor, Washington, D.C.; Dr. F. H. Bowman, of Manchester, England; Miss Henrietta C. Cattanach; Miss N. L. Kingman; George R. King; Chicopee Manufacturing Company, Chicopee Falls, Mass.; the Draper Company, Hopedale, Mass.; and to Potomska Mills, New Bedford, Mass.

CONTENTS

	PAGE
CHAPTER I	
BEGINNING OF TEXTILES	13
Prehistoric Evidences of the Art—Textile Industry among the Ancients—Early Existence in North and South America—The West's Textile Indebtedness to the East.	
CHAPTER II	
FLAX, LINEN, WOOL, COTTON, AND SILK	24
Flax and Linen—History of Linen—Production of Flax and Linen—Wool—Efforts to improve Wool—Early Use of Wool—Cotton, the Plant, Growth, and Distribution—Early History—Columbus and Cotton—Silk—Early History of Silk—Silk Industry in America.	
CHAPTER III	
FACTORY SYSTEM	59
Growth of the Factory System—Earliest Record of English Factory—English Names derived from Industry—Causes of the Concentration in Lancaster—Separation of Agriculture and Spinning and Weaving—Early Relationship of Employer and Employee—Inventions and the Factory System—Influence of Factory on English Social Life.	
CHAPTER IV	
ERA OF INVENTION	71
Era of Invention—Early Improvements in Textile Machinery—John Kay—Paul and Wyatt—James Hargreaves—Richard Arkwright—Samuel Crompton—Edmund Cartwright—Inventions of Knitting Machines—Ipswich Mills—Joseph Marie Charles Jacquard—Machines for spinning Flax—James Watt—Eli Whitney—Improvements of the Basic Machines, and Further Inventions—Bleaching—Dyeing—Printing—Mercerizing Process.	

CHAPTER V

AMERICAN INDUSTRY BEFORE THE REVOLUTION 122

American Industry—Earliest Traces of the Industry—Fostering Legislation—First Cloth made and First Mill erected at Rowley—Slave Traffic and Importations—English Efforts to hamper the Industry—First Worsted Mill—Skill attained in Textile Work—Bounties and Monopolies to stimulate the Industry—The Spinning Craze—Approach of the Revolution—Improvements in English Textile Machinery—Condition of the Market immediately after the Revolution—American Effort to secure English Machines—England and Cotton—Starting of Cotton Cultivation in the South—Origin of Sea Island Cotton and Beginning of its Cultivation in the South.

CHAPTER VI

AMERICAN INDUSTRY AFTER THE REVOLUTION AND BEFORE SLATER 148

First Manufacturing in Pennsylvania—First Cotton Mill in New England—First Textile Trade-mark—First Textile Advertising—Boston Sail Cloth Factory—Commencement of the Cotton Industry in Rhode Island—First Woolen Mill—Washington inaugurated in Suit of Domestic Woolen—First Woolen Mill operated with Power Machinery.

CHAPTER VII

ERA OF SAMUEL SLATER 168

Slater's Arrival in America—Goes to Providence—Starts First Cotton Mill with Arkwright's Machines in America—Payment and Discipline of Employees—Starts his Second Mill; the First with Arkwright Machinery in Massachusetts—First Commission Houses—Shepard starts Mill at Wrentham—Other Mills start—Whittenton Cotton Mills—Start of the Industry in Connecticut—Spread of Industry through Influence of Slater—Gilmore's Loom—Beginning of Power Woolen Mills in Rhode Island—Southern Development.

CONTENTS

9

PAGE

CHAPTER VIII

ERA OF LOWELL, APPLETON, MOODY, JACKSON, AND BOOTT, 192

First Complete Cotton Mill in the World—Lowell visits English Mills—Organization of the Boston Manufacturing Company—Care of Employees—Sale of Goods—Waltham *versus* Rhode Island System of Manufacturing—The Foundation of the City of Lowell and the Starting of the Merrimac Manufacturing Company—Naming of Lowell—Starting of First Mills.

CHAPTER IX

OTHER TEXTILE CENTRES 210

Philadelphia the Greatest Textile-producing City of America—Silk Industry in Philadelphia—Development of the Woolen Industry—Textile Machinery—Carpet Industry—Later Growth—Foundation of Lawrence—Beginning of Fall River—Colonel Durfee's Mill—The Troy and Fall River Mills—Early Looms, Work, and Wages—Other Companies—Providence—Paterson, N.J.—New Bedford—Manchester—Amoskeag lays out a Town—New York—Amsterdam—Woonsocket, R.I.—Conclusion.

INDEX 253

ERRATA 275

ILLUSTRATIONS

AMERICAN INDIAN WEAVING	<i>Frontispiece</i>
	<i>Facing Page</i>
WARRIOR OF GILBERT ISLANDS, SOUTH PACIFIC OCEAN . .	13
GREEK AND ROMAN METHOD OF SPINNING AND WEAVING .	16
NAVAJO WOMAN MAKING YARN OF NATIVE WOOL	20
SPECIMENS OF NORTH DAKOTA GROWN RUSSIAN SEED- FLAX; CUTTING HEMP	24
LINEN MUMMY CLOTHS	28
EGYPTIAN TUNIC; PERUVIAN TUNIC	32
THE COTTON PLANT	36
FABRICS WOVEN BY THE BAKUBA TRIBE	40
THE EGGS, CATERPILLAR, COCOONS AND MOTH OF THE SILKWORM	44
ENLARGED REPRODUCTIONS OF TEXTILE FIBRES	48
JAPANESE SPINNING AND WEAVING	52
THE MULE	56
ANCIENT EGYPTIANS SPINNING AND WEAVING	60
BOWING OF COTTON, AS PRACTISED IN INDIA AND CHINA; A HINDU WOMAN SPINNING COTTON YARN ON THE PRIMITIVE WHEEL OF INDIA	64
DOMESTIC FLAX WHEEL; HINDU SPINNING AND WEAVING, HINDU WEAVER AT HIS LOOM	72
JOHN KAY	76
SIR RICHARD ARKWRIGHT	80
SAMUEL CROMPTON	84
DR. EDMUND CARTWRIGHT	88
CARTWRIGHT'S LOOM	92
AMOS A. LAWRENCE	96

	<i>Facing Page</i>
ELI WHITNEY	100
DISTAFF SPINNING	106
HANDICRAFT CARDING, ROVING, AND SPINNING BY THE HAND WHEEL	112
PEG WARPING	118
WARPING	124
THE LOOM THAT PRECEDED THE POWER LOOM	130
HIGH'S JENNY	136
THE IMPROVED JENNY	142
A HANDICRAFT WEAVER AT HER LOOM	148
ARKWRIGHT'S ORIGINAL WATER FRAME WITH THE SPECIFI- CATIONS ON THE ORIGINAL PATENT PAPERS TAKEN OUT BY HIM ON JULY 15, 1769	154
THE OLD SLATER MILL, PAWTUCKET, R. I.	160
CARDING, DRAWING, AND ROVING AS IT WAS IN SAMUEL SLATER'S EARLY MILLS	166
SAMUEL SLATER	172
MOSES BROWN	178
WASHINGTON'S VISIT TO THE FIRST COTTON MILL AT BEVERLY, MASS., OCT. 30, 1789	184
FRANCIS C. LOWELL	190
NATHAN APPLETON	196
P. T. JACKSON	202
A MODERN MULE SPINNING-ROOM	208
SAMUEL WETHERILL	214
ABBOTT LAWRENCE	220
INTERIOR VIEW OF A MODERN RING SPINNING-MILL	226
AMOS LAWRENCE	232
INTERIOR VIEW OF A MODERN WEAVE-ROOM	238
MODERN AUTOMATIC NORTHROP LOOMS	244

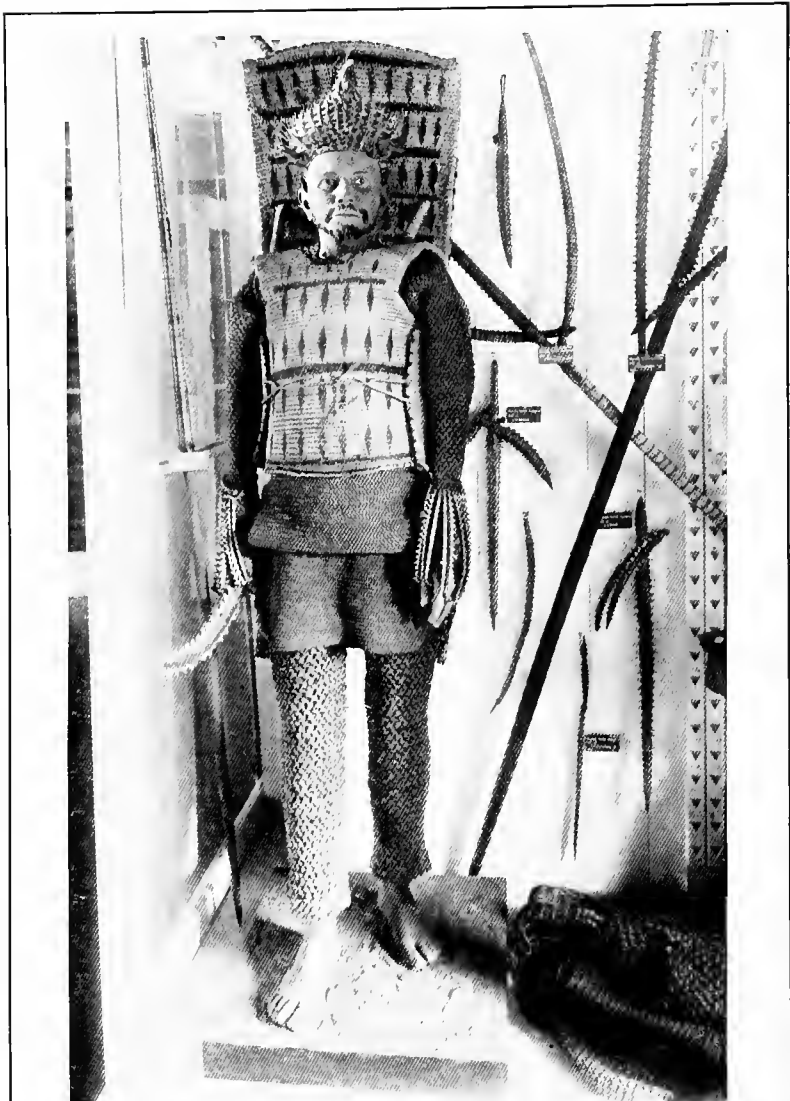

WARRIOR OF THE GILBERT ISLANDS, SOUTH PACIFIC OCEAN

(From an Exhibit in the Peabody Museum, Salem, Mass.)

His armor is woven of cocoant fibre, and is a protection against the native weapons which are edged with swords' teeth. The mat at his back is a protection against stones thrown at the enemy by the warrior's wife, who follows in the rear. This shows a most primitive form of weaving.

THE STORY OF TEXTILES

CHAPTER I

BEGINNING OF TEXTILES

PREHISTORIC EVIDENCES OF THE ART—TEXTILE INDUSTRY AMONG
THE ANCIENTS—EARLY EXISTENCE IN NORTH AND SOUTH AMER-
ICA—THE WEST'S TEXTILE INDEBTEDNESS TO THE EAST

A bit of cloth—whether it be woollen or cotton, linen or silk—is one of the most interesting evidences of man's climb from days of savagery to twentieth-century civilization.

As one notes how finely spun and how intricately woven are the threads and how beautiful often is the design, the wonder grows that a piece of cloth can be so dexterously fashioned. And yet, as one reads of the painstaking efforts—spread over many centuries—which man has put forth to attain perfection in spinning and weaving, the wonder fades into admiration for the infinite pains he has taken to perfect the art. Civilization's pathway is strewn with the evidences of the labor to compass a mastery of the industry. Older far than recorded history is the tale of fabrics.

To find its beginning, we must go beyond the dawn of history into the darkness of prehistoric times; for, when man first began to scratch his deeds on the rocks of his dwelling-place, fabrics, more or less perfect, were being fashioned, ornamented, and dyed.

Even the archæologist cannot fully enlighten us. No matter how deeply he may delve into the most remote past

to which he can sink the plummet of his research, evidences of spinning and weaving are found among the vestiges of the rude home of prehistoric man.

PREHISTORIC EVIDENCES OF THE ART

The art was practised in the earliest Stone Age. How much farther back it was a domestic art it is impossible to learn, owing to the perishable nature of the materials from which many fabrics were fashioned. According to some authorities it may have been contemporaneous with the discovery of fire for cooking and the building of shelter. Others are sure it is older than the fashioning of domestic utensils by the art of Pottery.

It is believed that sinews and intestines of animals, strips of skin, flax, hemp, wool, the bast of the linden, and the fibre of the palm and cocoanut and other trees, and various wild grasses were used in the making of mats, baskets, nets, and rude fabrics at the dawn of the earliest era of the Stone Age, if not before,—many thousands of years before the beginning of civilization.

Evidences of the industry have also been found among prehistoric or savage races in parts of the world so widely separated that it is quite certain a knowledge of the industry sprang up independently, in different places.

It is fair to conjecture that thousands of years before the dawn of civilization some savage matron, sitting in front of the cave or rude hut which sheltered her, wove the original basket from the rushes of a brook that perchance may have gurgled at her feet, or may have cut strips of skin from the animal her lord and master had slain, and plaited them into the original fabric that was the beginning of textiles. It does not require much stretch of the imagination to conceive of this taking place in the different parts of the world where the industry began.

Flax fabrics dating back to a period thousands of years

ago have been unearthed in England. The ruins of the Lake Dwellers of the Stone Age in Switzerland have produced them. Textiles of much beauty that belong thousands of years before Christ have been discovered among the earliest ruins of Peru, Mexico, and Egypt, and in the cave dwellings of New Mexico and Arizona.

The ruins of the Swiss Lake Dwellers, which were discovered in the winter of 1853-54, abundantly prove that the art was known in the earliest era of the Stone Age,—the period of the mammoth and cave bear. The winter of 1853-54 was cold and so very dry that water in the alpine lakes of both Switzerland and Northern Italy receded so far that the dwellers on many of them saw evidences of ancient dwellings built on poles projecting from the lakes. Some sections were dyked, and many excavations commenced which unearthed village after village that had been covered by the mud of centuries. Wangen in Lake Constance, a village in Lake Mosseedorf, Robenhausen in the bog of Lake Pfaffikon, and Auvernier in Lake Neuchâtel were the most interesting.

Some of the lowest villages were many feet down, and belonged to the earliest Stone Age. In them were found crude but serviceable fabrics of bast, flax, and wool, and signs that the growth and manufacture of cloth of flax and wool at so early a date was an important industry. Spindle whorls were without number. Flax in all stages, from the unprepared straw with seed capsules in perfect preservation to excellent specimens of plaited and woven fabrics, was unearthed, and some of it was ornamented with rude human figures. Strings, yarns of flax in bales ready for the spinners, rope and cordage, were also found.

Specimens of these fabrics may be seen in many museums, and show that the Lake Dwellers of the oldest Stone Era plaited, wattled, and wove cloth, and knew all the operations, from binding and tying, basket and mat plaiting, to weaving. Basket making on a finer scale, with the flax

twisted into a thread, probably led to the textile industry which these prehistoric people practised.

So perfected had the industry become by the time the Bronze Age arrived that rude spindles and looms were employed which were very similar to those used to-day by some of the uncivilized tribes, and the art had reached a state where various designs were worked into the fabric with needle and thread.

Evidences of a similar textile industry have been found in the barrows of the early Bretons, where bodies were discovered that were wrapped in plaited woolen cloth. Similar fabrics, of an era so many thousands of years ago that archæologists cannot accurately fix the date, have been discovered in the homes of the ancient Cliff Dwellers of South-western America.

TEXTILE INDUSTRY AMONG THE ANCIENTS

At the dawn of history, wool, flax, cotton, and silk were being woven in the East with the greatest skill, and which was the first material used in weaving is not known. It is probable, however, that the possession of flocks and herds led to the spinning and weaving of wool before either cotton, flax or silk was so used; and the fact that here and there ancient records speak of fabrics of cotton and silk as if they were rare luxuries would indicate that linen and woolen fabrics were too common to receive much attention, and that those of the other materials were relatively novel.

The earliest ancient history describes Eastern nations as having already attained a high degree of skill, not only in the spinning and weaving of fabrics, but in their dyeing and ornamentation. On the walls of Nineveh, Babylon, Thebes, and the ancient cities of Peru and Mexico, throughout most of the ruins of Assyria, Persia, Egypt, and among similar ruins of both North and South America, is depicted the whole process of the textile industry, from the raising



GREEK AND ROMAN METHOD OF SPINNING AND WEAVING
(From old woodcuts)

of the sheep or growing of the flax to the spinning of the yarn and weaving of the fabrics.

The Bible in Genesis and Exodus refers to the art, Homer, Herodotus, Confucius, and Pliny, all relate traditions of how and when it originated. It is a fact established by thousands of hieroglyphics and confirmed by the oldest of Eastern historians that the Chinese, Hindus, Assyrians, Babylonians, Persians, Egyptians, and Hebrews practised spinning and weaving with great skill at a very remote period.

One Chinese tradition is that silk weaving was practised in Kiang Nan, China, in 2640 B.C. Another is that cotton originated in India, and that shawls and carpets were first woven in Persia. Fabrics of wonderful excellence were wrought by the Egyptians certainly twenty-five hundred years before Christ, and probably three thousand. At this early period the dwellers along the Nile wove linen cloth of a fineness that is still unequalled. About one Egyptian mummy was found linen cloth containing 540 warp threads to the inch, while the best woven in England up to a recent date had but 350 threads to the inch.

It is said that the Egyptians put a shuttle in the hands of their goddess Isis to signify she was the inventress of weaving. Joseph in Genesis about 1600 B.C. records that Pharaoh "arrayed him in vestures of fine linen." Another early reference to weaving is in the Bible (Leviticus xiii. 47-59) which speaks of the warp and woof of woolen and linen garments, their defilement from leprosy, and the necessity of their being burned by the priest, and shows that in 1500 B.C. the Israelites knew the art. Mummy cloths from the pyramids have borders of blue and fawn color which were made of threads colored in the yarn. Fabrics of many textures and degrees of fineness were commonly used by the Egyptians for clothing, draperies, banners, and for many ceremonial uses. Wool, flax, and cotton were all known and used by the Egyptians, as

their tombs attest; and the process of dyeing was well established.

According to Pliny, the Assyrians believed Queen Semiramis invented weaving, although he gives the honor of the invention to the Egyptians. Among the Greeks, Minerva is shown with a distaff, and is recognized as having first taught man the art. Again, the Mohammedans say that the art originated with a son of Japhet; while the Peruvians point to Mama Oollo, wife of Manco Capac, their first sovereign, as the originator. The absence of any authentic written records means unmistakably that it was prehistoric among different peoples about the same time.

Homer, the Greek poet, who lived 850 B.C., was the first historical writer to tell of weaving. He describes Penelope waiting for the return of her husband Ulysses from the Trojan War. Ulysses had endeavored to escape being called to war by feigning madness, but his trick was discovered, and he was compelled to serve away from home more than twenty years.

In the mean time the chieftains of Ithaca and the neighboring island wooed Penelope. Loving Ulysses, however, and hoping for his return, she refused to accede to the pleasure of the suitors, who remained, wasting Ulysses' means, insulting his son, and bribing the servants.

"Wait," said she, when they became impatient, "until I have woven a winding sheet for old Icarius, the father of Ulysses, so that I shall not lose my threads."

And she is described at her loom undoing each night the day's work, so that the web might never be finished. This went on for three years until her maids revealed her strategy, and she was driven to desperate straits to keep off the suitors. Ulysses finally returned in time to save her, and husband and wife were united. And thus it was that Penelope became among the Greeks and Romans the goddess of weaving.

EARLY EXISTENCE IN NORTH AND SOUTH AMERICA

The art in North and South America seems to have sprung up independently of the rest of the world, and also at a prehistoric date. The ancient Peruvians and ancient Mexicans wove cloth of wonderful fineness and with a finish not unlike lustrous silk. Many of the beautiful shades cannot be surpassed by the best skill of to-day.

Pizarro, the conqueror of Peru, found the art in 1533 had reached a perfection beyond the best artisans of Spain. The wool was furnished by the small llama and the alpaca, long domesticated, and by the vicuna and guanaco, which ran wild among the fastnesses of the Andes. A wild kind of cotton was also employed. Both sides of the fabric were woven alike, and the design and brilliant coloring of some of the specimens in the museums show a skill and art even now rarely excelled by the best artisans.

The resemblance between the Peruvian fabrics and those found in the tombs of the Egyptian kings is striking. In both cases the textile industry had reached equally high development. The Peruvian spindles were of wood, and had solid sun-burned clay whorls of beautiful finish. Yarns were twisted by wetting and rolling between the fingers and part of the body. The needles used were made from wood, bone, or copper. Among the fabrics thus woven were vests, smock-like outer garments similar to the poncho, loosely woven cloths, loin girdles, head coverings, and sandals, home drapings for walls, doors, awnings, banners, and blankets. The ceremonial fabrics were of high color.

These fabrics of the Incas are at least one thousand years old. Color and design are of a high order, and are as beautiful to-day as when woven, showing that even the use of dyes had been highly developed. Geometric, conventionalized animal and human figures are shown on mummy cloths. Both cotton and wool were used, and

the material was woven upon simple hand looms from yarn spun in the crudest way.

Some of the American Indians wove fabrics of a high order. Blankets made by the Navajos of Arizona and New Mexico are of so close a texture they will hold water, and in design and brilliancy of color are most striking, although woven in a primitive manner, by hand.

The beautiful white "Tappa" cloth of the South Sea Islands was made in a peculiar way, especially by the natives of the Marquesas Islands. Instead of being woven, it was beaten together. The exterior green bark was stripped from the branches of the so-called "cloth" tree, a species of the mulberry, which grows luxuriantly in those regions, and the remaining fibrous substance was then removed from the stick to which it had adhered. A quantity of this fabric wrapped in large leaves, and secured by fibrous cords to prevent its being swept away, was placed in the bed of a running stream. After two or three days' immersion the bundles were opened and the fibres pulled out and exposed to the air. Each piece was inspected to ascertain whether it was ready for the remaining operations. If not, it went back to the bed of the brook until the conditions were such as were desired.

When evidences of decomposition were shown by the fibres becoming soft and flexible, the natives knew that the material was in the proper condition for the next step of the operation. The different strips were then laid in layers upon a smooth surface, such as the prostrate trunk of a cocoanut-tree, and were beaten with a kind of heavy mallet, made of ebony, in shape somewhat like an old-fashioned razor-strop. Upon the surface of the hammer were shallow parallel indentations, which varied in depth on different sides, so that it was adapted to the several stages of the operation. The hammering thus produced the corduroy stripes that were prominent in the "Tappa."

The fibres of the "Tappa" were thus beaten, and layer



NAVAJO WOMAN MAKING YARN OF THE NATIVE WOOL

(From a photograph by George R. King)

after layer was put on until the whole was merged into one mass. The beating then continued, water from time to time being added, until the material reached the required thinness, according to the purpose for which it was to be used. It was then placed on the grass to bleach, and came out a dazzling whiteness; or it was impregnated with vegetable dyes, which gave it a permanent color. Brown and yellow were generally the common tints.

According to Captain Sylvanus Nickerson, who commanded the clipper ship "Huguenot" when she was lost in 1880 off the island of Java, the Malays of some of the islands of the Ombay Straits still weave their garments of cotton which is grown in the same row with the corn, with little or no cultivation, and without any effort to separate the plants. They take the cotton as it comes from the boll, and, making it into a ball, twist the fibre with the fingers, pulling it from the ball. As fast as the cotton is twisted into the required thread, the crude thread thus formed is wrapped on a piece of bamboo about five or six inches long. When a sufficient quantity has been prepared, it is put on the loom for weaving. The loom consists of two upright posts, or sticks, driven into the ground at the distance required to give the fabric a certain width. The warp is wrapped about these sticks, and the weft thread is worked in and out with a crude needle and pounded into position.

The method of weaving practised to-day by the Navajos is the same as that employed by the hand weavers of India and China, and is virtually identical with the method that has been used from the beginning by primitive weavers the world over. The warp is stretched between two parallel poles suspended between upright posts, and the weft threads are drawn in and out of the warp with a rude wooden needle somewhat like a fisherman's needle and beaten together with a stick. Seated upon the ground, and with no pattern save that in the mind's eye, geometric

designs and quaint figures are worked in the fabric with threads of beautiful colors.

Basket weaving of hemp and the soft bast of linden was quite generally known by the savages at Wellfleet. Among the Algonquin Indians feathers of the wild turkey and other birds, and white hair of the moose were beautifully woven into hempen garments and articles of utility. In 1785 Eli Twichel, of Bethel, Me., received from Millocket, an old Indian woman of Oxford, a twofold pocket-book which she had woven of hemp and beautifully embroidered with long white hair of the moose. It shows admirably the high state of art reached by the Algonquins, and is now in the Maine Historical Society.

THE WEST'S TEXTILE INDEBTEDNESS TO THE EAST

As civilization spread from the East to the West, so Asia and Egypt passed on to Greece, Italy, Spain, and the rest of Europe the knowledge in its higher form of spinning and weaving. Italy and Greece first used the information thus obtained, and then taught Spain, France, and Flanders the art of weaving woolen and cotton goods.

At a late date in ancient history Germany had obtained the art, and its people were secretly practising it in caves and vaults, as if they were either afraid of it becoming known or, being a warlike people, were too proud to have it said that they labored at the loom. England and North-eastern Europe received the knowledge from Germany.

By the tenth century the manufacture of woollens had attained such perfection in Flanders that one author said, "The art of weaving seems to be a gift bestowed upon them by nature," and another, that "all the world was clothed from English wool wrought in Flanders." Count Baldwin III. of Flanders had established the first weavers and fullers at Ghent shortly before 961, and also instituted yearly fairs at Ypres, Bruges, and other places.

The invasion of England by William the Conqueror, in 1066, found the Angles and Saxons already spinning and weaving the wool of their flocks, and considerable skill had been attained, though it had not reached the high level of the Continental work, particularly as practised by the people of France and Flanders. As the invasion brought in its train a large immigration to England of the Flemings, who settled in the western part of England along the Irish Channel and in what is now Lancaster, their skill raised English spinning and weaving to a level little below that of the Continent, and made their part of England a great seat of the industry. It received further impetus during the reign of Henry I. from further immigration of workmen from Flanders. And still more Flemish weavers, because of their great skill in weaving and spinning, were induced by Queen Elizabeth to settle in England; and so was the foundation laid in England of what has become the greatest textile manufacturing centre in the world. And now let us glance at the history of the raw and manufactured products of flax, wool, cotton, and silk.

CHAPTER II

FLAX, LINEN, WOOL, COTTON, AND SILK

FLAX AND LINEN—HISTORY OF LINEN—PRODUCTION OF FLAX AND LINEN—WOOL—EFFORTS TO IMPROVE WOOL—EARLY USE OF WOOL—COTTON, THE PLANT, GROWTH, AND DISTRIBUTION—EARLY HISTORY—COLUMBUS AND COTTON—SILK—EARLY HISTORY OF SILK—SILK INDUSTRY IN AMERICA

Flax, the term used to denote the plant and the fibre, divides with wool the distinction of being the material first used in spinning and weaving. The plant belongs to the botanical order termed *Linaceæ*, and is known scientifically as *Linum usitatissimum*. It is an annual with stalk rising two to three feet and more in height, has narrow lance-shaped leaves and branches at the top with a bright blue flower on each branch.

Flax has been cultivated for thousands of years in Mesopotamia, Assyria, and Egypt, and is wild in the region between the Persian Gulf, the Caspian and Black Seas.

The stalk is a woody cylinder, more or less pithy and hollow when dry, and is enclosed in bark consisting of long, strong, silky fibres, cemented together by a kind of glue and encased in an outer bark or skin which adheres as if glued to the fibre. The fibre, when freed from all else so far as possible by the process of rotting, to destroy the glue, breaking to free it from the woody part of the stalk, scrutching to whip out the small particles of bark and stalk that adhere, hatchelling to straighten it and free it from tangles, is nearly pure bast of a light gray and brown color, inclining to green. It is exceedingly tough, adapted to spinning and weaving, capable of being bleached to snowy whiteness,

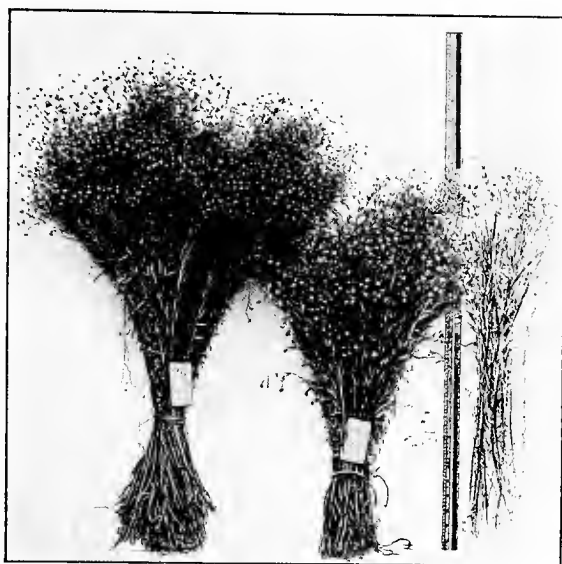

SPECIMENS OF NORTH DAKOTA GROWN RUSSIAN SEED-FLAX



CUTTING HEMP

(From illustrations furnished by the United States Department of Agriculture)

and will take more readily than cotton a variety of colors by dyeing.

The ultimate filaments vary from one six hundred and fiftieth to one five thousandth of an inch, are hollow, thick-walled, and nearly solid cylindrical cells, terminated by exceedingly attenuated points. They are semi-transparent, of a silky lustre, and under the microscope the walls of the tube appear like a double line through the centre. The cells are jointed like stalks of bamboo. When the fibre is separated, it is either dressed flax or tow. The seeds, small and glossy green, are called linseed, and furnish the linseed oil of commerce. As the gum joining the mature flax fibres is insoluble by methods that are profitable, the thread for linen cloth is made from the green flax. If the seed is allowed to mature as a source of oil, the flax straw is useless for linen; for all attempts to utilize flax straw have as yet been without commercial success, though the ripened flax straw has been known to withstand without decay the weather for about a century, showing its great lasting qualities.

In the preparation of flax for spinning, it is soaked in water or exposed to the dew until the woody part rots or rets away from the basty interior, which is then separated from the woody enclosure. The heckle, a many-toothed steel comb, then removes the coarser tow and separates the filaments of the flax. Upon the number of hecklings, so called, depends the fineness of the flax, for the fibres are united into a roving which is spun into a continuous thread.

HISTORY OF LINEN

Linen, the general term for the material spun from flax or hemp, antedates existing records belonging to the earliest eras of the prehistoric ages of which traces have been discovered, and has been found in the villages of the Lake

Dwellers and in other parts of the world where ruins have disclosed the remnants of fabrics.

The Finns introduced flax into North Europe, the West Aryans brought it to West Europe, while the East Aryans conveyed it to Hindustan. In ancient Europe the priest, only, wore linen habitually. Frequent references to it may be found in the Bible to show the esteem in which it was held. It is said in Genesis that hail destroyed the flax and barley. Herodotus refers to it as an article of Egyptian export. The wrapping of most of the mummies, some of which are three thousand to four thousand years old, is of linen. In Homer the mother of Nausicaa is depicted as spinning purple fabrics at early dawn by the hearth.

The garments of the Hebrew, Egyptian, Greek, and Roman priests were often made of fine linen. Bengal cultivated the flax, and the Hindustanee spun and wove it into linen at an early date in ancient history, as did also the ancient Thracians. In mediæval times Italy and Spain and France were celebrated for their linen fabrics. Charlemagne in the eighth century A.D., like many a modern, wore linen underwear. The Moors of Spain brought the industry to a state of high perfection and exported their fine linen to Constantinople and India.

Flanders, Brabant, some of the German towns, and France were making linen fabrics by the eleventh century, and before 1250 Flanders had begun extensive exportation to England. Ypres, which as early as 960 was one of the seats of the industry, has given us the word "diaper," or cloth of Ypres, which then denoted a great fineness of manufacture. The King of France in 1394 sent the fine linen of Rheims as a ransom to the Sultan for some noblemen who had fallen into his subjects' hands. The famous Bayeux tapestry is of linen body with the designs in wool.

Among the Anglo-Saxons linen and wool were both spun

and woven, and history mentions the skill of the daughters of Edward the Elder. Fine linen was made in Sussex and Wiltshire as early as 1253. A guild of linen weavers was organized in 1386 at London. The linen industry, however, did not flourish in England as it did on the Continent, so that in 1677 it was proposed to establish spinning schools as they then existed in Germany. As many as two hundred girls from six years upwards sat under the supervision of a woman who in a pulpit directed the pupils, and tapped with a long white wand any child who neglected her work. When this did not suffice, she rang a bell, and the offender was taken away and whipped.

Irish linen weaving began in the eleventh century, but it received its great impetus from Louis Crommelin, who had been driven from France by the revocation of the Edict of Nantes in 1685, which instituted religious persecution. From this period also begins England's supremacy in the textile industry, for the religious intolerance that the edict entailed drove three hundred thousand of the best French artisans from their native country. It was not until 1725 that machinery was used in Irish weaving, and not until 1828 that flax was spun by machinery.

Linen had begun to be woven in Scotland in the reign of Charles I., and by 1688 had become an important Scottish industry, which had already raised the apprehensions of the English weavers; for the Scotch packmen who went into England in 1684 to sell goods were sometimes whipped as malefactors and required to give bonds that they would abandon the trade.

Linen was also one of the Puritan domestic industries, and as linsey-woolsey gave its name jointly to a fabric composed both of flax and wool. Linen has never been successfully woven in America except in the coarser forms of crash and towelling. Scotland, Ireland, and Belgium produce the finest linen; Russia, the largest amount of flax; and Coutrai, Belgium, the flax best prepared for

spinning. Most of the American-grown flax is raised for seed only.

PRODUCTION OF FLAX AND LINEN

America has never been able to equal the Continent in its production of the finest linen, none of the growers of flax giving the attention to the proper preparation of the fibre which has made that of the Belgian, Irish, and French growers so superior. Most of the Western farmers grow their flax for the seed. The tedious process of the separation of the fibre from the stalk and its preparation for the yarn require the cheapest form of labor to make it profitable, and for this reason more than any other America has not yet raised the flax fibre in quantities that would be commercially successful.

The total production of flax for the year 1909, or the last year given by the census of the flax-producing countries, was 1,872,127,000 pounds, of which Russia produced 1,594,000,000; Austria - Hungary, 104,332,000; France, 46,340,000; Italy, 44,800,000; United Kingdom, 26,934,000; and the United States but 4,000,000 pounds. The number of establishments producing flax, hemp, and jute products in America in 1909 was 149, the value of the product was \$58,946,000, the capital invested was \$73,393,000, and the number of employees was 26,361.

Russia, Austria, Germany, France, Belgium, Holland, England, Scotland, and Ireland are great producers of linen to-day. The best yarn probably comes from Holland, Belgium, France, and Ireland. The United States occupies a relatively low standard as to the amount of products turned out.

WOOL

The date at which prehistoric man discarded the pelt of skins for the woven fabric of wool or linen marks the origin of the textile industry. Wool was probably the

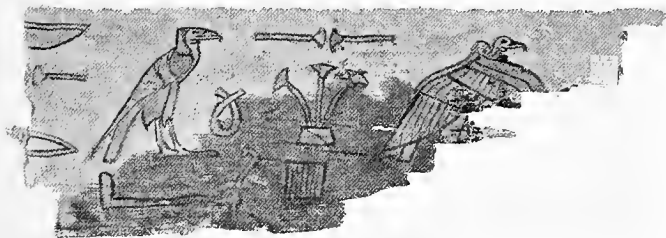
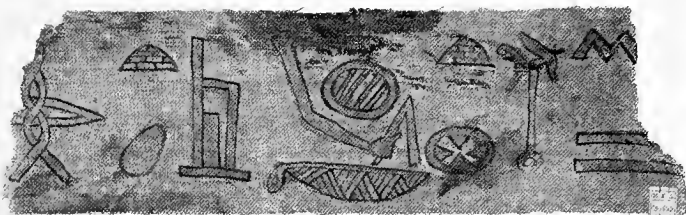
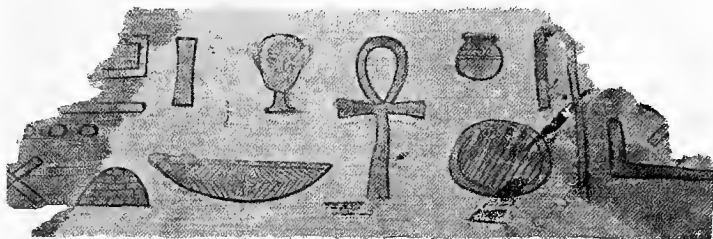

LINEN MUMMY CLOTHS

(From an Exhibit in the Boston Museum of Fine Arts)

Specimens from Egypt, date about 1545-1350 B.C. The hieroglyphics are painted yellow and outlined with black.

first material spun by early man; for flocks and herds and a pastoral existence was the first upward step in civilization from the primitive conditions of savagery. Primitive sheep were covered with hair, and the wool which now characterizes them was a downy undercoat. As time progressed and the art of spinning and weaving developed, the food value of sheep decreased as their wool value increased, and the hairy flocks were bred out and sheep with true wool succeeded. Even now the growing of hair among the wool of old or neglected sheep is an atavistic return to the original condition.

Although the best quality and greatest quantity of wool comes from sheep, it is also found on many fur-bearing animals, such as the angora goat, cashmere goat, camel, alpaca, and the llama. No less than six or eight qualities of wool come from a sheep, each kind having its particular advantage for manufacturing. As a rule, hair is the longer and the exterior fibre, while wool is the short fibre next to the skin. Wool is pliable and warm and has the property of felting.

EFFORTS TO IMPROVE WOOL

When and where efforts were first made to improve the wool production of sheep is not known, but evidences exist to show that the Romans about 200 B.C. had begun the attempt which resulted in a breed of Tarentine sheep with a long, heavy, and fine staple wool. In "De Re Rustica" of Columella, written about the middle of the first century, he states that his uncle Marcus Columella, a farmer of Spain, succeeded in greatly invigorating his delicate Tarentine ewes by crossing them with African rams. The Tarentine fleece had been either brown or black, but by this outside breeding Columella succeeded in procuring not only much more vigorous stock, but a heavy, white, fine wool.

The cross-breed thus accomplished was the original of

the Spanish merino, and with modifications and crossings has been the parent stock of the fine-wool sheep of Europe and America. Pedro IV. of Castile in the fourteenth century and Cardinal Ximenez in the sixteenth century renewed the stock with Barbary rams. The Spanish stock was imported by Louis XIV. of France with great difficulty, owing to Spain's refusal to allow sheep to be imported and improved, resulting in the French merino, one of the best long-wool breeds. Importation of the same Spanish breed to Germany, cross-breeding, and climatic changes have produced the fine Saxon wools, so advantageous for the best broadcloths. To this merino origin may be traced the French sheep of Naz, which produce wool of such silky lustre.

The first mention of sheep in England is in a document of 712, where the price of the animal is said to have been placed at one shilling "until a fortnight after Easter." By the beginning of the thirteenth century England was the great wool-producing country of Europe, and was furnishing the weavers of Flanders their wool to such an extent that it was considered good policy for Flanders to keep peace with England.

Sheep were first introduced into America at Jamestown in 1609, and the colonial government in all the colonies encouraged the raising of sheep. President Washington imported the best breeds of sheep from England, and promoted the bringing to this country of the most experienced spinners and weavers from England.

The merino strain was introduced into America between 1801-12 by William Jarvis, Colonel David Humphreys, and others, and with the various merino strains make up the flocks prized for their wool. Colonel Humphreys, while United States minister to Spain, had conceived the idea of introducing merino sheep into America, and April 10, 1802, shipped from Lisbon one hundred sheep, nine of which died on the way. The remainder were sold to the farmers about

Derby, Conn., for a hundred dollars per head and greatly improved the strain of American sheep.

The Australian and Cape Colony sheep which produce the best wool have the merino strain. Where the food-producing qualities have been considered as well as the wool, the wool is apt to be medium or coarse in quality. This is true of the South-western and Pacific States flocks, and the South American breeds. The best English strains are the Leicester, Border Leicester, Lincoln, Cotswold, Kent, Devon, Longwool, South Devon, Hampshire, Wensleydale, Roscommon and Oxford Down.

Henry Dudding, of Riby Grove, Lincolnshire, England, in 1906 sold a Lincoln ram raised by him for about seven thousand dollars. The same year Robert and William Wright, of Hocton Heath, Lincoln, sold their flock of 950 Lincolns to Señor Manuel Cobo, of Buenos Ayres, for about one hundred and fifty thousand dollars.

Wool is divided into pulled and clipped or fleece wools. The two latter are cut from the living sheep, while the first is pulled by the roots from the pelt of the dead sheep. The clipped wools make up the greater part of the market and are divided into long and short staple, or combing and clothing wools.

Clothing wools are used for broadcloths and heavy cloths, the finer combing wools for the thinner fabrics for women's wear. Medium wool is used for worsted goods, alpacas, mohairs, and the like, while the coarser goes into carpets, blankets, and similar goods.

The production of wool in the principal sheep-raising countries in 1909, as given by the Report of the Tariff Board, was 2,490,600,000 pounds, divided as follows: Australia, 718,000,000; Continental Europe, 420,000,000; Argentina, 401,200,000; United States, 328,100,000; New Zealand, 223,000,000; United Kingdom, 142,000,000; Uruguay, 127,400,000; and British South Africa, 130,900,000.

The number of sheep raised in America in 1910 was

51,809,068, and in the United Kingdom, 31,164,587; in Argentina in 1908, 67,211,754; in Australia in 1909, 91,676,281; in New Zealand in 1911, 23,996,126; South Africa in 1910, 31,102,467; Uruguay in 1910, 26,286,296; Russia, 82,672,123; Ottoman Empire, 41,000,000; British India, 21,824,000; China, 18,900,000; France, 17,357,640; Spain, 15,471,183; Austria-Hungary, 13,991,500; Italy, 11,160,000; Canada, 2,598,470.

The value of manufactures of wool in America in 1909 was \$507,219,000; the capital invested was \$506,323,000, ranking next to cotton; the number of establishments was 1,126; and the number of employees, 208,739.

EARLY USE OF WOOL

The spinning and weaving of wool has been practised, as we have seen, from a most remote antiquity, and in the Far Western America as well as in remote Eastern Japan and China. Remnants of wool as well as linen are found in the barrows of the Britons and also in other tombs. The art is frequently referred to by ancient writers, and, when we enter the mediæval age, we find more frequent references to it in the many statutes that were passed regarding it and its regulation.

Sheep were domestic among the Britons long before the advent of the Romans, and some use was made of sheepskin and wool. But the Romans certainly taught the Britons more perfect weaving and spinning. The Romans established a wool factory which supplied their army, and the Britons were quick to learn. It was not long before the product of Winchester looms had a reputation abroad, and it was said, "The wool of Britain is often spun so fine that it is in a manner comparable to the spider's webs." The fibre was in great demand in the Low Countries.

The Angles and the Saxons brought with them to England a knowledge of rude spinning and weaving, and Alfred's

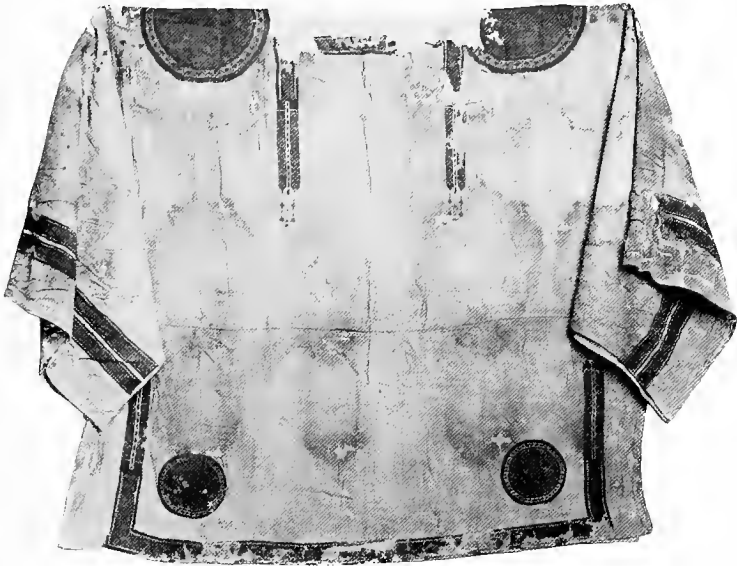

EGYPTIAN TUNIC

(From an Exhibit in the Boston Museum of Fine Arts)

A tunic from a Coptic grave in Egypt dating from the first to the seventh century A.D. Into the garment of plain basket weave are woven with reddish-violet wool and white linen threads circular medallions and bands of ornaments. The garment was made in one piece and sewed together under the arms.

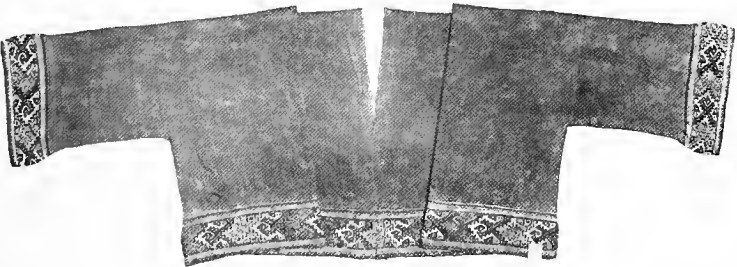

PERUVIAN TUNIC

(From an Exhibit in the Boston Museum of Fine Arts)

Woven with cotton, decorated with borders of tapestry weaving of colored wools. The red wools are dyed, while the yellow and brown are the natural color of the Vicuna and the alpaca wools. It shows the high skill reached by the Peruvians in the textile industry before the Spanish Conquest.

mother is referred to as skilful in spinning. Although early English history is full of allusions to the textile industry, the English products could not compare with those of the Continent. At various times, beginning with the reign of William the Conqueror, who allowed Flemish weavers to settle at Carlisle under the protection of the queen, there were immigrations of skilled Flemish workmen caused by the Continental wars and persecutions, and little by little these immigrants established the higher industry here and there in England.

Henry II., who reigned from 1154 to 1189, inaugurated the cloth fair in the churchyard of the priory of St. Bartholomew, established guilds of weavers, and granted the city of London the exclusive rights to export woolen cloth. An act passed in 1189 prohibited the mixing of Spanish and English wool, and another in 1197 regulated the dyeing of wool to be sold. Edward I. "settles his sons to schole and his daughters he set to woll-worke," and in 1279 a petition asserts that the wool exported to Flanders was nearly half the land in value.

Edward III. gave special attention to wool industries, bringing weavers, dyers, and fullers from Flanders, and prohibited, under pain of life and limb, the exportation of wool. English wool had been in great demand in Flanders, Brabant, and France, and was second only to Spanish wool. The practice of creating large sheep farms, with the consequent number of people thrown out of employment and the increased price of agricultural products, led in 1489 to legislation restricting sheep raising. This shows that England's woolen industry at this early date was an important one, for she was then beginning to export her woolen fabrics.

The statute books of Edward III. and IV. and the subsequent rulers of England contain frequent references to wool and its manufacture. Efforts to prevent the exportation led to much smuggling, and it was not until the reign of Queen Elizabeth that the free exportation of wool was

permitted. In 1660 acts prohibiting the export of wool were passed again, and those remained in force until 1825.

The impetus which the English textile industry received from the immigration of weavers, particularly from France, was undoubtedly great, and much of the skilful knowledge of Lancaster and Manchester and Bradford and the other towns in the great textile centre may be traced to the French weavers whom France's disastrous intolerance drove from home.

Wool was the principal staple used in the English industry until the middle of the eighteenth century, when the inventive genius of Kay, Hargreaves, Arkwright, Cartwright, and Crompton gave such an impetus to weaving, particularly of cotton, that it was not long before cotton had wrested from wool its long supremacy.

COTTON, THE PLANT, GROWTH, AND DISTRIBUTION

"Cotton supplies nine-tenths of the material employed in the manufacture of clothing," said M. Jean de Hemptinne, of Brussels, in opening the International Congress of Cotton Manufacturers in Brussels in June, 1910. It is the most valuable of all plants, and grows generally in tropical and sub-tropical regions. The commercial crop for 1910, estimated in five hundred bales, was 18,321,000 pounds, of which two-thirds were grown in the United States. The name is derived from the Arab term *qutun*, and in its transmission through other languages changed into the English name, "cotton."

Botanically, it belongs to the genus *Gossypium*, of the Malvaceæ, or Mallow, order, and, excepting the caravonica-tree, is a small, bush-like plant with broad, three-cleft leaves and with seeds that grow in capsules, or bolls, surrounded by a soft white or cream downy fibre which can be readily spun. These fibres are unicellular hairs which are attached to the seed, and each hair is the outgrowth of a

single epidermal cell of the outer coat of the seed. Under the microscope these hairs, or fibres, are round when green, but, when dried, are flattened and twisted, not unlike an empty twisted fire-hose. This characteristic differentiates true cotton from the false flosses which have no twist, and also aids greatly in the spinning of the fibre.

The best cotton has a long fibre and is known as "Sea Island cotton," because it is grown on the islands off the coast of South Carolina, Georgia, and Florida, while the shorter fibre cotton is grown on the mainland and is called upland cotton. Egyptian cotton ranks next to Sea Island cotton in value. Sea Island cotton originated in the Lesser Antilles.

The seed is sown in April, and the fruit, or bolls, covered with the fibre, are gathered in September and October. Not alone is the cotton of value, but the seed now furnishes the valuable cotton-seed oil and a meal which, as a food for cattle, has great fat-producing qualities and is also rich in fertilizer, while the fibre of the inner bark is almost as valuable as jute. The cotton-producing countries of the world in the order of the value of their output are as follows: Southern United States, British India, Egypt, Russia, and Brazil.

EARLY HISTORY

History cannot tell us at what date cotton was first spun and woven into fabric; for cotton, like wool, was being made into clothing when history began. In different parts of the tropical world vegetable growths akin to cotton were in use in prehistoric times, and at the dawn of history cotton's manufacture into fabrics was already well established in the Orient, particularly in India and in China.

Cotton has been for thousands of years the staple fabric of the East, and where warmth was required it was padded by the Chinese into thick garments. It was probably exported from India to Palestine and Egypt, where it

became indigenous, and gave rise to flourishing ancient textile industries, along with flax and wool.

An early mention of cotton is in the Bible in King Solomon's time, 1015 B.C. to 975 B.C. Herodotus, the father of history, in 445 B.C. makes the first historical mention of cotton. In speaking of the people of India, he says, "They possess likewise a kind of plant, which instead of fruit produces wool of a firmer and better quality than that of sheep: of this the Indians make their clothes."

Cotton was brought from India by Alexander in 500 B.C., and from then until about the birth of Christ it was in use on the shores of the Mediterranean. Cæsar and the Roman army wore clothing made of it, as did the Roman people. It was imported from India by the Romans, though it was an article of common manufacture in Upper Egypt, where garments were made for the Egyptian priesthood. It was also spun and woven on the Island of Tylos in the Persian Gulf and in many other parts of the Eastern world.

Pliny, the Roman naturalist (A.D. 23-79), says that Egyptian priests, as well as the common people, wore cotton "woven into beautiful garments from down wool spun into thread, the wool of which was cotton growing in upper Egypt toward Arabia." The same authority asserts that the origin of the manufacturing of cotton cloth was in the weaving establishments founded by Semiramis on the bank of the Tigris and Euphrates.

Arab traders were the first to import it in any quantity to Italy and Spain. Arrian, an Egyptian Greek of the second century A.D., in his "Circumnavigation of the Erythraean Sea," is the first writer to mention it as an article of commerce. At as early a date as the first century the Arab traders were bringing Indian calicoes, muslins, and other cottons to ports on the Red Sea and thence to Europe. It was said of Omar, one of the caliphs of Mahomet, that "he preached in a tattered cotton gown, torn in twelve places."



THE COTTON PLANT

*(From F. H. Bowman's "The Structure of the Cotton Fibre," courtesy
of The Macmillan Company)*

The leaves, the bud, the flower, and the boll of cotton, showing the cotton
ripe in the boll ready for picking.

The first cultivation of cotton in Europe was probably by the Moors in Spain, in the ninth century in Valencia; and it continued to be raised and spun in different parts of Spain during the tenth century, and until the Moors were expelled. Fustians and dimities were first wrought in Spain, and from Spain the industry spread to Venice and to Milan in the fourteenth century.

In the latter part of the thirteenth century Marco Polo speaks of cotton as vegetable wool growing on trees, and early engravings represent the trees with sheep's heads at the ends of the branches. He also states that cotton was manufactured in all parts of India and some parts of China, and was woven, even at this early date, of colored threads. By the fourteenth century the industry had begun in Venice and Milan, where the warp, though sometimes of cotton, was usually of linen.

Cotton was evidently known and used in England at a very early date, and was probably imported from the Spanish Arabs. In the Wardrobe Act of 1212, twelve pence is mentioned as the price of a pound of cotton for stuffing the acton of King John, and shortly after cotton wool is described as being used for candlewicks. By 1430 it was being imported into England in large quantities, and the Netherlands had also a large trade in cotton with Italy and the Levant, and from this time on frequent mention is made of it in England.

Owing to the confusion of fustians of wool with fustians of cotton in the early mention of the cotton industry in England, it is impossible to fix the exact date at which the manufacture of cotton began there. The earliest reference which has been found that fixes a date is in the will of James Billston, who is described as a cotton manufacturer, and whose will was probated at Chester, 1578.

Another early reference to cotton is in a petition to the Earl of Salisbury, made presumably 1610, asking for a continuance of the grant for reforming frauds committed

in the manufacture of "bombazine cotton such as groweth in the land of Persia, being no kind of wool."

A petition of merchants and citizens of London engaged in buying and selling fustians made in England, dated probably 1621, shows that "divers people in this kingdom, chiefly county of Lancaster, for twenty years past were making fustians of a kind of bombast or down, being a fruit of the earth growing upon little shrubs or bushes, brought into this kingdom by Turkey merchants from Smyrna, Cyprus, Acra and Sydon, but commonly called cotton wool, and also of linen yarn, most part brought out of Scotland, and other some made in England, and no part of the same fustian of any wool at all, for which said bombast and yarn imported, his Majesty has a great yearly sum of money for the custom and subsidy thereof."

It says further that "40,000 pieces of fustian were made in England, the subsidy coming to eight and ten pence per piece, and thousands of poor people worked on these fustians."

In 1503 sixpence a yard was paid for russet cotton for the "Queen's Choare," and in the household books of Lord William Howard in 1612-40 both cotton and wool are mentioned. Lewis Roberts, captain and merchant of London, speaks in his "Treasures of Traffic" in 1641 of the Turkey Company bringing cotton and cotton yarn from Cyprus and Smyrna.

In this ancient record of trade Manchester is thus early depicted as the centre of a flourishing textile industry, and it is spoken of as buying yarn of the Irish, weaving it, and returning it to Ireland to sell. England had then already begun its export trade, buying cotton from India, Cyprus, and Smyrna, and making it into fustians, vermilion, dimities, and other stuff, and sending the surplus product abroad.

The East India Company had begun the importation of calico from Calicut, India, in 1631; and for a long time

it was judged to be a soft linen. In 1663 the question was raised what revenue tax it should bear, and Pepys's Diary, Feb. 27, 1663, refers to the question as follows:—

“Sir Martin Noell told us the dispute between him as a farmer of the additional duty and the East India Company, whether callico be linnen or no: which he says it is, having been ever esteemed so; they say it is made of cotton woole and grows upon trees, not like flax or hemp. But it was carried against the company though they stand out against the verdict.”

The result is not known, but the importation was small. The section of England about Manchester was thus early the seat of a growing textile industry, which was later to dominate the entire textile world; and the industry sprang up here through the settlement at an early date of the Flemish spinners and weavers from Flanders, who quickly followed in the train of William the Conqueror. Then again the religious persecutions in Europe during the Middle Age, particularly the revocation of the Edict of Nantes in France in 1685, as we have seen, drove many thousand skilful Huguenot weavers to England, thus strengthening the English industry at dear cost to industrial France.

Of so little importance was cotton in England that prior to the nineteenth century it was an insignificant article of commerce, and in 1736 it was regarded chiefly as an ornamental plant. At the accession of George III. in 1760 the whole importation did not amount to more than 200,000 pounds, and in 1782 it did not exceed 2,000,000.

COLUMBUS AND COTTON

The first mention of cotton in America occurs in the journal of Christopher Columbus, who, under date of Oct. 12, 1492, describes the natives of Watling Island, where he first landed, bringing, among other things, skeins of cotton thread out to his ship.

“Afterwards when we were in the ship’s boats,” he continues under the same date, “they came swimming toward us, and brought us parrots and balls of cotton thread and spears, and many other things which they exchanged with us for other things which we gave them, such as strings of beads and little bells.”

Under date of Oct. 13, 1492, he says the natives were ready to trade for everything down to bits of broken crockery and glass. “I saw one give sixteen skeins of cotton for three of ceotis of Portugal, equal to one blanca of Spain, the skeins being as much as an arroba of cotton thread. I shall keep it and shall allow no one to take it, preserving it all for your Royal Highnesses, for it may be obtained in abundance. It is grown on this island, though the short time did not admit of my ascertaining this for a certainty.”

He subsequently found trees of cotton of sufficient fine quality to be woven into good cloth. He also saw handkerchiefs of fine cloth very symmetrically woven and worked in colors. Under date of October 16, he speaks of seeing, on the Island of Fernandina, cotton cloth made into mantles. Speaking again under date of October 16 of cotton, Columbus says of the natives, “Their beds and bags for holding things are like nets made of cotton.” Here Columbus says they “saw married women wearing breeches made of cotton, but the girls do not, except some who have reached eighteen.”

This is especially interesting because it shows that very early the American natives, particularly those of the South, not only raised cotton, but wove it into fabrics and garments of various kinds. Balls of native cotton spun on distaffs by natives of Guiana, South America, and similar to those spoken of by Columbus, are to be seen in the museum at Georgetown, Demerara.

Magellan found the natives of Brazil using cotton lint for making beds in 1519 when he circumnavigated the globe. Emperor Charles V. received from Hernando

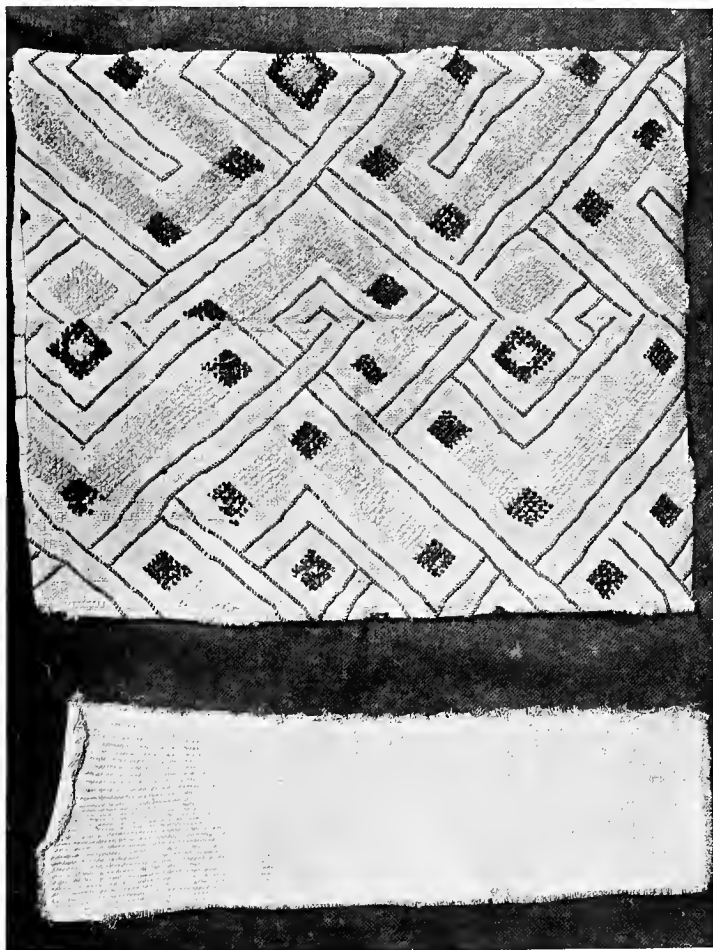

FABRICS WOVEN BY THE BAKUBA TRIBE, AFRICA

(From the Boston Museum of Fine Arts)

Specimens of fabrics woven by the Bakuba tribe of the Congo River section. Both show no evidence of contact with civilization. The pink grass cloth is of a plain weave. The black and white design, also of grass, has a pile like velvet.

The plain piece is made from grass cloth, especially for chiefs.

Cortez cotton goods of different kinds from Mexico at the time of Cortez's conquest. They comprised cotton mantles, white, black and white, red, green, yellow, and blue; waistcoats, handkerchiefs, counterpanes, tapestries, and carpets of cotton, some of the colors of which were extremely fine. In fact, cotton was in use among the Algonquins, for Champlain says that the Indians whom he encountered at Lake Champlain July 2, 1609, wore arrow-proof doublets made of strips of wood bound together with cotton.

So far as is known, the first mention of cotton growing in the United States proper is by De Vica, who found it in 1536 in what is now the States of Louisiana and Texas. The English colonists sowed the first cotton-seed in Virginia in 1607. In 1620 a pamphlet, called the "Declaration of the State of Virginia," stated that cotton wool was to be had there in abundance, and in 1621 cotton is quoted at eightpence a pound. Many travellers mention the cultivation of cotton in America during the seventeenth century and early half of the eighteenth century. It is mentioned in Virginia in 1649, in South Carolina in 1664, 1682, 1702, 1731, and 1741, and in Georgia in 1735, 1738, and 1749.

It was regarded, however, as a garden plant rather than for domestic use in most localities except parts of South Carolina and Georgia, and it was not until after the Revolution that its cultivation began, as we shall see later, on a large, systematic scale in the South. There were two causes which militated against Southern cotton growing during this country's connection with England. The first was the discouragement by England of the establishment of any industry in this country that would compete with the English cotton industry; and, secondly, there were no means of cleaning the American cotton from the seed even after it was grown, so that it was only when the Revolution cut off trade with England that the Southern cotton growers, stimulated by the home demands, set about growing

cotton systematically. The story is told in a subsequent chapter.

The first manufactory of cotton in America, as well as the first establishment of the textile industry in America, by the whites occurred at Rowley in 1643, and is described by Edward Johnson in his book "Wonder-working Providence of Sion's Saviour in New England," published at London in 1654.

It may be interesting to glance at these statistics relating to the cotton industry.

The world supply of cotton for 1909 was 8,505,191,000 pounds, of which the United States produced 5,157,691,000, or 60.6 per cent.; British India, 1,801,000,000; Egypt, 455,500,000; Russia, 360,000,000; China, 300,000,000; Brazil, 180,000,000; and Turkey, 16,000,000.

The value of the United States crop the same year was \$700,000,000. Two-thirds of the crop of this country is sent to foreign countries. No less than 9,000,000 persons are employed in its production, handling, and manufacture. 6,000,000 of those thus engaged are farmers and farm laborers, 1,000,000 are otherwise engaged to some extent in the United States, and at least 2,000,000 are employed in other countries in its transportation and in the manufacture of which it is the basis. The capital engaged in the United States manufacturing industry in 1909 was \$821,109,000, and the value of the output was \$629,699,000. There were 1,322 establishments engaged in the manufacture, employing 387,252 persons.

The number of cotton spindles and mill consumption of the world for 1910 were as follows: United States, 29,189,000 spindles, using 4,799,000 bales; United Kingdom, 53,397,000 spindles, using 3,372,000 bales; India, 5,657,000 spindles, using 1,653,000 bales; Germany, 10,200,000 spindles, using 1,660,000 bales; Russia, 8,250,000 spindles, using 1,457,000 bales; France, 7,100,000 spindles, using 951,000 bales; Japan, 2,005,000 spindles, using 1,028,000 bales; China, 765,000 spindles, using 315,000 bales; Brazil, 1,000,000

spindles, using 370,000 bales; and, including countries of minor importance, a total is reached of 134,526,000 spindles, using 18,321,000 bales of 500 pounds each.

Of the number of cotton spindles in the United States in 1910 Massachusetts had 9,853,610, or 34 per cent. of the whole country; South Carolina was second, with 3,793,387, or 13 per cent.; North Carolina was third, with 3,124,456, or 11 per cent.; Rhode Island fourth, with 2,455,304; Georgia, 1,860,905; New Hampshire, 1,350,455; Connecticut, 1,332,991; New York, 1,024,114; Maine, 1,010,535.

Massachusetts leads in the consumption of cotton, North Carolina is second, South Carolina third, Georgia fourth, New Hampshire fifth, Alabama sixth, and Rhode Island seventh.

SILK

The derivation of the term "silk" points authoritatively to the East as the place of origin of the most costly of all fabrics. It comes with various changes from Seres, the name given the ancient Chinese and the inhabitants of Eastern Asia by the Greeks, Syrians, and Persians; and in the Greek it took the name *serikon*, which in Latin became *sericum*, and by the insertion of l for r, in the language of the West, changed to *selicum*, *silic*, and eventually silk.

The Greeks and Romans supposed it was a woolly substance spun from the leaves of trees, and for fifteen hundred years after it became known in Western Europe the opinion that it grew upon a tree or was obtained from the bark continued to be the belief. Not until the sixth century did two Nestorian monks, who brought silkworm eggs from China to Constantinople, make the truth known.

Silk is a liquid substance secreted from their food by various insects of different families, but principally by the spider and the silkworm of the Bombycidæ family. It is held in cells or tubes on each side of their bodies and drawn out through minute orifices called spinnerets. As these

threads, from two to six in number, are pulled out, they harden to form a stronger thread. The thread is used by spiders as a method of locomotion or as a net to trap their prey; while others, and many of the caterpillars, weave it into cocoons to protect their eggs and into which they may withdraw when about to go into the chrysalis state, as in the case of the true silkworm.

The number of insects that yield silk is very large, there being no less than one hundred species of the spider family. None except the true silkworm produces a silk that can be spun profitably, although the silk of the spider family is of most exquisite quality, and has often been used for making small articles of silk. The small amount of the product and the difficulty of controlling spiders make such use impracticable.

The best silkworms are those which feed on the leaves of the white mulberry-tree, and go through their changes but once a year. The life history of the silkworm is like that of the whole moth family. The female, after coming from the cocoon, lives three or four days or a week, and then lays four or five hundred small whitish or yellow eggs. A gummy substance holds them to the leaves or other object on which they may be laid, and, when their food is ready, they are hatched and at first are not over one-twelfth of an inch in length. They go through the various changes of moulting and casting their skin about four times in twenty or fifty days. At their full growth they are about three inches in length, and then they find a place to spin their cocoon, finishing it in three to six days and going into the chrysalis. In twenty to forty days the insect emerges from the cocoon, and in a few days is ready to lay her eggs. The cocoons are unravelled, reeled, carded, spun, doubled or redoubled, cleaned, and twisted into the thread for weaving or sewing.

The greatest producer of manufactured silk is probably China, though no complete statistics are available; and



Caterpillar.



Male moth.

This species produces
sively the green
sible wild silk
caterpillars feed on oak
other trees belong
order. The species is
hed to the Tusar of India.
the Tusar of India. It
in a semi-domesticated
its native country.



Female moth



Cocoons from New Chwang district, China.

The Chinese Wild Silk Moth.

Habitat, China, Turkestan.

THE EGGS, CATERPILLAR, COCOONS AND MOTH OF THE SILKWORM
(From the Commercial Museum, Philadelphia)

The eggs, caterpillar, cocoons, male and female moth, of the wild silk moth of China and Turkestan. This species produces the large amount of valuable wild silk of China. The caterpillars feed on oak and allied trees, and the species is closely related to the Yamamai of Japan and the Tusar of India. It is raised in a semi-domestic state in China.

second to China is the United States, for since 1905 France has fallen into third place; while the nations that are most productive of raw silk in the order of their output are China, Japan, and Italy. In 1909 the world produced 85,048,000 pounds, of which China raised 35,697,000; Japan, 30,135,000; Italy, 9,373,000; France, 1,486,000; Austria-Hungary, 838,000; and British India, 513,000. The value of the silk manufactures of the United States for 1909 was \$196,475,000, capital invested was \$144,799,000, and the number of employees was 104,261.

EARLY HISTORY OF SILK

Like wool, cotton, and flax, the date of the origin of silk is uncertain. Very early it was in use in the East, and well into modern times it continued to be the fabric used exclusively by the nobility, or royalty. In fact, the earliest historic reference has a royal setting, and comes from the East. According to Chinese history, silk was used in China thousands of years before Christ.

The Chinese legend regarding the discovery of the use of silk in a "summary of the principal Chinese treatises upon the culture of the mulberry and the rearing of silkworms," compiled and translated from Mr. Stanilas Julien's French edition of Chinese Treatises, printed 1836 at Washington, D.C., is as follows:—

"This great prince Hoang-ti was desirous that Si-ling-chi, his legitimate wife, should contribute to the happiness of his people. He charged her to examine the silkworms, and to test the practicability of using the thread. Si-ling-chi had a quantity of these insects collected, which she fed herself in a place prepared solely for that purpose, and discovered not only the means of raising them, but also the manner of reeling and of employing silk to make garments."

"It is through gratitude to so great a benefit that posterity has deified Si-ling-chi, and rendered her particular

honors under the name of 'The Goddess of Silk-Worms.' To the present time it is said that the empress of China, on a certain day of the year, goes through the ceremony of feeding the silkworms and rendering homage to Si-ling-chi, as 'Goddess of Silk-Worms.'"

The date of this, according to Chinese chronology, was 2700 B.C., but more accurate records make it about 2640 B.C. Whichever date is correct, it is certain that the manufacture of silk products goes back to a very early date.

To the Empress Si-ling-chi the Chinese also ascribe the invention of the loom. It was not until the third century A.D. that the Japanese learned of the manufacture of silk through the Coreans, and then they sent Coreans to China to engage people to teach the art to the Japanese. Three Chinese girls were brought back, who taught the Japanese court and people the art of plain and figure weaving.

The art subsequently spread to India, where it was introduced by a Chinese princess, who carried the silkworm eggs and seeds of the mulberry-tree concealed in the lining of her head-dress; and by India the silk was made known to Europe. For many centuries, however, the Chinese had a monopoly of the industry, and Tartar caravans carried loads of silk, which they sold to Persian and Arabian traders.

The knowledge of silk was brought to Europe by Alexander the Great (356 to 323 B.C.) when he returned from India; and Aristotle gave full particulars of the silkworm, describing it as a horned worm which he called Bombyx. It passed through several transformations and produced Bombykia. According to Aristotle the Island of Cos was a flourishing seat of early silk manufacturing.

The knowledge of silk brought by Alexander seems, however, to have been lost, for the Romans later obtained silk from the Greeks and thought that it was a fleece that grew upon trees. This became the early belief of the

western world. Nearchus evidently confused silk with cotton; Virgil supposed silk was carded from leaves; Dionysius thought it was combed from flowers; while Pliny (23-79 A.D.) describes the Bombyx, but makes it a native of Assyria.

It is impossible to say when silk came into use among the higher classes at Rome, but there is authority for believing that it was first worn in Rome during the supremacy of Julius Cæsar (61-44 B.C.), and from then on became the dress garment of the Roman nobility. Its price was very high, selling for its weight in gold. Nevertheless, silk had such a vogue among the wealthy classes that the Emperor Tiberius prohibited men from wearing it on the ground that it was effeminate, and Roman satirists denounced the wearing of the transparent silk of Cos by either sex because of the indecency. Emperor Heliogabalus, in 222 A.D., shocked his subjects by appearing in a garment of thin silk, while Emperor Aurelian in 273 A.D. refused the plea of his wife for a single garment of purple silk on the ground of extravagance, saying that a pound of silk sold for its weight in gold, and that wearing it would be an example of extravagance.

Ammianus Marcellinus, 380 A.D., stated that silk had come within the reach of the common people. A decree of the Emperor Justinian (518-565 A.D.), that silk should be sold for eight pieces of gold per pound, or about \$15, together with a war with Persia whose traders were the carriers of silk, cut off all importation and ruined the silk merchants.

The situation was relieved by two Persian monks, who had become familiar with the silk industry while on a religious embassy to the Chinese, and who informed Justinian that they could secure from China the means of establishing the industry. Accordingly, at Justinian's command they returned to China, observed carefully the whole process of the industry, and 536 A.D. brought back to Constanti-

nople the seeds of the mulberry-tree and the eggs of the silkworm concealed in hollow staves, and thus was the silk industry established in Europe. Byzantine silk soon came much in demand for ecclesiastical purposes.

The silk industry spread from Constantinople to Thebes and other Grecian cities, and the Arabs and the Saracen princes, who obtained the knowledge of silk-making from the Persians, introduced it into Northern Africa, Spain, Portugal, and Sicily. By the tenth and eleventh centuries the output of Spain and Sicily was large, and workmen subsequently carried the industry thence to Italy.

The conquest, by the Venetians in the twelfth century, of Constantinople, where the rarest kinds of silk were made, transferred the early European silk industry to Venice, whose looms then began to supply Europe. The principal seats of the silk manufacture in the fourteenth century were Lucca, Modena, Bologna, and Florence. Genoa also had a flourishing trade.

By 1251 silk garments were generally used by the higher classes in England. A thousand knights appeared in silk at the marriage of Henry III.'s daughter, and silk was worn by the wealthiest citizens. The earliest official recognition of silk in England occurs in an act of Edward III. (1336-60) which restricted merchants to manufacture or trade in a single line of goods, and made imperative a declaration of the line they would engage in before a certain date. Again in 1455 an act was passed prohibiting the importation of silk for five years.

Although the silk trade was begun at Tours and at Lyons, France, in the thirteenth century, it was not until the close of the sixteenth century that the silk production was well established there. It is said that the first white mulberry-tree planted in France was brought there by Guipane de St. Aubon from Syria, about 1147, on his return from the Second Crusade, and was planted three leagues from Montmeliart. This tree was still standing in 1810. From the twelfth

century on, efforts were made by the French kings to establish the production of silkworms and the growth of the mulberry-trees, but without success until the reign of Henry of Navarre.

This energetic monarch planted about Paris a large grove of mulberry-trees under the direction of Ollivier de Serres, a skilled agriculturist, distributed the eggs, and offered bounties for silk and the most productive trees. The experiment failed, and the people, irritated by the loss of profit, rooted up the trees, destroyed the worms, and gave up the industry.

Persisting, however, the king converted a large orange grove on his own estate into a mulberry grove, and soon had a quantity of silk. His success shamed the people who had given up silk growing, and they resumed the work again under skilful teachers, and soon acquired success; but it had cost the king about two hundred and fifty thousand dollars.

Colbert, the great minister of Louis XIV., kept a guardian eye over the silk production; but the Edict of Nantes almost ruined the industry, as it drove almost four hundred thousand Huguenots, most of whom were engaged in the work, from France to England, Germany, and Switzerland, and of this number almost one hundred thousand went to England.

The first efforts to start the industry in England were unsuccessful, but the introduction of the Italian method of throwing, or twisting, silk soon made it possible for English silk to replace the French in the European market, and it was years before France regained her supremacy. Silk had, however, by the middle of the sixteenth century come into common use among the nobility in England, and Queen Elizabeth and her court were the first to wear silk stockings.

"I have written into Spain for silk hose both for you and my lady, your wife, to whom it may please you, I may be remembered," wrote Sir Thomas Gresham, April 30, 1560, from Antwerp to Sir William Cecil, Elizabeth's great

minister, and the hose sent soon after were black. Until the time of Henry VIII. stockings were of ordinary cloth, and the king's were yard-wide taffeta.

Sir Thomas Gresham sent Edward VI. a pair of long Spanish silk stockings. In the second year of Queen Bess's reign "her silk woman," Mistress Montague, gave the queen a pair she had knit of black silk for a New Year's gift. After the queen had worn them a few days, she was so pleased she sent for Mistress Montague and asked her "where she had them," and if she could help her to any more, who answered, "I made them very carefully of purpose only for your Majesty, and seeing these please you so well I will presently set more in hand."

"Do so," quoth the queen, "for indeed I like silk stockings so well, because they are so pleasant, fine, and delicate, that henceforth I will wear no more cloth stockings," and from that day she wore silk.

Among the other weavers which the Edict of Nantes drove from France to England was a large number of silk weavers, and the manufacture of broad silks began in England during the reign of James I.

Such a foothold had the industry obtained by 1701 that acts were passed prohibiting the importation of silk from France, China, Persia, and India because there were as good made in England. It was not until 1715 that a silk throwing mill was established in England.

The silk machinery used in England until the beginning of the eighteenth century was crude and ineffective. Much of the organzine silk warp was imported from Italy. In 1717, however, John Lombe went to Italy, and, disguised as a workman, secured employment in one of the mills. By bribing workmen, he obtained an opportunity to examine the machinery privately when it was not working, and thus learned all the details of construction. He was discovered eventually, and obliged to flee with his accomplices to England. He secured patents for fourteen years, and in

1719 erected a silk mill on the Derwent at Derby. In 1721 bounties were granted on home production, and in 1749 silk from Georgia and the Carolinas was admitted free of duty.

SILK INDUSTRY IN AMERICA

Long before this efforts were made to start silk culture in America. Cortez in 1531 brought the mulberry-tree and silkworms to Mexico, where both were successfully grown, silk spun and woven, and sent to Europe. By the end of the century, however, the industry had ceased.

The visionary James I. of England became very much interested in the cultivation of silk in Virginia, and in 1619 ordered the shipment of silkworms to that colony, urging their cultivation in place of tobacco, offering bounties for the silk produced, and placing penalties for the failure to plant mulberry-trees. The next year saw the industry established, and it continued thriving moderately under the stimulus of premiums offered by the Colonial Assembly until 1666, when the bounty was withdrawn. The culture rapidly decreased and soon was abandoned.

At one time the Assembly offered ten thousand pounds of tobacco to the planter who would export two hundred pounds of raw silk or cocoons in a single year, five thousand pounds of tobacco to the producer of one thousand pounds of raw silk, and four thousand pounds of tobacco to any planter who would devote himself exclusively to silk raising.

It is not known that the premiums were ever earned. Some silk was sent abroad, and there is a tradition that one of the King Charles of England had a robe made of it. Even after the culture of silk was abandoned in Virginia, there are stories of men appearing in silk waistcoats or with handkerchiefs of their own raising, or ladies appearing in a gown of native grown silk.

The failure of Virginia seemed only to spur on some of the other colonies to engage in silk culture, and the other

colonial governments offered various inducements for the spread of the industry. By 1712 the colonial exports averaged five hundred pounds annually. In 1732 Georgia's colonial government allotted a piece of ground as a nursery for white mulberry-trees, and granted lands to settlers on condition they plant one hundred white mulberry-trees on every ten acres cleared.

The result was that in 1735 Governor Oglethorpe took eight pounds of silk to England which was used as a dress for Queen Caroline. The industry became established in South Carolina in the same year, and in 1762 began in Connecticut, although as long before as 1734 the Connecticut General Assembly had passed an act for the encouragement of silk raising, which was to continue in force for ten years.

The removal by the English government in 1749 of all duties on silk imported from Georgia or Carolina led to increased importations, and by 1759 large quantities of raw silk were being sent by the colonies to England, often commanding higher prices there than the best Italian silk.

A reeling establishment was founded at Savannah in 1750, and the good quality of the Georgia silk was doubtless due to a visit made the year before by Signor Ottolengi, an Italian expert, who was sent to Georgia to establish a silk filature for reeling, doubling, cleaning, and twisting the silk. The quantity of the cocoons received at the filature was so great that in 1759 the export of raw silk from Georgia exceeded ten thousand pounds, and the quality was so good as to bring three shillings more per pound in London than any other silk in the world. The silk culture reached its height in Georgia in 1759, and by 1772 had practically ceased. It was not long before cotton had driven silk culture from the South.

Half an ounce of mulberry seed was sent to every parish in Connecticut in 1766, and for a time the legislature offered a bounty on mulberry-trees and raw silk. A piece of

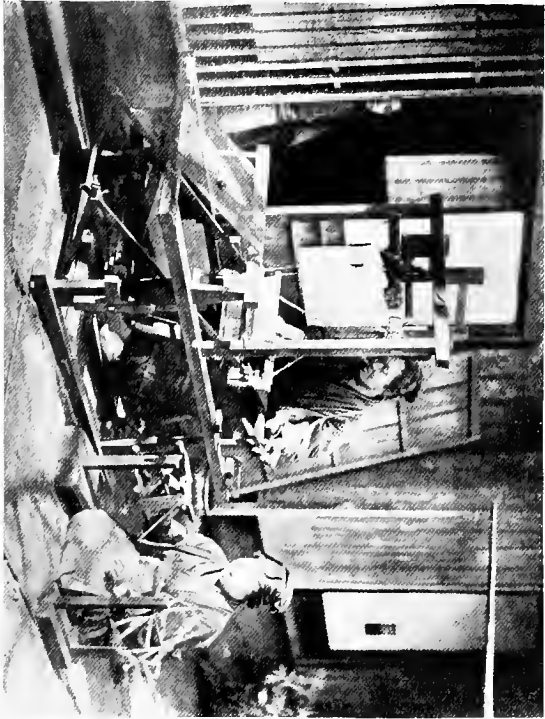

JAPANESE SPINNING AND WEAVING
(From a print in the Peabody Museum, Salem, Mass.)

mantua, 60 yards in length, was spun and woven from her own cocoons in 1770 by Mrs. Susanna Wright at Columbia, Pa., and afterwards worn as a court dress by the Queen of England. By about the middle of the eighteenth century Philadelphia had become an important seat of the industry.

During the Revolution the silk industry languished, and all manufacture ceased, except enough to supply a small local demand. Hardly had the Revolution ended before the industry sprang up with great vigor under the impetus of bounties. Mansfield, Conn., had become an important silk-raising section in the latter part of the eighteenth century, and here, in 1810, the first silk mill in America was set up, as we shall see later.

In 1785 a company was formed in Connecticut for the culture of silk, and also its manufacture. The company which was formed at Mansfield and incorporated in 1789 was called "The Directors, Inspectors, and Company of Connecticut Silk Manufacturers." It included the names of many who are the ancestors of the successful silk manufacturers of to-day.

As the quality of American silk did not keep pace with the Italian, being too fine, uneven, and often defective in color, it became, about 1800, difficult to find a market for it, although by this time silk had become an article of domestic manufacture in the East, many families making their five, ten, and fifty pounds of silk annually. The silk production was greater in Connecticut and Pennsylvania than elsewhere, though New York, New Jersey, Delaware, Maryland, and Virginia also produced all of the domestic silk. The silk was badly reeled on a hand loom and roughly spun on the large wheel used for spinning wool. By 1810 New London, Windham, and Tolland Counties, Connecticut, were turning out \$28,503 worth annually, and half as much more of the waste silk.

Much of the success of the early industry was due to Edmund Golding, an English throwster, who came to

America in 1827 when he was but seventeen. He met Alfred Lilly, whom he told of his previous occupation, and who became interested in him. Golding made sketches of the silk machines used in England, and finally Mr. Lilly, Captain Joseph Conant, William A. Fiske, William Atwood, Storrs Hovey, and Jesse Bingham formed a copartnership, in 1827-28, under the name Mansfield Silk Company, to install and operate machines for making silk. Lilly took charge of procuring the machinery, much of which he made in his own shop and obtained some from regular machinists. It was put in operation under the direction of Golding. A building and power was subsequently obtained in Gurleyville, and this mill was the first in America where the manufacture of silk was commercially successful.

The first silk mill in America, however, was probably that erected in 1810 by Rodney and Horatio Hanks, at Mansfield, where an effort was made, in a building 12×12 feet, to make sewing silk and twist by machinery they had made. But it was not practical. Great difficulties were encountered by the Mansfield Silk Company, as the machinery was crude, and was not adapted to silk as it was then reeled in America. In order to compete with Italian sewing silk, the promoters had to import raw silk from England.

In 1829 the Mansfield Silk Company was incorporated, and thus public attention was directed to it. Among the visitors was a Mr. Brown, an Englishman, who explained the process of reeling and showed how to construct the right kind of a reel. It was very successful, and American silk was found to be of superior quality and became much in demand, mulberry nurseries being established by the company in all the adjoining States. Nathan Rixford made several improvements upon Golding's machines, and for some years was the principal builder of silk machinery. The Mansfield Company was not a success, and was finally dissolved in 1839.

The Connecticut legislature offered a bounty in 1832 for mulberry culture, and fixed the price of raw silk at fifty cents a pound. Maine, Massachusetts, New Jersey, and Pennsylvania soon offered similar bounties. Mr. Golding, with Messrs. Salmon Storrs & Son, later built another mill at Mansfield and equipped it with Rixford machinery. It was successful for more than ten years.

The first successful silk dyers in the United States were Edward Vallentine and Lewis Leigh, who had emigrated from England in 1838. Many processes were improved by them. Vallentine commenced business at Gurleyville, Conn., and gained a wide reputation by the use of new colors and a permanent black. In 1839-40 he moved his business to Northampton, and died about 1851.

The first silk mill in Paterson, N.J., was set up by Christopher Colt, Jr., in 1838, on the fourth floor of Samuel Colt's pistol factory. The first loom for weaving piece goods was built in 1842 by Mr. John Ryle, the father of the present silk industry in America, who started in Paterson, N.J., in 1840. To-day Paterson is the centre of the American silk industry. The real establishment of American supremacy in silk manufacturing dates from 1860, and was the result of French silks being admitted to English markets free of duty. As the English silk throwsters and weavers were forced from their own market, they came here, bringing their skill and machinery with them, and many settled at Paterson. The industry was further favored by the tariff of 1861 and later by the import duty, which ranged from 40 per cent. to 60 per cent. The story of Paterson is told more fully later.

Manufacturing began at Philadelphia in 1815, and in 1824 the Jacquard loom was first used there. By 1830, 3,200 pounds of silk were raised in Mansfield, and in the same year the Chinese mulberry-tree was introduced because of its rapid growth and abundant leaves. Previous to this silkworms in the United States had been fed

on white mulberry-trees. In 1838 power loom weaving began.

An unsuccessful manufactory of silk ribbons from American silk was started in 1829 at Baltimore, but came to a speedy end. John McRae began making silk fringes, tassels, and braids in New York City in 1830.

The beginning of the silk industry at Florence, Mass., was in 1832, when the "Old Oil Mill," which for over a century had stood as a grist-mill on the Mill River, under the direction of Samuel Whitmarsh, an early silk enthusiast, was equipped as a silk mill, with machinery made by Nathan Rixford. The New York & Northampton Silk Company was formed in 1833-34, and among those who took stock in the new company were Augustus and Samuel Russell, who had established the firm of Russell & Co., the foremost American trading house in China.

A brick building was erected and acres stocked with mulberry-trees to supply worms for the raw silk. Mr. Whitmarsh even had two hothouses, one hundred feet long, attached to his house at Northampton for raising mulberry-trees in winter. Whitmarsh became president of the company. Watch ribbons and satin vests were made: some of the heavy black vests were presented to Henry Clay, Daniel Webster, and A. A. Lawrence, who had shown interest in the enterprise.

"I shall make \$250,000 before next winter," said Mr. Whitmarsh in the summer of 1839 to John Ryle, who later became the father of the Paterson silk industry and was then a weaver in Whitmarsh's employ. Before winter the company had failed, and Whitmarsh had neither money nor credit. Although over a hundred thousand dollars was sunk by the company, it eventually paid its debts.

In 1835 the Connecticut Silk Manufacturing Company was formed at Hartford, Christopher Colt being president and largest stockholder. The company collapsed in 1838. Soon after 1844 the Nonatuck Silk Company was organized

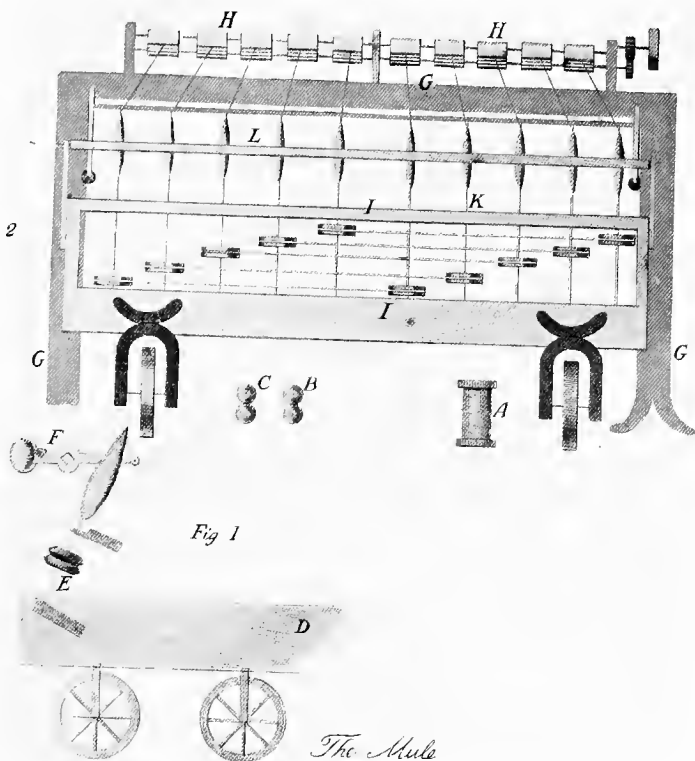

Fig 1

THE MULE

(According to Richard Guest)

Figure 1.—*A*, the roving; *B*, the first pair of rollers; *C*, the second pair, revolving quicker than the first. The roving and rollers are placed on a fixed frame. *D*, movable carriage on which the spindles stand. This carriage recedes from the fixed frame when drawing out the yarn and returns to it when the yarn is copped, or wound upon the spindles. *E*, a spindle. The spindles are turned by strings from a drum, each string turning two spindles. *F*, the drop rod.

Figure 2.—*GGG*, the fixed frame on which stands *III*. The second pair of rollers represented at *C*. *II*, the movable carriage; *K*, the spindles; *L*, the drop rod.

at Florence, with S. L. Hinckley as president and S. L. Hill as treasurer, and since has grown into the plant which makes the famous Corticelli brand of sewing silk.

To the genius and persistence of the Cheney Brothers was due the establishment of the silk industry at South Manchester and Hartford, Conn. They were sons of a farmer, and while boys had become interested in the raising of silkworms. Two became skilful artists, another became a merchant in Providence, while others continued to farm.

Ward, Rush, Frank, and Ralph Cheney in January, 1838, started at South Manchester the Mount Nebo Silk Mills, establishing also orchards, cocooneries, and a magazine called the *Silk Growers' Manual*, which lasted from July, 1838, to July, 1840. After a short time the mill closed, but about 1841 was reopened with new machinery. Sewing silk, twist, ribbon, handkerchiefs, and later broad goods were made, and soon spun silk was being fashioned into pongees and handkerchiefs. Under the beneficial effect of the Civil War tariff the brothers were able to establish themselves as makers of the cheapest and most serviceable silks of their kind on the market. The mill was built at Hartford in 1854, and since the firm of Cheney Brothers has grown into the leading firm of its kind in America.

The silk industry of William Skinner dates from 1848, when he went from Holyoke and established his mills at Northampton. In 1854 he moved to Haydenville and built his Unquomok Silk Mills, which were among the largest in Connecticut. They were swept away May 16, 1874, by the bursting of the Williamsburg Reservoir on the Mill River. One hundred and forty-eight lives were lost, and a million dollars' worth of property, including all of the town of Skinnerville, as the village where the mill was located was called. He started again at Holyoke, and the firm has become one of the best known in the country.

A disastrous silk speculation broke out in the Eastern

States in 1836. Cuttings two feet long sold from \$25 to \$500 per hundred. All kinds of crops were displaced to make room for it: one nurseryman ordered 5,000,000 trees from France, sending \$80,000 in advance payment. After running madly for three years, the speculation collapsed, so that in 1840 trees were sold for five cents each, thousands were ruined, and the silk industry checked for years.

The high price of labor has hampered production of raw silk in the United States, so that it has not kept pace with the manufacture. Much of the raw silk comes from China, Japan, Bengal, and other parts of the East, where labor is cheap. An attempt was made in 1854 to raise silk in California. Blight of the mulberry-trees has, however, prevented successful silkworm culture in the United States, and to-day practically all of the raw silk used by the United States is imported.

CHAPTER III

FACTORY SYSTEM

GROWTH OF THE FACTORY SYSTEM—EARLIEST RECORD OF ENGLISH FACTORY—ENGLISH NAMES DERIVED FROM INDUSTRY—CAUSES OF THE CONCENTRATION IN LANCASTER—SEPARATION OF AGRICULTURE AND SPINNING AND WEAVING—EARLY RELATIONSHIP OF EMPLOYER AND EMPLOYEE—INVENTIONS AND THE FACTORY SYSTEM—INFLUENCE OF FACTORY ON ENGLISH SOCIAL LIFE

It is not easy to find in ancient or mediæval history any perfect parallel to the factory system as we understand it and as it developed in England and in America. The modern conception of a factory—a place where products are produced by power for commercial use—had no existence prior to the invention of the steam-engine save in a very primitive way. Here and there we find organizations of workmen producing goods jointly for commercial use, but very few traces of machines are to be found save in the production of primitive textiles. There were, it is true, ancient guilds just as there were mediæval guilds. We know scarcely anything of the working of the ancient guilds, but our knowledge of the mediæval guilds is somewhat comprehensive. These had full and even despotic control, a completeness of organization with which the modern trade union is entirely unfamiliar. They fixed often not only prices, but conditions of work, and in some instances there grew up within the industrial centres controlled by these mediæval guilds industries in which men collectively worked at the production of commercial products. And here we can find traces of the factory system, at least as far as the collective labor of workmen is concerned. But the factory system as we now understand it

was the offspring of the centralization of industry brought about by a combination of three factors,—the growing skill of operatives, the combination of capital, and the use of machinery; but, as the industry of the ancient and mediæval world lacked steam-driven machinery, it never attained the true factory system.

Nevertheless, an embryonic factory system existed among the Romans in the time of the Cæsars, and is described by Ferrero. He says “that it was the duty of a woman, if she was nobly born, to know all the arts of good house-keeping, and especially, as most important, spinning and weaving. The reason for this lay in the fact that for aristocratic families, who were in possession of vast lands and many flocks, it was easy to provide themselves from their own estates with the wool necessary to clothe all their household, from masters to the numerous retinue of slaves. If the materfamilias knew sufficiently well the arts of spinning and weaving to be able to organize in the home a small factory of slaves engaged in such tasks, and knew how to direct and supervise them, to make them work with zeal and without theft, she could provide the clothing for the whole household, thus saving the heavy expense of buying stuffs from a merchant,—notable economy in times when money was scarce, and every family tried to make as little use of it as possible.”

A mediæval trace of the factory system may also be found among the silk throwsters in Italy, where craftsmen in the industry congregated in certain localities. Although the beginning of the factory system was an early specialization of parts of the industry in the hands of different persons, its growth and development were slow until the manufacture of cotton became a leading industry, and the invention of the steam-engine and textile machinery so greatly increased the production.

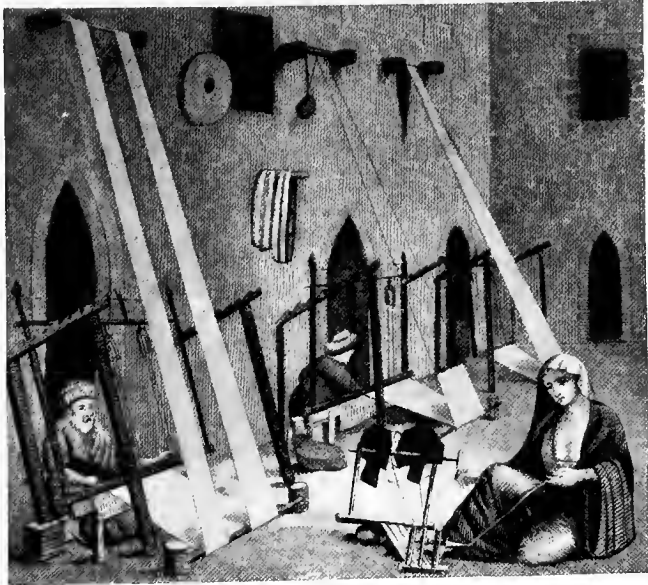
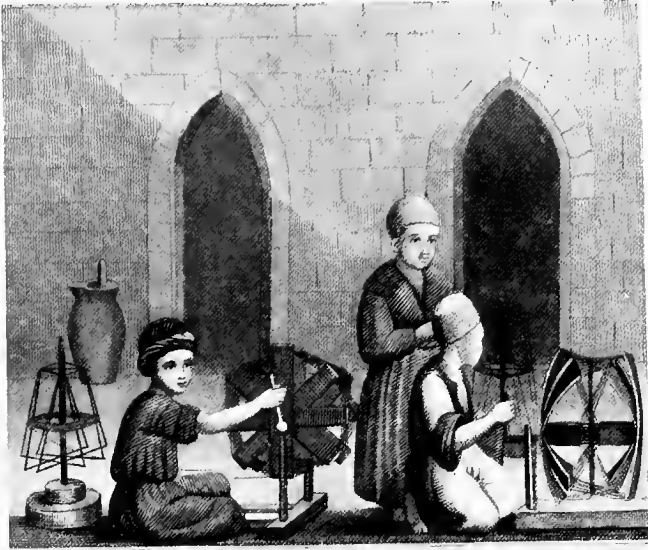

ANCIENT EGYPTIANS SPINNING AND WEAVING
(From an old print)

EARLIEST RECORD OF ENGLISH FACTORY

The first industry of which there is any record in England that might be called a "factory system" was run by John Winchcombe, popularly known as "Jack of Newbury." So famous did he become that he entertained Henry VIII. and his first wife Catherine in his Newbury home. Winchcombe, who died in 1520, is described in Fuller's "Worthies" as "the most considerable clothier without fancy or fiction England ever beheld. His looms were his lands, whereof he kept one hundred in his house, each managed by a man and a boy."

So great was the fame of his factory that it was described in the following poetic lines written while his firm was still a household word in fashionable London:—

"Within one room, being large and long,
 There stood two hundred looms full strong;
 Two hundred men, the truth is so,
 Wrought in these looms all in a row;
 By every one a pretty boy
 Sat making quills with mickle joy.
 And in another place hard by
 A hundred women merrily
 Were carding hard with joyful cheer
 Who singing sat with voices clear;
 And in a chamber close beside
 Two hundred maidens did abide.

.
 These pretty maids did never lin,
 But in their place all day did spin!

.
 Then to another room came they
 Where children were in poor array,
 And every one sat picking wool,
 The finest from the coarse to cull;
 The number was seven score and ten,
 The children of poor silly men.

Within another place likewise
 Full fifty proper men he spied,
 And these were sheer men every one
 Whose skill and cunning there was shown!

.
 A dye-house likewise he had then
 Wherein he kept full forty men;
 And also in his fulling mill
 Full twenty persons kept he still."

As Thomas Fuller says, in his "History of the Worthies of England": "Well may his house make sixteen clothiers' houses, whose wealth would amount to six hundred of their estates. He built the church of Newbury from pulpit westward to the tower inclusively, and died about 1520. Some of his name and kindred of great wealth still remain." In the expedition to Flodden Field against James, King of Scotland, he marched with one hundred of his own men, "as well armed and better clothed than any, to show that the painful to use their hands in peace could be valiant and employ their arms in war."

At first fabrics were a by-product of agriculture in England, for the farm homestead was the seat of the textile industry. The males of the household raised the flocks, while the females spun the yarn and wove the fabrics; and so the industry thrived and prospered for hundreds of years, giving occupation and income to thousands of the agricultural class. As time went on, the farmers of certain sections, particularly about Bury, Oldham, Preston, Manchester, and Chester, became the more expert in the art, and soon the beginning of the factory system appears in a separation of spinning from weaving, the two originally being done by one person. And little by little there came a further differentiation of work in the process not only of manufacturing, but also of merchandising the product, and this has left its trace in many English names.

ENGLISH NAMES DERIVED FROM INDUSTRY

To the old occupation go back many names which originally indicated the part their bearer performed in the textile industry. Thus the name of Shepard, which with variations of spelling is a common one, may be traced to the shepherd or sheepherd, who cared for the flocks, and the names Shearer, Sheerman, Shurman, and the like, came from the man who sheared or clipped the sheep.

So also the names Stapler, Wool, Wooler, Woolman, or Wollsey were derived from the merchant to whom the wool was sold; and the carrying it from place to place originated those of Carter, Packer, or Carrier. The wool was turned over to Carders and Combers, Kempers, or Kemsters, and passed next to Spinners, and then to Weavers, Weevers, Webbs, Webbers, or Websters. The nap was brought out by "teasing," by the Teasers, Tosers, Teasers, or Taylors, and then dyed by the Dyer, Litter, or Lister.

The fulling or shrinking process was done by the Fullers, Fullertons, Fullersons, or Fullmans, assisted by the Walkers, who trod it with their feet, while it was beaten with bats and mallets by the Beaters, Beatermans, Bates, Batteman. In time the special work in which the workmen showed special skill gave them the names by which they and their descendants have been known.

CAUSES OF THE CONCENTRATION IN LANCASTER

The unpleasant climatic conditions of Manchester and the surrounding towns near the Irish Sea, affording the right degree of humidity for the best linen and cotton manufacture, made the section ideal for textile work and not so suitable for agriculture or outdoor work. So it was that the farmers thereabouts early turned their attention to spinning and weaving cotton.

As early as 1641 the people of Manchester were "in the

habit of buying linen yarn from the Irish, and, after weaving it, returning it for sale in a finished state. They also bought cotton-wool that came from Smyrna to work into fustians and dimities." These fustians, with tuckings, tapes, etc., made the staple trade of Manchester in the early part of the seventeenth century.

An eye-witness, writing about 1770, says: "The land in our township [Mellor] was occupied by between fifty and sixty farmers, and out of those fifty or sixty there were only six or seven who raised their rent directly from the produce of their farms. All the rest got their rent partly in some branch of trade, such as cotton or linen or spinning and weaving woolen."

SEPARATION OF AGRICULTURE AND SPINNING AND WEAVING

At this period many of the farmers of Lancashire were engaged wholly in spinning and weaving, save during the few weeks of harvest. And soon "there were a number of master [cotton-linen, fustian] manufacturers, as well as many weavers who worked for manufacturers and at the same time were holders of land or farmers."

A few cottagers held no land and worked for manufacturers, but many held small pieces of land and worked for themselves. The situation had thus assumed a phase in which farming had become wholly subordinate to the textile industry, although most of the weavers occupied small parcels of land for which they were able to pay high rents by combining a little farming with much spinning and weaving.

This relation between agriculture and the textile industry continued in a lessening degree until well into the first quarter of the nineteenth century. From the beginning of the last quarter of the eighteenth century the growth of the factory system became more and more pronounced. The development first showed itself in a severance of the



BOWING OF COTTON, AS PRACTISED IN INDIA AND CHINA



A HINDU WOMAN SPINNING COTTON YARN ON THE PRIMITIVE
WHEEL OF INDIA

(Both illustrations from an old print)

agricultural connection through the concentration of the weavers in hamlets and towns, and this was brought about by the higher skill required by the finer fabrics which were more and more in demand. As early as 1727 Daniel Defoe could write of Manchester, "The grand manufacture which has so much raised the town is that of cotton in all its branches."

It was soon learned that the rough work of farming made the hands of the weaver less skilful, and the weaver found also the needed ability required close application, and that much could be gained from the study of the work of other weavers.

As the looms became more complicated with the improvements that inventive genius added, considerable mechanical work was often called for, and this necessitated being near a mechanic. Then, too, as the spinners and weavers began clustering together, the buyers of fabrics turned to these centres for their goods, so that it became easier to find a market for one's goods when one was part of a community of weavers than when one lived at a distance.

The fact that since the introduction of the industry in England a portion of the artisans did nothing but spin and weave, and were early associated in guilds, doubtless had a decided influence in bringing about a separation of the two occupations,—the textile industry and farming.

EARLY RELATIONSHIP OF EMPLOYER AND EMPLOYEE

How early the relationship of employer and employee sprang up it is impossible to determine, but there is little doubt that to a slight degree it was in existence from the earliest days.

The old apprenticeship system, too, had its place in fixing the relations between employer and employee. The apprentice generally lived with his employer, and thus came

in closest contact not only with his mode of life, but his method of business management. And thus, when the apprentice set up for himself, he perpetuated the system of business under which he was trained.

Contemporaneous with the growth of the factory system was the greater development of the relation of employer and employee. While there always was a time when employer and employee existed, from the first part of the eighteenth century the system grew rapidly, and was given additional impetus by the increased demand for better fabrics and the growing costliness of the complicated machinery which was invented.

By 1740 spinning was being done largely by separate artisans, who were rapidly constituting a distinct class from the weavers; and both classes were furnishing many journeymen, who were working in small shops for others or were being paid by the piece for what they made from material supplied by Manchester merchants. Still others brought their own raw material, and sold the finished products to the growing merchant class. This class of small journeymen manufacturers was eventually driven out, as the growth of the industry required more and more capital, and the consumer and producer were brought more closely together by organizations of capital. At first most weavers constructed and owned their looms. Later many hired them, and in some places lodgings were let with a loom, just as to-day lodgings are let with a piano.

As merchants began to call for different kinds of fabrics, it became the custom for the masters to provide reeds that ranged in fineness with the fineness of the loom, and also to furnish the other changeable parts. Another step toward the control of the industry by the holders of capital or the merchant class was the supplying of the warp by the Manchester merchants. The lack at first of the water frame precluded the spinning of the warp of cotton of sufficient strength for weaving, and warps were therefore of either

linen or wool and made by hand either in the neighborhood or were imported from Germany, Ireland, or Scotland. Until warping mills were introduced, the weaver prepared the warp for the loom; but, after warping mills sprang up, the merchants supplied them ready for the loom. This specialization of work was largely supported by the merchants, who also could judge what warps would be required by their fabrics, and were better able to judge the amount of goods needed. This change, from that of the weaver supplying or buying his own warp to that of the merchant furnishing the warp to the weaver making his cloth, took place about 1740, and led to the firm establishment of warping mills, which, however, existed in limited numbers during the seventeenth century.

Concerning the weft, it was found best by the merchants to give the weaver full responsibility for his yarn. The cotton wool was therefore furnished, and women and children cleaned, carded, and spun the cotton in their homes. Dealers who attempted to supply the yarn ready for the weft found that the spinners could hide defects which often gave the weavers excuse for the production of inferior goods. And frequently weavers placed the responsibility for poor work upon defects they claimed existed in the weft.

“Willowing” was the name given the cleaning process, and it was so called because the cotton spread on a light hammock of cords, called the bowstring, was beaten with willow switches. The process dated back to prehistoric times. Cotton for fine spinning was carefully washed, and was always soaked with water and dried so that the fibres would cling together.

As the weaving became more complicated and arduous, men early took the place of women, who cast the shuttle from hand to hand, as was done from remote time. In the making of broadcloths two weavers were required, as the distance was greater than one man could stretch.

All of these factors were working toward the creation of

the factory system as now understood. But the greatest factor was the invention of the steam-engine, of the fly shuttle, the spinning jenny, the mule, and the power loom, all of which made possible the production of fabrics on a scale which necessitated many artisans under one direction and the employment of larger capital than weavers could supply.

INVENTIONS AND THE FACTORY SYSTEM

The era of invention brought about a more rapid development of the factory system as well as greatly increased concentration of the industry in the centres where it was already established.

The father of John Kay, who invented the fly shuttle, had a woolen manufactory at Colchester early in 1700, and already manufacturing in mills was in process in other parts of England. ↓ A great impetus was given the movement by Richard Arkwright, who has been called the father of the factory system. It was to his executive and financial ability, quite as much as to the inventive genius he displayed in the improvement of the spinning frame, that this was due. The first practical cotton mill in the world was erected by him in 1769 at Nottingham and was turned by horses. One had already been built in 1764 by James Hargreaves, who invented the spinning jenny, but it was not practical.

Water power was already beginning to supply the power to the few mills in existence, and in 1771 Arkwright erected a new mill at Cromford, which was turned by the river Derwent, and was supplied with a cylinder card machine and a spinning frame, which could roll as well as spin, and which was called a water frame from the power that supplied it.

The machines thus grouped at Cromford made it possible for the first time to accomplish the whole operation of cotton spinning in one mill, the first machine receiving the cotton



DOMESTIC FLAX WHEEL

An old German invention, commonly called the Saxony, or Leipzig, wheel. In some instances two spindles were attached to the same wheel, enabling the spinner to form a thread with each hand.



HINDU SPINNING AND WEAVING

(Both illustrations from old prints)

wool as it came from the pod, and the last winding the cotton, twisted in firm hard yarn upon the bobbins. The labor used was largely juvenile, as it was found that children were more dexterous in tying the broken ends at the rollers, their small and sensitive fingers being more adapted for the work.

Arkwright's invention, together with Crompton's, gave the cotton industry a great boom, and factories sprang up everywhere in Lancashire, changing the rural aspect of the land into a collection of tall chimneys, brick buildings, and city streets. Everywhere operatives became merely the employees of the masters of capital.

Cartwright's invention of the power loom in 1785-86 further accelerated the spread of the factory system, as it brought spinning and weaving again under one roof.

Then there was also the application for the first time in 1785 of Watt's steam-engine to cotton manufacturing. It is interesting to note here that the first electric-driven spinning mule in Lancashire was that of the Acme Spinning Company's at Pendlebury, and was started 1895. Power was supplied from Outwood, five miles distant. Of the 2,000,000 horse-power now used in the textile mills of the United States, 500,000 is produced by electricity.

INFLUENCE OF FACTORY ON ENGLISH SOCIAL LIFE

No less than one hundred and forty-three water mills in 1788 were making cotton in Lancashire, Derbyshire, Nottingham, Yorkshire, Cheshire, Staffordshire, and were rapidly increasing. The adjustment of the factory system to English life during the last years of the eighteenth century and the first years of the nineteenth century led to much trouble, in which property was destroyed and riots occurred. In fact, Carlyle in his essay on Chartism depicts the miseries that involved the handicraft workers when machinery came into use. Thousands were thrown out of employment in the

crowded textile centres, and much suffering occurred, which led to the smashing of machines and the wrecking of mills, and it was some years before the factory system became a smooth part of the mechanism of England's industrial life.

The influence of the factory on social conditions in England is admirably described in Lincoln's monograph on "The Factory." At first in England the factory towns were sinks of unhealthy conditions. Not alone was refuse allowed to accumulate on the streets, but conveniences of the most primitive kind were lacking. A workingman's family lived mainly upon tea, bread, and boiled potatoes, to which occasionally meat of some kind was added. The members of a family ate from a common dish, more like animals than human beings. They were packed in unsanitary homes where domestic comfort was a stranger, and squalor and debauchery were common. Few over forty years old were fit for work, and it was only when Parliament took cognizance of the conditions and public opinion began to assert an influence that the terrible concomitants of the factory were removed.

It had this effect upon England. Finding the people divided primarily into two classes, dependants, or serfs, and the upper classes, it created from the dependent class the great middle class. In many cases, tradesmen and manufacturers were lifted into the nobility and an interest created in political affairs on the part of the working classes that did not exist before. It found England a nation of agriculturists and made it an empire of world traders.

By the beginning of the nineteenth century the factory system under the control of capital was firmly established, and here we shall leave it and consider briefly the era of invention which so greatly developed the textile industry during the eighteenth and early part of the nineteenth centuries.

CHAPTER IV

ERA OF INVENTION

ERA OF INVENTION—EARLY IMPROVEMENTS IN TEXTILE MACHINERY
—JOHN KAY—PAUL AND WYATT—JAMES HARGREAVES—RICHARD
ARKWRIGHT—SAMUEL CROMPTON—EDMUND CARTWRIGHT—IN-
VENTIONS OF KNITTING MACHINES—IPSWICH MILLS—JOSEPH
MARIE CHARLES JACQUARD—MACHINES FOR SPINNING FLAX—
JAMES WATT—ELI WHITNEY—IMPROVEMENTS OF THE BASIC
MACHINES, AND FURTHER INVENTIONS—BLEACHING—DYEING—
PRINTING—MERCERIZING PROCESS

The use of the distaff and spindle was the first step in the invention of textile machinery, and began at so very remote a time it is impossible to fix it. Earliest records on stone, brick, papyrus, of the Assyrians, Babylonians, and Egyptians, picture the use of the rock, or distaff, and the spindle, and Solomon, Homer, and Herodotus frequently allude to it. The distaff is said to have been introduced into England by Anthony Bonvoise, an Italian, during the twentieth year of the reign of Henry VIII., and then began the making of Devonshire kerseys and Coxal cloths.

The spindle, as it has been from time immemorial, was a round stick of wood about a foot long, which tapered at each end. A ring of stone or clay, or sometimes potato, girded the upper part of it to give it steadiness and momentum when it revolved. At the extreme upper end there was a notch, or slit, into which the yarn was caught. The distaff, or rock, was a longer, stouter stick, around one end of which, in a loose ball, the material to be spun was wound.

The spinner either fixed the other end of the rock in her girdle or carried it under her left arm, so that the coil of material was in a convenient position to draw out to form

the yarn. The end of the yarn, after being prepared, was inserted in the notch, and the spinner set the spindle in motion by quickly rolling it with the right hand against the right leg, and thus throwing it out, spinning in the air. Meanwhile the spinner drew from the rock with the left hand an additional supply of fibre, which was formed by the right hand into a uniform and equal strand. After the yarn was sufficiently twisted, it was released from the notch and wound around the lower part of the spindle, and again fixed in the notch at the point insufficiently twisted. Thus the rotating, twisting, and drawing operations went on until the spindle was full. In this way, spinning was practised in prehistoric and ancient times. And in the self-same way it is to-day done in some remote sections of Scotland. Yarns of greatest fineness and strength are still spun in this way.

The first improvement in this method of spinning was the construction of the hand wheel, in which the spindle, mounted in a frame, was fixed horizontally, and rotated by a band passing around a large wheel set in the framework. Such a wheel has been used from prehistoric times in the East, but was not introduced into Europe until about the fourteenth century.

The earliest manuscript that mentions the spinning wheel was written in the fourteenth century, and is in the British Museum. This wheel was evidently one at which a woman stood, for that which came into general use is said to have been invented in 1533 by a citizen of Brunswick, and was the first wheel at which a woman could sit. Other improvements enabling one to spin with a treadle movement, and thus allowing the spinner to work with both hands free, were added at later dates that cannot be fixed. Thus came into use the spinning wheel as our forbears used it in the homespun industries of New England and as it is still used in the isolated rural districts of Ireland, Scotland, and Europe.

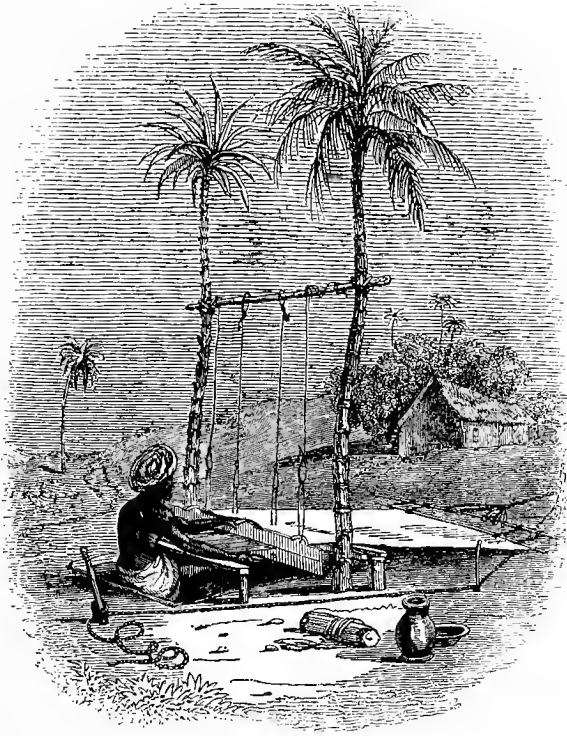

HINDU WEAVER AT HIS LOOM
(From an old woodcut)

It was not long before every woman in England spun, and terms of the industry had become a part of the language. Thus spear side and distaff side of the house became the legal terms respectively for the male and female lines of inheritance. Spinster was and is still the English term for unmarried women. January 7 was jocularly called St. Distaff's Day, or Rock Day, and signified the resumption of spinning after the rest of the Christmas holidays.

EARLY IMPROVEMENTS IN TEXTILE MACHINERY

To Lewis Paul, John Wyatt, James Hargreaves, John Kay, Richard Arkwright, James Crompton, and Edmund Cartwright the textile industry owes the basic inventions which have revolutionized it. It is impossible to say to whom the greatest credit is due, for there is much controversy over the question of whose inventive work takes priority,—whether Paul and Wyatt are entitled to more credit than Kay, Hargreaves, or Arkwright. One thing is certain: for thousands of years before these great, ingenious Englishmen set their minds to work upon the problem of increasing the efficiency of the spinning wheel and loom there was little change in the method and manner of making fabrics. Both spinning and weaving were substantially the same as those practised alike by the savage, by the ancient Chinese, by the Egyptians of Pharaoh's time, and by the spinners and weavers of mediæval or early modern times; and the output was limited by the amount of manual labor that could be brought to it and the capacity of the crude spinning wheel and equally crude loom upon which fabrics were fashioned.

One of the earliest attempts to improve the loom was made in 1678 by a M. de Gennes, a Frenchman. The improvement consisted of an appliance which, like mechanical hands, shot in and out of the warp, and exchanged the shuttle. Another invention was that of grinding the

shuttle through the warp by cog wheels working at each end upon teeth affixed to the upper side of the shuttle. It was known as Swivel's loom, and is described in 1724 as working twenty-four laces at a time and as having been stolen from the Dutch, from which it took its other name of the Dutch loom. A factory in which these looms were installed in 1760 at Manchester, with water as the motive power, failed because of the impracticability of the invention.

While the artisans of Continental Europe were at work upon improvements in spinning and weaving, the Englishmen about Manchester were by no means idle, and to England more than to any other nation are due the basic inventions which have revolutionized the whole textile industry, changing it from a hand occupation of meagre output to one of power machinery with an enormous production.

JOHN KAY

One of the first inventions was that of the fly shuttle, patented May 26, 1733, by John Kay, an English machinist and engineer. Kay's father had a woolen manufactory at Colchester, and the son, who was born in 1704 near Bury, and had been educated abroad, was put, while still a youth, in charge of the mill.

His mechanical bent soon showed itself in the various improvements he made in dressing, batting, and carding machinery, in the development of the Dutch boy and the inkle loom in the mill. By inserting dents of metal instead of cane he greatly improved the reeds of the loom, thus making them more durable and better adapted for the weaving of finer and stronger textures.

The first patent, a new machine for making, twisting, and carding mohair and worsted and for twining and dressing thread, was taken out in 1730, when he was but twenty-six. The fly shuttle, so called because of the speed with which

it could be operated, greatly improved the quality of the cloth, lightened the labor, and yet more than doubled the output.

By the old method the shuttle was cast through the warp from side to side by one hand, caught by the other, and the easy weft thread was driven home by the layer which was operated by the hand that had just cast the shuttle. In making broadcloth with the old loom, which had been in use from time immemorial without improvement, a weaver stood on each side of the warp.

Kay's improvements involved the invention of the race board, which he fixed to the layer under the warp by a shuttle box at each end, with a spindle and picker on each box. A cord passed from each picker to a short lever in the weaver's right hand. It compassed great improvements in the shuttle.

One hand could thus be used to throw the shuttle while the other drove home the weft. The weaver sat in the middle of the loom, and pulled at pleasure the small cord which cast the shuttle from side to side. As spinning was still done on the hand wheel, the demands for the increased output of the loom soon outran the product of the thread. This more than anything else set the spinners to work upon improving the methods of spinning, and yet it was almost forty years before machine spinning was perfected.

The Yorkshire clothiers were the first to adopt the fly shuttle. To avoid paying for its use, they formed an association called "The Shuttle Club," to cover each other's costs, should they be prosecuted. Although Kay's suits against these infringements were all decided in his favor, he was almost bankrupted by the expense to which he was put. So much opposition did the weavers display to the introduction of the shuttle that Kay was forced to leave Colchester and take up his residence in Leeds. But in Leeds the same opposition was shown, and he finally

consigned the spinning and carding machines he had invented to the poorhouse, where the inmates operated them. A mob broke into Kay's quarters, demolished everything they could find, and would have killed Kay, had not two friends smuggled him out, concealed in a sheet. His model of the spinning machine was saved by a Mr. Earnshaw, who subsequently destroyed it as "a very dangerous piece of furniture."

Thoroughly discouraged with his experience in England, Kay went to France, and there resumed making the machines which he had smuggled out of England. In 1764 his son Robert wrote to the London Society of Arts and Manufactures, asking a premium for his father because of the father's invention of the fly shuttle.

"I have a great many more inventions than what I have given," Kay himself wrote, "and the reason that I have not put them forward is the bad treatment which I had from woolen and cotton factories in different parts of England many years ago. And then I applied to Parliament, and they would not assist me in my affairs, which obliged me to go abroad to get money to pay my debts and support my family."

With the hope of securing a reward from the government, he later returned to England, but, failing in his efforts, he again took up his residence in France, where he died in obscurity and actual want. His inventions with modifications are, however, in use to this day.

One of the improvements was made by his son Robert, who worked out the drop-box in 1760, by which many different kinds of weft could be worked into the same fabric, and figured goods thus be produced.

In fact, a strain of inventive genius seems to have run through the Kay family, for Robert, too, was constantly working upon textile inventions; and some of his inventions, in modified form, are in use to-day.

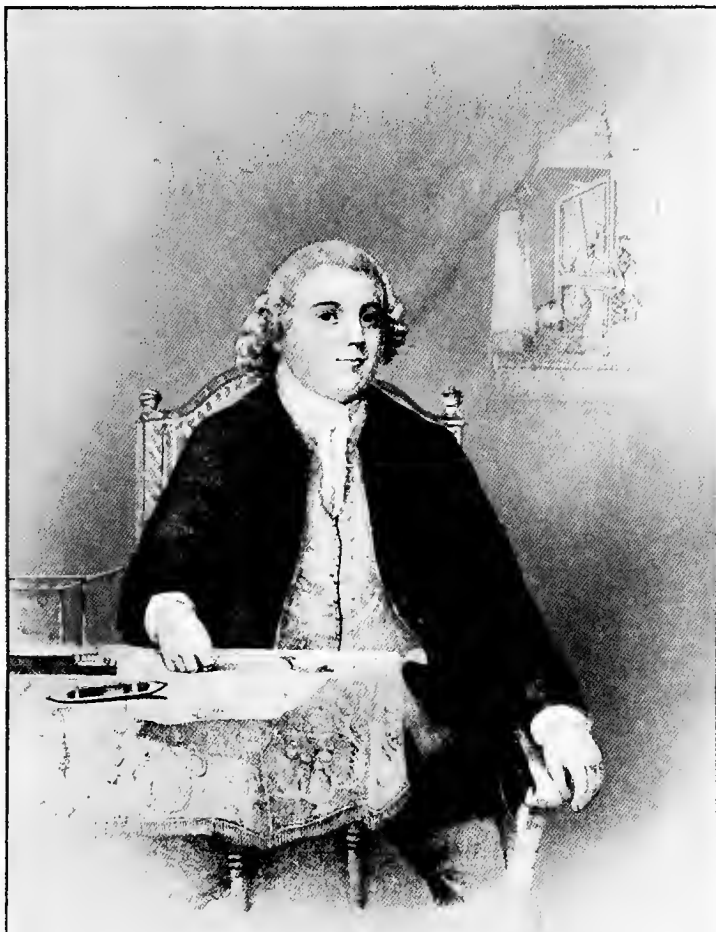

JOHN KAY OF BURY
A LANCASHIRE WORTHY

PAUL AND WYATT

Lewis Paul and John Wyatt, other early inventors about whom little is known, originated the principle of spinning by rollers, and took out their first patents June 24, 1738. The patent is thus described: "The wool or cotton being prepared, one end of the roving is put between a pair of rollers, which by their motion draw in the cotton to be spun, and a suction of other rollers moving proportionately faster than the first draws the roving into any degree of fineness which may be required." Although two cotton mills, one at Birmingham and the other on a larger scale at Northampton, were built in 1741, to operate under the patent, neither was successful. Lewis Paul took out a patent on a carding machine Aug. 30, 1748, and on June 29, 1758, he patented his spinning machinery.

JAMES HARGREAVES

The first practical improvement in spinning was the invention of the spinning jenny by James Hargreaves, a poor and ignorant spinner and weaver, who is sometimes described as a carpenter, because he probably combined the latter trade with that of his textile work. Very little is known of his early life. He was a weaver, living at Sandhill, near Blackburn, England, in 1760, and had invented a carding machine. A contemporary describes him as a "broad-set man, about five feet ten." His ingenuity seems to have attracted the notice of the Peel family, for in 1760 he aided Robert Peel, of Blackburn, founder of the family, to make a carding machine based on one that had been worked out by Lewis Paul; but it was not a success.

Hargreaves conceived of his invention by seeing a one-thread spinning wheel, which his small child had accidentally overturned, continue to revolve when the spindle was thrown into an upright position, and the thought came to him

that if a number of spindles were placed upright, side by side, a number of threads might be spun at one time. He set to work upon the idea, and in three years, June 22, 1770, patented his spinning wheel, which he named after his daughter (probably the child that had upset the original wheel), a spinning jenny, and so the invention has continued to be known. The number of spindles was originally eight, but rose to twenty or thirty, and eventually to as many as one hundred and twenty.

Owing to the awkward position that the machine required of the operator, children could more readily work it, and children, therefore, were thus early set to work at textile machines. As the spinning jenny did not make thread strong enough for the warp, and the roving still had to be spun in the old way, the use of the invention was restricted.

RICHARD ARKWRIGHT

It has long been a question of dispute to what extent Richard Arkwright used the ideas of Thomas High in the working out of the next step in spinning machinery,—the perfection of a practical roller spinner. In the suits that were brought by Arkwright to establish his patents, John Kay, the clock maker of Warrenton, who assisted Arkwright in the construction of his machinery, declared that he told Arkwright of the invention of roller spinning by Thomas High, and that Arkwright knew of High's work while he was at work upon his inventions.

However this may be, to Richard Arkwright, more than perhaps to any other Englishman, the development of the textile industry about Manchester is due, and to his undoubted mechanical genius must be attributed the completion in practical shape of roller spinning and other processes of the textile industry. He found the industry largely decentralized. His financial and executive ability, as well as his mechanical bent, gave the textile industry

in England such an impetus that the rest of the world has had quite a task to overtake it.

To him also belongs the unusual distinction, not only of revolutionizing an industry, but of compassing the social rise from a barber's chair to knighthood. It was not until his perfection of the spinning frame that warp threads of cotton could be made strong enough to meet the necessary requirements.

As described in after-life by the dyspeptic Carlyle, "He was a plain, almost gross, bag-cheeked, pot-bellied Lancashire man, with an air of painful reflection, yet also of copious, free digestion."

Arkwright was one of thirteen children, born in Preston, Lancashire, Dec. 23, 1732, of parents so poor he was early forced to work, and thus had opportunity for no more education than could be scantily acquired at an evening school. Never could he read or write with ease, and, even when more than fifty, he stole four hours daily from the scanty allotment for sleep in order to learn grammar and spelling.

He was apprenticed, when a boy, to a barber, and at the end of his apprenticeship established himself at Bolton. One of the strange tales told of this period of his life is to the effect that, while in Bolton, he occupied a cellar, over the entrance to which he put this sign: "Come to the Subterranean Barber. He shaves for a Penny." After the other barbers reduced their prices to meet the competition, Arkwright later announced, "A Clean Shave for a Half Penny."

Coming into the possession of a secret chemical process for dyeing the hair, Arkwright travelled through the country, buying hair, which he dyed and sold to wig makers at larger prices than others could obtain. His childhood at Preston, where there was a manufactory of linen from yarn spun with the distaff and spindle, had probably made him somewhat familiar with the textile industry, and

this knowledge was increased by his work as a buyer of hair in a district where spinning and weaving were common in most households.

Although Arkwright was not a practical mechanic, he had mechanical ability, which enabled him to see possibilities in machines and to direct the handiwork of others. As early as 1767 Arkwright had become interested in textile machinery, for he then employed Kay, the Warrenton clock maker, "to turn him some brass and bend him some wires." It was reported that he was trying to produce perpetual motion. Accounts differ as to what first set him to work on the spinning process.

One story is that he got his idea of roller spinning from seeing a bar of red-hot iron elongated by being drawn between two pairs of rollers, the second pair moving faster than the first. Kay says that Arkwright requested him to make a model of the machine used by High. This may or may not be true, but one thing is certain: Arkwright made practical what other men had been unable to do; and, more than that, he was able to put the machinery to such practical use that it changed the face of Lancashire and the textile industry.

Arkwright had no means of financing his manufacturing, so he returned to Preston, his birthplace, and succeeded in interesting a liquor dealer and painter named Samuel Smalley. Arkwright's machine was set up in the parlor of the house belonging to the Free Grammar School, and so convinced Mr. Smalley of its utility that Smalley offered Arkwright his time and means for the marketing of the machine.

So straitened, however, did Arkwright's financial condition become during his stay at Preston that, when the "Great Election" took place, his suit was so ragged that another was given him to vote in. He and Smalley not having the means necessary to perfect the invention, and fearing the destruction of machines in Preston by mobs



SIR RICHARD ARKWRIGHT

Rich Arkwright

of workmen similar to those that had already destroyed the spinning jennies about Blackburn, Arkwright removed his machine to Nottingham, and interested some bankers named Wright. The machines not being perfected as speedily as the bankers hoped, they withdrew, and Arkwright sought aid from Samuel Weed, of Nottingham, a partner of Jedediah Strutt, of Derby, who already had patented the stocking frame. Weed, Strutt, and Arkwright formed a partnership, and on July 3, 1769, Arkwright took out the first patent.

According to the specifications of his patent he says: "I had by great study and long application invented a new piece of machinery never before found out, practised, or used for the making of weft grown from cotton, flax, wool, etc. That part of the roller which the cotton runs through is covered with wood, the top roller with leather, and the bottom one, fluted, etc., by one pair of rollers moving quicker than the other, draws it finer for twisting which is performed by the spindles, four in number, each twisting one of the four threads delivered by the four pairs of rollers." The first cotton mill in the world, as we have seen, was erected by him at Nottingham and was operated by horses.

Arkwright's success with the spinning frame spurred him on to further inventions, and the new mill, which we have also learned was built in 1771 at Cromford and run by the river Derwent, compassed the whole operation of cotton spinning under one roof, and in this mill began the employment of children in factories.

As it was found difficult to market the excellent yarn produced by the mill, a stock soon accumulated, and, to use up the accumulation, Arkwright began in 1773 the weaving of calicoes, erecting for that purpose at Derby the first fire-proof mill ever constructed, and fitting it up with the best hand looms attainable, the power loom not yet having been invented. Further patents covering the whole

spinning process, comprising carding, drawing, and roving machines, were taken out Dec. 16, 1775, by Arkwright; and these, together with the water frame, as Arkwright's roller spinning invention was termed because of its being operated at Cromford by water, made it possible for the first time to make cotton yarn strong enough for warp, and thus did away the linen yarn generally used for the purpose.

In the mean time the spinners in different parts of Lancashire watched with considerable anxiety the increased production of the labor-saving devices which they thought threatened their livelihood, and finally, in 1779, stoned a mill that Arkwright had built in Chorley, and smashed every carding and spinning machine for miles about, sparing only spinning jennies of twenty spindles or less, because they could be worked by hand.

Infringements of his patents sprang up on all sides, but could not affect his prosperity, for his capital and mills enabled him to overcome all obstacles. He sued nine of his competitors for infringements in 1781, and at the trial of these suits the principal defendant produced as witnesses Thomas High and Kay to combat Arkwright's claims to his patent rights, and the suits resulted in 1785 in the annulment of the patents.

This lowered the bars to the industry, and the enormous profits brought unprecedented influx of capital to the whole trade. It had little effect, however, upon the prosperity of Arkwright, because the number of his mills and the amount of his capital now enabled him to meet all the competition. He had the greatest confidence in his own machinery and ability, and made light even of questions of taxation, remarking that his machines would enable him to pay the national debt.

His improvements in the textile industry attracted the favorable comment of the king, and in 1786, on the occasion of his presenting an address as the sheriff of his

county, congratulating the king on his escape from the knife of Margaret Nicholson, he was knighted. His industry was prodigious. Often he worked from five in the morning till nine at night, and, to prevent the wasting of time, he generally travelled at rapid speed with four horses to his coach. He died at Cromford, Aug. 3, 1792, leaving a fortune of almost two million dollars and an incomplete castle at Willersby, England.

SAMUEL CROMPTON

The early inventors had made practical the spinning at one time of a number of threads sufficiently strong, however, only for the weft. Arkwright worked out the water frame so that a coarse warp thread could be spun. It remained for Samuel Crompton to further perfect the spinning process by combining the Hargreaves spinning jenny and Arkwright's water frame in the machine called at first "the muslin wheel," then the "Hall-in-the-Wood wheel," and finally "the mule," because it was a "cross" between the spinning jenny and Arkwright's spinning frame. Until the invention of this machine, muslins were imported from India because Europe could not make yarn fine enough; but the muslin wheel, or mule, for the first time made it possible to spin yarn equal in fineness to the production of Hindu spinners.

Crompton, who was born Dec. 3, 1753, at Firwood, near Bolton, came of a family which, like others of Lancashire, farmed, carded, spun, and wove. The eccentricities of the family cropped out to a lesser degree in the characteristics of Crompton.

The family soon after his birth took up their residence in the portion of an ancient mansion in the woods near Bolton, called "Hall-in-the-Wood," and soon after the father died, leaving the son to be brought up by the widow and her peculiar brother-in-law, Alexander Crompton.

Crompton's mother was wont to beat him, not for any particular fault, as she told him, "but because she loved him so." When a young child, she set him to work trampling the dirt out of the washed cotton, and when he was sixteen, after receiving an ordinary education at Bolton Day School, she set him to spinning at home. In fact, he had begun to assist his mother at her loom as soon as his feet could work the treadle. She was noted for her excellent honey and elderberry wine, but she was hard and exacting, demanding a certain amount of work each day from Sammy. His uncle was so lame that he could not leave the room in which he slept at Hall-in-the-Wood. He, too, wove fustian on all days but Sunday. At the sound of the church bells he would put on his best coat and slowly read the service, concluding about the time church was dismissed. And he went through a similar ceremony at the time of the evening service.

Crompton was reserved, industrious, and studious, very fond of music, and he made a violin upon which he became so proficient that he was able to play in the orchestra of the Bolton Theatre.

The yarn being soft and constantly breaking on the Hargreaves jenny upon which he spun, his mother scolded him because he thus lost time in joining threads. His thoughts, therefore, early turned toward an improvement of the machine. It may have been that he desired more time for his violin or for his pleasures. As he attended night school and was studying mathematics, his work kept him from his books and also the violin, so that he was more and more driven to invent some improvement that would lessen the time of his work.

From 1774 to 1779, or from the ages of twenty-one to twenty-six, he was engaged upon the mule, his only leisure being after his day's work or during hours taken from sleep.

"My mind was in a continual endeavor to realize a more

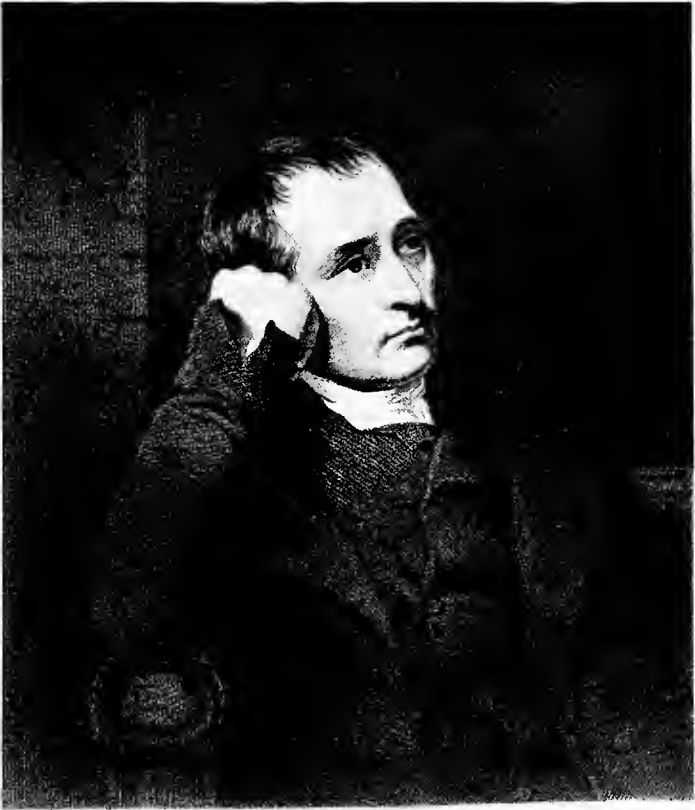

SAMUEL CROMPTON

Saml Crompton

perfect principle of spinning," said he, "and, though often baffled, I as often renewed the attempt, and at last succeeded to my utmost desire at the expense of every shilling I had in the world."

All his spare cash and more had gone for tools and materials, and, when the Bolton Theatre opened, he was glad to earn eighteen pence a night, playing the violin in the orchestra. He worked secretly, not even his mother and uncle knowing what he was doing until the noise of his night work aroused their curiosity. The lights and strange noises at unusual hours, heard by the neighbors, soon made them think that the hall was haunted, and their curiosity finally became so great that they would climb up to his attic windows to watch his work.

His first mule was made of wood and iron secured from a near-by smithy, and the point of his invention was that his spindle carriage was so adjusted that the thread had no strain upon it until it was completed. As it was described, "The carriage with the spindle could by a movement of the hand and knee recede just as the rollers delivered out the elongated thread in a soft state, so that it would allow of a considerable stretch before the thread had to encounter the strain of winding on the spindle."

"How did Crompton make that yarn?" was the universal question of the buyers of yarn in the market-place, who were surprised by the fineness of his thread.

It became possible at once to make East India muslins at home, and Crompton's prosperity began. He married, and hired a cottage near the Hall, continuing to weave and to retain his work-room in the Hall. Orders for his yarn at his own price poured in on him, and great was the desire to know how he spun. All kinds of plans were used to ascertain it. Some climbed to the windows of the work-room, and peeped in, so that he was obliged to set up a screen to hide his machine, and one of the manufacturing neighbors even climbed into the loft over Crompton's

workshop, and watched him for several days through a gimlet hole he had cut in the ceiling.

When Blackburn spinners commenced smashing Hargreaves's jennies, Crompton took his machine apart, and hid it in a loft near a clock in the Hall. He realized, as he had no money for a patent, that he must either destroy his machine or make it public. He therefore set about raising a subscription as a reward for making known to the manufacturers his improvements in spinning, and secured fifty-five subscriptions of one guinea each and sixty-seven of six shillings and sixpence, less than the cost of one mule. He realized scarcely anything from this, however, as most of the subscribers failed to meet their subscriptions.

Removing to Oldham, he continued to farm and spin to such perfection that his yarn was the best and finest in the market. It was thought that he must have made some improvements in his machine, and, to discover what these were, efforts were made to bribe his servants. Sir Robert Peel offered him a large salary and prospective partnership, which he refused. Gentlemen of Manchester raised about five hundred pounds for him, which he promptly sank in the development of his business.

About 1780 he invented a carding machine which was not practical. In 1800 he rented the top story of a Bolton factory, and installed two mules and the necessary preparatory machines, but he could not keep his workmen, as others hired them as soon as he had trained them.

A grant of ten thousand pounds sterling by Parliament to Cartwright, who invented the power loom, led Crompton in 1809 to make a similar appeal. He visited all the manufacturing districts, receiving much attention at Glasgow. The manufacturers wanted to give him a dinner, but his shyness shattered the plans.

"Rather than face up," said he, "I first hid myself and then bolted from the city."

His case, however, was not laid before Parliament until later; but, as Parliament was slow to act, he wrote to Mr. Giddy, who was pushing his claim, that there would be no difficulty in getting rid of him. "The only anxiety I now feel is that Parliament may not dishonor themselves. Me they cannot dishonor. All the risk is with them. I consider it to be the greatest honor I can confer upon them to offer them an opportunity of doing me and themselves justice."

He said, further, his friends and family would be ashamed, had he come begging or demanding, as he "only wanted a fair hearing and dealing according to merit."

Spencer Perceval, the prime minister, took up the matter, and was ready to suggest that Crompton be granted twenty thousand pounds, but, before he could recommend it, he was assassinated in the House of Commons, 1809, by John Bellingham, and Crompton was allowed only five thousand pounds. He invested this in a small bleaching establishment, where he spent much time in devising new patterns for fancy muslins, which his neighbors stole, and undersold him by manufacturing cheaper fabrics.

So prosperous became the weaving fraternity through the invention of the mule that it was the practice of Manchester weavers to walk the streets with five-pound notes stuck in their hat-bands, smoking long church-warden pipes; and they would allow no other handicraft men in the rooms which they happened to be occupying in the public house. By 1812 4,600,000 spindles were at work on mules using 40,000,000 pounds of cotton annually, and employing 500,000 operatives.

Crompton was a man of much sensitiveness. He believed in spiritualism and witchcraft, and was an excellent musician. He had physical strength and much personal beauty. One of his feats was to take a sack of flour by the end and toss it on to a cart. He is described as wearing corduroy breeches, woolen stockings, dark gray or black

coat, colored neck-cloth, and always a clean shirt and clean shoes. If any one on the Manchester Exchange ventured to offer him lower than he asked for his yarn, he would wrap up his samples and refuse to show them again. Once, when a foreign count called at Bolton to see him, he sent back word that he could not be seen, as he had gone to bed. The friend replied that the count would then visit him in his bedroom, to which Crompton answered that, if he did, he would hide under the bed.

He was not a success as a business man. In 1824 some friends helped him out with an annuity of sixty-three pounds, while in 1826 another attempt was made to secure aid from Parliament. He finally died, June 26, 1827, at Bolton.

EDMUND CARTWRIGHT

These improvements of the spinning machines so increased the output of yarn that there was almost a glut of the market, and more and more imperative grew the demands for a loom that would handle the production on a greater scale, as the old hand loom proved so totally inadequate.

The problem of the power loom, therefore, received consideration in many quarters. The one who succeeded in working out a practical plan for power weaving, and who did for the old hand loom what Paul, Wyatt, High, Arkwright, and Crompton had done for the spinning machine, was Edmund Cartwright, a minister of the Church of England.

He knew little about mechanics when a chance conversation in a public house directed his attention to the problem of power weaving. As Cartwright himself described it, "Happening to be at Matlock in the summer of 1784, I fell in company with some gentlemen of Manchester, when the conversation turned on Arkwright's spinning machinery. One of the company observed that, as soon as



D^r CARTWRIGHT

Arkwright's patent expired, so many mills would be erected, and so much cotton spun, that hands never could be found to weave it. To this observation I replied that Arkwright must then set his wits to work and invent a weaving mill. This brought on a conversation on the subject, in which the Manchester gentlemen unanimously agreed that the thing was impracticable; and in defence of their opinion they adduced arguments which I certainly was incompetent to answer, or even to comprehend, being totally ignorant of the subject, having never at any time seen a person weave. I controverted, however, the impracticability of the thing by remarking that there had lately been exhibited in London an automaton figure which played at chess.

"Some time afterwards a particular circumstance recalling this conversation to my mind, it struck me that, as in plain weaving according to the conception I then had of the business, there could be only three movements which were to follow each other in succession, there would be little difficulty in producing and repeating them. Full of these ideas, I immediately employed a carpenter and smithy to carry them into effect. As soon as the machine was finished, I got a weaver to put in the warp, which was of such material as sail cloth is usually made of. To my great delight, a piece of cloth, such as it was, was the production.

"As I had never before turned my thoughts to anything mechanical, either in theory or practice, nor had even seen a loom at work, or knew anything of its construction, you will readily suppose that my first loom must have been a most rude piece of machinery. The warp was placed perpendicularly, the reed fell with a force of at least half a hundred weight, and the springs which threw the shuttle were strong enough to have thrown a Congreve rocket. In short, it required the strength of two powerful men to work the machine at a slow rate, and only for a short time.

Conceiving in my great simplicity that I had accomplished all that was required, I then secured what I thought a most valuable property by a patent, April 4, 1785. This being done, I then condescended to see how other people wove; and you will guess my astonishment when I compared their easy mode of operation with mine. Availing myself, however, of what I then saw, I made a loom, in its general principles, nearly as they are now made; but it was not till the year 1787 that I completed my invention, when I took my last weaving patent, August 1st of that year."

Cartwright had thus accomplished what had seemed to be impossible,—he had made a loom which could be automatically stopped upon the breaking of a thread, and which made practical the production of fabrics by power machinery.

That Cartwright, a complete stranger to the textile industry, should have been able to accomplish what mechanical geniuses in the industry itself had worked in vain to attain is but another illustration of the truth which crops out so repeatedly in the history of invention, and even in the merchandising of goods,—that some of the most remarkable inventions have sprung from, been evolved and worked out by, men who, when they first conceived of an improvement in the required machine, were strangers to the occupation which the invention benefited. It is also true of business that some of the most successful plans of merchandising or of marketing goods have come from a man who was not engaged in the business that the idea helped.

Edmund Cartwright was born at Nottingham, April 24, 1743, and was the fourth son of William Cartwright, who came of an established family. Cartwright was educated at the Wakefield Grammar School, and was particularly proficient in mathematics. He entered Oxford at fourteen years of age. Here literature attracted his

attention, and he wrote verses and book reviews for the *Monthly Review*. He married, settled in the rectory of Goodby, Marwood, Leicestershire, and later obtained a prebend in the cathedral of Lincoln. He devoted himself to his calling and literature. He had already published "The Armine and Elvira," a legendary poem, and also "The Prince of Peace."

As described by his friend Crabbe, the poet, "Few persons could tell a good story so well, no man make more of a trite one. I can just remember him, the portly, dignified, old gentleman of the last generation, grave and polite, but full of humor and spirit."

The manufacturers to whom he showed his loom gave him little encouragement, and finally, in order to bring out his invention, he set up a factory of his own at Doncaster, a bull at first supplying the power, which was replaced by a steam-engine in 1789. In the same year he took out a patent for a wool-combing machine. In 1792 he invented a machine for making rope. The enterprise at Doncaster failed of success because of Cartwright's ignorance of business details and the malicious jealousy of other manufacturers, who were now beginning to realize the value of his inventions.

He had already in 1786 commenced improvements on the steam-engine, patents for which he took out in 1797, alcohol being used for fuel. He had pronounced scruples about using other men's ideas, and therefore did not look at other inventions of engines, lest he unconsciously borrow an idea. For this reason his work was quite original. It is said that he assisted Fulton in his steamboat experiments. The main bent of his inventive mind was constantly at work upon textile problems, and his idea bore further fruit in the invention, in 1789, of a machine which was even more original than the power loom.

The prejudice shown by the spinners and weavers against inventions turned toward Cartwright in 1790, when a mill

which had been erected by Messrs. Grimshaw, of Manchester, and which contained four hundred of Cartwright's looms and was operated by steam, was set on fire and burned to the ground by the working-people. This was such a blow to Cartwright's purse and spirits, as other manufacturers failed to install his machines, that soon after he gave up his Doncaster mill, and became a member of the Society for the Encouragement of Arts and Manufactures.

As has been the experience of other manufacturers, he, too, was obliged to wage suits in protection of his patents, and finally, discouraged, turned his attention to the invention of agricultural implements, inventing in 1803, while in charge of the Duke of Bedford's experimental farm, a three-furrow plough and other improvements. At last he attracted the attention of the government, which in 1809 granted him a reward of ten thousand pounds with which he bought a farm at Hollonden, Kent. Here he lived until his death, Oct. 30, 1823, making implements and improvements in agricultural methods.

INVENTIONS OF KNITTING MACHINES

It is supposed that knitting was known to the ancients, although there is no direct evidence, the first historic mention being about the time of Henry IV. of England. In ancient times the leg was generally left uncovered, and, when stockings were first worn, they were cut with scissors from cloth of linen, woolen, or silk, and sewed together. Knitting probably began at an early date in the history of England, for woven woolen caps were worn by the peasants of England and Scotland as far back as the Norman conquest; and knitted caps came into general use among the poorer classes in England some time prior to 1488.

The price was then fixed by an act of Henry VII. at

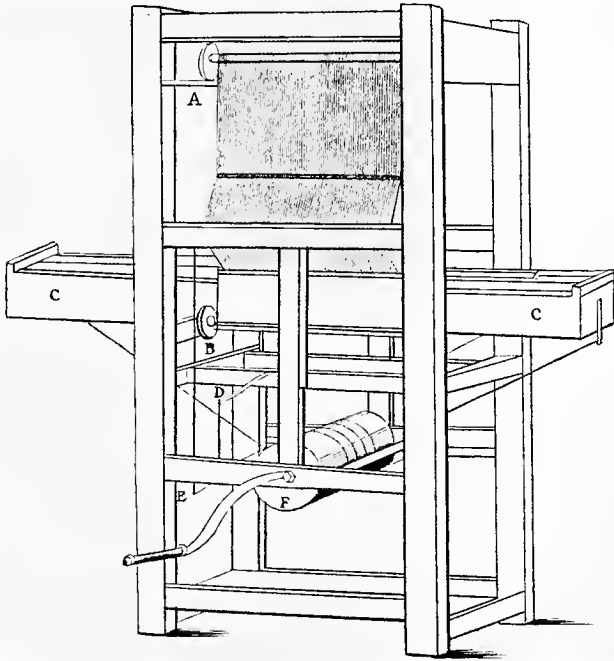

CARTWRIGHT'S LOOM

(According to the Patent Specifications, April 4, 1785)

A, the warp beam; B, the cloth beam; C, the boxes containing the springs that throw the shuttles; D, a lever having a corresponding one on the opposite side for elevating the reed, or comb; E, a lever having a corresponding one on the opposite side for reversing the threads; F, the cylinder which gives motion to the levers.

N.B.—The warp is kept to a due degree of tension by the counteraction of either a weight or spring. The web is made to wind by the like power, though in an inferior degree, and is prevented as the strike of the reed, or comb, brings it down from unwinding by a ratch and click.

two shillings, eightpence. By 1530 the word "knit" was a common term in England, and there are many references to the knitting of bonnets and hose, and the practice of knitting soon became a domestic employment.

The first attempt to knit stockings by machinery is supposed to have been made by the Rev. William Lee, of St. John's College, Cambridge, who was born at Woodborough, near Nottingham, and completed his invention before the beginning of the seventeenth century. As one story goes, Lee was deeply in love with a young townswoman of his, but, whenever he courted her, she seemed more interested in her knitting than in the attention of her suitor. This piqued Mr. Lee, and he determined to make a machine that would turn out work enough so that hand knitting would be a profitless employment, accomplishing his design about 1589. He taught his relatives to work under him, and for some time carried on his work at Calverton, England. Oliver Cromwell investigated the machine-wrought hosiery trade, and granted it a charter June 13, 1657.

It is said that Lee's invention was brought to the attention of Queen Elizabeth, who, while she expressed her admiration for the ingenuity of the inventor, was much disappointed because, instead of the fine silk hose she had expected, the output was coarse worsted stockings which had only eight needles, or wales, to the inch width. A patent was sought for Lee from Queen Elizabeth by her kinsman, Lord Hunsdon, but, in refusing the request, she said:—

"My lord, I have too much love for my poor people who obtain their bread by the employment of knitting to give my money to forward an invention that will tend to lead to their ruin, by depriving them of employment and thus make them beggars. Had Mr. Lee made a machine that would have made silk stockings, I should, I think, have been somewhat justified in granting him a patent for that

monopoly, which would have affected only a small number of my subjects, but to enjoy the exclusive privilege of making stockings for the whole of my subjects is too important to be granted to any individual."

And no patent was ever granted Lee. Spurred by the queen's remarks, however, Lee set about constructing a machine for making silk stockings, and, aided by his brother James, succeeded in 1598 in making a machine on which he was able to produce a pair of stockings which he presented to Queen Elizabeth, who was greatly pleased with their beauty and elasticity. They brought him, however, no money or patent. Discouraged and disappointed, he accepted an invitation from Henry IV. of France to establish himself in that country, and was presented by Sully to the French king. The assassination of King Henry, however, by Ravallac, while Lee was waiting at Paris for a grant of privilege to manufacture at Rouen, ended Lee's prospects, and he returned to Paris, where he died in want in 1610.

His machines were brought back to England by his brother, who established the industry there. And early in the seventeenth century the trade association of the London Frame Work Knitters was formed to regulate conditions of work and prices. Knowledge of the crude stocking frame little by little leaked out of England, though for a long time England had almost an exclusive manufacture of machine-made hose. No marked improvement, however, was made until Jedediah Strutt, Arkwright's partner, became interested in the process.

Strutt was a farmer at Blackwell, and had married the sister of William Woollett, a hosier. His brother-in-law having called his attention to the stocking frame and the need of improvement so that ribbed hose could be made, Strutt, after much study, succeeded in compassing his ribbed stocking frame, and in 1758 took out his patents. He removed to Derby, and with his brother-in-law estab-

lished his well-known mills for making hosiery. When he died in 1797 at Derby, his mills were the greatest in England.

IPSWICH MILLS

The largest manufacturers of knit goods in America to-day are the Ipswich Mills of Ipswich and South Boston, Mass., and Belmont, N.H. This industry at Ipswich began in 1818, when a number of knitters from Nottingham, England, immigrated to Ipswich and established the industry which they had mastered at Nottingham. The same year the first stocking machine was imported, secreted in the hold of the ship, and packed in a cargo of salt, as there was a fine of five hundred pounds sterling for exporting stocking machinery from England. It was not brought to Ipswich until 1822, when it knit the first pair of stockings in the kitchen of a private dwelling. Other machines were secretly imported, and in 1824 Augustine Heard, a resident of Ipswich, established the industry.

The building used by Mr. Heard's company was shortly before 1868 bought by Mr. Amos A. Lawrence, and transferred to the Ipswich Mills.

The industry was a new one, the machinery crude, and the labor unskilled. And, as America did not realize that hosiery could be made in this country, women refused to buy anything with the American mark, so that the industry first travelled a far from easy road.

Mr. Lawrence in January, 1868, wrote: "I am starting up my mill at Ipswich again, which has been stopped for a few weeks. This attempt to manufacture cotton stockings by machinery, so that they can be sold at \$1.50 per dozen, has caused me to lose not less than \$100 a day for eight hundred days,—\$80,000,—yet I am not discouraged, though I feel the loss very much."

The persistency with which the pioneer mill was handled, the ingenious invention of machinery, and competition have

made it possible to place on the market stockings of better and better value at continually lower prices. The result has been that this part of our wardrobe is constantly growing less expensive.

JOSEPH MARIE CHARLES JACQUARD

The last of the great inventions which have accomplished such wonders for the textile industry was that of the Jacquard loom. It made it possible to weave into fabrics of all kinds the most intricate and beautiful designs.

Its inventor, Joseph Marie Charles Jacquard, was born July 7, 1752, at Lyons. His father was a working weaver, while his mother is said to have been a pattern maker.

Thinking that Jacquard could better develop his physical powers in the pursuit of a trade, his father gave him little or no education. When he was about twenty, his father died, leaving him a small house and hand loom, and he turned his genius to improvements in weaving. He was unsuccessful, however, and sought other occupations, working first in a plaster quarry at Bresse, near Lyons, afterwards at cutlery, type founding, and weaving in Lyons. He served during the Revolution of 1792, his son being killed while defending Lyons against the army of the Convention.

Soon after he attracted the attention of the Council of Lyons, which gave him access to an experimental loom for the development of weaving improvements in the Palace of Fine Arts, with a stipulation that he should teach scholars without charge. He was thus engaged when the Society of Arts in London offered a reward for a machine for making fishing nets. On the 2d of February, 1804, Jacquard received three thousand francs and a gold medal from the London Society for a machine which he had perfected and exhibited to the Conservatorium of Arts and Trades.

This brought him to the attention of Napoleon Bona-



faithfully Yours
Amos A. Lawrence

parte, who sent for him. He was received by Napoleon and his great minister, Carnot.

“Are you the man who can do what God Almighty cannot,—tie a knot in a taut string?” he was asked by the Emperor.

“I can do not what God cannot, but what God has taught me to do,” was the reply.

He was given a position in the Conservatorium of Arts, where he had not only an opportunity to improve his own weaving machine, but had also the chance to study the work on textile machines of Bouchon, Falcon, and Vaucanson.

Vaucanson’s machines and automatons, one of which was said to have been a duck that would waddle, quack, swim, eat, and digest food by mechanical process, surely furnished ideas to Jacquard. Afterwards in 1804 he returned to Lyons where he finished his loom. It combined the best parts of those of his predecessors, together with those of his own improvements, and was the first machine to do practical design weaving.

The Jacquard loom had ingeniously arranged weighted strings which passed over a pulley and fell into perforated cards. Each motion changed the position of these strings, and allowed some of them to go through the holes and thus draw up the warp thread so that it was skipped by the warp; while others would strike the card, and leave their strands in place to be regularly woven. In this way the weaver could pass his threads over, under, or through the warp, as the design required.

Napoleon Bonaparte in 1806 granted him an annuity of three thousand francs with the understanding that he should transfer his invention to the city of Lyons, as well as any further improvements he might make.

His experience was like that of all other great inventors,—so violent was the opposition of the weavers to the introduction of his loom that the Conseil des Prudhommes broke up his machine in the public places, and Jacquard was com-

pelled to flee to save his life. Little by little, however, the looms were adopted, and proved to be of the greatest value, establishing Lyons as the art centre of the textile industry.

Jacquard died Aug. 7, 1834, at Oullins, France, having attained the ripe old age of eighty-two, and having lived long enough to see over thirty thousand Jacquard looms in operation in the city of Lyons.

MACHINES FOR SPINNING FLAX

The inventions of Kay, Hargreaves, Arkwright, and Crompton, were principally applicable to cotton and wool, and made little improvement in the hand methods of spinning flax, because the raw flax was too brittle to stand the strain of the tension that the spinning machine could with safety put upon cotton. The impetus given, therefore, to cotton manufacture proved most disastrous to the linen industry. The demand for linen fabrics fell off, and the trade which had been the life-blood of villages and whole provinces disappeared, and to a much lesser degree took refuge in the more remote rural localities where it was able to resist the encroachments of the power loom. In these localities, such as in parts of Ireland, linen still continues to be spun and woven by hand, and the skill shown by hand spinners and hand weavers is not excelled by the most intricate machinery of to-day.

In 1725 machinery of a crude nature had been applied in Ireland to the spinning industry without success. English inventors had before this, however, set to work upon the problem of spinning flax, and the first practical machines were the inventions of John Kendrew and Thomas Porthouse, of Darlington, England, who in 1787 took out patents upon a mule, or machine, constructed upon a new principle, for spinning hemp, tow, flax, and wool. These machines, with many improvements and modifications, have led to the perfect system for spinning flax now in use.

JAMES WATT.

The progress made in textile machinery in England would have been handicapped by a lack of motive power to drive the machines, had it not been for the improvements made in the steam-engine by James Watt, the Scottish engineer. The amount of water power was limited, and the supply during the course of the year, owing to rainfall, was irregular and often inadequate. Watt's improvements in the steam-engine came at a time when England needed steam to drive the wheels of the great industry, the output of which her inventors had so greatly increased.

The steam-engine when Watt's attention was attracted to it in 1764, by being called upon to repair a model of the crude engine of Thomas Newcomen that was a part of the scientific apparatus at Glasgow College where Watt was mathematical instrument maker, was used solely to pump water from the mines at Cornwall. Watt perceived its enormous waste consumption of steam, and began an investigation to learn the cause and the remedy. This he was enabled to do quite as much by his training as by his inventive genius.

He was born at Greenock, Jan. 19, 1736. By the failure of his father, who was a small merchant, he was thrown upon his own resources, and went to London at the age of nineteen. He apprenticed himself to John Morgan, a philosophical instrument maker, but, his health breaking, he returned home, and through acquaintances in the Glasgow College he secured his position in the college.

He found that Newcomen's engine consumed enormous quantities of steam and coal because of the alternate heating and cooling of the cylinder, owing to the use of water in chilling it and its faulty construction. Watt cased the cylinder in a non-conducting material and introduced a steam jacket, or layer of steam, between the cylinder proper and an outer shell.

He took out his first patent in 1769. As he had needed

money to carry on his experiments, he had formed a partnership with Dr. John Roebuck, who had iron works at Carron. Roebuck became involved in financial difficulties, and for a number of years Watt was occupied with civil engineering which entailed canal digging and harbor dredging. In 1768 he met Mathew Boulton, head of the Soho engineering work at Birmingham. The two formed a partnership, and in 1775 applied for a renewal of Watt's patents which he received for twenty-five years.

Watt from this time on devoted himself to perfecting and developing the steam-engine. He took out a number of patents, and soon the perfected engine had driven Newcomen's from the Cornish mines. His last patent was taken out in 1784, when he had completed the steam-engine so that it was applicable to power-driving of all sorts. It was practically the engine as it has been in use to within a few years. He found it a steam-pump, slow working, cumbrous, and excessively wasteful of fuel. His patent made it economical in working, powerful, and efficient, but it was still only a steam-pump. His later inventions adapted it to driving machinery of all kinds, and made it particularly applicable to use in textile mills. He retired from business in 1800, and his business was carried on for years by his two sons and a son of Boulton. He died on the 19th of August, 1819.

By 1811 the process of making cloth had reached such perfection in England that, according to "The Book of Days," Sir John Throckmorton, of Berkshire, could wager a thousand guineas that he would at eight o'clock on a particular evening sit down to dinner in a well-woven, well-dyed, well-made suit the wool of which formed the fleece on a sheep's back at five o'clock on the same morning. Mr. Coxetter, of Greenham Mills at Newbury, was put in charge of the work.

He had at 5 A.M. on the 28th of June two South Devon sheep shorn. "The wool was washed, carded, stubbed,



Eli Whitney

roved, spun and woven; the cloth was scoured, fullered, tented, raised, sheared, dyed and dressed. The tailor was at hand and made up the finished cloth into garments, and at a quarter past six in the evening Sir John Throckmorton sat down to dinner at the head of his guests in a complete damson-colored suit that had thus been made,—winning the wager with an hour and three-quarters to spare.”

ELI WHITNEY

The improvements in spinning and weaving machinery soon brought cotton manufacturing to a pass where its demand for raw material outran the supply, and ways and means for increasing the raw cotton available became a pressing necessity.

As the industry about Manchester had grown, new fields for the production of cotton were developed. The original source of supply was India, other parts of the East, and Egypt. It was indigenous, however, to the West Indies, and soon these islands became a source of supply. About 1770 West India cotton was transplanted to Georgia and later to North and South Carolina and other parts of the South, and it readily took growth and large crops were raised, which materially augmented Manchester's supply.

Although the production of cotton was thus increased, the separation of the cotton from the seed and boll was slow and tedious, owing to the work being done by the hand labor of the large slave population of the South. It was largely the work of colored women, who separated the seed and cleaned the cotton from the boll with their finger-nails, and it took a negro a day to pick a pound of cotton from the boll and separate it from the entangled seed. All that could be produced in the year 1792 was 138,324 pounds.

The invention of the cotton gin, perfected in April, 1793, by Eli Whitney, a graduate of Yale, revolutionized the industry, and enabled a negro to clean five thousand

pounds of cotton a day, thereby greatly increasing the supply of American cotton. Indeed, within a few years of the invention of the gin the production had grown from the one hundred thousand and odd pounds to many millions of pounds of cotton a year, and had stimulated the cotton industry so greatly that the production of cotton goods led all others.

Whitney's early environment and training gave his mind the mechanical bent which facilitated his inventive genius. At his father's farm at Westboro, Mass., where he was born Dec. 8, 1765, being one of a family of thirteen children, there was a machine shop in which the elder Whitney made wheels of various kinds and used lathes for turning tools and chair posts. In this shop Eli, when a boy not yet in his teens, was wont to make things, and soon became quite skilful in the handling of machinery.

"What has Eli been doing?" asked his father one day, upon a return from a trip, of the woman who kept house for his motherless children, as his wife was dead.

"He has been making a fiddle," was the answer.

"Ah! I fear Eli will have to take his portion with fiddles," replied the father, but the fiddle was very well made. And such a knowledge had Eli obtained through its construction that the whole countryside was soon coming to him to mend fiddles. At another time when Whitney, the elder, was at church, the younger took his father's watch apart and successfully put it together again.

When he was only thirteen, he made the first machine for manufacturing nails, the supply of which was cut off during the Revolution by the English blockade, and for three years previous to 1781 he was engaged in supplying the large demand that sprang up.

His father desired him to go to college, but it was not until he was eighteen that he made up his mind to do it. Although skilled as a mechanic, he lacked the knowledge and the means necessary to go. Accordingly, he set about

preparing himself by working for seven dollars a month and board in the towns about Worcester, Mass., by studying at spare moments, and attending, when he could, the neighboring academy. He added also to his income by selling bonnet pins and walking-sticks.

At Yale, which he entered when twenty-three years old, he made mathematics his favorite study. When the astronomical apparatus broke down during some experiments, so expert had he become that he was able to repair it. Upon his graduation he decided to study law, and, to secure the means, obtained a position as tutor to the son of a South Carolina gentleman at eighty guineas a year. Small-pox delayed his sailing, and he fell in with the party of the widow of General Nathanael Greene, who was also waiting to sail. The father of his prospective pupil, becoming discouraged by the delay, engaged another tutor, and through the aid of Phineas Miller, another Yale graduate, Whitney obtained a position as tutor in Mrs. Greene's family at Mulberry Grove, near Savannah.

One day some gentlemen were discussing, under the live-oaks and magnolias at Mulberry Grove, the slow manner of extracting the cotton seed from the cotton boll.

"Why don't you go to work and get something which will do it?" it is said Mrs. Greene exclaimed.

"Your good husband, though he cleaned the red-coats out of Georgia, could not clean the seeds from the cotton," was the retort.

"Apply to my young friend here," answered Mrs. Greene, referring to Whitney. "He can make anything. He has repaired my children's toys. My tambour frame was all out of kilter, and I could not embroider with it at all, because it pulled and tore the threads so badly. Mr. Whitney noticed this, took it out on the porch, tinkered with it a little, and—there, see what he has done with it,—made its frame as good as new."

"As for cleaning cotton seed," Mr. Whitney is reported

to have said, "why, gentlemen, I shouldn't know the seed if I saw it. I don't think I ever saw cotton or cotton seed in my life."

The next day he made it a point to see some cotton, and then set to work on a machine to pick it, Mrs. Greene giving him a room in which he could secretly carry on his experiments.

He had observed old negro mammies clawing the seed off with their nails, and with this idea in his mind he set to work on a cylinder covered with the teeth of a wire comb. He placed the rollers with the teeth so near the cotton, which projected from an upper hopper of iron mesh, that the teeth would claw away the loose fibres from the cotton bolls. Caught by the saw-like teeth, the fibre dropped the seeds through the openings of the gratings of the hopper which held the cotton. The brushes of the second roller travelled in an opposite direction, so as to remove the cotton from the first cylinder.

The invention was completed some time in April, 1793, for in November, 1793, Whitney wrote Thomas Jefferson, then Secretary of State: "Within about ten days after my first conception of the plan, I made a small, though imperfect model. Experiments with this encouraged me to make one on a larger scale; but the extreme difficulty of procuring workmen and proper materials in Georgia prevented my completing the larger one until some time in April last."

The attention of the South was at once aroused. Crowds that were denied admission to the invention until it was patented broke open the house in which it was, carried away the model, and reproduced it, so that thousands of planters commenced using it without even as much as "by your leave" to Whitney. And even associations arose to protect users against Whitney's prosecution. As there seemed to be little chance of manufacturing in the South, Whitney returned to New Haven, and commenced

the manufacture with Phineas Miller, who May 27, 1793, had entered partnership with him. The planters of the South showed no intention of admitting Whitney's right to his invention, and for a number of years Whitney and Miller sought in vain to secure returns for their work.

A formidable obstacle was the belief by English mill owners that the cotton gin ruined the cotton fibre by making it too brittle, and it was with great difficulty that this belief was overcome. It was not until after 1800 that Whitney was able to obtain a recognition from the Southern planters of his rights, and finally he secured a grant of fifty thousand dollars.

North Carolina and Tennessee both fixed a tax of two shillings, sixpence, on every saw for ginning cotton for five years, the annual collection being paid to Whitney, but the government refused to renew his patent in 1812, so that he never realized the amount to which his invention entitled him.

His partner died a disappointed man, and in 1798 Whitney turned his attention to the manufacture of firearms, establishing a plant for the purpose of making a lathe and all the necessary machinery on the shores of Lake Whitney. The government encouraged him with an order for ten thousand muskets and advanced him twenty thousand dollars. It was not until 1817 that Whitney saw the end of his financial troubles. He married the youngest daughter of Judge Edwards, of the United States Circuit Court, who was a direct descendant of Jonathan Edwards, and died in New Haven, at the age of sixty years, on Jan. 8, 1825.

IMPROVEMENTS OF THE BASIC MACHINES, AND FURTHER INVENTIONS.

Cartwright's loom was the last of the basic inventions which wrought such a change in the textile industry. Most of the machinery used in the textile mills to-day involves

the principles of these early inventions, though many of the details have been improved and modified and additional parts have been added that have greatly increased the labor saving as well as the productive capacity of the machines.

Owing to the opposition of the English workmen who thought that invention would deprive them of their livelihood and also the necessity of stopping the loom to dress the warp, it was some years before Cartwright's loom was put into much use. The best authorities are of the opinion that power looms were adopted at first more rapidly in Scotland than in England, because in 1811 they were in use in Scotland; while it is quite certain that in 1813 power looms had not been much adopted in England.

In 1794 a power loom was invented by John Bell, of Glasgow, which was soon abandoned, and June 6, 1796, Robert Miller, of the same city, took out a patent for another loom, which John Monteith adopted in 1801, and equipped a mill at Glasgow with two hundred looms. Still another loom was invented by Mr. Toad, of Bolton, in 1803. The loom which William Horrocks, of Stockport, England, patented in 1803, 1805, and improved in 1813, was the first to come into general use, and was known as the crank, or Scotch, loom. It was probably the kind that Francis C. Lowell, of Boston, saw, and which led to his working out later the first practical loom in America, the story of which is told later. As early as 1806 T. M. Mussey had built a loom at Exeter, N.H., which would weave, but was not practical commercially.

The dressing machine, out of which grew the dandy loom, that was necessary to the economical operation of the loom, was worked out by Thomas Johnson, of Bredbury, an ingenious weaver in the employ of Messrs. Radcliffe and Ross, of Stockport, England. William Radcliffe, who was alarmed by the exportation of cotton yarn, conceived that the only way to prevent the exportation



DISTAFF SPINNING
(From an old sketch)

was for the English to excel in weaving. He finally, on Jan. 2, 1802, called about him a number of his workmen, among whom was Thomas Johnson, an ingenious but dissipated young man, and explained to them his needs. So versatile were Johnson's expedients to compass the required invention that his fellow-workmen called him the conjurer. Johnson's ability and Radcliffe's perseverance produced the ingenious dandy loom, by which the warp could be dressed before it was put on the loom, and provided for the taking up of the cloth and drawing forward of the warp, so that the loom did not have to be stopped for the cloth to be moved on. The warp was thus brought within play of the shuttle.

Radcliffe and his partner, Ross, in 1803 and 1804 took out patents for taking up the cloth by motion of the lathe, and also for new methods of warping and dressing. The patents were taken out in the name of Johnson, their employee, who received a bonus of fifty pounds. English manufacturers were slow to take up the loom. Little by little, after Horrocks's invention, power looms were gradually adopted. In 1806 a factory for steam looms was built at Manchester, according to Guest, and soon after two others were erected at Stockport, while in 1809 a fourth was completed at West Houghton. In 1818 at Manchester and the neighborhood there were but fourteen factories, containing about two thousand looms, and in 1821 thirty-two factories, containing 5,732 looms.

It is impossible to more than briefly indicate the other improvements since the day of Crompton. The later improvements and many of the most essential modifications have been the work of American inventors, who with true Yankee ingenuity took the basic English machines, eliminated their weak points and strengthened their good ones, adding a part here and a part there, until the automatic power loom, as finally worked out in the Northrop loom under the direction of the Draper Company, became an

accomplished fact and is the last word in the history of textile machinery.

James Davenport, an American mechanic, received, Feb. 14, 1794, on his carding and spinning machines the first patent in the United States for any kind of textile machinery. He established at the Globe Mills, at the north end of Second Street, Philadelphia, one of the earliest manufactories for weaving flax, hemp, and tow by water power. The labor was supplied by boys, who were able to spin in a day of ten hours 290 feet of flax or hemp, and one boy could deliver fifteen to twenty yards of sail cloth a day.

Davenport went in 1797 to Boston to sell machinery, but was not successful, and died soon afterwards. The Globe machinery was sold in such small lots it was impossible to put it together again. The looms said to have been used preceded, it is claimed, by many years any other efforts to turn out a practical power loom.

One of the most important improvements worked out in this country is that of the Compound Gear, by which Mr. Asa Arnold, of Rhode Island, succeeded in combining the train of three bevel wheels so as to regulate the variable velocity needed for winding the filaments of cotton on the bobbin of the roving frame. Although the invention was put in operation in 1822, the patent was not taken out until Jan. 21, 1823. A model of this invention was taken to Manchester in 1825, and an Englishman, Henry Houldsworth, Jr., appropriated it, taking out his own English patent for the English Equation Box. It was not known for some time that Arnold was the real inventor, and he did not, therefore, secure the pecuniary advantage that should have been his.

The Danforth, or cap, spinner was the invention of Charles Danforth, of Paterson, N.J., and he secured patents Sept. 2, 1828. Here, again, an Englishman, John Hutchinson, of Liverpool, appropriated the idea in 1830 by patent-

ing it, and the invention came into wide use in England and Europe, particularly for spinning the weft, or filling, before the later improvements in the self-acting mule. The Taunton speeder, so called from its place of origin in Massachusetts, was the work of George Danforth, of Massachusetts. This, which was also known as the tube frame, was patented Sept. 2, 1824. English patents for the same thing were taken out for a Mr. Dyer, of Manchester, in 1825. The Taunton speeder was adopted to a considerable extent in England in place of the fly frame.

Gilbert Brewster, of Poughkeepsie, N.Y., invented another roving frame in 1829, in which a temporary twist was given to the roving during the passage from rolls to spools by passing the roving between two leather bands, or belts, moving in opposite directions. This was known as the Eclipse Speeder, and was used for some time because of the small cost of the machine and the large amount of work it could produce. It gave place to the roving frame with the "equation box" or "compound" movement, either in the form of the "fly frame" or "speeder," the latter name being applied to those frames in which the arms of the flier are connected at the bottom and are independent of the spindle. This, too, was introduced into Manchester with great success in 1835, and there was known as the Eclipse Roving Machine.

In 1829 Addison and Stevens, of New York, took out a patent for a traveller, or wire loop, sliding around on a single ring, and from this the present form of ring spinning has been derived and has been adopted by all large makers. To America was also due the invention of the plate speeder. The stop-motion in the drawing-frame was invented by Samuel Batchelder in 1832. By its loss of time was prevented by stopping the machine to fix breakage of the thread, and the speed of the machines could be greatly increased. No patent was taken out for it in this country, but the inventor derived some benefit from one taken

out in England by Henry Houldsworth. The ring spinner was worked out by John Sharp, of Providence, in 1831, and with later improvements came into extensive use.

To Mr. Paul Moody, who, we shall later learn, was one of those that helped to start the first complete cotton mill in America, is due the distinction of the introduction at Lowell in 1826 of the use of leather belts in place of iron gears for transmitting motion to the main shafting of a mill.

Other improvements have from time to time been added to the textile machines. The last of importance was that of the Northrop loom. The problem of an automatic shuttle changer had long engaged the attention of George Draper & Sons, the predecessors of the Draper Company, of Hopedale, Mass. In July, 1888, one of the firm investigated an automatic shuttle changer at Providence, R.I. Concluding that it was not practical, the firm set aside ten thousand dollars, and started an inventor, Mr. Alonzo E. Rhoades, on the task of devising a practical shuttle-changing loom. Mr. Rhoades by Feb. 28, 1889, had a loom ready for operation. A few years prior to this time Mr. James H. Northrop, an expert English mechanic, had come to this country and had secured work at Hopedale. He invented the Northrop spooler guide and other improvements in cotton machinery, but later left this employment to become a farmer. As farming was not congenial, he again entered the Drapers' employ and noting the work on the Rhoades machine, remarked one day in February, 1889, that, if given a chance, he could put a shuttle changer on a loom in one week's time that would not cost over a dollar. On March 5, he showed, set up in the hen-house at his farm, a rough wooden model of his idea. This so pleased the Drapers that Mr. Northrop was set to work on his idea, and by July 5, 1889, he had completed a loom, and on October 24 of the same year a Northrop loom was in operation at the Seaconnet Mill in Fall River; and by

April, 1890, several filling changing looms of the same kind were at work in Seaconnet Mill. It was soon found, however, that the ordinary plain looms were not sufficiently uniform to be adaptable for the new attachments, and the Drapers set about designing a new loom that would incorporate a warp stop-motion with the filling-changer. This entailed several years' delay, so that it was not until early in 1895 that complete Northrop looms were started in mills of customers.

The Northrop loom is said to be the first commercial loom to supply filling automatically; the first loom to automatically supply a bobbin or cop skewer to a shuttle and automatically thread the same, either commercially or experimentally; the first loom to incorporate a practical warp stop-motion for general weaving application; and the first loom to automatically supply itself with filling before exhaustion of the running supply. As a whole, it is the first to do away with the right and left hand system, and the first to generally adopt the high roll take-up.

BLEACHING

The use of machinery in the manufacturing of textiles had an immediate effect upon bringing about improvements in bleaching, dyeing, and printing. The old and slow methods used in these chemical processes could not keep pace with the increased output of goods turned out by the new methods of manufacturing, but soon improvements in the process of bleaching, dyeing, and printing enabled this branch of textile making to meet the output of the manufacturing processes. The agents by which the improvements were effected were powerful chemicals, and the use of cylinder printing in place of the old hand block method which was so long in use.

The Chinese and Hindus understood bleaching, and through the Arabs and Phœnicians it was passed on to the

Egyptians. For centuries the Phœnicians were famous for their purple dyes, and the tombs of the Egyptians attest the knowledge which they had not only of bleaching, but of dyeing and printing. According to Pliny different plants and ashes of plants were used as cleansers. The East and Egypt passed the knowledge on to the Greeks and Romans, though of their processes little is known, as the records of their skill in this respect were lost when the barbarian hordes in the early centuries of the Christian era overran the Roman Empire and Europe.

It is impossible to see just where the industry first developed in Europe, for it is probable that in Germany, Holland, and France it was known at a very early date. The Dutch, prior to the seventeenth century, had a monopoly of bleaching; and Haarlem was a great bleaching centre. Brown linen made in Scotland was sent in March to Holland to bleach, and returned about the end of October.

Bleaching had begun in England prior to the beginning of the sixteenth century. At Southwark, near London, there was a bleachery about 1650. Shakespeare speaks of the "whiting time" or "bleaching period," and those described in the process were called "whitsters." The old method of bleaching was using first sour milk and cows' dung, then steeping the linen in waste lye and for a week pouring boiling hot potash lye over it. In some parts of India the acid of lemons was used instead of sour milk, and in other parts buffaloes' milk was used. The linen was then taken out and washed and put into wooden vats of buttermilk, in which under pressure the goods lay for five or six days. The linen was then spread on grass and kept wet for several months, exposed to sunshine and rain. This steeping in lyes was called bucking, while the bleaching on the grass was called crofting.

The work was carried on in the open air, principally in the summer time, and under the old method it was often from six to eight months, especially if the weather was un-

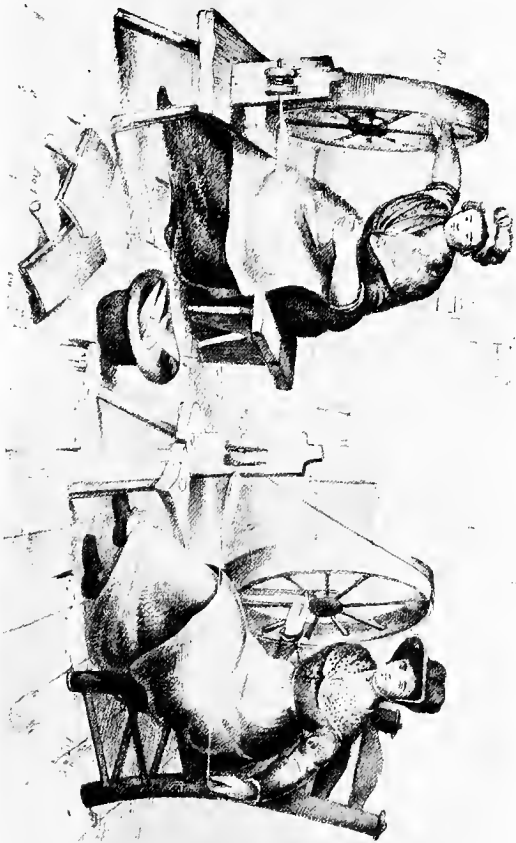

HANDICRAFT CARDING, ROVING, AND SPINNING BY THE HAND WHEEL.

(According to Richard Guest)

The cotton after being combed or carded between the hand cards (Figure 1) was scraped off them in rolls about twelve inches long and three-quarters of an inch in diameter. These rolls, called cardings, were drawn out into rovings on the hand wheel. In Figure 2 the cardings are represented lying across the knee of the rover. From the spindle of Figure 2 the rovings were taken to Figure 3, to be spun into weft. In Figure 3 the roving lies in the lap of the spinner. On the spindle of Figure 3 the weft was finally prepared for the weaver. In roving, the cardings were drawn out in an angle of forty or forty-five degrees from the point of the spindle. In spinning, the rovings were drawn out nearly in a right angle. The hand wheel was first used in the woolen manufacture.

favorable, before the bleaching was completed. The custom of outdoor exposure gave rise in England, and in parts of the Continent, to much stealing of the linen thus exposed, and stringent laws to prevent it were passed from time to time.

An enactment of George II. reads, "Every person who shall by day or night feloniously steal any linen, fustian, calico, or cotton cloth; or cloth worked, woven, or made of any cotton or linen yarn mixed; or any linen or cotton tape, inkle, filleting, laces, or any fabric laid to be printed, whitened, crofted, bowked, or dried, to the value of ten shillings, or shall knowingly buy or receive any such wares stolen, shall be guilty of felony without benefit of clergy," which was punishable by death. In Switzerland, in order to prevent the material from being stolen, they still go so far as to protect it at night with dogs, whose small houses are placed here and there about the bleaching-yard.

The final step of exposing linen to the sun and rain is still practised in Holland, Ireland, and Switzerland and other parts of the Continent, where the spinning of flax and the making of the best linen is yet a handicraft. No chemical process has yet been found that will bring about the purity of whiteness obtained by the natural methods of exposure.

Scotland early gave its attention to bleaching. In 1728, in response to the proposal of James Adair, of Belfast, to the Scottish Board of Manufacturers, a bleaching-field was established in Galloway, and a premium of two thousand pounds for the establishment of other bleaching-fields throughout the country was granted. In 1732 a method of bleaching with kelp was introduced by R. Holden from Ireland, and a bleaching-field was set out near Dundee, which used the process.

An improvement in the souring of cloth was made by Dr. Francis Home, of Edinburgh, to whom the Board of Trustees of the Board of Manufacturers paid one hundred

pounds for his experiments in bleaching. This was the discovery that sulphuric acid could be used to great advantage, instead of sour milk, in the acidulating of the water. It accomplished the souring in a few hours, while the old method occupied days and weeks. Although sulphuric acid worked admirably, bleachers were afraid of the corrosive effects of this souring process, and for some time in Ireland it was against the law to use it, although in 1774 Dr. James Ferguson, of Belfast, had received a premium of three hundred pounds from the Irish Linen Board for the application of lime in bleaching linen.

The greatest improvement in the process was the discovery in 1774 by C. W. Scheele, the Swedish chemist, that chlorine destroyed vegetable colors. This discovery was due to his accidental observation of the bleaching of the cork of the bottle which contained his chlorine, a gaseous substance contained in salt. The fact attracted the attention of the French chemist, Claude Louis Berthollet, who applied chlorine with great success to the bleaching of fabrics. Berthollet read a paper before the Academy of Science in Paris, April, 1785, which was published in the *Journal de Physique*, in which he gave the result of his success in bleaching cloth.

He showed the experiments in 1786 to James Watt, the inventor, who was also a chemist and who instituted similar experiments in England. Watt used chlorine on the bleach-field of his father-in-law, Mr. Macgregor, near Glasgow in March, 1787, and this was probably the first time that the chlorine process was used in England. The process was made known by Professor Patrick Copeland, of Aberdeen, to Gordon, Barron & Co. of that city, and was used with success by them.

The first use of chlorine was attended by serious disadvantages, owing to the injurious and obnoxious odor to which the process gave rise. One of the first improvements was the use of eau de Javel, which was first used at the

Javel works near Paris. Finally, a solution of potash, one part in eight of water, until effervescence began, was used. Scheele and Berthollet had used muriatic acid and manganese in the production of chlorine. Watt used common salt, black oxide of manganese, and sulphuric acid, with which he impregnated water confined in air-tight wooden vessels lined with tar.

Unaware of the experiments that Watt had carried on, Thomas Henry, of Manchester, began experimenting with chlorine, and was so successful that in 1788 he bleached a half-yard of calico before the Manchester bleachers. So great was the impression made on the bleachers that a Mr. Ridgeway, of Horwich, near Bolton, asked to be instructed in the process, and the improvements effected by Mr. Ridgeway and his sons marked the beginning of the modern methods of bleaching in England. Mr. Henry and Mr. Tenant both used lime for depriving the liquid, which Watt used in bleaching, of its obnoxious odors, and Mr. Charles Tenant finally evolved a saturated solution of chloride of lime which worked perfectly as a bleaching agent, this removing this difficulty.

After much opposition he obtained a patent in 1799 for saturating slack lime in a dry state with chloride, and the large manufacturing of the article which he started soon brought it into extensive use. From that time on the process of bleaching has been an improvement and simplification of the old method, and primarily follows that worked out by these Englishmen. Many minor improvements have come from Germany, which, with France, has adopted many of the English and American inventions.

Wool, before bleaching, is thoroughly washed with soap and soda to remove the grease for the actual bleaching, and the wool or the scoured yarn is treated either with sulphuric acid or hydrogen of peroxide. Cotton and wool can be bleached in a very much shorter time than can linen, which requires about six weeks.

DYEING

Having accomplished the bleaching, the fabric is ready to be either dyed or printed. As a rule, wool and silk are dyed, while cotton is printed. The process of dyeing, like others of the textile industry, is prehistoric, for fugitive stains, juices of fruits, decoctions of flowers, leaves, barks, and roots, and later on the use of different kinds of earths which contained iron and aluminum by which the stains were made permanent were in use before man thought of commemorating his deeds. It was originally a home industry, being practised with more perfection in Persia, India, China, and Egypt than elsewhere at the beginning of ancient history.

It was introduced into Egypt by the Arabian and Phœnician traders. We know that the Phœnician purple was a royal color in the Biblical days and even farther back than this, for it is to be found in the earliest tombs. Pliny tells how Egypt, in the first century, carried on the process, and shows that the use of indigo was understood by the Egyptians. The Alexandrians and Phœnicians exported their dye-stuffs to Greece and Rome. But history is not clear as to what degree the Greeks and Romans understood the art of dyeing, because the barbaric hordes which overran Europe at the beginning of the Christian era destroyed the records.

At the beginning of the mediæval era the art had sprung up in Italy, and was due to the importation of Oriental products by the Venetian merchants. From Venice the art spread to Florence, for we find the Florentine Rucellai, about the thirteenth century, had rediscovered the ancient method of making purple dye from certain lichens of Asia Minor. The first European book to contain an account of the process in use in the Middle Age was published at Venice in 1429 under the title "*Mariegola dell' arte de tentori.*"

The Italians taught the process to Germany, France,

Switzerland, and Flanders; and from Flanders England secured the beginning of its knowledge, for Edward III. procured dyers from Flanders, and in 1472 incorporated the Dyers' Company in London. The discovery of America in 1492, and the early voyages of the French, Portuguese, and Spaniards to East India by way of the Cape of Good Hope, introduced new dyestuffs, and the trade in these goods was soon transferred from Italy to Spain and Portugal for the East Indian products which came by way of the Cape of Good Hope and for the American products, such as cochineal, that came from Central and South America.

With the spread of the knowledge of dyeing, the cultivation of dye-plants soon began in Europe, particularly in Holland, France, and Germany. These countries began the cultivation of dye-plants in 1507. Spaniards in 1518 began importation of red cochineal from Mexico and Peru. The Dutch chemist Drebel's discovery in 1630 of a method of dyeing wool scarlet with cochineal led to the spread of scarlet dyeing through Europe. It was carried on with much success by the Gobelin Dye Works at Paris in 1643, and at the dye works in Bow, England, in 1662.

The Royal Society of London printed in 1662 the first English account of the dyeing processes, under the title "An Apparatus to the History of the Common Practice of Dyeing to Assist Dyers." In 1672 Colbert, minister of France, published instruction in dyeing for the use of woolen manufacturers in France. The French government appointed noted French chemists to study the dyeing processes and also the problem of manufacturing, and from 1700 to 1825 many French scientists commenced work on the problem of dyeing, the most famous of these being Dufay, Hellot, Macquer, Berthollet, Board, and Chevreul.

Prussian blue was worked out in 1770; Saxony blue, or indigo extract, 1740; sulphuric acid, 1774; murexide, in 1776; picric acid, in 1788; carbonate of soda, in 1793; and bleaching powder, in 1789.

The practical side of dyeing was being worked out by a number of men who were evolving the machinery for its proper handling. These were Thomas Henry, Home, and Bancroft in England; and in France, Dambourney, Confraville, and others. The aniline process quite revolutionized methods of dyeing, and was due to the discovery in 1834 by a German chemist, Runge, who noticed that an aniline product distilled from coal tar gave a bright blue coloration under the influence of the bleaching powder.

But nothing was done until 1856, when Sir W. H. Perkins applied the discovery with success to fabrics, and soon the aniline dyes, such as magenta, aniline blue, Hoffman's violet, and others, were worked out. It was found that many of the distillations of coal-tar products, such as benzine, naphthaline, and others, yielded beautiful dyes, and little by little vegetable dyes in Europe were superseded by aniline coloring matter, so that by 1858 aniline colors were largely in use.

Graebe and Lebermann, German chemists, in 1869 secured alizarine, the coloring matter of madder root, from anthracene, the first artificial production of vegetable dyes. Artificial indigo was worked out by Basyer in 1878. Since then many coloring products have been discovered, so the aniline process has largely taken the place of vegetable matters wherever the aniline colors have been found to be permanent. The fugitive nature of aniline dyes has precluded, however, the use of some of them where fast colors have been desired.

During the evolution of the dyeing process, work was under way in the perfection of vats, boilers, and the necessary machinery for dyeing, so that by the time the dyeing process was brought to its present perfection the machinery needed for the proper distillation of dyes was at hand.

The process of dyeing has not been determined positively either as a physical or chemical process. It is based upon



PEG WARPING

(According to Richard Guest)

The threads of the warp were divided by the pegs, each alternate thread going under the centre peg, and the succeeding thread over it. This division of the threads, called the lesser, was preserved during the weaving. At the other end of the warp the threads were passed round two pegs in a similar manner.

the affinity between the fibre of the fabric and the color. Wool is very much more readily dyed than cotton, and silk occupies an intermediate position. In many instances, cotton requires the use of a metallic base to form the agent by which the dyestuff can fix itself to the cotton fabric. When once the dye has become fixed, either in wool, cotton, silk, or linen, the perfection of the process is measured by the degree to which the dye is unaffected either by light or water.

PRINTING

Textile printing originated in China and India; also was practised by the Incas of Peru, Chile, and Mexico previous to the Spanish invasion of 1519. The Chinese used engraved wooden blocks, as did also the Egyptians. To them the process of printing was made known by the Phœnicians and Arab traders.

Textile printing came into Europe in two ways,—by land and by sea. The great caravan routes through Persia and Asia Minor brought it to the southern part of Europe, while the Phœnicians brought the knowledge of the process from the Asiatic shores by way of the Cape of Good Hope. It was introduced into England in 1676 by a French refugee, who opened on the Thames at Richmond what are said to have been the first print works in England, and certainly the first print works of which we have any definite record, although printing was early carried on in France and Germany. A district about Auersburg was famous for its printing of linen. Calico printing spread more rapidly in France, Germany, Switzerland, and Austria than in England. France was noted for a long time for the excellence of its calico printing and the refinement of its designs. In 1738 calico printing was being practised in Scotland. Messrs. Clayton, of Bamberg Bridge, near Preston, established the first plant in Lancashire in 1764.

The oldest process of printing was by hand blocks. It

was originally practised in the East. In some sections it is still in use. It is a method of printing in which a number of wooden blocks of different grains are placed one upon the other, so that the grain of each block runs in a transverse direction to the grain of the upper or lower block. The design is then cut upon the face of this built-up block, each color having a separate design cut in such a way upon the built-up block that, when the printing takes place by means of the different blocks, each color will register with the next. This is the process by which the handicraft printing is still carried on in many sections.

Perrotine printing was originated by Perrot, of Rouen, in 1834. He set his blocks in machines which did automatically the printing formerly done by hand.

Engraved, or plate, printing was discovered by Bell in 1770, and resulted in the use of an engraved color plate for printing instead of wooden blocks, though wooden blocks are in use in some parts of Switzerland. The improved method of printing gave way to roller, or cylinder, printing, which was also worked out by Bell in 1785, and which is the process generally used to-day. Adam Parkinson, of Manchester, evolved a method for keeping the roller in register so that one color could be easily printed upon another, and with slight improvements this is the method by which fabrics of cotton, wool, or linen, are printed to-day.

MERCERIZING PROCESS

The Mercerizing Process, discovered in 1844 by John Mercer, a calico printer of Lancashire, England, is closely analogous to the dyeing process, though mercerizing gives either a crepon effect or the high lustre of silk. It was found by Mercer that, when a piece of bleached calico was immersed in caustic soda, it not only changed in appearance, but became stiff and translucent. Upon being washed in running water it apparently returned to its original

condition. But a more careful examination showed that the fabric was not only stronger, but the fibre had become more rounded, the central cavity smaller, and the fibre had a greater affinity for coloring matter. The process had little commercial success on account of the expense due to the cost of the caustic soda needed and also because of the shrinkage which took place in the cloth. It was revived in 1890-91 to secure a permanent crimp, or "crepon," effect on fabrics. Depouilly, a Frenchman, had improved the process in 1884, so that a crimped effect could be given to goods of wool or silk or cotton.

The process was made commercially successful by the discovery of H. A. Lowe in 1889 and 1890 of a method of giving the silk lustre. As he allowed his patents to lapse, Thomas and Prevost repatented his invention in 1895, and the public interest was thereby aroused, although the patents were annulled on the grounds of Lowe's previous patents and the wide commercial use of the process.

The mercerizing process is done in two ways. In one the cotton stretched tight is washed in caustic soda, and while still stretched is washed clean in water. After the required degree of washing has taken place, the cotton is relaxed, and it is found to have acquired a permanent lustre.

In the second method the cotton is first immersed in the caustic soda and is then removed, and, after being stretched beyond its original length, is washed until the tension lessens. In the yarn the best lustre is obtained from the two or multifold long staple fibre. Yarn is mercerized either in the hank or the warp, and in either case is stretched on rollers. When mercerized in the piece, the fabric is stretched before it has the soda bath, and is subsequently sprayed from pipes, dipped into diluted sulphuric acids, and finally washed with water. The lustre seems to be produced by the reflection of light from the lustrous surface of the bands of twisted cotton fibre.

CHAPTER V

AMERICAN INDUSTRY BEFORE THE REVOLUTION

AMERICAN INDUSTRY—EARLIEST TRACES OF THE INDUSTRY—FOSTERING LEGISLATION—FIRST CLOTH MADE AND FIRST MILL ERECTED AT ROWLEY—SLAVE TRAFFIC AND IMPORTATIONS—ENGLISH EFFORTS TO HAMPER THE INDUSTRY—FIRST WORSTED MILL—SKILL ATTAINED IN TEXTILE WORK—BOUNTIES AND MONOPOLIES TO STIMULATE THE INDUSTRY—THE SPINNING CRAZE—APPROACH OF THE REVOLUTION—IMPROVEMENTS IN ENGLISH TEXTILE MACHINERY—CONDITION OF THE MARKET IMMEDIATELY AFTER THE REVOLUTION—AMERICAN EFFORT TO SECURE ENGLISH MACHINES—ENGLAND AND COTTON—STARTING OF COTTON CULTIVATION IN THE SOUTH—ORIGIN OF SEA ISLAND COTTON AND BEGINNING OF ITS CULTIVATION IN THE SOUTH.

In America the textile industry began almost as soon as the first settlers landed. Its rapid development was due to the fact that many of the first settlers came from a part of England where a knowledge of spinning and weaving was known in every rural household, and not a few who came to New England brought spinning wheels and hand looms. The distance from the old country threw the New England settlers largely upon their own resources, and the severity of the climate necessitated the warmest clothing, so that the colonists early instituted the industry of spinning at home.

The religious persecutions which had so much to do with the settlement of the Plymouth Colony continued for twenty years, and thus kept up a constant stream of immigration to the colonies; but, when the Long Parliament in 1640 stopped these persecutions, the intercourse with the mother country not only decreased, but the importation

by the colonies, of goods, particularly textiles, diminished, and the settlers were obliged to provide for their own wants. The wool used by the settlers came from Bilboa or Malaga or was grown upon the few native sheep, the forbears of which were brought from England soon after the first settlers arrived. In all the colonies there were but one thousand sheep in 1642.

EARLIEST TRACES OF THE INDUSTRY

In 1638 spinning wheels were valued at three shillings. One of the earliest records in the Probate Court of Suffolk County of Massachusetts speaks in 1639 of four yards of home-made cloth at six shillings, twopence. We have further evidence in Peter Branch's inventory in 1639, where home-made cloth is specifically mentioned, that spinning and weaving had begun thus early. And at this early date mills for grinding grain, driven by water or wind, and which were to furnish the site for many a fulling mill and spinning or weaving establishment, dotted the lands of Plymouth, the Bay Colony, and Connecticut. Trade was opened about 1636 with the West Indies for cotton and rum, in exchange for which the Massachusetts settlers sent Indians, and later negro slaves.

One of the first ships to bring a large supply of cotton to the colonies was the "Desire" of Salem, the biggest ship of her time, which landed her cargo in 1638 at the port from which she hailed. The first ship to bring cotton to Boston was the "Trial," and she landed a cargo in Boston soon afterwards, from St. Christopher's Island of the West Indies.

Many other interesting facts relating to this period may be found among the Proceedings of the National Association of Cotton Manufacturers, compiled by its secretary.

FOSTERING LEGISLATION

The colonial legislatures soon gave the industry favorable attention, passing acts compelling the practice of spinning and weaving, directing the planting of flax and the raising of sheep, and offering bounties for the production of fabrics. The governing body of the Bay State Colony, called the General Court then as now, as early as 1640 gave a helping hand to the infant industries by passing two orders. The first was for the purpose of encouraging the manufacture of linen, and directed the towns to see what seeds were needed for the growth of flax, to learn what persons were skilful at breaking and in the use of wheels, and ordained that boys and girls be taught to spin yarn. The second order offered for a period of three years a bounty of three-pence on a shilling for linen, woolen, or cotton cloth, if spun or woven, in the first two instances of wool or linen of native growth.

The solicitude of the General Court of Massachusetts Bay for the textile industry is shown in the order dated May 13, 1640, which is thought by the best authorities to be the earliest reference in New England by the General Court to the manufacture of cloth:—

“The Court, taking into serious consideration the absolute necessity for the raising of the manufacture of linnen cloth, &c., doth declare that it is the intent of this Court that there shall bee an order settled about it, and therefore doth require the magistrats and deputies of the severall towns to acquaint the townesmen therewith, and to make inquiry what seed is in every town, what men and woomen are skillful in the braking, spinning, weaving; what means for the providing of wheeles; and to consider with those skillful in that manufacture, what course may be taken to raise the materials, and produce the manufacture, and what course may be taken for teaching the boys and girls in all townes the spinning of the yarn; and to returne

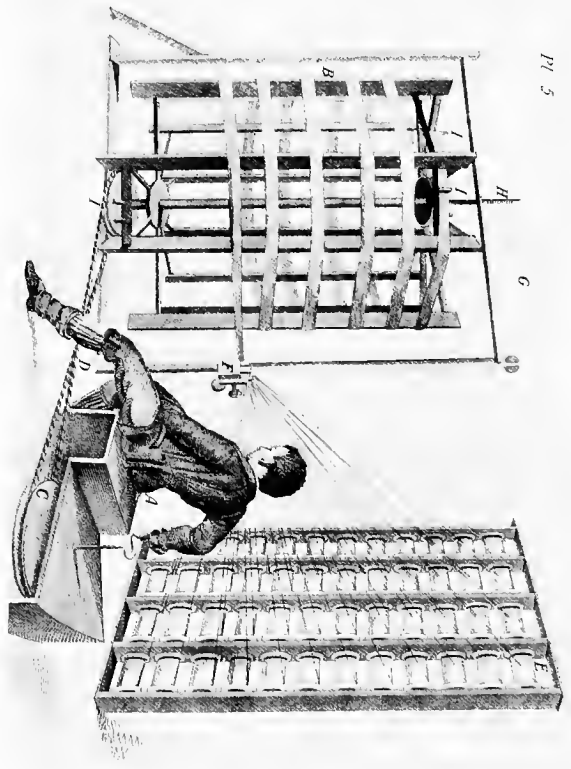

WARPING

(According to Richard Guest)

The warper sits at *A*, and turns the reel *B* by the wheel *G* and rope *D*. *E*, the yarn on bobbins; *F*, the slide, which rises and falls by the coiling or uncoiling of the cord *G* round or from the axle of the reel *H*; *III*, wooden pins similar to those used in peg warping.

to the next Court their severall and joynt advise about this thing. The like consideration would bee had for the spinning and weaveing of cotton woole."

The slowness of the importation of flax led the General Court in 1640 to recommend the gathering of wild hemp, which had been used by the Indians for rope and mat making, and twopence per pound was offered for it by many people. This native hemp had originally been brought from Connecticut by one Oldham, who claimed it was better than English hemp. Although it raised great expectations among the colonists, it failed to fill the place of English hemp, which continued to be a regular importation.

Goodman Nutt and others in 1641 received a bounty of twelvecence per yard for eighty-three and one-half yards of homespun, which was probably a coarse linen, and this is the first mention of cloth made in America. This bounty was repealed the following June. The General Assembly of Connecticut in 1641 ordered that hemp and flax should be sown by each family, and the seed preserved, "that we myght in tyme haue supply of lynnens cloath amongst ourselues"; Governor Winthrop of Massachusetts ordered that runs of stone where corn and meal could be ground be established on all available water sites; and many other steps were taken to make the colonies independent industrially of the mother country.

Shortly after came what one might call the first business panic, for John Winthrop, Jr., says that "corn in 1641 would buy nothing. Many men had gone out of the country, so that no man could pay his just debts, nor merchants make returns to England for commodities, and commerce was at its lowest." It doubtless gave a new impulse to the home industries through the necessity of supplying the colonial demand, as this financial condition of the colony practically precluded trade with England.

According to the author of "New England's First Fruits," written at Boston in 1642, "With cotton wooll (which we

have at very reasonable rates from the islands) and our linnen yarne we can make dimities and fustians for our summer cloathing; and having a matter of 1000 sheepe which prosper well, to begin withal, in a competent time we hope to have wollen cloath there made."

Home spinning impelled by the necessities of the settlers, and encouraged by the enactments of the legislature, in 1643 filled an important place in the Puritan industries, and a segregation of those engaged in the manufacture of textiles had begun, which later was to bear fruit in the great textile centres of Massachusetts.

FIRST CLOTH MADE AND FIRST MILL ERECTED AT ROWLEY

Twenty or more Yorkshire families had settled at Rowley about 1638, and to them belongs the distinction of manufacturing the first cloth in the United States, as well as erecting the first mill.

According to Edward Johnson's book, "Wonder-working Providences of Sion's Saviour in New England," published at London, 1654, "The Lord brought over the zealous-affected and judicious servant of His, Master Ezekiel Rogers, with an holy and humble people, made his progress to the northeastward and erected a town about six miles from Ipswich called Rowley. The people, being very industrious every way, soon built many houses to the number of about three score families and were the first people that set upon making cloth in this western world; for which end they built a fulling mill (1643) and caused their little ones to be very diligent in spinning cotton-woole, many of them having been clothiers in England till their zeale to promote the gospel of Christ caused them to wander."

This mill, built by John Pearson, was the first cloth mill erected in the United States. Rowley's manufactures comprised "cloath and rugs of cotton wool, and also sheeps' wool," showing that thus early cotton, which Columbus

had found was being manufactured into breeches by the natives of the West Indies, was an article of New England manufacture.

Because of the fact that nearly all of the early textile mills were located in the upper part of stone water mills, the corn being ground on the first floor, it is possible to trace back to these water rights the titles of some of the largest textile mills in New England to-day; and many of the old deeds refer to these "runs of stone" as the very beginning of their rights. The proprietors of the locks and canals on the Lowell and Merrimac Rivers maintain to this day a run of stone grinding the grist for the townspeople of Lowell. The stones are in the old grist-mill, corner of Ann and French Streets, and the old locks are near the Lowell machine-shop yard.

SLAVE TRAFFIC AND IMPORTATIONS

One of the reasons for the early commercial relations between the Leeward Islands (especially the Barbadoes, settled in 1623) and New England was that two of Governor Winthrop's sons settled in these islands, one at Barbadoes and one at Antigua. This fact, as well as the mutual needs of the two places, early led to commercial intercourse, and soon a steady trade was in progress. The importation of cotton and rum from the Barbadoes by the Puritans increased, and, when it became difficult to secure Indian slaves, the Puritans brought negro slaves from Africa, and sold them to the West Indians in place of the Indians, so that New England was not only the first to promote the merchandising of slaves in America, but later, when the heinousness of the traffic appalled the New England conscience, New England was also the first to take steps to end the traffic.

The wool used by the early mills, which came from Spain and England, was spun into yarn by the neighboring farmers,

who also raised the sheep that supplied the domestic wool. Efforts were made to raise flax and hemp, but, to meet the colonial demand, it had to be imported in considerable quantities.

The colonies all along the Atlantic coast as far south as Philadelphia, soon after their establishment, realized the necessity of extending production by manufactures which were not indigenous to the country, or the need of what is now known as protection to industry. But this phase of protection took the shape of special legislation by bounties and relief from duties. As late as May 1, 1770, the *Essex Gazette* of Salem printed the following:—

“Last Thursday the premium of four guineas on the best piece of Broad Cloth, bro’t to Edes & Gill’s Printing Office, in Boston, for sale, of 12 yards long and 7 quarters wide, was adjudged to Mr. Toby, Cambridge & Co., of Lynn, who from the 1st of June, 1769, to May 1st, 1770, have made upwards of 500 yards of Broad Cloth, and upwards of 3000 yards of narrow cloths from the 1st of June, 1769, to the 1st of April, 1770.”

The early bounties for making cloth greatly promoted the growth of the textile industry, and, though the colonial enactments were soon repealed, the industry had become so firmly established by the middle of the seventeenth century that wool was a regular article of merchandise, and statutes were passed by the Bay State colonies prescribing that it should be washed when offered for sale.

ENGLISH EFFORTS TO HAMPER THE INDUSTRY

Oliver Cromwell, the stern “protector” of England from 1653 to 1658, watched with anxious eye the effect of the colonial textile development upon England’s own industry, and soon prohibited the export of sheep’s wool and woolen yarn from England. This act, which was passed Aug. 22, 1654, for the purpose of encouraging the raising of sheep

in England as well as to prevent the exportation of wool from England, had a preamble which read as follows:—

“Whereas, this countrie is at this tyme in great straights in respect to clothing and the most likeljest way tending to our supply in that respect is the rjsing and keeping of sheepe with our iurisdiction and in detail the exporting of yews is forbidden as well as the injunction that none shall be killed until they are two years old.”

One of the results of these stringent restrictions was a marked effect on colonial sheep raising, for in 1660 a report was made by the English consul that the colonies not only had one hundred thousand sheep, but were buying wool from the Dutch. Already trade had begun with Spain for wool in exchange for New England staves and salt fish.

The Massachusetts General Court met the restriction in 1656 with enactments that ordered the commons to be cleared for sheep, rams to be inspected, and hemp and flax seed to be saved and sown. The selectmen in every town were directed to “turn women, girls, and boys towards weaving,” and officials were required “to assess each family for one or more spinners or fractional part, that every one thus assessed do after this present year 1656 spin for thirty weeks every year a pound per week of lining cotton wooling and so proportionately for halfe or quarter spinners under penalty of twelve pence for each pound short.”

Classes of five, six, and ten in number, under class teachers, were taught spinning. Already in 1655 John Pierpont and others “had sett down a bast mill or under shot where the old mill stood in Roxbury,” and the same year he was allowed to erect a fulling mill. The competition in 1660 in this infant industry had reached a condition where cloth was being cheapened by the use of inferior material, and the General Court took cognizance of it by appointing a commission that was empowered to report an ordinance against deceit in making and dressing cloth. Fulling

mills were established at Watertown in 1662, Andover in 1673, Ipswich in 1675, and Barnstable in 1687. Not only was the domestic demand for dresses of tammies and light worsted fabrics as well as that for men's clothing being met by the Bay Colony, but in 1675 wool was exported to France in return for linen, and to Spain and Portugal for wine. The proficiency of the Puritans alarmed the English textile workers, especially as the colonial export trade was beginning to make some inroads upon English exports, and in 1699 Parliament passed a law prohibiting the exportation or movement of wool either within or without the plantations. This very stringent act read in part as follows:—

“No wool, woolfells or shortlings, morlings, wool-fabrics, worsteds, Bay or woolen yarn, cloath, serge, bags, kerseys, says, frizes, druggets, shalloons or any other drapery, stuffs or woolen manufactured whatsoever, made or mixed with wool or wool flax, being the production or manufacture of any of the English plantations in America, shall be laden on any ship or vessel.” Nor could same wares be laid upon any horse or carriage to be transported to any place whatsoever.

FIRST WORSTED MILL

The first worsted mill was established in 1695 by John Cornish, a comber, dyer, weaver, and fuller of Boston. He dyed with two furnaces, used two combs, and wove with four looms. His fulling mill was detached from the rest of the plant. The spinning was done by farmers, who on market days called at the mill for the clean top wool from which the noil had been removed and brought back the spun worsted. When Cornish died, serge was in the making on his looms. He left an estate of about twelve hundred dollars. German immigrants had in 1683 and 1689 established the manufacture of hosiery in Germantown, Pa., and also the manufacture of linen.

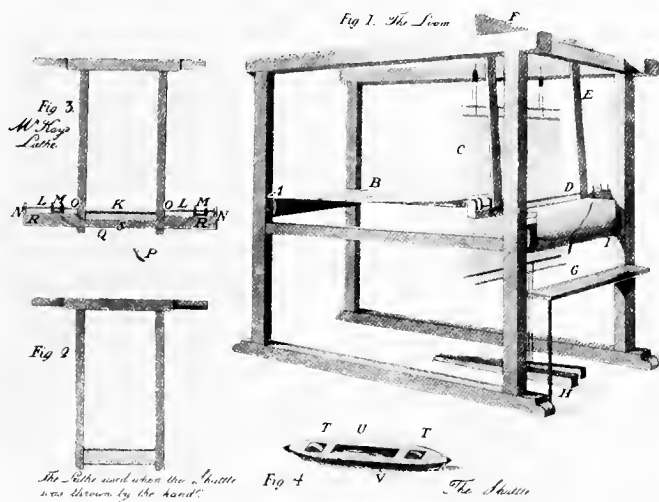

THE LOOM THAT PRECEDED THE POWER LOOM
 (According to Richard Guest)

Figure 1. The warp is wound upon the yarn beam *A*; the lesse is carefully preserved by rods *B*; one-half of the threads pass through one heald, and the other half through the other. The healds *C* are looped in the middle, and the threads of the warp go through the loops. From the healds the warp passes through the reed *D*, which is fixed in a movable frame called the lathe, *E*. A cross-piece, *F*, on the upper part of the lathe rests on each side of the loom, and the lathe swings on this cross-piece. The weaver sits on the seat *G*, and with his foot presses down one of the treadles *H*, which raises one of the healds and each alternate thread of the warp. The weaver holds the picking peg in his right hand, and with it drives the shuttle from one side of the lathe to the other, between and across the threads of the warp. The shuttle passes between the reed and the weaver, and leaves behind it a shoot of weft. By pulling the lathe towards him with his left hand, this shoot of weft is driven close to the cloth made by former casts of the shuttle. The cloth is wound upon the cloth beam *I*.

Figure 2. The lathe used when the shuttle was thrown by the hand.

Figure 3. Mr. Kay's lathe. *K*, the reed; *LL*, iron rods; *MM*, movable slides which work on the rods from *N* to *O*, and are fastened to *P*, the picking peg, by a string *Q*; *RR*, boxes, and the weaver by a sudden jerk with the picking peg moves the slide from *N* to *O*, and drives the shuttle along the sled, or shuttle race, *S*, into the box on the other side.

Figure 4. The shuttle. *TT*, wheels on which the shuttle moves along the sled. *U*, the weft, fixed in the shuttle upon a skewer. As the shuttle flies across the warp, the weft unrolls from the skewer and runs through a small hole, *V*, in the side of the shuttle.

SKILL ATTAINED IN TEXTILE WORK

There are many records to show that the colonists of New England and New York had attained considerable skill in textile work before the opening of the eighteenth century and were supplying a growing domestic demand.

According to Bishop's "History of Manufactures," America at this time was supplying quite exclusively her own demand for the stouter and coarser kinds of mixed fabrics, particularly those into which linen and hemp thread entered. Cotton, which was being imported from the Barbadoes and occasionally from Smyrna and elsewhere, was being woven with linen into fustian and other fabrics.

Linen, however, continued to be the principal material used in the manufacture of textiles, being employed at this early date where cotton would now be used. Much attention was therefore given to the planting and raising of flax and hemp which the linen manufacture called for in growing quantities. Much of the domestic linen was of a coarse texture, and was combined in various ways with wool into kerseys, linsey-woolseys, serges, and druggets. These comprised the outer clothing of most of the population in winter, while hempen cloth or linen, fine or coarse according to the station of the wearer, was the outer apparel for warm-weather wear.

The domestic industry supplied the shirts and underwear, bed and table apparel, of nearly all classes, but, as the process of manufacture was crude, the finer finish of imported fabrics was little known in America. The fabrics were serviceable rather than beautiful, and the material used was grown upon the farms, or plantations. The various steps in the preparation of the flax, such as the breaking and heckling, were performed by the men, while the lighter forms of labor, such as the carding, spinning, and often the weaving, together with the bleaching and dyeing, were delegated to wives and daughters.

All thrifty families took much pride in the abundance and quality of their linen, and everywhere about the colonies domestic linen was much in evidence. An English visitor, Lord Cornbury, said in 1705 he had seen serge made upon Long Island that any man might wear, and in 1708 he reported "they make very good linen for common use." In 1708 Caleb Heathcote wrote "that three-quarters of the linen and wool used by the Colonists was of domestic manufacture." As early as 1706 Joseph Lewis had a weaving establishment at Waterbury, Conn., and in 1718 Massachusetts laid an import duty on manufactures, and the province, according to the laws of trade, worked wool into coarse cloth, druggets, and serges. Samuel Hall in 1722 was not only making buckram cloth in Boston, but was dealing in it as a retail merchant.

In 1724 Richard Rogers, of New London, Conn., was weaving duck on eight looms. He expended one hundred and forty pounds, and in the following year increased it to two hundred and fifty pounds for enlarging his plant, and the General Court gave him a monopoly for ten years. In 1726 the Salem Court awarded Nathaniel Potter thirteen pounds and fifteen shillings for three pieces of linen manufactured at Lynn.

In most of the New England farmsteads and villages spinning wheels and looms for wool were to be found, and by 1746 spinning was an occupation in every household, rich as well as poor, while spinning festivals on the common were holiday pastimes. The great interest in spinning revived the old talk of a town school for teaching it, which finally led to the erection of a brick building for special instruction. A tax on carriages to support this industrial institution was proposed, but was abandoned soon afterward.

In the States of Massachusetts, Rhode Island, and Connecticut the textile industry had become thoroughly established, and the governing bodies were fostering it with lib-

eral bounties. The General Assembly of Rhode Island in 1722 voted William Borden, of Newport, an ancestor of the well-known Borden family of Fall River, twenty shillings for each bolt of duck made of hemp grown in the province equal to good Holland duck. The bounty was to last ten years. But it was not enough, for in response to a petition five hundred pounds was granted him May, 1725, from the colonial treasury, "if there be so much to spare."

He again asked for assistance in 1728, whereupon the Assembly issued three hundred pounds in bills of credit at his expense and loaned the amount to him without interest, with surety that it would be repaid in ten years. By the terms of the resolution he was required to make one hundred and fifty bolts every year of good merchantable duck. In 1731 the amount he should make was changed so that the bounty was granted upon any quantity. Bounties also were given to growers of flax and hemp, to encourage the making of linen. Such progress had the colonies made that by 1732 one-third of the woolens needed were of home manufacture, two-thirds being imported from England.



BOUNTIES AND MONOPOLIES TO STIMULATE THE INDUSTRY

Rhode Island was paying bounties to growers of flax as well as to manufacturers, while Massachusetts in 1726 granted a monopoly for hemp manufacturing to a petitioner and a bounty for "each piece thirty-five yards long, thirty inches wide, of good, even thread, well drove, of good, bright color, being wholly of good, strong, water-retted hemp." Nathaniel Potter in 1726 was granted thirteen pounds and fifteen shillings by the Salem Court for three pieces of linen made at Lynn. Hemp was received in 1739 at fourpence a pound for taxes, and flax for sixpence a pound. In almost every hamlet, by 1746, weaving mills might be found.

The promotion of the textile industry early in 1748 had

attracted such public interest that a movement was started in Boston not only for the promotion of manufactures, which would relieve the province from the drain of sending money to England to meet the excess of imports over exports, to develop domestic manufactures and the immigration of skilled mechanics, but also to afford employment to the poor.

Accordingly, a number of the leading citizens of Boston on March 10, 1748, in order to compass these purposes, organized and subscribed from fifty to one hundred pounds each to promote the linen manufacture. Another meeting was held on the 12th of July, 1750, which seems to have resulted only in further talk of the establishment of a linen manufactory house on the Common, and it was also proposed to open several spinning schools in the town where children might be taught free of charge.

But it seemed difficult for the industry to get a start, and finally the Society for Encouraging Industries and Employing the Poor was organized Aug. 21, 1751, under whose energetic auspices the linen manufactory was finally started. The society is believed to have been the first formed in this country for the development of an industry and to provide employment for the poor. The Linen Manufactory House thus established was not the same as the manufactory house which was built in 1753 on Long-acre Street, now Tremont Street, at the junction with Hamilton Place, by the General Court of Massachusetts.

The Linen Men's House on the Common advertised for yarn in 1750. Homespun garments of all kinds, hemp, flax, and wool, were now being made by the colonists, and spinning and weaving seemed to be the one industry that received the patronizing care of the colonial government. The records of the General Court are full of enactments relating to this industry.

Cotton up to this time was largely imported from the West Indies, as the home spinners often filled the flax or

wool warp with a cotton weft, and, as reported in 1756 by Governor Moore of New York, there were two kinds of woolen being made,—one, coarse, of all wool; the other, linsey-woolsey, of linen in the warp and woolen in the woof. Weavers were then wandering all over the country, weaving yarns that had been spun on the household looms.

THE SPINNING CRAZE

The settlement of one hundred Irish families in 1718 at Nutfield, now Londonderry, N.H., on the left bank of the Merrimac, a few miles below Manchester, gave an impulse to the production of linen, and also influenced the starting of what has been termed the Boston Spinning Craze.

These Irish immigrants spun and wove the standard linen fabrics for which Ireland has long been famous, and their skill and industry stimulated the people of Boston to increase the amount and quality of the homespun production by thorough instruction in spinning and weaving. Classes in the industry had been held from time to time on the Common and in the upper part of the old State House, but no steps were taken to teach the art systematically until 1720, when a committee was appointed to see what could be done. They recommended procuring a house and hiring a weaver whose wife should instruct children in spinning flax. Their board was to be furnished for three months by the overseers of the town, and at the expiration of the three months the children were to have their own earnings. It was further recommended that the town should provide twenty spinning wheels, and a prize of five pounds was offered for the first piece of linen spun and woven that was worth four shillings per yard.

The next year the plan was changed to an offer of a loan of three hundred pounds without interest to any one who would start such a school. Other plans were suggested,

but it was not until 1721 that any decisive action was taken. Daniel Oliver then erected the first spinning school on "land below Harrison's Walk," at his own expense, and the school which had begun on the Common had a shelter.

Prizes were offered, and many strutted about in homespun clothes of their own making. The people wore woollen clothing mixed with linen or flax for summer wear, and spinning continued to grow in favor, and soon became popular among rich and poor alike. Justice Samuel Sewall speaks of a spinning-bee on the Common in which five hundred fashionable women took part. Spinning had become an occupation in every household.

At the second anniversary of Boston's Society for Promoting Industry and Frugality on Aug. 8, 1753, the Rev. Samuel Cooper preached a sermon before the society, and a collection of four hundred and fifty-three pounds was raised. Three hundred young women appeared that afternoon on the Common in a procession, accompanied by music, and men carrying a platform on which a weaver was operating a loom, and, seating themselves in three rows, they spun at their spinning wheels. Weavers, cleanly dressed in garments of their own manufacture, were also present.

Some of the enthusiasm may have been aroused by an act passed on the 23d of June, 1753, by the "Great and General Court of his Majesties Province of the Massachusetts Bay in New England," which granted fifteen hundred pounds to encourage the manufacture of linen. It provided that a tax be levied on every coach, chariot, chaise, calash, and chair within the province, to be paid by the owner thereof annually, except the governor, lieutenant governor, the president of Harvard, and the ministers of the province. The money was to be applied to the buying of a piece of land and building or purchasing a suitable house for carrying on linen manufacture.

Accordingly, a lot was bought Sept. 15, 1753, on Com-

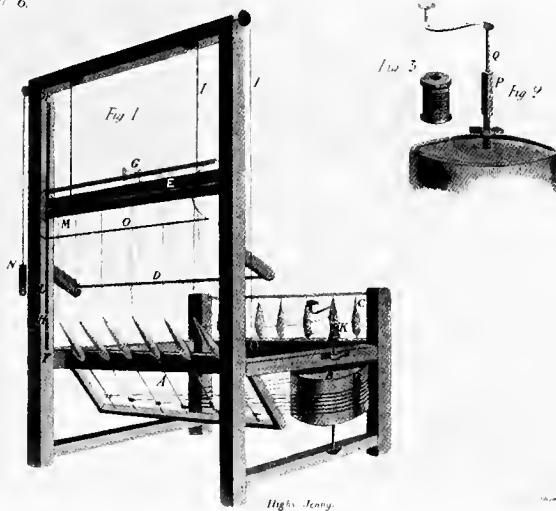

HIGH'S JENNY

(According to Richard Guest)

Figure 1.—*A*, the spindles, turned by strings from the drum *B*; *C*, the rovings; *D*, the wire loops; *E*, the clove, which rises and falls in the groove *FF*, and is opened and shut by the latch *G*. When the clove is down at the spindles, at *H* it is opened and the drum is turned, which raises the clove by means of the cord *H*, which, passing over pulleys, is coiled round the bobbin *K*. As the clove rises, the rovings slide through it. When the clove is raised five or six inches to *L*, it is shut fast by the latch *G*, the drum is again turned, which sets the spindles in motion and raises the clove by the coiling of the cord round the bobbin. The rising of the clove draws out the five or six inches of roving shut fast between the spindles and the clove into weft. When the clove is raised to *M*, the roving is sufficiently drawn out. The bobbin is then moved by a latch from the lower part of the bore of the bobbin. The drum is then turned, and the spindles again revolve, giving to the weft the necessary twist. During this twisting of the weft, the clove and the bobbin remain stationary, the axle of the drum turning within the bobbin, and a leaden weight, *N*, counterbalancing the clove. When twisted, the clove is lowered from *M* to *H* by the hand of the spinner, and the weft copped, or wound upon the spindles. The drop rod *O* guides the weft upon the spindles.

Figure 2.—The axle of the drum square at *P*, and round and of less diameter at *Q*.

Figure 3.—The bobbin, which when at *P* turns with the axle, but when at *Q* remains stationary.

mon Street, and a handsome brick building erected, which was later known as the Manufactory House. The west end fronted on Longacre, now Tremont, Street, and on the wall was the sign of its purpose in the form of a female figure holding a distaff. The building was in operation under the auspices of the society until 1758.

An advertisement in the *Boston News Letter* of Sept. 9, 1762, showed that the spinning school was then again opened under the direction of John Brown, who was engaged in the making of linen. John Brown continued in peaceful possession until 1768, when an effort was made to dispossess him in order to use the building as barracks for the British soldiers, who then occupied Boston. When Brown refused to get out, the sheriff and the chief justice proceeded to the house, but Brown locked the doors, and informed them through the window that only an order from the General Court could move him. Next day the sheriff came again with his deputies, and climbed in the cellar window. Brown showed his mettle by immediately declaring the sheriff his prisoner. Then a guard was sent to protect the sheriff, but it was finally called off, and Brown was left in possession; and the soldiers were accommodated elsewhere.

APPROACH OF THE REVOLUTION

The English policy of making the colonies dependent, as far as possible, upon the home country for manufactured goods, particularly textiles, had much to do with hastening the slow approach of the Revolution. But, despite this short-sighted policy, in many different parts of the colonies homespun garments were being made of cotton and wool in greater and greater quantities with more and more skill.

The enactment of the Stamp Act and the approach of the Revolution caused a greater demand for domestic goods, and also brought the social prestige of the leaders of

public opinion to further the spread of the textile industry by their advocacy of a refusal to use English goods.

The desire to promote domestic manufacture caused in New York the formation in November, 1764, of "the Society for the Promotion of Arts, Agriculture, and Economy," the principal object of which was to encourage the manufacture of linen. For a number of years its encouragement took the form of premiums for the largest quantity of linen yarn and linen cloth spun by a resident of the province. In 1767 Governor Moore of that province reported to the British Board of Trade that there was a small manufactory of linen in New York City under the management of a man named Obadiah Wells, which was supported by the society. It used about fourteen looms and gave bread to several poor families. Coarse wool and linsey-woolsey was also, he said, being made in New York.

Providence, R.I., set an example in 1766, when the Daughters of Liberty held all-day sessions of spinning, and, as a result of their influence, the president and the first graduating class of Rhode Island College at Commencement in 1769 were clothed in fabrics of American manufacture. Men's and women's wear now included blue, black, and claret broadcloth. The Senior Class in 1768 at Harvard College, Cambridge, was much commended for agreeing to graduate dressed wholly in native fabrics.

At the opening of the Revolution New England was supplying the demand for cheap clothing; while silk, owing to the encouragement that England, hoping to take this trade from France, gave to this branch of the textile industry, had made a good start in Connecticut, Pennsylvania, Georgia and South Carolina. Silk culture was encouraged all over New England, and there is scarcely one of the New England cities that has not its Mulberry Street, named from the trees which were set out to furnish food for silkworms.

For all the finer cotton and woolen garments, however,

America was still dependent upon England, because English spinners and weavers were more skilful, and also had the advantage of the improvements in textile machinery, the exportation of which England so jealously guarded. Just before the Revolution, efforts were made in America to start manufacturing with machinery, but the absence of artisans who knew how to construct the machines of Hargreaves and Arkwright rendered these attempts futile.

IMPROVEMENTS IN ENGLISH TEXTILE MACHINERY

The great improvements in the textile machinery in England from 1738, when Lewis Paul took out the first patent for improvement in spinning cotton, to 1775, when Arkwright completed his great invention, revolutionized the English industry and promised to give England control of the world's textile market. England, not slow to perceive the great advantage within her grasp, adopted stringent measures to prevent a spread of the knowledge of the various textile machines, and Parliament in 1774, to restrict to England a monopoly of the textile machinery which the inventive genius of her workmen was rapidly perfecting, as well as to prevent the development of the industry in America, prohibited the exportation of the machinery, and attempted to prevent with severe penalties the emigration of textile artisans.

One of the first steps to improve American manufacturing was taken by that far-sighted early Quaker merchant of Philadelphia, Samuel Wetherill, Jr., who, March 16, 1775, entered an agreement of copartnership with a number of others in Philadelphia under the title "The United Company of Philadelphia, for Promoting American Manufactures." It set up the American manufactory for woolens, cottons, and linens in a house rented for forty pounds a year, at the south-west corner of Ninth and Market Streets, about where a part of the post-office now is, and the factory

continued to prosper until the occupation of Philadelphia by the British put it out of business. The yarn was spun upon a spinning jenny made by Christopher Tully and capable of spinning twenty-four threads. He was the first in America to build a machine from a model of Hargreaves. The attempt to use the jenny was not wholly successful, but the manufactory paid a dividend and ran in all about two years.

During the Revolution the imports from England fell off, and the colonies, being thrown upon their own resources, continued to develop the industry which clothed them; and better and better fabrics were turned from their looms. The first to make jeans, fustians, everlastings, and coatings in America on a commercial scale, was probably the aforesaid enterprising Samuel Wetherill, Jr. His goods were sold at his dwelling-house and factory, on what was then South Alley, between Market and Arch Streets and between Fifth and Sixth Streets, Philadelphia. This was prior to April 3, 1782, when his advertisement appeared in the *Pennsylvania Gazette*.

John Hewson, the first calico printer, came to this country from England at the invitation of Benjamin Franklin, and worked at his trade in Philadelphia. He was taken prisoner at the battle of Monmouth, and escaped. Thereupon the British, because of his skill in a branch of manufacture in which England wished to suppress colonial competition, offered a reward of fifty guineas for his head. After the Revolution he continued in business, and in 1789 received from the State treasury a loan of two hundred pounds, to enable him to carry on the business of calico printing and bleaching.

CONDITION OF THE MARKET IMMEDIATELY AFTER THE
REVOLUTION

The close of the Revolution gave the English manufacturers of fabrics an opportunity to flood the American market with the one production which their activity during the Revolution had created in England, and English goods from 1783-87 were sold in America at prices less than their cost in Europe and for much less than they could be manufactured on this side. Some of the States imposed high duties upon fabrics manufactured by other States. This duty between the States, together with the low cost of English-made fabrics, was a serious detriment to American manufacturing, and numbers of persons in different parts of the United States undertook movements to promote American industries.

Some knowledge of the new labor-saving machines reached America from England, but nothing very definite about them was known because of the precautions England had taken to prevent the knowledge spreading abroad. So stringent were these acts that it was not until after 1770 that it was possible to secure from England designs and models of the new machinery, and then only with the utmost difficulty, owing to the prohibitory legislation. Some Hargreaves jennies and carding machines had been smuggled in, but none of Arkwright's machines, so that until Samuel Slater constructed these machines in 1790 at Pawtucket every attempt to make yarn by water power had failed.

AMERICAN EFFORT TO SECURE ENGLISH MACHINES

All kinds of expedients were tried by Americans to obtain either designs or copies of the English machines. Tench Coxe, a public-spirited Philadelphian, at his own expense had sent an English mechanic, who was living in Philadelphia, to construct brass models of the Arkwright machines.

The models were to be shipped to Paris, and through the agency of the American minister reshipped to America. The designs of the mechanic were discovered, the models were seized, and the mechanic himself was bonded not to leave England for three years.

At another time, models were packed and shipped to France, to be repacked and reshipped by the American minister to France, but they were seized in transit. Again, when an English artisan had succeeded in smuggling himself aboard a ship bound for America, the ship was stopped, searched, and the artisan seized and brought back to England and put under bonds not to leave. In some instances, machines were bought in England, taken apart, boxed separately, labelled agricultural implements, and reshipped to America. For instance, card clothing was mounted on handles and called "cards for cattle"; while the spindles were called "teeth for horse-rakes." In other instances the machines were cut up in small pieces, shipped as glassware to France, and reshipped to America. It was not long after 1800 that the makers of textiles on this side of the water were almost as well equipped with English machines as were the English themselves.

ENGLAND AND COTTON

According to Bain's "History of Cotton," the importation of cotton in 1730, before the invention of the fly shuttle, was but 1,545,472 pounds, and the value of the cotton goods exported was 13,524 pounds; while in 1800, thirteen years after the invention of Cartwright's loom and Watt's steam-engine, the cotton imported was 56,010,732 pounds, and the exports were 5,406,501 pounds. The value of the product in 1787 was 3,304,371 pounds sterling, or five and one-half times that of 1766.

Cotton was being used in 1787 in the one hundred and forty-three mills in England, Scotland, Wales, and the Isle

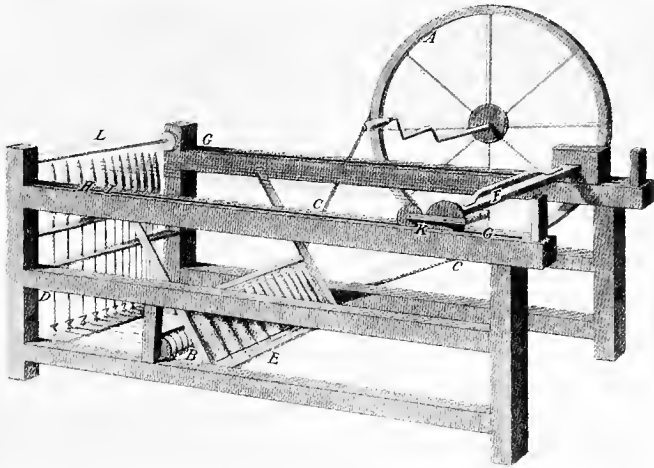

IMPROVED JENNY

(According to Guest)

The wheel *A* turns the cylinder *B* by a band *CC*. The spindles are turned by strings from the cylinder *B*. The rovings are placed on the frame *E* and pass through the clove *F* to the spindles. The clove moves in the groove *GG*. When the clove is close to the spindles at *H*, it is opened and drawn from them eight or ten inches to *I*, the rovings sliding through it. It is then shut fast, and the spindles are set in motion by turning the wheel *A*. As the spindles revolve, the clove is drawn back from *I* to *K* by the left hand of the spinner: this stretches out the rovings into weft. When stretched out, the spinner holds the clove at *K* with the left hand, and gives the proper degree of twist by turning the wheel *A* with the right hand. The weft is then copped by turning the clove to *H*. *L*, the drop rod. The spindles in the first improved jennies were turned by strings from a drum on a perpendicular axis.

of Man as follows: calico and muslins, 11,600,000 pounds; fustians, 6,000,000 pounds; mixtures with silk and linen, 2,000,000 pounds; hosiery, 1,500,000 pounds; candlewicks, 1,500,000 pounds,—making a total of 22,600,000 pounds. 162,000 hands were employed in the industry.

Before Arkwright, printed calicoes were made of linen warp and cotton weft, because the cotton spun by hand was not strong enough to use for the warp. After Arkwright had strengthened the warp, manufacturers could not be persuaded to use it, and when Mr. Jedediah Strutt, Mr. Arkwright's partner, successfully wove cotton warp into calico, he was under the law subjected to a double duty and had to petition Parliament before he secured relief.

In 1780 there were twenty water-frame factories using Arkwright's patent in England. After 1785, when the court declared his patents void, the factories sprang up so rapidly that by 1790 there were one hundred and fifty in England and Wales. Before 1787 not only had the United States not exported any quantity of domestic cotton, but no planter had adopted its cultivation as a staple crop. Cotton was then secured from the East and West Indies and Brazil, for it was not until 1784 that England commenced to import cotton from the United States.

STARTING OF COTTON CULTIVATION IN THE SOUTH

One of the first things to which Tench Coxe, who subsequently became Assistant Secretary of the Treasury under Alexander Hamilton, turned his enterprising mind, was to the problem of the production of cotton in the colonies. He was early convinced of its feasibility, despite that prior to 1736 cotton, save as a garden flower, was uncultivated in the South. It was in 1736 being raised as a garden flower as far north as Talbot County, Maryland, and elsewhere on the eastern shore of Maryland, the lower coun-

ties of Delaware, and other places in the Middle States, but its useful qualities soon were recognized, and its regular cultivation for fabrics was begun in those sections. Coxe, having learned of the labor-saving machines in Great Britain and having secured more or less accurate knowledge of great importance to the cotton industry, turned his mind to increasing the production of cotton by its cultivation in the South, that "the Cotton Spinning Mill might be brought into very beneficial use in the United States." He took effective measures to interest the whole community, particularly the planters of the five original Southern States.

But Coxe found it a slow task to interest the planters of these five States. At the convention held in 1786 at Annapolis to consider what means could be used to improve the industrial condition of the country, James Madison, later President, who was a member of the convention, said in a conversation with Coxe, "There was no reason to doubt that the United States would one day become a great cotton-producing country."

And in the same year Thomas Jefferson wrote to M. de Warville, under date of August 15: "The four southernmost states make a great deal of cotton. Their poor are almost entirely clothed in it winter and summer. In winter they wear shirts of it, and outer clothing of cotton and wool mixed. In summer their shirts are linen, but the outer clothing cotton. The dress of the women is almost entirely of cotton manufactured by themselves, except the richer class, and even many of these wear a good deal of homespun cotton. It is as well manufactured as the calicoes of Europe. Those four states furnish a great deal of cotton to the states north of them, who cannot make, as being too cold."

The best evidence proves that the first culture of cotton in the South was made on the peninsula between the Delaware and Chesapeake Bays, and that the growth of cotton spread across to Western Maryland and Virginia, and so on extended until it had become the great Southern crop.

ORIGIN OF SEA ISLAND COTTON AND BEGINNING OF ITS
CULTIVATION IN THE SOUTH

The story of Sea Island cotton is much more precise. In 1785 Patrick Walsh, of Kingston, Jamaica, persuaded his friend, Frank Levett, who with his family and negroes was in a distressed condition, to settle on Sapelo, one of the islands off the coast of Georgia, and plant provisions. Walsh sent him in 1786 a large quantity of various seeds of Jamaica, and also three large sacks of the Pernambuco cotton seed. Levett wrote Walsh in 1789:—

“Being in want of the sacks for gathering in my provisions I shook their contents on the dung hill, and it happening to be a very wet season in the Spring, multitudes of plants covered the place. Those I drew out and transplanted them into two acres of ground and was highly gratified to find an abundant crop. This encouraged me to plant more. I used all my strength in clearing and planting, and have succeeded beyond my most sanguine expectations.” Thus it was that Sea Island cotton originated, the most valuable of all cotton staples.

About the same time that Levett planted his cotton, James Spaulding, Colonel Robert Kelsal, and Governor Tatnall, all of Georgia, received parcels of the seed from friends who were exiled Royalists and who were living in the Bahamas, and planted them with excellent results. Levett’s cotton was sent to London, and sold to Glasgow manufacturers for four shillings, sixpence, per pound. The purchasers said that they had never seen cotton so good and promised to take all that would be procured. The London agents, Simpson and Davidson, were told to inform their friends that the market could not be overstocked, so superior was the long-stapled, silky Sea Island cotton to that which England was getting from the East and West Indies.

Twenty persons in 1789 were growing Sea Island cotton

in Georgia, but it was not extensively raised in South Carolina until 1799.

The influence of Tench Coxe induced Congress in 1789 to protect the Southern growers by placing a duty of three cents a pound on foreign cotton. At this time the production of cotton, according to an estimate of the Treasury Department, was about one million pounds. In 1790 it was a million and a half, and in 1791 two million pounds, three-fourths of which came from South Carolina and the rest from Georgia.

The invention of Whitney's gin enormously increased, as we have seen, the production of cotton by making it easy to separate the fibre from the seed, and cotton soon became the great staple crop of the South.

According to a letter written by Richard Teake, of Savannah, Ga., to Thomas Proctor, of Philadelphia, dated Dec. 11, 1788, the year 1788 marked the introduction of cotton growing on a large scale in the Carolinas and Georgia:—

“I have been this year an adventurer and the first that has attempted on a large scale in the articles of cotton. Several here, as well as in Carolina, have followed me and tried the experiment. I will raise about 5,000 pounds in the seed from about eight acres of land and next year I expect to plant fifty to one hundred acres. The lands in the southern part of this state are admirably adapted to the raising of this commodity. The climate is so mild so far to the South, scarce any winter is felt and another advantage—whites can be employed. The labor is not severe attending it; not more than raising Indian corn.”

Cotton was undoubtedly shipped from the colonies to England in 1747, 1753, 1757, 1764, and 1770. In fact, a reproduction of a bill of lading for eighteen bales of cotton shipped July 20, 1751, from New York to London on the vessel of Captain Barnaby Badgers, is reproduced in Chew's “History of the Kingdom of Cotton and Cotton Statistics

of the World." It has been claimed that this was a reshipping of cotton grown in the West Indies. Whether or not this is true, the fact remains that some of the cotton grown either for floral purposes or home industry in the colonies did find its way to Europe. Another authority says that Samuel Auspourgouer, a Swiss living in Georgia, took to London in 1739, at the time of the controversy over the introduction of slaves, a sample of the cotton raised by him in Georgia.

Jefferson mentions cotton as an article of export from Virginia previous to the Revolution. The real beginning of the cotton trade between the United States and Great Britain was in 1784, when Mr. Rathbone, an American merchant in Liverpool, received a consignment of eight bales of cotton, which were seized by the custom-house on the ground that they could not have been raised in the United States and were liable to seizure under the Shipping Act "as not being imported in vessels belonging to the country of growth." When its place of growth was proven to be the United States, so undesirable was the quality of the cotton that it lay in the warehouse some months after its release by the government before it could be sold. In 1785 fourteen bags were sent over, in 1786 six bags, and in 1787 one hundred and nine bags, of about one hundred and fifty pounds each, reached Liverpool.

In 1788 58,350 pounds were exported, and Sea Island cotton formed the bulk of the exports until 1793, and from this time on the exports of cotton rapidly increased, and cotton cultivation spread over the South until cotton had become the great staple crop, supplying the European industry as well as the American.

CHAPTER VI

AMERICAN INDUSTRY AFTER THE REVOLUTION AND BEFORE SLATER

FIRST MANUFACTURING IN PENNSYLVANIA—FIRST COTTON MILL IN NEW ENGLAND—FIRST TEXTILE TRADE-MARK—FIRST TEXTILE ADVERTISING—BOSTON SAIL CLOTH FACTORY—COMMENCEMENT OF THE COTTON INDUSTRY IN RHODE ISLAND—FIRST WOOLEN MILL—WASHINGTON INAUGURATED IN SUIT OF DOMESTIC WOOLEN—FIRST WOOLEN MILL OPERATED WITH POWER MACHINERY

The most influential of the early movements to promote textile manufacturing originated in Philadelphia, where cotton manufacturing with power machinery began in 1764, and according to the *Complete Magazine*, published in London that year, "Some beautiful samples of the cotton manufactures now carried on in Philadelphia have been lately imported and greatly admired." Through the efforts of Tench Coxe, Samuel Wetherill, Jr., and others, a society called "The Pennsylvania Society for the Encouragement of Manufactures and the Useful Arts," which was an outgrowth of the United Company of Philadelphia, was organized on the 9th of August, 1787, at a meeting held at the University of Pennsylvania. The necessity of promoting and establishing manufactures was pointed out in an address by Tench Coxe. Every member on admission paid to the treasurer the sum of ten shillings and the same sum annually for the purpose of defraying the necessary expenses of the society, and a subscription of not less than ten pounds was opened, and called the "manufacturing fund," for the purpose of establishing factories in such places as might be thought suitable.

The society on Aug. 23, 1788, had received thirteen

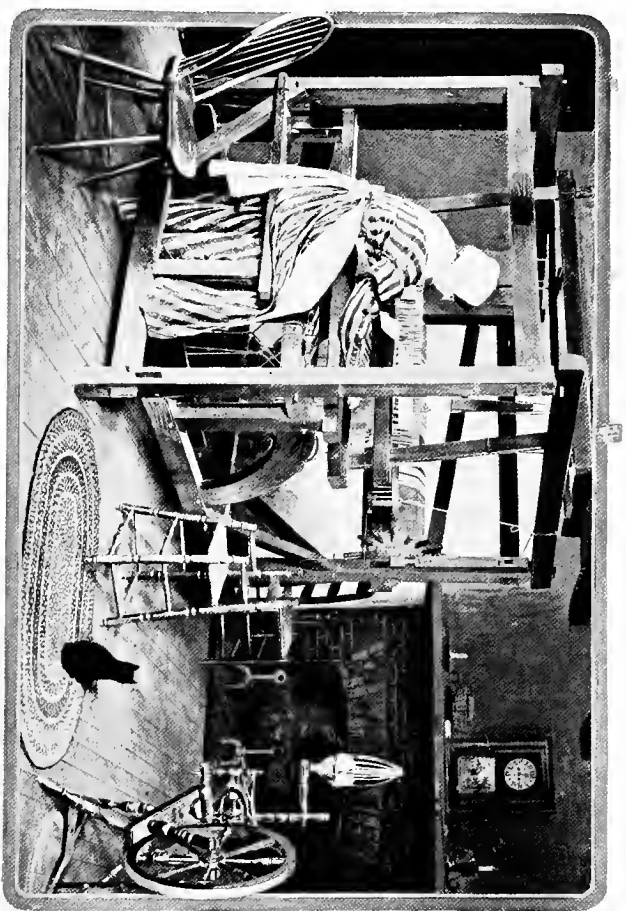

A HANDICRAFT WEAVER AT HER LOOM

(Courtesy of the Draper Company)

Showing the primitive construction of the loom used before the power loom.

hundred and twenty-seven pounds, ten shillings, and sixpence, had spent four hundred and fifty-three pounds, ten shillings, and twopence for machines, utensils, and equipping the house of the old United Company of Philadelphia for the manufactory, and had a capital left of eight hundred and seventy-four pounds, no shillings, and fourpence. As one of the objects of the society was the employment of the poor, a quantity of flax was bought, and between two and three hundred women were employed during the winter and spring in spinning linen yarn. Workmen were engaged to make a carding machine and four jennies of forty, forty-four, sixty, and eighty spindles for spinning cotton. As soon as possible the house was fitted up and the machines set to work. Various obstacles, such as finding proper workmen, making machines from imperfect models, various obstructions thrown in the way by agents of foreign manufacturers, combined to delay the work, so that it was the 12th of April, 1788, before the first loom was set to work. This was twelve days before the Beverly Cotton Manufactory turned out goods from its new mill, and, if the Beverly proprietors did not make any goods until moving into the Beverly mill, to Philadelphia belongs the distinction of establishing in America the first cotton mill with power machinery.

If when the Hon. George Cabot wrote to Alexander Hamilton that the Beverly gentlemen were engaged in the cotton manufacturing in October, 1787, he meant that they were then turning out cotton fabrics by machinery, the honor of being the first to engage in cotton manufacturing with machinery belongs not to Philadelphia, but to Massachusetts. If he simply referred to the fact that these men were engaged in promoting a cotton manufactory, then any distinction which springs from the establishment of the first cotton mill in America belongs without question to Pennsylvania.

The number of looms in Philadelphia was speedily in-

creased to twenty-six, and the following goods had been made up to Aug. 23, 1788: jeans, 2,959½ yards; corduroy, 197½ yards; federal rib, 67 yards; beaver fustian, 57 yards; plain cotton, 1,567½ yards; linen, 725 yards; tow linen, 1,337½ yards; total, 7,111 yards. In the looms at that time there were 200 yards of jeans, corduroys, cottons, and linens. The manufactory had sold manufactured goods, of jean, and cotton, and linen yarn, fine and tow linen, to the value of four hundred and forty-eight pounds, five shillings, eleven pence, one-half penny. By the first of November the manufactory had made in addition: jeans, 759½ yards; corduroy, 383½ yards; flowered cotton, 39 yards; cottons, 2,095 yards; flax linen, 123 yards; tow linen, 494 yards; bird's-eye, 123 yards,—making a total of 4,016 yards. The cotton yarn sold in Philadelphia for one dollar a pound.

There were also about two hundred and forty yards of different goods in the looms, amounting in all to 11,367 yards, and 185 pounds of plain and colored knitting thread had been made by the twisting mill. 190 yards of cotton had been printed, showing that by November, 1788, the output was considerable. None of these early efforts amounted to much because of the better goods turned out by the more perfect machines of English manufacturers. Then, too, from 1782 to 1789 the poverty and business depression in the United States were wide-spread, and proved a serious obstacle to the successful starting of new enterprises. The manufactory was finally burned March 24, 1790, and the mill in which horse-power ran some of the machines was not rebuilt.

FIRST COTTON MILL IN NEW ENGLAND

The first cotton mill in New England, if not in America, was that established by the proprietors of the Beverly Cotton Manufactory at Beverly, Mass. The production of cotton goods at their mill preceded by at least a year

the first products of Samuel Slater's mill at Pawtucket, but seems to have been a little later than the establishment of cotton manufacturing by the Pennsylvania Society for Promoting Manufactures and Useful Arts in Philadelphia. Unsuccessful attempts at spinning and weaving cotton had been made in 1780 at Worcester.

The interest in cotton manufacturing had been greatly stimulated by the action of the legislature of Massachusetts in 1786, and therefore before the thirteen States had become the United States of America. This legislature had on the 25th of October, 1786, appointed a committee of three—Mr. Richard Cranch of the Senate and Mr. Clarke and Mr. Bowdoin of the House—"to view any new invented machines that are making within this Commonwealth for the purpose of manufacturing sheep's and cotton wool, and report what measures are proper for the Legislature to take to encourage the same."

The committee examined at the works of Colonel Hugh Orr, the machines for carding and spinning that had been made at Bridgewater, by Robert and Alexander Barr, and at the suggestion of the committee the legislature granted the Barrs two hundred pounds to enable them to complete three machines, a roving machine, and to construct several other machines as might be necessary for carding, roping, and spinning cotton and wool.

Colonel Orr was a Scotchman who had settled in Bridgewater in 1740 and had been engaged in the manufacture of firearms. At the commencement of the Revolution he had made the first cannon produced in the country by boring a solid casting. Having become interested in the carding and spinning machines which he learned were being made in England, he had successfully urged Robert and Alexander Barr, two brothers, who were skilful Scotch mechanics, to come to America and construct textile machinery at Orr's works.

The Massachusetts legislature continued to watch with

much interest the progress of the Barrs, and on March 8, 1787, Richard Cranch was appointed by the Senate "with such as the House should join to examine the machines which are now nearly completed and to inspect and allow the account of Robert and Alexander Barr and also to report to the next General Court, what gratuity in their opinion the said Robert and Alexander justly deserve, as a reward for their ingenuity in forming these machines, and as an encouragement for their public spirit in making them known to this Commonwealth." The committee passed their account for one hundred and eighty-nine pounds and twelve shillings, which included the expense of transporting the machines to and from Boston, that the legislature could see them.

Thomas Somers, a Scotchman who had been a midshipman in the English navy, petitioned the legislature of Massachusetts, Feb. 15, 1787, on the subject of textile machinery, and represented that in the fall of 1785, while he was residing in Baltimore, tradesmen and manufacturers of that city had been influenced by a circular letter sent by a committee of the tradesmen and manufacturers of Boston to form themselves into an association for applying to the legislature in behalf of American manufacture. Somers said he had been brought up in cotton manufacturing, and, being willing to do what lay in his power to introduce the manufacture in America, at his own risk and expense had gone to England to prepare machines for carding and spinning cotton. He found after much difficulty that he could only secure descriptions and models of the textile machines. With these he had returned to Baltimore. Finding that the merchants of Baltimore were very dilatory about encouraging the matter, he resolved to take the advice of friends and try his success in Boston.

To encourage the textile manufacture and to give Somers an opportunity to prove his ability to perfect the manufacture, the legislature, March 8, 1787, granted him twenty

pounds, which were deposited with Colonel Orr, who was made a committee to supervise the expenditure. Somers, under the direction of Orr, constructed other textile machinery in addition to that already made by the Barrs, and about the same time Mr. Orr employed a Scotchman by the name of McClure to weave jeans and corduroy by hand with the fly shuttle. This was probably the first use in America of the fly shuttle.

The legislature on May 2, 1787, discharged the Barrs from any obligations under the grant of two hundred pounds, and granted them six tickets in the land lottery which had no blanks. It was further provided that the machines they and Somers had made should be left in charge of Colonel Orr, with the proviso that he should "explain to such citizens as may apply for the same the principles on which said machines are constructed and the advantages arising from their use, and also to allow them to see the machines at work." These machines were subsequently known as "The State Models," and the ones made in 1786 by the Barrs were the first jennies and stock cards made in the United States. They served as the models from which many who were interested in the construction of textile mills got their ideas for the machinery which was first used. But these models were very imperfect and of little use.

The legislature had also provided that public notice of the machines be given by advertising three weeks consecutively in Adams and Nourse's newspaper that the models could be seen and examined at Colonel Orr's in Bridgewater. They also included crude reproductions of Arkwright's roller spinning and other textile improvements, but they all had vital defects which made them impractical, so that Samuel Slater constructed the first practical Arkwright machines in America.

These Bridgewater experiments centred attention on the possibilities of the textile industry, and undoubtedly

influenced the proprietors of the Beverly factory to take up cotton spinning. The cotton used in these Bridgewater experiments, as well as that used later at the Beverly factory, came from Barbadoes, Surinam, Pernambuco, Cayenne, and other places in the West Indies and South America, and was imported in exchange for fish which New England exported. The cotton was often mixed with linen or sheep's wool, and was originally sold in the shops by the pound for domestic use.

One of the prime movers in the organization of the Beverly cotton manufacture was the Hon. George Cabot, who wrote to Alexander Hamilton, the first Secretary of the Treasury, and to Benjamin Goodhue, Massachusetts' first member of Congress, that the Beverly manufacturers were engaged in the cotton industry as early as October, 1787. The *Salem Mercury* on April 22, 1788, stated that "several public-spirited gentlemen in Beverly have procured a complete set of machines for carding and spinning cotton, with which an experiment was made a few days ago, answering the warmest wishes of the proprietors. The jenny spun sixty threads at a time, and with carding machine forty pounds of cotton can be well carded in a day,—the warping machines, and the other tools and machinery, part of which go by water, are all complete,—perform their various operations to great advantage, and promise much benefit to the public and emolument to the patriotic adventurers."

A few weeks later the same newspaper said that a "Mr. Leonard and Mr. Somers," who understood the making and finishing of velvets, corduroys, jeans, fustians, denims, marseilles quiltings, dimity, muslins, etc., had introduced into Beverly the machines for carding and spinning. They had the patronage of the Hon. George Cabot, who had secured the influence of a number of gentlemen in Beverly to organize for the purpose of establishing the industries.

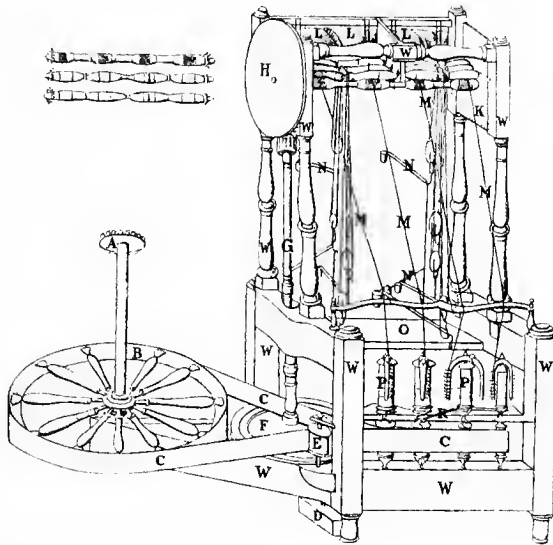

ARKWRIGHT'S ORIGINAL WATER FRAME WITH THE SPECIFICATIONS
ON THE ORIGINAL PATENT PAPERS TAKEN OUT BY HIM ON JULY
15, 1769.

“Now know ye that I, the said Richard Arkwright, do hereby describe and ascertain the nature of my said invention, and declare that the plan thereof drawn in the margin of these presents is composed of the following particulars, (that is to say) *A*, the Cogg Wheel and Shaft, which receive their motion from a horse. *B*, the Drum or Wheel which turns *C*, a belt of leather, and gives motion to the whole machine. *D*, a lead weight, which keeps *F*, the small drum, steady to *E*, the forcing Wheel. *G*, the shaft of wood which gives motion to the Wheel *H*, and continues it to *I*, four pair of Rollers, (the form of which are drawn in the margin,) which act by tooth and pinion made of brass and steel nuts fixt in two iron plates *K*. That part of the roller which the cotton runs through is covered with wood, the top Roller with leather, and the bottom one fluted, which lets the Cotton, &c. through it; by one pair of Rollers moving quicker than the other, draws it finer for twisting, which is performed by the spindles *T*. *K*, the two iron plates described above. *L*, four large Bobbins with cotton rovings on, conducted between Rollers at the back. *M*, the four threads carried to the Bobbins and Spindles by four small wires fixt across the frame in the slip of wood *V*. *N*, iron leavers with small lead weights hanging to the Rollers by Pulleys, which keep the Rollers close to each other. *O*, a cross piece of wood to which the leavers are fixed. *P*, the Bobbins and Spindles. *Q*, Flyers made of wood, with small wires on the side, which lead the thread to the bobbins. *R*, small worsted bands put about the whirl of the bobbins, the screwing of which tight or easy causes the bobbins to wind up the thread faster or slower. *S*, the four whirls of the spindles. *T*, the four Spindles, which run in iron plates. *V*, explained in letter *M*. *W*, a wooden frame of the whole machine.”

FIRST TEXTILE TRADE-MARK

These men, who on June 6, 1788, petitioned the legislature for incorporation, which was granted on Feb. 3, 1789, were John Cabot, George Cabot, Deborah and Andrew Cabot, Moses Brown, Joshua Fisher, Israel Thorn-dike, James Leonard, Thomas Somers and Isaac Chapman, of Beverly, and Henry Higginson, of Boston. They were given permission to hold real estate to the amount of ten thousand pounds and personal estate to the amount of eighty thousand pounds for the purpose of manufacturing textiles; "and be it further enacted by the state aforesaid," read the charter, "that all goods which may be manufactured by the said corporation, shall have a label of lead affixed to one end thereof, which shall have the same impression with the seal of the said corporation, and that if any person shall knowingly use a like seal or label with that used by said corporation, by annexing same to any cotton or cotton and linen goods, not manufactured by said corporation with a view of vending or distributing thereof, as the proper manufacture of the said corporation, every person so offending shall forfeit and pay treble the value of such goods, to be sued for and recovered for the use of said corporation, by action of debt, in any court of record proper to try the same."

This shows conclusively the first cotton mill in New England was wise enough to trade-mark its goods, and it also advertised them for sale in Salem and Beverly under the trade-mark.

The five or six acres on which the factory stood adjoined the Beverly Tavern on "the road from Mr. Oliver's meeting-house to Beverly Ferry," and was purchased Aug. 18, 1788, for eighty pounds and five shillings, by John Cabot, merchant, and Joshua Fisher, physician. Work was at once commenced on the mill, and before Jan. 6, 1789, it was completed. The Salem *Mercury* speaks of the

“promising cotton manufactory at Beverly,” and it is described as “a plain three story building of brick, measuring about sixty by twenty-five feet with a pitching shingled roof, and a deep basement, in one end of which moved a heavy pair of horses to furnish rotary power.” The horses were driven by a boy, Joshua Herrick, of Maine, who afterwards became a member of Congress. When the horses went too fast, Mr. Somers would call out the window, “Hold on there! not so fast! Slower!” and Herrick would slow up, but soon he would forget and speed up again, when again Somers would cry out, “Hold up!” and this continued most of the day. In a corner of the lot stood a small wooden dye-house. The mill stood about seventy feet behind the tavern yard.

In a letter written to Alexander Hamilton by George Cabot, Sept. 6, 1791, the number of employees is given as forty, thirty-nine of whom were native. The machines were enumerated as follows: “one carding machine with the labor of one man carded fifteen pounds per day, and with the labor of two men was capable of carding thirty pounds per day; nine spinning jennies, of sixty to eighty-four spindles each; one doubling and twisting machine, constructed on the principle of the jenny; one stubbing machine, or coarse jenny, to prepare the ropings for the finest jennies, whereon they are fitted for doubling and twisting; one warping mill, sufficient to perform this part of the work for a very extensive manufactory; sixteen looms with flying shuttle, ten of which are sufficient to weave all the yarn our present spinners can finish; two cutting frames, with knives, guides, etc.; one burner and furnace, with apparatus to singe the goods; apparatus for coloring, drying, etc.”

According also to Mr. Cabot, actual expenditures on the enterprise had been about \$14,000; of which the building had cost \$3,000, machinery and apparatus \$2,000, goods and unwrought material \$4,000, sunk in waste of

materials, extraordinary cost of first machines, in maintaining learners and compensating teachers, etc., \$5,000. He wrote that the net loss to the manufacturers had been about \$10,000 and the interest on their money, and that the legislature of Massachusetts had granted aids in lands and lottery tickets to about \$4,000. The mill was then turning out 8,000 to 10,000 yards per year.

The incorporators found from the outset of their enterprise the construction of the proper machinery not only difficult, but expensive, and they applied to the legislature for aid, and on Feb. 17, 1789, were granted five hundred pounds, to be paid from the proceeds of eastern lands of the Commonwealth, with the condition that the petitioners should manufacture, within seven years from the date of the grant, cotton and cotton and linen goods of a quality usually imported to the amount of fifty thousand yards. As the grantees found the eastern lands not available for raising the money they required, in June they again petitioned the legislature, representing they had expended about four thousand pounds, and that the present value of this stock was not equal to two thousand pounds, and that, owing to the cost of machines (a carding machine is cited as costing eleven hundred pounds) and the difficulty and expense of carrying on the business, they must have some "very considerable advancement."

The House granted them thirteen hundred pounds to be obtained from a lottery, but the Senate refused the grant, and allowed seven hundred pounds on March 4, 1791, to be raised by lottery.

Washington made a tour of New England in 1789, and on October 30 took breakfast with George Cabot, and afterward visited the cotton mill on his way to Portsmouth. Senator Henry Cabot Lodge, in his "Some Early Memories," says that his grandfather, Henry Cabot, the son of George Cabot, used to tell how he hid under the sideboard and watched the "Father of his Country" at breakfast

with his father, when Washington stopped at Senator Lodge's great-grandfather's house on this occasion. According to the *Salem Mercury* of Nov. 3, 1789, Washington "was shown in the lower story a jenny of eighty-four spindles, upon which some of the manufacturers were spinning warp; and three or four other jennies upon which they were spinning weft, and about a dozen looms upon which they were weaving cotton denim, thicksett, corduroys, velveret, etc. In the middle story was seen a roping jenny of forty-two spindles and a machine on which a person usually doubles and twists in a day a cotton warp of fifty yards. In the upper story were exhibited the business of carding, working, and cutting; and in a contiguous building that of dressing on the stove." The goods there made were mostly a coarse fabric, and amounted to about ten thousand yards.

Washington, under date of Friday, October 30, wrote in his diary: "After passing Beverly two miles we came to a cotton manufactory, which seems to be carried on with spirit by the Cabots principally. In this manufactory they have the new invented carding and spinning machines; one of the first supplies the work, and four of the latter; one of which spins eighty-four threads at one time by one person. The cotton is prepared for this machine by being first lightly drawn to a thread on the common wheel.

"There is another machine for doubling and twisting the thread for particular cloths. This also does many at a time. For winding the cotton from the spindles and preparing it for the warp there is a reel which expedites the work greatly. A number of looms, fifteen or sixteen, were at work with spring-shuttles, which do more than double work. In short, the whole seemed perfect, and the cotton stuffs which they turn out excellent of their kind, warp and filling both are now of cotton."

FIRST TEXTILE ADVERTISING

The Beverly goods were advertised for sale from December, 1789. Baker & Allen, of Beverly, were selling the corduroys as the equal in price and quality with imported fabrics, and Francis Cabot at Salem also sold corduroys, royal ribs, thicksett, stockinette, and rib delures, wholesale and retail, and all made in Beverly and at lower prices than English goods of the same quality. In fact, by 1790 the wear of Beverly corduroys is said to have been common. Despite every effort, it was impossible to make the early mills pay, and we soon find Moses Brown, the patron of Slater, writing to Moses Brown, of Beverly, his namesake, asking the co-operation of the Beverly proprietors in petitioning Congress for an additional duty on cotton goods. It was also with difficulty that the employees of the Beverly mill could be kept, because as fast as they mastered the business they were enticed away by other manufacturers.

In fact, the Beverly enterprise met with more difficulties than usually confront a new industry, and finally, shortly before the Embargo Act of 1807, which paralyzed the industry, passed out of existence. A deed of land in 1813 describes it as follows: "A certain piece of land with brick buildings now thereon standing, with all the machinery and utensils formerly used for the manufacture of cotton which remain unsold," and until this date the machines and land were unsold. The old brick factory was finally burned in 1828.

BOSTON SAIL CLOTH FACTORY

As the result of a bounty offered by the Massachusetts legislature in 1788 for home-manufactured sail cloth, etc., a number of Boston merchants formed a company called the Boston Sail Cloth Factory. Land which was probably

an open pasture was rented for nine pounds a year at the corner of Frog Lane, now Boylston Street, and Holyoke, now Tremont Street, and by 1789 sixteen women and as many girls were working twenty-eight looms and were turning out forty yards per week.

Washington, who described it on his New England visit in 1789, wrote, "They have twenty-eight looms and fourteen girls, spinning with both hands, the flax being fastened to the waist. Children, (girls) turn the wheels for them; and with this assistance each spinner can turn out fourteen pounds of thread a day when they stick to it; but as they are paid by the piece or the work they do, there is no other restraint upon them but to come at eight o'clock in the morning and return at six in the evening. They are the daughters of decayed families; none others are admitted."

In 1792 about four hundred employees were turning out about fifty pieces of linen duck a week. As described in 1789 in the *Gazette* of the United States, "The manufacturing house for duck in Boston is pleasantly situated in the south west part of the town. The building is 180 feet long, two stories high. The upper part is improved by the spinners of chains or warp of the duck. Sixteen young women and as many girls under the direction of a steady matron are here employed. In the lower part there are twenty-eight looms which can turn out two pieces of duck of forty yards each per week."

A high degree of perfection was attained, and the business was very prosperous until about 1795, when the bounty was withdrawn and the business gradually died. In the mean time, however, duck had begun to be manufactured in Haverhill, Springfield, and in New Hampshire and Connecticut.

About the same time various other attempts at duck manufacturing were made elsewhere, one of them being in Worcester, where a factory was erected in 1789, and on April 30, 1789, the first piece of corduroy was turned out.

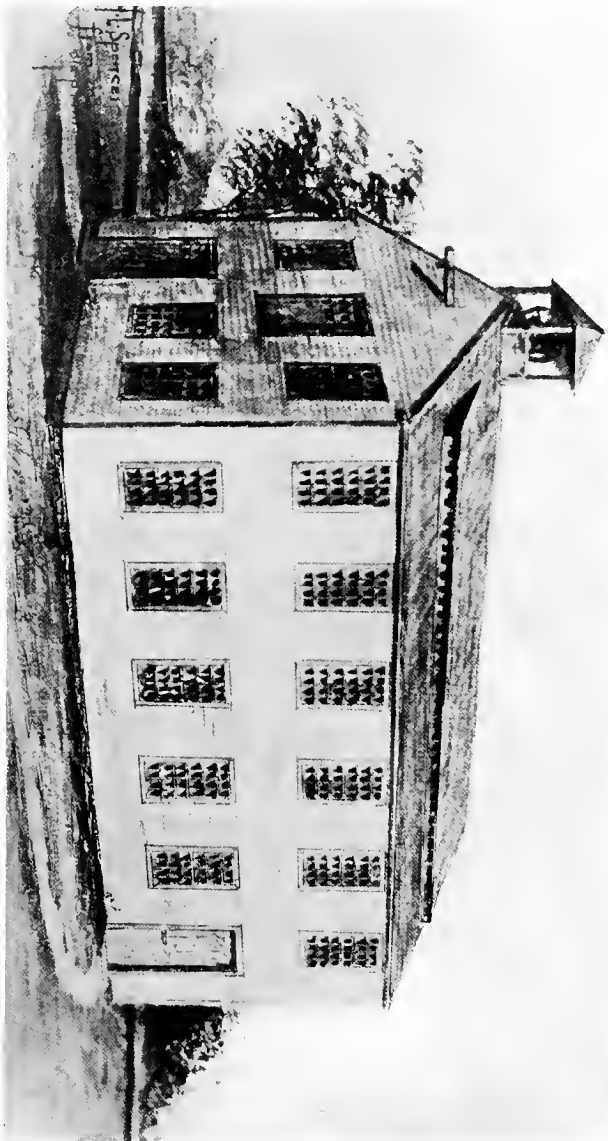

THE OLD SLATER MILL. PAWTUCKET, R. I.

(Courtesy of Job L. Spencer)

Built by Samuel Slater in 1793, in which was first introduced into America the spinning of cotton by Arkwright machines.
Sketch made by H. L. Spencer, whose grandfather, Gideon L. Spencer, worked in the mill.

Fustians, ribs, and corduroys were subsequently offered for sale. The enterprise, however, was not a success, and within a few years after it started passed out of existence. Other attempts were made at Colchester, Conn., at Exeter, N.H., at Haverhill, Mass., and also at Springfield, Salem, and Stratford.

COMMENCEMENT OF THE COTTON INDUSTRY IN RHODE ISLAND

Cotton manufacturing began in Rhode Island in 1788, and was due to the efforts of Daniel Anthony, Andrew Dexter, and Lewis Peck, of Providence, who formed a partnership to manufacture "Home Spun Cloth." It was the original purpose to spin by hand and make linen jeans with linen warp and cotton filling, but, learning of the Bridgewater experiments, Anthony and John Reynolds, of East Greenwich, who had begun the making of woollens, visited Bridgewater and made a sketch of the machine. Nothing was done with this sketch, for soon after they proceeded to build a jenny from a model of the machine that Somers had at Beverly. The construction of the woodwork was done by Richard Anthony, while the spindles and brasswork were made by Daniel Jackson, a coppersmith, of Providence. The jenny was set up in a private house, but was subsequently removed to a chamber in the market house, Providence.

A machine for carding cotton spun upon the lines of the sketch of a similar machine seen at Beverly was made by Joshua Lindly, of Providence, and a spinning machine, somewhat like the Arkwright frame, but very imperfect, was also built. It had eight heads of four spindles each, and was worked by a crank turned by hand. John Bailey, an ingenious clock maker, of Pembroke, Mass., made the first head, while the other seven, together with the brasswork and spindles, were the work of Daniel Jackson, the woodwork being by Joshua Lindly. In 1787 Joseph Alex-

ander and James McKerris, expert fly-shuttle weavers, had arrived in Providence, and were engaged to make corduroy. Alexander went to work in Providence, while McKerris took up the work in East Greenwich. The first fly shuttle in Rhode Island was built according to the directions of Alexander, and was operated in the market-house chamber. A piece of corduroy was woven, of a linen warp and filling of cotton, but, as there was no one who knew how to cut the corduroy or to finish it so as to raise the pile, the manufacture was abandoned, and Alexander went to Philadelphia. McKerris worked in East Greenwich for some years.

The spinning frame which had been made from the State model, after being tried in Providence, was taken to Pawtucket and attached to a wheel propelled by water, but the machine was so imperfect that it was set too hard to work by hand. Eventually, the machine was sold to Moses Brown, of Providence, who had become much interested in the textile industry. Brown, together with Smith Brown, a kinsman, also purchased the stocking loom of John Fullem, an Irishman, who had some time in 1788 commenced stocking weaving in East Greenwich, but, not prospering, went to Providence.

After selling his loom, Fullem operated it under the superintendence of Smith Brown, but the business, not proving successful, was given up. In the mean time, calico printing had been introduced by Herman Vandausen, a German calico printer, who settled in East Greenwich. He cut his design on wood, and printed for those who home-spun calico. This calico was little inferior to that imported from India, but Mr. Moses Brown, who was then trading with India and to whom the domestic cloth was shown, decided it was cheaper to import the Indian fabrics.

FIRST WOOLEN MILL

The first woolen factory in which water power was used, other than in the fulling process in which water power was early employed, and in fact the first large woolen mill in America, was that of the Hartford Woolen Manufactory, which was organized April 15, 1788, and started at Hartford, Conn., by a number of shareholders, of whom Jeremiah Wadsworth was the largest. Other stockholders were Oliver Wolcott, signer of the Declaration of Independence, and Peter Colt, uncle of the man who originated Colt's revolver. On the books of the company appears under date of Dec. 27, 1788, a charge for one piece of smoke cloth, $23\frac{3}{4}$ yards, and also for one piece of Hartford gray, showing that about then manufacturing began.

In order to encourage the industry, the Connecticut General Assembly passed a resolution exempting the buildings and employees from taxation, and offered a bounty of one cent per pound upon all woolen yarns woven into cloth before a certain date, and considerable perfection was soon attained in the production of the best cloths.

WASHINGTON INAUGURATED IN SUIT OF DOMESTIC WOOLEN

At the inauguration of Washington, April 3, 1789, the President, Vice-President, and the Connecticut senators were all clothed in fabrics made by this mill. Washington appeared dressed in a coat, waistcoat, breeches of fine dark brown cloth, and white silk stockings. Plain silver buckles were on his shoes, his head uncovered, and his hair dressed after the prevailing fashion of the time. In a letter to General Henry Knox, who sent him the suit, Washington wrote as follows:—

MT. VERNON, March 2, 1789.

My dear Sir,—I beg of you to accept my acknowledgment of and thanks for your obliging favors of the 12th, 16th, and 19th

of last month, and particularly for the trouble you have had in procuring and forwarding for use, a suit of the Hartford Manufacture. It is come safe and exceeds my expectation. I will take an early opportunity of paying the cost of it. I am ever yours,

GEORGE WASHINGTON.

“The cloth is of as fine a fabric,” said one of the newspapers, describing the President’s suit, “and so handsomely finished, that it is universally mistaken for a foreign manufactured superfine cloth.”

The proprietors of this mill, like the proprietors of the Beverly manufactory, believed in calling the public’s attention to their goods by advertising, and therefore they inserted in the *Connecticut Courant*, Sept. 14, 1789, and also in 1790, this advertisement:—

“American manufactured woollens for sale at the Hartford Woolen Manufactory. A great variety of cloths, sergings and coatings. The colors may be relied upon, being principally dyed in grain. They have lately established a blue dye where all the different shades from a pearl color to navy blue are dyed.” On Nov. 2, 1789, an advertisement read, “A great variety of fine, middling and coarse, broad and narrow cloths, serges, coatings, and baises, etc., by wholesale.”

In the year from September, 1788, to September, 1789, about five thousand yards of cloth were made, the spinning only being done outside by the country people. Broad-cloths of a good, but not first quality were produced, some of which sold as high as five dollars per yard. Their Hartford gray became a celebrated cloth. About 1789 one cloth presser finished in seven months, at one press, 8,133 yards, of which 5,282 yards were fulling coatings. Cassimeres, serges, and everlastings were also turned out. Early in colonial days and even after the starting of the Hartford Mill, worsteds that were woven into serges and everlastings were spun in the households.

It was difficult for the manufactory to get ahead, so it secured in 1790 from the General Assembly a grant of a lottery to further its interests, the proceeds being used for machinery, implements, and increase of stock. The *Connecticut Courant*, Oct. 3, 1791, could report that the manufacture after struggling with every obstacle began to flourish. "The quality of the cloths, more especially the coarser, is acknowledged on all hands to be superior to English of the same fineness. It is an undeniable fact that the coatings made here are more durable than the English. The great objection formerly made to the coloring and finishing of the cloths is now removed, it being agreed by the best judges that the difference between the best finish English cloths and those of this manufacture is hardly perceivable." The first and only dividend passed by the company was one of 50 per cent., which was declared Dec. 10, 1794.

The sale of goods was not rapid, and, as the demand seemed to be for imported fabrics, the stock accumulated so fast in the factory that it finally had to be sold at auction. The business, which had never been a commercial success, was eventually sold in 1795 at auction, and the greater part of the machinery was bought by Jeremiah Wadsworth, who for a while carried on the business. It was finally given up, and for some time previous to April 3, 1854, when the building (which stood on the bank of Little River at the foot of Mulberry Street) was burned, it was occupied by a manufacturer of soap and candles.

FIRST WOOLEN MILL OPERATED WITH POWER MACHINERY

According to Royal C. Taft, who investigated the matter, the first woolen mill that was successfully operated in the United States with power machinery was built in 1794 at the falls of the Parker River in Byfield Parish of Newburyport, under the direction of John and Arthur Scholfield, who arrived in Boston from Saddleworth, Yorkshire,

England, in May, 1793, and went to live in Charlestown, not far from Bunker Hill. Meeting Jedediah Morse, author of "Morse's Geography and Gazetteer," and telling him of their knowledge of the textile industry and the best methods of manufacturing, he became interested, and introduced them to people of wealth in Newburyport, who were desirous of starting the industry there, and by whom they were engaged to erect the mill.

Most of the machinery was built in Newburyport by Messrs. Standring, Armstrong, and Guppy. Benjamin Greenleaf, Theophilus Parsons, William Bartlett, Moses Brown, and others were incorporated as the proprietors of the Newburyport Woolen Manufactory, with a capital in real estate of ten thousand pounds and in personal estate of eighty thousand pounds, and here was constructed and operated the first carding machine for wool in America. Until the mill was ready to contain it, it was worked by hand. John Scholfield was employed as agent, and for years the business was successfully conducted, broadcloth and flannel being made. It is not known how long the mill continued in operation, but it was burned Oct. 29, 1859.

Previous to the Newburyport enterprise John Manning had in 1792 built a mill in Ipswich upon land granted by the town, in which broadcloths, blankets, and flannels were made, all the work of carding, spinning, and weaving being done by hand. The mill was a hundred and five feet long by thirty-two feet wide, two stories high, and built of wood. As it was not successful, cotton took the place of wool, but this, too, failed to pay, and finally in 1800 work stopped.

After being with the Newburyport Woolen Mill for about five years, John Scholfield in 1789 hired for fourteen years water power on the Oxoboro River in Montville, Conn., moved there, and built the first woolen mill in Connecticut, which he operated with his brother Arthur until 1806, when he sold out to John and Nathan Comstock. In this same

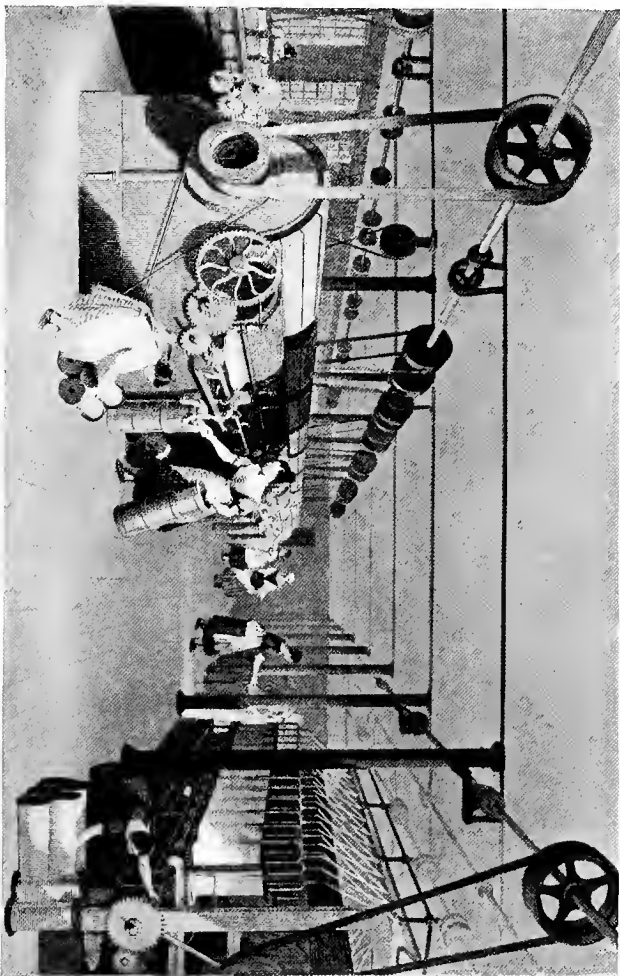

CARDING, DRAWING, AND ROVING AS IT WAS IN SAMUEL SLATER'S EARLY MILLS
(From an old engraving)

year he fitted up a factory he had bought at Stonington, Conn., and operated it.

In the mean time Arthur Scholfield, who had gone to Pittsfield in 1800, built a woolen mill there, and started operations in November, 1801; and on Nov. 2, 1801, his first advertisement appeared in the *Pittsfield Sun*, advising the people of Pittsfield that he would card their wool and sell them woolens. In 1804 John Bissell, a leading merchant of Pittsfield, who had gone to New York to buy goods, brought home two pieces of Scholfield's cloths, gray mixed broadcloth, which he had bought for imported fabrics. James Madison in 1808 was inaugurated President in a suit made from thirteen yards of black broadcloth made by John Scholfield. In 1809 Daniel Day built a mill at Uxbridge, Mass., twenty by forty feet, two stories, and put in a carding machine and picker, later adding to his mill a billy and jenny for weaving, and still later added five hand looms.

The situation in Massachusetts, Rhode Island, and Pennsylvania when Samuel Slater arrived from England in 1789 was that textile manufacturing of both cotton and wool goods in factories on a scale large enough to meet some of the domestic demand had been established, and, though not a commercial success, was making some progress. The little power machinery that was used was confined mainly to carding machines and spinning jennies,—imperfect machines which were either domestic attempts at copying the machines in use in England or crude productions of American inventors. No one had yet succeeded in water spinning, because Arkwright's machines could not be obtained from England, and, despite the inducements held out by various commercial bodies, no one had been able to make practical reproductions of the English machines. The arrival of Slater marked a new and more flourishing era in textile making.

CHAPTER VII

ERA OF SAMUEL SLATER

SLATER'S ARRIVAL IN AMERICA—GOES TO PROVIDENCE—STARTS FIRST COTTON MILL WITH ARKWRIGHT'S MACHINES IN AMERICA—PAYMENT AND DISCIPLINE OF EMPLOYEES—STARTS HIS SECOND MILL; THE FIRST WITH ARKWRIGHT MACHINERY IN MASSACHUSETTS—FIRST COMMISSION HOUSES—SHEPARD STARTS MILL AT WRENTHAM—OTHER MILLS START—WHITTENTON COTTON MILLS—START OF THE INDUSTRY IN CONNECTICUT—SPREAD OF INDUSTRY THROUGH INFLUENCE OF SLATER—GILMORE'S LOOM—BEGINNING OF POWER WOOLEN MILLS IN RHODE ISLAND—SOUTHERN DEVELOPMENT

Samuel Slater has been rightly called the father of the American cotton industry, for to him more than to any one else was due the construction and first successful operation in America of Arkwright's system of cotton machines. Before Slater came to America, all attempts to make Arkwright's machinery had been futile, despite the many inducements held out by various commercial bodies for practical Arkwright machines.

Slater was the son of a yeoman farmer in Belper, Derbyshire, where he was born June 9, 1768, and was early apprenticed to Jedediah Strutt, who was a partner of Arkwright, and had established one of the first cotton mills in Belper. He was with Strutt, who was a friend of his father, for over eight years, and later served as superintendent of Strutt's mill, so that he had a comprehensive knowledge of Arkwright's machines.

SLATER'S ARRIVAL IN AMERICA

A few months prior to November, 1789, when he arrived in New York, he read in a Philadelphia paper an account of a bounty of a hundred pounds granted by the legislature of Pennsylvania to a person who had imperfectly succeeded in constructing a carding machine to make rolls for jennies. The account also told of the offers of other State governments to encourage manufactures, and the great need in America of the proper textile machines. Pennsylvania, wishing to establish the cotton industry, had put a duty on fabrics of 10 per cent. Influenced by the pecuniary reward that America offered to one familiar with cotton spinning, Slater determined to emigrate secretly. Knowing the stringent regulations of the English government to prevent a knowledge of the textile machines spreading abroad, having fixed the designs of Arkwright's machines in his mind, he set out for America without telling even his parents of his intentions.

He had intended to go to Philadelphia, but upon his arrival he secured work with the New York Manufacturing Company. Becoming dissatisfied, however, with his prospects, and learning, from the captain of one of the Providence packets, of Mr. Moses Brown's interest in the textile business, Slater wrote to Mr. Brown, Dec. 2, 1789, that, as he had learned Mr. Brown "wanted a manager of cotton spinning, etc., in which business" he flattered himself he could give the greatest satisfaction, "in making machinery, making good yarn, either for stockings or twist, as any that is made in England," if Mr. Brown was "not provided for," he should be "glad to serve" him. He asked Mr. Brown to drop him a line "respecting the amount of encouragement" he "wished to give." Slater stated that he had "had an oversight of Sir Richard Arkwright's works," and was "in Mr. Strutt's mill upwards of eight years," and that the New York manufactory had

but one card, two machines, and two spinning jennies which were hardly worth using.

The New York manufactory was the outgrowth of "The New York Society for the Encouragement of American Manufactures," which was organized late in 1788, and made at first only linen yarns and cloth; for their advertisement read, "For sale at the factory on Vesey Street, a quantity of brown linen sheeting, linen yarn of the first quality, hatchelled flax, tow and backings."

In reply Moses Brown wrote him from Providence under date of Dec. 10, 1789, that "Almy and Brown who has the business in the cotton line," which Brown began, Almy being his son-in-law and Brown a kinsman, "did want the assistance of a person skilled in the frame or water spinning." An experiment had been made, but it had failed, as no one was acquainted with the business. "We hardly know what to say to thee, but if thou thought thou couldst perfect and conduct them to profit, if thou wilt come and do it, thou shalt have all the profit made of them over and above the interest of the money they cost, and the wear and tear of them. We will find stock and be repaid in yarn as we may agree, for six months. And this we do for the information thou can give, if fully acquainted with the business."

The letter concluded, "If thy present situation does not come up to what thou wishest, and, from thy knowledge of the business, can be ascertained of the advantages of the mills, so as to induce thee to come and work ours, and have the credit as well as advantages of perfecting the first water mill in America, we should be glad to engage thy care so long as thee can be made profitable to both and we can agree, I am for myself and Almy and Brown, thy friend, Moses Brown."

GOES TO PROVIDENCE

Moses Brown was a retired rich merchant of Providence who had long been identified with the East India trade, and had lately become interested in the cotton industry. He had purchased and installed at Pawtucket the imperfect machines of Daniel Anthony, Andrew Dexter, and Lewis Peck, and with his two relatives, William Almy and Smith Brown, was endeavoring to establish the cotton spinning.

Accordingly, Slater, Jan. 18, 1790, went to Providence and showed Mr. Brown his apprentice indenture with Mr. Strutt, and Mr. Brown took Slater to Pawtucket and showed him the machinery that had failed to work. When Slater saw the machines, he shook his head and said:—

“These will not do: they are good for nothing in their present condition, nor can they be made to answer.” It was finally proposed that Slater should build wholly new machines after the Arkwright patents, but Slater would not consent until he was promised a man to work on wood who should be put under bonds not to steal the patterns or disclose the nature of the work.

“Under my proposals,” said he, “if I do not make as good yarn as they do in England, I will have nothing for my services, but will throw the whole of what I have attempted over the border.”

Articles of partnership were drawn up April 5, 1790, between William Almy, Smith Brown, and Slater, under which they furnished the capital and Slater in return for constructing the machinery and spinning the cotton was to have one-half of the profits and own one-half of the machinery. Almy and Brown were to have $2\frac{1}{2}$ per cent. commission for the purchase of stock and 4 per cent. for selling yarn. Slater was charged one-half the expense of purchasing and constructing the machines and also for his living expenses while developing the business. The firm was to be Almy, Brown & Slater.

At the time that Slater went to Pawtucket, Almy and Brown were manufacturing billies and jennies, and had carding machines driven by men, and wove and finished jeans, fustians, thicksetts, velveret, the work being done mostly by Irish emigrants. The spinning frame shown Slater, and which he discarded, was the one that Brown had bought from Andrew Dexter and Lewis Peck. It made very poor yarn, the cotton being carded by hand and "roped on a wooden wheel by a female." Brown had also bought and installed at Pawtucket the loom with fly shuttle that Joseph Alexander and another Scotchman unsuccessfully attempted to operate in the market house at Providence.

The building in which Slater's new machines were set up was the fulling mill of Ezekiel Carpenter, and stood on the south-west abutment of the Pawtucket bridge. It was swept away by a freshet in 1807. Slater at once began to build a water frame of twenty-four spindles, two carding machines, and the drawing and roping frames necessary for the spinners, and soon after added a frame of forty-eight spindles. Great secrecy was maintained while the machinery was being made, shutters shielding the front windows and blinds covering the back windows. Sylvanus Brown cut out the parts of the spinning machines after Slater had chalked them out on the wood.

Oziel Wilkinson, the clever blacksmith of Pawtucket with whom Slater boarded and whose daughter Hannah Slater married, made with his sons, under Slater's direction, the iron-work of the machines, while Pliny Earl, of Leicester, made the cards. At first the cards would not work, and, when Slater pointed out the defect, Earl and he beat them to the proper curve with a piece of grindstone. The power was supplied at the start by a wheel propelled by an old negro, Samuel Brunius Jenks, but later water power was installed.

When Slater started his cards, the water wheel was so

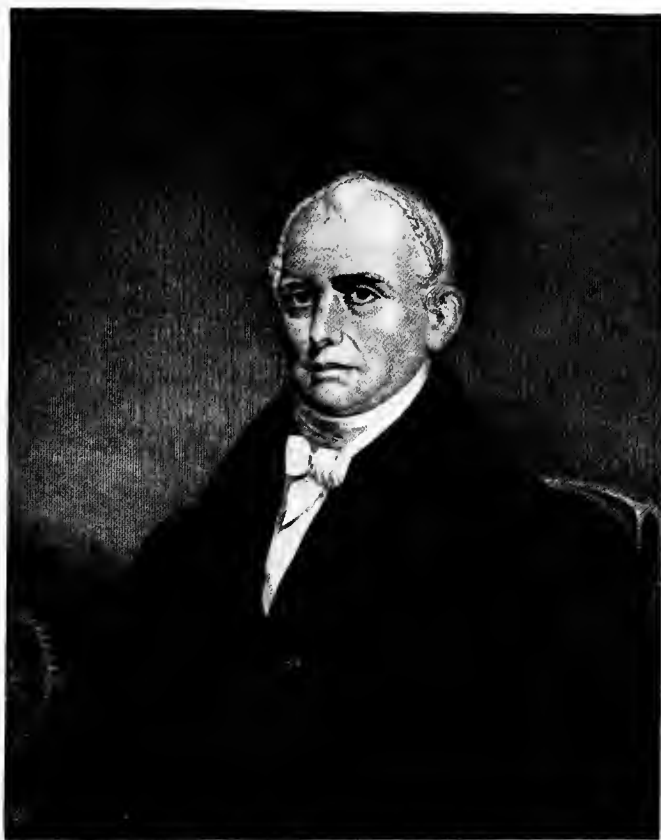

Samuel Slater

exposed that it was frozen every night, and, as he could get no one to bear the cold of the water in order to break the ice to start the wheel, he himself had to spend two or three hours before breakfast every morning doing the work.

STARTS FIRST COTTON MILL WITH ARKWRIGHT'S MACHINES
IN AMERICA

It took Slater longer than he anticipated to finish his frames, so that it was not until Dec. 20, 1790, that he started three cards, drawing and roving, and seventy-two spindles in the clothier's shop of Carpenter at Pawtucket, where the machines were set up and driven by an old fulling water wheel.

The cotton in Slater's time was laid by hand, a handful of it being taken up and pulled apart with both hands. It was shifted to the right hand to get the staple straight and to fix the handful so as to hold it firm. Then it was applied to the surface of the breaker, the hand being moved horizontally to and fro until the cotton was prepared.

Soon they had several thousand pounds of yarn on hand. The infant industry quickly felt the need of government protection, and Moses Brown wrote, April 19, 1791, to one of the proprietors of the Beverly Cotton Manufactory upon the subject of applying to Congress for some encouragement to the cotton manufacturers, to take the shape of an additional duty that could be offered as a bounty partly for sowing and raising cotton in the Southern States and partly as a bounty on cotton goods that might be manufactured.

In a letter to John Dexter, Oct. 15, 1791, Moses Brown said that, previous to Slater's arrival, Almy and Brown had been making warps of linen, and that it was more than twelve months before Slater could complete enough machinery to spin perfectly single warps of cotton. During the time that Slater was working on his machinery, lineu warps were woven, and the spinning jenny was operated

in the cellars of dwelling-houses. Finding the inconvenience of sending out the spinning, Slater and his partners erected in 1793 a new mill, called the "Old Slater Mill," and dye-shop, about forty feet long, twenty-six feet wide, two stories high, with an attic; and later, also, additions were built for singeing, calendering, and other machines. Alexander Hamilton, in his report as Secretary of the Treasury, made Dec. 5, 1791, said,—

"The manufactory at Providence has the merit of being the first in introducing into the United States the celebrated cotton mill, which not only furnishes materials for that manufactory itself but for the supply of private families, for household manufacture."

PAYMENT AND DISCIPLINE OF EMPLOYEES

According to Moses Brown the manufacturing of the mill yarn was done by children from eight to fourteen years old. Some of the first yarn spun by Slater was as fine as No. 40, and with some of the first cloth made from the warp was sent to the Secretary of the Treasury. Before Slater began manufacturing, a yard of cloth made by the wheel and loom cost fifty cents, and never less than forty cents. A few years later it could be bought for nine or ten cents.

As employees received but eighty cents to \$1.30 and \$1.40 per week, and indoor work was not alluring, it was difficult to secure the right kind of help. Slater introduced the English apprentice system, but it did not work, and was soon given up. One boy, who found the work too hard and discipline too strict, complained to a companion, who replied, "Very well, act like the devil, and Slater will lay you off."

Slater maintained a strict yet sort of paternal care over the welfare of his employees, starting in 1793 the first Sunday-school in America, and also day schools for the workmen's children. The first market for Slater's yarn

was Salem, Hartford the next, and Philadelphia the third. The first commission merchant to sell yarn was Elijah Waring. New York and Boston at first took hardly any, and much was sold at the mill.

As Slater boarded with the Wilkinson family, the women were naturally much interested in the cotton thread, and finally Hannah (Mrs. Slater) conceived the idea of twisting some fine Surinam cotton yarn Slater had spun, in place of the linen twisted yarn, on their own spinning wheels for sewing thread, and finally in 1793 made the first cotton thread made in America. A manufactory for the thread was established by the Wilkinson Brothers.

When Slater commenced his work, it was beyond the power of America to compete with English goods, but in fourteen months after Slater had perfected his machines Brown wrote the Secretary of the Treasury that machinery and mills could be erected within one year to supply the whole United States with yarn and render its importation unnecessary.

Within two years of Slater's starting to manufacture he had accumulated two thousand pounds of yarn, which so alarmed the careful and thrifty Moses Brown that he wrote Slater,—

“Thee must shut down thy gates or thee will spin all my farms into cotton yarn.”

STARTS HIS SECOND MILL; THE FIRST WITH ARKWRIGHT MACHINERY IN MASSACHUSETTS

Slater's work was successful from the outset, and in 1799 he formed a partnership with Oziel Wilkinson, his father-in-law, Timothy Green, and William Wilkinson, his brother-in-law, under the firm name of Samuel Slater & Co., and built in 1799 on the east side of the river at Pawtucket, in what was Rehoboth, Mass., the mill called the “New Mill,” also “The White Mill,” which was the

first mill to use Arkwright's machines in Massachusetts. Slater superintended both old and new mills, getting \$1.50 a day per mill, or \$3 a day salary, in addition to his share of the profits. To the north of this mill was the Bleaching Meadow where, upon stakes driven into the ground, skeins of cotton were stretched and cloth was spread upon the ground for bleaching. "Mother Cole," who managed the bleaching, and her assistants sprinkled the cotton with watering-pots.

The cotton used by Slater was from Cayenne (French Guiana), Surinam (Dutch Guiana), and Hispaniola (Hayti), and brought from ninety cents to \$1.10 per pound. The cotton was cleaned and whipped by poor families, to whom it was put out at from four to six cents per pound, according to the cleanliness of the cotton.

FIRST COMMISSION HOUSES

The production of the mills was sold through agents in Salem, Boston, New York, Philadelphia, and Baltimore, and these agents grew to be the leading commission houses in these centres. The first of these early agents, as we have learned, was Elijah Waring, of Philadelphia; and another was Jeremiah Brown, of Philadelphia, a brother of Moses Brown. Many letters exist to show the business acumen of Slater in transacting his business with these agents. A Boston newspaper in May, 1809, contained the following advertisement, which shows that as early as 1809 Slater had begun the weaving of cotton:—

"Factory Cotton and Thread Store, 26 Court Street, opposite Concert Hall. George Connell, agent for Almy and Brown, of Providence and Pawtucket Manufactories, has now for sale from eight to ten thousand weight of yarn for weaving, etc., three thousand yards of cloth, such as checks, stripes, chambrays, gingham, bed-ticks, shirting, and sheeting cotton, etc."

Up to 1789 the construction of Arkwright's machines and the operation of the mills using them had been confined to Mr. Slater and his associates, but soon after 1789 several of Slater's men left his employ and erected mills for themselves or others.

SHEPARD STARTS MILL AT WRENTHAM

One of the first cotton mills that was started through the influence of Samuel Slater was that of Benjamin Shepard, Wrentham, Mass. Shepard was a farmer. He inherited the farm on which he lived from his father, and evidently had been engaged in the homespun industry some time previous to 1792, when he erected a mill and received a loan of three hundred pounds on June 20, 1793, from the legislature to carry on his business.

The mill was built on a brook which he had dammed on his farm, and here he manufactured fustians, cotton velvets, and similar fabrics. He colored his yarns in a dye-house, and wove them on a hand loom in a weave-shop that adjoined the factory. His factory was about fifty feet in length, twenty feet in width, two stories high, and was divided into compartments convenient for carrying on the business. It contained a carding machine, run by water, two spinning jennies, one roping machine, four looms, one warping mill, accommodations for singeing cloth, one calender, operated by a horse, and had also facilities for coloring and finishing cotton cloths, and many other small machines. He could card about one hundred pounds of cotton per week, spin from seventy-two to one hundred and twenty pounds, weave one hundred and twenty yards, and color and finish the material.

His wife conducted an industry on her own account for some years, taking yarn and waste from her husband's mill and working it up into various fabrics. A quaint document is a contract made by her with Stephen Olney,

of Providence, in which he agreed to furnish her a chaise for the value of a chaise in goods of her own manufacture. The business was carried on by Shepard's sons, and subsequently came into the possession of others, and has been in operation for over one hundred years. It has probably been longer in continuous operation than any other mill in the country.

Colonel Job Green, John Allen, and others in 1794 established at Centreville, in the town of Warwick, the second cotton mill in Rhode Island. It was not successful until 1799, when one-half of the property was bought for twenty-five hundred dollars by William Almy and Obadiah Brown. Full control was secured by Almy and Brown after buying the other half in 1801, and the story goes that Brown and John Allen visited Slater's mill at Pawtucket to see how things were run there and to get some useful hints. Slater, having no interest in the Warwick mill, was not at all pleased by Allen's investigation, and, when Allen attempted to measure some of the machines, took hold of him and threatened to throw him out of the window. Obadiah, who was a partner of Slater, as well as of Allen, took the measure from Allen, saying, "I will finish thy work, and I will see if Samuel will serve me as he did thee." Slater did not care to attack his own partner. The measurements were taken, and the Warwick mill was thereby equipped with better machines.

The second cotton mill in the Rehoboth part of Pawtucket was built in 1805 by those who took the name Pawtucket Cotton and Oil Manufacturing Company. As it was of wood painted yellow, it was known as the "Yellow Mill" to distinguish it from the "White Mill" of Samuel Slater & Co. just above it, and the "Green Mill" of Almy, Brown & Slater across the river. It started in the fall of 1805, and its business was so remunerative that its owners built a mill called the "Stone Mill" in 1823.



MOSES BROWN

OTHER MILLS START

Benjamin S. Walcott, who had worked on the construction of Slater's first mill, with Rufus and Elisha Waterman erected a mill at Cumberland, R.I., in 1802. Another workman, Charles Robbins, built the first mill for cotton manufacturing in New Hampshire at New Ipswich, on the Souhegan River, and it started on Dec. 15, 1804, four and one-half pounds of yarn being spun, which sold for \$3.42. The original proprietors of this first mill were Charles Barrett and Robbins. Daniel Brooks, who had been employed in the mill at New Ipswich, N.H., erected in 1807 the second cotton mill in New Hampshire, a short distance below the first mill. It subsequently came into the hands of Seth Mason, Jesse Holbin, and Samuel Batchelder. These two, the first cotton mills in New Hampshire, contained about five hundred spindles each.

Another employee at one of the first Pawtucket mills, B. S. Walcott, Jr., with his father erected the first cotton mill in Oneida County, New York, near Utica, in 1807 or 1808. Within three years of Slater's completion of his first mill in 1791, ten mills were completed or being completed in Rhode Island, and one in Connecticut, and before 1808 fifteen mills altogether had been put in operation, using in all about eight thousand spindles. By 1809 eighty-seven mills had been erected, using thirty-one thousand spindles.

The first cotton mill near Boston to use Slater's system, and the second one in Massachusetts, was a small mill in Beverly on the Bass River, which was opened in 1801 or early in 1802. It had six water frames of seventy-two spindles each, which had been built at Paterson, N.J., by a mechanic named Clark, who went to Beverly to install the machines. A lack of water power and other causes rendered the venture unsuccessful.

WHITTENTON COTTON MILLS

The Whittenton Cotton Mills at Taunton, of which Lawrence & Co. are the agents, was also started at the beginning of the nineteenth century. The mills are an offshoot of the Colonial Iron Works established there in 1653 by James Leonard, Sr. Iron had been discovered on the flats about Two Mile River and other localities near Taunton, and in 1652 James and Henry Leonard, of Braintree, entered into an agreement with the town of Taunton to set up iron works there. James Leonard went to Taunton and established the iron works in 1653, and for twelve years was the foreman in charge of the industry.

He subsequently bought ten acres of land with a water privilege on Two Mile River, built a forge which he called the Whittington Forge, and obtained permission to build a dam and flow a neighbor's land. At his death he left the Whittington Iron Works to his three sons. The grist-mill part of the interest, which had been erected on the land of the iron works, was sold in 1810 to Samuel Crocker, Thomas Bush, and Charles Richmond, who had been clerks in the iron business at Whittington.

They built a nail mill, and in 1807 added a story to the nail mill for machines to spin cotton yarn that the farmers' wives wove into cloth by domestic labor. The Whittington Nail and Yarn Mill was burned down in 1811, and a cotton mill was erected on the site from the trees which two months before had been growing on the timber lot of the tract.

Crocker and Richmond after the death of Bush in 1817 imported patterns of Slater's power loom and made the first good cotton cloth about Taunton. This cotton interest was incorporated January, 1823, in the Taunton Manufacturing Company, of which Samuel Crocker, Charles Richmond, and others were the incorporators. The incorporation was for two hundred thousand dollars in real

property and four hundred thousand dollars in personal property, and was for the purpose of rolling copper and iron and manufacturing cotton and wool. Among the real estate was the Whittenton Cotton Mill and the Nail Works.

In 1835 James K. Mills & Co., who had been associated with the original incorporators, withdrew, taking as the company's share the Whittenton Mills, the "g" having been dropped in the name of the mill and the "i" changed to an "e." The mills failed in 1857, and the business in 1858 was bought by Willard Lovering. In 1880 it was incorporated for six hundred thousand dollars, with William C. Lovering, president, Charles L. Lovering, treasurer, Henry M. Lovering, agent and clerk, since which time it has been in prosperous operation.

START OF THE INDUSTRY IN CONNECTICUT

An early effort to spin cotton was made in 1790 at Norwich, Conn., by Lathrop and Eells. The beginning of the textile industry in Norwich goes back to 1766, when Christopher Leffingwell commenced stocking weaving with William Russell, an Englishman, the first operator. For a time it was a small concern, working but two or three looms, but by 1791 nine looms were producing from twelve hundred to fifteen hundred pairs of hose made from worsted, cotton, linen, or silk, the silk hose selling from twelve to twenty shillings per pair. Gloves and purses were also made, five workmen being employed.

The business was later carried on by Jeremiah Griffing, and from Norwich the stocking industry spread in 1790 to Poughkeepsie, N.Y., Hartford, New Haven, Litchfield, and Wallingford, Conn., where stocking looms similar to those that were used in Norwich were employed.

This industry attracted the attention of Joshua Lathrop, who with his brother conducted a retail and wholesale general store in Norwich. He engaged in 1790 a man

named Herrick, who had been employed in the cotton factory in Beverly, to come to Norwich and start cotton manufacturing.

It is not known whether the machines were imported or made from the crude models that were used at Beverly. A building was erected, and one carding machine, six spinning jennies, and six looms like those in the cotton factory at Beverly were installed. Machines were added, and fabrics to the amount of about two thousand yards per year were being turned out.

An advertisement which appeared March 19, 1783, stated:—

“Lathrop and Eells have just finished a variety of cotton goods consisting of Royal Ribs, Ribdeclures, Ribdurants, Ribdenims, Ribbets, Zebrays, Satinetsts, Satin-stripes, Satincords, Thicksetts, Corduroys, Stockinetts, Dimotys, Feathered Stripes, Bird’s-eye, Denims, Jeans, Jeanetts, Fustians, Bed Tickings, that will hold feathers. The above goods are well finished, and for durability undoubtedly superior to European manufacture. Gentleman Merchants, and others, who feel disposed to encourage home manufactures, are invited to call and see for themselves, and may be assured they will be supplied as low as they can furnish themselves from any quarter.”

Although ample capital was back of the business, it could not be made profitable, and the business was not long continued.

SPREAD OF INDUSTRY THROUGH INFLUENCE OF SLATER

The arrival of John Slater, a younger brother of Samuel, from England in 1803, who had been urged by his older brother to come to this country and engage in business with him, led to the erection at Smithfield, now called Slatersville, in 1807 of the mills which John Slater managed. John, who had been apprenticed to the trade of a

millwright, had a thorough knowledge of mill construction in England, and furthermore was advised by his brother Samuel to visit, before sailing for this country, Manchester and Oldham to secure knowledge of the latest improvements in English machinery. This John did, so that, when he arrived here, he had a knowledge of Samuel Crompton's mule, which had been invented in 1779, but of which Samuel Slater knew nothing, so slow were the English mills to adopt the mule at the time that Samuel Slater left England.

John Slater entered the employment of Almy, Brown & Slater at Pawtucket, and, when it was decided in 1805 to begin cotton manufacturing in a new place, John Slater set out on a horseback journey to locate a site. He rode through the wilderness in the northern part of the town of Smithfield, and coming to a stream called by the Indians the Monhegan River, which was the southern branch of the Blackstone River, saw at once that water power possessed great possibilities. At one place it fell about forty feet from a series of natural reservoirs, which gave promise of water even in a dry season.

Sufficient land was bought to control the water power, and a partnership was formed by William Almy, Obadiah Brown, Samuel Slater, and John Slater, under the name of Almy, Brown & Slaters. The mill was completed in 1806, and spinning was begun early in 1807. The locality in which the mill was built is now called Slatersville.

GILMORE'S LOOM

It was to John Slater that William Gilmore presented his plans for building a loom. Gilmore had arrived in Boston in 1815, and, knowing how to build power looms and dressing machines, was advised to apply to the Slaters. He went to them, and offered to build machinery for power loom weaving, with the understanding that he was to re-

ceive nothing, should he be unable to put the looms into successful operation.

The conservatism of Samuel Slater could not be overcome, and the proposal was therefore turned down, although John Slater was in favor of the proposition. Had Samuel Slater accepted the proposal, he would have been the first not only to have introduced into Rhode Island cotton spinning, but also power loom weaving.

Gilmore, after being employed for a while in the machine shop of the factory at Slatersville, went to the Lyman Cotton Manufacturing Company, which had been started early in 1810 by Judge Daniel Lyman at North Providence, R.I., and made the same proposal to Judge Lyman that he had made to the Slaters. Gilmore's offer was accepted, so that the Scotch loom, which was invented by William Horrocks, of Stockport, England, during the years from 1805 to 1813, was first introduced into Rhode Island by Judge Daniel Lyman and Gilmore.

This loom differed from the Waltham loom of Francis C. Lowell, who introduced the latter into the mills of the Boston Manufacturing Company at Waltham, Mass., in this respect: in Gilmore's loom the lift and fall of the harness were accomplished by a crank, while in the Waltham loom the work was done by a cam. Then, too, it cost but seventy dollars to build a Gilmore loom, while the Waltham loom cost almost three hundred dollars. Judge Lyman did not restrict the use of the loom in any way by patenting it, but permitted Mr. Gilmore to sell to David Wilkinson for ten dollars the use of all his drawings, so that it was not long before the Scotch loom, as the Gilmore loom was known, was being used quite generally by the mills in the lower part of New England, looms being built by David Wilkinson and others.

The first mill to use steam was erected by Mr. Slater and his assistants in 1827 at Providence, and it was run with anthracite coal from the Schuylkill, producing yarn

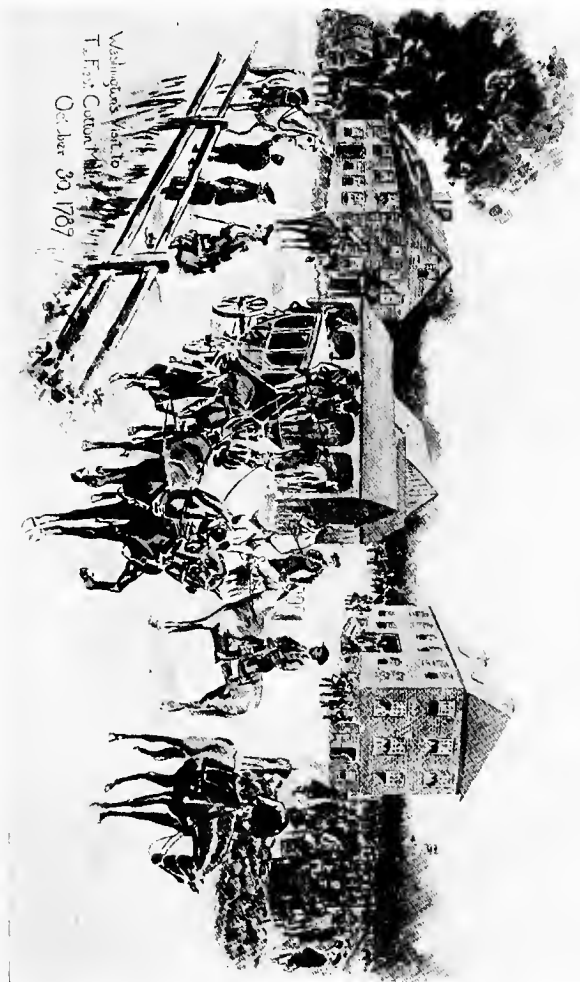

Washington's Visit to
T. Fane Cotton Mill
October 30, 1789

WASHINGTON'S VISIT TO THE FIRST COTTON MILL, AT BEVERLY, MASS., OCTOBER 30, 1789
(From an imaginary sketch in possession of Robert S. Rantoul)

No. 80, the cloth of which was said to be the finest in the country.

Slater's successful use of Arkwright's machines not only brought him and his associates great prosperity, but placed cotton manufacturing in the United States on a secure footing. By this time Slater had become interested in wool as well as cotton, and was the leading textile manufacturer of his era. The War of 1812 greatly increased his prosperity, as cotton cloth sold at forty cents a yard and the demand was unlimited.

Societies sprang up in most of the States to encourage manufacture, and Congress passed acts protecting the infant industry against foreign competition. By 1805 the total consumption of cotton in the United States was little more than 1,000 bales: in 1816 90,000 bales of cotton were used. In 1805 the mills of the United States could not furnish the army with 6,000 blankets: in 1816 there were \$40,000,000 invested in cotton manufacture and \$12,000,000 in woolen. In the same year the whole amount of goods made in the United States was \$50,000,000 or \$60,000,000: by 1836 \$250,000,000 was made, of which \$25,000,000 was exported.

Mills continued to increase rapidly, so that by the opening of the war with Great Britain in 1812 there were in Rhode Island thirty-three factories using 30,663 spindles and twenty factories in Massachusetts using 17,371 spindles, or fifty-three factories with 48,034 spindles in all. Each spindle produced enough yarn weekly to make $2\frac{1}{2}$ yards of cloth of a value then of about thirty cents a yard, or in all 128,635 yards of cloth, worth \$96,476.

The effect of Slater's influence on the woolen industry was soon seen in Rhode Island, where a number of attempts were made prior to 1800 to card and spin wool by power. At the time of Slater's death in 1835 the American textile industry was firmly established.

BEGINNING OF POWER WOOLEN MILLS IN RHODE ISLAND

The history of the starting of the woolen industry in Rhode Island on a scale worthy of being called manufacturing compasses the story of the business ability and foresight of Rowland Hazard. An attempt to card wool by water power had been made in 1800 by one Irvin, an Englishman, but it was a failure, and it was not until Mr. Hazard appeared that it was carried to success.

Mr. Hazard had been a commission merchant and importer in Charleston, and had married Mary Peace, the daughter of Isaac Peace, a wealthy merchant there. He bought in 1802 from John Warner Knowles one-half of a ten-acre property, including a mill privilege, dam, and a fulling mill which Benjamin Rodman had built a number of years before. Benjamin Rodman, who had inherited a mill privilege and saw-mill on Rocky Brook, a tributary of the Saugatuck River, from his father about 1790, built a fulling mill on the land, and it was conveyed with the ten acres in 1802 to his grandson, the aforesaid John Warner. Here Messrs. Knowles and Hazard commenced fulling and dressing cloth, and in 1803 wool carding was added to the industry. Later Joseph Congdon became one of the partners.

About 1808 Mr. Hazard, who had closed out his business in the South, commenced the weaving of cloth, employing the hand looms in the homes of his neighborhood. At first the fabric was a sort of linsey-woolsey, but had a warp of cotton. It was largely used for women's garments or for men's summer wear. The business grew, and Mr. Hazard in 1814 contracted with Thomas R. Williams to set up four looms of his own make. It is said that those were probably the first power looms successfully operated in America. It is also said that Mr. Hazard was the first one in this country to employ water power to operate the spinning jenny. Mr. Hazard finally retired, and the business was

carried on with great success by his enterprising sons and their children under the name of the Peace Dale Manufacturing Company, so called from that part of South Kingston which had been known for three-quarters of a century as Peace Dale, and was probably named from Mary Peace, the first Mrs. Hazard.

The stimulating effect of the growth of the cotton industry was further seen in the establishment in 1814 of the Lynn Linen Spinning Factory Company, which purposed to do for linen what had already been done for cotton. A factory of wood, three stories high, was erected on the east side of the Saugus River, and the manufacture of sail duck was completed. This factory was quite prosperous until the end of the War of 1812, when the large importation of linen forced it out of business.

Another attempt was made in 1816 by Nathaniel Perry, who built a dam over the brook in North Saugus, and erected a large wooden building to spin and weave a finer kind of linen; but this, too, was a failure.

SOUTHERN DEVELOPMENT

The spinning and weaving of cotton began in a desultory way in the South soon after it was found that cotton was a profitable crop and the growing commenced on a commercial scale, but home spinning and weaving of cotton for domestic use was early universal in the South. Thomas Jefferson speaks of employing in his household two spinning jennies, a carding machine, and a loom with a flying shuttle, by which he made the more than two thousand yards of cloth which his family and servants required yearly. In a letter written by him in 1786 we have learned that he wrote: "The four southernmost states make a great deal of cotton. Their poor are almost entirely clothed in it in winter and summer. It is as well manufactured as the calicoes of Europe."

The first cotton mill in South Carolina, as far as can be ascertained, was started by horse-power in 1787 on James Island, near Charleston. It is said to have contained eighty-four spindles and to have been first driven by horse-power. One of the earliest developments of manufacturing in the South was in Baltimore, Md., and was the outgrowth of a meeting of tradesmen, manufacturers, and others that was held Feb. 24, 1789, at which a petition to the United States Congress was presented. This petition recited that America was now freed from the commercial shackles which had long bound her and could become independent in fact as well as in name. The petitioners therefore hoped that the encouragement of American manufactures would receive the early attention of the Supreme Legislature of the land, as the United States had resources amply sufficient to enable them to become a great manufacturing country. The petitioners hoped, in conclusion, that the Supreme Legislature would place such duties on all foreign articles that can be made in America as will give a just and decided preference to domestic goods.

On May 2, 1789, a meeting of citizens was held at Stark's Tavern, Baltimore, for the purpose of establishing a cotton manufactory. A committee was appointed, which led to the organization of the Baltimore Manufacturing Company with a capital of ten thousand pounds, divided into a hundred shares of a hundred pounds each. A meeting was held on June 3, at which directors were elected and advertisements prepared for looms, spinning wheels, check wheels, etc., and for skilled manufacturers of cotton, flax, and wool. Joseph Low seems to have been made manager, for he subsequently advertised for weavers, and directed applicants, who would receive liberal wages, to apply at the factory, where a few women could be set to work winding yarn.

The last reference to this manufacturing company is on April 1, 1791, when an advertisement of the directors' meeting appeared in the *Maryland Journal*. It is thought

that the industry was not carried on with any great success, for no subsequent records of it have been found.

A later attempt was made at Elkton, Md., when the Cecil Manufacturing Company, the first mill for the manufacturing of woolen fabrics in Maryland, began business in 1795. The first industry in Baltimore had been confined to cotton goods, although the original resolutions spoke as if woolen as well as cotton goods were contemplated. The chief promoter of the Cecil Manufacturing Company was Colonel Henry Hollingsworth, of Elkton, Md., who purchased on July 31, 1794, ten acres of land on both sides of the Little Elk River, and organized the company about Nov. 1, 1794.

A factory of stone, sixty feet long, thirty-six feet wide, and three stories high, was constructed, and machinery installed that was imported from Europe. The mill was burned in 1796, and a new mill was immediately built. Five hundred and ninety-five acres of land adjoining the site of the property were subsequently purchased for pasturing sheep to supply the mill with wool, and in 1805 John Wilson, of Yorkshire, England, was engaged as manager. So excellent were the goods that cloth was made into a suit of clothes that was worn by President Jefferson at his inauguration. The enterprise was undoubtedly a success, and was carried on for a number of years. At the close of the War of 1812 the immense influx of foreign goods stopped its wheels, and for a long while the property remained idle. It was finally used as a paper mill, but was burned to the ground Jan. 9, 1853.

One of the most unique organizations for the encouraging of American industries was that organized by a number of gentlemen on the 17th of January, 1789, at Wilmington, Del. The organization was called the Delaware System for the Encouragement and Promotion of the Manufactories of the United States. The members agreed to appear annually on the first of the year in a full and

complete suit of American manufacture, to encourage the raising of sheep and the growth of hemp and flax, to discourage the importation of foreign articles, and always to give preference to American manufactures where there was a reasonable proportion between the price and the quality. Other organizations, as we have seen, were established in other centres, but none was quite so specific in its articles of incorporation as this.

A cotton mill was started in Wilmington, Del., by Jacob Broome in 1795, and six small horse-power mills for the spinning of cotton were started in 1809 in Kentucky. A water-power mill was put in operation the same year in Petersburg, Va., also at Nashville, Tenn., but the real development of cotton spinning in the South has been largely since the Civil War.

The cotton for the spinning process was prepared by the farm laborers, who picked the seed from the lint by hand, and it was not until the invention of Whitney's saw-gin in 1793 that cotton growing was materially increased. We have already learned how it started in the South in the story of cotton. The rapid development of the cotton growth after the invention of the gin is seen from the fact that in 1790 two million pounds were grown in the South; in 1796, ten million; in 1810, eighty million; and in 1820, one hundred and sixty million. By 1840 cotton production had so largely exceeded the consumption that the prices became very low, and in 1844 reached an average of 5.63 cents. At the beginning of the Civil War the South by means of cotton, which had become the staple product, had reached a degree of prosperity when its property valuation was \$5,200,000,000, or $43\frac{1}{3}$ per cent. of the total property valuation of the country, which was \$12,000,000,000. The Civil War and the subsequent blockade of the Southern ports cut down the supply of raw cotton enormously and ruined the South. The planters were bankrupt, and many ended their year in debt to their factors, only the most



Francis C. Lowell.
DIED 1817.

(Courtesy of C. J. H. Woodbury)

The only likeness extant of Francis C. Lowell. This silhouette was found back of a picture in the office of the Boston Manufacturing Company, at Waltham, Massachusetts, by the late A. M. Goodale, who was long the agent of the company.

skilful farmers being able to work their way to a better financial condition.

Little by little cotton spinning began to establish itself in the South, and by 1880 had reached a point where the Southern mills were using 12 per cent. of the total amount consumed in the country, and in 1910 the amount consumed was 45 per cent. To-day the South practically controls the trade with China in cheap goods from this country.

Much of the Southern industry owes its development to New England capital, for many of the foresighted New England merchants, seeing the possibility of Southern mill development, invested their money in the promotion and erection of Southern mills.

CHAPTER VIII

ERA OF LOWELL, APPLETON, MOODY, JACKSON, AND BOOTT

FIRST COMPLETE COTTON MILL IN THE WORLD—LOWELL VISITS ENGLISH MILLS—ORGANIZATION OF THE BOSTON MANUFACTURING COMPANY—CARE OF EMPLOYEES—SALE OF GOODS—WALTHAM *versus* RHODE ISLAND SYSTEM OF MANUFACTURING—THE FOUNDATION OF THE CITY OF LOWELL AND THE STARTING OF THE MERRIMAC MANUFACTURING COMPANY—NAMING OF LOWELL—STARTING OF FIRST MILLS

The first mill in the world where the whole process of cotton manufacturing, from spinning to weaving, was carried on by power, was that of the Boston Manufacturing Company, which was incorporated Feb. 23, 1813, with a capital of four hundred thousand dollars and was erected later the same year at Waltham, from whence it took its better-known name of "The Waltham Company." The enterprise was the conception of Francis Cabot Lowell and Patrick Tracy Jackson, and it grew from investigations of textile manufacturing which Lowell had made in England.

Previous to the starting of the Waltham mill the processes of spinning and weaving were carried on in separate establishments in both England and America, those who wove buying their twist of those who spun. It was the original purpose of Lowell and his associates to construct a weaving mill to do solely by power what had previously been done by hand, but it was learned that it would be cheaper to spin the twist rather than buy it, and accordingly the mill was built with about seventeen hundred spindles.

LOWELL VISITS ENGLISH MILLS

Francis Cabot Lowell, a Boston merchant, who was born in Newburyport on April 7, 1775, and was graduated at Harvard in 1793, while visiting England and Scotland with his family in 1811, met at Edinburgh Nathan Appleton, and told him that he thought the cotton manufacturing then monopolized by England might well be carried on in America. He further informed Appleton that he had determined, before returning to America, to visit Manchester and obtain all the information to be had on the cotton machinery. Appleton urged him to do so, and promised his co-operation.

When Lowell returned to America in 1813, he had succeeded not only in seeing the closely guarded machines, but in getting a sufficiently clear idea of their construction to carry back to America the ability to make them. He talked over American conditions with Patrick Tracy Jackson, his brother-in-law, another prosperous Boston merchant, and the latter consented to engage in the enterprise with him.

Not only was machinery taking the place of manual labor in spinning, but Lowell knew that power looms had been introduced, although he had been unable to secure any accurate knowledge of these particular machines, owing to the secrecy which surrounded them. Skill and reputation, cheapness of labor and abundance of capital, were the advantages of the English manufacturer; but in favor of New England was the great abundance of superior water power and the opportunity to get raw material cheaper because of the nearness to the source of the cotton supply. It was also believed that the educational and moral superiority of the New England population and its enterprise would aid in the overcoming of English competition.

ORGANIZATION OF THE BOSTON MANUFACTURING COMPANY

With these thoughts in mind Mr. Lowell and Mr. Jackson bought the water power rights at Waltham, of John Boies' Paper Mill, and incorporated in 1813 the Boston Manufacturing Company, otherwise known as the Waltham Company, of which Mr. Jackson agreed to assume the management. Under the company's charter the authorized capital was four hundred thousand dollars, but only a hundred thousand dollars were to be raised until the experiment had been made. Most of the stock was taken by Mr. Lowell and Mr. Jackson and their friends. Mr. Appleton took five thousand dollars' worth.

As the war with England precluded communication with that country and no designs or models of looms could be procured, Mr. Lowell set about inventing a power loom, aided by Paul Moody, an expert mechanic of Amesbury. For months Lowell carried on experiments in a store on Broad Street, Boston, employing a man to turn a crank. A practical loom was completed and installed in the fall of 1814 in the new mill which had recently been completed at Waltham. The first mill was of brick, five stories high, ninety feet long, forty-five feet wide, had a roof of double pitch, known as the "factory" roof, which was trussed and braced to be very strong. It contained three thousand spindles, and turned out goods at the rate of four thousand yards per week.

According to Hurd's History of Middlesex County, the first record of the work of the Waltham mill is on the books of the company under date of Feb. 2, 1816, at which time the entry was made of "1242 yards, 4-4, or thirty-six inch wide cotton." So that this entry probably records the earliest date when the first cotton cloth was made in the world by power and the whole manufacturing process was under one roof.

The loom invented by Mr. Lowell was different from the

English loom that afterward became public in that the principal movement was by a cone revolving with an eccentric motion, that has given place to the crank motion. The power loom necessitated changes in the spinning process, particularly in sizing the warp. Drawings of Horrocks's dressing machine were secured from England, and a machine with improvements was made and installed at Waltham. To meet the need for winding the threads from the bobbins on to the beam, Mr. Moody invented the ingenious warper. Imperative necessity for a bobbin and fly, or jack, frame, arose for spinning roving, and Mr. Moody and Mr. Lowell invented the double speeder, which required the most careful mathematical calculations, and these Mr. Lowell could supply. William Bowditch, the mathematician, who was called into the patent litigation on the speeder, expressed great surprise that there was any one in the country except himself able to do the complex mathematical problems that the speeder entailed. Later, to overcome the great waste and expense in winding the thread for filling, or weft, from the bobbin on to the quills for the shuttle, Mr. Moody worked out the filling throstle.

The wooden rollers used in the first construction of the dressing frame had so swollen and warped, owing to the wool being constantly wet, that the rolls would not fit accurately, and the rollers were covered with metal by casting a coating of pewter on the outside, but these were also found impractical, owing to the difficulty of casting them. Moody at last thought of making a mould of soapstone in which to cast them, and his brother, to whom he told his trouble, said that he thought soapstone would make a very good roller, and Moody tried it and found it worked perfectly. All of which shows how much American textile manufacturers owe to Lowell and Moody, for most of their machines with improvements are in use to-day.

In Mr. Lowell's search for the best machines, accompanied by Mr. Moody, he visited a machinist named Shepard, of

Taunton, who had a patent for winding machines which were thought to be the best on the market, but Shepard refused to reduce his price, even though Mr. Lowell used them on a large scale.

"You must have them, you cannot do without them, as you know, Mr. Moody."

"I was just thinking that I can spin the caps direct upon the bobbins," said Mr. Moody.

"You be hanged!" said Mr. Shepard. "Well, I will accept your offer."

"No, it's too late," interposed Mr. Lowell, and he withdrew the offer, deciding to spin the caps upon the bobbins.

The Waltham enterprise was a success from the start, and the needs soon required raising the full capital, four hundred thousand dollars, and the addition of two hundred thousand dollars for buying a place below Watertown.

CARE OF EMPLOYEES

Under Mr. Jackson's management much attention was given to the physical and moral care of the employees. Payment of regular wages at stated intervals was begun at the outset, and boarding-houses, at the head of which matrons of good character were placed, were built at the expense of the company. No boarders were taken except operatives, and the careful regulation of these boarding-houses so gained the confidence of the surrounding population that parents were not afraid to trust their daughters to work in the factory. Pains were also taken to have as agents and overseers men of character, so that the class of help was of the best, and that aided much in the production of good fabrics.

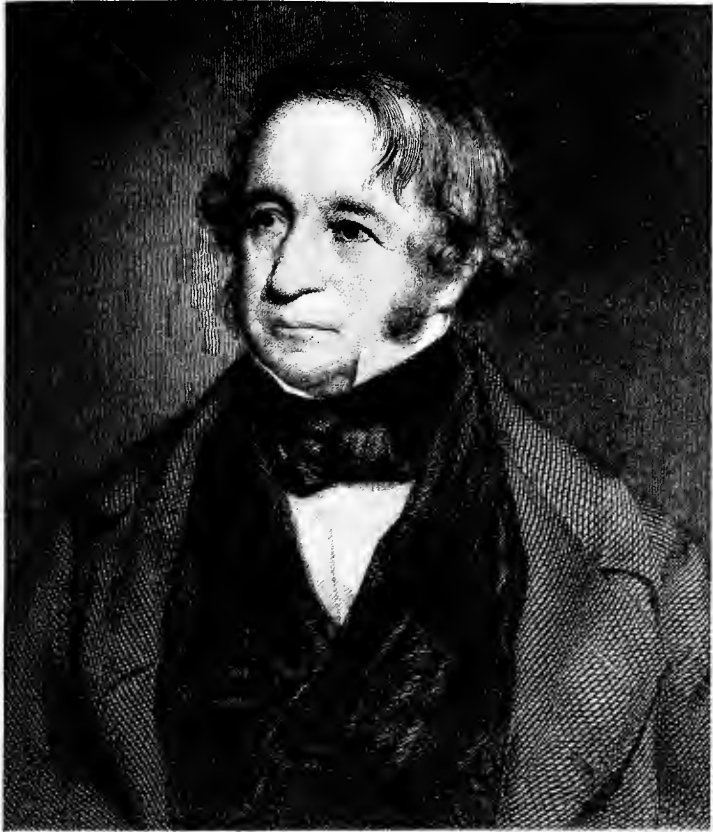

Yours truly,
R. W. Johnson

SALE OF GOODS

At first the goods did not sell very rapidly, but, as there was but one loom, they did not accumulate fast. At the outset they were sold at a shop on Cornhill, Boston, kept by the wife of Isaac Bowers, who had the only place in Boston where domestic goods were sold. Mr. Lowell and Mr. Appleton had a talk with Mrs. Bowers, who said that, although every one praised the goods and none objected to the price, yet they did not sell. Mr. Appleton, who after the peace of 1815 had entered into partnership with Benjamin C. Ward to import British goods, suggested that Mr. Lowell send the next batch of goods to the store of B. C. Ward & Co., and he would see what could be done. The goods then made at Waltham were heavy sheetings of No. 14 yarn, 37 inches wide, 44 picks to the inch, and ran about three yards to the pound, the purpose being to imitate the unbleached yard-wide goods of India, which then crowded the market. Ward & Co. found a purchaser in Mr. Forsaith, an auctioneer, who sold the product at a little over thirty cents per yard, although Mr. Lowell had said he would be satisfied with twenty-five cents. The goods continued to sell at little variation in price.

These circumstances led to Ward & Co. becoming the permanent selling agents of the company, and this was the beginning of the very successful system of merchandising so generally employed to-day.

While the War of 1812 had a marked effect on stimulating the production of American textiles, its conclusion, owing to the influx of foreign goods which were sold almost at cost, was ruinous to the industry, especially as the power loom was not in use save in Waltham. Protection was sought from Congress, which in 1816, under the influence of Mr. Lowell who went to Washington, passed a duty of $6\frac{1}{4}$ cents per square yard.

While the tariff was under discussion, Mr. Lowell visited

Pawtucket, and found all the spindles idle and the manufacturers despondent. They told him they had been so busy turning out goods at a high profit during the war that they had given no thought to improving the machinery, considering only how quickly the goods could be made. Mr. Lowell informed them that the power loom would put a new face on the situation, but the mill owners were at first incredulous, though they soon came to his opinion and began installing the looms. Mr. Lowell was also the first person systematically to arrange the processes of manufacturing in a mill so that no labor would be lost in passing from one process to another, and few changes have been made in these arrangements since he first established them.

To his fertile brain the industry owes the mill organization of the present day, with a president as chairman of the board of directors and the treasurer as the executive head, with the responsibility of buying the raw material and through the selling house disposing of the finished product, which he initiated in the Waltham mills. The subdivisions of the departments of the mill under overseers, supervised by a superintendent who had charge of the help and their operations, while a master machinist had charge of the buildings and the machinery, both reporting to the agent for the proprietors, whose functions were those of general manager, is the type of organization which Lowell instituted, and which has continued to-day as the best method of operating a textile mill and selling its products.

WALTHAM *versus* RHODE ISLAND SYSTEM OF MANUFACTURING

As mule spinning had already been introduced in Rhode Island, the power loom and other machinery of William Gilmore, who, we have learned, perfected the loom which the Lyman Cotton Manufactory had adopted at Providence, completed the Rhode Island manufacturing system, so

that within three years of the operation of the power loom at Waltham, Rhode Island was also performing all its processes by machinery. But the improvements at Waltham having been patented and their use held at a high price, most of the mills built in Rhode Island adopted the crank loom, and instead of the patented speeder used the tube speeder invented by Danforth. As many of the mills in Massachusetts and New Hampshire adopted the Waltham machinery, two methods or systems of manufacturing sprang up, one called the Waltham and the other the Rhode Island system. In one the live spindle is used, in the other the dead spindle; one uses the mule for filling, the other the filling frame; in one case the crank loom is employed, while in the other it is the cam loom. One uses the Scotch dresser, the other the Waltham dresser, and many manufacturers are still undecided which is the best. Mule spinning was not introduced into the Waltham system until after 1830. The crank loom, however, came into use in Waltham about ten years after the crank loom had been installed in Rhode Island. The great difference which existed between the two systems of machinery was that that installed at Waltham was the work of ingenious merchants, who, having little knowledge of practical manufacturing, were guided more by the facility of making the machine than by its fitness for the use intended; while the system adopted in Rhode Island was adapted to its purpose by the practical knowledge gained in English factories.

Besides this difference in machinery there was a striking divergence in the method of treating the employees. In Slater's mills, which set the pattern for Rhode Island, the English plan of employing whole families, including children who were very young, was adopted, and it led to the bringing of families into the industrial centres that were wholly dependent upon the mills and that suffered severely when there was no work. Payments, too, were made in

goods supplied at a factory store instead of the cash method followed at Waltham. At Waltham wages were paid every week or two weeks, and boarding-houses in charge of a matron were provided for the employees, the conditions of which precluded the work of children or militated against the employment of whole families.

THE FOUNDATION OF THE CITY OF LOWELL AND THE STARTING OF THE MERRIMAC MANUFACTURING COMPANY

Although the cotton industry suffered from a marked depression from 1817-20, owing to the effect of the War of 1812, the factories at Waltham during this period had been uniformly successful, paying a dividend of 12 per cent. annually. The success of the Waltham enterprise caused Lowell, Jackson, and Appleton to turn their attention to establishing another mill at a place where there would be greater water facilities, and as early as 1820 they began inquiries for a suitable site.

The falls of the Souhegan River near its junction with the Merrimac were first examined, but it was decided the power would not do. A few days later Paul Moody accompanied his wife to Bradford to visit a daughter who was at school there and incidentally to meet some gentlemen and to examine the water power. It happened to rain, and the gentlemen did not appear, so Moody rode on to Amesbury, where he met Ezra Worthen, a mechanic who worked with him at Waltham.

"Why don't you go to the Pawtucket Falls?" said Worthen, when told what Moody was searching for. "There is a power there worth ten times as much as you will find anywhere."

Accompanied by Worthen, Moody went to Chelmsford and saw the Pawtucket Falls, where Lowell now is, and reported to Jackson and the others that the falls at Pawtucket would give the whole power of the Merrimac with

a fall of over thirty feet. Jackson and Kirk Boott, an Englishman who had consented to take the management of the projected enterprise, examined the site, and, deciding that it was advantageous, steps were quickly taken to secure the stock of the canal and to obtain sufficient land to control the water power. Boott had long been familiar with the territory, as he was in the habit of hunting over it, and he and Thomas M. Clark, agent of the Canal Company at Newburyport, were empowered to buy property.

The territory of Lowell comprised in 1821 about four square miles and had fifteen hundred inhabitants, mainly farmers, who lived by cultivation of the rough fields and by fishing the Concord and the Merrimac, which meet here in the towns of Chelmsford and Dracut; and from its situation at the junction of the two rivers the site was originally called Chelmsford Neck, or, by the Indians, Wamaset. Clark and Boott succeeded in acquiring about four hundred acres at about a hundred dollars per acre, acquiring for about forty thousand dollars land which sold later for a dollar per square foot.

It is said that Boott represented to the farmers that he wanted to raise wool and fruit, and, when they learned how they had sold valuable mill privileges for a song, their rage was furious, and found expression in a song which everybody sang:—

“There came a young man from the old countree,
The Merrimac River he happened to see.
‘What a capital place for mills!’ quoth he,
Ri-toot, ri-toot, ri-toot.”

Another verse related how Boott persuaded the shrewd Yankee farmers to sell their water power for nothing, and it continued,—

“And then these farmers so cute
They gave all their lands and their timbers to Boott,
Ri-toot, ri-toot, ri-toot.”

Boott was of strong English leaning, and on one Fourth of July raised the English flag above the stars and stripes and would not take it down. A mob gathered, and pulled it down. He was born in Boston in 1791, had studied at Rugby, England, and for a time was a student at Harvard. He served as an officer in the English army in the Peninsula campaign under Wellington, and at the siege of San Sebastian in 1813 he commanded with great bravery a detachment of troops. After his resignation from the army in 1817, he returned to Boston, where he engaged in business, spending much of his spare time shooting and fishing in the towns of Chelmsford and Dracut.

Boott's part in the establishment of the Lowell mills aroused the anger of English manufacturers, and this enmity went so far, it was reported, that emissaries were sent from England to take his life and attempts were made to kill him.

The Pawtucket Canal Company, the stock of which he and Clark were empowered to buy, had been incorporated in 1792 under the name of "The Proprietors of the Locks and Canals on Merrimac River" for the purpose of making the Merrimac River navigable to Newburyport. The construction in 1793 of the Middlesex Canal, however, which opened communication with Boston, was a barrier to the commercial success of the canal to Newburyport, so that the proprietors built only a small canal for the passage of wood and lumber around Pawtucket Falls. As the income to the original proprietors from the canal up to 1820 had hardly averaged $3\frac{1}{2}$ per cent. a year, it was easy for Messrs. Boott, Appleton, Jackson, and the others to purchase the six hundred shares which represented a paid in capital of sixty thousand dollars.

Patrick T. Jackson, Kirk Boott, Warren Dutton, Paul Moody, John W. Boott, and Nathan Appleton made their first visit to the property November, 1821, during a snow-storm. One of the company remarked that they might

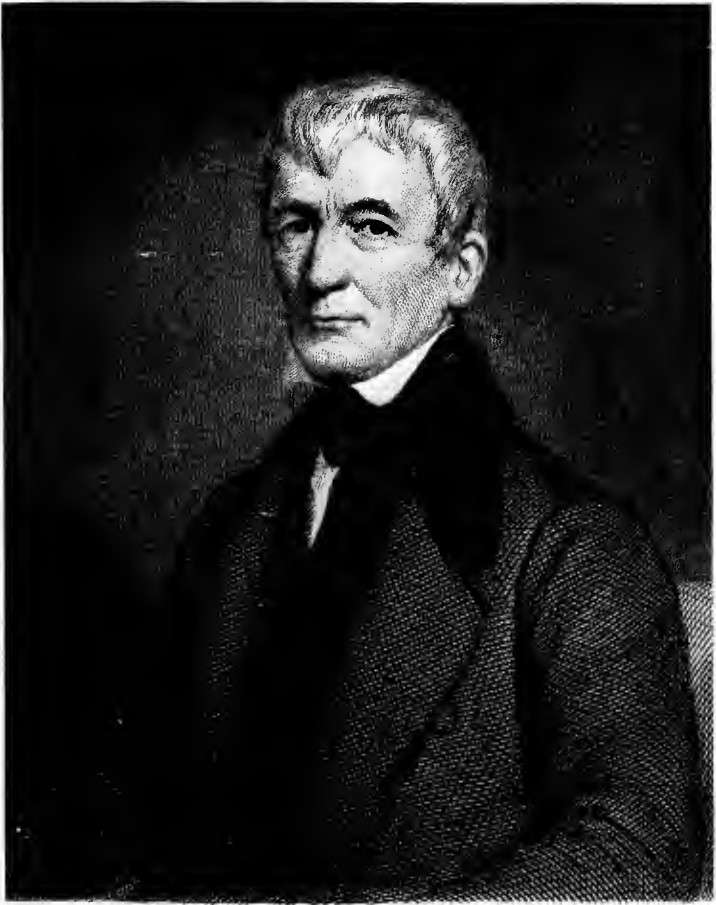

P. J. Jackson

live to see the bleak, barren place which then had less than a dozen houses have a population of twenty thousand people. Articles of association were drawn up under the name of the Merrimac Manufacturing Company, Dec. 1, 1821, with a capital stock of six hundred shares, and Kirk Boott was appointed the treasurer and agent of the company at a salary of three thousand dollars. He was also authorized to buy the remainder of the canal stock, and the Merrimac Company took over from him such interest in the Canal Company as was deemed for their advantage to own.

The Merrimac Manufacturing Company was granted incorporation by the legislature, Feb. 5, 1822, and the following directors were chosen, who ordered an assessment of five hundred dollars per share: Warren Dutton, Patrick T. Jackson, Nathan Appleton, Israel Thorndyke, Jr., John W. Boott; and Kirk Boott was made treasurer and clerk, while Warren Dutton was elected president. The original shareholders were as follows: P. T. Jackson, 180 shares; N. Appleton, 180 shares; John W. Boott, 90 shares; Kirk Boott, 90 shares; Paul Moody, 60 shares. And later it was voted to permit the following to subscribe: Dudley Tyng, 5 shares; Warren Dutton, 10 shares; Timothy Wiggin, 25 shares; William Appleton, 25 shares; Eben Appleton, 15 shares; Thomas M. Clark, 2 shares; D. Webster, 4 shares; Benjamin Gorham, 5 shares; Nathaniel Bowditch, 4 shares; and the Boston Manufacturing Company, 150 shares. D. Webster was Daniel Webster, who is said to have never paid for his shares, and they were subsequently sold to some one else.

The shares in the Locks and Canals Company were paid to the several directors in trust, and a committee appointed, consisting of Patrick T. Jackson and Nathan Appleton, to settle Mr. Boott's account for \$18,399, which he had spent to secure for his associates the farm lands of Nathan Tyler, Josiah Fletcher, and \$30,217, paid for three hundred and thirty-nine shares in the Locks and Canals Com-

pany. The new proprietors of the Locks and Canals Company at once enlarged the canal to sixty feet wide and eight feet deep, at a cost of a hundred and twenty thousand dollars. Collateral canals were subsequently built, and a contract made with the Boston Manufacturing Company for machinery for two mills.

Finally, in August, 1823, the projectors of the Merrimac Manufacturing Company, who now also owned the Locks and Canals, paid the Waltham Company seventy-five thousand dollars for all their patterns and patent rights, and also for the release of the services of Mr. Paul Moody, who had been under contract to work for the Waltham Company. The mills of the Merrimac Company were placed where they could use the whole thirty-foot fall of the Merrimac, and the wheels were first started on Sept. 1, 1823, while the first dividend of a hundred dollars per share was paid in 1825. The first cloth made was so coarse in texture peas could be shot through it, and it cost $37\frac{1}{2}$ cents per yard.

The proprietors of the Locks and Canals erected a large brick machine shop and commenced the building of mill machinery. They soon undertook the complete construction of mills and the installation of machinery, selling land and water privileges to manufacturing companies, digging the necessary canals, erecting the mills, building and installing the machinery, and turning the whole over to the manufacturing company that had been formed. Enormous profits were made on the original cost of the land, and handsome profits were derived, not only from the construction of the plants, but also from the sale of the water privileges. Kirk Boott was the original agent of the Locks and Canals Company, as well as that of the Merrimac Manufacturing Company.

NAMING OF LOWELL

Such was the beginning of Lowell, which took its name from Francis C. Lowell, the originator of the first complete cotton mill in the world. Some difficulty was experienced in determining a suitable name for the new manufacturing town, and one day Mr. Nathan Appleton met Mr. Kirk Boott, who remarked to Mr. Appleton that the legislative committee was ready to report on the bill incorporating the town, and it only remained to fill the blank with the name.

"I consider the question narrowed down to two, Lowell or Derby," said Mr. Boott. Derby was suggested by Mr. Boott because of his family associations with that place, and also because it was in the vicinity of one of the earliest seats of English cotton manufacture.

"Then Lowell, by all means," replied Mr. Appleton, who considered the honor due Mr. Francis C. Lowell.

It was incorporated in 1824 into a town distinct from Chelmsford, of which it had formed a part. Lowell became a city in 1836. Its population in 1830 was 6,477; according to the census of 1910, it was 106,294.

The first cloth made by the Merrimac Manufacturing Company was gray, as the business of printing calico was entirely new in this country. Various methods had been used in experimenting in the printing of calico. The engraving of the cylinder, which had superseded the old method of printing by blocks of wood, had come into use in England, but knowledge of it was closely guarded from the public. Attempts at making copper printing cylinders at Lowell were unsuccessful, and engraved cylinders were imported from England. Finally, Mr. Boott went to England solely for the purpose of securing engravers. Through the efforts of the chemist Dr. Samuel L. Dana and John D. Prince, of Manchester, the task of engraving was finally accomplished, and the first calico printed had a width of twenty-

seven inches, which was two inches above the average of British prints. Only fast colors were used, and this, together with the greater durability secured from the use of the throstle in place of the mule spinning, combined to make the goods better than any others.

The first prints were poor in texture and color. The ground was a madder, and it had a white spot. As described by Mrs. Robinson, who wrote "Loom and Spindle," and, as a girl, worked in these early mills, "it proved a garb of humiliation, for the white spots washed out, cloth and all, leaving me covered with eyelet holes."

The calico printers who were brought over from England became dissatisfied with their terms, and left town, with their families, in a large wagon, with a band of music. New terms had to be made before they would return. The first enduring color printed was indigo blue.

Boarding-houses for operatives were early established by the mill corporations at Lowell, and these houses were strictly supervised. The dietary provided for fresh meat at least twice a week, and that they should not be obliged to eat fresh salmon more than once a week. It was further provided that a bed should be kept empty for a certain number of the occupants, so there would be a place for any one who might be taken ill. A report of illness was sent at once to the mill agent, so that, as it was before the days of hospitals in New England, skilled medical attendance could be provided. The boarding-houses, as well as the mills, were supplied from elevated tanks with running water. The place of these tanks was later taken by a special reservoir, which antedated the introduction of municipal water works. The paved brick sidewalks with granite crossings that were provided from the boarding-houses to the mill doors were probably the first continuous walks of their kind in New England.

The condition of the early employees of Lowell is thus described by Mr. Shirreff, an English farmer, who came

to America to learn if it would be best to allow a younger brother to emigrate:—

“Females engaged in manufacturing amount to nearly 5,000, and as we arrived at Lowell on the afternoon of Saturday we had an opportunity of seeing those connected with some of the largest cotton manufactories returning from labor. All were clean, neat and fashionably attired with reticules hanging from their arms, and calashes on their heads. They commonly walked arm and arm without levity. The general appearance and deportment were such that few British gentlemen in the middle ranks of life need have been ashamed of leading any of them to a tea party. Next day being Sunday, we saw the young females belonging to the factory going to church in their best attire, when the favorable impressions of the preceding evening were not effaced. They lodged generally in boarding houses, and earn eight shillings six pence sterling per week independent of board. Sewing girls earn about four shillings six pence. The recent introduction of large manufacturing establishments and this population account for the comfort and prosperity of the Lowell young women.”

Dickens, in his “American Notes,” describes a visit made to several of the factories at Lowell in 1842, such as a woolen factory, a cotton factory, and a carpet factory, and says that he reached the first factory as the girls were returning from lunch to their work, gave his comments upon their neat, well-dressed appearance, and their extreme cleanliness, and he noted, too, their healthy appearance and admirable manners and deportment. He learned there was as much fresh air and comfort as the nature of the occupation would permit, and declared that in all the crowd he saw in the factories on the day of his visit he could not recall one young face that gave him a painful impression, nor one young girl whom he would have removed from the works, had he had the power.

Dickens found a few children employed in these factories,

but not many, and even at this early date Massachusetts forbade their working more than nine months during the year. He also praised the boarding-houses, and speaks of there being a joint stock piano in many of them. He comments also on the girls subscribing to circulating libraries, and mentions the *Lowell Offering*, a repository of original articles written exclusively by women employed in the mills. In short, Dickens regarded the industrial conditions at Lowell as not only superior to those with which he was familiar in England, but quite above criticism.

Hurd's History of Middlesex County quotes Daniel Knapp as giving this account of the way cotton was cleaned: "In the spring of 1814 my parents were young laboring people, with five small children, the oldest not over eleven years old. We had the cotton brought to our house by the bale to pick to pieces and get out the seeds and dirt. We children had to pick so many pounds per day as a stint. We had a whipping machine made four feet square, and about three feet from the floor was a bedcord running across from knob to knob near together, on which we put a parcel of cotton, and with two whip sticks we tightened it up and got out the dirt and made it ready for the card. My mother was carrying on the bleaching business at the time. There was no chemical process. The bright sun, drying up the water, did its bleaching. This was the mode of bleaching at this time."

STARTING OF FIRST MILLS

The first sale made by the Locks and Canals Company after its reorganization by the promoters of the Merrimac Manufacturing Company was to the Hamilton Manufacturing Company in 1825, which started with a capital of six hundred thousand dollars. The mill made twilled and fancy goods, and the first cotton mill drill which played such a



A MODERN MULE SPINNING-ROOM
(Courtesy of the Podomska Mills)

part in the trade with the East was made in this mill. The Appleton Company and the Lowell Company were started in 1828, and the Suffolk, Tremont, and Lawrence Companies began work in 1830 through the efforts of Amos and Abbott Lawrence, to whom the Locks and Canals Company gave reduced terms because of the stringent business conditions of 1829.

The Boott Company began operations in 1835, and the Massachusetts Company in 1839. Further improvements in the construction of a canal along the bank of the river and the rights to control the outlets of Winnepesaukee were established. Then, too, changes in the water power rights were effected, by which the corporations instead of being lessees of the water power became part proprietors, and from then on Lowell's development was continuous and rapid. In 1911 there were 871,900 spindles, 20,303 looms, and \$12,900,000 capital engaged in the textile business in Lowell.

CHAPTER IX

OTHER TEXTILE CENTRES

PHILADELPHIA THE GREATEST TEXTILE-PRODUCING CITY OF AMERICA—SILK INDUSTRY IN PHILADELPHIA—DEVELOPMENT OF THE WOOLEN INDUSTRY—TEXTILE MACHINERY—CARPET INDUSTRY—LATER GROWTH—FOUNDATION OF LAWRENCE—BEGINNING OF FALL RIVER—COLONEL DURFEE'S MILL—THE TROY AND FALL RIVER MILLS—EARLY LOOMS, WORK, AND WAGES—OTHER COMPANIES—PROVIDENCE—PATERSON, N.J.—NEW BEDFORD—MANCHESTER—AMOSKEAG LAYS OUT A TOWN—NEW YORK—AMSTERDAM—WOONSOCKET, R.I.—CONCLUSION.

The first quarter of the nineteenth century witnessed the firm establishment on a manufacturing basis of the textile industry in America, and the history of this development is that of the great textile centres, where, owing to either natural advantages or the enterprise of far-sighted merchants, the industry was planted and flourished. These centres in the order of the value of their production are Philadelphia, Lawrence, Fall River, New York, Paterson, New Bedford, Lowell, Providence, Manchester, Pawtucket, Woonsocket, and Amsterdam. Much of the story of some of these cities has already been told in previous chapters. To complete it, however, some further facts must be given about the growth of the industry in these cities.

To-day Philadelphia is the greatest manufacturing city of woollen hosiery and knit goods and carpets, New York the greatest centre for the cutting up trade or manufacturing clothier, while Fall River leads as a cotton-producing centre, New Bedford as the greatest producer of fine cotton goods. Lawrence is the greatest centre in the United States for worsted goods, and Paterson the great silk centre. Phil-

Philadelphia's manufacture of textiles exceeds \$153,000,000 annually, while that of the next two largest textile cities, Lawrence and Fall River, aggregates only \$126,000,000. Considering Lawrence, Fall River, Lowell, and New Bedford as cities of Boston's environment, the output of "Greater Boston" is \$211,000,000.

According to the United States Census the textiles include carpets, cordage, jute, linen goods, nets and seines, cotton goods, including cotton small wares, dyeing and finishing, hosiery and knit goods, shoddy, silk manufactures, woolen and worsted manufactures, wool pulling, wool scouring, felt goods, wool hats and fur felt hats.

The production of the twelve leading textile cities of the United States, according to the 1909 census, was: Philadelphia, Pa., \$153,000,000; Lawrence, Mass., \$70,000,000; Fall River, Mass., \$56,000,000; New York, N.Y., \$52,000,000; Paterson, N.J., \$50,000,000; New Bedford, Mass., \$44,000,000; Lowell, Mass., \$41,000,000; Providence, R.I., \$37,000,000; Manchester, N.H., \$23,000,000; Pawtucket, R.I., \$23,000,000; Woonsocket, R.I., \$20,000,000; Amsterdam, N.Y., \$17,000,000.

The total value of the output of the textile industries of the United States in 1909 was \$1,684,636,500, or \$200,000,000 more than all of Great Britain and Ireland. Philadelphia produced nearly one-tenth of all the textiles of the United States, or more than any other two cities combined, and the value of the textile product exceeds that of any other city of the world.

The earliest efforts at textile making in Philadelphia began soon after 1682, when the city's manufactures of coarse woolens excited the jealousy of England and led to prohibitive legislation. The proficiency was no doubt due to the premiums for the production of cloth offered by the proprietors of the province, one of the first being awarded Abraham Opdengraefe in 1686 for a piece of linen, and soon after Wigert Levering, a Germantown settler, is mentioned

as a weaver by trade. The first manufacturers of hosiery were those of the sect known as Mennonites, who about this time had set up in their homes in Germantown the stocking frames they brought from Germany, and thus started the industry for which Germantown was to become famous.

Wool was being made into druggets, serges, and camlets in 1698, and among the trades mentioned are dyers, fullers, comb makers, card makers, weavers, and spinners. Wool combers and carders received twelvecence per pound, and journeyman tailors twelve shillings per week and their diet. Charles Blackman, who enjoyed the governor's favor, was the first tailor mentioned. An evidence that the industry was already well established is the fact that Charles Lawrence, who had come from Carolina, offered for sale in 1721, at his place of business on Chestnut Street, "Very good sleys, tombles, and shuttles for weavers." John Cam, who had emigrated from Ireland, was spoken of in 1723 as a stocking weaver, as was also Alexander Mack, Jr., son of the founder of the religious sect known as "Dunkers," and Germantown had thus early become the headquarters in America of the hand stocking weavers, one hundred Germantown hosiers being referred to in 1777 as out of work.

The first knitting mill in America was started in 1825 by Thomas R. Fisher in Germantown, and it was known as the Wakefield Mill. Previous to this each man had worked his own frame in his own house, but Fisher persuaded a number of knitters to operate their machines under one roof. He offered to buy the frames; but, as the knitters refused to sell, he imported frames from England, and knitters too, and was soon able to operate his own frames with his own workmen. Already numbers of knitters from Leicester and Nottingham had settled in Germantown, and little by little the knitting industry grew until it took the leading position it now holds.

SILK INDUSTRY IN PHILADELPHIA

Influenced by the strenuous efforts made by the mother country to establish the silk industry in her colonies, Philadelphia turned her attention to the silk industry about 1750, and offered premiums for the growth of the silkworm as well as opened a filature. A London paper under date of Nov. 7, 1765, states that one hundred silk throwsters had started for New York and Philadelphia. Benjamin Franklin in 1769 influenced his adopted city to open another filature, and in 1771 twenty-three hundred pounds of cocoons were bought and reeled by a society formed to promote the industry.

Dresses of domestic silk were made and worn before the Revolution, some of which have been handed down as heirlooms to the present. But the Revolution terminated the industry, and it was not resumed until 1815, when W. H. Horstmann came from Cassel, Germany, and, having learned the art of silk weaving in France, established himself in Philadelphia as a silk manufacturer. He was the first to use the Jacquard loom in America, introducing it in 1824, and also inventing a number of machines used in different branches of the silk manufacture. His son, William J. Horstmann, in 1837-38 made power looms from his own design and introduced power loom weaving for narrow fabrics. Silk manufacturing in Philadelphia has since grown until in 1910 there were seventy-seven firms making silk goods of various kinds in Philadelphia.

DEVELOPMENT OF THE WOOLEN INDUSTRY

The woolen and flax homespun industry started in Philadelphia, as it did in the other colonial cities, immediately after the town's settlement, and little by little grew as the needs of the people required fabrics.

In 1760 there were twelve fulling mills in Philadelphia,

and in 1765 a number of citizens and butchers agreed not to eat or kill sheep under twelve months old for a period of two years. About the time the Stamp Act was repealed in 1766, Daniel Mause, a hosier, had set up a number of looms at the sign of the "Hand in Hand" Stocking Manufactory on the west side of Second Street, between Race and Vine Streets, where he made thread and stockings, and "hoped the good people of his and neighboring provinces would encourage the undertaking."

But so little had manufacturing grown in Philadelphia by 1767 that John Penn, in a letter to the Lord Commissioner for Trade and Plantation, on January 21 of that year said that very little encouragement was given manufacturing, and he only knew of two industries. One had been started three years ago by private subscription for making sail cloth, ticking, and linens, but the persons interested had not carried it on, but sank their money and discontinued the project, as the high price of labor made it impossible to compete with English goods. The other was a glass manufactory, which was started seventy miles from Philadelphia, in Lancaster County, to supply the demands of the villagers and small farmers in the neighborhood.

The approach of the Revolution, the growing needs of the colonists, and the time and expense it took to obtain goods from England led Philadelphia, as well as other colonial centres, to consider the question of home manufactures, and, when the convention of delegates from the Pennsylvania provinces was held in 1775, various newspaper writers recommended the establishment of woolen manufactures. One writer, who signed himself "Hibernian," proposed the formation of a patriotic society to manufacture woolen with a permit to raise one thousand pounds by lottery. Weavers, he wrote, could be had from Ireland. The expense of importing twenty-nine workmen with yarn and worsted, wheels, reels, looms, steel, three-pitched combs, a press, and bedding for the twenty-nine hands, was

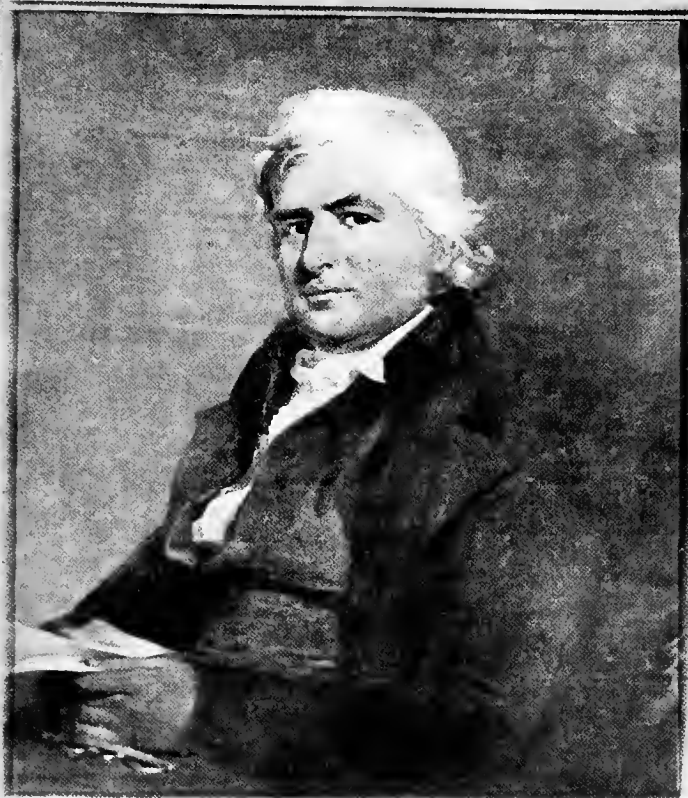

Samuel Waterhill.
Born, April 27th 1764. Died, September 29th 1829.

estimated at five hundred and fifty pounds. Six thousand pounds of yarn could be bought for four hundred and fifty pounds, but the profits of manufacture were not calculated.

The first joint stock company in the United States was organized in 1775 in Philadelphia to make cotton goods, and was known as the United Company of Philadelphia for Promoting American Manufacturing. It was the progenitor of the American Manufactory, the earliest cotton and woolen manufactory in America. Samuel Wetherill, Jr., who was instrumental in the formation of the manufactory, had in 1775, on South Alley, a factory for woollens that supplied the Revolutionary army, and, when the price of wool rose so high that he could not avoid loss, he notified the Board of War that he would be unable to fill his contract.

The colonial government of Pennsylvania encouraged home industries by offering medals and money for the best cloth; and John Hague in 1778 received one hundred pounds for introducing machines for carding cotton. The same year John Hewson, the first calico printer, sought financial support from the Assembly, as did also Edward Clegg, of Great Britain, who was about to establish a mill for corduroys and jeans. By 1784 fulling mills were very numerous in Philadelphia, and by 1810 three woolen mills had been established in Philadelphia, and one in Germantown.

TEXTILE MACHINERY

Philadelphia has long been a centre for textile machinery. As early as 1777 Oliver Evans made teeth for cards by a machine of his own invention, which turned them out at the rate of fifteen hundred per minute. When the State rejected his proposal to erect a factory under State patronage, he disclosed his secret to individuals, and soon many were making cards. In 1788 Giles Richards & Co. began making them with machines. F. G. Richards, Amos

Whittemore, and Mark Richards turned out about twelve thousand annually.

From 1792 to 1794 a number of carding machines were made, and efforts exerted to build spinning frames on Arkwright's principle. At the Globe Mills, to which we have already referred, several mules of one hundred and twenty spindles were installed.

The first regular machinery for cotton manufacturing was established at Holmesburg in 1810 by Alfred Jenks, who had learned all he knew from Slater. In 1830 Jenks invented the power loom for weaving checks.

Little by little the industry became well established, and different societies were formed to stimulate it. The Philadelphia Premium Society, organized in 1801, did much to foster the industry by giving premiums for improvements in art and manufacture, and no longer did Penn's statement about the lack of manufacturing apply to Philadelphia.

Fairs and sales were held, one of the first sales being in 1789, under the auspices of the manufacturing committee of the Pennsylvania Society, when printed cottons, corduroys, federal ribs, jean, flax, and tow linens were offered. According to John Mellish, who wrote a description of his travels in America in 1806-07 and 1809-11, the manufactures of Philadelphia were rising into great importance, hats, stockings, and a great variety of cloth were being made, and an export trade had begun.

CARPET INDUSTRY

The carpet industry, for which Philadelphia has long been noted, began before the Revolution and gradually became a prominent industry. The first manufacturer mentioned was William Calverly, of Loxley's Court, whose carpets in 1774 were thought to be superior to those imported, and were shown as such at the Coffee House. Turkish and Axminster carpets were first made by William

Peter Sprague in 1791 in Northern Liberty. He wove a national pattern with device representing the crest and armorial achievements of the United States. Philadelphia floor cloths, oil cloths, and carpets began to attract wide attention soon after 1800. John Dorsey, a merchant, with two looms commenced making floor carpets and oil cloths in 1807 on Chestnut Street, and he wove a sail duck seven yards in width. One man could turn out thirty-two or forty-five yards of carpet a day, which sold for from \$1.50 to \$2.25 per yard, depending upon the colors used. Another factory was established by Isaac Macauley at Market Street in 1808, where he made oil cloths in one, two, three, and four colors. He bought out Dorsey in 1810, and began manufacturing on a wider scale. Setting up carpet looms and importing workmen from Kidderminster, England, he spun his own yarn and wove canvas twenty-one feet wide for oil cloth, as well as the first Brussels carpet in America.

In 1811 Philadelphia had 273 looms, 3,648 spinning wheels, 186 looms and fly shuttles, 4,423 spindles in factories, 165 stocking looms in hosiery factories, 8 print works, 4 print cutting establishments. The population of the city was in 1810 111,210, and the total value of all manufactures was \$16,103,389.

LATER GROWTH

The close of the war with Great Britain in 1815 brought such an influx of English goods that the domestic industries were threatened with extinction, and Thomas Gilpin and other Philadelphia manufacturers protested to the government against the ad valorem rate of duty, which led to false valuation, and asked for specific duties in hope of saving the home industry; but the introduction of the power loom did more than the tariff to save the struggling industry, and little by little it became prosperous again. There were in Philadelphia in 1815, 2,325 persons engaged in the

cotton industry, and 1,226 in the woolen. By 1821 four thousand looms were at work. In 1827 the Frankford Woolen Mills were established, and in 1829 the Conestoga Print Works, by Thomas Hunter. Andrew and William McCallum, two Scotchmen, started their carpet manufactory in 1830, and in 1831 the Germantown Hosiery Mills were started under the direction of John Button, whose father was a lace maker of Leicestershire, England. Button had at first but two small machines for knitting hosiery, which he had brought from England, and first made children's hose. As he was the only one who had this machinery, for several years he had quite a monopoly, but later made adult hose as well. Germantown knit goods rapidly became famous, and mill after mill sprang up.

The Oxford Carpet Mills were started in 1832 by William Hogg, and also the Hinckley Knitting Mills by Aaron Jones, who set up two old-fashioned knitting frames. The city and neighborhood in 1827 had 104 warping mills, 4,500 weavers, over 200 dyers, 3,000 spoolers, and 2,000 bobbin winders. The blue broadcloth known as Lafayette Blue, dyed in 1832 by F. Tassard with prussiate of potash, was the first use in America of Prussian blue.

The Keystone Knitting Mills were started in May, 1861, by Thomas Dolan, who had been a commission merchant, and since then the development of Philadelphia has steadily grown. According to the last census the gross value of Philadelphia's textile products was \$153,000,000.

FOUNDATION OF LAWRENCE

The history of the foundation and development of Lawrence bears close analogy to that of Lowell, save that one man instead of several conceived the enterprise and carried on the preliminary work necessary to its successful start.

That man was Daniel Saunders, of Andover, Mass., who had become interested in the project by the merest accident.

He came by chance some time before 1835 into possession of a plan showing the grades and locks for a canal from Lowell to the tide-water on the Merrimac, and, studying it closely, concluded there was considerable aggregate fall of water between the two points, though apparently there was little individual fall in the few slight rapids.

As Saunders had been engaged in the woolen business, he realized the value of the water power for mill work, and determined to investigate for himself. Accordingly, with a companion and equipped with only a straight edge and a spirit level he went over the falls between the two points, and discovered the great power hidden in the insignificant rapids. He kept the information from all but his immediate family, to whom he freely predicted the possibility of a great manufacturing city on the Merrimac in the towns of Methuen and Andover, and set about buying land sufficient to control the water power. In 1840 he began purchasing land at the head of Peters Falls, some distance above where the first mills were built, and also bought an island and some land lower down. Soon he had sufficient to control Peters Falls, and thus the whole power of the river. He had enough land by 1843 to deem it safe to lay his plan before J. G. Abbott, John Nesmith, and Samuel Lawrence, all residents of Lowell, and they formed the Merrimac Water Power Association, with Daniel Saunders, Jr., Abbott Lawrence, Thomas Hopkinson, and Jonathan Tyler, of Lowell, and Nathaniel Stevens, of Andover, as the other stockholders.

The company set about securing more land to protect their rights. Some adverse criticism of the scheme arose, and many of those sceptical of the success of the enterprise called the scheme "Saunders' Folly." It was proposed to call the new town Saunders, but Mr. Saunders objected, suggesting that, as it was on the Merrimac and there was no town in Massachusetts by that name, it be called Merrimac, and so it was called until April 17, 1847, when it

was incorporated as a town and took the name of Lawrence in honor of Abbott Lawrence, one of the subscribers to the enterprise.

Saunders in eighteen months had bought up all the land needed save a few parcels, and controlled in all between three and four thousand acres. On March 20, 1845, Daniel Saunders, Samuel Lawrence, John Nesmith, and Edmund Bartlett received a charter as the Essex Company.

In the privately printed Memoir of Abbott Lawrence, by H. A. Hill, it is said that on the day that the Massachusetts legislature passed the bill incorporating the Essex Company, successor to the Merrimac Water Power Association, all of the incorporators, among them Mr. Abbott Lawrence, were at the State House, and as soon as the measure was signed started to North Andover by rail, and thence proceeded to the falls at Lawrence by carriages.

The company consisted of Messrs. Abbott Lawrence, William Lawrence, Samuel Lawrence, Francis C. Lowell, John A. Lowell, George W. Lyman, Theodore Lyman, Nathan Appleton, Patrick T. Jackson, William Sturgis, John Nesmith, Jonathan Tyler, James B. Francis, and Charles S. Storrow, the engineer of the enterprise.

Under the direction of Mr. Daniel Saunders a careful examination of the neighborhood was made and the various plans for harnessing the water power were discussed upon the spot. Subsequently the party sat down to dinner at the Merrimac House in Lowell. After dinner, steps were taken toward a permanent organization.

Mr. Abbott Lawrence and Mr. John A. Lowell retired for a few minutes' consultation, and when they returned offered the Water Power Association for all of its rights and interest thirty thousand dollars over and above the reimbursement of all expenses previously incurred. It was also agreed to carry out all of the agreements of the Associates for the purchase of land to secure flowage rights and to head the

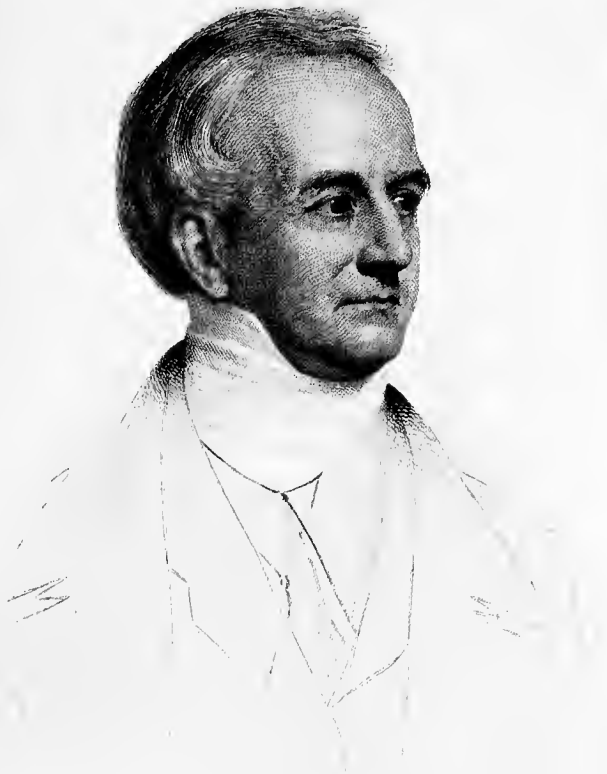

Abbott Lawrence

organization of the Essex Company by a large subscription of stock.

The proposition was accepted, and the preliminaries were signed the same day, March 20, 1845. Mr. Lawrence was the first and largest subscriber to the Essex Company, taking a thousand shares at a hundred dollars each, and was its first president. On April 16 stock to the amount of a million dollars was issued, with Abbott Lawrence, Nathan Appleton, Ignatius Sargent, and William Sturgis as directors. Charles Storrow was made agent and chief engineer.

A great dam was completed across the Merrimac Sept. 19, 1848, canals were dug, and the town site was laid out, work being begun Aug. 1, 1845.

The Washington Mill, built in 1846, was the first one completed, and E. A. Bourne was chosen president. It started the next year, when it took the name Bay State Mills, woolen, worsted, and cotton goods being made. The Bay State shawls, first made in 1848, and the blue flannel coatings, first turned out in 1859, were widely known. A few months later the second mill, the Atlantic, was started, and the first cotton arrived Jan. 12, 1849, consigned to the Atlantic Cotton Mills, of which Mr. Lawrence was also president and one of the largest stockholders.

The Pacific Mills, named from the Pacific Ocean, were incorporated in 1853, and at that time were the largest works of their kind in the world. Their original capital was \$2,000,000. Mr. Abbott Lawrence was president. The mills in 1857 had to ask an extension of credit, and Mr. Lawrence contributed several hundred thousand of his personal fortune to save the enterprise, upon which one-third of the people of Lawrence were dependent. Since the struggles of these early days the Pacific Mills have been very successful, and their products are known over the world. Other mills have since sprung up, one of which, the Wood Worsted, which is owned by the American Woolen Company, is the largest worsted mill in the world. The

population of Lawrence, which in 1845 was a few hundred, was 85,892 in 1910, and had 1,138,876 spindles in 1911. The Census Bureau reports that the value of its textile products is \$70,000,000 annually.

BEGINNING OF FALL RIVER

The greatest cotton manufacturing centre of America is Fall River, Mass. In one hundred years the cotton industry has transformed a high, rocky knoll on the shores of Mount Hope Bay, which was once the scene of many an Indian skirmish between King Philip's tribe and the Pequot and Narragansett Indians, from a town in 1800 of 2,535 people into a city in 1910 of 119,205 which hums with the whir of 3,936,944 spindles and with the clatter of 93,904 looms. Colonel Durfee's original mill when it started in 1811 contained not more than five hundred spindles.

The great development of Fall River is due to the fact that the moist climate of the neighborhood makes it one of the few places in America where the textile industry has that degree of humidity so needed in the weaving of cotton goods, and also to the fact that the headlong plunges which the stream of water known as the Quequechan River, or "The Stream," takes here over its rocky bed on its way to mingle with the ocean, furnished the water power so essential to the early mills.

COLONEL DURFEE'S MILL

The influence of Samuel Slater, who had been so successful in introducing to America English methods of manufacturing cotton, led Colonel Joseph Durfee, a Revolutionary patriot who lived in Tiverton Village, to organize and construct in 1811, in what was then the village of Fall River, the Globe Mill, the first mill built there. Colonel Durfee had been a selectman of his town and had served in the

Revolution. When the British, who during the Revolution held Newport, attempted to raid the territory of Globe Village, Durfee formed and led the home guard which repulsed them. At the time he organized the company he was sixty-one years old, and owned much of the land where Fall River now is, and thus controlled the water power.

The ownership of Durfee's mill was divided into 100 shares, which he sold to his neighbors and friends as follows: Joseph Durfee, of Tiverton, 40; Seth Simons (carpenter), of Providence, 40; Nathan Chase, Tiverton, 5; Boulston Brayton, Tiverton, 3; William Durfee, Tiverton, 2; Benjamin Brayton, Gray, 2; Elisha Fuller, Rehoboth, 1; Robert Hazard, Rehoboth, 1; and Nathan Cole, Rehoboth, 6. His argument in inducing his friends to buy the stock was that "cotton cloth would darn much easier than linen and ought to be popular in the home."

The original mill, a small one-story wooden building that stood on the north-east corner of Globe and South Main Streets, was burned, and later the old building now standing was erected. It is one hundred and twenty feet in length, thirty-two feet wide, with a projection on the west side about thirty-one feet by eight, and three stories in height. The original mill had a water wheel that was operated by the flow from the Globe ford which had been dammed, and contained only a few spinning frames, cards, and a calender, and had, as we have said, but five hundred spindles.

The cotton was sent out to the farmers' families to be picked and cleaned, and then was spun by the mill. The spun roll was then again sent out to be woven, and the cloth was finished by the mill. It is not known how much of the machinery was driven by power, although the mill had a tub wheel which gave such uneven power, according to the flow of the water, that the threads were not only constantly breaking, but the machines often went so fast they fell apart. The workmen were inexperienced, the hours of work averaging about sixteen, the pay about \$1.20 per day, and

the output was very crude. The finished goods were carted two miles to Fall River proper, whence they were shipped by schooner to Providence and the neighboring territory, where they were sold.

In spite of Durfee's persistency in constantly trying new devices to improve the crude machinery which was continually breaking, he was unable to make a success of the undertaking, and, although the mill was run by the residents of the little village until 1829, it was never a financial success, and Durfee died a poor man in 1843.

From 1829 to 1839 the plant was operated as print works, being known from 1835 to 1839 as the Tiverton Print Works. After many vicissitudes the mill came into the hands of the present owner, The Globe Yarn and Laurel Lake Mills Company, and is held by them because of the water power it controls. Many interesting mementos of the old mill are still in existence, such as time sheets that contain the names and pay of the old workmen. Among the names of the workers are those of the ancestors of some of the leading professional and business men of Fall River to-day.

THE TROY AND FALL RIVER MILLS

If Colonel Durfee's venture was not a success, he at least pointed to the direction of Fall River's real prosperity and led the way, for in 1813 other residents of Fall River followed the path which he had blazed. In this year two corporations for the manufacturing of cotton and woolen cloth were formed, known respectively as the Troy Manufactory Company, later called the Troy Cotton and Woolen Manufactory, and the Fall River Manufactory. The incorporators of the Troy corporation—so called because at that time Fall River was a village in the town of Troy—were A. Borden, Clark Chase, Oliver Chace, James Maxwell, Jonathan Brown, William Slade, N. M. Wheaton, Oliver Earl, Eber Slade, Joseph C. Luther, Sheffel Weaver, John Stock-

ford for Charles Wheaton and self, Nathaniel Wheeler, James Driscoll, Benjamin Slade, Daniel Buffington, Hezekiah Wilson, Benjamin Durfee, William Read, Robinson Buffington, John Martin, and Benjamin Buffington. The capitalization was fifty thousand dollars. The Fall River Manufactory with a capital of forty thousand dollars was incorporated by David Anthony, Dexter Wheeler, and Abraham Bowen. The Fall River Manufactory was organized Feb. 11, 1813, and the Troy Cotton and Woolen Manufactory March 8, 1813. The mill of the Fall River Manufactory was completed in October, 1813, and was about sixty feet by forty feet, three stories, the lower being of stone and the upper two of wood, as it was said "there was not enough stone in Rhode Island to finish it with." It started some time before the Troy mill, the erection of which was completed in September, 1813, though work at the Troy mill did not commence until the middle of March, 1814. The Troy mill was built of stone from the neighboring fields, was four stories in height, had a low hip roof, and was one hundred and eight feet long and thirty-seven feet wide. As compared with the mammoth mills of to-day, these mills were infants, but they were the forerunners of all that followed.

Strange to say, all of the original mills, Durfee's, the Troy and the Fall River mills, were burned, and the present structures were built on the old sites. Mill after mill sprang up, the cotton being brought to Fall River in small sailing vessels, having been hauled to the Southern coast by mules or horses or brought down the streams. Little cotton was then cultivated in the South at a distance remote from the coast, and a great deal was brought to New York and reshipped to New England. So bad was the condition in which it was received from the South that it had to be sent out by the mills to women in the neighborhood, who picked out by hand the seed that still clung to the cotton.

EARLY LOOMS, WORK, AND WAGES

In the beginning these mills spun only the cotton for the weaving, the yarn being put out to be woven on hand looms by women in the neighborhood. The first power weaving was done in the Fall River Manufactory in 1817, on a heavy, clumsy loom, invented by Dexter Wheeler, that frequently got out of order, while the dressing was so poor that often the yarn would mildew and rot on the beam.

The first loom is said to have been started by Sarah Winters, the second by Mary Healy, and the third by Hannah Borden. The cloth was woven a yard wide by weavers who received \$2.50 per week, and was sold for twenty-five cents in the stores that were often a part of the mills. In 1819 fifteen hands ran thirty looms in the Fall River mill. Three were employed in the dressing-room, ten in the carding-room. In all the mill had not more than thirty-five employees. The work began at 5 A.M. in summer, and as soon as it was light at other times. At eight o'clock there was a half-hour for breakfast, and at noon another half-hour for dinner. In some of the Fall River mills the male help at eleven o'clock were treated to New England rum. At 7.30 P.M. the work stopped and the mills shut down. On Saturdays the mills closed at four or five o'clock in order to allow the employees to prepare for Sunday. The workers were then all Americans. A mill superintendent drew \$2 per day; overseers, \$1.25 per day; male workers, from \$0.83 to \$1 per day; while women received still less, and boys or girls from \$1 to \$2 per week.

Power looms were not installed in the Troy mill until the latter part of 1820. The spinning frames had seventy-two spindles each, and the best spinners ran only a pair of frames, which produced two and one-half skeins per spindle a day. Blair's picking machine was first used by the Fall River Manufactory. Previously the mills had been paying four cents a pound for hand picking, and five or six pounds

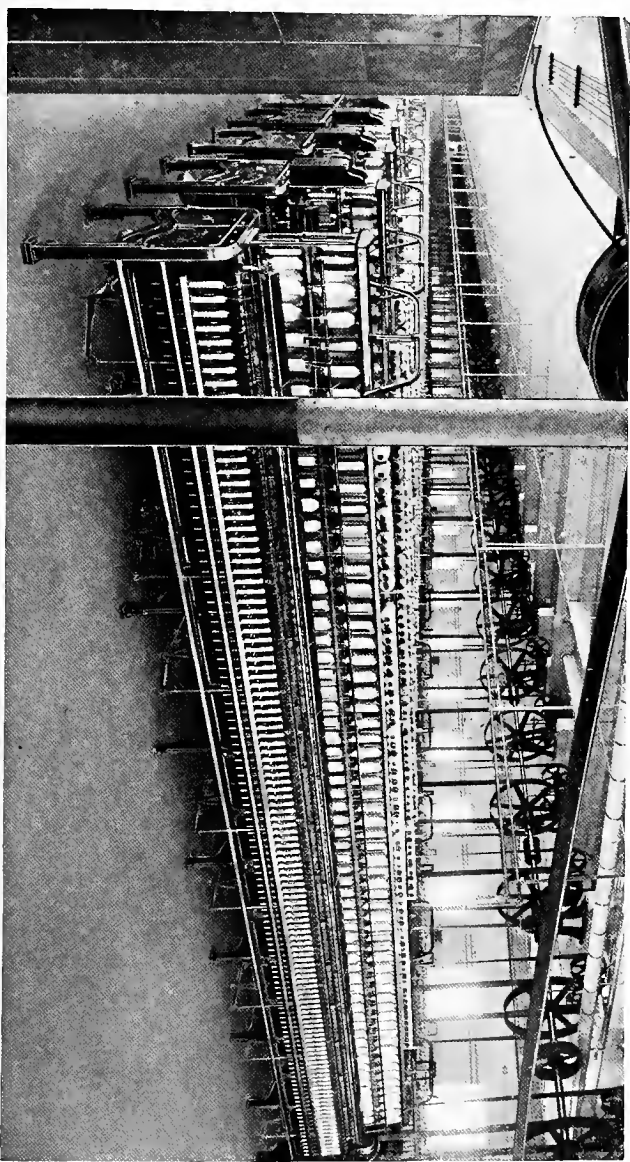

INTERIOR VIEW OF A MODERN RING SPINNING MILL.
(Courtesy of the Harmony Mills)

were considered a good day's work. The first dresser used in the Fall River mill warped the beam in sections of about an eighth of a yard at a time; while the roping until 1825 was made in cones with open tops or with tops that had to be wound by hand upon the bobbin, and very little of the yarn was over No. 16.

Here at first, as elsewhere in New England, linen was used for the warp and cotton for the filling, or weft, but the introduction of imported machinery soon produced cotton of sufficient strength to serve as the warp as well as the weft.

As there were no middlemen in these early days, the manufacturers were obliged to find their own market, and cloths were accordingly sold directly from the mill to the people of the surrounding country. The products were very coarse sheetings, and then plain cloths, and, when color was wanted, the yarn was dyed. Company stores were generally maintained by these earlier mills, so that the employees seldom received their wages in cash, but were generally paid in provisions and other supplies from the general store, over the counters of which the mills also sold their products.

OTHER COMPANIES

The Union Cotton Factory was started in 1813 in a small wooden building, on the site of the Laurel Lake Mills, in what was then Tiverton, by Edward Estes and others, and was the third mill in Fall River. It was burned in 1838.

The fourth company to be incorporated in Fall River was the Pocasset Manufacturing Company, which was organized in 1822 with a capital of one hundred thousand dollars, the principal owner being Samuel Rodman, of New Bedford, who became its president, while Oliver Chace, of the Troy mill, was engaged as agent. The mill, which was built of stone and was one hundred feet by forty feet and

three stories high with a long L at the south end extending over the river, proved too large for the company's business, and in 1824 Andrew Robeson, of New Bedford, hired a part, and started the first plant for printing calico in Fall River.

The printing was first done in the north end of the old Satinet Mill, which took its name from the class of woolen goods made there, and the first printing machine that Robeson used was made by Ezra Marble and a French immigrant who had obtained in France the necessary knowledge, and was set up about 1827, though it was some years later that machine printing superseded the hand and block process.

It was soon found that Robeson's shop could not fill the requirements of the growing industry, and in 1834 Holder Borden organized the American Print Works, the predecessor of the American Printing Company. With him were associated many of the stockholders of the Fall River Iron Works, another early industry of Fall River. The American Print Works started in January, 1835, with four machines, and handled from two thousand to twenty-five hundred pieces a week, and the company has since grown to be the largest print works in America.

Steam was first used in Fall River in "the Doctor's Mill," so called because it was later owned and run by Dr. Nathan Durfee. The mill was built in 1845 at the foot of Cherry Street. It was also called the Massasoit Steam Mill.

Fall River was the first American textile centre to use Sharp & Roberts self-acting mules. They were brought to America in 1838 by William C. Davol, who had succeeded in purchasing some of the mules in Manchester, under an agreement with the Sharp people that he would manufacture them for the Sharps under an American patent. It was one thing, however, to buy the machines but quite another to take them out of England, owing to the jealous restrictions that she placed about the exportation of textile machinery. To circumvent the law prohibiting the

machinery from leaving England, Mr. Davol arranged with agents in England to take the machinery down, saw it into small pieces, pack it in narrow boxes as if it were plate glass, and ship it to America by way of France, where it arrived safely two years after its purchase. It was easy for Mr. Davol's firm of machinists,—Haines, Marvel & Davol,—with their expert knowledge of mechanics and his familiarity with the machines, to put the machinery together again and duplicate its construction in other machines. It was not until 1846 that they installed the mules in the Metacomet Mill, which he and Major Bradford Durfee constructed in that year from plans they brought from England.

In 1832 the American Linen Company was organized to make the better grade of linen fabrics, the first of their kind in America, workmen as well as the flax being brought from England. At first the mill was very successful, but, as cotton fabrics took the place of linen, the business fell off, until finally in 1838 linen making was abandoned and the factory has since been operated as a cotton mill.

The development of Fall River has since been rapid, although its progress has been affected by the different financial depressions which have periodically hampered the American industry. Mill after mill has been established in Fall River until to-day the city is one of the leading textile centres of America, its annual product, according to the last census, being \$56,000,000.

PROVIDENCE

The beginning of the industry in Providence has already been briefly referred to in a preceding chapter. Fulling mills were in operation at an early date. One of the earliest references to the industry is in January, 1704, when William Smith, a weaver, received a piece of land forty feet square "to build a weaver's shop upon, he being desirous to follow

his weaver's trade"; and in December, 1700, Joseph Smith, a brother, was granted for the same purpose three acres of land near Wanskuck. In 1674 Moses Lippitt was indentured, by Edward Sairle and Anna Sairle, his step-father and mother, for fifteen years and a half and two months to William Austin to learn the trade of weaver.

The eighteen young ladies of Providence belonging to the "Daughters of Liberty," of whom we have already spoken, met by invitation at the house of Ezekiel Bowen in 1766, and spun linen from sunrise to sunset to encourage home industries. The organization increased rapidly, and held meetings at the Old State House on North Main Street, where they wove a handsome web of linen to be given as a prize to the farmer who might raise the most flax that year. The General Assembly for a time offered a bounty of one-third of the value of the finished product.

Soon after the peace of 1783 Rhode Island began turning its attention to manufactures, and in 1787 the first company in the State for the manufacture of cotton was formed at Providence. Its object was to make homespun cloth by hand. The first enterprise was begun, as we have related, under the auspices of Daniel Anthony, Andrew Dexter, and Lewis Peck. They built a jenny of twenty-eight spindles after the Orr models at Bridgewater, and set it up in a private house at Providence, and subsequently moved it to the market house and operated it there; after that a spinning frame having eight heads of four spindles each. The spinning frame constructed was afterwards taken to North Providence to be worked by water, but it was found to be too imperfect for use.

While the experiments were being made in the chamber of the market house, two weavers, Joseph Alexander and James McKerries, came from Scotland to Providence, claiming to understand the use of the fly shuttle. McKerries settled in east Greenwich, while Alexander took up his residence in Providence. A loom was built by Alexander

for making corduroys and set up in the market house. It was operated, as we have already seen, with more or less success, but no one knew how to cut the corduroy and give it the proper finish, so the manufacture was soon abandoned, when Alexander removed to Philadelphia.

A notice printed in the *Gazette and Country Journal*, Aug. 8, 1789, read, "Almost every family seems more or less engaged in this way" (promoting manufactures in this town).

"There are now also at work a carding machine with a three-foot cylinder, two spinning jennies of sixty spindles each, and one of thirty-eight spindles, and a mill after Arkwright's construction, which carries thirty-two spindles by water, from which machines, as well as large quantities spun by hand, Corduroys, Jeans, Fustians, Denims, &c., &c., are making. There are several other machines for the Wool Manufactory, among which the Wool Picker and Flying Shuttle are improvements every raiser of Sheep and Manufacturing Family should possess."

The arrival in 1790 of Samuel Slater greatly stimulated the industry in Providence, as elsewhere in Rhode Island, and the first cotton thread spun by machinery in Rhode Island was spun in the chamber of the market house in Providence. The first cotton thread spun by water in the United States was spun in North Providence.

John Fullem worked a stocking loom in Providence about 1788, and in March, 1790, a calendering machine worked by horse-power was set up there.

In 1790 Henry Vandausen, a German, began calico printing at East Greenwich, cut his own blocks, and printed for people generally cottons and the coarse cotton wove in families. But the first print works in the country did not prove profitable because of English and Indian goods.

In 1794 Messrs. Schaub, Tissot & Dubosque engaged in printing calicoes in a chocolate mill later occupied by the Franklin Machine Company. Dubosque, who had been in the French navy, learned calico printing in Alsace before

entering the navy. Calcutta cottons were used, and the printing was done with wooden blocks, while the calendering was done by friction with flint stone.

In 1797 Peter Schaub and Robert Newell began the same business, cotton cloths imported from the East Indies being used and wooden blocks employed to give the figures and colors. Previously calico printing had been carried on at East Greenwich. This is supposed to have been the first calico printing done in America.

In 1790, 30,000 yards of woolen cloth were made in and around Providence; and, in 1791, 25,265 yards of linen, 5,895 of cotton, 3,165 of woolen, 512 of carpeting, 4,093 pairs of stockings, 859 pairs of gloves, and 263 yards of fringe. In 1794 cotton twist was made at Providence, in Nos. 12, 16, 20, which were respectively sold at \$0.88, \$1.04, and \$1.21.

There were thirty-eight cotton mills in Rhode Island in 1812 with 30,669 spindles. The first duty on cotton goods was 10 per cent. In 1797 it was raised to 12½ per cent. At the close of the War of 1812 a gigantic petition was sent to Congress for protection, and in 1815 one cent a spindle was raised to pay the expenses of Agent James Burrill to represent Massachusetts and Rhode Island before Congress. In 1816 the duty was fixed at 25 per cent. ad valorem upon cotton and woolen.

At the close of the War of 1812, there were 99 cotton mills with 75,678 spindles in or near Providence, R.I.; Massachusetts had 57 mills with 45,650 spindles; Connecticut, 14 mills with 12,886 spindles; or 170 cotton mills in all with 134,214 spindles.

Owing to Slater's influence and the abundant water power about Providence, the industry developed rapidly, and to-day the territory within thirty miles of Providence is the greatest textile centre in America. According to the latest census the output amounted to \$37,000,000.



T. G. H. A. M.

Ann Lane

PATERSON, N.J.

The enterprise of Slater at Pawtucket had also much effect in influencing some gentlemen of New York, New Jersey, and Pennsylvania to start a movement for the establishment of a cotton industry in or around New York. The result was an elaborate plan for the establishment of the textile industry on the Great Falls of the Passaic River and the consequent foundation of Paterson as one of the textile centres.

The prime mover in the enterprise was Alexander Hamilton, Secretary of the Treasury, whose interest in early American manufacturing did so much to promote it. Although he did not subscribe to any of the stock of the Paterson company, his advice and influence were most potent in assisting the men who were able to undertake the work.

The first meeting was held Nov. 22, 1791, at New Brunswick, N.J., and a company formed called the Society for the Establishment of Useful Manufactures. The following directors were elected: William Duer, John Dewhurst, Benjamin Walker, Nicholas Low, Royal Flint, Elias Boudinot, John Bayard, John Neilson, Archibald Mercer, Thomas Lowry, George Lewis, More Furman, and Alexander McComb, many of whom were not only prominent citizens of New Jersey, but several of whom had a national reputation.

The principal purpose was the production of cotton yarn and cotton fabrics, although the company contemplated the manufacture of other useful articles. Nehemiah Hubbard, Esq., of Middletown, Conn., was appointed general superintendent with a salary of two thousand dollars a year. Advertisements for sites were printed in the papers of New York, Philadelphia, and Trenton, and finally a committee was appointed to fix the seat of manufacture. It was finally voted by the committee, May 17, 1792, to locate

the new industry and the new town at the Great Falls of the Passaic, where the Passaic River breaks through the range of hills that rise about five hundred feet and are known as the Orange Mountains, and then flows into what is the lower part of New York Harbor.

The Great Falls had an elevation of one hundred and four feet above tide-water and were capable of driving two hundred and forty-seven water wheels. Here the company bought seven hundred acres of land for \$8,230, and, although some of the directors were in favor of calling the place after Hamilton, they named the future town Paterson in honor of William Paterson, Governor of the State of New Jersey.

Resolutions were adopted for erecting a cotton mill and buildings to accommodate workmen. Appropriations were made of \$20,000 for the construction of a canal, \$5,000 for the cotton manufactory and machinery, \$12,000 for the print works, and \$5,000 for the weave-shop and equipment.

The comfort of their employees was also considered by the directors of the company, for fifty houses for workmen, twenty-four feet by eighteen feet, with a cellar and garret, were to be built, at a cost of about two hundred and fifty dollars each. Any mechanic, married and of good character, was to have the privilege of leasing the house on a long term of years or of buying it on the instalment plan.

The company on the 18th of July, 1792, advertised for contracts to build a canal thirty feet wide and a dam above the Great Falls to be four feet high and for the erection of four stone mills and fifty houses, the units being two houses under one roof with a parting wall. According to the minutes of the meeting held Oct. 1, 1792, the paid in capital amounted to \$160,000.92, of which \$14,139.87 had been spent for the purchase of land, grist and saw mill, \$7,500 for machinery, materials, and implements, and \$12,545.43 for building materials, salaries, and wages.

Mr. Hubbard was soon succeeded by Major L'Enfant, a French engineer who had been with Napoleon and who

had surveyed and laid out the city of Washington. Major L'Enfant's ideas, however, were on such a grand scale and so impractical that he was soon succeeded by Peter Colt, who had been comptroller of the State of Connecticut and interested in the Hartford Woolen Manufactory. Colt took charge in February, 1793. A wooden building for temporary occupancy was built, the cotton machinery being run at first by ox-power until the water-power equipment could be completed, and so for many years the building bore the name the "Bull Mill."

The permanent mill, which was completed in the summer of 1794 and which was about on the site of where the silk mill of Hammel & Booth stood, was of stone, ninety feet long, forty feet wide, and four stories high. According to the *Connecticut Journal* of July 2, 1794, the spinning of cotton by water power began June 14 of the same year. The dam and canal had been completed, and the mill was opened with a parade and a ball, which was given at the factory. The equipment of the factory seems to have been four carding machines, twenty-five spinning jennies, and sixty single looms. It employed a hundred and twenty-five operatives.

The enterprise, however, was not a success. The extravagant constructive work, together with the mismanagement said to have been due to an improper use of the funds by some of the officers, led the stockholders to refuse to pay further instalments on their subscriptions, and finally on Jan. 26, 1796, a resolution was adopted that the superintendent be directed to stop all manufacture as soon as goods in hand could be finished and to discharge the help. Mr. Colt asked for his dismissal, and it was granted March 7, 1797.

The factory remained unoccupied until 1800. John Park then turned it into a mill for making candlewicking. According to James Beaumont, an Englishman who visited Paterson to buy machinery in the spring of 1801 and who

visited the cotton factory, it was nearly full of machinery of a costly kind, the billets of the carding cylinders being covered with mahogany. The machines did not seem to have been worked, and apparently John Clark, who later engaged in machinery manufacturing in Providence, was using the basement story for making textile machinery. Clark continued to occupy the basement of the factory until the factory was burned in 1807.

Since this date the Society for the Encouragement of Useful Manufactures has not operated any mill of its own, but the stock has acquired much value because the company has retained its real estate and rights to the water power, which have been used to develop the subsequent textile industries as well as other manufacturing operations in Paterson.

The establishment of the silk industry in Paterson has already been referred to in the chapter on silk, but these further details complete the story. The first silk mill started by Christopher Colt, Jr., of Hartford, was a small affair, and was bought in 1840 by G. W. Murray, of Northampton, who put in charge John Ryle, an English silk weaver from Macclesfield, England.

Ryle became a partner in 1843, the firm being Murray & Ryle, and in 1846 Ryle with his two brothers who came from England bought out Murray and began weaving dress goods. Although the silk was of excellent quality, it could not be made at a profit, and he devoted his mill to tram organzines, spool silks, and trimmings. Later, when his sons became associated with him, he successfully took up the making of twills and fancy silks. Ryle has been called the father of the Paterson silk industry. Other mills started in a small way in Paterson, and little by little the industry grew until the output has reached the present proportions, which, according to the last census, was \$50,000,000 annually.

NEW BEDFORD

The beginning of the textile industry at New Bedford, like the development at Lawrence, was due to the enterprise of one man, whose persistence in carrying out his purpose overcame all obstacles.

About 1840 Dwight Perry had left Fairhaven, which is across the river from New Bedford, and had started in Georgia a small cotton mill, having as one of his employees Thomas Bennett. Becoming desirous of having his own business, Bennett returned to New Bedford, and endeavored to interest New Bedford capital in starting a mill in Georgia. He persuaded William T. Russell in 1846 to go to Georgia with him to look into water power and mill sites, and on their return tried unsuccessfully to secure New York capital for the enterprise.

Meeting Joseph Grinnell, who was a Congressman from New Bedford, Bennett and Russell interested him, but he refused to take part in the plan unless the mill was built at New Bedford, where those who invested might watch the progress of the enterprise.

The opinion of David Whitman, who was a mill expert and was engaged in cotton manufacturing at Warwick, R.I., was sought, and his favorable opinion of the success of building a mill at New Bedford led Grinnell to back Bennett's project. It was decided to raise three hundred thousand dollars, and to build a mill with three hundred spindles. New Bedford's capital at the time was tied up in the whaling industry, which was then at its height and paying large profits, and the holders of money were very loath to put their capital into such an uncertain venture as a new cotton mill in New Bedford. Not only was the sentiment of the citizens against the project, but the mechanics of New Bedford were opposed to it, because they thought that mill work with its organized and regular business would be inimical to them. Only \$157,900 could be

raised, and that in small subscriptions ranging from ten to a hundred and fifty shares. Grinnell, who had subscribed for \$10,000, took \$2,100 more, making \$160,000, with which it was decided to start.

A charter was granted April 8, 1846, for the Wamsutta Mills, Matthew Luce, Jireh Perry, and Thomas S. Hathaway being the incorporators. Joseph Grinnell was chosen president; Edward L. Baker, treasurer; and Joseph Grinnell, David R. Greene, Thomas Mandell, Joseph C. Delano, and Pardon Tillinghast, directors. Thomas Bennett was made superintendent. Carpenters, mechanics, and operators had to be brought from Rhode Island, Connecticut, and the central part of Massachusetts; and all the material but the building stone, and some of that, had to be transported from Fall River. Boarding-houses and tenements were to be constructed for the employees. At a stockholders' meeting held June 9, 1847, it was voted to buy a tract of land with power, south of Benjamin Rodman's, for \$7,500, as fresh water and railroad and shipping facilities were at hand.

Mill No. 1, designed for fifteen thousand spindles and three hundred looms, was built, but only ten thousand spindles and two hundred looms put in. It was completed in 1848, and manufacturing began Jan. 1, 1849. Bennett recommended Wamsutta shirtings, and they have since been sold all over the world.

In 1849 the capital stock was increased to three hundred thousand dollars, and five thousand more spindles and one hundred more looms put in. The first dividend was declared Feb. 1, 1850. Slowly, but surely, the business increased, and even the Civil War did not close the mill. Although the mill was very successful, it was not until 1871, over twenty years after the starting of the Wamsutta Mill, that the second mill, the Potomska Mill, started. In the mean time, mill after mill had been added to the Wamsutta, and dividend after dividend had been



INTERIOR VIEW OF A MODERN WEAVE-ROOM
(Courtesy of the Chicopee Manufacturing Company)

paid, until the original stockholders had received over 300 per cent. on their money. The Acushnet followed in 1881, and the New Bedford and City Manufacturers in 1882. Mill after mill has been erected, until there are now over fifty mills which turn out the best grade of cotton goods, to which the climate of New Bedford is peculiarly adapted. It is said to be more like that of Manchester, England, than any other American city. In 1911 the city had 2,939,884 spindles and 54,282 looms, supplying 31,140 workmen. There were sixty-seven cotton mills with a capital of \$36,821,300. In 1912 the population of New Bedford was 105,000, which turned out, according to the last census, \$44,000,000 worth of goods.

MANCHESTER

Like Lowell and Lawrence, Manchester, N.H., was a "manufactured" town that was originally owned and developed by the mill which bought the water rights and first started its spindles in the locality. And, as Lowell and Lawrence had far-sighted and fearless merchants whose imagination could see the possibilities of a remote future, so Manchester had men of the same stamp, the first of whom was Samuel Blodgett.

Blodgett, who was born in Woburn, Mass., had served as sutler during the Revolution, had been a judge of the Court of Common Pleas and a merchant, when in 1793 he went to live at Derryfield on the east bank of the Merrimac, near Amoskeag Falls. He built a canal to carry lumber around the falls, and completed the work May 11, 1807. Appreciating the great power of the water, he endeavored unsuccessfully to interest Boston capital in mill development, which he saw could be readily compassed. He died soon after the completion of the canal, and it passed into the hands of the Middlesex Canal. In June, 1810, the name Derryfield was changed to Manchester in honor of Judge

Blodgett, who had said that the site would be the Manchester of America.

Early in 1809 Benjamin Pritchard, who had learned his trade at New Ipswich, and had come to Bedford and spun cotton on the old Goffe place, with Ephraim, David, and Robert Stevens built a cotton mill on the west side of Amoskeag Falls, in what was then called Goffstown. As the financial burden was too heavy for them to carry alone, a joint stock company was formed, and the first meeting was held Jan. 31, 1810, as "The Proprietors of the Amoskeag Cotton and Woolen Factory." In June of the same year they incorporated as the "Amoskeag Cotton & Wool Manufactory."

The incorporators were James Parker, Samuel P. Kidder, John Stark, Jr., David McQuestion, and Benjamin Pritchard. Parker was president, and Jotham Gillis was clerk, and later agent. The original mill was a pygmy compared with the great structures of to-day, for it was but forty feet square and two stories high. It had no cotton picker, the cotton being ginned in the neighborhood and by the farmers' wives at four cents per pound, and the machinery consisted of only spindles, the cotton spun being either woven for the mill by the housewives in the neighborhood or sold at the mill.

The machinery ran until 1816. Lack of business then stopped the spindles, and they remained idle until 1822, when Olney Robinson, of Attleboro, Mass., bought the property, and work was resumed. Subsequently it was sold to Larned Pitcher and Samuel Slater, of Pawtucket, and in 1825 they sold three-fifths of the property to Willard Sayles and Lyman Tiffany, of the firm of Sayles, Tiffany & Hitchcock. Dr. Oliver Dean became agent of the company, and in 1826 a new mill was built, called the "Bell Mill," and another on an adjacent island, and the company commenced to make the sheetings, ticking, and shirtings that since have made the Amoskeag Mills famous. The engineer who laid out the new mill was Ezekiel Straw, who also laid out the Amos-

keag Locomotive Works and who built the first fire-engine. He was agent of the Amoskeag Mills for a great many years, and did much to lay the foundations of their great prosperity.

The company was again incorporated July 1, 1831, as the Amoskeag Manufacturing Company by Ira Gay, Willard Sayles, Oliver Dean, Larned Pitcher, and Lyman Tiffany, who also acted with power of attorney from Slater, and the capital was a million dollars. Tiffany was chosen first president; Ira Gay, clerk; and Oliver Dean, agent and treasurer. Tiffany, Gay, and Sayles became directors.

AMOSKEAG LAYS OUT A TOWN

The new corporation bought all the water power along the Merrimac from Manchester to Concord and all the land available for building sites in Manchester. The town was laid out by the Amoskeag Company, streets and public squares being made; and in 1838 part of the land was divided into lots, and sales began for stores and dwelling-sites. Boarding-houses and tenements were built for their employees, and land was sold and water privileges leased to other corporations. And thus the city of Manchester, N.H., was founded by the Amoskeag Company. The pay of the early agents was \$180 per year, and outside weavers received thirty-six cents per day. The second mill, the Stark Mill, was incorporated Sept. 26, 1836, with Nathan Appleton as president. In 1830 Manchester had but 877 people, and by the 1910 census it had 70,063. The gross value of the total output of textile products during the year, according to the last census, was \$23,000,000.

NEW YORK

The burghers of early New York were as proficient in the handicraft of the home as were the Puritans of New England, and among these handicrafts homespun spinning and

weaving held the principal place. Throughout the colonial era, evidences of the industry in the homes of New Amsterdam are numerous, but, although the city early made strenuous efforts to compass the establishment of the industry in a sense that could be called manufacturing, the industry never obtained so strong a hold as it did in New England because of the lack of water power.

A society called the Society for the Promotion of Arts, Agriculture, and Economy was formed in 1764 to encourage the manufacture of linens. Another organization was formed later, the members of which pledged themselves neither to buy imported cloth nor to eat the meat of sheep or lambs less than two years old. Homespun raiment became quite the vogue. Governor Moore in 1767 reported for New York that there were two kinds of wool being made there: one class of all wool; the other linsey-woolsey, of linen in the warp and wool in the weft.

Soon after the Revolution the industrial development of the city engaged the attention of its residents, and late in 1788 an organization called "the New York Society for the Encouragement of American Manufactures" was formed to carry out this purpose. At one of the first meetings, held Jan. 5, 1789, at Rawson's Tavern, it was unanimously resolved to raise a fund to promote the objects of the society, and a constitution adopted at a later meeting designated the purpose of the society as that of establishing house manufactures in the city of New York, furnishing employment for the honest and industrious poor, and named the organization the New York Manufacturing Society. The treasurer was Alexander Robertson.

An advertisement was inserted in the *New York Journal* for a manager and superintendent to take charge of the manufacturing, and on the 3d of July, 1789, notice was given that the society was ready to do business on its bleach-ground at Mill Hall, Second River, N.J., and that linen cloth and yarn would be taken in to bleach either there or

at the factory, 21 Crown Street. It was further announced that good weavers would be furnished with looms at their own houses if they would apply at the factory.

A later advertisement shows that a Mr. Stevenson was then the manager, and that brown linen sheeting, linen yarn of the first quality, hatchelled flax, tow, and backings, were being sold at the factory in Vesey Street, to which it had been removed. By Dec. 23, 1789, fourteen weavers and a hundred and thirty spinners were at work. Cotton machinery had been started at this date.

In a letter Moses Brown received from Samuel Slater, who was employed in the factory during the months of November and December, 1789, Slater said that the factory had but one card, two machines, and two spinning jennies, and they were very inefficient. On the 3d of August, 1789, the directors ordered small notes to be struck off, of one, two, three, four, and five pence and up, which they issued to their employees and received in payment for goods purchased at the factory, and bound themselves to exchange at all times for gold or silver or paper currency of the State.

An advertisement which appeared on Dec. 11, 1790, shows that the manufacture of cotton yarns and cloth, as well as linen, was under way. The cotton and linen sheetings had undoubtedly a linen warp and cotton filling. The business, however, did not prosper, and for a number of months subsequent to May 9, 1793, the factory was offered for sale or lease.

There seems to have been no further effort at an establishment of the industry until about July 30, 1793, when David Dickson and others on New York Island, on the bank of the East River opposite Hell Gate, took steps to start the manufacturing firm of Dickson, Livingston & Co. by mortgaging for three thousand dollars twenty-eight acres of land with houses, mills, and buildings at this place. It is not known at what time they began manufacturing, but it may have been early in 1793. According to a description

given by an English clothier who visited the factory in 1794, it was known as Dickson's Cotton Factory, and was worked by a breast water wheel twenty feet in diameter. There were two large buildings, four stories high and eighty feet long. Twenty-six looms were at work, weaving fustians, calicoes, nankeens, nankinettes, dimities, etc. Ten looms were being operated in the neighborhood, and the Arkwright system of spinning was being worked by twelve or fourteen workmen from Manchester. There were twenty or thirty women and children at work. The women were making two dollars a week with their board and lodging. This shows that as early as 1794 not only was the Arkwright system being used, but the Crompton mule, at a date at least ten years earlier than most authorities have fixed the first use of the mule in this country. Already in 1793 John Daniel, a European mechanic, had established himself in New York City, where he had commenced the construction of carding machines of all kinds; also the new invented machines for cleaning seed cotton, etc.

The power supplied to the Dickson mill came from the breast wheel that was driven by water from a reservoir having a fall of some ten feet, the feeder of the reservoir being a brook flowing from the hills in the interior of Manhattan Island. If a tide wheel was used, it was solely for the purpose of pumping water into the reservoir during the dry season of the year. The business seems to have been conducted until the close of 1793 as the New York Cotton and Linen Manufactory. According to Samuel Batchelder the machinery was in full operation in 1795. The property was, however, sold Dec. 26, 1799.

These early attempts at the textile industry on the Island of Manhattan demonstrated that it was not feasible ever to establish much of a textile industry in the city of New York. As late as 1824 the county of New York contained but three fulling mills, five carding machines, and two cotton and woolen factories. Its greatest development has been in

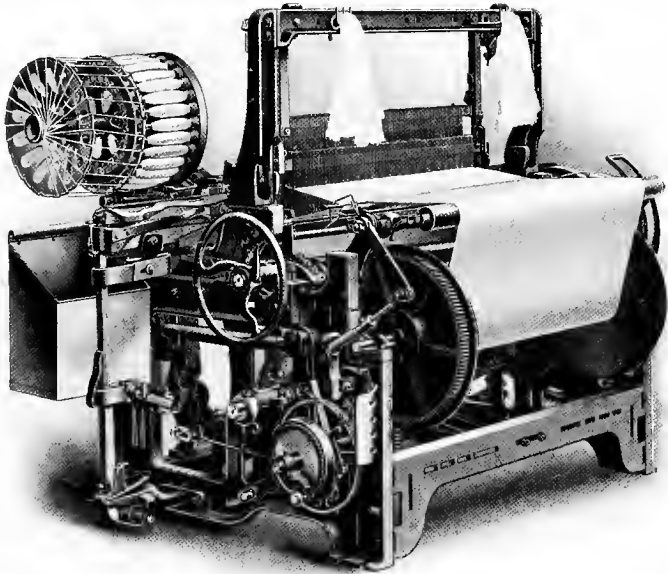
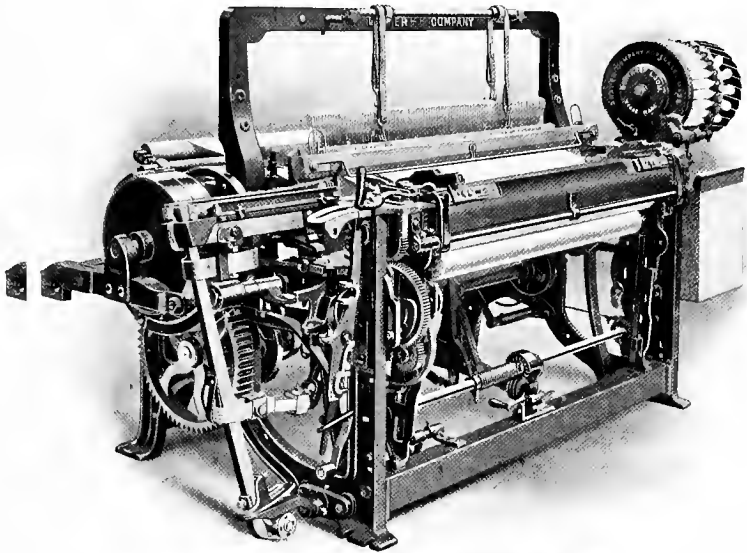

MODERN AUTOMATIC NORTHROP LOOMS
(Courtesy of the Draper Company)

the cutting up trade and the manufacturing of clothing, to which lines of industry it owes its prominence as a textile centre to-day. According to the census these industries have grown to a size which makes New York to-day the leading city of America in the cutting up lines, the gross value of its textile products, according to the 1910 census, being \$52,000,000.

AMSTERDAM

The rugged figure of Sir William Johnson, the famous pioneer of middle New York, looms in the background of the history of Amsterdam, Montgomery County, N.Y. He it was who built the saw-mill on the Chuctenunda River, which was the beginning of the Amsterdam industry, and which later was one of the sites of the early textile mills. Johnson bought the property about Amsterdam in 1742, and utilized the water power of the river in the mill. The little hamlet, which was settled about 1775 and was called Veedersburg, grew slowly. In 1814 its present name was adopted, but it was not until 1885 that it was chartered as a city. In 1813 it had two carding and two fulling machines. In 1814 the Star Hosiery Mills of H. Pawling & Sons were commenced by Pawling and Jackson, in which woolen goods were manufactured.

Wait, Greene & Co. in 1840 had leased a small satinet factory at Hagaman's mills, near Amsterdam, and commenced to make ingrain carpets. Two years later the partnership was dissolved, and W. R. Greene went to Amsterdam proper, and in a small building set up the first carpet looms in the town. John Sandford became interested in the place, a larger structure higher up the creek was bought, and the business grew rapidly, particularly under the direction of Stephen Sandford, a graduate of West Point and son of the original owner.

W. R. Greene and John McDonnell commenced in 1857 the manufacture of knit goods with two sets of machines.

The same year Adam Kline and John Maxwell commenced making knit goods. Later Kline sold his interests to Maxwell, and started in business with his son. The Pioneer Hosiery Mills were built in 1868, and since then the textile industry in Amsterdam has grown rapidly. Its most important industries are carpets, rugs, hosiery, and knit goods. Its output, according to the last census, was \$17,000,000.

WOONSOCKET, R.I.

The falls of the Blackstone and its tributaries, the Mill and Peters Rivers, in the vicinity of what is now Woonsocket, offered an opportunity for an early establishment of the textile industry, as here the falls were about thirty feet. In 1810 the water rights were owned by James Arnold, Stephen Wilcox, and Joseph Arnold. The latter had inherited his land from his grandfather Daniel Arnold, one of the early pioneers.

On Oct. 24, 1810, a meeting was called, at which Ariel Abner, Nathan Ballou, Eber Bartlett, Job and Luke Jenckes, Oliver Leland, and Joseph Arnold formed the Social Manufacturing Company, and divided the stock into sixteen shares of a thousand dollars each, each stockholder taking two shares of stock. Cotton yarn and cloth were to be made. About four acres of land were sold to Mr. Arnold, and a small wooden mill erected that contained two thousand spindles.

James Arnold built a mill in 1814, and here Dexter Ballou began to spin cotton. The building was conveyed Oct. 8, 1821, to Daniel Lyman, and has since been known as the Lyman Mill. Dexter Ballou came to Woonsocket in 1817. Previously he and his father had been working at Ashton, near what was known as the "Sinking Fund." The machinery consisted of five cards made by Dexter Ballou, and three spinning jennies of eighty-four spindles each. The machinery was later removed to Lynn, Mass. When

Daniel Lyman bought Joseph Arnold's mill, he also bought Ballou's cotton machinery.

Jenckes sold out his interest in 1822, and built at Peters River, at what was Jenckesville, the first stone mill in Woonsocket. In 1827 the second wooden mill was built. Dexter Ballou became sole proprietor Nov. 12, 1841, and the following year the Stone Mill was enlarged and improved. It was very successful under the management of Orin A. Ballou, president, Henry Lippitt, treasurer, and Charles Nourse, superintendent. July 1, 1874, the mill was burned. Woonsocket became a city in 1888, and to-day its principal textile products are worsted and woolen yarns, woolen and cotton goods, and cotton yarn and silk. Its population is about thirty-eight thousand, and its output, according to the last census, was \$20,000,000.

CONCLUSION

The establishment of the textile industry in the textile centres of America marks the end of this brief survey of the methods by which man has clothed himself. The survey has dealt largely with the era from 1733, when Kay invented the fly shuttle, to about the death of Samuel Slater a little over a century later, because during this period the industry has shown its greatest development, and this century marks the transition of the industry from a handicraft in the home to a power production in the factory.

This transition has had a far-reaching effect on social conditions on both sides of the Atlantic. It has changed the face of Western England from an agricultural section to a great manufacturing centre, whose mills and factories have brought about a segregation of population in industrial centres, and has created the great middle class in England. It has given labor in England a dignity that it never possessed, and has placed many of the great captains of industry on a plane of equality with the nobility. Many of

the Lancaster mill owners who have played such a potent part in the politics of Great Britain for the last hundred years have risen from the ranks of the workers or have been descendants of workers in the textile mills.

The industry has been the leaven which has expanded the intellectual vision of the industrial worker to a point that has made him a factor in the politics of his nation and a coming power in the great movement for the betterment of the world; for the English textile worker has learned to sympathize with the fellow-worker of another nation as well as with workers in other classes of industry.

The transformation on this side of the Atlantic has been quite as interesting, though perhaps along somewhat different lines. It was during the colonial era and up to the beginning of the nineteenth century a handicraft in the home, as it was in England and on the Continent,—a handicraft that was limited in output and impotent in its influence on the social life of its time.

The introduction of machinery caused the harnessing of the rocky streams of New England to spinning frames and looms, and stimulated the inventive genius of the Yankee. The concomitant adoption of Arkwright's machinery and Lowell's and Gilmore's perfected looms in American mills caused an extension of the industry not only over the rocky face of New England, but even into the cotton-growing fields of the South and along many of the less rugged streams of the Middle Atlantic States.

The industry found New England a great maritime centre, sending its ships for trade to the uttermost parts of the earth. It stimulated and developed the great shipping interests during the middle of the nineteenth century; for its cotton goods found a ready market in the East, and at that time so much greater were the returns from the capital invested in the textile mills of New England that money was diverted from the shipping interests into mills, and during the end of the last century to the more profitable in-

vestments in transportation and in the fast-growing West. To-day the shipping has disappeared and the textile industry has dotted the face of New England with the great mill centres, which are beehives of production, whirring with millions of spindles, clattering with thousands of looms, and rumbling with thousands upon thousands of pulleys and shaftings, turning out millions of dollars' worth of fabrics of every description.

The growth in America has indeed been phenomenal, for prior to 1787 there were few spindles under one roof, and very few in the country as a whole. With the establishment of the Pennsylvania Society for the Encouragement of Useful Arts and the Beverly Cotton Manufactory, the two earliest cotton manufactories, there were not in all in 1788 more than 860 spindles in America. According to the 1910 census the number of spindles is now 33,998,648, of which 28,178,862 were employed in the cotton industry, 2,156,849 in the woolen industry, and 1,752,806 in the worsted, and 1,767,962 in silk, and on flax, hemp, jute, and allied fibres 142,169. The census ranks the textile industry on the basis of the value of output second only to that of food products; while, as to the number of employees, it gives it the first place; as to the number of establishments, fourth place; and as to capital, salaries, and wages, second place.

The total capital invested in the textile industry in this country to-day is \$1,343,324,605. There are 1,154 mills devoted to cotton, 1,213 to wool, 1,079 to knit goods, and 624 to silk. 739,239 wage-earners are engaged in the industry, who draw \$249,357,277. Its salaried officials and clerks number 24,116. The cost of the material used is \$745,783,168, and the value of the product is \$1,215,036,792.

Hardly less marvellous than the growth of the industry has been the increased production of the individual spinners and weavers. As Jonathan Thayer Lincoln well says, in the admirable little monograph "The Factory," of the con-

dition of the industry after the establishment of the factory system, "The amount of labor performed in a single factory was as great as that which formerly gave occupation to the inhabitants of an entire district." He says that while originally a good hand loom weaver could produce two pieces of shirting each week, by 1823 a power loom weaver was able to produce seven such pieces in the same time, while a factory of two hundred looms operated by one hundred persons could, it is estimated, weave seven hundred pieces a week. Under the old handicraft system at least 875 looms would have been required to weave the same amount of cloth. He estimates that the work done in a steam factory containing two hundred looms would, if performed by hand, give employment and support to a population of two thousand persons, and that a modern weave-room, containing two hundred power looms operated by twenty-five weavers, is equivalent to the labor of a community of sixty thousand craftsmen, their wives and children. So that to produce by hand the work now turned out by the Fall River factories alone would require a population of thirty million.

A further estimate by John S. Lawrence shows that the productiveness of the individual weaver and spinner as compared with the old handicraft workman has been increased over a thousand times, and, as the consumption continues to increase in equal ratio, we must in the future either increase the production of labor and machinery or employ a greater per cent. of the population.

The social changes brought about by the textile industry in New England have been almost as marked as those in England. At first the mills were made up almost wholly of the sons and daughters of native-born Americans, often neighbors and friends and almost always acquaintances of the proprietor. As the industry grew, calling for more help, Irish and French-Canadians came in, driving out with their cheaper labor the native-born, and this together with the offering of the mill stock on a wider scale resulted in a dis-

continuance of this close working relationship between employee and employer, until it was not long before the employers, or the stockholders, were entire strangers to the body of employees. The French-Canadians in turn were driven out by the hordes of emigrants from Russia, Poland, Bohemia, and the southern countries of Europe,—a class unfamiliar with American ideas or American standards of living. This last class of help has done a great deal to change the civic conditions of the factory towns and to lower the standard of living. Hours and conditions of work are, on the other hand, constantly improving. As more and more of the mill owners are showing a regard for their employees, outside as well as inside their factories, the general conditions in the mill towns are improving, and the day is rapidly approaching when the criticisms of the present mill town conditions will not apply.

The textile industry is so highly competitive and the development of machinery has produced such excellent work with but little skill that the textile mills of New England have become great training schools in industry for the most recently arrived immigrants from the less resourceful nations of the whole world; while in the South the industry has lifted to a plane of greater comfort and efficiency the natives who even before the war were completely poverty-stricken. Not only have the mills trained the employees and their children so that former textile employees now form the part of our great middle class which operate our industries everywhere, but they have also furnished the means by which they and their children have been fed, clothed, and educated.

The Statute Books of many of the more advanced States, such as Massachusetts, Rhode Island, and Pennsylvania, already contain admirable laws aimed to remove the causes of friction between the employees and the mill owners and the public. Many mills are taking steps not only to safeguard their employees while at work, but to promote their

happiness and to better their living conditions. And, as soon as a community is able to feed and clothe its children and endure taxation for education, the employment of children will cease. Many who have for hire, either capital or labor, are beginning to realize that theirs is a trust given them temporarily, not alone for their own benefit, but for the interests of the community; and employers and employees who act in accord with this realization are the effective forces in making the future of the country better for all.



Reproduction of the original engraved copperplate of Samuel Wetherill, of Philadelphia, the first manufacturer of velvets, jeans, fustians, and other cloths in America, used by him as early as 1782 to print cards and labels for his manufacture.

INDEX

- Abbott, J. G., stockholder, 219.
Acme Spinning Company, first to use electric power, 69.
Acushnet Mills, *New Bedford*, 239.
Adair, James, 113.
Addison and Stevens, of *New York*, patent a ring spinner, 109.
Agriculture, its relation to the English textile industry, 62, 64-65.
Alabama, consumption of cotton, 43.
Alcohol, used for fuel, 91.
Alexander, *the Great*, brings knowledge of silk-making to Europe, 46.
Alexander, Joseph, weaves corduroy at Providence, 162, 230.
Algonquin Indians, weaving by, 22.
Alizarine, produced artificially, 118.
Allen, John, establishes cotton mill at Centreville, R.I., 178.
Almy, Brown and Slater, *Providence*, partnership formed, 171; construct Arkwright machinery, 172; seek government aid, 173; use cotton warp, 173; build "Old Slater Mill" for spinning, 174; payment and discipline of employees, 174; markets for yarn, 174-175, 176; buy Centreville cotton mill, 178.
American colonies, silk industry in, 51-52.
American Linen Company, *Fall River*, 229.
American Manufactory, *Philadelphia*, earliest cotton and woolen manufactory in America, 215.
American Print Works, *Fall River*, largest in America, 228.
American Printing Company, *Fall River*, 228.
American Woolen Company, 221.
Ammianus Marcellinus, cited, 47.
Amoskeag Manufacturing Company, incorporated, 241; lays out Manchester, 241; wages of employees, 241; growth of the industry, 241.
Amsterdam, N. Y., a textile centre, 210; value of product, 211; history of, 245-246; hosiery mills, 245, 246; carpet mills, 245; knit goods, 245; value of output, 246.
Aniline dyes, discovery and nature of, 118.
Anthony, Daniel, manufactures cotton in Rhode Island, 161, 230.
Anthony, Richard, makes textile machines, 161.
Appleton, Nathan, meets Lowell in Edinburgh, 193; sells Waltham goods, 197; names Lowell, Mass., 205; stockholder of Essex Company, 220, 221; president of the Stark Mill, 241.
Appleton Company, established, 209.
Apprentice system, 65-66; tried by Slater, 174.
Argentine Republic, production of wool in 1909, 31.
Aristotle, cited, 46.
Arkwright, Richard, the "father of the factory system," 68, 69, 73; erects first practical cotton mill in the world, 68; sketch of, 78-83; Carlyle's description of, 79; early life, 79-80; his spinning frame and other inventions, 80-81; his machines destroyed, 82; infringement of his patents, 82; knighted, 83; his machines first used in America, 173, 244.

- Arnold, Asa, invents Compound Gear, 108.
- Arnold, James, builds mill at Woonsocket, 246.
- Arnold, Joseph, starts Woonsocket cotton industry, 246.
- Arrian, mentions cotton, 36.
- Atlantic Cotton Mills, *Lawrence*, 221.
- Aurelian, *Emperor*, calls silk extravagant, 47.
- Australia, production of wool in 1909, 31.
- Bailey, John, makes textile machines, 161.
- Baldwin III., *Count*, establishes first weavers at Ghent, 22.
- Ballou, Dexter, constructs textile machines at Woonsocket, 246-247.
- Baltimore, *Md.*, manufacturers petition for duty on cotton, 188; cotton manufactory established, 188-189.
- Bancroft, Edward, perfects dyeing machinery, 118.
- Barbadoes, exchanges cotton and rum for slaves, 127.
- Barr, Robert and Alexander, receive aid from Massachusetts for textile machinery, 151, 152, 153; "The State Models," 153.
- Barrett, Charles, proprietor of New Ipswich Mill, 179.
- Bartlett, Edmund, founder of the Essex Company, 220.
- Basket weaving, in ancient times, 14, 15-16; at Wellfleet, 22.
- Basyer, produces artificial indigo, 118.
- Batchelder, Samuel, invents the stop-motion, 109; quoted, 244.
- Bay State Mills, *Lawrence*, 221.
- Bayeux tapestry, 26.
- Beaumont, James, cited, 235.
- Bell, John, invents power loom, 106.
- Bell, Thomas, discovers plate and cylinder printing, 120.
- Belts, leather, first used at Lowell, 110.
- Bennett, Thomas, tries to start cotton mill in Georgia, 237; decides to try New Bedford, 237; superintendent of the Wamsutta Mills, 238; success of his enterprise, 238-239.
- Berthollet, Claude Louis, his experiments in bleaching cloth, 114; experiments in dyeing, 117.
- Beverly, *Mass.*, early cotton mill, 179.
- Beverly Cotton Manufactory, may have been first cotton mill in America, 149, 150; instigated by the Bridgewater experiments, 153-154; incorporated, 155; raw cotton imported, 154; secures a trade-mark, 155; the mill erected, 155; described, 156; expenditures, 156-157; legislative grant, 157; visited by Washington, 157-158; first textile advertising, 159; Beverly corduroys, 159; the industry discontinued, 159.
- Bible, mentions textile art, 17; flax, 26; cotton, 36.
- Billston, James, earliest reference to English cotton manufacture, 37.
- Bishop, John Leander, his "History of Manufactures," cited, 131.
- Blackman, Charles, early tailor, 212.
- Bleaching, history of, 111-115; bleaching with milk, 112; in the sun, 113, 176, 208; laws against stealing of linen, 113; premium offered in Scotland, 113; Home's sulphuric acid process, 113-114; the chlorine process, 114-115; method of at Slater's mills, 176.
- Block printing, process of, 119-120, 232. *See also* Printing.
- Blodgett, Samuel, builds canal at Derryfield, 239; tries to develop the water power there, 239; Manchester named in honor of him, 239-240.
- Board, his experiments in dyeing, 117.

- Bombyx, 46, 47.
- Bonvoise, Anthony, introduces the distaff into England, 71.
- Boott, Kirk, secures water privileges for Lowell mills, 201; song written about him, 201; his life and personality, 202; attempts upon his life, 202; treasurer of the Merrimac Company, 203, 204; secures engravers in England, 205.
- Boott Company, established, 209.
- Borden, Holder, 228.
- Borden, William, receives bounty on duck, 133.
- Boston, Linen Manufactory House established, 134; Linen Men's House, 134; spinning craze, 135-137; Manufactory House on Tremont Street erected, 137; Society for Promoting Industry and Frugality raise money for spinning, 136; young women spin on the Common, 136; Frog Lane, now Boylston Street, 160; Holyoke, now Tremont Street, 160.
- Boston Manufacturing Company. *See* The Waltham Company.
- Boston Sail Cloth Factory, history of, 159-160; described by Washington, 160.
- Boulton, Mathew, partner of James Watt, 100.
- Bourne, E. A., 221.
- Bow, *Eng.*, early dye works there, 117.
- Bowditch, William, comments on the Waltham speeder, 195.
- Bowdoin, *Mr.*, examines textile machinery, 151.
- Bowers, *Mrs.* Isaac, sells Waltham goods on Cornhill Street, 197.
- Branch, Peter, his inventory mentions home-made cloth, 123.
- Brazil, production of cotton, 35; natives use cotton in 1519, 40.
- Brewster, Gilbert, invents the Eclipse Speeder, 109.
- Bridgewater, *Mass.*, early textile machines made there, 151-153, 161.
- Brooks, Daniel, erects cotton mill, 179.
- Broome, Jacob, his cotton mill, 190.
- Brown, Jeremiah, commission merchant, 176.
- Brown, John, directs Boston spinning school, 137; refuses to be dispossessed, 137.
- Brown, Moses, of *Beverly*, founder of the Beverly Cotton Manufactory, 155.
- Brown, Moses, of *Providence*, seeks the co-operation of the Beverly proprietors, 159, 173; buys textile machinery, 162; invites Slater to Providence, 170; quoted, on Slater's cotton warp, 173.
- Brown, Obadiah, buys cotton mill at Centreville, 178.
- Brown, Smith, buys Fullem's stocking loom, 162; forms partnership with Samuel Slater, 171.
- Buckram, manufactured in 1722, 132.
- Bush, Thomas, 180.
- Button, John, makes children's hose, 218.
- Byfield, Newburyport Woolen Manufactory established, 165-166.
- Cabot, Andrew, 155.
- Cabot, Deborah, 155.
- Cabot, George, letter to Alexander Hamilton quoted, 149, 154, 156; one of the founders of the Beverly Manufactory, 155; entertains Washington, 157-158.
- Cabot, Henry, anecdote of Washington's visit, 157.
- Cabot, John, purchases site of Beverly Manufactory, 155.
- Calico, brought from India, 36, 38; woven by Arkwright, 81; printing of, 119; first in America printed by John Hewson, 140, 215; printing in Rhode Island, 162; printed at Lowell, 205, 206.
- Cam, John, stocking weaver, 212.

- Cap Spinner. *See* Danforth, Charles.
- Capital, combination of, cause of modern factory system, 60, 66, 67.
- Carding machine, Kay's, 74; Paul's, 77; Crompton's, 86; constructed by Earl, 172; manufactured at Philadelphia, 215-216; constructed by John Daniel, 244.
- Carlyle, Thomas, his essay on Chartism cited, 69; quoted, 79.
- Caroline, *Queen of England*, has dress of Georgia silk, 52.
- Carpenter, Ezekiel, his fulling mill at Pawtucket, 172, 173.
- Carpet, industry in Philadelphia, 216-217, 218; first manufacturer of, 216; Turkish and Axminster, 216-217; floor carpets and oil cloths, 217; Brussels, 217; industry in Amsterdam, N.Y., 245, 246.
- Cartwright, Edmund, 69, 73; sketch of, 88-92; his power loom, 88-90, 91; early life and education, 90-91; his personality, 91; his other inventions, 91-92; his machines set on fire, 92.
- Cecil, *Sir William*, 49.
- Cecil Manufacturing Company, Elkton, Md., its history, 189.
- Centreville, *R.I.*, second cotton mill in Rhode Island, 178; machines copied from Slater's, 178.
- Chambers's "Book of Days," quoted, 100.
- Champlain, Samuel de, says Indians wear cotton, 41.
- Chapman, Isaac, 155.
- Chelmsford, original name of Lowell, 201.
- Cheney Brothers, their silk industry, 57.
- Chevreur, Michael Eugene, experiments in dyeing, 117.
- Chew, his "History of the Kingdom of Cotton," etc., cited, 146.
- Children, in cotton mills, 69, 78, 81, 174, 199, 200, 207-208, 244, 252.
- China, method of hand weaving, 21; source of cotton industry, 35; early home of silk industry, 45.
- Chlorine, used in bleaching, 114-115.
- City Manufacturers, New Bedford and, 239.
- Clark, Thomas M., secures water privileges for Lowell mills, 201.
- Clarke, *Mr.*, examines textile machinery, 151.
- Clay, Henry, 56.
- Clayton, *Messrs.*, establish first printing plant in Lancashire, 119.
- Clegg, Edward, 215.
- Cochineal, use of, 117.
- Colbert, Jean Baptiste, his interest in French silk industry, 49; published instructions in dyeing, 117.
- Colchester, *Conn.*, duck manufacture, 160-161.
- Colchester, *Eng.*, early woolen mill there, 68, 74.
- Colonial Assembly offers bounties for raw silk, 51.
- Colt, Christopher, his silk industries, 56, 236.
- Colt, Peter, 163; superintendent of the Paterson mills, 235.
- Columbus, Christopher, first mentions cotton in America, 39.
- Commission merchants, first ones, 175, 176.
- Compound Gear, invented by Asa Arnold, 108; English patents stolen, 108.
- Conestoga Print Works, 218.
- Confraville, perfects dyeing machinery, 118.
- Connecticut, its silk industry established, 52-55; start of the cotton industry in, 181-182.
- Connecticut, General Assembly, orders the raising of hemp and flax, 125; encourages the textile industry, 163, 165.
- Connecticut Courant*, quoted, 164, 165.
- Connecticut Journal*, quoted, 235.

- Connecticut Silk Manufacturing Company, 56.
- Constantinople, its silk industry, 47-48.
- Corduroy, manufacture of attempted in Rhode Island, 162.
- Cornbury, *Lord*, quoted, 132.
- Cornish, John, establishes the first worsted mill, 130.
- Cortez, Hernando, brings cottons from Mexico, 40-41; brings silkworms to Mexico, 51.
- Corticelli silk, 57.
- Cos, Island of, 46, 47.
- Cotton, known to the Egyptians, 17; used by Incas, 19; raised and woven by Malays, 21; crop in 1910, 34; derivation of name, 34; history of, 35-43; plant, 34, 35; Sea Island cotton, 35, 145; upland cotton, 35; by-products of, 35; cotton producing countries of the world, 35; known in England at an early date, 37; exported from England, 38; mentioned by Columbus, 39; first mention of in United States, 41; great stimulus given by American Revolution, 41; first manufactory of in America at Rowley, 42; statistics of cotton industry, 42-43; first cotton mills, 68; first use of water power, 68; whole operation of spinning first carried on in one mill, 68, 81; separated from the seed by hand, 101, 208; invention of the cotton gin, 101-105; American colonists exchange slaves for West Indian cotton, 123, 127; "Desire" and "Trial" bring cotton to New England, 123; Massachusetts General Court encourages its manufacture, 124; finer grades brought from England, 138-139; statistics of in England, 142-143; its cultivation in the Southern States, 143-144, 146, 225; origin and spread of Sea Island cotton, 145-147; exported to England, 146-147; laid by hand, 173; thread first made in America, 175; manufacture of in the South, 187-191; first cloth made entirely by power, 194; tariff on, 55, 197, 217, 232. *See* Spinning, Weaving.
- Cotton gin, invented by Eli Whitney, 101-105; increases cotton production, 146.
- Coutrai, *Belgium*, produces best prepared flax, 27.
- Coxal cloth, 71.
- Coxe, Tench, his attempt to secure English textile machines, 141-142; encourages cotton raising in the South, 143-144, 146; organizes The Pennsylvania Society for the Encouragement of Manufactures, 148.
- Crabbe, George, quoted, 91.
- Cranch, Richard, examines textile machinery, 151-152.
- Crank, *or* Scotch, loom. *See* Loom.
- Crocker, Samuel, manufactures cotton at Taunton, 180.
- Cromford, mills there first to have whole process of cotton spinning, 68, 81.
- Crommelin, Louis, 27.
- Crompton, Samuel, 73; sketch of, 83-88; his "mule," 83, 84-86; hides his machine, 85; makes his inventions public, 86; invents carding machine, 86; receives grant from Parliament, 87; his personality, 87-88; his mule first used in America, 244.
- Cromwell, Oliver, grants charter to hosiery trade, 93; prohibits export of wool from England, 128-129.
- Cumberland, *R.I.*, cotton mill there, 179.
- Cylinder card machine, used in Arkwright's mill, 68.
- Dambourney, perfects dyeing machinery, 118.
- Dana, *Dr.* Samuel L., 205.
- Dandy loom. *See* Loom.

- Danforth, Charles, invents the Cap Spinner, 108; his English patents stolen, 108-109.
- Danforth, George, invents the Taunton Speeder, 109; his speeder used in Rhode Island, 199.
- Daniel, John, constructs cotton machinery, 244.
- Daughters of Liberty, *Providence, R.I.*, adopt spinning, 138, 230.
- Davenport, James, receives first American patent on textile machinery, 108; establishes the Globe Mills, 108.
- Davol, William C., smuggles English mules to America, 228-229; installs them in Fall River, 229.
- DeFoe, Daniel, quoted, 65.
- Delaware, its silk industry, 53.
- Depouilly, develops the mercerizing process, 121.
- Derby, *Eng.*, silk mill erected, 1719, 51; hosiery mills there, 95.
- Derwent River, supplies power for cotton mills, 68, 81.
- Design, Art of, among Incas, 19; among hand weavers of China and India, 21-22.
- "Desire," *ship*, brings cotton to Salem, 123.
- Devonshire kerseys, 71.
- Dexter, Andrew, manufactures cotton in Rhode Island, 161, 230; sells machines to Moses Brown, 162, 172.
- Diaper, origin of word, 26.
- Dickens, Charles, describes Lowell mills, 207-208.
- Dickson, David, began cotton manufacture in New York, 243-244; his mill described, 244; employees and wages, 244; uses Arkwright machinery, 244; water power of his mill, 244; enterprise a failure, 244.
- Diraity, 37; made by American colonists, 126.
- Dionysius, cited, 47.
- Distaff, used in remotest times, 71; description of, 71.
- Distaff side, 73.
- Dorsey, John, makes carpets and oil cloths, 217.
- Double Speeder, invented at Waltham, 195.
- Draper, George & Sons, *Hopedale, Mass.*, instigate the invention of the Northrop loom, 110-111.
- Draper Company, *Hopedale, Mass.*, 110.
- Drebels, Cornelis van, discovers method of dyeing with cochineal, 117.
- Dressing machine, constructed at Waltham, 195; rollers made from soapstone, 195.
- Drop-box, invented by Robert Kay, 76.
- Duck, woven on eight looms in 1724, 132; bounty on granted, 133; manufactured in Boston, 160; other attempts, 160-161.
- Dufay, experiments in dyeing, 117.
- Durfee, Joseph, *Col.*, organizes the Globe Mill, 222, 223; served in the Revolution, 223; his mills described, 223; his undertaking a failure, 224; dies poor, 224.
- Dutch boy, improved by Kay, 74.
- Dyeing, evidences of in earliest times, 16-18; among Incas of Peru, 19; its history, 116-119; knowledge of brought to Europe from the Orient, 116; cultivation of dye plants, 117; discovery of cochineal dyeing, 117; discovery of aniline dyes, 118; perfection of dyeing machinery, 118; process of, 118-119.
- Dyer, *Mr.*, of Manchester, *Eng.*, patents the Taunton speeder, 109.
- Dyers' Company of London, incorporated, 117.
- Earl, Pliny, makes cards for Slater's mill, 172.
- East Greenwich, *Conn.*, stocking manufacture, 162; calico printing, 162, 231, 232.
- East India Company, controversy over calico, 38-39.

- Eau de Javel, used in bleaching, 114.
- Eclipse Speeder, invented by Gilbert Brewster, 109; used in England, 109.
- Edict of Nantes, revocation of, gives impetus to textile industries of Ireland and England, 27, 39, 49, 50.
- Edward III. restricts sheep raising, 33; restricts merchants to one line, 48; incorporates the Dyers' Company, 117.
- Edward VI., his silk stockings, 50.
- Egypt, production of cotton, 17, 35.
- Electricity, in textile mills, 69.
- Elizabeth, *Queen*, imports Flemish weavers, 23; permits free exportation of wool, 33; wears silk stockings, 50, 94; refuses patents to Wm. Lee, 93.
- Employees, early relation with employer, 65, 69; in Slater's mills, 174; care of at Waltham, 196; treatment of under the Waltham and Rhode Island systems, 199-200; care of at Lowell, 206-208; Fall River hours of work and wages, 223, 226, 227; plan for at Paterson, 234; increased production of the individual, 249-250; foreigners supplant the native-born, 250-251; lower standards of living, 251; improved condition of labor, 251.
- Employer. *See* Employees.
- England, progress of woolen industry, 23, 32-34; spinning schools, 27; a wool-producing country, 30; immigrations of Flemish weavers, 33; sheep raising restricted, 33; early references to its cotton manufacture, 37; trade in cotton, 38; silk industry in, 49-51; its textile industry in relation to agriculture, 62, 64-65; middle class formed, 70; export of wool prohibited, 128-129; export of wool from the colonies prohibited, 130; imports American cotton, 146-147; advantages for cotton industry, 193; economic and social aspects of the textile industry, 247-248.
- English Equation Box, 108.
- Essex Company, The, Lawrence, 220-221.
- Essex Gazette*, quoted, 128.
- Estes, Edward, 227.
- Europe, production of wool in 1909, 31.
- Evans, Oliver, manufactures cards, 215.
- Exeter, *N.H.*, duck manufacture, 161.
- Factory System, 59-70; English guilds forerunners of modern factory system, 59; skill, capital, and machinery causes of system, 60; Roman household embryo factory, 60; trace of in mediæval Italy, 60; John Winchcombe's factory first in England, 61; English farm first seat of textile industry, 62; its beginning appears in separation of processes, 62; artisans concentrate in hamlets, 65; relations of employer and employee, 65-68, 251; developed by era of inventions, 68; effect upon English society, 69-70.
- Fall River, leads in cotton production, 210, 222, 229; value of production, 211; growth since 1800, 222; development due to climate and water power, 222; the Globe Mill, 222-224; other mills started, 224-225, 227-229; cotton brought from the South, 225; market for and character of cotton products, 227; first print works there, 228; American Print Works, largest in America, 228; steam first used, 228; first to use self-acting mules, 228.
- Fall River Iron Works, 228.
- Fall River Manufactory, 224-225; power looms used, 226; hours

- of work and wages, 226; picking, warping, and roping, 226, 227.
- Feathers, woven by Algonquins, 22.
- Ferguson, James, his method of bleaching with lime, 114.
- Fernandina, Island of, natives use cotton, 40.
- Ferrero, Guglielmo, quoted, 60.
- Filling throstle, invented at Waltham, 195.
- Fire-proof mill, first ever built, 81.
- Fisher, Joshua, buys site for Beverly Manufactory, 155.
- Flax, known to the Egyptians, 17; one of first materials used in spinning, 24; flax plant, 24-25; preparation of, 25; Russia produces largest amount, 27; Belgian flax best prepared, 27; spun by machinery, 27; American grown for seed only, 28; production in various countries for 1909, 28; invention of machines for spinning, 98; its culture encouraged by legislative acts, 124, 125; imported by colonists, 128; raised by the colonists, 131. *See* Linen, Spinning.
- Florence, *Mass.*, silk industry established there, 56-57.
- Fly shuttle, invented by John Kay, 74-75; first used in America, 153; first used in Rhode Island, 162.
- Francis, James B., stockholder, 220.
- Frankford Woolen Mills, 218.
- Fullem, John, his stocking loom, 162, 231.
- Fuller, Thomas, his "Worthies of England" quoted, 61, 62.
- Fulling mills, erected in Massachusetts, 129-130.
- Fustians, made from both cotton and wool, 37, 38; made by American colonists, 126.
- Gazette and Country Journal*, quoted, 231.
- Gazette of the United States*, quoted, on Boston Sail Cloth Factory, 159-160.
- Genes, *M. de*, tries to improve the loom, 73.
- Georgia, cultivation of cotton in, 41; fourth in consumption of cotton, 43; progress of its silk industry, 52.
- Germantown, 130; Mennonite stocking industry, 212; early woolen industry, 212; hand stocking weavers, 212; first knitting mill in America, 212; English knitters come, 212; knitting mills, 218.
- Germantown Hosiery Mills, 218.
- Gilmore, William, introduces power loom into Rhode Island, 184, 198; his loom compared with the Waltham loom, 184, 199; sells his drawings, 184.
- Globe Mill, *Fall River*, organized by Col. Joseph Durfee, 222-223; division of stock, 223; original mill burned, 223; second mill described, 223; cleaning and weaving done outside, 223; some power used, 223; wages and hours of labor, 223; product crude, 224; enterprise a failure, 224; mill used as print works, 224; present owner, 224.
- Globe Mills, *Philadelphia*, one of the first to use water power, 108; mules installed, 216.
- Globe Yarn and Laurel Lake Mills Company, 224.
- Gobelin Dye Works, Paris, 117.
- Golding, Edmund, helps to establish the Mansfield Silk Company, 54; builds second mill at Mansfield, 55.
- Goodhue, Benjamin, 154.
- Græbe, produces vegetable dyes, 118.
- Grain, grinding of encouraged, 125; decrease in value, 125.
- Green, *Col. Job*, establishes cotton mill at Centreville, R.I., 178.
- Green, Timothy, forms partnership with Slater, 175.
- Greene, *Mrs. Nathanael*, aids Eli Whitney, 103-104.

- Greene, W. R., sets up first carpet loom at Amsterdam, 245.
- Gresham, *Sir Thomas*, 49.
- Grimshaw, *Messrs.*, their factory burned by mob, 92.
- Grinnell, Joseph, aids New Bedford cotton industry, 237-238; president of the Wamsutta Mills, 238.
- Guilds, for weavers, 33; as a forerunner of the modern factory system, 59, 65.
- Gurleyville, *Conn.*, silk mills there, 54; silk dyers at, 55.
- Haarlem, a bleaching centre, 112.
- Hall, Samuel, manufactures buckram, 132.
- Hamilton, Alexander, 149, 154, 156; mentions the Slater Mill, 174; founder of Paterson, 233.
- Hamilton Manufacturing Company established, 208.
- Hanks, Rodney and Horatio, build first American silk mill, 54.
- Hargreaves, James, 34; his unsuccessful cotton mill, 68, 73; sketch of, 77-78; helps make carding machine, 77; his spinning jenny, 77-78.
- Hartford Woolen Manufactory, first large woolen mill in America organized, 163; receives State aid, 163, 165; weaves suit for Washington, 163-164; quality of its products, 163-165; sold at auction, 165.
- Harvard College, Senior Class wear homespun, 138.
- Hatchelling, 24.
- Haverhill, *Mass.*, duck manufacture, 161.
- Hazard, Rowland, starts a fulling mill, 186; begins weaving cloth, 186; first to use water power, 186; Peace Dale Manufacturing Company, 187.
- Heard, Augustine, establishes stocking mills at Ipswich, 95.
- Heathcote, Caleb, quoted, 132.
- Heckling, 25.
- Heliogabalus, *Emperor*, wears thin silk, 47.
- Hellot, Jean, 117.
- Hemp, products of in America in 1909, 28; the native product used by the colonists, 125; Connecticut General Assembly orders the raising of, 125; imported by colonists, 128; raised by the colonists, 131; bounties on granted, 133.
- Hemptinne, *M. Jean de*, quoted, 34.
- Henry II. inaugurates cloth fair at St. Bartholomew, 33; establishes weavers' guilds, 33; legislates for advancement of woolen manufacture, 33.
- Henry IV. of Navarre, establishes mulberry-trees in France, 49; invites William Lee to bring his inventions to France, 94.
- Henry, Thomas, discovers chlorine bleaching process, 115; perfects dyeing machinery, 118.
- Herodotus, makes first mention of cotton, 36.
- Herrick, Joshua, employed at Beverly, 156.
- Hewson, John, first calico printer, 140, 215; reward offered for his head, 140.
- Higginson, Henry, 155.
- High, Thomas, his claims to Arkwright's inventions, 80, 82.
- Hill, H. A., his Memoir of Abbott Lawrence quoted, 220.
- Hinckley Knitting Mills, 218.
- Hogg, William, 218.
- Holden, R., his method of bleaching with kelp, 113.
- Hollingsworth, *Col. Henry*, manufactures woolens, 189.
- Home, Francis, his method of bleaching with sulphuric acid, 113-114; perfects dyeing machinery, 118.
- Homer, first mentions weaving, 18.
- Hopkinson, Thomas, stockholder, 219.
- Horrocks, William, invents the crank, or Scotch, loom, 106; basis

- of the Waltham loom, 106, 195; his loom introduced into Rhode Island, 184.
- Horstmann, W. H., manufactures silk, 213.
- Horstmann, William J., constructs power looms, 213.
- Hosiery. *See* Stockings.
- Houldsworth, Henry, *Jr.*, takes out patent on Asa Arnold's invention, 108; patents Samuel Batchelder's stop-motion, 109-110.
- "Huguenot," *clipper ship*, lost off Java, 21.
- Humphreys, *Col.* David, brings merinos to America, 30.
- Hurd, Duane Hamilton, his *History of Middlesex County* quoted, 194.
- India, methods of hand weaving, 21; source of cotton industry, 36, 37; learns silk industry from Chinese, 46.
- India, British, second in production of cotton, 35.
- Indians, American, weaving, 20; Algonquin feather weaving, 22.
- Indigo, artificially produced, 118.
- International Congress of Cotton Manufacturers, 34.
- Ipswich, *Mass.*, John Manning's woolen mill, 166.
- Ipswich Mills, history of, 95-96.
- Jack of Newbury. *See* Wincombe, John.
- Jackson, Daniel, makes textile machines, 161.
- Jackson, Patrick Tracy, establishes The Waltham Company, 192, 193, 194; care of employees, 196; shareholder of the Essex Company, 220.
- Jacquard, Joseph Marie Charles, sketch of his life and inventions, 96-98; his machine for making fish-nets receives gold medal, 96; his interview with Napoleon, 97; his loom, 97; his loom first used in America, 213.
- James I., *of England*, sends silkworms to Virginia, 51.
- Jarvis, William, brings merinos to America, 30.
- Jefferson, Thomas, letter to M. de Warville quoted, 144; cited, 147; inaugurated in American woolens, 189.
- Jenks, Alfred, makes cotton machinery, 216.
- Johnson, Edward, his "Wonder-working Providence" cited, 42; quoted, 126.
- Johnson, Thomas, invents the dandy loom, 106-107.
- Johnson, *Sir* William, his mill at Amsterdam, 245.
- Joint Stock Company, first one organized at Philadelphia, 215.
- Jones, Aaron, 218.
- Justinian, *Emperor*, his decree ruins silk merchants, 47; establishes silk industry in Europe, 47, 48.
- Jute, products of in America in 1909, 28.
- Kay, John, 34, 73; sketch of, 74-76; improves the reed, 74; his fly shuttle, 74-75; infringement of his patents, 75; mobbed because of his inventions, 75-76; English government refuses him aid, 76; dies in France, 76.
- Kay, John, *clock maker of Warrenton*, assists Arkwright, 78, 80; witness against Arkwright, 82.
- Kay, Robert, invents drop-box, 76.
- Kelp, used for bleaching, 113.
- Kendrew, John, inventor of machines for spinning flax, 98.
- Kentucky, cotton mills, 190.
- Knitting, early history of, 92-93; Rev. Wm. Lee invents knitting machine, 93; Queen Elizabeth refuses him patents, 93-94; Lee constructs a machine for making silk stockings, 94; Strutt's ribbed stocking frame, 94; first mill in America, 212; workmen brought under one roof, 212;

- English workmen come to Germantown, 212; mills at Philadelphia, 218.
- Labor. *See* Employees, Wages.
- Lafayette blue, 218.
- Lake Dwellings of Switzerland, ruins contain rude fabrics, 15.
- Lancaster, *Eng.*, 34; causes of concentration of textile industry in, 63-64.
- Lathrop and Eells, *Norwich, Conn.*, 181-182.
- Lawrence, Abbott, 209; stockholder of Merrimac Water Power Association, 219; Lawrence named for him, 220; founder of the Essex Company, 220, 221; memoir of, quoted, 220; buys rights of the Water Power Company, 220-221; president of the Pacific Mills, 221.
- Lawrence, Amos A., 56; operates his mills at a loss, 95, 209.
- Lawrence, Charles, offers woolens for sale, 212.
- Lawrence, John S., compares old and new methods of production, 250.
- Lawrence, Samuel, stockholder, 219, 220.
- Lawrence, William, stockholder, 220.
- Lawrence, *Mass.*, leads in production of worsted goods, 210; value of production, 211; Daniel Saunders discovers and secures the water powers, 218-219; Merrimac Water Power Association, 219, 220-221; naming the town, 219-220; the Essex Company, 220-221; great dam built, 221; town laid out, 221; the Washington Mill, 221; other mills started, 221; population and textile statistics, 222.
- Lawrence and Co., agents of Whittenton Cotton Mills, 180.
- Lawrence Company, established, 209.
- Lebermann, produces vegetable dyes, 118.
- Lec, *Rev.* William, his stocking machines, 93-94; Queen Elizabeth refuses him patents, 93-94; goes to France, 94.
- Leffingwell, Christopher, weaves stockings, 181.
- Leigh, Lewis, first successful silk dyer in United States, 55.
- L'Enfant, *Major*, superintendent of the Paterson Mills, 234-235.
- Leonard, James and Henry, employed at Beverly, 154, 155; establish Iron Works at Taunton, *Mass.*, 180.
- Levering, Wigert, early weaver, 211-212.
- Lewis, Joseph, his weaving mill at Waterbury, *Conn.*, 132.
- Lilly, Alfred, makes silk machinery, 54.
- Lincoln, Jonathan Thayer, his "The Factory" cited, 70; quoted, 249-250.
- Lindly, Joshua, makes textile machines, 161.
- Linen, known in prehistoric ages, 25-26; introduced into Europe and Asia, 26; mentioned in early writings, 26; manufacture of in France and Germany in eleventh century, 26; exported from Flanders in 1250, 26; among the Anglo-Saxons, 26-27; weaving of in Ireland, 27; weaving of a Puritan domestic industry, 27; in America only coarse forms successful, 27, 28, 131; finest produced in Scotland, Ireland, and Belgium, 27; best yarn from Holland, 28; great linen-producing countries, 28; use of cotton decreases demand for, 98; printing of at Auersburg, 119; its manufacture encouraged by colonial legislation, 124-125, 126; manufacture of at Germantown, *Pa.*, 130; fabric most used by the colonists, 131, 132; manufactured at Lynn, 132; bounties on, 133, 138; factories erected, 187; made in

- Fall River, 229; manufactured in New York, 242, 243. *See* Flax, Spinning.
- Lodge, Henry Cabot, his "Some Early Memories" cited, 157-158.
- Lombe, John, builds silk mill at Derby, 50.
- Loom, used in Bronze Age, 16; of Incas, 19, 20; Chinese legend regarding, 45; loom for piece goods built, 55; Jacquard loom first used in Philadelphia, 55, 213; owned by weavers, 66; Cartwright's power loom, 69, 89-90, 106; attempts to improve it, 73-74; Kay's improvements, 74-75; looms invented, 106; the dandy loom, 106-107; Horrocks's basis of first practical American loom, 106, 184; extended use of power loom, 107, 184; invention and characteristics of the Northrop loom, 110-111; comparison of Gilmore's and the Waltham loom, 184, 194-195; Horstmann's power loom, 213; Jenks's power loom for checks, 216; in early Fall River mills, 226. *See* Weaving.
- Lowe, H. A., discovers a method of procuring silk lustre, 121.
- Lowell, Francis Cabot, his Waltham loom compared with Gilmore's, 184; establishes The Waltham Company, 192, 194; birth and education, 193; brings home knowledge of English textile machines, 193; his power loom, 194, 195; his other inventions, 195; interview with Mr. Shepard, of Taunton, 195-196; secures a tariff on cotton, 197; urges Rhode Island mill owners to use power loom, 198; his arrangement of textile processes, 198; his system of mill organization, 198; shareholder of the Essex Company, 220.
- Lowell, John A., stockholder, 220; buys rights of the Merrimac Water Power Association, 220-221.
- Lowell, *Mass.*, mill privileges bought by Boott, 201, 202; Merrimac Manufacturing Company established, 203-204; naming of, 205; growth of, 205; other cotton mills started, 208-209; cotton statistics for 1911, 209; a textile centre, 210; value of textile products, 211.
- Lowell Company established, 209.
- Lyman, Daniel, introduces power loom into Rhode Island, 184, 198; his mill at Woonsocket, 246.
- Lyman, George W., stockholder, 220.
- Lyman, Theodore, stockholder, 220.
- Macauley, Isaac, makes oil cloths, 217.
- Mack, Alexander, stocking weaver, 212.
- McKerries, James, weaves corduroy in East Greenwich, 162, 230.
- Macquer, his experiments in dyeing, 117.
- McRae, John, makes silk fringes, *etc.*, 56.
- Madison, James, quoted, 144; inaugurated in American broadcloth, 167.
- Magellan, Ferdinand, 40.
- Malays, method of weaving cotton, 21.
- Manchester, *Eng.*, a textile centre, 34, 38, 39; climate favors textile industry, 63; weavers wear five-pound notes, 87; steam looms used there, 107.
- Manchester, *N.H.*, a textile centre, 210; value of production, 211; its history, 239-241; named in honor of Samuel Blodgett, 239-240; Benjamin Pritchard's cotton mill, 240; Amoskeag Cotton and Wool Manufactory, 240-241; Amoskeag Manufacturing Company, 241; town laid out, 241; wages, 241; growth, 241.
- Mansfield, *Conn.*, its silk industry, 53-55.

- Marble, Ezra, makes printing machine, 228.
- Marquesas Islands, natives make Tappa cloth by beating, 20.
- Maryland, its silk industry, 53; first woolen mill, 189.
- Maryland Journal*, cited, 188.
- Massachusetts, leads in consumption of cotton, 43; appoints committee to investigate textile machinery, 151-152; grants to inventors, 152-153; acquires "The State Models," 153; its textile industry just before Slater, 167; first use of Arkwright's machines, 176; textile statistics for 1812, 185.
- Massachusetts Bay Colony, General Court passes acts to help the textile industry, 124-125, 129, 136; sheep raising in, 129; wool exported in 1675, 130.
- Massachusetts Company, The, established, 209.
- Massasoit Steam Mill, 228.
- Mause, Daniel, hosier, 214.
- Mellish, John, cited on Philadelphia industries, 216.
- Mennonites, start hosiery industry at Germantown, 212.
- Mercerizing process, its history and application, 120-121.
- The *Mercury*, Salem, quoted in regard to the Beverly Cotton Manufactory, 154, 155-156.
- Merino sheep, breeds of, 30; brought to America, 30.
- Merrimac, first name for Lawrence, 219.
- Merrimac Manufacturing Company, established at Lowell, 203; shareholders, 203; canal system improved, 204, 209; mills fitted up with Waltham machinery, 204; first cloth of poor texture and color, 204, 206; builds mill machinery, 204; cylinder printing, 205-206; printers leave, 206; establish mill boarding-houses, 206; condition of employees, 206-208.
- Merrimac Water Power Association, 219, 220-221.
- Metacomet Mill, *Fall River*, 229.
- Mexico, its cotton industry, 41; its silk industry, 51.
- Mill, arrangement established by Lowell, 198; organization, 198.
- Miller, Phineas, 105.
- Miller, Robert, invents power loom, 106.
- Monteith, John, equips his mill with power looms, 106.
- Moody, Paul, first to use leather belts, 110; constructs power loom for Waltham, 194; his other inventions, 195; visits the Pawtucket Falls, 200, 202-203; employed at Lowell, 204.
- Moore, Gov., of New York, cited, 135, 138, 242.
- Moors, of *Spain*, first to raise cotton in Europe, 37.
- Mount Nebo Silk Mills, 57.
- Mulberry-tree, its seeds brought to Constantinople from China, 47, 48; mulberry-tree in France, 48-49; Chinese mulberry-tree brought to United States, 55; the "Mulberry Craze," 58.
- Mule, The, invented by Samuel Crompton, 83; self-acting first used in Fall River, 228; first used in America, 244.
- Murray, G. W., his silk mill, 236.
- Muslin brought from India, 36; East India muslin made in England, 85.
- Mussey, T. M., builds loom at Exeter, N.H., 106.
- Navajo blankets, 20.
- Naz, sheep of, 30.
- Nearchus, cited, 47.
- Nesmith, John, stockholder, 219, 220.
- New Bedford, produces finest cotton goods, 210, 239; value of production, 211; beginning of its cotton industry, 237; prejudice against the industry, 237; capital raised, 237-238; Wamsutta Mills started, 238; success of

- the enterprise, 238-239; Potomska Mill, 238; other mills built, 239; recent textile statistics, 239.
- New England, textile industry in, 122, 138-139; slave traffic with the West Indies, 123, 127; silk culture in, 138; capital develops Southern industries, 191; advantages for cotton manufacture, 193; effect of textile industries on shipping, 248-249.
- "New England's First Fruits," quoted, 125-126.
- New Hampshire, consumption of cotton, 43; first cotton mills in, 179.
- New Ipswich, first cotton mill in New Hampshire erected, 179.
- New Jersey, its silk industry, 53.
- New York, its silk industry, 53; Society for the Promotion of Arts established, 138, 242; linen manufacture in, 138; Society for the Encouragement of American Manufactures, 170; greatest centre for cutting up trade, 210, 245; value of production, 211, 245; Manufacturing Society, 242-243; Dickson's Cotton Factory, 243-244; not suited for textile industry, 242, 244.
- New York and Northampton Silk Company, The, 56.
- New York Manufacturing Company, employs Samuel Slater, 169; history of, 170, 242-243; its object, 242; character of the product, 243; factory described by Slater, 243; enterprise a failure, 243.
- New Zealand, production of wool in 1909, 31.
- Newcomen, Thomas, his steam-engine perfected by James Watt, 99-100.
- Newell, Robert, calico printer, 232.
- News Letter*, quoted, 137.
- Nickerson, *Capt.* Sylvanus, describes Malay method of weaving cotton, 21.
- Nonatuck Silk Company, 56.
- North Carolina, consumption of cotton, 43.
- North Saugus, linen factory built, 187.
- Northrop, James H., invents a loom, 110-111.
- Norwich, *Conn.*, early stocking weaving there, 181; Lathrop and Eells cotton manufactory, 181-182.
- Oglethorpe, *Gov.* James Edward, gives silk to Queen Caroline, 52.
- Oil cloths, made in Philadelphia, 217.
- Oldham, brings wild hemp from Connecticut, 125.
- Oneida County, *N.Y.*, first cotton mill erected, 179.
- Opdengrafe, Abraham, receives premium for linen, 211.
- Orr, *Col.* Hugh, early textile machinery made at his works, 151, 153; makes first cannon in America, 151; first in America to use the fly shuttle, 153.
- Ottolengi, *Signor*, establishes a silk filature in Georgia, 52.
- Oxford Carpet Mills, The, 218.
- Pacific Mills, *Lawrence*, 221.
- Panic, first one in New England, 125.
- Parkinson, Adam, perfects printing method, 120.
- Paterson, *N.J.*, its silk industry, 55, 210, 236; value of production, 211; founded by the Society for the Establishment of Useful Manufactures, 233-234; naming of, 234; water power secured, 234; plans for mills and workmen's houses, 234; factory equipped and opened, 235; enterprise a failure, 235; mill used for other purposes, 235-236; water rights valuable, 236; first silk mill, 236; character of silk products, 236.
- Paul, Lewis, 73; his inventions, 77.

- Pawtucket, Slater's mill, 171-175; industries affected by the War of 1812, 198; a textile centre, 210; value of production, 211.
- Peace Dale Manufacturing Company, its history, 186-187.
- Pearson, John, erects first cloth mill in United States, 126.
- Peck, Lewis, manufactures cotton in Rhode Island, 161; sells machine to Moses Brown, 162, 172.
- Peel, Sir Robert, offers partnership to Crompton, 86.
- Penelope, goddess of weaving, 18.
- Penn, John, quoted on Philadelphia industries, 214, 216.
- Pennsylvania, its silk industry, 53; Society for the Encouragement of Manufactures, history of, 148-150; may have established first American cotton mill, 149; its textile industry just before Slater, 167; encourages home industries, 215.
- Pepys, Samuel, quoted, 39.
- Perrot, his process of block printing, 120.
- Perry, Nathaniel, his linen mill at North Saugus, 187.
- Philadelphia, its silk manufacture, 55; societies for the promotion of manufactures established, 139-140, 148-150, 215; leading textile city in United States, 210; greatest producer of hosiery and knit goods, 210; annual production, 211; stocking industry, 212, 214; woolen industry, 212, 213-215; first knitting mill in America, 212; silk industry, 213; filatures established, 213; English silk throwsters come, 213; Jacquard loom first used, 213; sheep killing prohibited, 214; the "Hand in Hand" Stocking Manufactory, 214; home manufactures encouraged, 214, 216; first joint stock company organized, 215; a centre for textile machinery, 215-216; its carpet industry, 216-217; textile statistics, 217-218; merchants ask for textile tariff, 217.
- Picking machine, Blair's, first used, 226.
- Pierpont, John, erects mills in Roxbury, 129.
- Pioneer Hosiery Mills, *Amsterdam*, 246.
- Plate speeder, an American invention, 109.
- Pliny, quoted, 36; cited, 47, 112; cited, on art of dyeing, 116.
- Pocasset Manufacturing Company, 227.
- Polo, Marco, describes cotton, 37.
- Porthouse, Thomas, invents machines for spinning flax, 98.
- Potomska Mill, *New Bedford*, 238.
- Potter, Nathaniel, receives bounty for linen manufacture, 132, 133.
- Prince, John D., 205.
- Printing, its history from the earliest times, 119-120; first print works in England, 119; block printing, 119-120, 232; Perrotine, plate, and cylinder printing, 120; cylinder printing at Lowell, 205-206.
- Pritchard, Benjamin, starts mill at Goffstown, N.H., 240; it becomes the Amoskeag Company, 240.
- Proprietors of the Locks and Canals on the Merrimac River, 127; its stock sold to the Merrimac Company, 202, 203.
- Providence, *R.I.*, beginning of cotton industry, 161-162, 230; uses Beverly models, 161, 230; attempt to make corduroy, 162, 231; arrival of Samuel Slater, 171, 231; Almy, Brown & Slater, 171-175; first steam mill, 184; great textile centre, 210; value of production, 211; cotton industry in 1789, 231; early thread and stocking industries, 231; calico printing, 231-232; textile statistics, 232.
- Prussian blue, 218.

- Rehoboth, *Mass.*, the Slater mill, 175-176; second mill built, 178.
- Revolution, American, effect on American textile industry, 53, 140-141, 213, 214.
- Rhoades, Alonzo E., invents a shuttle-changing loom, 110.
- Rhode Island, consumption of cotton, 43; beginning of the cotton industry, 161-162; use Beverly models, 161; attempt to make corduroy, 162; manufacture of stockings, 162; calico printing, 162; its textile industry just before Slater, 167; Samuel Slater's mills, 171-175; second cotton mill in, 178; introduction of power loom, 184, 199; textile statistics for 1812, 185; beginning of power woolen mills, 186-187. *See also* Providence, Woonsocket.
- Rhode Island System *versus* the Waltham System, 198-200.
- Ribbons, manufactory at Baltimore, 56.
- Richards, F. G., 215.
- Richards, Mark, 216.
- Richmond, Charles, manufactures cotton at Taunton, *Mass.*, 180.
- Richmond, first print works in England there, 119.
- Ridgeway, *Mr.*, improves the bleaching processes, 115.
- Ring spinning, developed, 109; ring spinner invented by John Sharp, 110.
- Rixford, Nathan, builds silk machines, 54.
- Robbins, Charles, builds cotton mill, 179.
- Roberts, Lewis, his "Treasures of Traffic," cited 38.
- Robeson, Andrew, starts first print works in Fall River, 228; mill develops into the American Print Works, 228.
- Robinson, *Mrs.* Harriet Hanson, her "Loom and Spindle" quoted, 206.
- Rock Day, 73.
- Rogers, Ezekiel, settles at Rowley, *Mass.*, 126.
- Rogers, Richard, his duck weaving mill, 132.
- Rope-making machine, invented by Cartwright, 91.
- Rowley, *Mass.*, site of first cloth mill in the United States, 42, 126-127.
- Royal Society of London, publish "An Apparatus, *etc.*, to assist Dyers," 117.
- Rucellai, of Florence, make purple dye, 116.
- Runge, Ferdinand Friedrich, discovers aniline dyes, 118.
- "Runs of stone," 127.
- Russell, William, 181.
- Russia, produces largest amount of flax, 27; its production of cotton, 35.
- Ryle, John, "father of American silk industry," builds first loom for piece goods, 55; his silk mills at Paterson, 236.
- St. Aubon, Guipape de, brings white mulberry-tree to France, 48.
- St. Distaff's Day, 73.
- Salem, *Mass.*, duck manufacture, 161.
- Sargent, Ignatius, director of the Essex Company, 221.
- Saunders, Daniel, discovers and secures water power of the Merrimac, 218-219; forms the Merrimac Water Power Association, 219; names Merrimac, 219; forms the Essex Company, 220.
- Saunders, Daniel, *Jr.*, stockholder, 219.
- Savannah, reeling establishment founded there, 52.
- Schaub, Tissot & Dubosque, begin calico printing in Providence, 231-232.
- Scheele, C. W., discovers use of chlorine for bleaching, 114.
- Scholfield, Arthur, comes from England, 165-166; employed

- by Newburyport Woolen Manufactory, 166; his woolen mill at Pittsfield, 167.
- Scholfield, John, comes from England, 165-166; employed by the Newburyport Woolen Manufactory, 166; builds first woolen mill in Connecticut, 166; his mill at Stonington, Conn., 167; weaves broadcloth for the President, 167.
- Scotland, linen weaving in, 27; bleaching, 113.
- Scrutching, 24.
- Seaconnet Mill, *Fall River*, adopts the Northrop loom, 110.
- Semiramis, *Queen*, 18, 36.
- Shakespeare, William, refers to the bleaching process, 112.
- Sharp, John, invents the ring spinner, 110.
- Sheep, coat changed from hair to wool by breeding, 29; breeds of, 29-31; first mention of in England, 30; merinos brought to America, 30; Lincoln rams, 31; number raised in 1910, 31-32; domestic in Britain before the Roman Conquest, 32; raising restricted in England, 33; raising of among American colonists, 123, 126, 129; their exportation from England prohibited, 129; killing restricted in Philadelphia, 214. *See also* Wool.
- Shepard, Benjamin, starts cotton mill at Wrentham, Mass., 177-178.
- Shepard, Silas, of *Taunton*, makes winding machines, 196.
- Shepard, *Mrs.*, exchanges goods for a chaise, 177-178.
- Si-ling-chi, the "Goddess of Silk-Worms," 45-46; said to have invented the loom, 46.
- Silk, derivation of name, 43; thought to grow upon trees, 43; secreted by spiders and silkworms, 43-44; statistics of production, 44-45; history of, 45-58; Chinese legend of origin of silk making, 45; from China the art spreads to Japan and Europe, 46, 47-48; used by higher classes in Rome, 47; used in England, 48; importation of prohibited in England, 48, 50; trade in France, 48; silk industry in England, 49-51; industry in America, 51-58, 138; England removes duties on American silk, 51, 52; the Revolution suspends the silk industry, 53; American silk inferior, 53; first mill in America at Mansfield, Conn., 54; mills at Paterson, N.J., 55, 210, 236; first successful dyeing in United States, 55; English weavers come to United States, 55; tariff of 1861, 55; "Mulberry Craze" checks industry, 58; raw silk used in United States imported, 58; industry in Philadelphia, 213. *See also* Ribbons.
- Silk machinery, that first used in England crude, 50; copied from Italian, 50.
- Silk throwing mill, first in England, 50.
- Silkworm, described, 44, 46; eggs brought from China, 48.
- Skinner, William, his silk industry, 57.
- Slater, John, brings knowledge of English improvements in textile machines, 183; helps establish mill at Slatersville, 183.
- Slater, Samuel, early history, 168; emigrates secretly to America, 169; finds employment in New York, 169; corresponds with Moses Brown, 169-170, 243; goes to Providence, 171; partnership with Almy and Brown, 171; constructs machines on Arkwright's models, 172; makes Earl's cards work, 172; starts mill at Pawtucket, 173; uses cotton warp, 173; reduces price of cloth, 174; payment and discipline of employees, 174; establishes first Sunday-school,

- 174; markets for his yarns, 174-175, 176; rapidity of production, 175; Samuel Slater and Co. build mill at Rehoboth, Mass., 175; begins weaving cotton, 176; his influence on cotton industry, 179, 185, 222, 233; erects first steam mill, 184; buys the Amoskeag Mill, 240.
- Slatersville, *R.I.*, cotton mill, 183.
- Slaves exchanged for West Indian cotton and rum, 123, 127.
- Soapstone, used for rollers, 195.
- Social Manufacturing Company, Woonsocket, 246.
- Society for the Establishment of Useful Manufactures, founds Paterson, 233-234, 236.
- Somers, Thomas, petitions the Massachusetts legislature for aid, 152; constructs textile machines, 153; "The State Models," 153; employed at Beverly, 154, 156.
- South Africa, production of wool in 1909, 31.
- South Carolina, cultivation of cotton in, 41, 146; consumption of cotton, 43; silk industry, 52; first cotton mill, 188.
- Southern states, produce largest amount of cotton in the world, 35; beginning and growth of its cotton crop, 41, 144-147, 190; Sea Island cotton, 145-147; development of cotton manufacture in, 187-191; supply Fall River cotton mills, 225.
- Southwark, early bleachery there, 112.
- Spear side, 73.
- Spider, silk-producing, 43-44.
- Spindle, found in ruins of Swiss Lake Dwellers, 15; used in Bronze Age, 16; of the Incas, 19; description of, 71.
- Spinning, evidences of in pre-historic times, 13-16; traditions as to origin, 17; progress of art from East to West, 22; machinery first used in Ireland, 27; schools for in England, 27; Britons taught by Romans, 32; Angles and Saxons had knowledge of, 32; a by-product of farm life, 62; separated from agriculture, 64; spinners becoming a separate class, 66; method of in early times, 71-72; construction of spinning wheel, 72, 73; whole operation under one roof, 68, 81; Crompton's "mule" makes fine spinning possible, 85; statistics of, for 1812, 87; introduction of ring spinning, 109; in American colonies, 123; classes formed, 129, 138; Boston spinning craze, 135-137; bounties offered, 138. *See* Loom, Textile industry, Weaving.
- Spinning frame, invented by Arkwright, 80-82; constructed at Providence, 161; constructed by Slater, 172.
- Spinning jenny, invented by James Hargreaves, 77-78; Christopher Tully's, 140.
- Spinning wheel, history of, 72; value of in colonial times, 123.
- Spinster, 73.
- Sprague, William Peter, makes carpets, 216-217.
- Springfield, *Mass.*, duck manufacture, 161.
- Star Hosiery Mills, *Amsterdam*, 245.
- Stark Mill, *Manchester, N.H.*, 241.
- "State Models, The," exhibited in Massachusetts, 153.
- Steam-engine, 60; first used for cotton manufacturing, 69; Cartwright's improvements, 91; Watt's improvements, 99-100; first used in Fall River, 228.
- Stevens, Nathaniel, stockholder, 219.
- Stockings, 49-50, 92; Queen Elizabeth's silk stockings, 50, 94; invention of stocking machinery, 93-94; Strutt's mills at Derby, 95; the Ipswich Mills, 95-96; industry at Germantown, Pa., 130, 212; woven at East

- Greenwich, 162; industry in Connecticut, 181; hand stocking weaving, 212; made in Philadelphia, 214; industry at Amsterdam, 245, 246.
- Stockport, *Eng.*, steam looms used there, 107.
- Stop-motion, invented by Samuel Batchelder, 109.
- Storrow, Charles S., engineer of the Essex Company, 220, 221.
- Stratford, *Mass.*, duck manufacture, 161.
- Straw, Ezekiel, engineer of the Amoskeag Mills, 240-241.
- Strutt, Jedediah, 81; invents ribbed stocking frame, 94; his stocking mills at Derby, 95; Slater his apprentice, 168.
- Sturgis, William, shareholder, 220; director of Essex Company, 221.
- Suffolk Company, established, 209.
- Suffolk County Court Records, quoted, 123.
- Sulphuric acid, used in bleaching, 113-114.
- Surnames, English, derived from the textile industry, 63.
- Swivel's loom, 74.
- Taft, Royal C., cited, 165.
- Tappa cloth, made from cloth tree by beating, 20.
- Tariff, of 1816, 197, 232; of 1861, 55; ad valorem duty, 217.
- Taunton, *Mass.*, the Whittenton Cotton Mills, 180-181.
- Taunton Speeder, invented by George Danforth, 109; used in England, 109.
- Teake, Richard, letter quoted, 146; first to raise cotton extensively in the South, 146.
- Tenant, Charles, his bleaching process, 115.
- Textile cities, in order of production, 210.
- Textile industry, in America, its history, 122; first settlers bring knowledge of from England, 122; climatic conditions and distance from England foster it, 122; colonial legislation aids it, 124-125, 128, 129, 132-133; first cloth mill at Rowley, *Mass.*, 126; textile mills began in stone water mills, 123, 127; English efforts to hamper it, 128-129, 130; at the beginning of the Revolution, 137-139; greatly developed during the Revolution, 140; just before Slater, 167; statistics of, about 1812, 185; the great textile centres, 210-211; nature of the products, 211; amount and value of the output in 1909, 211; its economic and social aspects, 248; statistics of growth, 249. *See* Cotton, Silk, Spinning, Weaving, Wool.
- Textile machinery, era of invention, 71-121; England prohibits its exportation, 139; Christopher Tully's spinning jenny, 140; American efforts to secure English machines, 141-142; made in Philadelphia, 215-216.
- Textiles, in prehistoric times, 13-16; found in barrows of Early Britons, 16; among Cliff Dwellers of America, 16; among ancient Peruvians, 19; English products inferior, 33. *See* Cotton, Silk, Spinning, Weaving, Wool.
- Thorndike, Israel, 155.
- Thread, cotton, first made in America, 175.
- Throckmorton, Sir John, has a suit made on a wager, 100-101.
- Tiberius, *Emperor*, prohibits men from wearing silk, 47.
- Tiverton Print Works, 224.
- Toad, *Mr.*, invents a loom, 106.
- Toby, *Mr.*, of Lynn, gets bounty on cloth, 128.
- Trade-mark, first one, used at Beverly, 155.
- Tremont Company, established, 209.
- "Trial," *ship*, brings cotton to Boston, 123.
- Troy Cotton and Woolen Manufactory, 224-225; power looms installed, 226.

- Troy Manufactory Company, 224-225.
- Tyler, Jonathan, stockholder, 219, 220.
- Union Cotton Factory, *Fall River*, 227.
- United Company of Philadelphia, *etc.*, history of, 139-140, 148; first joint stock company, 215.
- United Kingdom, production of wool in 1909, 31.
- United States. *See* Textile industry in America.
- Uruguay, production of wool in 1909, 31.
- Vallentine, Edward, first successful silk dyer in United States, 55.
- Vandausen, Herman, first calico printer in Rhode Island, 162, 231.
- Vaucanson, Jacques de, his automaton furnish ideas to Jacquard, 97.
- Virgil, cited, 47.
- Virginia, cultivation of cotton, 41; attempt to establish silk industry there, 51, 53.
- Wadsworth, Jeremiah, stockholder of Hartford Woolen Manufactory, 163; buys the business, 165.
- Wages in Slater's mill, 174; paid in money at Waltham, 196, 200; paid in merchandise, 199-200; in Col. Durfee's mill, 223; in other Fall River mills, 226; of the Amoskeag Company, 241; in New York, 244.
- Walcott, Benjamin S., builds cotton mill, 179.
- Walcott, Benjamin S., *Jr.*, erects cotton mill in New York, 179.
- Waltham Company, establishes the first cotton mill run completely by power, 192; incorporated, 194; capital, 194; Lowell's power loom, 194-195; description of the mill, 194; first cloth made, 194; textile machines invented by Moody and Lowell, 195; enterprise extended, 196; regular wages paid employees, 196, 200; mill boarding-houses, 196, 200; character of employees, 196; sale of goods, 197; the Waltham system compared with the Rhode Island system, 198-200; children not employed, 200; success of, 200.
- Waltham System *versus* the Rhode Island System, 198-200.
- Wamsutta Mills, *New Bedford*, 238-239.
- War of 1812, its effect upon the textile industry, 197, 200, 217.
- Ward, Benjamin C., and Co., selling agents for Waltham Mills, 197.
- Waring, Elijah, commission merchant, 175.
- Warp, supplied by employer, 67; warping mills established, 67; improved by Arkwright's inventions, 79, 82; of cotton, used at Pawtucket, 173; warper invented at Waltham, 195; cotton replaces linen, 227.
- Washington, George, brings spinners, weavers, and sheep from England, 30; visits the Beverly Cotton Manufactory, 157-158; describes the Boston Sail Cloth Factory, 160; inaugurated in suit of Hartford manufacture, 163; letter quoted, 163-164; Washington Mill, *Lawrence*, 221.
- Water frame, used in Arkwright's mill, 68; wide use of in England, 143. *See* Spinning frame.
- Water power, used for cotton mills, 68; of New York mill, 244.
- Waterman, Rufus and Elisha, build cotton mill, 179.
- Watt, James, his steam-engine first used in cotton manufacturing, 69; his improvements upon Newcomen's steam-engine, 99-100; uses chlorine process for bleaching, 114.

- Weaving, in prehistoric times, 14-16; traditions of its origin, 17, 18; by Malays, 21; by hand weavers of India and China, 21; machinery first used in Ireland, 27; immigrations of Flemish weavers to England, 33; weavers' guilds established, 33; a by-product of English farm life, 62; separated from agriculture, 64-65; women replaced by men, 67; legal terms, 73; Kay's improvements change method of, 75; among American colonists, 123, 129, 133. *See* Cotton, Loom, Textile industry, Wool.
- Weft, made by weavers, 67.
- Wells, Obadiah, his linen manufactory, 138.
- West Houghton, steam looms used there, 107.
- West Indies, exchange cotton and rum for slaves, 123, 127.
- Wetherill, Samuel, *Jr.*, aids American manufactures, 139-140; organizes The Pennsylvania Society for the Encouragement of Manufactures, 148; contracts to supply the army with woollens, 215.
- "Whiting time," 112.
- Whitman, David, 237.
- Whitmarsh, Samuel, builds silk mill at Florence, Mass., 56.
- Whitney, Eli, sketch of his life and inventions, 101-105; his cotton gin, 101-105; his invention stolen, 104; obtains a grant for his invention, 105; manufactures firearms, 105; marriage and death, 105.
- "Whitsters," 112.
- Whittemore, Amos, 215, 216.
- Whittenton Cotton Mills, *Taunton, Mass.*, history of, 180-181.
- Wilkinson, David, builds power looms, 184.
- Wilkinson, Hannah, makes first cotton thread in America, 175.
- Wilkinson, Oziel, constructs Slater's machines, 172; forms partnership with Slater, 175.
- Wilkinson, William, forms partnership with Slater, 175.
- William the Conqueror, 33, 39.
- Willowing, 67.
- Wilmington, *Del.*, society organized for the encouragement of American industries, 189-190; early cotton mill, 190.
- Winchcombe, John, his factory the first in England, 61.
- Winding machines, made by Silas Shepard, of Taunton, 196.
- Winthrop, John, *Governor of Massachusetts*, orders establishment of runs of stone, 125; his sons promote trade with the West Indies, 127.
- Winthrop, John, *Jr.*, quoted, 125.
- Wolcott, Oliver, stockholder, 163.
- Women in industry. *See* Employees, Wages.
- Wood Worsted Mill, *Lawrence*, largest in the world, 221.
- Wool, used in Stone Age, 14; fabrics of found in ruins of Swiss Lake Dwellers, 15; woolen cloth in barrows of early Britons, 16, 32; probably first material used for weaving, 16, 29; known to the Egyptians, 17; used by Incas, 19; manufacture highly developed in Flanders, 22; manufacture of in England, 23, 32-34; of animals other than sheep, 29; grades of, 30-31; production of in sheep raising countries in 1909, 31; manufactures of in America in 1909, 32; exportation of in England, 33, 34; sources of for New England colonists, 123; first worsted mill established by John Cornish, 130; production of in New England, 127-128, 133; nature of New England products, 135; finer grades brought from England, 138-139; manufacture of in Philadelphia, 212. *See* Sheep.
- Wool-combing machine, invented by Cartwright, 91.

- Woonsocket, *R.I.*, a textile centre, 210; value of production, 211; fine water power, 246; Social Manufacturing Company formed for making cotton, 246; its mill and machinery, 246-247; other mills started, 247; character and value of output, 247.
- Worcester, *Mass.*, early attempt at cotton manufacture, 151, 160.
- Working classes. *See* Employees.
- Worsted, first mill built by John Cornish, 130.
- Worthen, Ezra, 200.
- Wrentham, *Mass.*, Benjamin Shepard's cotton mill, 177-178.
- Wyatt, John, 73; his inventions, 77.
- Yarn, how made in Peru, 19; best comes from Holland, 28; made from cotton, 82. *See* Spinning.

ERRATA

- Page 16. For Bretons read Britons.
Page 73. For James Crompton read Samuel Crompton.
Page 162. For McKerris read McKerries.
Page 231. For Henry Vandausen read Herman Vandausen.

