

Reference

NBS
Publi-
cations

A11101 885801

NAT'L INST OF STANDARDS & TECH R.I.C.



A11101885801

American National St/American National S
QC1 .U51 NO.136 V1981 C.1 NBS-PUB-R 1981



NBS HANDBOOK 136

U.S. DEPARTMENT OF COMMERCE / National Bureau of Standards

American National Standard N432;
Radiological Safety for the
Design and Construction
of Apparatus for
Gamma Radiography



AMERICAN NATIONAL STANDARD N432 1980

QC

1

.U51

#136

1981

NATIONAL BUREAU OF STANDARDS¹

The National Bureau of Standards¹ was established by an act of Congress on March 3, 1901. The Bureau's overall goal is to strengthen and advance the Nation's science and technology and facilitate their effective application for public benefit. To this end, the Bureau conducts research and provides: (1) a basis for the Nation's physical measurement system, (2) scientific and technological services for industry and government, (3) a technical basis for equity in trade, and (4) technical services to promote public safety. The Bureau's technical work is performed by the National Measurement Laboratory, the National Engineering Laboratory, and the Institute for Computer Sciences and Technology.

THE NATIONAL MEASUREMENT LABORATORY provides the national system of physical and chemical and materials measurement; coordinates the system with measurement systems of other nations and furnishes essential services leading to accurate and uniform physical and chemical measurement throughout the Nation's scientific community, industry, and commerce; conducts materials research leading to improved methods of measurement, standards, and data on the properties of materials needed by industry, commerce, educational institutions, and Government; provides advisory and research services to other Government agencies; develops, produces, and distributes Standard Reference Materials; and provides calibration services. The Laboratory consists of the following centers:

Absolute Physical Quantities² — Radiation Research — Thermodynamics and Molecular Science — Analytical Chemistry — Materials Science.

THE NATIONAL ENGINEERING LABORATORY provides technology and technical services to the public and private sectors to address national needs and to solve national problems; conducts research in engineering and applied science in support of these efforts; builds and maintains competence in the necessary disciplines required to carry out this research and technical service; develops engineering data and measurement capabilities; provides engineering measurement traceability services; develops test methods and proposes engineering standards and code changes; develops and proposes new engineering practices; and develops and improves mechanisms to transfer results of its research to the ultimate user. The Laboratory consists of the following centers:

Applied Mathematics — Electronics and Electrical Engineering² — Mechanical Engineering and Process Technology² — Building Technology — Fire Research — Consumer Product Technology — Field Methods.

THE INSTITUTE FOR COMPUTER SCIENCES AND TECHNOLOGY conducts research and provides scientific and technical services to aid Federal agencies in the selection, acquisition, application, and use of computer technology to improve effectiveness and economy in Government operations in accordance with Public Law 89-306 (40 U.S.C. 759), relevant Executive Orders, and other directives; carries out this mission by managing the Federal Information Processing Standards Program, developing Federal ADP standards guidelines, and managing Federal participation in ADP voluntary standardization activities; provides scientific and technological advisory services and assistance to Federal agencies; and provides the technical foundation for computer-related policies of the Federal Government. The Institute consists of the following centers:

Programming Science and Technology — Computer Systems Engineering.

¹Headquarters and Laboratories at Gaithersburg, MD, unless otherwise noted; mailing address Washington, DC 20234.

²Some divisions within the center are located at Boulder, CO 80303.

JUN 15 1981

American National Standard N432;

Radiological Safety for the Design and Construction of Apparatus for Gamma Radiography

American National Standards Institute
Subcommittee N43-3.5

Under the sponsorship of the
National Bureau of Standards
Washington, DC 20234

Approved August 15, 1980
American National Standards Institute
New York, NY 10018

ANSI N432-1980



U.S. DEPARTMENT OF COMMERCE, Philip M. Klutznick, Secretary

Jordan J. Baruch, Assistant Secretary for Productivity, Technology and Innovation

NATIONAL BUREAU OF STANDARDS, Ernest Ambler, Director

Issued January 1981

National Bureau of Standards Handbook 136

Nat. Bur. Stand. (U.S.), Handb. 136, 19 pages (Jan. 1981)

CODEN: NBSAP

U.S. GOVERNMENT PRINTING OFFICE
WASHINGTON: 1981

For sale by the Superintendent of Documents, U.S. Government Printing Office, Washington, D.C. 20402

Price \$1.50

(Add 25 percent for other than U.S. mailing)

American National Standard

An American National Standard implies a consensus of those substantially concerned with its scope and provisions. An American National Standard is intended as a guide to aid the manufacturer, the consumer, and the general public. The existence of an American National Standard does not in any respect preclude anyone, whether he has approved the standard or not, from manufacturing, marketing, purchasing, or using products, processes or procedures not conforming to the standard. American National Standards are subject to periodic review and users are cautioned to obtain the latest editions. Producers of goods made in conformity with an American National Standard are encouraged to state in their own advertising, promotion material, or on tags or labels, that the goods are produced in conformity with particular American National Standards.

CAUTION NOTICE. This American National Standard may be revised or withdrawn at any time. The procedures of the American National Standards Institute require that action be taken to reaffirm, revise, or withdraw this standard no later than 5 years from the date of publication. Purchasers of American National Standards may receive current information on all standards by calling or writing the American National Standards Institute, 1430 Broadway, New York, NY 10018.

Foreword

(This foreword is not a part of American National Standard N432, Radiological Safety for the Design and Construction of Apparatus for Gamma Radiography.)

The subject of gamma radiography was discussed extensively during a meeting of Standards Committee N43 in November 1974. It was generally agreed that there was a need to initiate two projects in this area. One would be concerned with design of equipment and the other would consider the operation of equipment, including training and administrative responsibility.

Work on the equipment standard began in 1975, with a draft ISO specification on apparatus for gamma radiography serving as a reference document. By December 1976, the subcommittee had produced a draft standard for comment and discussion. The work was accelerated when the Nuclear Regulatory Commission published an advance notice of proposed rulemaking in March 1978 relating to safety design requirements for radiographic exposure devices. A final draft standard was mailed to members of the subcommittee in September 1978, along with a ballot that resulted in a consensus of approval.

Suggestions for improvement of this standard will be welcome. They should be sent to the American National Standards Institute, 1430 Broadway, New York, NY 10018.

American National Standards Committee N43, on Equipment for Non-Medical Radiation Applications, which processed and approved this standard, had the following personnel at the time of approval:

Elmer H. Eisenhower, *Chairman*
(National Bureau of Standards)

<i>Organization Represented</i>	<i>Name of Representative</i>
American Chemical Society	Edward E. Beauchamp
American Conference of Governmental Industrial Hygienists	LTC Gordon M. Lodde
American Crystallographic Association	Stanley Block
American Federation of Labor and Congress of Industrial Organizations	Jack R. Suarez
American Insurance Association	John G. Pack
American Iron and Steel Institute	Anthony LaMastra
	Wayne T. Brooks (Alt.)
American Mutual Insurance Alliance	Leon D. Horowitz
	Thomas F. Bresnahan (Alt.)
American Nuclear Society	James E. McLaughlin
	W. E. Kreger (Alt.)
American Public Health Association, Inc.	Francis J. Bradley
	Jesse Lieberman (Alt.)
American Society of Mechanical Engineers	Herbert R. Isenburger
American Society for Nondestructive Testing, Inc.	John P. Battema
	Warren M. Holm (Alt.)
American Society for Testing and Materials	Marvin M. Turkanis
	Jack Bystrom (Alt.)
American Welding Society	Edward L. Criscuolo
Conference of Radiation Control Program Directors	Leonard Solon
	Richard Lane (Alt.)
Health Physics Society	John H. Weiler
	Robert M. Ryan (Alt.)
Institute of Electrical and Electronics Engineers, Inc.	Thomas R. Kohler
Instrument Society of America	H. L. Cook, Jr.
International Brotherhood of Electrical Workers	Paul R. Shoop
National Bureau of Standards	Elmer H. Eisenhower
National Council on Radiation Protection and Measurements	Carl B. Braestrup
National Electrical Manufacturers Association	M. L. Jackson
Underwriters' Laboratories, Inc.	Larry S. Homa
U.S. Nuclear Regulatory Commission	Donovan A. Smith
U.S. Department of the Air Force, Office of the Surgeon General	Captain David N. Wood
	LTC Owen H. Kittilstad (Alt.)
U.S. Department of the Army, Office of the Surgeon General	Col. Robert T. Wangemann
	Col. Taras Nowosiwsky (Alt.)
U.S. Department of the Navy	Gene W. Hendrix
U.S. Department of Defense	Satrak Der Boghosian
	Charles P. Merhib (Alt.)
U.S. Department of Health and Human Services, Public Health Service	Walter E. Gundaker
Individual Member	Edwin A. Miller (Alt.)
	John R. Dukes

Subcommittee N43-3.5, which had responsibility for developing this standard, consisted of the following personnel:

Robert J. Prest, *Chairman*
(Tech/Ops)

Stephen Boyko
K. Ray Fujimoto
Tom M. Gaines
Joseph E. Gorrell
Anthony LaMastra
John McCormack
John J. Munro III
Harry Richardson
Gary M. Rusinovich
Michael Santoro
Donovan Smith
John H. Weiler

Automation Industries, Inc.
Health and Welfare, Canada
Industrial Nuclear Co.
Texas Dept. of Health Resources
Bethlehem Steel Corp.
Chicago Bridge & Iron Co.
Technical Operations, Inc.
Nuclear Systems, Inc.
Bethlehem Steel Corp.
Automation Industries, Inc.
U.S. Nuclear Regulatory Commission
Offshore Power Systems

Contents

	Page
Foreword.....	iv
Abstract	viii
1. Scope.....	1
2. Definitions	1
3. Classification.....	1
3.1 Handling Characteristics of Exposure Devices.....	1
3.2 Operational Characteristics of Exposure Devices	2
3.3 Operational Characteristics of Controls.....	2
4. Marking and Identification	2
5. Design and Construction of Exposure Devices.....	2
5.1 General Requirements	2
5.2 Additional Requirement for Class P Exposure Devices	3
5.3 Additional Requirements for Class M Exposure Devices.....	3
6. Design and Construction of Controls.....	3
6.1 General Requirements	3
6.2 Additional Requirement for Local Controls.....	4
7. Design and Construction of Source Assemblies.....	4
8. Tests.....	4
8.1 Shielding Efficiency Test	4
8.2 Horizontal Shock Test	5
8.3 Vertical Shock Tests.....	5
8.4 Accidental Drop Tests	6
8.5 Kinking Test	6
8.6 Crushing Test.....	7
8.7 Tensile Test for Controls.....	8
8.8 Tensile Test for Source Assemblies.....	8
8.9 Endurance Test	8
Appendix A. Product Assurance.....	9

Abstract

This standard applies to the design and construction of apparatus used for industrial gamma radiography which employs radioactive material as the energy source. It establishes the criteria to be used in the proper design and construction of the various components to ensure a high degree of radiation safety at all times. This includes the classification and labeling criteria for the exposure device; and factors which should be considered in the design and construction of exposure devices, controls, and source assemblies. The testing procedures and equipment for the various classifications of the exposure devices and source assemblies are detailed.

Key words: Classification criteria; gamma radiography; national standard; performance tests; radiation source; safety standard.

American National Standard

Radiological Safety for the Design and Construction of Apparatus for Gamma Radiography

1. Scope

This standard provides guidance for persons responsible for the design and construction of apparatus for industrial gamma radiography using radioactive materials as the energy source. It covers criteria for the design of new devices and for qualifying prototypes to performance standards.

2. Definitions

The definitions and terms contained in this standard, or in other American National Standards referred to in this document, are not intended to embrace all legitimate meanings of the terms. They are applicable only to the subject treated in this standard.

Capacity. The maximum activity in curies (becquerels) specified for a given radionuclide that may be contained in an exposure device.

Collimator. A device used to limit the size, shape, and direction of the primary radiation beam.

Control. A mechanism attached to an exposure device that, upon actuation, causes the source to be exposed or retracted. Controls may be operated either manually or by a suitable source of power.

Exposure Device. A shield in the form of a package designed to contain and allow the controlled use of one or more sources for the purpose of making radiographic exposures.

Exposure Head. A device which locates the sealed source at the desired focal position. It may be a separable unit or an integral part of a source guide tube.

Gamma Radiography System. All components necessary to make radiographic exposures, including the exposure device, source assembly, control, and other components associated with positioning the

source such as source guide tubes, exposure head, and collimators, if used.

Prototype. The initial manufactured unit conforming in all vital characteristics to units manufactured subsequently.

Sealed Source. Radioactive material packaged in one or more capsules sealed to prevent escape of the radioactive material. The capsule or capsules are essentially transparent to the desired radiation.

Source Guide Tube (Conduit). A flexible or rigid tube for guiding the sealed source from the exposure device to the exposure head.

Source Assembly. A component to which the sealed source is affixed or in which the sealed source is contained. The source assembly includes the sealed source.

3. Classification

For the purposes of this standard, apparatus for gamma radiography is classified according to handling and operational characteristics.

3.1 Handling Characteristics of Exposure Devices

Exposure devices are classified to one of three categories according to their handling characteristics:

3.1.1 Class P: Portable Exposure Device. This is a device which is designed to be carried by one person.

3.1.2 Class M: Mobile Exposure Device. This is a device which is designed to be moved by a suitable means provided for the purpose, but is not portable.

3.1.3 Class F: Fixed Exposure Device. This is a device which is designed to be installed in a fixed location or with mobility restricted to a particular working area.

3.2 Operational Characteristics of Exposure Devices

Exposure devices are classified to one of two categories according to their operational characteristics.

3.2.1 Type 1 Exposure Device. This is a device which allows the source to move out of the device to an essentially unshielded position. This type of exposure device requires the use of a remote control and an exposure head, and may use source guide tubes.

3.2.2 Type 2 Exposure Device. This is a device which does not allow the source to be removed from the device, but exposes the source by opening a shutter or moving the source to an exposed position within the device, allowing a limited beam to emerge.

3.3 Operational Characteristics of Controls

Controls are classified to one of two categories according to their operational characteristics.

3.3.1 Type R: Remote Control. This is a control which allows actuation of the source assembly from a position remote from the exposure device. This type of control may be used on either Type 1 or Type 2 exposure devices.

3.3.2 Type L: Local Control. This is a control which allows actuation of the source assembly at the location of the exposure device. This type of control may be used only on Type 2 exposure devices.

4. Marking and Identification

4.1 Exposure devices shall be marked with the basic ionizing radiation symbol, complying with ANSI N2.1-1969 and 10CFR20.203. The trefoil symbol shall be magenta on yellow background and not less than 25 mm in diameter. The exposure device shall also bear the words "Caution Radioactive Material" in letters not less than 10 mm in height. The trefoil symbol and this lettering shall be embossed, etched, engraved, or otherwise impressed upon the surface so that it remains legible should the paint or coloring be removed.

4.2 The marking of the device shall also show the manufacturer's name, model number, serial

number, the rated capacity in curies (becquerels), and radionuclide. If uranium is employed as shielding, the device shall be so marked and the mass of the uranium shown. Exposure devices shall be marked with the mass of the device without removable accessories. Provision shall be made for the attachment of a plate bearing the following information:

- A) Chemical symbol and mass number of the radionuclide
- B) Activity and the date on which this activity was measured
- C) Model number and serial number of the sealed source
- D) Manufacturer of sealed source

5. Design and Construction of Exposure Devices

An exposure device shall be designed and constructed to conform to the requirements below for its class and type. The general requirements apply to all classes and types.

5.1 General Requirements

5.1.1 Design Considerations. Exposure devices shall be designed with due regard for the conditions which may be encountered during use, such as:

- a. The durability and resistance to corrosion of components and their surface finishes, particularly where the functioning of controls or moving parts may be affected.
- b. The need to minimize entry of water, mud, sand, or other foreign matter into the controls or moving parts.
- c. The ease with which the apparatus may be safely cleaned.
- d. The effects of temperatures that may be encountered in use.
- e. The possibly damaging effects of radiation on any materials in close proximity to the sealed source.
- f. The provision of appropriate accessories designed for the secure mounting of the exposure device or exposure head in different conditions of use.
- g. The security of any fasteners whose loosening or loss could cause hazards.

5.1.1.1 When depleted uranium is used as the shielding material of an exposure device, it shall

be clad or encased with a material of sufficient thickness to prevent abrasion of the uranium and contain any products of corrosion of the uranium. If the cladding is liable to react with the depleted uranium at elevated temperatures, then the uranium shall be given a suitable surface treatment to inhibit this effect.

5.1.2 Locks

5.1.2.1 The exposure device shall have a lock which is not easily removable by unauthorized personnel.

5.1.2.2 When the exposure device is locked, it shall not be possible to remove the source assembly from the exposure device or to move the shielding so as to expose the sealed source.

5.1.2.3 It shall not be possible to unlock the exposure device with an easily available substitute for the key.

5.1.2.4 It shall not be possible to operate the lock unless the source assembly is in the fully shielded position.

5.1.2.5 It shall not be possible to remove the source assembly through the back of the exposure device even when the exposure device is unlocked.

5.1.3 Connections. The exposure device shall be equipped with means for secure attachment of the control and source guide tube. If the connections for the control and guide tube are similar, erroneous interchange shall not result in exposure of the sealed source.

5.1.4 Tests. A prototype exposure device shall be subjected to the test conditions applicable to its class as delineated in table 5.1.

TABLE 5.1

Section	Test	P	M	F
8.1	Shielding Efficiency	X	X	X
8.2	Horizontal Shock	X		
8.3	Vertical Shock	X	X	
8.4	Accidental Drop	X	X	
8.9	Endurance	X	X	X

5.2 Additional Requirement for Class P Exposure Devices

Class P exposure devices shall be equipped with a handle or handles which permit carrying

by hand. Handles shall be of such construction and secured to the device in such a manner that failure and dropping of the container is prevented. Handles or other attachment points shall be suitable for hoisting.

5.3 Additional Requirements for Class M Exposure Devices

Class M exposure devices shall incorporate, or be adaptable to, a means for mobility, such as wheels, and shall be fitted with an immobilization device. Mobile devices shall also be equipped with a means for hoisting.

6. Design and Construction of Controls

A control shall be designed and constructed to conform to the requirements below for its class. The general requirements apply to all classes.

6.1 General Requirements

6.1.1 Controls shall be designed such that they cannot be removed unless the source assembly is in the stored position OR removal of the control shall cause the source assembly to return to the stored position.

6.1.2 Controls shall be clearly marked to indicate the direction of control movement to expose or retract the source.

6.1.3 Controls using a drive cable shall have a stop on the cable to prevent loss of control and disengagement of the cable from the drive. If the control incorporates a device to indicate drive cable travel distance, there shall be means of adjusting the "zero" position.

6.1.4 The control shall not allow exposure of the source if the control is not properly connected to the source assembly and exposure device.

6.1.5 Controls operating with liquid, gas, or vacuum shall incorporate means of determining system leaks and severance.

6.1.6 A prototype control shall be subjected to the test conditions applicable to its class as delineated in table 6.1.

TABLE 6.1

Section	Test	R	L
8.5	Kinking	X	
8.6	Crushing	X	
8.7	Tensile	X	
8.9	Endurance	X	X

6.2 Additional Requirement for Local Controls

Local controls shall be designed such that an operator can operate the control and remain outside the emergent beam of radiation.

7. Design and Construction of Source Assemblies

Source assemblies shall be designed and constructed to conform to the requirements listed below.

7.1 The source capsule shall be designed and tested to the applicable requirements of ANSI N542, Sealed Radioactive Sources, Classification.

7.2 The attachment of the source capsule to the source assembly and the attachments of the source connector and stop ball to the source assembly (if applicable) shall be designed to withstand a tensile load of 890 N.

7.3 Prototypes of source assemblies shall be subjected to the test conditions as delineated in table 7.1.

TABLE 7.1

Section	Test
8.8	Tensile
8.9	Endurance

8. Tests

Exposure devices, controls, and source assemblies shall be subjected to the applicable tests as required in tables 5.1 and 6.1, and in section 7.3.

8.1 Shielding Efficiency Test

8.1.1 **General.** The shielding efficiency test requires demonstration that the exposure device, when containing a source with activity equal to the maximum rated capacity of the device, does not produce radiation levels in excess of the values of table 8.1. The shielding efficiency test is to be performed with the source locked in the stored position within the device.

8.1.2 **Procedure.** Remove all accessories and perform the test on the exposure device with the source locked in the stored position and with storage plugs or caps installed if such closures are utilized.

With an appropriate radionuclide source of known activity (see Notes) examine the entire surface of the container to determine that the maximum radiation levels given in table 8.1 are not exceeded in any direction.

The measurement of an exposure rate at 50 mm from the surface shall be averaged over an area of 10 cm² with no linear dimension greater than 5 cm.

The measurement of an exposure rate at 1 m from the surface shall be averaged over an area of 100 cm² with no linear dimension greater than 20 cm.

In the case of a Class F exposure device, the exposure rates in any position inaccessible to parts of the operator's body need not be measured.

Note 1 The activity of the source shall be determined by measuring its output at 1 m and expressing its activity in curies (becquerels) derived from the following values:

¹⁹² Iridium:	0.48 R/h-Ci @ 1 m	(0.93 aA/kg-Bq @ 1 m)
⁶⁰ Cobalt:	1.30 R/h-Ci @ 1 m	(2.52 aA/kg-Bq @ 1 m)
¹³⁷ Cesium:	0.32 R/h-Ci @ 1 m	(0.62 aA/kg-Bq @ 1 m)
²²⁶ Radium:	0.82 R/h-Ci @ 1 m	(1.60 aA/kg-Bq @ 1 m)

For other radionuclides, the value determined by a qualified organization should be used.

Note 2 The activity of the source used in the test shall be chosen such that a valid extrapolation can be made. The extrapolation should not exceed a factor of 10.

TABLE 8.1. *Maximum Exposure Rate*

Class	At surface	50 mm from surface	1 m from surface
P	200 mR/h (14.3 nA/kg)	or 50 mR/h (3.6 nA/kg)	2 mR/h (0.1 nA/kg)
M	200 mR/h (14.3 nA/kg)	or 100 mR/h (7.2 nA/kg)	5 mR/h (0.4 nA/kg)
F	200 mR/h (14.3 nA/kg)	or 100 mR/h (7.2 nA/kg)	10 mR/h (0.7 nA/kg)

8.2 Horizontal Shock Test

8.2.1 General. The horizontal shock test requires demonstration that the exposure device will withstand the horizontal impacts it is likely to experience during use. The exposure device and integral safety features shall remain operational after the test and shall experience no loss of shielding integrity.

8.2.2 Equipment. The target shall consist of the flat vertical face of a 50 mm diameter steel bar, 300 mm long, lying horizontally, which is fixed or welded to a rigid mass at least 10 times the mass of the exposure device.

The suspension device shall not cause undesirable rotation of the container around a vertical axis when it is suspended.

8.2.3 Procedure. Remove all accessories and perform the test on the exposure device with the source assembly locked in the stored position and with storage plugs or caps installed if such closures are utilized.

Select the fragile areas on the exposure device. Suspend the exposure device from fixed points so placed that, when at rest, one of the fragile areas just touches the target.

Move the exposure device from its resting position until the altitude of its center of gravity increases by 100 mm, then let it swing in a pendulum movement against the target.

Repeat these shocks 20 times on each of the areas of the device regarded as fragile.

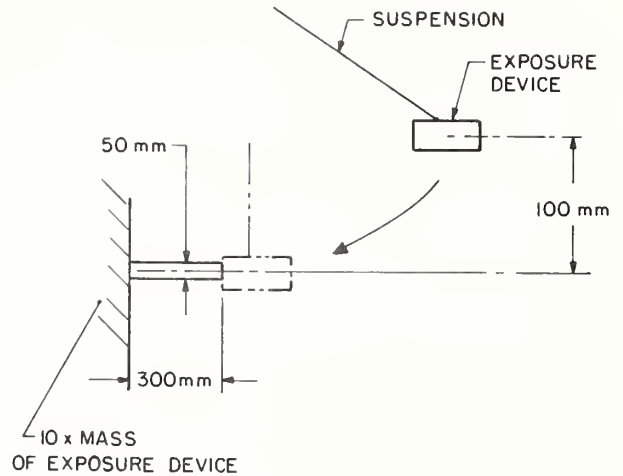

FIGURE 8.1 *Horizontal shock test*

8.3 Vertical Shock Tests

8.3.1 General. The vertical shock tests require demonstration that the exposure device will withstand the vertical impacts it is likely to experience during use. Class P exposure devices shall be subjected to the tests of section 8.3.2. Class M exposure devices shall be subjected to the tests of section 8.3.3.

The exposure device and integral safety features shall remain operational after the test and the device shall experience no loss of shielding integrity.

The tests shall be performed on the exposure device with all accessories removed, with the source assembly locked in the stored position and with storage plugs or caps installed if such closures are utilized.

8.3.2 Vertical Shock Test for Class P Devices

8.3.2.1 Equipment. The rigid target (for example steel, concrete, or solid timber) shall have a mass at least 10 times that of the exposure device and a flat horizontal surface covered with a sheet of 7 or 9 ply (25 mm thick) fir plywood or equivalent.

8.3.2.2 Procedure. From its normal carrying position, let the exposure device fall 100 times from a height of 150 mm onto the rigid target.

The test may be carried out either manually or with the aid of a suitable mechanical device.

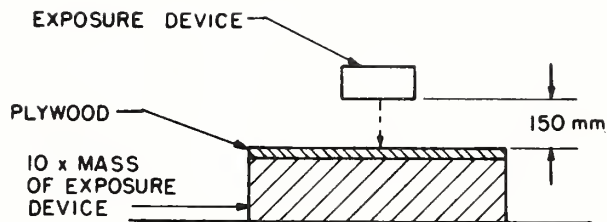

FIGURE 8.2 Vertical shock test (Class P)

8.3.3 Vertical Shock Test for Class M Devices

8.3.3.1 Equipment. The step shall have a height of 150 mm with a rigid edge such that it will not be distorted during the test.

8.3.3.2 Procedure. Allow the exposure device, on its trolley or other equipment provided for mobility, moving at a speed of at least 1 m/s, to drop freely down the step.

Repeat the test 100 times.

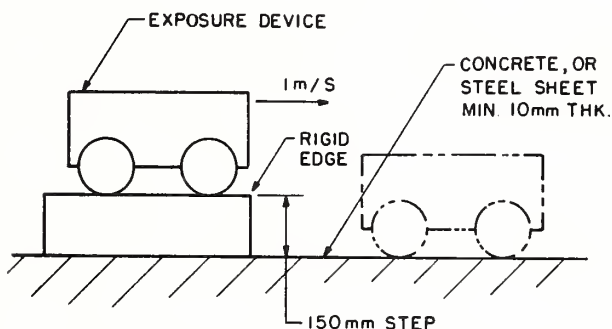

FIGURE 8.3 Vertical shock test (Class M)

8.4 Accidental Drop Tests

8.4.1 General. The accidental drop tests require demonstration that the exposure device will withstand hypothetical accident conditions without exposing the source. The exposure device does not need to be operational after the tests.

At the conclusion of each drop test, the shielding efficiency shall be sufficient to maintain the external radiation exposure rate at not more than 1000 mR/h (72 nA/kg) at 1 m from the external surface of the exposure device when containing a source with an activity equal to the maximum rated capacity of the device, and the integrity of the sealed source shall be maintained.

The tests shall be performed on the exposure device with all accessories removed, with the source assembly locked in the stored position and with storage plugs or caps installed if such closures are utilized. (This test may be performed using a source assembly which does not contain radioactive material.)

8.4.2 Equipment. For Drop 1, the target shall consist of a flat horizontal surface of such character that any increase in its resistance to displacement or deformation upon impact by the container would not significantly increase the damage to the container.

One example of a target of this type is a steel plate on the upper surface of a block of concrete of mass at least 10 times that of any specimen to be dropped onto it. The block should be set on firm soil and the steel plate on its upper surface should be at least 12.5 mm thick.

For Drop 2, the target shall consist of the upper end of a solid mild steel bar of circular cross section, 150 mm \pm 5 mm in diameter with edges rounded to a radius of not more than 6 mm. The target shall be at least 200 mm long and of sufficient length to cause maximum damage. The target shall be rigidly mounted on the target for Drop 1, and its axis shall be perpendicular to the Drop 1 target plane.

8.4.3 Procedure—Drop 1. Allow the exposure device to free-fall onto the target in such an attitude as to suffer the maximum damage.

The height of fall measured from the lowest point of the exposure device to the upper surface of the target shall be 9 m.

8.4.4 Procedure—Drop 2. Allow the exposure device to free-fall onto the target in such an attitude as to suffer the maximum damage.

The height of fall measured from the intended point of impact of the exposure device to the upper surface of the target shall be 1 m.

8.5 Kinking Test

8.5.1 General. The kinking test requires demonstration that the control cable will withstand conditions it is likely to experience during use. The control cable shall remain operational after the test.

8.5.2 Procedure. Arrange the remote control cable and sheath(s) rectilinearly on a plane horizontal surface. Secure one end of the

sheath(s) so that it does not move in any way during the test. With the sheath make a loop 500 mm in radius on the horizontal surface. Pull the free end of the sheath(s), without allowing it to rotate, along the axis of its original line at a speed of 2.0 m/s until the loop has disappeared and until the sheath(s) has regained its rectilinear position.

Repeat this test 10 times at each of 10 equidistant points over the length of the sheath or sheaths tested, each point being the origin of the loop.

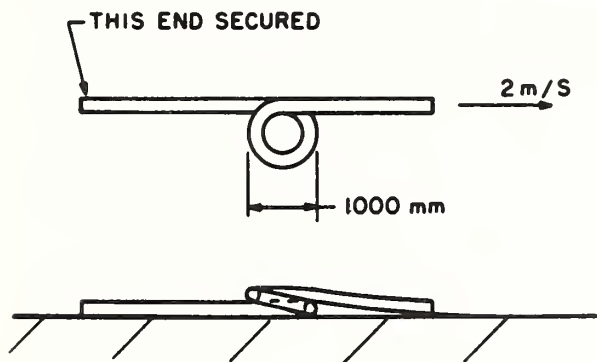

FIGURE 8.4 Kinking test

8.6 Crushing Test

8.6.1 General. The crushing test requires demonstration that the control unit will remain operational after being impacted by the heel of a walking man.

8.6.2 Equipment. The plane horizontal test surface shall be of mass 150 kg and sufficiently hard not to be deformed by the steel punch applied without the presence of the object to be tested.

The steel punch, called a heel, shall be of mass 15 kg divided equally between the heel and the arm, with the arm having a uniform cross section as shown in figure 8.5 adequately rigid for the test, with the crank axle horizontal.

8.6.3 Procedure. Place the heel at a point on the sheath. By lifting the punch, raise the bottom of the heel 300 mm. Drop the punch in a free-swinging movement. Repeat this test 10 times on randomly selected points of the sheath, one of which shall be made at a joint if there is one.

Dimensions in millimetres

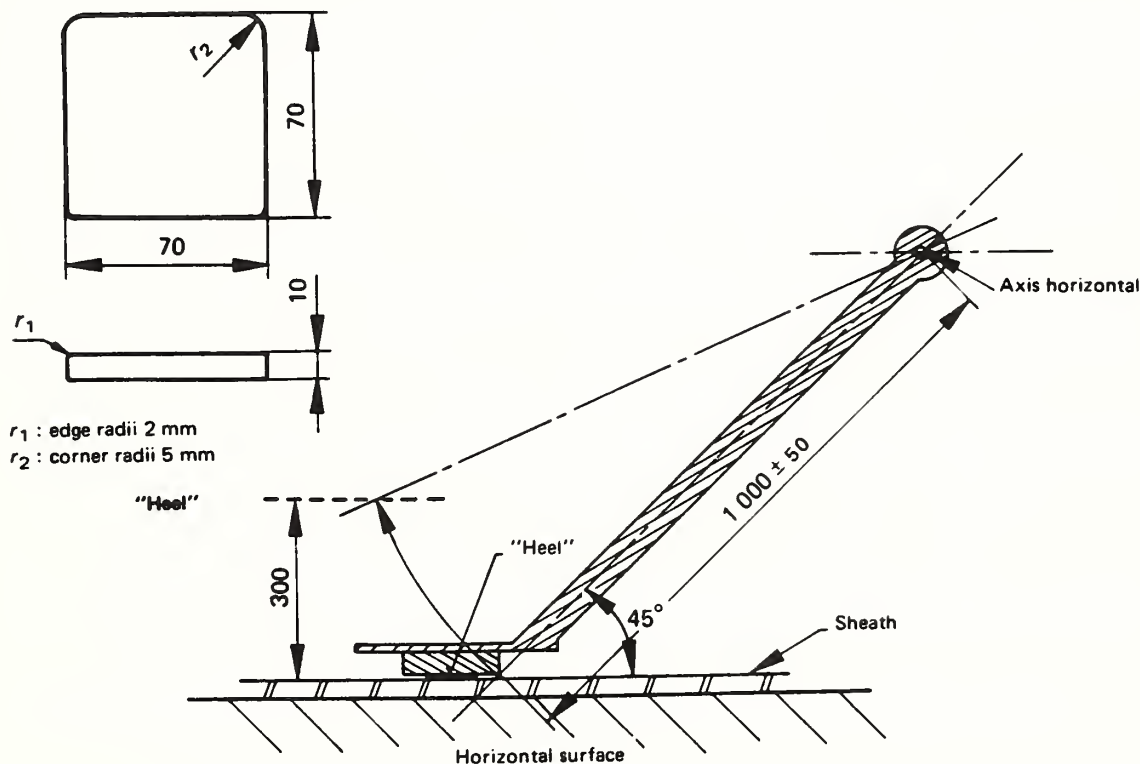

FIGURE 8.5 Crushing test

8.7 Tensile Test for Controls

8.7.1 General. The tensile test requires demonstration that the control will remain operational after experiencing tensile loads likely to be applied during use.

8.7.2 Procedure. Attach the remote control to the exposure device and secure the exposure device so that it does not move during the test. To the final position of the remote control apply a tensile load of 500 N for 30 s. Repeat this test 10 times.

Secure the remote control so that it does not move during the test. Lock the control lever, for example the crank, in relation to the mechanism. Apply a force of 1000 N for 10 s to the end portion of the remote control cable which links with the source assembly. Repeat this test 10 times.

8.8 Tensile Test for Source Assemblies

8.8.1 General. The tensile test requires demonstration that the source assembly will maintain its integrity after experiencing tensile loads likely to be applied during use.

8.8.2 Procedure. Apply a tensile load of 890 N for 30 s to each of the following attachments (if applicable).

- Sealed Source to Source Assembly
- Stop Ball to Source Assembly
- Source Assembly Connector to Source Assembly

Connect the drive cable to the source assembly. Secure the source capsule and apply a tensile load of 890 N to the drive cable for 30 s.

8.9 Endurance Test

8.9.1 General. The endurance test requires demonstration that the gamma radiography

system will remain operational after 20,000 cycles.

8.9.2 Equipment. A device shall be used for automatically actuating the apparatus, according to the manufacturer's instructions:

(a) by moving any manually operated lever on the apparatus from one extreme position to the other in 1 s.

(b) by rotating any manually operated crankshaft at a speed of 1 r/s minimum.

(c) when no overload clutch is built into the apparatus, by exerting a torque of $500L$ N·m instantaneously to the lever or crankshaft at both extremities of its normal movement, where L is the length, in meters, of the lever or crankshaft; or when an overload clutch is built into the apparatus, by exerting a torque, equivalent to the highest transmissible to the apparatus by the built-in clutch, instantaneously to the lever or crankshaft at both extremities of its normal movement. During this test, the overload clutch is suitably locked in the engaged position.

8.9.3 Procedure. Connect the automatic testing device to the fully equipped system.

Check that the movement speeds and instantaneous extremity torques are adjusted.

Place the exposure container in such a way that any remote control cable fitted with its source holder is approximately in a straight line.

Fit the source guide tube of the largest diameter and maximum length specified by the manufacturer of the apparatus and attach the exposure head. Place this casing in a horizontal line.

Perform 20,000 operation cycles of the gamma radiography system.

At the conclusion of this test, perform the tensile test of section 8.8 on the source assembly and drive cable used for the endurance test.

Appendix A

Product Assurance

(This appendix is not a part of N432, Radiological Safety for the Design and Construction of Apparatus for Gamma Radiography.)

A1. General

A Product Assurance program is essential in both the design and manufacture of radioisotope exposure devices. Each manufacturer of such devices should develop a Quality program appropriate to the complexity and quantity of devices being designed and manufactured. A recommended basic program follows.

A2. Design Control

A2.1 The designated Quality Assurance Group should provide to a designer those various regulations, standards, etc., that the proposed design must meet. This may be done in the form of lists or charts, which provide the designer guidelines from which to develop the device in accordance with regulatory and standards requirements.

A2.2 Prior to prototype manufacture, the designated Quality Assurance Group should review preliminary working drawings and proposed production specifications, including material specifications, to assure that the requirements of pertinent regulations, standards, etc., have been incorporated in the design. This review should be recorded as a design verification and serve as the basis or authority to continue the design sequence or stop and rework the design.

A2.3 A complete set of records, verifying design calculations (shielding), mechanical/electrical operating characteristics, equipment lifetimes, radionuclides to be used in the device, capacity (in curies) of the device, proposed operating characteristics, proposed maintenance requirements, etc., should be permanently maintained.

A3. Prototype Testing

A3.1 All new exposure devices and accessory equipment designs should undergo a prototype test by the manufacturer.

A3.2 The prototype test should include those tests that may be required to meet the regulatory or standards requirements.

A3.3 A detailed record of the prototype test parameters, and the results of each individual test should be preserved and maintained for the life of the product.

A3.4 Prototype tests should be conducted by qualified personnel, and all test results should be documented and certified.

A4. Manufacturing Control

A4.1 Exposure devices must be fabricated to an engineering drawing and an appropriate set of specifications, which includes a bill of material.

A4.2 The engineering drawing and specifications must list all pertinent dimensions, material specifications, tolerances, in-process testing, and required fabrication techniques.

A4.3 An assembly work order, or traveler, should be maintained for each exposure device or “lot” of devices to be manufactured at one time. The work order should include all pertinent fabrication records such as materials used, fabrication techniques and processes, and in-process inspection and tests performed.

A4.4 Equipment and Procedures. The manufacturer should have written procedures for welding, nondestructive testing, heat treating, destructive tests, and other inspections performed on the product.

A4.5 Personnel Qualification. The manufacturer should only use personnel who have been appropriately trained and qualified to perform the various fabrication or inspection techniques.

A4.6 Materials Control. All incoming material and components should be receipt inspected to assure they adequately meet the requirements of the specification or drawing. The materials control program should provide traceability of major components of the assembly such as vendor-fabricated shields, lock boxes, drive assemblies, drive motors, gear boxes, etc.

A4.7 Product Conformance

A4.7.1 The manufacturer should establish acceptance criteria for each model or style of device manufactured. The acceptance criteria should include manufacturing/workmanship levels of acceptance, in addition to tests or inspections that assure that the production device is built according to engineering specifications and performs equivalent to the prototype.

A4.7.2 Items which are nonconforming and fail to meet the acceptance criteria should be identified and segregated. A procedure for performing rework to bring the item back into conformance should be established.

A5. Product Assurance Manual

A5.1 A Product Assurance Manual should be developed and maintained by each manufacturer of gamma radiography systems. The manual should contain procedures or reference procedures covering each facet of the Quality Program. Areas that should be covered are: Nondestructive Testing Procedure, Nonconforming Items Control, Equipment Calibration, Quality Organization and Policy, Internal Audits, Welding Procedures, Fabrication Procedures, Personnel Qualification Procedures, Materials Selection, and Control Procedures.

A5.2 All personnel involved in the manufacture of gamma radiography systems should have ready access to the Product Assurance Manual.

U.S. DEPT. OF COMM. BIBLIOGRAPHIC DATA SHEET	1. PUBLICATION OR REPORT NO. NBS Handbook 136	2. Gov't. Accession No.	3. Recipient's Accession No.
4. TITLE AND SUBTITLE American National Standard N432, Radiological Safety for the Design and Construction of Apparatus for Gamma Radio- graphy		5. Publication Date January 1981	
7. AUTHOR(S) Committee N43; E.H. Eisenhower, Chairman		6. Performing Organization Code	
9. PERFORMING ORGANIZATION NAME AND ADDRESS NATIONAL BUREAU OF STANDARDS DEPARTMENT OF COMMERCE WASHINGTON, DC 20234		8. Performing Organ. Report No.	
12. SPONSORING ORGANIZATION NAME AND COMPLETE ADDRESS (Street, City, State, ZIP) Same as item 9		10. Project/Task/Work Unit No.	
15. SUPPLEMENTARY NOTES <input type="checkbox"/> Document describes a computer program; SF-185, FIPS Software Summary, is attached.		11. Contract/Grant No.	
16. ABSTRACT (A 200-word or less factual summary of most significant information. If document includes a significant bibliography or literature survey, mention it here.) This standard applies to the design and construction of apparatus used for industrial gamma radiography which employs radioactive material as the energy source. It establishes the criteria to be used in the proper design and construction of the various components to ensure a high degree of radiation safety at all times. This includes the classification and labeling criteria for the exposure device; and factors which should be considered in the design and construction of exposure devices, controls, and source assemblies. The testing procedures and equipment for the various classifications of the exposure devices and source assemblies are detailed.		13. Type of Report & Period Covered Final	
14. Sponsoring Agency Code		17. KEY WORDS (six to twelve entries; alphabetical order; capitalize only the first letter of the first key word unless a proper name; separated by semicolons) Classification criteria; gamma radiography; national standard; performance tests; radiation source; safety standard	
18. AVAILABILITY <input checked="" type="checkbox"/> Unlimited <input type="checkbox"/> For Official Distribution. Do Not Release to NTIS <input checked="" type="checkbox"/> Order From Sup. of Doc., U.S. Government Printing Office, Washington, DC 20402. <input type="checkbox"/> Order From National Technical Information Service (NTIS), Springfield, VA. 22161		19. SECURITY CLASS (THIS REPORT) UNCLASSIFIED	21. NO. OF PRINTED PAGES 19
20. SECURITY CLASS (THIS PAGE) UNCLASSIFIED		22. Price \$1.50	

USCOMM-DC

OTHER PUBLICATIONS BY COMMITTEE N43

Order the following publications by SD Stock

Number from:

Superintendent of Documents

U.S. Government Printing Office

Washington, D.C. 20402

AMERICAN NATIONAL STANDARD N43.1;
RADIOLOGICAL SAFETY IN THE DESIGN AND
OPERATION OF PARTICLE ACCELERATORS.

NBS Handbook 107, Revised 1978.

SD Stock No. 003-003-02064-8

AMERICAN NATIONAL STANDARD N43.2;
RADIATION SAFETY FOR X-RAY DIFFRACTION AND
FLUORESCENCE ANALYSIS EQUIPMENT.

NBS Handbook 111, Revised 1977.

SD Stock No. 003-003-01917-8

AMERICAN NATIONAL STANDARD N543;
GENERAL SAFETY STANDARD FOR INSTALLATIONS
USING NON-MEDICAL X-RAY AND SEALED GAMMA-
RAY SOURCES, ENERGIES UP TO 10 MEV.

NBS Handbook 114.

SD Stock No. 003-003-01377-3

AMERICAN NATIONAL STANDARD N540;
CLASSIFICATION OF RADIOACTIVE SELF-LUMINOUS
LIGHT SOURCES.

NBS Handbook 116.

SD Stock No. 003-003-01456-7

AMERICAN NATIONAL STANDARD N537;
RADIOLOGICAL SAFETY STANDARD FOR THE DESIGN
OF RADIOGRAPHIC AND FLUOROSCOPIC INDUSTRIAL
X-RAY EQUIPMENT.

NBS Handbook 123.

SD Stock No. 003-003-01820-1

AMERICAN NATIONAL STANDARD N542;
SEALED RADIOACTIVE SOURCES, CLASSIFICATION.

NBS Handbook 126.

SD Stock No. 003-003-01903-8

AMERICAN NATIONAL STANDARD N433.1;
SAFE DESIGN AND USE OF SELF-CONTAINED, DRY SOURCE
STORAGE GAMMA IRRADIATORS (Category I).

NBS Handbook 127.

SD Stock No. 003-003-01913-5

AMERICAN NATIONAL STANDARD N538;
CLASSIFICATION OF INDUSTRIAL IONIZING
RADIATION GAUGING DEVICES.

NBS Handbook 129.

SD Stock No. 003-003-02135-1

U.S. DEPARTMENT OF COMMERCE
National Bureau of Standards
Gaithersburg, MD 20899

Form Number

Price to Consumer \$300

POSTAGE AND FEES PAID
U.S. DEPARTMENT OF COMMERCE
COM-215



SPECIAL FOURTH-CLASS RATE
BOOK
