



THE
AMERICAN
JOURNAL OF SCIENCE.

EDITOR: EDWARD S. DANA.

ASSOCIATE EDITORS

PROFESSORS GEO. L. GOODALE, JOHN TROWBRIDGE,
H. P. BOWDITCH AND W. G. FARLOW, OF CAMBRIDGE,

PROFESSORS O. C. MARSH, A. E. VERRILL AND H. S.
WILLIAMS, OF NEW HAVEN,

PROFESSOR GEORGE F. BARKER, OF PHILADELPHIA,
PROFESSOR H. A. ROWLAND, OF BALTIMORE,
MR. J. S. DILLER, OF WASHINGTON.

FOURTH SERIES.

VOL. IV—[WHOLE NUMBER, CLIV.]

WITH XII PLATES.

NEW HAVEN, CONNECTICUT.

1897.

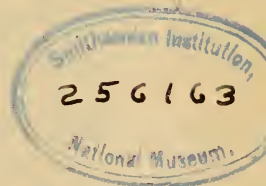

THE TUTTLE, MOREHOUSE & TAYLOR PRESS,
NEW HAVEN, CONN.

CONTENTS TO VOLUME IV.

Number 19.

| | Page |
|--|------|
| ART. I.—Pressure Coefficient of Mercury Resistance; by A. DEF. PALMER, Jr. | 1 |
| II.—Ctenacanthus Spines from the Keokuk Limestone of Iowa; by C. R. EASTMAN | 10 |
| III.—Studies in the Cyperaceæ, V.; by T. HOLM | 13 |
| IV.—Identity of Chalcostibite (Wolfsbergite) and Guejarite, and on Chalcostibite from Huanchaca, Bolivia; by S. L. PENFIELD and A. FRENZEL | 27 |
| V.—Interesting Case of Contact Metamorphism; by H. W. FAIRBANKS | 36 |
| VI.—Tin Deposits at Temescal, Southern California; by H. W. FAIRBANKS | 39 |
| VII.—Outlying Areas of the Comanche Series in Oklahoma and Kansas; by T. W. VAUGHAN | 43 |
| VIII.—Electrosynthesis; by W. G. MIXTER | 51 |
| IX.—Monazite from Idaho; by W. LINDGREN | 63 |

SCIENTIFIC INTELLIGENCE.

Chemistry and Physics—Viscosity of Mixtures of Miscible Liquids, THORPE and RODGER: Specific Heats of the Gaseous Elements, BERTHELOT, 65.—Synthetic Action of the Dark Electric Discharge, LOSANITSCH and JOVITSCHITSCH: Structural Isomerism in Inorganic Compounds, SABANÉEFF, 66.—Phase Rule, W. D. BANCROFT, 67.—Vorlesungen über Bildung und Spaltung von Doppelsalzen, 68.—Limits of Audition, LORD RAYLEIGH, 69.—Polarization Capacity, C. M. GORDON: Oscillatory Currents arising in Charging a Condenser, SEILER: Cathode Rays, 71.—Application of the Röntgen Rays to Surgery: Transparency of Ebonite, M. PERRIGOT: Theory of Electricity and Magnetism, A. G. WEBSTER, 72.—Light and Sound, E. L. NICHOLS and W. S. FRANKLIN, 73.

Geology and Mineralogy—Examination of Deposits obtained from borings in the Nile Delta, J. W. JUDD, 74.—Underground Temperatures at Great Depths, W. HALLOCK: Depth of Peat in the Dismal Swamp, G. R. WIELAND: Currituck Sound, Virginia and North Carolina, G. R. WIELAND, 76.—Papers on Dæmonelix: Genesis and Matrix of the Diamond, LEWIS and BONNEY, 77.—Transactions of the Geological Society of South Africa: Geological Survey of Canada, G. C. HOFFMANN, 78.

Botany—New System of Classification of Phænogamia, VAN TIEGHEM, 79.

Miscellaneous Scientific Intelligence—Cause of Secondary Undulations Registered on Tide Gauges, 82.—Zoölogical Bulletin, 83.

Obituary—ALVAN GRAHAM CLARK, 83.—CARL REMIGIUS FRESENIUS, 84.

Number 20.

| | Page |
|--|------|
| ART. X.— <i>Tamiobatis vetustus</i> ; a new Form of Fossil Skate; by C. R. EASTMAN. (With Plate I.) | 85 |
| XI.—Florenzia Formation; by O. H. HERSHEY | 90 |
| XII.—Native Iron in the Coal Measures of Missouri; by E. T. ALLEN | 99 |
| XIII.—Bixbyite, a new Mineral, and Notes on the Associated Topaz; by S. L. PENFIELD and H. W. FOOTE | 105 |
| XIV.—Composition of Ilmenite; by S. L. PENFIELD and H. W. FOOTE | 108 |
| XV.—Separation of Aluminum and Beryllium by the action of Hydrochloric Acid; by F. S. HAVENS | 111 |
| XVI.—Igneous Rocks of the Leucite Hills and Pilot Butte, Wyoming; by W. CROSS | 115 |
| XVII.—Stylolites; by T. C. HOPKINS | 142 |
| XVIII.—Extinct Felidæ; by G. I. ADAMS | 145 |

SCIENTIFIC INTELLIGENCE.

Chemistry and Physics—Electrical Convection of certain Dissolved Substances, PICTON and LINDER, 150.—Phenomena of Supersaturation and Supercooling, OSTWALD: Thermochemical Method for determining the Equivalents of Acids and Bases, BERTHELOT, 151.—Action of Potassium and Sodium vapor in coloring the Haloid salts of these metals, GIESEL: Action of the Silent Electric Discharge on Helium, BERTHELOT, 152.—Further Note on the Influence of a Magnetic Field on Radiation Frequency, LODGE and DAVIES, 153.

Geology and Mineralogy—Recent publications of the U. S. Geological Survey, 155.—Pleistocene Features and Deposits of the Chicago Area, F. LEVERETT, 157.—A new fossil Pseudoscorpion, H. B. GEINITZ: *Catalogus Mammalium tam viventium quam fossilium*, É.-L. TROUSSERT: Brief Notices of some recently described Minerals, 158.—The Bendegó Meteorite, O. A. DERBY, 159.

Miscellaneous Scientific Intelligence—American Association for the Advancement of Science, 160.—Development of the Frog's Egg, an Introduction to Experimental Embryology, T. H. MORGAN, 161.

Obituary—ALFRED M. MAYER, 161.—A. DES CLOIZEAUX: JULIUS SACHS, 164.

Number 21.

| | Page |
|--|------|
| ART. XIX.—Principal Characters of the Protoceratidæ; by O. C. MARSH. Part I. (With Plates II-VII.)..... | 165 |
| XX.—Theory of Singing Flames; by H. V. GILL..... | 177 |
| XXI.—Electrical Discharges in Air; by J. TROWBRIDGE... .. | 190 |
| XXII.—Oscillatory discharge of a large Accumulator; by J. TROWBRIDGE | 194 |
| XXIII.—Jura and Neocomian of Arkansas, Kansas, Okla- homa, New Mexico and Texas; by J. MARCOU..... | 197 |
| XXIV.—Pithecanthropus erectus; by L. MANOUVRIER. Translated by George Grant MacCurdy..... | 213 |
| XXV.—Titration of Sodium Thiosulphate with Iodic Acid; by C. F. WALKER... .. | 235 |
| XXVI.—Solarization effects in Röntgen Ray Photographs; by W. L. ROBB. (With Plates VIII-X.)..... | 243 |
| XXVII.—Cape Fairweather Beds, a new marine Tertiary Horizon in Southern Patagonia; by J. B. HATCHER ... | 246 |

SCIENTIFIC INTELLIGENCE.

Natural History—New Series of Contributions from the Gray Herbarium of Harvard University. No. XI, J. M. GREENMAN: Synoptical Flora of North America, Vol. 1. Part I, 249.—Illustrated Flora of the Northern United States, Canada, and the British Possessions, N. L. BRITTON and A. BROWN: Guide to the Genera and Classification of the North American Orthoptera found north of Mexico, S. H. SCUDDER: Das Tierreich, E. HARTERT, 250.

Miscellaneous Scientific Intelligence—American Association for the Advancement of Science, 250.—Transactions of the American Microscopical Society, 256.

Number 22.

| | Page |
|---|------|
| ART. XXVIII.—Fractional Crystallization of Rocks; by G. F. BECKER..... | 257 |
| XXIX.—Eopaleozoic Hot Springs and the Origin of the Pennsylvania Siliceous Oölite; by G. R. WIELAND.... | 262 |
| XXX.—Conditions required for attaining Maximum Accu- racy in the Determination of Specific Heat by the Method of Mixtures; by F. L. O. WADSWORTH..... | 265 |
| XXXI.—Systematic position of <i>Crangopsis vermiformis</i> (Meek), from the Subcarboniferous rocks of Kentucky; by A. E. ORTMANN..... | 283 |
| XXXII.—New Species of the Palinurid-Genus <i>Linuparus</i> found in the Upper Cretaceous of Dakota; by A. E. ORTMANN..... | 290 |
| XXXIII.—Studies in the Cyperaceæ, VI.; by T. HOLM.... | 298 |
| XXXIV.—Improved Heliostat invented by Alfred M. Mayer; by A. G. MAYER..... | 306 |
| XXXV.—Pseudomorphs from Northern New York; by C. H. SMITH, JR..... | 309 |
| XXXVI.—Chemical Composition of Hamlinite and its Occurrence with Bertrandite at Oxford County, Maine; by S. L. PENFIELD..... | 313 |

SCIENTIFIC INTELLIGENCE.

Chemistry and Physics—Properties of Highly Purified Substances, SHENSTONE, 317.—Liquefaction of Fluorine, MOISSAN and DEWAR, 318.—Normal and Isopentane from American Petroleum. YOUNG and THOMAS: Heat of Combustion, MENDELÉEFF, 319.—Capillary constants of molten metals, H. SIEDENTOPF, 320.—Relations between the Geometric constants of a crystal and the Molecular Weight of its Substance, G. LINCK, 321.—Induction Coil in practical work, including Röntgen Rays, L. WRIGHT.

Miscellaneous Scientific Intelligence—British Association, 324.—Notes on Greenland glaciation, R. S. TARR: Revision of the Apodidæ, C. SCHUCHERT: New Meteorite from Canada, 325.—Observations on Popocatepetl and Ixtaccihuatl, O. C. FARRINGTON: L. Evolution régressive en Biologie et en Sociologie, J. DEMOOR, J. MASSART and E. VANDERNELE: Birds of Colorado, W. W. COOKE: Mammoth Cave of Kentucky: an illustrated Manual, H. C. HOVEY and R. E. CALL, 326.

Number 23.

| | Page |
|--|------|
| ART. XXXVII.—Geology of Southern Patagonia : by J. B. HATCHER | 327 |
| XXXVIII.—Some of the large Oysters of Patagonia; by A. E. ORTMANN. (With Plate XI.)..... | 355 |
| XXXIX. — Former Extension of the Appalachians across Mississippi, Louisiana, and Texas; by J. C. BRANNER.. | 357 |
| XL.—Combustion of Organic Substances in the Wet Way; by I. K. PHELPS..... | 372 |
| XLI.—Some Features of Pre-Glacial Drainage in Michigan; by E. H. MUDGE | 383 |

SCIENTIFIC INTELLIGENCE.

Chemistry and Physics—Verification of Dalton's law for Solutions, WILDERMANN, 387.—Spectrum of Silicon, A. DE GRAMONT: Spark Spectrum of Cyanogen, HARTLEY, 388.—Electrolytic Solution and Deposition of Carbon, COEHN, 389.—Conversion of Nitrites into Cyanides, KERP: Physics, Student's Manual for the Study Room and Laboratory, COOLEY: Action at a distance, P. DRUDE, 390.—Electrical tension at the poles of an induction apparatus, A. OBERBECK: Investigation of the Lenard Rays, TH. DES COUDRES: Behavior of rarified gases in approximately closed metallic receptacles in a high frequency field, H. EBERT and E. WIEDEMANN: Cathode Rays, J. J. THOMSON, 391.—Effect of Pressure on Wave Length, W. J. HUMPHREYS, 392.

Geology and Natural History—Recent publications of the U. S. Geological Survey, 392.—Alabama, Geological Survey, 393 —Canada, Geological Survey: Indiana, 21st Annual Report of Department of Geology and Natural Resources, 1896: Fossil Insects of the Cordaites shales of St. John, N. B., G. A. MATTHEW, 394. —Cape of Good Hope, 1st Annual Report of the Geological Commission, 1896: Glacial observations in the Umanak district, Greenland, G. H. BARTON: Les Variations de longueur des Glaciers dans les Régions arctiques et boréales, C. RABOT, 395.—Esquisses Séléniologiques, W. PRINZ, 396.—Experimental Morphology, C. B. DAVENPORT, 397.

Miscellaneous Scientific Intelligence—Geological Lectures of Harvard University, HANS REUSCH, 397.—Calculus for Engineers, J. PERRY: Ostwald's Klassiker der Exakten Wissenschaften, 398.

Obituary—VICTOR MEYER, 398.

Number 24.

| | Page |
|---|------|
| ART. XLII.—A Microsclerometer, for determining the Hardness of Minerals; by T. A. JAGGAR, JR. (With Plate XII.) | 399 |
| XLIII.—Recent Observations on European Dinosaurs; by O. C. MARSH | 413 |
| XLIV.—Sapphires from Montana, with special reference to those from Yogo Gulch in Fergus County; by G. F. KUNZ | 417 |
| XLV.—Corundum-bearing Rock from Yogo Gulch, Montana; by L. V. PISSON | 421 |
| XLVI.—Crystallography of the Montana Sapphires; by J. H. PRATT | 424 |
| XLVII.—Electrical Measurement by Alternating Currents; by H. A. ROWLAND | 429 |
| XLVIII.—The alleged Jurassic of Texas. A Reply to Professor Jules Marcou; by R. T. HILL | 449 |

SCIENTIFIC INTELLIGENCE.

- Chemistry and Physics*—Thermal Phenomena attending Change in Rotatory Power, BROWN and PICKERING, 470.—Chemical Action of Electrical Oscillations, DE HEMPTINNE, 471.—Explosion of Chlorine Peroxide with Carbon Monoxide, DIXON, 472.—Absorption of Nitrogen by Carbon compounds under the influence of the silent Electric Discharge, BERTHELOT: Manual of Qualitative Analysis, C. R. FRESENIUS, 473.—Delay in spark discharges, E. WARBURG: Photoelectric relations of Fluorspar and of Selenium, G. C. SCHMIDT, 474.—Magnetic method of showing metallic iron: Spectra of certain stars, VOGEL and WILSING: Structure of the Cathode Light and the nature of the Lenard Rays, GOLDSTEIN: New Nicol Prism, 475.
- Geology and Natural History*—Observations on Baffinland, R. BELL, 476.—International Geological Congress, 477.—Mineral Resources of the United States, 1895, D. T. DAY: Descriptive Catalogue of Useful Fiber Plants of the World, including the structural and economic classifications of fibers, C. R. DODGE, 478.
- Miscellaneous Scientific Intelligence*—Natural Academy of Sciences, 479.—Cordoba Photographs, B. A. GOULD: November Meteors: Sixteenth Annual Report of the Bureau of American Ethnology, J. W. POWELL, 480.—Field Columbian Museum: American Journal of Physiology, 481.
- INDEX, 482.

VOL. IV.

JULY, 1897.

Established by BENJAMIN SILLIMAN in 1818.

THE
AMERICAN
JOURNAL OF SCIENCE.

EDITOR: EDWARD S. DANA.

ASSOCIATE EDITORS

PROFESSORS GEO. L. GOODALE, JOHN TROWBRIDGE,
H. P. BOWDITCH AND W. G. FARLOW, OF CAMBRIDGE,

PROFESSORS O. C. MARSH, A. E. VERRILL AND H. S.
WILLIAMS, OF NEW HAVEN,

PROFESSOR GEORGE F. BARKER, OF PHILADELPHIA,

PROFESSOR H. A. ROWLAND, OF BALTIMORE,

MR. J. S. DILLER, OF WASHINGTON.

FOURTH SERIES.

VOL. IV—[WHOLE NUMBER, CLIV.]

No. 19.—JULY, 1897.

NEW HAVEN, CONNECTICUT.

1897.

TUTTLE, MOREHOUSE & TAYLOR, PRINTERS, 125 TEMPLE STREET.

Published monthly. Six dollars per year (postage prepaid). \$6.40 to foreign subscribers of countries in the Postal Union. Remittances should be made either by money orders, registered letters, or bank checks.

ENDLICHITE.

IN BEAUTIFUL CRYSTALLIZATIONS.

A rare variety of **Vanadinite**, having half of the Vanadium replaced by Arsenic. A small collection made at the locality and just purchased by us, embraces specimens which are vastly better than the few quickly sold eighteen months ago. In brilliant perfection and highly modified crystallization they fully equal the magnificent examples of the common variety of this well known species. The color of the new specimens ranges from delicate straw yellow to rich orange-red, the shading in groups or even single crystals giving a charming mottled effect.

Crystals are short tabular to acicular hexagonal prisms, terminated by basal plane, pyramid or both; and possess a marvelous lustre. An odd and novel type is where the basal plane of a tabular crystal is fringed by minute needle-like crystals of light color, standing parallel to the sides of the larger prism.

Prices are low. \$1.00 to \$4.00 for exquisite small groups of good sized crystals. Micro. mounts and single crystals, 50c. and 75c.

ANGLESITE, CERUSSITE AND PYROMORPHITE.

from the old Phoenixville mines. Through the purchase of a collection made back in the '60's we are enabled to sell choice examples of the rare and beautiful minerals of this historic locality 50c. to \$3.00 each. Also cheap microscopic specimens.

CUMBERLAND MINERALS

in unusually fine specimens. **Calcites** of new types, bright and gemmy **Blue Barite** grouped with **Calcite** in an attractive manner. **Aragonite**, **Witherite**, **Hematite with Quartz**, 25c. to \$4.00.

MIMETICAL PYRITE

Curious and interesting crystals which simulate the cube; from Daradagna, Italy. Described by Prof. Luigi Bombicci in an exhaustive illustrated memoir, 50c. to \$3.00.

FINE SULPHURS

Our stock of Sicilian Sulphurs, far excelling anything even in Europe, has been increased by another shipment containing some remarkable specimens. Prices $\frac{1}{2}$ to $\frac{3}{4}$ those formerly obtained. Also a new type of the same species from Northern Italy. **Poretta Cavernous Quartz**, **Aragonite**.

OTHER NEW ARRIVALS

Crystals of:—**Pyroaurite**, **Avalite**, **Monazite**, **Xenotime**, **Cleveite** and **Thorite**. Excellent **Herderites**, **Bertrandite**, **Limonite** after **Pyrite** in good groups. **Striated Garnets**. **Delaware Co. (Pa.) Amethysts**.

METEORITES

Section of the **Sacramento Mts. (N. M.) Iron** for sale. Also **Canyon Diablo Diamondiferous Iron** at lowest prices.

NATIVE IRON (TERRESTRIAL)

Pieces of the mass brought from Greenland and described by Baron Norden-skiold. \$2.00 to \$3.00 per pound. *Every mineral collection should show terrestrial and meteoric iron.*

COLLECTIONS OF MINERALS A SPECIALTY.

Laboratory Material.

Crystals.

Gems.

Prices on application.

Dr. A. E. FOOTE,

WARREN M. FOOTE, Manager.

1317 ARCH STREET,
PHILADELPHIA, PA., U. S. A.

Wm. D. Walcott

THE

AMERICAN JOURNAL OF SCIENCE

[FOURTH SERIES.]

ART. I.—*On the Pressure Coefficient of Mercury Resistance*;
by A. DEFOREST PALMER, JR.

DURING the last fifty years many physicists have investigated the specific resistance of mercury and its variations under different conditions, yet the only determinations of the pressure coefficient, previously published, are those of Barus,* who found $-.00003$ by subjecting commercial mercury to pressures up to 400 atmospheres, and Lenz,† who found $-.0002$ for pure mercury between one and sixty atmospheres. The discordance of these results is far too great to be explained by impurities in the mercury and invites further study.

The long range of pressure desired for the present investigation was easily obtained with Professor Barus's "Screw compressor." This instrument, together with the vertical piezometer employed in my work, has been so fully described elsewhere‡ that only a cursory mention is necessary here. The piezometer proper consists of a cold drawn seamless steel tube, about 6^{mm} internal and 13^{mm} external diameter and 60^{cm} long, connected to the compressor in such a manner that very perfect electrical insulation exists between the two without rendering the joint appreciably leaky. The whole apparatus was filled with heavy mineral oil which, though more viscous than water, attained uniformity of pressure with sufficient rapidity and possessed the advantage of being a very good insulator.

* Barus, this Journal, III, xl, p. 219, 1890.

† Lenz, Stuttgart, 1882; Wied. Beibl., vi, p. 802, 1882.

‡ Barus, Phil. Mag., Oct., 1890, p. 340; Proc. Amer. Acad., xxv, p. 93, 1890; Bull. U. S. Geological Survey, No. 96.

Moreover it is much easier to prevent leakage of oil than water and it has no detrimental effect on the steel parts with which it comes in contact. An Amagat "manomètre à pistons libres"* was used to determine the pressures attained and gave results within one-tenth per cent throughout the entire range. The ratio of its pistons is such that one millimeter difference in height of the mercury column supported by the larger corresponds to a difference of pressure of $\cdot 647$ atmospheres on the smaller. It is supplied with an open glass manometer three and one-half meters high and is therefore capable of indicating pressures somewhat greater than two thousand atmospheres, but above this limit a large element of uncertainty is introduced by leakage of oil around the pistons.

Commercial mercury was digested for about forty-eight hours in a solution of sulphuric acid and bichromate of potash in water and after being carefully washed, dried, and filtered, was distilled directly into the tubes in which its resistance was measured. An ordinary glass thermometer tube, about 18^{cm} long and 0.1^{mm} bore, had 10^{cm} of 2^{mm} bore tubing welded to its upper end in such a manner that a cavity, about 1^{cm} long and 4^{mm} in diameter, was formed between the two parts. This cavity and the elongated bulb at the lower end of the fine capillary had platinum electrodes melted through their walls and, when filled, formed the terminals of the mercury thread under investigation. The open end of the large tube was welded to a small glass mercury still connected, through a drying chamber, with a Geissler-Toepler air pump and the whole apparatus exhausted until the pressure fell below one millimeter. When the inside walls had become perfectly dry, heat was applied and mercury slowly distilled over and condensed in the experimental tube. As soon as this became full it was emptied and the operation repeated until the mercury thread, when examined with a magnifying glass, appeared perfectly bright and uniform throughout its entire length. Air was then admitted and the large capillary cut off about two centimeters from the point where it joined the still. After soldering silk insulated copper wires to the electrodes the tube was placed inside the steel piezometer and the upper wire connected directly to it, while the lower one, after passing down through a narrow glass tube, to insure good insulation, was soldered to the inside of the compressor. Oil was forced up into the piezometer and when its appearance at the top showed that all air had been expelled the opening was closed by a tinned steel screw.

The piezometer was surrounded by a long brass cylinder,

* Amagat, C. R., ciii, p. 429. 1886. Professor Tait has described a similar apparatus in the "Challenger Reports," 1873-76, Physics and Chemistry, vol. ii.

closed at the ends by rubber stoppers, through which water from the city mains was allowed to flow continuously. A thermometer with its bulb inside of this cooler showed that the temperature never varied more than one degree from 9° C. throughout the entire series of experiments and that the variations during the same day were very much less than this. For the measurements at the boiling point of water a tin can about 30^{cm} long and 13^{cm} in diameter, having short brass tubes soldered to apertures in the center of its ends, was placed on the piezometer and fastened, by short pieces of rubber tubing, in such a position that it entirely covered the experimental tube within. Two openings in the top were provided, one for the reception of a thermometer and the other for a vertical water condenser. The latter, being open at the top, kept the steam at atmospheric pressure and at the same time obviated the necessity of frequently renewing the supply of water. The whole arrangement with the exception of the bottom was covered with asbestos to prevent radiation and heat was applied by means of a ring burner surrounding the piezometer below the can. Small water coolers were placed above and below to prevent the conduction of heat through the steel tube to the joints where it might cause leaks.

Various methods for the measurement of resistance were tried with more or less success, but that due to Carey Foster was found to give the best results owing to its sensitiveness to small variations. The general arrangement of the apparatus for this method is too well known to need description here. The transposition of the standard and unknown resistances was accomplished by means of an eight pole mercury commutator similar to those put on the market by Nalder Bros. A series of platinoid coils, by Queen & Co., so arranged that their combined resistance could be varied by tenths from zero to ten thousand ohms, without altering the number of plugs in the circuit, was used as a standard with which to compare the mercury thread under investigation. As noted above, the electrodes of the thread were connected respectively to the piezometer and compressor, and since these parts were otherwise very perfectly insulated from one another they served admirably as poles from which to make connection with the commutator. A very uniform german silver wire, about No. 17 B. & S. gauge, was wound in ten uniform spirals about a vulcanite cylinder 10^{cm} in diameter and 3.6^{cm} long. Its ends were fastened, in the same generating line of the cylinder, to two thick brass plates that formed the ends of the drum and were rigidly fastened to two stout brass pillars which were connected with the poles of the commutator. An insulated frame work was arranged to revolve about this drum in such a man-

ner that a spring contact, which served as one terminal of the galvanometer, could be readily placed on any point of the wire and its position accurately determined by a large micrometer head divided into one hundred equal parts. This arrangement presents a great advantage over the ordinary form of drum bridge since the only friction connections are in the galvanometer circuit, where the worst effect they can produce is small variations in sensitiveness, and not, as they are usually placed, at the terminals of the wire, where changes in their resistance produce the maximum effect on the result. Current was supplied to the bridge by a single Daniell's cell and was so regulated by a small rheostat in series with the battery that its intensity was never sufficient to appreciably alter the temperature of the resistances in circuit. The attainment of balance was judged by a very sensitive and dead beat D'Arsonval galvanometer of the horizontal magnet type and its indications were observed by the telescope and scale method.

When the Queen resistance box was bought, some years ago, it was accompanied by a certificate from Professor Anthony to the effect that its readings were correct to one-fiftieth of one per cent at 17.5° C. and that its temperature coefficient was $\cdot 00023$. The coils used in the present investigation have nevertheless been very carefully calibrated and the values thus found used in all the calculations, for, though many of them came quite up to the guarantee, several showed deviations somewhat larger than the probable errors of observation. The resistance of the bridge wire was determined in the following manner. Let the reading of the bridge micrometer, when balance has been obtained, with two nearly equal resistances R and R' in circuit be x , and when R and R' are interchanged x' . Then if z and z' are the corresponding readings when R has been increased by a known increment dR it is easy to prove that

$$r = \frac{dR}{(x-z) + (z'-x')}$$

where r is the resistance of a length of the wire corresponding to one division of the micrometer. About one hundred determinations of this quantity, involving various lengths and different portions of the wire, gave the mean value

$$r = \cdot 000898 \text{ ohms}$$

the greatest difference between a single observation and the mean being less than 3×10^{-6} ohms. These measurements also showed that the error of a single setting of the micrometer was about one-tenth of one division and hence that the mean error of a single determination of a resistance, due to this cause alone, was less than $\cdot 0001$ ohms. Throughout the entire

investigation the resistances in the various arms of the bridge were so proportioned as to give a maximum of sensitiveness, and a movement of the spring contact on the wire equal to one-tenth of a division was always sufficient to reverse the direction of the galvanometer deflection when balance was obtained. During the measurements at 9° C. no difficulty was experienced from thermoelectro-motive forces, since the water cooler was long enough to keep all the joints at the same temperature, but when the steam jacket was employed they caused so much trouble that it became necessary to replace the copper connections inside of the piezometer by iron wires. Disturbances of this nature were thus reduced to a minimum and trustworthy results could be obtained by closing first the galvanometer and then the battery circuit. The temperature of the room and of the standard resistances, determined by a small mercurial thermometer placed between the coils, remained nearly constant during the actual time of observation but varied considerably from day to day.

If R represents the resistance of the mercury thread and W that of the standard of comparison and if x and x' are the readings of the bridge-wire micrometer for the position of balance before and after they are interchanged, we have

$$R = W + r(x - x')$$

where r has the meaning and value assigned to it above and all the connection resistances are eliminated except those between R and W and the commutator. To determine these the mercury tube was replaced by a thick copper wire soldered to the same connecting wires and measurements were then made under as nearly as possible the same conditions of pressure and temperature that were used with the mercury. The mean of a large number of observations gave .0632 ohms with the copper connections used at low temperature and .5095 ohms with the iron ones used at the boiling point, and no variation with the pressure could be detected. In reducing the resistances to the standard temperature of the Queen box the bridge wire was assumed to have the same temperature coefficient and to be always at the same temperature as the standard coils. This assumption could introduce no appreciable error in the results, since the factor $r(x - x')$ was always less than 0.1 ohm and the temperature of the room never varied much from that of the box, but it greatly simplified the calculation of the corrections. It was further found that the slight variations in the temperature of the mercury thread, from 9° C. in one case and from 100° C. in the other, introduced errors that could not be neglected and corrections were introduced using .0009 as the temperature coefficient of mercury. Finally the effect of changes in the volume of the glass tube, due to compression,

6 *Palmer—Pressure Coefficient of Mercury Resistance.*

were eliminated on the assumption that the coefficient of cubical compressibility of the glass used was $\cdot 0000025$. Calculations were instituted to determine the effect on the measurements of the slight changes in pressure, and hence in the resistances of the mercury thread, due to leakage of the compressor and gauge between the direct and reverse settings of the bridge wire contact, and it was found that the errors so introduced were generally so small and their calculation so uncertain that no appreciable benefit could be obtained by attempting their correction.

TABLE I.

| P | R | R' | R-R' | P | R | R' | R-R' |
|------|--------|--------|-------|------|--------|--------|-------|
| 1 | 12·470 | 12·451 | ·019 | 1199 | 11·963 | 11·956 | ·007 |
| 57 | 12·414 | 12·428 | —·014 | 1400 | 11·871 | 11·872 | —·001 |
| 149 | 12·382 | 12·390 | —·008 | 1651 | 11·749 | 11·768 | —·019 |
| 241 | 12·344 | 12·352 | —·008 | 1890 | 11·678 | 11·669 | ·009 |
| 301 | 12·308 | 12·327 | —·019 | 1984 | 11·637 | 11·630 | ·007 |
| 386 | 12·294 | 12·292 | ·002 | 113 | 12·406 | 12·405 | ·001 |
| 459 | 12·265 | 12·262 | ·003 | 186 | 12·374 | 12·375 | —·001 |
| 515 | 12·250 | 12·239 | ·011 | 282 | 12·333 | 12·335 | —·002 |
| 544 | 12·228 | 12·227 | ·001 | 378 | 12·302 | 12·295 | ·007 |
| 581 | 12·205 | 12·211 | —·006 | 461 | 12·255 | 12·261 | —·006 |
| 1 | 12·456 | 12·451 | ·005 | 537 | 12·236 | 12·230 | ·006 |
| 1 | 12·452 | 12·451 | ·001 | 623 | 12·195 | 12·194 | ·001 |
| 375 | 12·261 | 12·297 | —·036 | 692 | 12·168 | 12·165 | ·003 |
| 552 | 12·215 | 12·225 | —·010 | 777 | 12·142 | 12·130 | ·012 |
| 581 | 12·216 | 12·211 | ·005 | 867 | 12·071 | 12·100 | —·029 |
| 605 | 12·200 | 12·201 | —·001 | 133 | 12·396 | 12·396 | ·000 |
| 649 | 12·192 | 12·183 | ·009 | 881 | 12·105 | 12·087 | ·018 |
| 729 | 12·163 | 12·150 | ·013 | 918 | 12·094 | 12·072 | ·022 |
| 1441 | 11·837 | 11·855 | —·018 | 990 | 12·050 | 12·042 | ·008 |
| 1504 | 11·809 | 11·829 | —·020 | 1045 | 12·035 | 12·019 | ·016 |
| 1574 | 11·785 | 11·800 | —·015 | 1173 | 11·976 | 11·966 | ·010 |
| 1619 | 11·765 | 11·782 | —·017 | 1230 | 11·942 | 11·943 | —·001 |
| 1686 | 11·740 | 11·754 | —·014 | 1297 | 11·919 | 11·915 | ·004 |
| 1755 | 11·719 | 11·725 | —·006 | 1369 | 11·878 | 11·885 | —·007 |
| 1831 | 11·702 | 11·694 | ·008 | 1425 | 11·858 | 11·862 | —·004 |
| 1923 | 11·666 | 11·656 | ·010 | 1479 | 11·838 | 11·839 | —·001 |
| 177 | 12·378 | 12·378 | ·000 | 1542 | 11·815 | 11·812 | ·003 |
| 359 | 12·306 | 12·303 | ·003 | 1571 | 11·828 | 11·801 | ·027 |
| 532 | 12·230 | 12·231 | —·001 | 154 | 12·388 | 12·388 | ·000 |
| 684 | 12·180 | 12·169 | ·011 | 154 | 12·388 | 12·388 | ·000 |
| 851 | 12·116 | 12·100 | ·016 | 106 | 12·406 | 12·408 | —·002 |
| 1047 | 12·020 | 12·018 | ·002 | 106 | 12·403 | 12·408 | —·005 |

Five or ten minutes were always allowed to elapse after each increment to the pressure before the resistance measurements

were made in order that the irregularities in temperature, due to compression, might become equalized and the distribution of pressure throughout the whole apparatus become uniform. It was also possible by this method to determine whether the rate of leakage was sufficient to seriously affect the results and when this was found to be the case to adopt means to prevent it. The observations at 9° C. are given, in the order in which they were taken, in table I, and those at 100° C. in table II, where the columns P and R contain respectively the pressure in atmospheres and the corresponding corrected resistances in ohms. The chart, fig. 1, shows the same data graphically, the horizontal scale being one hundred atmospheres and the vertical one-tenth ohm per division. The base line corresponds to 11.6 ohms and the temperature at which each series was made is marked above it.

TABLE II.

| P | R | R' | R-R' | P | R | R' | R-R' |
|------|--------|--------|-------|------|--------|--------|-------|
| 88 | 13.388 | 13.360 | .028 | 1521 | 12.711 | 12.714 | -.003 |
| 161 | 13.348 | 13.327 | .021 | 1600 | 12.685 | 12.678 | .007 |
| 239 | 13.310 | 13.292 | .018 | 1690 | 12.644 | 12.638 | .006 |
| 325 | 13.257 | 13.253 | .004 | 1788 | 12.603 | 12.594 | .009 |
| 407 | 13.227 | 13.216 | .011 | 1895 | 12.573 | 12.545 | .028 |
| 471 | 13.204 | 13.188 | .016 | 1969 | 12.518 | 12.512 | .006 |
| 531 | 13.177 | 13.160 | .017 | 2139 | 12.459 | 12.435 | .024 |
| 572 | 13.156 | 13.142 | .014 | 2214 | 12.430 | 12.401 | .029 |
| 647 | 13.125 | 13.108 | .017 | 59 | 13.378 | 13.373 | .005 |
| 697 | 13.103 | 13.086 | .017 | 210 | 13.299 | 13.305 | -.006 |
| 739 | 13.069 | 13.067 | .002 | 316 | 13.246 | 13.257 | -.011 |
| 801 | 13.030 | 13.039 | -.009 | 420 | 13.207 | 13.211 | -.004 |
| 862 | 13.014 | 13.011 | .003 | 513 | 13.148 | 13.168 | -.020 |
| 904 | 12.982 | 12.992 | -.010 | 596 | 13.114 | 13.131 | -.017 |
| 947 | 12.974 | 12.973 | .001 | 713 | 13.047 | 13.078 | -.031 |
| 1008 | 12.931 | 12.945 | -.014 | 834 | 13.004 | 13.024 | -.020 |
| 1053 | 12.920 | 12.925 | -.005 | 955 | 12.939 | 12.969 | -.030 |
| 1156 | 12.865 | 12.878 | -.013 | 1067 | 12.898 | 12.919 | -.021 |
| 1235 | 12.830 | 12.843 | -.013 | 1199 | 12.845 | 12.859 | -.014 |
| 1293 | 12.824 | 12.817 | .007 | 1324 | 12.800 | 12.803 | -.003 |
| 1306 | 12.797 | 12.811 | -.014 | 1441 | 12.721 | 12.750 | -.029 |
| 1400 | 12.762 | 12.768 | -.006 | 1599 | 12.684 | 12.679 | .005 |
| 1468 | 12.743 | 12.738 | .005 | 1741 | 12.616 | 12.615 | .001 |
| 1509 | 12.724 | 12.719 | .005 | 1877 | 12.574 | 12.553 | .021 |
| 1580 | 12.693 | 12.687 | .006 | 2029 | 12.476 | 12.485 | -.009 |
| 1652 | 12.668 | 12.655 | .013 | 2113 | 12.481 | 12.447 | .034 |
| 1705 | 12.647 | 12.631 | .016 | 2236 | 12.339 | 12.392 | -.053 |
| 1719 | 12.625 | 12.625 | .000 | 1838 | 12.567 | 12.571 | -.004 |
| 9 | 13.394 | 13.396 | -.002 | 1409 | 12.746 | 12.764 | -.018 |
| 1292 | 12.834 | 12.817 | .017 | 1023 | 12.908 | 12.938 | -.030 |
| 1368 | 12.763 | 12.783 | -.020 | 587 | 13.107 | 13.135 | -.028 |
| 1452 | 12.733 | 12.745 | -.012 | 103 | 13.401 | 13.354 | .047 |

8 *Palmer—Pressure Coefficient of Mercury Resistance.*

Combining these observations by the method of "Least Squares" we have

$$\begin{array}{l} \text{at } 9^{\circ} \text{ C.} \quad R = 12.4518 - .000414P \\ \text{at } 100^{\circ} \text{ C.} \quad R = 13.3999 - .000451P \end{array}$$

The lines on the chart have been drawn in accordance with these equations, and it will be seen that the plotted points are very nearly in coincidence with them. The values of R computed by these formulæ have been entered in the tables under R' and the relative errors, from which the probable error of a single observation has been found to be .008 ohms at 9° C. and .012 ohms at 100° C., under $R - R'$. Hence the resistance measurements are accurate to less than one-tenth of one per cent and are as good as could be expected when it is remembered that the uncertainty in determining the pressure is about the same in magnitude and that it is impossible to entirely prevent leakage when very high pressures are employed. Furthermore small errors were probably introduced by the lag in the indications of the mercurial thermometers behind the actual temperature variations. Putting the above equations in the form

$$R = R_0(1 + \beta P)$$

where β is the increment to unit resistance caused by one atmosphere increase in pressure, we have, after calculating the probable error in the usual way from the sum of the squares of the errors,

$$\begin{array}{l} \text{at } 9^{\circ} \text{ C.} \quad \beta = -.00003324 \pm .00000014 \\ \text{at } 100^{\circ} \text{ C.} \quad \beta = -.00003367 \pm .00000019 \end{array}$$

Hence it follows at once that at any temperature

$$\beta = -.0000332 - 5 \times 10^{-9} t$$

where the last term, owing to its extremesmallness, is probably only approximately accurate.

The difference between this result and that of Barus ($-.00003$) is so small that it can be easily accounted for by the slight impurities in the commercial mercury used by him. Lenz's original paper is unfortunately inaccessible and the account of it in the *Beiblätter* is meager. He used a tube 1.2 meters long filled at atmospheric pressure, and it is probable that the very large coefficient ($-.0002$) obtained was due to the imperfect removal of air bubbles from its inside walls, a source of error having its maximum effect at the low pressures employed by him.

The two series of observations marked by circles on the chart, fig. 1, are so obviously affected by consistent errors that they have been left out of the calculations. The first was

obtained after the apparatus had been left sustaining a pressure of about 750 atmospheres for two hours and lies below the line, while the second, obtained after rapidly increasing the pressure from one to 1640 atmospheres, lies above it. Similar

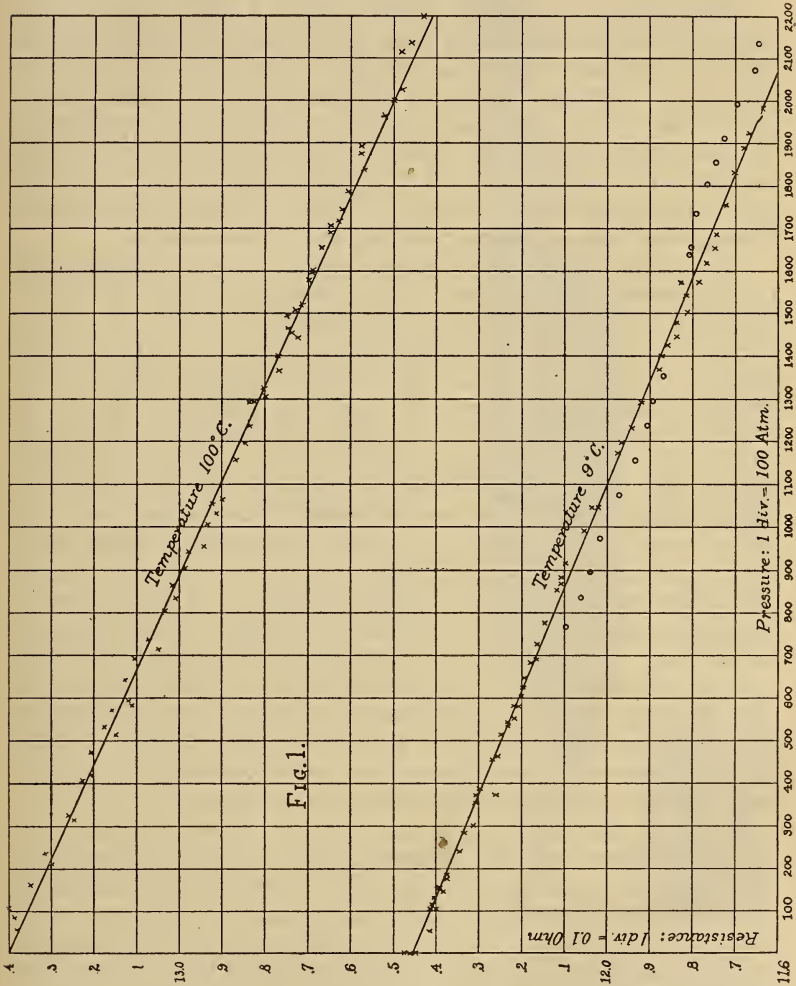

operations at another time failed to produce similar results and an entirely satisfactory explanation does not present itself, but it is probable that the first is due largely to imperfect freedom of the gauge pistons, caused by particles of dirt in the oil leaking past them, and the second to the heat produced by rapid compression.

Brown University, March 18, 1897.

ART. II.—*On Otenacanthus Spines from the Keokuk Limestone of Iowa*; by C. R. EASTMAN.

THROUGH the courtesy of Mr. Lisban A. Cox, of Keokuk, Iowa, the writer has recently been able to study certain Selachian remains obtained from the so called "lower fish-bed" in the vicinity of Keokuk, and now preserved in the private collection of Mr. Cox. Two very perfect fin-spines were considered by this gentleman to be new, as they differed from anything he had ever observed from this horizon or elsewhere during his long experience as a collector. It will be seen from the following that he was largely justified in his conclusions.

The larger of the two ichthyodorulites belongs undoubtedly to the genus *Otenacanthus*. It preserves a length of 20.5^{cm}, and is 2.6^{cm} in maximum width; possibly 1.5 or 2^{cm} are wanting from the distal extremity, but the base is entire. It is gently arcuate in form, the anterior margin being more strongly and regularly convex than the posterior; and it is laterally much compressed. Its general shape and proportions agree with those of a unique spine from the same horizon, upon which St. John and Worthen* founded the species *Acondylacanthus? xiphias*, the chief difference consisting in the ornamentation. But these authors are careful to state that their specimen was much abraded, and it was referred to *Acondylacanthus* with considerable hesitancy on that account. Although admitting that if found to possess nodose costæ it would have to be transferred elsewhere, they concluded that "in the absence of any such ornamentation and the apparent smooth plain costæ, its affinities are clearly with the above genus [*Acondylacanthus*]." They also point out that "the typical forms of *Acondylacanthus* are more slender and proportionately narrower, than the above described form."

There seems to be every reason for believing that the type of *A. ? xiphias* and the specimen now under consideration represent two examples of the same species, the differences between them being only such as are due to different conditions of preservation. In this event the name must be changed to *Otenacanthus xiphias*, and the specific definition will require emendation, so as to include characters not observed on the original specimen.

As may be seen from the accompanying figure, there is no species with which these Keokuk spines are so closely related as *C. denticulatus* M'Coy, from the Lower Carboniferous of England and Ireland. There is a remarkable resemblance to

* Palæontology of Illinois, vol. VII, p. 244, pl. xxvi, fig. 1.

this form, both in size, shape, and details of ornamentation. The longitudinal costæ are of round cross-section, about the same distance apart, and are denticulated or collared in the same manner in both forms. In *C. xiphias*, however, they arise less frequently by dichotomy, and as far as can be learned from the present specimen, the series of denticles on the posterior face is nearly obsolete. Only the bases of these denticles are preserved on the specimen, but they are quite faint, and appear to be limited to the distal half of the spine. The exerted portion is very obliquely demarcated from the base, and the pulp-cavity remains open for quite a distance beyond it. No evidence of a keel appears on either face, but along the anterior margin two longitudinal costæ, arising one on either side, unite to form a blunt ridge serving as a cutwater. The inserted portion tapers more gradually than in *C. denticulatus* and most other species. A knowledge of these characters enables us to frame a more complete diagnosis of this species, as follows :

Ctenacanthus xiphias (St. John and Worthen).

Spines attaining a length of over 20^{cm}, moderately curved, the anterior margin more strongly convex than the posterior; gradually tapering, and laterally very much compressed. Base deeply embedded, tapering, and obliquely marked off from the exerted portion; pulp cavity continued in a posterior channel for about half the total length of the spine. Denticles of posterior angles uniformly spaced, more or less rudimentary. Ornamentation consisting of parallel longitudinal ridges, rarely bifurcating or implanted, rounded, about their own diameter

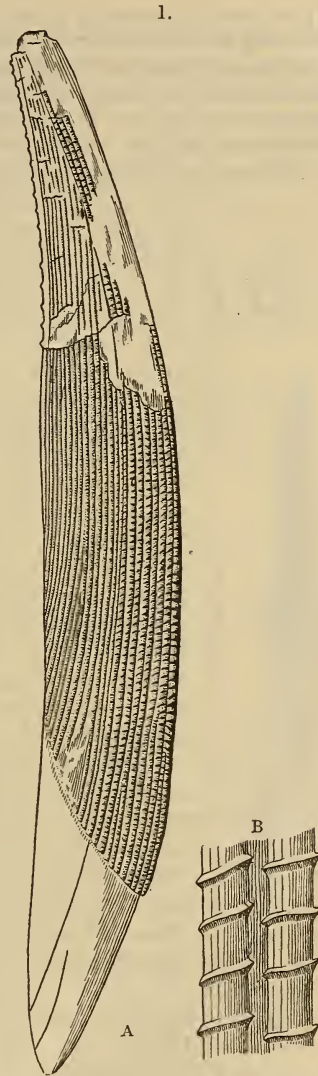

J.W.F.

FIG. 1.—*Ctenacanthus xiphias* (St. John and Worthen). A, Spine $\frac{2}{3}$ natural size. B, Ornamentation 4 times enlarged.

apart, and decreasing in size toward the posterior face. Each of the costæ is denticulated by numerous sharp folds, which extend half way across the intercostal spaces, and are separated from each other by about the thickness of the ridge. The anterior edge of the spine is formed by a ridge wider than the rest, and of compound origin.

The second ichtthyodorulite that deserves notice represents a new species of *Otenacanthus*. It will be seen from the



FIG. 2.—*Otenacanthus acutus* sp. nov. A, Spine $\frac{2}{3}$ natural size. B, Cross-section of same.

J.W.F.

annexed illustration that the spine is very nearly perfect, only the extreme tip being broken away. It is 12.5^{cm} long, and not quite 1.5^{cm} in maximum width. Its stylet-shaped form, nearly rectilinear edges, and the nature of its ornamentation readily distinguish it from all other species. In cross-section it is less compressed than most spines belonging to *Otenacanthus*. The posterior face is embedded in the matrix, but the latter has been removed along one edge sufficiently to reveal a series of small denticles standing at right angles to the axis of the spine. A convenient fracture makes it possible to remove the base, thus displaying the pulp-cavity at that point. It is of ample size, and is continued for a short distance upward in an open groove as in other species. Another fracture higher up presents the cross section shown in fig. 2B, from which it will be seen that a posterior keel is present.

Owing to abrasion, the longitudinal costæ appear nearly smooth except along the posterior edges, where they retain their tuberculation. The tubercles are quite small, and resemble those of *C. keokuk*; a few are also distributed in the intercostal grooves, thus indicating an approach to *Asteroptychius*. Besides bearing tubercles, the costæ appear to have been denticulated along their sides, as indicated by transverse markings in many of the intercostal spaces. The ridges are triangular in cross-section, increase in number downward by dichotomy, and are much crowded towards the posterior face; some of them appear longitudinally striated when worn. The anterior margin of the spine is formed by the confluence of several ridges, and becomes thickened in consequence.

The definition of this species may be summarized briefly as follows:

Ctenacanthus acutus sp. nov.

Medium sized spines with margins of the exerted portion almost perfectly straight, tapering gradually toward the apex; base deeply embedded; posterior angles closely set with a row of small denticles arising perpendicularly. Longitudinal costæ numerous, triangular in section, bearing minute tubercles on their summits, and denticulated along the sides; increasing by bifurcation. Posterior face with a median longitudinal keel.

Including the two species described above, the Keokuk limestone is known to yield six representatives of *Ctenacanthus*, and in all ten "genera" of ichthyodorulites. Some of the latter, however, are unsatisfactorily determined. Following is a list of the *Ctenacanthus* species:

| | |
|----------------------------------|-----------------------------------|
| <i>C. acutus</i> Eastman. | <i>C. excavatus</i> St. J. and W. |
| <i>C. coxianus</i> St. J. and W. | <i>C. keokuk</i> St. J. and W. |
| <i>C. cylindricus</i> Newberry. | <i>C. xiphias</i> (St. J. and W.) |

Museum of Comparative Zoology,
Cambridge, Mass.

ART. III.—*Studies in the Cyperaceæ*; by THEO. HOLM.
V. *Fuirena squarrosa* Michx. and *F. scirpoidea* Vahl. With
19 Figures (pp. 25, 26).

THESE two species are natives of the eastern United States, *F. squarrosa* showing a distribution from Massachusetts as far south as subtropical Florida, while the other species is confined to Georgia and Florida alone. It is a marked characteristic of the genus that a true perianth is developed, in our species represented by six leaves in two alternating whorls, those of the inner being spathulate, while the others are merely bristle-shaped like those of *Dulichium*, *Rhynchospora*, etc.; this, the outer, whorl of the perianth is, however, undeveloped in several of the foreign species of *Fuirena*, as well as in *F. umbellata*, upon which Rottböll established the genus, first discovered in Surinam by Rolander, who described it as "*Scirpus tripetalos*." The genus is closely related to *Scirpus*, with which it, also, shows a great resemblance in regard to the general habit, but is well distinguished by the spathulate shape of the perianth as also by the hairy bracts of the flowers, which are smooth in the species of *Scirpus*. When compared with each other, our two *Fuirena*-species show several external characters, by which they are readily distinguished, viz: the reduction of the stem-leaves in *F. scirpoidea* to sheaths with a minute blade, while *F. squarrosa* has well-developed leaf-blades. The bracts of

the flowers are broad and very short-pointed in *F. scirpoidea* (fig. 13), but rather narrow and long-awned in the other species (fig. 11). The inflorescence is a spike, there being one terminal and several lateral, often situated close together or scattered on long peduncles from the axils of the stem-leaves as in *F. squarrosa*. A clado-prophyllon is present and is short, very broad and distinctly bidentate in *F. scirpoidea* (fig. 12), while it varies from oblong, slightly emarginate to long and tubular in *F. squarrosa* (figs. 6 and 10), in accordance with its place on the very short rhachis of the lateral spike or at the base of the long peduncles, which bear several spikes at the apex, and which are commonly developed in the axils of some of the lower stem-leaves in *F. squarrosa*.

Another character is to be observed in the shape of the inner perianth-leaves, which, although they are spatulate in both species, are almost obtuse in *F. scirpoidea*, but vary from short-pointed to long-awned in the other species; a similar variation in regard to the respective length may, also, be noticed in the bristles. The rhizome of our species shows a very considerable difference, being stout and extensively creeping in *F. scirpoidea* in contrast to that of *F. squarrosa*, which is almost cæspitose with ascending, not creeping, shoots and which, also, possesses some tuberous organs, each of which represents a single internode.

We see from these divergencies that our two *Fuirena*-species do not lack morphological characters; all of which are of specific value, and we shall show, later on, in this article that their internal structure is no less important for their specific distinction. We must, however, not neglect to consider our plants also from a biological point of view; and we shall try to demonstrate, at least, a part of their life-history, based upon our investigations and compared with the more important studies of similar kind, which we have met with in our literary research. There are, for instance, in regard to the germination of *Fuirena* a few points of interest, which deserve notice, although they are not new; nevertheless, when we discuss them, it is merely on account of the very defective knowledge we have of the seedlings of this group of plants, the *Cyperaceæ*, and we thought, also, that a brief historical sketch of this early stage of their life-history might be of some interest to the reader.

The principal difference, that exists between the germination of the *Cyperaceæ* and the *Gramineæ*, consists in the fact that in the *Cyperaceæ* the plumule is the first to push out through the caryopsis, while in the *Gramineæ* the primary root is the first to appear. In *Fuirena* as in the other *Cyperaceæ*, which so far have been examined, the plumule is covered

by a membranous sheath at the base of which a small, roundish wart soon becomes visible, and which represents the primary root. The cotyledon, on the contrary, stays inside the seed, its function being to absorb the endosperm. These are the general features of the germination, and it may, at first glance, seem to be a very easy matter to define these various organs, which as we have shown constitute the seedling. We may, by considering our figure 1*b*, define the conical body (C) as representing the cotyledon and as being identical with the scutellum of the *Gramineæ*; we may define the sheathing leaf (*Sh*) as the second leaf, and L' as the first developed green leaf. The primary root (R) is already relatively long and covered with root-hairs. By comparing now this figure (1*b*) with our figure 1, we notice the same organs, besides a stem-part (*j*) which separates the cotyledon (C) from the sheathing leaf (*Sh*); a secondary root (*r*) has developed from this stem-part, and another one (*r'*), but much younger, has started to break out through the base of the sheathing leaf (*Sh*). One should, according to these figures, never doubt the morphological identity of these organs, as we have defined them above, especially when we point out the long internode (*j*) which lies between the cotyledon (C) and the sheathing leaf (*Sh*), viz: that these organs should not be independent of each other. It seems, nevertheless, to be a most difficult task to define them correctly, so as to bring them in strict conformity with the corresponding organs in the other monocotyledonous plants, and at the same time avoid bringing their anatomical structure in contest with their rank in a morphological respect. If we, for instance, consider the body at C as the cotyledon, its structure must correspond with that of a leaf, and if we, also, define the sheathing organ at *Sh* as a leaf, this must not be in any connection with the other one at C; furthermore, if the stem-part (*j*) is really an internode, it must show a structure in conformity herewith. The difficulty is, however, that these organs do not exactly show the anatomical structure as they "ought," according to our idea, and even if a morphological consideration may seem more natural, we cannot feel justified in overlooking the structural characters. We will, therefore, in our attempt to explain this matter, strive to establish a conformity, so that the morphological peculiarities may be brought in accordance with the anatomical ones, and we believe this may be attained by presuming that some modification exists in the development of some of these organs. A literary research upon this question is exceedingly instructive, and there are, indeed, few stages in the plant life that have required so many and such able investigations in order to become understood, as has the germination of the *Gramineæ* and the *Cyperaceæ*.

The *Gramineæ* seem, however, to have attracted a good deal more attention than the *Cyperaceæ*, although their seedlings agree in most respects. It is, now, interesting to see from the literature how many and very diverse opinions have been expressed by the morphologists in order to define the organs of these seedlings; and even if so eminent an anatomist as Van Tieghem has tried to pacify the contesting parties by submitting a most excellent and detailed account of the internal structure of these germinating plantlets, it seems, nevertheless, that the morphological standpoint taken by Warming, in adherence to the views expressed by Poiteau, Mirbel and Turpin, may prove satisfactory to all concerned.

The most important difference between the seedlings of these two families consists in the presence of a very small organ like a rudimentary leaf, which in some *Gramineæ*, but not in all, is to be observed on the anterior face of the seedling, and in alternation with the so-called scutellum. This scale-like appendage had been observed and figured by Malpighi as far back as the year 1675, and it has since that time been repeatedly described and given a number of names, the best known among these being the "lobule" of Mirbel, and the "épiblaste" of Richard. While Poiteau, Mirbel and Turpin considered this organ as an independent leaf or even as a "second, but small cotyledon," the majority of the other authors have only understood it as a part of the cotyledon. It is strange, that the most modern and generally adopted idea is now that of Gärtner (l. c.), who more than a hundred years ago defined the scutellum as the median part of the cotyledon, the épiblaste or lobule as an appendix to this, while the sheathing leaf (*Sh*) should represent the ascending sheath of the cotyledon, thus these three organs should all constitute the cotyledon, and the first green leaf (*L'*) should then be the first leaf of the plant next to the cotyledon. This rudimentary organ, the épiblaste, is not known to exist in the *Cyperaceæ*, and we have therefore great difficulty in finding proofs for our explanation, according to which the cotyledon and the sheathing leaf should represent organs, independent of each other. It will be seen from our drawings (figs. 1 and 1*b*) that the sheathing leaf (*Sh*) is situated just above and at the same side of the axis as the cotyledon (*C*), indicating a leaf arrangement as "uniseriate" which would be too unnatural to be acceptable. But when we compare our *Fuirena*-seedlings with similar ones of *Gramineæ* "with or without the épiblaste," the suggestion arises that this little organ has been suppressed in the *Cyperaceæ*, as in a number of the *Gramineæ*. Seedlings of grasses with a developed épiblaste show the same biseriata arrangement of the leaves as we find later on in the mature

plants, counting the cotyledon as the first, the épiblaste as the second and the sheathing leaf as the third leaf of the young plant. We might be allowed to suggest that the épiblaste has become undeveloped in the *Cyperaceæ*, but without influencing or rather without disturbing the normal arrangement of the leaves, as we find them in *Fuirena* and all the others examined. It was the frequent development of a stem-part between the cotyledon and the sheathing leaf, which led Warming to adopt the explanation of these three organs, including the épiblaste, as independent; but, strange to say, Warming does not in his paper upon this subject (l. c.) enter into any discussion as to the severe objections raised by Van Tieghem against this theory. Van Tieghem denounces the épiblaste as a leaf, because it does not receive any mestome-bundles from the axis; the sheathing leaf will, therefore, necessarily be situated above and "at the same side" as the scutellum, and can consequently not be independent of this. He, finally, demonstrates that the supposed internode (*j*) is only a node according to its anatomical structure, but a node, which has become unusually stretched, so that the cotyledon and the sheath have become somewhat separated from each other. These very serious objections are, of course, a heavy blow to the theory regarding the existence of three independent leaves, an explanation which otherwise seems so very natural and in good conformity with the rules of morphology. We venture, however, to suggest that the épiblaste may be a leaf-primordium and that it stays as such with no mestome-bundles developed, and as a leaf, which is often suppressed entirely. We will, also, state that we cannot find any decided objection in considering the cotyledon as a leaf, independent of the épiblaste and of the sheathing leaf, even if, as Van Tieghem has proved, the stem-part is only a node. There is among the numerous and most important agrostologic papers by Duval-Jouve one (l. c.) in which he describes the nodes of *Eleusine*, *Cynodon* and other *Gramineæ* as bearing more than "one leaf," from one to two or even three! This same fact is very familiar to us, when we remember the peculiar, dense-leaved nodes of *Diplachne*, *Munroa*, *Buchloë* and several other North-American grasses. We might also state, that it is not quite certain that the épiblaste is constantly present only as a rudimentary organ, since Didrichsen (l. c.) has figured this organ taken from *Avena sativa*, where it shows a distinct nervation, corresponding to a very finely-lobed margin. We believe, however, that a continued research will throw a clearer light upon this subject, and there is no doubt that seedlings of our native grasses and sedges will show some facts that may be helpful for the explanation of this remarkable manner of germinating. We will,

also, at this place, call attention to a work by Klebs (l. c.), wherein is given a summary of the different manners of germination, considered from a morphological as well as from a physiological point of view, besides that this author has enumerated the most prominent works upon the subject, which, of course, is a most valuable guide for literary research.

Having discussed now the germination of our plants, let us examine them at a later stage, when their vegetative organs are fully developed; and we may begin with the rhizome. We have already mentioned above, that the rhizome of our two species shows a very marked difference in external structure, although their manner of ramification is exactly the same in both species. We find here a true sympodium, and the difference lies merely in the tuberous development of some internodes in *F. squarrosa*. While the sympodial ramification is very common in the Phanerogames, especially in their rhizomes, there are, nevertheless, only a few which exhibit the sympodium so plain as our *Fuirena scirpoidea*. Figure 7 illustrates the anterior part of a rhizome of this species, and we have, also, redrawn the apex of the same, but on a larger scale in order to represent the exact position of each organ (fig. 8). The rhizome is horizontally creeping and consists of distinct internodes with scale-like leaves. At certain intervals, in our species, between each two leaves, a flower-bearing stem arises, while an axillary bud develops at the same time, continuing the growth of the rhizome in the same direction, as if it was the terminal bud. By comparing figs. 7 and 8, we notice the scale-like leaf B, which is borne on the main axis (ax^1) and which at the same time supports another, but secondary axis (ax^2), which is readily seen to be axillary. These two axes (ax^1 and ax^2) have fused together and form partly a single internode, but there is a somewhat depressed line to be seen where the fusion has taken place, and the axillary branch is, always, well-marked by having its first leaf developed as a bicarinate prophyllon (pr in fig. 8) with its characteristic position in regard to the main-axis. The rhizome of *F. scirpoidea* does not branch much to the sides, but when such branches develop, they always originate from the axil of the lowest situated leaf of a flowering stem (fig. 9), while we have not observed any to be developed from the scale-like leaves, excepting from the apex of the rhizome, as described above.

The same sympodial ramification is, also, to be found in the other species, *F. squarrosa*, some parts of the rhizome of which are illustrated in figures 2 and 4, in addition to some diagrammatical drawings in figs. 3 and 5 of the same parts. Figure 3 shows, for instance, the apex of an old rhizome (fig. 2) where B is a scale-like leaf from the main stem, the continuation of

which (ax^1) attains a peculiar tuberous development of the internode above the leaf (b). Another shoot pushes out from the axil of the scale-like leaf B, which is, consequently, of second order (ax^2), and which develops into a leaf-bearing shoot of normal structure. We find this same manner of development if we consider figure 5, which represents an enlarged portion of the rhizome (fig. 4). We see, also, here the two systems of axes (ax^1 and ax^2) one of which (ax^1) shows the same tuberous internode (i^2) as described above. The axillary shoot (ax^2) bears here two scale-like leaves (b^1 and b^2), of which the upper one (b^2) supports the shoot, ax^2 , well distinguished as axillary by its prophyllon (pr). This figure shows, then, the development of the axis of first order either as a flower-bearing stem with stretched internodes, or as a tuberous shoot with the growing-point arrested in its further development; the axis of second order seems, also, in this species to stay underground as purely vegetative. In regard to the tuberous development of one of the internodes of *F. squarrosa*, we must state, that this seems to be a very rare case in the *Cyperaceæ*, while tubers of several internodes are known from a few species of *Cyperus*, e. g. *C. esculentus* and *C. phymatodes*, which have been described in a very clear and comprehensive manner by Seignette (l. c.) In the *Gramineæ*, on the contrary, such single tuberous internodes are not very rare, and Hackel (l. c.) enumerates quite a number of grasses, representing a development like that of *Fuirena squarrosa*. These grasses are mostly inhabitants of regions of which a periodical drought is characteristic, and Hackel mentions for instance the Pacific species of *Melica*, some Mexican species of *Panicum*, the genus *Ehrharta* from the Cape Colony, besides several species from the Mediterranean.

In regard to the stem above-ground, this is in *F. scirpoidea* built up of a number of rather short internodes, of which all the leaves are merely present as sheaths, the blade being only a rudiment; the stem of the other species is of usual form, but none of the internodes is, however, long enough to be defined as a scape. The leaves of *F. squarrosa* have long, linear blades, like the tubular sheath very hairy; a ligule is, also, developed as usual in the long-leaved *Cyperaceæ*, and it is very strange that this organ seems almost constantly to have been overlooked in this family, although it is very distinct, when developed. Baillon (l. c.) and Bentham and Hooker have even considered the ligule as one of the generic characters of *Fuirena*, viz: "foliorum vagina ligula coronata." It is, on the other hand, just as incorrect when the authors of botanical manuals constantly attribute this same organ, the ligule, to all the *Gramineæ* without exception, although it is absent in

many, e. g., all the broad-leaved species of *Panicum*, viz: *P. microcarpon*, *viscidum*, *clandestinum*, etc. We have already described the structure of the inflorescence and of the single flowers, and having not observed any other characters of morphological interest, we will proceed to the anatomical part of our paper.

The rhizome.

This shows a very firm structure in *F. scirpoidea*, since the bark-parenchyma contains a concentric ring of small groups of very thick-walled stereome, besides that a closed ring of several layers of this same tissue, the stereome, surrounds the central-cylinder. The mestome-bundles seem to be all collateral, and are supported by stereome on their hadrome-side; they are not arranged in any order, but scattered in the large mass of fundamental tissue. We mentioned in our previous article upon *Dulichium* the presence of tannin-reservoirs, which we have noticed again in both species of *Fuirena*. These reservoirs are quite numerous in the rhizome, especially in the outer layers of the bark-parenchyma.

By examining the rhizome of *F. squarrosa*, the internodes of normal thickness showed a large quantity of starch deposited in the bark and in the fundamental tissue, which occupies the greater part of the central-cylinder. Immediately inside the epidermis some small groups of stereome are to be observed, and this tissue appears again in about three or four strata, forming a closed ring inside the bark, and surrounding the central-cylinder. A thin-walled endodermis is very distinct, and the collateral mestome-bundles are arranged very regularly in three alternating bands, with their hadrome-side supported by thin-walled stereome; similar, but smaller, mestome-bundles were, also, observed in the bark. Tannin-reservoirs were observed to be quite numerous and of large size in the bark.

If we now compare this structure with that of a tuberous internode, we notice the almost complete disappearance of the stereome, and also that there is here only one single band of collateral mestome-bundles, located a very short distance from the epidermis. The fundamental tissue occupies the greatest part of the internode and is filled with starch. It appears from this, that the function of these thickened internodes is for the storage of nutritive matters; in the *Gramineæ*, however, their function is different, according to Hackel's observations, who states that he was unable to find any deposits of starch in their swollen internodes, although these were examined at different seasons of the year. He, therefore, concludes that they may represent a kind of water-

reservoirs, which might be of some use to these plants in the dry seasons. A different view has, meanwhile, been expressed by Seignette, who (l. c. p. 39) describes the structure of *Avena elatior* var. *bulbosa* (*A. bulbosa* Willd.), and who found a large quantity of starch deposited in the fundamental tissue.

The stem above-ground.

It is cylindric, but furrowed in *F. scirpoidea*, and, as already stated, consists of numerous internodes. The epidermis-cells are relatively small, perfectly smooth, and stomata are, of course, well represented in this tissue. The bark-parenchyma shows a very characteristic palissade-tissue of several layers, and is interrupted by large groups of stereome. The inner part of the bark passes gradually over into a colorless tissue, which occupies the interior part of the stem; the mestome-bundles are arranged in a band and are to be observed in the green bark, just inside the groups of stereome, which border on their colorless parenchyma-sheaths. A very few mestome-bundles are, also, noticed in the fundamental tissue, and these show a much larger lacune in the hadrome-part than is to be observed in the bundles of the outer band. The stem of *F. squarrosa* shows a somewhat different structure; it is terete, furrowed and smooth, but much weaker than that of the preceding species. The cells of epidermis are large and very thin-walled, and the green bark consists only of about seven strata, in which lacunes are to be observed. The mestome-bundles are arranged in two alternating bands and located in the very large, colorless-parenchyma, which occupies the central-cylinder; the bundles are supported by large groups of stereome, which reach through the green bark to the epidermis itself. Characteristic of the stem of this species is the presence of lacunes, one between each of the two mestome-bundles and several in the fundamental tissue, rendering the stem almost hollow.

The leaf

of *F. scirpoidea* has a long, tubular sheath but only a minute, rudimentary blade. A transverse section of the blade (fig. 17) is thick, but very narrow. The epidermis consists of rather large cells, but none of them are, however, developed as "bulliform," although some of the cells above the midrib are considerably larger than the others; stomata (fig. 18) are especially abundant on the inferior face of the small leaf-blade as well as on the sheath. These stomata are not prominent, but almost in niveau with the surrounding cells. The mesophyll (the black tissue in fig. 17) consists of rather closely-packed

roundish or polyëdric cells, none of which are differentiated as palissade-cells. There are only a few, about seven, mestome-bundles, of which the median one is the largest; they are all surrounded by thin-walled and colorless parenchyma-sheaths inside of which we meet with a typical mestome-sheath. The hadrome-part is rather large, and contains a number of vessels. There are groups of stereome on the leptome-side of the mestome-bundles, while this tissue is almost wanting on the hadrome-side, excepting in the median bundle. Reservoirs of tannin were noticed as being very abundant in the mesophyll. A more complete structure is shown by the long leaf-blade of *F. squarrosa* (fig. 14). Epidermis consists of very large cells on the superior face of the blade, and is developed as "bulliform-cells" above the midrib and two of the largest mestome-bundles. Hairs are abundant in this species, and are present as very short ones on the superior face of the blade, while those of the margins and the inferior face are long and sharply pointed. The stomata (fig. 15) are very prominent, and seem only to be developed on the inferior face of the blade. The mesophyll is well developed, consisting of hexagonal very closely-packed cells, while a large lacune is to be seen between each of the two mestome-bundles. These last are surrounded by colorless, thin-walled parenchyma sheaths as well as by the usual mestome-sheath, and the larger bundles are on both faces supported by some small groups of stereome.

The root

of *F. scirpoidea* agrees in most respects with that of the other *Cyperaceæ*, having a hypoderm inside the epidermis, and with the characteristic radial arrangement of the bark-cells, of which the innermost layer, as usual, is differentiated as an endodermis. This endodermis shows, however, a very peculiar development, since the cells, which are exceedingly thin-walled, are stretched radially, as shown in our figure 19. The pericambium is, also, here interrupted by protohadrome, and there are five distinct groups of leptome in alternation with five large vessels, while the innermost part of the root is occupied by fundamental tissue. The root of *F. squarrosa* shows a much weaker structure, since the bark-parenchyma shows many lacunes on account of the radial collapsing of the cell-walls. The cells of the endodermis (*End* in fig. 16) are of normal shape and slightly thickened. A large vessel occupies the center of the root, and tannin-reservoirs were observed in the epidermis as well as in the outer bark-parenchyma.

We see from this brief anatomical sketch that there are several structural characters, by which these two *Fuirena-*

species may be distinguished, although their morphological characters are so prominent as to leave the anatomical distinction unnecessary. But it is, nevertheless, quite interesting to compare their structure in order to ascertain whether there may be some connection between the structure of their tissues and the character of the climate and soil wherein they grow. *Fuirena scirpoidea* has several features in common with some of the most pronounced desert-plants, viz: the reduction of the leaf-blades in contrast to the other species of the genus. It grows in dry, sandy soil and is a very common plant in subtropical Florida. The anatomy of its almost leafless stem shows us a well differentiated palissade-tissue in the bark, thus the stem has taken the function of the leaf; the very thick-walled epidermis is another character by which *F. scirpoidea* approaches itself to the desert plants, e. g., *Panicum turgidum*, as described in Volkens' excellent work upon desert-vegetation (l. c.). We must not, however, consider our *Fuirena* as an exception from most of the *Cyperaceæ* because its leaf-blades are not developed; this very same external structure is, as we remember, very common in species of *Scirpus*, *Eleocharis* and in many *Juncaceæ*. But these almost leafless species grow always in wet soil, in marshes, etc., while our *Fuirena* prefers the dry sand, although not entering in the "Scrub" vegetation, which to a certain extent constitutes a desert-vegetation in Florida.

The anatomical characters are, otherwise, to be observed in the root, viz: the peculiar endodermis in *F. scirpoidea*, the lacunes in the bark in *F. squarrosa*, while the leaf shows us a dense hairy covering and very prominent stomata in *F. squarrosa* in contrast to *F. scirpoidea*; the stem of *F. scirpoidea* with its firm structure and the bark developed as palissade-tissue is very different from the weak stem of *F. squarrosa* with its large lacunes.

Washington, D. C., January, 1897.

Bibliography.

1. Baillon, H. Monographie des Cyperacées, Restiacées et Eriocaulacées. Paris, 1893, p. 361.
2. Didrichsen, F. Afbildninger til Oplysning af Græskimens Morphologi, edit. by Warming. Botan. Tidsskr., vol. xviii, Kjöbenhavn, 1892, p. 3.
3. Duval-Jouve, I. Sur les feuilles et les nœuds de quelques Graminées. Bull. soc. bot. de France, vol. xvi, Paris, 1869, p. 106.
4. Gärtner, I. De fructibus et seminibus plantarum, vol. i, 1788, p. 149.
5. Hackel, E. Ueber einige Eigenthümlichkeiten der Gräser trockener Klimate. Verhandl. d. k. k. zool.-bot. Ges. Wien., 1890, p. 2.

6. Klebs, Georg. Beiträge zur Morphologie und Biologie der Keimung. Untersuch. d. botan. Inst. zu Tübingen, vol. i, Leipzig, 1881–1885, p. 571.
7. Malpighi, Marc. Anatomie plantarum. London, 1675, p. 77.
8. Mirbel Brisseau, C. F. Elémens de Physiologie végétale et de Botanique, vol. i, Paris, 1815, p. 64.
9. Pax, Ferd. Cyperaceæ in Engler und Prantl's: Die natürlichen Pflanzenfamilien. Leipzig, 1887, p. 99.
10. Poiteau, M. Mémoire sur l'embryon des Graminées, des Cypéracées et du Nelumbo. Ann. du Muséum, vol. xiii, Paris, 1809.
11. Richard, L. C. Analyse botanique des embryons endorrhizes ou monocotylédonnées. Ann. du Muséum, vol. xvii, Paris, 1813, p. 455.
12. Rikli, Martin. Beiträge zur vergleichenden Anatomie der Cyperaceen mit besonderer Berücksichtigung der inneren Parenchymscheide. Inaug. diss. Berlin, 1895.
13. Rottböhl, Christen Friis. Descriptiones plantarum rariorum iconibus illustrandas. Hafniæ, 1772, p. 27, No. 78.
14. Seignette, A. Recherches anatomiques et physiologiques sur les tubercules. Thesis. Paris, 1889, p. 26.
15. Tieghem, Ph. Van. Observations anatomiques sur le cotylédon des Graminées. Ann. d. sc. nat. Bot. Ser. 5, vol. xv, Paris, 1872.
16. Turpin, P. I. F. Mémoire sur l'inflorescence des Graminées et des Cypérées. Mém. du Muséum, vol. v, Paris, 1819, plate 30, fig. 1.
17. Volkens, Georg. Die Flora der ägyptisch-arabischen Wüste. Berlin, 1887, p. 73.
18. Warming, Eug. Forgreningen og Bladstillingen hos Slægten Nelumbo. Vidensk. Medd. naturhist. For. Kjöbenhavn, 1879–80, p. 446.

EXPLANATION OF FIGURES.

PAGE 25.

- FIGURE 1 and 1b.—Seedlings of *Fuirena squarrosa*. 9 × natural size.
(For explanation of the letters see the text.)
- FIGURE 2.—Rhizome of *F. squarrosa*; natural size.
- FIGURE 3.—Part of figure 2, enlarged.
- FIGURE 4.—Branch of a similar rhizome; natural size.
- FIGURE 5.—Same, enlarged.
- FIGURE 6.—Clado-prophyllon from the lateral spike-bearing peduncle of *F. squarrosa*; $1\frac{1}{2}$ × natural size.
- FIGURE 7.—Rhizome of *F. scirpoidea*; natural size.
- FIGURE 8.—Same, enlarged.
- FIGURE 9.—Part of a similar rhizome; natural size.

PAGE 26.

- FIGURE 10.—Prophyllon from the base of a lateral spike of *F. squarrosa*; much enlarged.
- FIGURE 11.—Bract from a spike of *F. squarrosa*; 6 × natural size.
- FIGURE 12.—Prophyllon of *F. scirpoidea*; much enlarged.
- FIGURE 13.—Bract of same; 6 × natural size.

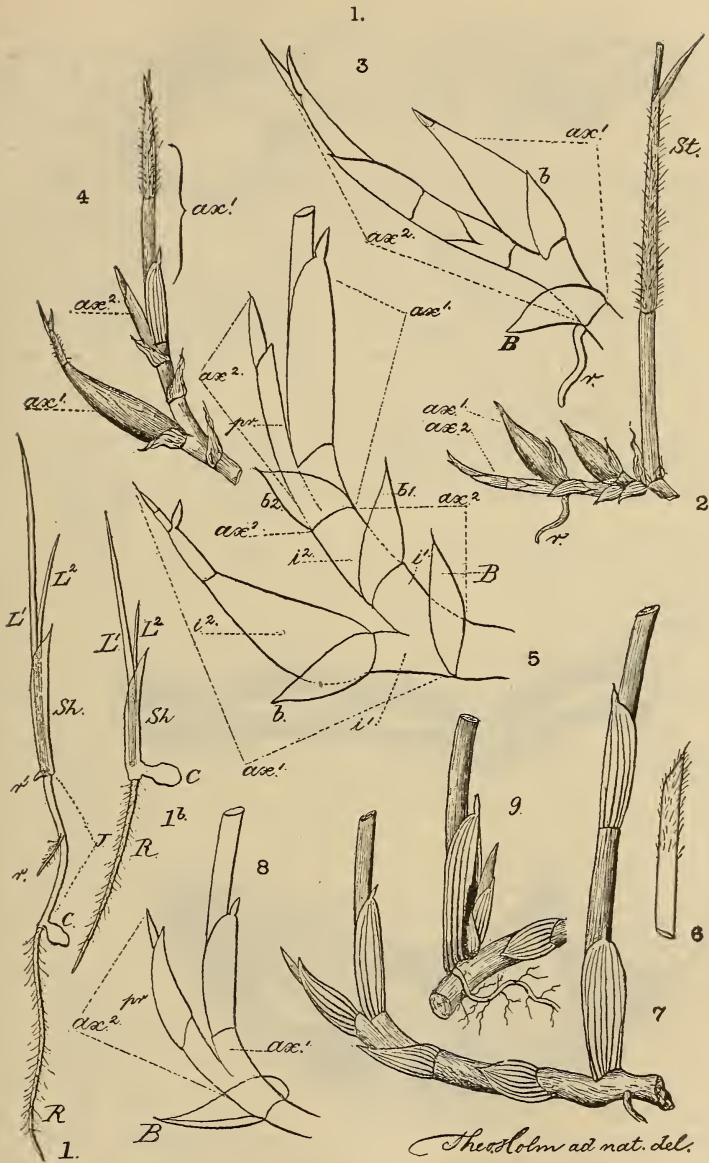

FIGURE 14.—Transverse section of stem-leaf of *F. squarrosa*. Ep. sup. and Ep. inf. = epidermis of the superior and the inferior face; 75 × natural size.

FIGURE 15.—Stoma from the same leaf, transverse section; 320 × natural size.

FIGURE 16.—Transverse section of the root of *F. squarrosa*; *B* = the bark; *End* = the endodermis; *Pr* = the pericambium; *PH* = the protohadrome; 320 × natural size.

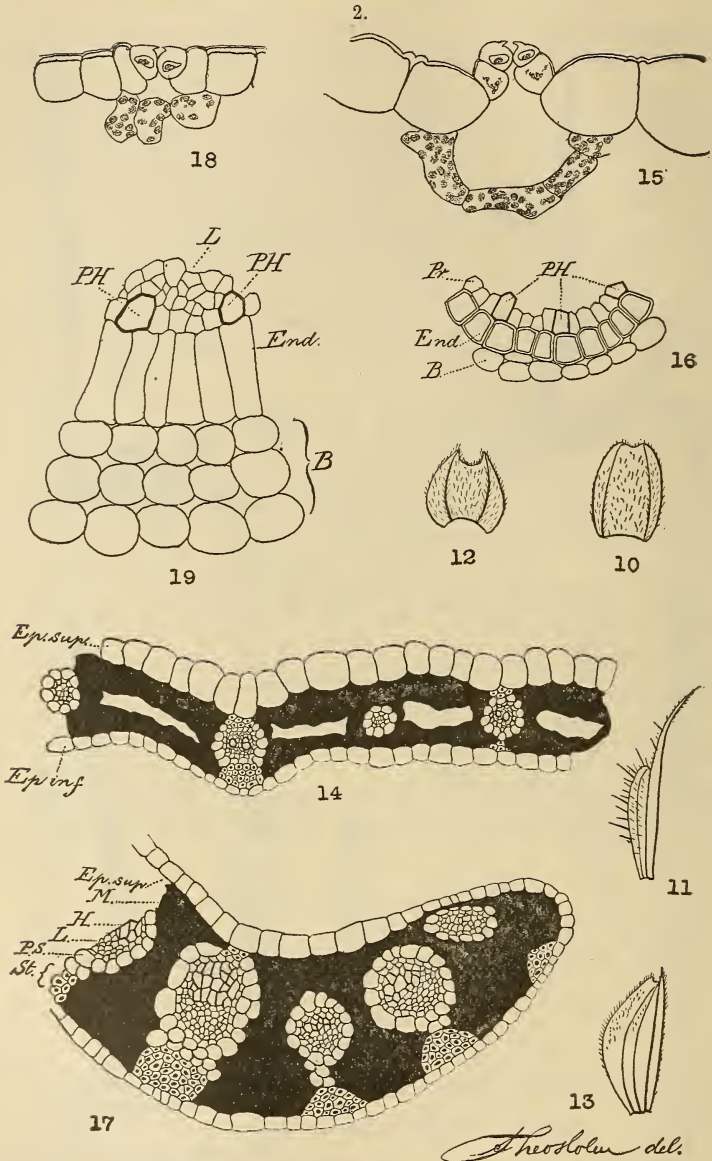

FIGURE 17.—Transverse section of the leaf-blade of *F. scirpoidea*; *Ep. sup.* = epidermis of the superior face; *M* = the mesophyll; *H* = the hadrome; *L* = the leptome; *PS* = the parenchyma-sheath; *St* = the stereome; 75 × natural size.

FIGURE 18.—Stoma from the same leaf; 320 × natural size.

FIGURE 19.—Transverse section of the root of *F. scirpoidea*; letters as in figure 16; 320 × natural size.

(The black in figures 14 and 17 indicates the chlorophyll-bearing tissue, the mesophyll.)

ART. IV.—*On the Identity of Chalcostibite (Wolfsbergite) and Guejarite, and on Chalcostibite from Huanchaca, Bolivia*; by S. L. PENFIELD and A. FRENZEL.

Introduction.—In December, 1894, Mr. Thomas Hohmann, mining engineer at Valparaiso, Chili, sent to one of us (Frenzel), for examination, some specimens, from the Pulacayo mine, Huanchaca, Bolivia. Upon one of these were some prismatic crystals of a mineral with metallic luster, which, we were informed by Mr. Hohmann, was found very sparingly, was unknown to him, and might possibly be new or worthy of investigation. As the material was limited, it was decided to identify the mineral, if possible, by its crystalline form, and, upon examination, it was found that the cleavage and some of the prominent crystal forms corresponded to the rare mineral guejarite, described by Cumenge* as having the composition $\text{Cu}_2\text{S} \cdot 2\text{Sb}_2\text{S}_3$.

About the same time that this material was sent to us, a second specimen from Huanchaca was received at the *Mineralien Niederlage* at Freiberg, Saxony, and Herr Zinkeisen, director of that institution, on learning that the mineral had been identified as guejarite, sent the specimen to Mr. L. Fletcher of London, and it was purchased for the mineral collection of the British Museum. In order to identify this mineral with certainty, Mr. Fletcher requested Mr. L. J. Spencer, of the Mineral Department of the British Museum, to examine the crystals, when it was found that the forms agreed not only with guejarite, but equally well with chalcostibite (wolfsbergite). An article was accordingly prepared by Mr. Spencer "On Wolfsbergite from Bolivia; and the probable identity of Wolfsbergite and Guejarite,"† but on learning that we were engaged in an investigation of the same mineral, Mr. Fletcher called our attention to the fact that guejarite could not be distinguished crystallographically from chalcostibite. He also requested Mr. Spencer to send the results of his investigation to us, in order that his results might be incorporated with ours, and in subsequent pages it will be shown that guejarite, which has been considered as having the composition $\text{Cu}_2\text{S} \cdot 2\text{Sb}_2\text{S}_3$, is really identical with chalcostibite (wolfsbergite), $\text{Cu}_2\text{S} \cdot \text{Sb}_2\text{S}_3$.

Chalcostibite from Wolfsberg in the Harz.—Upon material from this locality, the species was first founded in 1835, by Zinken,‡ the mineral being called by him *Kupferantimonglanz*.

* Bull. Soc. Min. de France, ii, p. 201, 1879.

† Read before the Mineralogical Society of London, April 14, 1896.

‡ Pogg. Ann., xxxv, p. 357, 1835.

The composition $\text{Cu}_2\text{S} \cdot \text{Sb}_2\text{S}_3$ was established by an analysis by H. Rose,* and the crystals were measured and determined to be orthorhombic by G. Rose,† who identified two prisms and a pinacoid in one zone, but as no terminal faces were observed, the axial ratio could not be fully determined. The name *rosite* was assigned to the species in 1841, by Huot,‡ but on account of its similarity to *roselite*, it has not been generally accepted. In 1847 the mineral was called *chalcostibite* by Glocker,§ and in 1849 *wolfsbergite*, by Nicol.|| Glocker's name thus antedates Nicol's, and there seems to be no reason for not accepting it, although wolfsbergite is in common use.

Terminated crystals of chalcostibite from Wolfsberg are very rare, and we are indebted to Laspeyres¶ for the only description of them, and for the determination of the axial ratio. In order to show a crystallographic relation between chalcostibite and the similarly constituted minerals zinkenite, $\text{PbS} \cdot \text{Sb}_2\text{S}_3$; sartorite, $\text{PbS} \cdot \text{As}_2\text{S}_3$ and emplectite, $\text{Cu}_2\text{S} \cdot \text{Bi}_2\text{S}_3$, the crystals were orientated so as to make the perfect cleavage basal, and the prominent prismatic development parallel to the crystallographic axis *b*.

The forms that were identified by Laspeyres are as follows:

| | | | |
|----------------|----------------|----------------|----------------------|
| <i>c</i> , 001 | <i>d</i> , 101 | <i>f</i> , 011 | <i>p</i> , 7·14·8** |
| <i>e</i> , 307 | <i>g</i> , 201 | <i>q</i> , 863 | <i>r</i> , 7·21·27** |

The axial ratio was derived from measurements of the pyramid *p*, and was found by Laspeyres to be $a:b:c = 0.5283:1:0.6234$, but by giving to *p* the indices 6·12·7 instead of 7·14·8, the axial ratio becomes $0.5283:1:0.6364$. Some of the important measurements made by Laspeyres will be found in column I, in the tables on page 34, et seq.

Chalcostibite (guejarite) from Guejar in Spain.—The identity of guejarite as a distinct mineral species had been based upon the following analysis by Cumenge: ††

| | Found. | Theory for $\text{Cu}_2\text{S} \cdot 2\text{Sb}_2\text{S}_3$. |
|----------|---|---|
| S | 25·0 | 27·0 |
| Sb | 58·5 | 57·8 |
| Cu | 15·5 | 15·2 |
| Fe | 0·5 | --- |
| Pb | tr. | --- |
| | <hr style="width: 50%; margin: 0 auto;"/> | <hr style="width: 50%; margin: 0 auto;"/> |
| | 99·5 | 100·0 |

* *Ibid*, p. 361.

† *Mineralogy*, i, p. 197.

‡ *Mineralogy*, p. 484.

† *Ibid*, p. 360.

§ *Syn.*, p. 32.

¶ *Zeitschr. Kryst.*, xix, p. 428, 1891.

** As will be shown later, 7·14·8 and 7·21·27 should be 6·12·7 and 134, respectively.

†† *Loc. cit.*

Although the results agree fairly well with the theoretical composition, an analysis in which the determinations are carried out only to half per cents cannot be considered wholly satisfactory for the establishment of a mineral species, and, as neither the method of analysis is given nor any statement concerning the amount of material taken, the results cannot be fairly criticised. As crystals of chalcostibite resemble those of stibnite in color, luster, habit, and cleavage, and, further, as stibnite would probably occur at a locality where chalcostibite is found, as is the case at Wolfsberg in the Harz, it is possible that the material analyzed by Cumenge contained some stibnite, which would account for his failure to obtain the correct formula. It may be noted here that Rammelsberg, in the second supplement of his *Handbuch der Mineralchemie*, p. 54, 1895, places an interrogation after the formula of guejarite.

The crystallization of the mineral was determined as orthorhombic by C. Friedel.* The habit is prismatic, with the faces in the prominent zone striated and grading into one another, owing to oscillatory combinations of a series of prisms. Crystals showing terminations are rare. In the position adopted by Friedel, the nearly perfect cleavage in the prismatic zone was taken as b , 010, and the following forms were identified :

| | | | |
|-----------|------------|------------|-----------|
| b , 010 | h , 210 | m , 110 | d , 013 |
| c , 001 | k , 320† | l , 230† | e , 011 |

In addition to the foregoing, the doubtful forms 410, 310, and 032 are mentioned and likewise two pyramids, x ($b \wedge x = 56^\circ 24'$), and z ($b \wedge z = 39^\circ 58'$), but the symbols of these latter forms cannot be determined, as only a single measurement is given for each. The axial ratio obtained by Friedel is $a : b : c = 0.8221 : 1 : 0.7841$.

In order to bring the crystals into the position adopted by Laspeyres for chalcostibite, it is necessary to change the orientation so that the nearly perfect cleavage is basal, c , 001, and the prominent prismatic zone parallel to the crystallographic axis b . Twice the length of Friedel's vertical axis is taken as the unit length of b , and the axial ratio thus becomes $a : b : c = 0.5242 : 1 : 0.6377$, while that derived from Laspeyres' measurements is $a : b : c = 0.5283 : 1 : 0.6364$.

In the following table, the forms observed by Friedel are given, together with the indices when transposed to the position adopted by Laspeyres :

* Bull. Soc. Min. de France, ii, p. 203, 1879.

† The forms 320 and 230 are given by Friedel as 730 and 370, respectively.

| Guejarite. Position. | | Chalcostibite. Position. | Guejarite. Position. | | Chalcostibite. Position. |
|-------------------------|---|-----------------------------|-------------------------|---|-----------------------------|
| <i>b</i> , 010 | = | <i>c</i> , 001 | <i>m</i> , 110 | = | <i>d</i> , 101 |
| <i>c</i> , 001 | = | <i>b</i> , 010 | <i>l</i> , 230 | = | <i>h</i> , 203 |
| <i>h</i> , 210 | = | <i>g</i> , 201 | <i>d</i> , 013 | = | <i>u</i> , 061 |
| <i>k</i> , 320 | = | <i>i</i> , 302 | <i>e</i> , 011 | = | <i>t</i> , 021 |

At the conclusion of his article, Friedel calls attention to the close similarity in the angle of his prism, $m \wedge m = 101^\circ 9'$, with that of the chalcostibite prism $101^\circ 0'$ measured by Rose.

In the Brush collection at New Haven, there is a specimen of chalcostibite from Guejar, which was presented by Professor Groth of Munich. It is a fragment of a crystal, without terminal planes, and in appearance it agrees exactly with the description of guejarite given by Friedel. However, in order to make sure of its identity with the material described by him, it was carefully measured, with the results which will be found in column IV in the table on page 34. The specimen weighed a little over one gram, and the specific gravity was found to be 4.959. Cumenge gives 5.03.

Professor Groth very kindly responded to a request to supply us with some of this rare material for a chemical analysis, and he also furnished measurements of a crystal with terminal planes, belonging to the Munich collection. These measurements were made by Mr. Schott, and are given in column V on page 34. The habit of this crystal is shown in fig. 1.



Requests for material were also sent to Professor Friedel and Mr. Cumenge, and they were able to supply us with some of the original mineral from Guejar investigated by them. That received from Professor Friedel was a small fragment of a crystal, weighing 0.108 gram, which corresponded in every particular with that given to us by Professor Groth. Before using it for analysis, however, it was carefully measured, with the results which are given in column III on page 34. The material supplied by Mr. Cumenge consisted of small, finely striated crystal fragments which were not adapted for measurement. They weighed 0.428 gram, and, before subjecting them to analysis, each crystal was tested for copper so as to make sure that there were no stibnite crystals amongst them.

The results of the analyses (by Frenzel) of the specimens received from Professors Groth and Friedel, and Mr. Cumenge, are given below in the columns I, II and III respectively.

| Specific gravity 4.96. | | Ratio. | | II. | III. | Theory for Cu ₂ S. Sb ₂ S ₃ . | |
|------------------------|-----------------|--------|--------------|-----|--------|---|------|
| I. | | | | | | | |
| S. | 26.28 ÷ 32 = | .821 | 4.00 | S | 26.12 | 25.87 | |
| Sb | 48.86 ÷ 120 = | .407 | 1.995 | Sb | 48.50 | 48.50 | |
| Cu | 24.44 ÷ 126.8 = | .193 | } .202 0.995 | Cu | 25.92 | 25.63 | |
| Pb | .58 ÷ 207 = | .002 | | Pb | ---- | .32 | ---- |
| Fe | .42 ÷ 56 = | .007 | | Fe | ---- | .49 | ---- |
| | | | | Zn | ---- | .18 | ---- |
| <hr/> | | | | | <hr/> | <hr/> | |
| 100.58 | | | | | 100.78 | 100.00 | |

In the first analysis the ratio of S:Sb:(Cu₂+Pb+Fe) is almost exactly 4:2:1, which is that demanded by the chalcostibite formula Cu₂S.Sb₂S₃. The results of the second and third analyses are almost identical with those of the first, so we are thus enabled to establish beyond all doubt the identity in chemical composition of guejarite with chalcostibite.

Chalcostibite from Huanchaca, Bolivia.—On the specimen sent to us by Mr. Hohmann, the chalcostibite occurred as prismatic crystals averaging about 1^{mm} in diameter and 2^{mm} in length, which were attached to a gangue of quartz and pyrite vein material. Some massive tetrahedrite was also present, but the chalcostibite crystals were not found directly upon it. Although the crystals were isolated and quite numerous, only a few were implanted so that they could be removed and used for measurement. Doubly terminated ones were not observed. The crystals are quite highly modified, and the forms that have been identified are given in the following table, where those which are new are indicated by an asterisk:

| | | | |
|------------------------------|-----------------|-------------------|--------------------|
| <i>c</i> , 001 | <i>h</i> , 203* | <i>t</i> , 021 | <i>ν</i> , 133* |
| <i>l</i> , 130* | <i>d</i> , 101 | <i>u</i> , 061 | <i>π</i> , 265* |
| <i>Δ</i> , 209* | <i>i</i> , 302* | <i>q</i> , 863 | <i>ρ</i> , 263* |
| <i>Δ</i> ₁ , 207* | <i>g</i> , 201 | <i>p</i> , 6.12.7 | <i>σ</i> , 4.12.5* |
| <i>Δ</i> ₂ , 205* | <i>s</i> , 065* | <i>μ</i> , 136* | <i>τ</i> , 261* |

The large development of the pyramids *p* and *q*, whose indices are complicated, corresponds almost exactly with the description given by Laspeyres of the occurrence of the same found on the crystals from Wolfsberg. These pyramids were free from striations and vicinal developments, and gave excellent reflections. A few crystals were observed which have the habit represented in fig. 3, by a projection upon the pinacoid 010. All the pyramidal forms given in the foregoing table were observed upon a single crystal of this habit, but, of the faces in the zone between *c* and *l*, all of which were quite small, *μ*, *ν* and *σ* are not represented in the figure.

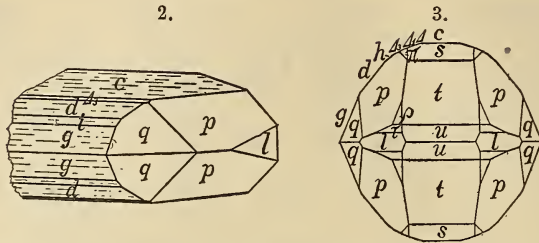

The axial ratio given below was derived from exceptionally good measurements of the pyramid *q*, 863.

$$863 \wedge \bar{8}63 = 126^\circ 21'$$

$$863 \wedge \bar{8}6\bar{3} = 138^\circ 21'$$

$$a : b : c = 0.5312 : 1 : 0.63955$$

Laspeyres' measurements yield 0.5283 : 1 : 0.6364

Friedel's measurements yield 0.5242 : 1 : 0.6377

A list of the measured angles will be found in column VI in the tables on page 34, et seq.

Although the amount of material was limited, by careful selection a sufficient quantity of the pure, crystallized mineral was obtained for a chemical analysis, which was made by Frenzel, and gave the following results, corresponding with the theory demanded by the chalcostibite formula :

| | Found. | Theory for $\text{Cu}_2\text{S} \cdot \text{Sb}_2\text{S}_3$. |
|----------|--------|--|
| S | 26.20 | 25.87 |
| Sb | 48.45 | 48.50 |
| Cu | 24.72 | 25.63 |
| | 99.37 | 100.00 |

Mr. L. J. Spencer gives the following description of the chalcostibite specimen from Huanchaca, belonging to the British Museum. The small, bright, blade-shaped crystals of chalcostibite occur upon a specimen consisting mostly of massive and crystallized quartz, pyrite and tetrahedrite. The chalcostibite crystals are flattened parallel to the pinacoid *c*, 001, and are elongated and striated parallel to the crystallographic axis *b*. They are sometimes terminated at the ends by unsymmetrically developed, narrow, pyramidal planes, but more often by dull rounding surfaces approximating in position to the pinacoid 010. The forms that were observed are given in the table below, those which are new being indicated by an asterisk :

| | | |
|--------------|-----------------|-------------------|
| η , 205 | g , 201 | γ , 474* |
| i , 302 | α , 233* | δ , 475* |
| d , 101 | β , 354* | ϵ , 476* |

The measurements obtained by him will be found in column VII in the tables on page 35.

Summary of the crystallographic investigations.—The following table includes all the forms which have been identified

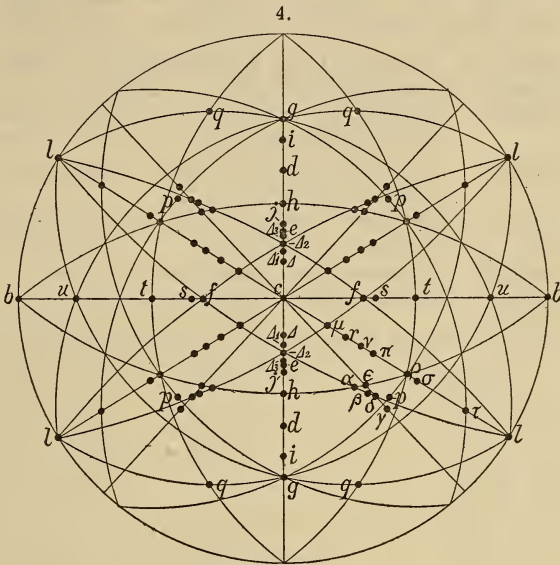

on chalcostibite, and their distribution is shown by the spherical projection, fig. 4 :

| | | | | |
|------------------|------------------|--------------|-------------------|------------------|
| b , 010 | Δ_3 , 205 | f , 011 | μ , 136 | τ , 261 |
| c , 001 | e , 307 | s , 065 | r , 134 | α , 233 |
| l , 130 | j , 102 | t , 021 | ν , 133 | β , 354 |
| Δ , 209 | h , 203 | u , 061 | π , 265 | γ , 474 |
| Δ_1 , 207 | d , 101 | q , 863 | ρ , 263 | δ , 475 |
| Δ_2 , 103 | i , 302 | p , 6.12.7 | σ , 4.12.5 | ϵ , 476 |
| | g , 201 | | | |

All investigators call attention to the striated character of the crystals in the direction of the crystallographic axis b , and, owing to the difficulty of always obtaining reliable measurements, there may be uncertainty in the identification of some of the forms in the zone 100:001. The only forms which have been identified as prominent ones in this zone are h , d , and g . The prominent development of the pyramids p and q with such complicated indices as 6.12.7 and 863, respectively, on crystals from both Wolfsberg and Huanchaca, is certainly very unusual, and there seems to be nothing gained by giving to one of these forms simpler indices, since that would add very much to the complexity of the remaining forms.

In addition to the perfect basal cleavage, traces of cleavages parallel to the pinacoids 100 and 010 were observed.

In the succeeding tables, the calculated values are derived from the axial ratio $a:b:c = 0.5312:1:0.63955$, and the measurements made by various investigators are indicated by Roman numerals placed above the columns, as follows:

- I. Laspeyres. Crystals from Wolfsberg in the Harz.
- II. Friedel. Crystals from Guejar in Andalusia.
- III. Penfield. Fragment of crystal from Guejar, received from Prof. Friedel.
- IV. Penfield. Fragment of crystal from Guejar, received from Prof. Groth.
- V. Schott. Terminated crystal from Guejar, belonging to the Munich collection.
- VI. Penfield. Crystals from Huanchaca, Bolivia.
- VII. Spencer. Crystals from Huanchaca, Bolivia.

Measurements from the base c, 001 on to faces in the zone 001:100.

| | Calculated. | I. | II. | III. | IV. | V. | VI. |
|---------------------------|-------------|---------|---------|---------|---------|---------|---------|
| $c \wedge \Delta$, 209 | 14° 59' | | | | | | 14° 10' |
| $c \wedge \Delta_1$, 207 | 18 59 | | | | | | 17 40 |
| $c \wedge \Delta_2$, 103 | 21 52 | | | 21° 55' | 22° 21' | | |
| $c \wedge \Delta_3$, 205 | 25 43 | | | | | | 25 55 |
| $c \wedge e$, 307 | 27 17½ | 27° 12' | | | 27 11 | | |
| $c \wedge j$, 102 | 31 3 | | | 31 3 | | | |
| $c \wedge h$, 203 | 38 45 | | 39° 58' | 38 45 | 38 46 | 38° 51' | 37 |
| $c \wedge d$, 101 | 50 17 | 51 22 | 50 34½ | 50 32 | 50 25 | 50 18 | 50 42 |
| $c \wedge i$, 302 | 61 1½ | | 62 50 | | | | 61 45 |
| $c \wedge g$, 201 | 67 27 | 66 28 | 67 39 | 67 8 | 67 22 | 67 24 | 67 24 |

To the foregoing may be added the measurements of Rose $c \wedge d = 50^\circ 30'$ and $c \wedge g = 67^\circ 36'$, and the following by Spencer: $c \wedge \Delta_3 = 25^\circ 49'$ (mean of $25^\circ 51'$, $25^\circ 55'$, $25^\circ 51'$ and $25^\circ 35'$) and $c \wedge i = 63^\circ$, 63° and $63^\circ 13'$. These last measurements by Spencer and one given by Friedel, $c \wedge i = 62^\circ 50'$, may indicate the existence of a form 805 ($001 \wedge 805 = 62^\circ 34'$) instead of the more probable one i , 302.

Measurements obtained from faces in the zones 100:010 and 010:001.

| | Calculated. | I. | II. | V. | VI. |
|----------------------------------|-------------|--------|---------|---------|---------|
| $l \wedge l$, 130 \wedge 130 | 64° 13' | | | | 64° 22' |
| $c \wedge f$, 001 \wedge 011 | 32 36 | | 32° 21' | | |
| $f \wedge f$, 011 \wedge 011̄ | 114 48 | 116 31 | | | |
| $s \wedge s$, 065 \wedge 065̄ | 104 59½ | | | | 105 24 |
| $c \wedge t$, 001 \wedge 021 | 51 59 | | | 51° 54' | |
| $t \wedge t$, 021 \wedge 021̄ | 76 2 | | | | 76 21 |
| $c \wedge u$, 001 \wedge 061̄ | 75 23½ | | 75 23 | 75° 24' | |
| $u \wedge u$, 061 \wedge 061̄ | 29 13 | | | | 29 32 |

Measurements obtained from pyramidal faces.

| | Calculated. | I. | VI. | VII. |
|---|---------------------|---------------------|---------------------|-----------|
| $q \wedge q$, 863 \wedge $\bar{8}63$ | 126° 21' | 126° 31' | 126° 21'* | |
| $q \wedge q$, 863 \wedge $\bar{8}6\bar{3}$ | 138 21 | | 138 21* | |
| $q \wedge g$, 863 : 86 $\bar{3}$ | 32 16 $\frac{1}{2}$ | 32 18 | 32 16 | |
| $p \wedge p$, 6·12·7 \wedge $\bar{6}$ ·12·7 | 69 38 | 69 49 | 69 34 | |
| $p \wedge p$, 6·12·7 \wedge $\bar{6}$ ·12· $\bar{7}$ | 105 19 | | 105 16 | |
| $p \wedge p$, 6·12·7 \wedge 6·12· $\bar{7}$ | 67 11 | 67 18 $\frac{1}{2}$ | 67 11 $\frac{1}{2}$ | |
| $c \wedge v$, 001 \wedge 136 | 20 41 | | 20 18 | |
| $c \wedge r$, 001 \wedge 134 | 29 31 $\frac{1}{2}$ | 30 2 $\frac{1}{2}$ | | |
| $f \wedge r$, 011 \wedge 134 | 16 40 $\frac{1}{2}$ | 16 22 | | |
| $d \wedge r$, 101 \wedge 134 | 40 45 $\frac{1}{2}$ | 40 32 $\frac{1}{2}$ | | |
| $c \wedge v$, 001 \wedge 133 | 37 3 | | 36 45 | |
| $c \wedge \pi$, 001 \wedge 265 | 42 11 | | 41 46 | |
| $c \wedge \rho$, 001 \wedge 263 | 56 29 | | 56 12 | |
| $c \wedge \sigma$, 001 \wedge 4·12·5 | 61 6 $\frac{1}{2}$ | | 61 8 | |
| $c \wedge \tau$, 001 \wedge 261 | 77 33 | | 77 32 | |
| $c \wedge a$, 001 \wedge 233 | 45 44 $\frac{1}{2}$ | ----- | ----- | 46° |
| $\Delta_3 \wedge a$, 205 \wedge 233 | 29 19 $\frac{1}{2}$ | | | 30 |
| $c \wedge \beta$, 001 \wedge 354 | 50 20 | | | 50 28' |
| $\Delta_3 \wedge \beta$, $\bar{2}05 \wedge 354$ | 71 2 | | | 71 9 |
| $d \wedge \beta$, 101 \wedge 354 | 92 2 | | | 92 1 |
| $c^\circ \wedge \gamma$, 001 \wedge 474 | 58 41 | | | 58 43 |
| $\Delta_3 \wedge \gamma$, 205 \wedge 474 | 42 18 $\frac{1}{2}$ | | | 42 3 |
| $d \wedge \gamma$, 101 \wedge 474 | 35 34 | | | 34 53 |
| $c \wedge \delta$, 001 \wedge 475 | 52 45 | | | 52 25 |
| $c \wedge \epsilon$, 001 \wedge 476 | 47 37 | | | 45 to 47° |

In the preceding tables, many of the measurements show considerable variation from the calculated values, which might be expected, owing to the striated character of some of the faces and the small size of others. On the other hand, the measurements from the best and most prominently developed forms, h , d , g , v , q , and p , show a very close agreement with the calculated values, and it is believed that the axial ratio which we have established is more accurate than those given by other investigators.

It is probable that the pyramid x mentioned by Friedel ($c \wedge x = 56^\circ 24'$) is p , 6·12·7 ($c \wedge p$ calculated = $56^\circ 24\frac{1}{2}'$), which is prominently developed on the crystals from Wolfsberg and Huanchaca.

In conclusion, we take great pleasure in expressing our thanks to Professors Friedel and Groth, and Messrs. Cumenge, Hohmann, Spencer, Schott and Fletcher, who have rendered valuable assistance by supplying us with material for this investigation and information concerning the mineral.

ART. V.—*An Interesting Case of Contact Metamorphism;*
by H. W. FAIRBANKS.

BLACK Mountain is the highest peak of the El Paso range, a spur of the Sierra Nevada mountains extending easterly into the Mojave desert. The mountain owes its name to the mantle of dark lavas which covers it. The underlying rocks constitute a part of an extensive series of sedimentary beds exposed for many miles along the northern slope of the El Paso range. They consist of sandstones, clays and conglomerates and contain in places much fragmental volcanic material as well as occasionally interstratified flows. Last Chance gulch and its tributaries drain the western slope of Black Mountain and in the cañons the character of the sedimentary beds, as well as their relation to the volcanic flows, is often finely shown. The sedimentary beds here have a light yellowish or pinkish color and exhibit in places a finely banded appearance. In the field they were thought to be wholly of volcanic origin, but a microscopic examination revealed the fact that the light-colored paste in which the more distinct fragments were embedded consists of an amorphous kaolin-like substance. The small partly-rounded pebbles and grains appear to be of many kinds, but those of a volcanic nature predominate.

The strata have been considerably disturbed and faulted, and in one of the cañons have been intruded by two dikes. One of these has a diameter of less than one foot while the other is 14 feet across. The larger one cuts vertically through the sedimentary rocks which dip at an angle of about 25 degrees. This dike appears very fine-grained, but a microscopic examination shows that it is holocrystalline. The feldspar is probably labradorite and occurs in long laths. The augite has a pale brown color and gives an ophitic structure to the rock. Abundant grains of a reddish color and presenting the appearance of having resulted from the alteration of olivine are scattered through the rock. Owing to the absence of a glassy base the rock is then an olivine diabase. The surface of the outcrop is quite decomposed and weathers away as rapidly as the soft and slightly tufaceous beds.

The remarkable feature connected with the intrusion is the striking manner in which the adjoining rock has been metamorphosed. The thickness of the band of altered tufa is about two feet where it is best exposed. The light colored-soft rock has been baked to a dark hard and very firm one, the slabs of which give forth a ringing sound when struck. A microscopic examination does not reveal any new minerals, but only the fact that the alteration has brought out more clearly the vol-

canic nature of the most of the fragments. The metamorphosed layer weathers out more strongly, as the photograph shows, than either the dike or the unaltered tufa, forming a prominent and sharply defined band extending up the side of the cañon.



Contact metamorphism in the El Paso range, California. The soft tufa lies on the right of the picture, the slaty contact zone in the middle, the diabase dike on the left.

In addition to the pronounced manner in which the rock has been baked there is another striking feature. The hardened layer is not massive, but on the contrary, breaks up into thin and regular slate-like slabs parallel to the wall of the dike. The photograph shows the main lines of fissility and the slabs broken off and strewn over the side of the cañon. An examination of any one of these slabs shows that it also is thickly penetrated by fine parallel seams which are slightly irregular and discontinuous, but which under the action of the weather

would develop into further parting planes. Where these cracks pass through the larger pebbles the latter do not appear to be faulted in the least, so that we cannot attribute their origin to the action of a shearing stress. The most probable explanation which has occurred to the writer is that the partings are due to contraction on cooling. This theory would explain the local irregularities as well as the general parallelism with the dike.

Berkeley, California.

ART. VI.—*The Tin Deposits at Temescal, Southern California*; by HAROLD W. FAIRBANKS.

Introduction.—Several years ago, shortly prior to the final suspension of work upon the Temescal tin deposits, the writer was given exceptional facilities for a careful examination of the mine and the country immediately surrounding it. Subsequently a brief description was published,* but owing to the political importance of the question at the time no thorough report was attempted. Descriptions of the tin veins occurring here have been given by Blake† and Hanks,‡ although little has been published concerning the conditions under which the veins occur and the nature of the ore bodies. In the present paper the writer will add to what is already known, a more detailed description of the veins and the country in which they are found. The report of Hanks referred to above contains an outline of the history of the discovery and the excitement following it, the purchase of the old Mexican grant and the final development by the English company, so that this part of the subject will not be touched upon.

General Geology of the District.—The Temescal tin mine is located in the northwestern portion of the San Jacinto grant about five miles southeast of South Riverside. This portion of the grant consists of rolling hills having an elevation of nearly 1,000 feet, and formed of a great variety of rocks. To the west, separated by the Temescal valley filled with late Miocene sediments, is the Santa Ana range, the most striking topographic feature of the region. It is high and steep, contrasting strongly with the rolling though sometimes quite mountainous country to the northeast. Its elevation is doubtless due to a great fault line, the northern portion of which passes through the Temescal valley. Immediately adjoining the valley on the east is a more or less connected strip of highly metamorphosed rocks associated with porphyries, but the most of the country in that direction is granite.

The tin deposits lie nearly in the center of a rudely semi-circular area of granite about two miles in diameter and connected on the east with the great body of similar rock extending indefinitely in that direction. The sedimentary rocks along the edge of the granite area consist of quartzite, mica schist and conglomerate of unknown age. A part at least of the slates and limestones of the Santa Ana range are

* XIth Report of the State Mining Bureau, p. III.

† Mineral Resources of the United States, 1883-84, p. 614.

‡ IVth Report of the State Mining Bureau, p. 120.

Carboniferous, but further than that we have no information. Extensive bodies of porphyry also border the granite. They vary much in appearance, in some places being of a grayish color and almost devoid of distinct crystals, but more generally the rock presents a groundmass almost black in color in which are sprinkled white feldspar crystals and more rarely those of quartz. It is difficult to say which is the older, the granite or the porphyry. In the neighborhood of the junction both rocks change their character somewhat, although each is distinct. With perhaps one exception, none of the fine-grained granitic dikes abundant in the coarse granite were noticed penetrating the porphyry, but there are bunches and dike-like protrusions of the latter in the granite near the contact.

The granite is distinctly intrusive in the metamorphic rocks, as bunches of it project up through them here and there. The granite varies considerably in texture although the main body has a uniform composition. Macroscopically it shows two kinds of feldspar, one a pale brownish color and the other white, abundant quartz and a small amount of the dark silicate. Under the microscope it is seen to consist of plagioclase, orthoclase, and quartz in nearly equal proportions, with a much less amount of biotite mica. Towards the outer edges of the granitic boss in which the mine is situated are numerous dikes of a very fine-grained granite consisting almost wholly of quartz and orthoclase in interlocking grains. The proportion of quartz seems to be greater in some of these dikes than in the coarse granite to which they are genetically related.

The Vein System and Tin Deposits.—The semicircular area of granite and portions of the adjoining porphyry have been fissured in a general northeast and southwest direction along almost innumerable lines and a black vein matter deposited. The veins are generally small, varying from one-fourth to a few inches in thickness, but in the case of the main tin-bearing vein an enormous size is reached at Cajalco hill. As the hill is approached the veins become larger, and finally culminate in this elevation, which is about 300 by 250 feet in diameter at the base. The veinstone of which it is mostly composed rises in prominent and bold croppings. With one or two unimportant exceptions the material of which this as well as the other veins is formed consists wholly of tourmaline and quartz, with which the tin ores are locally associated. The larger veins, and the Cajalco in particular, are very irregular in size, sometimes appearing to be mere bunches in the granite. A few hundred feet northeast of the hill the vein has narrowed to 6 or 8 feet, and it is here that the large body of tin was first discovered and the main shafts sunk.

A slide prepared from one of the smaller veins, which in the

hand specimen appeared to consist wholly of tourmaline, showed bunches of tourmaline crystals radially arranged and embedded in interlocking quartz grains. The crystals are recognized as tourmaline by the hexagonal cross section, parallel extinction, polarization and frequent presence of fibrous terminations, although the terminal crystal faces are sometimes present. In the most of the sections prepared the tourmaline appears to be exceptionally opaque, sometimes the border is opaque while the center is feebly translucent. With the blow-pipe the material fused easily with slight intumescence and became magnetic. The reaction for boron was pronounced.

The large Cajalco vein consists of tourmaline and quartz in almost equal proportions. This aggregate breaks up quite easily, as it is porous, the spaces being lined with drusy crystals of both components. The deposits have evidently been formed in fissures through a gradual replacement of the granite walls. Judging from an examination of the seam-like veins the silicates appear to have been attacked easier and removed first. In places the larger veins seem to blend into the granite and it was at first thought that some of the quartz might be a remnant of the granite, as it is rarely if ever segregated in bunches. A microscopic examination showed that this view was undoubtedly false, as the grains interlock in a different manner from those in the granite, and in addition contained fluid and liquid inclusions. The relative proportions of quartz and tourmaline in the Cajalco vein are so constant that it presents a uniform appearance. Although the mine reports speak of the occasional presence of arsenical pyrites and copper, nothing of the kind came under the observation of the writer. The bunches in these veins, and especially the enormous one forming Cajalco hill, could have been formed in no other way than by replacement, although it is difficult to conceive of its having taken place on such a large scale.

With the earlier reports upon this property nearly all the veins were considered tin-bearing, but at the time the writer made the examination shortly before the mine closed, after diligent prospecting the company had succeeded in finding traces of tin in only one or two veins besides the one worked. Tunnels had also been run into Cajalco hill, but in this great body of vein matter nothing was found. The narrower portion of the vein to the northeast furnished all that was ever milled. At the time of the examination the vein had been opened to a depth of 180 feet by two working shafts, exposing the vein horizontally for 300 feet. Here the vein has a width of 8 feet or less. The main ore body occurs in the center of the mine between the two shafts and extends down on the dip of the vein. The tin oxide is distributed either through the

vein matter or in stringers and bunches. In the latter case it is sometimes found in nearly pure condition. The average of the ore milled was however only about 5 per cent of the oxide. Seams of clay are generally found on or near the sides of the vein, showing some movement since the deposition took place. The walls are quite irregular and sometimes bunches of granite are found wholly inclosed in the vein. The analysis of the ore made by Genth, and quoted by both Blake and Hanks, shows silicic acid 9·82 per cent, tungstic acid ·22, oxide of tin 76·15, oxide of copper ·27, oxides of iron and manganese, lime and alumina 13·54. This must have been an exceptionally pure specimen and wholly free from tourmaline.

The tin ore occurs in two forms; the more important and common variety is either massive and of a brownish color, or in clear reddish brown crystals lining cavities; the less common variety is that of "wood tin," which appears uncrystallized and in the form of thin layers.

It is not known to the writer whether the ore body which was being followed down finally ran out or not, but at any rate it appears that it was unprofitable to work. The great richness of the ore in places is one of the remarkable features of this deposit when compared with most of the other known occurrences of tin. Another remarkable fact is the great size of the main vein as shown in Cajalco hill and its uniformity and simplicity of composition. It appears that the contents of the veins represent the entire replacement of the granite bordering what were originally narrow fissures. The agent which accomplished this was probably heated water carrying various minerals in solution, the economically valuable one, tin, being deposited only in places under exceptional conditions.

ART. VII.—*Additional Notes on the Outlying Areas of the Comanche Series in Oklahoma and Kansas*; by T. WAYLAND VAUGHAN.

[Published by permission of the director of the U. S. Geological Survey.]

I WAS enabled during the past summer, while working under the direction of Mr. R. T. Hill, to study some areas of the Comanche formations in Kansas and Oklahoma, that have not been described in the literature pertaining to the region. I was also able to visit a locality reported by Cope from near old Camp Supply, and what is probably the original locality from which Marcou obtained the types of his *G. pitcheri* (= *G. navia* Hall, *G. rœmeri* Marcou, *G. forniculata* White). Marcou's were the first observations made in the region;* Cragin† has published numerous papers, and St. John‡ and Hay§ have made lesser contributions. Professor E. D. Cope|| has published some notes on beds near old Camp Supply. Mr. R. T. Hill¶ has given an extended review of the work that has been done in the whole region, and has published the results of a very careful study of the vicinity of Belvidere. The most recent contribution is that of Professor C. S. Prosser.**

The areas of the beds belonging to the Comanche Series, in Kansas, Oklahoma, Trans-Pecos, Texas, and New Mexico, have been denominated "Outlying Areas" by Mr. Hill because the connection between them and the main area of the Lower Cretaceous in Texas has been destroyed by erosion, or the beds in the intervening areas buried beneath the Plains Formation. There are great lithologic differences between the beds of the "Outlying Areas" and those of the main area: the most conspicuous is the entire absence of chalky formations in the former.

For the portion of the Comanche Series, exposed near Belvidere, the names Belvidere beds†† may be used. There are

* Geology of North America, pp. 22, 26, 27, 38, 39, 1858.

† Bulletin of the Washburn College Laboratory, vol. i, No. 3, pp. 85-91, 1885; vol. ii, No. 9, pp. 33-37, February, 1889; vol. ii, No. 10, pp. 65-68, December, 1889; vol. ii, No. 11, pp. 69-80, March, 1890; American Geologist, vol. vii, No. 3, pp. 179-181, March, 1891; vol. xiv, pp. 1-12, July, 1894; vol. xvi, pp. 162-165, September, 1895; and pp. 357-385, December, 1895; Colorado College Studies, Fifth Annual Publication, pp. 49-73, 1894.

‡ Fifth Biennial Report, Kansas State Board of Agriculture, Part II, pp. 132-152, Topeka, 1887.

§ Bull. 57, U. S. Geol. Survey, 1890. Geology and Mineral Resources of Kansas, pp. 12, 13, Topeka, 1893.

|| Proceed. Acad. Nat. Sci., Phila., for 1894, pp. 63-68.

¶ This Journal, vol. i, pp. 205-234, September, 1895.

** Univ. of Kansas Geol. Surv., vol. ii, pp. 96-194, 1897.

†† Hill, this Journal, vol. i, p. 211, 1895.

two members of the Belvidere beds, a lower sandstone member, the Cheyenne sandstone of Cragin,* and an upper shale member, the Kiowa shales of Cragin.† The following description of the general features of the section are taken from Mr. Hill's article in this Journal.

| | |
|--|--------|
| IV. Plains Tertiary | 11 ft. |
| III. Dakota sandstone | 20 " |
| II. Belvidere beds : | |
| <i>b.</i> Kiowa shales, blue and black shales, with fossils | 102 " |
| <i>a.</i> Cheyenne sandstone, gradating up- ward into <i>b.</i> | 71 " |
| I. Red beds | 300 " |

For the details of the section the article by Mr. Hill, previously referred to, Professor Cragin's last contribution to the subject, in the *American Geologist* for December, 1895, and Professor Prosser's report should be consulted.

The Kiowa shales, in which the marine fossils occur, belong to the Washita division of the Comanche Series, as defined by Mr. Hill. The homotaxial relations of the Cheyenne sandstone are as yet indefinite.

There is no necessity for making further notes on the vicinity of Belvidere, so I shall proceed to describe the other localities and outcrops examined.

Outcrops of the Cheyenne sandstone can be seen in Barber County, about five miles from Sun City on the road to Coldwater, where it is light-colored and cross-bedded, contains clay nodules, and weathers into pillars and pinnacles. The contact between the sandstone and the Red Beds was seen at many places, showing that the former rests upon the deeply eroded surface of the latter. Outcrops of the sandstone were occasionally seen on the divide until the descent into the valley of Mule Creek was made. The approximate elevation of the base of the sandstone on the north side of Mule Creek is 1940 to 1960 feet.

Exposures of the Cretaceous occur in Comanche County, about one mile south and five miles east of the village of Nescatunga, around the head of a draw that runs southward into Nescatunga Creek, at an elevation, as judged by the topographic map, between 2020 and 2040 feet. There are several exposures in this vicinity. The easternmost examined consisted of a few feet of very fine-grained pulverulent, stratified, white or pinkish sand, resting unconformably upon the Red Beds. The more western exposures show that the sands

* Bull. Washb. Coll. Lab., vol. ii, No. 10, p. 65, December, 1889.

† Col. Coll. Studies, 5th Ann. Publication, p. 49, 1894.

are overlain by yellow clays, or dark-colored thinly laminated clay shales. In some instances the sands may be indurated so as to form a hard rock.



Map showing position of outcrops of the Comanche Series: outcrops marked by x.

In a sandstone layer in the clays, casts of the following fossils were found*:

- Tapes belviderensis* Cragin?
- Undetermined species of *Cardium*, *Nucula*, and *Corbula*.
- The *Cardium* may be the one identified with *C. kansasense* Meek by Cragin.

* Mr. T. W. Stanton has furnished me notes on the fossils collected.

The following was observed seven and a half miles south of Coldwater, and two and a half miles north of Avilla:

| | |
|--|-------|
| Thin capping of plains gravel. | |
| Yellow clay, with a thin indurated shell layer near the top, in which <i>Gryphæa forniculata</i> White, <i>Cyprimeria</i> cf. <i>texana</i> Roemer, <i>Turritella seriatim-granulata</i> Roemer? and a <i>Cytherea</i> were found..... | 5 ft. |
| A light bluish gray, stiff sandy clay, no fossils..... | 40 " |
| Deep red sandy clay, the Red Beds. | |

The town of Avilla is situated in a valley, on the Red Beds, ten miles south of Coldwater. About seven miles south of Avilla are some hills composed largely of black shales, and locally known as Black Hills. This locality has been referred to by Professor Cragin,* but he has not described it. The details as presented by Professor Prosser† differ slightly from those given in the following description of the section:

| | |
|---|--------|
| Capping of plains gravel. | |
| Calcareous, yellow, sandy flags, and clays; about 10 feet from the top is a bed of <i>Gryphæas</i> intermediate in characters between <i>G. tucumcarii</i> of Marcou and <i>G. forniculata</i> of White, 20 feet from the top large slabs of <i>G. tucumcarii</i> . 40 feet from the top a stratum of oysters and <i>Anomias</i> . | 70 ft. |
| Yellow clay, some thin sandy indurations..... | 35 " |
| Indurated layer containing many <i>Gryphæa forniculata</i> , <i>Turritella seriatim-granulata</i> Roemer?, <i>Cyprimeria</i> , etc., very rich in fossils, about..... | 5 " |
| Paper shales, black..... contain a ledge of brown sandstone 1 ft. thick, 10 ft. above the base. | 45 " |
| Yellowish clays..... | 5 " |
| Contact with the Red Beds—the surface of the latter much eroded; they are composed of deep red somewhat sandy clays. | |

In some places the basal clays of the Cretaceous are mottled, bluish gray and red on a large scale, being composed of the redeposited Red Beds. In one place a patch of shell agglomerate composed of *Gryphæa forniculata* was seen resting directly upon the Red Beds.

The Cretaceous shales were seen in a good many places high up on the divide, south of Avilla, until the descent into the valley of the Cimarron River was made, some twenty miles southeast of that place on the road to Woodward.

* Bull. Washburn Coll. Lab., vol. ii, No. 11, p. 74, March, 1890.

† Prosser, op. cit., p. 142.

Camp Supply Locality.

I was conducted to the following locality by Mr. J. J. Monahan of Camp Supply.

Section of butte, about three miles west of Camp Supply, on the divide between Wolf and Beaver creeks.

Capping of butte, a shell agglomerate composed almost entirely of *Anomia* shells. There are also an elongate delicate species of oyster, and a *Gryphæa* that is difficult to determine, as no good specimen was obtained; it is probably *G. tucumcarii* ----- 6 inches.

Yellow calcareous clays, about ----- 15 ft.

Indurated shell agglomerate, containing

Gryphæa tucumcarii Marcou.

Gryphæa forniculata White, very abundant.

Anomia.

Cyprimeria cf. *texana* Roemer.

Gervillia ?

Cardium.

Turritella seriatim-granulata Roemer ?

Anchura kiowana Cragin ?

Schloenbachia.

Sharks teeth ----- a few inches.

Yellow calcareous clays, resting directly on the Red Beds.

Near the base of this bed is a thin indurated sandy layer that contains many *Turritellas*, some oysters, etc. *Gryphæa forniculata* occurs in the clays below the sandy layer, and was seen in one place resting directly upon the Red Beds ----- 40 ft.

In one place a thinly laminated yellow calcareous sandstone was seen resting on the Red Beds.

Thickness of Red Beds to flat along Wolf Creek ----- 140 "

The Cretaceous was seen at several places on this divide and probably forms a continuous capping.

The localities examined by Professor Cope in this vicinity were on the north side of Beaver Creek, between it and the Cimarron.* He says "Our first object was to examine the red bluffs of Permian or Trias, which bound the cañons north and northwest of the post, which form part of the drainage system of the Cimarron. . . . We found that the formation which constitutes the higher levels at the heads of the cañons tributary to the Cimarron is an impure friable calcareous limestone of evidently lower Cretaceous age." The following is a revised list of the species of mollusks collected by Professor Cope:†

* Proceed. Acad. Nat. Sci., Phila., vol. for 1894, p. 64.

† R. T. Hill, this Journal, vol. 1, p. 227, 1895.

“*Gryphæa forniculata* White.
Exogyra texana Roemer.
Ostrea subovata Shum.
Ostrea quadriplicata Shum. (variety).
Cucullæa terminalis Conrad.
Plicatula incongrua Cragin.
Trigonia emoryi Conrad.
Trigonia sp.
Turritella seriatim-granulata Roem.
Schœnbachia peruvianus von Buch.”

As Professor Cope gives no precise locality for the Cretaceous outcrops, the information furnished by Mr. J. L. Daggitt, a cowboy familiar with the country, may be of interest. He told me that the same kind of a shell bed, that I saw west of Camp Supply, occurred on high places on the divide between Beaver Creek and the Cimarron River on both sides of the Camp Supply and Dodge City, Kansas, cattle trail. The first outcrop is to be seen about five miles north of the former place.

Outcrops in the vicinity of Taloga.

Mr. J. F. Gallup guided me to the localities examined. On the northwest $\frac{1}{4}$, Sec. 9, T. 19 N., R. 17 W. (I. M.) seven miles north and three miles west of Taloga, there are outcrops of a shell agglomerate, 12 to 18 inches thick, and composed almost entirely of the shells of *Gryphæa forniculata* White. Besides these species there are

Gryphæa tucumcarii Marcou, in the same matrix
 with the *G. forniculata*.
Cyprimeria cf. *texana* (Roemer).
Protocardia texana Conrad?
 Three or four other species of undetermined pelecypods.
Turritella seriatim-granulata Roemer.
Schœnbachia peruviana von Buch.
Echinoid plates.

This shell limestone, at the place where it was examined, constituted all there was of the Cretaceous. The outcrops occur along the sides of the draw and were deposited against the sides of the Red Beds hills. They occupy an elevation about 100 feet below the top of the divide, which is composed of Red Beds, overlain by an occasional remnantal patch of Plains gravel. According to the barometer readings the Cretaceous outcrops seemed to be about 100 feet above the South Fork of the Canadian, but they may stand higher. A little higher up the draw along which the above described limestone outcrops occur, is an exposure of stiff chocolate-colored sandy

clay, containing carbonaceous particles and resting against the Red Beds. This clay is probably Cretaceous.

On Section 10 of the same township and range, another outcrop of the shell limestone was seen. Mr. H. G. Springston told me that other outcrops occur on sections 7 and 8 of T. 19 N., R. 17 W.

Marcou's Comet Creek locality.

This locality is especially important because it is the original locality at which Marcou found his *Gryphæa pitcheri*, and is the type locality for his *Neocomian*.

Marcou states "I have mentioned two points between Topofki Creek and Anton Chico where the Triassic rocks are covered by more modern formations. The first of these points is upon one of the tributaries of the False Washita river—Comet Creek (latitude 35° 32' 2"; longitude 99° 14' 40")—near our camp No. 31, where upon the heights are found the remains of beds of a limestone filled with shells, which I connect with the *Neocomian* of Europe, or in other words with the Lower Division of the *Cretaceous Rocks*. This limestone is only five feet thick; it is of a whitish gray color, containing an immense quantity of *Ostracea*, which I consider as identical with the *Exogyra (Gryphæa) Pitcheri* Mort. (Pl. iv, fig. 5, 5a, 5b and 6) having the closest analogy with the *Exogyra Couloni* of the *Neocomian* of the environs of Neuchatel (Switzerland)."^{*} On page 39 of the *Geology of North America*, Professor Marcou gives long. 99°, lat. 35° 50', one of the hills surrounding Comet Creek, as the original locality of his *Gryphæa pitcheri* (not Morton's *G. pitcheri*) = *G. forniculata* (White). There is a discrepancy between these two records of the Comet Creek locality. Marcou's Geological Map of the route† introduces another discrepancy. The following can be obtained from studying what he has written or represented on his map. The locality is not far from Arapaho, it is near the Washita River and is on its northern side. Upon comparing Marcou's map in the Pacific Railroad reports with the present postal route map, it seems very probable that what Marcou called Comet Creek is now known as Barnitz Creek. If Marcou had stated upon which side, east or west, of Camp 31, or upon which side of Comet Creek the locality was, we might be able to rediscover it without great difficulty.

I found eighteen miles north of Arapaho, about two miles south of the D and G county line, an agglomerate composed of *G. forniculata*. Mr. G. T. Dulany, superintendent of schools

^{*} *Geology of N. A.*, p. 17, 1858.

† Vol. iii, Senate Doc., Report Pac. R.R. Expl.

in G. county, directed me to the following locality: about ten miles south of west of Arapaho, Sec. 11, T. 12 N., R. 18 W., on the north side of the Washita River, west of Barnitz Creek. Here there are outcrops of a shell limestone, composed of *Gryphæa pitcheri* Marcou (*G. forniculata* White), imbedded in a matrix of yellow clay, which is often washed out, leaving only shells stuck together. The bed is scarcely two feet thick and forms the tops of small knolls. These patches of the Cretaceous do not occur on the very top of the divide, but on the flanks of the Red Beds hills which rise considerably higher.

Judging from Marcou's map and description, I believe that the above is his original Comet Creek locality. Mr. Dulany informed me that the western bluffs of Panther Creek, south-east $\frac{1}{4}$, Sec. 12, T. 13 N., R. 20 W., 18 miles west and three miles north of Arapaho, are composed of the *Gryphæa* rock. The rock occurs all along the creek from its mouth to its head.

No outcrops of the Cretaceous were found south of Arapaho.

The studies that have been presented in the preceding, show (1) that the Cheyenne sandstone becomes thinner and disappears to the south of Avilla; (2) that the Kiowa shales rest directly upon the Red Beds south of Avilla; (3) that these shales become thinner to the south and are represented in the vicinity of Taloga and Arapaho only by the bed of *Gryphæa forniculata* a few feet thick, now left as patches in a few places; (4) that south of Camp Supply the lower Cretaceous beds do not occupy the tops of the highest divides, but have been deposited on the flanks of the Red Beds hills, thus showing that the country in the vicinity of Arapaho and Taloga was not completely submerged in Lower Cretaceous time. The Wichita Mountain region was, as has previously been shown,* a promontory projecting westward into the Lower Cretaceous sea which sent an arm northward around its western end. The existence of the Wichita promontory may explain the difference between the "Outlying Areas" of the Comanche Series and the main areas in Central Texas. (5) Marcou's *Gryphæa tuumcarii*, asserted by him to be Jurassic, was found in the same matrix with his "Neocomian" *G. pitcheri* (non-Morton) or even in higher beds, thus adding more strength to the chain of evidence by which his "Jurassic" has been proven not only not Jurassic, but that it belongs to Cretaceous beds above his so-called *Neocomian*, which is far above the base of the American Cretaceous.

Washington, D. C.

* Hill, this Journal, vol. 1, p. 229, September, 1895.

ART. VIII.—On *Electrosynthesis*; by W. G. MIXTER.

[Contributions from the Sheffield Laboratory of Yale University.]

THE action of the electric current on compounds, as is well known, usually decomposes them whether they are in solution, in the molten or gaseous state. As an example of the last we have the electrolysis of steam* with the separation of hydrogen and oxygen equal to the volume of these gases evolved by the same current through dilute sulphuric acid that passes in sparks through the steam. The heat of the sparks also decomposes the steam, but this has not prevented the determination of the electrolytic results. Some physicists consider that the molecules of simple as well as compound gases are decomposed by the electrical discharge and that free atoms, or ions, carry the electricity. If this is true, then the primary effect of electricity may be solely electrolytic and the synthetic results may be due to combinations of free ions. Without discussing this now, let it be understood that the term *electrosynthesis* is applied in this paper to chemical union effected by means of electricity, not, however, by the heat of the discharge. Ammonia, nitric acid, and a few other compounds have been produced in small quantities by the action of electricity, and recently Losanitsch and Jovitschitsch† have made an important addition to our knowledge of *electrosynthesis*. Their results may be indicated by the equations $H_2O + CO = HCOOH$, $CO_2 + H_2O = HCOOH + O$, $CO + H_2 = CH_2O$, $CO_2 + H_2 = HCOOH$, $CO + CH_4 = CH_3CHO$. They state that the dark discharge (*dunkle Entladung*) effects synthesis only, but my observations are that a feeble glow visible only in a dark room causes decomposition as well as combination.

Early last year I observed that feeble sparks in an ozonizing tube with an inner conducting wire did not cause an explosion of acetylene gas under a pressure at which it exploded promptly when the ordinary spark was passed through it. This led to experiments with various forms of electrical discharge in a mixture of two volumes of hydrogen and one of oxygen. It was found that such a mixture at a pressure of 235^{mm} was not exploded in an ozonizing tube, by sparks visible in daylight and giving a distinct snapping noise. The combination was slow. At the pressure given the mixed gases are exploded by the ordinary electric spark, while, as is known, they do not

* J. J. Thomson: *Recent Researches in Electricity and Magnetism*, pp. 181 and 559.

† Ueber chemische Synthesen mittels der dunkler elektrischen Entladung, *Ber. d. deutsch. chem. Gesellsch.*, xxx, 135.

explode when under a pressure of 70^{mm} or less. Dixon* found that a mixture of cyanogen and oxygen exhibits a similar deportment and that it is exploded by a strong but not by a feeble spark. Hautefeuille and Chappius† state that hydrogen is indifferent when oxygen is ozonized, and Berthelot‡ found that two volumes of hydrogen and one of oxygen did not combine under the influence of the current (*l'effleuve*) and that ozone was formed. These observations do not

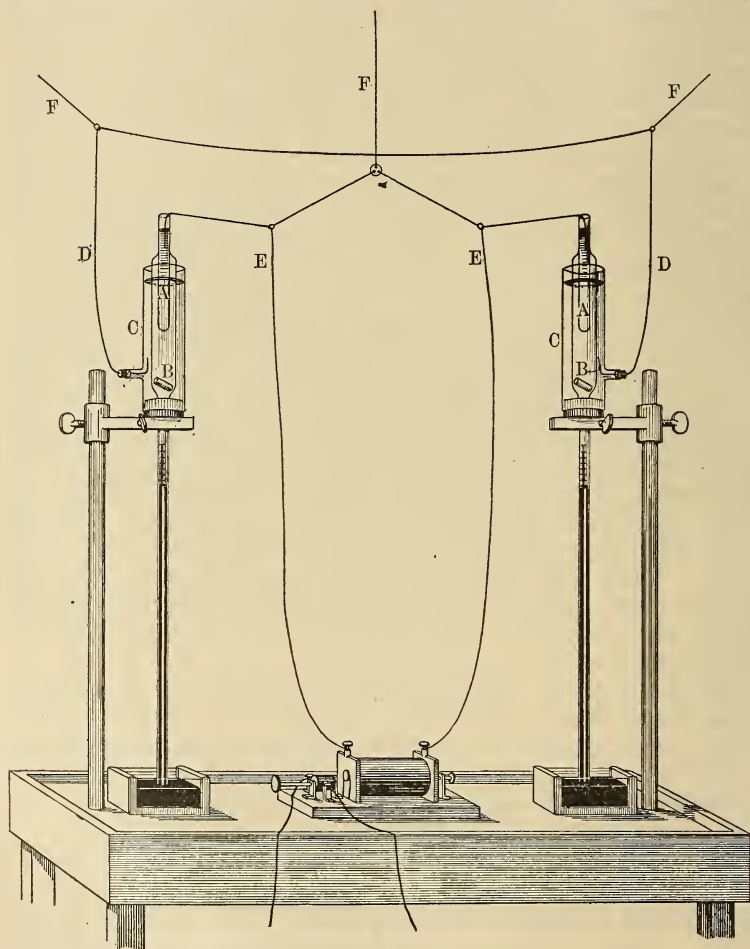

accord with mine and the different results may be due to different conditions of experiment. The glow discharge in the apparatus described later causes the slow combination of hydrogen and oxygen, during which very little ozone is formed.

* Jour. Chem. Society, xlix, 384.

† Comptes Rendus, xci, 522, 762.

‡ Ann. Chim. et Phys., [5], xvii, 142.

After trying various forms of apparatus, that shown in the figure was adopted. The wires E from the induction coil dip into the tap water in the inner tubes A and the tap water in the jacket tubes C is connected by the insulated wire D. The wires are supported by the insulating cords F, and the standards and clamps are of wood. The eudiometers are placed about three feet apart, it having been found when they were only a few inches apart that an electrical discharge in one sometimes produced a glow in the other from which the conducting wires were removed, and when close together and in series that the results were discordant. Experience also showed that it is necessary to let the apparatus stand some hours before commencing an experiment. A current of 2.2 volts and 1 to 1.6 amperes from one storage cell was used on the primary of the coil, giving a spark in air of 7 to 10 millimeters and of course a much feebler current through the wire D. A current of higher potential discharged perceptibly into the air from the wires E. Two cells were used and the coil was connected at times with only one eudiometer to complete the reaction in order to find the residual gas not entering into combination. The gases were dried by solid potassium hydroxide at B. To absorb carbon dioxide half to one cubic centimeter of a saturated solution of potassium hydroxide was introduced and made to coat the eudiometer four or five centimeters above B. The vapor tension of the solution was too small to interfere with the results. The absorption of water and carbon dioxide was so rapid while the discharge was taking place in the eudiometers that only one or two per cent of the volume of the gases was water or carbon dioxide or both together. This was found by reading the eudiometer when the current from the coil was stopped and again some hours later. With gases at a pressure of 150^{mm} or less a glow about the tube A, visible only in a darkened room, usually appeared on putting the coil in action, while in some cases a stronger current than that described was required to start the glow discharge, but when once started the feeble current gave a fairly constant glow. The discharge between the glass surfaces in the eudiometers was of course alternating and so was the current in the connecting wires and hence not measurable by electrolytic methods. Many experiments were made with the discharge from large metallic electrodes in oxygen and hydrogen at low pressures. Sometimes there was slow combination, but usually the mixture exploded, and hence attempts to use the direct discharge were abandoned. A Wimshurst machine was also tried without success. When connected with the eudiometers described they appeared to act as condensers, the discharge in them being alternating. At some future time I hope to measure the current by electrical methods and to determine the quantity of

electricity causing the combination of gases, and also to determine the conductivity of gases when uniting. Thus far in the work an empirical measure has been used which is the amount of oxygen and hydrogen combining in one eudiometer while gases in the other eudiometer also combined, the same current passing through both eudiometers. The mixture of hydrogen and oxygen used in all of the work was obtained by the electrolysis of dilute sulphuric acid. The following experiments with hydrogen and oxygen in both eudiometers were made to test the method. The reduced volume is calculated for 0° C. and 760^{mm} pressure. The time of the action of the current is given in hours in the column on the left.

| Eudiometer No. 3. | | | | | | Eudiometer No. 1. | | | | | |
|-------------------|-------|---------------|------------------|-----------------|------------------------|------------------------|-----------------|------------------|-----------|-------|--|
| Hours. | Temp. | Pressure. | Observed volume. | Reduced volume. | c. c. of gas combined. | c. c. of gas combined. | Reduced volume. | Observed volume. | Pressure. | Temp. | |
| | 14.5 | 1.3 | 121 | 0.2 | | | 0.02 | 118 | 0.1 | 14.5 | |
| | 16.6 | 190.5 | 152.7 | 36.1 | | | 34.8 | 146.8 | 191.1 | 16.4 | |
| 1 | 16.6 | 177.5 | 150.5 | 33.1 | 3 | 3.7 | 31.1 | 144.3 | 173.5 | 16.6 | |
| 1 | 16.6 | 161.5 | 148.1 | 29.7 | 3.4 | 4.1 | 27 | 141.6 | 153.5 | 16.6 | |
| 1 | 17 | 147 | 145.8 | 26.6 | 3.1 | 4 | 23 | 138.7 | 134 | 17 | |
| * | | | | | | | | | | | |
| | 13.6 | 132.8 | 142.4 | 23.7 | | | 22.6 | 137.3 | 131.3 | 13.4 | |
| 1 | 14.6 | 119.5 | 140.4 | 21 | 2.7 | 3 | 19.6 | 135.1 | 116 | 14.6 | |
| 1 | 13.6 | 103.5 | 137 | 17.8 | 3.2 | 3.1 | 16.5 | 132 | 99.5 | 13.6 | |
| 1 | 13.6 | 85 | 134 | 14.3 | 3.5 | 3.4 | 13.1 | 129.2 | 81 | 13.6 | |
| 1 | 11.6 | 64.5 | 131 | 10.7 | 3.6 | 3.5 | 9.6 | 126.3 | 60.5 | 11.6 | |
| 1 | 12 | 47 | 127.9 | 7.6 | 3.1 | 3.1 | 6.5 | 123.5 | 42 | 12 | |
| 1 | 12.6 | 33.3 | 126.1 | 5.3 | 2.3 | 2.2 | 4.3 | 121.4 | 27.9 | 12.6 | |
| 1 | 13.6 | 20 | 124 | 3.1 | 2.2 | 2.1 | 2.2 | 119.5 | 15 | 13.5 | |
| | | | | | 30.1 | 32.2 | | | | | |
| | 14 | Residual gas. | 121.6 | 0.61 | | | 0.58 | Residual gas. | 4 | 14 | |

| Eudiometer No. 3. | | | | | | Eudiometer No. 1. | | | | | |
|-------------------|-------|---------------|------------------|-----------------|------------------------|------------------------|-----------------|------------------|-----------|-------|--|
| Hours. | Temp. | Pressure. | Observed volume. | Reduced volume. | c. c. of gas combined. | c. c. of gas combined. | Reduced volume. | Observed volume. | Pressure. | Temp. | |
| | 14 | 224.5 | 156.5 | 44 | | | 43 | 151.2 | 226.8 | 14 | |
| 1 | 14 | 204.8 | 153.6 | 39.4 | 4.6 | 4.7 | 38.3 | 148.4 | 206.3 | 13.8 | |
| 1 | 15.7 | 188 | 151.2 | 35.4 | 4 | 4.1 | 34.2 | 145.9 | 188.5 | 15.7 | |
| 1 | 17 | 172 | 144.8 | 31.7 | 3.7 | 3.5 | 30.7 | 143.7 | 172.5 | 17 | |
| 1 | 17 | 158.4 | 146.4 | 28.7 | 3 | 3 | 27.7 | 141.3 | 158.2 | 17 | |
| 1 | 17 | 141.1 | 143.1 | 25 | 3.7 | 3.6 | 24.1 | 138.0 | 141.1 | 17 | |
| 1 | 17.4 | 118.2 | 139 | 20.4 | 4.6 | 4.5 | 19.6 | 134.9 | 117.2 | 17.4 | |
| 1 | 17.9 | 97.4 | 136.1 | 16.4 | 4 | 3.9 | 15.7 | 131.6 | 96.8 | 17.9 | |
| 1 | 18 | 74.5 | 132.8 | 12.2 | 4.2 | 3.8 | 11.9 | 128.6 | 74.8 | 17.8 | |
| 1 | 18 | 55.5 | 129.6 | 8.9 | 3.3 | 3.3 | 8.6 | 125.6 | 55.3 | 18 | |
| 1 | 18 | 37.5 | 126.8 | 5.9 | 3 | 2.9 | 5.7 | 122.9 | 37.5 | 18 | |
| 1 | 16.6 | 20.5 | 124.8 | 3.2 | 2.7 | 2.4 | 3.3 | 121 | 22.2 | 16.6 | |
| | | | | | 40.8 | 39.7 | | | | | |
| | 15 | Residual gas. | 120.6 | 0.72 | | | 0.70 | Residual gas. | 4.8 | 15 | |

* Passed the current through 3 only for a time to equalize the pressure, then through both for a few minutes and observed the volume later.

The eudiometers were filled with gas for the second experiment without removing the residual gas of the first, namely 0.61 and 0.58^{cc} and the increase of 0.1^{cc} of residual gas in the second experiment shows that almost no ozone was formed. Moreover, the mercury was only slightly tarnished. During half of the time of the first experiment the current was reversed in the primary of the coil with no marked difference in the relative rate of combination in the two tubes. The direction of the current was not changed in the second experiment. The lack of uniformity in the results from hour to hour is only in small part due to errors of observation and is probably owing to leakage of electricity from the wires or its passage over the surface of the glass above the jacket tubes. The marked discrepancies during the first three hours of the first experiment show the liability to error in the method. Leaving out these hours, the results accord fairly and the total amount of combination is 20.6^{cc} and 20.4^{cc} respectively.

It will be observed that the gases in the two tubes were under nearly equal pressures. This is essential, for the higher the pressure the more rapid the combination as shown by the following: the results in each horizontal line were by the same current acting on a hydrogen-oxygen mixture in two eudiometers.

| c. c. combined. | Mean pressure. | c. c. combined. | Mean pressure. |
|-----------------|-------------------|-----------------|------------------|
| 6.22 | 133 ^{mm} | 3.87 | 73 ^{mm} |
| 5.42 | 160 | 4.39 | 110 |
| 21.95 | 186 | 13.3 | 91 |
| 14.43 | 81 | 11.25 | 76 |

The reason for these results is not apparent and the rate of combination bears no simple relation to the pressure.

Vapor of water, as already mentioned, is electrolyzed by the spark discharge, and it is also dissociated by the feeble glow discharge. Three experiments made with the vapor at low pressures in apparatus like that figured gave small volumes of permanent gas. Hence it may be that some of the water from the oxidation of hydrogen is decomposed, but it is probable that little if any is decomposed in a mixture of gases in which water is constantly forming and which contains on account of rapid drying a very small proportion of water.

In order to determine the ozonizing effect on pure oxygen of the glow discharge, one eudiometer was filled with 36^{cc} (reduced to 0° and 760^{mm}) of oxygen at 193^{mm} pressure and the other eudiometer with 30.6^{cc} of hydrogen and oxygen. A saturated solution of potassium hydroxide and iodide was put into each eudiometer to dry the gases and absorb ozone. A current from two storage cells on the primary of the coil was used for an hour and a half. The oxygen contracted 0.3^{cc}, and

the hydrogen-oxygen mixture 11.2^{cc} (reduced to 0° and 760^{mm}). The light in the oxygen was much feebler than in oxygen and hydrogen. The current was next passed through the oxygen only for two hours and the contraction was 2.2^{cc}.

Carbonic Oxide and Oxygen.

The carbonic oxide used was made by heating a mixture of formic acid and oil of vitriol. Two measures of the gas were mixed over water with one measure of oxygen from pure potassium chlorate. The mixed gases left after exploding and treating with potassium hydroxide less than 1 per cent of gas. The following table contains the observations and results of four experiments.

| Hydrogen, 2 volumes. Oxygen, 1 " | | | | | | Carbonic oxide, 2 volumes. Oxygen, 1 " | | | | |
|-------------------------------------|-------|----------------|---------------------|--------------------|-----------------------------------|---|--------------------|---------------------|----------------|-------|
| Hours. | Temp. | Pres- sure. | Observed volume. | Reduced volume. | c. c. of gas com- bined. | c. c. of gas com- bined | Reduced volume. | Observed volume. | Pres- sure. | Temp. |
| 2 | 16 | 180.5 | 144.9 | 32.5 | 6.6 | 7.9 | 33.2 | 148.1 | 180.5 | 16 |
| | 14.5 | 147.5 | 140.7 | 25.9 | | | 25.3 | 144.4 | 140 | 14.5 |
| 5 | 15.8 | 179.8 | 140 | 31.3 | 20.6 | 21.1 | 33.3 | 145 | 184.7 | 15.8 |
| | 16.6 | 69.5 | 124.3 | 10.7 | | | 12.2 | 128 | 77.5 | 16.2 |
| 5 | 15.9 | 186 | 148.7 | 34.4 | 18.6 | 22.3 | 32 | 144.5 | 178.1 | 16.2 |
| | 18 | 94 | 135.9 | 15.8 | | | 9.7 | 121.3 | 65 | 18.3 |
| 2 | 17 | 1.5 | 121.3 | 0.2 | 7 | 8.4 | 0.5 | 118 | 3.5 | 17 |
| | 16.4 | 188 | 150 | 35 | | | 39.2 | 149.6 | 211 | 16.4 |
| 2 | 16 | 153 | 147.3 | 28 | 7.3 | 9.2 | 30.8 | 146 | 170 | 16.5 |
| 2 | 14.7 | 117.8 | 140.8 | 20.7 | 6.8 | 7.2 | 21.6 | 138.4 | 124.8 | 14.7 |
| 2 | 15.8 | 82.6 | 135 | 13.9 | 9.5 | 10.2 | 14.4 | 132 | 87.6 | 15.6 |
| 2 | 16 | 28.2 | 125 | 4.4 | 30.6 | 35 | 4.2 | 122.7 | 27.2 | 16 |
| | 20 | 3.2 | 122.4 | 0.5 | | | 0.6 | 119 | 4.2 | 18 |

In the last experiment the air in the eudiometers, 0.2 and 0.5^{cc}, was noted before filling with the gases, and also the residual gas, 0.5 and 0.6^{cc}, when the electric discharge gave no further rise of the mercury in the tubes. The hydrogen-oxygen mixture was in one eudiometer in the first and third experiments and in the other eudiometer in the second and fourth; that is, the arrangement and filling of the apparatus was reversed each time after the first experiment. In all 76.4^{cc} of hydrogen and oxygen and 86.3^{cc} of carbonic oxide and oxygen combined, a ratio of 1 to 1.13.

Glow Discharge in dry Carbonic Oxide and Oxygen.

The eudiometers were filled with a mixture of two volumes of carbonic oxide and one volume of oxygen, the same mixture

as used in the preceding experiments, and phosphorus pentoxide was put into the eudiometers to dry the gases. The apparatus was allowed to stand for two days and then the glow discharge was passed for two hours. The contraction in volume caused by the discharge was in each case 2.5^{cc} , reduced to 0° and 760^{mm} pressure. The initial volumes were 13.1^{cc} and 18.5^{cc} respectively. The results show that dry carbonic oxide and oxygen slowly combine when acted upon by the glow discharge.

Methane and Oxygen.

The methane was made from methyl iodide by the action of zinc and alcohol. For the following experiments one volume of methane and two volumes of oxygen were mixed over water.

| Hydrogen, 2 volumes. Oxygen, 1 " | | | | | Methane, 1 volume. Oxygen, 2 " | | | | | |
|-------------------------------------|-------|-----------|------------------|-----------------|-----------------------------------|------------------------|-----------------|------------------|-----------|-------|
| Hours. | Temp. | Pressure. | Observed volume. | Reduced volume. | c. c. of gas combined. | c. c. of gas combined. | Reduced volume. | Observed volume. | Pressure. | Temp. |
| | 15 | 13 | 117 | 1.9 | | | 0.8 | 120 | 5 | 15 |
| | 14.3 | 164.5 | 119 | 24.5 | | | 28.2 | 143 | 157.5 | 14.3 |
| 2 | 15.5 | 129.5 | 118.5 | 19.1 | 5.4 | 7.1 | 21.1 | 139 | 121.5 | 15.2 |
| 2 | 16.4 | 90.5 | 117 | 13.1 | 6 | 9 | 12.1 | 131 | 74.5 | 16 |
| 2 | 18 | 51 | 116.5 | 7.3 | 5.8 | 9.5 | 2.6 | 123 | 17 | 18 |
| | 24 | 21 | 116 | 2.9 | | | 1.5 | 122 | 10 | 19 |
| | | | | | 17.2 | 25.6 | | | | |
| | 17 | 4.5 | 119.5 | 0.7 | | | 1 | 117 | 7 | 17 |
| | 13.3 | 192.5 | 148.7 | 35.9 | | | 30.2 | 120 | 200.5 | 13.3 |
| 2 | 14 | 159.5 | 144.3 | 28.8 | 7.1 | 9.9 | 20.3 | 119 | 136.5 | 14.4 |
| 2 | 15.6 | 122.5 | 138.4 | 21.1 | 7.7 | 11.1 | 9.2 | 118 | 63.5 | 16 |
| | 17 | 4.8 | 120 | 0.7 | | | 2.7 | 117 | 19 | 18.8 |
| | | | | | 14.8 | 21 | | | | |
| | 14 | 1.5 | 120 | 0.2 | | | 0.4 | 116 | 3 | 14 |
| | 16 | 203 | 129 | 32.6 | | | 34.7 | 144.5 | 193 | 16 |
| 2 | 17.1 | 161.5 | 126 | 25.2 | 7.4 | 10.3 | 24.4 | 137.3 | 143.5 | 17.3 |
| 2 | 16.4 | 111 | 122.5 | 16.9 | 8.3 | 11 | 13.4 | 127 | 85 | 16.6 |
| | 19 | 2 | 117 | 0.3 | | | 3.9 | 118.5 | 26.5 | 17 |
| | | | | | 15.7 | 21.3 | | | | |

The eudiometers in the first experiment contained 1.9^{cc} and 0.8^{cc} of air and the residual gases at the end of the test were 2.9^{cc} and 1.5^{cc} respectively when the battery gave out. The result shows that the methane and oxygen combined according to the equation

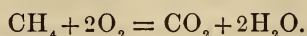

In the second experiment the residual gas, after the discharge ceased to cause a diminution of volume in the methane-oxygen mixture, was 2.7^{cc} , while in the last experiment the residual gas

was 3.9^{cc} and was found to be chiefly oxygen. This excess of oxygen may be due to leakage of the mixed gases from the gas-holder during the time intervening between the first and last experiment. In the three experiments 47.7^{cc} of hydrogen and oxygen and 67.9^{cc} of methane and oxygen combined, or in the ratio of 1 to 1.42. The ratio in the successive experiments is 1 to 1.49, 1 to 1.43, and 1 to 1.36. The smaller ratios for methane and oxygen in the last two are explained by the presence of an excess of oxygen.

Ethylene and Oxygen.

The ethylene used was made from ethylene bromide by means of a zinc-copper couple and was nearly pure.

| Hydrogen, 2 volumes. Oxygen, 1 " | | | | | | Ethylene, 5.2 c. c. Oxygen, 19.1 c. c. | | | | | |
|-------------------------------------|-------|----------------|---------------------|--------------------|-----------------------------------|---|---|---------------------|----------------|-------|------|
| Hours. | Temp. | Pres- sure. | Observed volume. | Reduced volume. | c. c. of gas com- bined. | c. c. of gas com- bined. | Reduced volume. | Observed volume. | Pres- sure. | Temp. | |
| 2 | 12.8 | 126.5 | 138 | 22 | 5.6 | 12.4 | 24.3 | 138 | 140 | 13.3 | |
| | 13.7 | 97.5 | 134 | 16.4 | | | 11.9 | 128 | 74 | 14 | |
| 2 | 16 | 131 | 137 | 22.3 | 10 | 18.5 | *6 | 124 | 39 | 18 | |
| | | | | | | | Ethylene, 1 volume. Oxygen, 3 volumes. | | | | 25.3 |
| | 13 | 76 | 129 | 12.3 | | | 6.8 | 126 | 43 | 13 | |
| | | | | | | | *5.2 | 125 | 33 | 14 | |
| 1 | 16.6 | 101.8 | 137.5 | 17.4 | 4.1 | 12.5 | Ethylene, 1 volume. Oxygen, 2.5 volumes. | | | | |
| | 17 | 80 | 134 | 13.3 | | | 21.1 | 140 | 121.3 | 16 | |
| 1 | 16.8 | 82 | 131 | 13.3 | 3.5 | 10.7 | 8.6 | 130.5 | 53 | 16.6 | |
| | 17.8 | 62 | 128 | 9.8 | | | *6.7 | 124 | 4.7 | 20 | |
| 1 | 16.8 | 82 | 131 | 13.3 | 3.5 | 10.7 | 19.1 | 136 | 113 | 16.2 | |
| | 17.8 | 62 | 128 | 9.8 | | | 8.4 | 128 | 53 | 17.8 | |

Three volumes of oxygen are required for the complete oxidation of one volume of ethylene, but in none of the experiments was the gas all oxidized to carbon dioxide and water. In the first experiment with an excess of oxygen 2.5 volumes disappeared to one of ethylene. The residual gas, 5.2^{cc}, of the second experiment was found to be oxygen. The combination of ethylene and oxygen in the third was very nearly in the proportion of 1 to 2.5 volumes. Doubtless some acetic acid was formed, as no oxalic or formic acid was found in an experiment made especially to determine whether these acids were formed. The results of the second experiment except as above

* Residual gas.

stated are worthless, because the action of the discharge was not stopped until the ethylene was nearly all consumed and there was a large excess of oxygen present. The first experiment shows a ratio of the hydrogen and oxygen consumed in two hours to ethylene and oxygen of 5.6 to 12.4^{cc} or as 1 to 2.2, while in the last two the ratio is 1 to 3. The slower rate of combination of ethylene and oxygen in the first case is to be ascribed to the excess of oxygen present.

Acetylene and Oxygen.

The acetylene used in the following experiments was made from calcium carbide and kept over water. It proved to be nearly pure.

| Hydrogen, 2 volumes. Oxygen, 1 " | | | | | | Acetylene, 4.8 c. c. Oxygen, 15.7 c. c. | | | | | |
|-------------------------------------|-------|----------------|---------------------|--------------------|-----------------------------------|--|----------------------|---------------------|----------------|-------|--|
| Hours. | Temp. | Pres- sure. | Observed volume. | Reduced volume. | c. c. of gas com- bined. | c. c. of gas com- bined. | Reduced volume. | Observed volume. | Pres- sure. | Temp. | |
| 1 | 17.4 | 121 | 139 | 20.8 | 3.8 | 11 | 20.5 | 137 | 121 | 17.4 | |
| | 15.2 | 101 | 135 | 17 | | | 9.5 | 129 | 59 | 15.2 | |
| | | | | | | | 3.3 | 123 | 22 | 19 | |
| 1 | 10.5 | 100 | 136 | 17.2 | 4.8 | 13.1 | Acetylene, 6.3 | c. c. | | | |
| | 14 | 74.5 | 133 | 12.4 | | | Oxygen, 17.7 | c. c. | | | |
| | | | | | | | 24 | 140.5 | 135 | 10.5 | |
| 1 | 16.2 | 124.4 | 140 | 21.6 | 4.3 | 13.9 | Acetylene, 8.2 | c. c. | | | |
| | 16.2 | 101.7 | 137 | 17.3 | | | Oxygen, 18.4 | c. c. | | | |
| | | | | | | | 26.6 | 142 | 151 | 16 | |
| 1 | 16.5 | 133 | 139 | 22.9 | 4.6 | 14.6 | Acetylene, 1 volume. | | | | |
| | 15.4 | 108.7 | 135.4 | 18.3 | | | Oxygen, 2.5 volumes. | | | | |
| | | | | | | | 26.7 | 142 | 152 | 17 | |
| | | | | | | | 12.1 | 131 | 74 | 15.4 | |
| | | | | | | | 0.7 | 123 | 4.7 | 18 | |

In the first experiment the oxygen consumed was 15.7—3.3 = 12.4 or 2.58 times the acetylene taken. In the last experiment the acetylene and oxygen were in the proportion required for complete oxidation of the former, and of the 26.7^{cc} of gases taken only 0.7^{cc} remained. The results show that acetylene in presence of sufficient oxygen is all converted into carbon dioxide and water by the glow discharge. 2.9, 2.7, 3.2, and 3.2 cubic centimeters respectively of acetylene and oxygen combined to 1 of hydrogen and oxygen. The lower results in the first two are evidently due to the excess of oxygen present in the mixtures.

Ethane and Oxygen.

The ethane used in the following experiment was made from ethyl iodide by the action of the zinc-copper couple in alcohol. The ethane and oxygen were measured in the eudiometers.

| Hydrogen, 2 volumes. Oxygen, 1 " | | | | | | Oxygen, 18·8 c. c. Ethane, 5 c. c. | | | | |
|-------------------------------------|-------|-----------|------------------|-----------------|------------------------|---------------------------------------|--------------------|------------------|-----------|-------|
| Hours. | Temp. | Pressure. | Observed volume. | Reduced volume. | c. c. of gas combined. | c. c. of gas combined. | Reduced volume. | Observed volume. | Pressure. | Temp. |
| | 17 | 115 | 136 | 19·4 | | | 23·8 | 139 | 138 | 17 |
| 1 | 16 | 93 | 133 | 15·4 | 4 | 8·9 | 14·9 | 132 | 91 | 16 |
| 1 | 18 | 68 | 129 | 10·8 | 4·6 | 6·4 | 8·5 | 127 | 54 | 18 |
| | | | | | | | 7·5 | 126 | 48 | 18 |
| | | | | | 8·6 | 15·3 | | | | |
| | | | | | | | Oxygen, 16·6 c. c. | | | |
| | | | | | | | Ethane, 8 c. c. | | | |
| | 17 | 113·5 | 136 | 19·1 | | | 24·6 | 139 | 143 | 17 |
| ½ | 17 | 103·5 | 135 | 17·3 | 1·8 | 2·6 | 22 | 137 | 129·5 | 17 |
| 1 | 15·6 | 79·5 | 132 | 13·1 | 4·2 | 7 | 15 | 132 | 91 | 15·6 |
| 1 | 16·6 | 55 | 130 | 8·9 | 4·2 | 6 | 9 | 127 | 57 | 16·6 |
| | | | | | | | 1·2 | 120 | 8 | 18 |
| | | | | | 10·2 | 15·6 | | | | |
| | | | | | | | Oxygen, 13·5 c. c. | | | |
| | | | | | | | Ethane, 8·5 c. c. | | | |
| | 17·6 | 128 | 137 | 21·7 | | | 22 | 138 | 129 | 17·6 |
| 1 | 16·8 | 106 | 134 | 17·6 | 4·1 | 5·9 | 16·1 | 134 | 97 | 17 |
| 1 | 14·6 | 82 | 133 | 13·6 | 4 | 6·4 | 9·7 | 131 | 59 | 14·8 |
| | | | | | | | 4·7 | 123 | 31 | 17 |
| | | | | | 8·1 | 12·3 | | | | |

One volume of ethane, C_2H_6 , requires for complete combustion $3\frac{1}{2}$ volumes of oxygen. In the experiments, however, less than $2\frac{1}{2}$ were consumed. In the first, 5^{cc} of ethane and $11·3^{cc}$ of oxygen ($18·8^{cc}$ less $7·5^{cc}$ residual oxygen) combined, and in the second 8^{cc} and $15·4^{cc}$ ($16·6 - 1·2$). The oxidation was stopped in the third experiment when $9·7^{cc}$ remained, and the oxygen in the mixed gases was found to be 5^{cc} , leaving $4·7^{cc}$ per cent ethane. Deducting these numbers from the volumes of gases originally taken, we find that $3·8^{cc}$ of ethane and $8·5^{cc}$ of oxygen combined; $1·8$, $1·5$ and $1·5$ cubic centimeters respectively of ethane and oxygen combined to 1 of hydrogen and oxygen. The rate of combination was most rapid in the first with an excess of oxygen present, and during the first hour was 2·2 times that of the hydrogen-oxygen mixture, while in the second hour it was much less owing to the large excess of oxygen present.

Molecular Changes.

The table below is based on the composition of the gases used and the ratio of the volumes combined to one volume of hydrogen and oxygen also combined under the influence of the glow discharge as before described. The ratio taken for carbonic oxide and oxygen is 1.13, the mean of all the results; for methane and oxygen 1.49, which appears to be the best result; for ethylene and oxygen 3, the result of the last two experiments with these gases; for acetylene and oxygen 3.2; and for ethane and oxygen 1.5. The volume ratios also represent the relative number of molecules combining, and for convenience these ratios are given in the table in whole numbers, and one volume of hydrogen and oxygen is assumed to contain 100 molecules.

| Mixture of gases. | Molecules combined. | Molecules oxidized. | Molecules of oxygen consumed. | |
|----------------------------|---------------------|-------------------------------|-------------------------------|-----|
| Hydrogen and oxygen, | 100 | H ₂ | 67 | 33 |
| Carbonic oxide and oxygen, | 113 | CO | 75 | 38 |
| Methane | 149 | CH ₄ | 49 | 100 |
| Ethylene | 300 | C ₂ H ₄ | 86 | 214 |
| Acetylene | 320 | C ₂ H ₂ | 91 | 229 |
| Ethane | 150 | C ₂ H ₆ | 50 | 100 |

The accuracy of the experimental work is by no means what is desirable, nevertheless it is evident that the same electric current caused the oxidation of a different number of molecules of the gases, the variation being as 1 to 2, while the oxygen consumed varied as 1 to 7 molecules. Moreover, the numbers representing the relative proportions of the molecules oxidized fall into two classes, viz: 67, 49, 50, and 75, 86, 91. The former are the numbers of saturated and the latter of unsaturated molecules oxidized. Ethylene and acetylene differ but little in deportment, although the latter is the more endothermic in character. Both combine more rapidly than carbonic oxide; methane and ethane combine at about the same rate but slower than hydrogen. If we calculate the amount of change in a mixture of hydrogen and oxygen on the basis that 3.6^{cc} combine in one hour, we find that 1 cubic millimeter of the mixture unites in a second. The space occupied by the glow discharge in the apparatus was about 30^{cc}, and the volume of gas at $\frac{1}{10}$ th of an atmosphere equals 3000 cubic millimeters at standard pressure, that is, the molecules combining during one second were mixed with 3000 times as many molecules. This slow combustion did not raise the mean temperature of the gases, as the heat evolved was constantly lost by radiation. Whether the energy of oxidation induced by the electric glow

also causes chemical union, it is impossible to say. It seems, however, safe to assume that the heat energy plays little part in effecting chemical change for the reason that the heat of combustion increases in the series tabulated much faster than the number of molecules combining. We shall be sufficiently accurate in assuming the heats of combustion to be proportional to the oxygen consumed. For example, the oxidation of three molecules of acetylene gives seven times as much heat as one molecule of hydrogen. Further, if the energy resulting from the union caused by electricity of two molecules of hydrogen and one molecule of oxygen causes other molecules to combine, we should expect the energy of this phase of combination to cause further combination and rapid combustion or an explosion. If then the chemical changes in the mixed gases tested were not caused in part by heat, it remains to consider the nature of the change caused by electricity. Oxidation was not effected by ozone nor preceded by its formation, as the discharge was too feeble to produce sufficient ozone to account for the amount of oxidation. Moreover, hydrogen, carbonic oxide and methane resist ozone. The hydrocarbons also were but slightly decomposed by the glow discharge, as the following experiments show. 8.85^{cc} of methane, subjected to the discharge for an hour and a half, increased in volume 0.28^{cc} with formation of acetylene. The change may be expressed by the equation



That is, four volumes of methane yield eight volumes of gas. A similar test of 23.8^{cc} of ethane for an hour gave 0.4^{cc} increase in volume; only a small quantity of acetylene was formed. The reaction is



That is, two volumes of ethane yield six volumes of gas. The decomposition of the hydrocarbons by the discharge is, therefore, too slight to account for the amount of change in the mixtures of oxygen. This fact and the non-formation of ozone indicate that the formation of water and carbon dioxide was not due to the union of ions, a view supported by the syntheses by Losanitsch and Jovitschitsch* of organic compounds. If chemical union in the cases discussed is not to be explained by the ion theory, we may infer that the glow discharge of electricity renders molecules chemically active and capable of interacting. We may thus consider the molecular changes involved in electrosynthesis to be analogous to those occurring in synthesis effected by heat or light where combination takes place at a temperature far below that at which the gaseous molecules dissociate.

* Loc. cit.

ART. IX.—*Monazite from Idaho*; by W. LINDGREN.

THE intermontane valley of "Idaho Basin" is situated thirty miles north-northeast of Boise City, Idaho, in the great granite area of the southern part of that state. Its placer mines have been of extraordinary richness and still contribute a considerable proportion of the gold production of Idaho. The gold-bearing gravels are of Pleistocene and Neocene age and, near Idaho City, there are also some Neocene lake beds containing only a slight amount of gold.

The sand of the gravels and lake beds of the Idaho basin is entirely derived from the granite and associated dike rocks. It consists of relatively angular and sharp-edged grains indicating its manner of formation by extremely rapid accumulation from the deeply disintegrated rocks.

In all parts of the basin a yellow or brownish yellow mineral forms a considerable quantity of the heavy substances remaining with the gold. The mineral has been shown to be monazite, this being the first time its occurrence has been noted from the western states. As well known, it occurs abundantly in the granite and gneissoid rocks and gold placer mines of the Southern Appalachians and in several of the northern Atlantic states, also in Brazil, the Ural Mountains and other places. There is no doubt it forms an original constituent of the granite of the Idaho Basin.

A sample washed from the lake beds near Idaho City consisted of the following minerals: ilmenite in sharp hexagonal crystals but no magnetite; zircon, also in extremely sharp crystals of a slightly brownish color; and abundant yellow or greenish yellow grains rarely showing crystallographic faces; the refraction and double refraction of this mineral were very high, the hardness not much over 5. The ilmenite was eliminated by the electro-magnet and the remaining powder, containing about 70 per cent of the yellow mineral, was analyzed by Dr. W. F. Hillebrand. The result showed it to be a phosphate of the cerium metals, the approximate amount of the oxides of the latter being 48 per cent; in these approximately 1.20 per cent of thoria was found. This result identifies the mineral with monazite, the only other similar mineral being xenotime, which is mainly a phosphate of yttrium with but little cerium.

Another sample furnished me by Mr. T. Smith of Placerville came from the alluvial gold washing in Wolf Creek near that town. Cleaned from quartz, etc., it appeared as a heavy dark sand consisting of a black iron ore (ilmenite), rounded crystals of red garnet, sharp crystals of zircon, and irregular

grains of a dark yellowish brown mineral with waxy lustre, sometimes showing crystallographic faces. It was found impossible to extract but a small part of the iron ore by the magnet; there was practically no magnetite present. This sand was examined by Dr. Hillebrand qualitatively with the result of finding phosphoric acid, cerium metals and thorium. The yellowish brown mineral is therefore in all probability monazite.

Although the monazite occurs in considerable quantity, it is doubtful whether the mineral can be profitably extracted except possibly as a by-product obtained from the gold washings.

Washington, D. C., May, 1897.

SCIENTIFIC INTELLIGENCE

I. CHEMISTRY AND PHYSICS.

1. *On the Viscosity of Mixtures of Miscible Liquids.*—It has been pointed out by THORPE and RODGER that the properties of a mixture of liquids are rarely identical with those which the mixture should possess on the assumption that the influence exercised by each constituent is proportional to its amount; possibly because the effect of solution in some cases is to break down the complex molecular aggregates of which certain liquids appear to be composed, and in other cases because it leads to the formation of aggregates of the same or of dissimilar molecules. Hence these authors have continued their experiments on the relation of the viscosity of a mixture of two chemically indifferent and miscible liquids to the viscosity of its constituents; with a view to determine whether the viscosity is related to the number of molecules per unit volume or per unit surface. The pairs of liquids used were carbon tetrachloride and benzene, methyl iodide and carbon disulphide, and ether and chloroform. The results obtained afford additional evidence of the fact that the viscosity of a mixture of miscible and chemically indifferent liquids is rarely if ever, under all conditions, a linear function of the composition. A liquid in a mixture rarely preserves the particular viscosity it possesses when unmixed. As a rule the viscosity of the mixture appears to be uniformly lower than the mixture rule would indicate, though no simple rule can yet be traced between the viscosity of a mixture and that of its constituents.—*J. Chem. Soc.*, lxxi, 360, April, 1897.

G. F. B.

2. *On the Specific Heats of the Gaseous Elements.*—The known facts with respect to the specific heats of the gaseous elements have been summarized by BERTHELOT. He points out four distinct cases: (1) where the ratio of the two specific heats is 1.66 and the molecules are generally believed to be monatomic; (2) where the ratio is 1.41 and the molecules behave as if they were diatomic and show no sign of dissociation into monatomic molecules, although at high temperatures there are indications that such dissociation is beginning to take place; (3) where the ratio is 1.30 (chlorine, bromine and iodine) and the diatomic molecules dissociate more or less completely at high temperatures. The ratio in these cases indicates that a considerable amount of internal work is done when the temperature of the gas is raised between ordinary limits; (4) where the ratio is 1.175 and the molecule is tetraatomic, but becomes diatomic at high temperatures. The specific heats at constant volume in the four cases are 3.0, 4.8, 6.6 and 11.4, and the ratios of the three chief numbers are not far removed from 1:2:4. There is therefore some ground for supposing that the specific heats of elementary gases at constant

volume are proportional to the number of atoms in their molecules. — *C. R.*, cxxiv, 119, January, 1897. G. F. B.

3. *On the Synthetic Action of the Dark Electric Discharge.*—An extended series of experiments has been made by LOSANITSCH and JOVITSCHITSCH upon the action of the dark electric discharge in producing chemical synthesis. The apparatus used was the ozonizer of Berthelot, which the authors propose to call an "electriser." Connected with it was a lateral tube dipping in water or mercury, by means of which the change in volume during the reaction could be noted. A current of from 3 to 5 amperes and an electromotive force of 70 volts was used to excite a large induction coil. When carbon monoxide and water vapor was contained in the electriser, the manometer showed contraction at once on passing the spark, the water column rising 400^{mm} in two hours. The tube contained a strongly acid liquid which was proved to be formic acid by its reducing power on ammonio-silver nitrate. Carbon dioxide and water gave formic acid and oxygen when subjected to the dark discharge in the same tube, $\text{CO}_2 + \text{H}_2\text{O} = \text{HCOOH} + \text{O}$; the oxygen subsequently acting on the water to produce H_2O_2 . With hydrogen and carbon monoxide, the pressure diminished to half an atmosphere in three hours, some drops of a thick liquid being formed; there being produced at first formic aldehyde probably, $\text{CO} + \text{H}_2 = \text{COH}_2$, and this polymerizing to glycolaldehyde. Carbon dioxide with hydrogen gave formic acid, and with marsh gas gave at first acetic aldehyde and subsequently its polymer aldol. With hydrogen sulphide, carbon monoxide gave at first formic aldehyde with separation of sulphur; thioformic aldehyde resulting subsequently from the action of this upon the hydrogen sulphide. With hydrogen chloride, carbon monoxide gave probably formyl chloride. With ammonia it yielded formamide with a trace of hydrogen cyanide. Hydrogen sulphide and hydrogen gave carbon monosulphide and hydrogen sulphide; while with carbon monoxide it gave carbon oxysulphide and monosulphide. Nitrogen and water, as already proved by Berthelot, yielded ammonium nitrite. The unsaturated hydrocarbons under these conditions polymerized themselves very readily.—*Ber. Berl. Chem. Ges.*, xxx, 135, January, 1897.

G. F. B.

4. *On Structural Isomerism in Inorganic Compounds.*—By the action of hydroxylamine sulphate upon barium hypophosphite, SABANÉEFF has succeeded in obtaining hydroxylamine hypophosphite, $\text{NH}_3\text{O} \cdot \text{H}_3\text{PO}_2$. Since the salt when in solution oxidizes readily in the air, it is necessary to conduct the operation in an atmosphere of carbon dioxide. The solution thus obtained shows all the reactions of hydroxylamine and of hypophosphorous acid and contains not a trace of phosphorous acid, which however readily appears on the access of air. It is decomposed when evaporated on the water-bath, but on spontaneous evaporation it yields needle-shaped crystals, containing by analysis 30.95 per cent phosphorus. These crystals are hygroscopic, dissolve readily

in water, effloresce at 60° to 70° , fuse at 92° to an opaque mass, sometimes exploding. Cryoscopic examination established the molecular mass corresponding to the above formula. The interest attaching to this compound is due to the fact that it is isomeric (metameric) with hydrogen ammonium phosphite, a salt formed by Amat in 1887 by neutralizing phosphorous acid with ammonia and which has the formula $\text{NH}_3 \cdot \text{H}_3\text{PO}_3$. On evaporating its solution on the water bath, this salt separates in crystals belonging to the monoclinic system. These crystals may be heated to 100° without change and fuse with partial decomposition at 123° . Harden has noted the fact that this is not the first instance of this sort, since Röhrig's sodium-potassium sulphites and Schwicker's thiosulphates are also structurally isomeric.—*Ber. Berl. Chem. Ges.*, xxx, 285, February, 1897.

G. F. B.

5. *The Phase Rule*; by WILDER D. BANCROFT. 8vo, pp. viii, 255. Ithaca, N. Y., 1897. (The Journal of Physical Chemistry.) §3.—Classifying the work done in Physical Chemistry under the heads of Qualitative Equilibrium, Quantitative Equilibrium, Thermochemistry and Mathematical Theory, the author has sought in the present volume to present the subject of qualitative equilibrium from the point of view of the Phase Rule and of the Theorem of Le Chatelier, without the use of mathematics. He defines a phase as a mass chemically and physically homogeneous, i. e., a mass of uniform concentration; and the components of a phase as the substances of independently variable concentration contained in the phase. Now according to the Phase Rule of Willard Gibbs, the state of a phase is completely determined if the pressure and temperature, together with the chemical potentials of its components, be known. Hence the phase may be described by an equation connecting these quantities; while for every other phase in equilibrium with this, there will be another equation containing the same variables. The number of such equations therefore will be the same as the number of phases; while the number of independent variables will equal the number of components plus the temperature and pressure. If n represent the number of components, the number of variables will be $n+2$; and in a system of $n+2$ phases there will be as many theoretical equations as there are variables. In other words, each of the variables has one value and one only for a given set of $n+2$ phases. A given combination of $n+2$ phases can exist at one temperature and one pressure only, the composition of the phases being also definitely determined. Such a system is called a non-variant system, the temperature and pressure at which alone it can exist being known as the inversion temperature and pressure. If the number of phases be $n+1$ however, the system is no longer completely defined, has one degree of freedom and is called a monovariant system. In this system for a given combination of phases there is for each temperature one pressure and one set of concentrations for which the system is in equilibrium; for each pressure, one temperature and one set of concentrations;

and for each set of concentrations, one temperature and one pressure. If however one of the variables be arbitrarily fixed the system is again completely defined. If the number of phases be n , the system is called a divariant system, there being in it two variables which can be arbitrarily fixed before the system is completely defined. In studying the possible variations in equilibrium caused by changing the different variables and the number of phases, the author makes use of the Theorem of Le Chatelier, which says: "Any change in the factors of equilibrium from outside is followed by a reverse change within the system." He then passes to the discussion of nonvariant, monovariant and divariant systems, starting with a single component and increasing to four. Taking, as the most familiar example of a nonvariant system made up of one component, the equilibrium between solid, liquid and vapor, as observed for example in the system composed of ice, water and water vapor, the author points out that according to the Phase Rule a system of this type can be in equilibrium at only one temperature and one pressure, this temperature for water being $+0.0066^\circ$ and the pressure 4.6^{mm} of mercury; these being the inversion temperature and pressure. Applying the theorem of Le Chatelier to the changes in the relative masses of a nonvariant system, we see that if the system is kept at the inversion temperature and the external pressure is continuously increased, a system will result occupying a lesser volume, the vapor condensing until the vapor phase has disappeared and the monovariant system solid and liquid, is left. So changes may be effected by varying the temperature, the pressure being kept constant, the addition or subtraction of heat taking place while the system is kept at constant pressure or at constant volume. The three monovariant resulting systems may exist over a series of temperatures and a series of pressures bounded only by the appearance of new phases. Representing these results in the case of water graphically, the author passes to consider sulphur and phosphorus similarly. In the fourth chapter, he takes up the question of two components, first as anhydrous salt and water, as hydrated salts and as volatile solutes, and then as two liquid phases, as consolute liquids and as solid solutions. Systems of three components are next treated under the heads of two salts and water, pressure curves, solid solutions, isotherms, fractional evaporation, two volatile components, components and constituents and two liquid phases. A single chapter on the general theory of systems of four components completes the book. It appears to us that the task which Dr. Bancroft has set before himself has been admirably done, whether we consider the plan of his work or the manner of its execution. His volume is an admirable presentation of a somewhat abstruse subject which will be most useful to both the chemist and the physicist. G. F. B.

6. *Vorlesungen über Bildung und Spaltung von Doppelsalzen*; von J. H. Van't Hoff, Professor zu der Universität Berlin. Deutsch bearbeitet von Dr. Theodor Paul. 8vo, pp. iv, 95. Mit 54

Figuren im Text. Leipzig, 1897. (Wilhelm Engelman.) 3 marks.—The brochure before us contains the substance of the author's lectures given in Amsterdam in 1894-5 and in Berlin in 1896, upon the formation and decomposition of double salts, being a résumé of the investigations made by the author and his students upon this subject. In putting it into print the lecture form has been changed and the matter has been arranged under three subdivisions. In the first, which is theoretical and general, the action of a sparingly soluble double salt formed by the union of two binary salts, is considered, with reference to the author's theory of dilute solutions and of electrolytic dissociation. In the second, the experimental methods made use of in the investigations are described, these methods being original and most suggestive. In the third, which is special, the behavior of certain salts, such as potassium-cupric chloride, $\text{CuCl}_2 \cdot (\text{KCl})_2 \cdot (\text{H}_2\text{O})_2$, schönite, $\text{MgK}_2(\text{SO}_4)_2 \cdot (\text{H}_2\text{O})_6$, the racemates of ammonium and sodium and of potassium and sodium and the dextro- and lævrotatory Rochelle salts is given at length and shown to be in accord with theory. It is evident therefore that a distinct progress has been made by Professor Van't Hoff over the results given in his "Chemical Dynamics." In the latter book the question of temperature was the one mainly considered, while in the present work all the other conditions upon which the existence of double salts depends are studied minutely. The book is a most valuable addition to the literature of physical chemistry.

G. F. B.

7. *The Limits of Audition*; by LORD RAYLEIGH. (Abstract.)—In order to be audible, sounds must be restricted to a certain range of pitch. Thus a sound from a hydrogen flame vibrating in a large resonator was inaudible, as being too low in pitch. On the other side, a bird-call, giving about 20,000 vibrations per second, was inaudible, although a sensitive flame readily gave evidence of the vibrations and permitted the wave-length to be measured. Near the limit of hearing the ear is very rapidly fatigued; a sound, in the first instance loud enough to be disagreeable, disappearing after a few seconds. A momentary intermission, due, for example, to a rapid passage of the hand past the ear, again allows the sound to be heard.

The magnitude of vibration necessary for audition at a favorable pitch is an important subject for investigation. The earliest estimate is that of Boltzmann. An easy road to a superior limit is to find the amount of energy required to blow a whistle and the distance to which the sound can be heard (e.g. one-half a mile). Experiments upon this plan gave for the amplitude 8×10^{-8} cm., a distance which would need to be multiplied 100 times in order to make it visible in any possible microscope. Better results may be obtained by using a vibrating fork as a source of sound. The energy resident in the fork at any time may be deduced from the amplitude as observed under a microscope. From this the rate at which energy is emitted follows when we know

the rate at which the vibrations of the fork die down (say to one-half). In this way the distance of audibility may be reduced to 30 metres, and the results are less liable to be disturbed by atmospheric irregularities. If s be the proportional condensation in the waves which are just capable of exciting audition, the results may be expressed :

| | | |
|-------|-----------------|--------------------------|
| c' | frequency = 256 | $s = 6.0 \times 10^{-9}$ |
| g' | " = 384 | $s = 4.6 \times 10^{-9}$ |
| c'' | " = 512 | $s = 4.6 \times 10^{-9}$ |

showing that the ear is capable of recognizing vibrations which involve far less changes of pressure than the total pressure outstanding in our highest vacua.

In such experiments the whole energy emitted is very small, and contrasts strangely with the 60 horse-power thrown into the fog-signals of the Trinity House. If we calculate according to the law of inverse squares how far a sound absorbing 60 horse-power should be audible, the answer is 2700 kilometers! The conclusion plainly follows that there is some important source of loss beyond the mere diffusion over a larger surface. Many years ago Sir George Stokes calculated the effect of radiation upon the propagation of sound. His conclusion may be thus stated. The amplitude of sound propagated in plane waves would fall to half its value in six times the interval of time occupied by a mass of air heated above its surroundings in cooling through half the excess of temperature. There appear to be no data by which the latter interval can be fixed with any approach to precision; but if we take it at one minute, the conclusion is that sound would be propagated for six minutes, or travel over about seventy miles, without very serious loss from this cause.

The real reason for the falling off at great distances is doubtless to be found principally in atmospheric refraction due to variation of temperature, and of wind, with height. In a normal state of things the air is cooler overhead, sound is propagated more slowly, and a wave is tilted up so as to pass over the head of an observer at a distance. [Illustrated by a model.] The theory of these effects has been given by Stokes and Reynolds, and their application to the explanation of the vagaries of fog signals by Henry. Progress would be promoted by a better knowledge of what is passing in the atmosphere over our heads.

The lecture concluded with an account of the observations of Preyer upon the delicacy of pitch perception, and of the results of Kohlrausch upon the estimation of pitch when the total number of vibrations is small. In illustration of the latter subject an experiment (after Lodge) was shown, in which the sound was due to the oscillating discharge of a Leyden battery through coils of insulated wire. Observation of the spark proved that the total number of (aerial) vibrations was four or five. The effect upon the pitch of moving one of the coils so as to vary the self-induction was very apparent.—*Royal Institution of Great Britain*, April 9, 1897.

8. *Polarization Capacity*.—C. M. GORDON enters into a historical discussion of this subject, cites the various investigators who have worked upon it and gives his own results, carried out by Nernst's method under the direction of the latter. This method consists in comparing the polarization capacity with a known capacity in the Wheatstone bridge. It was found that for small strength of current the polarization is a reversible process and the contrary electromotive force is accurately given by Kohlrausch's equation $\epsilon = \frac{1}{cfJdt}$, in which c is capacity, f a constant, J equals current strength and t equals time. The capacity of quicksilver electrodes depends mainly upon the quantity of dissolved mercury ions. The capacity of platinum electrodes depends not only upon the occluded hydrogen or oxygen but also upon the concentration of these electrolytes. The results of Gordon do not agree with those of Wien, who found a close dependence of polarization capacity upon the period of the alternating current employed to excite the Wheatstone-bridge combination. Gordon, on the contrary, finds that Kohlrausch's law holds very exactly. The capacity of plates of polished platinum, at a distance of 2^{mm} , and having a surface 0.65^{cm^2} , was about 50 microfarads.—*Wied. Ann.*, No. 5, 1897, pp. 1-29. J. T.

9. *Oscillatory Currents arising in Charging a Condenser*.—SEILER gives a short analytical discussion of the conditions which arise in charging a condenser, and shows that the same equation holds for the charging oscillations as for the discharging oscillations, namely, $T = 2\pi\sqrt{LC}$, in which T represents time, L self-induction and C capacity. The author uses this law for the determination of the self-induction of suitable circuits. He employed a Helmholtz pendulum and used two contacts which broke the charging circuit at definite intervals. It was found that only pure sine oscillations resulted when the circuit contained no small spark gaps.—*Wied. Ann.*, No. 5, 1897, pp. 30-54. J. T.

10. *Cathode Rays*.—In a late discourse delivered at the Royal Institution, Prof. J. J. Thomson described experiments which lead him to believe that the cathode ray phenomena are due to projected electrified particles. Atoms are aggregations of small particles which he terms corpuscles. At the cathode some of the molecules of the gas are split up into these corpuscles, which are then charged negatively and moving with a high velocity are able to pass between the interstices of molecules. The corpuscles are smaller than the atoms of hydrogen. (*Lond. Electr.*, May 21.) Somewhat in line with Thomson's hypothesis is an observation on Dr. Zeeman's discovery of the broadening of spectral lines in a magnetic field, by Dr. Kalischer. (*Elektrotechnische Zeitschrift*, April 15, 1897.) This author points out that there is a recent tendency to return to a "material theory," in which electrical and magnetic phenomena depend not only upon the movement of the ether but also on the material atoms which are sup-

posed to be able to carry electrical charges as in the case of electrolytes. Lorentz explains electrical phenomena by the grouping of corpuscles, and supposes the undulations of light to be the vibration of the ions. It is interesting that he predicted a phenomenon similar to that discovered by Dr. Zeeman. J. T.

11. *Application of the Röntgen Rays to Surgery.*—The recent numbers of French Scientific Journals contain many articles on the application of the X-rays to surgery. M. Ollier describes his researches upon the osseous regeneration in man after surgical operations. Observations hitherto on this subject have been very difficult, and one had to study the cases after death. The X-rays now permit an exact study of the form of the osseous development, and in certain cases render unnecessary the amputation of diseased limbs, since the diseased portions can be now accurately located and removed.—*Comptes Rendus*, No. 20, May 17, 1897.

J. T.

12. *Transparency of Ebonite.*—M. PERRIGOT, in a note presented to the Academy by M. Mascart, states that plates of ebonite 0.5^{mm} thick are transparent to red light; light passing through plates 2^{mm} thick also affects orthochromatic plates.—*Comptes Rendus*, No 20, May 17, 1897.

J. T.

13. *The Theory of Electricity and Magnetism, being Lectures on Mathematical Physics*; by ARTHUR GORDON WEBSTER; pp. 576, 1897. (The Macmillan Company.)—This extensive text book on the mathematical theory of electricity is designed especially for the use of advanced students in our American colleges, and is intended to embody the improvements and additions which have been made in this domain of science since the time of Maxwell's famous work. These additions, derived from the labors of Helmholtz, Hertz, Heaviside and others, are carefully and instructively indicated. An effort to employ a consistent and convenient notation throughout seems to have been pursued with success, for which the author will surely deserve the thanks of his readers.

Professor Webster's experience has taught him that few students who have received only undergraduate instruction in mathematics are sufficiently advanced to enter at once upon the subject of mathematical physics. Hence, to quote from his preface, "I have therefore considered it expedient to prefix a mathematical introduction giving a short treatment of the important subjects of Definite Integrals and of the Theory of Functions of a Complex Variable, indispensable to a study of the Potential Function. For the same reason, I have included a treatment of the fundamental principles of Mechanics *ab initio*, including the deduction of the Principle of Energy, Hamilton's Principle, and Lagrange's Equations of Motion. . . . In this manner it has come about that the book is nearly half finished before the word *Electricity* is mentioned. This may be objectionable to some persons, but I consider it of great importance that the student should be well supplied with tools and practiced in their use before he is called upon to use them on a new and unfamiliar subject. . . . Thus

these introductory chapters may serve as a sort of general introduction to Mathematical Physics."

The author's style is very concise but lucid and interesting. A notable feature of his book is the admirable character of the diagrams both in clearness and sightliness. Professor Webster is to be congratulated upon having produced an excellent book, which is certain to be used and valued.

C. S. H.

14. *Light and Sound*; by E. L. NICHOLS and W. S. FRANKLIN. pp. 201. New York, 1897. (The Macmillan Company.)—The present volume is the third and concluding part of the authors' *Elements of Physics*. The work as a whole, though intended as a college text-book, is rather a digest than a treatise upon this subject, and as such will doubtless find its widest circle of readers among students preparing for examination, or seeking for the theory of the apparatus they must use in the laboratory.

The character of the last part is more freely descriptive than its predecessors, the phenomena and the laws governing them being very properly given more prominence than the formulas which aid in their statement. A commendable feature of the book is the introduction of Huygen's Principle at the beginning, and a development in general of the subjects of reflection and refraction as modifications of a wave-surface at the boundary of different media. There are, however, dreary lapses into "rays" and Optic Geometry in the discussion of mirrors and lenses where the relation between the luminous point and its image is stated, and the reader told that by certain substitutions the given expression may be reduced to an identity. As far as possible the objective wave phenomena of sound and light are treated side by side. Diagrams of a simple character are lavishly distributed throughout the book, and average about one to a page.

Among minor criticisms it may be suggested that fig. 485 would be made much clearer by perversion and rotation through a right angle, and that saturation should be admitted to co-ordinate rank with the other characteristics of a color sensation on p. 101. It is questionable whether anything is gained by such liberties with well-recognized scientific usage as radius of *curvation* for radius of curvature, p. 32; *allotropic* for anisotropic, p. 128, unless perchance this is a misspelling of *æolotropic*; *resonant* dispersion for anomalous dispersion, p. 145; luminescence for simple fluorescence, p. 146.

The chapter on Photometry and the one on Musical Intervals and Scales, which brings the work to a close, though brief, are especially good.

F. E. B.

II. GEOLOGY AND MINERALOGY.

1. *Examination of Deposits obtained from borings in the Nile Delta.*—Prof. JOHN W. JUDD has given to the Royal Society a report on a series of specimens of the deposits of the Nile Delta, obtained by boring operations, a continuation of similar work the results of which were published in 1885. The later borings here described were made at Zagazig, and were carried down 100 feet with a 5-inch pipe, and nearly 100 feet farther with a 4-inch pipe. The work was then discontinued, but renewed again a year later, and by vigorous efforts carried to a depth of $339\frac{1}{2}$ feet with a 3-inch pipe, and from this point a rod was pushed down 5 feet 6 inches farther, so that the exploration attained a total depth from the surface of 345 feet, or 319 feet below the sea level, *without reaching solid rock.*

It is stated that from the surface to a depth of 115 feet the strata passed through in the Zagazig boring closely resembled those already reported upon as occurring in the earlier borings, and consisted of alternations of desert-sand and Nile-mud. The alluvial mud, which prevails from the surface to a depth of 20 feet, contains numerous small tubular and knot-like bodies, doubtless formed by the deposition of calcium carbonate on the rootlets of plants. These bodies become fewer at greater depth and are absent in the clay from depths between 75 and 92 feet. At this level an indurated alluvial mud was found in irregular masses of concretionary argillaceous limestone.

A sudden change in the deposits was found at a depth of 116 feet; here beds composed of a mass of coarse sand and shingle were met with and continued to a depth of 151 feet. At the latter depth a band of yellow clay was passed through, two feet in thickness, and under it sand and shingle beds prevailed till the lowest depth reached, 345 feet. Specially coarse shingle beds were found at the following depths: 121, 160, 175, 190, 208, 250, 265, and 270 feet. In some of these shingle beds the fragments, which were usually well rounded—often, indeed, perfect pebbles—were very coarse, the fragments being of all sizes up to that of a hen's egg.

The general results obtained are similar to those from a boring made at Rosetta in the summer of 1885 and carried to a depth of 153 feet. The sudden change from the blown sand and alluvial mud of the Nile delta to masses of shingle and sand noted at a depth of 115 feet at Zagazig was met with at a depth of 143 feet at Rosetta, showing that the surface of the old gravel deposits is very uneven.

A careful search was made for fossils, especially in the clays, in order, if possible, to fix the geological age of the deposits underlying those of the delta; but this attempt was unsuccessful. The pebbles consisted largely of quartz and chalcedony, and sandstones, all of which, it is suggested by Dr. K. von Zittel of Munich, may have been derived from the Gebel Achmar Sand-

stone. The absence of limestone and pebbles was striking, the softer rocks apparently having been entirely worn away. In the shingle beds pebbles were also found of igneous rocks, which, it is suggested, may have been derived from the side valleys of the Arabian Desert. A number of the pebbles of flint and flinty limestone contained foraminifera and, apparently, sponge-spicules. These fossils are regarded by Prof. Rupert Jones as proving that the fragments containing them were derived from the Eocene (Nummulitic) limestones of Egypt, thus fully confirming the conclusions of Dr. von Zittel.

Of the general sources from which these pebbles were derived Dr. von Zittel writes as follows:—"On the whole it appears to me conceivable that these gravels under the delta originated at a time when the Nile had already formed its present valley, but not to so great a depth as at present. The majority of the rolled rock-fragments would seem not to have been derived from points extremely distant from those in which they are at present found."

Prof. Judd adds: "In considering the nature and sources of the pebbles found in the boring at Zagazig, it may be well to point out that the spot where the boring was carried out is directly opposite to the Great Wady (W. Tumilat), which opens on the delta from the east, and that much of the materials composing the gravels may have been brought down by this tributary rather than by the main stream of the Nile itself. Hence we may not have in this particular section so good an average sample of the contents of the Sub-delta formation as would be obtained at other localities.

"There can scarcely be the smallest doubt that in this Sub-delta formation we have a series of deposits, which were formed under totally different conditions from those which prevail in North Eastern Africa at the present time. The land must have been at an elevation at least from 100 to 300 feet higher than at present, and the Lower Nile, instead of forming an alluvial flat, as at present, must have deposited coarse sands and gravels. It is upon the very uneven surface of this Sub-delta deposit that the alluvial mud and sands of the delta have been deposited, as the surface gradually subsided below the level of the Mediterranean. The interesting problem of the geological age of this Sub-delta deposit remains to be solved, but it may be hoped that the explorations now being carried on by the Geological Survey of Egypt, under Captain H. G. Lyons, R.E., F.G.S., may furnish new and important evidence bearing on this important question. It is to be regretted that the borings carried out by the Royal Society have not set at rest the doubts which have long existed as to the depth at which the solid rock-floor lies below the surface of the delta. But while this has not yet been accomplished, it is satisfactory to have been able to show that the supposed insignificant thickness of the alluvial deposits is altogether a mistake, while the existence of an underlying formation, laid down under conditions totally different to those which prevail at present, has been demonstrated."

2. *Underground Temperatures at Great Depths.*—W. HALLOCK, in a paper published in "The School of Mines Quarterly" (vol. xviii), gives some interesting observations on subterranean temperatures at Wheeling, W. Va., and Pittsburgh, Pa. The original temperatures obtained at different depths of the Wheeling well were given in a paper by Dr. Hallock in this Journal (vol. xviii, 234). These observations were finished in 1891; an oak plug was then driven into the top of the casing and the hole thus protected. In 1893 the hole was opened and it was found full of water to within 40 feet of the top, the water having probably entered at the lower end of the inner casing, 1570 feet below the surface. Careful observations of the temperature were made in 1893, showing results differing not more than $0^{\circ} \cdot 2$ F. from those obtained in 1891, thus indicating that no appreciable circulation even of water goes on in a hole of five inches diameter.

Another well now being bored at Pittsburgh, by the Forest Oil Company, had attained, in February, 1897, a depth of 5,386 feet, and it is expected that the work will be continued until a considerably greater depth has been reached. This well is dry and has an inlet of gas at a depth of 2,285 feet. Observations at a depth of 2,350 feet gave a temperature of 78° , or about the same as that of the Wheeling well. At a depth of 5,000 feet a temperature of $120 \cdot 9^{\circ}$ was obtained, which indicates a temperature of 127° at the bottom. A fuller record of temperatures is to be furnished at a later date.

3. *The Depth of Peat in the Dismal Swamp*; by G. R. WIELAND. (Communicated.)—During a recent visit to the Dismal Swamp region and Lake Drummond I found that a section now to be obtained at the excavation just completed for a lock on the "Feeder Canal" about one-half mile east of Lake Drummond and at the very center of the swamp, gives open testimony to the thickness of the peat accumulation and the origin of the lake.

These are about ten feet of peat containing many large roots, or even tree trunks; this followed by a layer of very clear peat some eight feet in thickness resting on a clear quicksand containing marine shells. Oyster and clam shells are quite numerous, and very likely they could also be obtained by dredging from the sandy bottom of the lake, which has a depth of about twenty feet. The clear peat followed by rooty peat indicates a peat invasion of the swamp area followed by an advance of forest growth. That the accumulation of vegetable matter is only eighteen feet in thickness is in full accord with the quick succession of geological changes the region has undergone, as pointed out by Shaler.—*Ann. Rep. U. S. Geol. Sur., Pt. I., 1888-9.*

4. *Currituck Sound, Virginia and North Carolina—A Region of Environmental Change*; by G. R. WIELAND. (Communicated.)—One of the most important geological changes which has taken place along the Atlantic coast in recent time was the closing up of the Currituck Inlet, North Carolina, by drifting sands in 1828. Previous to that year this inlet formed such a passage from the

ocean through a narrow outer beach into the waters of Currituck Sound as is formed by either the new or Ocracock Inlet to Pamlico Sound now. With the closing of the Currituck Inlet there was the conversion of upwards of one hundred square miles of shallow salt to brackish water area to fresh water; and it is within the memory of men now living that the resultant changes were immediate and striking.

Previously the sound had been a valuable oyster bed. Within a few years the oysters had all died out and their shells may now be seen in long rows where they have been thrown out in dredging for a boatway in the Coinjock Bay, a southwestern extension of the Sound. Further, there were such changes in vegetation as brought countless thousands of ducks of species that had been only occasional before. The salt water fishes were driven out and fresh water fishes took their place.

5. *Papers on Dæmonelix*.—The number of the University Studies, published by the University of Nebraska, for January, 1897, vol. ii, No. 2, contains an important paper by E. H. BARBOUR, on the history of the discovery of *Dæmonelix* with notes on the results of further study in regard to it. This paper is accompanied by seventeen excellent plates showing the forms in great variety, the method of occurrence, and the microscopic structure. The author feels entirely convinced that the forms have organic origin, and are not to be explained as the burrows of a rodent. A second paper by T. H. Marsland, in the same number, gives the result of chemical examination of the composition of the siliceous tubes. The analysis of different samples varies somewhat widely, but the material is shown to consist to a large extent of free hydrous-silicic acid with silicates of iron, aluminum, manganese, calcium, and magnesium.

6. *Papers and Notes on the Genesis and Matrix of the Diamond*; by H. CARVILL LEWIS. 8°, 72 pp., 3 pls. London, 1897. (Longmans, Green & Co.)—This volume consists of two hitherto unpublished papers by the late Prof. CARVILL LEWIS; also a third compiled and edited from manuscript notes left by him by Prof. T. G. BONNEY. The first two papers were read before the British Association.

The work is chiefly petrographic in its nature and in a variety of ways it is proved that the rock accompanying the diamonds in South Africa is of igneous origin, a member of the peridotite group, and that the diamonds have been formed by the contact metamorphism of included fragments of carbonaceous shales. Similar rocks from the United States are also described. The editor differs from the author as to the precise method of occurrence of the igneous rock, while agreeing with him in other particulars. The whole forms an important and valuable addition to our knowledge respecting rocks of this class and the origin of the diamond, and students of this branch of science are much indebted to both Mrs. Lewis and the editor for giving these papers to the public in such attractive form.

L. V. P.

7. *Transactions of the Geological Society of South Africa.* Edited by the Secretary. Johannesburg, 1897. Vol. ii, Nos. 1-11, pp. 1-164, has been issued under the date of March 1, 1897. It contains a series of papers on the geologic formations of South Africa.

8. *The Geological Survey of Canada: Report of the Section on Chemistry and Mineralogy.* By G. CHRISTIAN HOFFMAN, Ottawa, 1897.—This report contains, in addition to the results of numerous technical analyses, assays of ores of different character, etc., also notes on some rare mineral species which have been recently identified in Canada. An analysis is given of the massive *scheelite* from the Malaga gold mining district, Queens Co., Nova Scotia. *Tetradymite* has been found in foliated masses near Liddel Creek, in the West Kootenay district of British Columbia. Its corrected specific gravity was found to be 7.184 and the analysis by R. A. A. Johnston, after deducting some 3½% of quartz, gave the following results:

| Te | S | Se | Bi | Pb | Ag | Tl |
|-------|------|-----|-------|------|------|------------|
| 37.29 | 4.45 | tr. | 53.69 | 3.63 | 0.94 | tr. = 100. |

Altaite has been found with various copper minerals at the Lake View Claim, on Long Lake, Yale district, British Columbia. Its corrected specific gravity was found to be 8.081 and the analysis by R. A. A. Johnston gave the following results:

| Te | Pb | Ag | S |
|-------|-------|------|-------------|
| 43.01 | 54.04 | 2.27 | 0.68 = 100. |

The same locality has also yielded hessite, while the allied species petzite has been found at the Calumet Claim, Kruger Mt., in the Yale district, British Columbia. *Stromeyerite* has been found at the Silver King mine, Toad Mt., in West Kootenay district, British Columbia. It occurs in granular form of specific gravity 6.277, and the mean of two analyses by Johnston gave the following results:

| S | Ag | Cu | Fe |
|-------|-------|-------|---------------|
| 15.74 | 52.27 | 31.60 | 0.17 = 99.78. |

The cobaltiferous variety of arsenopyrites called *danaite* has been obtained from Monte Cristo Mt., Trail Creek, West Kootenay, British Columbia, where it occurs in indistinct crystalline form distributed through the gang of crystalline calcite with a little intermixed quartz. A corrected analysis by Johnston gave the following results:

| As | S | Fe | Co |
|-------|-------|-------|-------------|
| 47.60 | 19.70 | 29.65 | 3.05 = 100. |

III. BOTANY.

1. *Professor van Tieghem's new System of Classification of Phænogamia.*—Those who have watched the recent tendencies in systematic Phænogamic botany will not be wholly surprised to receive a proposition to change the values of some of the characters depending on the structure of the seed, and to base thereon an attempt at the partial reclassification of flowering plants.

In *Comptes Rendus*, May 3, 1897, Professor VAN TIEGHEM of Paris offers for consideration a new system for the classification of Phanerogams, based on the ovule and the seed. For this system, previous papers in the same periodical, beginning with that for March 22 of the current year, and in the *Bulletin of the Botanical Society of France*, for a much longer time, have been preparing the way.

Reserving for a later notice a more detailed account of the principal features of this new system, it is sufficient, at present, to call attention to its revolutionary character. It removes many old landmarks and obliterates many dividing lines, brings about the partial re-arrangement of established genera, placing them in new families, and, in general, initiates a new order of things. One's first impulse is to minimize the significance of the new characters, and to reject the basis proposed. But on careful investigation of the grounds of the new system, especially when such investigation keeps in mind the work by J. G. Agardh, in 1858, on somewhat similar lines, it becomes clear that the new system is likely to challenge wide attention, and that its claims are sure to be heard.

In the first paper of the recent series, the author, after briefly stating modern views relative to the gametes involved in fertilization, calls attention to the sequence of phenomena which, following fertilization, culminate in the production of the "fruit."

Fruits, at their maturity, are of two sorts, one of which has hitherto, in some of its phases, escaped notice. Most frequently the fruit bears (on its outer surface in the case of *Cycads* and *Conifers*, on the inner surface of a closed cavity in the case of all other Phanerogams) one or more distinct bodies which can be easily detached, or which may even become detached spontaneously, when the fruit is ripe. Each of these bodies, formed of an embryo, accompanied or not by albumen, and enveloped by its proper integuments, constitutes what everybody calls a "seed." On its germination, the seed produces a new plant. Most phanerogams have a fruit provided with seeds, *un fruit séminé*. Sometimes, on the contrary, the fruit neither bears nor contains any such free body which can be separated at maturity. In these latter cases, the whole is in one piece which must be planted as a whole in order to obtain by germination the new plant. Such a fruit is devoid of seeds, *un fruit inséminé*. On this difference, the author divides all Phanerogams into two classes, termed respectively *Séminées* and *Inséminées*. The first of these two primary groups is evidently more highly developed than the second. Each of these groups is next divided by the author on the basis of differences in the ovule.

The *Séminées* are first considered. The carpel is often cut along its edge into one or more folioles, more or less distinctly petioled. Each of these folioles produces at some part of the median line of its limb, a conical outgrowth or emergence, which is soon covered by an annular elevation of its own epidermis and, subsequently, is more deeply covered by the infolding of the limb itself. The terminal exodermic cell of this emergence produces directly or indirectly the mother-cell of the endosperm. This highly differentiated body, composed of four distinct parts, is an ovule. The petiole of the foliole is its funiculus; the emergence is the nucellus; its first envelope, comparable to the indusium of ferns, the internal integument; its second envelope is the external integument: each of these envelopes has an orifice, the endostome for the first, and the exostome for the second, together constituting the micropyle. Such an ovule is *nucellé* and *bitegminé*. But often, the nucellus has only one integument, namely the outer (the inner one being wholly wanting). Such an ovule is *nucellé* and *unitegminé*.

These two divisions comprise all *Séminées*. Such plants always have in the pistil one or more ovules with a covered nucellus. Later, during the simultaneous development of the embryo and albumen, each ovule increases in size, and becomes at last a seed as distinct in the ripe fruit as it was in the pistil. In the fruits of these plants, the ovules are permanent, that is to say, throughout their development they preserve their autonomy. "En un mot, elles sont séminées, parce qu'elles étaient pérovulées." According to the character of the integuments, they are divided into the two secondary groups, *Unitegminées*, and *Bitegminées*. The latter are higher in rank than the former.

The primary group of the *Inséminées* presents a larger number of divisions. Certain of their plants have in their pistil one or more ovules, like those of the *Séminées*, that is to say, they have a nucellus enveloped with one or two integuments. In others, the carpel produces one or more ovules, but the nucellus is devoid of any integument, remaining naked, *Integminé*. In others, still, the carpel is cut into one or more folioles, but the foliole is not differentiated into petiole and limb, and it does not produce any conical emergence. The mother-cell of the endosperm is formed under the surface of the exoderm. Such an ovule with neither integument nor nucellus is reduced to a foliole, and is *Innucellé*. Finally, in some others, there is no formation of folioles for the separate production of the mother-cells of the endosperm. These arise from the general exoderm. The pistil is in short, without ovules, *Inovulé*.

These five differences in structure give rise to five secondary groups of *Inséminées*, named respectively *Bitegminées*, *Unitegminées*, *Integminées*, *Innucellées*, and *Inovulées*. Having no ovules in the pistil, the *Inovulées* can, of course, have no seeds in the fruit: but it is just as true that the other four minor groups do not. Those which really possess ovules are characterized by a blending of the peripheral layer of the ovule with the inner

wall of the ovary, through a distinct digestive process, and thus the ovule possesses only a transitory existence as such.

The vast majority of Phanerogams are, of course, *Séminées*. Under the head of Bitegminate in this class come all the Gymnosperms and most of the Gamopetalous Dicotyledons. The Bitegminate comprise all the Monocotyledons, with the exception of *Gramineæ*, and most Dialypetalous and Apetalous Dicotyledons.

The primary group of *Inséminées* is much smaller but much more diversified. The author at this point calls attention to the inexactness of the designation *Spermaphytes*, and shows that there is no absolute necessity for Phanerogams, as such, to have what we have called seeds. The importance of this group of *Inséminées* from a systematic point of view has been emphasized by Professor van Tieghem, in the communications above referred to.

Of these, the *Inovulées*, or *Loranthaceæ* as enlarged, are divided into ten orders, all of which are characterized by the absence of true ovules. It will, perhaps be remembered that his views in regard to certain Loranths, propounded by van Tieghem, in 1869, in his study of *Viscum*, and unfavorably criticised at the time, have been confirmed in good degree by Treub and by Johnson. These ten orders are divided into 21 tribes and 141 genera, more than one hundred of which are new to science.

The *Innucellées*, or *Santalineæ* (including the *Olacales*) are, as re-arranged, placed in two alliances, nine families, nine tribes, and fifty genera, of which five are new.

The *Inséminées* with a naked nucellus constitute the new subdivision, *Anthobolinées*, a single family, with four genera.

The Unitegminate *Inséminées* are the *Icacinées*. The two alliances comprise fifty-two genera, many of which are new.

The Bitegminate *Inséminées* have two sections, three alliances, seven families, and more than three hundred genera. In this group the author places the grasses, and notes the wide separation between *Gramineæ* and *Cyperaceæ*.

Some idea of the results following the adoption of Professor van Tieghem's system can be gained by a slight comparison of it with two accepted methods of classification. In Bentham and Hooker's *Genera Plantarum*, the plants which are here called *Inséminées* are placed in four families, namely *Loranthaceæ*, *Santalaceæ*, *Olacaceæ*, *Balanophoraceæ*, with about 90 genera. In Engler's treatise, now in course of publication, *Myzodendraceæ* is separated from *Santalaceæ*, and *Icacinææ* from *Olacaceæ*, making six families and 120 genera. Van Tieghem makes of these, 36 families and 260 genera. Moreover, he states that this differentiation cannot stop here: increased knowledge of some of the forms will necessitate still further subdivision.

In the last paper of the present series, the author considers the *Séminées*, dividing them first of all into *Astigmates* and *Stigmates*. These correspond very nearly to the Gymnosperms and Angiosperms, or, otherwise, *Archigonieés* and *Anarchegonieés*, or

still further, *Merantheridiées* and *Holantheridiées*. After pointing out the slight inadequacy or, perhaps, inappropriateness of these latter terms, the author proceeds to a consideration of the place which Gymnosperms occupy in the order of development. It is at this point that he states unequivocally his belief that it is incorrect to regard Gymnosperms as standing lower in the scale than the Angiosperms. For his reasons we must refer the reader to the memoir.

On page 924 is given a synoptical table of the highest interest. In this the *Séminées* are exhibited in their new relations, and here the strangest collocations result. One feels, in looking at them, much as he does in reviewing Agardh's pages in which *Lentibulariaceæ*, *Droseraceæ*, *Nepentheæ*, *Cephaloteæ*, etc., are brought near together. The Monocotyledons (with the exception of the excluded *Gramineæ*) stand next to *Nymphœaceæ*, and so on. Without a transfer of the table itself to our pages, it would be useless to dwell on the singular and suggestive juxtapositions and parallelisms. One lays down the treatise with the conviction that the author has done a great service in calling attention once more to the too much neglected field of embryogeny and correlated development.

While examining Professor van Tieghem's interesting treatise, it is impossible to avoid thinking of the difficulties which beset his classification, on palæontological grounds, and also, of the exceptions which occur at different points. Among these exceptions are some which the author candidly calls attention to, such as the genus *Helleborus* in *Ranunculaceæ*, *Lupinus* in *Leguminosæ*, etc. The fact that these genera, which have plants with ovules possessing only one integument, belong at present in Natural Orders characterized by ovules with two integuments, is extremely interesting, and should lead to a reinvestigation of the plants in question with a view to ascertaining whether they may not possess temporarily the missing integument. Many such inquiries will naturally suggest themselves.

As a necessary conclusion of his work, Professor van Tieghem insists that structural characters drawn from the corolla and the relations of the pistil to the verticils of the flower are generally invoked too early in the systematic classification of Phanerogams. He thinks these have their place only after more important matters have been settled; and these questions he finds in the ovule, seed and fruit.

G. L. G.

IV. MISCELLANEOUS SCIENTIFIC INTELLIGENCE.

1. *On the Cause of Secondary Undulations Registered on Tide Gauges.*—In connection with the observations described in the article on the "Seiches" of the Bay of Fundy, by A. W. Duff, in the May number of this Journal, it is interesting to note that a paper was read by NAPIER DENISON, of the Toronto Observatory, before the Canadian Institute, on January 16th, on the secondary undulations found upon self-recording tide gauges.

The writer remarks that his attention was called in June, 1896, to some rapid changes of water level on Lake Huron, at the mouth of the river Kincardine. Here the observed rise and fall appearing to be regular, a set of observations were made with a temporary float. By this means a uniform rise and fall of about three inches were found to occur, averaging nine minutes, that is about eighteen minutes for each undulation; the float moved up stream at the rate of a mile and one-half an hour.

This phenomenon led the author to discuss the analogous observations made at Toronto and St. John, in connection with the changes of barometric pressure; these being plotted on a large scale. The conclusion is reached that the secondary undulations described are due to atmospheric waves or billows started in the upper atmosphere. Some special points in this connection are treated of at length. The author concludes by remarking that, if the above explanations are correct, it might be of great value, in place of eliminating these secondary undulations, when tabulating the primary ones, to increase the amplitude of these secondaries, by lengthening the cylinder, to use one sheet per day to prevent confusion of traces, and make a special study of them, respecting their intensity and time interval, in conjunction with synoptic charts during different types of weather. It appears as if these gauges are extra sensitive barometers, locally forewarning the approach of important storm centers many hours previous, in fact, during a rising or stationary barometer and before the shift of wind.

2. *The Zoological Bulletin*.—It is announced that "The Zoological Bulletin" is to be published as a companion serial to the "Journal of Morphology." It is designed to give prompt publication to shorter contributions in animal morphology and general biology, with no illustrations beyond text-figures. It is to be expected that there will be sufficient material for at least six numbers a year of about fifty pages each.

The editorial work will be directed by C. O. Whitman and W. M. Wheeler, assisted by a number of collaborators, whose names will appear on the title-page. The subscription price per volume of six numbers will be \$3.00, and single numbers will be sold separately at 75 cents each. The first number is now nearly full, and may be expected to appear in June. (Ginn & Company, Publishers.)

OBITUARY.

ALVAN GRAHAM CLARK, the astronomer, died of apoplexy in Cambridge, Mass., June 9, 1897. He was born in Fall River, Mass., July 10, 1832, and was the youngest of two sons. Having received a good school education and prepared himself for the profession of a practical machinist, he entered into partnership, on coming of age, with his father, Alvan Clark, and his brother in the manufacture of optical instruments. The unrivalled skill of all three in the figuring of large objectives, and their great achievements, are too familiar to need comment. The youngest

brother possessed his full share of the family genius, in which ingenuity and persistency were equal factors, and he spent many years abroad in special study of Optics from its mechanical side as well as general astronomy. He was the discoverer of fourteen double stars and was a member of the eclipse expedition to Spain in 1870 and to Wyoming in 1878. He is best known as the discoverer of the Companion to Sirius, which he found Jan. 31, 1862, while testing the 18-inch glass just then finished by the firm for the Dearborn Observatory. For this he received the Lalande prize from the Academy of Sciences of France. A medal of honor was given the firm by the Russian Government for the 30-inch refractive of the Royal Observatory at Pulkova.

The untimely death some years since of his son Alvan, the only male descendant of the family, destroyed the hope which the scientific world shared with the father that the work of the firm might be carried on by the strain which originated it, and Mr. Clark proceeded systematically to preserve the results of his experience, by means of instruction to skilled workmen, especially to Mr. Carl Lundin, his associate for twenty-five years and his natural successor.

It is impossible to separate the work of the three members of the firm. It is best characterized by the remark that almost without exception the construction of lenses of the first class has been for over thirty years wholly in their hands. Their work came to a fitting and not improbably an inevitable conclusion when Mr. Clark delivered to the Yerkes Observatory a few weeks since its 40-inch objective. Mechanical difficulties which good judges thought insuperable beyond 30 inches have been overcome up to 40 inches, and Mr. Clark was already contemplating a still larger lens, but it may well be that the rigidity of glass will fail under the strain of greater weight. The last test of the Yerkes lens before it was shipped from Cambridge indicated a change of definition in different positions in its cell. If this be true, a limit, this time unsurmountable, has been well nigh reached; in view of this it will be eminently proper to say that the firm of Alvan Clark and Sons has written a chapter in Astronomy to which it will be as impossible to add a line as to subtract one.

W. B.

CARL REMIGIUS FRESENIUS, Professor of Chemistry in the Agricultural Institute at Wiesbaden, died in that city on the 11th of June. He was born in Frankfort a. M. on the 28th of December, 1818. In his early life he studied pharmacy and it was while a pharmacist's assistant in Frankfort that his first chemical work was done. In 1845 he removed to Wiesbaden, became the director of the renowned chemical laboratory there, and developed that remarkable ability which finally made him the leading authority in Europe on analytical chemistry. His handbooks of chemical analysis, now known and used all over the world, were published, the qualitative part in 1841 and the quantitative part in 1846. The "*Zeitschrift für analytische Chemie*" was founded by him in 1862 and at once became the center of analytical investigations. For some years he had relinquished his share in the more active management of the laboratory to his son, who will doubtless succeed him.

WARDITE AND VARISCITE.



A large lot of choice specimens of these rare Utah minerals was added to our stock during June. We shall have the Variscite nodules sliced and polished as rapidly as possible, and shall soon be able to offer a surprisingly beautiful collection of polished specimens of this charming mineral, particulars of which will be given next month. In the meantime collectors desiring specimens of Wardite or good pieces of Variscite in the rough, will find a splendid assortment, at reasonable prices, in our stock.

RARE EUROPEAN MINERALS.

An exceptionally large and choice shipment from Europe arrived during June, bringing some \$1,500 worth of most desirable specimens. Among them are Crystallized Whewellite, Sulfoborite, Xanthoconite, Sternbergite, Milarite, Turnerite, Pucherite, Bismutite, Walpurgite, Erythrite, a number of very choice Swiss Smoky Quartz, fine Pyromorphites, rare forms of Wulfenite, excellent, low-priced specimens of Bismuth, beautiful groups of Purple Apatite crystals.

MAGNIFICENT GEORGIA RUTILES.

The wonderful brilliancy, great variety of twinning forms and attractive disposition of the crystals on a matrix chiefly of cyanite, makes our present large and magnificent stock of these specimens a surprise to all who see them. The large loose crystals, some weighing nearly or quite five pounds, are unknown from other localities.

CHOICE CALIFORNIA MINERALS.

Colemanite, a good-sized, carefully-selected lot, at lower prices than they have ever before been offered in New York. Halite, in clear octahedrons of better quality than we have heretofore had. Crystallized Cinnabar, an excellent large lot, cheap. Crystallized Stibnite, specimens of rare merit. Lawsonite, very cheap. Polished slabs of Cinnabar in Quartz, very beautiful

AUSTRALIAN MINERALS.

A choice lot, including fine Embolite, Cerussite, Phacolite, Crystallized Cassiterite, etc.

OTHER RECENT ACCESSIONS.

Magnificent Yellow Wulfenites; beautiful brown and black Descloizite with Vanadinite; choice Phantom Quartz Crystals; richly colored Turquois in good-sized matrix specimens; Cenosite (Kainosite), Epididymite and Edingtonite—three excessively rare Scandinavian minerals; beautiful polished and rough sections of Opalized Wood from Idaho; a few fine Chondrodites from Tilly Foster Mine; a number of excellent Rubellite crystals from Elba.

See our **SPRING BULLETIN** for many other Recent Additions.

124 pp. ILLUSTRATED CATALOGUE, 25c. in paper; 50c. in cloth.
44 pp. ILLUSTRATED PRICE-LISTS, 4c.; Bulletins and Circulars free.

GEO. L. ENGLISH & CO., Mineralogists,
64 East 12th St., New York City.

CONTENTS.

| | Page. |
|--|-------|
| ART. I.—Pressure Coefficient of Mercury Resistance; by A. DEF. PALMER, Jr. | 1 |
| II.—Ctenacanthus Spines from the Keokuk Limestone of Iowa; by C. R. EASTMAN | 10 |
| III.—Studies in the Cyperaceæ, V.; by T. HOLM | 13 |
| IV.—Identity of Chalcostibite (Wolfsbergite) and Guejarite, and on Chalcostibite from Huanchaca, Bolivia; by S. L. PENFIELD and A. FRENZEL | 27 |
| V.—Interesting Case of Contact Metamorphism; by H. W. FAIRBANKS | 36 |
| VI.—Tin Deposits at Temescal, Southern California; by H. W. FAIRBANKS | 39 |
| VII.—Outlying Areas of the Comanche Series in Oklahoma and Kansas; by T. W. VAUGHAN | 43 |
| VIII.—Electrosynthesis; by W. G. MIXTER | 51 |
| IX.—Monazite from Idaho; by W. LINDGREN | 63 |

SCIENTIFIC INTELLIGENCE.

Chemistry and Physics—Viscosity of Mixtures of Miscible Liquids, THORPE and RODGER: Specific Heats of the Gaseous Elements, BERTHELOT, 65.—Synthetic Action of the Dark Electric Discharge, LOSANITSCH and JOVITSCHITSCH: Structural Isomerism in Inorganic Compounds, SABANÉEFF, 66.—Phase Rule, W. D. BANCROFT, 67.—Vorlesungen über Bildung und Spaltung von Doppelsalzen, 68.—Limits of Audition, LORD RAYLEIGH, 69.—Polarization Capacity, C. M. GORDON: Oscillatory Currents arising in Charging a Condenser, SEILER: Cathode Rays, 71.—Application of the Röntgen Rays to Surgery: Transparency of Ebonite, M. PERRIGOT: Theory of Electricity and Magnetism, A. G. WEBSTER, 72.—Light and Sound, E. L. NICHOLS and W. S. FRANKLIN, 73.

Geology and Mineralogy—Examination of Deposits obtained from borings in the Nile Delta, J. W. JUDD, 74.—Underground Temperatures at Great Depths, W. HALLOCK: Depth of Peat in the Dismal Swamp, G. R. WIELAND: Currituck Sound, Virginia and North Carolina, G. R. WIELAND, 76.—Papers on Dæmonelix: Genesis and Matrix of the Diamond, LEWIS and BONNEY, 77.—Transactions of the Geological Society of South Africa: Geological Survey of Canada, G. C. HOFFMANN, 78.

Botany—New System of Classification of Phænogamia, VAN TIEGHEM, 79.

Miscellaneous Scientific Intelligence—Cause of Secondary Undulations Registered on Tide Gauges, 82.—Zoölogical Bulletin, 83.

Obituary—ALVAN GRAHAM CLARK, 83.—CARL REMIGIUS FRESENIUS, 84.

Established by BENJAMIN SILLIMAN in 1818.

THE
AMERICAN
JOURNAL OF SCIENCE.

EDITOR: EDWARD S. DANA.

ASSOCIATE EDITORS

PROFESSORS GEO. L. GOODALE, JOHN TROWBRIDGE,
H. P. BOWDITCH AND W. G. FARLOW, OF CAMBRIDGE,

PROFESSORS O. C. MARSH, A. E. VERRILL AND H. S.
WILLIAMS, OF NEW HAVEN,

PROFESSOR GEORGE F. BARKER, OF PHILADELPHIA,

PROFESSOR H. A. ROWLAND, OF BALTIMORE,

MR. J. S. DILLER, OF WASHINGTON.

FOURTH SERIES.

VOL. IV—[WHOLE NUMBER, CLIV.]

No. 20.—AUGUST, 1897.

WITH PLATE I.

NEW HAVEN, CONNECTICUT.

1897.

TUTTLE, MOREHOUSE & TAYLOR, PRINTERS, 125 TEMPLE STREET.

TASMANIA.

The Island of Flinders, off the north coast of Tasmania, is practically unknown as a mineral locality except to a few Australian collectors. Yet a trip recently made to the Island by a gentleman collecting exclusively for us, yielded

GMELINITE

In magnificent crystals whose size, perfection and beauty excel those of any known examples of this rare species. They occur in cavities in a hard basalt, often having a background of *clear, gem-like Analcites*. Associated with tufts of *Natrolite*, they make rich and handsome specimens. They possess fine lustre and are sometimes $\frac{1}{4}$ inch across.

SPHAEROSTILBITE

Occurs in minute but bright balls, scattered over Natrolite, and also as a thin, transparent coating over primitive form Calcite crystals.

NATROLITE AND ANALCITE

in very pretty association. The clearness and brilliancy of the groups of the latter mineral are unrivalled.

Prices are low, as with zeolites from other localities. 50c. to \$3.00 for fine specimens, though the best of the Gmelinites are \$6.00 to \$9.00.

COLLECTIONS OF MINERALS

For Schools, Teachers, Students and Prospectors.

Send for price list.

 We make a specialty of preparing educational collections, and guarantee accuracy of labelling and strictly scientific arrangement.

BOOKS

On all subjects of Science and Medicine. *Catalogues free.* Please mention subject. The following titles are selected from recent lists:

| | |
|--|--------|
| Boetius de Boot, A. Histoire des Pierreries, 1644..... | \$3.50 |
| Brown, T. Illustrations of the Fossil Conchology of Great Britain and Ireland. London, 1849..... | 5.00 |
| Busk, Geo. A Monograph of the Fossil Polyzoa of the Crag. London, 1859..... | 4.00 |
| Conrad, Blake, et al. Geology of the Pacific R. R. Survey..... | 3.00 |
| Egleston, T. Metallurgy of Silver, Gold, and Mercury in the U. S. 2 vols. New York, 1887..... | 9.00 |
| Greenwell, G. C. Practical Treatise on Mine Engineering. 1855..... | 2.00 |
| Howe, H. M. The Metallurgy of Steel. N. Y., 1891..... | 6.00 |
| Karsten System Der Metallurgie, 5 vols., and Atlas. Berlin, 1831..... | 7.00 |
| Kohn, F. Iron and Steel Manufacture. London, 1869..... | 3.50 |
| Macfarlane, J. The Coal Regions of America, their Topography, Geology, etc. N. Y., 1873..... | 3.00 |
| Phillips, J. Figures and Descriptions of the Palæozoic Fossils of Cornwall, Devon, and West Somerset. London, 1841..... | 3.50 |
| Percy. Metallurgy of Gold and Silver. London, 1880..... | 5.00 |
| Richthofen, F. The Natural System of Volcanic Rocks. San Francisco, 1868..... | 2.50 |
| Rosenbusch. Mikroskopische Physiographie. Stuttgart, 1873..... | 3.50 |

A. E. FOOTE,

WARREN M. FOOTE, Manager.

1317 ARCH STREET,
PHILADELPHIA, PA., U. S. A.

Established 1876.

THE

AMERICAN JOURNAL OF SCIENCE

[FOURTH SERIES.]

ART. X.—*Tamiobatis vetustus*; a new Form of Fossil Skate; by C. R. EASTMAN. With Plate I.

THROUGH the kindness of Mr. F. A. Lucas, of the United States National Museum, the writer has enjoyed the opportunity of studying a remarkable fossil belonging to the collection under the charge of this gentleman. The specimen (Nat. Mus. Cat. No. 1717) was identified by Mr. Lucas as "the skull of a fossil skate," and is shown by the records to have been found in the eastern part of Powell County, Kentucky. Unfortunately, the exact horizon from which it was obtained is not affirmed by the original memoranda accompanying the specimen, but its history seems to leave no doubt that it was derived from rocks occurring *in situ* in that part of Kentucky.

Characters of the matrix.—The fossil is embedded in a weathered block of greenish-gray limestone having a slightly talcose feel, and soft enough to be easily scraped with a knife. The matrix was examined both macroscopically and in thin sections* for traces of other organic remains; but beyond a

* A thin section and fragments of the surrounding rock were submitted recently to Dr. Charles Palache, who was kind enough to furnish the following note upon their mineralogical characters:

"The rock is a very soft greenish-gray limestone, somewhat greasy to the touch. On the under surface it shows a concentric structure, the nodules being small and developed about many centers; but this structure is not sufficiently pronounced to enable one to decide from it either for or against a concretionary origin for the specimen. The rock dissolved readily in cold dilute acid, leaving a residue which amounted to less than one-fourth of the whole, and proved on examination under the microscope to be composed of fragments of feldspar and scales of a kaolin-like mineral. It is doubtless to these scales of kaolin that the rock owes its greasy feel, for the proved absence of magnesia shows that talc is not present, as was at first suspected. Silica is also absent."

AM. JOUR. SCI.—FOURTH SERIES, VOL. IV, No. 20.—AUGUST, 1897.

few minute fragments of Bryozoa and Foraminifera, themselves incapable of precise determination, no accompanying structures were observed. Hence, the only intrinsic evidence as to geological age is that afforded by petrographical characters, and by a study of the fossil itself. But neither class of intrinsic evidence can be altogether relied upon in the present case, owing chiefly to insufficiency of material for comparison; and beyond conceding that the specimen is undoubtedly Palæozoic, we must content ourselves with a statement of opinion that it belongs to such or another horizon. Professor N. S. Shaler, formerly state geologist of Kentucky, is inclined to believe it is from the Waverly group. Mr. Charles Schuchert, who is also familiar with the stratigraphy of the region, ventures the opinion that it was derived from the Corniferous or its equivalent. No other formations besides the Devonian and Carboniferous are represented in the eastern part of Powell County; and this is far beyond the limit of transported material. We may therefore feel a reasonable amount of assurance in assigning our fossil provisionally to the Middle or Upper Devonian.

Description of the remains.—A very fair representation of the specimen is shown in Plate I, and also in the accompanying text-figure, both being of two-thirds the natural size. Obviously it is the cranium of a fossil Elasmobranch, seen from the dorsal aspect; and the characters which at once suggest affinities with the rays are the elongated rostrum, prominent nasal capsules, and antorbital processes for attachment with the pectoral fins. The general form of the skull is fiddle-shaped; there are evenly-rounded cavities for the eyes; the position of the hyomandibular and foramen magnum is indicated; and the median fontanelle as well as openings for the passage of nerves are perfectly distinct. A fontanelle proper does not occur in sharks, the cranial cavity being open in front; and although the tegmen cranii now under discussion differs considerably from existing rays, the above enumeration of features shows that it is decidedly more skate-like than shark-like.

The extreme length of the cranium is 16^{cm}, and its width between the tips of the antorbital spurs is 11^{cm}. It is quite possible that the anterior portion of the rostrum is broken off, although an expansion occurs at the forward part which appears to have been symmetrical and normal. If the rostrum were actually as short, and terminated in the manner shown, a resemblance is to be noted to the conditions existing in *Torpedo*, *Narcine*, and others of the electric rays. But the cutwater is wider, heavier, and less tapering than in recent forms; and the median fontanelle does not appear to have extended forward as

an elongated cavity, nor is it flanked by the compact rods of rostral cartilage, usually so distinct in the skull of both fossil and living skates. In fact, the tegmen cranii would seem to be more completely closed than in either sharks or skates, such as exist at the present day, or are known from the Mesozoic and later rocks. It is scarcely necessary to remark that the substance composing the fossil is calcified cartilage, and the bare spaces are where it has been weathered or worn away. The crust has in places a thickness of about 3^{mm} ; superficially it is

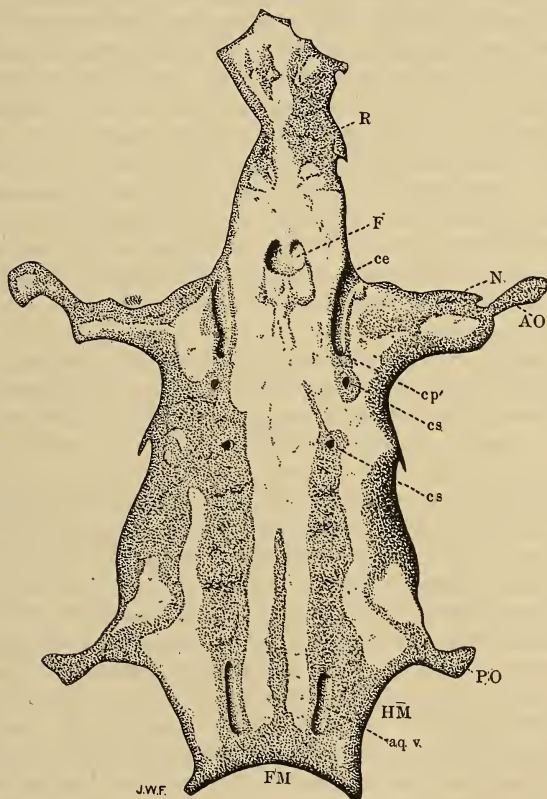

Tamiobatis vetustus gen. et sp. nov. $\times \frac{2}{3}$. AO, Antorbital process; F, Fontanelle; FM, Foramen magnum; HM, Position of hyomandibular; N, Nasal capsules; PO, Postorbital process; R, Rostrum.

quite smooth and compact, but where partially abraded it is seen to be composed of small aggregations which represent the centers of calcification. No dental or integumentary structures are to be observed.

The olfactory capsules (*N*) are slightly abraded along the anterior margin, and it is impossible to detect a suture between them and the antorbital spurs (*AO*). On the other hand, there is a small cleft, which might easily be mistaken for a suture, passing across each of the postorbital processes in a longitudinal direction. But these fissures have every appearance of being fortuitous, and moreover show tool-marks along the edges where they were probed into before reaching the hands of the present writer. Although of unusual size for postorbital processes, we have no choice but to regard them as such; for, if suturedly united with the cranium, they can be homologized with nothing else than the metapterygoid, an element with which they agree neither in shape, size, nor point of attachment. Again, if it were possible to detect sutures here, like indications ought also to exist where the antorbital processes are attached. Granted that they are postorbital processes ("sphenotic" Parker), their size and distal expansion may be accounted for, perhaps, by supposing that membranes were attached to them for the support of the anterior gill arches or other structures. They slant outward and downward so as to occupy the same level, distally, as the tips of the antorbital processes.

The hyomandibular was presumably attached along the sinus marked *HM*. Bounded on either side by prominent occipital condyles was the foramen magnum (*FM*), and here the chondrification was very dense. Just back of the capsules for the eyes on either side is to be seen a small reëntrant angle in the cranial wall. The cartilage is quite thick in this vicinity, and appears to have been eroded by natural causes in the first instance, and further pricked away with the needle so as to produce the effect indicated. It is rather curious that accidents of fossilization and weathering should have affected both sides of the object symmetrically in so many particulars.

The nerve openings are readily identifiable, and have been lettered to correspond with the classic illustrations of Gegenbaur* and Parker.† The superior opening of the ethmoid canal is at *ce*, that of the preorbital canal at *cp'*; *cs* marks the foramina supraorbitalia, present here in two pairs only; and *aq.v.* is the aqueductus vestibuli. All of these openings are very distinct, and their walls densely chondrified.

Probable relationships and systematic position.—If remains of the dentition or dermal ossifications had been preserved in connection with the present specimen, or if skeletons of other

* Untersuchungen zur vergleichenden Anatomie der Wirbelthiere, Heft III. Das Kopfskelet der Selachier, 1872.

† On the Structure and Development of the Skull in Sharks and Skates (Trans. Zool. Soc. London, vol. x, pt. iv), 1873.

Palæozoic Tectospondyli were known, we would not have so slender a basis for comparison; but as it is, we are singularly limited. True, evidence is not wanting to show that cartilaginous fishes with a much-depressed body, probably like that of existing rays, were plentiful in the Palæozoic. The teeth known as Psammodonts, for instance, belonged undoubtedly to ray-like Elasmobranchs; but no trace of their skeletons has yet been discovered. We should not expect them, however, to differ very widely from Mesozoic or even recent rays; their bodies were more generalized, of course, partaking of the nature of both shark and skate; but the idea that the distinction between a shark-skull and a skate-skull was not brought about until the skates began to specialize markedly along particular lines (i. e., since the Jurassic), cannot be entertained. In fact, it does not strike us as surprising that a Palæozoic skull, such as has just been described, should present the resemblance it does to the crania of existing skates. The specimen at hand merely proves what has long since been postulated,—that there were Palæozoic forerunners which were very like Mesozoic rays; and it is to be observed that a number of Mesozoic genera survive at the present day. So far material has been lacking to demonstrate the conservatism as well as remote antiquity of the ray tribe; but as the palæontological record becomes more fully revealed, we shall probably find that this group diverged very early from the parent stem, and did not become highly modified until comparatively late in time.

Of existing families, the Rhinobatids and Myliobatids are generally believed to represent the most nearly ancestral form of ray, and it is natural to look to them first of all for furnishing points of resemblance to the present specimen. But as we have here nothing more than the skull to base comparisons upon, and this is not sufficiently characteristic, it is manifestly impossible to single out any one genus or even family and declare that the fragment approaches it more closely than other living types. We can only affirm that the fossil skull indicates a very generalized condition; it presents some features that are shark-like, and differs notably from the skulls of existing rays. Doubtless the fin-structures and body-parts were also generalized; the indications are that the skeleton of the pectoral fins was not continued forward to the snout; and the dentition was probably weak. In all these respects there is an agreement with *Rhinobatus*, obviously because it, too, possesses a generalized organization; but there are differences in detail which prevent it from being included under the same family. With still less propriety can it be assigned to any other recognized family; but as the group to which it belongs is imper-

fectly definable, there seems to be no other course than to leave it under the head of *incertæ sedis*, or to place it in an appendix to the *Rhinobatidæ*, or possibly the *Myliobatidæ*.

A knowledge of the remainder of the organization of so ancient a fish could not fail to prove of exceptional interest. Where one stratum or concretion is capable of preserving a fragile structure like this, the chances are that more abundant and more perfect material will eventually be forthcoming; and it is not without the hope of stimulating further research that the present contribution is put forward.

As it becomes necessary to designate the above described individual by a special title, notwithstanding its imperfect condition it is suggested that the name *Tamiobatis* be employed for the genus, in allusion to its fancied resemblance to the body of *Tamias*. Specifically it may be known as *Tamiobatis vetustus*.

Museum of Comparative Zoology, Cambridge, Mass.

ART. XI. — *The Florenxia Formation*; by OSCAR H. HERSHEY.

Introduction.—Great progress has been made during the past decade in the study of American Quaternary deposits, and the literature on the subject is already voluminous; but the field is so extensive that many portions of it remain practically untouched. These obscure corners contain much of the evidence which in the future must be relied on to dispose of many of the unsolved problems now before the geologic public. It is by a gradual accumulation of a vast body of facts that we will finally be enabled to read the Quaternary history of America with great accuracy. Hence, every addition to our knowledge of the superficial geology of the continent, however trivial it may appear at the time, possesses some value as increasing our familiarity with the products of the era. On this account I feel it justifiable in placing on record this description and definition of the formation whose designation forms the title of this paper.

Description.—The Florenxia formation is distinctly differentiated into two principal members. The lower is a moderately coarse subangular gravel. It is largely local in origin, in northwestern Illinois, Galena limestone constituting often as

much as 90 per cent of the mass. This was derived by stream erosion from the Pleistocene rock gorges. There is also a certain percentage of drift pebbles which were secured in the erosion of the till and gravel ridges of the district. The rock fragments are sometimes angular, but usually are as well rounded as the Galena limestone will admit by stream action. They are much stained by the hydrated sesquioxide of iron. Some of these stains are a dull earthy black in color, but the greater part are a reddish brown. Locally the iron oxide is present in such amount as to cement the gravel into a soft conglomerate rock. There are rarely any shells or woody matter in this lower or gravel division, as it formed an unfavorable environment for the animal life of the streams, and was deposited at so low a level as not to catch any of the driftwood.

The structure of the Florenxia gravel is not very distinct, but in places it is seen to be irregularly stratified. The surface is everywhere uneven or rapidly undulating. As it is a river deposit, we may presume that this irregularity of the surface is due to its having constituted the stream-bed and not the flood-plain deposit of the Florenxia subepoch. The depressions between the ridge-like elevations of the gravel represent the deeper portions of the streams, while the higher portions of the deposit are the sites of the ancient gravel bars. It is a curious circumstance that the subsequent erosion of this gravel has been so slight that the ancient gravel bars now form rapids in some of the present streams, as in the lower course of Yellow creek. Indeed, the beds of all the larger streams of Stephenson county, Illinois, are nearly everywhere composed of this gravel, overlain in the deeper portions by a little brown silt and mud. That the gravel which forms bars in their beds is not the Modern river gravel except in a few instances, is known from its outcrop in the banks at one or both ends of the bars. The Florenxia gravel is distinguished from the Modern stream gravel by its much greater rounding, a larger percentage of drift pebbles, and its peculiar ferruginous staining. Its stratigraphic relations, also, serve to distinguish it.

The ancient stream gravel now under discussion outcrops in the banks of Crane, Yellow, and tributary creeks and just under the low-water level of the Pecatonica river. It is never exposed to a greater height than two feet, and its total thickness is unknown. Near Bolton a well was reported to have penetrated "blue gravel and driftwood" to a thickness of ten feet. In the Pecatonica river valley it seems to be largely replaced by ferruginous sand, and to extend twenty or more feet below the present river level. It constitutes the main body of the Florenxia formation; but to the geologic student the upper division is of vastly greater interest.

Resting upon the irregular surface of the bed of gravel there is a series of dark blue-green silt, light brownish gray sand, and dark brown carbonaceous clay or muck. The passage from the gravel to the finer sediment is usually quite abrupt, although they are sometimes slightly interstratified. The dark brown muck fills the depressions in the surface of the gravel and varies in thickness from six inches to several feet. It is horizontally stratified, and where the remains of herbaceous vegetation form thin layers, it may be said to be laminated. It contains some small shells, but is not the most fossiliferous member of the formation. What it lacks in the remains of the fauna it partly supplies in the inclusion of many semi-decayed branches and trunks of trees. These are quite numerous in the Crane creek outcrops, and appear to be of two main kinds, one of which is light brown in color and the other black. They are somewhat flattened by pressure, but the branches and trunks represented had an original diameter of one inch or less up to one foot.

The blue-green silt and the light brownish gray sand are in lenticularly-shaped "pockets" interstratified with each other and with the upper portion of the muck. The sand is of well-rounded grains, mostly of transparent quartz, with all the drift rock species represented. It contains a moderately abundant supply of shells, all of small species. But the blue-green silt is the great shell-bearing member of this formation. The species are of a great variety, as the lists later to be presented will indicate, but the shells are all of small size. They are in such abundance that they often make up 10 per cent of the mass. Several hundreds may be separated from a single cubic inch of the silt. This fact constitutes this the most highly fossiliferous formation developed in northwestern Illinois.

Each of the three lithologic types presented by the upper division of the Florenxia formation is characteristically distinct from any other of the district, and they together constitute a series of strata which can be readily identified in every outcrop. The blue-green silt is peculiar to this formation and seems to be coextensive with its distribution, as it has been detected in every outcrop which I have closely examined. The invariable stratification of the entire series, the close association of the most abundant "pockets" of shells with certain lithologic features, and the fact that all the vegetable matter, including the semi-decayed logs or tree trunks, lies in a horizontal position, demonstrate that this division of the formation is not a flood-plain deposit properly so-called, but represents the sediment and driftwood laid down over the gravel in the stream bed, after the land area had begun to subside, thereby establishing a permanently flooded condition of the streams.

Distribution.—Because of the very incomplete condition of the study of the Quaternary geology of northwestern Illinois, the Florenxia formation is known to the writer in the Pecatonica basin only. Here it is found, wherever the proper horizon is exposed, along nearly all the streams of Stephenson county, but has been studied mainly in the valleys of Crane and Yellow creeks and the Pecatonica river. Its outcrops, although fairly numerous, never rise more than a few feet above the stream level, and are usually somewhat obscured by a talus from the bank above. For this reason, the formation has probably failed of investigation in other districts of this portion of the Mississippi basin; but as it represents conditions which were not limited to northwestern Illinois, its existence in all the deeper valleys of this and neighboring states can hardly be doubted. In Stephenson county, the most significant feature of its distribution is the fact that, unlike the drift and loess deposits, it is confined strictly to a certain level. Its upper surface forms a plane which scarcely varies from eighteen inches to two feet above the present low-water level of the streams. It is, therefore, a fluvial formation and can extend from the present streams only so far as the sides of the valleys which were excavated in the drift and rock after the Kansan epoch. In the Yellow creek and the Pecatonica river valleys near Freeport, its width may vary from an eighth to a mile; and in western Winnebago county, its borders are probably two miles apart. It has been estimated that if that portion of the formation which is developed in Stephenson county, were spread as a uniform sheet over the surface of the entire county, it would have a thickness of about six inches.

Stratigraphic relations.—Because of the very interesting nature of the fossil contents, it is of the greatest importance that the age of the Florenxia formation be definitely fixed, and this necessitates a careful investigation of its stratigraphic relations. It rests upon the Kansan drift sheet everywhere except where post-Kansan erosion has completely removed the till and other glacial deposits. It is, therefore, separated from the latter by an erosion interval of the length of which the interglacial rock gorges of this region* are the gauge. The Florenxia formation passes through these rock gorges, completely burying their flat bottoms. Its age is, therefore, not earlier than the practical completion of these gorges. Now the presence of the Iowan *loess* series at various places within them has demonstrated that in age they correspond mainly to the Aftonian epoch. This would seem to indicate that the

* The Pleistocene Rock Gorges of Northwestern Illinois, American Geologist vol. xii, No. 5, November, 1893.

Florenxia formation dates from about the time of the passage from the mild conditions of the Aftonian to the somewhat severer climatic conditions of the Iowan epoch.

The Florenxia formation is overlain with perfect conformity by the basal member of the Iowan *loess* series. The latter varies much in constitution from place to place, but in the Crane and Yellow Creek valleys is a highly ferruginous bright red clay, usually only a few inches in thickness. This ochereous layer derived its large constituent of iron oxide from the red Aftonian soil of the surrounding hills. The upper portion of the Florenxia formation, as already intimated, presents evidence that the subsidence of the region had already advanced so far as to produce a general flooding of the streams. A little later, either through a sudden increase in the movement of land depression, or the obstruction of the mouth of the Pecatonica valley by the advancing Iowan ice-sheet, the flooded Florenxia streams were converted into long narrow lakes which gradually deepened and eroded the red soil on the valley slopes, redepositing it at lower levels as a red and brown sand and the "ferruginous layer" of our Crane and Yellow Creek sections. Almost immediately the extensive fauna and flora of the Florenxia streams and valleys were totally destroyed, so that the Iowan *loess* deposits are practically unfossiliferous.

Several miles northeast of the village of Pecatonica in Winnebago county, there is a section which displays finely the entire series of the Iowan *loess* resting with perfect conformity upon the Florenxia formation. The latter is exposed from the river level to a height of three feet, and is a bed of laminated and variegated clay which, by the erosion of the river, is made to simulate indurated shales. There are a great many black semi-decayed logs projecting from the bank into the river. They reach a thickness of one foot and lie in the position of driftwood. Over this Florenxia clay comes, first, a stratified bed of brown sand, then a less distinctly laminated stratum of fine silt or typical *loess*, followed by the ordinary and easily recognized "main body" of the *loess* series, or Upland *loess*, as I have previously denominated it. Each member of the series is distinct and they have a combined thickness at this locality of 30 feet.

As I shall show presently, the climatic conditions at the time of the deposition of the Florenxia formation in northwestern Illinois, as indicated by the faunal remains, were apparently nearly identical with those usually considered typical of the Aftonian epoch, while its physical relations to the rock gorges and to the overlying *loess* series, together with a presumed presence of the ice, supported by some evidence, on the east

side of the Rock river valley, would seem to connect it with the Iowan epoch. Therefore, we cannot with full confidence refer its age to either epoch, but may perhaps more properly consider it as occupying a transitory stage between the Aftonian and Iowan epochs.*

Fauna.—Collections of shells have been made from two principal localities. The first is in the bank of Yellow creek about 100 feet east of the Chicago, Milwaukee & St. Paul Railroad bridge, and is referred to as the Indian Garden locality, the name having been derived from a popular designation of the peninsularly-shaped body of land enclosed by the creek in the great bend which it makes in the vicinity of the mouth of Crane creek. Great care was taken in securing the shells that they actually came from the Florencia formation and not from Modern silt and muck which might have been deposited on the former by the present stream. An excavation was made into the bank and the fossils secured from under the *loess* which appears higher in the section. No mistake can have been made, as the strata of blue-green silt, light brownish gray sand and dark muck which everywhere in this region form the upper division of the formation, were here present with all their characteristic features, and the shells were taken from undisturbed or originally stratified portions of them. This care was taken because it was early recognized that a fauna of a very similar facies occurs in the Modern alluvial deposits, and the two might easily be confounded.

The second place from which collections were made is the Crane Creek locality. Here the same care was taken as in making the other collection. I do not think there is a possibility of a mistake having been made, as the blue-green silt is typically developed and the *loess* appears in unmistakable form above it.

These collections of Florencia shells were submitted to Dr. W. H. Dall of the U. S. Geological Survey, who has identified them as in the following lists :

*Since this discussion of the stratigraphic relations of the formation was written, I have become aware of the establishment of a new classification of the Illinois and Iowa drift. This applies the term "Aftonian" to an interglacial stage preceding the formation of the Kansan drift-sheet. It, also, establishes a new sheet of drift intermediate in position between the Kansan and Iowan sheets; this is designated the Illinoian drift-sheet. As it is now doubtful which sheet is exposed in Stephenson County, Illinois, and what term should be applied to the long deglaciation interval following, my use of the words "Kansan" and "Aftonian" should be considered as tentative, and relative to the term "Iowan." This will not affect the "age" of the formation, which undoubtedly belongs immediately before that of the Iowan *loess* series. See editorial in American Geologist, vol. xix, No. 4, April, 1897.

| Indian Garden locality. | Crane Creek locality. |
|-------------------------------------|--|
| | Fresh-water species. |
| <i>Pleurocera subulare</i> Lea. | <i>Pleurocera subulare</i> Lea. |
| <i>Planorbis parvus</i> Say. | <i>Campeloma decisa</i> Say. |
| “ <i>bicarinatus</i> Say. | <i>Pisidium</i> spec. ? |
| <i>Valvata tricarinata</i> Say. | “ <i>variabile</i> Prime. |
| <i>Limnæa humilis</i> Say. | “ <i>compressum</i> Prime. |
| <i>Vivipara</i> spec. ? juv. | “ <i>virginicum</i> Gmel. |
| <i>Ancylus tardus</i> Say ? | “ <i>fallax</i> Sterki. |
| “ <i>rivularis</i> Say. | “ <i>punctatum</i> Sterki. |
| “ <i>parallela</i> Hald. | <i>Valvata tricarinata</i> Say. |
| <i>Pisidium</i> spec. ? | <i>Planorbis bicarinatus</i> Say. |
| “ <i>walkeri</i> Sterki. | “ <i>parvus</i> Say. |
| “ <i>cruciatum</i> Sterki. | <i>Limnæa desidiosa</i> Say. |
| “ <i>fallax</i> Sterki. | <i>Sphærium solidulum</i> Say ? |
| “ <i>punctatum</i> Sterki. | “ <i>striatinum</i> Lam. |
| “ <i>compressum</i> Prime. | “ <i>staminium</i> Lam. |
| “ <i>variabile</i> Prime. | “ <i>semile</i> Say. |
| <i>Campeloma decisa</i> Say, juv. | <i>Segmentina armigera</i> Say. |
| “ (embryonic). | <i>Physa heterostropha</i> Say. |
| <i>Sphærium staminium</i> Con. ? | <i>Somatogyrus depressus</i> Tryon. |
| “ <i>striatinum</i> Lam. | <i>Annicola cincinnatiensis</i> Auth. |
| <i>Physa heterostropha</i> Say. | <i>Bythinella tenuipes</i> Couper. |
| <i>Bythinella tenuipes</i> Coup. | |
| <i>Annicola porata</i> Say ? juv. | Terrestrial species. |
| “ <i>cincinnatiensis</i> Auth. | <i>Vallonia costata</i> Mull. |
| <i>Cypris</i> (crustacean). | <i>Zonitoides arboreus</i> Say. |
| Ostracod crustacean. | <i>Hyalinia radiatula</i> Ald. |
| | “ <i>minuscula</i> Binn. |
| Terrestrial species. | “ <i>indentata</i> Say. |
| <i>Hyalinia radiatula</i> Alder. | <i>Pyramidula alternata</i> Say. |
| “ <i>minuscula</i> Binn. | “ <i>striatella</i> Auth. |
| <i>Helicodiscus lineatus</i> Say. | <i>Helicodiscus lineatus</i> Say. |
| <i>Pyramidula striatella</i> Auth. | <i>Succinea avara</i> Say. |
| <i>Pupa contracta</i> Say. | <i>Pupa ventricosa</i> var. <i>elatior</i> Sterki. |
| “ <i>corticaria</i> Say. | <i>Pupa contracta</i> Say. |
| “ <i>holzingeri</i> Sterki. | “ <i>holzingeri</i> Sterki. |
| <i>Succinea avara</i> Say. | “ <i>armifera</i> Say. |
| <i>Carychium exile</i> Ad. ? | <i>Polygyra</i> spec. ? |
| “ <i>exiguum</i> Say. | “ <i>hirsuta</i> Say. |
| <i>Vallonia perspectiva</i> Sterki. | <i>Vertigo indentata</i> Wolf. |
| <i>Strobilops virgo</i> Pils. | |

To the above lists of shells from the Florencia formation I will add *Pisidium abditum* Hald? which was included in a small collection from this horizon made near Bolton several years ago.

An analysis of the species contained in these lists shows that there are undoubtedly present at least fifty distinct varie-

ties, of which thirty are of fresh-water forms and twenty air-breathing or terrestrial species. In comparing them with the lists of shells from the *loess* at Davenport, Muscatine and Iowa City, published by McGee in his memoir on "The Pleistocene History of Northeastern Iowa,"* some interesting differences are noticed. In the Iowa *loess* fauna the gasteropods are mainly pulmoniferous, only a few freshwater species having been discovered. In the Florenxia fauna near Freeport, the larger number of species are of freshwater forms, but the *Unioda*, which appear in the loess, are absent from this formation. The genus *Helix*, which occurs in the *loess* fauna of Iowa and is plentiful in the Modern alluvial deposits of Illinois, has not been identified in the collections made from the Florenxia formation. Furthermore, many of the terrestrial species of the Iowan *loess* are not present in the Florenxia fauna as at present known. There is thus seen to be such a great difference between the fossil contents of the two formations as to point to a great contrast in conditions. The preponderance of freshwater species in the Florenxia fauna indicates the fluvial nature of the formation just as certainly as do its physical features.

The significance of the fossils of the Florenxia formation lies chiefly in the evidence which they furnish of the nature of the climate of that time. Undoubtedly it was neither Arctic nor very cold temperate. I hereby submit the proposition that these fossils demonstrate that the climate was similar to the present. So far as I am aware, there is nothing about the shells which indicates the proximity of a glacier or the existence of conditions favorable to the accumulation of land ice. On the contrary, the prevailing reddish color of the soil on the neighboring uplands as proved by its condition to-day (buried under the *loess*), and the ferruginous layer at the base of the *loess* series, points to a comparative mildness of the climate of that time. This is corroborated by the large amount of driftwood and the vast quantities of small shells enclosed in the Florenxia formation, which indicate that organic life was more abundant in the valleys and streams than it is at present. This abundance of animal and vegetable life is in strong contrast with preceding and succeeding epochs. The Silveria formation contains a few shells of several terrestrial species and a few very small pieces of lignitiferous wood; the Lake Peconica formation is totally unfossiliferous; and the drift nowhere presents any evidence of organic remains. Throughout the Kansan epoch the climate in this region was undoubtedly severe. During the formation of the Iowan *loess*

* 11th Annual Report of U. S. Geol. Survey, pages 460 and 471 of Part I.

series, the conditions were again unfavorable for organisms in northwestern Illinois, as the *loess* of this district is practically unfossiliferous. A few shells have been observed in the *loess* on the bluff at Freeport, and lately a small collection was made from the same formation on the top of the Oakdale esker, about four miles south of Freeport and 100 feet above Crane creek, which is several hundred yards distant. They are exclusively of *Succinea avara* Say. These are the only shells which I have observed in the *loess* of this district except that sometimes over the Florenxia formation the shells of the latter have been disturbed and redeposited in the lower portion of the *loess*.

From a study of the Florenxia and Iowan Loess formations I have concluded that, in northwestern Illinois, the peculiarly mild climatic conditions of the Aftonian epoch continued almost unchanged into the earlier portion of the Iowan epoch; so that the Aftonian flora and fauna remained until long after the beginning of the great movement of depression which characterized the Iowan epoch in this region, and even until the Iowan glaciers had closed around the district on the east and west and were approaching the culmination of their advance. The destruction of the Florenxia fauna was produced less by the presence of the glaciers near by than by the rather rapid conversion of the valleys into lake basins through the general subsidence of the region.

Nomenclature.—The name which I have applied to the formation discussed in this paper is a slight modification of a term once used to designate the basal or fluvial member, as it was then considered, of the Iowan *loess* series of this region. It was referred to as the Florence gravel, the name having been derived from the township of Florence, in Stephenson county. The great diversity of the Quaternary deposits in the Peconica basin has driven me, for the want of a sufficient number of important geographical names, to the necessity of applying township designations to some of the formations discriminated, and this is a case in point. But the term as originally used is of such common occurrence in Europe and America, that I have considered it justifiable in the interests of convenience, definiteness, and euphony to modify the termination of the word. Therefore, I desire that henceforth the deposit be referred to as the *Florenxia formation*.

Freeport, Ill., March 18, 1897.

ART. XII.—*Native Iron in the Coal Measures of Missouri*;
by E. T. ALLEN.

THE occurrence of native iron of terrestrial origin has been until recently a mooted question with mineralogists. In the fifth edition of Dana's *Mineralogy* bearing the date 1868, we read: "The occurrence of masses of native iron apart from meteoric origin is not placed beyond doubt." We now have on record, however, a considerable number of occurrences of terrestrial iron which such authorities as Dana and Tschermak admit to be genuine. Terrestrial iron is claimed to have been found (1)* in eruptive rocks, (2)† in river sands, sometimes associated with gold or platinum, (3) in obvious connection with‡ carbonaceous matter, (4)§ in various other situations.

A careful study of the literature of this subject does not convince one that a number of the specimens described may not have been meteoric, or in some cases, perhaps, artificial. Others, the origin of which is more probable or even established, were obtained only in dust, grains, or very small pieces, so that a study of the physical properties must have been difficult. In many cases we have no published analyses. The number of irons, which are undoubtedly terrestrial and concerning which we have full and satisfactory data, is still so small that new discoveries may possess some interest.

During the past year we have received at this laboratory a number of such specimens of remarkable purity. These were obtained from different localities in Missouri, but proved on inquiry to have a similar origin and paragenesis and almost identical composition and properties.

I. *Natural Iron from Cameron, Clinton Co., Mo.*

This iron, which was received in December, 1895, was obtained in largest quantity and has been most fully examined. It was discovered in drilling out an old well on the land of Mrs. Mary E. Reed of Cameron. Twenty-five years before, the well had been sunk thirty-seven feet till a layer of sand-

* Meunier, C. R., lxxxix, 215, 1879. Smith, *Ann. Ch. Phys.*, V, xvi, 402, 1879. Andrews, *this Journal*, II, xv, 443, 1853. Hawes, *ibid.*, III, xiii, 33, 1877. Cooke, *Ann. Rep. State Geol. N. J.*, 1874, p. 56. Bornemann, *Pogg. Ann.*, lxxxviii, 145, 1853.

† Hussak, *this Journal*, III, vol. xliii, 177, 1892. Page, *ib.*, xxv, 160, 1883. Daubrée and Meunier, C. R., cxiii, 172, 1891. Genth, *Proc. Phil. Soc., Philad.*, xi, 443, 1870.

‡ Shepard, *this Journal*, xl, 366, 1841. Bahr, *ib.*, II, xiv, 275. Bornemann, l. c. § Hayes, *this Journal*, II, xxi, 153, 1856; xxviii, 137, 1857. Genth, *ib.*, xxviii, 246, 1859. Hoffmann, *Proc. R. Soc. Canada, Sec. III*, p. 39, 1890. *Ann. Rep. State Geol. N. J.*, 1883, p. 162. Clemson, *Trans. G. Soc. Penn.*, i, 358, 1834. *Journ. Phys.*, xli, 3.

stone was reached. In 1895 it dried up for the first time. Accordingly the owner decided to deepen it. After drilling through fourteen feet of solid sandstone, the iron was struck at a depth of fifty-one feet. An eight-inch drill and a five hundred pound beater were employed, but so refractory was the vein (or pocket) that the workmen gave up the attempt to penetrate it. On learning from us the nature of the substance, small portions of which were brought to the surface, the work was continued, but it required over half a day to go through it. The workmen judged the thickness of the vein or pocket to be five or six inches. Solid sandstone was found again on the other side of the iron, into which the drilling was continued for twenty-three feet, when the water rose to the same height. We learned on inquiry that no coal or shale was found in the boring although the place is in a coal region and coal has been discovered within five miles.

Examination of sandstone.—The sandstone matrix of this natural iron was of a very light brown color and of moderately fine grain. It possessed a calcareous cement amounting to over thirty per cent of its weight, a little iron in the form of ferric oxide and small quantities of alumina. A microscopic examination of a small portion which had been treated with hydrochloric acid showed that the residue consisted almost entirely of quartz grains. An analysis yielded the following results:

| | |
|---|-------|
| Insoluble in hydrochloric acid | 64.14 |
| [Of this 63.52 per cent = SiO ₂ .] | |
| { CaCO ₃ | 30.90 |
| { MgCO ₃ | .89 |
| { Al ₂ O ₃ | 2.65 |
| { Fe ₂ O ₃ | 1.27 |
| | <hr/> |
| | 99.85 |

The sample of sandstone was considerably crumbled when we received it. From the crumbled portion we extracted a large number of bits of metallic iron with the magnet.

The metal.—The majority of these pieces, both those contained in the crumbled sandstone and those received separately, were flattened and irregular in shape, often hackly around the edges and weighed about half a gram. When they reached the laboratory all were slightly tarnished or coated with a thin film of rust, but when first taken from the ground no rust was visible, we were informed, though none of the pieces were bright except where fresh fractures had been made by the drill. The resistance which the iron offered to the drill showed that there was a solid mass imbedded in the stone, and this mass was evidently beaten to pieces. The iron was so malleable that it could be beaten out cold on an anvil to very thin plates, though not without cracking somewhat on the edges. Its hardness was just about that of fluorspar, the minerals

scratching one another with difficulty. When filed the metal exhibited a color almost silver white and a high luster which remained permanent in a dessicator. While most of the pieces weighed about .5 gr., there were a number which weighed 2 grms. or more, one weighed 8.4 grms. and the largest 45.4 grms. The last was only a little darkened by tarnish when we received it. On the edge a layered structure was very noticeable. In the other pieces this was not so apparent, but they often separated along cleavage planes when hammered and by the aid of a pair of pliers, one layer after another, sometimes exceedingly thin, could be peeled off more or less perfectly. The surface between these layers was sometimes blackened, but often entirely fresh and metallic. Probably on account of this structure and perhaps also on account of unequal hammering by the drill, the specific gravity of different pieces varied considerably. That of the largest was only 7.43, while that of the smaller pieces varied (after the outer layer was removed) from 7.63 to 7.73. The layered structure also made it difficult to produce a continuous polished surface, the boundaries of the layers showing in it as fine irregular lines at whatever angle the plane was cut. The action of dilute nitric acid was tried on such a surface, but it appeared to attack it evenly, developing no semblance to Widmanstätten figures. In the chemical examination of the iron we employed only the metallic core prepared by filing away the outer layers. This dissolved in hydrochloric acid with the evolution of hydrogen which possessed comparatively little odor, and left a very slight residue of crystalline silica and a few minute fragments of carbonaceous matter. A careful analysis of a solution prepared from several grams of the iron, failed to reveal any traces of copper, nickel, cobalt or other foreign metals. With the exception of oxide of iron, silica, phosphorus and carbon in small quantities were the only impurities detected. The analyses made of different pieces gave nearly identical results.

IRON—

1. Metal taken = .2910 gr. KMnO_4 required = 42.53^{cc}. 1^{cc} = .006785 gr. iron. Fe = 99.16 per cent.

An examination of the iron taken, by means of a lens, showed small dots of rust in a few places that seemed to penetrate deeply. Other determinations made on smaller pieces where the rust appeared to have affected the iron still more gave lower results.

2. Metal taken = .2147. KMnO_4 required = 31.31^{cc}. Fe = 98.93.
3. Metal taken = .4611. KMnO_4 required = 66.88^{cc}. Fe = 98.40.

SILICA—

1. Metal taken = 3.1603 gr. SiO_2 obtained = .0117 gr. = .37 per cent.
2. Metal taken = 5.2953 gr. SiO_2 obtained = .0196 gr. = .37 per cent.

The silica obtained was all in the form of minute crystalline grains, and since the iron was found imbedded in sandstone it appeared not unlikely that the grains were originally present as such in the metal. A microscopic examination of the interior of several pieces threw no light on this point.

CARBON—

This was determined by dissolving the iron in potassium cupric chloride and collecting the carbon dioxide formed by burning the residue.

| | |
|--------------------------------|--------------|
| 1. Metal taken | 1.4036 gr. |
| CO ₂ obtained | .0038 gr. |
| C | .07 per cent |
| 2. Metal taken | 2.4820 |
| CO ₂ obtained | .0055 |
| C | .06 per cent |

PHOSPHORUS.

| | |
|---|---------------|
| Metal taken | 3.1603 |
| Mg ₂ P ₂ O ₇ | .0237 gr. |
| P | .207 per cent |

Complete Analysis.

| | |
|------------------------|--------|
| Fe | 99.16 |
| SiO ₂ | .37 |
| C | .065 |
| P | .207 |
| | <hr/> |
| | 99.802 |

II. *Natural Iron from Weaubleau, Hickory Co., Mo.*

This iron was received from the firm of Butler & Whitaker of Weaubleau, who discovered it while digging for coal about five miles from that place. They drilled through twenty-seven feet of interstratified sandstone and clay, when they reached a thin seam (two or three inches in thickness) of poor lignite. Eight feet deeper, at a total depth of thirty-five feet, they struck a stratum of gray clay in which were a few pieces of metallic iron. Considerable coal seemed to exist in the vicinity, as they found it eighteen inches thick at the same depth, not far from this spot.

The clay contained 79.32 per cent silica and 1.67 per cent iron. When the iron was first taken from the earth, it was dark with tarnish though not apparently rusted. Only a few pieces were obtained. We received but two, which after filing away the outer portions weighed respectively 3 grms. and 3.9 grms. Both physically and chemically the iron strongly resembled the Cameron specimens. The layered structure was not however so marked and the percentage of metallic iron was

a little higher, probably on this account. The specific gravity of the larger piece was 7.58. Of two small fragments of the other, weighing about half a gram each, we found the specific gravities 7.83 and 7.88.

Analysis.

IRON—

1. Metal taken = .3919 gr. 59.57^{cc} KMnO₄ required. 1^{cc} = .006530 gr. Fe. Fe = 99.27 per cent.
2. Metal taken = .3830 gr. 58.37^{cc} KMnO₄ required. Fe = 99.52 per cent.
3. Metal taken = .1596 gr. Dissolved in hydrochloric acid, precip. by NH₄OH and determined as Fe₂O₃.

| | |
|--|------------|
| Fe ₂ O ₃ + FePO ₄ | .22697 gr. |
| Cal. for FePO ₄ | .00047 |
| | .22650 |

Fe₂O₃..... .22650 Fe = 99.34 per cent

SILICA—

Metal taken = 3.2052 gr. SiO₂ = .0100 gr. SiO₂ = .31 per cent.

PHOSPHORUS—

Metal taken = 3.2052 gr. Mg₂P₂O₇ = .0148 gr. P = .128 per cent.

Analysis.

| | |
|------------------------|---------------|
| Fe | 99.39 |
| SiO ₂ | .31 |
| P | .13 |
| C | undetermined. |

III. *Natural Iron from Holden, Johnson Co., Mo.*

This iron was discovered by Mr. G. W. Hills of Holden while drilling a well. The upper strata passed through consisted chiefly of fire-clay. At a depth of 21 ft. coal was struck. This continued for 18 in., and then followed fire-clay again until at a depth of 37 ft. the drill struck something hard which caused it to rebound. After some time, no headway being made, the drillings were examined. A few small pieces of metal about the size of lima beans were drawn up with the clay. The discoverer informed us that he drilled out altogether about as much of the substance as one could hold in the hand. As he was disappointed in his original object the well was eventually filled up.

We received specimens of the drillings and one piece of the metal which weighed about 3 grms. The clay in which the iron occurred was compact and gray in color. It contained 65.25 per cent of silica and 3.63 per cent of iron. When first brought to the surface, the iron resembled tarnished silver, but showed no signs of rust. Its hardness was about the same as that of the two specimens previously described, sp. gr. = 7.49.

After solution in aqua regia a considerable residue of silica, which was partly gelatinous, and some carbonaceous matter remained.

SILICA—

2.9929 gr. iron taken. Silica = .0495 gr. = 1.65 per cent.

IRON—

The filtrate from silica was diluted to 500^{cc} and aliquot parts were titrated with permanganate solution.

a. 25^{cc} sol. required 23.08^{cc} KMnO_4 .

b. 20 “ “ 18.47 “

1^{cc} KMnO = .006292 gr. Fe.

Iron = (a) 97.09 (b) 97.10

The specimen analyzed was not examined until several months after it was taken from the ground and, although all the outer portions were carefully filed away before the analysis, it was probable that the rust had penetrated deeply and that small portions were unremoved. The original percentage of metal was probably higher.

PHOSPHORUS—

405^{cc} of the filtrate mentioned above was examined for phosphorus.

$\text{Mg}_2\text{P}_2\text{O}_7$ obtained = .0155 gr. P = .176 per cent.

Analysis.

| | |
|------------------|---------------|
| Iron | 97.10 |
| Silica | 1.65 |
| Phosphorus | .176 |
| Carbon | undetermined. |

Conclusion.—All the specimens here described were found at such a depth from the surface and under such conditions that there can be no doubt of their terrestrial origin. That they were portions of the drill, is of course untenable, not only because the drills remained intact but because of the remarkable softness of the specimens, their peculiar structure (in the case of the Cameron specimens) and the remarkable resistance which two of them offered to the drill. The close connection of two of them with coal and the location of the third in the same geological formation (the Coal Measures) and in the comparatively near vicinity of coal, is significant of their origin, though the minute quantity of carbon in the metal is notable. Whatever the process of reduction, the location of the irons in all three cases was very favorable to preservation.

As regards composition, not only is the purity of these specimens remarkable, but it is interesting to note the absence of nickel, an element always found in meteoric irons, but rarely in those of terrestrial origin.

School of Mines of the University of Missouri,
Rolla, Missouri.

ART. XIII.—*On Bixbyite, a new Mineral, and Notes on the Associated Topaz*; by S. L. PENFIELD and H. W. FOOTE.

Bixbyite.—The mineral to be described in the present article was sent to us for identification by Mr. Maynard Bixby of Salt Lake City, Utah. Concerning its occurrence we are informed that the mineral is found very sparingly in one or two small areas on the edge of the desert about thirty-five miles southwest of Simpson, Utah. The crystals are implanted upon topaz and decomposed garnet and rhyolite and have evidently been formed by fumarole action.

The mineral crystallizes in the isometric system, usually in cubes, some of which measure over 5^{mm} on an edge. These are occasionally modified by the trapezohedron, 211, and on one small specimen the cubes and trapezohedrons are developed with almost ideal symmetry as shown in fig. 1. When measured on the goniometer the crystals gave fairly good reflections of the signal and $211 \wedge 112$ was found to be $33^{\circ} 40'$; calculated $33^{\circ} 33\frac{1}{2}'$. The mineral breaks with an irregular fracture, and on one or two specimens traces of octahedral cleavage were observed. The color is brilliant-black with metallic luster, and the streak is black. The hardness is 6 to 6.5. The specific gravity of the material used for the quantitative analysis was taken on a chemical balance and found to be 4.945. The mineral fuses before the blowpipe at about 4 and becomes magnetic. When very finely powdered, it dissolves with some difficulty in hydrochloric acid with evolution of chlorine.

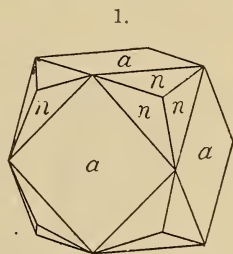

Method of Analysis.—The material for analysis was separated in a nearly pure condition by the thallium-silver nitrate mixture. The mineral was treated with strong hydrochloric acid in a flask connected with a condenser, and the chlorine liberated was distilled over into a solution of potassium iodide. Free iodine was then determined volumetrically with standard thiosulphate and iodine solutions, from which the amount of available oxygen was calculated. After filtering off a small amount of insoluble material, iron, aluminium and titanium were separated from manganese and magnesium by the basic acetate method. The three oxides were weighed together, iron was then determined by titration with permanganate solution and titanium was twice precipitated by boiling the nearly neutral dilute sulphate solution for two hours in the presence of

sulphur dioxide. It was weighed as TiO_2 . From the filtrate from the basic acetate precipitation, manganese was precipitated with excess of bromine water. The precipitate, after filtering, was dissolved in a solution of sulphur dioxide, precipitated as phosphate and weighed. Magnesium was precipitated from the first manganese filtrate as phosphate.

Following are the results of the analyses :

| | I. | II. | Average. | Ratio. |
|-----------------|-------|--------|----------|--------|
| SiO_2 | 1·24 | 1·19 | 1·21 | |
| Al_2O_3 | 2·57 | 2·48 | 2·53 | |
| Fe_2O_3 | 47·81 | 48·15 | 47·98 | ·300 |
| TiO_2 | 1·62 | 1·78 | 1·70 | ·022 |
| MnO | 42·08 | 42·02 | 42·05 | ·592 |
| MgO | 0·12 | 0·09 | 0·10 | ·002 |
| Avail. O | 4·37 | 4·39 | 4·38 | ·274 |
| | 99·81 | 100·10 | 99·95 | |

The silica and alumina are regarded as impurities, as only a trace of them went into solution when the mineral was treated with hydrochloric acid. In preparing the mineral for analysis, a variation in specific gravity was observed, owing to the fact that some of the dark particles were buoyed up by impurities, but in order to obtain sufficient material for analysis, it was necessary to include some of the lighter portion. It is probable from the results of the analysis that some topaz was present, for the ratio of silica to alumina is about 1:1 and topaz is intimately associated with the bixbyite.

Leaving silica and alumina out of account, two formulas are possible. Considering the titanium as Ti_2O_3 , the oxygen derived from the TiO_2 , 0·16 per cent, plus the available oxygen, 4·38, total 4·54 per cent, is about sufficient to convert the MnO into Mn_2O_3 , the amount required for 42·05 per cent, MnO being 4·74. The composition therefore can be expressed as R_2O_3 , where $R = Fe, Mn$ and a little Ti . The proportion of Fe to Mn is 1:0·99 or almost 1:1, so that disregarding Ti_2O_3 , the composition is $FeMnO_3$. If the mineral is an isomorphous mixture of Fe_2O_3 , Mn_2O_3 and Ti_2O_3 , we should expect it to be rhombohedral and to belong to the hematite, corundum and menaccanite group, and also it is not probable that the Fe and Mn would be present in the proportion 1:1.

As the mineral is isometric, it seems more reasonable to regard it as a compound having essentially the composition $FeO \cdot MnO_2$ and related to the isometric mineral perovskite, $CaO \cdot TiO_2$. On this basis, the results of the analysis may be put in the following shape :

| | | Ratio. | |
|--|-------|--------|----------|
| FeO | 43·17 | ·600 | } = ·602 |
| MgO | 0·10 | ·002 | |
| MnO | 42·05 | ·592 | } = ·613 |
| TiO ₂ | 1·71 | ·021 | |
| Avail. O and O from Fe ₂ O ₃ | 9·18 | ·574 | |
| SiO ₂ | 1·21 | | |
| Al ₂ O ₃ | 2·53 | | |
| | 99·95 | | |

The ratio of Fe+Mg:Ti+Mn is ·602:·613 or nearly 1:1, while the oxygen is almost sufficient to convert the MnO into MnO₂, as indicated by the ratio MnO:O = ·592:·574. As oxygen was determined perhaps as accurately as any other constituent, it seems possible that a small amount of manganese may be present as protoxide, replacing FeO. If enough manganese be taken as protoxide to make the ratio of RO to RO₂ exactly 1:1, the results become:

| | | Ratio. | |
|--------------------------------------|-------|--------|--------|
| FeO | 43·17 | ·600 | } ·608 |
| MgO | 0·10 | ·002 | |
| MnO | 0·40 | ·006 | |
| TiO ₂ | 1·71 | ·021 | } ·608 |
| MnO | 41·65 | ·587 | |
| O | 9·18 | | |
| SiO ₂ | 1·21 | | |
| Al ₂ O ₃ | 2·53 | | |
| | 99·95 | | |

The oxygen necessary to convert 41·65 per cent of MnO to MnO₂ is 9·38, which is only slightly in excess of that actually found in the analysis. It seems therefore probable that the mineral is essentially FeMnO₃=FeO.MnO₂, in which small quantities of MgO and MnO are isomorphous with FeO and a little TiO₂ with MnO₂. The mineral is therefore to be regarded as a ferrous salt of manganous acid H₂MnO₃, corresponding to braunite MnMnO₃, which is supposed to be the manganese salt of the same acid.

We take pleasure in naming this mineral after Mr. Bixby, who has generously supplied us with material for investigation, and has gone to a great deal of trouble and pains to secure the specimens.

Topaz.—On the topaz with which bixbyite is associated the following forms were observed:

a , 100 m , 110 d , 201 y , 041 u , 111
 c , 001 l , 120 f , 021 o , 221

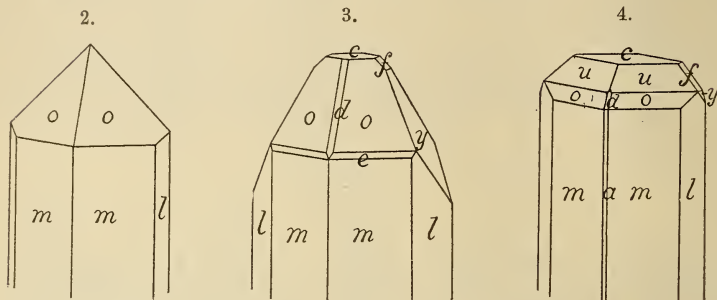

The prevailing types of the crystals are shown in figs. 2, 3, and 4. Some of the crystals are more than 4^{cm} long and are transparent and colorless; a few have a delicate wine color, and many are either opaque white or partially so. The opaque crystals, as shown by microscopic examination, are not pseudomorphs but consist of fresh unaltered topaz containing minute quartz crystals, which evidently have been included during crystallization.

Associated with the topaz crystals are rough trapezohedrons which apparently were once garnet, but which have suffered alteration. The garnet is wholly gone and the crystals consist of bixbyite with either quartz, topaz or both. The garnet was probably the manganese variety, spessartite, which has been observed by Cross* at Nathrop, Colo., associated with topaz in rhyolite, an occurrence similar to that in Utah.

ART. XIV.—*Note concerning the Composition of Ilmenite*;
 by S. L. PENFIELD and H. W. FOOTE.

THE existence of a molecule $R^{II}O \cdot R^{IV}O_2$ in bixbyite and perovskite brings to mind the views concerning the composition of ilmenite. One of these is, that the mineral is $RO \cdot TiO_2$ ($R=Fe$ and Mg), as advanced by Mosander† and adopted by Rammelsberg‡ and Hamberg.§ The other, that it is R_2O_3 , or an isomorphous mixture of Fe_2O_3 and Ti_2O_3 , as advanced by Rose|| and adopted by Groth.¶

* This Journal, xxxi, p. 432, 1886.

† Pogg. Ann., xix, p. 219.

‡ Pogg. Ann., civ, p. 497.

§ Geol. Fören., i, Stockholm Förhandl., xii, p. 604.

|| Pogg. Ann., lxii, p. 119.

¶ Tabellarische Übersicht der Mineralien, 3 Aufl., Braunsch., 1889, p. 40.

There are both crystallographic and chemical grounds for accepting Mosander's formula. Hematite and artificial Ti_2O_3 both crystallize in the rhombohedral division of the hexagonal system, and the lengths of their vertical axes are respectively 1.359 and 1.316. Ilmenite, however, differs in its symmetry from the foregoing, for it crystallizes in the rhombohedral-tetartohedral division of the hexagonal system, and the length of its vertical axis, 1.385, is not between those of hematite and titanium sesquioxide, which would be expected if ilmenite were an isomorphous mixture of Fe_2O_3 and Ti_2O_3 . Moreover, if the two sesquioxides are isomorphous it would be expected that at times the Ti_2O_3 would be in excess of the Fe_2O_3 , which has never been observed, although in some cases the ratio of Fe : Ti is practically 1 : 1.

The presence of the protoxide magnesia in almost all of the ilmenites that have been examined cannot be accounted for if the mineral is assumed to be an isomorphous mixture of the sesquioxides Fe_2O_3 and Ti_2O_3 . The quantity of magnesia is usually small, less than five per cent, but Cohen* has described an ilmenite from Du Toit's Pan, South Africa, occurring in rounded grains which contain 12.10 per cent MgO , and Rammelsberg† a crystallized one from Layton's Farm, Warwick, N. Y., containing 13.71 per cent MgO . Groth,‡ in commenting upon Rammelsberg's analysis, points out that the material might have been impure. Having on hand in the Brush collection some excellent crystallized specimens from this locality, we thought it best to make a new analysis. The material was derived from a single crystal. This was rough so that accurate measurements could not be made, but the habit was that of ilmenite, and by means of the contact goniometer the forms *c*, 0001, *r*, 10 $\bar{1}$ 1 and *s*, 02 $\bar{2}$ 1 were identified. The analysis (by Foote) is given below, together with that made by Rammelsberg:

| | I. | II. | Average. | Ratio. | | Rammelsberg. | Ratio. |
|------------------|--------|--------|----------|--------|--------|--------------|--------|
| SiO_2 . . . | 0.44 | 0.31 | 0.37 | .006 | } .722 | ---- | |
| TiO_2 . . | 57.30 | 57.28 | 57.29 | .716 | | 57.71 | .721 |
| FeO . . | 24.08 | 24.23 | 24.15 | .335 | } .749 | 26.82 | .372 |
| MgO . . | 16.01 | 15.93 | 15.97 | .399 | | 13.71 | .342 |
| MnO . . | 1.09 | 1.12 | 1.10 | .015 | | 0.90 | .013 |
| Fe_2O_3 . | 1.99 | 1.75 | 1.87 | .012 | ---- | | |
| | 100.91 | 100.62 | 100.75 | | 99.14 | | |
| Specific gravity | ----- | ----- | 4.345 | | 4.303 | | |

* Jahrb. Min., 1877, p. 695.

† Loc. cit.

‡ Loc. cit.

In the two analyses, the ratio of $\text{RO}_2 : \text{RO}$ is very close to 1 : 1, thus indicating the existence of the molecule $\text{RO} \cdot \text{TiO}_2$, where $\text{R} = \text{Fe}$ and Mg .

It is thus *definitely proved* that in this crystallized variety of ilmenite there is a molecule $\text{MgO} \cdot \text{TiO}_2$ or MgTiO_3 , and it seems most reasonable to suppose that the iron also is present as $\text{FeO} \cdot \text{TiO}_2$, isomorphous with $\text{MgO} \cdot \text{TiO}_2$, and not as an isomorphous mixture of Fe_2O_3 and Ti_2O_3 . It cannot, however, be told by chemical means that all of the titanium exists as a tetravalent element, for on dissolving the mineral for analysis, Ti_2O_3 if present would oxidize to TiO_2 at the expense of Fe_2O_3 , and the analysis would show an equivalent of $\text{FeO} \cdot (\text{Fe}_2\text{O}_3 + \text{Ti}_2\text{O}_3 = 2\text{TiO}_2 + 2\text{FeO})$.

In the published analyses of ilmenite, where the ratio of $\text{TiO}_2 : \text{RO}$ is very constantly 1 : 1, there is almost without exception an excess of Fe_2O_3 , amounting in some cases to a large per cent, as may be seen by examining the list of analyses in Dana's System of Mineralogy, p. 218, and, as Hamberg has pointed out, it is reasonable to suppose that the hematite molecule Fe_2O_3 or FeFeO_3 is capable of mixing with the ilmenite molecules FeTiO_3 and MgTiO_3 , just as CaCO_3 and NaNO_3 are practically isomorphous.

Laboratory of Mineralogy and Petrography,
Sheffield Scientific School, New Haven, Conn., April, 1897.

ART. XV.—*The Separation of Aluminum and Beryllium by the action of Hydrochloric Acid*; by FRANKE S. HAVENS.

[Contributions from the Kent Chemical Laboratory of Yale University— LXIV.]

IN a former paper* a method was described for the determination of aluminum in the presence of iron, based upon the fact that the hydrous aluminum chloride $\text{AlCl}_3 \cdot 6\text{H}_2\text{O}$ is practically insoluble in a mixture of strong hydrochloric acid and anhydrous ether saturated with hydrochloric acid gas, while the ferric chloride is entirely soluble in that medium.

The work to be described in this paper is an extension of this process to cover the separation of aluminum from beryllium, with the subsequent determination of the beryllium by weighing as the oxide after conversion to the nitrate and ignition.

The aluminum chloride solution was prepared by dissolving the so-called pure aluminum chloride of commerce in as little water as possible, precipitating and washing free from iron with strong hydrochloric acid, dissolving the chloride thus obtained in water, precipitating the hydroxide by ammonia, washing the precipitate free from all alkalies, and redissolving it in hot hydrochloric acid. From this solution, after cooling, gaseous hydrochloric acid precipitated the pure hydrous chloride. This prepared chloride was dissolved in water and the solution standardized by precipitating with ammonia the hydroxide from weighed portions and weighing as the oxide. The solution of beryllium used was made by dissolving in water beryllium chloride found to be free from iron by the sulfocyanate test, and giving no precipitate when tested by the gaseous hydrochloric acid process to be described later on. This was standardized by precipitating with ammonia the hydroxide from weighed portions and weighing the ignited oxide in the usual manner.

In the experiments of Table I, weighed portions of the aluminum solution were mixed with portions of the beryllium chloride solution representing from .01 gram to .10 gram of the oxide, an equal volume of a mixture of strong hydrochloric acid and ether (taken in equal parts) was added to the solution of the mixed chlorides, and the whole was completely saturated with gaseous hydrochloric acid while kept at a temperature of about 15°C . by immersing the receptacle in running water. Ether was added, equal in volume to the aqueous

* Gooch and Havens, this Journal, vol. ii, December, 1896.

aluminum and beryllium solutions originally taken, and the current of gas again turned on until saturation was complete. By this treatment there is present at the end of the saturation a volume of ether equal to that of the aqueous hydrochloric acid introduced and generated. The finely crystalline precipitate of aluminum chloride was caught on asbestos in a filter crucible, washed with a previously prepared mixture of hydrochloric acid and ether in equal parts saturated at 15° C. with hydrochloric acid gas, and dried for half an hour at a temperature of 150° C. It was next covered with a layer of pure mercuric oxide, which had been tested and found to leave no residue on volatilizing, and the crucible was gently heated over a low flame under a ventilating hood and finally ignited over the blast.

TABLE I.

| | Al ₂ O ₃ taken in solution as the chloride. | Al ₂ O ₃ found. | Final volume. cm ³ | Error. |
|-----|---|---------------------------------------|-------------------------------|---------|
| (1) | 0·1046 | 0·1044 | 12 | 0·0002— |
| (2) | 0·1046 | 0·1038 | 12 | 0·0008— |
| (3) | 0·1067 | 0·1066 | 12 | 0·0001— |
| (4) | 0·1071 | 0·1063 | 12 | 0·0008— |
| (5) | 0·1059 | 0·1054 | 30 | 0·0005— |

From these results it is obvious that the aluminum chloride may be determined in the presence of beryllium chloride with reasonable accuracy.

The beryllium may be recovered in the filtrate from the aluminum chloride by precipitation with ammonia after nearly complete evaporation of the acid. It was found, however, upon trial that the conversion of the chloride to the oxide without precipitation and filtration may be easily accomplished by treatment with nitric acid and ignition. The results of Table II indicate this clearly. In these experiments weighed portions of the beryllium solution were evaporated just to dryness on a radiator, care being taken not to heat to the volatilizing point of the beryllium chloride, a few drops of strong nitric acid were added, the liquid was evaporated, and the residue heated—at first gently, to break up the nitrate safely and finally on the blast. It was found that this conversion of the beryllium to the nitrate can be carried on in platinum without attacking that metal appreciably, providing care be taken to remove thoroughly all excess of hydrochloric acid before the nitric acid is added to the dry residue.

TABLE II.

| | BeO taken in solution as the chloride. | BeO found. | Error. |
|-----|---|------------|---------|
| (1) | 0·0483 | 0·0481 | 0·0002— |
| (2) | 0·0483 | 0·0483 | 0·0000 |
| (3) | 0·1076. | 0·1085 | 0·0009+ |

In Table III, (1)–(9), are given the results of experiments in which both the aluminum and the beryllium were determined—the former by precipitation as the hydrous chloride and weighing as the oxide after igniting with mercuric oxide: the latter by the conversion of the chloride, through the nitrate, into the oxide. In experiment (10) (made to get a comparison of the methods) the beryllium was recovered by precipitating the hydroxide with ammonia from the partially evaporated solution of the chloride after removing the aluminum.

In experiments (1) to (5), inclusive, the aluminum was determined exactly as previously described; in (6) and (7) the solutions (being originally larger) were concentrated by evaporation previous to the addition of the ether and hydrochloric acid mixture. In experiments (8), (9) and (10), the treatment was varied advantageously by saturating the aqueous solution directly with hydrochloric acid gas before adding an equal volume of ether, and completing the saturation.

TABLE III.

| | Al ₂ O ₃ taken in solution as the chloride. | Al ₂ O ₃ . | Error. | Final volume. | BeO taken in solution as the chloride. | BeO found. | Error. |
|------|---|----------------------------------|---------|-------------------|--|---------------|---------|
| (1) | 0·1059 | 0·1058 | 0·0001— | 12 ^{cms} | 0·0198 | 0·0204 | 0·0006+ |
| (2) | 0·1053 | 0·1044 | 0·0009— | 12 | 0·0194 | 0·0196 | 0·0002+ |
| (3) | 0·1065 | 0·1059 | 0·0006— | 12 | 0·0197 | 0·0205 | 0·0008+ |
| (4) | 0·1068 | 0·1060 | 0·0008— | 12 | 0·0199 | 0·0207 | 0·0008+ |
| (5) | 0·1049 | 0·1047 | 0·0002— | 12 | 0·0198 | 0·0208 | 0·0010+ |
| (6) | 0·1060 | 0·1057 | 0·0003— | 12 | 0·0977 | 0·0969 | 0·0008— |
| (7) | 0·1064 | 0·1063 | 0·0001— | 12 | 0·1085 | 0·1084 | 0·0001— |
| (8) | 0·1046 | 0·1038 | 0·0008— | 30 | 0·1083 | 0·1087 | 0·0004+ |
| (9) | 0·1051 | 0·1048 | 0·0003— | 30 | 0·1071 | 0·1078 | 0·0007+ |
| (10) | 0·1076 | 0·1075 | 0·0001— | 30 | 0·1086 | 0·1094 | 0·0008+ |

These results are plainly very good.

The manipulation of the process is not difficult. The gaseous hydrochloric acid is most conveniently produced by the well known method of treating with strong sulphuric acid in

regulated current a mixture of strong aqueous hydrochloric acid and common salt. A platinum dish hung in an inverted bell-jar, provided with inlet and outlet tubes through which the current of water for cooling is passed, makes the best container for the solution to be saturated with the gas. It is advantageous to arrange the filtration upon asbestos so that the filtrate and washings may be caught directly in the crucible (placed under the bell-jar of the filter pump) in which the subsequent evaporation is to be effected. The heating of the strong acid solution must be gradual and conducted with care to prevent mechanical loss by a too violent evolution of the gaseous acid.

It only remains to thank Professor Gooch for kind suggestions and advice.

ART. XVI.—*Igneous Rocks of the Leucite Hills and Pilot Butte, Wyoming*; by WHITMAN CROSS.

[Published by permission of the Director of the U. S. Geological Survey.]

CONTENTS.

| |
|--|
| Introduction. |
| Rocks of the Leucite Hills. |
| The Rock of Pilot Butte. |
| Chemical Composition of the Rocks Described. |
| Classification and Nomenclature. |
| Inclusions in the Leucite Hills Rocks. |

Introduction.

IN 1871, in the course of the geological explorations along the 40th parallel, S. F. Emmons found the first leucite-bearing rock to be discovered on the American continent in a small group of hills in southwestern Wyoming, which received on this account the name of the Leucite Hills. The description of the locality given by Mr. Emmons in the reports of the Fortieth Parallel Survey* is very brief, being based upon reconnaissance observations made before the unusual interest attaching to the rocks of the region had been ascertained. A petrographical description of the leucite rock in question is contained in the report by Prof. F. Zirkel† upon the microscopical characters of the rocks of the 40th Parallel collection.

As far as I am aware no further description of the leucite rocks of Wyoming appeared until J. F. Kemp's communication upon them was presented to the Geological Society of America, in December, 1896.‡ The material described by Kemp was much better illustrative of the variation existing in the Leucite Hills lavas than was that examined by Zirkel. He also had specimens of the singular rock from Pilot Butte, a point situated some miles west of the Leucite Hills. Zirkel does not describe the Pilot Butte rock, but a short account of it is given by Emmons.§ The specimens from Pilot Butte in the 40th Parallel collection, preserved in the National Museum, are like the material obtained by Kemp and myself, and Emmons's megascopical description clearly applies to them; but his statements of their microscopical constitution indicate that a no longer explicable confusion of thin sections led him to describe the rock of Pilot Butte as a plagioclase-bearing trachyte, whereas it is entirely free from feldspar.

Major John W. Powell also visited Pilot Butte in the course

* Vol. ii, Descriptive Geology, 1877, pp. 236-238.

† Vol. vii, Microscopical Petrography, 1876, pp. 259-261.

‡ Published in Bull. Geol. Soc. Amer., vol. v, 1897, pp. 169-182.

§ Reports of the Fortieth Parallel Survey, vol. ii, 1877.

of his geological explorations, and collected specimens identical in character with those described by Kemp and in the course of the present paper. For the opportunity of examining Major Powell's specimens I am indebted to Mr. J. S. Diller, in whose hands they had been placed for study.

The observations communicated in the following pages are based upon a trip to the Leucite Hills made a number of years ago. That their publication has been so long deferred is partly due to the pressure of other work, and largely to a desire—thus far not realized—to revisit the region before publication in order to greatly extend my observations. In view of the unusual interest attaching to the rock types to be described, I feel that an explanation of the inadequate character of my field observations in the Leucite Hills is not out of place. The visit to this locality was made late in the fall of 1884, with an assistant, W. B. Smith, for the express purpose of collecting a large number of specimens of the leucite rock for the "Educational Series" then being assembled by the Geological Survey. No mineralogical variation in the rocks of the region was indicated by the descriptions of Emmons and Zirkel, and, as none could be detected by the naked eye, such variation was not suspected at the time of my visit. The weather became very stormy soon after our arrival, and snow covered the hills a part of the time. For these reasons my observations do not make plain the field relations of the types collected, whose differences were chiefly evident only after microscopical study. Pilot Butte was visited during one of the terrific sand storms for which this part of Wyoming is noted at certain times of the year, and I was only able to gather specimens of the rock without determining definitely the manner of its occurrence.

Occurrence of the Rocks of the Leucite Hills.

Inasmuch as Professor Kemp has so recently presented a general sketch of the Leucite Hills, together with illustrations from photographs and an outline map of the region, I shall in the main content myself in the following pages with some details in regard to the portions of the area visited in which the rocks to be described were found.

The mesa.—The principal area of leucite-bearing rocks is in a low, irregular mesa of perhaps 15 square miles in extent, bounded by a scarp usually not more than 50 feet in height, representing the surface flow of the leucite rock resting, for the most part, on upper Cretaceous strata. On the north and northeast of this mesa are several isolated hills, flat-topped, with scarps, which were once connected with the principal mesa. Of these outlying hills only two were visited, namely, Orenda Butte and North Table Butte.

This mesa, caused by the leucite-bearing lava, has a gently undulating surface of bare rock in many places, with scanty vegetation here and there, the sage bush being most common. Several small cones rise above the mean level. There are six of these cones, according to Kemp, who gives illustrations of some of them in his paper. On the eastern side of the mesa, in one of the indentations, is a spring, known to my teamster and to the stockman who lived there as the "15-mile spring." Kemp refers to it as "the spring 10 miles from the railroad at Almond Station." In the vicinity of this spring, which was my headquarters and where the specimens for the Educational Series were collected, the lava of the scarp is somewhat variable in texture, the greater part being vesicular in some degree, with massive rock occurring here and there. It is in regard to the relation between this massive variety, which corresponds most closely to the type described by Zirkel, and the porous form, that my field observations are unfortunately so imperfect. But little of the massive rock was seen, and then nothing was observed to indicate that the two types belonged to different flows. On this account, and from the chemical identity of the two rocks, I am at present inclined to regard the leucitite of Zirkel's report as a part of the same flow that is predominantly a more or less vesicular sanidine-leucite rock, described in succeeding pages as *orendite*.

I did not explore the mesa except near the eastern end, where the rock of the surface was markedly porous and in places nearly a pumice. Two of the cones were visited, and my notes record that these consisted mainly of pumice. This statement is at variance with that of Kemp that all these cones are of solid rock and due, in his opinion, to the welling-up of lava above volcanic conduits. It is of course possible that the cones are not all of the same character.

Outlying buttes.—North-of-east and about two miles from the mesa is an outlier, known as Spring Butte to my local authorities, but described by Kemp as Orenda Butte, a name also found on the Land Office map. The inclusions noticed in the lava at this point will be specially described in a later section.

A few miles north of the principal mesa is a remnant of the former sheet in what is known as North Table Butte. We visited this point, reaching the summit through a cleft in the scarp on the northern side. The butte rises about 750 feet above the valley at its northern base, but only some 50 feet of lava is present. The rocks of the scarp vary as in the mesa to the south, but are lighter colored. Pumiceous material was found on the top of the butte. Its summit is considerably above the level of the mesa to the south, but whether this is

due to original unevennesses of the surface upon which the lava was poured out, or to subsequent faulting, was not ascertained. In the depression between this butte and the principal mesa two or three small cones were seen, each with a vertical column of rock rising from its apex. It is to be inferred that these are volcanic plugs, similar to the Boar's Tusk, shortly to be described.

Occurrence of potash nitre.—On the eastern side of the gap through which the top was gained, a cavity or recess with overhanging roof, of irregular shape, several feet in length and depth, was found in nearly massive rock. It was fully exposed to the prevalent northwesterly breeze, and rain could penetrate to the inner wall only when driven by very strong winds. In this sheltered space was found a very unusual mineral in a rather coarse, granular aggregate, and of sufficient mass to allow collection of specimens several inches in diameter. It seemed to occur as a partial crust to the cavity and as a filling for irregular fissures which extended downward and backward into the body of the rock. A columnar mass several inches in diameter connected roof and floor of the recess at one point where they were not less than one foot apart. Fragments of rock were attached to the column, and its stalactitic shape is probably an accident. This white granular substance was analyzed by L. G. Eakins and found to be essentially nitrate of potash. The exact result is given below :

Analysis of nitre, etc.

| | | |
|--------------------------------------|-------|------------------|
| K ₂ O | 44·91 | } = 96·40 nitre. |
| *N ₂ O ₅ | 51·49 | |
| CaO | 1·09 | } = 3·31 gypsum. |
| SO ₃ | 1·59 | |
| H ₂ O | ·63 | } = 0·16 halite. |
| Na | ·07 | |
| Cl | ·09 | |
| ————— | | |
| 99·87 | | |

It is regretted that the nature of this substance was not recognized in the field, in order that closer observations of its occurrence might have been made. As far as known there is nothing to indicate the derivation of this nitre from organic substances of any kind, yet such an origin is either evident or assumed as probable for all other occurrences of natural nitrates of which I find mention in manuals of mineralogy. This occurrence is, however, entirely different from all others of which notice has been found in literature. While extended

* N₂O₅ calculated for K₂O.

discussion of the genesis of this deposit of nitre is at present useless, it may well be pointed out that ammonia gas is a common exhalation product of volcanoes in their fumarolic stage, and that ammonium chloride, salammoniac, is deposited in clefts, fissures, or tubular cavities of lavas at Vesuvius, *Ætna*, Solfatara, Hecla, and other volcanoes. The lavas of the Leucite Hills contained fluorine, chlorine, and sulphurous compounds, as will be shown by the rock analyses, and it is certainly a noteworthy coincidence, if nothing more, that one of the best known occurrences of salammoniac is in the leucitic lavas of Vesuvius, rich in potash.

As regards the occurrence of North Table Butte, there is no special reason to assume a volcanic conduit at this point, yet this occurrence would seem to suggest such a channel at no great distance.

Other minerals were not seen in this cavity, the nitre being deposited directly on the rocks. The presence of soda-nitre at the Boar's Tusk, described below, renders this occurrence all the more interesting. Although the nature of the nitre was not definitely recognized at the time of its discovery, the peculiar astringent taste was noted then and the true character as a nitrate was speedily established. Specimens of this nitre may be seen in the National Museum.

The Boar's Tusk.—Northwest of the Leucite Hills, in the valley of Killpacker Creek, about 20 miles north of Rock Springs, there is an interesting volcanic plug known as the Boar's Tusk, a column of leucite rock rising about 300 feet above the valley. Débris and the Eocene sandstones pierced by the plug form a cone reaching to nearly half the height on all sides. An outcrop of horizontal sandstone is to be seen near the base of the cone. Seen from the east or west the Tusk is broader and much less regular than in the view from the south.

The mass of the column is partly a compact breccia and partly massive rock. On the southern and western sides is a breccia made up of the same rock type which in massive form reaches to the top of the column on the east and north, and is apparently separated from the breccia by fissures. The breccia is coarse or fine-grained, containing fragments several feet in diameter. The principal component is always the leucite rock, but mingled with it are numerous fragments of sandstones, clays baked very hard, oolitic limestone, shell limestone, and a coarse-grained feldspathic rock.

In several places where the breccia was open and cavernous a scanty white coating was observed on protected rock faces. Unfortunately the character of this substance was not suspected, and only a single small specimen was with difficulty

procured for analysis. It proves to be soda-nitre containing a little potash, as shown by the analysis below, made by L. G. Eakins:

Analysis of soda-nitre.

| | | | |
|-------------------------------------|--------|--|--|
| Na ₂ O | 32.09 | | |
| K ₂ O | 4.97 | | |
| N ₂ O ₅ | 61.58* | | |
| CaO | .24 | | |
| SO ₃ | .33 | | |
| H ₂ O | .68 | | |
| Cl | trace | | |
| | 99.89 | | |

}

87.98 NaNO₃.

10.66 KNO₃.

0.71 gypsum.

.54 water.

The discovery of soda-nitre in anything resembling this occurrence has not been announced before, as far as I can ascertain. The similarity in the conditions of occurrence of the two nitrates described above adds to the strength of the hypothesis that both are intimately related in origin to the peculiar magna of this region. Yet it is possible that organic matter from clefts above inhabited by birds or small animals might have furnished the nitrogen for this nitre.

The rock of the Boar's Tusk is nearly identical with the massive variety of the Leucite Hills, and the conclusion seems unavoidable that the Tusk is a plug occupying one of the conduits through which the potash-rich magna rose to the surface.

Wyomingite.

From the Leucite Hills proper.—The only rock type from this locality described by Zirkel or Emmons is, according to the experience of both Kemp and myself, much less abundant than the next variety to be discussed. From reasons to be more fully presented later on, I believe that this rock should receive a special name, and hence it is proposed to call it *wyomingite*, from the State in which it occurs. Although this original type has been described in some detail by others, it seems best to discuss it still more fully in this place in connection with the allied rocks, particularly since this special name is proposed for it. It is a massive rock, of a peculiar, dull reddish-gray tone, exhibiting a marked schistosity through the nearly parallel arrangement of the abundant, small, reddish mica flakes. This mica, which is the only megascopically recognizable constituent, is developed in very thin hexagonal or rhombic plates† which, under a hand lens often show a

* Calculated for Na₂O + K₂O.

† Zirkel says that the mica does not occur "in six-sided or rounded plates, but in the form of remarkably long stripes and dashes, such as have seldom been observed." In all the rocks of the Hills which I have examined the mica presents a more or less distinct crystal form.

delicate play of colors. The largest leaves are only 2^{mm} or 3^{mm} in diameter, and while some are of microscopic size, none belong properly to the groundmass, which consists of leucite and diopside, with but small amounts of apatite and other variable elements to be mentioned.

The mica is of remarkably weak absorption and pleochroism, the latter ranging only from a pale salmon-pink to pale yellow. Basal sections show the exit of a negative bisectrix and an optic angle which is large for mica, reaching about 35° according to a measurement made by Prof. L. V. Pirsson, who has described a very similar mica in one of the leucite rocks of Montana. Sections normal to the base often exhibit a polysynthetic basal twinning, and by this means one can readily establish the fact of a measurable angle, reaching as much as 3°, between *a* and *c*. Inclusions, excepting a few of glass, are very rare in these mica plates, and pure material for chemical analysis was procured with the Thoulet solution by W. F. Hillebrand, who analyzed it with the result to be given later on. From the analysis it is plain that this mica is a phlogopite, and as far as I can ascertain it is the first definitely known occurrence of this variety in true igneous rocks. Both Zirkel and Kemp have alluded to the peculiar character of this mica, which they called biotite.

The groundmass holding the phlogopite crystals is largely made up of leucite, with many very small pale-green or colorless microlites of diopside between them. In all the sections I have examined the number of leucites with distinct crystal planes is very small compared with the multitude of minute roundish anhedral. Those individuals with icositetrahedral form are slightly larger than the anhedral, and they are further distinguished by a zone of minute inclusions and often by re-entering angles on the planes of the crystal, this being the nearest observed approach to a skeleton development. The roundish grains usually vary between .01^{mm} and .05^{mm} in diameter. No trace of double refraction has been seen.

A variability in the development of leucite in different places is indicated by the description of Zirkel, who refers to the sharp crystal form of each of the minute individuals. From the comparatively low amount of sulphuric acid in the rock, it seems that but little noselite can be assumed to be present, although it must be developed quite abundantly in the similar rock of the Boar's Tusk, and is there indistinguishable from leucite.

The microlites of the typical wyomingite are for the most part too minute for certain identification except by comparison with the few larger ones and with the very distinct diopside of other rocks to be described. From the amount of phosphoric

acid found by analysis, these rocks are shown to be richer in apatite than would be inferred from microscopical examination. The apatite is seen occasionally in rather large grains, but must be chiefly developed in small prisms difficult to distinguish from diopside needles.

By the close crowding together of the leucites and the occurrence of diopside needles between them, it would seem as if there could be very little glassy base present; but in places there is a filmy globulitic substance between the leucites, and as will appear from the discussion of the chemical analyses, there are grounds for supposing that there must be a highly siliceous residue in the form of a colorless glass forming a base for the minute crystals. Careful reëxamination of this rock, after the difficulties in interpreting the analyses were fully shown, convinces me that there is a much larger amount of residual glass between the minute leucites and the felt of diopside and apatite needles than was at first suspected. The leucites do not often interlock with angular projections, and although the diopside needles fill in the gaps to a large degree, there is some glass undoubtedly present.

The dense wyomingite of the above character undoubtedly grades with all intermediate stages into the rock containing much sanidine, but several specimens were collected showing no feldspar except in a somewhat questionable interstitial form. Probably all thin sections exhibit a few minute leaves of dark-brown biotite containing so much ferritic matter, seemingly a product of magmatic resorption, as to obscure the optical properties. Kemp mentions a few grains of hauynite: magnetite, titanite, pyrite, and other accessory minerals seem entirely wanting in the pure wyomingite.

Both Zirkel and Kemp have represented the microstructure of this rock, and their descriptions agree with the above in most particulars. Chemical analyses of the wyomingite will be given in a later section of this article, together with those of the other types and a discussion of the systematic position of all the rocks described.

From the Boar's Tusk.—The specimens of massive rock from this volcanic neck are much like the type already described, with a slightly larger amount of phlogopite and a still more pronounced schistose structure than was observed at any point in the Leucite Hills proper. The groundmass is, as a rule, of a more or less distinct dull-greenish shade, and there are some flat, drawn-out vesicles, rarely containing any secondary minerals.

The breccia in the southern part of the neck is chiefly made up of wyomingite fragments less than 2 inches in diameter, and they seem to all belong to the same variety as the massive

rock. The matrix is a finer dust of the same origin, and it is generally pale-green in color. Fragments of sandstone, limestone, oolite, and some granular rocks rich in dark silicates were observed.

Microscopical examination reveals leucite, diopside, and phlogopite as the important minerals, with a few small biotite leaves and apatite in unusually large prisms, with axial inclusions. Both leucite and diopside are developed in much more distinct crystals than in the preceding rock. A few large irregular grains of augite and phlogopite intergrown seem probably to belong to some of the rocks appearing in fragments.

Leucite is developed in well-formed crystals which include many minute diopside needles. They reach $.05^{\text{mm}}$ in diameter and are very abundant, exceeding all other constituents in amount. Diopside occurs in short, colorless prisms, seldom twinned, of hexagonal cross-section through the suppression of one pinacoidal plane.

These constituents lie in a very subordinate cloudy-gray base, which obscures the leucites except in the thinnest places. By high powers a faint greenish color seems visible, and as there is some double refraction in the mass it appears probable that there is a microlitic development of diopside and a scanty glass base. No magnetite was seen in the rock.

Orendite.

The principal rock of the Leucite Hills, whose chief constituents are leucite and sanidine, with phlogopite, amphibole and diopside, seems to me worthy of a special name, and it is proposed to call this rock and its equivalents elsewhere *orendite*, after the prominent butte on the northeastern side of the Hills, where it is well developed. The reasons for this proposition and the scope of its suggested application are presented fully in a subsequent section, after discussion of the chemical analyses.

Megascopical description.—The orendite is characterized by the same dull reddish-brown or gray tones seen in the wyomingite, and its only distinct megascopic constituent is phlogopite. All the specimens collected were subordinately vesicular, but that is of course not an essential feature. On North Table Butte the rocks are much lighter in color than was observed elsewhere, being yellowish to straw-colored. Under a lens the mass of the rock seems almost saccharoidal in texture, showing a white granular mass colored by a small amount of indistinct pinkish or yellowish matter.

In most cases a few dull grains of orthoclase will be seen, but they are corroded and show the same character as the feldspar of larger included rock fragments to be described later. These are therefore not regarded as phenocrysts properly

belonging to the rock. By close examination under a lens small glistening cleavage surfaces may occasionally be seen, which are interrupted by many minute particles, producing a poikilitic structure. These surfaces belong to sanidine.

The pores of the rock are always irregular in shape, ordinarily not drawn out in any prevalent direction, showing divergent smooth-walled arms. They vary from 1^{mm} in length downward, and are also developed in variable amount. In some places the cavities constitute half the bulk of the rock.

With a hand lens of high power the walls of the cavities are often seen to be coated by a network of very pale-yellowish needles, and in rare cases they project free into the pores. These needles are of the amphibole described below. A far more common filling of the pores is hyalite, in its characteristic clear globular forms. With the hyalite, and generally embedded in it, is a white mineral in rude bundles, opaque, and so poorly developed that it has not been determined.

Mineral constitution and structure.—On microscopical study it is found that this rock consists of leucite and sanidine in predominant amount as compared with the ferro-magnesian-lime elements, phlogopite, amphibole and diopside. Apatite and rutile (?) are accessory minerals, but no magnetite, ilmenite or pyrite occurs. Biotite is developed, as in the wyomingite, in a few much resorbed flakes. It is probable, from examination of the chemical analyses, that free silica in the form of tridymite or opal is present, but aside from the filling of cavities spoken of above neither substance has been identified.

In quantitative development leucite and sanidine vary considerably, now the one, now the other seeming to predominate, but in general they are nearly equal in amount. Of the heavier silicates phlogopite is the most important, while the other two seem to vary with the leucite and sanidine. The amphibole is developed approximately in proportion to the sanidine, and diopside corresponds to leucite. No amphibole has been found in the sanidine-free wyomingite.

The peculiar association of minerals in these rocks leads to several interesting microstructures. Phlogopite appears to have formed first and is almost wholly free from inclusions. Leucite and sanidine are as a rule grouped in separate patches or areas, the former in swarms of minute anhedra exactly like those of the wyomingite. Sanidine occurs in aggregates of stout, square prisms, much larger than the leucites, but still seldom exceeding 1^{mm} in length.

Diopside is mainly developed in minute needles and micro-lites, a large share of which are included in the sanidines, producing a poikilitic structure which may occasionally be detected megascopically. The remainder of the diopside occurs

between other grains, and the leucites are almost free from inclusions.

The amphibole seems to be the last mineral to form, and it varies in development. In the angular spaces between the sanidines the yellowish amphibole occurs exactly as does augite in the ophitic diabases, while in the leucitic areas the same amphibole is developed in stout prismatic anhedral enclosing the leucites, just as ægirine or ægirine-augite does the nephelites in many phonolites. In occasional spots and adjacent to the pores of the rock the minerals are less intimately intergrown. Leucite is sometimes found included in sanidine, but more frequently the separation is very sharp.

There are thus in this rock two kinds of micropoikilitic structure, a curious separation of the analogous silicates, leucite and sanidine, and a porphyritic structure through the prominence of phlogopite leaves.

Sanidine.—The glassy feldspar of this rock was mentioned by Kemp, who noted a rare development of simple twinning and an extinction reaching a maximum of 10° from the length axis. The rude crystal form renders accurate orientation difficult, but since my own observations agree with Kemp's as regards the angle of extinction, and as it is always the axis of elasticity which lies near the longer axis of the crystal, it seems proper to interpret these prisms as developed parallel to the clinoaxis. As the terminal faces of such crystals are commonly domatic planes, the prevalent rectangular outlines are explained. The twinning observed must be after the Carlsbad law, as extinction is parallel to the twinning plane.

No microscopic intergrowths with other feldspars have been seen, a natural consequence of the low soda contents of the magma. Cleavage is seldom well marked, a fact which may be due in part to the multitude of microlitic inclusions, serving to hold the cleavage plates together as in the mica of the Pilot Butte rock (p. 128).

Amphibole.—Kemp does not mention the presence of amphibole in the rocks described by him, which are otherwise like the orendite. It is indeed very variably developed in my sections, some 40 in number, and is not often seen in prisms well adapted for study. In its optical characters this amphibole is unlike any of which I can find record. Its general determination as an amphibole rests upon the strong cleavage parallel to a prism of about 124° and the observed habit of the mineral.

While usually irregular in outline, a few cross-sections have been found which agree with amphibole in the angles of the prism, cleavage, and existence of pinacoidal planes. The terminal planes are very rarely developed, and then seem to be pyramid and dome.

The optical properties are unlike those of any mineral with which I am acquainted. Extinction seems to be always parallel to the length axis. The optical scheme is as follows:

$a=a$, pale yellow; $b=b$, red; $c=c$, bright yellow. The reddish tones are very similar to those of hypersthene and increase rapidly in intensity with increasing thickness. Absorption: $b > c > a$.

Needles scraped from the cavities have the same character as the embedded mineral. In the powder obtained from one cavity there was found a flake apparently representing a section normal to the prism as indicated by cleavage, prism angle, and pleochroism. Examination of this plate in convergent polarized light showed the figure of an almost uniaxial mineral, the arms barely separating in the 45° position.

Other constituents.—Phlogopite and leucite are so identical in development with the forms described for the wyomingite that no further comment is necessary. Apatite appears in a number of clear, more or less irregular prismatic grains, with axial inclusions; but the analysis indicates a much larger amount of this mineral in the rock than one would infer from the sections. The mineral mentioned above as rutile (?) occurs in minute yellow needles of round prism outline, with strong single and double refraction and extinction apparently parallel to prism, though absorption in this direction is so strong as to obscure extinction.

The Rock of Pilot Butte.

Occurrence.—In the words of Mr. Emmons,* “Pilot Butte is a curious little conical castle-like mound, rising about 400 feet above the surface of the plateau country, in the angle between Bitter Creek and Green River to the north of the [Union Pacific] railroad. It is a rudely circular mass, scarcely 1000 yards in diameter, having abrupt faces on all sides, and composed of a rather singular volcanic rock unlike any other found within the limits of the survey. It is evident that the soft Green River [Eocene] Tertiaries, which once surrounded and covered it, must have been eroded away. . . .”

The plateau above which the butte rises is separated from the principal mesa of the Leucite Hills by the broad shallow valley of Killpacker Creek, and no other mass of volcanic rock is known nearer than the Leucite Hills, some 15 miles to the eastward. No observations are reported by either Emmons or Kemp indicating beyond question the character of this mass. No contacts seem to have been found. At the eastern base, where I gathered my material, talus effectually concealed the contact, and such may be the condition on all sides.

* Reports of the Fortieth Parallel Survey, vol. ii, Descriptive Geology, 1877, p. 238.

In view of the somewhat porous texture, the fluidal structure, and the presence of a glassy base in the rock of Pilot Butte, it is most plausible to regard the mass as a remnant of a surface flow.

Description.

Megascopical appearance.—In general the megascopical descriptions of the Pilot Butte rock given by Emmons and Kemp in their cited publications apply to my own material. The rock is ashen-gray, yellowish, or greenish, and generally porous in a subordinate degree. As the pores of the gray rock are almost free from secondary minerals, while those of the yellowish variety contain white minerals of zeolitic character, the former seems probably the normal color of the fresh rock. The pores are small, very irregular in form, and are but slightly drawn out in any direction. The fractured faces are quite rough and uneven.

To the unaided eye the rock is largely dull and felsitic, with numerous small reddish specks showing strong cleavage. These are somewhat less than 1^{mm} in diameter, and all belong to phlogopite. The uniform distribution of these mica grains is very noticeable in all specimens I have seen. Occasional smooth surfaces, when examined by a hand lens, show minute pale-green prisms in a network. These are doubtless diopside, the principal constituent of the rock.

Constitution.—On microscopical examination it appears that colorless diopside, phlogopite, and probable perovskite, are the chief minerals of this rock, with a glassy base of brownish color, which according to the analysis must contain silica, alumina, and the alkalis in nearly the proper ratio to have caused the formation of leucite had the mass entirely crystallized.

The development of diopside in this rock is very similar to that described for the same mineral in the Wyomingite of the Boar's Tusk. It appears in colorless, doubly terminated prisms less than 1^{mm} in average length, more or less markedly arranged in streams. Cross sections show common development of the prism and orthopinacoid, and occasional twinning parallel to this latter plane. An analysis of diopside is to be given later on.

The next most important mineral is mica, which is very similar in many respects to that in the rocks of the Leucite Hills, but exhibits certain peculiarities of development worthy of notice. Instead of being well crystallized and free from inclusions, as in the other types, the phlogopite of the Pilot Butte rock occurs in roundish grains averaging 0.8^{mm} in diam-

eter, holding the diopside microlites and perofskite grains in as great numbers as does the residual glass. The streams of diopside prisms pass without any change through the phlogopite grains, and a very pronounced form of the micropoikilitic structure is thus produced. The anhedral phlogopite have very uneven, ragged outer borders, and show none of the usual tendency to develop in plates parallel to the cleavage, and this parting is here much less strongly developed than in any other occurrence of mica known to me. The cleavage lines appear in this case like those in feldspar or amphibole, being sharp and clear, but by no means so numerous as is usual.

That this peculiarly developed mineral is mica seems to me sufficiently established by the following data: The color is almost identical with that of the phlogopite. Sections showing strongest cleavage polarize very brilliantly and extinguish parallel to the cleavage, as far as can be ascertained. The brilliant polarization of most sections is very striking, but a few may be found where the maximum color is the pale-blue of melilite. Such sections show in convergent light the exit of a negative bisectrix, the optical angle being large. The plane of the optical axes is parallel to a sharp boundary line which was observed in one case. The pleochroism is even fainter than in the mica of the leucite rocks, but by comparing the sections showing best cleavage with those exhibiting the optical figure the following optical scheme was made out:

- a yellow, with pinkish tinge occasionally, lies normal to the cleavage, i. e. near *c*.
- b pink, parallel to *b*.
- c straw yellow, nearly parallel to *a*.

This orientation is the same as that of the phlogopite in the leucite rocks.

Perofskite and magnetite are developed in minute crystals of 0.02^{mm} to 0.03^{mm}, and the former is much the more abundant. The grains referred to perofskite are roundish crystals of very high index of refraction, yellow-brown color, isotropic, and only those included in the phlogopite are entirely fresh, the rest showing a dull white cloudy alteration product which causes them to stand out in marked contrast to the magnetites when the section is viewed by reflected light. Some very minute needles of apparently yellowish color may be seen in the phlogopite, with a high power. These seem most plausibly referred to rutile, though no regular arrangement was observed.

The glass base of the rock is isotropic but not clear and transparent, being clouded by indistinct globulites and microlites which seem to have a yellowish-green color, or at least

that is the tone of the mass where they are developed. Nearly one-third of the rock is amorphous, but the multitude of minute crystals embedded in it, the cloudy zone about the perofskites, and the globulitic particles mentioned, make this base transparent only in the thinnest sections. As will be shown later on, this glassy base contains silica, alumina, and the alkalis, in nearly the ratio found in leucite.

For this rock, consisting of diopside and phlogopite in predominant degree, and with leucite or a glassy base corresponding to it, I propose the name *madupite*, from the Shoshone Indian *madúpa*, meaning sweetwater,* the name of the County in which the locality is situated. A definition, with discussion of the relationships of madupite, will be found in a later section of this article.

Chemical Composition of the Rocks Described.

In the table below are given several analyses of wyomingite, orendite and madupite, of the phlogopite and diopside isolated from these rocks, and of a few related rocks for purposes of comparison. Under I is an analysis by Pawel, made for Zirkel† and published in his German résumé of the 40th Parallel report; II is by R. W. Woodward, and was published by Emmons‡ (I and II were presumably made on the same material); III is of wyomingite from the Boar's Tusk; IV of wyomingite from the 15-mile spring; V is of orendite from the 15-mile spring; VI of orendite from North Table Butte; VII of madupite from Pilot Butte; VIII of phlogopite from wyomingite of Boar's Tusk; IX of diopside from wyomingite and madupite. The analyses III to IX, inclusive, are all by W. F. Hillebrand, whose many painstaking and reliable analyses of igneous rocks form a most important contribution to petrography. Analysis X, by H. N. Stokes, is of "leucitite" from the Bearpaw Mountains, Montana, described by Weed and Pirsson (this Journal (4), vol. ii, 1896, p. 147). No. XI, by E. B. Hurlburt, is of missourite, also from the Highwood Mountains and described by Weed and Pirsson (this Journal (4), vol. ii, 1896, p. 321).

* According to information kindly given me by Mr. W. J. McGee, of the Bureau of Ethnology.

† Ueber die Krystallinischen Gesteine längs des 40^{ten} Breitgrades in Nord-west-Amerika. Berichte der k. sächs. Gesellschaft der Wissenschaften, Jan., 1877, p. 239.

‡ Reports of the Fortieth Parallel Survey, vol. ii, Descriptive Geology, 1877, p. 237.

TABLE OF ROCK ANALYSES.

| Sp. Gr. | Wyomingite. | | | | Orendite. | | Madu- pite. | Phlogopite. | Diopside. | Leucite, Montana. | Missourite, Montana. |
|--------------------------------|-------------|-------|-----------------|-----------------|-----------------|-----------------|----------------|-------------|-----------|----------------------|-------------------------|
| | I. | II. | III. | IV. | V. | VI. | | | | | |
| | | | 2-779 13° C. | 2-627 30° C. | 2-686 23° C. | 2-699 19° C. | | | | | |
| SiO ₂ | 56.30 | 54.42 | 50.23 | 53.70 | 54.08 | 54.17 | 42.65 | 42.56 | 50.86 | 46.51 | 46.06 |
| TiO ₂ | --- | --- | 2.27 | 1.92 | 2.08 | 2.67 | 1.64 | 2.09 | α3.03 | .83 | .73 |
| ZrO ₂ | --- | --- | --- | --- | --- | .22 | --- | --- | --- | --- | --- |
| Al ₂ O ₃ | 12.63 | 13.37 | 11.22 | 11.16 | 9.49 | 10.16 | 9.14 | 12.18 | none | 11.86 | 10.01 |
| Ce ₂ O ₃ | --- | --- | .03 | none | ? | --- | .11 | --- | --- | --- | --- |
| Di ₂ O ₃ | --- | --- | .10 | .04 | .07 | .05 | .07 | .73 | --- | --- | --- |
| Cr ₂ O ₃ | --- | .61 | 3.34 | 3.10 | 3.19 | 3.34 | 5.13 | 2.73 | 1.19 | 7.59 | 3.17 |
| Fe ₂ O ₃ | 6.92 | 3.52 | 1.84 | 1.21 | 1.03 | .65 | 1.07 | .90 | 1.82 | 4.39 | 5.61 |
| FeO | --- | --- | .05 | .04 | .05 | .06 | .12 | --- | .03 | .22 | tr. |
| MnO | --- | --- | 5.99 | 3.46 | 3.55 | 4.19 | 12.36 | .20 | 23.32 | 7.41 | 10.55 |
| CaO | 5.63 | 4.38 | .24 | .19 | .20 | .18 | .33 | --- | --- | .16 | .20 |
| SrO | --- | --- | 1.23 | .62 | .67 | .59 | .89 | 1.00 | --- | .50 | .32 |
| BaO | --- | 6.37 | 7.09 | 6.44 | 6.74 | 6.62 | 10.89 | 22.40 | --- | 4.73 | 14.74 |
| MgO | 5.08 | 10.73 | 9.81 | 11.16 | 11.76 | 11.91 | 7.99 | 10.70 | 4.2 | 8.71 | 5.14 |
| K ₂ O | 11.50 | 1.60 | 1.37 | 1.67 | 1.39 | 1.21 | .90 | .44 | .76 | 2.39 | 1.31 |
| Na ₂ O | 2.21 | tr. | tr. | tr. | tr. | tr. | tr. | tr. | --- | --- | --- |
| Li ₂ O | --- | --- | .93 | .80 | .79 | .52 | 2.04 | --- | --- | 1.10 | --- |
| H ₂ O (b) | --- | 2.76 | 1.72 | 2.61 | 2.71 | 1.01 | 2.18 | 2.35 | .31 | 2.45 | 1.44 |
| H ₂ O (c) | --- | --- | 1.89 | 1.75 | 1.35 | 1.59 | 1.52 | --- | --- | .80 | .21 |
| P ₂ O ₅ | --- | --- | .74 | .06 | .29 | .16 | .58 | .06 | --- | tr. | .05 |
| P ₂ O ₆ | --- | --- | .03 | .03 | .04 | .06 | .03 | --- | --- | .04 | .03 |
| SO ₃ | --- | --- | .50 | .44 | .49 | .36 | .47 | --- | --- | tr. | --- |
| Cl | --- | --- | --- | --- | --- | --- | --- | 2.46 | --- | --- | --- |
| Fl | --- | 1.82 | --- | --- | --- | .49 | --- | --- | --- | --- | --- |
| CO ₂ | --- | --- | --- | --- | --- | --- | --- | --- | --- | --- | --- |
| O for Fl | 100.27 | 99.58 | 100.62 | 100.40 | 99.97 | 100.21 | 100.11 | 100.80 | 99.16 | 99.73 | 99.57 |
| | --- | --- | .22 | .19 | .21 | .17 | .20 | 1.03 | --- | --- | --- |
| | --- | --- | 100.40 | 100.21 | 99.76 | 100.04 | 99.91 | 99.77 | --- | --- | --- |

a. TiO₂ and P₂O₅; b = below 110° C.; c = above 110° C.; d. With .04 NiO. No. VI contains a trace of nickel.

Discussion of analyses.—It is interesting to note that the older analyses, in spite of the evident inaccuracies, indicate quite correctly the general character of the magmas of the Leucite Hills; but they fail to show the great complexity of constitution which makes these rocks so noteworthy. Few rocks have been shown to contain so many chemical elements in determinable amounts; and in this connection it should be stated that in all probability zirconia was present in all the rocks, but was not tested for in the older analyses, III, IV, V, and VII, which were made several years ago, while VI was made in January, 1897.

From the analyses of phlogopite and diopside it is plain that TiO_2 , Cr_2O_3 , BaO , and Fl are in very large degree contained in the mica, while the first is the only one of these oxides in the diopside. Tests showed that the sulphuric acid was always in the part of the rock soluble in HCl , hence it is certain that barite cannot be present, and the probability appears that noselite is developed to a varying extent in minute crystals not distinguished from leucite in the thin sections. There is an unusually large amount of P_2O_5 in all these rocks, and while a few large apatites may be readily detected under the microscope, it seems probable that much of this mineral is developed with diopside in minute needles not easily recognized. The presence of such a large amount of phosphoric acid here contrasts in a noteworthy manner with the very small amount ordinarily found in phonolites.

It is noteworthy that the rock of the volcanic neck (III) is richer in almost all of the rarer constituents than any other except that of Pilot Butte. It is also higher in magnesia and lower in silica than the others. As for zirconia the suggestion is made that the peculiar amphibole of orendite is perhaps zirconia-bearing, analogous to lăvenite, wöhlerite, and hiortdahlite. If that is the case it seems quite possible that the amphibole contains Ce_2O_3 and Di_2O_3 .

The most striking fact of petrographical interest in these analyses is the almost identical constitution of two rocks, one rich in leucite and free from sanidine, the other with predominant sanidine. The conclusion that chemical composition of a magma does not alone determine whether leucite or sanidine shall be formed, but that this is controlled by conditions of consolidation is unavoidable. As the composition of the amphibole in the orendite is unknown, a satisfactory calculation of analyses V and VI is impossible, but those of the other types afford interesting results.

Taking first the Boar's Tusk wyomingite, the molecular ratio of its constituents is as below; and on assuming that lime is wholly in apatite and diopside, magnesia in diopside and phlo-

gopite, these elements may be calculated out, leaving only silica, alumina and the alkalis in considerable amounts. Alumina is found to be insufficient to combine with the alkalis in leucite or sanidine, but if the SO_3 is present in noselite the alumina is almost exactly sufficient. There is a large excess of silica, enough indeed to have formed sanidine with all the alumina and alkalis.

CALCULATION OF ANALYSIS III.

| Molec. ratio. | Diopside. | Phlogopite. | Noselite. | Leucite. | Apatite. | Residue. |
|----------------------------------|-----------|-------------|-----------|----------|----------|----------|
| SiO_2 ---- 837 | 132 | 127 | 54 | 252 | | 272 |
| TiO_2 ---- 28 | 4 | 5 | | | | 19 |
| P_2O_5 ---- 13 | | | | | 13 | 0 |
| SO_3 ---- 9 | | | 9 | | | 0 |
| Al_2O_3 ---- 110 | | 20 | 27 | 63 | | 0 |
| Fe_2O_3 -- 21 | 1 | 2 | | | | 18 |
| FeO ---- 26 | 4 | 3 | | | | 19 |
| CaO ---- 107 | 64 | | | | 43 | 0 |
| MgO ---- 177 | 68 | 109 | | | | 0 |
| K_2O ---- 104 | | 23 | 14 | 63 | | 4 |
| Na_2O ---- 22 | | | 22 | | | 0 |
| 1454 | 273 | 289 | 126 | 378 | 56 | |
| | | 19.87% | 8.66% | 26.1% | | |

Neglecting the small amounts of substances shown by analysis and not introduced into the above calculation, this rock consists of

| | | |
|-------------------|-------|--------|
| Free silica | 18.7 | } 53.5 |
| Leucite | 26.1 | |
| Noselite | 8.7 | |
| Diopside | 18.8 | |
| Phlogopite | 19.9 | |
| Accessories | 7.8 | |
| | 100.0 | |

The residual amounts form a little magnetite, and there is some titanate which may belong to silico-titanates or be present as rutile. The silica is more than enough to have formed sanidine instead of leucite if the conditions had been favorable.

It is plain that a rock containing leucite, with diopside and phlogopite of the ascertained composition and in the observed proportions, cannot have so high an amount of silica without containing an excess of the acid radical unless some very acid silicate is present. The only possible explanation of the ascertained chemical composition, without assuming free silica, is in supposing that the apparent leucite is a regular mineral of higher silica contents than leucite, with the ratio of alumina

to potash the same. By the calculation of the Boar's Tusk rock it would seem necessary to assume that the hypothetical mineral had the composition of orthoclase. No such mineral being known, this hypothesis would quickly lose all suggestion of support were it not for the results derived from a calculation of the analysis IV.

CALCULATION OF ANALYSIS IV.

| Molec. ratio. | Apatite. | Diopside. | Phlogopite. | Leucite. | Residue. |
|--|----------|-----------|-------------|----------|----------|
| SiO ₂ ----- 895 | | 76 | 144 | 348 | 327 |
| TiO ₂ ----- 24 | | 2 | 6 | | 16 |
| Al ₂ O ₃ ----- 109 | | | 22 | 87 | 0 |
| Fe ₂ O ₃ ----- 20 | | | 3 | | 17 |
| FeO ----- 17 | | 2 | 3 | | 12 |
| CaO ----- 71 | 39 | 37 | | | 0 |
| MgO ----- 161 | | 39 | 122 | | 0 |
| K ₂ O ----- 119 | | | 25 | 87 | 7 |
| Na ₂ O ----- 27 | | | | | 27 |
| P ₂ O ₅ ----- 12 | 12 | | | | 0 |
| | | 10.7 % | 22.3 % | 35.7 % | |

The calculation shows a marked excess of the alkalis and a very large one of silica. In this case the sulphuric acid is so low as to be of little effect upon the calculation in assuming it to represent noselite. Here, then, as before, there is an apparent excess of silica which cannot be discovered in the rock in the form of opal, tridymite, or quartz, and the excess of alkali is equally difficult of explanation. Alumina cannot be assumed as too low by error of analysis, as the analyses are quite consistent in this respect and repeated determinations have yielded almost identical results, as also in the case of SO₃.

Acting upon the suggestion that the apparent leucite of these rocks might possibly have a different composition from the normal, Dr. Hillebrand treated the powder of the wyomingite yielding the result under IV with dilute nitric acid (1 acid to 40 water) and found in solution the following:

| | Molec. ratio. |
|--------------------------------------|---------------|
| SiO ₂ ----- | 6.08 |
| TiO ₂ ----- | 101 |
| Al ₂ O ₃ ----- | 3 |
| Al ₂ O ₃ ----- | .91 |
| FeO* ----- | 9 |
| FeO* ----- | .50 |
| CaO ----- | 2.13 |
| SrO ----- | 38 |
| SrO ----- | .10 |
| BaO ----- | .14 |
| MgO ----- | 1.51 |
| MgO ----- | 38 |
| K ₂ O ----- | 1.21 |
| K ₂ O ----- | 13 |
| Na ₂ O ----- | .28 |
| Na ₂ O ----- | 4 |
| P ₂ O ₅ ----- | 1.54 |
| P ₂ O ₅ ----- | 11 |
| | 14.61 |

* All iron as FeO.

The CaO is almost exactly what is required for P_2O_5 in apatite, hence the soluble magnesian silicate must be phlogopite. But if the requisite amount of alumina be taken to form phlogopite on the basis of the magnesia, there remains but a trace of alumina to combine with the residue of the alkalis in leucite or any other mineral; and even if leucite should first be calculated out, assuming all the alumina to be in that mineral, there would remain a considerable residue of the alkalis. Silica is here, too, in excess of the requirements to form any known rock-making silicate with the bases in solution.

While a calculation of the analyses of orendite is impossible without knowing the composition of the peculiar amphibole, yet the difficulty of accounting for the alkalis found is even greater than in the wyomingite, because both analyses show less alumina and more alkali than before. The relation of alumina to alkali is much less than 1:1, whereas in all the important alkali-bearing silicates of rocks that ratio holds good.

A comparison of analysis VII with the preceding ones shows that the madupite is even more closely related to the type of the Leucite Hills than might be suspected from the similar developments of the pyroxene and mica in the two cases. This similarity alone led Kemp to correctly characterize the Pilot Butte type as "clearly a variant from the group of rocks of the Leucite Hills." In the presence of the rarer elements, Ce_2O_3 , Di_2O_3 , Cr_2O_3 , SrO, BaO, SO_3 , Fl, Cl, and in the ratio between potash and soda this magma certainly shows blood relationship—consanguinity—with the magmas of the Leucite Hills.

CALCULATION OF ANALYSIS VII.

| Molec. ratio. | | Perovskite and Apatite. | Diopside. | Phlogopite. | Noselite. | Leucite. | Residue. |
|----------------|------|-------------------------------|-----------|-------------|-----------|----------|----------|
| SiO_2 ---- | 711 | | 346 | 120 | 42 | 203 | 0 |
| TiO_2 ---- | 21 | 21 | | | | | 0 |
| Al_2O_3 ---- | 90 | | | 17 | 21 | 52 | 0 |
| Fe_2O_3 ---- | 32 | | 2 | 2 | | | 28 |
| FeO ---- | 17 | | 10 | 2 | | | 5 |
| CaO ---- | 221 | 58 | 163 | | | | 0 |
| MgO ---- | 272 | | 173 | 99 | | | 0 |
| K_2O ---- | 85 | | | 20 | 14 | 51 | 0 |
| Na_2O ---- | 14 | | | | 14 | | 0 |
| P_2O_5 ---- | 11 | 11 | | | | | 0 |
| SO_3 ---- | 7 | | | | 7 | | 0 |
| Fl ---- | 25 | | | 25 | | | 0 |
| | 1506 | 90 | 694 | 285 | 98 | 306 | 33 |

From the character of the minerals developed in the madupite and the knowledge of their composition obtained through the analyses of the diopside and phlogopite, one may calculate

very closely the composition of the glassy base. Assuming that the lime remaining after deductions for apatite and perovskite is a measure of the diopside of the rock, and that the magnesia surplus after the formation of diopside is all contained in phlogopite, of the composition found in the analyses already given, there remains, after calculating out apatite, perovskite, diopside, and phlogopite, a residue of silica, alumina, potash, and soda which is almost exactly that necessary for leucite and noselite, calculating the latter from the sulphuric acid, as in the case of the Boar's Tusk wyomingite.

The result of these calculations is to indicate that if this magma had entirely crystallized, it must have had very nearly the following percentage development of the named constituents:

| | | |
|-------------------|-------|--------|
| Diopside | 46.1 | } 65.0 |
| Phlogopite | 18.9 | |
| Leucite | 20.3 | } 26.8 |
| Noselite | 6.5 | |
| Accessories | 8.2 | |
| | 100.0 | |

The amounts of phlogopite calculated from the fluorine contents of the rock and from the magnesia after deducting for diopside agree very closely. While I have been unable to detect a single grain of leucite or noselite in my sections, Kemp refers to a few very minute particles of leucite seen by him. In the calculations I have disregarded the amounts of strontia and baryta in the absence of a good basis for assigning them, although it is known that a part of the baryta is in the phlogopite.

By comparing the analysis of madupite with that of missourite, the granular augite-leucite rock recently described by Weed and Pirsson,* reproduced under XI of the table above, a marked similarity may be discovered. Missourite is richer in magnesia and poorer in lime than madupite, and it has 15 per cent of olivine with only 6 of biotite. As is well known, the quantitative relations of olivine, biotite, and leucite are quite variable in very similar rocks, and under slightly different conditions the missourite magma might have yielded more mica and less olivine and leucite. Each rock has about 50 per cent of augite or diopside, and while missourite has 37 per cent of olivine, leucite, and biotite, the crystalline madupite would have had 39 per cent of leucite and phlogopite. It is quite possible that the deep-seated granular equivalent of madupite is a near relative of missourite.

*Missourite, a new leucite rock from the Highwood Mountains of Montana. This Journal, (4), vol. ii, 1896, p. 315.

Classification and Nomenclature.

In the foregoing pages new names have been proposed for three rock types described. It is now desired to explain as clearly as possible the grounds for adding three new names to the rapidly growing list of rock varieties, and this involves more or less discussion as to principles of classification.

With regard to the present tendency to confer names upon many more or less distinct, newly recognized or more narrowly defined, rock types, it must be admitted that from several sources the protests against this course are most natural. Teachers, geologists with whom petrography is a side issue, and those to whom all rocks are merely accidental mixtures of various minerals,—to all these the new terms are abhorrent. But while a period of confusion is to be regretted, it appears to me that the recognition and naming of every truly distinct rock type may be a necessary prelude to the much needed reform of our present illogical and inadequate petrographical scheme.

Igneous magmas must be classified on chemical grounds; their crystalline equivalents principally upon mineralogical constitution, as the more or less evident expression of chemical composition and as the cause of the principal characteristics of rocks. It does not follow, as is sometimes asserted, that because rock-making minerals may be developed in infinitely varying proportions, that there are no natural rock types or groups. There is, for each prominent rock constituent, a considerable range in its development within which it places its own stamp upon the rock containing it. It may play the leading role, or share the honors equally with others, or be subordinate. With a given structure the habit of the rock depends largely upon the minerals which are its leading constituents. Most new rock names of the last few years have been conferred, consciously or unconsciously, in recognition of this natural law. But this law has not yet been fully recognized in the system of petrography, and until it is so recognized the system will be unsatisfactory. The character-giving relative abundance of minerals in rocks is not awarded proper weight in classification.

The weakness of the present scheme in the direction alluded to lies in giving to the feldspars and feldspathoids far too much weight, and to the dark silicates far too little, in constructing the frame work. "Rocks with feldspar,"—"Rocks without feldspar,"—these two divisions comprise all igneous rocks. Gabbro is mineralogically a rock composed of basic plagioclase and pyroxene, and within it are included everything from anorthosite to the vanishing point of the feldspar, and we are

even told by Rosenbusch that peridotite and pyroxenite are annexes of the gabbros.*

The fact that the names leucitite and nephelinite are currently applied to rocks in which leucite and nepheline are not necessarily of much quantitative importance, also illustrates very well the inadequate and illogical character of our present petrographical nomenclature. The natural application of these terms would be to rocks so rich in leucite or nepheline as to derive their dominant mineralogical features from the characteristics of these species. But as a fact one must search very carefully with a microscope to detect any leucite in some of the so-called leucitites.

The leucite rock described by Zirkel, to which it is here proposed to give the name *wyomingite*, has been placed in the group of the leucitites by both Zirkel and Rosenbusch in their latest systematic works, but with comments upon its exceptional character, removing it far from its nearest ally in the group. The new name is proposed for this rock in recognition of its peculiar character, and also as a part of a scheme for reclassifying the leucite rocks which it is hoped may find favor with those who have to deal with this interesting class of igneous rocks.

As a first step, in spite of established usage, I should be glad to see the term leucitite reserved for the rock that has not yet been discovered, to my knowledge, consisting essentially of leucite, with all other minerals of subordinate importance. There is good reason to believe that such rocks are possible and will be found at no distant day. The same suggestion is made for nephelinite, on the same grounds.

Following leucite would come the rock here called *wyomingite*, and its granular equivalent, in which leucite and its allies are of approximately equal importance with the ferromagnesian-lime silicates, and then a rock of which madupite is deemed a vitrophyric representative. Leucite-sanidine, leucite-nepheline and leucite-plagioclase rocks are known, or will be found, in which these elements preponderate, and they are certainly very different from the types from which the present nomenclature of leucite rocks has been mainly derived, where leucite is of secondary importance.

Reviewing the chemical and mineralogical characteristics of the rocks under discussion, it is evident that they are notable for their high contents in the alkalis, and especially for the strong preponderance of potash over soda; and although *wyomingite* is one of the richest known rocks in leucite, it is not this fact alone which gives character to it. Prominence must be given to the fact, which is also true of the sanidine-bearing orendite and of the madupite with its glassy base, that

* *Massige Gesteine*, 3d ed., pp. 344, 367.

the preponderance of potash has controlled the character of the ferromagnesian-lime silicates. Such rocks must be contrasted with the tinguaïtes, derived from magmas rich in soda, producing nepheline and alkali-feldspar, with pyroxenes or amphiboles of characteristics due to the entrance of soda and ferric oxide into the molecules.

The three rocks described belong to a series whose magmas were relatively so rich in potash that soda has not played any perceptible role in the products of crystallization. It has been prevented from combining with lime in plagioclase or with ferric oxide in the ægirine molecule. If it does, in certain rocks, go with sulphuric acid into noselite, it still fails to make itself noticeable.

Wyomingite is essentially composed of leucite, a magnesia-potash mica, and diopside, all in large quantities. Its magma was characterized, as has been pointed out, by richness in potash with low alumina and considerable amounts of magnesia and lime. Should it be demonstrated by future experience that other leucite rocks actually contain more than enough silica to have made sanidine in place of all the leucite, it may be desirable to restrict the type to such acid leucite rocks; but it seems to me at present better to disregard this excess, in definition, as quite anomalous, for the rock does not derive any observable physical characteristic from the superabundant silica.

The structure of this original *wyomingite* is rudely fluidal and porphyritic, but nevertheless of an intermediate, more or less confused character, best expressed, among existing terms, as hypidiomorphic. Geological occurrence is omitted from these definitions because it has to my mind no legitimate place in the purely petrographical classification of igneous rocks. The rock is known in surface masses and in a volcanic conduit near the surface. It is probable that the structure observed may extend to considerable depths. Its granular equivalent should receive another name.

Orendite was derived from the same magma as the *wyomingite*. It has sanidine and leucite in about equal quantities, with magnesia-potash mica and diopside as the other essential constituents. The development of a peculiar amphibole in the type of the Leucite Hills can only be regarded as a local characteristic. *Orendite* has in this present case a still greater complexity in structure than the *wyomingite*, but much of it must be considered as of local importance only. According to the nomenclature of Zirkel, the rock would be classed with the leucite-trachytes, and by that of Rosenbusch as leucite-phonolite. While agreeing with Dr. H. S. Washington* in his criticism of the term leucite-phonolite, I think that the same

* Italian Petrological Studies, I; Journal of Geology, vol. iv, 1896, p. 555.

objection applies with somewhat lessened force to the other name. If a nepheline-sanidine rock is to be called phonolite, an independent name is also appropriate and desirable for analogous leucite-sanidine rocks. As Washington remarks, a leucite-phonolite should be a leucite-nepheline-sanidine rock. And it seems to me that compound names of this character should always be used for the mineralogical varieties of a given species.

Madupite may be defined as consisting essentially of diopside and a magnesia-potash mica with leucite in decidedly subordinate amount. Its magma was low in silica, alumina and iron, rich in potash, and contained so much lime and magnesia that silicates of these bases are the principal constituents, yet controlled in their development by the strong potash element. The calculation of the analysis of madupite from Pilot Butte shows so clearly what must have been the products of its crystallization that this rock may be considered the vitrophyric equivalent of the type so defined.

As to the systematic relationships of these rocks, there is not very much to be said beyond what has already been presented in discussing their relationship to each other. No other rocks known to me approach very near to the types described. As leucitic rocks their nearest allies are some of the Italian "leucite-trachytes," in which, however, soda plays a more important role. As pyroxene-mica rocks the relation to the minettes and vogesites is most striking. In fact I think that the rocks may be effectively characterized as surface equivalents of lamprophyres containing leucite instead of feldspar, rich in potash, lime and magnesia, and poor in alumina and iron. It is to be noted that leucite-bearing camptonites and tinguaites are now known.

It is not possible to say with certainty what mineralogical composition the deep-seated portions of these magmas may have. As the recent investigations of Doelter* have clearly shown, the influence of physical conditions and of accompanying mineralizing agents, such as fluorine, is very great in just such magmas as those of the rocks under discussion. The Leucite Hills magma has very possibly yielded a sanidine rock in depth, yet the Boar's Tusk conduit, where exposed, is occupied by a leucite rock. It is difficult to see how the madupite magma, consolidated in the lower parts of its eruptive channel, can fail to contain much leucite, and if only that portion of the geological body were known, there can be little doubt that the rock would be called a lamprophyre by the German school of petrographers. If coarsely granular, it might be nearly related to missourite, as already pointed out.

*C. Doelter: Synthentische Studien; Neues Jahrbuch für mineralogie, etc. 1897, Bd. i., p. 1.

Of course to call these surface rocks lamprophyres is to disregard the fundamental conception of Rosenbusch as to the geological significance of this group of "dike-rocks." But I fully agree with Iddings,* who has discussed this question at some length, that the lamprophyres are abundantly represented at the surface by lavas differing in structure and mineralogical composition from the dike rocks, as a result of differing conditions of consolidation. The Boar's Tusk wyomingite has, moreover, a decided resemblance to minette in habit, making due allowance for the different roles played by leucite and sanidine as a result of contrasting crystal forms.

It is with great regret that I confess my inability to state the existing relationship in occurrence between wyomingite and orendite. The former is massive, the latter always vesicular, and I believe them to be merely different parts of one flow. The punice contains neither leucite nor sanidine.

Inclusions in the Leucite Hills Rocks.

There are many inclusions of foreign rocks in the lavas of the Leucite Hills and in the Boar's Tusk. These were also noted by Kemp, who found them especially abundant in the southwestern part of the principal mesa, and who mentions sandstone as the most common type. The fragments occur in all parts of the Hills visited by my party, and many different rocks were observed: sandstone, limestone, oolite, granite, and some peculiar mineral combinations to be mentioned.

The most noteworthy feature of these included fragments is the very distinct caustic action of the lava displayed in most cases. Some quartzose sandstone inclusions are vitrified in considerable part, and certain granitic rocks have also suffered partial fusion. It is noticeable that a rounded form is common among these inclusions, but there is little or no evidence that this rounding is the result of fusion.

Rocks composed of pyroxene and plagioclase feldspar seem quite abundant, and some were found consisting almost wholly of plagioclase rich in lime. Still others are basic combinations of augite and biotite with but little feldspathic material.

The action of the magma upon these inclusions may be illustrated from a few instances. One small inclusion of rounded form appears megascopically to be a medium-grained rock of green pyroxene and feldspar, but it is noticeable that the feldspar grains are not distinct and cleavage can not be distinctly made out. Microscopical examination shows the feldspar to have been plagioclase, but it has been acted upon by the magma and partially destroyed. Along cleavage lines and on

* The Origin of Igneous Rocks, Bull. Phil. Soc., Washington, vol. xii, pp. 172-178, 1892.

the planes of albitic twinning the feldspar is in part replaced by cloudy isotropic matter leaving remnants of feldspar with somewhat weakened double refraction here and there. In some parts where no optical action can be discerned, the former twinning planes may be traced by the varying cloudiness. On the contact with the orendite containing this inclusion, the cloudy mass gives way to a clear glass. In it are apparently colorless rounded or irregular granules which seem to be diopside, though not developed in determinable form. The contact between inclusions and rock is sharp and no change in the character of the latter can be made out which might be referred to assimilation of the fused inclusion.

Augite is much less attacked than feldspar; it is often entirely unaltered in contact with the cloudy product from the feldspar. In some places the diopside grains have a rim of apparent resorption origin, comparable with those so common about hornblende. This zone has a granular appearance and is usually not resolvable into distinct mineral constituents, but where the grain affected is in contact with the surrounding rock reddish-brown mica, magnetite, and a predominant pale green pyroxene seem to be the resulting minerals.

In the rock of Orenda Butte numerous pebble-like inclusions were found which belonged principally to two types, one consisting almost entirely of labradorite with a few specks of ferromagnesian minerals, and the other a granular mixture of quartz and alkali feldspar. In the former a cloudy alteration of the plagioclase penetrating between the grains and on cleavage planes is like that already described.

The quartz-alkali feldspar rock shows much greater alteration. Megascopically these inclusions are seen to be very irregularly porous, the feldspar dull and the quartz grains much cracked. Under the microscope the feldspar presents various intermediate stages of alteration from the normal mineral to a glass. The progress of alteration is marked by the appearance of a cloud of minute dark bodies along basal and pinacoidal cleavage planes and on chance fractures. These seen under high powers to be gas pores and to be connected by irregular arms where most numerous. The optical action of the feldspathic substance is often distinguishable but much weakened. A peculiarity observed in one of the inclusions seems worthy of notice. It is the development of the apparent gas pores on curving concentric planes comparable only to those of typical perlite. This phenomenon is most distinct and takes place in feldspar substance still showing optical action though weaker than normal. Isotropic arms representing complete fusion penetrate many grains following the cleavage and other fissures marked by the cloudy parts. The recrystallization of the melted parts has yielded a fine, irregular spherulitic growth in some places.

ART. XVII.—*Stylolites* ; by T. C. HOPKINS.

STYLOLITES, "Crow-feet" or "toe-nails" as they have been called by the quarrymen, form a very conspicuous feature in the oölitic limestone quarries in Indiana. As they seriously injure a great quantity of otherwise handsome building stone, they have a peculiar interest to the quarryman. The writer, in his recent investigations for an economic report on this limestone, was early impressed with the commercial importance and scientific interest of the stylolitic seams. An examination of the accessible literature on the subject failed to reveal a satisfactory explanation.* The only commonly accepted theory in the English literature is that given by Marsh and accepted by both Dana and Geikie in their text-books, i. e. that they are caused by the slipping through vertical pressure of a part capped by a fossil shell against an adjoining part not so capped.

However applicable this theory may be in other localities, it appears to be untenable in the Indiana oölitic limestone region because (1) a very small percentage, probably less than one per cent, of the stylolites are capped with fossils; (2) many of those that are capped with shells have a fragile gastropod shell that shows no evidence of distortion or pressure in any way; (3) in many places where the stylolites are a pronounced feature of the rock, there are shells in abundance a few inches or a few feet above and below the stylolites, but none at or near them; (4) in many places the stylolites show just the opposite to pressure, occurring along an open bedding seam.

Other theories which appear to be discarded now are shown in some of the old names, such as *lignilites*, from their resemblance to wood, possibly thought to be fossilized wood. Crystallites presupposes them to be caused by crystallization, and the term *Epsomites* that the crystals were Epsom salts. Other names by which they have been known are *suture joints* and the quarrymen's terms *crow-feet* and *toe-nails*. They frequently prefix a harsh adjective to these terms.

Before offering an explanation for their origin a brief description is here given, as they no doubt differ in some particulars from stylolites elsewhere. They occur along nearly horizontal seams and appear in the quarry face very much as a suture joint, running nearly horizontal. Projecting both down and up from the general direction of this seam are numerous tooth-like projections which vary in length from a fraction of an inch to five or six inches. The projections are sometimes

* The views of different German writers mentioned later were not known to the writer until after the formation of his own theory.

pointed and sometimes straight. The sides are generally roughly striated but not slickensided. The line of the seam is nearly always black or very dark-colored. There is frequently a thin layer of clayey material and rarely a little iron pyrites in the seam. The rock immediately adjoining the seam is frequently blue in color even when the surrounding rock is buff.

It is the opinion of the writer that the stylolite seams are bedding seams because (1) they correspond with the grain or bedding of the rock, occasionally running on the false bedding but never across the grain; (2) they are in places traceable with no break or sharp line of division into the common bedding planes having no evidence of stylolites; (3) there is in nearly every instance a layer of carbonaceous material, sometimes a mere film, sometimes nearly half an inch thick; (4) they are always of considerable though not unlimited extent; (5) a view from above, shown in a few places on quarry floors, shows water action not unlike the common bedding plane; (6) they frequently occur between the oölitic stone and the underlying Harrodsburg limestone or the overlying Mitchell limestone, beds which are not at all oölitic; (7) the cross bedding always terminates at the stylolite seam; in no instance was it observed to cross it.

The explanation of the stylolitic or tooth-like markings along this seam is not so satisfactory as is the evidence of its being a bedding seam. It is quite probable that they have been caused by different agencies. Some may be mud cracks, some may be due to the action of rain or spray on the exposed surface and some may be caused by the escape of gases from the limestone mud. Other agencies may have been active, but the first two mentioned above appear to the writer to be the more probable.

The following theories proposed by different German writers are many of them suggestive, but do not appear to have met with any favor by the English writers, if indeed they have been consulted. Plieninger* thought that the cracks or crevices originating at the surface by the drying mud were the cause, and that the pillar-like or columnar forms could be produced by rain.

Von Cotta and Rossmassler† put them in the same class with the "ice needles" produced on the surface of the soil in winter.

Fallati and Quenstedt have likened the stylolites to glacial pyramids of ice left on the surface of the glacier, or little pyramids of earth which owe their columnar structure to a

* Württemberg Naturwiss. Jahreshäfte, 1858, vol. xiv, p. 292.

† Zirkel, Lehrbuch der Petrographie, 2d ed., vol. i, p. 535.

small stone or shell protecting the material underneath, while that surrounding is washed away by the rain in the case of the earth and by the sun on the ice.

Weiss,* corroborating the above, states that in his observations in a Bundsandstein formation, that a foreign body like a mussel shell or a piece of clay forms a protective covering to the drying lime particles, whereby the drizzling water has modeled out the stylolite by carrying away the material between the protected parts.

Zelger,† after detailed work on the stylolites, announces that they are formed by the escape of compressed gases through the soft plastic mass and the later filling of the passage-ways.

Gümbel states that the stylolites, particularly those from Rudersdorf, carry on top a clay cap which without doubt has come from a clay or marl layer which marks the lower limits of the bed of stone bearing the stylolites, and which is a part of the underclay layer ascending with the stylolite mass.

Zirkel‡ says that the stylolites remind one of the phenomenon called creeps by the English miners, in the swelling up and pressing in of the underclay of the coal into the galleries or openings made in the working until the gallery is filled by the underlying clay.

Quenstedt states§ that they are due to the filling in of hollow spaces made in the rock while yet soft by the movements of mussel shells. His later view was that where two beds overlie one another, separated by shells and a layer of clay or marl, the two beds having a different hardness, the pressure of the overlying mass would tear the clay bed and the underlying and overlying beds would be pressed into one another, thus causing the stylolites.

It will thus be seen that the German writers nearly all agree in thinking that the stylolites are bedding planes but do not agree in the origin of the tooth-like markings. As there is a difference in the appearance of the stylolitic points at different localities so they may be caused by different agencies. Some of them are evidently mud cracks caused either by the sun (Plieninger) or by the frost (Von Cotta). Some are apparently caused by the action of the rain or spray on the limestone mud (Fallati, Quenstedt, Weiss); but some may in part be caused by organisms of some sort (Quenstedt) or by the escape of gases (Zelger) from the plastic mud.

The cone-in-cone structure closely allied in some respects to the stylolites was not observed anywhere in the oolitic limestone district.

* N. Jahrb. f. Min., 1868, p. 729.

† Ibid., 1870, p. 833.

‡ Lehrbuch der Petrographie, vol. i, p. 536.

§ N. Jahrb. f. Min., 1837, p. 496, and Württemberg Naturwiss. Jahreshfte, 1853, ix, p. 71, and Epochen der Natur, 1860, p. 200.

ART. XVIII.—*On the Extinct Felidæ*; by GEO. I. ADAMS.

SINCE publishing my studies on the Extinct Felidæ of North America* I have had the opportunity of seeing many of the European and Indian specimens, and I now wish to publish some further corrections in the synonymy of the group and emphasize the distinctions which exist among certain genera. I am indebted to Dr. Gaudry of the *Jardin des Plantes* and to Dr. Woodward of the British Museum for privileges of study.

Structure of the Canines of the Felidæ.

The structure of the canines of the Machærodonts with their posterior and anterior denticulate borders is well known, but some errors have arisen from the failure to recognize that the same elements are present in the canines of all the Felidæ. An examination of the unworn canines of the lion, for example, will show that there are two roughened ridges on the interior face of the tooth which correspond to the denticulate lines found in *Machærodus*. In *Pseudælorus* the canines have a structure intermediate between those of *Felis* and *Machærodus*. They are described as being rounded anteriorly and having the posterior border sharp and denticulate. The anterior denticulate ridge is however present, but is situated on the inner face of the tooth except near the point where it forms the anterior border. The accompanying outlines and cross-sections will give an idea of the structure found in each.

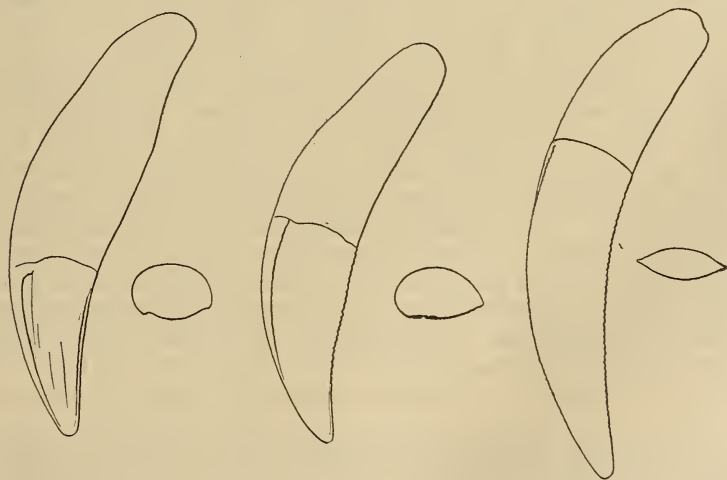
FIG. 1. *Felis leo* $\times \frac{1}{2}$.FIG. 2. *Pseudælorus* $\times \frac{1}{2}$.FIG. 3. *Machærodus* $\times \frac{1}{2}$.

* This Journal, June, 1896.

In all cases where the teeth are well preserved and unworn these roughened ridges or denticulate borders are present. The canines of *Ælurogale* are rounded anteriorly and have a sharp posterior border which is denticulate. The anterior denticulate line is located on the inner face as in *Pseudælorurus*. The somewhat peculiar canines of *Nimravus* which are described as pike-shaped are after all not so anomalous. The posterior border, as was noted in the original description, is denticulate and the anterior face is rounded, a sharp ridge separating it from the inner. The canines of *Archælorurus* are described as without anterior or posterior denticulate ridges, but as I have previously stated these are not well preserved. It is not probable however that they differed from all other known specimens of the Felidæ. While the canines of *Nimravus* are exceptionally straight they are not so peculiar as the illustration would suggest.

• GENUS *Nimravus* Cope.

(Synonyms, *Archælorurus* Cope, *Ælurogale* Filhol, *Ailurictis* Trouessart.)

The structure of the molar series in *Nimravus*, *Archælorurus* and *Ælurogale* is the same, and now that the canines are shown to possess no essential differences I propose to combine them in one genus. *Ælurogale* has been shown by Trouessart* to be occupied, hence *Nimravus* would have the priority. The genus as thus constituted would be defined as follows:

Dentition Pm $\frac{4-3}{4-2}$ M $\frac{1}{2-1}$. Superior canines rounded

anteriorly, posterior border sharp and denticulate, the anterior denticulate ridge situated on the inner face of the tooth at its base but forming the anterior border near its point. Superior sectorial without anterior cusp, no positive inner cusp present, the inner root supporting instead a convex buttress which descends from the principal cusp. Lower sectorial with heel but no postero-internal cusp. Anterior portion of the mandible with an obtuse angle separating the anterior face from the inferior. The variation in dental formula is quite remarkable, but Filhol has already noted as great a variation for *Ælurogale*. The dentition of *Nimravus gomphodus* is Pm $\frac{3}{2}$ M $\frac{1}{2}$, but in a second specimen the small tubercular molar is absent from one side. The dentition of *Archælorurus* is Pm $\frac{4}{3}$ M $\frac{1}{2}$, that of the type specimen of *Ælurogale*, Pm $\frac{3}{3}$ M $\frac{1}{2}$. The genus also shows a considerable variation in size and one com-

* Catalogue des carnivores vivants et fossiles 1886. "Le nom d'*Ailurogale* ayant été employé précédemment par Fitzinger, pour un sous-genre des chats actuels (type *Felis planiceps*) nous avons proposé de changer le nom du présent genre en *Ailurictis*."

parable with that of the *Hoplophoneus* and *Dinictis* series. The genus is represented in both North America and Europe and it is probable from a jaw fragment described by Lydekker as *Æturogale sivalensis* that the geographical range extended to India.*

GENUS *Machærodus*.

I wish to add some notes from my observations of the type skulls of *M. meganteron* and *M. palmideus*. *Machærodus* differs from *Hoplophoneus* in having basal cusps on the premolars and a small second anterior cusp on the superior sectorial. In regard to this last point I was in error in my previous definition of the genus. The cusp being very small I failed to recognize it in the illustrations, mistaking it for the cingulum. The alisphenoid canal is present just as in *Hoplophoneus* and the post-tympanic and post-glenoid processes are well separated. The close resemblance between the two genera in other respects than those of dentition makes it very probable that *Hoplophoneus* is the direct ancestor of *Machærodus*.

GENUS *Smilodon* (Syn. *Dinobastis* Cope).

There is a tendency among European palæontologists to disregard this genus, including it in *Machærodus*. This is probably in part due to the fragmentary condition of European specimens which often makes certain characteristics indeterminate. The genus *Smilodon* differs from *Machærodus* as regards dental characters as follows. The second anterior cusp on the superior sectorial, which is incipient in *Machærodus*, is well developed in *Smilodon*, and the basal cusps on the premolars are much larger. The incisors have basal cusps, while in *Machærodus* there is only a suggestion of this element. There are perhaps no new structural elements nor have any been lost, but there are developmental differences. In the skull however there are decided structural differences, namely, the absence of the alisphenoid canal and the coössification of the post-glenoid and post-tympanic processes below the auditory meatus. The teeth being the parts most often preserved, these points are unfortunately indeterminate in some well known specimens, but that should not be an excuse for overlooking their value. Lydekker has figured the posterior portion of a skull of *M. sivalensis*† Falc. and Caut., showing the coössifi-

* Pal. Indica, Series X, vol. ii, p. 317.

† The indistinct figure of the superior sectorial of this species, so often repeated along with the statement that it possesses an internal cusp, has caused some confusion. Bose has previously stated that it has none. An examination of the specimen shows that there is an internal buttress as is commonly found in the genus, but no cusp.

cation of the post-glenoid and post-tympanic processes and has called attention to its resemblance to American Smilodons but did not refer it to that genus. *M. palæindicus* Bose will also probably prove to be a *Smilodon*.

The specimen from Pikerimi, in the Munich museum, described by Wagner as *F. leoninus* and now referred to *M. cultrideus*, is very like *Smilodon*, but only the anterior portion of the skull is preserved. *M. latidens* was described by Owen from a canine and an incisor having basal cusps. Gervais has since referred other material to this species. *Dinobastis* Cope, in which the generic character is the absence of the internal root of the superior sectorial, is known only from teeth and a few foot bones. The incisors, as Cope has noted, have basal cusps. There are strong resemblances between this specimen and the material now referred to *M. latidens*. There is some hesitancy in accepting a genus founded upon such limited material, especially when the differences are so slight. *Dinobastis* can very reasonably be considered a synonym of *Smilodon*. Finally the genus *Smilodon* is not only a later developmental form but is found in later deposits, and this is not an unimportant argument in favor of retaining it as a distinct genus.

EXPLANATION OF FIGURES 4 TO 8.

All figures $\times \frac{1}{2}$.

FIGURE 4.—*Nimravus gomphodus* Cope, after Cope.

FIGURE 5.—*Nimravus confertus* Cope, after Cope.

FIGURE 6.—*Nimravus debilis* (*Archelurus debilis* Cope), after Cope.

FIGURE 7.—*Nimravus intermedius* (*Ælurogale intermedius* Filhol), after Filhol.

FIGURE 8.—*Nimravus minor* (*Ælurogale intermedius*, var. *minor*, Filhol), after Filhol.

Lawrence, Kansas.

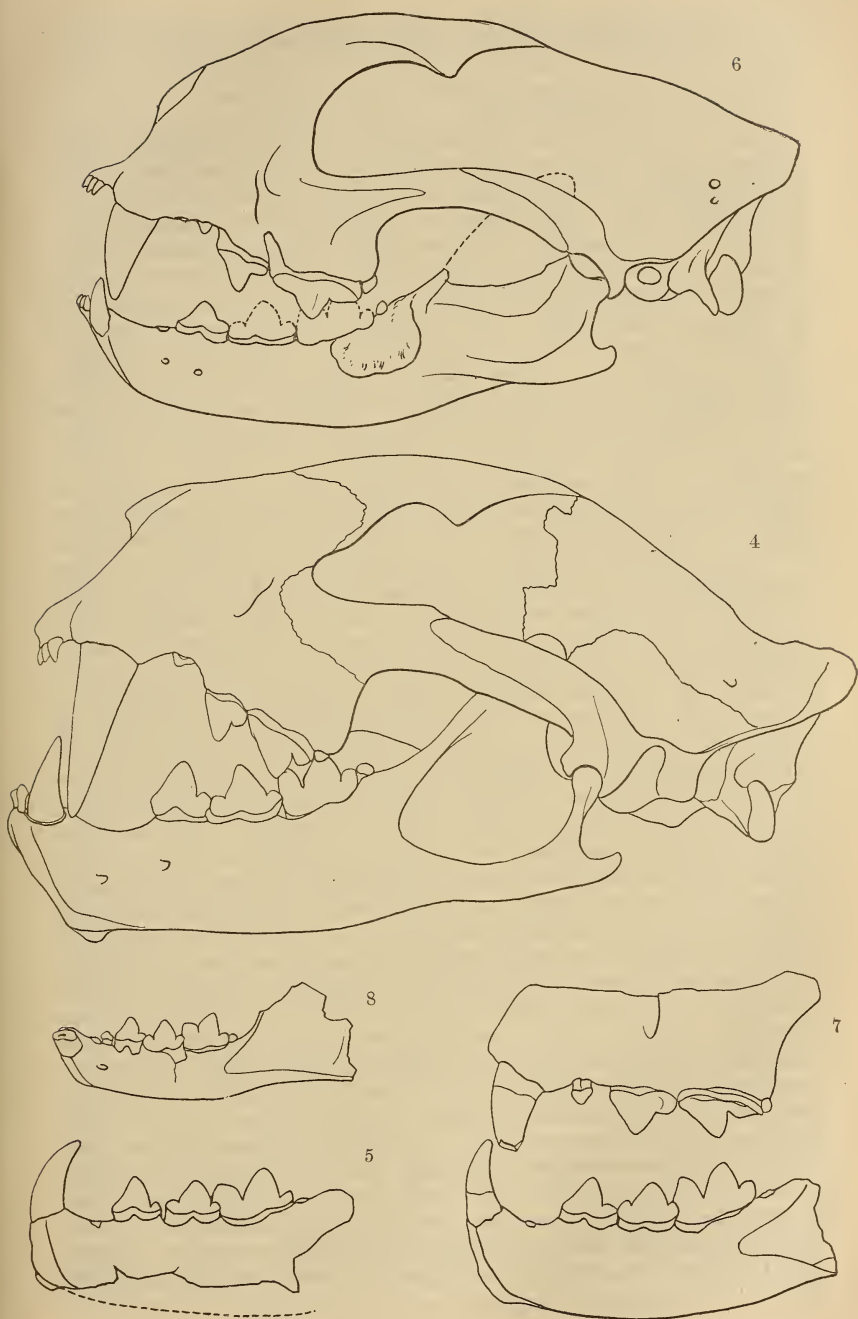

Nimravus series $\times \frac{1}{2}$.

SCIENTIFIC INTELLIGENCE

I. CHEMISTRY AND PHYSICS.

1. *On the Electrical Convection of certain Dissolved Substances.*—In their investigations upon solution and pseudo-solution, PICTON and LINDER have studied the nature of the electric transmission which takes place by means of certain dissolved substances. In the case of arsenous sulphide, for example, the conductivity of its solution is extremely low, the current passing being in one case only $7 \cdot 10^{-6}$ ampere; and even this may be due to traces of the oxide. The passage of this small amount of current, however, is accompanied by the repulsion of the colloidal sulphide as a whole from the negative electrode. Using other substances, it appeared that in colloidal solutions which are too coarse-grained to pass through a porous pot and which show a coarse-grained structure by the optical test,* such as arsenous sulphide (γ), ferric hydrate and silicic acid, it is impossible to repel the dissolved substance vertically upwards as completely as downwards; a result due presumably to the action of gravity on the large colloidal particles. If, however, high grade solutions be employed, such as iodine, aniline blue and magdala red, which are readily filterable and which do not contain particles large enough to scatter light, then the substances can be repelled completely from the lower electrode, provided the solution is not too strong. In the case of aniline blue, however, the repulsion is complete even with 2 or 3 per cent solutions. If the solvent be highly non-conducting, as carbon disulphide for example, then no repulsion is observed. Thus while iodine in an imperfectly conducting medium was repelled from the negative electrode, an electromotive pressure even of 210 volts failed to show repulsion when the iodine was dissolved in carbon disulphide. The rapidity of the repulsive action seems to vary with the current strength; while its direction depends on the chemical character of the dissolved substance. Thus ferric hydrate, which is basic, is repelled from the positive electrode; while iodine and arsenous sulphide, which are acidic, are repelled from the negative electrode. In the case of the dyes mentioned, the result is not so simple; aniline blue, for example, being repelled from the negative electrode whether as disodium salt or as sulphonic acid. Hence hydrolysis seems to take place, which in this case would give in solution sodium hydroxide and sulphonic acid; so that the repulsion is due to the latter product. A table is given showing the results of an examination of a large number of substances in this way. On mixing acidic and basic dyes, the aggregates form lower grade solutions and are carried as a whole by the convection. By adding alcohol, however, dissociation appears to occur and the dyes are repelled in opposite directions. The authors

* See this Journal, III, xlix, 467, June, 1895.

call attention to this remarkable mimicry of ionic dissociation. Are these slowly moving molecules conveying two currents in a way at all analogous to conduction by ions? Curiously enough, in some of these separations a banded structure has been observed, recalling the phenomenon of stratification in gases.—*J. Chem. Soc.*, lxxi, 568–573, May, 1897.

G. F. B.

2. *On the Phenomena of Supersaturation and Supercooling.*—The phenomena attending the solidification of supersaturated solutions and of supercooled liquids have been studied by OSTWALD. By suitably selecting the substances used, he has avoided the influence of dust particles; and he then finds that solidification is brought about only by the introduction either of a crystal of the same substance or of one strictly isomorphous with it. Thus fused salol, melting at 39.5° , cannot be made to crystallize at common temperatures by any of the ordinary means. But if a fine glass thread be drawn over a salol crystal, it will induce crystallization; though it loses this power by exposing it to the air for a few minutes, by wiping it with rubber, or by warming it to 40° . The author finds, however, that the temperature range below the melting point in which spontaneous production of crystals is impossible, is quite limited, the liquid being in stable equilibrium except towards a ready formed crystal. To this condition he gives the name *metastable*. At lower temperatures, no nuclei are necessary, the crystals forming spontaneously. Moreover it appears that there is an inferior limit to the quantity of substance required to start the crystallization, the two methods tried, successive dilution on the one hand or the evaporation of progressively more dilute solutions on a platinum wire on the other, giving identical results. In the case of sodium chlorate, a solution containing 107 parts of the salt in 100 of water can be made to crystallize by the introduction of a millionth or even a ten millionth of a milligram. That a minute fragment of ammonium alum causes a solution of potassium alum to crystallize, he explains by supposing the diffusion of the dissolved salt into the solid particle as soon as it comes in contact with the solution. The author concludes that when a system passes from any given condition to a more stable one, it will not pass into the state which under the circumstances is the most stable, but into that which is nearest to the original state.—*Zeitschr. f. physikal. Chemie*, xxii, 289, April, 1897.

G. F. B.

3. *On a Thermochemical Method for determining the Equivalents of Acids and Bases.*—A thermochemical method has been proposed by BERTHELOT by means of which the equivalent of an acid or a base may be determined even when the compound is of unknown composition. For this purpose a given weight, p , of the acid is made up to a given volume, say two liters, with distilled water. A convenient quantity, say 500°C , is taken, and 100°C of potash solution ($\text{KOH} = 2$ liters) added, the heat produced, q_1 , being measured. Then a second 100°C are added and the heat, q_2 , is measured; the process being continued n times until no more

heat is produced on the addition of alkali. The heat thus measured ($q_1 + q_2 + \dots + q_n$) which is the total heat of combination, is one quarter of that which the weight of the acid taken, p , would evolve. From the equation $E = 2000 p / 400 n = 5 p / n$ the equivalent of the acid E can be obtained, approximate to $1/n$ th. Obviously the quantity of alkali added at first should not be sufficient to neutralize all the acid taken, since in that case p_1, p_2 , etc. become zero. If the more accurate determination of the equivalent be desirable, a repetition of the experiment is made, using acid of the same strength but a potash solution only $1/10$ th as strong; the result in this case being approximate to $n/10$ th. With monobasic acids the values of q_1, q_2 , etc. are equal; with many polybasic acids they differ among themselves, decreasing with the successive additions of alkali. The equivalent of a base is fixed in a similar way, these rules applying only to soluble acids or bases yielding soluble salts.—*Ann. Chim. Phys.*, VII, vii, 283, February, 1897.

G. F. B.

4. *On the Action of Potassium and Sodium vapor in coloring the Haloid salts of these metals.*—The blue color produced by the action of the cathode rays on crystals of sodium chloride, so similar to blue rock salt, has suggested to GIESEL the feasibility of coloring such crystals by purely chemical methods. In fact by heating the crystals with the vapor of sodium or potassium in a closed tube, color is readily developed, the particular color being independent of the metal employed. Thus treated, potassium bromide and iodide are colored deep blue; potassium chloride dark heliotrope and sodium chloride yellow to brown, the color appearing to permeate the whole crystal. It is permanent in the air, and also in water so long as the crystal is undissolved. The solution is colorless and gives a colorless residue. On heating, the color disappears. The yellowish brown sodium chloride however, when heated, becomes gradually yellow, red and bluish violet and finally colorless; but by cooling at any particular stage the color then possessed becomes permanent. So that a shade of blue may be thus obtained identical with that of the natural rock salt.—*Ber. Berl. Chem. Ges.*, xxx, 156, February, 1897. Kretz claims to have obtained this result in 1892.—*Ib.* p. 403.

G. F. B.

5. *On the Action of the Silent Electric Discharge on Helium.*—The conditions under which helium will enter into combination have been studied by BERTHELOT. The method used as well as the apparatus were the same as those employed in the case of argon, the graduated tubes permitting the measurement of 5°C of gas to $1/200$ and even to $1/500$ of a cubic centimeter. Comparative experiments were made with nitrogen, argon and helium. Placed in a closed tube over mercury and submitted to the electric discharge for 12 to 15 hours, neither of these gases either combined with the mercury, suffered any molecular condensation or developed fluorescence. In presence of benzene vapor, however, nitrogen developed fluorescence and disappeared in a few hours. Argon

was slowly absorbed, reaching a limit of 15 per cent absorbed in 10 or 12 hours; a brilliant greenish fluorescence being produced, whose spectrum showed the lines of argon, hydrocarbon and mercury. Helium under these conditions showed a characteristic fluorescence of an orange color at the end of 11 hours, the absorbed gas being about 8 per cent. In its spectrum were seen the lines of helium, mercury and hydrocarbons. After 17 hours, 13.7 per cent of the helium was absorbed and after 39 hours 16 per cent, yielding a solid polymerized volatile resin, as do argon and nitrogen. When bisulphide of carbon was used in place of benzene, nitrogen was rapidly absorbed, argon and helium more slowly, with a faint luminosity. After 175 hours 54 per cent of argon was absorbed, and after 192 hours 55.5 per cent of helium; this latter being increased to 68.4 per cent after 210 hours. The result is a carbonaceous mass mixed with sulphur and combined with the absorbed gas, recalling the sulphocyanides. On heating this substance in a vacuum to a red heat, a considerable volume of gas was obtained, which after removal of the regenerated carbon disulphide and a trace of carbon monoxide, gave, when subjected to the action of the electric discharge in presence of benzene, the characteristic reactions of helium. The residual unabsorbed gas behaved similarly. From the identical behavior of the initial gas, of the gas absorbed by carbon disulphide and then regenerated and of the residual gas, the inference is strong in favor of the homogeneity of helium.—*C. R.*, cxxiv, 113, January, 1897.

G. F. B.

6. *Further Note on the Influence of a Magnetic Field on Radiation Frequency*; by OLIVER LODGE, assisted by BENJAMIN DAVIES. Read June 3, 1897, before the Royal Society.*

Referring to a former communication of mine, on the subject of Zeeman's discovery, printed on page 513 of the "Proceedings of the Royal Society" for February 11 this year, vol. lx, No. 367, I wish to add an observation to those previously recorded, as I have recently acquired a concave Rowland grating ($3\frac{1}{2} \times 1\frac{1}{2}$ inch ruled surface, 14,438 lines to inch, 10 feet radius of curvature, being the one used by Mr. George Higgs), of which the spectra of the first and third orders on one side are very satisfactory.

It is said on page 513, "If the focussing is sharp enough to show a narrow, dark reversal line down the middle of each sodium line, that dark line completely disappears when the magnet is excited." With the greater optical power now available, the dark reversal line is often by no means narrow, and though in some positions of the flame it does still tend to disappear or become less manifest when the flame is subjected to a concentrated magnetic field, the reason of its partial disappearance is that it is partially reversed again—*i. e.*, that a third bright line, as it were, makes its appearance in the midst of the dark line, giving a triple appearance to each sodium line.

More completely stated, the phenomena are as follows: After

* From an advance proof sent by the author.

obtaining each sodium line with a prominently double aspect by manipulating the flame, the magnet is excited, and the dark band in the midst of each sodium line is then seen to widen out considerably in the region of most intense magnetisation, while a bright intrusion line makes its appearance. On closer examination this new line is seen to be double, by reason of a dark division down its middle; and I apprehend that with still more magnetic power this dark band might itself open out into two; but this last phenomenon I have not yet observed.

The whole sodium group is thus seen as if it were octuple. The effect is not due to a mere mechanical disturbance or re-arrangement of the gases of the flame by the agency of magnetism; because a nicol, placed in the rays emanating transversely to the magnetic lines of force, cuts off nearly all the visible magnetic effect when oriented so as to get rid of light whose plane of polarisation contains the lines of force—that is, of oscillations or revolutions whose electrical components are across or around the magnetic lines. That it does not cut off every trace of the effect appears to be due to the fact that the field of force is not strictly uniform, and so its lines are not strictly parallel.

The following is a summary of the different appearances that may be seen according to the state of the flame and the strength of the field:—

At low temperature, and with the flame forward in the field, when each sodium line is sharp and single, magnetism widens it, and with a little more power doubles it, causing a distinct dark line down its middle. The same effect occurs with lithium and thallium lines.

At higher temperature, and with the flame partially behind the field, when each sodium line appears as a broad hazy-edged double, magnetisation greatly widens the doubling, pushing asunder the bright components very markedly: stronger magnetisation reverses the middle of the widened dark band, giving a triple appearance; stronger magnetisation still reverses the middle once more, giving a quadruple appearance to the line. In every case a nicol, suitably placed, cuts off all the magnetic effect and restores the original appearance of the line.

A curious circumstance is that although both lines D_1 and D_2 show the same effect, D_1 , *i. e.*, the less refrangible line, shows it best and most sharply. I should describe the effect on D_2 as a coarse widening of considerable amount, but without very clear definition; whereas the widening of D_1 , though perhaps no greater in amount, is decidedly better defined. There is no doubt but that, with my grating, D_1 is the line at which one finds oneself usually looking in order to see the details of the change best; and I can hardly suppose this to be subjective to the grating. I hope to show the effects at the soiree next Wednesday.

[The same thing is seen when salts of lithium or of thallium are introduced into the flame, and the components of the doubled

red lines are more widely separated than the components of the doubled green lines, the effect being proportional to wave-length. The most interesting line to try was the red cadmium line, since this has been proved to be of specially simple constitution by Michelson. We have recently been able to get the cadmium spectrum well developed by means of a sort of spark arc between the magnet poles, maintained by an induction coil excited by an alternating machine; and we find that the magnetic doubling of the chief lines occurs in precisely the same way with the spark spectrum as with the flame spectrum, and that the red cadmium line behaves in the same way as the others. The magnetic effect is better seen, from a direction perpendicular to the line of force, when a nicol is interposed in the path of the light, but rotation of the nicol through 90° cuts it entirely off, accurately so when a small spark is the source of light.—May 31.]

II. GEOLOGY AND MINERALOGY.

1. *Recent publications of the U. S. Geological Survey.**—The Seventeenth Annual Report for 1895-96 has three parts, all issued. Besides the paper already noted, Part I contains the following: *Magnetic Declination in the United States*, by Henry Gannett, pages 237, with map showing distribution of the magnetic declination in the United States in 1900. *Further Contributions to the Geology of the Sierra Nevada*, by H. W. Turner, pages 241, plates 30. Although much of this paper treats of structural geology, the larger part is petrographical. *Report on the Coal and Lignite of Alaska*, by W. H. Dall, pages 143, plates 11, with an appendix on the fossil plants by F. H. Knowlton. Another on the Paleozoic fossils by Charles Schuchert, and a third on the Mesozoic fossils by Prof. A. Hyatt. G. F. Becker and Dr. Dall were together on the Alaskan trip and Becker's report on the gold of that country will appear in the Eighteenth Annual. *The Glacial Brick Clays of Rhode Island and Southern Massachusetts*, by N. S. Shaler, J. B. Woodworth, and C. F. Marbut, pages 51, plates 2. This paper supports the view that the glacial period was divided into three great epochs of ice action separated from one another by very long intervals. *The Faunal Relations of the Eocene and Upper Cretaceous on the Pacific Coast*, by T. W. Stanton, pages 56, plates 5. Notwithstanding their conformability, Mr. Stanton recognizes a marked paleontological break between the Upper Cretaceous and the Eocene of California and Oregon.

Part II of the Seventeenth Annual, Economic Geology and Hydrography, contains the following papers:—*The Gold Quartz Veins of Nevada City and Grass Valley, California*, by W. Lindgren, pages 249, plates 24. This paper, although chiefly economic, contains much petrography. A folio of the region has

* Issued since January, 1897. See list in this Journal for February, 1897, page 153.

been published by the same author. *Geology of Silver Cliff and the Rosita Hills, Colorado*, by Whitman Cross, pages 160, plates 11, and *The Mines of Custer County, Colorado*, by S. F. Emmons, pages 67, plate 1, refer to the same region. The observations for these papers were made chiefly in 1883. The rapid decline of the district as a mining camp has greatly increased the difficulty of obtaining satisfactory data. *Geologic Section Along the New and Kanawha Rivers in West Virginia*, by M. R. Campbell and W. C. Mendenhall, pages 38, plates 12. *The Tennessee Phosphates*, by C. W. Hayes, pages 38, plates 6. There are three papers on hydrography. Those by Gilbert and Leverett have already been mentioned.* The final paper is a *Preliminary Report of the Artesian Waters of a Portion of the Dakotas*, by N. H. Darton, pages 93, plates 39.

The following monographs have been issued:—Monograph XXVIII, *Geology of the Denver Basin in Colorado*, by S. F. Emmons, Whitman Cross, and G. H. Eldridge, pages 556, plates 33, four of which are maps on a scale $\frac{1}{125,000}$, showing the topography, areal, economic and structural geology. The geology, excepting that of the Denver formation, is chiefly by Emmons and Eldridge. The Denver formation and the petrography are by Mr. Cross.

Chapter VII on Paleontology was contributed by Mr. F. H. Knowlton and Prof. O. C. Marsh.

Monograph XXVIII, *The Marquette Iron-bearing District of Michigan*, by C. R. Van Hise and W. S. Bayley, with a Chapter on the Republican Trough by H. L. Smyth, pages 608, plates 36, and atlas of 39 maps. The geology is chiefly by Van Hise and the petrography by Bayley. The volume is most handsomely illustrated.

The following bulletins have been issued:—

No. 137, *The Geology of the Fort Riley Military Reservation and Vicinity, Kansas*, by Robert Hay, has 35 pages.

No. 139, *Geology of the Castle Mountain Mining District, Montana*, by W. H. Weed and L. V. Pirsson, contains 164 pages. A geological map, based on the topography as outlined by the Transcontinental survey, shows the distribution of a large number of rocks from the Algonkian to the Miocene inclusive with a full series of acid and basic eruptives.

No. 141, *The Eocene Deposits of the Middle Atlantic Slope in Delaware, Maryland and Virginia*, by W. B. Clark, has 166 pages, and 40 plates. The geological and paleontological data, including a considerable number of new species, are fully illustrated and discussed, and Prof. Clark is decidedly of the opinion that the Eocene deposits of the Middle Atlantic slope represent the greater portion of the Eocene series of the Gulf, its upper members alone excepted.

No. 143, *Bibliography of Clays and the Ceramic Arts*, by J. C. Branner, has 114 pages.

* This Journal, February, 1897, p. 154.

No. 144, *The Moraines of the Missouri Coteau and their Attendant Deposits*, by J. E. Todd, has 71 pages and 21 plates. The paper includes a map of the glacial phenomena in parts of North and South Dakotas, and numerous illustrations of the three moraines and other various attendant deposits in that portion of the great terminal moraine belt.

The following folios have been issued:—

No. 28, *Piedmont, Maryland and West Virginia*, latitude 39° to $39^{\circ} 30''$, longitude 79° to $79^{\circ} 30''$, by N. H. Darton and J. A. Taff.

No. 30, *Yellowstone National Park, Wyoming*, embracing four sheets, Gallatin, Canyon, Shoshone and Lake, on the scale of $\frac{1}{125,000}$, by Arnold Hague, J. P. Iddings and W. H. Weed.

No. 32, *Franklin, Virginia and West Virginia*, latitude $38^{\circ} 30''$ to 39° , longitude 79° to $79^{\circ} 30''$, by N. H. Darton.

The Geological Survey has already issued 166 topographic sheets, of which 27 have been issued since February 1st. By Act of Congress, these have recently been placed on sale at 5 cents apiece, or \$2.00 a hundred copies. J. S. D.

2. *The Pleistocene Features and Deposits of the Chicago Area*; by FRANK LEVERETT, U. S. Geol. Survey. (Bull. No. II, Geol. and Nat. Hist. Survey of the Chicago Acad. Sciences), pp. 1-87, May, 1897.—Mr. Leverett's minute knowledge of the surface features of Illinois and neighboring States gives special value to this detailed analysis of the Pleistocene deposits in relation to ancient glacial phenomena.

In his classification of the drift sheets, as marks of chronology, he follows and amplifies the outline of Prof. Chamberlin, already published. He recognizes fifteen stages and substages in the glacial history of the region, as follows:—

“Outline of the drift sheets and intervals.

1. Oldest recognized drift sheet—the Albertan of Dawson.
2. First, or Aftonian, interval of recession or deglaciation.
3. Kansan drift sheet of the Iowa geologists.
4. Second interval of recession or deglaciation.
5. Illinoian drift sheet.
6. Third, or preloessial, interval of recession or deglaciation.
7. Iowan drift sheet and main loess deposit.
8. Fourth, or post-loessial, interval of recession or deglaciation.
9. Early Wisconsin drift sheets.

Substage 1. Shelbyville morainic system.

Substage 2. Champaign morainic system.

Substage 3. Bloomington morainic system.

Substage 4. Marseilles morainic system.

10. Fifth interval of recession, shown by shifting of ice lobes.

11. Late Wisconsin drift sheets.

Substage 1. Great bowlder belts and accompanying moraines.

Substage 2. Valparaiso morainic system.

Substage 3. Lake-border morainic system.

12. Lake Chicago submergence.
13. Emergence of plain, covered by Lake Chicago.
14. Partial resubmergence of plain, covered by Lake Chicago.
15. The present stage of Lake Michigan." H. S. W.

3. *A new fossil Pseudoscorpion*.—Prof. HANS BRUNO GEINITZ of Dresden has sent out a preliminary notice of a unique fossil pseudoscorpion, named by him *Kreischeria wiedei* Gein. It was recently discovered in the lower layers of the Sigillaria zone in the "Morgenstern" mine, at Reinsdorf near Zwickau. A full description is promised in the next number of the *Zeitschrift der deutschen geologischen Gesellschaft*. The length of the body, without jaws, feelers or legs, is 50 millimeters, and it is about 28^{mm} wide at its most expanded part. The specimen will be deposited in the K. Mineralogisch. Museum in Dresden.

H. S. W.

4. *Catalogus Mammalium tam viventium quam fossilium*; a Dr. E.-L. TROUËSSART, Nova Editio (prima completa), Berlin, 1897 (R. Friedländer & Sohn).—Fasciculus II of this work, pp. 217-452, has recently been issued. It contains the Carnivora, Pinnipedia, Rodentia I. Protrogomorpha et Sciuromorpha.

H. S. W.

5. *Brief Notices of some recently described Minerals*.—LEONITE. A new sulphate described by Tenne from the salt deposits of Leopoldshall; it corresponds to bloedite but contains potassium instead of sodium. It crystallizes in thick tabular crystals belonging to the monoclinic system; color pale yellowish, reddish or gray. Analysis led to the formula $MgSO_4 \cdot K_2SO_4 + 4 aq$. Named after Director Leo Strippelmann.—*Zs. deutsch. geol. Gesellschaft*, xlviii, 632, 1896.

QUIROGITE. A sulphide of lead and antimony described by F. Navarro from the San Andres mines, Georgina, Sierra Almagrera, Province of Palmeria, Spain. It resembles galena but crystallizes in the tetragonal system, with a hardness of 3 and a specific gravity of 7.23; color gray on the surface but luster metallic on freshly fractured surfaces. An analysis gave:

S 17.51, Sb 9.69, Pb 63.89, Fe 6.30.

If the iron sulphide is to be regarded as foreign, the mineral consists of PbS and Sb_2S_3 in the ratio of 23:2.—*Anal. Soc. Espan.*, xxiv, 1896, in *Bull. Soc. Min.*, xx, 163, 1897.

DICKSBERGITE. A name given by Igelström to a supposed new mineral occurring with cyanite at Dicksberg in the Ransät parish, Wermland, Sweden. It has since been shown by Weibull and Upmark to be rutile.—*Geol. För. Förh.*, xviii, 231, 523, 1896.

MALTESITE. A variety of andalusite resembling chiastolite from eastern Finland, described by Sederholm. It occurs in mica schist in crystals of remarkable size, varying from 1.5 to 5 centimeters across.—*Geol. För. Förh.*, xix.

MANGANDALUSITE. Bäckström has given this name to a variety of andalusite occurring in the muscovite-quartzite of the Vestana

region in Sweden. It is characterized by containing 6.9 p. c. of Mn_2O_3 . In its pleochroism it differs from ordinary andalusite.

FÜGGERITE. A mineral closely related to gehlenite, described by E. Weinschenk. It occurs as a contact mineral in the Monzoni region of the Fassathal. It crystallizes in tetragonal prisms with perfect basal cleavage; color white and greenish; specific gravity 3.18. An analysis by Mayr gave :

| SiO ₂ | Al ₂ O ₃ | Fe ₂ O ₃ | MgO | CaO | Ma ₂ O | |
|------------------|--------------------------------|--------------------------------|------|-------|-------------------|-------------------------------------|
| 34.04 | 17.97 | 3.49 | 4.89 | 37.65 | 2.04 | K ₂ O, MnO tr. = 100 20. |

Named after Prof. E. Fugger of Salzburg.—*Zeitschr. Kryst.* xxvi, 577, 1896.

MUNKFORSITE. A mineral of uncertain character from the Ransät parish, Wermland, Sweden, imperfectly described by Igelström. It occurs with cyanite in white bladed forms; hardness=5. Analysis shows the presence of SO₃, P₂O₅, Al₂O₃, CaO, but little confidence can be placed in the numbers given. A relation to svanbergite is suggested.—*Zeitschr. Kryst.*, xxvi, 601, 1896.

BISMUTOSMALTITE. A variety of skutterudite from Zschorlau near Schneeberg, peculiar in its large percentage of bismuth. Described by Frenzel in *Min. petr. Mitth.*, xvi, 525, 1896.

6. *The Bendegó Meteorite.*—Dr. O. A. DERBY has recently published (Archivos do Museu Nacional do Rio de Janeiro, vol. ix) the results of a highly interesting and exhaustive study of the remarkable meteoric iron of Bendegó, in the province of Bahia, Brazil. The accounts of the early history of this wonderful mass are most interesting. It was discovered in 1784 and a year later a rude truck was built with the idea of removing it. This work proved to be of great difficulty, and after the mass had been dragged about 100 yards along the bed of the rivulet called the Bendegó, it was finally abandoned. It was visited again in 1811 by Mr. Mornay in company with Signor Botelho, the discoverer, who made measurements of its size, from which its cubic contents were estimated to be 28 cubic feet and its weight 14,000 pounds. It was again visited by Spix and Martius in March, 1818, who estimated the volume at 31 to 32 cubic feet, and the weight at 17,300 pounds. They removed some fragments, the largest of which was deposited in the Munich museum. Many years later, the extension of the railway brought up again the question of its removal, and finally in 1888 it was deposited in Rio Janeiro. The work of removal involved great care and called for much engineering skill.

Of the original fall of this great mass nothing is known, but the author concludes that it certainly antedated by a long period the time of its discovery. Some interesting local traditions in this connection are recorded. The weight of the mass, after the removal by cutting of a piece of 62 kilos, is stated to be 5,300 kilos (11,660 pounds); this is somewhat less than first estimated, but still gives it the first place among the meteorites of the great

museums of the world. The author describes with all necessary fullness the external appearance of the mass, certain portions of the surface of which seem to correspond in direction to the internal crystalline structure. The Widmanstätten figures are finely developed by etching; and numerous nodules of troilite were observed. These last have left by weathering a number of hemispherical and cylindrical cavities, which are a characteristic feature of the iron.

In connection with Dr. Hussak and Dr. Guilherme Florence, a minute study, leading to many interesting results, has been made of the different forms of nickel, iron and associated minerals present, namely: Kamacite and tænite; also cohenite, rhabdite; and further troilite, schreibersite, chromite and hypersthene. In addition to these species identified, a peculiar feature are small black spherical globules obtained from the rhabdite, which range from 0.1 to 0.2^{mm} in length and from 0.004 to 0.005^{mm} in thickness. Some of these are hollow spheres and others are developed in successive layers, like an onion. They have a fused appearance, and it is suggested that they may have resulted from the fusion of the phosphides, which are evidently the first mineralogical element to be individualized in the metallic magma. These metallic globules sometimes show cubic or octahedral crystalline faces.

The presence of fine etched lines, resembling file markings, is noted in the kamacite, especially in the vicinity of the troilite nodules. Also associated with these are raised lines, similarly arranged; these are called Bendegó lines. They consist of exceedingly delicate, perfectly regular plates of brilliant white metal resembling taenite, that stands out in relief on the etched surface. The various observed direction of these lines are explained as due to twinning, and Dr. Hussak finds evidence of polysynthetic twinning lamellæ parallel to the faces of the hexoctahedron (421).

III. MISCELLANEOUS SCIENTIFIC INTELLIGENCE.

1. *American Association for the Advancement of Science.*—The forty-sixth meeting of the American Association will be held at Detroit, Michigan, from August 9th to 14th. Dr. Wolcott Gibbs of Newport is the President-elect. The scientific sessions are to be in the Central High School and the hotel headquarters at "The Cardillac." The local Secretary, who has charge of transportation, hotel accommodations, etc., is Mr. John A. Russell, 401 Chamber of Commerce, Detroit. The Permanent Secretary is Prof. F. W. Putnam of Salem, Mass.

The interest of the coming meeting will be largely increased by the fact that the British Association is to meet this summer at Toronto, and it is expected that the members of the A. A. S. will go in a body to Toronto to join in welcoming the members of the B. A. A. S. to America.

2. *The Development of the Frog's Egg, an Introduction to Experimental Embryology*; by THOMAS HUNT MORGAN, pp. 192. New York, 1897 (The Macmillan Company).—Although the frog's egg has long been a favorite subject of investigation in both normal and experimental embryology, this book by Prof. Morgan is the first to give a summary of the experimental work of many investigators. Marshall, in his *Vertebrate Embryology*, has given a good and fairly well illustrated account of the normal development, particularly of the later stages, but in the work here noticed we have, especially for the earlier stages, a full account of the normal development followed by the results of numerous experiments by various investigators, including those of the author himself. Prof. Morgan's book gives us a much needed text-book for both student and instructor, and it should stimulate and greatly aid investigation by pointing out the wide field the frog's egg still offers for embryological research.

S. I. S.

OBITUARY.

ALFRED MARSHALL MAYER, Professor of Physics in the Stevens Institute of Technology, Hoboken, N. J., died on the 13th of July, in the sixty-first year of his age. He had been in failing health for some months, but had continued to discharge the duties of his professorship until February, and later increasing weakness and exhaustion caused his retirement to his country residence, Maplewood, South Orange, N. J., where his life came to a close in consequence of an attack of an apoplectic nature, from which he did not rally.

Professor Mayer was born in Baltimore, Md., Nov. 13, 1836, and received his education at St. Mary's College, Baltimore. After leaving this institution, in 1852, he spent two years in the office and workshop of a mechanical engineer, where he acquired a knowledge of mechanical processes and the use of tools, for which he had a natural aptitude. His experience here was of great service to him in his subsequent career. This was followed by a course of two years in a chemical laboratory, where he obtained a thorough knowledge of analytical chemistry. In 1856 he was made Professor of Physics and Chemistry in the University of Maryland, and three years later he entered upon a similar position in Westminster College, Mo., where he remained two years. In 1863 he went abroad, and entered the University of Paris, where he spent two years in the study of physics, mathematics and physiology. While in Paris he was a pupil of the distinguished physicist Regnault. After his return to this country he occupied a chair in Pennsylvania College, Gettysburg, and later in Lehigh University, Bethlehem, where he was in charge of the department of astronomy, and superintended the erection of an observatory. In 1869, an expedition was sent by the U. S. Nautical Almanac office to Burlington, Iowa, to observe the

eclipse of Aug. 7. Professor Mayer was placed in charge of the expedition, and made a large number of successful photographs. In 1871, he was called to the professorship of Physics in the Stevens Institute of Technology, which position he held until the close of his life.

Professor Mayer was an enthusiastic and active investigator, and a prolific writer upon scientific subjects. He had the command of a clear and graceful style, and possessed in a remarkable degree the power of presenting scientific subjects in a perspicuous and interesting manner. He made numerous contributions to various journals, cyclopædias, and other scientific publications, but the memoirs in which he embodied the results of his own researches were chiefly published in the *American Journal of Science*. His papers published in this Journal, since 1870, number forty-seven titles, covering nearly four hundred closely printed pages, not counting various notes and minor contributions. While embracing a great variety of topics in physics, his studies were more actively pursued in the departments of electricity and electro-magnetic phenomena, in optics, especially photometry and color-contrasts, but more particularly in acoustics, which was a favorite field of research, in which his discoveries gave him the prominence and authority of a specialist. His acoustical researches form a connected series of papers, in ten numbers, amounting to nearly one half the total volume of his contributions. The following somewhat abbreviated titles will indicate their purport:—The translation of a vibrating body causes it to give a wave-length differing from that produced by the same vibrating body when stationary (1872): a method of detecting the phases of vibration in the air surrounding a sounding body; and thereby measuring directly in the vibrating air the length of its waves and exploring the form of its wave-surface, resulting in the invention of the topophone (1872): a simple and precise method of measuring the wave-lengths and velocities of sound in gases; and on an application of the method in the invention of an acoustical pyrometer (1872): the experimental determination of the relative intensities of sounds; the measurement of the powers of various substances to reflect and to transmit sonorous vibrations (1873): experimental confirmation of Fourier's theorem; experimental illustration of Helmholtz's theory of audition; experiments on the supposed auditory apparatus of the mosquito, in which it is shown that the fibrils of the antennæ of the male mosquito vibrate sympathetically to sounds having the range of pitch of sounds emitted by the female mosquito; suggestions as to the function of the spiral scale of the Cochlea; six experimental methods of sonorous analysis; curve of musical note formed from six sinusoids of the first six harmonics; curves for various consonant intervals; experiments in which motions of a molecule of air are derived from these for six elementary vibrations of a musical note (1874): determination of the law connecting pitch of sound with the duration of residual

sensation; determination of the numbers of beats throughout the musical scale which produce the greatest dissonances; application of these laws by means of rotating perforated disks, and quantitative application of them to musical harmony (1874): experiments on the reflection of sound from heated flames and heated gases (1874): obliteration of one sound by simultaneous action of a more intense and lower sound; discovery that a sound even intense cannot obliterate sensation of a sound of lower pitch (1876): acoustic repulsion (1878): determination of the smallest consonant intervals among simple tones, and application to deduce the duration of residual sonorous sensations (1894): variation in the modulus of elasticity with change of temperature determined by transverse vibrations of bars at various temperatures; the acoustical properties of aluminium, showing that the metal is unsuited for musical instruments on account of the rapid and large changes in its elasticity by change of temperature (1896). In an elaborate paper published in the third volume of the *Memoirs of the National Academy of Sciences*, 1884, he gave a method of precisely measuring the vibratory periods of tuning-forks and determining the laws of their vibration, with their applications in chronoscopes for measuring the velocity of projectiles.

Among other papers published by Professor Mayer in this *Journal* may be mentioned: *Researches in electro-magnetism*, showing the changes in dimensions of iron and steel bars by magnetization; method of measuring electrical conductivity by means of two equal and opposed electrical currents (1870, 1873): on the electro-tonic state; on a method of fixing magnetic spectra (1871): new form of lantern galvanometer; mode of tracing the boundary of a wave of conducted heat (1872): on the composite nature of the electric discharge (1874): method of delineating the isothermal lines of the solar disk (1875): experiments with floating magnets (1878): the well-spherometer (1886): the pendulum electrometer; electric potential as measured by work; the spring balance electrometer; experimental proof of Ohm's law; cubical expansion of solids, by vessels or hydrometers made of the material of these solids (1890): illuminating power of flat petroleum flames; physical properties of hard rubber (1891): simultaneous contrast-color; photometer for lights of different color (1893): researches on the Röntgen rays (1896); equilibrium of forces acting in the flotation of disks and rings of metal, with determinations of surface tension (1897).

He also published "*Lecture Notes on Physics*" (Philadelphia, 1868); "*The Earth a Great Magnet*" (New Haven, 1872); "*Light*" (New York, 1877); "*Sound*" (New York, 1878); "*Sport with Gun and Rod in American Woods and Waters*" (1883).

Professor Mayer received the degree of Ph.D. from the Pennsylvania College in 1866. During the year 1873 he was one of the associate editors of this *Journal*. In 1872 he was elected a

member of the National Academy of Sciences, and was connected with many other scientific societies, among which may be mentioned the American Philosophical Society, the American Academy of Arts and Sciences, the New York Academy of Sciences, the American Metrological Society. He was also a corresponding member of the British Association for the Advancement of Science, and a Fellow of the American Association of the same name.

Professor Mayer's scientific work was marked by strongly characteristic traits. He possessed great ingenuity and skill in construction, and a remarkable degree of delicacy and precision as an experimenter, which enabled him to obtain results that will have a high and permanent value in science. Beyond his scientific accomplishments he was a man of wide and refined culture, with a genial presence, and social qualities which made him a delightful companion and endeared him to his friends. He leaves a wife and one son.

A. W. W.

PROFESSOR A. DES CLOIZEAUX, the eminent French Mineralogist, died at Paris on the 6th of May, at the age of seventy-nine years. His contributions to Mineralogy, especially on the crystallographic and optical side, were very numerous and all of the highest character. The development of the methods for the study of the optical characters of crystals is largely due to him, and his three classical memoirs devoted to this subject and giving the results of the optical examination of a very large number of minerals and artificial salts, will always hold the first place in the literature; they were published in 1857, 1858 and 1864. The *Manuel de Minéralogie* is also a profound work containing the results of his own original observations. The first volume of 572 pages, devoted to the Silicates, was published in 1862; two portions of the second volume were issued much later, namely in 1874 and 1894 respectively. Professor Des Cloizeaux was a man of noble character and of charming personality; he was honored not only by those who had the privilege of his acquaintance but by the much larger number who knew him only through his scientific work.

JULIUS SACHS, Professor of Botany at Würzburg, died on May 29, in his sixty-fifth year.

Notice.—The Director of the Imperial Museum of Natural History has the honour of notifying that Mr. *Aristides Brezina* has ceased to be the chief of the mineralogical and petrographical section and that all letters, specimens and other consignments, especially those concerning meteorites, are to be addressed in future to the mineralogical and petrographical section of the Museum or to the chief of the same, at present Professor *Fritz Berwerth*, Vienna I Burgring 7.

MIDSUMMER MINERALS.



How refreshing it is in midsummer to turn from ugly meteorites, or obscure crystals revealed only by the lens, to the cooling verdure of **Utah Variscite**! The charms of such beauty even the most scientific mineralogist cannot resist. When you are showing your collection what new enthusiasm your companion manifests! How his eye brightens as it rests upon the gorgeous polished slab of Variscite in your drawer! It reminds you of the first rays of golden sunshine after a week of storm.

While we have recently received an unusual number of remarkably rare minerals, we will reserve mention of them till another time, and present this month only minerals thoroughly attractive to everyone.

RICH UTAH VARISCITE!

Our recent large purchase of this mineral is being rapidly finished up into polished sections of extraordinary beauty. Over 100 choice polished sections, large and small, will be received from our lapidary during August. The combination of colors is most pleasing; rich greens, delicate yellows, pale grayish blue, brown and white are often seen in the same specimen. **Wardite** and **Amphithalite** are common associates, the curious little pisolitic nodules of the former adding no little to the interest of the specimens. Excellent polished specimens, \$1.50 to \$10.00; rough specimens, 25c. to \$5.00; **Wardite** in choice specimens, 50c. to \$5.00.

GRAVES MT. RUTILES.

While the recent work at the old Georgia Rutile locality has yielded a splendid large lot of choice specimens, all of which have come to us, but very few of the grand, heroic-size crystals remain in stock, and no more have been found. Few midsummer luxuries could give more pleasure to a true mineralogist than one of these noble crystals, unless, indeed, he were to select a suite of the smaller, more brilliant crystals on the matrix of which our splendid stock is a marvel to every beholder. Loose crystals, 25c. to \$20.00 (a few still higher); superfine matrix specimens, 25c. to \$12.50.

JAPANESE STIBNITES.

A few excellent specimens were received during July. One fine group of large, terminated crystals, \$15.00; loose crystals, well terminated, 50c. to \$2.50.

COLEMANITES.

A fine, large lot at lowest prices ever known in New York; 10c. to \$1.50.

UNRIVALLED GOLDEN CALCITES.

Some idea of our great success in distributing fine specimens may be formed by noting that we sold some 500 golden calcites within three weeks. No other establishment of the kind in the world handles such large quantities of fine minerals. Our shipments from Joplin (chiefly golden calcites) during six months aggregated 163 boxes, many of which were of large size (200 to 500 lbs. each), and the total of our freight bills alone has doubtless exceeded the aggregate payments made by all other dealers for Joplin minerals within a year. Fine Joplin calcites were found last summer, but if you have not bought during 1897 any of those which we alone secured from the great cave, you have **no idea** of how **incomparably** superior these latest crystals are to all other finds. Our stock is still replete in crystals of the very best quality at 10c. to \$10.00, the prices being far lower than they were a few months since.

GEO. L. ENGLISH & CO., Mineralogists,
64 East 12th St., New York City.

CONTENTS.

| | Page. |
|---|-------|
| ART. X.— <i>Tamiobatis vetustus</i> ; a new Form of Fossil Skate; by C. R. EASTMAN. (With Plate I.)..... | 85 |
| XI.—Florenzia Formation; by O. H. HERSHEY..... | 90 |
| XII.—Native Iron in the Coal Measures of Missouri; by E. T. ALLEN..... | 99 |
| XIII.—Bixbyite, a new Mineral, and Notes on the Associated Topaz; by S. L. PENFIELD and H. W. FOOTE..... | 105 |
| XIV.—Composition of Ilmenite; by S. L. PENFIELD and H. W. FOOTE..... | 108 |
| XV.—Separation of Aluminum and Beryllium by the action of Hydrochloric Acid; by F. S. HAVENS..... | 111 |
| XVI.—Igneous Rocks of the Leucite Hills and Pilot Butte, Wyoming; by W. CROSS..... | 115 |
| XVII.—Styrolites; by T. C. HOPKINS..... | 142 |
| XVIII.—Extinct Felidæ; by G. I. ADAMS..... | 145 |

SCIENTIFIC INTELLIGENCE.

Chemistry and Physics—Electrical Convection of certain Dissolved Substances, PICTON and LINDER, 150.—Phenomena of Supersaturation and Supercooling, OSTWALD: Thermochemical Method for determining the Equivalents of Acids and Bases, BERTHELOT, 151.—Action of Potassium and Sodium vapor in coloring the Haloid salts of these metals, GIESEL: Action of the Silent Electric Discharge on Helium, BERTHELOT, 152.—Further Note on the Influence of a Magnetic Field on Radiation Frequency, LODGE and DAVIES, 153.

Geology and Mineralogy—Recent publications of the U. S. Geological Survey, 155.—Pleistocene Features and Deposits of the Chicago Area, F. LEVERETT, 157.—A new fossil Pseudoscorpion, H. B. GEINTZ: Catalogus Mammalium tam viventium quam fossilium, E.-L. TROUSSART: Brief Notices of some recently described Minerals, 158.—The Bendegó Meteorite, O. A. DERBY, 159.

Miscellaneous Scientific Intelligence—American Association for the Advancement of Science, 160.—Development of the Frog's Egg, an Introduction to Experimental Embryology, T. H. MORGAN, 161.

Obituary—ALFRED M. MAYER, 161.—A. DES CLOIZEAUX: JULIUS SACHS, 164.

File

1897-1898

VOL. IV.

SEPTEMBER, 1897.

Established by BENJAMIN SILLIMAN in 1818.

THE
AMERICAN
JOURNAL OF SCIENCE.

EDITOR: EDWARD S. DANA.

ASSOCIATE EDITORS

PROFESSORS GEO. L. GOODALE, JOHN TROWBRIDGE,
H. P. BOWDITCH AND W. G. FARLOW, OF CAMBRIDGE,

PROFESSORS O. C. MARSH, A. E. VERRILL AND H. S.
WILLIAMS, OF NEW HAVEN,

PROFESSOR GEORGE F. BARKER, OF PHILADELPHIA,
PROFESSOR H. A. ROWLAND, OF BALTIMORE,
MR. J. S. DILLER, OF WASHINGTON.

FOURTH SERIES.

VOL. IV—[WHOLE NUMBER, CLIV.]

No. 21.—SEPTEMBER, 1897.

WITH PLATES II-X.

NEW HAVEN, CONNECTICUT.

1897.

TUTTLE, MOREHOUSE & TAYLOR, PRINTERS, 125 TEMPLE STREET.

Published monthly. Six dollars per year (postage prepaid). \$6.40 to foreign subscribers of countries in the Postal Union. Remittances should be made either by money orders, registered letters, or bank checks.

TASMANIA.

The Island of Flinders, off the north coast of Tasmania, is practically unknown as a mineral locality except to a few Australian collectors. Yet a trip recently made to the Island by a gentleman collecting exclusively for us, yielded

GMELINITE

In magnificent crystals whose size, perfection and beauty excel those of any known examples of this rare species. They occur in cavities in a hard basalt, often having a background of *clear, gem-like Analcites*. Associated with tufts of *Natrolite*, they make rich and handsome specimens. They possess fine lustre and are sometimes $\frac{1}{8}$ inch across.

SPHAEROSTILBITE

Occurs in minute but bright balls, scattered over Natrolite, and also as a thin, transparent coating over primitive form Calcite crystals.

NATROLITE AND ANALCITE

in very pretty association. The clearness and brilliancy of the groups of the latter mineral are unrivalled.

Prices are low, as with zeolites from other localities. 50c. to \$3.00 for fine specimens, though the best of the Gmelinites are \$6.00 to \$9.00.

COLLECTIONS OF MINERALS

For Schools, Teachers, Students and Prospectors.

Send for price list.

 We make a specialty of preparing educational collections, and guarantee accuracy of labelling and strictly scientific arrangement.

BOOKS

On all subjects of Science and Medicine. *Catalogues free.* Please mention subject. The following titles are selected from recent lists:

| | |
|---|--------|
| Boetius de Boot, A. Histoire des Pierrieres, 1644..... | \$3.50 |
| Brown, T. Illustrations of the Fossil Conchology of Great Britain and Ireland. London, 1849..... | 5.00 |
| Busk, Geo. A Monograph of the Fossil Polyzoa of the Crag. London, 1859..... | 4.00 |
| Conrad, Blake, et al. Geology of the Pacific R. R. Survey..... | 3.00 |
| Egleston, T. Metallurgy of Silver, Gold, and Mercury in the U. S. 2 vols. New York, 1887..... | 9.00 |
| Greenwell, G. C. Practical Treatise on Mine Engineering. 1855..... | 2.00 |
| Howe, H. M. The Metallurgy of Steel. N. Y., 1891..... | 6.00 |
| Karsten System Der Metallurgie, 5 vols., and Atlas. Berlin, 1831..... | 7.00 |
| Kohn, F. Iron and Steel Manufacture. London, 1869..... | 3.50 |
| Macfarlane, J. The Coal Regions of America, their Topography, Geology, etc. N. Y., 1873..... | 3.00 |
| Phillips, J. Figures and Descriptions of the Palaeozoic Fossils of Cornwall, Devon, and West Somerset. London, 1841..... | 3.50 |
| Percy. Metallurgy of Gold and Silver. London, 1880..... | 5.00 |
| Richthofen, F. The Natural System of Volcanic Rocks. San Francisco, 1868..... | 2.50 |
| Rosenbusch. Mikroskopische Physiographie. Stuttgart, 1873..... | 3.50 |

A. E. FOOTE,

WARREN M. FOOTE, Manager.

1317 ARCH STREET,
PHILADELPHIA, PA., U. S. A.

Established 1876.

Handwritten signature or scribble at the top of the page.

T H E

AMERICAN JOURNAL OF SCIENCE

[FOURTH SERIES.]



ART. XIX.—*Principal Characters of the Protoceratidæ*; by
O. C. MARSH. Part I. (With Plates II-VII.)

THE genus *Protoceras*, described by the writer in 1891, from the Miocene of South Dakota, is now known to include some of the most interesting extinct mammals yet discovered. It likewise represents a distinct family, and thus deserves careful investigation and description.* Before this discovery, no horned artiodactyles were known to have lived during Miocene time, and *Protoceras* is thus the earliest one described. The type specimen, moreover, had a pair of horn-cores on the parietals, and not on the frontals as in modern forms of this group. The animal was apparently a true ruminant, nearly as large as a sheep, but of more delicate proportions.

The first skull found, the type specimen of the genus *Protoceras*, belonged to a female, as later discoveries demonstrated. The skull of the male proved still more remarkable, and especially resembles the male skull of the Eocene *Dinocerata* in having several pairs of horn-cores or protuberances upon the head, a feature hitherto unknown among the *Artiodactyla*. It is an interesting fact, moreover, that one pair of these horn-cores of *Protoceras* is on the maxillaries, as in *Dinocerata*, while the posterior pair, as in that genus, is on the parietals.

* This Journal, vol. xli, p. 81, January, 1891; and also, vol. xlvi, p. 407, November, 1893.

The resemblance in the two skulls is further enhanced by the absence of upper incisors and the presence of large canine tusks, forming together a striking similarity in important features, between skulls pertaining to animals of two distinct orders, and from widely different geological horizons. The skull of the male *Protoceras* is shown in Plate II, and that of *Dinoceras* in the text below.

1.

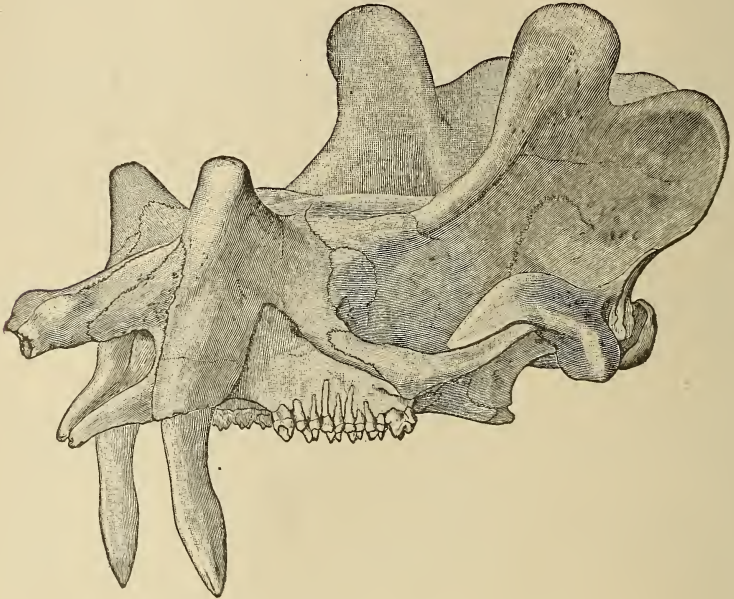

FIGURE 1.—Skull of *Dinoceras mirabile*, Marsh; type; seen from the side. One-seventh natural size. Eocene.

It is a noteworthy fact, that in still another order of ungulate mammals, the *Perissodactyla*, horn-cores in pairs early made their appearance, although none are known in the recent forms. One of the earliest instances is seen in the genus *Coloniceras* from the middle Eocene, which had rudimentary protuberances upon its nasal bones, as represented below, in figure 2. The gigantic *Brontotheridæ* of the lower Miocene all had prominent horn-cores on the maxillary bones, somewhat like those of the male *Protoceras*. One of the most unexpected examples, however, in this order, appears in the Miocene genus *Diceratherium*, the type specimen of which is shown in figure 3. This animal, although a true rhinoceros, had a pair of horn-cores on the nasal bones, while all other rhinoceroses, living and extinct, are either without horns or have them on the median line. In short, horns in pairs are unknown in existing mammals, except in the artiodactyles, an order of later development, but now the dominant group of ungulate mammals.

The Male Skull.

The skull of the male *Protoceras*, in addition to the marked characters above mentioned, has others of equal interest, if not of still greater taxonomic value.* The general appearance of the adult male skull is well shown in Plate II, accompanying the present article, and the special anatomical characters are represented more clearly in the different views on Plates III, IV, V, and VI.

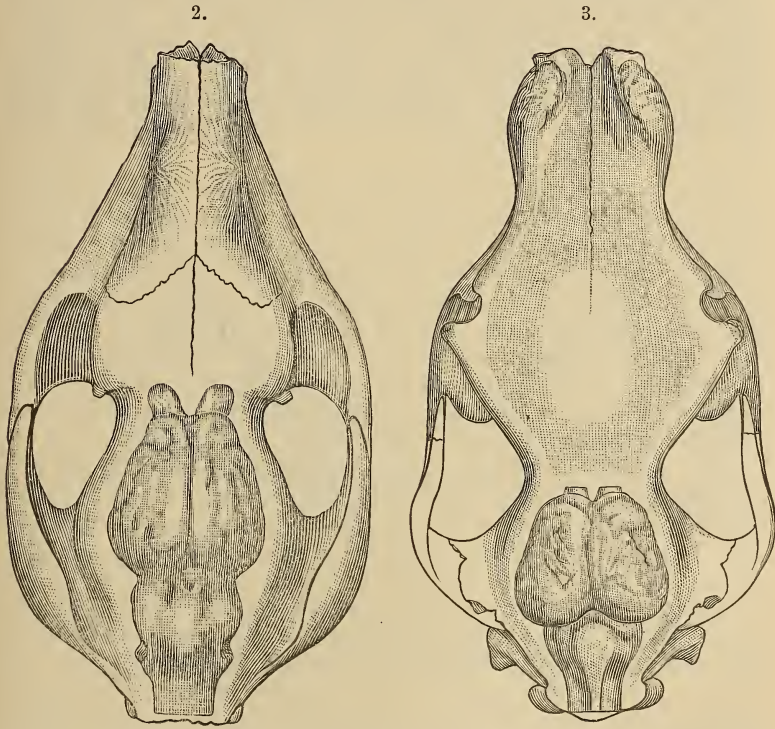

FIGURE 2.—Skull of *Colonoceras agrestis*, Marsh; type, with brain cast; seen from above. About one-half natural size. Eocene.

FIGURE 3.—Skull of *Diceratherium advenum*, Marsh; type, with brain cast; seen from above. One-sixth natural size. Miocene.

Aside from the various horn-cores and protuberances upon the skull, the next most notable feature is the very large, open nasal cavity, a character which pertains to both sexes, and to the entire family of the *Protoceratidæ*. This peculiar feature is of even more importance than the horn-cores, judging from its functional significance, and its rarity in more recent forms of artiodactyles. It indicates clearly in the living animal a

* Osborn and Wortman, Bulletin, Amer. Mus. Nat. Hist., vol. iv, p. 351, 1892. See also Scott, Jour. Morph., vol. xi, p. 303, 1895.

long flexible nose, if not a true proboscis. The only existing ruminant thus equipped, known to the writer, is the rare Saiga antelope (*Saiga Tartarica*, Gray) from the steppes of Siberia. A comparison of a *Protoceras* skull with that of the Saiga antelope plainly indicates, in the nasal region, an identity of function doubtless accompanied by a similar nasal appendage, and it is of interest to find such evidence of this feature in a representative from the Miocene of North America.

The general form of the male skull of *Protoceras* is long and narrow, with the facial portion much produced. The prominent horn-cores, however, serve to obscure its real shape, which is more apparent in the female skull. Seen from the side, as in Plate III, it appears unusually low, with the orbit well behind. Its greatest width is in the posterior region, as shown in Plates V and VI.

The premaxillaries are small and edentulous. Their anterior extremities are depressed, and more or less expanded transversely, as in typical ruminants. The outer suture between the premaxillary and maxillary is short, and persistent even in adults, as indicated in Plates II and III. Seen from below, the premaxillaries form together the palatal surface in front of the maxillaries, each sending backward a narrow process which is inserted between the divergent maxillary plates. The anterior palatine, or incisive, foramina are situated on the sutures separating the two bones, as represented in Plate V.

The maxillary bones are greatly developed, being much the largest elements of the skull, as is well shown in Plate II. The anterior extremity supports the large descending canine tusk, and is hollowed out to contain its base. The high anterior horn-cores are formed entirely of the maxillary bones, which are greatly strengthened to support them. These horn-cores are more or less recurved, and in the type species, their summits are triangular in outline, as seen in Plates II and III, and in the cut below, figure 4. In a new species, *Protoceras nasutus*, the summits of the maxillary horn-cores are oval in section, as shown in cut 5. Another characteristic feature of the genus *Protoceras*, which is seen in both sexes, is a strong lateral ridge extending nearly horizontally across the outer face of the maxillary bone, and continuing backward to the orbit. It is also present in the other members of this family. In the male skull here described, this ridge begins near the base of the maxillary horn-core, and, expanding into a prominent tubercle, just above the antorbital foramen, continues backward by an upward curve, and passes into the ridge of the malar bone extending beneath the orbit. In both sexes, the anterior portion of this lateral ridge, with its characteristic tubercle, forms the lower border of a deep, well-marked

depression, which probably contained a gland. In Plate II, this cavity is well shown behind the maxillary horn-cores, just below the point where the superior border of the skull is lowest.

The nasal bones join the maxillaries above, and complete the posterior border of the large narial opening. They are of moderate length on the median line, and their free anterior extremities are quite short. These bones are much expanded transversely, and at their widest part articulate with the lacrymals. All the sutures surrounding the nasals are distinct, and this is true, also, of their median suture. Their upper surface is convex, both transversely and longitudinally, and is marked by two deep grooves, which lead backward to the supra-orbital foramina in the parietals, as shown in Plate IV.

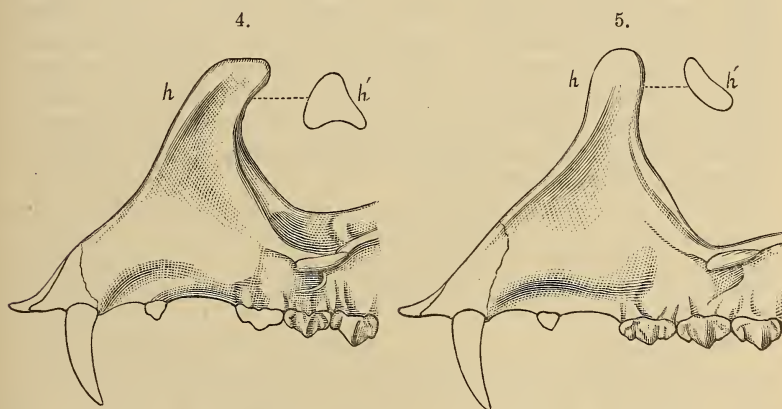

FIGURE 4.—Front of skull of *Protoceras celer*, Marsh; seen from the left side.

FIGURE 5.—Front of skull of *Protoceras nasutus*, Marsh; seen from the left.

Both are male skulls, and drawn one-half natural size. Miocene.

h, maxillary horn-core; *h'*, section of same.

The frontals, which bound the nasals behind, are large massive bones, much wider than long. The suture which unites the two frontals is distinct, and cuts the naso-frontal suture nearly at right angles. At the lateral junction of the frontal and nasal, there is on each side a low tuberosity, resembling a diminutive horn-core, and these form the third pair of elevations on the skull. At the postero-external angle of the frontals, above the orbits, another pair of much larger protuberances is seen, and the summits of these are widely expanded transversely, as shown in Plate IV. The upper surface of the frontals is rugose, and the deep grooves already mentioned are characteristic features.

The parietal bones are much smaller than the frontals, and are separated from them by a distinct sigmoid suture. These bones support the posterior pair of horn-cores, as shown in Plate IV. The general form and position of these elevations on the male *Protoceras* skull are represented in the accompanying plates, but they differ in each species. Behind these horn-cores, there is a low sagittal crest separating the deep temporal fossæ. Back of the parietals is the short supra-occipital, which forms a weak lambdoidal crest bounding the temporal fossæ behind.

The inferior portion of each fossa is formed by the squamosal, which covers the lower half of the brain case, and joins the parietal above by a distinct suture, as shown in Plate III. The squamosal sends forward a short zygomatic branch, which fits into a notch in the posterior part of the malar. There is a distinct postglenoid process. The tympanic bone is not dilated into a definite bulla, but below the auditory meatus forms a short descending process. The periotic is behind the tympanic, separated from it above by the post-tympanic process of the squamosal, and below by an open suture. It is wedged in between the latter bone and the strong and elongate paroccipital process of the exoccipital.

The orbit is closed behind by a descending process from the frontal, which meets the upper branch of the malar. Its lower border is bounded by the malar, which in front joins the lachrymal above and the maxillary below, as shown in Plates II and III.

The lachrymal is bounded in front by the maxillary, above by the nasal and frontal, and below by the malar and maxillary. The lachrymal foramina are two in number, well within the orbital border. The orbits are large, suboval in outline, and widely separated from each other. Their posterior position is a characteristic feature of the genus *Protoceras*.

The Base of the Skull.

The lower surface of the male *Protoceras* skull is represented in Plate V. The narrow occiput, surmounted by the supra-occipital, is a noteworthy character. The widely expanding orbits greatly increase the width of the skull in this region, and from here forward, its wedge-like shape is a striking feature. The large foramen magnum and the narrow diverging occipital condyles are well seen in this view. The basioccipital and the basisphenoid bones are firmly coössified, the suture between them being indistinct. In front of the latter bone is the parasphenoid, separated from it by a well-marked suture, and passing forward above the vomers, which are here distinct. The pterygoids are attached to the posterior border of the palatines, and above to the alisphenoids. There is no distinct alisphenoid canal.

The palatine bones are narrow, and bound in front the posterior nares, which extend forward to near the middle of the penultimate molars. The maxillary plates form the roof of the palate forward to the premaxillaries. At their narrowest portion, they are deeply grooved for the approaches of the palato-maxillary foramina, which are situated somewhat in advance of the second premolars. The maxillary plates are separated in front along the median line, to receive the posterior branches of the premaxillaries, and on the suture between the two elements, the anterior palatine foramina are in their usual position. The turbinal bones were apparently quite small.

The Lower Jaw.

The lower jaw is well represented in Plate II. It is long and slender, especially in front, thus corresponding to the skull. The condyle is broad and strongly convex above. The coronoid process is very short, and its summit is but little higher than the condyle. The angle is rounded and well developed. The ramus expands downward and is thickened beneath the molar teeth, and has a sharp upper edge along the diastema between the first and second premolars. It again extends downward at the symphysis, becoming more robust to support the front teeth.

The Dentition.

The dentition of *Protoceras* is of the early ruminant type, as shown by the short-crowned, selenodont molar series. The dental formula is as follows:

$$\text{Incisors } \frac{0}{3}, \text{ Canines } \frac{1}{1}, \text{ Premolars } \frac{4}{4}, \text{ Molars } \frac{3}{3}.$$

In the male skull, the upper canines are well developed, as shown in Plate II. They are compressed and somewhat trihedral in transverse section, and in life formed efficient weapons of warfare. The first upper premolars, a short distance behind, are small compressed teeth, each with two roots; and after a still longer diastema, the second premolars begin the continuous series. The second and third upper premolars each have a large outer cusp and an inner cingulum, while the fourth has a distinct inner crescent, as shown in Plate V, which also represents faithfully the superior molars. These have all short crowns and the double crescents of true selenodont dentition, with a well-developed inner basal ridge on each. The accurate drawings of the accompanying plates render unnecessary a detailed description of these teeth and most of the others here figured. This is true, also, of various minor points in the structure of the skull.

The teeth of the lower jaw of *Protoceras* are indicated in Plate II, and the full series is shown. The three incisors are directed well forward, and diminish in size from the first to the third. The still smaller canine is situated close to the last incisor, and is similar in form. A long diastema follows, and gives the upper canine freedom of motion. The first premolar is somewhat similar to the corresponding one above, but is larger and directed more forward. A still longer interval separates the first and second lower premolars, the latter beginning the continuous molar series. The second premolar has the crown much compressed, while the third and fourth are triangular in form. The three true molars have the usual crescents corresponding to those above, but no inner cingulum.

The upper molar teeth of the female skull are shown in figure 7, below, which represents the type of the genus. On Plate VI, figure 2, the upper dentition of *Protoceras comptus* is represented, the type specimen figured being the skull of a female not yet adult.* The last three deciduous teeth are here still in use, the first and second true molars are in position, while the last had not yet come into place.

The Brain.

The brain in *Protoceras* was of good size, not diminutive as in the early ungulates. It was, moreover, well convoluted for a Miocene mammal, and forms an interesting addition to our knowledge of the brain development in Tertiary *Mammalia*.

The natural brain cast figured in Plate VII, figures 3 and 4, is from an adult female skull, and represents accurately the brain cavity of this individual, except the small space occupied by the olfactory lobes. The latter were well developed.

The Female Skull.

The type species of the genus *Protoceras*, as already stated, was the skull of a female, and it may be well to repeat here its essential features as given in the original description already cited. In figures 6 and 7 below, most of the main characters of this type specimen are represented.

“In general form and proportions, this skull is of the ruminant type. Its most striking feature is a pair of small horncores, situated, not on the frontals, but on the parietals, immediately behind the frontal suture. These prominences were thus placed directly over the cerebral hemispheres of the brain.

* This Journal, vol. xlviii, p. 93, July, 1894.

“The frontal bones are very rugose on their upper surface, and this rugosity extends backward on the parietals, and to the summit of the horn-cores, as well as between the latter, and along the wide sagittal crest. The horn-cores are well separated from each other, and point upward, outward, and backward, overhanging somewhat the temporal fossæ. They are conical in form, with obtuse summits.

“Between the orbits, the frontals are depressed, and marked by two deep grooves leading backward to the supra-orbital foramina. Behind these, halfway to the horn-cores, is a median prominence resembling in shape the corresponding elevation on the skull of the male giraffe. The brain cavity is unusually large for a Miocene mammal. The occiput is very narrow, indicating a small cerebellum, and the occipital crest is weak. The occipital surface slopes backward.

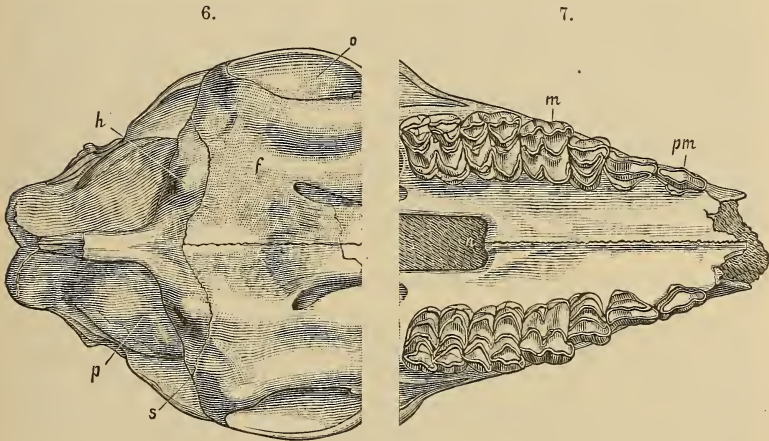

FIGURE 6.—Back of female skull of *Protoceras celer*; type; seen from above.
 FIGURE 7.—Front of same skull; seen from below.

Both figures are one-half natural size. Miocene.

f, frontal; *h*, horn-core; *m*, first molar; *n*, posterior nares; *o*, orbit; *p*, parietal; *pm*, second premolar; *s*, suture between frontal and parietal.

“The facial region of the skull is narrow and elongate. On the outer surface of the maxillary, just above the antorbital foramen, there is a deep depression, which probably contained a gland. The usual ruminant fossa in front of the orbit appears to be wanting. The orbit is large, and completely closed behind by a strong bar of bone.

“The dentition preserved is selenodont and brachyodont, with only three premolars and three molars.* The first premolar is much compressed transversely, and has but a slight inner lobe. The second premolar is triangular in outline, the inner lobe being much more developed. The last premolar has this lobe expanded into a strong cusp, and the crown thus becomes broader than long. The true molars have two inner cusps, each with a basal ridge. The outer crescents have a median vertical ridge. The enamel of the molar series is more or less rugose. There was a wide diastema in front of the premolars.

“The posterior nares are situated far forward, the anterior border being opposite to the posterior cusp of the second true molar. The glenoid facet is large and convex, but the postglenoid process is quite small. The paroccipital processes were well developed, but there were apparently no auditory bullæ.”

A number of other female skulls, some of them in excellent preservation, have since been obtained from the same region in which the type was found, and a study of these makes clear the main points of their structure. It is not quite certain to which of the three species of *Protoceras* now known some of these skulls should be referred, but further investigation will doubtless determine this point, as the present material in the Yale Museum is apparently sufficient for this purpose.

The Skull of Calops.

The small artiodactyle described by the writer in 1894, under the name *Calops cristatus*, is from essentially the same geological horizon in South Dakota in which *Protoceras* was found. As stated in the first description, *Calops* possesses characters indicating a near ally of *Protoceras*, and as the resemblance has proved even closer in more perfect specimens since discovered, denoting that the two genera belong to the same family, it may be well to quote here the main points of the original description.†

“The type specimen is a skull in fair preservation, indicating a fully adult animal, which when alive was about half as large as a goat. In its general form and in most of its characters, this skull agrees so closely with the type of *Protoceras* as to suggest at once some affinity between the two. The dentition preserved in the premolar and molar series is essentially the same. The high maxillary plates joining the short, pointed nasals; the deep lachrymal fossa; and the posterior orbit

* More perfect specimens since discovered prove that there were four premolars, the first being absent in the type.

† This Journal, vol. xlviii, p. 94, July, 1894.

strongly closed behind, all suggest an ally of *Protoceras*, but the parietal ridges are here elevated into distinct crests, and are without horns.

“This skull when complete was about six inches in length. The distance from the front of the nasals to the junction of the parietal crests is about four inches and a half. The space occupied by the last three premolars and the true molars is about two and one-half inches.”

In a later notice, a second more perfect specimen from the same horizon was described,* the main points stated being as follows:

“The brain was comparatively well developed, and an unusually large part of the cerebral lobes was covered by the parietals. The frontal region of the skull between the orbits was more or less concave. The antorbital depressions extend well forward. There is a diastema between the upper canine and the first premolar, and between the first and second premolars. The canines above and below are small. The first lower premolar appears to be wanting. The second and third premolars have secant crowns, much elongated fore and aft. The postglenoid process is quite small, but the paroccipital is large and robust. The lower jaw has a very short coronoid process, and the condyle is sessile. The angle of the jaw is well rounded and somewhat dependent.”

This second specimen proves to be distinct from the type, and is here recorded as a new species, *Calops consors*. The skull, which is in good preservation, is represented on Plate VII, figures 1 and 2. These two views exhibit the main features of the skull in the genus *Calops*. The most striking difference between this specimen and the type is the position of the orbit, which in the latter is entirely behind the molar series, as in *Protoceras*, while in the specimen here figured, as shown in Plate VII, nearly half the orbit is in front of the posterior end of this series.

The Dentition of Calops.

The teeth of *Calops* correspond essentially with those of *Protoceras*, being of the same early ruminant type, with the characteristic, short-crowned, selenodont molar series, and apparently the same dental formula. In the female skull represented on Plate VII, figure 1, most of the teeth are seen in position. There were no upper incisors. The canine was of moderate size, and placed well back of the premaxillary suture. The first premolar is small, with a compressed crown and two roots, and is situated somewhat behind the middle of the

* This Journal, vol. xlviii, p. 273, September, 1894.

interval between the canine and second premolar, as shown in the figure cited. The remaining upper premolars correspond closely with those of *Protoceras* in form, and this is true, also, of the molars. The lower incisors of *Calops* are small and procumbent. The canine also was small, and probably similar in form to the incisors. The first lower premolar is caniniform in shape, with a single root, and a sharp compressed crown, which came nearly in apposition to the superior canine. The remaining lower premolars and molars agree closely except in size with those of *Protoceras*.

The remains of *Calops* now known all appear to have pertained to females, and this naturally suggests the question—what the male skull was like, and especially whether it was provided with horns. The probabilities at present are in favor of the latter view, but it must be left to future discoveries to settle that point.

All the known remains of *Protoceras* and *Calops* are from the upper Miocene of South Dakota. The horizon, which is a definite one, has been appropriately called by Dr. Wortman the *Protoceras* beds. They appear to be identical with the series in Oregon which the writer had previously named the Miohippus beds, as that genus and several others are common to both regions.

Yale University, New Haven, Conn., July 24, 1897.

EXPLANATION OF PLATES.

PLATE II.

Male skull, with lower jaw, of *Protoceras celer*, Marsh; oblique side view. Three-fourths natural size.

PLATE III.

The same skull; seen from the left side. Three-fourths natural size.

PLATE IV.

The same skull; seen from above. Three-fourths natural size.

PLATE V.

The same skull; seen from below. Three-fourths natural size.

PLATE VI.

FIGURE 1.—The same skull; seen from in front.

FIGURE 2.—Front of skull of *Protoceras comptus*, Marsh; seen from below young female, showing deciduous dentition.

Both figures are three-fourths natural size.

PLATE VII.

FIGURE 1.—Skull, with lower jaw, of *Calops consors*, Marsh; seen from the left.

FIGURE 2.—The same skull; seen from above.

FIGURE 3.—Natural brain cast of *Protoceras celer*; female; side view.

FIGURE 4.—The same; seen from above.

The figures are all one-half natural size.

[To be continued.]

ART. XX. — *The Theory of Singing Flames*; by H. V. GILL, S. J.

I.

THE phenomenon of a jet of gas burning inside an open tube, emitting a musical note, is one of those facts which, although known for very many years and although much written about, have never been fully explained. It is not our intention to go into historical details on the subject, but a glance at the chief explanations which have been proposed will be interesting. De la Rive supposed the sound to be due to a periodic condensation of the water vapor produced in the combustion of hydrogen gas. Faraday showed this theory to be false by the fact that he obtained a musical note by means of another gas which does not form water as a product of combustion. Faraday explained the sound as being produced by successive explosions of quantities of an explosive mixture of gas and air which succeed each other at certain intervals. Tyndall accepted this explanation. Another theory which has been proposed is that the sound is produced by vibrations maintained by heat, the heat being communicated periodically to the mass of air confined in the sounding tube, at a place where in the course of vibration the pressure changes. This explanation, although it takes into consideration the extinction of the flame at periodic intervals by the changes of pressure, is not satisfying, and indeed this very intermittent character of the flame presents in this theory certain serious difficulties.

Sondhauss performed a series of experiments in which he made use of a flame of hydrogen issuing from a gas-generating flask. His chief conclusion was that the condition of the column of gas in the supply-tube had an important influence on the phenomenon; for example, if the supply-tube be plugged near the jet with some wool the flame will not sing, though in appearance it is the same as a flame that will sing. This result is a proof that it is impossible to explain the singing by considering merely its effect in heating the air, as in the case of a wire gauze which has been heated. Rijke was able to produce a continuous musical note by means of a wire gauze placed in a tube and kept heated by means of a strong electric current. Now if the note produced by a gas flame were owing to the same cause, the flame, even when the supply-tube was plugged, ought to produce a note if placed at the same position as was the hot gauze when it was sounding, but no such result is observed even when the tube is narrow.

We have performed many experiments to verify the conclusions of Sondhauss, but we did not make use of a gas-generating flask to produce the gas. We employed ordinary coal gas, which passed into a flask* which was provided with two other tubes (fig. 1), one being in connection with the singing flame; the other had one extremity below the level of some water in the flask, the other end being open to the air, thus providing a means of measuring the pressure in the gas. With this arrangement we were able to obtain all the conditions of a gas-generating flask, with the additional advantage that we could regulate the size of the flame, etc., with perfect facility. It is evident that with a flame proceeding from a flask in which hydrogen is generated in the ordinary manner, it is almost impossible to regulate the gas supply with any exactness. All our experiments tended to show that the influence of the supply-tube came not from its length, but from the facility with which it allowed the gas to pass to the flame. For with the same supply-tube we were able to obtain any

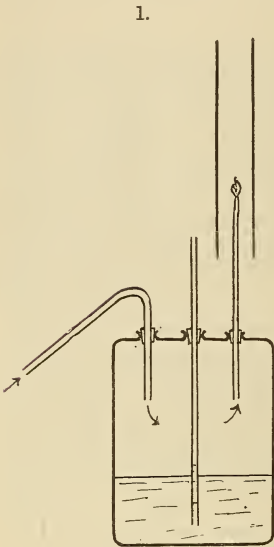

note, either high or low, which we desired, by modifying the size of the flame, its position in the tube, and the length of the tube in which it sang.

In this paper we shall, we think, make it clear that the cause which plays the important part in the production of a musical note by the flame, is one whose effect has not been taken into account by those who have examined this question.

A brief review of the principal facts hitherto observed will be useful to us in what follows:

1st. The note produced depends on the length of the tube inside which the flame sings, on the size of the flame, and on its position within the tube.

2d. The notes are those proper to the tube, account being taken of the temperature of the air inside it.

3d. The flame must be smaller when it begins than when it is singing well.

4th. The spontaneous commencement does not seem to be an essential part of the phenomenon.

* There is no advantage gained from this arrangement in producing the singing flame. The supply-tube may be connected directly with the gas main of the house.

5th. When the flame is of such a size, and placed at such a position that it is on the point of beginning to sing, it may be made to begin by sounding the note proper to the tube; a sudden noise such as the clapping of the hands will sometimes suffice.

6th. The singing may be made to cease by closing one end of the tube, and sometimes by a sudden noise.

7th. Viewed in a rotating mirror the image is composed of a series of tongues, each tongue being separated from the others by a dark space.

8th. When the flame is too large to begin easily, it will respond to the note proper to the tube, but will only sound while the external note is sounding.

9th. The flame becomes blue and somewhat longer when it sings.

10th. Less gas is used when the flame sings than when it remains silent.

11th. If the flame be too small it will be extinguished in a few seconds by the violence of the action.

These are the chief facts which have been recounted by Tyndall and others; there are other facts known which may be looked on as deductions from those enumerated.

In the explanation we propose it will be seen that the theory of explosions, which is admitted by some even at the present time, is not the correct one. All the facts we rely on have been proved by actual experiment, and we make no hypothesis which has not experimental as well as theoretical corroboration.

As the spontaneous commencement is not an essential part of the phenomenon, we shall first examine the flame in the actual state of sounding, and shall then show how it begins.

A consideration of the conditions of pressure of the column of air in a sounding tube is the first step in our explanation.

When a tube, open at both ends, emits a musical note, the column of air divides itself up into nodes and loops or ventral segments. The position of the nodes depends on the note emitted, i. e., whether the tube emits the fundamental note, its octave, etc. At a node there is a considerable variation of the pressure, produced by the longitudinal vibration of the column of air. The pressure varies from its maximum during a condensation to its minimum during a rarefaction; these two conditions occurring in each complete vibration. Various methods are in use for demonstrating this fact, the best known being the manometric flames of Koenig. When such a flame is placed at a node, and its image observed in a rotating mirror, a band of light is seen from which arises a series of tongues, separated by dark spaces, each tongue corresponding to a condensation and each dark space to a rarefaction. Sometimes the

violence of these changes of pressure is so great that it extinguishes the flame altogether.

Though this method shows us that there is a considerable change of pressure, it does not give any numerical measurement. Such measurements have been made by Kundt and others. Kundt employed a water manometer for this purpose. As the changes of pressure follow each other very rapidly it is clear that an ordinary manometer would be useless, and hence he used one which, by means of a valve, could only be acted upon by changes of pressure of a given sign. With such an apparatus he found that, at a node of an open pipe sounding loudly, the increase of pressure during a condensation was equivalent to that exerted by a column of water about 15^{cm} high, and a diminution of equal amount during a rarefaction. Others have found lower values.

We have next to examine another pressure which comes into play in the case of the singing flame, one which has been altogether neglected by those who have proposed explanations of this phenomenon, but which we shall show to be an essential element in the production of the musical note.

The pressure of the gas which produces a flame of suitable size for a singing flame may be easily determined by means of the apparatus we have described. We have only to extinguish the flame which has been singing and close up the aperture. The water will then rise in the pressure-tube. This pressure is one, or two, or even more centimeters of water, according to the note which the flame produced. One might be inclined to think that the pressure under which the gas of the flame issues is always that on the gas supply of the house, but it is easy to show that when the tap which connects the flask to the main pipe is turned so as to let a small quantity of gas issue, that the pressure is proportional to the passage thus modified, the reason being the friction and viscosity of the gas.

The figure will assist us in our explanation: I represents the column of air during a condensation, II during a rarefaction (fig. 2). The flame is situated at a node.

We shall suppose the maximum pressure of either sign to be 5^{cm} of water, since a singing flame does not produce a very loud note, and will take 2^{cm} as the pressure on the gas. Here is roughly what happens when the flame sings:

During a condensation the air is being compressed in the direction of the small arrows with a pressure represented by 5. As the burner of the singing flame is not in communication with the air in the tube except at the small aperture from which the gas issues, this pressure acts in the direction A on the gas. But the gas is issuing from this aperture under a pressure 2 in the direction G. Therefore the resultant of

these is evidently a pressure $(5-2)=3$ acting on the gas in the direction R. This pressure forces the gas back some little distance into the gas pipe, and thus the flame is either made very small, or forced back into the burner with the gas, or extinguished altogether. But this state of things only lasts a small fraction of a second. The condensation changes into

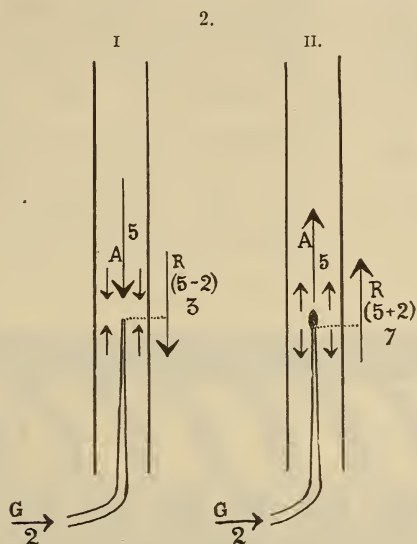

a rarefaction, and the air expands in the direction of the small arrows (II); when the pressure is taken off the gas it rushes forth. By the same reasoning as before we see the resultant pressure is $(5+2)=7$, and that the gas issues forth under this pressure. This pressure, so much greater than the normal gas pressure, causes the gas to escape with great rapidity, the flame lights up again with a slight shock (as one remarks when he lights a gas jet), this shock gives an additional impulse to the expanding air, but again comes the condensation, the flame is again extinguished and so on. Thus we see how the note is kept sounding, a very small periodic impulse being sufficient to keep a note sounding once it has begun.

There is a point to be noted. We said the gas issued forth under a pressure of 7, but it is evident that the gas will come out as soon as the rarefaction is so far developed that the pressure of the air is a little less than 3. From this it is clear that the gas issues forth under a pressure considerably greater than its normal pressure, and that the lighting up of the flame comes at such an instant that it assists the expansion during the rarefaction.

This explanation will be found to account for all the facts which have been observed regarding the singing flame. From it we see that the chief cause to be taken into account is the pressure on the gas, although the flame also plays its part.

The following facts prove the correctness of this explanation.

We stated that the gas was forced back into the burner during a condensation, and that it may happen that the flame is forced back with it. With an aperture of such a size (0.5^{mm} in diameter) as is usually employed no such result could be observed. With a glass tube drawn to a point having an aperture of about 2^{mm} diameter, singing inside a tube 70^{cm} long by 2.5^{cm} in diameter, we noticed clearly that this result actually took place. The image of this flame as seen in the rotating mirror was like that roughly represented in fig. 3.

3.

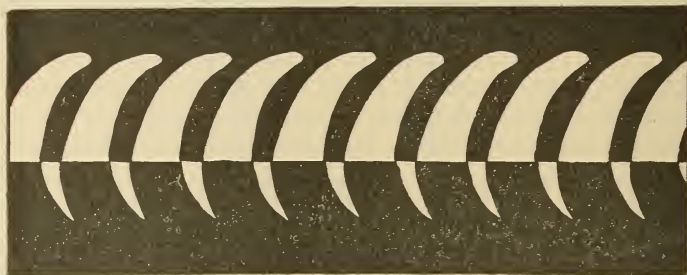

This experiment is rather difficult to make, and the note only continues for a short time owing to the size of the aperture.

The following experiment shows the same thing in a more simple manner. As we have seen, the rapid increase of pressure during a condensation in the sounding-tube produces a downward compression on the gas. It ought, therefore, to be possible to detect this by means of a manometric flame. Fig. 4 explains itself.

When the manometric flame is observed in a rotating mirror the ordinary appearance of a Koenig flame is seen, as is represented in the lower part of fig. 5. In this figure the tongues are somewhat exaggerated in distinctness.

We can use this same arrangement for another interesting experiment. From what we have seen it is clear that the tongues of the image of the manometric flame ought to coincide with the dark spaces of the image of the singing flame, if both images could be perfectly superposed. Since the little shock on the gas is practically transmitted instantaneously throughout the

gas near the jet, the following experiment is of value. The flames, as in fig. 4, were arranged so as to be as near as possible to each other, the point of the manometric flame just reaching the base of the other. The axis of the rotating mirror was in the same plane as these two flames. On viewing the two images in the mirror, an eye placed in the plane of the flames sees the images as in fig. 5.

The top row represents the image of the singing flame. It will be seen that what we had anticipated actually takes place. The appearance of the flame also supports our theory. When gas issues under pressure the flame drags in the air which surrounds it, thus presenting the aspect of the flame of a Bunsen burner.

The following facts show the importance of the pressure of the gas in the phenomenon. We have seen that if the supply pipe be plugged near the jet that the flame will not sing. This is clearly because the reaction between the two pressures is interfered with. Tyndall remarks that, with a tube 15 to 20^{cm} long, he was able to obtain, by varying the size of the flame and its position in the tube,

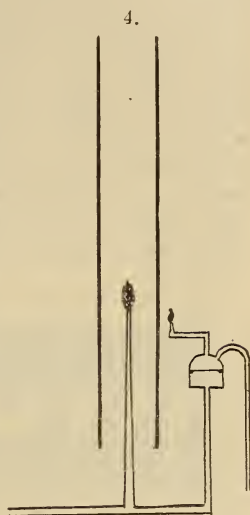

5.

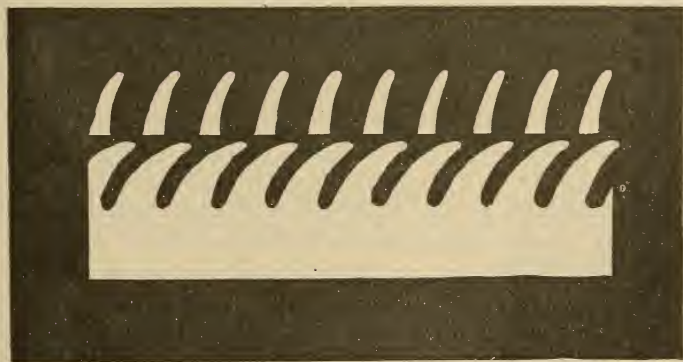

a series of notes represented by the numbers 1, 2, 3, 4, 5. He says also that this experiment shows why it happened that various experimentalists, who did not change the position and size of the flame, had difficulty in obtaining desired notes in their public lectures. We see clearly from our theory why

this is so, for the size of the flame depends on the pressure of the gas which feeds it. We see also why a gas-generating apparatus is disadvantageous, because, as we have before remarked, it is impossible to regulate the gas pressure with sufficient exactness. With the flask we have above described, we were able to see that the notes produced depended in great measure on the pressure, and that also the intensity of the sound depended on the same cause. We also noticed that, immediately on the note beginning to sing, the water rose a few mm. in the pressure tube, thus showing that less gas was used when the gas was singing than when silent, a fact which was also noticed by Count Schaffgotsch, from a different experiment.

Thus far we have considered a flame singing under the most favorable conditions. Often, however, if the size of the flame (i. e., the pressure of the gas) and its position in the tube be carefully regulated, the note produced, though continuous, is faint, and does not develop into a full, loud sound. The image of the flame in this case does not present a series of distinct tongues as in the former case, but resembles that of a manometric flame. On considering what we have hitherto said, this case presents no difficulty. It is only necessary to remark that the pressure of the gas and its position being such, the reactions just described are not sufficiently marked to produce the full result. If the flame be distant from the node to which its size is well adapted, it is clear, since the changes of pressure are less intense the farther we go from the node, that the flame cannot sing as it would do if under more favorable conditions. In the same way is to be explained the fact that the note is not always that which would require a node at that part of the tube where the flame is placed, for it may happen that the size of the flame corresponds better to the period of a note which has a node farther from it, which note it will reinforce rather than the one which has a node nearer to it. So also is easily explained why the flame may emit two notes simultaneously—i. e., if it be placed so as to be near both nodes. It may be said that the limit of pressure required for a given note is fairly wide.

We think we have thus sufficiently shown the importance of the pressure on the gas in maintaining the sound. We have now to show how the flame begins to sing. The flame may begin to sing without any apparent external cause, or may be put into action by an external cause. We hope to show these two cases may be reduced to the latter. Tyndall, in his usual graphic way, describes in his "Heat" how a flame, too large to sing continuously, will respond to the note proper to the tube inside which it is placed, if this note

be sounded by a siren or other means. He says that this is an example of the propagation of sound, by vibrations through the air, and its reception by a body extremely sensitive to such influences. If the flame is smaller, it continues singing once it has begun to respond. That is to say, the flame takes up the vibrations of the air inside the tube, reacts on them in the way we have described, and thus the sound is strengthened into the continuous note with which we are familiar. If we examine the flame in a rotating mirror before it has begun to sing, we see of course a continuous band of light. Now, if we sound the note of the tube, regarding the flame in the rotating mirror while doing so, we see the image as represented in fig. 6.

6.



From this we see clearly the mutual reaction between the flame and the column of air. If the flame be so small that it is just on the point of beginning to sing of itself, a sudden noise, such as clapping the hands, will cause it to begin. Always, however, the gradual development as shown in fig. 6 takes place. Again, a small flame may be made to sing by blowing gently across the top of the tube, and as before shows the gradual development. These facts are sufficient to show how the pressure due to the vibration of the column of air and the pressure of the gas react on each other. It is scarcely necessary to add that in reality this "gradual development" takes place in a very short interval of time, especially in the case of a small plane inside a short tube.

From what we have seen we are led to the conclusion that, when the flame begins spontaneously, in reality the cause is to be found in some change of pressure taking place in the column of air. If we slowly lessen the flame, before it begins to sing, regarding it as before in the rotating mirror, we notice, at a certain point, that gentle undulations appear on the border of the band of light, which follow the cause of gradual development above described. Is there any such external cause at work? We think we shall be able to show that there is. We have seen that the slight changes of pressure due to a note sounded at some distance from the tube produce changes in the pressure sufficient to cause the flame inside the tube to sing (Schaffgotsch put a small flame into action by the noise caused

by displacing a chair in the room next that in which the flame was placed). We have seen, too, that the slight changes of pressure produced by blowing across the end of the tube were sufficient, even when the flame was not small enough to begin of itself; therefore a lesser cause will suffice when the flame is still smaller. The air inside the tube is at a higher temperature than that of the atmosphere; this causes a current of air to pass upwards through the tube with a velocity which we can calculate.* This current as it passes the edges of the tube produces a faint note. The variations of pressure caused by this note are sufficient to put the flame in action. This conclusion is justified by the following facts:

(a) A flame begins much more easily in a long tube than in a short one, and we know the current due to the temperature of the air is proportional to the length of the tube, so that the note produced in a long tube is more intense than in a short one.

(b) On placing the ear near the lower extremity of a tube 60^{cm} long, inside which a silent flame burns, one hears the note produced by the current of air passing up.

(c) A consideration of the various ways in which a flame may be caused to sing leads to this conclusion.

Although this reaction is the chief one which causes the flame to begin to sing, we must bear in mind that there are innumerable other minor ones which, in certain cases, may play a part. Thus in the case of a very small flame inside a short tube (8.0 or 10.0^{cm}) the expansion of the air near the flame, and accidental changes of the pressure of the gas, may be of importance.

We think we have made it clear that the pressure on the gas plays the important part in this phenomenon, and that a consideration of the reactions we have described will be found to explain the many facts noted in the case of a singing flame, some of which we have alluded to. We look therefore on the chief cause as a mutual reaction between the pressures in the tube and on the gas; the energy necessary to sustain the note being supplied by the pressure on the gas and the action of the flame. We may compare the singing flame to the siren, in which the current of air causes the disk to rotate, the note being produced by the reaction of the disk on the current of air.

* Dr. Everett investigates in his "Natural Philosophy," part II, the conditions for a good draught up a chimney and applies the formula of Torricelli for the efflux of liquids from orifices. This formula for the velocity of the air current is

$$V^2 = \frac{2gha(t-t')}{1+at}$$

in which g =gravity; h =length of chimney (or tube); a =the coefficient of expansion for air; t =the temperature inside the chimney, and t' that of the exterior air.

II.

There is another case of singing flames which we shall briefly explain by a reasoning similar to that we have just employed. If a tube, say 30^{cm} long by 3 or 4^{cm} in diameter, be placed on a piece of wire gauze, the whole 5^{cm} above a Bunsen burner, and if the gas be lighted inside the tube, a high note of great intensity is produced. This experiment was first made by Lissajous, who called it a "whistling flame." As we have never seen any explanation offered, we think the following will be found interesting. We have determined the following facts:

1st. The note depends on the length of the tube and the volume of the flame.

2d. The gauze need not be outside the tube, but if placed inside, the note is also produced.

3d. If the gauze be more than a certain distance below the base of the tube, no note is produced.

4th. The image in a rotating mirror shows periodic disturbances at the base of the flame.

Just as a node is the position most favorable for the singing flame, a loop is that favorable for the whistling flame. There is a loop at the end of an open pipe, and hence the flame sounds when at this position. As every note which an open pipe can produce has a node at the base, we see that each can be produced by the flame at this position, and hence it is that the note is so high and shrill, for, as we shall see, a great number of tones are produced simultaneously.

At a loop, or ventral segment, there is considerable motion of the air, as is shown by placing a small tambourine with some sand on it at a loop; the sand is violently agitated by the air currents due to the vibration. The motion of the air at the extremities is sensible for some distance outside the tube. Mach studied this movement, and found that for a pipe four feet long the amplitude at this point was 4^{mm}.

We can easily calculate the velocity of these air currents if we know the amplitude of vibration and the period of the note. However in the general investigation this will not be necessary. Let us call this velocity x .

We have seen that the draught, or current due to the flame inside the tube, can be calculated from the formula

$$V^2 = \frac{2gha(t-t')}{1+at}$$

For a certain tube we have calculated that the current due to the vibrations was 2 meters per second, the draught 1 meter per second. Let us suppose the velocity of the current due to the vibration is x , that due to the draught y .

As before, let us first consider the flame actually sounding. At the node nearest the base (it is only necessary to consider one of the notes) there are alternately condensations and rarefactions. When the condensation is changing into a rarefaction there is a current of air which issues from the tube; this is the first stage. When the rarefaction is becoming a condensation this current enters the tube. During the first stage the current due to the draught tends to cross the gauze with a velocity y ; but the current due to the vibration is in the opposite direction with a velocity x : therefore at this moment the resultant current has a velocity $x-y$. This current is less than if the flame had been silent, so that a smaller amount of gas enters into the flame. But after a very small fraction of a second the rarefaction at the node changes into a condensation. During this second stage the current due to the vibration goes up the tube and is in the same direction as the draught. Therefore the resultant current has a velocity $x+y$. This current, much more rapid than when the flame was silent, and than that during the first stage, causes a greater quantity of gas and air to enter into the flame than before. This sudden augmentation of the flame gives an impulse to the vibrations already taking place, and thus the note continues.

This explanation is proved by several experiments. We have stated that the gauze may be a certain distance below the base of the tube. We have seen that the vibrations of the air column extend a certain distance outside the end of the tube. Many researches have been made to determine the exact law which this distance follows, but though in individual cases it is easy to determine the amplitude, it is difficult to formulate a general law. It has been determined that this distance depends on the diameter of the tube, and that when the wave length of the note is great in comparison, this distance is somewhat greater than two-thirds the radius of the tube. We have made many experiments with the gauze in various positions, and find that the gauze must be inside the limit assigned by this law, or no note will be produced, which shows that the note depends on these air currents.

A second proof is that the note produced is not pure, but is composed of a number of different ones. We have seen that all the notes of the tube may be produced together and that thus the resultant note is composed of tones proportional to 1, 2, 3, 4, 5. . . . If the gauze be placed at the middle of the tube the note is much higher. We see at once why this must be so if the whistling flame is proper to a loop. For the only tones which have a loop at the middle of an open pipe are those proportional to 2, 4, 6, 8, etc. Therefore since so many of the lower tones are absent the resultant tone is higher than in the former case.

We have made experiments analogous to those described in the case of the singing flame to determine the manner in which the note begins. Our experiments lead to the conclusion that it is the same as in that case, and that the original note caused by the draught is strengthened by the reactions we have detailed. As the arguments used in the case of the singing flame apply with even greater force in the present case, it is not necessary to repeat them.

III.

There is, finally, one other case of a note caused by a flame which we shall consider very briefly. An experiment was suggested to test the theory in which the singing flame is explained as if it were a heated body. If so, a taper flame ought to sing if placed in a favorable position. An ordinary taper flame remains perfectly silent. On dividing up the wick so that the head of the taper stretched over the tube, a note was produced which lasted several minutes. This is merely a case of Rijke's experiment of the heated gauze above alluded to. Rijke's experiment has been explained already, and is easily understood if we consider the action of the pressure and various air currents in a sounding pipe, and bear in mind that the most favorable moment for the air to receive an increase of temperature is when a condensation is changing into a rarefaction. The following passage from a lecture by Lord Rayleigh will make this clear ("Nature," vol. xviii, p. 320, 1878): "Perhaps the easiest way to trace the mode of action is to begin with the case of a simple vibration without a steady current (i. e. the draught). Under these circumstances the whole of the air which comes in contact with the metal in the course of a complete period becomes heated; and after this state of things there is comparatively little further transfer of heat. The effect of superposing a small steady upward current is now easily recognized. At the limit of the inward motion, i. e., at the phase of greatest condensation, a small quantity of air comes in contact with the metal which has not done so before, and is accordingly cool; and the heat communicated to this quantity of air acts in the most favorable manner for the maintenance of the vibration." "Both in Rijke's and Riess's* experiments the variable transfer of heat depends on the motion of vibration, while the effect of the transfer depends upon the variation of pressure. The gauze must therefore be placed where both effects are sensible, i. e. neither near a node nor near a loop." (We have found the same in the case of the

* Riess's experiment consists of a note produced by a current of hot air passing through a cool gauze.

taper flame.) "About a quarter of the length of the tube, from the lower or upper end, as the case may be, appears to be the most favourable position." When the gauze is near the top a slight modification is required, but the theory is essentially the same.

We have, then, three kinds of singing flames; one depending on changes of pressure; another on air currents; a third depending at once on both changes of pressure and on air currents.

In the above paper we have explained the general causes of the phenomenon, but it is evident that in so complex a subject it would be impossible to enter into more explicit details in the limits of a simple article. It is hoped that these ideas will attach a further interest to this old fashioned but interesting experiment.

Louvain.

ART. XXI. — *Electrical Discharges in Air*; by JOHN TROWBRIDGE.

THE flaming discharge from a large accumulator with its nucleus, consisting of a dazzling white spark, is evidently a form of voltaic arc; and I was interested to discover if possible the mechanism, so to speak, of the voltaic arc. Does it follow Ohm's law in respect to resistance, and is there an oscillatory phenomenon? It is well known that electric sparks can be greatly increased in length by interposing a gas flame between the terminals of a Ruhmkorf coil, or by moderately rarifying the air between such terminals. The conditions in the voltaic arc favor a greatly increased length of a disruptive spark between the positive and negative carbons. This can be seen in the photograph of the arc produced by a high tension accumulator; and doubtless the same phenomenon could be observed in the ordinary voltaic arc if it were not so exceedingly brilliant.

I have lately studied the apparent resistance of the voltaic arc in the following manner. In the circuit B, fig. 1, of forty large storage cells, giving 80 volts, was placed a low resistance choking coil, L, or coil of large self-induction. To the carbon terminals, A, between which the voltaic arc was produced, were led the terminals of a condenser, C. The latter was charged by a step-up transformer, T. The oscillatory discharge of the condenser was thus passed through the voltaic arc; and a spark in a gap in the circuit of the condenser was photographed by the aid of a revolving mirror. The photographs gave the

number of oscillations in the circuit containing the arc and the condenser. A curve was then plotted with the number of oscillations as ordinates and the ohmic resistance of the circuit as abscissas. It was thus found that the apparent resistance of the voltaic arc was equivalent, in the case I considered, to a resistance of eight-tenths of an ohm ($\cdot 8$ ohm). It was found, moreover, that an arc one-quarter of an inch long did not present more resistance than one, one-half an inch long. The apparent resistance, therefore, of the voltaic arc does not follow Ohm's law. I am led to believe that the mechanism, so to speak, of the voltaic arc is as follows: A disruptive discharge accompanies a flaming discharge, and serves as a species of pilot spark. A variable difference of potential is necessary to sustain the disruptive discharge; and this variable difference of potential makes itself evident as an apparent change of resistance; the arc shortens or lengthens in obedience to the mechanism of the lamp which is employed.

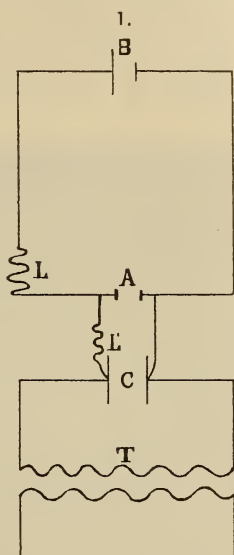

A family resemblance may be said to exist between all forms of electrical discharges in air. Thus in the voltaic arc we have a disruptive discharge combined with a flaming discharge. In general the disruptive spark is oscillatory even in the case where the voltaic arc is produced by a dynamo machine. When we extend our studies to the forms of electrical discharges which are free to a great extent from the flaming discharge, such as the disruptive sparks from electrical machines, Tesla and Thomson transformers and the Planté rheostatic machine, we are struck by their close resemblance to the ordinary forms of lightning discharge. I have lately employed, in connection with five thousand Planté cells, a Planté machine with thirty condenser plates made of glass, one-sixteenth of an inch in thickness, with a coated surface of 15×18 inches. Sparks nine to ten inches long can be very conveniently studied by means of this apparatus, for a close estimate of the difference of potential is possible and the exciting apparatus does not change its sign during the experiments. To the eye each spark seems to be surrounded by a bright radiance or aureole of which it appears to be the nucleus. In order to ascertain whether this radiance was an actual phenomenon, I employed a portrait lens of large aperture, and some of the results are exhibited in the accompanying reproductions, which fail, however, to give the details of the negatives. Fig. 2 is a

photograph of a spark taken with a Euryscope lens, such as is commonly employed for landscape work. This does not show any detail. Figs. 3, 4 and 5 are photographs taken with a Dallmeyer portrait lens, without a diaphragm, and show on the negatives what may be considered an aureole accompanying the spark its entire length. Furthermore, the oscillatory nature of the sparks is shown by forked discharges which

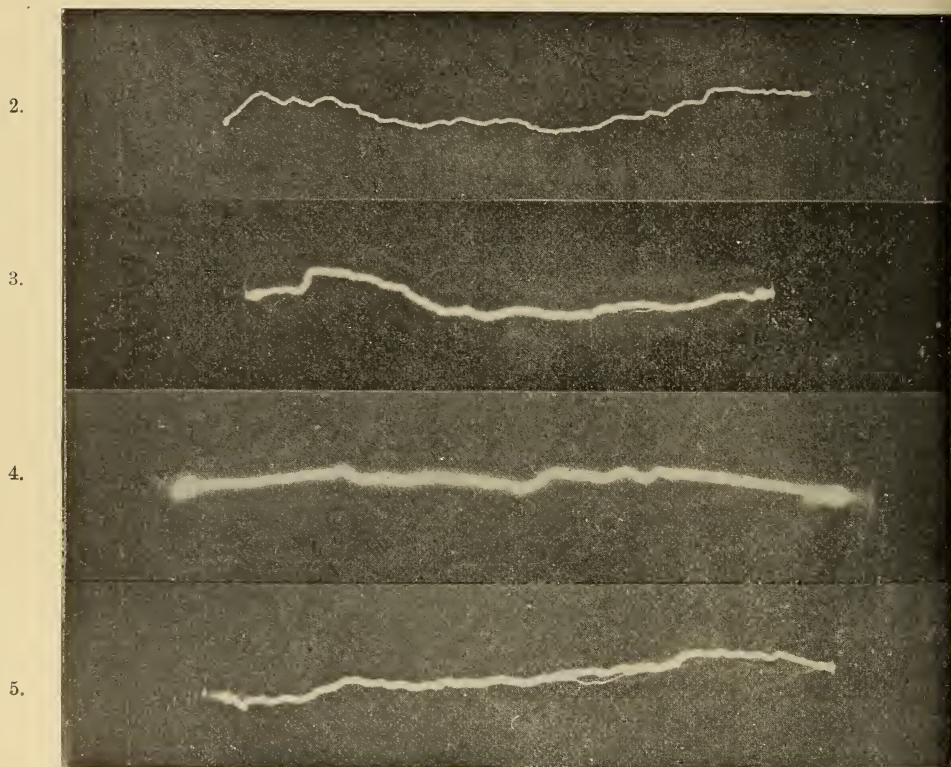

diverge from the main path of the spark and which point in opposite directions on the same spark. If a photograph of lightning could be obtained which would show a similar phenomenon, there could be no doubt of the oscillatory nature of lightning.

Since one can, with a large number of Planté cells in connection with a rheostatic machine, control the sign of the electric charges on the spark terminals, I was interested to test the question whether the eye can detect any direction in electric sparks. One observer, looking through an opening which concealed the spark terminals and only revealed the central portion

of the sparks, noted down his impression of the apparent direction of each spark, while another observer reversed the poles which charged the rheostatic machine. On comparing the notes of the two observers, it was found that there was no agreement in regard to direction. This result was to be expected from the oscillatory nature of the discharges. It may be that in the case of lightning the eye is forcibly impressed by the greater brightness of the positive terminal in the cloud, and the observer concludes that the flash has a unidirectional movement.

When oscillating sparks of the nature represented in figures 2, 3 and 4 are passed through Crookes tubes of the focus tube pattern, it was found that photographs could be taken on plates exposed to the inclined surface of the platinum, both when it was made the anode and when it formed the cathode. No difference in definition could be noticed. There was, however, a great difference in actinic effect. Under the oscillatory nature of the Leyden jar discharge the electrodes become alternately positive and negative. Possibly some of the want of definition noticed in Röntgen photographs, taken even with the aid of electrical machines, may be due to the fact that the oscillatory discharge does not always emanate from the same point on the anode surface. A small anode should therefore give sharper images than one of a large surface.

What is supposed to be a resistance in the case of the voltaic arc, and in the modifications of this arc seen in discharges from high tension transformers, and in powerful electric sparks, and presumably in lightning discharges, is a polarization which produces a variable difference of potential at the spark terminals.

The inconstancy of spark potentials has been shown by Jaumann.* In working with a revolving mirror, it is found that the spark terminals have to be brightened in order to preserve the same spark length. I was interested also to observe the effect of the surrounding medium upon the spark potentials. Platinum terminals in sodium vapor showed the polarizable condition: but there did not appear to be an appreciable change in resistance, apart from this polarization. The same was true when bromine vapor surrounded the spark terminals. In the case of Crookes tubes, it is customary to apply heat if the discharge will not pass through the tube: and some makers provide a connecting receptacle which contains a substance which, on being volatilized, modifies the internal conditions of the tube. This modification is often spoken of as a diminution of resistance of the tube. It should be more properly termed a method of modifying the state of polarization of the electrodes.

Jefferson Physical Laboratory, Harvard University.

* Wied. Annalen, lv, p. 656, 1895.

ART. XXII.—*The Oscillatory discharge of a large Accumulator*; by JOHN TROWBRIDGE.

THE discharge from a large number of Planté cells is characterized by a sibilant flame which, by quickly separating the spark terminals, can be drawn out to a length of several feet. It closely resembles the light produced by passing an electric spark through lycopodium powder. When a photograph of

1.



this flaming discharge is examined, it is seen to have an intensely bright spark as a nucleus. On account of the flaming discharge it is difficult to examine its character by means of a revolving mirror. By employing, however, two spark gaps it seemed possible to ascertain whether the discharge is oscillatory or not.

In my experiments the circuit was made at the instant the revolving mirror was in the position to reflect an image of the discharge of the battery upon a sensitive plate. The photographs obtained in this way showed disruptive discharges superimposed upon a continuous discharge. The latter, however, masked any appearance of an oscillatory discharge. It

was evidently necessary to blow out the flaming discharge in order to see if oscillations followed the pilot discharge. The first experiment was made with 2500 cells arranged in series; and the flaming discharge was much lessened both by the reduction in the number of cells and by a suitable arrangement for blowing it out. On developing the photographs it was found that the discharge was an oscillatory one; for as many as five or six clearly defined oscillations followed the first, or pilot discharge. The number of cells was then doubled; and, although more difficulty was experienced with the flaming discharge, oscillations were again obtained.

On the supposition that each cell of the battery can be regarded as a leaking condenser; and that it is equivalent in capacity to a condenser shunted by a resistance equal to that of the electrolyte, we can treat such a cell as a conducting condenser under the influence, during discharge, of a periodic current. The analysis of this well-known case is as follows.* Let ABC and AEC be two circuits, the circuit ABC being a shunt to the circuit AEC, which contains a condenser E.

Let L be the coefficient of self-induction of ABC, R its resistance, C the capacity of the condenser in the circuit AEC and r the resistance of the wires leading to the plates of the condenser.

Then if i is the current through ABC and x the charge on the plate nearest to A

$$L \frac{di}{dt} + Ri = r \frac{dx}{dt} + \frac{x}{c}.$$

Since each of the quantities is equal to the electromotive force between A and C.

If $i = \cos \rho t$,

$$\text{then } x = \frac{(L^2 \rho^2 + R^2)^{\frac{1}{2}}}{\left(\frac{1}{C^2} + r^2 \rho^2\right)^{\frac{1}{2}}} \sin(\rho t + a)$$

$$\text{where } a = \tan^{-1} \frac{L\rho}{R} + \tan^{-1} \frac{1}{r\rho C}.$$

$$\text{Hence } \frac{dx}{dt} = \frac{\sqrt{L^2 \rho^2 + R^2}}{\frac{1}{C^2 \rho^2} + r^2} \cos(\rho t + a).$$

Thus the maximum current along AEC is to that along ABC as

$$\sqrt{L^2 \rho^2 + R^2} \text{ is to } \sqrt{\frac{1}{C^2 \rho^2} + r^2}.$$

Or if we neglect the resistance r of the leading wires, as

$$\sqrt{L^2 \rho^2 + R^2} : \frac{1}{C\rho}, \text{ or neglecting } L, \text{ as } \frac{R}{\frac{1}{C\rho}}.$$

* See Elements of Electricity and Magnetism, Prof. J. J. Thomson, p. 431.

In the case of one cell of the battery the polarization capacity is undoubtedly very large. C. M. Gordon* finds that the polarization capacity of two surfaces of platinum 0.65cm^2 separated by an interval of 2mm amounts to more than 50 microfarads. The cells of my battery consist of lead plates of about 10cm^2 surface separated by about 6mm . The layer of peroxide of lead undoubtedly gives a large polarization capacity. The resistance of each cell is about one quarter of an ohm. Even with this small value of R , oscillating currents such as my experiments show arise when the battery discharges through air or gases. A large portion of the oscillating currents pass through the condenser circuit, and the electrolyte acts as a semi-insulator. With a very high value of p , no current would pass through the electrolyte and the cells would therefore act like Leyden jars. In the case I am considering the Planté cells evidently act like leaky Leyden jars coupled in series. If C is the apparent capacity of one cell $\frac{C}{n}$ would be the capacity of n cells.

An examination of the photographs of the oscillations produced by 2500 cells, showed an apparent capacity of about 1000 electrostatic units. Five thousand cells gave an apparent capacity of about 500 electrostatic units, as should be the case. The small apparent capacity C results from the leaking of the condenser due to the conduction through the electrolyte.

Since the discharge from an accumulator of a large number of cells is, in general, oscillatory, I am led to the belief that the discharge from any primary battery is also oscillatory, for in all cases we have to deal with capacity and self-induction. It is evident that a galvanometer in circuit with a Geisler tube or a telephone cannot detect the oscillatory discharge, since it is of high period. Moreover when a Geisler tube is lighted by a large battery with no resistance save that of the Geisler tube and the battery in the circuit, and the light is examined in a revolving mirror by the eye, no oscillations or intermittance of light can be perceived on account of the flaming discharge through the rarified gas.

The oscillatory discharge may be said to be the common occurrence of nature in the case of electrical discharges and the one direction discharge the uncommon. This has been expressed by the remark that electricity takes the path of least resistance; this common belief, however, must be modified under certain conditions of resonance. In general nature avoids a unidirectional discharge.

Jefferson Physical Laboratory, Harvard University.

* Wied. Ann., No. 5, 1897, p. 28.

ART. XXIII.—*Jura and Neocomian of Arkansas, Kansas, Oklahoma, New Mexico and Texas*; by JULES MARCOU.

HISTORIC geology, or stratigraphic classification, is a very difficult and at the same time a most important part of the history of our globe. Without exact classification, all becomes confusion, geologic periods are confounded, and we are confronted by the same sort of errors that would occur if some historian were to place the time of Cromwell after the time of Washington.

In all other sciences, like chemistry, physics, anatomy, etc. each new fact can be verified in laboratories, after a period of time relatively short. Not that criticism, and strong and even passionate opposition, are not found in these sciences; we remember well the protest against the experiments made to disprove spontaneous generation. It required much persistency and courage on the part of Pasteur to maintain the truth he had discovered. The chemist Berthelot published in the *Révue Scientifique* some incomplete investigations of the late Claude Bernard, which he found in loose notes after the latter's death, without even taking the polite precaution to make known to Pasteur his intention of attacking his observations on the non-existence of spontaneous generation. Numerous discussions followed at the meetings of the Academy of Science of the French National Institute, until Pasteur, excited by the incessant attacks of two adversaries, bravely turned towards them and said to one, "Savez-vous ce qui vous manque? vous ignorez l'art d'observer;" and to the other, "Et vous, celui de raisonner."*

The controversy against my observations on the geology of Texas, the Indian Territory and New Mexico, has lasted much longer than the opposition made against Pasteur, for it is now forty-four years since I made them and they have been and are still the subject of constant criticism.

In science, discussion must be based on the observation of facts; in geology, these observations must be made on the ground and at the precise locality under discussion. For years the two localities discussed were not only far distant from civilization, but also situated in a part of the country which, on account of hostile Comanches, Kiowas and Apaches, it was impossible to visit without a large military escort. Consequently my contradictors discussed my observations without a practical knowledge of the stratigraphy; and with a want of

* Discours de M. Joseph Bertrand, directeur de l'Académie Française, séance du 28 Janvier, 1897.

the most elementary kind of knowledge of the genus *Gryphæa*, uniting into a single species six or eight entirely distinct species. It was to be hoped that when, in about 1880, Indian Territory and the Tucumcari region were finally opened for settlement and civilization, my opponents would examine the two localities; one called Comet Creek, now in G. County, Oklahoma, and the other Pyramid Mount in the Tucumcari region of New Mexico. But not at all; to this day, Comet Creek has not been visited by any other practical geologist*; and Pyramid Mount of the Tucumcari area was systematically left out of the route of exploration by the three persons who were there, since 1888. The curious part of it is that the section at Pyramid Mount is most complete, without any obscurity by vegetation, practically a bare wall, and unique in the Tucumcari region for its beauty and perfection from a geologic point of view. I shall not imitate the frankness of my friend Pasteur, and contest the capacity of my adversaries as stratigraphists and paleontologists, but I owe it to science to maintain what I consider to be exact and true; and however tired and wearied by years, by my infirmities and the exceptional length of the discussion—lasting almost half a century—I shall continue not only to affirm the correctness of my observations, but also to ask my numerous adversaries to visit Comet Creek and Pyramid Mount, and beg them to publish the sections accompanied by good figures and descriptions of all the fossils they may gather *in situ*. I am happy to remark, that they will have the great privilege and immense advantage of remaining there as long as they please, to observe and collect specimens, while I was enabled, on account of the rapidity of the march of my military escort, to remain at Comet Creek only one hour and at Pyramid Mount only three or four hours.

The question of the existence of the Jura and the Lower Cretaceous (which I call briefly Neocomian) has taken, thanks to the opposition, such great proportions, that one of my opponents said lately: "There are reasons for suspecting that no marine Jurassic formations of Atlantic sedimentation have as yet been discovered north of Argentina (South America) on the present Atlantic slope of the American hemisphere." (Science, vol. iv, No. 103, p. 920.) A clean sweep of the marine American Jura.

Let us review the main localities in the United States, west of the Mississippi River and east of the Rio Grande del Norte.

Arkansas.—For the sake of brevity, and not to burden the

* Lately the locality of Comet Creek has been visited by Mr T. W. Vaughan, who finds the same beds of limestone containing *G. Rameri* (called *G. forniculata*). His description does not differ from the one I have given as far back as 1853. "Outlying areas of the Comanche series"; this Journal, vol. iv, July, 1897.)

reader with too many details, I shall speak only of the Trinity formation, of the locality in Pike County, Arkansas, close to the boundary line of Texas. Mr. Hill, the inventor of the name Trinity formation, has published in the Annual Report of the Geological Survey of Arkansas, for 1888, vol. ii, Mesozoic, two chapters, xii and xiii, in which are described the strata and the fossils, the latter with figures. It is useless to reprint what I have said on each species of fossil; I need only say, that I have shown with accuracy and details, in the American Geologist, Dec., 1889, pp. 357-367, that the whole fauna, without a single exception, is composed of Jurassic fossils, and concluded that instead of being Lower Cretaceous, the strata near Murfreesboro represent in Arkansas and Texas the superior Jura from the Oxfordian upward, including the Purbeck formation.

As an example of carelessness, not to use a stronger word, in quoting a plain paleontological fact, I call the attention of the reader to a quotation of Mr. Hill, at p. 128. In the description of *Ammonites Walcottii*, we read: "It resembles . . . also *Ammonites Yo*, d'Orb. of the Lower Cretaceous." Turning to the great work of the *Paléontologie Française* by d'Orbigny, in order to examine and verify the resemblance of the two Ammonites, I naturally took up the volumes entitled: "Terrain Crétacé." But there is no trace of *Ammonites Yo* in those volumes. As I know the species well and that the form is undoubtedly Jurassic, I took the volumes entitled: "Terrain Jurassique," and there in vol. i, pp. 545-546, is the *Ammonites Yo* with the special location of "Etage Kimmeridgien, Boulogne-sur-Mer." Instead of belonging to the Lower Cretaceous, according to the extraordinary alteration of Mr. Hill, it is an Upper Jura species. Why Mr. Hill took upon himself to change the age of the *Ammonites Yo*, cannot be explained otherwise, than that he wanted to sustain his classification of the Trinity division in the Cretaceous, quoting in his favour the great authority of d'Orbigny. This case shows how unreliable Mr. Hill is, when he writes on paleontology.

Kansas.—As long ago as 1888, I corresponded with Professor F. W. Cragin of Topeka, in regard to a *Cycadoidea* found in Maryland, for the purpose of comparing it with a specimen of the same genus of fossil plant collected in Kansas. On reading Professor Cragin's first two papers on the geology of a part of southern Kansas comprising Barber, Pratt, Kiowa and Comanche counties, south of the Arkansas River, in the upper region of Medicine Lodge River, I thought that the Jura existed there, and wrote so to him. He sent me a small box of specimens, all Cretaceous fossils. After an exchange of a few letters on the subject, the correspondence was dropped.

Lately there came into my hands two publications on these Kansas counties. One is a detailed description of them by Professor Charles S. Prosser, in vol. ii of The University Geological Survey of Kansas, Topeka, 1896; and the other is a paper entitled: On Outlying Areas of the Comanche Series in Kansas, Oklahoma and New Mexico, by Mr. R. T. Hill, this Journal, vol. 1, pp. 205-234, issued in September, 1895, but which entirely escaped my notice until one week ago, on account of my time having been completely occupied for several years by the writing and printing of the Life of Louis Agassiz.

I have studied with interest all the part of vol. ii, Kansas Survey, entitled "Cretaceous-Comanche series of Kansas," pp. 96-181. The author gives carefully observed sections, and an important geological map of "Southwest Comanche area." He is clear and exact, but the paleontological part is not only very meagre, but also incorrect so far as relates to the principal and very important fossil found, a rather large *Gryphæa*, collected on the top of one of the Belvidere sections. As he follows and uses the classification of Mr. Hill, my answer will apply to both memoirs.

According to two lists of fossils determined by Mr. T. W. Stanton, at pp. 216 and 219 of Mr. Hill's paper, the *Gryphæa Tucumcarii* Marcou has been found at Blue Cut Mound, four miles southwest of Belvidere, above the *Gryphæa forniculata*; and Mr. Stanton adds: "It is interesting to note that this form (*G. Tucumcarii*), supposed by Prof. Marcou to be Jurassic, here occurs above *G. forniculata*, which he considered Neocomian, though there is only a few feet difference in the beds and they seem to be connected by intermediate forms. The geographic distribution of the two species is about the same" (Hill's paper, p. 216).

At the beginning of the controversy by Mr. James Hall in 1855, continued afterward by Dr. B. F. Shumard, Dr. J. S. Newberry, Mr. R. T. Hill, and others too numerous to name, I realized that a misuse of paleontology had been made, and ever since paleontological misrule has held complete and unchecked sway in regard to the numerous *Gryphæa* found in the whole region south of the Arkansas river. After receiving specimens now and then from Texas and Kansas, I saw clearly that about eight or ten *Gryphæa* existed there at different levels, and that the confusion of species by Messrs. Hall, Römer, Shumard, Gabb, Charles A. White, Hill, Cragin and Stanton, was sure to result in a complete revision and exact description of all the *Gryphæa* found in the region. I know, and I have repeatedly said, that the identification of the numerous *Gryphæa Pitcheri* was wrong in almost every case, my own

included. Professor Ferdinand Rømer made the mistake in 1849 and 1852 in referring a New Braunsfelds and Red River species of *Gryphæa* to the *G. Pitcheri* of Dr. Morton. Following Rømer, and on account of a complete lack of specimens for comparison, I referred the *Gryphæa* of Comet Creek to the *G. Pitcheri*, although I was in doubt as to the correctness of the determination, for my specimens differed considerably from those figured by Rømer, and from the one figured by Morton. But at the same time I took the precaution to publish excellent and exact figures, in my two works, issued in 1855 and 1858. For several years, after my hasty visit to Comet Creek, I was convinced that the *G. Pitcheri* found there was a different species from the one published by Rømer and the one published by Morton; and in 1861, I called the Comet Creek species *G. Rømeri*, and have even since used that very appropriate name for the *G. Pitcheri* published with figures by Rømer and myself. ("Notes on the Cretaceous of Texas." Proc. Boston Soc. Nat. Hist., Jan., 1861, vol. viii, p. 95.) Dr. C. A. White did not make use of the name *G. Rømeri* and without explanation he many years after called the species *Exogyra forniculata*, changing the generic and the specific name.*

This is the way that erroneous paleontology has been constantly used by my adversaries.

We read in Mr. Hill's paper, pp. 225-226: "The species called throughout this paper *Gryphæa forniculata* White, is the same as the one from Comet Creek, Oklahoma, first figured by Prof. Marcou as *Gryphæa Pitcheri* Morton, and later called by him *Gryphæa Rømeri*. The nomenclature of the Gryphæata oysters of the Comanche series will be thoroughly revised in a separate paper which the writer has in print. Prof. Marcou's name *G. Rømeri* probably has precedence over *G. forniculata* White, but it may be shown neither of these will stand."

"This *Gryphæa* so abundant at Belvidere is likewise found in great numbers in the Kiamitia clays, not only about Denison and Fort Worth, but also along a persistent line of 300 miles from Goodland, Indian Territory, to south of the Brazos in Texas. Its hemera (*sic*) in Texas is exclusively confined to the Preston beds, and Prof. Marcou has always held that it is a Cretaceous form; it is the species upon which he established the existence of the alleged Neocomian in America."

* The *Exogyra Texana* Roem. or *Exogyra flabellata* Goldf. is also a sort of polymorph fossil like the so-called *Gryphæa Pitcheri*. The only way to put an end to the confusion created by calling almost every *Exogyra*, *Ex. Texana* and every *Gryphæa*, *Gr. Pitcheri*, is to make a complete revision of all the *Exogyra* and *Gryphæa* existing, with very careful study of each species and the exact location of each stratum.

“An interesting fact in the Black Hills and Blue Cut sections is that the large *Gryphæa* which comes in near the top of the shales is identical with the form collected by Prof. Marcou and is the species called *Gryphæa Tucumcarii* by him (later called *Gryphæa dilatata* var. *Tucumcarii*.)”

“Prof. Marcou insisted that the beds from which this species came were of Jurassic age, and upon its occurrence he maintained the existence of the Jurassic system in this region. It occurs at Belvidere, as on the original plains of the Kiamitia near Goodland, in Indian Territory, where it was last year collected by Mr. T. Wayland Vaughan* of my division, and at Kent† in Trans Pecos, Texas, stratigraphically above and intimately associated with the species which he calls *Gryphæa Pitcheri*. Thus we have in Kansas and Indian Territory Prof. Marcou’s alleged Jurassic species occurring stratigraphically above species he called Cretaceous, which facts forever remove any previous doubt, if any existed, in favor of his theory of the existence of the Jurassic formation in Texas, Indian Territory, New Mexican region.”

There is only a little difficulty in accepting the conclusion drawn by Mr. Hill with such confidence,—the *Gryphæa* collected in great numbers at the top of the section of Blue Cut Mound, near Belvidere, is not the *Gryphæa Tucumcarii*!

I have had in my possession, ever since 1888, beautiful and perfect specimens of that *Gryphæa*, and the idea that a paleontologist of the U. S. Geological Survey and a chief geologist of that Survey should call it *G. Tucumcarii*! was far from my thoughts. When such discoveries were made, as those claimed by Messrs. Hill, Stanton and Vaughan, their first duty was to give good figures and exact descriptions of the *Gryphæa* and put it side by side with the figures and descriptions given by me in 1858 (*Geology of North America, etc.*, plate IV and pages 43 and 38, Zurich, 1858). But as it is a simple assertion, presenting no basis for discussion, the reader of Mr. Hill’s paper cannot judge from the paper itself. The *Gryphæa* found on the top of the Belvidere section, above the beds con-

* In *Science*, April 2, 1897, vol. v, No. 118, p. 559, Mr. T. W. Vaughan says that he found in the vicinity of Arapaho (Oklahoma and Indian Territory) the *Gryphæa Tucumcarii* of Marcou, a fossil asserted by him to be Jurassic, which often occurs imbedded in the same matrix (as the *Gryphæa Pitcheri* of Marcou or *forniculata* of White). Thus he extends the error of Messrs. Hill and Stanton farther south than Belvidere (Kansas). Figures and description of the so-called *G. Tucumcarii* are entirely wanting, and Mr. Vaughan merely makes an assertion without paleontological proofs.—Note by J. M.

† At Kent the *Gryphæa Tucumcarii*, which there is the true species, is not above the *Gryphæa Pitcheri* (*G. Roemeri*) but below. And the pretended *G. Pitcheri* of Messrs. Dumble and Cummins belongs to two new species entirely distinct from the *G. Roemeri* or *Pitcheri* (see “The Jura of Texas,” loc. cit., p. 153).—Note by J. M.

taining the *Gryphæa Rœmeri* of the Neocomian of Comet Creek, is an entirely different species from the *G. Tucumcarii*, it is a new species which I propose to call *Gryphæa Kansana*. It possesses all the main characters common to all the *Gryphæa* of the Neocomian or Lower Cretaceous of America and Europe. As for Mr. Hill's announcement that "The nomenclature of the *Gryphæta* oysters of the Comanche series will be thoroughly revised in a separate paper which the writer has in print," almost two years have passed and the paper is not yet distributed. I hope that it will soon be out; and then, I shall publish figures and description of the large *Gryphæa Kansana*, n. sp. Messrs. Hill and Stanton do not seem to realize that if their identification of the *Gryphæas* at Belvidere and at the *Tucumcarii* region were correct, their discovery of one above another at one place and the reverse at the other place, in the same geological basin, among almost horizontal strata, would go far towards destroying the paleontological character for classification of strata, discovered almost one century ago, by William Smith, the author of "Strata identified by Organized Fossils" (4to, London, 1816). Happily their identification of the *Gryphæa Tucumcarii* with the *G. Kansana* is incorrect and their classification is based on paleontological misrule. There seems to be a sort of fatality, after the numerous false identification of half a dozen and probably more different species of *Gryphæa*, with the *G. Pitcheri*, to have now the same difficulty of incorrect identification of two distinct species of *Gryphæa*. It is discouraging in the extreme to see such a succession of blunders during more than forty years.

Now a few words on the age and classification of the Belvidere section and other outcrops in Kansas.

Professor Chas. S. Prosser gives a very good account of the strata under consideration, in vol. ii of the Kansas Geological Survey, although he also falls into the error of calling the new *Gryphæa Kansana*, of the top of the Belvidere section, *Gryphæa Tucumcarii*. Above the New Red sandstone formation of the plains south of the Arkansas River, lies in discordance of stratification a sandstone, called by Professor Cragin "the Cheyenne sandstone," of a thickness of about 50 to 60 feet. No characteristic fossils have yet been found in it. In fact fossils are very rare, only a few shells referred with doubt to *Avicula* and *Cucullea* having been found, and these so poorly preserved that Mr. Stanton has declined "to identify them even generically." In the upper part of the Cheyenne sandstone, a small flora, eight species, has been determined by Professor Knowlton, who says: "That up to the present time the dicotyledons from the Cheyenne sandstone are not known outside of the Dakota formation," that is to say the base of the

Upper Cretaceous or Cenomanian of Europe. No conclusion can be drawn from such a meagre florula. A Cycadæ, called *Cycladoidea munita* by Cragin, recalls the Cycadæ of the Purbeck beds of the island of Portland in England. As to the impossibility of having dicotyledonous plants in the Jura, as has been insisted upon by my adversaries, it is a very hazardous supposition without any solid basis to rest upon. The great number of species of dicotyledonous plants of the rich flora of the Dakota formation, indicates that we must expect to find dicotyledonous plants far below that formation; and to say that dicotyledonous plants did not exist during the Jurassic period, is merely a supposition, based on negative proof; a very uncertain, questionable basis to rest upon in our time of belief in evolution as well of plants as of animals. After the ill success of the great paleobotanist Oswald Heer, in the use of negative proof, to deny the existence of dicotyledonous plants in the Cretaceous of America, it is rather strange to see paleobotanists in America falling into the same error.

As the Cheyenne sandstone does not exist everywhere in Kansas, where the Neocomian, called Kiowa shales, is seen, as in Central Kansas, McPherton and Saline Counties; and as at Comet Creek, the Neocomian, with *G. Rameri*, rests in such places directly on the New Red sandstone rocks, it is most probable that it belongs to the Jurassic period, and is an eastern prolongation of the yellow and white sandstone of Pyramid Mount. It has the same lithology with brilliant colors, as noted by Professor O. C. Marsh, and future researches will decide its real and exact geological age. A great *desideratum* is the careful examination near Belvidere of the contact of the Cheyenne sandstone with the first three or four beds resting on it. Some sort of discordance, due to erosion and denudation, and perhaps also some little difference in the dip of the strata—a difference which can be only very small considering the almost horizontality of the strata of the plains—may be detected. Of course it will require prolonged research and a very acute practical geological mind, to discover such discordance. But I hope that some day the work will be undertaken. For me such a discovery is only a question of time. So far the discordance may be looked for between No. 6 and No. 7 of Mr. Hill's section. The Kiowa shales of Professor Cragin, so well described by Messrs. Cragin and Prosser, represent the Neocomian or Lower Cretaceous in Kansas, from No. 7 of the Belvidere section up; below they may be Jurassic.

Oklahoma.—The Comet Creek bed, as it is called by Mr. Hill, is not composed "of a single stratum of Gryphæa limestone, five feet thick," as he says (this Journal, vol. 1, p. 228); but of five strata or beds, which are described in my "Field

notes," published in vol. iii, Pacific Railroad Explorations, p. 131. Another example of want of exactness in quotation in Mr. Hill.*

The Tucumcari region.—It seems superfluous for me to speak again of my researches; but Mr. Hill's paper obliges me to state more forcibly, if possible, all the facts on which I have founded my conclusions that the Jura exists in this region.

The only section I was able to see and make during my very short stay of only 24 hours, the 21st and 22d of Sept., 1853, owing to the rapidity of our military march, was at an isolated peak west of the Big Tucumcari Mount, which I have called Pyramid Mount. Since the name has been used in the map of Lieutenant A. W. Whipple's expedition, and on my geological map of New Mexico, its geographical position is well established. I chose that hill on account of its complete isolation, and also because, after looking carefully through a spy-glass at the whole surroundings of Plaza Larga, I thought that the beds seemed better exposed to view and would afford me a good section. In this I was not disappointed, for as soon as I reached the foot of the hill, I had before me a most perfect geological section, almost like a wall; with every bed finely in view and accessible. I took the right side of the wall section, and carefully noted every thing I saw. As I have repeatedly published this section, I shall not give it again, only I would say that I did not see any mark of discordance of stratification by break or erosion between the beds of the New Red sandstone and the Jurassic formation. The bed of blue clay, above the yellow and white sandstone, containing near its base the *Gryphæa Tucumcari* and *Ostrea Marshii*, is fully in view. Before reaching the bed of *Gryphæa*, I failed to find in the sandstone a single fossil. Above the blue clay with *Gryphæa Tucumcari*, 30 feet thick, there is 52 feet of yellowish and white limestone. In this limestone a few *G. Tucumcari* were seen, also one or two not well preserved shells of lamelli-branchiæ.

I nowhere found the *Ammonites (Schlœnbachia) Shumardi*, even the smallest fragment. And from the nature of the rubbish (débris) at the foot of the wall of that section, which I examined with great care, I can say, that it is my conviction

* To finish with misquotations, I give the following foot note of Mr. Hill's paper, entitled: "A question of classification" (Science, vol iv, No. 103, p. 918, Dec. 18, 1896): "With the exception of Prof. Jules Marcou, who originally maintained that the Middle and Lower Cretaceous of Texas and the Plain Tertiary were Jurassic, and who still maintains the Jurassic age of the Middle Cretaceous beds of New Mexico and the Lower Cretaceous of Texas. This position has been disproved by research." It is sufficient for me to give it without comment, for seldom has an adversary been cited so inaccurately or his researches so incorrectly used.

that the *A. Shumardi* does not exist anywhere at Pyramid Mount; therefore its stratigraphic position in the Tucumcari region must be above the last bed of white limestone, seen at the top of Pyramid Mount. This remark is of great importance, for Professor A. Hyatt, in his exploration of another part of the Tucumcari region, insists that he has found the *A. Shumardi* in company with *Gryphæa Tucumcarii*. However great may be my respect and sympathy for Professor Hyatt, and though I fully acknowledge his great authority on cephalopods, regarding him as one of the few masters on everything touching *Ammonites*, *Nautilus*, *Lituites*, etc., I cannot refrain from expressing my doubt in regard to his finding *A. Shumardi* is the same layer, side by side with *G. Tucumcarii*. That Professor Hyatt saw the *Ammonites* very near the *Gryphæa*, I have no doubt; but I am sure the *Ammonite* must be above, even if only a few inches separate them. If the *G. Tucumcarii* exists above the *A. Shumardi*, and this is a well established fact, which can be easily proved by a careful and exact stratigraphist; then *A. Shumardi*, as I have said, is a Jurassic species, notwithstanding that it belongs to the genus *Schlenbachia*, which in that case made its appearance in America earlier than in Europe.*

That beds found at other parts of the Tucumcari region, lying above the two feet of white limestone of the top of Pyramid Mount, belong to the Lower Cretaceous or Neocomian is very probable, but I am not to be criticised for not finding them, for they do not occur at my section of Pyramid Mount. I found there only the Jura and I followed all the rules of stratigraphic classification, in referring the strata of Pyramid Mount to the American Jurassic formation. I saw clearly when I was on the top of Pyramid Mount, that on the mesa or plateau of the Llano Estacado, more especially toward the east, at Monte Revuelto, there was another series of strata capping the Jura of Pyramid Mount and consequently

* In my paper, "The Jura of Texas" (Proceed. Boston Soc. Nat. Hist., vol. 27, p. 155), I say that Professor A. Hyatt has found at the Tucumcari region the *Ammonites* (*Schlenbachia*) *Shumardi* with the *Gryphæa Tucumcarii*, "and there is therefore no doubt possible in regard to the contemporaneity of the *A. Shumardi* and the *G. Tucumcarii*." Messrs. Dumble and Cummins in their Kent section (American Geologist, vol. xii, 1893, pp. 309-314), also regard the *A. Shumardi* as contemporary with the *G. Tucumcarii*. Although I was not convinced by the assertion of Messrs. Hyatt, Dumble and Cummins, I admitted it, leaving the responsibility on those observers. But now, after the repeated failure of my adversaries to give the exact position in the strata of each species, I am unwilling to accept any longer such supposed contemporaneity, and I think that *Ammonites Shumardi* is younger than *Gryphæa Tucumcarii* and is placed above it in the strata; and that the line of separation between the Jura and the Neocomian at the Tucumcari region and at Kent, is between the beds containing the *G. Tucumcarii* and those above containing the *A. Shumardi*, with a break or discordance of some sort between them.

younger; but it was impossible for me to go to Monte Revuelto, or any other part of the Tucumcari region, to explore that upper series, and consequently I cannot be responsible for not having found at the Tucumcari region the Lower Cretaceous or Neocomian. It is very unjust to attack me in regard to the age of strata which I have not seen, and above all it is highly erroneous to deny the existence of the Jura at the Tucumcari region. My adversaries have made use of the anti-stratigraphic method of placing in a single list all the fossils they got there, without any regard to their relative positions in the strata. This placing in a single mass all the fossils of the Tucumcari region is not the way to make exact observations. I protest loudly against such a procedure. For it is easy to see the special purpose in view, viz: to show Cretaceous species mixed with Jurassic ones, and to conclude that the Jura did not exist there. It is contrary to careful stratigraphy to do so, and very unfair. Each group and even each bed should be given with the list of fossils found in each, otherwise lists of fossils all together are deceptive, and cannot be accepted as paleontological proof of the age of all the strata of a whole region. That the Lower Cretaceous exists at the Tucumcari region I am ready to believe, but the beds belonging to it are all above those which I have classified as Jurassic. In conclusion, I have to say that in the paper of Mr. Hill we have another example of erroneous determination of a *Gryphæa* which has led some geologists to continue their disbelief in the existence of the Jura at the Tucumcari. The Tucumcari region is open to every observer, and I am fully confident of the final verdict.

Tabular view of the strata of the Tucumcari region.

| | | |
|-------------|---|--|
| Cretaceous. | { | <p>Cretaceous strata of Monte Revuelto, six miles east of Pyramid Mount. Thickness about 200 feet. The contact bed with the Jurassic formation has not yet been described.</p> <p><i>Nota bene.</i>—Very likely a discordance of some sort exists at the contact of the Jura and Cretaceous.</p> <p>-----</p> |
| Jura. | { | <p>Jurassic strata existing above the top bed of the Pyramid Mount section. Thickness unknown.</p> <p>Jura of Pyramid Mount, with <i>Gryphæa dilatata</i> var. <i>Tucumcarii</i>, and <i>Ostrea Marshii</i>. Composed of yellow and white sandstone, of blue marl, and yellow and white limestone. Thickness about 200 feet.</p> |

Keuper or variegated marls of the Trias.

General Classification of the Jura and Neocomian south of the Arkansas river.—When, in 1887, Mr. Hill published his first essay of a “Geologic Section of the Cretaceous strata of the State of Texas, etc.” (this Journal, vol. xxxiii, p. 299, April 1887), I saw that there were important mistakes in his classification of the Lower Cretaceous; but I thought that he would correct them, in his further researches. Instead of improving his classification, however, and giving a clearer and more exact nomenclature, confusion has been aggravated, until I think it is time to interfere.

It is strange, that almost perfect stranger as I am, for I have explored a very small part of Texas, only a simple road in the Panhandle—I should be obliged again to attempt a more logical and exact classification, than the one in use by those who have in charge the description of the geology of that great and beautiful State.

In 1860, Dr. B. F. Shumard published his “Section of the Cretaceous strata in Texas” (Trans. Acad. Sc. of St. Louis, vol. i, p. 582); and in 1861, I gave before the Boston Society of Natural History a corrected section, reversing the whole classification from top to bottom (Proceed. Boston Soc. Nat. Hist., vol. viii, January 1861, p. 93). After many years of opposition and discussion my classification has been accepted as correct. It remained only to complete the details of subdivisions, and to keep the Jurassic formation distinct from the Lower Cretaceous. Mr. Hill in his first paper replaced the Jura in the Cretaceous, and ever since with some variations has continued to identify the Jura either with the Washita division, or with the lower part of what he calls the Lower Cretaceous (Trinity division). Only once, after his first visit to the Tucumcari region, has he recognized the strata containing the *Gryphaea dilatata* var. *Tucumcarii* and *Ostrea Marshii* as Jurassic; but as he said, he regretted it directly, and returned with new vigor to his classification of the Texas Jura, in the Lower Cretaceous.

The constant changes in Mr. Hill’s classifications render it extremely difficult to understand the meaning of the names he uses for the subdivisions, the great divisions and even his name of “Comanche series,” called first “Texas series.”* It is almost impossible to keep pace with him. Almost every year since 1887, when he published his first classification, he has brought forward a new one. To render the matter more confusing, the Geological Survey of Texas has also used different classifications in its annual reports, and we have now about ten different classifications to deal with.

* Mr. Hill, in his nomenclature, uses the name “Comanche Peak Group,” “Comanche Division” and “Comanche series;” rather too many Comanches.

For the present I shall not enter into any explanation of these classifications or show the numerous discrepancies between them. But I shall say only, that above what has been called "Dinosaur sand" or the true Trinity, we have a certain number of beds, called Glen Rose, Paluxy, Caprina and Caprotina limestone, Gryphæa rock and Walnut clays, Comanche Peak chalk and Goodland limestone—some of which are placed sometimes in the Trinity division, and at other times in the Fredericksburg—which require a careful study before they are placed either with the "Dinosaur sand" or with the Washita division. With this reservation I shall proceed to present a stratigraphic and paleontologic classification of the strata comprised between the undoubted Trias and the undoubted Upper Cretaceous.

A. Beginning with the base, we have first, the Trinity or Bosque division. The first description of it was given by Mr. Hill, in the second volume of the Arkansas Geological Survey, 1888. I repeat that I have shown with details, that the fauna found in it is a Jurassic fauna, without a single form which can be attributed to a Cretaceous species. In Pike County, Arkansas, round Murfreesboro, the upper portion of the Trinity division has been destroyed by denudation and erosion after the upheaval and break at the end of the Jura period. But it may turn out after more minute researches and observations, that the missing upper portion may be found in part, if not *in toto*, somewhere between Murfreesboro, Pike Co., Arkansas, and Tishomingo, Chickasaw Nation, in the Choctaw Nation territory, at or near the small stream called Kiamishi or Kiamashi, where Dr. Z. Pitcher found a small specimen of a *Gryphæa*, called by Dr. Morton *Gryphæa Pitcheri*.

The geographical distribution of the Trinity division follows a curved line from Murfreesboro, Arkansas, to Tishomingo, to Glen Rose, Somerville Co., to Bosque Co., and Travis Co. in Texas, crossing the Trinity River valley, from which it received its first name from Mr. Hill. Two different *facies* exist on that line. The first or Arkansas *facies* is composed of various rocks, such as grayish yellow limestone and argillaceous sand. The second or Bosque *facies* is less argillaceous, with more limestone, more especially in that portion of the division which has been called "Glen Rose (alternating bed)." West of Travis Co. or Austin, a third *facies* makes its appearance, formed only of sandstone yellow and white,

* The superposition of some of the subdivisions referred to the Glen Rose is doubtful, and some may belong to a younger formation. The Paluxy sand has also been classified by some as belonging to the Fredericksburg division, while others place it with the Trinity sand, without intercalation of the Glen Rose.

which has been called Paluxy sandstone near Comanche Peak and at the Kent County section; simply yellow and white sandstone at the Pyramid Mount section; and Cheyenne sandstone near Belvidere, Kansas. This third *facies* is the most persistent, occupying all the western country from Kansas to New Mexico, western Texas and very likely northern Mexico.

B. Following the Trinity division and in concordance of stratification we have the Tucumcari division, composed of blue marl at the base, containing a bed formed entirely of *Gryphæa dilatata* var. *Tucumcarii* and *Ostrea Marshii*; then comes a yellowish limestone with two or three feet of white limestone. The top of that formation has not yet been described. Very likely it exists at Monte Revuelto, in the Tucumcari region. The *Gryphæa Tucumcarii* is found scattered, more or less, through the whole division, but more abundantly at the base. At the end of the deposition of this formation, a great break occurred; denudation on a large scale swept away the greatest part of it, leaving now and then a small remnant; for instance at Belvidere, Kansas, where the strata numbered 4, 5 and 6, by Mr. Hill seem to belong to the lowest bed of the blue clay containing *Gryphæa Tucumcarii* of the Pyramid Mount section. At Kent, in Texas, the superior part of the Tucumcari division exists with the *Gryphæa Tucumcarii*; and more of that division will be found in the region of the Pecos River valley and also on the upper Canadian River region. As I have already said, the strata of the Kiamishi Creek valley in the Choctaw Nation, containing the original *Gryphæa Pitcheri* of Morton, may belong to the lower part of the Tucumcari division.

C. We next come to a new great period, the Cretaceous age, beginning with the strata containing an immense number of *Gryphæa Ræmeri*. When I say that the Cretaceous begins with the apposition of the *G. Ræmeri*, it is only a means of calling the attention of the observer in the field, for there are some strata below the true zone of the *Gryphæa Ræmeri*. For instance at Comet Creek, Oklahoma, we have one bed containing *Caprotina Texana*, with a form of *Exogyra Texana*; while at Black Hills, Kansas, we have thirteen feet of shales, numbered 7, 8, 9 and 10 in the section of Mr. Hill, containing no fossils, which very likely are already Cretaceous strata. I recall that No. 6 of Mr. Hill's section belongs still to the Jura, and that denudation or erosion very likely exists between number 6 and number 7, the last number beginning there the truly Cretaceous series. The presence of "occasional minute pebbles" in No. 7, indicate the disturbance after the break occurred at the end of the Jura, and is an important witness of the denudation and erosion.

With the *Gryphæa Rœmeri* zone, we have the beginning of an important series of strata, containing a Lower Cretaceous fauna well characterized and which can be subdivided into four or five sub-fauna and easily followed and studied between Belvidere, Fort Washita, Fort Worth and Comanche Peak.

We have three *facies* of the Lower Cretaceous or Neocomian. One is called the Washita *facies*, composed mainly of limestone and constitutes the true Washita division, as I established it as long ago as 1853, when at Comet Creek, near Fort Washita. The second *facies* is called by Professor Cragin "Kiowa shales," being composed mainly of shales, instead of the great development of limestone of the Washita *facies*. The second *facies* has seemed until now to be confined to the strata of Kansas. Then we have a third *facies* called Fredericksburg division, at Comanche Peak, Walnut, Goodland and further south.

A great deal of confusion has been caused by a sort of duplication of one single series, the true Washita division, which has been called in eastern and southern Texas Fredericksburg division. A careful survey of all the strata composing the Lower Cretaceous between Fredericksburg, Austin, Comanche Peak, Fort Worth, Fort Washita and Comet Creek is much needed. For it is plain that the Comanche Peak and Kiamitia clay or Preston subdivisions are simply the base of the Washita division, which cannot be separated from the Fort Worth limestone.

Therefore, instead of the classification used by Mr. Hill under the single name of "Comanche series" or Lower Cretaceous, composed of these divisions, 1st the Trinity, 2d the Fredericksburg, and 3d the Washita, we have the Jurassic series composed of the Trinity and the Tucumcari division, and the Lower Cretaceous or Neocomian composed of the Washita division; dropping the Fredericksburg, which is only a *facies* of the Washita, and placing the Tucumcari division in its true stratigraphic and paleontologic position.

General tabular view for the whole country south of the Arkansas River:

Upper Cretaceous.

| | | |
|---|---|--|
| Break. _____ | | |
| Neocomian or Lower Cretaceous. | { | C. Washita Division. |
| | { | Comprising all the subdivisions, as well as the Kiowa and Fredericksburg <i>facies</i> . Zone of the <i>Gryphæa Kansana</i> . Zone of the <i>Gryphæa Rœmeri</i> . |

Break.

| | | |
|-------|---------------------------|--|
| Jura. | B. Tucumcari Division. | <p>Until now this upper part of the Jurassic formation has been best preserved in the Tucumcari region. A few remnants exist near Belvidere (Kansas), at Kent (Texas), and possibly in the Choctaw Nation.</p> <p>Zone of the <i>Gryphæa Tucumcarii</i> and <i>Ostrea Marshii</i>.</p> |
| | A. Trinity Division. | <p>Best developed in Pike County, Arkansas, and Bosque County, Texas.</p> <p>Represented in Kansas by the Cheyenne sandstone; at Pyramid Mount, New Mexico, by the yellow and white sandstone; and at Kent, Texas, by sandstone called Paluxy.</p> |

Resting on the New Red sandstone or the Palezoic series according to different parts of the country.

Cambridge, Massachusetts, May, 1897.

ART. XXIV.—*On Pithecanthropus erectus*; by Professor L. MANOUVRIER of the Paris School of Anthropology.*

Extracts selected from two articles: "The *Pithecanthropus erectus* and the Theory of Evolution" (*Revue Scientifique*, 4^{me} sér., t. v), and "Response to the Objections against the *Pithecanthropus*" (*Bull. de la Soc. d'Anthrop. de Paris*, 4^{me} sér., t. vii). Translated by George Grant MacCurdy, M.A.

THE *Revue* has already said a few words about an important scientific event which I now propose to discuss more fully.

It is a question of the discovery in Tertiary strata near Trinil, Java, of bones which seem to have belonged to a being intermediate between man and the anthropoids. This could be a precursor and perhaps an immediate ancestor of the human species, the link, heretofore lacking, of the chain which, according to the theory of evolution, ought to unite without interruption *Homo sapiens* with the rest of the animal kingdom. The author of this discovery is Mr. Eugene Dubois, physician in the Dutch army. The occasion was a vast geologic exploration made in Java, from 1890 to 1895, under the auspices of the government of Holland.

Such good fortune did not come to Mr. Dubois by hazard. He was attracted to the Indian archipelago in the hope of finding there, by means of important excavations about to be undertaken, the famous Missing Link theoretically foreseen, the existence of which should antedate Quaternary times. Certain hypotheses even considered the "Iles de la Sonde" as a possible cradle of the human race. Mr. Dubois, then, was guided by theoretic views; and if he has been fortunate in his research he has merited it by his competence as geologist and anatomist, also by the talent with which he has known how to turn his discovery to account.

It is all very well to find an inscription, it is another thing to decipher it. This latter task, as will be seen farther on, presented great difficulties which Mr. Dubois has overcome in a most creditable manner.

A very incomplete skull, two molar teeth picked up at a meter's distance from the skull, and a femur lying at some fifteen meters' distance, the whole enveloped in an earthy gang, very hard, and occurring in a bed which included other remains of a Pleistocene fauna to day for the most part extinct—such are the pieces of a more or less human appearance of which the specific determination was in question. It is obvious that

* Two illustrated papers on the *Pithecanthropus erectus* have already appeared in this Journal, both by Professor O. C. Marsh, who from the first regarded this new form as intermediate between man and the higher apes. See vol. xlix, p. 144, February, 1895; and vol. i, p. 475, June, 1896.—Ed.

the inscription to be deciphered is far from being perfect; the letters remaining are few. But these are the initials, and in the connection in which they are found, chance has served science almost as well as a judicious choice among all the parts of the skeleton could have done.

The two molars represent, in reality, in addition to the maxillary bones and the face, the vegetative function; the femur represents the function of locomotion; what is left of the skull suffices to give important indications as to the cerebral and intellectual development.

Although these different pieces were found separated a certain distance one from the other, the conditions of the deposit and the circumstances of the excavations have convinced Mr. Dubois that they belonged to one and the same individual. He has made a thorough and very careful study of them,* of which the conclusion is that they attest the existence, in the Pleistocene epoch, of an anthropoid species of biped intermediate between the known anthropoids and the human species, precursor of the latter and probably descended from the genus *Hylobates* (Gibbon). In consequence, the new species received the name of *Pithecanthropus erectus*.

Strongly supported as they were, these conclusions were destined to move more or less, not only the specialists in zoology, anthropology, and paleontology, but also the entire thinking world. Appearing toward the end of the year 1894, Mr. Dubois' memoir was not slow in provoking criticisms and discussions, the history of which is not without some interest.

January 3, 1895, I communicated to the Paris Society of Anthropology† a detailed estimate, based upon the study of the drawings, photogravures and tables, contained in Mr. Dubois' paper, and which, in part favorable to the conclusions of the author, may be summed up as follows:

It is not certain that the specimens in question belonged to the same individual nor even to a single species, but it is possible, for there is no lack of anatomical correlation among the different pieces.

The femur, for the human species and according to my tables for the reconstitution of the stature‡ would correspond to a height of about 1·657^m. This femur, by its pilastric index§ or index of a transverse section at the middle point of the

* *Pithecanthropus erectus*, eine menschenähnliche Uebergangsform aus Java (Batavia Landesdruckerei, 1894).

† Discussion du *Pithecanthropus erectus* comme précurseur présumé de l'homme (Bull. Soc. d'Anthr., fasc. 1, 1895).

‡ Mém. sur la détermination de la taille d'après les grands os des membres (Mém. Soc. d'Anthr. de Paris, § 2, t. iv, 1892).

§ Étude sur les variations morph. du corps du fémur dans l'espèce hum. (Bull. Soc. d'Anthr., 1893.)

diaphysis, indicates certainly a biped attitude. But it does not present a single character permitting one to attribute it to any other species than the human. Yet that invalidates in no way the general conclusion of Mr. Dubois, because on the hypothesis, where an anthropoid race would have passed from the attitude of a climber to the attitude biped, the transformation of the femur ought to have preceded that of the skull.

The tooth (3d upper molar) is too large sized, its roots too divergent to admit of its being attributed to man. I have been able to find only one human tooth (in a New Caledonian skull) which presents at once so large a crown and of which the principal axis is at the same time directed from before backward, but this is a third lower molar and its roots are not spreading. On the other hand, the grinding surface of the fossil tooth from Java differs much from the known teeth of anthropoids. It should then be considered as having belonged either to an anthropoid race, or to a human, no longer living.

The skull, according to Mr. Dubois' calculations confirmed by my own, has a capacity of from 900 to 1000^{cc}. This capacity exceeds by about 400^{cc} the maximum found among the largest anthropoids. On the other hand, it is too small to be compatible with a normal human intelligence, save among individuals of very small stature having a cranial capacity relatively large with reference to their stature and with reference to the average of their race. But, even discarding the teeth and femur about which there is some doubt, the morphologic characters of the cranium from Java suffice to denote a cerebral volume relatively very weak. The skull then must have belonged either to a normal individual of a race intermediate between the grand anthropoids and man, or to an abnormal man, to an imbecile, microcephalous for his race. This last supposition has the disadvantage of admitting the extraordinary encounter of an anomaly; if such an encounter is, strictly speaking, possible, it is hardly probable. In short, at least, a skull morphologically intermediate is in question. It is not certain that this skull represents the normal state of a fossil human race equally intermediate, but it is still less certain that it is a question of a simple anomaly. Consequently, the hypothesis of Mr. Dubois is scientifically legitimate.

Such were my first conclusions in January, 1895. But very different conclusions were reached at about the same time in Germany and in England.

At the Berlin Society of Anthropology,* the question was examined by Krause, Waldeyer, Virchow, Luschan, and Nehr-

* Zeitschrift für Ethnologie, Heft i, 1895.

ing. There, the femur was declared human and the skull attributed more or less affirmatively to an anthropoid.

On the other hand, Cunningham at Dublin and Sir W. Turner at Edinburgh pronounced both skull and femur human; Rudolph Martin* of the Zürich University was of the same mind.

Such a divergence of opinions expressed by these anatomists, all of them so competent, would almost suffice to demonstrate the really intermediate state of the skull from Java, for it is well known how great the difference is between a human skull and that of a monkey. To give occasion for opinions so opposed, it was necessary that the skull from Java should present important characters human and important characters simian.

That which explains also the divergence in question, is that the human skull drops now and then to a simian level among the microcephalous of all races, and to a level approaching the *Pithecanthropus* among certain inferior individuals, especially in the lowest savage races.

The skull from Java is no less remarkable in its general form than in its weak capacity. Its entire median curve is extremely elliptic; the forehead is extremely narrow and taper-

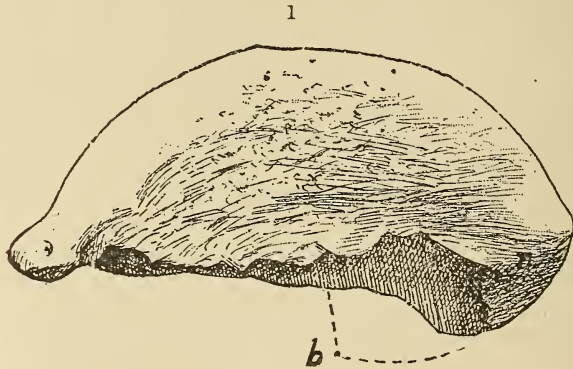

FIG. 1 (fig. 53).—Profile of the cranial cap of Trinil; *b*, Approximate position of the basion; *n*, Rudiment of the temporo-occipital crest.

ing. The lower portion of the frontal bone above the orbits forms a sort of visor of which the relative prominence surpasses all known proportions in the human species, not excepting, even, the famous Neanderthal skull. The lateral projection of this visor is not less extraordinary and denotes a great depth of the temporal fosses. The frontal region presents a

* Kritische Bedenken gegen den *Pith. erect*, Dubois (*Globus*, Band lxxvii, No. 14.)

lateral flattening which gives to the ensemble of the cranium a pyriform aspect when seen from above. The posterior parietal region is flat from above downward to a degree no less remarkable. The occipital crest is very thick. The temporal crests do not come very near to the sagittal suture, but they are prolonged downward and backward in such a way as to form a parietal super-mastoid crest which goes almost to form a junction with the occipital crest. I at first pointed out with some reserve this simian character after a photogravure in Mr. Dubois' memoir; but I am now no longer in doubt as to its reality. Finally the foramen magnum and the auditory meatus, which are missing, appear to have been situated a little farther back than in the human species.

As has been said above, human crania very inferior for their race sometimes approach more or less in volume and form to anthropoid crania. Professor Turner* has also been able to show many exceptional human skulls that approach to a remarkable extent the skull from Java with reference to capacity, etc. But, if we suppose that collections of crania richer than those that we possess would permit us to find upon human crania all the characters of inferiority noticed on the *Pithecanthropus* and to a degree as pronounced, the skull from Java would present none the less this peculiarity: that it brings together a group of characters all of them the limit for the human race. It is the union of these characters that it behooves us to consider, all the more so that the coexistence of certain of these characters on the same skull is particularly interesting. Thus normal human crania can have an inferior capacity of 1000 cubic centimeters, but then these are pigmy crania, and they come up again with respect to the general form because they contain a brain relatively voluminous with reference to the stature; they have no right, so to speak, to that enormous frontal visor which is, among all races, the lot of individuals with powerful skeleton and brain *relatively* small, or of averred microcephalous individuals whose development of skeleton approaches the medium.

Besides, let us admit that a non-pathological human skull may be found in which are united all the "*caractères limites*" of the skull from Java; that would prove nothing against the hypothesis of Mr. Dubois, for such a skull would be always a very rare exception in any human race whatsoever, whereas, according to all probability, the one skull found in Java is not a rare exception in its race. And then this race is of the Pleistocene epoch, which of itself would give no ground for astonishment were its one known specimen morphologically

* Jour. of Anat. and Physiol., vol. xxiv, 424.

inferior to our present races. We will refer further on to this question.

The opinion expressed in Germany is explicable, in the first place, by the fact that they commenced by attributing the femur of Java to a man without further question. In the second place, they emphasized too much the simian characters of the cranium and teeth. They saw that, according to these characters, the race of Java could not be attributed to the human species, but forgot that, according to other characters, they had no right to attribute it to the race of monkeys. For no known anthropoid approaches the fossil race of Trinil either by its cranial capacity or by its occipital characters at an adult age.

Besides, a view of the remains themselves and a more thorough study of them have already resulted, so it seems, in a change of the opinions first expressed.

Be that as it may, Mr. Dubois can congratulate himself on seeing placed in relief, at Berlin, the reasons according to which his *Pithecanthropus* could not be a man and, in England, much better reasons according to which the same *Pithecanthropus* could not be a monkey.

The question rested there until the International Zoölogical Congress was held in Leyden, September, 1895. At this congress, where were found such eminent zoölogists and anatomists as Sir W. H. Flower of London, A. Milne Edwards, Perrier and Filhol of Paris, and others, Mr. Dubois showed the fossil pieces from Trinil, to which was added another tooth (2d molar) which he mistook at first, before having completely cleared it from its matrix, for a tooth of *Swida*. The view of the originals did not result in calling forth decided affirmations from the Congress. According to the information that I received from Mr. Dubois and from Professor Kollmann of Båle, and according to a communication made to the Paris Academy of Sciences by Milne Edwards, the question was considered as demanding further research. Professor Virchow, without committing himself, emphasized certain pithecoïd characters of the skull and femur, notably the resemblance of the femur to that of the gibbon; he showed especially that, according to researches made in the collections of Pathological Anatomy of Berlin, the voluminous osseous vegetation presented by the femur of Trinil in the posterior sub-trochanterian region might be due to an abscess from congestion of the thigh, probably following a caries vertebral.

Mr. Dubois having satisfied himself, at Leyden, that the direct view of the fossil remains from Java contributed much to corroborate his demonstrations, kindly took those remains first to Brussels, then to Paris, then to Dublin, to Edinburgh,

London, Berlin and Jena. He will set forth, without doubt, in the near future the happy effects of that scientific tour upon anatomists when he describes the fossil fauna (Upper Pliocene) contemporaneous with the *Pithecanthropus*. The opinion adopted seems to be to-day very generally analogous to the one set forth at the beginning of this article.

It is the aspect of the specimens from Trinil and their complete

2.

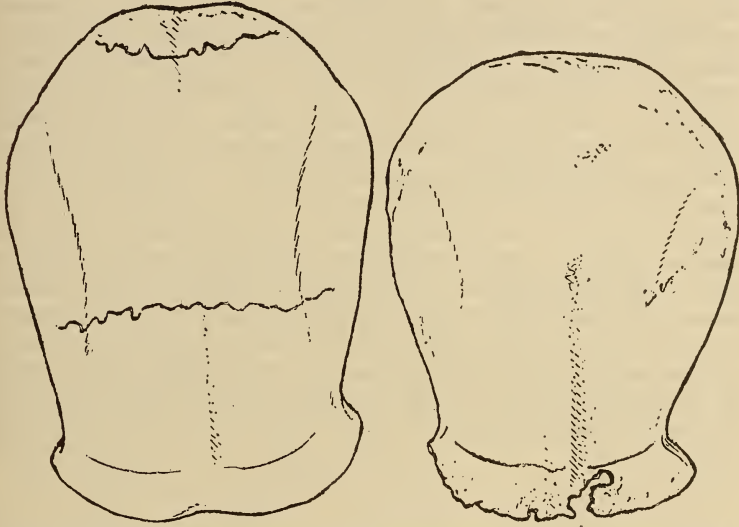

FIG. 2 (fig. 54).—*Norma verticalis* of the skull of Trinil compared with that of the Neanderthal skull.

fossilization, which surpasses by far that of all human remains, even the most ancient known until then, that tend more powerfully than all demonstration to place them as contemporaneous and as coming from one and the same individual, especially since there exists among them no want of anatomic correlation. The degree of fossilization is such that the femur attains the weight of 1 kilogram, whereas prehistoric femurs of the same size do not exceed 350 grams. All that, joined to the conditions of the deposit, adds value to the divers anatomic facts and deductions given above, and constitutes a mass of arguments before which it becomes difficult not to surrender. Without doubt, these diverse fossil pieces, which all present characters intermediate between the human and the simian morphology, these diverse portions of the skeleton which are all explained the one by the other, do not come from two or three different species which would have met in some way by

special appointment within a space of a few meters to leave there, one its skull, another two teeth, and a third its femur, the whole without want of correlation.

As regards the femur, I have studied particularly the character upon which Mr. Dubois insists, viz: the almost cylindrical form of this bone in the popliteal region, 4 centimeters above the upper margin of the condyles. At this level, the transverse diameter is ordinarily much greater than the antero-posterior diameter. On the femur of Trinil these two diameters are almost equal. At the same time, if we measure, beginning at a point anterior m , two antero-posterior diameters, the one ending at the median point p , the other at the point n situated on the external branch of the bifurcation of the linea aspera, we find $mn < mp$. I have been able to find this double character on only six human femurs out of more than a thousand belonging to races very diverse. Again it is less accentuated than on the femur from Java, so that this femur presents also in this respect a new "*caractère limite*" for the human species. One human femur alone presented this character to the same degree as the femur of Trinil; it is a Parisian femur of the Middle Ages, and this bone is pathologic; it presents grave coxalgic lesions and divers characters attesting a consecutive functional impotence. A detailed interpretation of the character in question is found in the *Bulletin de la Société d'Anthropologie* (t. vi, 4^{me} sér.). It can be summed up as follows:

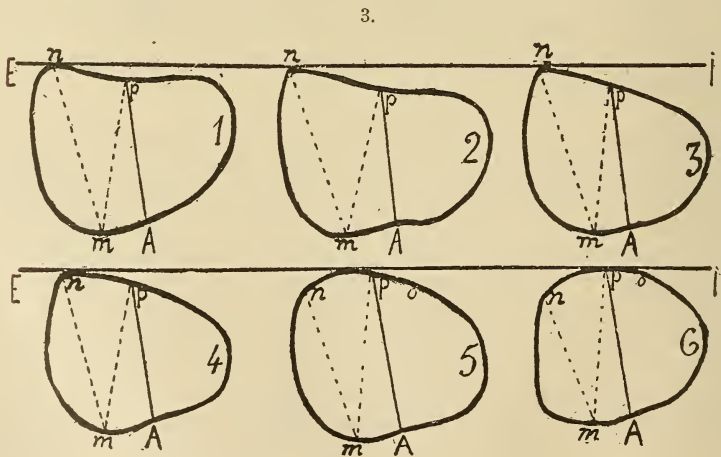

FIG. 3 (fig. 55)—Transverse section of the femur 4 centimeters from the upper margin of the condyles.—Scheme representing the passage from the common type 1 to the form of the femur of Trinil 6.—EI, Transverse axis.—Ap, Antero-posterior axis.

This character can be produced sporadically in any race whatsoever; it does not seem to possess any ethnic value in the human species, it seems to be connected most often with a certain muscular weakness and can be the result of a lesion affecting the upper part of the bone. As the femur of Trinil presents exactly such a lesion, resulting itself from a malady capable of entailing during a period of years a relative impotence of the lower members, it is quite possible and, I believe, even probable that if we should find a second femur from the same race, it would be very different from the one we possess.

This has none the less a very great importance, because it attests peremptorily the "marche bipède" which the cranial characters had been powerless to demonstrate in a sufficient manner, and the rather large size of the subject. It is sufficient for us to know that the femur of Trinil is not that of a monkey but that of an animal maintaining the upright position, an idea which is not in the least disturbed by pathologic considerations. If the femur in question had been completely sound, its form would have approached even more the ordinary human form. Such as it is, it does not recall, in my opinion, the femoral form of the gibbon any more than the Quaternary femur of Spy, described by Mr. Fraipont, recalls the femoral form of the gorilla, provided one does not take into consideration the characters connected with an upright position. In other words, the femur of Spy, although human, would not be less pithecoïd than that of Java.

Mr. Hepburn* of Edinburgh does not regard the characters of the femur of Trinil as sufficiently pronounced to form a genus distinct from the genus *Homo*. These characters are human and not simian. Upon this point, we are in accord. He adds that if the femur comes from a human being, and if the teeth and skull belong to the same, then the conclusion relative to the femur should apply also to the skull and the teeth.

On this last point, the justice of the conclusion depends on the signification attached to the term *human being*. If the femur of Trinil, considered separately, proves that its possessor was not a monkey, it certainly does not prove that its possessor ought to be classed according to the totality of its conformation in the human species, or genus, so far as known. I have already insisted at length upon this fact, that the femur can be morphologically very human in a being low enough with respect to cranial development to merit only conventionally the name of man. It is necessary, then, to take into account its skull and its teeth, as well as its femur, in an estimation of

* Journal of Anatomy and Physiology, vol. xxxi.

the fossil individual from Trinil. According to the femur, it would be a man with a perfect title to the name; according to the skull and the teeth, it is a creature low enough, in relation to the lowest human races, to be considered as passing beyond the lower limit for the human species or genus, so far as known, in the measure that its inferiority represents the inferiority of its race. It is this last point that rests in the condition of a hypothesis, but of a hypothesis which has for itself the greatest possibility. This hypothesis admitted, we are obliged to agree, viewed from the point of view of the theory of evolution, that the individual of Trinil, incontestably hominian, presents an ensemble of anatomic conditions responding marvelously to that which the theory of evolution could look for in an ancestral race.

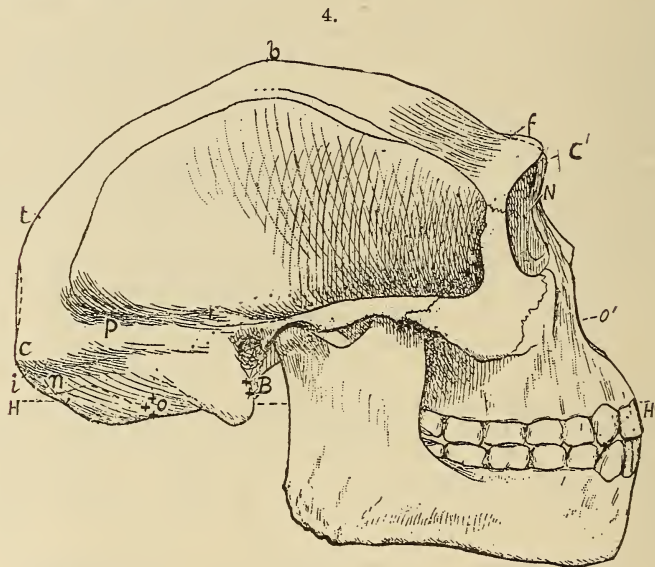

FIG. 4 (fig. 56) — Attempt at the reconstruction of the skull of *Pithecanthropus*.— B, Basion. The points marked about the letter B indicate the limit of possible errors.—C, Occipital crest.—*pt*, Inferior parietal crest almost joining the occipital crest.—*i*, Inion.—*HH'*, Horizontal plane of Broca (alveolo-condylar).—*BA*, Basioauricular line.—*BO*, Plane of the foramen magnum.

As regards the skull, I have been able, by virtue of the cast kindly given to the Anthropological Laboratory by Mr. Dubois, to attempt the graphic reconstruction. I made the attempt simply to satisfy myself of the aspect resulting from diverse craniologic proportions, but I believe I have obtained a drawing conforming approximately enough to the reality to be of interest to anatomists.

The maximum error possible for the separate points of the skull has been limited by correlations so diverse and

5.

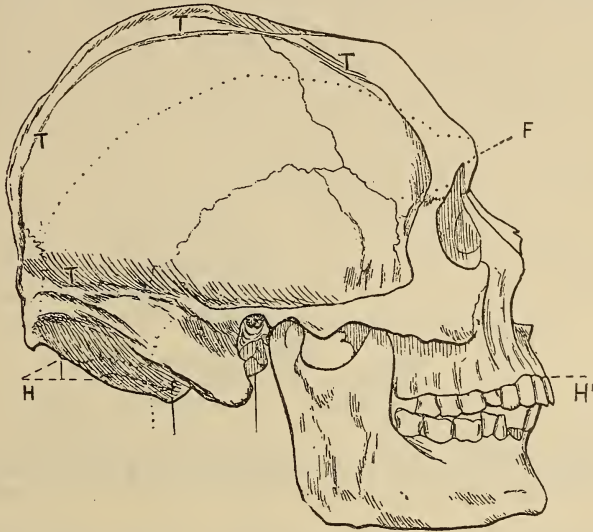

FIG. 5 (fig. 57)—Skull from Turkestan of bestial aspect in which is inscribed, by means of a dotted line, the cranial cap of Trinil.—IF, Inio-orbital line common to the two skulls.—T, Curved temporal line of the skull of Turkestan. This skull is extremely remarkable for the extent of the surface of insertion of the temporal muscle. It presents the crest *pt* of figure 4 (56). The sincipital region is mutilated by a sabre stroke.

rigorous that the errors which could have been committed cannot modify them, notably the general form of the skull,

6.

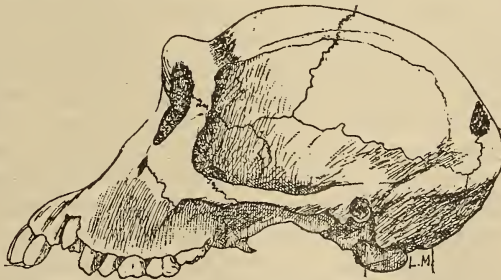

FIG. 6 (fig. 58)—Skull of a young chimpanzee.

properly speaking, and its orientation. The figure thus obtained seems to me to make it evident that, it is impossible,

with the cranial cap of Trinil, to construct a skull having an appearance either completely human or completely simian. The occipital characters which I attributed to it differ radically from those of adult anthropoids; in vain did I orient it in

7.

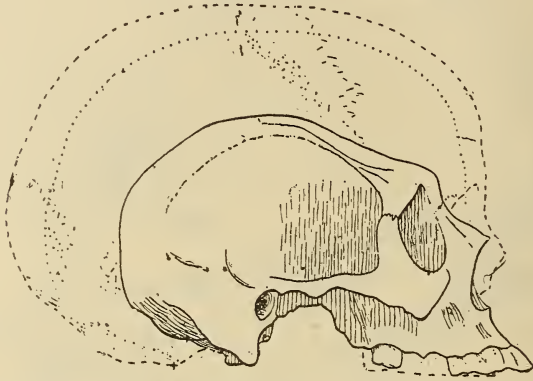

Fig. 7 (fig. 59)—Skull of *Margaretha* Moehler, microcephalous adult of Carl Vogt. The dotted lines represent two well developed feminine crania from Paris; one large, the other small. The auditory meatus is the point of superposition.

superposing it upon a human cranium; it had not, for that, an appearance suitably human, and we attempt in vain to pivot it about its bi-auricular axis in order to give it an air more human or more simian: we are struck by divers incompatibilities. The truth, which, I think, will appear clearly to all craniologists, is that the skull from Trinil represents the morphologic stage of the young anthropoid, a stage during which these animals approach man in important cranial characters much more nearly than at the adult age.

The adult *Pithecanthropus* possessed these characters of the young anthropoid; such is the result of our attempt at reconstitution, result independent, I repeat, of incurring chances of error, independent also of any preconceived idea, for I have striven only to place each separate point of the cranium and each line conformably to anatomic correlations without pre-occupying myself as to the final result. It has been admitted that the two molars, the femur, and the skull belong to the same individual, but this hypothesis has not exercised the least influence upon the drawing of the cranial region, properly so called. The technical details and justifications are to be found in the *Bulletin de la Société d'Anthropologie* above mentioned. I present here only a few drawings, which may be compared advantageously with the preceding.

The fact that the skull from Java bears such a strong mor-

phological resemblance to that of a young anthropoid is of a nature to explain the divergence of opinions, some of which ascribe it to a monkey, others, to the human species. But as it is a question of an adult, this fact is pronouncedly in favor of ascribing the skull to the human species with the reserve that it occupies a rank morphologically intermediate between anthropoids and the lowest human races. However, an anthropoid maintaining the upright position and possessing such a cranium is nothing less than a low order of human, for it has lost the essential traits which differentiate man from anthropoids. It is understood in this sense that the opinions of Turner and Cunningham do not differ from mine.

The important thing is the establishing of the fact that the craniologic inferiority of fossil human races, according to the specimens we know, increases with their antiquity. The discovery of Mr. Dubois contributes to establish this fact.

Let us represent by a line AD the entire family of Homi-
nidaë, which, for the theory of evolution, includes, in addition to the genus *Homo* in its known state CD, an unknown fossil portion CA, connecting the known portion with an anthropoid ancestor whatsoever A. When we say that the individual from Trinil belongs to the human species, that signi-

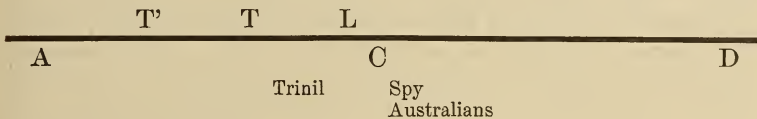

fies that it can enter into the portion CD within the limit L, which, for the anti-evolutionists, the human species must not overlap.

When it is said, on the contrary, that the race of Trinil is inferior to all known human races including the portion C, it is considered thereby even as one of those intermediate races TT' which, according to the theory of evolution, ought to have formed the unknown portion of the line AD.—Whether or not we place this race under the genus *Homo* (which is of little moment for the evolutionist), we consider it as one of the intermediate fossils theoretically foreseen. To contradict this opinion and to attach the man of Trinil to the race of Spy is to admit that it is a question always of the portion CD representing without theory the species or genus *Homo*. Such was the former opinion of Turner and of Cunningham; opinion which has been perhaps modified since the direct examination of the specimens under discussion.

According to the contrary opinion, the *Pithecanthropus* represents one of those fossil human races that the theory fore-

saw, for it is morphologically intermediate, by its skull, between the lowest human races and the anthropoid type. A partisan of the theory of evolution has no repugnance to considering that race as human and to saying "the man of Trinil," since, according to the theory, the chain AD is necessarily uninterrupted. Whatever be the names that we shall judge proper to give to the divers links of this chain, it will be a question always of man more or less inferior as far as the point where, the type of "bipède marcheur" disappearing, we shall emerge from the definite family of *Hominidæ* to enter into another branch of the genealogic tree of Man.

If it is preferred to settle the question by saying that the skull of Trinil simply puts back the limit L beyond its present position, just as the skulls of Spy have extended this limit as regards the races of Europe: from what I have just said I should not see the slightest objection to that, since it seems to me this limit L is destined to be put back by successive degrees as far as to the level A.

Theoretically it is highly probable that an anthropomorphous species, evolving toward the human type, ought to have realized at first in the adult state the characters of superiority that it possessed transitorily in the young state before that evolution. The disappearance of these infantile characters of superiority results, as I have shown in a former memoir,* from the precocious arrest of development in the cerebral mantel, when the central and inferior encephalic region as well as the basilar region of the skull continue to grow, keeping pace with the general development of the body. The *Pithecanthropus* would represent then that inferior phase of human evolution in which the intellectual and cerebral improvement would have been just enough so that the development of the upper portion of the skull would not be left in arrears any more than it is in the young anthropoid compared to the basilar development correlative to the corporeal growth in general. Among the lowest existing human races, this stage of evolution is largely exceeded for the normal individual. The difference is yet greater for the average among European races.

At any rate, the quality of precursor attributed by Mr. Du Bois to his *Pithecanthropus* reposes upon an ensemble of facts of consequence enough to merit the most serious attention. In addition, behind this hypothesis there arises another to the view of the evolutionist. It is quite natural to propose the question whether the precursor were not something more, that is to say an immediate ancestor of man or of a part of the human species.

* Sur les modif. du profil encéphalique et endocr. dans le passage à l'âge adulte, etc. (Bull. Soc. d'Anthr. de Bordeaux, T. 1, 1884).

The hypothesis of a simple precursor can be accepted without repugnance independent of the doctrine of evolution. It simply places an intermediate species between anthropoid and man and confirms once more the adage: *Natura non facit saltus*. It reduces itself to a simple verification. In favor of this hypothesis there will be, on the one hand, all the arguments produced to demonstrate that it is a question of the anthropoid species, but veritably simian, until then unknown; and on the other hand, all the arguments produced to demonstrate that it is a question of the human species.

The hypothesis of a veritable ancestor will profit by all these arguments, for all will tend to establish the existence of an uninterrupted chain. In insisting upon the simian characters we strengthen, voluntarily or not, the affiliation of the *Pithecanthropus* with monkeys; in insisting upon the human characters, we render more probable the affiliation of the intermediate species with the human.

The scientific event due to the laborious researches of Mr. Eugene Dubois is of a nature to give joy to all friends of science, but it seems to be more particularly agreeable to evolutionists, that is to say, to those who desire and pretend to explain why *natura non facit saltus*. For these last, the question whether the *Pithecanthropus* ought to be classed with the genus *Homo sapiens* depends upon the value attached to the qualifying word *sapiens*, the value of which is already very relative. As to the question of species it is, for the evolutionist, like the preceding, a simple question of degree of morphologic differentiation.

It is none the less interesting to search for the particular simian genus to which would fall the honor of becoming founder of the human branch, in other words the known anthropoid genus to which is allied the intermediate *Pithecanthropus*.

Mr. Dubois has thought of the genus *Hylobates* (Gibbon) and the general opinion at present seems to accord with this view. All the appearances are in its favor, because of the relatively grand analogies which exist between the conformation of the gibbon and that of man.*

The almost vertical attitude of the Gibbon corresponds to the very marked anatomic particularities which would render easy the human transformation. The conditions of this transformation, that is to say of the passage from the state of climber to that of "marcheur bipède," ought to have been very imperious, for it is difficult to believe that, without that, a race of climbers took spontaneously the initiative in renouncing a

* Paul Broca: L'ordre des Primates (Bull. de la Soc. d'Anthr., T. iv, p. 228, 1869).

mode of locomotion in harmony with an adaptation instinctively and organically fixed.

One hypothesis among others would be the destruction, more or less complete, of the forests on an island inhabited by anthropoids capable of taking, when necessary, the biped attitude. The ancient volcanoes of Java might have accomplished this destruction and have rendered necessary the adaptation to the upright position under pain of extinction of the race.

It would be impossible to explain easily the disappearance of an anthropomorphous species as much superior to all others as was that of the individual from Trinil; for it was strongly built with a cerebrum superior to all known species of the order of Primates. It possessed, then, excellent chances of survival in the struggle for life. But, on the hypothesis here considered, the species *Pithecanthropus erectus* would not have disappeared. Having become a human race, it could not remain at the same time a race anthropoid. If the *Pithecanthropus* was only a simple precursor, it was superior enough to the other animals to survive unless the human species, springing up all of a sudden, "from the clay of the earth," did not hasten to annihilate this dangerous competitor. But if the *Pithecanthropus* was an ancestor, its species lives yet in its human descendants.

The difference between the *Pithecanthropus* and existing man is so small that there is no call to search for an intermediate link. The link is sufficiently represented by the lowest of our savage races; for example, the isolated human skulls, Australian and others, that have already been shown to be very little different in many respects from that of Trinil.

Supposing that among several species of gibbon, Gx , Gy , Gz , this latter species evolved toward the human type and became finally, in assuming the upright position, the *Pithecanthropus erectus* = H^1 , then that it, by virtue of the multiple consequences of the upright position, became progressively H^2 , a stage corresponding to the lowest existing races, we obtain in simplifying:

Gibbon x

Gibbon y

Gibbon z — H^0 —(P.E. = H^1)— H^2 .

There ought to be then in the existing fauna a hiatus formed by the transformation of the gibbon z into H^0 , then of H^0 into H^1 , so that, in this existing fauna, the species nearest to H^2 ought to be a species very inferior, issue of gibbon x or y . The gap here ought to be all the greater in that it is not only a question of a transformation such as that of one quadruped into another, conserving the generic characters of its ancestor;

but of a transformation of the attitude even, that is to say of morphologic conditions entailing a radical change of type and, indirectly, of physio-psychologic modifications very profound.

The existence of a hiatus between two related living species cannot then serve as argument against the theory of evolution. This hiatus, as we have just seen, may be, on the contrary, a direct result of the transformation of one species into another.

Although the transformation here supposed has been very profound, enough so to give birth to a pretended new *kingdom*, "human kingdom," that transformation could have been produced, according to the above hypothesis, without compelling Nature to make, in any sense, a leap. It may be possible, from a point of view purely zoötaxic, to establish a veritable *saltus*, but I have just shown that this *saltus* could have been the gradual consequence of a simple modification of habits of locomotion in a race of monkeys already capable of assuming the upright position. The motive for this change could have arisen abruptly, but there has been no anatomic leap from Gibbon α to existing man. That which can have been produced abruptly is the exterior condition from which would have resulted, for an anthropoid race of climbers, the necessity of adopting habitually a mode of locomotion which it was already capable of utilizing occasionally. The only thing abrupt, from a biologic point of view, would have been a simple increase in the frequency of the utilization of a functional aptitude already existing. Multiple and considerable anatomic modification may have been entailed by this change of the habitual attitude, but they ought to have been produced by insensible degrees and are all the less astonishing in that the anthropoids already approach much nearer to man than to monkeys proper in their general conformation (Huxley, Broca).

If there is a gap between the existing human species and the precursor, the fossil remains of the intermediate races ought none the less to exist. There ought to be the remains of H° , of gibbon α and of *Prothylobates*. Will these last perhaps reveal a species remarkable in stature and in a relatively superior aptitude for the upright position? That is not necessary theoretically: the diverse species of the genus *Hylobates* have a conformation which enables them to assume the upright position with ease; the form may have undergone considerable variations after the transformation of the attitude.

Finally, it is probable that the species gibbon α approached man in certain respects more than do known species of the genus *Hylobates*.

However, if we admit that the pieces found at Trinil really represent the remains of a *Pithecanthropus*, and if it is admitted

that this was an ancestor of man, it is necessary to find now an ancestor to this *Pithecanthropus*, and it seems requisite that this ancestor be not inferior to existing anthropoids. It must have been capable of adopting, in case of need, the upright position, and been led, by its conformation, to take that attitude rather than the quadruped attitude. Such would be certainly the case with all known anthropoids, all of which are veritable biped *climbers*.

Let us recall here the existence in the Miocene epoch of several anthropoid species such as the *Dryopithecus*, the *Pliopithecus*, and the *Anthropopithecus sivalensis*. As Mr. Dubois has remarked, his species does not lack for ancestry.

The transformation of the habitual mode of locomotion may have been very rapid, but the consecutive, morphologic transformations must have demanded much time and cannot have been fixed hereditarily until after a certain number of generations—hundreds perhaps, and perhaps many less, for selection under the conditions indicated above may have been very active; the two sexes must have contributed actively to the progression, and the young must have imitated their parents with an ever-increasing facility. As regards the *direct* morphologic consequences of the change of attitude, we may suppose they were produced with great rapidity, if we are to judge from the multiple skeletal variations caused in man under the influence of the minimum of functional variations compared with those with which we have to do here.

As regards cerebral increase, it proceeds with such slowness that we can scarcely affirm the fact has been established at all for our European races since prehistoric times. But the cranial capacity of the *Pithecanthropus* surpassed by about 300 grams that of the largest gorillas. It surpassed by at least as much that of its ancestor gibbon *z*, if this latter was of the same stature as the *Pithecanthropus*. There is here an enormous difference, greater than that between the average for our lowest and the average for our highest existing human races. It is not, however, embarrassing for the hypothesis under discussion.

We must consider, in fact, that the human species has never realized, since the beginning of its existence, a progress comparable to that represented by the passage from the state of climber to the state of "marcheur bipède." This passage represents a veritable liberation of the superior members, the hands, previously employed as organs of locomotion the same as the feet. It is by the mode of locomotion of the climber that the hand became, little by little, apt for the function of prehension, then for the function of manipulation, and it is by virtue of the complete emancipation here supposed of the

superior member with reference to locomotion that the functions of prehension and of manipulation of the hand have been able to acquire adaptations the most varied. The perfecting of the tactile sense must have been an immediate result of this emancipation. This result must have involved the acquisition of a multitude of new notions suggesting new movements, new actions. From that, the multiplication of the movements of the fingers and of their combinations, the increase in manual skill and all the psychologic consequences, reacting the one upon the other, which must have been produced necessarily, by increase, in variety and complexity, of newly acquired motive and sensorial representations. On this subject, I could not do better than to refer the reader to the beautiful pages devoted by Herbert Spencer to the parallelism of the sensorial and motor improvement in the animal series together with the intellectual improvement.*

It is impossible to say, even approximately, to what augmentation of cerebral weight the transformation in question may correspond, but there are grounds for believing that this augmentation must have been considerable, all the more so since the intellectual growth in question must have influenced simultaneously the sensorial and motive manifestations, and the order of sensations the psychologic importance of which is extreme, and the order of movements (the movements of the fingers) very numerous and which we know to be of great help in the function of expression. This function is perhaps the most important to be considered here, because its progress reacts in a capital manner upon intellectual and social development. It may have been noticed, among divers savage peoples, how much the language by gesture makes up for the imperfections of the spoken language; it is then allowable to suppose that the movements of the hands and of the fingers figured largely among the primitive means of expression of Pliocene man.

I do not believe it is possible to cite any ulterior cause of psychologic progress and of increase in brain weight comparable to the emancipation of the superior members with which we have just been occupied. The perfecting of articulate language must have been consequently the principal factor supervening in the psychologic and cerebral progress, to which would be due the superiority of the lowest existing races over the *Pithecanthropus*.

The quantitative cerebral progression has been accompanied by an improvement in the general form of the brain. This improvement is already perceptible in the *Pithecanthropus* according to the general form of the skull; it seems, however,

* H. Spencer, Principles of Psychology, vol. i.

to have been about parallel to the quantitative progress from the anthropoid precursor to civilized man. But it is not possible to introduce here this very complex question with the necessary developments.

It would not be absurd to try upon the gibbon an experiment conformable to our hypotheses. Without going so far as to wish to reproduce the formation of a new *Pithecanthropus*, we might attempt to picture what would happen to the attitude in placing the gibbon under conditions favorable to the transformation of its habits of locomotion.

As an intermediate form between man and monkeys, it is difficult to image anything more satisfactory than the skull of Trinil. If this skull, as is probable, is not exceptional for its race, we can count upon finding other specimens approaching still more nearly, either to man or to the monkey. But what the race of Trinil has not yet furnished, have not the lowest human races furnished in abundance? Do there not exist human crania, inferior compared with the average of their race, which show to us all the transitions theoretically desirable between man and the *Pithecanthropus*? All the inferior human crania which it would be possible to show as approaching the form of Trinil by certain characters would make up very well for the absence of the better specimens of the race *Pithecanthropus*. But it will be difficult to find, among normal human skulls, specimens as pithecoïd as that of Trinil. We see frequently in a race such and such individual characters recalling an ancestral type, for it is easier to descend than to ascend in matters of evolution; but the pathologic arrests of development supervening during the embryonic stage only are capable of giving rise to a whole ensemble of characters recalling a remote phase of phylogenic evolution. Microcephalous idiots only, even among the lowest human races, present such an ensemble of characters which come to realize a morphologic type inferior to that of *Pithecanthropus* itself.

The distance existing between the *Pithecanthropus* and normal man must be considered as a necessary result from the point of view of evolution. It is the superior portion of the intermediate race which can have survived and formed an inferior human race. This latter must then present characters superior to the average of its ancestors, even independently of the progress that this human race can have realized since the Pliocene epoch. The existence of human crania presenting at once the ensemble of the cranial characters of *Pithecanthropus* has not yet been demonstrated, unless we take into account the microcephaly more or less accentuated, that is to say, a veritable anomaly by arrest of development. But we cannot represent a race by an abnormal skull, and it will be noted in the present instance that the resemblance existing

between human skulls more or less affected by microcephaly and the skull of Trinil would not contradict the hypothesis according to which this last would represent an ancestral race. This resemblance, on the contrary, would be perfectly conformable to the theory of evolution, and it exists. Without going beyond civilized races, we know that complete microcephaly carries man back to a level with the monkeys. It is then solely the poverty of our collections which has kept us from finding, among the lowest human races, skulls as pithecoïd as that of Trinil. The skulls presented by Sir W. Turner, in his interesting memoir on the subject, approach it only partially. It is the same with the Sambaqui skull which Professor A. Nehring of Berlin has just confronted with that of Trinil.*

Crania approaching more nearly to that from Trinil under the double aspect of form and of capacity will certainly be found, but they will be crania very inferior to the average of their race; they will be the microcephalous, the abnormal.

Nothing would better serve to show that the species of *Pithecanthropus* and the human species penetrate into each other and are mutually bound together. The bond would be still more complete if we should find some day, by virtue of inverse operation, a whole fossil series of the race *Pithecanthropus erectus*, of which the superior extremity would accord morphologically with the average of our lowest races.

To invalidate the legitimate and probable hypothesis of Mr. Dubois, it would be necessary to show that the skull of Trinil is a simple monstrosity without ethnologic signification. This chance would be mathematically possible, since the race of Trinil must have had, as others, its microcephalous individuals; and it is for that reason that the opinion opposed to that of Mr. Dubois can pride itself, until there has been further investigation, in one possibility as against thousands of contrary possibilities. The improbability of a case of submicrocephaly coincident with a stature at least medium seems to me still greater since I have seen the two molars of Trinil, for teeth too large and too long for a normally developed savage would attest, in case of human microcephaly, one more singularity; a microcephaly which would have exaggerated, not only the volume of the teeth with reference to the skull, but also the absolute volume of the teeth beyond the ethnic maximum.

The hypothesis of a case of microcephaly being cast aside, two others remain.

1st. During the Pliocene epoch, there lived in Java a human race intermediate between the lowest of known races and anthropoids.

* Ein *Pithecanthropus*-ähnlicher Menschenschädel, etc. (Naturwissenschaftliche Wochenschrift, 17, Nov. 1895.)

2d. During the Pliocene epoch, there lived in Java an anthropoid race possessing the "marche bipède," and intermediate, in cerebral development, between the highest forms of known monkeys and the human species.

We may fuse these two hypotheses into one, from the point of view of the theory of evolution, that is to say, we may consider with great probability the race in question not only as a race precursor for the human species, but also as a race ancestral, as the commencement of humanity.

That there is in all this much hypothesis, I do not deny. But the attributing of the pieces from Trinil to two or three unknown species closely resembling man, or to a single abnormal specimen of the human species, that is, also, merely hypothesis.

Then, since we are obliged to have recourse, in any case, to a hypothesis, we have to ask which one is the most suitable, not only to explain the facts directly on trial, but also to clear up this question henceforth thrust imperiously before us for examination, namely, what can have been the human species during the Pliocene and how can it have originated? In the presence of the discovery of Mr. Dubois, it is advisable to examine the question in its entirety.

The question does not admit of a mathematical demonstration, but there can be a degree of probability great enough to carry with it conviction. To admit as true, until there is proof to the contrary, a hypothesis which answers to a great number of facts without being contradicted by any, is to act in accordance with the scientific spirit. It has often been said that science does not consist in a heap, but in a chain, of facts. To discover this chain, hypothesis plays a necessary role. Certain zoologists suppose that the human species has had no ancestors. If this hypothesis, of which the probability is not of the first order, seems to them to be scientific and fruitful, the opposite hypothesis can boast of titles to belief at least equal, in our opinion. And if the human species did not appear by spontaneous generation,—if, on the other hand, the cranial characters of Quaternary man found in Europe represented a phase of evolution very little removed from the existing phase, there is cause for believing that there would be found in Pliocene deposits a race morphologically inferior to that of Neanderthal and of Spy. But this is precisely what has happened. The anthropomorphous human race, if you choose to call it so, found by Mr. Dubois, presents characters such that it may have resulted directly and progressively from the transformation of a race of anthropoid climbers. Under these conditions, if the doubt on the subject of the simian origin of Man is only proportionate to the reasons of a scientific order capable of giving rise to it, it seems to me it must be a very slender doubt.

ART. XXV.—*The Titration of Sodium Thiosulphate with Iodic Acid*; by CLAUDE F. WALKER.

[Contributions from the Kent Chemical Laboratory of Yale University—LXV.]

THIS investigation was undertaken to determine the nature and limitations of the reaction between iodic acid and thiosulphuric acid, and to show the expediency of employing iodic acid in standard solution for the direct titration of sodium thiosulphate. Riegler* states that iodic acid is readily obtained in the pure state, that it may be accurately weighed out, and that a solution of it may be exactly made up to a desired strength and kept for a long time unaltered. He further states that when a solution of sodium thiosulphate is titrated with iodic acid the reaction takes place according to the equation,

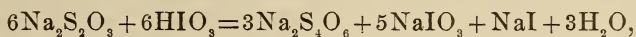

under which circumstances no free iodine will be evolved until all the sodium thiosulphate has been oxidized to tetrathionate; the first drop of iodic acid in excess, however, will react with the sodium iodide that has been formed, and separate iodine, as shown by the equation,

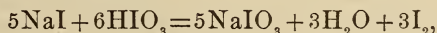

thus furnishing an accurate means for determining the end point.

A careful repetition of the work of Riegler has shown that his conclusions are in a large measure erroneous. Thus, it has been found that the ordinary "chemically pure" iodic acid, purchased from reliable manufacturers, is likely to contain more than the theoretical amount of iodine, due probably to the presence of the anhydride, although iodic acid can be safely employed for standardizing when it is made in the laboratory by dissolving the purified anhydride, crystallizing out the acid, and drying over sulphuric acid. Such a carefully prepared product, if used immediately, will be found to contain the theoretical amount of iodine. Riegler's proposed method of titration depends on two different reactions, and to insure the accuracy of the process these must be definite, complete and non-reversible under the conditions of analysis. Thus one molecule out of every six of iodic acid should be reduced by six molecules of thiosulphate, with the formation of a neutral mixture of iodide and iodate, free from other oxidizing or reducing substances. Under these circumstances it might be expected that iodine will be liberated by the first trace of iodic acid in excess. It has been found by investiga-

* Riegler, *Zeit. für Analyt. Chem.*, xxxv, 308.

tion, however, that although the main reaction between iodic acid and sodium thiosulphate may result in the formation of sodium tetrathionate in the proportions given, there is nevertheless striking evidence of some other obscure action of the thiosulphate, which influences the reduction of the iodic acid in such a way as to make it impossible to calculate the analyses according to Riegler's reaction. Moreover, a peculiar "after-coloration" which invariably follows the first formation of the starch blue during the titration of one solution against the other, seems to point to the possibility that the reaction between the iodide and iodic acid is dependent, under these circumstances, on conditions of time and mass for its completeness. It is not impossible that some third compound of iodine, unstable in its nature, may be formed as an intermediate product and thus delay the liberation of iodine. In consideration of the results that have been obtained it appears that Riegler's proposed process for standardizing sodium thiosulphate, as well as his related method for the analysis of iodides,* must remain impracticable unless they can be modified so as to do away with a number of sources of error.

The analyses of solutions of iodic acid, during the entire course of the work, was invariably performed by adding to the portion of the solution to be analyzed an excess of potassium iodide, acidifying with 5^{cm}³ of dilute (1 : 3) sulphuric acid, and recovering the liberated iodine by directly titrating the acid solution with sodium thiosulphate, or by neutralizing with potassium bicarbonate in excess, and directly titrating the alkaline solution with arsenious acid. In the latter case the neutralization was performed in a trapped Drexel washing bottle such as has been described in connection with the analysis of iodides.† In either case one-sixth of the iodine recovered was calculated to iodic acid, according to the terms of the equation,

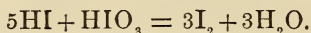

It follows from these proportions that to bring the analyses within the range of the decinormal solutions ordinarily employed, the iodic acid taken for analysis must be restricted to comparatively small amounts. In the present work it was found convenient to analyze the iodic acid in quantities not much exceeding one-tenth of a gram, in which case the variation in the results in the same series is found to be almost inappreciable. In both variations of the process one or two blank analyses were invariably made, by performing the operation as detailed, except that no iodic acid was employed, and the correction of one drop of iodine thereby shown to be necessary to

* Reigler, *Zeitschr für Analyt. Chem.*, xxxv, 305.

† Gooch and Walker, *this Journal*, iii, 293.

bring out the starch blue was uniformly applied in the analytical work.

To determine whether or not the purity of the ordinary iodic acid is sufficient to admit of its direct application in standard solutions, a series of experiments was made. Two different samples of "chemically pure" iodic acid were used. The first was in coarse granular crystals, and the second was in the form of fine powder. Quantities of both of these were dried in a dessicator over sulphuric acid to constant weight. Neither sample lost weight appreciably when left for a considerable time on the scale pan. A third sample of iodic acid was prepared by dissolving a quantity of the purest obtainable iodic anhydride in water, and evaporating at ordinary temperature. The resulting crystalline mass was dried over sulphuric acid in a dessicator for one week, until it ceased to lose weight, when it was presumed to consist of the pure normal acid. Two presumably decinormal solutions of each of the first two samples, and one such solution of the third sample of iodic acid were made by weighing out 17.585 grms. and dissolving in exactly one liter of water at 15° C. Convenient portions of each of these solutions were analyzed in the manner described, with results shown in the following table, averaged from many determinations.

TABLE I.
Analyses of Approximately $\frac{N}{10}$ Iodic Acid.

| Solution analyzed. | Sample used. | HIO ₃ taken. grm. | HIO ₃ found. grm. | Error. grm. |
|--------------------|--------------|---------------------------------|---------------------------------|----------------|
| I | A | 0.1055 | 0.1066 | 0.0011 + |
| II | A | 0.1055 | 0.1062 | 0.0007 + |
| III | B | 0.1055 | 0.1065 | 0.0010 + |
| IV | B | 0.1055 | 0.1073 | 0.0018 + |
| V | C | 0.1055 | 0.1053 | 0.0002 - |

These results show that while the deviation from the theoretical strength of the solution in the case of the acid prepared from the anhydride is hardly appreciable, and will not affect the accuracy of any work in which the solution may be applied as a means of standardization, the solutions made from the purchased product, on the other hand, contain a very appreciable amount of iodine in excess of the theoretical. That iodic acid is somewhat unstable at 30-40° C., gradually losing water with the formation of the anhydride,* is well known, and it is quite possible that to some such gradual change as this must be attributed the fact that the ordinary iodic acid cannot

* Dammer, Anorganische Chemie, i, 564.

be safely employed as a means of standardization unless its purity be directly determined by analysis.

To determine whether a solution of iodic acid, once prepared and standardized, will retain its strength for a long period of time, two such solutions were kept for four months (in the dark) and then again analyzed. The results (averages of several determinations), given in Table II, substantiate the observation of Riegler that a solution of iodic acid will remain of constant strength.

TABLE II.
Constancy of Strength of Iodic Acid Solutions.

| Iodic acid Solution. | First analysis. | Second analysis. | Variation. grm. |
|-------------------------|---------------------------------|--|--------------------|
| | HIO ₃ found. grm. | (after four months) HIO ₃ found. grm. | |
| I | 0.1073 | 0.1072 | 0.0001— |
| II | 0.1049 | 0.1046 | 0.0003— |

An approximately one-twentieth normal solution of "chemically pure" sodium thiosulphate was made and its exact strength ascertained by titrating it with standardized iodine. A series of analyses made by oxidizing the sodium thiosulphate to sulphate, and precipitating and weighing as barium sulphate, gave results identical with those obtained with iodine, proving that all the sulphur present in the solution was in the form of thiosulphate. According to Riegler's equation, sodium thiosulphate and iodic acid react molecule for molecule, and solutions of these substances should therefore require for their mutual saturation volumes inversely proportional to their concentration. It was found, however, that when the one-twentieth normal solution of sodium thiosulphate that has been described was titrated in the presence of starch emulsion with an approximately decinormal solution of iodic acid, prepared from the anhydride, a distinctly blue color was produced long before the theoretical amount of iodic acid had been added. It was further noticed that the end-point of the reaction was far from distinct, a faint tinge of blue at first being visible, then suddenly becoming deeper, and immediately reappearing when bleached with sodium thiosulphate. The deficiency in the amount of iodic acid actually required to produce the blue color was not lessened by titrating only three-fourths of the theoretical amount of iodic acid, and estimating the residual thiosulphate with iodine. It was found, however, that the addition of a considerable quantity of potassium iodide to the solution, either before or during the titration, had the marked effect of making the reaction sharp and distinct, entirely preventing the "after separation" of iodine, at the same time

postponing the appearance of the starch blue until a quantity of iodic acid had been added considerably in excess of the theoretical. These experiments were executed with entirely different reagents, and under varied conditions of concentration, the results in every case exactly confirming those already observed.

For the purpose of more particularly investigating this subject, there were prepared and standardized an approximately decinormal solution of sodium thiosulphate, and an approximately one-fiftieth normal solution of iodic acid. Measured portions of the sodium thiosulphate solution were titrated with the iodic acid in the presence of starch emulsion under varying conditions of mass, time and dilution.

To determine the variability of the end-point of the reaction when the titration was conducted as directed by Riegler, a series of experiments was made. Measured amounts of the sodium thiosulphate solution were drawn from a burette into an Erlenmeyer beaker of suitable capacity, the sides of the beaker were carefully washed down with a small amount of water, 5^{cm}³ of starch emulsion were added, and the iodic acid was slowly dropped into the small bulk of acid and starch, with constant agitation of the mixture, until the first tint of blue coloration appeared. The results obtained are given in Table III.

TABLE III.

Variation of the End Reaction between $\frac{N}{10}$ Sodium Thiosulphate and $\frac{N}{50}$ Iodic Acid, in the absence of Potassium Iodide.

| | Na ₂ S ₂ O ₃ taken. cm ³ . | HIO ₃ introduced. cm ³ . | Mean value. cm ³ . | Variation. cm ³ . |
|-------|---|---|----------------------------------|---------------------------------|
| (1) | 6 | 28·13 | 28·32 | 0·19— |
| (2) | 6 | 27·79 | | 0·53— |
| (3) | 6 | 28·03 | | 0·29— |
| (4) | 6 | 28·32 | | 0·00 |
| (5) | 6 | 28·32 | | 0·00 |
| (6) | 6 | 28·71 | | 0·39+ |
| (7) | 6 | 28·83 | | 0·51+ |
| (8) | 6 | 28·43 | | 0·11+ |
| (9) | 4 | 18·94 | 18·68 | 0·26+ |
| (10) | 4 | 18·67 | | 0·01— |
| (11) | 4 | 18·50 | | 0·18— |
| (12) | 4 | 18·60 | | 0·08— |

These experiments indicate that the constancy of the end reaction in different titrations of equal volumes of the same solution depends to a certain degree on the volume of sodium thiosulphate taken. The results in the case of the maximum amounts vary within a range of 1·04^{cm}³, which corresponds to

0.0035 gram. of iodic acid, while the average variation is 0.25cm^3 , corresponding to 0.0009 gram. The variation in the analyses of the smaller amounts is less, the range being 0.44cm^3 , corresponding to 0.0015 gram., and the average variation being 0.13cm^3 , or 0.0005 gram. The probable error which these irregularities would introduce in any series of practical analyses by this method is obviously greater than can ordinarily be permitted in iodometric work.

The experiments detailed in Table IV were performed exactly similarly to those of the last series except that two grams of potassium iodide were added to the sodium thiosulphate before the titration was commenced.

TABLE IV.

Variation of the End Reaction between $\frac{N}{10}$ Sodium Thiosulphate and $\frac{N}{50}$ Iodic Acid, in the presence of Potassium Iodide.

| | Na ₂ S ₂ O ₃ taken. cm ³ . | HIO ₃ introduced. cm ³ . | Mean value. cm ³ . | Variation. cm ³ . |
|-------|---|---|----------------------------------|---------------------------------|
| (1) | 6 | 32.53 | 32.48 | 0.05 + |
| (2) | 6 | 32.45 | | 0.03 — |
| (3) | 6 | 32.67 | | 0.19 + |
| (4) | 6 | 32.37 | | 0.11 — |
| (5) | 6 | 32.36 | | 0.12 — |
| (6) | 6 | 32.50 | | 0.02 + |
| (7) | 4 | 22.30 | 22.19 | 0.11 + |
| (8) | 4 | 21.98 | | 0.21 — |
| (9) | 4 | 22.17 | | 0.02 — |
| (10) | 4 | 22.30 | | 0.11 + |

These experiments indicate plainly that in the presence of potassium iodide the end reaction of different titrations of equal volumes of the same solution is practically independent of the amount taken for analysis. The results in the case of the maximum amounts vary within a range of 0.31cm^3 , or 0.0011 gram. of iodic acid, while the average variation is 0.09cm^3 , corresponding to 0.0003 gram. The variation in the analyses of the smaller amounts is practically the same as that of the larger, the range being 0.32cm^3 , corresponding to 0.0011 gram., and the average variation being 0.11cm^3 , or 0.0004 gram. It is therefore evident that the presence of potassium iodide in the sodium thiosulphate to be titrated will bring the variation of the formation of the reading tint within permissible limits.

A series of experiments was made to determine the nature and effect of the "after coloration" observed to take place when a solution of sodium thiosulphate, free from potassium iodide, was titrated with iodic acid to blue coloration, and then bleached with sodium thiosulphate. The titrations were per-

formed in the usual manner except that the volume was adjusted just before the addition of the iodic acid, and the iodine that was set free after the formation of the first reading tint was destroyed at fixed intervals with measured amounts of sodium thiosulphate. The results are given in Table V.

TABLE V.

Effect of Dilution and Lapse of Time on the "After Coloration."

| | Na ₂ S ₂ O ₃ taken. cm ³ . | HIO ₃ introduced. cm ³ . | Na ₂ S ₂ O ₃ introduced. cm ³ . | | | | | Volume. cm ³ . | |
|-------|--|--|--|---------|-----------------|-----------------|-------|------------------------------|--------|
| | | | 15 min. | 45 min. | 1 h. 45 min. | 2 h. 45 min. | 20 h. | | Total. |
| (1) | 6 | 27.68 | 0.25 | 0.13 | 0.08 | 0.00 | 0.03 | 0.49 | 50 |
| (2) | 6 | 27.70 | 0.20 | 0.10 | 0.03 | 0.03 | 0.03 | 0.39 | 50 |
| (3) | 6 | 28.17 | 0.16 | 0.10 | 0.03 | 0.01 | none. | 0.30 | 50 |
| (4) | 6 | 27.03 | 0.60 | 0.26 | 0.09 | 0.03 | none. | 0.98 | 150 |
| (5) | 6 | 27.60 | 0.93 | 0.28 | 0.06 | 0.04 | 0.04 | 1.35 | 150 |
| (6) | 6 | 28.60 | 1.34 | 0.46 | 0.17 | 0.03 | 0.14 | 2.14 | 200 |
| (7) | 6 | 28.85 | 1.20 | 0.50 | 0.28 | 0.06 | 0.27 | 2.31 | 200 |
| (8) | 6 | 31.63 | 1.46 | 0.74 | 0.10 | 0.21 | 0.23 | 2.74 | 250 |
| (9) | 6 | 29.90 | 1.04 | 0.60 | 0.23 | 0.15 | 0.46 | 2.48 | 250 |
| (10) | 6 | 36.09 | 1.60 | 1.23 | 0.63 | 0.34 | 0.18 | 3.98 | 300 |
| (11) | 6 | 37.59 | 1.65 | 1.33 | 0.72 | 0.27 | 0.10 | 4.07 | 300 |
| (12) | 6 | 37.23 | 1.92 | 1.05 | 0.64 | 0.33 | * | 300 | |

In the experiments with small volumes the evolution of iodine in any considerable quantity ceased after two or three hours, although the solution would become recolored as often as it was bleached for a number of days. The traces of iodine thus set free, however, were seldom equivalent to more than one or two drops of sodium thiosulphate. The larger volumes, however, continued to separate iodine in abundance for a very long time. The amount of iodine thus liberated after the first coloration evidently varies with the amount of iodic acid required for the titration, although not strictly proportional to it. Both of these quantities increase at a regular rate with the volume of the solution.

To show with what accuracy the reaction between sodium thiosulphate and iodic acid may be applied to the direct estimation of one of these substances by the other, the averaged results of a large number of titrations are compared in Table VI. The operations were conducted as directed by Riegler, equal measured volumes of standardized sodium thiosulphate being titrated with iodic acid of known strength, in the presence of starch and under different conditions of time, dilution and mass, the volume of iodic acid required to produce the blue coloration being in each case compared with the volume theoretically required by the terms of Riegler's equation.

* No observation.

TABLE VI.

Titration of $\frac{N}{10}$ Sodium Thiosulphate with $\frac{N}{50}$ Iodic Acid.

| | Na ₂ S ₂ O ₃ taken. cm ³ . | HIO ₃ introduced. cm ³ . | HIO ₃ required by theory. cm ³ . | Error. cm ³ . | Error. per cent. | KI present. grm. | Volume. cm ³ . |
|------|--|--|---|-----------------------------|---------------------|------------------------|------------------------------|
| (1) | 4 | 18·68 | 20·32 | 1·64— | 8·0— | — | 50 |
| (2) | 6 | 28·32 | 30·48 | 2·16— | 7·0— | — | 50 |
| (3) | 6 | 27·32 | 30·48 | 3·16— | 7·0— | — | 150 |
| (4) | 6 | * 28·73 | 30·48 | 1·75— | 6·0— | — | 200 |
| (5) | 6 | 30·77 | 30·48 | 0·29+ | 0·01+ | — | 250 |
| (6) | 6 | 36·97 | 30·48 | 6·49+ | 21·0+ | — | 300 |
| (7) | 6 | 27·46 | 30·48 | 3·02— | 10·0— | — | 50 |
| (8) | 6 | 26·15 | 30·48 | 4·33— | 14·0— | — | 150 |
| (9) | 6 | † 26·50 | 30·48 | 3·98— | 13·0— | — | 200 |
| (10) | 6 | 27·16 | 30·48 | 3·32— | 10·0— | — | 250 |
| (11) | 6 | 32·93 | 30·48 | 2·45+ | 8·0+ | — | 300 |
| (12) | 4 | * 22·19 | 20·32 | 1·87+ | 9·0+ | 0·2 | 50 |
| (13) | 6 | 32·48 | 30·48 | 2·00+ | 7·0+ | 0·2 | 50 |

These results show plainly that the amount of iodic acid required to decompose a given amount of sodium thiosulphate may be considerably above or below that required by the terms of Riegler's equation. Thus, with small volumes, and in the absence of potassium iodide, the thiosulphate is destroyed and the separation of iodine commences when only 93 per cent of the theoretical amount of acid has been titrated. At higher dilutions the action is retarded, so that at 250^{cm³} very nearly the theoretical amount of acid is required to produce the first blue color, and at 300^{cm³} an excess of 21 per cent over the theoretical amount must be added. If the "after separation" of iodine is considered to be a measure of the excess of iodic acid, and if its amount is accordingly applied as a correction, it appears that for all volumes below 300^{cm³} the original thiosulphate is completely destroyed when about 90 per cent of the theoretical amount of iodic acid has been added. The presence of potassium iodide in the system retards the action, so that at small volumes an excess of about 8 per cent of iodic acid must be added to completely destroy the thiosulphate and commence the separation of iodine. It is obvious from the preceding experiments that the reaction between iodic acid and sodium thiosulphate is so indefinite in its nature, and so dependent for its completeness on conditions of time, dilution and mass, that its direct application as a means of standardizing solutions must remain impracticable.

The author is indebted to Professor F. A. Gooch for many valuable suggestions during the course of this investigation.

* HIO₃ added to first blue color.

† Calculated by subtracting from the amount of iodic acid originally titrated, the volume of thiosulphate of equal strength required to bleach the solution after standing twenty hours.

ART. XXVI.—*Solarization effects in Röntgen Ray Photographs*; by W. M. LISPENARD ROBB. (With Plates VIII–X.)

It has long been well known, that in photographing with ordinary light, in cases of over-exposure, the picture upon development may be a positive instead of a negative. This phenomenon is known as solarization, as it is usually produced by over-exposure in strong sunlight. Also, in case of over-exposures not sufficiently long to produce a reversal of the image, the photographic plate may be so affected as to prevent satisfactory development.

Some experiments that I have recently made show that similar effects are produced by the Röntgen rays, and that they have a very important bearing upon the distinctness of photographs taken with these rays, and offer a very simple explanation of the halos that so often appear in such photographs.

The following apparatus was used in these experiments: The induction coil used was a "Thompson Inductorium" as manufactured by the General Electric Co., except that a rotary break was substituted for the one furnished with the coil. The rotary break consisted of a solid brass ring 25^{cm} in diameter and 5^{cm} thick. Two slate quadrants, 2.5^{cm} thick, were counter-sunk in the ring. Two copper brushes were arranged so that one was always in contact with the brass and the other alternately with the brass and slate sectors. The ring was mounted on the shaft of a 1 h. p. motor, making 1800 revolutions per minute, and consequently the primary circuit of the induction coil was made and broken 3600 times per minute. A condenser having a capacity of six microfarads was connected with the two brushes. This was the largest condenser available; and it was found that the sparking at the brush, where the circuit was alternately made and broken, was very great, being sufficient to cause great unsteadiness in the illumination of the screen of a fluoroscope. A very simple method was found for overcoming this unsteadiness. A third brush made of mica was placed so as to be in contact with the break and to form an obtuse angle with the brush at which the sparking occurred. This additional brush prevented the sparking; and after it was adopted, the illumination of the fluorescent screen was entirely free from flickering. The current in the primary was adjusted in the following experiments so that the coil would give a spark 25^{cm} long. Single focus vacuum tubes were used. The tubes were spherical in form, about 14^{cm} in diameter, and the distance between the anode and cathode was about 8^{cm}. The tubes used were made by Green & Bauer of Hartford, Con-

necticut, and by the General Electric Co. at their lamp works at Harrison, N. J. In the absence of any exact method of expressing for any given set of apparatus its power of producing Röntgen rays, the statement that the photograph of a portion of a hand reproduced in Plate VIII, fig. 1, was taken with the apparatus just described, will serve to show its character. The time of exposure was 5 seconds and the distance of the hand from the anode 25^{cm}.

Solarization effects were first noticed by the author in connection with the halos surrounding the Röntgen ray photographs of pieces of metal. These halos were in general similar to that shown in Plate VIII, fig. 2, which is a reproduction of the photograph of an aluminum cube, the edge of which was 2.5^{cm}. Surrounding the portion of the photographic plate directly under the cube is a band in which the plate was somewhat affected by the rays. Just outside of this first band is a second one, in which the effect upon the photographic plate was greater than upon any other part of the plate. This halo is easily explained when we consider that in a single focus tube the Röntgen rays come from a considerable area of the anode and that consequently the shadow of the object is surrounded by a penumbra in which the intensity of the radiation increases from the object outward. If the exposure is sufficient to produce solarization, we should have a band in the penumbra where the effect upon the photographic plate would be a maximum exceeding even the effect upon the part of the plate entirely beyond the shadow. The photograph reproduced in Plate VIII, fig. 2, was taken with fifteen minutes' exposure at a distance of 15^{cm}.

The experiment was repeated with cubes of iron, copper, paraffin, and glass, all of which gave similar halos. In general, the image on the photographic plate was visible to the eye before being placed in the developer—a phenomenon that accompanies solarization when produced by ordinary light.

The following experiments were made in order to prove the correctness of the above explanation and to demonstrate the possibility of a photographic plate becoming solarized by the Röntgen rays.

Portions of several plates were covered with pieces of commercial tinfoil and then exposed in succession for different times to the action of the Röntgen rays. It was found that with short exposures a negative was obtained, and with long exposures the image was reversed; the long exposed plates giving a positive when developed. Plate IX, figs. 1 and 2, and Plate X, fig. 1, are reproductions of photographs obtained when a portion of the photographic plate was covered with one layer of commercial tinfoil about 5^{cm} square and 0.0015^{cm} thick, and

the central portion of this layer was covered with thirty-two additional layers of the same foil about 2.8^{cm} square. Plate IX, fig. 1, shows the result when the plate was exposed for 2.5 minutes; fig. 2, when exposed for 5 minutes, and Plate X, fig. 1, when exposed for 15 minutes. These photographs show that with a short exposure, the portion of the plate covered with a single layer of tin-foil was less affected than the uncovered portion of the plate. When the time of exposure was increased, the shadow of the single layer of tin-foil would only be noticed on the negative by careful inspection, and might easily escape detection. In the case of the longest exposure, where the portion of the plate covered with the single layer of the tin-foil is most affected, we have a reversal of the image and a clear case of solarization.

Experiments were also made with photographic plates partially covered with an aluminum cone having an altitude of 1.25^{cm} and a base 5^{cm} in diameter. When the exposure was short, the uncovered portion of the plate was most affected. When the plate was placed at a distance of 15^{cm} and exposed for 5 minutes, the effect reproduced in Plate X, fig. 2, was obtained. In this case, the portion of the plate under the edge of the cone was most affected. When the time of exposure was increased to 15 minutes, all of the plate covered by the cone was affected more than the uncovered portion, and again we have a reversal of the image and a clear case of solarization.

Seed, Kramer crown, and Carbutts' special X-ray plates, and various developers were tried and found to give similar results. Carbutts' X-ray plates and Carbutts' tabloids for developer were used in making the photographs for the accompanying illustrations.

These experiments seem to prove conclusively the possibility of photographic plates becoming solarized by Röntgen rays. This is interesting as adding one more to the properties possessed in common by these rays and ordinary light. Solarization offers a simple explanation of many of the halo effects observed in Röntgen ray photographs. The most important conclusion to be derived from these experiments is the necessity of carefully timing exposures if we are to obtain good contrasts, much of the indistinctness in Röntgen ray photographs being due to over-exposure rather than to under-exposure.

I desire to express my obligation to Columbia University for the very material assistance given me in carrying on these experiments by placing at my disposal the income of the Barnard Fellowship.

Jarvis Physical Laboratory, Trinity College,
Hartford, Conn., July 24th, 1897.

AM. JOUR. SCI.—FOURTH SERIES, VOL. IV, No. 21.—SEPT., 1897.

ART. XXVII.—*The Cape Fairweather Beds; a new marine Tertiary Horizon in Southern Patagonia; by J. B. HATCHER.*

IN July, 1896, the writer discovered near Cape Fairweather, in south latitude about $51^{\circ} 31'$, a series of marine beds with a fairly abundant invertebrate fauna, overlying the fresh water Santa Cruzian beds, which are well represented in this vicinity and contain abundant remains of fossil mammals. It is proposed to call these deposits the Cape Fairweather beds from the name of the cape near which they were first observed.

Going north along the shore, from the mouth of the Gallegos river, the Cape Fairweather beds are first seen at a distance of about two and a half miles, capping the summit of a high tableland on the north side of a rather deep cañon, which empties into the sea from the west. From this point these beds were traced six or eight miles farther north, along the bluffs of the coast; and were seen to extend for some distance westward into the interior, constituting the summit of the higher tablelands. In most places, where present, they are easily recognized by the remains of a large oyster, fragments of which may be seen in great abundance near the summit of the more precipitous bluffs in this vicinity. They are best represented on Rudd's farm, but are also to be seen on the bluff southeast of Mr. José Monte's farmhouse, some six miles inland, though not well displayed.

The Cape Fairweather beds have been deposited upon the eroded surface of the Santa Cruzian beds, as shown by the accompanying section, which was drawn from a sketch made in the field, and represents very accurately the section of the two series of strata on the north side of the cañon above referred to from the top of the tableland, which is reached at *z*, to the level of high tide represented by the line *a—b*. The bluff here, as almost everywhere along this coast, is quite perpendicular, and the color, composition and relations of the various strata are easily seen. The irregular line *c—d* is the line of contact between the two series of beds and shows well the eroded surface of the lower series upon which the upper beds were deposited.

These new marine deposits are of no very great thickness, so far as observed, only 30 to 40 feet. They consist below of a fine-grained, incoherent sandstone; and above, of a rather coarse, usually loose, but in places, extremely hard conglomerate which passes insensibly into the overlying great Patagonian Shingle formation, from which it can only be distin-

guished by the fossils it contains. Both the sandstones and conglomerates are fairly continuous, but the latter are frequently intruded into the former, and the sandstones sometimes entirely replace the conglomerates. In both, marine invertebrates are quite abundant, and according to Professor Henry A. Pilsbry they point to a Pliocene age for the beds.

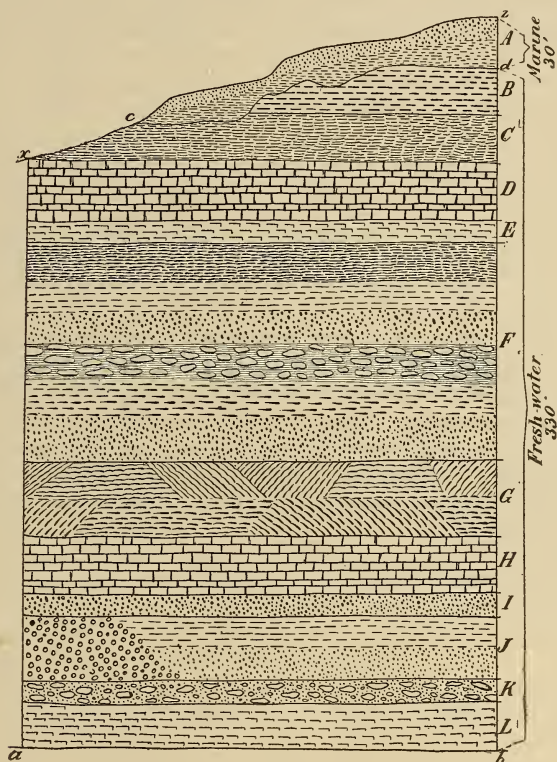

These beds are of interest as being the first instance of a marine formation overlying the fresh water Santa Cruzian formation, in regard to the age of which there has been so much doubt; unfortunately, however, they promise to be of little service in determining the age of the latter. It is quite probable that they may aid in correlating certain marine beds of Parana, discovered long ago and referred by Darwin, D'Orbigny and others to the Patagonian beds, but now known to be of much more recent origin. At present I believe them the equivalent of those beds discovered by Darwin in northeastern Tierra del Fuego and provisionally referred by him to the mammalian beds (Santa Cruzian beds)

discovered by Captain Fitzroy at the mouth of the Gallegos river and believed by Darwin to be more recent than the Patagonian beds. As evidence in favor of correlating the Cape Fairweather beds with those reported by Darwin in Tierra del Fuego, I may mention that in the former there are fragments of crab legs very similar to those found in the bluffs of San Sebastian bay; also the fact that all the Tertiary strata in this region dip very gently to the southeast, so that in going from north to south along the coast the different horizons appear at the level of the sea in chronological order. Near the Mt. of Observation, south of the Santa Cruz river, we find at sea level and for some distance above the Patagonian beds overlaid by the Santa Cruzian beds. Farther south, at Coy inlet, the Patagonian beds entirely disappear under the sea, and the Santa Cruzian beds are at the water level, and still farther south at Cape Fairweather they are overlaid by the Cape Fairweather beds; while at San Sebastian bay on the east coast of Tierra del Fuego the Santa Cruzian beds have disappeared below the sea and the Cape Fairweather beds alone are represented. A study of the Cape Fairweather beds may also afford important evidence as to the origin of the numerous salt water lakes in southern Patagonia; and as to the age, origin and distribution of the great Shingle formation of this region. These and other questions will be considered in a more exhaustive paper on the general geology of the country visited.

Princeton University, Aug. 2, 1897.

SCIENTIFIC INTELLIGENCE.

I. NATURAL HISTORY.

1. The *New Series of Contributions from the Gray Herbarium of Harvard University, No. XI*, by Mr. J. M. GREENMAN, deals with the Mexican and Central American species of *Houstonia*, being a revision of these. It contains also a Key to the Mexican species of *Liabum*, and Descriptions of more than forty new or little known plants from Mexico. Two new genera are added.

G. L. G.

2. *Synoptical Flora of North America*, Vol. 1, Part I, Fascicle II, contains critical descriptions of the North American species from *Caryophyllaceæ* to the *Polygalaceæ*; by ASA GRAY, LL.D., continued and edited by BENJAMIN LINCOLN ROBINSON, Ph.D., Curator of the Gray Herbarium of Harvard University, with the collaboration of WILLIAM TRELEASE, Sc.D., Director of the Missouri Botanical Garden; JOHN M. COULTER, Ph.D., Professor of Botany in the University of Chicago; and L. H. BAILEY, M.Sc., Professor of Horticulture in Cornell University.

A succinct statement which accompanies this welcome publication, shows exactly how the work stands at present. From this we learn that "of the Synoptical Flora, Professor Gray published in 1878 and 1884, two parts including all the Gamopetalous Orders. These parts were reissued by the Smithsonian Institution in 1886, and amount to nearly 1000 imperial octavo pages. For some time before his death Professor Gray, continuing the work, was engaged in monographing the earlier Polypetalous Orders. After the death of Professor Gray the preparation of the Synoptical Flora was carried on by Dr. Sereno Watson, and then by his successor, Dr. B. L. Robinson.

"Following the original plan of the Flora, the treatment of the Polypetalous Orders will form, when completed, Volume I, Part I. Of this portion of the work the first fascicle, comprising the seventeen Orders from Ranunculaceæ to Frankeniaceæ, inclusive, was issued Oct. 10, 1895. The second fascicle now before us carries the work up to Polygalaceæ, and a third, to include the Leguminosæ, is now in preparation by Dr. Robinson."

Botanists appreciate sincerely the careful work which characterizes this joint treatise. Dr. Robinson has spared no pains to keep the Flora on the high plane of Professor Gray's critical investigations, and he has received valuable aid from his distinguished collaborators. We think that the editor has been wise in adhering to the lines laid down by his predecessors. The limitations are here and there occasionally felt perhaps to be rather too strict, but the result has been on the whole far more satisfactory than would have been a complete or even partial overturn. Dr. Robinson and his coadjutors are carrying out the plan in a manner which must commend itself to all who know the circumstances of the case.

G. L. G.

3. *An Illustrated Flora of the Northern United States, Canada, and the British Possessions*, from Newfoundland to the Parallel of the Southern Boundary of Virginia; and from the Atlantic Ocean westward to the 102d Meridian; by NATHANIEL LORD BRITTON, Ph.D., Emeritus Professor of Botany in Columbia University, and Director in Chief of the New York Botanical Garden, and Hon. ADDISON BROWN, President of the Torrey Botanical Club. The descriptive text chiefly prepared by Professor Britton, with the assistance of specialists in several groups; the figures also drawn under his supervision. In three volumes. Vol. II. Portulacaceæ to Menyanthaceæ. Portulaca to Buckbean. Charles Scribner's Sons. 1897.

The first volume of this work has been already noticed in this Journal. To what was then said, nothing need now be added in regard to the second volume, except further congratulations to the authors on their success in giving to Botanists a useful treatise at a very reasonable price. They maintain in the present volume the high character of typographical execution which made the first volume so attractive. The work is progressing steadily; the final volume being promised for early winter. G. L. G.

4. *Guide to the Genera and Classification of the North American Orthoptera found north of Mexico*; by SAMUEL H. SCUDDER. (Cambridge, Edw. H. Wheeler), pp. 1-89, 1897.—This convenient little set of tables for the identification of Orthoptera was prepared for the use of students, and is but preliminary to a fuller general work on the classification of the group. Although containing references only to data already published or about to be published, the tables include nearly two hundred genera.

5. *Das Tierreich. Eine Zusammenstellung und Kennzeichnung der rezenten Tierformen. 1 Lief. Aves. Redakt., A. Reichenow. Podargidæ, Caprimulgidæ u. Macropterygidæ*; bearb. von ERNST HARTERT, pp. 1-98, figs. 1-16. Berlin, 1897. (R. Friedländer & Sohn.)

II. MISCELLANEOUS SCIENTIFIC INTELLIGENCE.

1. *American Association for the Advancement of Science.*—The forty-sixth meeting of the American Association was held at Detroit, from August 9 to 14. The President of the meeting was Dr. Wolcott Gibbs of Newport. The senior vice-president, Prof. Theodore Gill of Washington, who took the place of the retiring president, the late Prof. E. D. Cope, delivered an able address upon Prof. Cope's life and work. Addresses were also delivered by the vice-presidents of the several sections. Nearly three hundred members and associates were in attendance. The list of papers was considerably larger than at the last meeting. The fact that the British Association was to assemble at Toronto on August 18 gave especial interest to the occasion.

The place selected for the next meeting of the Association—its fiftieth anniversary—is Boston and Prof. F. W. Putnam was

elected President. The Vice-Presidents chosen for the several sections are as follows: Section A, E. E. Barnard, of Chicago; Section B, Frank P. Whitman, of Cleveland; Section C, Edgar F. Smith, of Philadelphia; Section D, M. E. Cooley, of Ann Arbor; Section E, H. L. Fairchild, of Rochester; Section F, A. S. Packard, of Providence; Section G, W. G. Farlow, of Cambridge; Section H, J. McKeen Cattell, of New York City; Section I, Archibald Blue, of Toronto. Mr. L. O. Howard, of Washington, D. C., was elected Permanent Secretary.

The following is a list of the papers accepted for reading :

SECTION A. *Mathematics and Astronomy.*

R. S. WOODWARD: Modification of Eulerian cycle due to inequality of the equatorial moments of inertia of the earth. Integrations of the equations of rotation of a non-rigid mass for the case of equal principal moments of inertia.

A. MACFARLANE: A new method of solving certain differential equations that occur in mathematical physics. The theory of quadratic equations.

T. H. SAFFORD: Psychology of the personal equation.

G. A. MILLER: The simple isomorphism of a substitution group into itself.

ARTEMAS MARTIN: On rational right triangles. No. I.

VIRGIL SNYDER: Condition that the line common to $n-1$ planes in an x -space may lie on a given quadric surface in the same space.

J. B. SHAW: Communicative metrics.

H. B. NEWTON: Continuous groups of spherical transformations in space.

A. G. GREENHILL: Stereoscopic views of spherical catenaries and gyroscopic curves.

F. H. BIGELOW: The importance of adopting standard systems of notation and coordinates in mathematics and physics.

L. A. BAUER: On the secular motion of the earth's magnetic axis. Simple expressions for the diurnal range of the magnetic declination.

R. D. BOHANNAN: Remarkable complete quadrilateral among the Pascal lines of an inscribed six-point of a conic.

J. W. GLOVER: General theorems concerning a certain case of functions deduced from the properties of the Newtonian potential function.

W. H. METZLER: Compound determinants.

W. S. AUCHINCLOSS: Waters within the earth, and laws of rainfall.

E. O. LOVETT: The theory of perturbations and Lie's theory of contact transformations.

JAMES MCMAHON: Some results in integration expressed by the elliptic integrals.

W. F. DURAND: The treatment of differential equations by approximate methods.

SECTION B. *Physics.*

F. P. WHITMAN and MARY C. NOYES: Effect of heat on the elastic limit and ultimate strength of copper wire.

A. L. FOLEY: Arc spectra.

C. F. BRUSH: Transmission of radiant heat by gases at varying pressures. Measurement of small gaseous pressures.

D. C. MILLER: Electrical conductivity of certain specimens of sheet glass with reference to their fitness for use in static generators.

W. A. ROGERS: Final determination of the relative lengths of the Imperial yard of Great Britain and the *mètre des archives*.

S. J. BARNETT: Influence of time and temperature on the absolute rigidity of quartz fibers.

C. D. CHILD: Discharge of electrified bodies by X-rays.

F. P. WHITMAN: On the brightness of pigmented surfaces under various sources of illumination.

- H. S. CARHART: The design, construction and test of a 1250-Watt transformer.
 K. E. GUTHE: Electrolytic action in a condenser.
 H. T. EDDY: Graphical treatment of alternating currents in branch circuits in cases of variable frequency.
 A. MACFARLANE: On simple non-alternating currents.
 L. A. BAUER: Magnetic survey of Maryland
 R. L. LITCH: New method of determining the specific heat of liquids.
 G. L. MOLER and F. BEDELL: Instruments for determining the frequency of an alternating current.
 W. J. HUMPHREYS: Effect of pressure on the wave-lengths of the lines of the emission spectra of the elements.
 C. L. NORTON: New form of coal calorimeter.
 C. R. CROSS: Notes on the recent history of musical pitch in the U. S.
 F. A. LAWS: New form of harmonic analyzer.
 N. E. DORSEY: Determination of the surface tension of water, and of certain aqueous solutions, by means of the method of ripples.
 F. H. BIGELOW: Series of international cloud observations made by the U. S. Weather Bureau, and their relation to meteorological problems.
 C. F. MARVIN: Kites and their use by the Weather Bureau in explorations of the upper air.
 B. B. BRACKETT: Effects of tension and quality of the metal upon the changes in length produced in iron wires by magnetization.
 E. W. MORLEY and D. C. MILLER: On the coefficient of expansion of certain gases.
 E. F. NICHOLS: Note on the construction of a sensitive radiometer.
 E. L. NICHOLS and E. MERRITT: Photograph of manometric flames.
 G. W. PATTERSON, JR.: Electrostatic capacity of a two-wire cable.
 C. P. STEINMETZ: Screening effect of induced currents in solid magnetic bodies in an alternating field.
 CARL BARUS: Rate at which hot glass absorbs superheated water. Method of obtaining capillary canals of specified diameter.
 F. BEDELL, R. E. CHANDLER and R. H. SHERWOOD, JR.: Predetermination of transformer regulation.
 W. R. WHITNEY: An electrical thermostat.
 W. O. ATWATER and E. B. ROSA: Apparatus for testing the law of conservation of energy in the human body.
 E. B. ROSA and A. W. SMITH: Electrical resonance and dielectric hysteresis.
 MARGARET E. MALTBY: Method for the determination of the period of electrical oscillations and other applications of the same.
 C. P. MATTHEWS: Two methods of measuring mean horizontal candle power.

SECTION C. *Chemistry.*

- A. B. PRESCOTT: Alkyl bismuth iodides. Kola tannin.
 J. U. NEF: Chemistry of methylene.
 P. C. FREER: Action of sodium on methylpropylketon and on acetophenon. Constitution of some hydrazones.
 A. W. BURWELL: Decomposition of heptane and octane at high temperatures.
 F. J. POND and F. F. BEERS: Derivatives of euganol.
 E. W. MORLEY: Determination of the volatility of phosphorus pentoxide.
 L. M. DENNIS: Recent progress in analytical chemistry. New form of discharge for spark spectra of solutions.
 A. L. GREEN: Qualitative analysis: a point in teaching that was not a full success.
 ELLEN H. RICHARDS: A new color standard for use in water analysis. Contributions from the laboratory of water analysis.
 L. M. DENNIS and C. G. EDGAR: Comparison of methods of determining carbon dioxide and carbon monoxide.
 E. D. CAMPBELL and F. THOMPSON: Preliminary thermo-chemical study of iron and steel.
 E. D. CAMPBELL and S. C. BABCOCK: Influence of heat treatment and carbon upon the solubility of phosphorus in steel.

- E. H. S. BAILEY: Chemical composition of cement plaster.
E. A. DEBAR: Decomposition of halogen-substituted acetic acids.
H. POOLE: Determination of fat and casein in feces.
C. BASKERVILLE and F. W. MILLER: Reactions between mercury and concentrated sulphuric acid.
HARRY SNYDER: Position in the periodic law of the important elements found in plant and animal bodies.
L. KAHLBERG and A. T. LINCOLN: Solutions of silicates of the alkalis.
H. P. CADY and E. H. S. BAILEY: Electrical conductivity and electrolysis of certain substances dissolved in liquid ammonia.
A. A. NOYES and W. R. WHITNEY: The rate of solution of solid substances in their own solutions.
W. R. WHITNEY: Stereometric measurement of the velocity of a reaction.
R. C. KEDZIE: Some contributions to methods of testing flour.
LEON LABONDE: Distillation in general.
M. D. SOHON: An electrical laboratory stove.
H. W. WILEY: Recent progress in agricultural chemistry.
H. W. WILEY and W. D. BIGELOW: Calculations of calorimetric equivalents of agricultural products from chemical analysis.
W. H. KRUG and H. W. WILEY: Solubility of pentosans.
C. B. COCHRAN: Detection of foreign fats in butter and lard.
F. D. SIMONS: Action of certain bodies on the digestive ferments.
E. A. DE SCHWEINITZ: Bacteriological products of hog cholera and swine plague.
WM. MCMURTRIE: Recent progress in industrial chemistry.
H. C. BOLTON: Annual report on indexing chemical literature.
E. E. EWELL: A continuously revised compendium of chemistry.

SECTION D. Mechanical Science and Engineering.

- W. S. ALDRICH: Development of engineering industries by scientific research.
F. P. SPALDING: The cement laboratory as a field for investigation.
R. C. CARPENTER: Effects of temperature on the strength of steel Properties of aluminum alloys.
F. R. JONES: Theories of some planimeters without the aid of calculus.
D. P. TODD: Engineering conditions connected with the mounting of instruments used in eclipse expeditions.
D. S. JACOBUS: Flue gas analysis in boiler tests.
H. S. CARHART: Universal alternator for laboratory purposes.
W. E. GOLDSBOROUGH: Calculation of energy lost in armature cores.
W. A. ROGERS: Production of X-rays by means of Planté accumulator.
J. B. JOHNSON: Definition of elastic limit for practical purposes.
M. E. COOLEY: New apparatus for testing indicator springs.
W. F. M. GOSS: Effect of spark losses on the efficiency of locomotives.
THOMAS GRAY: Machine for measuring friction under heavy pressures.
J. J. FLATHER: New formula for determining the width of leather-beltting.
Graphical solution of belting problems

SECTION E. Geology and Geography.

- F. W. SIMONDS: The Granite Mountain area of Burnet County, Texas.
W. H. SHERZER: Exposures near Detroit of Helderberg limestones and associated gypsum salt and sandstones.
R. T. HILL: Nomenclature of the Carboniferous formation of Texas.
BAILEY WILLIS: Stratigraphy and structure of the Puget group, Washington.
J. U. UNDEN: The loess as a land deposit.
EDWARD ORTON: Ice-transported boulders in coal seams.
W. S. GRESLEY: Clay-veins vertically intersecting Coal Measures.
J. W. SPENCER: Analogy between declivities of land and submarine valleys. Great changes of level in Mexico and the inter-oceanic connections. An account of the researches relating to the Great Lakes.
H. F. OSBORN: The geological age and fauna of the Huerfano basin in southern Colorado.

- FRANK LEVERETT: Lake Chicago and the Chicago outlet.
 F. B. TAYLOR: The lower abandoned beaches of southeastern Michigan. Some features of the recent geology around Detroit.
 G. K. GILBERT: Recent earth-movements in the Great Lake region.
 H. L. FAIRCHILD: Pre-glacial topography and drainage of central-western New York.
 T. C. CHAMBERLIN: Supplementary hypothesis respecting the origin of the American loess.
 F. H. NEWELL: Progress of hydrographic investigations by the U. S. Geological Survey.
 T. C. HOPKINS: Stylolites.
 W. N. RICE: Suggestion in regard to the theory of volcanoes.
 H. P. PARMELEE: Ores and minerals of Cripple Creek, Colorado.
 R. P. WHITFIELD: Observations on the genus *Barrattia*.
 M. A. VEEDER: Ice jams and what they accomplish in geology.
 A. C. LANE: Notes on the geology of the lower peninsula of Michigan. Lower Carboniferous of Huron County, Michigan.

SECTION F. Zoology.*

- THEODORE GILL: On the relationships of the Nematognaths.
 H. S. OSBORN: Skeletons and restoration of Tertiary Mammalia. Reconstruction of *Phenacodus primevus*. Modifications and variations and the limits of organic selection.
 H. C. OBERHOLSER: Geographical distribution of the golden warblers.
 W. E. HOYLE: Collection of the Cephalopoda from the Albatross expedition.
 B. T. KINGSBURY: Characters of the brains of Nematognaths and Plectospondyls.
 C. S. MINOT: Notes on the embryology of the pig. Harvard embryological collection.
 H. G. HUBBARD: The insect fauna *Cercus giganteus*.
 C. C. NUTTING: Sarcostyles of the Plumularidæ.
 F. M. WEBSTER: Study of the development of *Drasteria erecta*. Brood XVI of *Cicada Septendecim*.
 W. G. JOHNSON: Notes on some little known insects of economic importance.
 P. H. ROLFS: Fungus diseases of the San José scales.
 H. K. KIRKLAND: On the preparation and use of arsenate of lead.
 C. P. GILLETTE: Vernacular names of insects. A successful lantern trap. An unusual outbreak of certain plant-lice in Colorado. The peach-twig borer (*Anarsia lineatella* Zell.).
 C. L. MARLATT: Notes on insecticides.
 F. M. WEBSTER and C. W. MALLY: Insects of the year.
 F. H. CHITTENDEN: The bean-leaf beetle (*Cerotoma trituvata*. Forst.) Notes on certain species of Coleoptera that attack useful plants. On insects that affect asparagus.
 T. D. A. COCKERELL: An experience with Paris green.
 F. W. GODING: *Ledra perdita* versus *Centruchus Liebeckii*.
 J. M. ALDRICH: The pine butterfly of the Pacific Northwest.
 W. B. BARROWS: The present status of the San José scale in Michigan. The malodorous carabid *Nomius pygmaeus*.
 C. L. MARLATT: The peach-twig borer (*Anarsia lineatella*).
 L. O. HOWARD: Temperature experiments as affecting received ideas on the hibernating of injurious insects. A valuable coccid. Additional observations on the parasites of *Orygia leucostigma*. Remarks on the distribution of scale insect parasites.
 PAUL MARCHAL: Notes on injurious insects in France during the season of 1896-7. Notes on injurious insects observed in Algeria and Tunis, in 1896-7.
 N. M. SCHOYON: Notes relating to some of the more important noxious insects in Sweden.
 C. P. LOUNSBURY: Notes on a few injurious insects which have attracted special attention at the Cape of Good Hope during the year.

* Including papers read before the Association of Economic Entomologists.

SECTION G. Botany.

C. A. DAVIS: *Trillium grandiflorum* (Michx.) Salisb.; its variations, normal and teratological.

E. J. DURAND: Discussion of the structural characters of the order *Pezizineæ* of Schroeter.

K. E. WIEGAND: Taxonomic value of fruit characters in the genus *Galium*.

C. E. BESSEY: Report upon the progress of the botanical survey of Nebraska. Some characteristics of the foothill vegetation of western Nebraska. Are the trees receding from the Nebraska plains?

B. T. GALLOWAY: Changes during winter in the perithecia and ascospores of certain *Erysipheæ*. The *Erysipheæ* of North America. A preliminary account of the distribution of the species.

L. R. JONES: Some contributions to the life-history of *Hæmatococcus*.

A. E. WOODS: Bacteriosis of carnations.

E. F. SMITH: Walker's hyacinth bacterium.

G. F. ATKINSON: Notes on some new genera of fungi. Comparison of the pollen of *Pinus*, *Taxus* and *Peltandra*.

C. A. PETERS: Reproductive organs and embryology of *Drosera*.

J. O. SCHLOTTERBECK: Development of some seed coats.

J. H. SCHUETTE: Contributions on wild and cultivated roses of Wisconsin and bordering States.

FANNY E. LANGDON: Morphology of the flower of *Asclepias cornuti*.

BOHUMIL SHIMEK: On the distribution of starch in woody stems.

J. B. POLLOCK: Mechanism of root curvature.

R. H. TRUE and C. G. HUNKEL: The toxic action of phenols on plants.

F. C. NEWCOMBE: Cellulose-ferment.

C. P. HART: Is the characteristic acidity of certain species of the arum family a mechanical or a physiological property or effect?

W. J. BEAL: How plants flee from their enemies.

A. P. ANDERSON: Stomata on the bud-scales of *Abies pectinata*. Comparative anatomy of the normal and diseased organs of *Abies balsamea* (L.) Miller, affected with *Aecidium elatinum* (Alb. et Schwein). New and improved self-registering balance.

C. O. TOWNSEND: Correlation of growth under the influence of injuries.

W. W. ROWLEE and K. E. WIEGAND: The botanical collection of the Cornell Arctic expedition of 1896.

E. F. SMITH: Description of *Bacillus phaseoli* n. sp., with some remarks on related species. On the nature of certain pigments, produced by fungi and bacteria with special reference to that produced by *Bacillus solanacearum*.

D. H. CAMPBELL: Notes on Jamaica.

SECTION H. Anthropology.

ZELIA NUTTALL: Superstitions, beliefs and practices of the ancient Mexicans.

W. MATTHEWS: The study of ceremony.

ANITA NEWCOMB MCGEE: Koreshanity: a latter-day cult.

S. D. PEET: Comparison of Cherokee and European symbolism. Serpent symbols in Nicaragua and Yucatan.

R. J. FLOODY: Origin of the week and holy day among primitive peoples.

STANSBURY HAGAR: Micmac mortuary customs.

F. W. PUTNAM: Recent researches, by George Byron Gordon, on the banks of the Ullva river in Honduras for the Peabody Museum. Early man in the Delaware valley. The Jesup expedition and the Asiatic-American problem.

W. H. HOLMES: Surveys of ancient cities in Mexico. Archaeological researches in the Trenton gravels.

M. H. SAVILLE: Ancient figure of terra cotta from the valley of Mexico. Geographical distribution of a certain kind of pottery in Mexico and Central America. Decoration of the teeth in ancient America.

G. N. KNAPP: On the implement-bearing sand deposits at Trenton, N. J.

H. B. KUMMEL: Implement-bearing sand deposits at Trenton, N. J.

G. F. WRIGHT: Discussion of the relics from the sands deposits on the Lalor farm.

H. C. MERCER: Report of an examination of the trenches dug on the Lalor farm, July 25-29.

THOMAS WILSON: Investigation in the land deposits of the Lalor field. Origin of art as manifested in the work of prehistoric man.

R. D. SALISBURY: Geologic age of the relic-bearing deposits at Trenton, N. J.

F. H. CUSHING: Genesis of implement-making.

H. P. PARMELEE: Prehistoric implements from Charlevoix, Michigan.

W. K. MOREHEAD: An archæologic map of Ohio.

ALICE C. FLETCHER: The import of the totem—a study of the Omaha tribe. Right of adoption as practiced by the Osage tribe

D. C. WORCESTER: The Tagbanuas of the Philippines. The Mangyan of the Philippines.

W. W. TOOKER: The significance of John Eliot's Natick.

A. HRDLICKA: Anthropologic work of New York State pathological institute. Description of an ancient skeleton found in adobe-deposits in the valley of Mexico.

H. I. SMITH: Ethnologic arrangement of archæologic material. Popular anthropology in museums.

LIGHTNER WITMER: Experimental analysis of the relations of rate of movement to certain other mental and physical processes.

J. McK. CATTELL: Statistical study of eminent men.

CARL LUMHOLTZ: Case of trepanning in northwestern Mexico.

O. T. MASON: Artificialization of animals and plants.

SECTION I. *Economic Science and Statistics.*

W. H. HALE: Civil service reform. (1) Conflict with the spoils system in the State of New York. (2) Relation of the system to the question of the State and municipal ownership of the quasi-public works.

MARY FORSTER: The competition of gratuitous workers. Economic position of women.

C. P. HART: Labor restrictions as potent factors in social evolution.

L. IRWELL: Racial determination: The increase of suicide.

HENRY FARQUHAR: Wheat consumption in the United States.

H. W. WILEY: True meaning of the sugar schedule of the new tariff

MARCUS BENJAMIN: Contributions to the development of the meterology by the Smithsonian Institution

I. P. ROBERTS: The promotion of agricultural science.

C. P. GILLETTE: Weights of bees and the loads they carry.

W. R. LAZENBY: Annual growth of forest trees.

C. C. JAMES: The municipal system of Ontario.

ARCHIBALD BLUE: Note on the silver question.

B. W. DECOURCY: The U. S. idea in laying out the public lands and the evils resulting therefrom.

2. *The Transactions of the American Microscopical Society*, volume xviii.—This volume contains the report of the nineteenth annual meeting held at Pittsburgh in August, 1896, and gives in full a large number of papers with the discussions which they called out. The presidential address by A. Clifford Mercer discusses the experimental study of aperture as a factor in microscopic vision, and is accompanied by a series of plates giving reproductions of photomicrographs.

FALL OPENING: SEPT. 4th.



At 2 P. M. on Saturday, September 4th, we shall place on sale a number of very large and fine lots of minerals, among which we would call special attention to the following:

ICELAND ZEOLITES!!

On May 22d one of our collectors sailed from New York for Iceland, and his long trip, taken exclusively for minerals for our Company, has been recently successfully completed, and the large collections which he secured are now in our store. Over 300 choice specimens will be offered to our customers September 4th, as a result of this trip. No such large or magnificent lot of Iceland minerals has ever before crossed the Atlantic; no such fine museum specimens of Iceland Heulandite and Stilbite have ever been seen in this country; no such Scolecites, and but few such Ptilolites, while the wealth of extra fine, cabinet-size specimens of Stilbite and Heulandite will amaze every collector. The small lots of Iceland Zeolites heretofore obtained have only whetted the appetites of collectors for our present magnificent offering.

SPLENDID ENGLISH MINERALS.

Our collector returned home via England and visited all of the important localities in the North of England, buying at the mines and from the miners and local collectors. We may safely claim that our present offering of English minerals has not been equalled for six years. It includes 248 small green and purple Fluorites, many of best quality and some showing water bubbles; 136 groups of pellucid Aragonite crystals, some of them exceedingly fine; 183 Barites of various rich colors, including some of the exquisite blue, most beautifully associated with Calcite, a lot of "shadow" Barites, etc.; 100 cabinet-size specimens of Kidney Ore, of exceptional quality; 167 Specular Iron and Quartz, large and small and thoroughly attractive; 93 gorgeous Scarlet Quartz, all that could be obtained; 120 Bigrigg Mine Calcites, nearly all superior and some surpassingly fine; about 60 richly tinted and very beautiful Stank Mine Calcites; 17 new type, charming milky Calcites; 35 Egremont Twin Calcites, which we will sell at lowest prices ever known; etc., etc.

PORRETTA CAVERNOUS QUARTZ CRYSTALS.

A large and exceedingly fine lot at remarkably low prices,—5c. to 25c.

SIPYLITE, THE RARE NIOBATE OF ERBIA.

By far the finest and largest lot of specimens of this excessively rare mineral we have ever had, and all that are likely ever to be obtained.

GEORGIA RUTILES.

A new and surprisingly fine lot of matrix specimens, showing crystals of unrivalled brilliancy and beauty.

UTAH VARISCITE.

A lot of polished slabs just finished up by the lapidary, embracing many of marvelous beauty.

A SMALL COLLECTION OF JAPANESE MINERALS,

Including Axinite, Ilvaite, Sanukite, Vivianite, Hyalite, Rhodochrosite, Stibnite, Topaz, Orthoclase, Olivine crystals, Andesine crystals, Anorthite crystals, etc.

All of the above, and other Brand New Things at our Fall Opening Sale, September 4th, 2 P. M.

GEO. L. ENGLISH & CO., Mineralogists,

64 East 12th St., New York City.

CONTENTS.

| | Page. |
|--|-------|
| ART. XIX.—Principal Characters of the Protoceratidæ; by O. C. MARSH. Part I. (With Plates II-VII.)..... | 165 |
| XX.—Theory of Singing Flames; by H. V. GILL..... | 177 |
| XXI.—Electrical Discharges in Air; by J. TROWBRIDGE... .. | 190 |
| XXII.—Oscillatory discharge of a large Accumulator; by J. TROWBRIDGE | 194 |
| XXIII.—Jura and Neocomian of Arkansas, Kansas, Okla- homa, New Mexico and Texas; by J. MARCOU..... | 197 |
| XXIV.—Pithecanthropus erectus; by L. MANOUVRIER. Translated by George Grant MacCurdy... .. | 213 |
| XXV.—Titration of Sodium Thiosulphate with Iodic Acid; by C. F. WALKER... .. | 235 |
| XXVI.—Solarization effects in Röntgen Ray Photographs; by W. L. ROBB. (With Plates VIII-X.)..... | 243 |
| XXVII.—Cape Fairweather Beds, a new marine Tertiary Horizon in Southern Patagonia; by J. B. HATCHER ... | 246 |

SCIENTIFIC INTELLIGENCE.

Natural History—New Series of Contributions from the Gray Herbarium of Harvard University. No. XI. J. M. GREENMAN: Synoptical Flora of North America, Vol. 1, Part I, 249.—Illustrated Flora of the Northern United States, Canada, and the British Possessions, N. L. BRITTON and A. BROWN: Guide to the Genera and Classification of the North American Orthoptera found north of Mexico, S. H. SCUDDER: Das Tierreich, E. HARTERT, 250.

Miscellaneous Scientific Intelligence—American Association for the Advancement of Science, 250.—Transactions of the American Microscopical Society, 256.

Established by BENJAMIN SILLIMAN in 1818.

THE
AMERICAN
JOURNAL OF SCIENCE.

EDITOR: EDWARD S. DANA.

ASSOCIATE EDITORS

PROFESSORS GEO. L. GOODALE, JOHN TROWBRIDGE,
H. P. BOWDITCH AND W. G. FARLOW, OF CAMBRIDGE,

PROFESSORS O. C. MARSH, A. E. VERRILL AND H. S.
WILLIAMS, OF NEW HAVEN,

PROFESSOR GEORGE F. BARKER, OF PHILADELPHIA,

PROFESSOR H. A. ROWLAND, OF BALTIMORE,

MR. J. S. DILLER, OF WASHINGTON.

FOURTH SERIES.

VOL. IV—[WHOLE NUMBER, CLIV.]

No. 22.—OCTOBER, 1897.

NEW HAVEN, CONNECTICUT.

1897.

TUTTLE, MOREHOUSE & TAYLOR, PRINTERS, 125 TEMPLE STREET.

Published monthly. Six dollars per year (postage prepaid). \$6.40 to foreign subscribers of countries in the Postal Union. Remittances should be made either by money orders, registered letters, or bank checks.

NOW IN PRESS!

A
COMPLETE CATALOGUE
OF
MINERALS.

Nearly 150 pages with over 40 splendid photo-engravings of new and interesting minerals.

CONTENTS.—I. Recent additions to our stock ; II. Collections of Minerals, both Economic and Scientific ; III. Complete Price List of minerals sold by weight for Chemical and Technical purposes ; IV. Meteorites ; V. Gems and Polished Specimens ; VI. Books, Geol. and Min. ; VII. Supplies ; VIII. Alphabetical Price List of specimens in stock, serving also as index of list following ; IX. General Classification of all known minerals, according to Dana, to which is added an important and valuable supplement, compiled from recent mineralogical literature.

See Sample Plates in Advertising Pages of this
Journal.

X. A Metallic Classification of all important minerals: e. g. under the heading "Cerium"—Silicate.—Cerite, Mosandrite, Johnstrupite, Allanite. Minerals are arranged under sub-headings, in order of the per cent of metal contained. The most complete table of the kind ever published.

Bound in an odd and handsome cover, abounding in the finest examples of the photo-engravers' art, it makes an attractive volume and an invaluable work of reference.

Price, postpaid: Cloth, 50c. Half calf, interleaved, \$1.00. (These figures barely cover cost of paper, binding and postage.) Catalogue of Collections, single specimens, etc., free.

A. E. FOOTE,

WARREN M. FOOTE, Manager.

1317 ARCH STREET,
PHILADELPHIA, PA., U. S. A.

Established 1876.

T H E

AMERICAN JOURNAL OF SCIENCE

[FOURTH SERIES.]

ART. XXVIII.—*Fractional Crystallization of Rocks*; by
GEORGE F. BECKER.

AMONG the phenomena most often appealed to in support of the theory of magmatic segregation or differentiation is the symmetrical arrangement of material in certain dikes and laccolites. This separation seems to me readily explicable in certain cases without resort to the hypothesis of the division of a homogeneous fluid into two or more distinct fluids. I have already called attention to the process in brief terms;* though very well known it has not otherwise been invoked, so far as I am aware, to explain rock differences. If the suggestion has previously been made, it seems time that it should be repeated. If we suppose a dike in cold rock filled with mobile lava which does not overflow, or has ceased to overflow, the mass will be subjected to convection currents, because the liquid near the walls will be cooler than that near the median plane of the dike. A circulation of lava will then take place, the descending flow at the sides being compensated by ascending flow near the central surface. The conditions are roughly represented in the diagram below. If the lava is a homogeneous mixture of two liquids of different fusibility, then the crusts which first form upon the walls will have nearly the same composition as the less fusible partial magma. If one follows mentally a small portion of the liquid in its circulation, it will clearly deposit at each of its early contacts with the growing

* This Journal, vol. iii, 1897, p. 39.

walls a part of its less fusible component, and at each completed revolution it will have a different composition. This composition will always tend towards that which represents the most fusible mixture of the component compounds. When this composition is attained, the magma will no longer undergo change by circulation and partial solidification; and the residual mass will gradually solidify as a uniform material. Unless then the injected magma happened to be a mixture of maximum fusibility, the dike would exhibit a gradation in composition from the sides towards the center. In a very narrow dike solidification might take place before an opportunity was afforded for the complete elimination of the less fusible material; while in wide dikes solidified from mobile magmas one might expect the central sheet to approximate to maximum fusibility.

It is evident that the process of solidification in a laccolite closely resembles that in a dike, particularly if the section of greatest area is not absolutely horizontal. Convection will then be set up and solidification from the walls must tend to the evolution of a residuum of extreme fusibility.

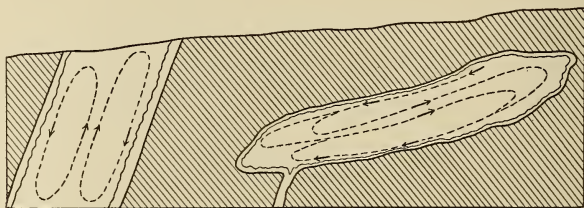

Convection in dikes and laccolites.

The process sketched is one of the most familiar in chemistry and is usually known as fractional crystallization. It has been employed in the purification of compounds ever since chemistry was pursued, and indeed before; for the preparation of salt from sea water or brine depends upon it. It can be and has been employed also to strengthen solutions. A familiar instance is the freezing of weak alcoholic liquids. A bottle of wine or a barrel of cider exposed to a low temperature deposits nearly pure ice on the walls, while a stronger liquor may be tapped from the center. If a still lower temperature were applied the central and more fusible portion would also solidify. Such a mass would be, so far as I can see, a very perfect analogue to a laccolite. A similar concentration is effected in the Pattinson desilverization process.

Though fractional crystallization is said to have been familiar to Paracelsus and even to Aristotle, the process has been studied most thoroughly by Mr. F. Guthrie.* As is well known, he

* *Phil. Mag.* (5), vol. xvii, 1884, p. 462.

names the property of maximum fusibility in mixtures eutectia and the bodies which exhibit this property he calls eutectic. The phenomena are not always so simple as is supposed in the illustration given above, especially when masses, as they approach the temperature of solidification, divide into immiscible fractions. In such cases one has to do with two or more eutectic mixtures. Supersaturation may also intervene to complicate matters and change of pressure probably influences the composition of the eutectics.* Thus it is at least conceivable that very complicated cases should arise, while if the process plays a part in lithogenesis the simplest case is probably the most frequent.

The fractional crystallization process depends essentially upon convection currents. That it is not incompatible with convection is clear, while convection is the mortal enemy of any process of separation involving molecular flow. The only function of diffusion in this case would be to preserve the homogeneity of the residual fluid or mother liquor, so that the eutectic state could not be attained by any sensible part of the fluid until the whole mother liquor was reduced to this condition.

The effect of the solidification of crusts on the walls of a dike or laccolite is to liberate heat. This liberation does not raise the temperature, for otherwise the crusts would remelt; but the liberated heat must be conducted through the walls before the dike as a whole can congeal, and it therefore delays the process of solidification, giving additional time for the evolution of an eutectic magma.

There appear to be some conditions under which eutectic action could not be expected. Unless an intrusive rock possesses considerable mobility, chilling would proceed more rapidly than convection, and eutectic separation would be very imperfect if not completely obscured. Viscosity of the mass would also interfere seriously with the uniformity of composition of the mother liquor. If the mass cooled very slowly indeed, this uniformity might be established even in a very viscous mass; but very slow cooling would also mean very slight convection. In viscous lavas, therefore, fractional crystallization is not very probable. There is seemingly no exact way of defining the degree of viscosity compatible with fractional crystallization, but enough mobility must certainly be present to maintain uniformity in the melted mass when diffusion and convection cooperate. I have shown that, in some solutions at any rate (all for which I could find appropriate experimental data) diffusivity is inversely as the square of viscosity.† If any such law holds for magmas, a moderate amount

* Ostwald, *Allgem. Chemie*, vol. i, 1891, p. 1027.

† *This Journal*, vol. iii, 1897, p. 234.

of viscosity would preclude the formation of eutectic mother liquors.

Eutectic mixtures by definition would have no tendency to fractional crystallization however fluid they might be and however strong the convection currents. Where dikes represent the last remnant of magma in a solidifying mass, one would expect to find them of eutectic composition, as has been pointed out by Mr. J. J. H. Teall.* Convection being needful to fractional crystallization, it would seem essential that the cooling magma should be surrounded by masses of a lower temperature.† In the case of dikes this condition is ordinarily fulfilled. On the other hand, if laccolites ever form and solidify without ejection at great depths and in contact with rocks of high temperature, it seems improbable that convection and partial crystallization would come in play to a sensible extent.

It is difficult to see how so simple and natural a process of solidification as fractional crystallization can fail to be carried out in at least some rocks. Dikes and laccolites assuredly chill from their external surfaces and (barring either an original eutectic composition or insuperable viscosity) there seems no way of avoiding fractional crystallization. It has often been noticed that there is an accord between the order of consolidation of minerals as observed under the microscope and the arrangement of minerals in dikes, the compounds of early secondary crystallization being most abundant near the walls. This is of course what would be expected from a process of fractional crystallization. Observation would no doubt throw further light on the composition of eutectic rock mixtures. Narrow stringers from a so-called "basic" dike would represent the mean composition at the time they were filled; and unless the composition of the magma changed during flow, the stringers should represent the average dike rock. The middle portion of the dike, on the other hand, should tend to display eutexia. Dikes which are homogeneous ought to be eutectic. Many experiments have already been made on eutectic mixtures of salt both in the dry and the wet way. It does not seem impossible that experiments on eutectic mixtures of rock components should give results of an approximation sufficient for the purposes of lithology.

Few, I believe, will maintain that any great progress has been made in explaining the theory of the segregation of magmas into partial magmas. Mr. H. Bäckström,‡ for example,

* *British Petrography*, 1888, p. 401.

† Dr. W. F. Hillebrand reminds me that the changes in density of the mother liquor during crystallization will of themselves induce convection, though perhaps not powerful currents.

‡ *Jour. of Geol.*, vol. i, 1893, p. 773.

denies the applicability of the Ludwig-Soret law. In this he seems to me correct, but I fail to see that he gives adequate reasons for the rejection. He resorts to the separation of magmas into immiscible fractions for a working hypothesis, but without showing how the necessary variations of temperature are to be accounted for. Mr. Alfred Harker* also regards the Ludwig-Soret law as inapplicable to magmatic segregation, which he seeks to explain by the molecular flow attendant upon crystallization. The maximum rate of molecular flow is thus provided for, but I have shown that even under these most favorable circumstances the time required for the separation of considerable masses of material from one another would be practically infinite in any solutions of known properties. Mr. Michel-Lévy again, whose researches in physics give his opinions on the segregation of magmas the greatest weight, has reviewed the hypotheses of Messrs. Brögger and Iddings. He points out the enormous time required for the process and, as others have done, the impeding influence of viscosity. The results of experiment, he thinks, are more favorable to the old theory of superposition of magmas in the order of decreasing density. He finds many objections both to the hypotheses and to the evidence in their favor, and the only point which he regards as certain is that there are some con-sanguineous rocks. These, he thinks, probably came from a reservoir in which the initial magma has undergone only such modifications as were consistent with the preservation of its distinct individuality.† It seems needless to enlarge further on the unsatisfactory condition of the theory of differentiation.

On the other hand, the simple principle of fractional crystallization, which is the very opposite of magmatic differentiation, is in most respects thoroughly well understood, it is known to be practicable by hundreds of thousands of experiments, many of them on a fairly large scale, and its action is so rapid as to bring about in days diversities of composition which it would take centuries to bring about by processes depending on molecular flow. In dikes and laccolites of mobile lavas fractional crystallization seems inevitable, while the convection attending it is inconsistent with segregation by molecular flow. Surely it is worth the while of lithologists to consider in how far differences in such rocks as are beyond a doubt genetically connected can be accounted for by a process which is almost inseparable from consolidation.

Washington, D. C., June, 1897.

* *Quart. Jour. Geol. Soc. London*, vol. 1, 1894, p. 311.

† *Bull. Soc. Geol. de France* (3), vol. xxiv, 1896, p. 123. I should have been glad to reinforce some of the reasoning in a paper printed in this *Journal*, vol. iii, p. 21, by reference to Mr. Michel-Lévy's paper cited above; but it did not come under my eyes in time.

ART. XXIX. — *Eopaleozoic Hot Springs and the Origin of the Pennsylvania Siliceous Oölite*; by GEO. R. WIELAND.

IN seeking for more direct evidence as to the origin of the *siliceous oörites* occurring near the Pennsylvania State College in Center County, Pennsylvania, I have been led to the consideration of certain associated flint bowlders of unusual regularity of structure.

Before describing these, however, it may be well to mention that this siliceous oölite is the most perfect and beautiful of all the oörites, and that its description* was the first given of a characteristic siliceous oölite. Previously several occurrences of cherts merging into oölite had been mentioned. Since then, siliceous oörites of more or less distinct structure, and undoubtedly of various origin, have been reported from widely separated localities, and geological horizons, though none are known to be more recent than the Paleozoic. The cherts of Missouri which often merge into a semi-oölitic structure have been studied by Hovey.*

But the oörites containing a large percentage of silica not only vary much in structure, but much too greatly in composition to prevent any general statement as to their origin. This is shown by the following analyses, made by the writer while a student in the laboratory of the Pennsylvania State College:

| | I. | II. | III. |
|--------------------------------------|--------|-------|--------|
| SiO ₂ | 65·34 | 96·13 | 99·10 |
| Fe ₂ O ₃ | ---- | 1·13 | ·11 |
| Al ₂ O ₃ | ---- | ---- | ·17 |
| CaO | 10·35 | ---- | ·39 |
| MgO | 7·91 | ·97 | -- |
| K ₂ O | ---- | ·58 | -- |
| CO ₂ | 15·24 | -- | -- |
| H ₂ O | 1·85 | ·93 | ·25 |
| | <hr/> | <hr/> | <hr/> |
| | 100·69 | 99·74 | 100·02 |

No. I is an oölite of granular texture, and in fact consists of spherules of silica with a gangue of dolomite. This rock was observed by the writer in a stratum of some twenty feet in thickness near Rockwood, Tennessee. It was only casually examined. A mile away on a lower horizon the iron oölite of the Clinton was being mined. II is from the same locality. III is the remarkably regular spheruled variety from

* Barbour and Torrey: Notes on the Microscopic Structure of Oörites with Analyses, this Journal, September, 1890.

the Pennsylvania State College locality. A smaller spheruled rock occurring in greater quantity contains about a half per cent less of SiO_2 with more iron, alumina and magnesia.

Without attempting to take up the origin of oörites in general, however, I merely mention that two writers working independently of each other have from the microscopic study alone assigned the Pennsylvania oölite as due to direct deposition from the silica-laden waters of hot springs.* This con-

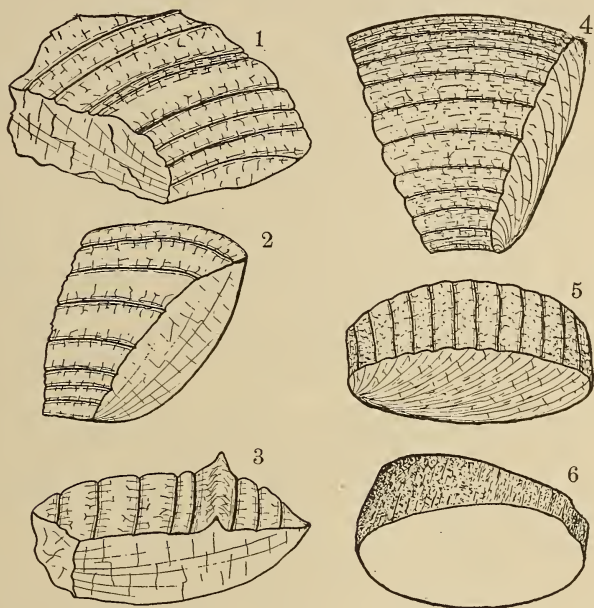

Built-up chalcedony boulders of the Pennsylvania siliceous oölite locality.—
 $\frac{1}{2\frac{1}{2}}$ actual size. Figs. 1, 2, 3, 4, 5, supposed actual rim boulders. Fig. 6, supposed core boulder.

clusion is no doubt correct. A hand specimen found recently consisting of spherules of small size up to pisolitic intermingled with chalcedony-coated pebbles points to its truth.

But probably the most convincing testimony to the existence in the Calciferous of a limited area of hot springs from whose silica-laden waters these siliceous oörites were deposited, lies in the fact that in the limited oölite area and nowhere else in the entire region are found in considerable number boulders of a built-up structure which may have formed the rims of hot springs or geysers. Types are shown in figures 1-6

* E. O. Hovey, *Geol. Soc. of Am.*, vol. v, 1893. Dr. W. Bergt, *Ges. Isis* in Dresden, 1892.

above. The most distinct of these bowlders are found within an area of less than one square mile, and this is exactly the area of the best marked oölite. It should be stated that neither oölite nor bowlders have ever been observed except as surface debris. This may be due to the fact that the oölite probably never formed a very continuous stratum, as well as to the fact that there is neither rock exposure nor excavation within the oölite area. Both bowlders and oölite no doubt belong to the underlying rock, which I suppose from its position and the character of exposures of the same horizon at another point to be Calciferous. There occur associated with the oölite at one or two points, certain bowlders showing only traces of oölite which contain nearly obliterated traces of numerous fossils. I would say that brachiopods, cyathophylloid corals, a gasteropod, and numerous orthoceratites are represented.

The cuts of the bowlders illustrate their form and cleavage fairly, but do not show the pitting of the surface due to weathering. The bowlders are much iron-stained and somewhat granular in texture, though breaking most readily along the cleavage planes which radiate from the inner edge of the circular rims of which they may be regarded as segments. The direction and position of these planes are best shown in figs. 2, 4, and 5. What was probably the upper surface is roughly but regularly grooved, as best shown in fig. 1. These groovings mark more or less nearly the emergence of the cleavage planes just mentioned. The bowlder shown in fig. 6 lacks the built-up structure, and may have formed within an already formed rim. There are occasional small rhombohedral cavities as in the oölite itself,—a pseudomorphism after calcite.

Under the microscope the material is found to be chalcidony, with small crystal inclusions which were too minute to determine. I suspect these crystals to be biaxial, and they may be from their shape hornblende.

The rims which these bowlders formed had an inside diameter of from two to six feet. The inner edge is always preserved, while the outer is often irregular or broken away. We may readily conceive the bowlders as having formed the rims of a number of hot springs or geysers near a low-lying shore of the Calciferous. The dissolved silica first deposited would have formed rings, that deposited while in more rapid motion the small spheruled oölite, which is most plentiful near the best marked of the rim bowlders. Lastly would be formed large grained oölite, the compact and pure quartzite, which is the handsomest oölite known. That in accounting for the origin of this oölite hot springs or geysers of the Calciferous may actually be located is an interesting consideration. While the writer has not had an opportunity to examine a geyser region, he believes that further investigation will sustain his view.

ART. XXX.—*On the Conditions required for attaining Maximum Accuracy in the Determination of Specific Heat by the Method of Mixtures*; by F. L. O. WADSWORTH.

Introductory Note.—In the last volume of the Proceedings of the American Academy, which has just been received at the Observatory, I find a paper by Professor Holman* discussing methods of making the “cooling corrections” in determining specific heat by the method of mixtures. In this paper the author has suggested that this correction may be simplified by a modification of the usual method which “is supposed to be new.” This suggestion is of the same nature as one which I made some years ago and embodied in a paper which formed part of my report in laboratory work at the Ohio State University for 1888–89, but which was never published. The investigation was undertaken as preliminary to an accurate determination of the specific heat of the metal of one of Professor Rogers’ standard bars, a sample of which had been sent to Professor Thomas for that purpose. No opportunity was given at that time to put the suggested method to actual test, as it was subsequently decided to use the ice calorimeter instead.

The method differs from that suggested by Professor Holman in that it goes further and eliminates the necessity for the cooling correction entirely. Except for that part of the paper (pp. 274–277) which deals with the conditions for securing this result, there is nothing novel or particularly original in the treatment. But as the whole discussion is more or less linked together and as it will serve to supplement to some extent Professor Holman’s paper, which deals only with the cooling correction (the most important but not the only source of error in calorimetric determinations), it has been decided to let the paper stand as it was first written (except for a slight rearrangement of the order of the paragraphs), supplementing the original text with footnotes where it seemed necessary. At the end will be found a few general notes relative to the arrangement and use of apparatus in the determination of specific heat by both the method of mixtures and the method of the ice calorimeter. These notes did not form part of the original paper, but have been added from time to time as suggested in my laboratory experience. The method of discharging the hot body from the heating vessel and receiving it in the calorimeter, and of maintaining the jacket of the latter at a con-

* “Calorimetry: Methods of Cooling Correction,” Proc. Amer. Acad., vol. xxiii, p. 245, 1896.

Second, W . This may be determined in two ways.

(a) By calculation from the formula

$$W = \frac{M'c' + M''c''}{c}$$

where M' and M'' are determined by weighing, and c' and c'' either determined by experiment (best) or taken from tables.

(b) By experiment in the usual manner (introducing known quantity of hot water).

Its effect on s and the limiting error will be discussed under effect of M .

Third, M . To find the error in s , due to error in observing the weight, M , we have, by differentiation,

$$\frac{ds}{d(M+W)} = \frac{c(\theta-t)}{w(T-\theta)} = \frac{s}{M+W}$$

Suppose $M+W = 300$ grms. Then in order that the error of s should be within 0.1 per cent, the weight must be taken to 0.3 grms.; with 200 grms. to 0.2 gm. But with the degree of accuracy ordinarily obtainable in reading temperatures to $\frac{1}{10}^{\circ}$ (see below), the weight need not be taken closer than 0.5 gm. for a weight of 200 grms.; so that unless the error in observing temperatures can be reduced there is no necessity for correcting for evaporation, for loss of weight in air, etc., etc. For the same reason it is not necessary to obtain the weight of w closer than 0.5 gm. for a weight of 50 grms.

Fourth, c . Likewise to find $\frac{ds}{dc}$, we have $\frac{ds}{dc} = s/c$; or since $c \approx 1$, it must for an accuracy of 0.1 per cent be correct for the interval employed to 0.001. But the extreme variation of c , for 10° (from 4° to 14° C.), is 0.00033, which makes it apparent that all correction for c is entirely unnecessary, although Kohlrausch makes note of the fact that such a correction should be applied.

Fifth. *Effect of errors in observing temperatures.*

(A) Error in t .

From equation (2) we have

$$\frac{ds}{dt} = \Delta_t s = - \frac{(M+W)c}{w(T-\theta)} = - \frac{s}{\theta-t} \quad (3)$$

From the first of these values we see that in order to diminish the effect of the error in t upon s , we must make $M+W$ as small and $T-\theta$ as large as possible, conditions which conflict with each other; for the larger w , and the smaller $M+W$, is, the smaller will be $T-\theta$. But the condition of things for which $\frac{M+W}{w(T-\theta)}$ will be a minimum, will evidently be $M+W = 0$, a condition which cannot be realized, but which shows

that the minimum quantity of water should always be used, so far as effects of errors in t are concerned. From (3) we get directly the percentage variation of s for a given error in t , when $\theta - t$ is known.

E. g. Suppose $\theta - t = 10^\circ$, then $\Delta_r s = 0.1 \Delta t . s$. Now if we assume the maximum allowable error to be 1 in 1,000, or .1 per cent,

$$\Delta_r s = 0.001 s \dots \text{ and } \Delta t = 0.01$$

or the temperature t must be read to .01 of a degree. If $\theta - t = 5^\circ$, the temperature t must be read to 1.200 of a degree. On the other hand, if $\Delta t = \frac{1}{50}^\circ$ (and we cannot read much closer than this with a thermometer)

$$\Delta_r s = 0.002 . s \text{ for } (\theta - t) = 10^\circ, \text{ an error of } \frac{1}{5} \text{ per cent.}$$

$$\Delta_r s = 0.004 . s \text{ " " " } = 5^\circ \text{ " " " nearly } \frac{1}{2} \text{ per cent.}$$

(B) Error in T.

Errors in T may arise in three ways:

1st. By error in reading T (the *only* error which affects t).

2d. By the fact that the actual temperature of the body may not be that of the atmosphere which surrounds and is heating it, as indicated by the thermometer placed therein. This is avoided by keeping it surrounded for a long time with an atmosphere maintained at a constant temperature (one and one-half to four hours or more, according to the thermal conductivity of the body in question). Theoretically it would require an infinite time for complete equalization of its temperature with that of the surrounding air. The time required for equalization will be very considerably diminished by making the surface of the body as large as possible compared with its volume, or by using thin sheets of the metal or a ball of wire in place of a solid mass. This will be of advantage also in diminishing the time required for the hot body to impart its heat to the water.

3d. By the loss of heat during the time while the body is being transferred from the heating chamber to the calorimeter, which is of course diminished by making the time as short as possible, and by protecting it as well as possible during transfer.

The error of s due to error in T, or $\frac{ds}{dT} = \Delta_T s$, will be

$$\left. \begin{aligned} \frac{ds}{dT} = \Delta_T s &= - \frac{(M+W)c(\theta-t)w}{\{w(T-\theta)\}^2} \\ &= - \frac{c}{w} \frac{(M+W)(\theta-t)}{(T-\theta)^2} \end{aligned} \right\} \quad (4a)$$

$$= \frac{s}{(T-\theta)} \quad (4b)$$

From (4a) we see that to diminish the effect of an error in T we must, as for t , decrease $M+W$, and increase $T-\theta$, as much as possible; but that contrary to the previous case of t , an increase in $\theta-t$ will act injuriously. Likewise by reference to (4b), we see that an increase of $T-\theta$ would really be beneficial, although from (4b) it would seem to be in conflict with the condition that $\theta-t$ should be a minimum.

Since, however, an increase of $T-\theta$ involves an increase in $M+W$, and this, as we have seen in case of t , to be highly undesirable, it is best to decrease the value of $T-\theta$, even at the expense of an increase in the involved error of s , which is much less in this case than in the preceding.

If, as before, we let the maximum error of s be 1 in 1,000, or 0.1 per cent, we have

$$\begin{aligned} \text{When } T-\theta &= 50^\circ, \Delta t = 0.05^\circ \\ \text{" } T-\theta &= 80^\circ, \Delta t = 0.08^\circ \end{aligned}$$

Or if we read T to $\frac{1}{25}^\circ = 0.04^\circ$ the resulting error in s will be less than that involved in reading t to $\frac{1}{100}^\circ$ or $\frac{1}{200}^\circ$.

(C) We have last to consider the effect of an error in determining θ . This is the most important of the errors in the temperature readings, both because of its effect upon s , and the numerous causes which go to produce it, combined with the difficulty of guarding against them.

1st. The error produced in s will be found as before, by differentiating (2).

$$\begin{aligned} \frac{ds}{d\theta} = \Delta\theta s &= \frac{(M+W)c(T-\theta) + (M+W)c(\theta-t)}{w(T-\theta)^2} \\ &= \frac{c}{w} \cdot \frac{(M+W)}{(T-\theta)} + \frac{c}{w} \cdot \frac{(M+W)(\theta-t)}{(T-\theta)^2} \\ &= \frac{s}{\theta-t} + \frac{s}{T-\theta} \end{aligned} \quad \left. \vphantom{\frac{ds}{d\theta}} \right\} \begin{array}{l} (5a) \\ (5b) \end{array}$$

thus involving both corrections already found. Here, since the first correction is generally larger than the second, the most desirable thing to do will be to increase $\theta-t$ (by decreasing $M+W$), rather than to increase $T-\theta$, except by increasing T , which in most forms of heating apparatus has its limit at 100°C .

If as before, we take the maximum allowable error as 0.1 per cent, we have

$$\begin{aligned} \text{For } \theta-t &= 10^\circ \text{ and } T-\theta = 50^\circ, \Delta\theta = 0.0083^\circ \approx \frac{1}{120}^\circ \\ \text{" } \theta-t &= 5^\circ \text{ " } T-\theta = 80^\circ, \Delta\theta = 0.0047^\circ \approx \frac{1}{212}^\circ \end{aligned}$$

Conversely, if we read θ to only $\frac{1}{50}^\circ$ we get

$$\begin{aligned} \Delta\theta s &= 0.0024 = \frac{1}{4} \text{ of one per cent for the 1st case.} \\ \Delta\theta s &= 0.00425 = \frac{2}{5} + \text{ " " " " " 2d case.} \end{aligned}$$

2d. There is another class of errors in θ , not due to errors of reading, but which are even more important than these, viz: errors due to θ never reaching its maximum value required by theory because of the heat received or lost by radiation. Hence θ_n , as observed, will not be the true value suitable for use in (2), but some value lower than this; unless indeed, we start with a temperature so low that the final temperature θ is less than that of the air; in which case θ_n will be too high. To eliminate this error, due to radiation, several methods have been proposed.

(a) Those methods which take account of the temperature of the external air.

The simplest of these is that of Rumford (compensation method). This is to determine by preliminary calculations the rise of temperature in the calorimeter while the body is cooling and make the initial temperature of the water as much lower than that of the surrounding air as the final temperature is higher. The fallacy of this method lies in the fact that the time required for the last part of the operation is much longer than that required for the first. If we make the initial temperature of the water $\frac{2}{3}(\theta - t)$ lower than the external air, we will come nearer to "compensating" for radiation.

(b) Methods of Jamin and Regnault.

Both of these methods depend on a series of observations begun four or five minutes before and continued as long after the introduction of the heated body into the calorimeter. Radiation is proportional to three factors,—time, excess of temperature, and surface. For any given calorimeter, then, the loss per unit of time is a constant $\times (\theta - \beta)$, where β is the temperature of external air or calorimeter jacket. The lowering of temperature due to this loss is, therefore, $A(\theta - \beta)$, during each unit of time for which $\theta - \beta$ is the mean excess of temperature.

Let a series of readings be taken at intervals x_1, x_2, x_3, x_4, x_5 , etc., from the instant of immersion to the time when the reading of the thermometer becomes steady, giving a series of temperatures $\theta_1, \theta_2, \theta_3, \theta_4$, etc. Then during the intervals $x_2 - x_1, x_3 - x_2$, etc., the mean excess of temperature is

$$\frac{\theta_2 + \theta_1}{2} - \beta, \quad \frac{\theta_3 + \theta_2}{2} - \beta, \quad \text{etc.}$$

And the loss of temperature then is

$$\Delta_1\theta = \left(\frac{\theta_2 + \theta_1}{2} - \beta \right) (x_2 - x_1)A$$

for the interval $(x_2 - x_1)$

$$\Delta_2\theta = \left(\frac{\theta_3 + \theta_2}{2} - \beta \right) (x_3 - x_2)A$$

for the interval $(x_3 - x_2)$, etc., etc.

Then if we take the algebraic sum of these variations we obtain $\Sigma\Delta\theta$ as the total correction for the observed temperature θ_n at the end of the experiment, which added to this observed temperature gives the correct value of θ to use in formula (2). This method requires us to know both the temperature of the external air and the quantity A . The first is known from observation; the second can be determined from the formula for loss of heat by radiation, which is given on p. 91, vol. i (Jamin's Physique), as

$$Q = \text{loss of heat per sec} = \frac{1}{4000} kS(\theta - \beta)$$

$$\text{hence } \Delta\theta = \text{ " temp. " } = \frac{1}{4000} \frac{kS(\theta - \beta)}{(M + W)c}$$

where

S is the surface of the calorimeter.
 k is the value of a (small) calorie.

Hence

$$A = .00025 \frac{S}{M + W}^* \quad (6)$$

c being taken as unity.

Method of Regnault.†—To render the observation of the external temperature (a temperature always hard to determine with accuracy) unnecessary, the readings are taken at intervals as before, but commenced before and extended after the time during which equalization is taking place. The whole operation comprises three periods, the first a short period just before the introduction of the body; the second beginning with the introduction of the body into the calorimeter and ending with the maximum temperature; the third, during which a few additional observations are made on the rate of cooling. Let x be the interval between successive readings, a , n , and b the number of readings in the three periods respectively, and $\theta_0, \theta_1, \theta_2 \dots$ to θ_n , the readings of the thermometer during the second period, the body being introduced at the beginning of the $a+1$ th interval, ($\theta = \theta_0$). Also let t_1, t_3 equal the mean temperatures during the first and third periods, and Δ_1, Δ_3 the mean loss of temperature for these periods for the time, x , and let $\theta_{m'} = \frac{\theta_0 + \theta_1}{2}$, $\theta_{m''} = \frac{\theta_1 + \theta_2}{2}$, etc., and $\Delta_2', \Delta_2'',$ etc., be the mean temperatures and corresponding losses of temperature due to radiation during the successive intervals of the middle period.

* The value of the constant term in this formula will of course depend on the nature of the radiating surface of the calorimeter.

† This method of correction is essentially that described in Professor Holman's paper, in which a somewhat different method of reduction is adopted.

Then the maximum observed temperature θ_n at the end of the second period will be less than the true maximum by an amount $\Delta\theta = \sum_1^n \Delta_2$. To determine this quantity we make use of the same principle as before, viz: that the loss of temperature is proportional to the difference of temperature between the calorimeter and external air, or

$$\left. \begin{aligned} \Delta &= \kappa(t - \beta) \\ &= \kappa t - C \end{aligned} \right\} \quad (7)$$

the equation of straight line cutting the Δ axis at a point, $-C$, from the origin.

1.

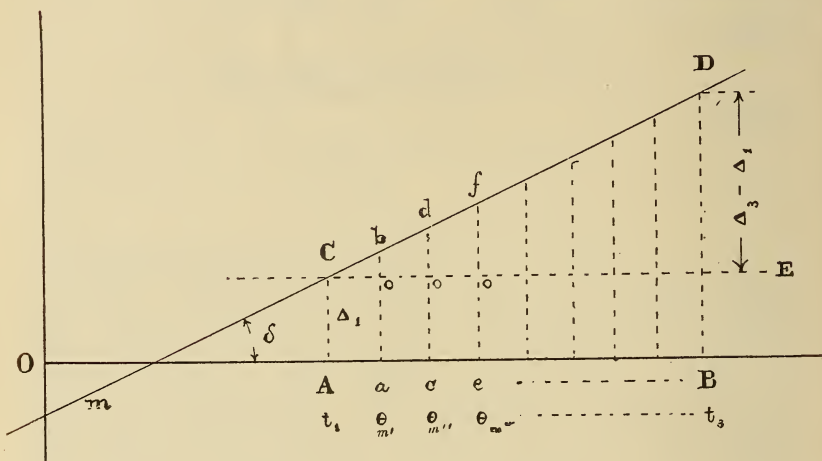

The observations just given furnish data for drawing the line of which (7) is the equation. Thus in fig. 1 lay off $OA = t_1$, the mean temperature for the first interval, and AC , proportional to Δ_1 , the mean loss per interval, x , for same period; likewise lay off $OB = t_3$, the mean temperature for the third interval, and BD , proportional to Δ_3 , the corresponding mean loss. Draw through D, C , the straight line DCM ; this will be the line required. Then it is evident that for any other temperature, as some temperature θ_m during the second interval, the loss, Δ_2 , will be the ordinate to this line at a point whose abscissa is θ_m . The total loss during the whole of the interval $= \sum \Delta_2$. This summation may be effected by a formula derived from inspection of fig. 1. For

$$\begin{aligned} \sum_1^n \Delta_2 &= \Delta_2' + \Delta_2'' + \dots + \Delta_2^n \\ &= ab + cd + fe + \dots + \text{ordinate at } \theta_m \end{aligned}$$

Draw CE parallel to axis of t . Then
 $ab=ao+ob$; $cd=co+od$, etc., etc.

$$\begin{aligned} \therefore \sum_1^n \Delta_2 &= n(ao) + bo + do + \dots + no \\ &= n\Delta_1 + \text{tang } \delta \{ \theta_{m_1} - t_1 + \theta_{m_2} - t_2 + \dots + \theta_{m_n} - t_1 \} \\ &= n\Delta_1 + \text{tang } \delta \left\{ \frac{\theta_0 + \theta_1}{2} - t_1 + \frac{\theta_1 + \theta_2}{2} - t_1 + \dots + \frac{\theta_{n-1} + \theta_n}{2} - t_1 \right\} \\ &= n\Delta_1 + \text{tang } \delta \left\{ \sum_1^{n-1} \theta + \frac{\theta_0 + \theta_n}{2} - nt_1 \right\} \end{aligned}$$

Then to find tang δ we have

$$\text{tang } \delta = \frac{\Delta_2 - \Delta_1}{t_2 - t_1} \quad (\text{from fig. 1})$$

or as a final result

$$\sum_1^n \Delta_2 = n\Delta_1 + \frac{\Delta_2 - \Delta_1}{t_2 - t_1} \left\{ \sum_1^{n-1} \theta + \frac{\theta_0 + \theta_n}{2} - nt_1 \right\} \quad (8)$$

and true temperature after equalization will be

$$\theta = \theta_n + \sum_1^n \Delta_2$$

Other precautions which are of advantage will be readily noted by observing that loss by radiation depends upon three factors: 1st, excess of temperature of calorimeter above the temperature of the surrounding air. This excess will be diminished by making the mass of water M large, so that the rise in temperature, $\theta - t$, will be small. This cannot be carried too far, however, because when the interval becomes small the difficulty of reading temperature to the required degree of accuracy is greatly increased (see 5A and 5C). 2d, surface exposed. Theoretically the best form of calorimeter vessel would be a sphere; but as that is difficult of construction the next best form is that of a cylinder of maximum capacity per superficial area, viz: one in which the altitude equals the diameter of the base. 3d, time. The time element will be reduced by keeping the water well agitated and by using the body in the form of flat strips or wires rolled up into a ball instead of a solid mass.

Finally, there is an error in the observed temperature due to the thermometer itself, which, when its stem is exposed to a temperature below that of the bulb, indicates a lower reading than it should. This error can only be determined in any given case by careful experimental observations of the "time lag" and "stem lag" of the thermometer. To make it as small as possible, the thermometer should be of the smallest possible size, and immersed so deeply in the calorimeter that only enough of the stem projects to make the readings possible.

A better arrangement for observing both the temperature T and the temperature θ would be thermo-elements placed respectively in the heating chamber and in the calorimeter.*

(c) *New Method.*—Returning now to the method of Rumford, it is evident that we might indeed find such a value for the external temperature that the maximum reading θ_n would be the same as though there were no radiation. Thus in the figure below (fig. 1a), if we let the ordinates represent temperature and the abscissas time, we have, when no radiation takes place, the curve BC, whose equation is of the general form $x=f(\log \theta)$. Hence the maximum θ is *never* reached. When we consider radiation, however, we find that the curve BA will, when β has a certain value between t and θ (β being as before the temperature of the air), reach a true maximum at A, which is equal to the theoretical maximum θ . At this point the heat imparted to the water from the body just equals the heat lost by radiation.

1a.

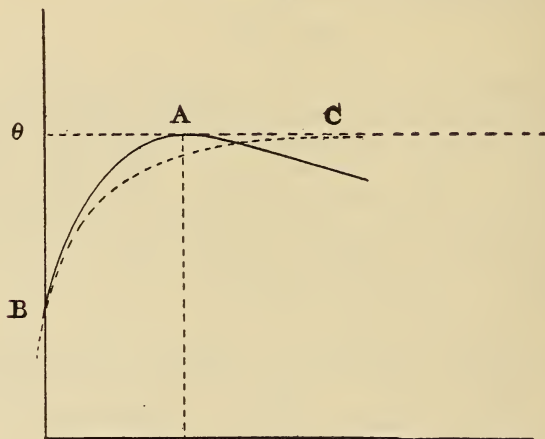

$$\text{The heat lost by radiation, } dq_r = AS(\theta - \beta)dx \quad (9)$$

$$\text{The heat gained from the body, } dq_g = \frac{1}{\sigma} S_1(T_0 - \theta)dx \quad (10)$$

where σ is the coefficient of external thermal resistance; S

* A still more promising method of observing temperatures is the use of the platinum thermometer recently brought to such a degree of perfection by the work of Callendar. Either this, or the thermo-element (now immensely improved by the work of Barus and others), ought on account of its small mass, rapid response to change of temperature, and sensitiveness, to be far better adapted to accurate calorimetric work than the mercurial thermometer now so commonly employed. About the only advantage of the latter is its simplicity and cheapness,—qualifications which determine its use in ordinary laboratory work, but have far less importance in accurate research work.

and S_1 the surfaces of the calorimeter and the body respectively, and T_0 , the temperature of the cooling body. In general σ is itself a function of $T - \theta$ (see Rankine's Treatise on the Steam Engine, p. 260). Thus for a plate of thickness y and thermal resistance ρ immersed in a liquid the flow of heat through the plate is $\frac{1}{2\rho} \cdot \frac{T_x - T_x'}{y} \cdot S_1 dx$; T_x and T_x' being the temperatures of the two sides of the plate. The flow of heat from the liquid of temperature θ_x into the plate on one side is $\frac{1}{2\sigma} (T_x - \theta_x) S_1 dx$, and from the plate into the liquid on the other is $\frac{1}{2\sigma} (T_x' - \theta_x) S_1 dx$. If the temperature is uniform throughout the plate, i. e. if $T_x - T_x'$ is zero, as will be practically true if the thermal resistance ρ is very small compared to the external resistance σ , we get for the total flow of heat from the plate into the liquid at the time, x ,

$$dq_x = \frac{1}{\sigma} S_1 (T_x - \theta_x) dx = -wsdT \quad (11)$$

But from Peclet's formula

$$\sigma + \sigma_1 = \frac{1}{K\{1 + B(T_x - \theta_x)\}}$$

here

$$\sigma = \sigma_1$$

hence

$$\frac{1}{\sigma} = 2K\{1 + B(T_x - \theta_x)\}$$

Substituting in (11) we get

$$dq_x = (T_x - \theta_x) 2K\{1 + B(T_x - \theta_x)\} S_1 dx = -wsdT \quad (12)$$

and at maximum (9)=(10)=(12), or

$$AS(\theta - \beta) = 2KS_1(T_0 - \theta) + 2KBS_1(T_0 - \theta)^2 \quad (13)$$

Hence if we determine T_0 , all the quantities being known except β , this last may be readily calculated.

The determination of T_0 is attended with some difficulties, which may be avoided by expressing T_0 as a function of the time x_0 required for the contents of the calorimeter to acquire the maximum temperature θ .

The total heat imparted to the water of the calorimeter consists of two parts:

1st. Heat taken from body

$$= (T - T_0)ws, \quad \text{at time } x_0 \quad (14)$$

2d. Heat taken from air

$$= AS \int_0^{x_0} (\theta_x - \beta) dx \quad (15)$$

and since the heat contained in the water is the same at maximum point θ (by assumption) as though all the heat from the body had been communicated to it and no radiation had taken place, we have at the time, x_0 , of maximum

$$(T_0 - \theta)ws = AS \int_0^{x_0} (\theta_x - \beta) dx \quad (16)$$

or in general at any time, x , from the instant of immersion

$$(T - T_x)ws = (\theta_x - t)(M + W)c + AS \int_0^x (\theta_x - \beta) dx \quad (17)$$

To find an approximate value of $T_x - \theta_x$ for substitution in (12) we may neglect the last term as small compared with the others, and write

$$(T - T_x)ws = (\theta_x - t)(M + W)c$$

whence

$$(T_x - \theta_x) = T_x \left(1 + \frac{ws}{(M + W)c} \right) - \left(T \frac{ws}{(M + W)c} + t \right) = bT_x - a \quad (18)$$

Then substituting in (12), we get

$$-ws \frac{dT}{dx} = 2KS_1(bT_x - a) + 2KBS_1(bT_x - a)^2$$

Integrating we get

$$x \Big|_0^{x_0} = - \frac{ws}{2bKS_1} \left[\log \frac{bT_x - a}{2KS_1 + 2KBS_1(bT_x - a)} \right]_T^{T_0}$$

or

$$x_0 = \frac{ws}{2bKS_1} \log \left\{ \frac{bT - a}{bT_0 - a} \cdot \frac{1 + B(bT_0 - a)}{1 + B(bT - a)} \right\} \quad (19)$$

or

$$e^{\frac{2bKS_1}{ws} x_0} = \frac{bT - a}{bT_0 - a} \cdot \frac{1 + B(bT_0 - a)}{1 + B(bT - a)} \quad (20)$$

Then solving for T_0 we find

$$\begin{aligned} T_0 &= \frac{a}{b} + \frac{bT - a}{b \{ e^{\frac{2bKS_1}{ws} x_0} [1 + B(bT - a)] - B(T - t) \}} \\ &= \theta + \frac{T - t}{b \{ e^{\frac{2bKS_1}{ws} x_0} + B(e^{\frac{2bKS_1}{ws} x_0} - 1) \}} \quad (21) \end{aligned}$$

* It may be observed that the value of the integral in the second member of this equation is not necessarily zero. In other words the conditions (value of β , etc.), which give the proper value of θ for use in equation (2) are not such as to make the total loss of heat by radiation zero, as assumed by Rumford.

where

$$R = \frac{2bKS_1}{ws} x_0$$

In this equation all the quantities are known, at least approximately, or may be observed or calculated except K , B , and T_0 . The values of the constants K and B for metal plates in contact with water are, according to Peclet (Rankine, p. 260),

$$\begin{aligned} K &= \cdot00119 \\ B &= \cdot1044 \end{aligned}$$

I have not been able to find the data upon which these values are based. They will of course vary with the condition and nature of the cooling surface and will be larger when the water is well stirred than when it is not. The best way is to determine them, for the given body and given calorimeter, by a series of preliminary observations on x_0 , the time required for θ_x to attain its maximum value, θ . In making these observations, t should be made about $\frac{2}{3}(\theta - t)$ lower than β , the temperature of the surrounding air. Three such preliminary observations (made in the same way as they would ordinarily be made to determine s) would suffice (though a larger number reduced by the method of Least Squares would be better) to determine K , B , and T_0 , this last quantity as determined from (21) being practically the same (for such rapid cooling as always takes place in a properly conducted calorimetric experiment) as that which would be determined from the theoretically correct but far more complicated expression (17). Having thus found T_0 , we may then find a first approximation to the value of β from (13); A , the radiation factor of the calorimeter being taken as given by Jamin, or better determined for each calorimeter by experiment.

With this value of β a second set of observations are taken for x_0 and with this new value a second and closer value of β determined as before. Two such successive approximations will suffice to determine β with the desired accuracy.

The use of this method renders any precautions for preventing radiation useless. All that is necessary is to keep the temperature of the surrounding air uniform, and at the determined temperature (practically this is best done by adjusting the initial temperature t of the calorimeter contents), and keep the water in the calorimeter well agitated during the progress of the experiment, while screening the calorimeter from direct radiation from the observer's body. Then the maximum temperature attained will be the theoretical maximum, θ , desired, and radiation, instead of being a disadvantage, will become an advantage inasmuch as it lessens the time of the experiment

and makes the maximum more sharply defined. The greatest drawback to the use of this method is the preliminary labor of observing for and computing T_0 and β . But this preliminary labor is well worth while, when the highest degree of accuracy is aimed at.

Conclusion.—It appears then from the preceding discussion that the greatest possible care should be taken in reading temperatures, and since the errors of these readings are much greater than any others likely to be committed, it is advisable, in order to minimize the effect of these errors, to use

1. A small amount of water in the calorimeter; i. e., a small calorimeter.

2. A large mass of metal having a maximum surface for given weight (sheets or wire);

3. As high an initial temperature, T , as can be conveniently attained.

4. The calorimeter should be surrounded by a water jacket maintained at a constant temperature β , higher than the initial temperature t of the water in the calorimeter by the amount determined by (21) and (13).

Physical Laboratory, Ohio State University,
December, 1888.

NOTES ON CALORIMETRY.

The ordinary method of transferring the hot body from the heating chamber to the calorimeter by allowing it to slide down and out of an inclined tube into the mouth of the calorimeter is open to a number of objections, chief among which is the loss of heat in passing through the air, the loss of water by splashing, etc., and more important than all else, the loss of time in moving the calorimeter up to and away from the heating chamber, and in uncovering and covering the calorimeter at the most critical stage of the operation, when the attention of the observer should be entirely directed to the reading of temperatures, and disturbing influences should be reduced to a minimum. To avoid these difficulties I devised some time ago the arrangement shown in fig. 2. The tube, which forms the heating chamber of a Regnault apparatus, is removed and replaced in a more nearly horizontal position, A, B, fig. 2. A track consisting of two parallel steel wires, tied together at intervals, is laid along the bottom of this tube and continues for some distance beyond the lower end. On this track rolls a square (or cylindrical) double-walled car of sheet copper, mounted on four wheels, two (on one side) with grooved faces, and two (on the other side) with straight faces. In this car is placed, just over a trap door at the forward end, the object whose specific heat is to be determined. When the latter is being heated the car containing it is drawn up into the

heating tube by a silk cord passing over a pulley, and held taut by a mass attached to the free end, whose weight is somewhat less than the component weight along the track, of car and body together, and somewhat greater than that of car alone. The

2.

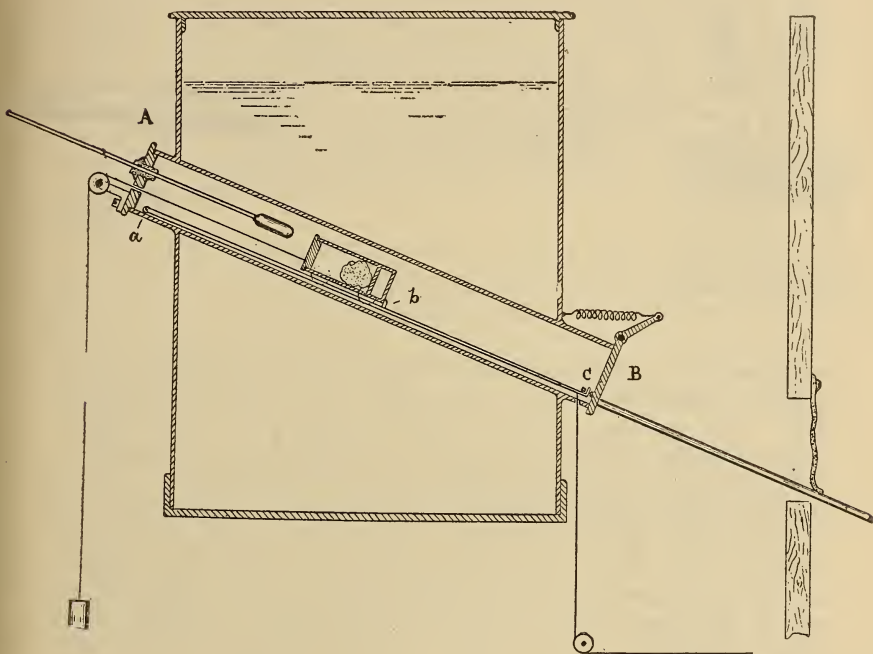

car is held in position by a pin *b*, on the steel wire *abc*, which is pivoted at *a* between the rails of the track. A second pin *c* at the lower end of this wire enters a catch on the inside of the door *B* at the lower end of the heating tube and holds it closed against the tension of a coiled spring.

The calorimeter itself is placed under the lower end of the track (six or eight feet distant from the heating chamber) and consists as shown in section in fig. 3 (taken at right angles to the section of the heating chamber fig. 2), of an inner copper chamber which differs from that ordinarily used in being much shorter (diameter=height) and in having a tightly fitting bottle-shaped top, the opening in which is just large enough to admit the heated body. Just under this opening is a wire basket with attached copper paddles, which is hung on three light brass wires, passing freely through tubular holes at the sides of the neck of the opening and on up through the outer double cover of the calorimeter. They are attached above by

hooks to a light brass ring, which in turn is pivoted in the forked end of a long wooden lever *a, b, c*. This lever is hung on a link at *b* and has a pin at *c* which moves in a slot cut in a plate of brass or hard wood of such shape that *a* moves up

3.

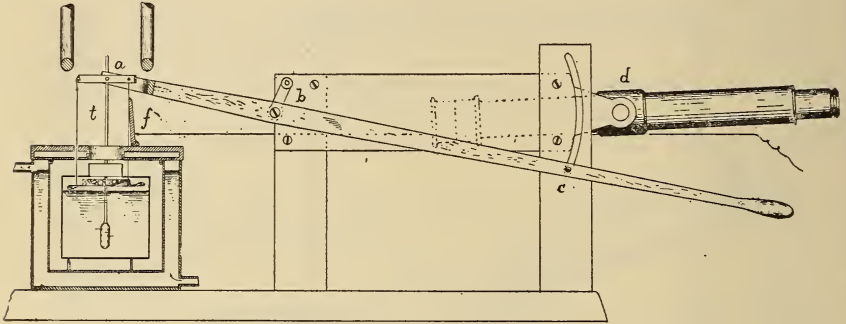

and down in a straight line. The end *c* is so weighted as to slightly overbalance the ring, bracket, etc., hung on the other end. The thermometer, *t*, is read by means of a very short focus telescope, made by slipping over the end of an ordinary reading telescope, a cap carrying a second object glass of about the same focal length as that of the telescope. It is balanced on pivots, *d*, so as to easily follow the movement of the mercury column. The inner calorimeter, which is filled with water almost up to the neck, is completely enclosed in a water jacket whose inner walls are blackened (not left bright as usual). The cover is double, of heavy sheet metal, and the hole in the center through which the body drops into the inner calorimeter has a hinged trap door, *f*, which can be turned back against a step on the calorimeter cover. When a good water supply is available, I have found that the temperature of this water jacket is most easily kept constant by allowing a slow constant stream to flow through it from bottom to top, from a large tank supplied from the city (or building) mains.

The method of introducing the hot body into the calorimeter is almost self-explanatory from what has preceded. The observer at the eye end of the telescope pulls open by aid of a string the trap door in the top of the water jacket, and then by means of a second string pulls down the end of the wire, *ac* (fig. 2), releasing the car and the door, *B*, at the same instant. The car runs rapidly down the track, throwing aside in its course the flaps of woolen cloth which cover the openings in the interposed wooden screens (see fig. 2), and is brought to rest by a rubber buffer which stops it in such a

position that the trap door in the bottom of the car is just over that in the water jacket. A pin fixed in proper position on the track knocks away the catch on the trap door of the car just as the latter comes to rest, and the body falls into the basket (which is held at its highest point by the overweight on the end c of the lever), precipitating the latter, both by its momentum and weight, downward into the water in the calorimeter. As the lever goes down the observer lets go the string which holds the trap door f open, and it also closes. The car, relieved of the weight of w , is pulled back out of the way by the attached weight. The observer himself has then only to observe temperatures while keeping the water in constant and complete agitation by moving the end c of the lever up and down.

The calorimeter is readily removed when temperature observations have been completed, by unhooking the wires, sliding the water jacket to one side from under the track, and lifting off the cover of the latter. The thermometer and wire basket remain in the calorimeter vessel, and are weighed with it, thus avoiding any loss of water, etc., consequent upon their removal.

This apparatus, although it may seem at first sight complicated, is in reality very simple, and readily put together by any one having a small shop in his laboratory, in one or two days. The great advantage resulting from its use will be readily appreciated. It enables, in the first place, one observer to do all the work of observation, although it is convenient to have some one to write down the thermometer readings. The use of the wire basket to catch the hot body, rather than allowing it to fall directly into the calorimeter, has three advantages: (1) it prevents splashing the water, and therefore allows the calorimeter to be filled nearly full, thus obtaining a maximum volume with a minimum of radiating surface; (2) it allows of a more thorough agitation of the water, the body itself being moved through it, and hence a more rapid equalization of temperature in the calorimeter; (3) it prevents any danger of breaking the thermometer bulb or injuring the sides or bottom of the calorimeter when a heavy body is dropped into it.

The use of the car to transfer the body from the heating chamber to the calorimeter not only prevents a loss of heat during the transfer, but also enables a number of small fragments, or even a mass of powder of the substance, to be used without the necessity of using an enclosing bulb, a device which always renders the equalization process slower and more uncertain.

Notes on the Bunsen Ice Calorimeter.

Filling.—More or less elaborate directions are generally given for filling the body of the calorimeter with water and mercury. The following process, which I have used for some time, is very simple, direct and efficient. The required quantity of mercury is first poured into the calorimeter through a small glass funnel, whose stem has been drawn out into a long, fine bulb, which will reach to the bottom of the side tube *b*, of the calorimeter. The calorimeter is then

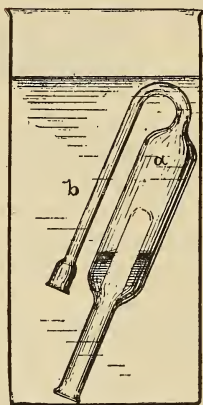

inverted in a beaker of distilled water deep enough to cover it to above the bend of the side tube, as in fig. 4. The mercury already introduced, which is now in the upper part of the water chamber, will hold the calorimeter down under the water. The beaker containing the water is now heated to boiling and cooled. When the calorimeter chamber *a* has been partly filled with water by the cooling, the whole is raised to boiling again, and kept at that temperature until all the air in *a* has been replaced by steam. On cooling again *a* will be completely filled with hot, air free, water. When cool enough to handle, the finger is placed over the mouth of *b* and the calorimeter removed from the water and turned into the upright position. The mercury will run down to the bottom of *a*, leaving, however, some water still in *b*. This is then displaced by more mercury introduced through a funnel as before.

Maintaining at Zero Temperature.—In using the ice calorimeter it is necessary, as has been pointed out by Bunsen, to have the calorimeter surrounded by *pure* melting ice or snow of exactly zero temperature. Since perfectly pure ice or snow is difficult to obtain, it occurred to the writer some time ago that the most convenient way of securing the desired result would be to immerse the calorimeter in a vessel (a wide-mouthed bottle has proved very convenient in practice) filled with distilled water, and freeze a shell of pure ice on the inside of this bottle by placing it in a freezing mixture, leaving a space between ice and calorimeter filled with pure distilled water. When this has been done the whole arrangement is then placed in a larger vessel filled with ordinary crushed ice or snow. If this is not exactly at zero temperature (owing to impurities) the only result will be to cause a slow progressive freezing or thawing in the ice shell of the inner vessel. The distilled water being in contact with pure ice will, if occasionally stirred, remain at zero temperature.

ART. XXXI.—*The systematic position of Crangopsis vermiformis* (Meek), from the Subcarboniferous rocks of Kentucky; by ARNOLD E. ORTMANN, Ph.D.

IN 1872 and 1875 F. B. Meek described* a peculiar Crustacean from the lowermost Subcarboniferous rocks (base of Waverly series) near Danville, Ky., under the name of *Archæocaris vermiformis*, but owing to the imperfect condition of his specimens he did not express any opinion as to the systematic position of this fossil. The Museum of Geology of Princeton University possesses quite a number of specimens of this form, which were collected by M. Fischer at or near the same locality (Boyle Co., Ky.), and which are also for the most part poorly preserved. Yet a few specimens are better, and one of them shows clearly a peculiar feature which enables us to make out its approximate systematic position.

Previously, Crustacean remains closely resembling Meek's species have been reported by Salter† from the Subcarboniferous (Mountain Limestone) of Scotland under the name *Palæocrangon socialis*, the generic name being subsequently changed into *Crangopsis* Salter,‡ in order to prevent confusion with *Palæocrangon* Schauroth. Salter places his fossils among the Macrurous Decapods, considering the presence of a carapace, of seven distinct abdominal segments, and of caudal swimmerts as conclusive. These three characters are all that is known of *Crangopsis*, and *Archæocaris* of Meek shows exactly the same; there is nothing that should induce us to separate generically the American from the Scotch fossil. Accordingly, we should consider *Archæocaris* as a synonym of *Crangopsis*, and the American species should be called *Crangopsis vermiformis* (Meek). The three characters which induced Salter to place his genus among the Decapods are not sufficient to warrant the correctness of this position. On the contrary, these three characters are present, among the Malacostraca, in the same combination also in the living orders of the *Stomatopoda*, *Euphausiacea*, and *Mysidacea*,§ and we cannot make out the proper position of these fossils according to our present knowledge. From one specimen however in the Princeton collection (Mus. No. 1597^c) we learn another very important character.

* Proc. Acad. Philad., 1872, p. 335; Geol. Surv. Ohio, Palæont., ii, 1875, p. 321, pl. 18, fig. 1.

† Trans. Roy. Soc. Edinburgh, xxii, p. 394; Quart. Journ. Geol. Soc. London, xvii, 1861, p. 533, fig. 8.

‡ See Zittel, Handb. Palæont., ii, 1885, p. 682.

§ Compare Boas, in Morpholog. Jahrb., viii, 1883.

Of this specimen the body is complete, showing the carapace and the whole abdomen preserved *in situ*. Fortunately, the hinder and upper part of the carapace is broken away, thus enabling us to see that in addition to the seven abdominal segments exposed in specimens with unbroken carapace, there are, in front of them, *four* other segments present, originally covered by the hinder expansion of the carapace, and these four (thoracic) segments are dorsally perfectly closed, smooth, and uninjured, thus proving that they were not connected and ankylosed with the carapace, but free dorsally. These free thoracic segments are exhibited in a few other specimens (Mus. No. 1597^d), but since in the latter the abdomen is not complete, their exact number cannot be determined.

This character clearly shows that *Crangopsis vermiformis* cannot be a *Decapod*. In the Decapods all the thoracic segments are firmly united dorsally with the carapace. Neither can *Crangopsis* belong to the *Euphausiacea*, because in this order only the last (fifth) thoracic segment is dorsally free, while all the others are united with the carapace. In the *Stomatopoda* the five thoracic segments are free, but they are not covered by the carapace; only in the *Mysidacea* we have the same condition as shown by *Crangopsis*. Thus, according to this character, this genus should be placed in the order of *Mysidacea*, and it is the *first fossil form* assigned to this group.

I think, however, it would be a little rash to assume positively that *Crangopsis* belongs to that group of *recent* animals designated as the order *Mysidacea*, since we know nothing of the other characters of this form. It is true, the character mentioned is present, among the living Malacostraca, only in the order of *Mysidacea*, but it is a mere secondary one, the principal characters being drawn from the differentiation of the appendages of the body. In the fossil *Crangopsis* only faint traces of limbs have been discovered, but their number, their shape and differentiation are entirely unknown, and accordingly we are at a loss to recognize the typical characters of any particular order of the Malacostraca; we may even imagine that *Crangopsis* possessed in the conformation of the thorax the characters of *Mysidacea*, while the limbs were developed according to the Decapod-type, a condition which is not altogether impossible. Since *Crangopsis* belongs to the earliest forms of Malacostraca, we are to expect that it belongs to a primitive group, perhaps to that group which forms the original stock from which all the now living Malacostraca originated. But the presence of a carapace covering entirely the thorax indicates that this genus belongs to the *Thoracostraca*, and further, the fact that the four last thoracic segments are dor-

sally free, shows that closer relations exist to the *Mysidacea* than to any other order.

There is no doubt that the Carboniferous and Permian fossils designated by Brocchi* as a new family (*Nectotelsonidæ*) of the order Amphipoda belong to that primitive group of Malacostraca which gave origin to the different now living orders. This family contains the genera *Palæocaris* Meek and Worthen, *Uronectes* Bronn (= *Gampsonyx* Jordan), and *Nectotelson* Brocchi, but its position among the Amphipods, as maintained by Brocchi, is certainly erroneous. The *Nectotelsonidæ* show a number of characters common to all Malacostraca, but no typical characters of any of the orders of this subclass; they represent a mere collective type of different Malacostracous orders.

The general characters of all Malacostraca are the following: Body with a limited number of segments; the number of the anterior segment is somewhat doubtful, but there are certainly eight segments of the "cormus" bearing the cormopods, and seven of the abdomen or pleon, six of which bear pleopods, the last one forming with the telson a caudal fin. A differentiation between the appendages of the cormus and the pleon is present. This primitive type of Malacostraca is divided into two large sections: the *Thoracostraca*, having a carapace developed and stalked eyes, and the *Arthrostraca* having no carapace and sessile eyes.† The first section is farther characterized by the prevailing presence of the caudal fin (which is reduced only in the Decapoda Brachyura); of the second section only a part of the Isopods retains the caudal fin. In the Thoracostraca the legs are either differentiated in the primitive manner into cormopods and pleopods, or the former are again divided (Decapoda) into three maxillipeds and five pereiopods (thoracic legs). In the Arthrostraca, there is never a differentiation of maxillipeds and pereiopods, but often (Amphipoda) the pleopods are divided into swimming (anterior) and jumping (posterior) feet.

The *Nectotelsonidæ* of Brocchi show on the one hand the primitive characters of the Malacostraca; they have a limited number of body-segments, divided according to the appendages into a cormus and a pleon with a caudal fin. On the other hand no carapace is developed and stalked eyes are present.‡ The latter character, and the shape of the antennæ, and the gill-like appendages on the bases of the cormopods separate this group from the Arthrostraca, and Jordan and Meyer were perfectly right in so far as giving *Uronectes* a position inter-

* Bull. Soc. Geol. France, iii, 8, 1880.

† I disregard the *Cumacea*, which are intermediate between both in this respect.

‡ The details of structure given here are best known in *Uronectes* (= *Gampsonyx*). Compare Jordan and Meyer, Palæontographica, iv, 1, 1854, p. 1, ff. pl. 1.

mediate between the Arthrostraca and Thoracostraca: but in pointing to the resemblance to the Amphipods they were wrong, since there are no closer relations present to that order. The other genera referred by Brocchi to the *Nectotelsonidæ* are only incompletely known, but their general appearance strongly favors the opinion that they really belong to the relatives of *Uronectes*. The description of the genus *Nectotelson* of the Permian of Autun, France, is very poor and contradictory. Brocchi gives it seven thoracic segments (p. 6) and four abdominal segments, but his figures show nothing that might warrant this number, and fig. 1 (pl. 1), indeed, shows clearly that the number *four* for the abdominal segments is incorrect. Further, he says (p. 7) that probably the eyes were small and sessile: but the specimens did not show any traces of these organs! He did not discover in his specimens an appendage of the antennæ: these characters and the much smaller size are the only differences of *Nectotelson* and *Uronectes*. The limbs of *Nectotelson* (pl. 1, fig. 2) are badly preserved, but they resemble apparently those of *Uronectes*.*

As regards the genera *Palæocaris* and *Acanthotelson* of Meek and Worthen,† I refer only to the descriptions and restorations given by Packard‡ from which it is apparent that both are closely related to *Uronectes*.

In order to get an approximate idea of the systematic position of Brocchi's *Nectotelsonidæ*, we may rely upon a combination of the characters of these three or four genera, and if we consider these characters as conclusive for this family, we may say that the *Nectotelsonidæ* show the typical characters of the subclassis Malacostraca; but further on they unite characters of the Arthrostraca (the missing carapace) with those of the Thoracostraca (stalked eyes), thus proving to be a primitive group from which the former as well as the latter might be derived.

I may add here that Packard creates the *suborder Syncarida* for these genera,§ which thus consists of Brocchi's *family Nectotelsonidæ*.

* It is astonishing that Brocchi in comparing *Nectotelson* with *Uronectes* did not consult the paper of Jordan and Meyer quoted above, and that he describes a very bad figure that we possess of *Gamponyx* (he gives a copy pl. 1, fig. 7), while *Gamponyx* (*Uronectes*) is known as completely as we might expect to know a Paleozoic Crustacean.

† *Palæocaris typus*, Coal Measures of Illinois (Proc. Acad. Philad., 1865, p. 49, and Geol. Surv. Ill., ii, 1866, p. 405; iii, 1868, p. 552). *Acanthocaris*, three species from the Coal Measures of Illinois (ibid.). A second species of *Palæocaris* has been described by Woodward from the Coal Measures of England (Geol. Magaz., 1881, p. 533).

‡ Mem. Nat. Acad. Sci., Washington, iii, 1886, and Proc. Boston Soc. N. H., xxiv, 1889.

§ Compare Calman, 1896, p. 801, footnote 1.

This fossil group of Crustaceans has become the more interesting, since very recently a peculiar living species has been discovered in fresh-water pools of the mountains of Tasmania, which was first described by G. M. Thomson* under the generic name of *Anaspides*, and of which W. T. Calman† gives a more detailed investigation, especially with reference to its relation to the fossil forms here under discussion. *Anaspides*, indeed, is the most important discovery among the recent higher Crustaceans, and it is no doubt a living form belonging to the group *Syncarida*. Calman has shown conclusively that the characters of *Anaspides* are a combination of the Podophthalmate type (Thoracostraca) with a completely segmented body and the lack of a carapace, i. e. with Edriophthalmate type (Arthrostraca). But, on the other hand, the details of structure in *Anaspides* point to a closer connection with the "Schizopoda" of the Euphausiid-type as well as of the Mysid-type.‡

I think, however, it is best to regard the *Syncarida* of Packard, including the recent genus *Anaspides*, as a group of equal rank with the other chief divisions of the subclass Malacostraca, namely as an *order*, and, indeed, as the most primitive order from which all the others are to be derived: there is no doubt about the genetic relation of the Euphausiacea, Mysidacea, and Decapoda to the Syncarida, but I am convinced that further study will show that also the other orders of Malacostraca, Squillacea, Cumacea, Isopoda, and Amphipoda are to be connected directly or indirectly with this primitive order.

The chief characteristics of the order *Syncarida* (Packard) derived from the morphological features displayed by the recent *Anaspides* would be the following:

Body with a limited number of distinct segments, differentiated into a "cormus" and a "pleon." No carapace developed. Stalked eyes present. Antennæ with a scale. Cormopods on the coxal joints with "branchial lamellæ," and on the basal joints with an "exopodite." Penultimate segment of the pleon with two well developed appendages forming with the telson a caudal fin.

Comparing *Crangopsis* with the *Syncarida* we see at once that it is distinguished by the presence of a carapace, thus coming clearly under the subdivision *Thoracostraca*. As we have seen above, we may assign it to a particular order, *Mysidacea*, but we must bear in mind that the typical characters of this order drawn from the appendages of the body are not

* Trans. Linn. Soc. Zool. (2), vol. vi, 1894.

† Trans. Roy. Soc. Edinburgh. vol. xxxviii, part 4, 1896.

‡ Compare Calman, l. c. p. 795 and 801.

recognizable, and therefore its position among the Mysidacea is not beyond doubt. Indeed, I do not believe that *Crangopsis* really belongs to the order Mysidacea, but that it is related to the Syncarida. At present, however, we are at a loss to ascertain its true position, since the morphology of the appendages of the body is unknown: yet there is much probability that *Crangopsis* may be a transitional form from the true Syncarida to one of the more specialized groups of Thoracostraca, namely the Mysidacea. Whether we shall connect it systematically with the latter group or with the Syncarida, depends on the knowledge of the other details of structure. In the latter case, the synopsis of the Syncarida ought to be changed as to include this form provided with a carapace.

I may be permitted here to direct attention to a few other Malacostracous Crustaceans found in Palæozoic strata, the position of which with *Crangopsis* is likely more correct than with the Decapoda.

The oldest form referred to the Decapoda, *Palæopalæmon newberryi*,* from the Upper Devonian of Ohio, has been placed by J. Hall among the "*Carididæ*;" but certainly it does not belong to the typical forms of this group, as the name might suggest, which are now called *Eucyphidæ*. Zittel† places this genus among the *Penaidæ*. Although there is no character known which contradicts this position, there is, on the other hand, none which seems to warrant it. On the contrary, no characters are present at all which stamp this fossil as a Decapod: it may belong equally well among the Euphausiacea or Mysidacea. Indeed, in the figure of the only known specimen the carapace appears posteriorly elevated over the abdomen as if separated from the trunk, a feature which suggests a condition similar to that of the Mysidacea or Euphausiacea. But, of course, we cannot judge from this character, as it might be due as well to fossilization.

In the Coal Measures of England a peculiar Crustacean has been found, described by Huxley under the name *Pygocephalus cooperi*.‡ Huxley considers this form to come near to the recent *Mysis*, but to possess some relations to the *Stomatopods*, while Zittel places it among the Decapod-group *Penaidæ*. I should like to endorse the opinion of Huxley in so far as the wanting chelæ, the non-differentiation of maxillipeds and pereopods, and the presence of exopodites are strongly against its

* Whitfield, this Journal (3), vol. xix, 1880, p. 41, and Ann. N. Y. Acad. Sci., vol. v, 1891, p. 571, pl. 12, figs. 19-21. Hall, Pal. N. Y., vol. vii, 1888, p. 203, pl. 30, figs. 20-23.

† Handbuch d. Palæont., ii, 1885, p. 683.

‡ Quart. Journ. Geol. Soc., London, xiii, 1857, p. 363, pl. 13 and 18, 1862, p. 420.

affinity with the Decapods. *Pygocephalus* may belong to the "Schizopods"* in the old sense, which comprise the Euphausiacea and Mysidacea of recent systems, but we are at a loss to say to which of the two latter orders it may be referred.

In conclusion I may add that no Palæozoic Crustacean is known in which Decapod-characters have been observed.† The only genus *Anthrapalæmon*‡ of the Coal Measures of Scotland and Illinois, which has been referred to the Decapods from the appearance of the external form of the body, has incompletely preserved legs, so that its true position remains doubtful. It may be well to remember that true Decapods, i. e. Crustaceans in which typical Decapod-characters are evident, are not found until the Triassic period, and that it may be possible that they did not exist at all in Palæozoic times. On the other hand, it is sure that upwards from the Upper Devonian period, through the Subcarboniferous, Carboniferous and Permian, Malacostraca have been found, which represent either a mere collective type of this subclass or show even some tendency to become more specialized: at least a differentiation of Thoracostraca and Arthrostraca took place probably in the earliest Subcarboniferous or Upper Devonian period. Remains of this primitive group, which may be conveniently called *Syn-carida* (Packard), have not yet been found in Mesozoic or Tertiary strata, *but this group is still represented by the genus Anaspides, living in fresh water on the mountains of Tasmania.*

Princeton University, January, 1897.

* Huxley unites the Schizopods with the Decapods, and, accordingly, he calls *Pygocephalus* a Decapod: but he expressly states its nearer relation to "Mysis," a Schizopod.

† Even an alleged abdomen of a Brachyurous Decapod, *Brachypyge carbonis*, has been described from the Coal Measures of Belgium (Woodward, Geol. Magaz., 1878, p. 433, pl. 11, and de Koninck, Bull. Acad. Roy. Belg. (2), lxxv, 1878, p. 83, figs. 1, 2). It is extremely unintelligible why this fossil should belong to a Crustacean at all, and whoever has seen the abdomen of a living crab, cannot doubt that this fossil is no such thing. Probably *Brachypyge* belongs to the Arachnoidea (compare the Carboniferous *Anthracomarti*).

‡ Salter, Quart. Journ. Geol. Soc., London, xvii, 1861, p. 529, figs. 1-7. Meek and Worthen, Geol. Surv. Ill., ii, 1866, p. 407, pl. 32, fig. 4, and iii, 1868, p. 554. Etheridge, Quart. Journ. Geol. Soc., London, xxxv, 1879, p. 404, pl. 23.

AM. JOUR. SCI.—FOURTH SERIES, VOL. IV, NO. 22.—OCT., 1897.

ART. XXXII.—*On a New Species of the Palinurid-Genus Linuparus found in the Upper Cretaceous of Dakota*; by ARNOLD E. ORTMANN, Ph.D.

THE Geological Museum of Princeton University has lately acquired two unique specimens of a hitherto unknown fossil species belonging to the family Palinuridæ, which are not only the first remains of this group of Decapoda found on the American continent, but which—as regards the completeness of preservation—surpass anything that is known of this group from the European deposits. It is true, Palinuroid-Decapods have been found in Europe, especially in England and Germany, in great numbers, and the systematic relations of these forms—as belonging to the family of Palinuridæ—are beyond any doubt. But there is hardly a form the affinities of which to the living genera of this family have been ascertained: accordingly, for most of them new genera have been created, and although the old generic name of *Palinurus* has been used for some of these European forms, there is nothing that indicates a closer connection of this fossil *Palinurus* with the living *Palinurus* “sensu strictiore.”

The American fossil here to be described not only shows all the chief characteristics of the family, but it is so well preserved that the writer has been enabled to make out its generic position, and he was exceedingly surprised that this fossil from the Upper Cretaceous is congeneric with a species living nowadays in the Japanese seas, namely with *Palinurus trigonus* of de Haan,* the name of which stands at present as *Linuparus trigonus* (d. H.). The genus *Linuparus* created by Gray in 1848 for this Japanese form is—as far as we know—a monotypic genus, containing only that Japanese species just mentioned.

In order to make clear the systematic position of the new fossil, it will be well to give a brief sketch of the generic divisions of the family Palinuridæ, as accepted in modern zoology.†

The family Palinuridæ contains seven recent genera: *Palinurellus*, *Jasus*, *Palinurus*, *Palinustus*, *Linuparus*, *Panulirus* and *Puerulus*. Indeed, some of these genera have not been admitted by some modern carcinologists, but I should say that the differences of these genera are so striking, that one would amply be justified in arranging them into three or

* See de Haan, Fauna Japonica. Crust., decas 5, 1841, p. 157, pl. 39, 40.

† Compare Ortmann, in Zoolog. Jahrb. Syst., vol. vi, 1891, pp. 13–38. I should mention here, that some of the generic names used by me in this revision do not comply with the rules of nomenclature accepted generally. Thus *Avus* should be *Linuparus*, *Senex* should be *Panulirus*, and *Puer* ought to be changed, since it has been preoccupied. (I should like to propose *Puerulus* for it.)

four different families. Only *Palinurus* and *Palinustus* on the one hand, and on the other *Panulirus* and *Puerulus* are more closely related to each other: the other genera differ so widely that they indicate as many lines of development within this family, which are separated since very old geological times. It may be possible to trace back the separation of these lines of development into the earlier Jurassic or even into the Triassic period.

There are three chief groups, namely: 1, that of *Palinurellus* and *Jasus*; 2, that of *Palinurus*, *Palinustus* and *Linuparus*; 3, that of *Panulirus* and *Puerulus*.

According to the morphological characters the first may be called the more primitive, the second the typical, the third the more advanced group. But perhaps it would be well to place *Palinurellus* and *Jasus* in separate groups, since both—although agreeing in some characters not found in the other genera—are so widely different, that no closer genetic relation seems to be present.

The most striking character of *Palinuridæ* is the connection of the frontal parts of the carapace with the so-called segment of the antennulæ as well as with the epistoma, and, on the other hand, the fusion of the basal points of the stalk of the antennæ with the epistoma. The frontal part of the carapace is always united with the segment of the antennulæ outside of the eyes, on either side, but in the two genera first named there is a median connection besides: the rostrum is bent downward and covers completely or partially the bases of the eyes, thus reaching and joining the segment of the antennulæ. These two genera—*Palinurellus* and *Jasus*—are further characterized by the lack of a stridulating apparatus, formed by the first free joints of the antennæ rubbing against the segment of the antennulæ, which seems to be present in all the other genera.

The second and third groups are more closely related to each other, but they are distinguished by one important character: in the second the epistoma is divided longitudinally by a deep furrow, which no doubt indicates the former separation of the basal joints of the antennæ fused into the epistoma. This furrow is wholly wanting in the third group, the epistoma being smooth and even medially. The disappearance of this indication of the primitive separation of the basal joints of the antennæ stamps the third group as a more advanced one than the second. Besides, there is another difference: in the second group the flagella of the antennulæ are always short, while in the third group they are very much longer.

Examining our fossil form, we see at once that it belongs to the second group. The larger specimen shows plainly the connection of the carapace with the epistoma and with the segment of the antennulæ, outside of the bases of the eyes, while

no median connection is present. The epistoma shows the median longitudinal groove characteristic of the second group. The flagella of the antennulæ, however, are not preserved.

There are three genera in the second group. The first is the type genus of the family, *Palinurus* (containing two living species); the others are *Palinustus* and *Linuparus* (containing only one species each). *Palinustus* was proposed by A. Milne-Edwards* for a deep-sea form from the West Indies. The description of it is very poor and even incorrect in some respects, and no figure of it has been published. I am, however, enabled—through the kindness of Professor Alexander Agassiz, who lent me the type specimen for examination—to state, that *Palinustus* comes very near to *Palinurus*, and differs only in the weaker “frontal horns,” which are placed on the outer edge of two very peculiar plates projecting horizontally from the frontal margin and truncated squarely at the apex. In *Palinurus* these projecting frontal plates are wanting and the “frontal horns” are formed by two large, compressed, nearly falciform spines placed close to the frontal margin on either side of the rostrum. In all other respects *Palinurus* differs only slightly from *Palinustus*. The differences of both genera from *Linuparus* are the following. In *Palinurus* and *Palinustus* the carapace, especially the part behind the cervical groove, is evenly arched from side to side, i. e. of sub-cylindrical shape, and it is covered by a multitude of spines and spiny tubercles, becoming scaly in the hinder part. The frontal horns are compressed and separated by a wide space. In *Linuparus* the hinder part of the carapace is distinctly carinate, three keels being present, a median one and two lateral ones. The surface is covered with granules, and a few small spines placed chiefly on the anterior part, thus differing strikingly from the spiny appearance of the carapace of the first two genera, and, further, the frontal horns of the living *Linuparus* lie close together and are depressed (not compressed), forming two broadly triangular plates projecting from the middle of the frontal margin.

Our fossil form comes very near to *Linuparus* in the shape and armature of the carapace. There are three distinct longitudinal keels on the hinder part of the carapace, and only a few short spines distributed in a similar manner as in the living Japanese form. But there is a difference in the frontal horns. The latter are compressed, as in *Palinurus*, but nearer to the median line. The horns are smaller than in *Palinurus* and a little inclined, diverging from the bases outward, and thus they are exactly intermediate in shape and position between the living *Palinurus* and the living *Linuparus*: the distinct lateral compression comes near to that of the former genus, but the inclining direction looks like an incipient depression, and in

* Bull. Mus. Compar. Zool., vol. viii, 1880, p. 66.

their closer position to the median line, the horns approach also the condition seen in *Linuparus*.*

There is no doubt that we are to place the fossil form in the genus *Linuparus*, and although the frontal horns form in some degree a connection with *Palinurus*, there are a couple of other characters of minor importance exhibited by our fossil which occur only in the Japanese *Linuparus trigonus*, as will be pointed out in the following detailed description of the new fossil, which I propose to name

Linuparus atavus, spec. nov.

The two specimens of the Princeton Museum, both males, were collected by Mr. H. F. Wells in the Niobrara group (Upper Cretaceous) at the head of Cotton-Wood Creek, Mead Co., South Dakota. They were broken into numerous pieces, but have been put together again very skilfully by Mr. Gidley. The matrix being extremely hard, it was deemed dangerous to try to work out some parts of the body more completely; thus some parts in either specimen are still imbedded in the matrix: but luckily the specimens supplement each other in an admirable manner, so as to leave only a few details of minor importance unknown. See figures 1-4, p. 297.

MEASUREMENTS.

Of larger specimen (a).

| | |
|--|------------------|
| From anterior frontal margin to hinder lateral corner of carapace | 79 ^{mm} |
| Length of 4 posterior abdominal segments + telson (hinder part of the latter imbedded in the matrix) | 77 |
| Length of the three free basal joints of the antennæ (outer margin) | 39 |
| Breadth of frontal margin | 38 |
| Distance between the frontal horns, | 8 |
| Breadth of carapace, posterior end | 36 |

Of smaller specimen (b).

| | |
|---|------------------|
| Length of carapace | 60 ^{mm} |
| Length of 4 anterior abdominal segments | 31 |

Allowing, in the larger specimen, for the first two abdominal segments one and a half of the length of the third segment (14^{mm}), the approximate total length of the body would be 177^{mm}.

* This intermediate shape of the frontal horns settles the question, whether the triangular frontal processes of *Linuparus* are a bilobed rostrum (as de Haan believes) or the homologues of the frontal horns found in other genera of *Palinuridæ*. They are frontal horns.

Specimen (*a*) shows beautifully the frontal margin, the segment of the antennulæ, the stalks of the antennæ and parts of the flagella, the basal joints of the antennulæ, the epistoma, and the hinder part of the abdomen. The upper surface of the carapace is much crushed, and the place of the sternum is occupied by a large hole. Of the abdomen, the four last abdominal segments and the telson are present; of the first and second segments only a few pieces are recognizable. In specimen (*b*) the upper surface of the carapace is nearly complete, there is only a hole occupying the gastrical region and a few smaller ones; the frontal horns are better than in the first specimen. The anterior part of the abdomen and the sternum are complete in specimen (*b*), but the anterior part of the body (beyond the frontal margin) is imbedded in the matrix, and the posterior part of the abdomen is wholly absent. Parts of the maxillipeds, pereopods, and pleopods are visible in both specimens.

Description. — *Carapace* nearly rectangular in outline. Frontal margin truncate, nearly straight, connected with the segment of the antennulæ on both sides of the eyes. Frontal horns approaching each other, compressed, but diverging from the bases outward, their anterior margin with a few small teeth, no median rostral spine being visible. Antero-lateral angles formed by spines. Cervical groove distinct. Anterior part of carapace (in front of the cervical groove) with two spines just behind the frontal horns, which are a little more distant from each other than the latter, and with three tubercles forming a triangle. A curved, longitudinal series of three spines between the median line and the lateral margins. Hinder part of carapace tricarinate, each keel bearing a number of small spines. Otherwise the surface of the carapace is only granulate and punctate. (The arrangement of the spines on the anterior part is very like to that of the living *Linuparus*!)

Abdominal segments in the median line provided with short, conical spines. (Similar spines are found in *Linuparus trigonus* on the anterior segments, but are wholly wanting in all other genera of *Palinuridæ*, except in one species of *Puerulus*: here, however, they are of a different character!) The first segment has only one spine, the second has two simple spines, on the third segment the posterior one is provided, in specimen (*a*) with one, in specimen (*b*) with two additional tubercles, one behind the other. The fourth segment has two double-spined tubercles; the tips of the spines are placed one behind the other. The fifth segment has two simple spiniform tubercles. On the sixth segment, however, are two low double spines, placed side by side each near the median line, and on the posterior margin are two small spines placed close to the median line. The segments from the second to the fifth have each two sharp tubercles on each lateral part; the sixth has only one. The epimera are spined on the margins, but the

exact number of the spines cannot be determined. Each abdominal segment has a transverse furrow passing across the back between the anterior and the posterior median spines; these furrows are very distinct on the second, third and fourth segments, while they are obsolete on the first, fifth and sixth. Of the telson only a small part of the anterior portion is exposed; the posterior end, which was probably—as usual in this family—soft, is imbedded in the hard matrix.

The segment of the antennulæ is very like that of *Palinurus* or *Linuparus*. It is narrow, elongate-triangular; the lateral borders form a blunt, elevated ridge. The epistoma has a deep median longitudinal furrow, which is bordered anteriorly by a strongly elevated, oblong tubercle on both sides. The phymacerite (opening of the green gland) is visible only on the left side of specimen (*a*). The sternum, exposed beautifully in specimen (*b*), is elongate-triangular in outline. The lateral borders have three spiniform tubercles near the insertions of the second, third and fourth pereopods, and a similar median tubercle a little in advance of the level of insertion of the fifth pereopods.

Of the antennulæ only parts of the basal joint are preserved. The antennæ show the stout and enlarged form usual in the family. The stems have three free joints, the basal one being greatly enlarged and dilated on the inner margin, thus forming, with the segment of the antennulæ, that peculiar "stridulating apparatus" found in the genera of group 2 and 3 of the family. The two other basal joints of the antennæ are narrower than the basal one, but still large and powerful. All three joints are furnished with a number of smaller and larger spines. Of the flagella only a couple of fragments are preserved, but these show a very peculiar feature only found, among the living genera, in *Linuparus*: there exists dorsally and ventrally a distinct longitudinal furrow, so as to render the cross section oval with a constriction in the middle.

Of the mouth parts, traces of the strong and powerful mandibles are seen in specimen (*a*), of the second maxillipeds in specimen (*b*), and of the third maxillipeds in both. Of the latter the distal joints, carpus, propodus, and dactylus, are broken away. The interior margin of ischium and merus is spiny. No traces of an exopodite have been discovered, but it is probable that it is broken away or still imbedded in the matrix.

Of the pereopods (thoracic legs) the first seems to be the stoutest, the second the longest. In specimen (*b*) all the joints of the latter are preserved on the right side (but partly covered by the matrix). The dactylus reaches as far as the end of the stalks of the antennæ, and it is long and slender. The dactylus of the first pereopods is nowhere visible, but in both specimens the propodus of the left sides, showing plainly that

no chelæ were developed, as required by the diagnosis of the family. The following pairs of pereopods decrease in size and thickness. The fifth pair shows plainly in both specimens the male sexual opening. The distal parts from the merus onward are not present in the fifth pair.

Traces of abdominal appendages (*pleopods*) are discernable in both specimens; the right one of the fourth segment in specimen (*a*) is the best preserved, consisting of an oval plate, which is finely striated. Sexual appendages are wanting.

Thus we see that the position of this fossil form with the genus *Linuparus* is warranted not only by the tricarinate carapace, but also by other characters of minor importance, such as the distribution of spines on the carapace, the armature of the abdomen (which in its general plan is exactly like that of *Linuparus trigonus*, and differs from *Palinurus* as well as from the other genera of the family), and the peculiar shape of the flagella of the antennæ. Only the frontal horns differ from those of the living species, but, as I have shown above, they are intermediate between that species and the condition seen in *Palinurus*, and this difference should be regarded as of only specific value: I do not think the shape of the frontal horns justifies the creation of a new genus, and this would be the only way left, if we do not wish to unite this fossil generically with the living Japanese species.

Altogether, there is no doubt that the fossil described above is the nearest relation of the living *Linuparus trigonus*, none of the other living species coming so near to that Japanese Crustacean. This fact is extremely interesting, since it proves that the genus *Linuparus* only slightly modified existed as far back as the Upper Cretaceous time, and, indeed, one might be induced to regard *Linuparus atavus* as the direct ancestor of the living species.

In conclusion, this new fossil gives a hint as to the origin of the geographical range of the genus *Linuparus*. *Linuparus* is not—as might be supposed from its present exclusive distribution in the Japanese seas—a form indigenous to that part of the world: the Japanese seas are not the “center of origin” of this genus, but the living species is to be regarded as the only “relict” left from a former wider distribution. Probably this genus (like most of the other Mesozoic marine animals) possessed formerly a more or less cosmopolitan distribution, but it has been restricted gradually, and the only remnant left at the present time is the Japanese *Linuparus trigonus*, which is to be regarded, accordingly, as a very ancient type among the living Decapods.

Princeton University, February, 1897.

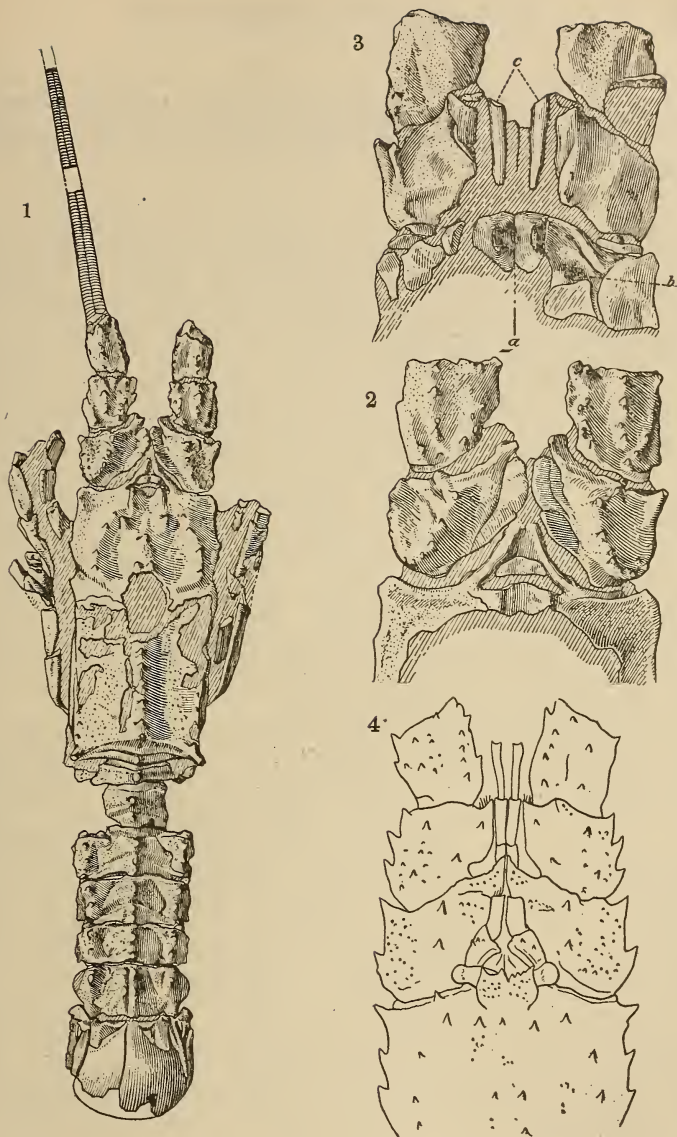

EXPLANATION OF FIGURES.

Linuparus atavus.

- FIGURE 1.—Upper view of larger specimen. $\frac{1}{2}$ nat. size. (Some details of structure of the carapace are supplemented from the smaller specimen.)
 FIGURE 2.—Frontal parts of carapace and base of antennæ, viewed from above, and showing stridulating apparatus. Nat. size (large specimen).
 FIGURE 3.—do., viewed from below. Nat. size —a. Longitudinal groove, dividing the epistoma; b. Phymacerite; c. Basal joints of antennulæ.
 FIGURE 4.—*Linuparus trigonus* (dH.), living Japanese form, the same parts as in fig. 3, copied from the "Fauna Japonica" for comparison. $\frac{1}{2}$ nat. size.

ART. XXXIII.—*Studies in the Cyperaceæ*; by THEO. HOLM.
VI. *Dichromena leucocephala* Vahl, and *D. latifolia*
Baldw.

THE genus *Dichromena* was established by Michaux (l. c. xiii) upon the plant which he named *D. leucocephala*, on account of the snow-white inflorescence, while the generic name, derived from $\delta\acute{\iota}\varsigma$ and $\chi\rho\acute{\omega}\mu\alpha$, should merely refer to the partly discolored involucre. No other name could be more suitable for this singular species, but our plant has, nevertheless, met with the same fate as so many of the other North American plants, viz: to get its name changed and to become confounded with totally different species. Professor N. L. Britton, for instance, changed its name to *Dichromena cephalotes*, while Professor A. S. Hitchcock (l. c. ii) suggested the name *D. colorata*, since he thought that Linnæus had this plant before him when he described his *Schænus coloratus* (l. c. vii). It is not, however, likely that this last change of name will hold good either, for two reasons: first, that Linnæus would hardly have called our discolored *Dichromena* "colored;" and second, because the Linnean diagnosis does not prove that these two plants are really the same.

In regard to the specific name "coloratus," Linnæus did not use this term for discolored organs, but he used "*variegatus*," for instance (l. c. v) "*Arundo indica variegata*," "*Gramen paniculatum aqu. phalaridis sem. folio variegato*," and "*Agri-folium foliis ex albo variegatis*," which plants exhibit the same discoloration as our *Dichromena*. Furthermore, in his *Philosophia botanica* (l. c. ix) Linnæus employed the terms "albicans" and "palescens" for such organs as are whitish or pale green, viz: "*Abrotanum cauliculis albicantibus*," etc., besides that he named a species of *Schænus* "*niveus*" (l. c. x) in contrast to his *Schænus* "*coloratus*"! These two species are now generally recognized as *Kyllinga triceps* and *K. monocephala*, of which the first one is described by Kunth (l. c. iv) with "*squamis hyalino-albidis*" (*niveus*), while the other species, *K. monocephala*, has the same organs "*purpureo-punctulatis*" (*coloratus*).

There are, furthermore, if we examine the diagnosis of *Schænus coloratus*, some points which seem to show that Linnæus did not intend to describe our *Dichromena*; he says, as follows: "*Schænus coloratus, culmo triquetro, capitulo subrotundo, involucreo longissimo plano variegato*." This last character may suit very well for a *Dichromena*, although the involucre of some species of *Kyllinga* is known, also, to show a

similar discoloration. But the very long involucre ("involucro longissimo") does not fit as well for a *Dichromena* as for a *Kyllinga*, and our *K. monocephala* has, as we remember, the involucre leaves very long, much longer than in any species of *Dichromena*. The character "capitulum subrotundum" is, also, without doubt meant for the *Kyllinga*, since Linnæus would surely not have overlooked the several spikes in *Dichromena* with the flowers and bracts almost "biseriate." We really feel assured that if Linnæus had seen our *Dichromena*, he would rather have referred it to *Cyperus*, on account of its biseriate bracts, etc. It is, furthermore, difficult to detect any organ in *Dichromena* which Linnæus observed to be so conspicuous in order to name the species "coloratus." The inflorescence of *Dichromena leucocephala* is, as its name indicates, snow-white, while that of *Kyllinga* is purplish-dotted.

The later editors of Linnæus' works, for instance Murray (l. c. xii), refer *Schænus coloratus* and *S. niveus* respectively to *K. monocephala* and *K. triceps*, and Giseke (l. c. x), in accordance with Rottbøll (l. c. xiv), makes the following statement: "*Kyllinga* Rottbøelli adeo similis est *Schæno*, ut duæ ejus species a Linnæo patre sub illo comprehensæ fuerint, nomine 'colorati et nivei' quæ jam *Kyllinga monocephala* et *triceps* vocantur." Finally, Willdenow (l. c. xi) reached to the same conclusion as Giseke and Rottbøll, and it must be noted that this author, Willdenow, states that he had seen specimens of *Kyllinga monocephala*, a fact that perhaps will be sufficient to decide the identity of the *Schænus* with the *Kyllinga*, instead of with our *Dichromena*.

In considering now our plants, they are of a very singular aspect with their partly discolored involucre and white spikes, but an examination of the details will soon show that our plants are not different in any essential particular from most of the other genera of the *Scirpeæ*. The genus *Dichromena*, for instance, has three characters in common with *Cyperus*, viz: the almost biserially arranged bracts and flowers, the lack of bristles, and finally the development of one of the internodes of the stem into a long scape with the bracts and inflorescences crowded at the apex. But it is at the same time readily distinguished from *Cyperus* by the achene, which in *Dichromena* is crowned with the persistent base of the style.

Let us pass to examine the internal structure of our plants, beginning with the species *leucocephala*. This species shows the general features, which are known to be characteristic of the *Cyperaceæ*, besides that there are a few points in which it seems to differ from all the others which, so far, have been examined. The stem-leaf has a long flat blade, which is perfectly smooth like the other parts of the plant, and green

in contrast to the partly discolored involucreal leaves. The epidermis of the upper face consists of very large cells, which cover the entire surface, excepting near the margins, where a relatively large group of stereome is located, above which the epidermis-cells have become very small. The upper face of

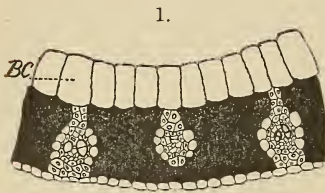

FIG. 1. Transverse section of the leaf of *D. leucocephala*.
B. C. the bulliform-cells. 75 × natural size.

the blade is thus covered with bulliform-cells, in which respect our plant reminds us somewhat of *Cyperus fuscus*, which has been described and figured by Duval-Jouve (l. c. i). The cells of the epidermis of the lower surface are much smaller, and their walls are slightly undulate; we find, also, here the internal cones, which seem to be constantly developed in the epidermis, which covers the stereome. Stomata are to be observed on this, the lower surface; they are not very prominent, and they form longitudinal bands underneath the mesophyll. This last tissue occupies a very large part of the blade and consists of rather closely packed palisade-cells on the lower surface, while it shows a more open tissue on the upper face, just underneath the bulliform-cells. We notice, therefore, that the palisade-tissue and the stomata are exclusively restricted to the lower face of the leaf-blade, a fact which seems due to the extraordinary development of the upper epidermis. The palisade-cells are mostly arranged vertically upon the leaf-surface, but we have, also, observed an approximately radial arrangement around the mestome-bundles. The cells of the mesophyll near the upper surface are polyhedral and leave room for numerous, but small, intercellular spaces. While only a few cells of the lower epidermis contained tannin, the mesophyll was observed to possess quite a number of such reservoirs. Very distinct and well differentiated from the mesophyll is the colorless parenchyma-sheath, which borders on the mestome-bundles and partly surrounds these. We have seen from previous studies that this parenchyma-sheath is generally interrupted by the stereome in the large mestome-bundles, while it forms a closed ring around the smallest ones, which as a rule are not in contact with the hypodermal groups of stereome. *Dichromena* forms, however, an exception to this rule, since, as we shall see later, the colorless parenchyma-sheath does not surround even the smallest mestome-bundles, but is, also, here interrupted by small stereome-elements, widely separated from the epidermis of both faces of the leaf-blade. Inside the colorless parenchyma-sheath is the usual mestome-sheath, which is here

composed of equally thickened cells, those on the leptome-side being smaller and with narrower lumen than the others. The mestome-bundles seem to represent three different forms in the leaf of *Dichromena*, but not so much in regard to the

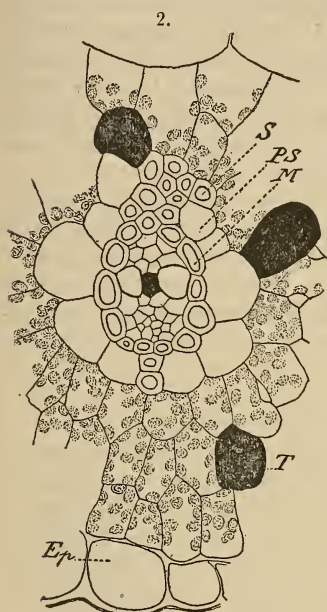

FIG. 2. Transverse section of a mestome-bundle from the leaf-blade. *Ep.*, the lower epidermis; *S*, stereome; *PS*, parenchyma-sheath; *M*, mestome-sheath; *T*, tannin reservoir, indicated with black in four cells of the section. 400 × natural size.

development of the leptome and the hadrome as in regard to the difference in their mechanical support. The largest bundles have the leptome and hadrome well developed and not separated from each other by thick-walled mestome-parenchyma; these bundles are supported by large groups of stereome on both faces, both groups extending from the corresponding epidermis. The mestome-bundles, which may be designated as those of second degree, have, also, a well differentiated leptome and hadrome, besides two groups of stereome, but this tissue does not here extend to the epidermis of the lower face. The smallest bundles contain mostly leptome, and their mechanical support consists only of a few stereome-cells on both faces of the bundle, thus interrupting the parenchyma-sheath, but without coming in contact with the epidermis. The general distribution of the stereome has, thus, already been indicated, and it may be added that no isolated groups of this tissue were observed in the leaf of our plant, not even in the margin, where, although present, the stereome was in connection with a small mestome-bundle. The leaf of *Dichromena* shows, therefore, a rather firm structure in regard to the dense mass of mesophyll, which is entirely destitute of any openings large enough to be designated as lacunes. It has, also, been stated that tannin was observed in the epidermis, and quite abundantly in the mesophyll, besides that it was, also, traced in the hadrome of most of the mestome-bundles.

If we now examine the leaves of the involucre, we find a very singular structure, corresponding to that which Lagerheim (l. c. iv) has observed in *D. ciliata* Vahl from Ecuador. The discolored part, the base of the involucre, has the epidermis of the upper face developed as a stratum of large papillose

cells, while the lower epidermis consists of somewhat smaller cells. The mesophyll is in this part of the involucre composed of rather long, loosely connected cells, all destitute of chlorophyll, giving the leaf the peculiar white aspect in contrast to the upper part, in which the mesophyll is of usual structure and well provided with chlorophyll. The mestome-bundles are small, but represent, nevertheless, the same forms as we have described as characteristic of the proper leaves; cells containing tannin were observed in the mesophyll and in the hadrome. Stomata were observed, but confined to the lower surface of the green part of the involucre.

As to the aerial stem: this is perfectly smooth, terete, slightly furrowed and hollow. It contains a bark rich in chlorophyll and composed of about eight layers of very regularly arranged palisade-cells, which are closely packed, except underneath the stomata, which are well represented in the epidermis. The palisade-tissue does not form closed rings in the

3.

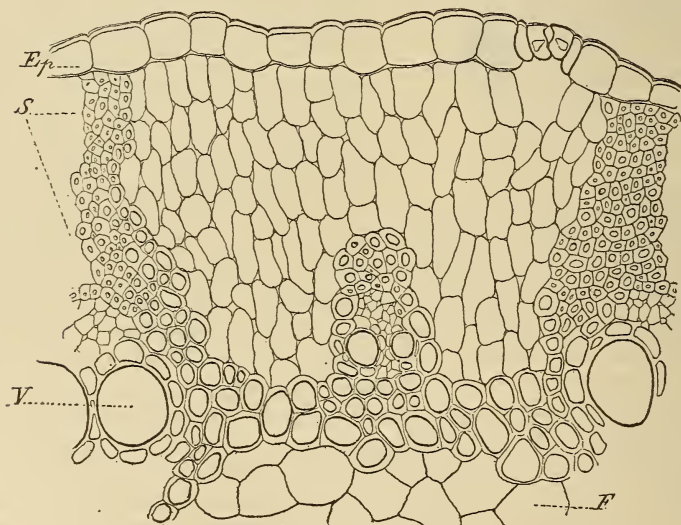

FIG. 3. Transverse section of the stem of *D. leucocephala*. *Ep*, Epidermis; *S*, Stereome; *V*, vessels; *F*, fundamental tissue. 320 × natural size.

stem, but is interrupted by the stereome which support the mestome-bundles. There are three concentric bands of mestome-bundles in the stem, and they are very regularly arranged and represent three degrees of development. Those of the outer- and inner-most band show exactly the same development in regard to the mestome; the leptome and hadrome are very

highly developed, but there is a difference in regard to their mechanical support. Those of the outer band have a large group of stereome all around the bundle, and especially on the leptome side from where the stereome extends outwards to the epidermis. The mestome-bundles of the innermost band are but a few in number and their mechanical support is very insignificant, there being only a few stereomatic cells on the leptome- and the hadrome-side of these bundles. The third form of mestome-bundles are in regular alternation with those of the outer band; they are very small, round and are merely supported by a small group of mechanical tissue on the leptome-side, which group is widely separated from the epidermis by the bark-parenchyma. The leptome and hadrome are, however, well differentiated in these small bundles. (Compare figure 3.)

In considering now the stereome, this forms, as already stated, groups of various strength for the support of the mestome-bundles, and it forms besides an uninterrupted ring inside the two outer bands of mestome-bundles, thus encircling those of the inner band. The innermost part of the stem is occupied by a fundamental tissue, which is composed of large, thin-walled cells, bordering on the rather wide central cavity. Tannin-reservoirs were only observed very scarce in the stem, and they seemed to be confined to the bark, besides that one cell of the hadrome between the two large vessels in all the mestome-bundles was observed to contain this matter.

The rhizome of our species is well developed, creeping and of a comparatively firm structure. It contains a huge bark-parenchyma of roundish cells, which forms a circle all around the central-cylinder. Very conspicuous are the numerous tannin-reservoirs, which abound in the bark, increasing in size towards the epidermis. While no typical endodermis is differentiated, there is, however, a closed ring of stereomatic tissue, just inside the bark, but the cells of this stereome are rather open and with thin walls. It surrounds the entire system of mestome-bundles irregularly scattered in the fundamental tissue, and it is, also, represented as supporting groups on both faces of the mestome-bundles, especially on the innermost face of these. There are two distinct forms of mestome-bundles observable, viz: the ordinary collateral and the so-called concentric, the last of which occur here as perihadromatic; these two forms do not, however, show any special arrangement, but are to be observed scattered among each other. We stated above, that tannin-reservoirs were abundant in the bark; they are again to be observed in the fundamental tissue, where they are quite numerous, besides in the stereome and the

hadrome of nearly all the mestome-bundles. The rhizome shows thus a dense and solid structure with no trace of lacunes or even ducts, the cells of the bark-parenchyma leaving only very narrow intercellular-spaces.

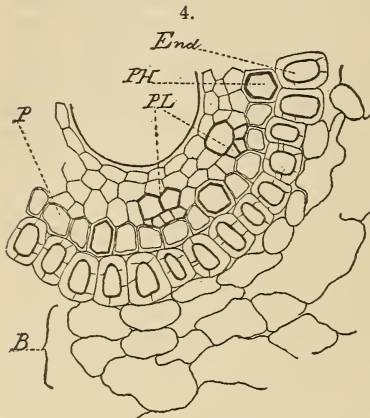

FIG. 4. Transverse section of a root. B, the bark-parenchyma. End, Endodermis; P, Pericambium; PL, Protoleptome; PH, Protohadrome. 400× natural size.

The root shows a very simple structure, which agrees in all respects with that of the *Cyperaceæ* in general. The epidermis becomes thrown off by age, but is then substituted by a thick-walled hypoderm, which surrounds the very open bark-parenchyma, showing numerous lacunes, which have arisen by the tangential collapsing of the bark-cells. The innermost bark is differentiated as a very thick-walled and porous endodermis (*End* in figure 4) which surrounds the pericambium; this last is as usual in the *Cyperaceæ* (with the only exception of *Carex Fraseri*, so far as is known) interrupted by elements of protohadrome, which therefore lie close up towards the endodermis. In alternation with the protohadrome are to be observed small groups of protoleptome, while the center of the root is occupied by a huge vessel, surrounded by a few layers of conjunctive tissue.

This is the general structure of *Dichromena leucocephala*, and if we now institute a comparison of these structures with the corresponding organs of *D. latifolia*, we may be somewhat surprised to find exact uniformity rather than any differences. Both plants have long been unanimously recognized as distinct species, although the differentiation seems to have been based on so slight a character as "the tubercle of the achene being decurrent down the margins." This character did not, however, seem sufficient to Kunth for separating them as two species, and he therefore did not accept the species *latifolia* without a certain reservation and doubt: "*Dichromenæ leucocephalæ* affinis, sed major. Mihi adhuc dubia."

A comparison of their structural characters may simply be expressed in this way, that the mechanical tissue is somewhat more strongly developed in *D. latifolia*, but otherwise no difference was to be detected. That this uniformity in anatomical structure, as observed in the most important organs of the

plants, should be considered sufficient to unite these supposed species is more than probable. There seems always, even in closely related species, to be at least a few distinct anatomical characters to be observed, which in connection with similar morphological ones may prove the species to be valid; but we have, so far, been unable to trace any such divergences as warrant the separation of *Dichromena latifolia* Baldw. from *D. leucocephala* Vahl.

Washington, D. C., February, 1897.

Bibliography.

- I. Duval-Jouve: Etude histotaxique des Cyperus de France. Mém. de l'Acad. d. sc. de Montpellier. Paris, 1874. Plate XXI, figure 12.
- II. Hitchcock, A. S.: Plants of the Bahamas, Jamaica and Grand Cayman. Fourth Ann. Report Missouri Botanical Garden, 1893, p. 141.
- III. Kunth, Carl Sig.: Enumeratio plantarum, vol. 2. Stuttgart, 1837, p. 129 and 133.
- IV. Lagerheim, G.: Note sur une Cypéracée entomophile. Journ. de Bot., May, 1893.
- V. Linné, Carl: Critica botanica Leyden, 1737, p. 178 and 244.
- VI. Linné, Carl: Hortus Cliffortianus, Amsterdam, 1737, p. 495.
- VII. Linné, Carl: Species plantarum, Stockholm, 1753, p. 43.
- VIII. Linné, Carl: Species plantarum, Stockholm, 1762, p. 64.
- IX. Linné, Carl: Philosophia botanica, Wien, 1763, p. 250.
- X. Linné, Carl: Prælectiones in ordines naturales plantarum. P. D. Giseke ed. Hamburg, 1792, p. 132.
- XI. Linné, Carl: Species plantarum. C. L. Willdenow ed. Berlin, 1797, vol. i, p. 256 and 264.
- XII. Linné, Carl: Systema vegetabilium. J. Andr. Murray ed. Göttingen, 1797, p. 103.
- XIII. Michaux, A. Flora Boreali-Americana, 1803, vol. i, p. 37.
- XIV. Rottbæll, Chr. Fr.: Descriptiones et Icones plantarum. Kjøbenhavn, 1786, p. 12.
- XV. Schwendener, S.: Das mechanische Princip im anatomischen Bau der Monocotylen. Leipzig, 1874, p. 82.

ART. XXXIV.—*On an Improved Heliostat invented by Alfred M. Mayer*; by ALFRED GOLDSBOROUGH MAYER.

IN 1885 my father, the late Professor A. M. Mayer, invented a heliostat which is superior in many respects to all forms of this instrument at present existing. As far as I am aware, my father never described his invention, and believing that an

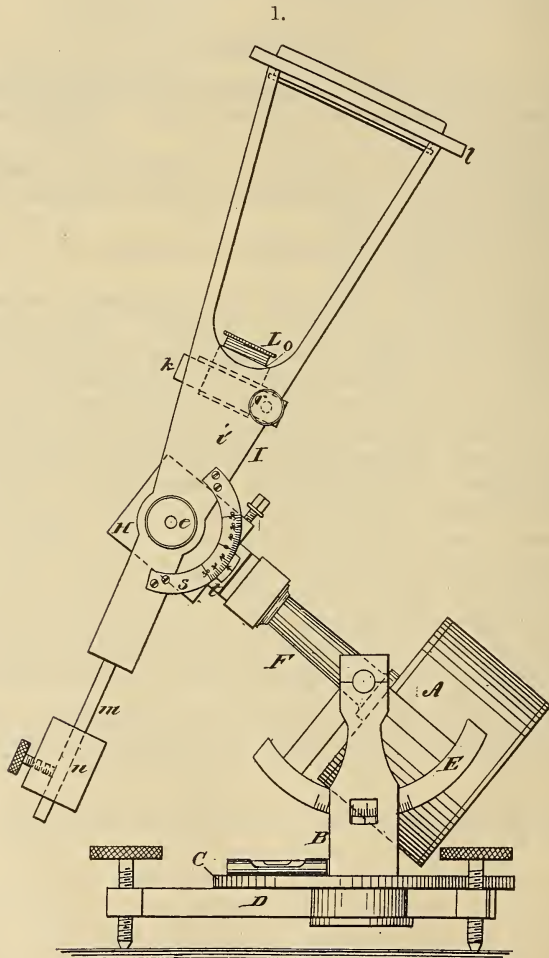

account of its construction may be of service to science, I herewith present a description of the instrument.

The common forms of heliostats consist of one or more plane mirrors carried by a driving clock so as to maintain a solar beam continuously in one direction. The plane mirrors have to be of considerable size, and for accurate work are costly, moreover it is a matter of much difficulty to insure a constant direction of the reflected light owing to the complexity of the mechanism of the driving apparatus.

The heliostat here described avoids these difficulties, is of very simple and cheap construction and possesses the unique advantage that it will maintain a parallel, convergent, or divergent solar beam in one direction with perfect steadiness, and will produce a highly illuminated field of uniform intensity with an amount of heat much less than that given by the forms of heliostats hitherto used.

2.

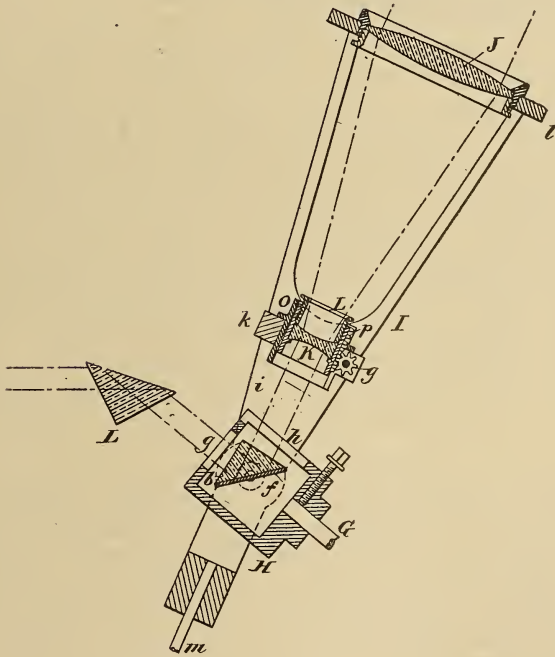

The essential and characteristic parts of the instrument (fig. 2) consist in a biconvex lens (J) which receives the sun's light and produces a convergent beam that is rendered parallel by the small biconcave lens (K). The beam is then reflected in some desired direction by means of the totally reflecting prism (f). The two lenses, J and K, and the prism, f , are all

arranged upon a common axis, and mounted equatorially in a suitable frame-work adjustable to the sun's declination by means of the graduated arc (S, fig. 1). This frame work is controlled by a driving clock (A, fig. 1) of the type commonly used in other heliostats. The beam of light which is reflected from the prism (*f*) may be thrown in any direction by means of the reflecting prism, L (fig. 2), which is placed somewhere near but forms no essential part of the instrument.

This heliostat is especially well adapted to microscopic and spectroscopic work and to projection with the lantern. By its means a very intense beam of sunlight may be obtained, which is so remarkably free from heat that it may be passed with perfect safety through microscopic slides containing the most delicate objects. In this manner beautifully well-defined images of microscopic objects were thrown upon a screen under a magnification of 3800 diameters.

Harvard University, August 1st, 1897.

ART. XXXV.—*Pseudomorphs from Northern New York;*
by C. H. SMYTH, JR.

Pyroxene after Wollastonite.

WHILE studying the mineral deposits of contact origin in the town of Diana, Lewis County, the writer collected several specimens which presented the appearance of pseudomorphs; and such, upon further examination, they have proved to be.

The surfaces of these specimens are rough and rounded, as is so commonly the case with pseudomorphs, while fractures show the crystals to lack homogeneity of structure, the mineral of which they consist having a pronounced cleavage, which has different directions in different parts of the crystal. The specimens are pale greenish-gray, becoming colorless in thin splinters and in sections. While the rough and curved faces and rounded edges make it impossible to determine the original form with absolute accuracy, the approximate measurements afforded, together with the habit of the individuals and of the aggregates, can hardly be explained except as inherited from wollastonite, an abundant mineral of this locality.

Thin sections show each crystal to be made up of a number of individuals of monoclinic pyroxene, in irregularly bounded plates, variously oriented with reference to each other and to the external form derived from wollastonite. The pyroxene shows the usual optical and pyrognostic characters, is colorless, and free from inclusions other than calcite, which occurs as rounded or sinuous patches in and between the plates of pyroxene. This calcite seems to be an infiltration from the surrounding limestone, rather than a product of the alteration of the original wollastonite, though part may be of the latter origin.

In the hope of obtaining further evidence as to the nature of the mineral replaced by pyroxene, a number of specimens of Diana wollastonite have been examined, and, in several of them, grains and strings of pyroxene have been found. While these grains look rather like inclusions, it seems quite certain that in reality they mark the initial stages of the process which finds its completion in the specimens above described. This is even more strongly indicated by thin sections in which the pyroxene may be seen filling cleavage cracks and irregular fissures and cavities in the wollastonite.

The chemical changes involved in the alteration of wollastonite into pyroxene are much simpler than in the case of scapolite and mica, described below. Yet, nevertheless, the former alteration seems to be much less common. This is not surpris-

ing, however, as wollastonite is a metasilicate of simple constitution, while scapolite belongs to the less stable class of orthosilicates and has a very complex molecular structure.

The change of wollastonite into pyroxene is an illustration of the rule, referred to below, that, throughout this region, the addition of magnesia is very common in the formation of pseudomorphs.

Mica after Scapolite and Pyroxene.

Several years ago the writer described* briefly a variety of crystalline limestone, characterized by the presence of abundant crystals of scapolite, which occurs near Gouverneur, N. Y. Since that time the rock has been quarried to some extent for road metal and a supply of material favorable for study has been afforded. The exposure is beside the highway leading from Gouverneur to Hailesboro, and about half a mile south of the former village.

The scapolite is rather uniformly disseminated through the limestone over an irregular area of several acres, projecting above weathered surfaces, and appearing as dark patches on fresh fractures. With it are associated a light-gray pyroxene, brown amphibole, titanite, a little pyrite, and an abundance of rich brown mica. While this association of species is suggestive of contact metamorphism, the irregular diffusion of the minerals over a considerable area, together with the absence of all zonal structure and of any exposure of igneous rocks, necessitates the correlation of the minerals with the general metamorphism of the region, by whatever cause or causes that may have been produced.

None of the minerals show perfect crystal form, but the scapolite and pyroxene, with which the present communication is particularly concerned, are often distinctly prismatic and sometimes bounded by fairly good planes in the prism zone. The crystals range in size from very small up to a maximum length of about three inches. The color of the scapolite is a dull grayish-black and in most cases it appears to be, at least slightly, decomposed and softened. Some specimens are, however, quite tough and lustrous. Close to many of the crystals the enclosing limestone shows a greenish or yellowish zone which looks almost like serpentine.

The interesting feature of the scapolite is the relation it bears to the associated mica. The latter mineral occurs in prismatic forms which, at first glance, might be taken for simple crystals of phlogopite. But, on closer examination, it is seen that each prism is a complex aggregate of mica plates, the per-

* Trans. N. Y. Acad. of Sciences, xii, p. 213.

fect basal cleavage having the greatest variety of orientation in different parts of the crystal. The obvious conclusion, that the mica is pseudomorphous, is entirely substantiated by occasional specimens of unusual perfection showing the crystals composed wholly of mica, but having eight, instead of six, faces in the prism zone, and thus reproducing the form and habit of the scapolite.

The intermediate stages in the production of the pseudomorphs of mica after scapolite are abundantly shown. Indeed, most of the scapolite crystals are partially changed. As a rule, the alteration proceeds from the margin towards the center, but there are many exceptions, and the operation shows much irregularity.

In thin sections, the scapolite shows a strong double refraction and the species is probably near wernerite. Very abundant black inclusions, probably carbonaceous, account for the black color of the mineral. These inclusions often show a perfect zonal arrangement, and there is nearly always a surface layer which is quite free from them. In the growth of the pseudomorphs this regularity of distribution becomes obscured, and there seems to be a tendency for the inclusions to become somewhat segregated. As alteration proceeds, the double refraction becomes very weak, the mineral takes on a rather fibrous structure and the fibers have a positive optical character. In this condition the mineral behaves like serpentine, yields water and has a decidedly serpentinous appearance. Whether this is a step towards the formation of mica, or an entirely independent alteration representing different conditions, is not evident. The latter alternative, however, seems much more probable, and harmonizes better with the facts observed.

The mica, as seen under the microscope, is quite pale in tint with moderate pleochroism, and shows the very low axial angle of biotite, of which it is doubtless the phlogopite variety. As indicated by examination of hand specimens, the mica scales grow into and through the scapolite quite irregularly, with every variety of orientation.

The pyroxene associated with the scapolite has, also, a decided tendency to pass over into mica, and the change is shown in several sections. But, as a rule, the pyroxene has a less regular form than the scapolite, and it is doubtful if any of the more perfect pseudomorphs are to be referred to the former species. It must be admitted, however, that a positive conclusion upon this point can hardly be based upon such crude forms as the pseudomorphs present. The intimate mingling of scapolite and pyroxene in several sections makes it probable that some of the pseudomorphs are of composite origin, in which case the

form might be derived from either one of the minerals involved.

Among the large variety of pseudomorphs after scapolite, mica holds an important place, and many instances of its occurrence have been described, particularly in Europe. Nevertheless, as so often happens in phenomena of this kind, it is by no means easy to account for the details of the process of alteration. The necessary magnesia is readily afforded by the surrounding limestone; indeed, magnesian pseudomorphs, notably talc and serpentine, are abundant throughout the limestone belts of Northern New York. But the sources of the iron, potash and fluorine, together with the precise nature of the chemical reactions involved, remain a matter of great uncertainty.

In connection with this alteration of scapolite, two specimens of the same mineral in the Root collection of Hamilton College are of interest. On one of these, from Edwards, minute crystals of pale yellowish-green epidote partially coat the surface of, and penetrate cracks in, the stout light-gray crystals of scapolite. While this cannot be classed as a clear case of pseudomorphism, it can hardly be questioned that the epidote has grown at the expense of the scapolite, and would have entirely replaced the latter mineral had the process not been checked by changing conditions.

As is the case with mica, epidote is a not uncommon pseudomorph after scapolite, occurring in a number of European localities.*

The second specimen, above referred to, comes from Pierrepont, and consists of more slender crystals of scapolite associated with dark-green pyroxene. Some of the scapolite crystals are coated with a thin layer of garnet, and this mineral penetrates the scapolite in sinuous threads and bands. As in the previous case, the relation between the two minerals can hardly be accidental and is such as to suggest that the garnet has derived a part of its constituents from the scapolite, and might, ultimately, have entirely replaced the latter mineral. The alteration of garnet to scapolite is described by Cathrein,† but the opposite change, above indicated, the writer has not found treated.

It is unfortunate that the very limited supply of material interferes with a more thorough study of both these latter examples of alteration.

Hamilton College, Clinton, N. Y., May, 1897.

* Roth, *Allg. Chem. Geol.*, i, p. 391.

† *Zeitschr. f. Krystall.*, x, p. 433.

ART. XXXVI.—*On the Chemical Composition of Hamlinite and its Occurrence with Bertrandite at Oxford County, Maine*; by S. L. PENFIELD.

IN the summer of 1890, Mr. W. E. Hidden and the author published a short description of a rhombohedral phosphate occurring with the rare minerals herderite and bertrandite at Stoneham, Maine. Only a single specimen, showing a few minute crystals, was ever found at the locality, and the investigation was therefore incomplete, being confined to determinations of the crystallization and physical properties and the identification of phosphorus, aluminium, fluorine and water, while from its association it was supposed that it would also contain beryllium.

The mineral was named *hamlinite* in honor of Augustus C. Hamlin of Bangor, Maine, who has always taken a keen interest in collecting and studying the minerals of his State and especially the beautiful tourmalines from Mt. Mica and vicinity. As stated in the original article, the incomplete description was published for the purpose of calling attention to a mineral which would probably prove to be interesting, and also in hopes that others would be led to look for the mineral and find it. This hope has not been in vain, for Mr. Lazard Cahn of New York had the good fortune to discover among a suite of minerals from Oxford County, Maine, some specimens showing rhombohedral crystals of a mineral, unknown to him, which he gave to the author, suggesting that they might prove to be the rare mineral hamlinite. It is hoped that additional information may be obtained concerning the exact locality at which the mineral is found, so that a supply of specimens may become available for distribution. The mineral was readily identified as hamlinite by its rhombohedral crystallization, basal cleavage, positive double refraction, and blowpipe reactions.

The crystals are implanted upon feldspar and muscovite and are associated, like the ones from Stoneham, with apatite, herderite and rarely bertrandite. The crystals present two prominent habits: One a combination of the rhombohedrons $r, 10\bar{1}1$ and $f, 02\bar{2}1$, developed as shown in the accompanying figure. On these crystals there are occasionally small basal planes and slight horizontal striations on the rhombohedral faces near their juncture with the base. The other habit is essentially a combination of the hexagonal prism of the first order, $10\bar{1}0$, with the base, but, owing to a vicinal

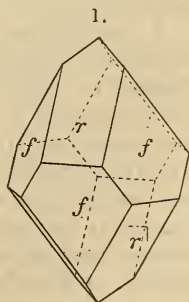

development and rounding, the prismatic faces have a tendency toward a steep rhombohedron, and the basal planes are marked by triangular prominences.

The crystals attain at times a diameter of 3 to 4^{mm}, but are not well adapted for measurement owing to the vicinal character of the faces. The following measurements can claim to be only approximations, since there were usually several reflections of the signal of the goniometer from each face, and it was impossible to tell upon which one the cross-hair of the telescope should be placed. The calculated angles are those derived from measurements of the hamlinite from Stoneham, $c=1.135$, but the crystals from that locality showed a vicinal development of their faces, and the values can not, therefore, be considered as very exact.

| | Measured. | Calculated. |
|--|-------------------------------------|---------------|
| $r \wedge r, 10\bar{1}1 \wedge \bar{1}101 =$ | $88^\circ 41'$ | $87^\circ 2'$ |
| $f \wedge f, 02\bar{2}1 \wedge \bar{2}021 =$ | $109 \ 11$ | $108 \ 2$ |
| $r \wedge f, 10\bar{1}1 \wedge 02\bar{2}1 =$ | $54 \ 44 \text{ and } 54^\circ 47'$ | $54 \ 1$ |

It was found to be practically impossible to select by hand-picking a sufficient quantity of the pure hamlinite crystals for an analysis, and, therefore, a number of specimens upon which the crystals were observed were pulverized, and the hamlinite separated from the other minerals by means of the heavy liquids. Apatite, however, could not be thus separated, but, owing to the fact that hamlinite is almost insoluble in boiling dilute hydrochloric acid, it was possible by treatment with successive portions of acid until the solution gave no test for calcium to remove the apatite completely. All possible precautions were taken to make the separation and purification of the mineral as complete as possible, and the mineral, when examined with the microscope, showed no visible impurity. The specific gravity of the hamlinite varied considerably, that portion which was taken for the chemical analysis being between 3.159 and 3.283, while some of the mineral was still a trifle higher and some a little lower.

A qualitative analysis indicated the presence of aluminium, strontium, barium, phosphorus, fluorine and water, and the absence of calcium and beryllium. In the quantitative analyses the strontium and barium were weighed together as sulphates and subsequently separated as recommended by Fresenius,* by a double precipitation of the barium as chromate. The fluorine was weighed as calcium fluoride, and the latter was tested and found to be pure by conversion into sulphate. Water was determined in two ways; first by fusing with dry sodium carbonate and weighing the water directly,† second by loss on

* Zeitsch. für anal. Chemie, xxix, p. 413, 1890.

† This Journal, xlviii, p. 37, 1894.

ignition, using a weighed quantity of lime to retain the fluorine.* The air-dry powder lost only 0.16 per cent by heating to 100°, and the water was not expelled until the mineral was heated nearly to redness, thus indicating the presence of hydroxyl.

The results of the analysis are as follows:

| | | | | Average. | Ratio. | | |
|-------------------------------------|-------------|-------|-------|----------|-----------|---------|------|
| P ₂ O ₅ ---- | | 28.92 | | 28.92 | .204 | | 1.00 |
| Al ₂ O ₃ ---- | 32.29 32.30 | | | 32.30 | .316 | | 1.55 |
| Fe ₂ O ₃ ---- | | .90 | | .90 | | | |
| SrO ---- | 18.33 18.53 | | | 18.43 | .178 | } .204 | 1.00 |
| BaO ---- | 4.10 3.89 | | | 4.00 | .026 | | |
| H ₂ O ---- | | 11.93 | 12.07 | 12.00 | ÷9= 1.333 | } 1.435 | 7.03 |
| F----- | 1.93 | | | 1.93 | .102 | | |
| SiO ₂ ---- | .96 | | | .96 | | | |
| K ₂ O ---- | .34 | | | .34 | | | |
| Na ₂ O --- | .40 | | | .40 | | | |
| | | | | 100.18 | | | |
| Oxygen equivalent of fluorine, | | | | .81 | | | |
| | | | | 99.37 | | | |

The ratio of P₂O₅ : Al₂O₃ : (Sr+Ba)O : (OH+F) is very nearly 1 : 1.5 : 1 : 7, which gives the formula Al₃Sr(OH)₇P₂O₇, or better [Al(OH)₂]₃[SrOH]P₂O₇, where strontium is partially replaced by barium and hydroxyl by fluorine.

By the method of preparing the mineral for analysis traces of adhering feldspar and mica could not be wholly avoided, and, although the small quantities of Fe₂O₃ and alkalis may belong partly to the hamlinite and partly to impurities, these have been neglected in making the calculations. If the alkalis together with their equivalent of Al₂O₃ (1.06 per cent), the Fe₂O₃ and the SiO₂, in all 3.62 per cent, are deducted from the analysis and the remainder calculated to one hundred per cent, the results are as given below, where they are compared with the theoretical composition, where Sr : Ba = 7 : 1 and OH : F = 13 : 1.

| | Found. | Calculated. |
|--------------------------------------|--------|-------------|
| P ₂ O ₅ ----- | 30.20 | 30.31 |
| Al ₂ O ₃ ----- | 32.67 | 32.65 |
| SrO ----- | 19.25 | 19.29 |
| BaO ----- | 4.18 | 4.08 |
| H ₂ O ----- | 12.53 | 12.48 |
| F ----- | 2.01 | 2.04 |
| <hr/> | | |
| | 100.84 | 100.85 |
| O=F ----- | .84 | .85 |

* This Journal, xxxii, p. 109, 1886.

In its chemical composition hamlinite holds a unique position among minerals, as strontium and barium have never before been observed as essential constituents of a phosphate and this is the first time that a pyrophosphate has been recorded.

Note concerning Bertrandite Crystals from Oxford County, Maine.

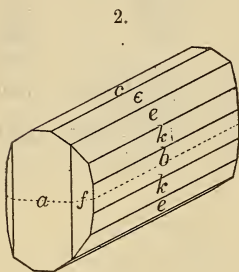

Associated with the hamlinite just described there was one specimen showing prismatic crystals averaging about 2^{mm} in length and 1^{mm} in diameter, which proved to be the rare mineral bertrandite. The habit is shown in the accompanying figure and the forms are as follows :

| | | | |
|-----------|-----------|------------------|--------------|
| a , 100 | c , 001 | ϵ , 011 | k , 0·12·1 |
| b , 010 | f , 130 | e , 031 | |

The crystals are in reality twins, two hemimorphic individuals being united by their basal planes, and occasionally the line of twinning may be traced horizontally across the a , f and b faces. The specific gravity was found to be 2·571. The measured angles are given below, together with the calculated values derived from the axial ratio $a : b : c = 0·56885 : 1 : 0·5973$.

| | Measured. | Calculated. | | Measured. | Calculated. |
|--|------------|-------------|--|-----------|-------------|
| $f \wedge f$, 130 \wedge 130 | = 119° 20' | 119° 16' | $c \wedge \epsilon$, 001 \wedge 031 | = 60° 50' | 60° 50' |
| $c \wedge \epsilon$, 001 \wedge 011 | = 30 50 | 30 51 | $c \wedge k$, 001 \wedge 0·12·1 | = 82 20 | 82 4 |

In closing the author desires to express his thanks to Mr. Cahn for calling his attention to this new occurrence of hamlinite and bertrandite.

Laboratory of Mineralogy and Petrography,
Sheffield Scientific School, May, 1897.

SCIENTIFIC INTELLIGENCE.

I. CHEMISTRY AND PHYSICS.

1. *On the Properties of Highly Purified Substances.*—In consequence of recent experiments showing that many chemical changes take place only in the presence of some substance, presumably water vapor, going to establish the general rule that all chemical changes depend on the presence of this vapor, SHENSTONE has been led to study the apparent exceptions to this rule more carefully. His first experiments were directed to determine the influence of moisture (1) upon the production of ozone from oxygen by means of the electric discharge, and (2) upon the stability of ozone. The apparatus used was quite elaborate, built up entirely of glass, and sealed before the blowpipe. It was filled with oxygen, generated within the apparatus from a mixture of potassium and sodium chlorates mixed with a little solid potash, the ozonizer was set in operation and the resulting ozone carefully dried with phosphoric oxide; this operation being repeated several times. Finally water vapor free from air was admitted to the exhausted tube, and then oxygen, the apparatus being cooled to 0° . The ozonizer was then put into operation and the amount of ozone generated deduced from the resulting contraction. The maximum yield of ozone was 13.6 per cent and the minimum 13.3. Repeating the experiment with the oxygen dried so that the pressure of the aqueous vapor present was assumed to be not over 0.0001^{mm} , the yield never exceeded 11.1 per cent. Moreover, the ozone obtained appeared to be singularly instable. Direct experiment showed that moist oxygen well ozonized, could be maintained at 26.4° for 9 hours with a loss of only 2 per cent, the loss during the last 4 hours being only 0.4 per cent. Dry oxygen, on the other hand, when strongly ozonized and kept at 0° for 33 minutes, lost 1.6 per cent of its ozone. Hence it appears that moderately dry ozone at 0° undergoes decomposition about 30 times as rapidly as the damp gas at 26.4° . On drying the oxygen still more completely (so that the water-vapor pressure had been reduced to $.000,000,001^{\text{mm}}$) only 0.2 per cent of ozone was formed; showing that well-dried oxygen scarcely ozonizes at all. In a second series of experiments, the behavior of carefully dried chlorine, bromine and iodine with well-dried mercury was studied. The chlorine was generated by the electrolysis of fused silver chloride within the apparatus, a large Fleuss pump and two five-fall Sprengels being used to produce the exhaustion. The bromine and iodine used were also purified with great care. The mercury was prepared from mercurous nitrate or mercuric oxide, and repeatedly distilled. All the materials were dried with the greatest care. On introducing the mercury in a glass bulb into a tube and then filling this with the chlorine, bromine or iodine, it was observed that on breaking

the bulb, there was immediate and rapid action in the cold, the chlorine and bromine being absorbed very soon, the iodine more slowly. Hence the author concludes that the action between chlorine, bromine and iodine on the one hand and mercury on the other does not depend on the presence of water vapor. Additional experiments were made to determine the effect of the silent discharge and of direct sunlight upon highly purified chlorine, but with negative results.—*J. Chem. Soc.*, lxxi, 471, May, 1897.

G. F. B.

2. *On the Liquefaction of Fluorine.*—From the properties of the known compounds of fluorine, the conclusion readily follows that fluorine itself can be liquefied only with great difficulty. Advantage was taken therefore of the lecture upon fluorine given by MOISSAN at the Royal Institution in May, to combine the apparatus for its manufacture which he had brought from Paris, with the unequalled facilities possessed by DEWAR at the Institution, for producing low temperatures, in order to attempt its liquefaction, the results of which are given in a joint paper. The fluorine was prepared by the electrolysis of potassium fluoride dissolved in anhydrous hydrofluoric acid. The fluorine gas was freed from the vapors of hydrofluoric acid by means of a bath of alcohol and solid carbon dioxide. The liquefying apparatus consisted of a small cylinder of thin glass having a platinum tube fused into its upper portion, within which was a second tube also of platinum. The gas entered through the annular space between the tubes, passed into the glass envelope and escaped through the inner tube. Liquid oxygen was used as the refrigerant, several liters of it being required. The apparatus being cooled down to the temperature of quietly boiling liquid oxygen (-183°), the current of fluorine gas passed through it without liquefaction and without attacking the glass at this low temperature. On making a vacuum above the oxygen, a rapid ebullition took place and a liquid collected upon the interior of the glass envelope, no gas now escaping from the tube. On closing this tube with the finger, the glass bulb soon became filled with a clear and very mobile yellow liquid, having the same color as the gas in a stratum one meter thick. Hence fluorine liquefies at about -185° . On removing the apparatus from the bath of liquid oxygen, the temperature rose and the liquid fluorine began to boil, evolving abundance of the gas. Experiments were made upon the action of this gas upon substances cooled to very low temperatures. Silicon, boron, carbon, sulphur, phosphorus and reduced iron, cooled in liquid oxygen, did not become incandescent when placed in an atmosphere of fluorine. Nor at this temperature did fluorine displace iodine from iodides. But it still decomposed benzene and turpentine with incandescence at 180° . When a current of fluorine gas is passed through liquid oxygen a white flocculent precipitate is rapidly formed. This thrown on a filter deflagrates violently as the temperature rises.—*C. R.*, cxxiv, 1202, May, 1897; *Chem. News*, lxxv, 277, June, 1897.

G. F. B.

3. *On Normal and Iso-pentane from American Petroleum.*—By means of a dephlegmator devised by them, YOUNG and THOMAS were able in 1895 to isolate normal hexane from petroleum ether in a nearly pure state. By using a very short water condenser at the top of this dephlegmator, and by combining with it a regulated temperature still-head, the authors have now succeeded in separating normal pentane from iso-pentane. The material used was a complex mixture of butanes, pentanes, and hexanes with some benzene and a little hexanaphthene. Three fractionings sufficed to eliminate the butanes, hexanes, benzene and hexanaphthene for the most part. Then the residues, of about 1030 grams, were shaken first with concentrated sulphuric acid, then with a mixture of strong nitric and sulphuric acids; being finally treated with caustic potash and dried with phosphoric oxide. The details of the eleventh fractionation are given in a table in which the lowest fractions are mainly iso-pentane and the highest normal pentane; the intermediate ones being mixtures of these. The fall in temperature of the vapor during its passage through the still-head is greatest for the middle fractions and least for the highest and purest fractions. After 13 fractionings the middle fractions had become very small and the two pentanes were separately fractionated, the normal pentane 8 times and the iso-pentane 11 times. In this way 175 grams of pure normal pentane and 101 grams of iso-pentane were obtained. The former boiled constantly at 36.1° under a pressure of 754.5^{mm} (or 36.3° at 760^{mm}) and the latter at 27.95° at 760^{mm} . The constants of the iso-pentane thus obtained were compared with those of the synthetically prepared substance and showed a close agreement.

The properties of the normal pentane thus obtained are given in a separate paper by YOUNG. The boiling point remained absolutely constant at 36.3° at 760^{mm} . The specific gravity, determined in the Perkins form of Sprengel tube, was $0.64536-0.64541$ at 0° and 0.63313 at 12.91° . The volumes at different temperatures agree closely with those of Thorpe and Jones. The critical temperature was found to be 197.2° and the critical pressure 25100^{mm} ; one gram having a volume of 4.303^{cc} at the critical temperature. From his results the author shows that the densities of liquid and saturated vapor become equal at the critical temperature and hence defines the apparent critical temperature therefore as the temperature at which the densities of liquid and saturated vapor become equal. This temperature was found to be the same whether the temperature had been previously raised or lowered and whether the volume was constant or variable.—*J. Chem. Soc.*, lxxi, 440, 446, April, 1897. G. F. B.

4. *On the Heat of Combustion.*—The formula of Dulong which gives the heat of combustion of solid and liquid fuels as a function of their composition is as follows:

$$\varphi = 81c + 345 \left(h - \frac{o}{8} \right)$$

in which c , h and o represent the percentages of carbon, hydrogen and oxygen respectively. If a general expression $\varphi = Ac + Bh - Co$ be taken, the numerical value of the coefficient, $A = 81$, must be maintained, since it corresponds to pure carbon, and all known data (from 8060 to 8140) prove that the figure 81 must really be taken for each per cent unit of carbon in the fuel (the accuracy of the measurements being within the limits of from 1 to 2 per cent of the total heat of combustion.) For hydrogen, however, the coefficient $B = 345$ cannot be maintained, because it has been obtained from data relating to the burning of gaseous hydrogen, while in ordinary liquid or solid fuel the elasticity of the gas is lost. Its hydrogen must be considered as if liquefied and consequently B must not exceed 300, supposing as usual that the resulting water is in the liquid state. In order to find the true coefficients suitable for practical purposes MENDELÉEFF takes the value of $\varphi = 4190$, which is the correct value for cellulose within one per cent, and is also the average of 79 most complete determinations for fat coals (by Maler, Alexeyeff, Damski, Diakonoff, Miklaschewski, Schwanhöfer and Bunge) and the average for naphtha fuel. From this he finds

$$\varphi = 81c + 300h - 26(o-s)$$

(s being sulphur). This formula represents with an accuracy of from 1 to 2 per cent the heat of combustion of pure charcoal, coke, coals, lignites, wood, cellulose and naphtha fuels. It applies of course to the best determinations only; especially to those which have been made in a calorimetric bomb where the error is less than 1 or 2 per cent. This formula of course is only an approximate empirical expression of facts; but it corresponds at the same time to the numerical value of the coefficient B for hydrogen which theoretical considerations would lead us to expect.—*J. Chem. and Phys. Soc. Russe*, xxix, 144; *Nature*, lvi, 186, June, 1897.

G. F. B.

5. *The capillary constants of molten metals.*—This is the subject of an inaugural dissertation (Göttingen, 1897) by HENRY SIEDENTOPF. The author has employed Quincke's method of obtaining the capillary constants by means of falling drops (1868). Whereas Quincke, however, depended upon the determination of the weight of the drops, the present author has based his results upon the measurement of the curvature of their surface and their size. The metals experimented upon were cadmium, tin, lead, mercury and bismuth. For each the *surface tension* and *specific cohesion* were determined at a temperature near that of fusion. The results are given in the following table:

| | Temperature of fusion. | Surface tension. | Specific cohesion. |
|---------------|---------------------------|---------------------|-----------------------|
| Cadmium | 318° | 84·85 | 21·25 |
| Tin | 226° | 62·43 | 17·87 |
| Lead | 325° | 51·94 | 9·778 |
| Mercury | —39° | 46·29 | 6·767 |
| Bismuth | 264° | 43·78 | 8·755 |

6. *Relations between the Geometric constants of a Crystal and the Molecular Weight of its Substance*; by Professor G. LINCK. (Abstract of a paper published in vol. xxvi of Groth's *Zeitschrift für Krystallographie*.)—The author has already called attention* to the fact that the characteristics of crystals, i. e. their geometric and optical constants, stand in direct relation to the atomic or molecular weight of the elements contained in them. This is most clearly shown in the eutropic series: a eutropic series being defined as a series of substances, crystallizing similarly, but differing, only in that they each contain a different element, though the elements are yet similar according to the periodic system of Mendeléeff. If such a series is arranged according to increasing molecular or atomic weight, then the series, for all characteristics of the crystal, remains unchanged. The fundamental law of these phenomena the author has designated "Eutropy."

For the present investigation it was necessary to know the system to which the crystal belonged, its axial relations, the specific gravity and the atomic weight. Of these, the atomic weights were taken exclusively from Krafft's *Lehrbuch der Chemie*. The specific gravities were taken from one or the other of the three books of Dana (1893), Rammelsberg (1881), or Websky (1868). So far as it was possible to decide, only such values were used as belonged to chemically homogenous material. In like manner the geometric constants, the axial ratios, were for the most part, and wherever possible, taken from a single author (Groth, *Tab. Uebersicht*, 1889).

The method employed is stated by the author as follows: If we assume with Fock, that the smallest conceivable crystal is identical with the molecule,—although this is not an essential condition for the further development of the subject here discussed—then the relative size of the molecule may be computed from the volume. This is not the molecular volume, as defined in terms of molecular weight, M , and specific gravity, d , according to the formula $\frac{M}{d}$, but the volume of the smallest crystal expressed

as a product in terms of its geometric constants. As representing the smallest crystal, instead of the hypothetical actual polyhedron, the author assumes (after Schrauf) an ellipsoid whose volume is proportional to that of the fundamental form. This ellipsoid, designated as the crystal-volume, CV , is therefore regarded as the extreme case of a combination.

The crystal-volume is computed from the crystallographic axes of the fundamental form. These divide the fundamental form into eight irregular tetrahedra of equal volume. Of each one of these we know the length of the three edges corresponding to the axes, and also the three angles α , β , γ , which these axes form

* *Zeitschrift für physikalische Chemie*, xix, 193.

with each other. From the above data we have the volume of the tetrahedron v , from the formula

$$V = \frac{1}{3} abc \sqrt{\sin s \cdot \sin [s - \alpha] \cdot \sin [s - \beta] \cdot \sin [s - \gamma]}.$$

where s represents the half sum of the angles α, β, γ . The volume of the entire, fundamental form would consequently be eight times as large, or in rectangular coördinates, $V = \frac{4}{3} abc$. The contents of the corresponding ellipsoid is, in rectangular coördinates, where the coördinate axes become the axes of the ellipsoid, $= \frac{4}{3} \pi abc$.

For the volumes of the various crystal systems we have, if we denote the quantity under the radical by A , the following formulas:

I. Regular; $CV = \frac{4}{3} \pi$ (where $a = b = c = 1$).

II. Tetragonal and Hexagonal; $CV = \frac{4}{3} \pi c$ (for $a = 1$), $= \frac{4}{3} \pi a^2$ (for $c = 1$).

III. Rhombic; $CV = \frac{4}{3} \pi ac$ (for $b = 1$), $= \frac{4}{3} \pi bc$ ($a = 1$), $= \frac{4}{3} \pi ab$ ($c = 1$).

IV. Monoclinic and Triclinic;

$$CV = \pi \frac{8}{3} ac \sqrt{A} \quad (b = 1), \text{ etc.}$$

For the regular system the ellipsoid is a sphere, for the tetragonal and hexagonal systems an ellipsoid of revolution, and for the others an ellipsoid whose semiaxes are x, y, z .

If the crystal-volume so computed were equal to the actual volume of the smallest crystal, or to that of the molecule, then it would only be necessary to multiply this value by the specific gravity of the substance under consideration in order to obtain its molecular weight in terms of water as the unit. The value of the crystal-volume as computed is, however, only proportional to the actual volume of the molecule, and hence the product, $d \cdot CV$, represents only a value proportional to the molecular or atomic weight, taken with reference to water or hydrogen as the case may be, and this value is to be multiplied or divided by some number in order to give the molecular or atomic weight. Since, however, this number is not known, we are not able to use the computed value $d \cdot CV$. We can use it, however, as soon as we consider the entire eutropic series and apply the law of eutropy to the values thus found.

It is therefore evident, that in the case of eutropic crystals, the crystal-volumes must form a series, such that with increasing atomic or molecular weight they either decrease, or what is more probable, increase. In like manner the products $d \cdot CV$, that is, the crystal-weights, must stand in accurate ratio to each other.

We ask further, are then the computed crystal-volumes of all members of a series mutually equivalent? This also must be answered in the negative, for it must not be forgotten that in each substance the lengths of the coördinate axes are taken with reference to a new unit of length, since in each case we put one axis equal to unity. We ought, however, to refer the crystals of the various members to the same unit of length, and only then

would the computed values, $d \cdot CV$ or CV , be equivalent to each other. If the products, $d \cdot CV$, were originally equivalent, then the quotients $Q = \frac{d \cdot CV}{M}$, where M is the simplest molecular or atomic weight, should be the same for all members of the same series. If we have found the quotient Q_1 for one substance, then from this we can obtain the actual equivalent weight $d \cdot CV_1 = Q_1 \cdot M$, by multiplying it by the atomic or molecular weight, and by dividing this value by the specific gravity of the substance under consideration we obtain the actual equivalent crystal-volume, $CV_1 = \frac{Q_1 \cdot M}{d}$.

The quotient, $\frac{d \cdot CV}{M}$, is obtained by dividing the crystal-volume by the molecular volume, $\frac{M}{d}$. The difference between the equivalent weights, $d \cdot CV$, of a series must, since the weights themselves are proportional to the molecular weights, stand in the same ratio as the difference between the corresponding atomic or molecular weights. This latter proposition includes, however, an extension of all our previous considerations touching isomorphic bodies, possibly even a part of the morphotropic ones.

It only remains to say a few words concerning the relations of heteromorphic modifications of the same substance. It is evident that the molecular weight of heteromorphic modifications stand in some simple rational ratio to each other, and consequently, in connection with the above considerations, it follows that the products, $d \cdot CV$, must also stand in the same simple ratio, or, that equivalent crystal-volumes possess equal weights.

In presenting the results of his calculations, the author gives a series of thirteen tables. Of these, seven are devoted to heteromorphic modifications of the same substance, as, for example, graphite and diamond, marcasite and pyrite, calcite and aragonite, etc. In all of these cases the crystal-volume (CV), the product of this by the specific gravity ($d \cdot CV$) and the molecular volume (MV) are given; finally, the quotient of the crystal-volume divided by the molecular volume ($Q = \frac{CV}{MV}$) is deduced.

These last values agree closely in the case of the substance in each table, only showing such variations as can be explained by the inaccuracy of the data available. For instance, for graphite, $Q = 3.732$; for diamond, $Q = 3.695$. Again, for calcite, $Q = 0.097295$; for aragonite, $Q = 0.09730$.

From these tables, then, it appears that the theory above developed is in accord with the facts; further, that in case of the complete knowledge of one modification of a substance the determination of one of the quantities, CV or d , of another modification is sufficient for the computation of the other. For example, as soon as the axial ratio and specific gravity of graphite are known

the specific gravity for the regular diamond may be computed. In the case of tetragonal and hexagonal crystals also, either the axis c or a , or the specific gravity, may be computed; in the remaining crystal systems, only the specific gravity on the one hand, or the crystal volume on the other may be computed. From the crystal volume one geometric constant may be computed backwards, only in case the others are already known.

Tables VII to XIII give the data and calculated values for a series of isomorphous or eutropic substances, as arsenic, antimony, bismuth; also, beryllium, magnesium, zinc, cadmium; again, aragonite (CaCO_3), strontianite (SrCO_3), witherite (BaCO_3), cerussite (PbCO_3), etc. The discussion of these tables, though highly interesting, would require more space than is available here. It must suffice to quote the conclusions deduced by the author from them, as follows:

(1) The actual volumes of the various chemical compounds, if formed into equivalent crystals, stand in a very simple relation to each other.

(2) The weights of these equivalent volumes stand in the same relations to each other as the molecular weights.

(3) The volumes in a eutropic series increase with increasing molecular or atomic weights.

(4) The weights of equivalent volumes always increase with increasing atomic weights.

(5) Bodies which are isomorphous but not eutropic likewise stand in a very simple relation to each other according to their crystal volume or their actual volume as the case may be.

(6) Many crystals which have heretofore been considered eutropic or isomorphic are not so, since they probably possess a larger or smaller molecular weight according to the number of atoms.

7. *The Induction Coil in practical work, including Röntgen Rays*; by LEWIS WRIGHT. 172 pp. London, 1897 (Macmillan & Co.).—This little volume, by a well known writer, appears opportunely at a time when the induction coil is being called upon for active use more generally than ever before. Many of the workers experimenting with X-rays have not had the advantages of extensive practice in the laboratory, and they especially, as well as others, will be grateful to the author for preparing this excellent summary of the subject.

II. MISCELLANEOUS SCIENTIFIC INTELLIGENCE.

1. *British Association*.—The sixty-seventh annual meeting of the British Association for the Advancement of Science was held at Toronto from August 18 to 25. It was a more than usually notable occasion, rendered so chiefly by the number and character of the scientific men who came from England to attend it, also by the enthusiastic work of the Canadians at home, and further by the coöperation of members of the American Associa-

tion. The opening address was delivered by the President, Sir John Evans, and other valuable addresses and lectures marked the meeting; numerous important papers were read in the different sections. After the close of the meeting various excursions were undertaken, one of them to the Pacific Coast. The Association is to meet at Bristol next year and in Dover in 1899.

2. *Notes on Greenland glaciation.*—Prof. R. S. TARR has contributed numerous interesting details to our knowledge of the glacial phenomena exhibited on the west coast of Greenland.*

In the paper on the Cornell glacier (Bull. Geol. Soc. Am., vol. viii, pp. 251-268, pls. 25-29, March, 1897) he maintains that the angular topography does not necessarily indicate freedom from ice invasion,—that the upper Nugsuak peninsula has all been glaciated—that the glacier has recently withdrawn and is now in process of retreat, with a slight recent advance preceding this retreat.

Professor T. C. Chamberlin, reviewing this paper in *Science* (vol. v, pp. 748-753, May, '97) criticizes some interpretations there made, which the author defends in a later communication (l. c., p. 804).

In the *American Geologist* the author has described the remarkable "Rapidly of weathering and stream erosion in the Arctic latitudes (vol. xix, pp. 131-136). In a later paper, on "Evidence of Glaciation in Labrador and Baffin land" (vol. xix, pp. 191-197, March, 1897), observations on the shores of Labrador and Baffin land lead him to conclude that glaciation has been general over these surfaces, and that the ice has withdrawn from these regions in very recent times.

In another paper, "Valley Glaciers of the upper Nugsuak peninsula, Greenland" (vol. xix, April, 1897, pp. 262-267), description is given of the valley glaciers, and the "dying glaciers," which are interpreted as the last traces of retreating glacial sheets.

H. S. W.

3. *Revision of the Apodidæ.*—CHARLES SCHUCHERT, in a recent article in the *Proceedings of the U. S. Nat. Museum* (No. 1117, vol. xix, pages 671-676). On the fossil *Phyllopod genera, Dipeltis and Protocaris, of the family Apodidæ*, revises the genus *Dipeltis* Packard, describes a new species from the Lower Coal Measures, Morris, Ill., and shows the relation of *Dipeltis* to *Apus*, rather than *Cyclus*. In rearranging the family Apodidæ, a new subfamily *Apodinæ* is proposed, to include the Cambrian genus *Protocaris* and the recent genera *Lepidurus* and *Apus*; and another new subfamily *Diplitinae* is proposed, to include the Marine Upper Carboniferous *Dipeltis* Packard. H. S. W.

4. *New Meteorite from Canada.* (Communicated.)—The Geological Survey of Canada has recently acquired, through the instrumentality of its Director, Dr. G. M. Dawson, a mass of meteoric iron, which it is proposed to designate as the Thurlow meteorite. It was found by Mr. E. S. Leslie, Jr., May 12th, 1888,

* See this Journal, vol. iii, pp. 223-229 and 315-320.

on about the center of the twenty-eighth lot of the sixth concession of the township of Thurlow, Hastings County, in the province of Ontario. This meteoric iron, which would appear to have been brought to the surface by ploughing, is described by Dr. Hoffmann as an irregularly-shaped, truncated pyramidal mass, with a more or less rectangular base, measuring 16 by 13.5, or including an elongated projection, 17 centimeters, in its diameters, and 10 centimeters in height; its weight is 5.42 kilos. The entire surface is pitted, and coated with a chestnut-brown, slightly glimmering, film of oxide of iron.

5. *Observations on Popocatepetl and Ixtaccihuatl*; by OLIVER C. FARRINGTON. Field Columbian Museum. Publication 18, Geol. series, vol. i, No. 2, pp. 71-120, pls. vii-xviii, 1897.—In this brief account of a personal examination of this interesting geological region Dr. Farrington has given a vivid description of the geographic and geologic features of the mountains, perfecting his sketch by reference to particulars recorded by previous observers, and illustrating the paper by numerous reproductions of photographs.

H. S. W.

6. *L. Évolution régressive en Biologie et en Sociologie*, par MM. JEAN DEMOOR, JEAN MASSART et EMILE VANDERNEDELDE, pp. 1-324, figs. 84, Paris, 1897. (Bibliothèque scientifique internationale, Felix Alcan.)—The authors, being specialists in the fields of biology and sociology, have combined forces to discuss the analogies between the phenomena of "règression" in the evolution of organism and regression in society. They conclude that the transformations of organs and of institutions are always accompanied by regression, that regressive evolution is irreversible and, consequently, with a few exceptions, is more or less final (*nettes*), and that regressive evolution is caused by limitation of the means of subsistence—food, capital or the forces of labor, etc. The book is modern and full of suggestive thoughts, both for the biologist and for the student of social problems.

H. S. W.

7. *The Birds of Colorado*; by W. W. COOKE. 141 pp. Fort Collins, Colorado (The State Agricultural College, Agricultural Experiment Station, Bulletin No. 37).—This pamphlet gives a list of the birds of Colorado, so far as identified up to the present time, with notes on their distribution, habits of migration, etc. The State is unusually rich in number of birds, more so than any other in the Union except Nebraska. A complete bibliography of Colorado ornithology is given in pp. 20 to 39. Copies of this publication may be obtained free of charge by addressing the Director of the Experiment Station at Fort Collins.

8. *The Mammoth Cave of Kentucky: an illustrated Manual*; by HORACE C. HOVEY and RICHARD ELLSWORTH CALL. 107 pp. 1897. Louisville, Ky. (John P. Morton & Co.)—Future visitors to the Mammoth Cave will be glad to have in hand this full and well-illustrated guide book to that most interesting locality.

TILLY FOSTER MINERALS.



The famous Tilly Foster Mine has been probably permanently abandoned, the pumps pulled up and 125 feet of water now cover the ore bodies, the miners have departed and not a good specimen is to be had. Under such circumstances our customers will read with unusual interest that we have just purchased the entire collection of the Superintendent of the mine, including the finest **Blue Brucites** ever found, a number of very choice **Chondrodites** and **Clinochlores** and many other most interesting specimens, such as fine **Magnetites** and **Serpentine pseudomorphs**.

THAUMASITE.

We have been buying up all of this most interesting mineral which we could secure and now have so large and fine a lot of specimens that we are able to sell them at about one-sixth our original prices, viz., 10c. to \$2.00. A fine cabinet-size specimen mailed on receipt of 15c. It may be safely asserted that no other mineral has so interesting a composition.

SIPYLITE.

This exceedingly rare mineral, also of most interesting composition, a niobate of erbia, is once again in stock and we now have the best and largest lot ever obtained. Probably no more will ever be found. Specimens ranging in size up to 10 ounces, \$1.50 per ounce.

ANORTHITE CRYSTALS.

100 good crystals and groups just received direct from Japan, 5c. to 50c. each. Also an interesting little collection of Japanese minerals, many of which have not been seen in this country previously.

ICELAND ZEOLITES.

The wonderful display of **Stilbite**, **Heulandite**, **Scolecite**, and **Ptilolite** now in our show-cases has never been approached. Our own collector journeyed all the way to Iceland expressly to secure them. Choice cabinet-size specimens 50c. upward; small specimens 10c. to 35c.

SPLENDID ENGLISH MINERALS.

Our own collector secured over 1200 fine specimens of **English Fluorite**, **Calcite**, **Barite**, **Aragonite**, **Scarlet Quartz**, **Quartz** and **Hematite**, **Kidney Ore**, etc., including many new types and varieties, and the bulk of these we are selling at the lowest prices on record. 10c. to 25c. are favorite prices for specimens formerly sold at several times these figures.

UTAH WARDITE AND VARISCITE.

Over 150 superb polished specimens are now in stock. So grand and varied a collection of these exquisitely beautiful specimens has never before been seen and probably never will be again. Few minerals light up a collection more than Utah **Variscite**.

GEORGIA RUTILES.

Our large stock of superb matrix specimens continues to command the admiration of every collector who honors us with a call or who kindly permits us to send him an approval shipment. No such rutiles are found in other localities.

Our "**FALL BULLETIN**" is now in preparation. 124 pp. **ILLUSTRATED CATALOGUE**, paper-bound 25c.; in cloth 50c. 44 pp. **ILLUSTRATED PRICE-LISTS**, 4c.; **Bulletins and Circulars** free.

GEO. L. ENGLISH & CO., Mineralogists,
64 East 12th St., New York City.

CONTENTS.

| | Page. |
|---|-------|
| ART. XXVIII.—Fractional Crystallization of Rocks; by G. F. BECKER..... | 257 |
| XXIX.—Eopaleozoic Hot Springs and the Origin of the Pennsylvania Siliceous Oölite; by G. R. WIELAND..... | 262 |
| XXX.—Conditions required for attaining Maximum Accu- racy in the Determination of Specific Heat by the Method of Mixtures; by F. L. O. WADSWORTH..... | 265 |
| XXXI.—Systematic position of <i>Crangopsis vermiformis</i> (Meek), from the Subcarboniferous rocks of Kentucky; by A. E. ORTMANN..... | 283 |
| XXXII.—New Species of the Palinurid-Genus <i>Linuparus</i> found in the Upper Cretaceous of Dakota; by A. E. ORTMANN..... | 290 |
| XXXIII.—Studies in the Cyperaceæ; by T. HOLM..... | 298 |
| XXXIV.—Improved Heliostat invented by Alfred M. Mayer; by A. G. MAYER..... | 306 |
| XXXV.—Pseudomorphs from Northern New York; by C. H. SMITH, JR..... | 309 |
| XXXVI.—Chemical Composition of Hamlinite and its Occurrence with Bertrandite at Oxford County, Maine; by S. L. PENFIELD..... | 313 |

SCIENTIFIC INTELLIGENCE.

Chemistry and Physics—Properties of Highly Purified Substances, SHENSTONE, 317.—Liquefaction of Fluorine, MOISSAN and DEVAR, 318.—Normal and Isopentane from American Petroleum. YOUNG and THOMAS: Heat of Combustion, MENDELÉEFF, 319.—Capillary constants of molten metals, H. SIEDENTOPF, 320.—Relations between the Geometric constants of a crystal and the Molecular Weight of its Substance, G. LINCK, 321.—Induction Coil in practical work, including Röntgen Rays, L. WRIGHT.

Miscellaneous Scientific Intelligence—British Association, 324.—Notes on Greenland glaciation, R. S. TARR: Revision of the Apodidæ, C. SCHUCHERT: New Meteorite from Canada, 325.—Observations on Popocatepetl and Ixtaccihuatl, O. C. FARRINGTON: L. Évolution régressive en Biologie et en Sociologie, J. DEMOOR, J. MASSART and E. VANDERNEUDE: Birds of Colorado, W. W. COOKE: Mammoth Cave of Kentucky: an illustrated Manual, H. C. HOVEY and R. E. CALL, 326.

Established by BENJAMIN SILLIMAN in 1818.

THE
AMERICAN
JOURNAL OF SCIENCE.

EDITOR: EDWARD S. DANA.

ASSOCIATE EDITORS

PROFESSORS GEO. L. GOODALE, JOHN TROWBRIDGE,
H. P. BOWDITCH AND W. G. FARLOW, OF CAMBRIDGE,

PROFESSORS O. C. MARSH, A. E. VERRILL AND H. S.
WILLIAMS, OF NEW HAVEN,

PROFESSOR GEORGE F. BARKER, OF PHILADELPHIA,

PROFESSOR H. A. ROWLAND, OF BALTIMORE,

MR. J. S. DILLER, OF WASHINGTON.

FOURTH SERIES.

VOL. IV—[WHOLE NUMBER, CLIV.]

No. 23.—NOVEMBER, 1897.

WITH PLATE XI.

NEW HAVEN, CONNECTICUT.

1897.

TUTTLE, MOREHOUSE, & TAYLOR, PRINTERS, 125 TEMPLE STREET.

Published monthly. Six dollars per year (postage prepaid). \$6.40 to foreign subscribers of countries in the Postal Union. Remittances should be made either by money orders, registered letters, or bank checks.

NOW READY!

A COMPLETE CATALOGUE

OF

MINERALS.

Nearly 150 pages with 40 splendid photo-engravings of new and interesting minerals.

CONTENTS.—I. Recent additions to our stock ; II. Collections of Minerals, both Economic and Scientific ; III. Complete Price List of minerals sold by weight for Chemical and Technical purposes ; IV. Meteorites ; V. Gems and Polished Specimens ; VI. Books, Geological and Mineralogical ; VII. Mineralogical Supplies ; VIII. Alphabetical Check List of all known Mineral Species, varietal names and synonyms, referring each name to the Dana Classification. Prices of Minerals in stock are given ; IX. General Classification of all known Minerals, according to Dana, giving number, name, form of each, with Composition in words and symbols. Varieties, sub-species and doubtful compounds, are given their proper position. To this is added an important and valuable Supplement, compiled from recent scientific literature, making the list complete to date ; X. **Metallic Classification of Minerals showing the various combinations in which the Metals occur in Nature.** The most complete table of the kind ever published.

See Sample Plates in Advertising Pages of this
Journal.

Bound in an odd and handsome cover, exhibiting throughout the finest examples of the photo-engravers' art, it makes an attractive volume and an invaluable work of reference.

Prices, postpaid: Bound in paper, 25c. ; cloth, 50c. ; calf, interleaved, \$1.00. (These figures barely cover cost of paper, binding and postage.) Catalogue of Collections, single specimens, etc., free.

A. E. FOOTE,

WARREN M. FOOTE, Manager.

1317 Arch Street, Philadelphia, Pa., U. S. A.

Established 1876.

THE

AMERICAN JOURNAL OF SCIENCE

[FOURTH SERIES.]

ART. XXXVII.—*On the Geology of Southern Patagonia*;
by J. B. HATCHER.

IT is the purpose of this paper to record such facts relating to the geology of southern Patagonia as were observed by the author during his explorations in that country from May 1st, 1896 to June 5th, 1897, while collecting vertebrate fossils for Princeton University; to offer a few suggestions as to the age and origin of the different sedimentary deposits and their stratigraphic relations to one another as displayed by sections in different parts of the region; and to make some remarks in regard to the agencies which have determined the present topographical features of the district visited.

Partly in order to assist others who may visit this country for the purpose of collecting fossils, but more especially for the purpose of facilitating the work of future investigators who may desire either to verify or disprove the correctness of my observations, I present here a sketch map of the Argentine territory of Santa Cruz (see p. 347), on which I have designated the most promising localities for vertebrate fossils observed by myself and my assistant, Mr. O. A. Peterson; and those places at which the stratigraphical sections accompanying this paper were made. It is believed that with the aid of this map it will be readily possible for anyone to identify all the more important localities mentioned in the text.

While my observations and conclusions are in many in-

stances quite different from, and in a few cases directly opposed to those of Dr. Florentino Ameghino and his brother Carlos Ameghino; yet it is believed that most of the conclusions reached are fully warranted by the facts observed; and that in the present paper there will be found an important supplement to our knowledge of this region, which has already been so much increased by the combined efforts of the brothers Ameghino.

Mesozoic Rocks.

Jurassic?—The oldest sedimentary deposits seen by the writer were a series of black, very hard, but much fractured slates, with Ammonites fairly abundant, but not sufficiently well-preserved to admit of identification. These beds, which I propose to call the *Mayer River beds*, in some places at least, rest directly on the eruptive rocks which here form the great mass of the Cordilleras; they are well represented on the right bank of the lower fork of Mayer River, just where it emerges from a deep gorge about three miles above its confluence with the main stream.* A greater development of these beds may be seen at the west end of Bald Mountain, an elevation in the middle of Mayer Basin; at this locality they have a decided eastwardly dip and an estimated thickness of 1500 feet. In their uppermost layers, they are sometimes of a red or yellow color and are less fractured and more cleavable than on Mayer River. No fossils were found on Bald Mountain.

The Mayer River beds are referred to the Jurassic, partly because of the Ammonites found in them, which appear to resemble Jurassic forms; but more especially on account of their lithological characters and because of the great thickness of the sedimentary rocks overlying them, which, by the presence of Dinosaurian remains in their uppermost strata, can hardly be more recent than Cretaceous.

Cretaceous.—Immediately, but unconformably, overlying the Mayer River beds, is a series of heavily bedded, light brown sandstones, becoming variegated above, exceedingly barren of fossils and with an estimated thickness of 1000 feet. In their lower layers they resemble in appearance the Dakota sandstones of our western States. They are well represented near the source of Mayer River, where they extend for several miles in an unbroken wall, forming the southern border of Mayer basin. With the exception of uncharacteristic plant impressions no fossils were found in these sandstones. They are referred to the Cretaceous upon stratigraphical evidences

* Many of the water courses and topographic features mentioned in this paper will not be found located on any of the current maps of Patagonia. For reference they have been located and given names on the accompanying map.

and are supposed to represent the variegated sandstones (*Areniscas abigarradas*) of Carlos Ameghino;* although both in this region, and on the upper Rio Chalia they appear to be unconformable with the overlying Dinosaur beds.

The Guaranitic beds.—Above the barren sandstones there is a series of variously colored sandstones and clays of immense thickness, not less than 2000 feet, and in which there occur in the greatest profusion the mineralized trunks of trees and, less frequently, Dinosaurian remains. Dr. Ameghino† has already called these beds the *Guaranitica beds* and referred them to the Upper Cretaceous upon the evidence afforded by the Dinosauria found in them. The Guaranitic beds are well represented on the head of Lignite creek on the south side of Mayer basin, and on the upper Rio Chalia; in both of these localities they are much tilted and have a general dip to the southeast.

The Pyrotherium beds.—I mention here the Pyrotherium beds and place them in the Cretaceous entirely upon the authority of Ameghino. In my work on the Upper Rios Chalia and Chico I was unable anywhere to identify the Pyrotherium beds or to find evidences of the rich mammalian fauna found in them by Carlos Ameghino. According to Dr. Ameghino these beds immediately overlie the Dinosaur beds and pass insensibly into them.‡ No difficulty whatever was experienced in determining the Guaranitic beds and in finding Dinosaurian remains in them. I searched faithfully these Dinosaur beds from the base of the marine Tertiary above to the barren sandstones below for mammal remains, but *without the slightest success*. I never found in position in the Dinosaur beds a single mammal bone or tooth. I did find mammal remains in this region which seem to pertain to the genus Pyrotherium, but they belong to a horizon much more recent than the Guaranitic beds or even the Patagonian beds, and should not be placed lower in the geological scale than Miocene, for they are above the Supra-Patagonian beds of Ameghino. I present here in fig. 1 an incisor tooth, No. 15101 in our collection, which from its size and shape appears to agree pretty closely with the incisors of Pyrotherium. Only part of that portion projecting from the jaw is preserved and this is nine inches in length and nearly three inches in greatest diameter.

* See "Note on Geol. and Pal. of Argentina," Geol. Mag., Jan., 1897, p. 5, and Bol. Inst. Geografica Argentina, vol. xvii, 1896, pp. 87-108, and C. Ameghino, "Expl. Geol. en la Patagonia," Bol. Inst. Geografica Argentina, vol. xi, 1890, pp. 1-46.

† See F. Ameghino, "La Argentina al Traves de las Ultimas Epocas Geologicas;" Imprenta de pabla E Coni e Hijos, Buenos Aires, 1897, p. 33.

‡ F. Ameghino, Note on Geol. and Pal. of Argentina, Geol. Mag., London, January, 1897, pp. 4-20.

It was found associated with the remains of other mammals, birds and small reptiles. From the stratigraphic position of the beds in which this tooth and the associated fossils were

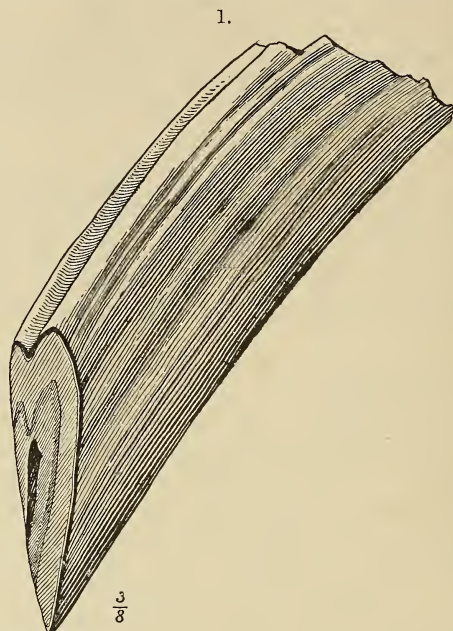

FIG. 1, right sup. incisor of *Pyrotherium*? three-eighths natural size.

found I did not suspect that they were in any way related to the *Pyrotherium* beds and spent very little time in them.

I seriously question the stratigraphic position of the *Pyrotherium* beds as determined by the brothers Ameghino, although it may seem presumptuous on my part, since I was unable to identify the beds at all, and the explorations, travels and opportunities for observations in this region of Señor Carlos Ameghino have been far more extensive than have my own. It is certainly remarkable that in these beds containing Dinosaurian remains, associated according to Ameghino with the remains of mammals, some of them, as for example *Pyrotherium* of *immense* size, only a little less than that of the elephant and consequently easily to be seen, I could have searched for weeks without ever finding a single mammalian bone, while every day I found Dinosaurian remains.

Considering the immense size and highly specialized character of many, in fact of most of the mammals described by Ameghino from the *Pyrotherium* beds, it does not seem possible that they could have lived in Cretaceous times and coex-

isted with the Dinosaurs of that period. From a study of the figures and descriptions published by Dr. Ameghino of the fossils found in the Pyrotherium beds, one is even led to believe that they may belong to a period more recent than that of the Santa Cruz beds. I present here in fig. 2, taken from one of Ameghino's latest publications, the superior dentition of *Morphippus imbricatus*, one of the smaller ungulates described by him as coming from the Cretaceous of Patagonia.

2.

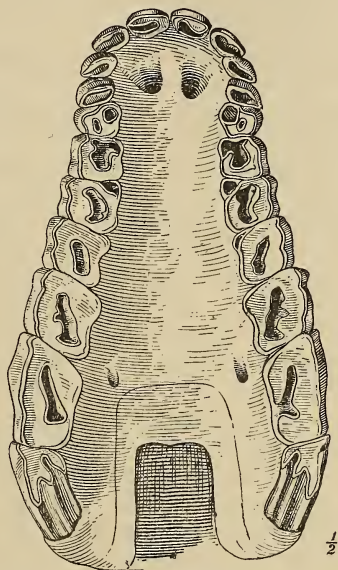

FIG. 2. Sup. dentition of *Morphippus imbricatus* Amegh., after Ameghino. One-half nat. size.

The entirely molariform condition of the premolars and the cupped incisors are especially noteworthy. In his "Notes on the Geology and Paleontology of Argentina" previously referred to, he says on page 8, in speaking of the Pyrotherium fauna, "The unarmored edentates are also numerous and of types resembling those of the Santa Cruz formation, but generally of much more considerable size. Nevertheless some forms show very primitive characters, having the molars provided with a well developed layer of enamel.

"With these edentates there are Carnivorous animals of a size approximating to that of the largest bears of the present day, but similar to those of the Santa Cruz formation." This is certainly a greater size than that attained by any of the Carnivorous animals of the Santa Cruz beds. Moreover many of

the ungulates described by Ameghino as from the Pyrotherium beds are larger than the allied forms in the Santa Cruz beds. Now as regards structure and specialization of parts we are as yet unable to judge in many cases just which forms are the more specialized. In not a few instances, in his descriptions of remains from the Pyrotherium beds, he shows that they are not distinguished either generically or specifically from allied forms in the Santa Cruz beds, sometimes that they are decidedly more specialized than the latter, and almost always that they are of a size and structure showing a close relation with the fauna of the Santa Cruz beds and not at all what we should expect from the Cretaceous. As instances of this I may cite that in his "Première Contribution à la Connaissance de la faune Mammalogique des Couches à Pyrotherium" on page 44, in closing his description of *Asmodeus Osborni* he remarks, "Cet animal est assurément un des plus gros mammifères qui ait foulé la surface de la terre." Again on page 50 in defining the genus *Ancylocœlus*, he compares it with *Homalodontotherium*, a closely allied genus from the Santa Cruz beds but which is distinguished from the latter partly by the dental formula, which he finds to be $I\frac{3}{3}C\frac{1}{1}P\frac{4}{4}M\frac{3}{3}$ in *Homalodontotherium*, while in *Ancylocœlus* from the Pyrotherium beds there is a reduction in the number of inferior premolars to three on either side, a marked advance over the Santa Cruz form. On page 56 he mentions edentates from these beds of the stature of *Myloodon*. Many other similar examples might be cited, but enough has been done to show that we are not dealing with a Cretaceous fauna. Thus, from his own figures and descriptions it would appear that in the matter of size at least, there is a *decided* advantage in favor of forms found in the Pyrotherium beds as compared with related forms from the Santa Cruz beds. In the history of the development of every mammalian phylum in the northern hemisphere, so far as I am aware, there is a decided and gradual increase in the size of the individual from the lower to the higher forms. According to Dr. Ameghino, exactly the opposite has taken place in South America. It would be interesting to know why it is that natural causes always working by the same methods have produced such opposite results in the two hemispheres, when as is everywhere shown, especially among the ungulates there are such marked cases of parallelism in structural development.

Whatever may be the relation of the Pyrotherium beds to the Santa Cruz beds, I feel sure that the mammalian fauna described by Florentino Ameghino as from the Pyrotherium beds does not occur associated with the Dinosaurian remains of the Guaranitic beds, unless such association is due to secondary deposition of the latter or a superficial mingling of

remains from two or more distinct horizons by recent erosion; which latter has been the cause of much confusion in other instances, as for example, the Loup Fork and Equus beds of our western plains.

Dr. Ameghino,* in giving his reasons for referring the Pyrotherium beds to the Cretaceous, says: "I rely on the fact that these beds with remains of Pyrotherium everywhere accompany the red sandstones with remains of Dinosaurs, so that it has not hitherto been possible to separate them in an absolute manner. These sandstones in certain places exhibit nothing but bones of Dinosaurs; in others they show only remains of mammals and small reptiles of types not yet determined, while at other points all these remains are shown mixed together, at least to *all appearance* (italics mine), always accompanied by a great quantity of silicified wood." Now according to Ameghino's own statements, in the localities where this Pyrotherium fauna has been found most abundantly, the nature of the country is just such as to bring about a mingling of remains really belonging to quite different horizons, and thus their association in the same horizon may be only *apparent*, as he himself has in reality suggested. In another publication† he says: "Malheureusement ce nouveau gisement se trouvait dans une région absolument inconnue et accidentée d'une manière épouvantable; il s'égara au milieu de ce labyrinthe et ne put en sortir qu'à dure peine en abandonnant une partie du matériel de voyage." I may also add that in the region of Mayer basin and the upper Rio Chalia, especially the former, there have been great disturbances, so that the Guaranitic beds and the superimposed Tertiary deposits are inclined at high angles. In such a region the exact stratigraphic relations of the different beds are not always easily determined, and in some cases grave errors have arisen through false determinations made by most capable men. As an example of this, it need only be remembered that Señor Carlos Ameghino spent five years in Patagonia, working mostly in the Santa Cruz beds, before discovering that they overlie the Patagonian beds,‡ all the while considering them as below the latter series (although Darwin had fifty years before suggested the true conditions),§ and this far out from the mountains and in a region singularly free from faults or dislocations of any kind, where the strata are approximately horizontal and succeed one another in regular order.

* Loc. cit.

† See Première Contribution à la Connaissance de la Faune Mammalogique des Couches à Pyrotherium. Florentino Ameghino, Bol. del Inst. Geo. Arg., tome xv, cahiers 11 et 12.

‡ See Énumération Synoptique des Espèces de Mammifères Fossiles des Formations Éocènes de Patagonie, par Florentino Ameghino. Buenos Aires 1894, pp. 1-8.

§ See Geol. Observ. on South America, p. 117.

It is true that Dr. Florentino Ameghino states that the variegated sandstones of the interior extend to the Atlantic coast, and are covered in concordant stratification by the same strata with *Pyrotherium*; but since he gives no localities and nowhere describes any remains of *Pyrotherium* or other mammals from those beds as having been found at San Julian or other localities on the coast, the correct identification of those beds as *Pyrotherium* may well be questioned.

I have dwelt at some length upon the question of the age of the *Pyrotherium* beds because of the importance of the problems involved. If the beds containing this remarkable mammalian fauna be really Cretaceous, not only may the value of vertebrate fossils as means of correlation be seriously questioned, but a very decided blow will also be struck at the validity of all correlations based on paleontological evidences, whether of vertebrates, invertebrates or plants.

Until this entire region has been carefully explored and the stratigraphic position of the *Pyrotherium* beds accurately determined, by men trained in stratigraphic work, the question of their exact position in relation to the Dinosaur beds and to the different Tertiary beds, as well, will remain unsettled in the minds of most vertebrate paleontologists.

Tertiary Deposits—Eocene.

The Patagonian beds.—Extending along the Atlantic coast in an almost unbroken succession from New Bay on the north to near the mouth of the Coy River on the south, there is a series of light-colored, well stratified sandstones and clays, usually quite soft but sometimes, especially in the sandstone layers, enclosing very hard, lenticular concretions. These beds are known as the Patagonian beds, and the typical locality for them may be considered as the Atlantic coast anywhere from Port Desire to the mouth of the Santa Cruz River. They attain to a thickness of several hundred feet, are of marine origin and are everywhere characterized by marine invertebrates in great abundance. In the region south of Port Desire they dip very gradually to the southeastward, so that their uppermost strata disappear beneath the waters of the Atlantic about midway between the Santa Cruz and Coy Rivers.

In regard to the age of the Patagonian beds there has been great difference of opinion, but most persons acquainted with them and with the invertebrate fauna found in them agree in referring them to the Eocene. Dr. Ameghino, in discussing this question, says:* “The fact is that the Patagonian formation begins with the Upper Cretaceous, but acquires its great-

* See Notes on Geol. and Pal. of Arg., p. 12.

est development during the Eocene. The fossiliferous deposits of Quiriquina were at first regarded as Tertiary, and were only assigned to the Cretaceous after there had been discovered in them remains of *Plesiosaurus* (*Cimoliosaurus*) *chilensis*, of *Ammonites*, and some other Secondary genera.

“The late Cretaceous formation of the coast of Chili exhibits absolutely the same aspect and the same lithological characters as the Patagonian formation. The facies of the fauna is equally the same, since the Cretaceous fauna of Quiriquina only differs from the fauna of the Patagonian formation by the presence of eight genera (*Ammonites*, *Hamites*, *Baculites*, *Pugnellus*, *Cinulia*, *Pholadomya*, *Monopleura*, *Trigonia*), which are not met with in this latter; while 85 per cent, more or less, of the genera of the Cretaceous formation are also found in the Eocene Patagonian formation. Moreover according to Philippi, the best authority on the subject, 20 per cent of the species of shells of the Cretaceous formation of Algarroba are likewise species of the Patagonian formation, and it will be recognized that in Patagonia the marine Cretaceous and Eocene formations pass from one to the other in a gradual and insensible manner.”

Granting that the facts as stated above are correct, and Dr. W. Moericke* has shown that considerable doubt exists as to the above association of species at the localities mentioned, they do not justify Dr. Ameghino's conclusion that the Lower Patagonian beds belong to the Upper Cretaceous; for in regard to the eight genera mentioned above as found only in the Cretaceous of the west coast and not in the Patagonian beds, it should be remembered that of these, six are characteristic of the Mesozoic, and are unknown in any deposit later than Cretaceous, while the two remaining, *Pholadomya* and *Trigonia*, are found indiscriminately from the Lias to recent times. The per cent of genera or even of species common to the two deposits is of less importance than the character of the genera and species peculiar to each. Now six of the eight genera found in the Cretaceous deposits of the west coast and absent in the Patagonian beds are typical Mesozoic genera, while most of those genera found only in the Patagonian beds are unknown from the Cretaceous, and the greater number of genera common to both have been found in different localities throughout the world in both Secondary and Tertiary deposits, and are therefore unimportant in determining the age of either series of beds. If the Lower Patagonian beds really belong to the Cretaceous, since they are of distinctly marine origin, we should find in them some trace of that unusually prolific Cephalopod fauna (*Ammonites*, *Hamites*, *Scaphites*, *Baculites*,

* Neues. Jahrb., etc., Beil. Bd. x, 1896, p. 594.

etc.) the remains of which are everywhere so abundant in all the known marine Cretaceous deposits of the world, but which are singularly wanting in the Patagonian beds. Since there has not been reported up to the present time a single species characteristic of the Cretaceous period from the *typical* Patagonian beds on the east coast of Patagonia, and since the entire faunas of the fauna is Tertiary, there is no good reason, from a paleontological standpoint, for referring any part of this formation to the Cretaceous.

The arguments advanced by Dr. Ameghino for assigning the Lower Patagonian beds to the Upper Cretaceous on account of certain remains of Mosasaurs, Plesiosaurs and fish of Cretaceous types found in the vicinity of Lake Viedma, are of little value, since those beds have never been properly identified as the Patagonian beds.

The stratigraphical evidences in favor of referring the whole of the Patagonian beds to the Tertiary appear to be quite conclusive, assuming that the Guaranitic beds are Upper Cretaceous. That there was a considerable lapse of time between the close of the deposition of the one, and the beginning of that of the other, series of deposits is evidenced by the altered nature of the materials, which show not only that they were derived largely from different sources, but that they were deposited in the one instance in fresh water and in the other in salt water over identically the same geographical districts. Again the appearance of the Guaranitic beds, on the coast at San Julian, where there are no disturbances in the Patagonian beds, can best be accounted for by assuming that they represent a prominence in those beds, due to erosion, which took place after the close of the deposition of the Guaranitic beds and prior to the deposition of the Patagonian beds. Moreover in vast areas, throughout the interior, the Guaranitic beds are immediately overlaid by formations much more recent than Patagonian, thus showing a decided unconformity by overlap between the two series. No interstratification of the two series has ever been observed, which would have been the natural result had they been deposited simultaneously and had marine and fresh-water conditions prevailed at the same time in adjacent regions.

Most of the confusion which has arisen regarding the age of the Patagonian beds, has doubtless been due very largely to the carelessness of collectors. For many years every fossil-bearing horizon discovered anywhere in southern South America and containing a large oyster, was referred without question to the Patagonian beds, and collections were made indiscriminately at many different localities and from many different horizons from the Upper Cretaceous to the Pliocene, all referred to the Patagonian beds and placed in the hands of specialists for

study, often with no other remark than that they were from the Patagonian beds. In this manner, for years, the fauna of the Patagonian beds has been made to include everything from the Upper Cretaceous deposits of the west coast to the Supra-Patagonian beds, the beds in Entre Rios on the Parana and, very likely, some forms from the Cape Fairweather beds of Pliocene age. It is therefore not surprising, in view of this unwarranted association of fossils, that the opinions of conchologists should have varied so much in regard to the age of these beds.

What is especially needed, is a complete series of the invertebrates from the typical localities at the mouth of the Santa Cruz and Desire rivers and the intervening coast, for study and comparison with forms from horizons in both Europe and North America, the age of which has been accurately determined from stratigraphical evidences. With this end in view we made a small collection from near the mouth of the Santa Cruz River, which has been placed in the hands of Dr. A. E. Ortmann, who considers them as not older than Eocene and has thus far identified the following genera and species: *Ostrea hatcheri* (Ort.); *Cucullæa alta* (Sow.); *Pecten* sp.?; *Perna* sp.?; *Arca* sp.?; *Limopsis insolita* (Sow.); *Limopsis aff. araucana* (Phil.); *Cardita patagonica* (Sow.); *C. inaequalis* (Phil.); *Venus meridionalis* (Sow.); *V. volkmanni* (Phil.); *Glycimeris* sp.?; *Dentalium majus* (Sow.)?; *Trochus laevis* (Sow.); *Turritella ambulacrum* (Sow.); *Turritella affinis* (Hup.); *Crepidula gregaria* (Sow.); *Natica obtecta* (Phil.); *Struthiolaria ornata* (Sow.); *Ficula carolina* (d'Orb.); *Voluta* sp.?; *Fusus darwinianus* (Phil.); *Cancer patagonicus* (Phil.).

Incomplete as this collection doubtless is, yet it may be regarded as typical of the beds in question. It is hoped that we may soon be able to make more extensive collections from these beds, but from the evidence already at hand there seems no good reason for referring any part of the Patagonian beds to a more remote age than Eocene.

Miocene.

The Supra-Patagonian Beds.—After the deposition of the Patagonian beds this region was for a considerable period elevated above the level of the sea and subjected to erosion, and doubtless much of the material composing the Patagonian beds was then completely removed over large areas, especially in what is now the interior region. This period of erosion was of sufficient duration to accomplish great changes in the marine fauna of the regions; for in the succeeding strata, which are also of marine origin, there is almost a completely new list in the species represented, while several new genera have been

introduced, and the entire aspect of the fauna changed from Eocene to Miocene, according to Dr. Ortmann, who has also studied our collections of invertebrates from these beds and has identified the following forms: *Cidaris* sp. ?; *Scutella* sp. ?; *Bryozoa*; *Terebratula patagonica* (Sow.); *Ostrea phillippii* (Ort.); *O. hatcheri* (Ort.); *Pectunculus* sp. ?; *Glycimeris* sp. ?; *Fissurella*; *Solarium*; *Trochita costellata* (Phil.); *Turritella affinis* (Hup.); *Crepidula gregaria* (Sow. ?); *Scalaria rugolosa* (Sow.); *Struthiolaria chilensis*; *Natica solida* (Sow.); *Balanus varians* (Sow.); *Chthamalus antiquus* (Phil.).

The Supra-Patagonian beds are composed of alternating layers of sandstones and clays, usually of a yellow or light brown color with a rich invertebrate fauna. Ameghino states that they have a thickness of 30 meters, but in the interior, along the base of the Cordilleras, they certainly attain to a much greater thickness, and I should not hesitate to allot to them a thickness of fully 150 meters at Shell Gap, where Lignite Creek emerges from Mayer basin. In this region, as also on the upper Rio Chalia, they rest unconformably upon the Guaranitic beds and dip to the eastward at an angle of about 15° as shown in fig. 3.

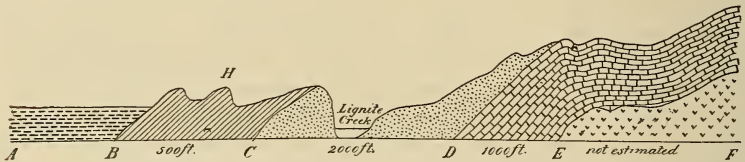

FIG. 3. Section of sedimentary deposits as displayed on south side of Lignite Creek and southern border of Mayer basin, from a point one mile east of Shell Gap to the western border of the basin. A-B. Fresh-water, Santa Cruz beds; B-C. Marine Supra-Patagonian beds; C-D. Fresh-water? Guaranitic beds; D-E. Barren sandstones; E-F. Marine Mayer River beds and igneous rocks. Distance from A to F about 15 miles. Relative inclination of strata to base-line. A-F. exaggerated for effect, thus increasing thickness of deposits relatively to length of section displayed.

The Santa Cruz beds.—I cannot agree with Dr. Ameghino in considering the Santa Cruz beds as belonging to the same series with the Supra-Patagonian beds. My reasons for separating them are because the Santa Cruz beds are of fresh or brackish water origin, as shown by the diatoms which they contain;* and also I am brought to this conclusion by the fact that all along the foot hills of the Cordilleras the Supra-Patagonian beds were observed, inclined at high angles, while in the same region the Santa Cruz beds are approximately horizontal and show almost no evidences of disturbance. At Shell Gap, on Lignite Creek, this creek has cut a narrow gorge through the sandstones and clays of the Supra-Pata-

* See Geol. Obs. on S. A., by Darwin, p. 117.

gonian beds, which are here inclined at an angle of not less than 15° , while not more than one-half mile below, on the right bank of the same stream, may be seen an outcrop of sandstones of the Santa Cruz beds, which appear nearly horizontal. In fact, so far as I was able to determine, the inclination of the Santa Cruz beds is nowhere appreciable, except at certain points along the water courses, where it is possible to take in at one view stretches of several miles of the strata, and then there is apparent only a very gentle dip to the southeast.

I nowhere found mammals in the marine beds, nor did I anywhere find the two series interstratified. I observed the contact between the two series at many different localities and did occasionally find bones below the base of the Santa Cruz beds, but they were such as had fallen down from above. On one or two occasions I found bones in strata which were absolutely lower than other strata in the same vicinity where marine invertebrates were abundant, and I at first believed that there had been an interstratification of the two series, but upon careful examination, I found that the layer with the invertebrates did not continue on so as to actually overlie that with the bones, and I was brought to the conclusion that the Santa Cruz beds had here been deposited upon the eroded surface of the Supra-Patagonian beds. An example of this may be seen in a small cañon on the south side of the Rio Chico about two miles below Sierra Oveja. In going up the valley of Chico River it is impossible to be mistaken as to the old crater (*Sierra Oveja*), since it rises directly from the bank of the stream and compels one, if traveling with a vehicle, either to cross the river or go around to the west of the mountain, neither of which routes is particularly good. About two miles below this crater there enters the river valley from the west a narrow, deep cañon. Ascending this cañon some 200 yards, there appears on the south side of it a projecting sandstone ledge, about two feet thick, with an abundance of oyster shells. Proceeding a little farther, the cañon is seen to open out into a small, deeply eroded, "bad land" basin. Continuous all the while on your left is the oyster-bearing, sandstone ledge, which, at a distance of about one-half mile from the mouth of the cañon, becomes covered by talus: this condition continues for perhaps 100 yards, when the section is again clear, and in the lowermost layers there are mammal remains, while the sandstone layer with its oysters is nowhere to be found. It is true that the bottom of the cañon has been all the time rising, but the elevation did not appear sufficient to bring the shell-bearing layer below its surface; I therefore concluded that the sandstone layer with oysters had been eroded away before the deposition of the mammalian beds.

From the high angle of inclination of the Supra-Patagonian beds all along the eastern base of the mountains, it is evident that at the close of that period there were great orographic movements throughout southern South America. Not only were the Cordilleras greatly elevated, but also the region to the eastward, far beyond the present limits of the Atlantic coast, was brought above sea level. The eastern border of this great land mass was perhaps not far to the eastward of the Falkland Islands, and may be approximately represented by an imaginary line connecting these islands with certain outlying bodies of Primary Rock at Port Desire, and other places farther north, and perhaps extending also in a southeasterly direction as far as South Georgia Island. The great development of the Santa Cruz beds along the coast, especially between the Coy and Gallegos Rivers, as well as the very shallow nature of the water between that coast and the Falkland Islands, are both important evidences of a much greater eastward extension of the land during the Santa Cruz period than at present.

Consequent upon the elevation which took place at the close of the Supra-Patagonian period, there was between the borders of the old land-mass, now represented on the east by the Porphyries of Port Desire, and by the Falkland Islands; and on the west by the Cordilleras, a depression, in which were laid down the fresh-water, lacustrine deposits, now known as the Santa Cruz beds, and containing one of the richest and most varied vertebrate faunas known. That the Santa Cruz beds are of fresh-water origin rather than marine is shown by the diatoms. It is also clear from the nature and composition of the strata, that they were not deposited in a great, continuous lake, but rather in a low, flat, marshy country with smaller lakes and connecting water courses. As evidences of this I would cite the numerous examples of cross-bedding, and the fact that the beds of sandstones, clays and conglomerates continually replace one another, both of which facts are well shown in fig. 6 at G and J, and in figures 10 and 11.

The Santa Cruz beds may be separated, according to the vertebrate remains found in them, into an upper and lower horizon. The strata of the lower Santa Cruz beds, as compared with those of the upper, are of a lighter color, more continuous and are composed of finer materials, containing few or no conglomerates. They are best displayed in the bluffs of the Santa Cruz, and of the upper Chalia and Chico Rivers, where they are characterized by the great numbers of herbivorous marsupials and gigantic birds found in them. The upper Santa Cruz beds are best exhibited in the bluffs of the sea and the Gallegos River from Coy Inlet to Guer Aike,

where they are characterized by the scarcity of herbivorous marsupials and bird remains and the abundance of the remains of carnivorous marsupials, edentates, ungulates, rodents, etc.

There has been much doubt in regard to the age of the Santa Cruz beds. Darwin* was the first to determine that they were distinct from the Patagonian beds and to suggest their true stratigraphic position in regard to the latter. Dr. Florentino Ameghino† and his brother Carlos Ameghino, during the first five years of their labors on the mammalian fauna of the Santa Cruz beds, supposed them to underlie the Patagonian beds which most conchologists agree in referring to the Eocene. They therefore considered the Santa Cruz beds as Lower Eocene and the Patagonian beds Upper Eocene. Finally on his sixth journey into this region Carlos Ameghino was able to determine the exact stratigraphic relations of these deposits, and their relative position in the Tertiary scale was exactly reversed.

So far as any observations bearing upon the stratigraphic relations of the Santa Cruz beds are concerned, there is absolutely nothing against referring to them any age from Lower Miocene to Lower Pliocene. That they are not older than Middle Miocene is pretty clearly shown, since they have been seen to rest unconformably upon the Supra-Patagonian beds, in regard to the invertebrate fauna of which Dr. Ortmann writes as follows: "The most interesting form of the Supra-Patagonian beds is the *Scutella*. According to Zittel (*Handbuch der Palaeontologie*, vol. i, p. 522), all the species of *Scutella* are found in the Oligocene and Miocene; so that this fact tends to confirm Moericke's opinion (*N. Jahrb. Min.*, etc., Beil. Bd. x, pp. 593 and 596) of the Miocene age of the Patagonian beds, at least of a part of the so-called Patagonian beds. If this is true, the Santa Cruz beds overlying the *Scutella* beds cannot be Eocene."

In any attempt to correlate the Santa Cruz beds with other Tertiary strata of either Europe or North America, nothing will be found of more value than the remarkable vertebrate fauna which they contain. There is absolutely no ground, from a stratigraphical standpoint, for presuming that the mammalia of this region were any more advanced in early Tertiary times than were the mammalia of the northern hemisphere; hence, notwithstanding the fact, that the Santa Cruz fauna is so dissimilar to any known in either Europe or North America, if among the ungulates, rodents and other orders common to

* See Geol. Obs. on S. A., Darwin, p. 117.

† See Énumération Synoptique des Espèces de Mamifères Fossiles des Formations Éocènes de Patagonie, par Florentino Ameghino, pp. 4-5 (Buenos Aires), 1894.

both, forms are found, no matter how dissimilar they may be, yet showing approximately the same degree of development along those lines of progression common to both, it is only fair to consider beds containing such forms as of approximately the same geological age, and such correlation of the deposits of Patagonia will, it is believed, receive the sanction of most paleontologists and geologists, until good reasons are produced to show that it is at fault. It was largely for the purpose of securing material with which to make such comparisons that our expedition to Patagonia was undertaken. Several tons of most excellent fossils were procured from various horizons in the Santa Cruz beds, among which are the skulls and greater portions of the skeletons of nearly every genus reported from these beds. This material is being rapidly freed from the matrix and prepared for study, and in a short time it will be possible to compare these forms, point for point, with the skeletons of animals found in our own Tertiary deposits, the age of which has been determined beyond reasonable doubt, both from paleontological and stratigraphical evidences. While the final results of such comparisons are yet to be attained, enough has already been done to demonstrate the comparatively modern aspect of the fauna of the Upper Santa Cruz beds. For the benefit of those interested and who may not have had an opportunity of studying for themselves the figures and descriptions already published by Dr. Ameghino, I present here in figs. 4, 4a, 5, the metatarsals and superior dentition of one of the Protheroheridæ, drawn from part of No. 15107 in our collection. Note the complex structure of the molars and pre-molars, the molariform condition of the latter, the long diastema, the absence of incisors, etc., in the dentition, while in the metatarsals there is the very great tendency to monodactylism, as shown by the rudimentary character of metatarsals II and IV, and the extremely well-developed metapodial keel on metatarsal III. These or other characters, equally indicative of a high degree of specialization, are met with in nearly every group of animals in these beds. In consideration of the stratigraphic position of the Santa Cruz beds and the degree of specialization exhibited by the mammalian remains found in them, it is difficult to see how they can pertain to a period more remote than Miocene.

Pliocene.

The Cape Fairweather beds.—In this Journal for September last, the author described and gave a section of certain marine deposits found near Cape Fairweather, overlying the Santa Cruz beds, and named them the *Cape Fairweather beds*. At

that time I had not seen Dr. Ameghino's article entitled "Notes on the Geology and Paleontology of Argentina,"* in which he gives the first notice of marine deposits, found in this region, overlying the Santa Cruz beds. My observations regarding the relations of these marine beds to the Shingle formation (*Tehuelche formation of Ameghino*) do not agree with those of Señor Carlos Ameghino. Dr. Ameghino, on page 17 of the paper just cited, after quoting at some length from a letter from Carlos Ameghino, concludes: "According to this the boulders were deposited at the bottom of the sea,

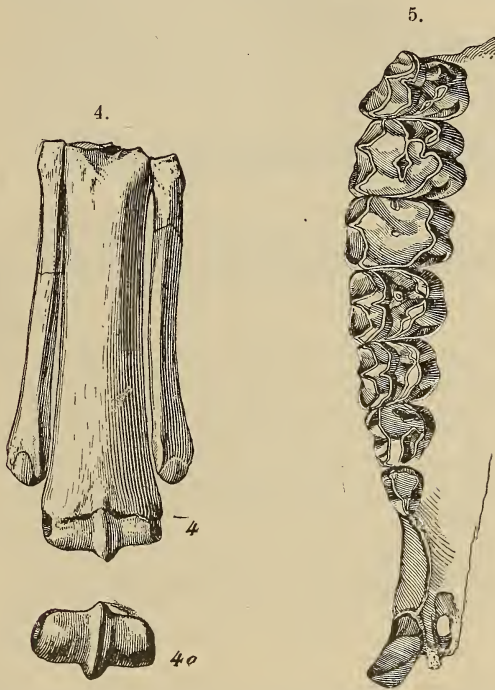

FIG. 4. Front view of metatarsals of *Diadiaphorus majusculus?* Amegh. from No. 15107 Princ. col. fig. 4a: view of distal end of metatarsal III, showing great development of metapodial keel.

FIG. 5. Crown view of sup. dentition of *Diadiaphorus majusculus?* Amegh. from No. 15107, Princ. col.

and over them there extended at other periods a vast formation of marine shells, of which there only remains diminished traces at certain definite spots." This is exactly the opposite of what I observed near Cape Fairweather on the coast, where there is a splendid continuous section from the Shingle formation through the Cape Fairweather beds and some 300 feet of

* See Geol. Mag., January, 1897, pp. 4-20.

the Santa Cruz beds, and where it is absolutely impossible to mistake the relative position of the series of deposits. As shown in the section given in my original description of these beds, and reproduced here in fig. 6, the beds with marine invertebrates underlie the Shingle formation.

6.

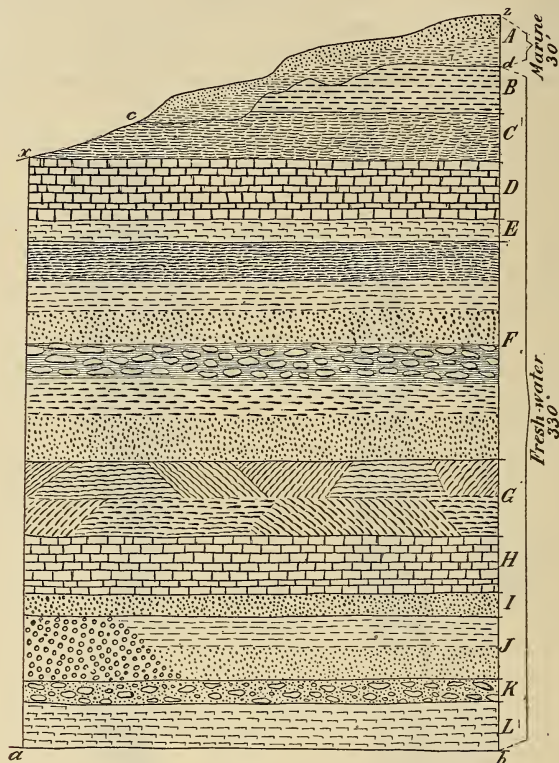

FIG. 6. Section near Cape Fairweather showing relations between Cape Fairweather and Santa Cruz beds. *b-d*. Santa Cruz beds. *d-z*. Marine beds, consisting below of Cape Fairweather beds and above of the boulder formation. *c-d*. Contact between Cape Fairweather and Santa Cruz beds.

I provisionally correlated the Cape Fairweather beds with certain deposits discovered by Darwin at San Sebastian Bay on the east coast of Tierra del Fuego. Until the fauna of the latter beds is known, it will be impossible to verify the accuracy of this correlation. The aspect of the very meagre fauna found in them by Darwin, as well as the very considerable increase in thickness to which they attain at San Sebastian, are both important evidences in favor of this correlation; for as mentioned in my previous paper, all the Tertiary deposits of

this region increase in thickness as we proceed southward along the coast, and appear first toward the north capping the summits of the higher table lands, then farther south they are brought to the water's level by a slight southeasterly dip, and finally, still farther south, they entirely disappear beneath the sea.

In discussing the age of these marine beds Dr. Ameghino refers them to the Miocene because they contain oysters "of large size and of a species similar to that characterizing the Santa Cruz formation." Prof. Henry A. Pilsbry, who has studied our first collections from these beds and already published in the Proc. of the Phil. Acad. of Sci. a list, with descriptions of new species, refers these beds to the Pliocene. He has furnished me the following list of species: *Trophon laciniatus* Martyn, *T. inornatus* Pilsbry, *Calyptræa mammillaris* Brod. (?), *Turritella innotabilis* Pilsbry, *Cardium* sp. indet., *Pecten actinodes* Sowb., *Ostrea ferarresi* Orb.,* *O. n. sp.*, *Pinna* sp. indet., *Magellania venosa* Sol. Of these he remarks "*Trophon laciniatus*, *Magellania venosa* and the *Calyptræa* are living species. The *Cardium* and *Pinna* may also be living. The others are extinct, but the *Turritella* is closely allied to a living Chilian form." We have since sent Dr. Pilsbry additional material which will enable him to nearly double the list of species, and which, he says, only confirms the Pliocene age of the beds.

The Tehuelche or Shingle Formation.—The presence of the Cape Fairweather beds with an abundant marine fauna, above the Santa Cruz beds, is positive proof of the submergence of this region. That this submergence took place long after the close of the Santa Cruz period can, I think, be well demonstrated, for, as shown in fig. 6, the Cape Fairweather beds are seen to rest upon the eroded surface of the Santa Cruz beds. This unconformity by erosion cannot be considered as due to a secondary deposition of the materials of the Cape Fairweather beds on the surface of the slope of the cañon where the section was made, for the two strata of bowlders and sandstones are here quite distinct, and show no mingling of materials, such as would have resulted from secondary deposition. Moreover the same unconformity is observable a little farther north in a section exposed for a long distance and where an absolutely level plain prevails above, as shown in fig. 7.

From these facts and others to be mentioned later, I conclude that after the deposition of the Santa Cruz beds and prior to the deposition of the Cape Fairweather beds this region was for a considerable period above sea level and subjected to erosion; during this period of erosion all the more

* In regard to the identification of the large oysters of Patagonia see paper by Dr. A. E. Ortmann in this number of this Journal, p. 355.

important water courses and many of the minor ones, which now exist, were outlined. After this, there was a subsidence sufficient to cause a submergence of this region beneath the sea, which prevailed in Pliocene times for a period ample for the deposition of the Cape Fairweather beds. Toward the close of the Pliocene there began a gradual elevation of this

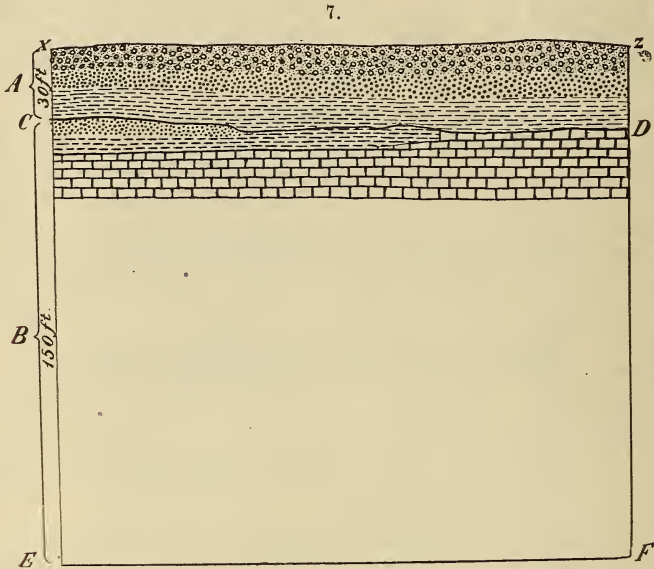

FIG. 7. Section showing unconformity by erosion between Cape Fairweather and Santa Cruz beds, made from top of land slide just north of section shown in fig. 6. B. Upper 150 feet of S. C. beds; A. Marine C. F. beds, composed below of sandstones with marine invertebrates and above of boulder formation.

area, during which the great boulder formation was deposited by the combined action of ice and water, and which resulted in bringing this region permanently above sea level. There can be little doubt that the origin of the numerous small salt lakes which now occur all over this region, and which occupy depressions in the surface of the plains, frequently several hundred feet in depth, dates from this period, and that they are due to confined bodies of salt water left in these depressions by the receding sea. Such depressions were, at some period during the elevation of this area, bays, formed usually near the source of small drainage channels tributary to the more important water courses, which existed in the former period of erosion. Across the mouths of these shallow bays there were thrown, by the tides, bars composed of sand and shingle which, as the elevation continued, confined considerable bodies of sea-water. If in such a body of water the loss by evaporation exceeded the gain by tributaries, there would be a gradual decrease in the

I have already stated that the deposition and distribution of the great bowlder formation was accomplished by the combined action of water and ice. The facts which have led to this conclusion are the great quantity of material left as rounded hillocks, composed of heterogeneous masses of angular rocks, often of great size, polished bowlders and much fine-grained, silted material, occurring as moraines all along the base of the mountains and sometimes extending for some distance out on the plains. Another fact also observed and bearing directly upon this question is the distribution throughout this formation of immense bowlders, which could not possibly have been transported to their present position by any other agency than that of ice. The number of these large, massive bowlders rapidly decreases to the eastward after reaching a point about thirty miles east of the Cordilleras, but they are found, though rarely, even as far east as the present coast. As an instance of this I may mention that one of these bowlders, weighing several thousand pounds, may be seen on the bluffs of the south side of the Rio Chico about ten miles below the mouth of Rio Chalia. It lies on the north side of and only a few yards from the road which leads from the port of Santa Cruz to the settlements on the lower Rio Chico. Its position is approximately shown on the map at the point marked +B. From the present position of this rock, weighing not less than 6000 pounds, to the mountains, is a distance of 200 miles, and it does not seem possible that this immense bowlder could have been transported that distance by any other agency than that of ice. I therefore conclude that, along with the elevation there were in the Cordilleras great accumulations of snow and ice, which produced glaciers extending out beyond the foot hills of the mountains even as far as the, at that time, eastern border of the sea. The glaciers no doubt transported most of the material now constituting the great bowlder formation from the Cordilleras to the sea, where it was afterwards distributed over the region to the eastward by the combined action of water and ice, either in the form of icebergs or floating shore and river ice. This would account for the enormously greater development of the bowlder formation near the Cordilleras than distant from them; for the gradually decreasing size of the rocks of which it is formed as we proceed eastward from the mountains, both of which facts have been observed and commented upon by Darwin; and also for the occasional occurrence in the formation of large bowlders in places far removed from the mountains, and which were doubtless carried by icebergs direct from the glaciers to their present positions.

Later Sedimentary Deposits.

In the region visited there are other sedimentary deposits, usually of very limited extent and evidently of quite recent origin. My observations do not warrant any very definite opinions regarding the origin or exact age of any of these deposits. Among them I may mention some of loess (?) in the

8.

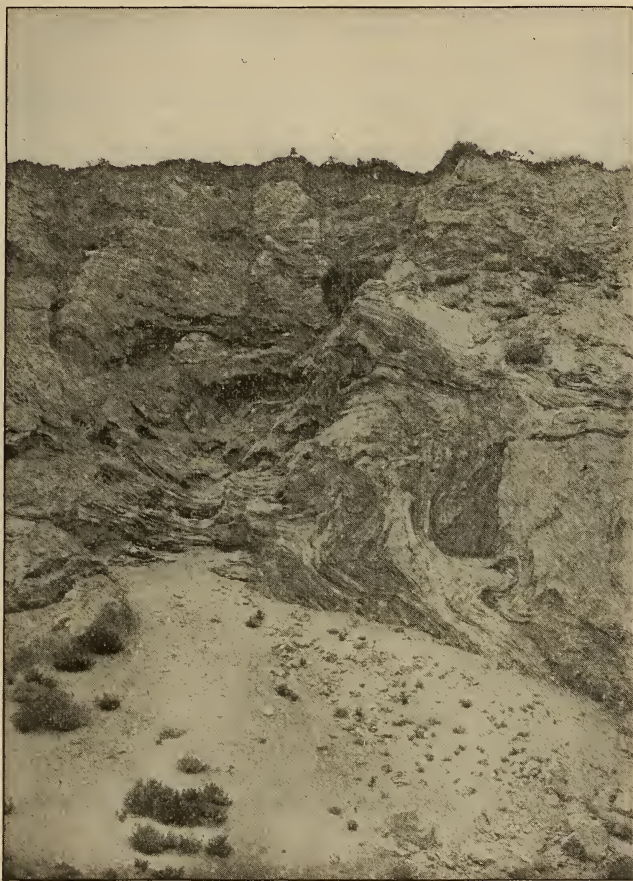

FIG. 8. Example of wind erosion on south fork of Rio Chico, Patagonia, from a photograph by the author.

high bluffs north of the Gallegos River, just west of Killik Aike. They rest unconformably upon the Santa Cruz beds, are about 40 feet thick and are composed of very fine sand

showing stratification toward the bottom, where we found the lignitized stems of small plants and parts of the skeletons of two rodents.

Important deposits of loess (?) were observed on the south fork of the Rio Chico, which may be really aqueous deposits belonging to the boulder formation. They are best exposed in the bluffs of the stream, where they show beautiful examples of wind erosion, a section of which is shown here in fig. 8.

Igneous Rocks.

Darwin, on ascending the Santa Cruz River, was very much struck by the beds of basalt which he observed capping the bluffs on either side of the stream at places remote from the Cordilleras, which he not unnaturally concluded had been the source of all the basalts of this region. He considered these basalts as examples of long distance lava flows over a bed only very slightly inclined. Had Darwin gone overland into the interior, instead of up the Santa Cruz River, he could not have failed to discover that the source of these lava beds was not the Cordilleras, but numerous small craters, found often in the immediate vicinity. There is a group of these craters only a few miles inland, near the mouth of the Gallegos River; they are most numerous over an area about forty miles in breadth, extending across the country from north to south, and distant about 80 to 120 miles from the mountains. It is sometimes possible to travel more than 100 miles between this chain of craters and the Cordilleras without passing over a single lava bed, especially in the district south of the Santa Cruz River.

Notwithstanding that these craters exist in such great numbers all over the plains of Patagonia and penetrate right through the strata of the Santa Cruz beds, yet there was nowhere observable, in their vicinity, any faulting or disturbance of the latter. I can only account for this on the theory, that these craters were in existence and active prior to and during the deposition of the Santa Cruz beds. I have no doubt that they were the source from which was derived much of the material of the latter deposits, since the latter are very largely composed of volcanic conglomerates and ash, as stated by Darwin.

It is also evident that many of these craters continued active long after the deposition of the Santa Cruz beds, for many of the lava flows may still be seen, in places, descending from the plains down over the slopes into the valleys of the water courses, showing that the latter had been eroded prior to the flow of streams exhibiting such conformation.

Many of the craters show, especially in their lower parts, a

well defined columnar structure ; while toward the top they are usually composed of great masses of vesicular slags and cinders with bright colors, jet black, steel blue, crimson and yellow predominating. One of these is shown in fig. 9. The columnar structure may be seen on the left near the base, while toward the summit only cinders and slags prevail. The two small "windows" on the left have suggested the name *Sierra Ventana*. It is on the right bank of the Rio Chico about 75 miles above the mouth of the Rio Chalia and rises to a height of perhaps 1200 feet.

9.

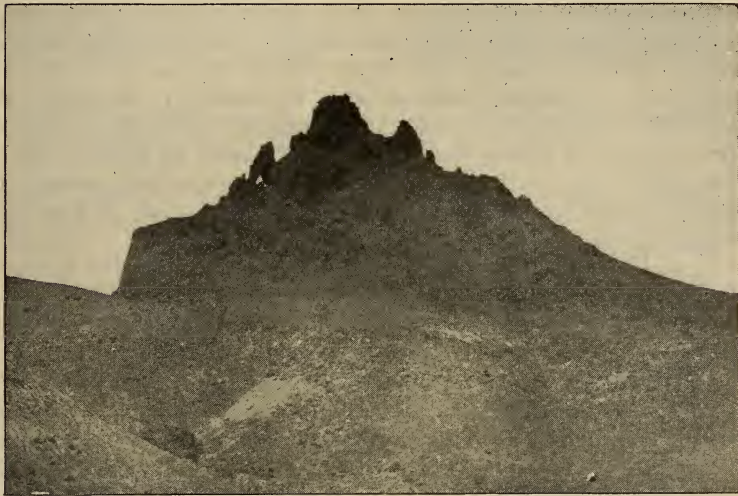

FIG. 9. Sierra Ventana, Rio Chico, Patagonia, from a photo. by the author.

The Transverse Valleys of Patagonia.

Dr. Florentino Ameghino, in his "Notes on the Geology and Paleontology of Argentina," after discussing at some length the boulder formation, takes up the origin of the transverse valleys of Patagonia. Since it appears to me that Dr. Ameghino is entirely wrong here, not only in his conclusions but also in his statement of facts, I quote him fully on this question. He says, on page 18: "Having now dispelled the ignorance as to the origin of the boulder formation, this leads us naturally to determine the age of the formation of the transverse valleys of Patagonia. It is evident that at the bottom of the ancient sea in which the boulders were deposited, these were scattered by the waters in a uniform manner over all the submerged territory. The same may be said of the sheets of

basalt; these also must have extended in a comparatively uniform manner, without forming the steep cliffs which they exhibit to-day in the river valleys. Darwin, speaking of the scarps of the valley of the river Santa Cruz, said that the cliffs of basalt of the two opposite sides were recognizable immediately as at one time forming a continuous bed. The same may be said of the beds of bowlders which in many parts form the opposite cliffs of the Patagonian valleys; those beds were continuous across the valleys, but there are now no traces of them.

"It is evident that if the valleys had existed before the great marine submergence referred to, they would have been completely filled with marine deposits, which, even supposing they had been swept away afterwards by the waters, would always have left numerous traces buried in the innumerable angles of the slopes; but as such deposits do not exist, the inevitable conclusion is, that the formation of the great transverse valleys of Patagonia was brought about by great dislocations and gigantic faults at a comparatively recent geological period, posterior to the bowlder formation and at the last emergence of the land."

If, as Dr. Ameghino states, "it is evident that at the bottom of the ancient sea in which the bowlders were deposited these were scattered by the waters in a uniform manner over all the submerged territory," is it consequently evident, as he concludes, that "if the valleys had existed before the great marine submergence referred to, they would have been completely filled with marine deposits," when these valleys are all many times deeper than the entire thickness of the bowlder formation? It certainly is not evident that these valleys would have been completely filled with marine deposits; but it is quite evident, that over their slopes and in their bottoms there would have been deposited a layer of bowlders, at least equaling in thickness that of the bowlder beds of the table lands. It is further evident, that supposing they had been afterwards swept away by the waters, they would have left numerous deposits buried in the innumerable angles of the slopes; and this is just what is to be seen in the sides of the cañons and larger water courses at almost every section shown along the coast or elsewhere. In fig. 6 are shown not only the bowlder formation but also the underlying Cape Fairweather beds, both occupying angles in the slope. In figs. 10 and 11 the remnants of the bowlder formation are shown occupying angles in the slopes of the cañons along this coast. At the points where both the latter sections are shown, it is quite possible to determine the relative amount of erosion which has taken place prior to and since the deposition of the bowlder formation.

Now, again, if, as Dr. Ameghino states: "The inevitable conclusion is, that the formation of the great transverse valleys of Patagonia was brought about by great dislocations and

10.

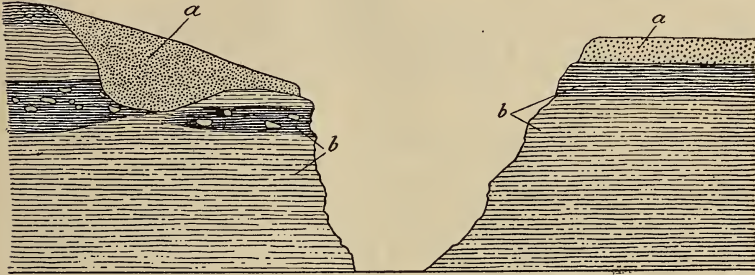

FIG. 10. Section as displayed in bluffs of coast at Corriken Aike about 18 miles south of Coy Inlet, showing the boulder formation occupying angles in the slope of the cañon. *a*. Boulder formation. *b*. Santa Cruz beds.

gigantic faults at a comparatively recent geological period, posterior to the boulder formation and at the last emergence of the land"; how could these beds of basalt and boulders now

11.

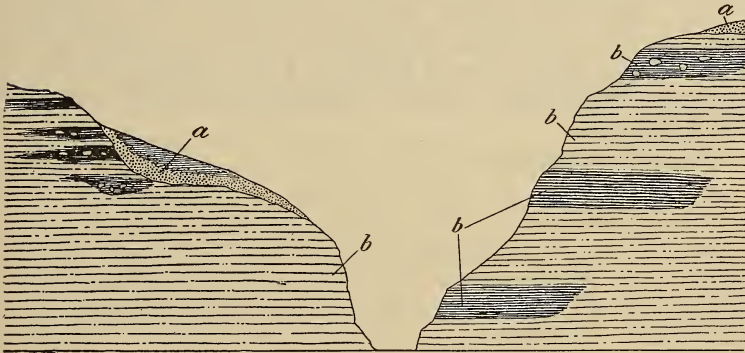

FIG. 11. Section as displayed in bluffs of sea coast at mouth of cañon about 10 miles south of Coy Inlet, showing boulder formation occupying angles in slope of cañon. *b*. Represents S. C. beds; *a*. Boulder formation covered by heterogeneous material of secondary deposition accumulated during the present period of erosion. The dark areas shown in both the above sections in the S. C. beds are composed of discontinuous strata of heavily bedded sandstones enclosing large concretions shown as white areas on the sketch.

form opposite cliffs of the valleys, as he has stated above? If there are such gigantic faults in this region, surely there should have been ere this some recorded observation concerning them. In so far as I know, no one has ever observed any dislocation

in these beds. My own impression was that the different strata on opposite sides of any given water course were remarkably similar and easily identified. Darwin also states, on page 119 of his "Geological Observations on South America," that the land in this region has been upraised without the strata having been in a single instance, as far as his observations went, unequally tilted or dislocated by a fault. I think it has now been pretty clearly shown that the transverse valleys of Patagonia are due to erosion, and that this erosion was partially accomplished before the deposition of the boulder formation. The lava beds, which now form opposite cliffs of the same valley, had their origin either during the deposition of the Santa Cruz beds or *immediately* after, and before any considerable erosion had taken place; while those showing conformation with an eroded surface—and there are many such—were ejected long after the close of the Santa Cruz period.

As an aid to others intending to visit this country for the purpose of collecting fossils, the following suggestions as to localities may be of some service. I have already indicated on the map the most promising localities for fossils in the Santa Cruz beds. I should especially recommend the bluffs on the north side of the Gallegos River from Guer Aike to a point opposite Gallegos; and the beach, below the bluffs, laid bare at low tide, on the coast between Corriken Aike and Coy Inlet. In the interior there are very promising localities in the bluffs of the Santa Cruz, Chalia and Chico rivers, and over a large area between the last two streams lying directly south of Sierra Ventana.

Princeton University, Sept. 26, 1897.

ART. XXXVIII.—On some of the large Oysters of Patagonia ;
by DR. ARNOLD E. ORTMANN. With Plate XI.

SINCE there is much confusion in regard to the identification of the giant oysters of Patagonia, it seems well to describe briefly those forms collected by Mr. Hatcher, and to give their proper geological relations.

1. *Ostrea hatcheri* nov. spec. (Plate XI, fig. 1.)

Shell almost circular in outline, very thick, lower valve concave, the upper valve less concave. Beak of upper valve only slightly projecting beyond that of the lower one. Area broadly triangular, much broader than long, a little more than $\frac{1}{3}$ as broad as the shell. Ligament groove comparatively shallow, about as broad as the lateral parts of the area. Anterior margin of muscular impression situated exactly in the middle of the inner surface of the shell (without area).

Measurements of the type: Length, 169^{mm}; breadth, 158^{mm}; thickness of lower valve, ca. 35^{mm}; breadth of area (lower valve), 54^{mm}; length of area, ca. 25^{mm}.

There is no doubt that this species has been seen by others, especially by Darwin, but it has been generally taken for *O. patagonica*. The chief differences between it and the latter are the following: 1. The outline of the shell is almost circular, in striking contrast to the subtriangular form of *O. patagonica*. 2. In *O. hatcheri* the area is comparatively broader and the beaks are not so produced as in *O. patagonica*, in which the area is only a little shorter than broad.

O. hatcheri, in its external form, comes very near to *O. maxima* Hup. (Philippi, Foss. Terc. Quart. Chile, 1887, Pl. 48, fig. 1), but it is at once distinguished by the situation of the muscular impression and the shape of the area, which is decidedly broader in *O. maxima*. Moericke (N. Jahrb. Min., etc., Beil. Bd. x, 1896, p. 575), in comparing *O. maxima* and *patagonica*, has already stated these differences. Since he refers to an *O. patagonica* from "Santa Cruz," it seems as if he mistook specimens of *O. hatcheri* for *patagonica*, and used them for comparison, and not d'Orbigny's figure of the latter. The outline of the true *patagonica* cannot be compared with that of *maxima*.

Localities: The type comes from the Patagonian beds of Santa Cruz (about 250 feet above high tide). Smaller and larger specimens have been found in the Supra-Patagonian beds of Upper Rio Chalia and Shell Gap. One from the latter locality measures: Length, 212^{mm}; breadth, 194^{mm}; thickness, ca. 50^{mm} (upper valve).

2. *Ostrea philippii* nov. nom. (Plate XI, fig. 2.)

Ostrea bourgeoisi Philippi, l. c., p. 207, pl. 48, fig. 3.

This species is characterized by its elongate-ovate form and its elongate-triangular area. It attains a considerable size and thickness (length, 236^{mm}; breadth, 130^{mm}; thickness, ca. 110^{mm}), and may have been also mistaken for *O. patagonica*. In our specimens the beak of the lower valve is longitudinally incurved, and in a few specimens this curve is very strongly pronounced.

I do not believe that this species is identical with the true *O. bourgeoisi* from the Californian Pliocene (Rémond, Proc. Calif. Ac., 1863, p. 13, and Gabb, Geol. Surv. Calif. Pal. ii, 1869, p. 33, pl. 11, fig. 57), since the most important character of the latter, the constriction of the shell near the cardinal area, is not represented in Philippi's figure, and is not exhibited by any of our specimens.

Localities: Very abundant in the Supra-Patagonian beds of Upper Rio Chalia and at Shell Gap on Upper Rio Chico. Philippi quotes it from Punta Arenas.

3. *Ostrea patagonica* d'Orb.

d'Orbigny, Voy. Amer. Merid. Pal., 1842, p. 133, pl. 7, fig. 14-16. Philippi l. c., p. 205, pl. 48, fig. 2.

This species differs from *O. philippii* by its subtriangular (not ovate) outline and the shortness of the beak and area.

O. patagonica seems to be restricted to the more recent beds of the South American Tertiary, since d'Orbigny's types are from Entre Rios, and most of the other localities given by him are situated in the northern parts of Argentina, where the older (Eocene or Miocene) beds seem to be absent. There has been much confusion as to this fossil, since almost all large oysters found in Patagonia have been called by this name. But in the true Patagonian beds and in the Supra-Patagonian beds *O. patagonica* is entirely wanting, *O. hatcheri* and *philippii* having taken its place.

There are numerous specimens of a large oyster in our collection from the probably Pliocene Cape Fairweather beds, which resemble very closely *O. patagonica*, but the muscular impression in all our specimens is situated nearer to the posterior margin of the valve than in d'Orbigny's figure. This Cape Fairweather oyster may be identical with *O. patagonica* or may represent, as Mr. Pilsbry believes, a new species; at any rate, it is closely allied to *O. patagonica*.

I present here a comparative plate giving the internal views of the lower valve of our types of *O. hatcheri* and *philippii*, as well as the reproduction of the original figures of *O. bourgeoisi* (pl. XI, fig. 3) combined from Gabb's fig. 57^a and 57^b (on pl. 7, l. c.), and a copy (pl. XI, fig. 4) of d'Orbigny's original figure of *O. patagonica* (l. c., pl. 7, fig. 14).

ART. XXXIX.—*The former Extension of the Appalachians across Mississippi, Louisiana, and Texas*; by JOHN C. BRANNER.

Introductory.

SEVERAL years ago I stated that *the old Appalachian land area crossed what is now the lower Mississippi Valley* from northern Alabama to the pre Cambrian area northwest of Austin, Texas.* I have not published the evidence that seems to support this theory, partly because the work I was doing in the State of Arkansas was constantly adding new facts to the information already in hand. The recent publication by Dr. Henry S. Williams of his paper on the Southern Devonian† induces me to give the results of my observations in connection with this subject in the hope that they may help toward the solution of the interesting problem he discusses, and toward the collection of data concerning the ancient physical geography of the southern states.

The Cretaceous embayment.

Orographic changes, probably dating about the close of the Jurassic, lowered a large area in Mississippi, Louisiana, Texas and southern Arkansas, admitting the sea across the former land as far north as southern Illinois. This embayment and its subsequent history are described by Hilgard,‡ and hardly call for detailed description or discussion here. Lower Cretaceous rocks in Arkansas, Indian Territory, Texas, Alabama and Mississippi rest unconformably upon the upturned edges of Coal Measures rocks. These Cretaceous beds cross Arkansas from southwest to northeast, and cross Alabama and Mississippi from southeast to northwest, and Tennessee from south to north. These facts are enough to show that this embayment took place at or about the beginning of Cretaceous time, and that it was caused by a depression in the region over which these sediments are spread. The present paper will deal principally with the extent of this depression.

Evidence, Character and Extent of the Southwestern Appalachian Depression.

The extent and character of the depression that admitted the Cretaceous sea across the Paleozoic rocks of Arkansas, Texas,

* Geol. Sur. of Arkansas, Ann. Rep. for 1890, vol. iii, 213; Proc. Bost. Soc. Nat. Hist., xxvi, 477.

† This Journal, May, 1897, pp. 393-403.

‡ Geol. History of the Gulf of Mexico, by E. W. Hilgard, this Journal, vol. cii, 391-404; Proc. A. A. A. S., xx, 222-236; Smithsonian Contributions, No. 248.

Louisiana, Mississippi and Tennessee are shown by a considerable number of facts, some of which, if taken alone, have but little weight, but pointing, as they do, all in the same direction, they make a reasonably strong case.

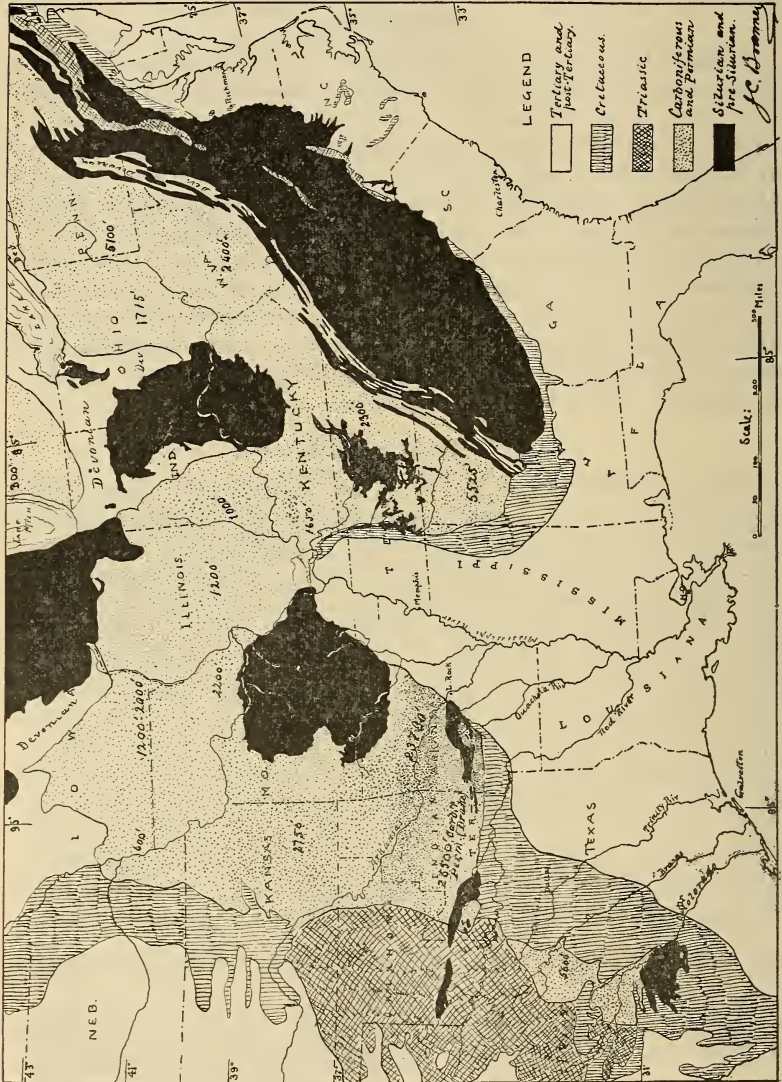

*The Reversal of the Arkansas drainage.**—In studying the origin of the lower Mississippi the possibility of the headwater

* See also Origin of the Lower Mississippi, by L. S. Griswold, Proc. Bost. Soc. Nat. Hist., xxvi, 474-479.

extension of some small south-flowing stream has been taken into consideration, but such an hypothesis claims little attention in this case. The lower Mississippi since Cretaceous times must be either the direct descendant of Carboniferous drainage, or else it has been produced by a depression in the lower Mississippi area which also caused a reversal of the Arkansas Valley drainage. Let us first consider the reasons for believing the drainage of the Arkansas reversed.

On any emerging coast the streams flow from the older toward the newer beds. Along the Atlantic slope the streams flow from the Paleozoic uplands across Triassic, Cretaceous, Tertiary, Pleistocene and recent deposits into an ocean where sediments are actually being laid down. In the same way the emerging Carboniferous lands must have had their drainage flowing from new Carboniferous beds into Permian seas, and later, as emergence proceeded, these streams must have flowed across Permian sediments into Triassic waters, and so on, as long as the orographic movements were even. Now in Arkansas the succession of the beds, in the order of their deposition from the Carboniferous upwards, is found by going westward up the Arkansas and Canadian rivers into Indian Territory and Oklahoma. Along such a section one passes from the Lower to the Upper Coal Measures, thence to the Permian, Triassic, Cretaceous, and Tertiary in their order; and this must have been the direction of the drainage while these beds were being deposited. That is, the sea that occasionally invaded this region receded westward and was gradually crowded in between the Ozarks and the Rocky Mountains. Further, the area between the Ozarks and the Ouachita uplift is structurally a great synclinal trough dipping westward. These structural features must have determined the direction of the drainage during Carboniferous and later times. The Arkansas river therefore flows, not with the dip of the rocks, as it did originally, but against it. Such a state of affairs would be brought about by the lowering of the Mississippi River region. The amount of depression necessary to reverse the drainage is given on p. 360, under the head of the "Slope of the Ouachita uplift."

Although Cretaceous and Tertiary beds fill the Mississippi embayment, there are neither Permian, Triassic nor Jurassic rocks exposed anywhere beneath them or along their edges. Whatever may have happened in the lower Mississippi area, it is therefore reasonable to suppose that the drainage flowed westward through the Arkansas Valley during Carboniferous, Triassic and Jurassic times, and entered the Mediterranean sea that lay along the eastern base of the Rocky Mountains. And the reason for this westward Carboniferous and later drainage

was probably the barrier made by the Ouachita anticline and its eastward and westward extension.

Reversed Carboniferous drainage in Texas.—In Texas there has been a similar reversal of the drainage over the Carboniferous area. Even now, and in spite of an eastward tilting of the region, the Carboniferous rocks of Central Texas dip gently westward while the Colorado, Brazos and Red rivers flow southeast or eastward against the dip. Dr. N. F. Drake, who studied the area, believes, from internal evidence, that the sediment came from the east.* They are said by Professor Hill to have been covered by Cretaceous rocks;† in this case the present southeast drainage across the Carboniferous has been superimposed, but in any event it has been reversed. Additional evidence of the southeastward origin of the Carboniferous sediments of central Texas is given under the head of "Carboniferous sediments."

The submerged end of the Ouachita uplift.—A geologic map of the State of Arkansas shows the Ouachita anticline to have an east-west axis and a core of Lower Silurian rocks (though some of them may be older). The western end of this anticline tapers to a point in the western part of the state, and the Lower Coal Measures rocks swing round and dip away from it on all sides. It is reasonable to suppose that its eastern end had a more or less similar form, but it is now concealed by Cretaceous and Tertiary rocks that lap over and across it in such a manner as to give it the appearance of having been cut almost square across—an appearance that could have been produced only by the lowering of this eastern end beneath the Cretaceous and Tertiary seas, and the deposition of their sediments upon it. (See accompanying plate showing the Ouachita anticline.)

Slope of the Ouachita uplift.—The slope of the Ouachita uplift is toward the east. This is true both of the general surface and of the higher elevations over the entire area. The general level of the highest of the Silurian peaks about the eastern end of the Ouachita anticline is between 500 and 600 feet above sea level, while the general elevation of the same novaculite rocks about Hot Springs is about 1200 feet, and south of Dallas, Arkansas, at the western end of the anticline, about 1900 feet. The greatest elevations in the western part of the state, however, are in Lower Coal Measures rocks: the highest of these are between 2750 and 2825 feet; Shinall Mountain, the highest mountain of Carboniferous rocks at the eastern end of the Carboniferous area, is 1050 feet high, while most of the high points about this eastern end are between

* Fourth Ann. Rep. Geol. Survey of Texas, 1892, p. 373.

† Bull. Geol. Soc. Amer., ii, 527.

500 and 750 feet above sea level. If we take the lowlands we have an elevation of 500 feet about Fort Smith, and of 250 to 300 feet about Little Rock. The fall of the Arkansas river from Fort Smith to Little Rock, a distance of 140 miles on a line, is about 200 feet. A reversal of the drainage of the main stream from Little Rock to Fort Smith only with the same slope, would require an elevation of 400 feet at Little Rock. Or the reversal of the drainage from the Mississippi river to the Permian border, 100 miles west of Fort Smith, would require an elevation of 925 feet at the Mississippi river. And it is interesting to note that if the Mississippi region about Memphis and Helena were brought up to a level with the base of the Permian in Indian Territory it would be about on a level with the Carboniferous of southern Illinois, Indiana, western Kentucky, Tennessee and Alabama. This does not take into account the removal of Carboniferous rocks by erosion.

Drainage of the Ouachita uplift.—An examination of the accompanying map shows that the drainage of the Ouachita mountain region is now only partially controlled by the structure, and, as the tendency is for the structure to control it more and more, it is fair to assume that not long ago it was less influenced by the structure than it is at present. The present elevation of some of the Tertiary beds near the Silurian area lead me to believe that during Tertiary times nearly all the lower portion of the Ouachita uplift region was covered by water and sediments. This would account for the drainage, but inasmuch as there is a general southeastern direction to the streams (the Ouachita, the Saline, and the Caddo), the slope of the Tertiary surface as it emerged must have been toward the southeast—in the direction of the principal axis of disturbance. This will be the more apparent if it be remembered that the Silurian rocks across which the several forks of the Saline, the Ouachita and the Caddo flow, are largely novaculites—extremely hard and resisting rocks which stand out in high, almost perpendicular ridges.

Faults in Arkansas and Indian Territory.—The faults and folds across the eastern end of the Boston Mountains and close to the depressed area are approximately parallel to the Cretaceous and Tertiary margin. This margin has a direction of North 30° to 35° East. The folds through the Arkansas valley are approximately east-west, but about the eastern end of the Boston mountains they swing away toward the north, where they bear North 50° East.*

It was hoped that the faults in the State of Arkansas might throw much light upon the subsidence under consideration.

* Newsom and Branner, *Amer. Geol.*, July, 1897, xx, pp. 1-13.

Thus far, however, the facts gathered regarding them are not sufficient in number, or they are not as yet well enough understood, to lead to any decided conclusions. In the northern part of the state, in the Boston Mountains region, the faults are nearly all normal or tension faults, while south of the Arkansas river and in the Ouachita region they are reversed faults. The one that lies nearest the Cretaceous border is the Red River monoclinical fold which merges into a fault about its northern end in the vicinity of Batesville. Here the downthrow is on the southeast side and the displacement is 165 feet;* at one place it is more than 200 feet. In Stone county a fault on Roasting-ear Creek has its downthrow of 100 feet on the south; in Baxter county on Spring Creek is a downthrow of between 200 and 300 feet on the south; on Rush Creek, Marion county, the downthrow is 260 feet on the south side; a fault about twelve miles long runs northeast from near St. Joe having a downthrow of about 200 feet on the south side. The St. Joe fault has its downthrow of 283 feet on the south. On Big Buffalo Creek (16 N., 22 W., secs. 10-11) the downthrow on the south is 400 feet. Many other similar cases might be cited. It should be added, however, that there are several faults in this same region having the downthrow on the north side; and there are some cases of long narrow strips having sunk downward. The faults here mentioned are north of the Boston mountains. South of the mountains we have the Red River monocline turning westward and passing into a great fault along the south face of the Boston mountains with a downthrow of several hundred—perhaps a thousand—feet on the south.

On the south side of the Arkansas Valley faults are known with the downthrow on the north, but on this side of the valley the faults are, in every case with which I am acquainted, reversed faults. Three miles up the river from Little Rock, at Big Eddy, are evidences of a reversed fault having the north side underthrust.

In the novaculite area through the Ouachita region but few faults have been located with certainty; the one mentioned by Mr. Griswold in his report on novaculites has no reference to the direction of the downthrow,† but the field-notes show that it is on the south side. The novaculite region as a whole has the beds pretty closely squeezed, and it is quite probable that instead of a few large faults it has a great many small ones.

Dr. N. F. Drake, who has lately studied the geology of the Indian Territory, tells me that the rule for Arkansas faults

* Ann. Rep. Geol. Sur. Arkansas, 1890, vol. i, 111, 220.

† Ann. Rep. Geol. Sur. Arkansas, 1890, iii, 295.

holds in the Territory, namely, that the faults about the Ozarks are normal, while in the region south of the Canadian river they are reversed.

Faults in Texas.—I know of no considerable faults in the Cretaceous rocks of Arkansas, but in Texas there is a remarkable one. As a prominent break it begins about eight miles north of Austin and passes southward through the western edge of the city of Austin, through San Marcos, New Braunfels and San Antonio, and thence westward toward the Rio Grande. West and north of this fault rises an escarpment capped by Lower Cretaceous rocks, while on its east and south side the beds forming the top of the downthrow are Upper Cretaceous. This downthrow is from a thousand to fifteen hundred feet and is on the south side.* The nature of the contact between the upthrow and the downthrow often shows that the fault is not a single slip but several faults close together. The direction of this great Texas fault agrees closely with the western margin of the Cretaceous-Tertiary border through Arkansas. It is supposed to be of Tertiary or later age.†

The effect of such a depression upon the physiography of the lower Mississippi will be realized when we remember that such a movement (1500') at the present time would submerge the greater part of the Appalachian mountains.

This fault shows, moreover, that there has been more than one epoch of disturbance and depression in the region under discussion. The embayment began in early Cretaceous times, but this fault is post-Cretaceous.

Faults in Alabama.—In the Cahaba coal fields of Alabama the faults are parallel with the Appalachian axis and the downthrow is on the northwest—the embayment side.‡ Inasmuch as the Coal Measures rocks abut against Silurian and Cambrian beds on the southeast, the total displacement cannot be determined. From the bottom of the Carboniferous on the northwest side to the surface on the southeast side is a distance of 5500 to 5600 feet, but this makes no allowance for erosion from the uplifted surface, which must be somewhat greater than the thickness of the Carboniferous beds. McCalley says that the throw of some of these faults is 10,000 feet or more.§ Sections across Blount Mountain, Alabama, coal field show the basin tipped toward the northwest.¶ In the Coosa coal field

* Communicated by N. F. Drake.

† R. S. Tarr, Proc. Acad. Nat. Sci. Phil., 1893, p. 319. Professor Hill shows six faults on the Colorado river northeast of Austin. Amer. Geol., May, 1889, p. 7.

‡ Map of the Cahaba Coal Field, by Squire and McCalley, 1896.

§ Coal Measures of the Plateau Region of Alabama, 1891, p. 218.

¶ A. M. Gibson, Report on Blount Mountain, 1893, map.

the faulting is said to be "not less than 8000, probably 10,000 feet," and "the base of the adjacent Coal Measures must be at least 4000 feet below sea level!"* Gen. Gibson also notes that the throw of the Alabama faults is greater toward the south. If the theory of the continuity of this old land area into Texas is correct, the ridge must have bent westward in western Alabama.

Eruptives in Arkansas and Texas.—The distribution of the eruptive rocks of Arkansas and Texas follow close and parallel to the old Cretaceous-Tertiary shore line. The syenites near Little Rock and those of Saline county, Arkansas, are both just within the present Tertiary border, while the Magnet Cove eruptives in Hot Spring county are but two miles northwest of it. The age of these eruptives has never been definitely settled. In Pike county there is a dike of peridotite in Lower Cretaceous rock. The bauxites near Little Rock are interbedded with Tertiary sediments, and, believing, as I do, that the bauxites were formed at the time of the extrusion of the syenites I conclude that the syenites are of Tertiary age. In any case they lie near the old Tertiary shore line, and appear to offer corroborative evidence of faulting or other weakness along this line.

At Austin, Texas, are many eruptives of Upper Cretaceous age; † in Uvalde county, Texas, eruptives penetrate Lower Cretaceous rocks; ‡ in Rockwall county east of Dallas is an isolated area of Tertiary igneous rocks. Hill and Dumble have pointed out the fact that there is a line of eruptives of post-Eocene age at no less than fifty places from east of Austin to the Rio Grande, and speak of them as being "along a line of weakness in the earth's crust which has apparently existed in this region." § These facts suggest that the line of weakness referred to by Messrs. Hill and Dumble has been manifesting itself since Jurassic times and that its influence reached into Tertiary times.

Hot Springs.—The hot springs of Arkansas are a little northwest of the Tertiary border, and may be regarded, like the eruptives, as having some possible connection with the line of disturbance that extends across the state. Professor Hill mentions evidences of hot springs along the line of the great fault in southwest Texas.

Thickness of the Cretaceous and Tertiary sediments.—If the lapping of the Cretaceous and Tertiary sediments across the Coal Measures of eastern Arkansas and Louisiana was

* A. M. Gibson, Rep. upon the Coosa Coal Field, p. 86.

† R. T. Hill, Amer. Geol., 1890, vi, 291.

‡ A. Ossan, Jour. Geol., i, 341.

§ Proc. A. A. A. S., vol. xxxviii, 242, 243; this Journal, vol. cxxxvii, p. 288.

caused by a depression, the thickness of these sediments should afford some clew to the amount of that depression. The thickness of the Cretaceous beds in Arkansas is estimated at 3520 feet.* In Texas, near Austin, the Colorado river exposes 5210 feet of rock overlying the Paleozoic, while further south, the Comanche alone is said to be nearly 5000 feet thick.† The dip of the Tertiary beds of Arkansas suggests a possible thickness of more than 3000 feet of Eocene alone in that state.‡

A bore hole put down on Orange Island, Louisiana, 130 miles due west of New Orleans, penetrated 2100 feet of salt and other sediments.§ The age of these salt beds is not known;|| they may be either Cretaceous or Tertiary—more likely the former.

At Galveston, Texas, a deep well penetrates 3070 feet of sediments *without reaching the Eocene*.¶ These facts point to 3500 feet of Cretaceous, 3000 feet of Eocene and more than 3000 feet of sediments above the Eocene, in all over 9500 feet.

In western Alabama the Cretaceous beds are 2575 feet thick, while the Tertiary and post-Tertiary are 3120 feet—a total of 5705 feet deposited in that region since the Appalachian subsidence.**

Although more or less disconnected, these facts strongly suggest a total thickness of Cretaceous and post-Cretaceous sediments of somewhere between 5000 and 10,000 feet in that part of the embayment which the old Appalachian land is believed to have crossed. Such a depression would submerge the entire Appalachian system of to-day.

It cannot be positively stated, however, that this thickness extends over the entire lower Mississippi area, or even that it occurs at any one place. Indeed it is well known that there are Cretaceous outliers in Louisiana without any Tertiary beds on top of them.††

The "sunk lands."—The ancient earthquakes in northeast Arkansas and southeast Missouri were in the upper portion of this embayment. It is well known that at the time of these earthquakes large tracts of land sank and produced lakes, and

* R. T. Hill, Geol. Surv. Ark., Ann. Rep., 1888, ii, 188.

† R. T. Hill, Amer. Geol., May, 1889, iii, 289; this Journal, vol. cxxxiv, 301.

‡ Geol. Surv. Ark., Ann. Rep., 1892, ii, 186.

§ A. F. Lucas, Eng. and Mining Jour., Nov. 14, 1896, 464.

|| Geology of Lower Louisiana and the salt deposit on Petite Anse Island, by E. W. Hilgard, Smithsonian Contributions to Knowledge, No. 248, Washington, 1872.

¶ Dumble and Harris, this Journal, July, 1893, vol. cxlvi, 39-42.

** E. A. Smith, The Coastal Plain of Alabama, p. 27. In the same volume Dr. Langdon gives a general section of 4215 feet, and the columnar sections (pl. 28, p. 728) give a maximum of 4175 feet of Cretaceous and Tertiary.

†† E. W. Hilgard, this Journal, vol. cii, p. 395; Smithsonian Contributions No. 248, p. 27; Mineral Resources of the U. S. (1883), p. 557.

it is stated that the cracks in the earth ran northeast-southwest.* These disturbances were local, but occurring in a region which must necessarily have been more or less disturbed since Carboniferous times, they may safely be regarded as corroborative evidence.†

Submerged pre-Cambrian.—The Appalachian mountains, where they plunge southwestward beneath the Cretaceous sediments in central Alabama, are composed of Silurian, Cambrian and pre-Cambrian rocks (schists and granites), with Carboniferous beds lying against their northern side. In the area northwest of Austin, supposed to be the southwest terminus of these Appalachian beds, the rocks are Silurian, Cambrian and pre-Cambrian (schists and granites) with the Carboniferous sediments resting against their north side. These Texas beds plunge eastward beneath Cretaceous rocks. It is worthy of especial note that this Texas area was submerged during Cretaceous times,* and that it was formerly buried beneath Cretaceous sediments which have been removed by erosion. From this pre-Cambrian area the Cretaceous beds now extend away to the east, and it seems altogether probable that these beds conceal the eastward continuation of the older rocks. Naturally also the overlying rocks are thicker toward the east owing to the greater depression in that direction. Thus the rocks of the southwest end of the present Appalachians seem to be identical with those of the pre-Cambrian area of Texas, and to bear the same structural relations to the Carboniferous rocks on the one hand and to those of the Mississippi embayment on the other.

The structural relations of the Ouachita uplift.—I was at first disposed to think the Ouachita uplift a part of the old Appalachian land system, but this opinion I have been obliged to abandon. The theory here put forward and the facts that appear to support it throw much light on the structural and physiographic relations of the Ouachita anticline in Paleozoic times. Had this Ouachita anticline been an isolated one like the Ozark island, then the southward Carboniferous drainage would have flowed east of it very like the drainage of the present time. If it had been a part or end of the Appalachian system, the Carboniferous drainage would have flowed westward through the Arkansas valley, but we should be at a loss for an explanation of the phenomena of the Carboniferous area of central Texas, and also for the absence from the Ouachita region of the Cambrian and pre-Cambrian rocks so

* This Journal, vol. xv, 1829, p. 36.

† A second visit to the United States, by Sir Charles Lyell, N. Y., 1849, vol. ii, pp. 172-181; Bringier in this Journal, 1821, iii, 20-22; Flint in *ibid.*, 1829, xv, 366-368.

‡ R. T. Hill, Bull. Geol. Soc. Am., ii, 527; this Journal, vol. cxxvii, 283.

characteristic of Appalachian geology. But if the Ouachita uplift is the structural equivalent of the Cincinnati-Nashville anticline, then it was a region of shallow water at least, and during the land periods turned the drainage from the Indiana-Illinois basin westward through the Arkansas valley. This major anticlinal axis extended westward through the Arbuckle mountains of Indian Territory and ended with the Wichita mountains in southern Oklahoma Territory. The Appalachian system crossed the present Mississippi valley further south, and there was another broad syncline between that watershed and the Ouachita region, and the drainage flowed westward through this valley across south Arkansas, Louisiana and northern Texas, and entered the Carboniferous sea south of the Arkansas valley discharge.

That this last is the correct theory is borne out by the facts that follow :

Southern origin of the Ouachita sediments.—The Paleozoic sediments on the south side of the Ouachita uplift are coarser than the materials of the same beds on the north side. This peculiarity is noticeable even in the Silurian novaculites : those on the south “are pure in composition and massive, while on the north side they have largely the character of siliceous shales.”* Again, the beds overlying the novaculites on the south are sandstones, while on the north they are shales. These facts seem to place the Ouachita uplift, in its relations to the source of its sediments, in a position analogous to that of the Cincinnati and Nashville arch whose sediments are supposed to have been derived from the Appalachian lands.

The Carboniferous sediments.—The accompanying map shows the varying thickness of the Carboniferous rocks. It is noticeable that the greatest thickness is in the Arkansas-Indian Territory valley, in central Texas, in western Pennsylvania, and in northwestern Alabama. Attention should be directed to the fact that only the upper part of the Texas Carboniferous beds is uncovered. On the Brazos River, southwest of Weatherford, *Fusilina* limestone is exposed, showing these beds to belong to the Upper Coal Measures. But these rocks are not the highest, but the lowest, exposed in the central part of the Texas Carboniferous area.† The Texas coal is therefore higher up than is the coal of Indian Territory and Arkansas. This shows that coal-forming conditions prevailed in Texas later than in Indian Territory and Arkansas. It cannot be said that the Arkansas basin shallowed earlier than that of Texas, for the Texas beds of equal age with the lowest coal of Arkansas are concealed by Cretaceous rocks.

* L. S. Griswold, Geol. Sur. Ark. Ann. Rep., 1890, iii, 193.

† Communicated by N. F. Drake.

These facts are all in keeping with the theory put forward. It is to be expected that the sediments would be thicker near the supplying land area, such as existed along the Appalachian highlands, and where the drainage became sluggish near the waters into which it is discharged, that is, in Texas, west Arkansas, and Indian Territory. And unless it be admitted that there was a land area across eastern Texas, Louisiana, and Mississippi, we are at a loss to explain the source of supply for the 5600 feet of upper Carboniferous sediments* in central Texas. In the Arkansas valley, where these sediments have been shown to have a thickness of 23,780 feet,† and in Indian Territory, where the Coal Measures are 25,000 feet thick, or with the Permian 26,500 feet (N. F. Drake), the supply of the coarser materials could hardly have come from elsewhere than the Ozark mountains in Missouri.

The central Texas coal area and the Indian Territory-Arkansas basin seem to represent the ends or mouths of synclinal valleys in which conditions favored the deposition of enormous beds of sandstones and shales. In the neck of Upper Coal Measures rocks near San Saba, Texas, where they almost abut against the pre-Silurian area, these beds strike about N. 35° E. This suggests a southeast origin for these sediments. In Arkansas and Indian Territory the upper beds strike across the trough of the valley in this fashion, while the lower ones are more nearly parallel with its sides. In the same way it is to be supposed that the earlier Coal Measures beds of the Texas trough swing round and strike east-west.

Marine Coal Measures fossils.—South of the Ouachita uplift the Coal Measures beds have yielded comparatively few fossils, and most of these are coal plants. A few crinoid stems and bryozoa, however, have been found near Antoine in Pike county (8 South, 23 West, sec. 24), enough to show that the conditions on the south side of the fold were very or quite like those on the north side. These conditions were: a low-lying region occasionally invaded by the sea. This idea is also borne out by the nature of the Carboniferous beds of central Texas, where limestones are interbedded with the usual sandstones and shales.‡

The Arkansas valley syncline sank occasionally during Coal Measures times so as to admit the sea across the region: this is shown by the marine fossils found in the rocks there.§ This

* R. S. Tarr (Amer. Geol., 1892, ix, 169) gives 8000 feet as the thickness of these rocks. Later work by N. F. Drake shows that earlier estimates are a little too high, probably because the dip is not so steep along the western edge of the Carboniferous. Fourth Ann. Rep. Geol. Surv. Texas, 355-446.

† This Journal, 1896, vol. clii, p. 235.

‡ N. F. Drake, Rep. on the Colorado Coal Field of Texas, Fourth Ann. Rep. Geol. Surv. Tex., 355-446.

§ J. P. Smith, Proc. Am. Phil. Soc., vol. xxxv, No. 152.

sea lay along the eastern base of the Rocky Mountains, for while marine Coal Measures fossils are not common in the eastern part of the Coal Measures area, in Illinois and Arkansas they are much more plentiful, and in rocks of the same age along the foot of the Rocky Mountains they are still more abundant.

Résumé.

I. The Ouachita anticline is the structural equivalent of the Cincinnati-Nashville arch; this fold continues westward through the Arbuckle mountains in Indian Territory and to the Wichita mountains in southern Oklahoma Territory.

II. The Coal Measures drainage of the Illinois-Indiana-Kentucky basin flowed westward through the Arkansas valley into a Carboniferous mediterranean sea.

III. The drainage of the Coal Measures region south of the Ouachita anticline flowed westward and entered this sea north of the Texas pre-Cambrian area.

IV. The drainage of both the Arkansas and Texas Carboniferous areas was reversed about the end of Jurassic times, when orographic movements over southeast Arkansas, eastern Texas, Louisiana, and Mississippi submerged the former extension of the Appalachian watershed and admitted the early Cretaceous sea across the Paleozoic land as far north as southern Illinois.

V. This depression was not a deep one (Hilgard)* and did not all occur at one time, for there have been subsequent disturbances of a more or less similar nature in the same region.

VI. The evidences of these depressions are :

1. The reversed drainage of the Arkansas valley.
2. The reversed drainage over the Carboniferous area of central Texas.
3. The submerged eastern end of the Ouachita uplift.
4. The eastward slope of the peneplain of the Ouachita region.
5. The direction of the faults and folds near the eastern exposure of the Lower Coal Measures in Arkansas.
6. The great fault through Texas near the Tertiary border, having a downthrow of 1000 to 1500 feet on the south and east sides.
7. Eruptive rocks accompanying the Texas fault and the Tertiary border through that state and Arkansas to the Arkansas river.
8. Hot springs near the same line.
9. Faults in Alabama with a downthrow of 10,000 feet or more on the northwest side.
10. The thickness of the Cretaceous and Tertiary sediments over the depressed area: from 4,000 to 10,000 feet.

* This Journal, 1871, vol. cii, p. 394.

VII. The southwestern or central Texas end of the Appalachian land area was formerly covered by Cretaceous sediments, but it has since been uncovered by erosion; further east it is still concealed.

VIII. The Carboniferous beds uncovered in Texas all belong to the Upper Coal Measures; it is inferred that a greater thickness is still covered.

IX. The character of both the Silurian and Lower Coal Measures sediments of the Ouachita uplift show that they came from the south, so that the land area must have been in that direction during Paleozoic times.

X. The sea occasionally invaded both the Arkansas and Texas synclinal troughs during Coal Measures times, but coal-forming conditions obtained in the Texas syncline later than in the Arkansas basin.

XI. The Tertiary depression was probably more marked on the Arkansas than on the Tennessee side of the embayment; this is shown by the Cretaceous border being concealed by the Tertiary deposits in Arkansas, while in Tennessee, Mississippi and Alabama they are exposed in a broad belt.

ART. XL. — *The Combustion of Organic Substances in the Wet Way*; by I. K. PHELPS.

[Contributions from the Kent Chemical Laboratory of Yale University—LXVI.]

IN a former paper* I have shown that carbon dioxide may be estimated iodometrically with a fair degree of accuracy. Inasmuch as this method is not dependent upon the rate of flow or rapidity of generation of the carbon dioxide, it seemed possible that some advantage might follow its application to the determination of organic carbon, oxidized by liquid reagents.

Method of oxidation by Potassium Permanganate.

The first experimental test in this direction was made with oxalic acid, which was oxidized according to the well-known reaction of potassium permanganate in the presence of sulphuric acid. The apparatus used was the same as that previously described in the iodometric process, referred to above. It consisted, in the main, of an evolution flask and an absorption flask, properly connected. As an evolution flask, a wide-mouthed flask of about 75^{cm} capacity was used. This was closed by a doubly perforated rubber stopper, carrying a separating funnel for the introduction of liquid into the flask and a glass tube of 7^{cm} internal diameter, which was expanded to a small bulb just above the stopper, to carry off the gas. This exit tube was joined by means of a rubber connector to a tube which passed through the rubber stopper of the absorption flask, which was an ordinary round-bottom flask of 250^{cm} capacity. This tube ended in a valve of the Kreider pattern,† which was enclosed in a larger tube, reaching nearly to the bottom of the absorption flask. The second hole of the stopper of this absorption flask, was filled by a glass tube closed by a rubber connector and screw pinch cock.

The barium hydroxide solution for use in the determination of the carbon dioxide was prepared by filtering a cold saturated solution of the commercial salt into a large bottle, which was connected with a self-feeding burette. The solution was standardized in the manner described in my former paper by boiling with an excess of decinormal iodine solution in an ether wash bottle. The short tube of the glass ground stopper of the bottle was sealed to a Will and Varrentrapp absorption apparatus, which was charged during the operation with a solution of potassium iodide to prevent the loss of elementary

* This Journal, vol. ii, p. 70.

† This Journal, 1, p. 132.

iodine in the boiling; the long tube of the bottle was used as an inlet tube and was closed externally by a rubber cap during the boiling. After cooling, the excess of iodine used was determined by titration with decinormal arsenious acid solution and the iodine lost calculated on barium hydroxide molecule for molecule.

Potassium permanganate was prepared for use by dissolving the commercial salt in water, and boiling this solution, made acid with sulphuric acid, until free from carbon dioxide. Water was also prepared free from carbon dioxide by boiling distilled water until one-third had been driven off in steam and was kept until used in full-stoppered flasks.

For the first determinations of carbon, crystallized ammonium oxalate was weighed out and introduced into the boiling flask with 10–15^{cm³} of pure water and the flasks connected as described above with an appropriate amount of barium hydroxide solution (3–5^{cm³} in excess of the amount required to precipitate the carbon dioxide to be determined) in the absorption flask. The whole system was then evacuated with the water pump to a pressure of 200–225^{mm} and the oxalate solution in the boiling flask warmed. An excess of potassium permanganate solution was then run in through the funnel tube and the mixture warmed again, when the oxidation of the oxalate was shown by the carbon dioxide evolved. The carbon dioxide was completely set free by the introduction of 10^{cm³} of sulphuric acid (1:4) and was driven completely to the absorption flask by boiling for five minutes. During the passage of the gas into the absorption flask, it was shaken frequently and was kept cool by standing in a dish of water and by pouring cold water over it from time to time. If, during the boiling, any fears are entertained as to the strength of the vacuum in the flasks, they may be easily allayed by opening momentarily the stop cock of the funnel tube and noting the direction of the flow of water, contained in the funnel. After the boiling was ended, the atmospheric pressure was restored by allowing air, purified from carbon dioxide by passage through potash bulbs, to enter through the funnel tube of the boiling flask. Then the flasks were disconnected and the stopper of the absorption flask with its attachments was removed, the valve and its tube being carefully washed free from barium hydroxide. A second stopper, which was provided with a separating funnel, and a Will and Varrentrapp absorption apparatus, containing water to serve as a trap, was inserted into the mouth of the absorption flask and the emulsion brought to the boiling point. Decinormal iodine solution was then run in through the funnel tube in sufficient quantity to destroy the larger part of the excess of barium hydroxide and the emulsion brought to the

boiling point again, after which iodine was again run in but this time to the permanent red color of the excess of free iodine. After cooling, this excess of iodine was determined by titration with decinormal arsenious acid solution. Thus, the excess of barium hydroxide used being determined by the iodine lost, the barium hydroxide used, now in the form of carbonate, was known, from which the carbon dioxide which precipitated this carbonate, may be calculated.

The following results were obtained by this procedure.

TABLE I.

| Ammonium oxalate taken. grm. | BaO ₂ H ₂ taken. grm. | BaO ₂ H ₂ found. grm. | CO ₂ found. grm. | CO ₂ calculated. grm. | Error on CO ₂ . grm. |
|------------------------------|---|---|-----------------------------|----------------------------------|---------------------------------|
| 1. 0.2522 | 0.7267 | 0.1170 | 0.1565 | 0.1561 | 0.0004 + |
| 2. 0.2542 | 0.7267 | 0.1113 | 0.1579 | 0.1574 | 0.0005 + |
| 3. 0.5020 | 1.4535 | 0.2417 | 0.3110 | 0.3108 | 0.0002 + |
| 4. 0.5058 | 1.3954 | 0.1753 | 0.3131 | 0.3131 | 0.0000 ± |
| 5. 1.0033 | 2.6163 | 0.1955 | 0.6213 | 0.6211 | 0.0002 + |
| 6. 1.0003 | 2.5951 | 0.1836 | 0.6189 | 0.6192 | 0.0003 — |
| 7. 1.0010 | 2.6163 | 0.2037 | 0.6192 | 0.6197 | 0.0005 — |

In experiments (5) and (6), a few drops of ammonia were added to the oxalate solution before running in the permanganate; in (3) and (7), the permanganate was treated to alkalinity with barium hydroxide; in the remaining experiments, (1), (2) and (4), the permanganate was slightly acid with the sulphuric acid used in its purification from carbon dioxide, as already described. The results obtained are good and it is plain that the oxidation proceeded regularly, whether the first action of the permanganate was in the alkaline or slightly acid solution.

Jones* has shown that formates may be determined volumetrically by titration with potassium permanganate in alkaline solution. In an attempt to determine formates by the process outlined above, the pure barium salt was used. This was prepared by treating the aqueous solution of formic acid with pure barium carbonate to neutrality and crystallizing the product. It was proven pure by ignition and weighing in the form of carbonate.

In making determinations of carbon in this formate, weighed portions were introduced into the boiling flask, together with sodium hydroxide solution, which was taken in such quantity as to more than neutralize the acid in the potassium permanganate. Naturally, the sodium hydroxide must be free from

* Amer. Chem. Jour., xvii, 539.

carbonate—which was effected by treatment with an excess of barium hydroxide and filtering. An excess of potassium permanganate is then run into the flask and the solution heated to boiling. An excess of dilute sulphuric acid is introduced into the mixture and the carbon dioxide, thus set free, completely driven over to the absorption flask and determined as before. Table II shows results obtained by the process.

TABLE II.

| | Barium formate taken. gram. | BaO ₂ H ₂ taken. gram. | BaO ₂ H ₂ found. gram. | CO ₂ found. gram. | CO ₂ calculated. gram. | Error on CO ₂ . gram. |
|----|--------------------------------------|--|--|------------------------------------|---|---|
| 1. | 0·5001 | 0·9302 | 0·1745 | 0·1939 | 0·1935 | 0·0004 + |
| 2. | 0·5033 | 0·9012 | 0·1402 | 0·1953 | 0·1947 | 0·0006 + |
| 3. | 1·0002 | 1·6861 | 0·1793 | 0·3867 | 0·3870 | 0·0003— |
| 4. | 1·0059 | 1·6279 | 0·1093 | 0·3897 | 0·3892 | 0·0005 + |
| 5. | 1·3750 | 2·2529 | 0·1820 | 0·5315 | 0·5320 | 0·0005— |
| 6. | 1·5028 | 2·4419 | 0·1754 | 0·5816 | 0·5814 | 0·0002 + |

These results show plainly that the carbon of formic acid may be determined accurately by the method outlined.

It was found incidentally that ammonia cannot take the place of the sodium hydroxide in this process, probably because the ammonia volatilizes to the absorption flask during the boiling and is acted on by the iodine subsequently used and is thus registered as barium hydroxide.

It is a well-known fact that tartrates are oxidized by permanganates. I have found, however, that when tartaric acid is treated under the conditions of analysis outlined above in acid solution, the oxidation is incomplete; but that oxidation is complete if the tartrate is heated in a solution alkaline with sodium hydroxide and then acidified with sulphuric acid.

The tartrate used was a recrystallized tartar emetic, dried at 100° C. The following results were obtained with such a tartrate by this process.

TABLE III.

| | Tartar emetic taken. gram. | BaO ₂ H ₂ taken. gram. | BaO ₂ H ₂ found. gram. | CO ₂ found. gram. | CO ₂ calculated. gram. | Error on CO ₂ . gram. |
|----|-------------------------------------|--|--|------------------------------------|---|---|
| 1. | 0·5051 | 1·2450 | 0·1709 | 0·2756 | 0·2751 | 0·0005 + |
| 2. | 0·5030 | 1·2226 | 0·1536 | 0·2743 | 0·2739 | 0·0004 + |
| 3. | 0·7509 | 1·7355 | 0·1401 | 0·4094 | 0·4091 | 0·0003 + |
| 4. | 0·7541 | 1·7430 | 0·1410 | 0·4111 | 0·4107 | 0·0004 + |
| 5. | 1·0018 | 2·3456 | 0·2187 | 0·5458 | 0·5456 | 0·0002 + |
| 6. | 1·0005 | 2·2435 | 0·1196 | 0·5451 | 0·5450 | 0·0001 + |

It seems possible to draw the general conclusion from the results recorded that organic substances which are oxidized completely by the permanganate may be determined by the process outlined above. It will also be seen that the use of the rubber stopper in the boiling flask, with due care to prevent its contact with the solution, does not introduce an appreciable error.

Wanklyn and Cooper* and others have noted the fact that potassium permanganate, whether in acid or alkaline solution, will not oxidize all organic substances (acetates, for example), even at the boiling temperature. It is well known that a mixture of concentrated sulphuric and chromic acids has a much wider field of action in oxidizing organic compounds than the permanganate. With hopes of applying this reagent more widely to the determination of organic carbon, the experiments about to be recorded were tried.

Method of Oxidation with Chromic Acid.

A concentrated mixture of chromic and sulphuric acids, although a much more powerful oxidizer than potassium permanganate in aqueous solutions, fails to oxidize completely many organic compounds. Thus Cross and Higgin† have shown that carbohydrates are among the number of organic substances; later Cross and Bevan find that carbohydrates and many other substances are oxidized completely to a mixture of carbon dioxide and monoxide. Messinger‡ has proven that carbon may be determined in organic compounds by passing the mixed products, resulting from the oxidation with chromic and sulphuric acids, through a short combustion tube, filled with granular copper oxide and heated in a furnace—all of which facts have been confirmed in my own experience.

Ludwig§ has observed that the contact of carbon monoxide with a mixture of chromic and sulphuric acids, especially when hot, results in the oxidation of that gas to carbon dioxide. This fact suggested the idea of substituting for the apparatus described above a new form, adapted to retain the first products of oxidation in prolonged contact with the oxidizing mixture. This apparatus, shown in the accompanying figure, by means of which, as the sequel shows, it has been found possible to extend the availability of the oxidizing mixture, is put together

* Phil. Mag. (5), vii, 138.

† Jour. Chem. Soc., 1882, 113.

‡ Ber., xxiii, 2756.

§ Am. Chem. Pharm., clxii, 47.

as follows: A thick walled, round bottom flask of a liter's capacity, serving as an oxidizing chamber, was closed by a rubber stopper with two perforations, through one of which passes the tube of a separating funnel of about 100^{cm} capacity. The tube of this funnel reached nearly to the bottom of the flask and is drawn out at the lower end. A disc of platinum foil is hung in the neck of the flask, nearly closing it, and held in place by a platinum wire passing through the foil and tucked under the rubber stopper where the funnel tube enters. The second hole of the stopper is filled by the exit tube, a glass tube of 0.7^{cm} internal diameter. This tube is expanded just above the stopper to a small bulb which serves to prevent mechanical loss of the solid contents of the flask during the boiling. This tube is joined by means of a rubber connector (provided with a screw pinch cock) to the inlet tube of the absorption flask, which is an ordinary 500^{cm} round bottom flask. This flask is also closed by a rubber stopper with two perforations, through one of which passes the inlet tube described above and through the other the exit tube, which is also enlarged to a small bulb just above the stopper and is closed by a rubber connector and screw pinch cock. The glass ground stopper of the funnel tube is carefully cleaned and lubricated with a thick solution of metaphosphoric acid.

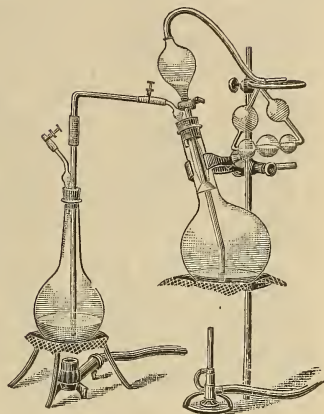

Instead of getting the vacuum by the water pump, it may be gotten almost as quickly and certainly more simply by boiling water in the evolution flask and the barium hydroxide solution in the absorption flask at the same time—both flasks being connected ready for making a determination. When steam issues in good quantity from the exit tube of the absorption flask, the burner is removed from under the evolution flask and its screw pinch cock closed, and then the burner under the absorption flask and its screw pinch cock also quickly closed. The flasks are then allowed to cool.

In making a determination, the organic substance is weighed out in a counterbalanced bulb, so thin that it may be easily broken later and made with a wide mouth for convenience in introducing the solid substance. After the substance is weighed, the mouth of the bulb is sealed by heating in a small blow-pipe flame and the tube introduced into the evolu-

tion flask, together with an amount of pure potassium dichromate, which is known to be in excess of that required to oxidize the organic substance. The flasks are connected, as already described, with an appropriate amount of barium hydroxide solution in the absorption flask and 10^{cm}³ of pure water in the evolution flask and the vacuum obtained (as described above) by boiling both flasks, the boiling being stopped when the water in the evolution flask has decreased to 2 or 3^{cm}³. Naturally, this boiling must be so regulated as not to allow loss of the solid material in either flask. The vacuum obtained, the tube containing the organic substance is broken by shaking the flask, and 20^{cm}³ of concentrated sulphuric acid, previously purified from organic material by heating to the fuming point with a few crystals of potassium dichromate, are run in through the funnel tube, when reduction of the chromic acid soon becomes evident. While still hot, the acid is shaken in the flask violently, the platinum foil hung in the neck serving to protect the rubber stopper. The flask is warmed to approximately 105° C., the highest temperature to which, as shown by Cross and Bevan,* a mixture of chromic and sulphuric acids may be safely heated without the disengagement of oxygen gas. Water is then run in until the crystals of chromic anhydride have disappeared and the danger of the evolution of oxygen is past. The solution is heated to its boiling point, care being taken that it shall not get under pressure, which can easily be observed by opening momentarily the stop-cock of the funnel tube and noting the direction of the flow of water, contained in the funnel. The flask is shaken and heated alternately for five minutes—a period of time which appears to be sufficient to bring about the oxidation of the small amount of carbon monoxide, originally produced. Then more water (60–70^{cm}³) is introduced through the funnel and the stop-cock between the boiling and absorption flasks opened, when the carbon dioxide enters the absorption flask, which is kept cool and shaken as before. The contents of the evolution flask are then heated to boiling and a slow current of air, freed from carbon dioxide by passage through potash bulbs, allowed to enter through the funnel tube to keep the liquid from undue bumping. The boiling is continued for fifteen minutes, after which the excess of barium hydroxide is determined iodometrically and thus the carbon dioxide present estimated as before. Table IV shows results obtained by the treatment of crystallized ammonium oxalate and cane sugar, recrystallized from dilute alcoholic solution, in this manner.

* Jour. Chem. Soc., liii, 889.

TABLE IV.

| Substance taken. gm. | BaO ₂ H ₂ taken. gm. | BaO ₂ H ₂ found. gm. | CO ₂ found. gm. | CO ₂ calculated. gm. | Error on CO ₂ . gm. |
|--------------------------------------|--|--|----------------------------|---------------------------------|--------------------------------|
| <i>Analysis of ammonium oxalate.</i> | | | | | |
| 1. 0.5009 | 1.3534 | 0.1469 | 0.3097 | 0.3101 | 0.0004— |
| 2. 0.5006 | 1.3400 | 0.1308 | 0.3103 | 0.3099 | 0.0004+ |
| 3. 0.5005 | 1.3400 | 0.1343 | 0.3094 | 0.3098 | 0.0004— |
| 4. 1.0002 | 2.5460 | 0.1347 | 0.6188 | 0.6192 | 0.0004— |
| 5. 1.0010 | 2.5192 | 0.1094 | 0.6185 | 0.6197 | 0.0012— |
| <i>Analysis of cane sugar.</i> | | | | | |
| 1. 0.2001 | 1.3926 | 0.1905 | 0.3085 | 0.3088 | 0.0003— |
| 2. 0.2000 | 1.3926 | 0.1936 | 0.3077 | 0.3086 | 0.0009— |
| 3. 0.2001 | 1.3926 | 0.1857 | 0.3097 | 0.3088 | 0.0009+ |
| 4. 0.2014 | 1.3400 | 0.1279 | 0.3111 | 0.3108 | 0.0003+ |

The results are evidently very satisfactory.

The Determination of the Oxygen required to Oxidize an Organic Substance.

Several different methods have been proposed for estimating the oxygen present in organic substances, depending, in general, upon the determination of the oxygen which must be supplied to burn the substance to a known amount of carbon dioxide and water—thus discovering by difference the oxygen originally contained in the substance. Lavoisier is said to have measured directly the oxygen used in burning organic substances; Gay-Lussac and Thénard determined the oxygen used by measuring the amount of potassium chlorate reduced by burning the organic compound; Baumhauer* determined the oxygen used by measuring the volume of oxygen entering the combustion furnace and subtracting the measure of the gas coming from the combustion tube, which was set up according to the well known method for determining carbon and hydrogen; Stromeyer† determined the amount of copper reduced by the ignition of the substance in copper oxide; Ladenburg‡ oxidized the substance by heating in a sealed tube with a known amount of iodic acid, determining at the end of the operation the amount of iodic acid left; Mitscherlich§ has estimated the oxygen in organic substances directly by decomposing the substance by ignition in a stream of chlorine gas, estimating the oxygen content by determining the resulting carbon dioxide and monoxide.

As it has been shown in the work described that carbon may be determined in organic substances by oxidation with chromic and sulphuric acids without the evolution of oxygen gas, it would seem that the determination of the oxygen in the sub-

* Ann. Chem. Pharm., xc, 228.

† Ann. Chem. Pharm., cxixv, 1.

‡ Ann. Chem. Pharm., cxvii, 247.

§ Pogg. Ann., cxxx, 536.

stance might be effected by determining the amount of chromic acid used in the operation, taking into consideration the products of combustion. This can be readily accomplished by taking a weighed amount of pure potassium dichromate as the oxidizing agent and determining, at the end of the operation, the amount of chromic acid left by treatment of the residue with hydrochloric acid, absorption of the chlorine evolved in an alkaline arsenite of known strength and titration of the excess of that substance with decinormal iodine solution.

To test the accuracy of the determination of chromic acid under these conditions of analysis, weighed portions of pure fused potassium dichromate were introduced into a Voit flask, whose outlet tube was sealed to the inlet tube of a Drexel wash bottle, the outlet of which, in turn, was sealed to a Will and Varrentrapp absorption apparatus. An amount of hydrochloric acid, more than enough to completely reduce the chromate (15–40^{cm³} of the strongest acid), was added with 20^{cm³} of strong sulphuric acid and the total volume made up to 120–140^{cm³} of liquid. The sulphuric acid used here was purified from carbonaceous matter (as in the carbon determination above) by heating with a few crystals of potassium dichromate, the excess of which was reduced by holding the acid at a fuming point for about two hours, when a portion diluted with water gave no color with potassium iodide and starch paste. Pure arsenious oxide, in amount slightly in excess of that required to take up the oxygen to be given up by the chromate, was dissolved by the aid of heat in a solution of pure sodium hydroxide, taken in such quantity as to more than neutralize the arsenious acid and the hydrochloric acid used to reduce the chromate, and this solution was introduced into the Drexel wash bottle. The flask was then connected with the wash bottle, using a thick solution of metaphosphoric acid to lute the joint between the flask and its stopper. The absorption apparatus was charged with a dilute solution of sodium hydroxide. Carbon dioxide was generated in a Kipp generator by the action of hydrochloric acid on marble and purified from reducing matter by bubbling through a strong solution of iodine in potassium iodide and finally washed with a solution of potassium iodide alone. A slow stream of this purified carbon dioxide was allowed to enter the inlet tube of the Voit flask, the contents of which were then boiled. When a concentration to a volume of 30–40^{cm³} was reached, the boiling was discontinued and, after cooling and disconnecting the flask, the contents of the receiver were made acid with sulphuric acid and then alkaline with acid potassium carbonate, when the excess of arsenite was determined by titration with decinormal iodine solution. Sometimes during the reduction of the chromic acid, the red fumes of the chlorochromic anhydride volati-

lized to the receiver; but since the chromic acid thus produced is reduced later by the arsenite,* this transfer is of no account in the working of the process. The following results were thus obtained.

TABLE V.

| | K ₂ Cr ₂ O ₇ taken. gram. | As ₂ O ₃ taken. gram. | As ₂ O ₃ found. gram. | K ₂ Cr ₂ O ₇ found. gram. | Error on K ₂ Cr ₂ O ₇ . gram. |
|----|--|---|---|--|--|
| 1. | 5·0002 | 5·1025 | 0·1144 | 4·9447 | 0·0555— |
| 2. | 5·0018 | 5·0799 | 0·0526 | 4·9849 | 0·0169— |
| 3. | 5·0005 | 5·0801 | 0·0582 | 4·9782 | 0·0223— |
| 4. | 5·0013 | 5·0706 | 0·0908 | 4·9365 | 0·0648— |

The cause of the error shown in these experiments was traced finally to too great concentration of the sulphuric acid in the process. When the boiling begins the chromate is reduced gradually and if the evaporation of the water is pushed too rapidly, the sulphuric acid may reach a strength at which it begins to cause the reduction of the chromic acid with the evolution of oxygen instead of chlorine.

The obvious remedy is to conduct the boiling operation more slowly. It was found that, if from 5–6 hours time was taken for the proper concentration of the contents of the Voit flask, the presence of the sulphuric acid worked no harm, as will be seen from the following results. Experiments (1) and (5) were made with 5^{cm³} of sulphuric acid present and the others with 20^{cm³}, as used before.

TABLE VI.

| | K ₂ Cr ₂ O ₇ taken. gram. | As ₂ O ₃ taken. gram. | As ₂ O ₃ found. gram. | K ₂ Cr ₂ O ₇ found. gram. | Error on K ₂ Cr ₂ O ₇ . gram. |
|----|--|---|---|--|--|
| 1. | 1·0004 | 1·0500 | 0·0398 | 1·0014 | 0·0014 + |
| 2. | 1·0007 | 1·0531 | 0·0437 | 1·0006 | 0·0001— |
| 3. | 2·0013 | 2·0501 | 0·0299 | 2·0026 | 0·0013 + |
| 4. | 2·0037 | 2·0727 | 0·0502 | 2·0049 | 0·0012 + |
| 5. | 5·0020 | 5·1002 | 0·0495 | 5·0068 | 0·0048 + |
| 6. | 5·0037 | 5·1018 | 0·0513 | 5·0066 | 0·0029 + |

In applying this method to the determination of oxygen used in the oxidation of an organic substance, the carbon determination was made as already described, the amount of water used being such as to leave 60–80^{cm³} of liquid in the boiling flask after the carbon dioxide had been driven to the absorption flask by boiling. This liquid was then washed into the Voit flask and the chromic acid remaining determined by a second distillation (this time with hydrochloric acid) in the manner described above. In each of the experiments recorded

* Browning, this Journal, 1896, vol. i, 35.

below, 20^{cm}³ of purified sulphuric acid were used in the carbon determination and 35^{cm}³ of hydrochloric acid (sp. gr. 1.2) in the chromic acid determination. The ammonium oxalate used was the pure crystallized salt; the phthalic acid was recrystallized from its water solution and dried for a short time over sulphuric acid; the cane sugar was selected crystals of rock candy, recrystallized from dilute alcoholic solution and dried for a long time over sulphuric acid; the paper was ashless filter paper, dried to a constant weight over sulphuric acid; the tartar emetic was recrystallized from water solution and air dried; the barium formate was prepared by treating formic acid with an excess of pure barium carbonate, filtering hot and allowing the product to crystallize.

TABLE VII.

| Substance taken. | CO ₂ found. | Error on CO ₂ . | K ₂ Cr ₂ O ₇ taken. | As ₂ O ₃ taken. | As ₂ O ₃ found. | Oxygen used. | Oxygen required by theory. | Error on Oxygen. |
|--------------------------------------|------------------------|----------------------------|--|---------------------------------------|---------------------------------------|--------------|----------------------------|------------------|
| gram. | gram. | gram. | gram. | gram. | gram. | gram. | gram. | gram. |
| <i>Analysis of ammonium oxalate.</i> | | | | | | | | |
| 1. 1.0122 | 0.6265 | 0.0001- | 2.0009 | 1.3002 | 0.0000 | 0.1160 | 0.1139 | 0.0021+ |
| 2. 1.0019 | 0.6212 | 0.0010+ | 2.0002 | 1.3517 | 0.0440 | 0.1147 | 0.1128 | 0.0019+ |
| <i>Analysis of phthalic acid.</i> | | | | | | | | |
| 1. 0.1002 | 0.2138 | 0.0014+ | 2.0012 | 1.2004 | 0.0814 | 0.1456 | 0.1448 | 0.0008+ |
| 2. 0.1093 | 0.2324 | 0.0007+ | 2.0000 | 1.1031 | 0.0634 | 0.1582 | 0.1580 | 0.0002+ |
| <i>Analysis of cane sugar.</i> | | | | | | | | |
| 1. 0.2025 | 0.3117 | 0.0008- | 3.0000 | 1.7002 | 0.0796 | 0.2275 | 0.2273 | 0.0002+ |
| 2. 0.4012 | 0.6166 | 0.0024- | 5.0000 | 2.3022 | 0.0366 | 0.4495 | 0.4502 | 0.0007- |
| <i>Analysis of paper.</i> | | | | | | | | |
| 1. 0.3034 | 0.4932 | 0.0010- | 3.5015 | 1.4017 | 0.0879 | 0.3589 | 0.3598 | 0.0005- |
| 2. 0.4523 | 0.7334 | 0.0033- | 5.0035 | 1.8000 | 0.0710 | 0.5368 | 0.5358 | 0.0010+ |
| <i>Analysis of tartar emetic.</i> | | | | | | | | |
| 1. 0.5057 | 0.2671 | 0.0009- | 2.5018 | 1.7000 | 0.0766 | 0.1459 | 0.1462 | 0.0003- |
| 2. 1.0099 | 0.5321 | 0.0030- | 3.5003 | 1.7520 | 0.0198 | 0.2911 | 0.2919 | 0.0008- |
| <i>Analysis of barium formate.</i> | | | | | | | | |
| 1. 1.0079 | 0.3906 | 0.0006+ | 3.0026 | 2.2002 | 0.0496 | 0.1423 | 0.1422 | 0.0001+ |
| 2. 1.5014 | 0.5814 | 0.0005+ | 3.0010 | 1.8080 | 0.0890 | 0.2118 | 0.2118 | 0.0000± |

From these results, it will be seen that the process works with accuracy upon a great variety of organic substances. It was found impossible, however, to determine the elements in bodies which are at the same time volatile and hard to oxidize; for instance, ether oxidizes easily to acetic acid but difficultly beyond that stage; although the liquid acid is oxidized vigorously by chromic and sulphuric acids, the gaseous acid is hardly attacked at the temperature used; naphthalene was also found to be volatilized, and hence not attacked, to such an extent as to render its determination by this process valueless.

In conclusion, the author wishes to express his thanks to Prof. F. A. Gooch for many helpful suggestions.

ART. XLI.—*Some Features of Pre-Glacial Drainage in Michigan*; by E. H. MUDGE.

To reach a definite and satisfactory conclusion in regard to the condition of the pre-glacial surface of a region now deeply covered with drift, is not an easy matter. The best, perhaps, that can be done is to examine the surface of an unglaciated region of like geologic age, and with the knowledge thus gained examine such data as may be obtainable from the covered region.

The lower peninsula of Michigan is such a covered area. In all the glaciated area of North America there is, I think, no region of equal extent, approximating 40,000 square miles, that is so deeply and uniformly covered with drift as this. Except within the southern half of the Carboniferous area, and in the vicinity of its southern rim, there are practically no outcrops in the interior of the state. The glacial mass seems to have concentrated itself upon this territory. Though the general direction of the glacial movement was southwest, that portion of the ice sheet which would naturally have passed over Wisconsin was largely deflected to the south by the valleys now occupied by Lakes Michigan and Huron, and joined with the great body which passed over Michigan,* mingling its volume of drift from the Lake Superior region with that derived more locally from the sedimentary terranes of the lower peninsula. The drift-mantle resulting from these conditions is so deep and so uniformly distributed that any conclusions in regard to the pre-glacial surface must be largely speculative, though we are not entirely without data bearing on the subject.

One thing seems certain. We are quite sure that during the several millions of years between the close of the Carboniferous and the beginning of the ice invasion the surface was exposed to the constant influence of the agents of denudation and erosion—rains, frosts, winds, chemical action and running streams. We conclude, therefore, that the condition of the surface just previous to the ice invasion was not very unlike that which may now be seen in unglaciated regions of similar age. The unglaciated region most suitable for comparison in this case is doubtless the driftless area of Wisconsin, above referred to. With this as a criterion, we may infer that our field was traversed by broad base-level valleys and sharp, ridge-like divides, the latter sometimes cut through by the

* "Driftless Area of Wisconsin," T. C. Chamberlin, Sixth Ann. Report U. S. Geol. Survey.

headwaters of streams, leaving detached erosion blocks, which in some cases had become reduced to fragile erosion towers, ready to tumble to decay. The more level surface was covered with disintegrated rock, not yet borne away. There were no lakes or marshes; these, if any there ever were, having been drained by the cutting down of their outlets. If, however, we would determine the location of the old streams, and join them into a consistent drainage system, we must depend upon such knowledge as an examination of the territory itself may yield us. This is not inconsiderable, though quite fragmentary and indefinite.

Notwithstanding the vigorous glacial action to which the lower peninsula was subjected, the more prominent features of the old topography do not appear to have been entirely obliterated. The greater valleys were not entirely filled, nor were the greater eminences smoothly planed down. The leveling process was left incomplete. Of the old valleys thus left in recognizable shape, that which crosses the state from east to west, and which is now occupied in part by the Saginaw river and its branches, and in part by the Grand and Maple rivers, is the most clearly discernible. It is still a striking topographic feature, and during the departure of the ice sheet it was for a long period the natural outlet of the great glacial lakes farther to the east. The theory that this valley is the modern representative of a far greater pre-glacial valley is by no means new, the same having been set forth especially by Dr. J. W. Spencer.* The evidence on this point is clear. It may be inferred from the great lateral extent of the depression, indicating that it is not of post-glacial origin, and it is clearly proven by a deep boring at Alma, which penetrated about 500 feet of drift and failed to reach the rock surface. There is reason to believe that the axis of the ancient valley was somewhat farther north than the center of the modern depression. The Alma boring is well to the north, while at one point in the bottom of the present river valley near Ionia the rocks come to the surface and project several feet above the river.† Two recent borings at Ionia, near the valley margin, found rock at moderate depths. This would indicate that the modern valley is located over the southern edge of the ancient one, the northern portion having been more completely filled by the flood of glacial debris which was swept into it from that direction. I have, therefore, on the accompanying map, located the ancient river somewhat to the north of the modern streams.

* Quar. Jour. Geol. Soc., November, 1890.

† See the writer's paper in this Journal for November, 1895.

In the same manner two other lesser ancient valleys may be postulated with some confidence. The first of these is represented by the valley of the Thornapple river, which enters the Grand a few miles east of the city of Grand Rapids. The depression occupied by this stream and its branches is rather broad and flat, and within its area there is a large number of small lakes. It is therefore not a product of post-glacial erosion. Borings at Hastings and at other points near the river passed through more than 100 feet of drift without finding rock. That this valley is also a remnant of an older one is a legitimate inference.

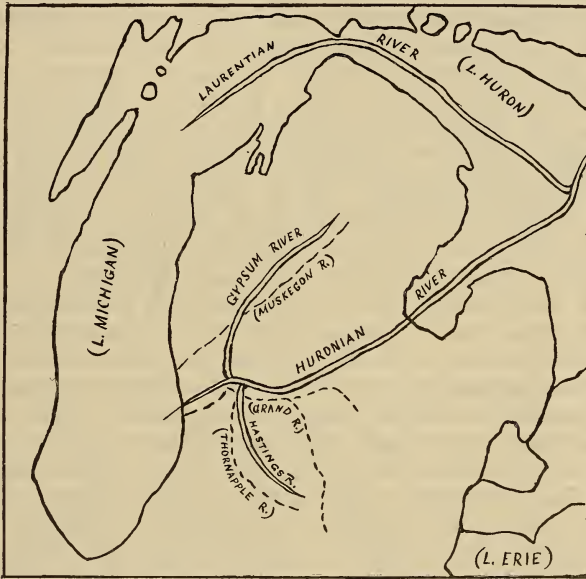

The second ancient valley referred to is buried beneath the valley of the modern Muskegon River. This stream rises in the highlands of the north central part of the peninsula, and flows directly southwest, reaching Lake Michigan only a few miles north of the mouth of Grand River. Its drainage area is peculiar, having a length of about 125 miles, while its lateral extent averages about 25 miles, and at some points is much narrower. That this elongated area is the modern representative of a pre-glacial valley is not claimed with so great confidence as in the case just described, though there is good reason for accepting this hypothesis. It will be noted, in the first place, that there is a large area, tapped by this supposed valley, which must have had a drainage system of some sort. When the central part of the peninsula was a great Carboniferous

swamp, the older and higher land adjoining must naturally have drained into it. Later, when the Huronian River dissected the Carboniferous strata, the drainage from the north must have gathered into a prominent stream at some point and become a branch of the main river. This important branch valley is, in my judgment, represented by the modern Muskegon Valley. Throughout much of the upper part of its course the surface of the valley rises rapidly on either side of its center, attaining an elevation of from 300 to 600 feet within a limit of five or six miles on either side. The limits of the valley may indeed have been determined by the presence of moraines, pushed up from either side by the Saginaw and Michigan glacial lobes, but much of the country is new, and has never been carefully examined, and there are few borings and no rock exposures on which to base an opinion. In the absence of other data it may be proper to assume that the drift-sheet is thinner over the more elevated portions, as in the southern part of the State, in which case we can plainly see in the upper Muskegon Valley a remnant of an old erosion gorge. The general configuration is such as to indicate that this old valley joined the main valley near Grand Rapids,* though the modern river flows into Lake Michigan.

Dr. J. W. Spencer, who has given much study to the subject, supposes that this region drained to the east, which is undoubtedly correct. He has named the main stream across the peninsula the Huronian River, and considers it as a branch of his Laurentian River, which he supposes to have drained the upper part of the Lake Michigan basin. But the location of the two tributaries, occupying the valleys above described, I think has not before been suggested by anyone. I have therefore named the southern tributary the Hastings River, from the chief city within the modern valley, and the northern the Gypsum River, from its coincidence with the supposed strike of the gypsum or sub-Carboniferous strata. The drainage system as thus made out will be clearly understood by an inspection of the map.

Ionia, Mich.

* See the writer's paper on the "Drainage Systems of the Carboniferous Area,"—in *American Geologist*, for November, 1894.

SCIENTIFIC INTELLIGENCE.

I. CHEMISTRY AND PHYSICS.

1. *On the verification of Dalton's law for Solutions.*—It is well known that Van't Hoff in 1886 first drew attention to the fact that the equations representing the generalizations arrived at by Boyle, Gay Lussac and Avogadro in the case of gases, are equally applicable to dissolved substances if the osmotic pressure of the molecules dissolved be substituted for the gaseous pressure. Moreover he not only deduced these conclusions from thermodynamic considerations, thereby giving them increased validity, but he established a thermodynamic relation between the osmotic pressure of a dissolved substance and the molecular lowering of the vapor pressure, or that of the freezing point of the solution. WILDERMANN has now shown that the third gaseous law called the law of Dalton also holds good for dilute solutions. According to Dalton's law the total pressure of a gaseous mixture in a given space is equal to the sum of the partial pressures of the constituents. In a solution of two or more substances it means that the total osmotic pressure of two or more dissolved substances is the sum of the partial osmotic pressures of each of them. Hence from the connection between osmotic pressure and the depression of the freezing point it follows that the total freezing point depression is equal to the sum of the partial freezing point depressions of each of the dissolved substances. In his experiments the author employed the freezing point method on account of the readiness with which mixtures of substances can be examined by means of it. The direct experimental proof of the law consisted in verifying one of the thermodynamical generalizations with which it has been experimentally connected. The thermometers used read, the one to 0.001° and the other to 0.01° . After the freezing point of the water itself had been determined, a certain quantity of a given non-electrolyte, urea for example, was dissolved in it and the freezing point again determined. The second non-electrolyte was then added and the total depression noted which was produced by both electrolytes. The substances used with the urea were resorcinol, cane sugar, dextrose and alcohol. The results are given in tabular form and show that the constant of depression obtained for the second electrolyte is in no way inferior to that obtained when it is dissolved by itself in water. This result proves that the depression produced by the first electrolyte was calculated under a correct assumption, i. e. that the freezing point depression produced by the first electrolyte is independent of the presence of other substances in the liquid.

In a second paper, WILDERMANN gives the results of experiments made to verify the constant of Van't Hoff for very dilute solutions. This constant, i. e., the molecular depression of the

freezing point—was verified for moderately dilute solutions by Van't Hoff himself by means of the equation

$$t = 0.02T^2/w$$

in which T is the absolute temperature, and w the latent heat of fusion of the solvent. If Bunsen's value for w , 80 calories, be taken, the value of the constant v is 1.87, somewhat smaller than 1.878 obtained if 79.6 be taken. Preliminary experiments in 1894-5 gave for alcohol and cane sugar the value 1.84 when obtained with the 0.001° thermometer. Subsequently 1.89 was obtained for cane sugar and resorcinol, 1.87 for urea, 1.86 for milk sugar, 1.85 to 1.86 for dextrose and 1.84 to 1.87 for maltose. In the present investigation, cane-sugar, alcohol, urea, acetone, aniline, phenol, dextrose, resorcinol, maltose and milk sugar, were the substances used, the solutions were very dilute and the observations for temperature were made with 0.001° and 0.01° thermometers, the convergence temperature being both above and below the freezing temperature. The results, which are given in tabular form, show only small deviations from 1.87, the theoretical value. Hence the author concludes that Van't Hoff's thermodynamic equation receives abundant confirmation from the results obtained with dilute solutions, the evidence being even more satisfactory than is the case with most of the generalizations established on the thermodynamic basis.—*J. Chem. Soc.*, lxxi, pp. 743, 796, July, 1897.

G. F. B.

2. *On the Spectrum of Silicon.*—If a silicate be fused on a platinum plate and a highly condensed spark be allowed to impinge upon it,* ARNAUD DE GRAMONT has shown that the spectrum of the spark shows the following lines of silicon: 6969.7 strong, 6342.2 very strong, 5978.9 somewhat strong, 5960.3 distinct, 5948.0 doubtful, 5060.0 and 5045.5 very strong, 4575.7 very feeble, 4568.9 somewhat distinct, 4553.7 distinct, 4131.3 and 4129.2 somewhat strong but diffuse. These wave lengths are the means of determinations not only with the spark and fused salts but also with the spark and silicon electrodes in very pure hydrogen. The most characteristic lines are 6969.7 and 6342.2 in the red and 5060.0 and 5045.5 in the green. The silicon lines last mentioned are much more intense than the adjacent lines of platinum and air. The spectrum obtained by this method is well shown with sodium silicate, not as well by the potassium salt. Both potassium and sodium silico-fluoride show it particularly well, but zinc silicate gives it very imperfectly. Natural silicates if pulverized and fused with sodium carbonate, soon show the pairs of lines in the red and in the green.—*C. R.*, cxxiv, 192-194, January, 1897.

G. F. B.

3. *On the Spark Spectrum of Cyanogen.*—Several reasons have been offered for supposing cyanogen to have a real spectrum. (1) When nitrogen is present, this substance is actually formed in the arc; (2) without nitrogen, carbon itself does not give the

* This Journal, IV, iii, 150, February, 1897.

same spectrum; (3) cyanogen burns with a flame giving a banded spectrum assumed from the foregoing facts to be that of this gas, and (4) this spectrum can be photographed when a condensed spark is passed between electrodes of gold in an atmosphere of cyanogen. HARTLEY has examined this question and concludes that the facts which have been obtained solely from observations on this arc are insufficient to establish the existence of a definite cyanogen spectrum. While certain facts have appeared tending to support the view that the carbon spectrum ought to be given by the flame of burning cyanogen, on the other hand it has been shown that lines somewhat resembling the edges of the cyanogen bands are seen when moistened graphite electrodes in air have sparks passed between them; these lines being intensified if the water used in moistening contains ammonium, calcium or zinc chlorides, developing into bands which become stronger as the solution is made more concentrated. This is explained by the fact that all mineral acids contain ammonia, freshly made sulphurous acid being the only one free from it. Salts of calcium and zinc made with ordinary mineral acids therefore always contain ammonium salts. Consequently if the so-called cyanogen bands are really due to the nitrogen of the ammonia, the spectrum of the graphite electrodes will evidently exhibit the bands more strongly in proportion as the solution used is more concentrated. The following facts are instanced to show that the bands and lines observed are really due to cyanogen and not to carbon alone: (1) The lines on the edges of the bands in the spectrum of a cyanogen flame coincide exactly with those photographed from a potassium cyanide solution, when the spark is passed in an atmosphere of carbon dioxide or of cyanogen, or when this spark is passed between gold electrodes in cyanogen gas; (2) the cyanogen spectrum in the flame of burning cyanogen is accounted for because there is excess of the gas present; and while the temperature of the flame is exceedingly high the gas within it is not in contact with a solid substance, and hence the gaseous compound is heated only to incandescence and immediate decomposition does not occur.—*Proc. Roy. Soc.*, lx, 216–221, 1896.

G. F. B.

4. *On the Electrolytic Solution and Deposition of Carbon.*—It has been noticed already that during the electrolysis of dilute sulphuric acid with carbon electrodes, carbon monoxide and dioxide appear at the anode along with oxygen. COEHN has observed that by suitably altering the concentration of the acid, the temperature and the current density, the electrolysis may be so conducted that practically the sole products at the anode are carbon dioxide and monoxide; the gaseous mixture on analysis giving 70 per cent. CO_2 , about 30 per cent CO and one per cent. oxygen. If this operation be conducted at low temperatures, the anode disintegrates and particles of carbon remain suspended in the acid. At high temperatures, the carbon dissolves in the acid, giving a yellowish and finally a reddish brown solution. This

solution thus obtained may be electrolysed; and if a platinum electrode be employed, a deposit of carbon is obtained at first as a thin colored film and then as a deposit of graphite. The solution itself reduces Fehling's solution and probably contains carbohydrates. On making a cell by means of a lead peroxide plate and a carbon electrode, and on working under the conditions above mentioned, the carbon acts as the soluble electrode. The cell gave an electromotive force of 1.03 volts and yielded a constant current until the lead peroxide was exhausted.—*Chem. Centralbl.*, i, 985, 1896; *J. Chem. Soc.*, lxxii, ii, 241, June, 1897. G. F. B.

5. *On the conversion of Nitrites into Cyanides.*—On heating together sodium nitrite and sodium acetate, the mixture finally explodes. KERF has shown that if the mass be mixed with dry sodium carbonate before heating, it glows and becomes dark colored, evolving hydrogen cyanide. It is then found to contain sodium cyanide as follows:

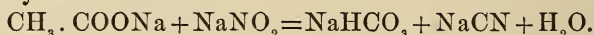

About 25 per cent of the theoretical yield is obtained. Sodium nitrite, heated with formate, gives only sodium carbonate; while with propionate it deflagrates and gives a small amount of cyanide. If sodium acetate or cream of tartar be heated with potassium nitrate a violent explosion occurs, cyanide and cyanate being produced. Nitrite is probably at first formed and this by its action on the acetate gives nitroso-acetate, giving hydrogen cyanide and hydrogen-sodium carbonate.—*Ber. Berl. Chem. Ges.*, xxx, 610-612, April 1897.

G. F. B.

6. *Physics; the Student's Manual for the Study Room and Laboratory*; by LeRoy C. Cooley, Ph.D., Professor of Physics in Vassar College. 12mo, pp. 448. New York, 1897. (The American Book Company.)—This book combines very skillfully class room and laboratory instruction. The principles it treats of are clearly and accurately stated and it cannot fail to become a valuable addition to the existing text-books on elementary physics.

G. F. B.

7. *Action at a distance.*—P. DRUDE in an extended article discusses the mystery of gravitation, and is led to the conclusion that, in order to discover its mode of action, we must seek it in some hitherto undiscovered property of the ether, and he quotes Maxwell's remark in an article on attraction in the *Encyclopædia Britannica*, "The answer to the question of how two bodies act upon each other lies in the incitement of investigation of the properties of the intervening medium." Hitherto we have recognized only one property of a vacuum, that of the propagation of light velocity. The author is hopeful that we shall discover other properties of the so-called ether, which will enable us to build up a system of units which will not depend upon the materials of which the earth is composed but which will be connected with the general properties of the ether. The mean free wave length of the ether atom might serve for the measure of length, for instance. The unit of time would then result from the velocity of light.—*Wied. Ann.*, No. 9, 1897, pp. 1-49.

J. T.

8. *Electrical tension at the poles of an induction apparatus.*—The electromotive force necessary to produce a spark of a certain length has been variously stated by investigators. Heydweiller (*Wied. Ann.*, 48, p. 313, 1893) calls in question Professor Elihu Thompson's statement that a striking distance of 80^{cm} requires a potential difference of about 500,000 volts, and thinks that this is a very great overstatement and that 100,000 volts would be nearer the truth. A. OBERBECK has begun an investigation of the subject and points out that the maximum rise of the curve of electromotive force in an induction coil produced by interrupting the primary circuit should be the starting point in an investigation of this subject. Oberbeck finds that a potential difference of 60,000 volts can produce under certain conditions a stream of sparks of more than 10^{cm} in length.

Experiments in the Jefferson Physical Laboratory with a storage battery of 10,000 cells connected to a Planté rheostatic machine lead the author of this note to conclude that Professor Thompson's estimate is nearer the truth than that of Heydweiller. — *Wied. Ann.*, No. 9, 1897, pp. 109–133. J. T.

9. *Investigation of the Lenard rays.*—TH. DES COUDRES describes a simple method of studying cathode rays in free air. He employs a small transformer for exciting the rarified tubes, the primary of which consists of only three turns of a band of copper, while the secondary consists of about sixty turns. The primary is excited by the discharge of a Leyden jar. The construction of suitable tubes with aluminum windows is fully described. The author concludes that cathode rays behave in the outer air precisely as they do in the rarified space inside the tubes.— *Wied. Ann.*, No. 9, 1897, pp. 134–144. J. T.

10. *Behavior of rarified gases in approximately closed metallic receptacles in a high frequency field.*—Faraday showed that no electricity could be perceived inside a metallic cage, the exterior of which was connected with the ground. H. EBERT and E. WIEDEMANN show that this conclusion is not correct when the space inside the cage is filled with a rarified gas, which is subjected to the oscillations of an electric field. They conclude that in order that an electric charge shall penetrate through the holes of a metallic net into a space surrounded by this net, it is necessary that a rarified gas should exist on both sides of the net. The lighted gas apparently conducts the energy into the inner space.— *Wied. Ann.*, No. 9, 1897, pp. 187–191. J. T.

11. *Cathode Rays.*—In a very important paper Professor J. J. THOMSON discusses the ether theory of the cathode rays and the electrified particle theory. The latter theory has the great advantage that it is definite and its consequences can be predicted, whereas the ether theory depends upon unobserved phenomena in a ether the existence of which is in doubt. Thomson shows by ingenious experiments that the cathode rays carry a charge of negative electricity, and that they are deflected by an electrostatic field. Since they are also deflected by a magnetic field, he

sees no escape from the conclusion that the cathode rays are charges of negative electricity carried by particles of matter. The question then arises, what are these particles—are they atoms, or molecules, of matter in a still finer state of subdivision? Thomson gives a series of measurements to determine these questions. It was found that the electrical carrier or molecule must be small compared with ordinary molecules. (1) The carriers are the same whatever the gas through which the discharge passes. (2) The mean free paths depend upon nothing but the density of the medium traversed by these rays. Thomson favors the view that the atoms of the different chemical elements are different aggregations of atoms of the same kind. In Prout's hypothesis the atoms of the different elements were hydrogen atoms; in this precise form the hypothesis is not tenable, but if we substitute for hydrogen some unknown primordial substance X, there is nothing known which is inconsistent with this hypothesis, which is one lately supported by Lockyer from study of stellar spectra. In the cathode rays we have matter in a new state, in which subdivision is carried very much further than in ordinary gaseous matter—this matter being the substance from which all chemical elements are built up. Thomson computes that if the coil he used were to go on working uninterruptedly night and day for a year, it would produce only about one three-millionth part of a gram of this primordial substance.—*Phil. Mag.*, October, 1897, pp. 293-316. J. T.

12. *Effect of Pressure on Wave Length.*—W. J. HUMPHREYS has an important article upon the above subject in the October number of the *Astrophysical Journal*, giving the results of an investigation carried on at the Johns Hopkins Physical Laboratory. Some of the conclusions reached are as follows:

Increase of pressure causes all isolated lines to shift towards the red end of the spectrum, the shift being proportional to the total increase of pressure, but apparently independent of the temperature. Lines of bands (at least in certain cases) are not shifted but different series of lines of a given element are shifted to different extents, while similar lines of an element suffer equal displacement. The lines of substances having as solids the greatest coefficients of linear expansion have the greatest shifts.

II. GEOLOGY AND NATURAL HISTORY.

1. *Recent publications of the U. S. Geological Survey.**—Monograph Volume XXVI, *The Flora of the Amboy Clays*, by John Strong Newberry; a posthumous work edited by Arthur Hollick, pp. 1-260, plates i-lviii, 1895. This volume, as is explained by the editor was almost completed in the autumn of 1890, and shortly before the author's death in 1892 the manuscript and plates were handed to the editor for completion. Few alterations are made in the original text, and where they are

* Not previously noticed. See list in this Journal, August, 1897, p. 155.

made the editor's initials indicate the fact. A review of Dr. Newberry's contributions to fossil botany is contributed by Prof. Hollick.

The following Bulletins have been issued :—

No. 87, *A synopsis of American Fossil Brachiopoda, including bibliography and synonymy*, by Charles Schuchert, pp. 1-464, 1897. The author recognizes 2053 known species of Brachiopods from the sediments of North and South America, 1922 of which are known from North America. The statistics of original description, geological range, geographical distribution and systematic classification, are fully expressed in carefully prepared lists. The biological development is discussed in a chapter by the author, and Prof. Charles E. Beecher contributes a special chapter on the morphology of the brachia. The author's exhaustive study of the chronological history of the Brachiopods confirms the law of the rapid differentiation of a type of organisms at its beginning, announced by Hyatt in 1883 from a study of Cephalopods, and elaborated in the case of Brachiopods by the present writer in 1895.

No. 138, *Artesian well prospects in the Atlantic coastal plain region*, by Nelson H. Darton, pp. 1-232, plates i-xix, 1896.

No. 140, *Report of progress of the Division of Hydrography for the calendar year 1895*, by Frederick H. Newell, pp. 1-356, 1896. This report opens with a brief discussion of instruments and methods employed in the division.

No. 144, *The moraines of the Missouri Coteau and their attendant deposits*, by James Edward Todd, pp. 1-71, plates i-xxi.

No. 145, *The Potomac formation in Virginia*, by Wm. M. Fontaine, pp. 1-149, plates i-ii, 1896.

No. 148, *Analysis of Rocks with a chapter on Analytic methods, Laboratory of the United States Geological Survey, 1880 to 1896*, by F. W. Clarke and W. F. Hillebrand, pp. 1-306, 1897. The experience and chemical skill of the authors have enabled them to make many important contributions to our knowledge of rock analysis.

H. S. W.

2. *Alabama, Geological Survey*, Eugene A. Smith, State Geologist.—The following three Reports have been issued since our last article (this Journal, vol. iii, p. 350), viz :

Bulletin No. 5. Part I, *A preliminary report on the Mineral Resources of the Upper Gold Belt*, in the Counties of Cleburne, Randolph, Clay, Talladega, Elmore, Coosa and Tallapoosa, by Wm. M. Brewer, Assistant, pp. 1-106, with three plates. Part II, *Supplementary Notes on the most important varieties of the metamorphic or crystalline rocks of Alabama*, their composition, distribution, structure, and microscopic characters, by Eugene A. Smith, Geo. W. Hawes, J. M. Clements and A. H. Brooks, pp. 107-197, 1896.

Iron making in Alabama, by Wm. B. Phillips, pp. 1-164, 1896. This Report is issued as an authoritative handbook of all the conditions which surround the iron-making business in Alabama.

Report on the Valley Regions of Alabama (Paleozoic strata), by Henry McCalley, Assistant State Geologist, Part II, *On the Coosa Valley Region*, pp. 1-862, plates x-xxxv, figures 5-18.—The illustrations are chiefly of ore banks, mines and quarries of iron ores, bauxite and limestone.

3. *Canada, Geological Survey*, Geo. M. Dawson, Director.—The Annual Report (new series), vol. viii (publication number 617) is composed of the separate reports A, D, J, L, R, and S, for the year 1895. They have been issued previously in separate form and several have been already noticed in these pages.

A. (No. 582.) Summary Report of the Geological Survey Department for the year 1896, by the Director, pp. 1-154A.

D. (No. 601) Report on the country between Athabasca Lake and Churchill River, by J. Burr Tyrrell and D. B. Dowling, pp. 1-120D.

J. (No. 541) Report on the Geology of a portion of the Laurentian area lying to the north of the Island of Montreal, by Frank D. Adams, pp. 1-184J.

L. (No. 584) Report on Explorations in the Labrador Peninsula, along the East Main, Kokasoak, Hamilton, Manicuagan, and portions of other rivers, in 1892-93-94-95, by A. P. Low, pp. 1-387L.

R. (No. 616) Report of the Section of Chemistry and Mineralogy, by G. C. Hoffmann, pp. 1-59R.

S. (No. 602) Section of mineral statistics and mines, Annual Report for 1895, by E. D. Ingall, pp. 1-103S.

The maps accompanying the reports in this are, 597, Map of the country between Lake Athabasca and Churchill River, 590, Province of Quebec, geological maps of parts of Joliette, Argen-teuil, Terrebonne and Montcalm Counties, and four maps (585, 586, 587 and 588) of the Labrador Peninsula. There are also 17 plates, pp. 998. Ottawa, 1897.

H. S. W.

4. *Indiana, 21st Annual Report of Department of Geology and Natural Resources, 1896*, W. S. Blatchley, State Geologist, pp. 1-718, plates i-xxxix, and six lithograph maps. 1897.—Besides detailed reports on the geology of several counties the volume contains an elaborate report on the Bedford Oölitic limestone, by T. C. Hopkins and C. E. Siebenthal (pp. 289-427); a chapter on Indiana Caves and their fauna, and a Catalogue of the uncultivated ferns and fern allies (Pteridophyta) and the flowering plants (Spermatophyta) of Vigo County, Indiana, by W. S. Blatchley, the latter containing 853 entries, and several reports on economic resources of the state.

H. S. W.

5. *Fossil Insects of the Cordaites shales of St. John, N. B.*—G. F. MATTHEW has given a description of what he believes to be a new fossil insect, *Geracus tubifer*, n. gen. et sp. (with long suctorial proboscis, but with no head distinct from thorax and no wings and no evidences of appendages) from the Cordaites beds. Whether the specimen be insect or not, the author has in connection with this description brought together figures and references to the original descriptions of the remarkable land fauna, already known from these beds.

The list comprises 2 land snails, 2 Crustacea (Saw Bugs?), 4 Arachnoida, 6 Myriapoda, 2 Insecta-Thysanura, and 8 Insecta-Palæodictyoptera. The specimens come from Plant Beds No. 2 of the Lower Cordaite shales of St. John and neighborhood, in New Brunswick; which are referred to Middle Devonian by Dawson, but by the author are called Silurian, although some of the insects are recognized as like forms found in the Coal Measures.—*Bull. Nat. Hist. Soc., N. B.*, vol. xv, pp. 49-60, figs. 1-4, pl. i-ii, 1897. H. S. W.

6. *Cape of Good Hope, 1st Annual Report of the Geological Commission, 1896*, J. X. Merriman, Chairman, pp. 1-52, Cape-town, 1897.—This volume consists of a few brief reports of the first year's work in preparation of a geological map of the colony. The chief economic interest in the survey centers in seeking for coal beds and in determining the hydrographic conditions of the region. One of the reports by E. H. L. Schwartz, assistant geologist, gives details of the peculiar coal seam at Leeuw River's Poort, occurring in a fissure, the chief part of which cuts the Kooro beds nearly vertically. The mode of occurrence reminds one of the Albertite beds of Nova Scotia, and we would suggest that it may be of similar origin. H. S. W.

7. *Glacial observations in the Umanak district, Greenland*; by GEORGE H. BARTON (*Techn. Quart.*, vol. x, No. 2, pp. 213-244, 1897).—In this Report, B, of the scientific work of the Boston party on the sixth Peary Expedition to Greenland the author has given a vivid narrative, illustrated with numerous photographic reproductions, of the geological and physical features of the region about Umanak Fiord. H. S. W.

8. *Les Variations de longueur des Glaciers dans les Régions arctiques et boréales* par M. CHARLES RABOT. Première partie, Geneva, 1897 (Commission Internationale des Glaciers).—Following in the line of the classical work of Forel upon the glaciers of Switzerland, the author has investigated the glaciers of the extreme north, with respect to the variations in length which they have undergone during the past two hundred years. The countries most particularly considered are Iceland and Greenland.

In the case of Iceland, observations more or less accurate are available for comparison since the close of the 17th century. The author gives many interesting statements about each glacier, and in conclusion sums up the subject as follows: Since the colonization of Iceland by the Normans, the glaciers of the island have considerably increased, this being particularly marked on the southern slope of Vatnajökull, where a large extent of territory has been again covered by the ice. More in detail, he remarks that at the end of the 17th century and the commencement of the 18th, the glaciers were less extended than to-day; but about this epoch, a period of growth was entered upon, interrupted towards the middle of the 18th century in the case of a certain number of the streams by a rather ill-defined period of retreat; but after this, the majority of the glaciers had a remark-

able extension, producing a true invasion which continued during the larger part of the 19th century, and in the case of some streams has not yet been arrested. In the majority of cases, however, after this time of extension a period of diminution set in; this phase appearing to have commenced sooner in the north (1855-1860) than in the south (1880). This movement of retrogression, thus far at least, has not had an amplitude equal to the growth which immediately preceded it. The retreat of the Iceland glaciers presents neither the importance nor the generality of the great phase of diminution established in the Alps between 1850 and 1880. It has rather the character of a secondary phenomenon as compared with the great increase marking the end of the 18th and the larger part of the 19th centuries.

In the case of Greenland, the information is much less exact and minute; so that whatever conclusions are reached must have more or less of a hypothetical value. The author remarks that early authors, deceived by the name of the country, believed that it was truly a "green land" up to the 9th century at the time of the arrival of the first colonists; the idea being that the inland ice was of comparatively recent date. This, however, is a complete error. The earliest document available (13th century) gives a general description of the glaciers which is as accurate as a geologist could write to-day.

The unanimous testimony of the natives affirms that at several points of Danish Greenland, on the west coast up to 72° N. lat., the glaciers have moved forward since the historical period, and Commander Holm gives the weight of his authority to these accounts, at least for the southern portion of the country.

In any case, an increase appears to have been established about the commencement of this century, and to have continued up to the present time, in the greater part of Greenland.

In general, it may be said that particularly in the north the inland ice of Greenland seems at present to be stationary at its maximum point, while in the south a slight diminution manifests itself, but too slightly marked to arrest the progressive movement of the ice noted by Commander Holm. Certainly, during the middle of this century, there is no phase of retreat to be noted which can be compared in extent or duration to that in the Alps. On the contrary, during this period, at least on certain local glaciers, particularly of Disko and Upernavik, a progression has been noted. Observations on Jan Mayen (71° N. lat.) show that the glaciers of Beerenberg have progressed since the end of the 17th century, as is true of a majority of those of Iceland.

9. *Esquisses Sélénogiques*, II, par W. PRINZ (from *Ciel et Terre*, xviii).—The author has carried on an extended and interesting series of studies in regard to the surface features of the moon, and in this, his second paper, he mentions some of the more prominent of them, particularly with reference to their similarity to certain analogous features of the earth. For example, he discusses in detail, with a number of figures, the craters of the

Hawaiian Islands, also those of Java, Iceland, etc.; further the volcanic troughs of East Africa. The resemblance brought out in certain salient peculiarities is very striking, and it is rightly urged that a comparative study of the lunar and terrestrial surfaces in these and similar directions is likely to lead to a much better knowledge of the moon's history and a safer interpretation of what the telescope reveals.

10. *Experimental Morphology*; by C. B. DAVENPORT, Ph.D. Part First, Effect of chemical and physical agents upon protoplasm. New York, 1897 (The Macmillan Company).—The thoroughness which characterizes this important treatise renders it the most useful annotated bibliography of the subject which has appeared. But it is far more than an expanded bibliography. With a good sense of proportion, Dr. Davenport has placed at the command of biologists, not merely the results which have already been secured in this fascinating field, but he has pointed out certain directions which new investigations ought to pursue if they are to be fruitful. The sequence of subjects does not commend itself to us as in all respects the best, for it appears as if the effect of molar agents and of varying moisture upon protoplasm might well precede instead of follow the action of chemical agents and the molecular forces, but, aside from this, one can go with the author along a straight path, until he comes to the end of this part, now before us, namely, the action of light and heat upon protoplasm.

The general considerations on the effects of chemical and physical agents upon protoplasm, which constitute the closing chapter of this part, are carefully stated, and keep on relatively safe ground: they are at the same time of a distinctly suggestive character which must aid in carrying out the chief wish of the author, namely, the stimulation of further inquiries in this attractive and fertile field. Botanists owe to Dr. Davenport very sincere thanks for the exhaustive manner in which he has presented the botanical side of his subject.

G. L. G.

III. MISCELLANEOUS SCIENTIFIC INTELLIGENCE.

1. *Geological Lectures of Harvard University*.—Dr. HANS REUSCH, Director of the Geological Survey of Norway, has been appointed to the Sturgis-Hooper Professorship of Geology in Harvard University, left vacant since the death of Professor J. D. Whitney, a year ago. Dr. Reusch will deliver two courses of lectures. During the first half year he will treat of Vulcanism: volcanoes and eruptive rocks in general; earthquakes and movements of the earth's crust. In the second half year, he will consider the Geology of Northern Europe, and its relations to general geology. These lectures will be given in the Museum, where the Whitney geological library will be immediately accessible. The third hour of each week will be set apart for seminary work, with reports and discussions on geological literature. In the spring,

Dr. Reusch proposes to take part in instruction of advanced students in the field.

2. *The Calculus for Engineers*; by JOHN PERRY, F.R.S., Professor of Mechanics and Mathematics in the Royal College of Science; pp. 378. London and New York, 1897 (Edward Arnold).—This is a work written with much freshness and even, it may be said, vivacity. Every step is illustrated by a profusion of applications to problems of engineering, and the question which the academic beginner in Calculus is so often constrained to ask "what is it all good for" would never suggest itself in reading this text-book. Without sacrificing anything of thoroughness the book is remarkably free from the abstruseness which is so blinding to all but the born mathematician and seems much better fitted than the usual text-book to make the Calculus real to all classes of students as well as engineers.

W. B.

3. *Ostwald's Klassiker der Exakten Wissenschaften*. Leipzig (Wilhelm Engelmann).—The latest additions in the department of physics to this excellent library of scientific classics are numbers 81, 86 and 87. These give respectively Series I and II (1832), Series III to V (1833) and Series VI–VIII (1834) of Faraday's Experimental investigations of Electricity (Experimental-Untersuchungen über Elektrizität).

Grundprobleme der Naturwissenschaft: Briefe einer modernen Naturforscher von Dr. ADOLF WAGNER, pp. 1–255, Berlin, 1897.

OBITUARY.

VICTOR MEYER died on the 8th of August, 1897, in the 49th year of his age. After studying chemistry with Bunsen at Heidelberg and with Baeyer in Berlin, he was called in 1872 to the Zürich Polytechnic, from which place he went in 1885 to Göttingen and in 1889 to Heidelberg, on the retirement of Bunsen. As an investigator, whether in the field of physical or organic chemistry or as an experimentalist, he stood in the first rank. His investigations on the nitro-paraffins in 1872 and on the isonitroso compounds in 1882, his discovery of the two isomeric benzil di-oximes in 1888, which laid the foundation of our knowledge of the stereochemistry of nitrogen, as well as his discovery of thiophene with its numerous derivatives in 1882, may serve as examples of his organic work. His air-displacement method of determining vapor density, devised in 1878, was one of the most ingenious and valuable methods ever given to chemistry. His "Lehrbuch der Organischen Chemie," written in 1891, in connection with Jacobson, is in many respects the most valuable treatise on the subject. The later years of his life were clouded by ill health, but he continued his intense activity without the rest he needed. This brought on insomnia and led to his early death. Though he had accomplished so many and so brilliant achievements in his favorite science, still greater things were promised in his future. His loss to chemistry is well nigh irreparable.

DOUBLY TERMINATED GREEN CYANITE CRYSTALS



A NEW FIND IN NORTH CAROLINA.

We sent a collector to North Carolina recently with instructions to secure every obtainable specimen of this most interesting find (shortly to be described by Prof. Pratt). The crystals are of rich grass-green color and quite transparent, with brilliant terminations; they range in size from $\frac{1}{2} \times \frac{1}{2}$ inch up to $1\frac{1}{4} \times 2\frac{1}{4}$ inches, a few coarser crystals being even as long as $3\frac{1}{2}$ inches. The number of really fine crystals is exceedingly limited, and as our collector exhausted the locality, no more can be had. 50c. to \$2.50.

OTHER CHOICE NORTH CAROLINA MINERALS.

Columbite. A few, excellent, stout crystals, one inch to over three inches long, 50c. to \$5.00. **Zircon** crystals from a new locality, $\frac{1}{2}$ to over one inch, with *a* and *u* planes; brilliant, sharp, attractive, cheap. 5c. to 50c. **Amethyst**, beautiful groups of crystals, 10c. to \$2.00.

WONDERFUL NOVA SCOTIA STILBITES AND CHABAZITES.

We obtained during October a small lot of the finest large Chabazites and sheaf stilbites we have ever seen from Nova Scotia. \$1.00 to \$3.50.

BEAUTIFUL SATINY EPSOMITE.

From one of California's quicksilver mines we have just received fifty vials filled with superb satiny fibres of snowy Epsomite three to four inches long. 35c. to 75c. Also a few pieces of the rare **Mountain Leather**; 10c. to 50c.

OTHER RECENT ADDITIONS:

California Halite, in clear, octahedral crystals; 25c. to \$1.00.

Arizona Cuprite. Choice groups of modified Octahedrons, 50c. to \$3.50.

Arizona Red Wulfenite and Vanadinite, a few fine specimens from an old collection.

Endlichites from New Mexico—surpassingly fine groups of large, gemmy, yellow crystals, \$2.00 to \$10.00.

Arkansas Quartz. Clear and exceedingly slender crystals, single and in groups, 5c. to \$2.00.

Large Pyrite Crystals from Joplin, a new find, 25c. to \$2.00.

Diaspore. A dozen splendid groups of large crystals from Chester; \$2.50 to \$12.50.

Tilly Foster Chondrodites, Clinocllore, Brucite, etc. from the collection of the superintendent of the mine, which we purchased entire.

New Jersey Rhodonites. A very few little groups, exceptionally good in color and crystallization; 75c. to \$1.50.

Danburite from Russel. A good lot of well crystallized specimens; 25c. to \$2.50.

Idaho Opalized Wood, remarkably fine, in complete sections; 50c. to \$7.50.

FALL BULLETIN now in press; free on application.

124 pp. ILLUSTRATED CATALOGUE, 25c. in paper; 50c. in cloth.

44 pp. ILLUSTRATED PRICE-LISTS, 4c.; Bulletins and Circulars free.

GEO. L. ENGLISH & CO., Mineralogists,
64 East 12th St., New York City.

CONTENTS.

| | Page. |
|---|-------|
| ART. XXXVII.—Geology of Southern Patagonia : by J. B. HATCHER | 327 |
| XXXVIII.—Some of the large Oysters of Patagonia; by A. E. ORTMANN. (With Plate XI.) | 355 |
| XXXIX. — Former Extension of the Appalachians across Mississippi, Louisiana, and Texas; by J. C. BRANNER .. | 357 |
| XL.—Combustion of Organic Substances in the Wet Way; by I. K. PHELPS | 372 |
| XLI.—Some Features of Pre-Glacial Drainage in Michigan; by E. H. MUDGE | 383 |

SCIENTIFIC INTELLIGENCE.

Chemistry and Physics—Verification of Dalton's law for Solutions, WILDERMANN, 387.—Spectrum of Silicon, A. DE GRAMONT: Spark Spectrum of Cyanogen, HARTLEY, 388.—Electrolytic Solution and Deposition of Carbon, COEHN, 389.—Conversion of Nitrites into Cyanides, KERP: Physics, Student's Manual for the Study Room and Laboratory, COOLEY: Action at a distance, P. DRUDE, 390.—Electrical tension at the poles of an induction apparatus, A. OBERBECK: Investigation of the Lenard Rays, TH. DES COUDRES: Behavior of rarified gases in approximately closed metallic receptacles in a high frequency field, H. EBERT and E. WIEDEMANN: Cathode Rays, J. J. THOMSON, 391.—Effect of Pressure on Wave Length, W. J. HUMPHREYS, 392.

Geology and Natural History—Recent publications of the U. S. Geological Survey, 392.—Alabama, Geological Survey, 393.—Canada, Geological Survey: Indiana, 21st Annual Report of Department of Geology and Natural Resources, 1896: Fossil Insects of the Cordaites shales of St. John, N. B., G. A. MATTHEW, 394.—Cape of Good Hope, 1st Annual Report of the Geological Commission, 1896: Glacial observations in the Umanak district, Greenland, G. H. BARTON: Les Variations de longueur des Glaciers dans les Régions arctiques et boréales, C. RABOT, 395.—Esquisses Sélénogiques, W. PRINZ, 396.—Experimental Morphology, C. B. DAVENPORT, 397.

Miscellaneous Scientific Intelligence—Geological Lectures of Harvard University, HANS REUSCH, 397.—Calculus for Engineers, J. PERRY: Ostwald's Klassiker der Exakten Wissenschaften, 398.

Obituary—VICTOR MEYER, 398.

Established by BENJAMIN SILLIMAN in 1818.

THE
AMERICAN
JOURNAL OF SCIENCE.

EDITOR: EDWARD S. DANA.

ASSOCIATE EDITORS

PROFESSORS GEO. L. GOODALE, JOHN TROWBRIDGE,
H. P. BOWDITCH AND W. G. FARLOW, OF CAMBRIDGE,

PROFESSORS O. C. MARSH, A. E. VERRILL AND H. S.
WILLIAMS, OF NEW HAVEN,

PROFESSOR GEORGE F. BARKER, OF PHILADELPHIA,

PROFESSOR H. A. ROWLAND, OF BALTIMORE,

MR. J. S. DILLER, OF WASHINGTON.

FOURTH SERIES.

VOL. IV—[WHOLE NUMBER, CLIV.]

No. 24.—DECEMBER, 1897.

WITH PLATE XII.

NEW HAVEN, CONNECTICUT.

1897.

TUTTLE, MOREHOUSE & TAYLOR, PRINTERS, 125 TEMPLE STREET.

AN INEXPENSIVE AND ACCEPTABLE CHRISTMAS GIFT

Is a small **COLLECTION OF MINERALS**, handsomely cased in a polished oak compartment cabinet, with descriptive list. 75c. to \$12.40. Price List of Collections free.

AN OPAL, Topaz, Garnet, Olivene or other gem costing \$1.00 and upwards, makes a desirable present. Send for list.

POLISHED FLAT PAPER-WEIGHTS AND CUBES, beveled edges and nicely polished on all sides, \$2.00 to \$3.00 each. *Opalized Wood, Banded Agate, Moss Agate, "Tiger Eye,"* etc.

CRYSTAL PAPER-WEIGHTS.

The following are selected from over one thousand minerals as being inexpensive, natural crystallizations of unusual beauty, and making very handsome ornaments. They are mentioned in the order of their relative attractiveness. Specimens neatly shaped, about 2x3 inches, are worth from 25c. to 75c. each, according to crystallization.

Tourmaline var. Rubellite. Slender pink crystals in a lavender Lepidolite rock, from San Diego, Cal., U.S.A.

Group of bright, clear crystals. (See illustration, Kansas.)

Group of purple crystals, clear and of cubic form.

Masses of brilliant coal-black crystals. From the Island of Elba.

"COMPLETE MINERAL CATALOGUE."

Over 160 pages, with 40 splendid engravings. The largest and best ever published; more and better illustrations; better paper and printing; more useful matter, conveniently arranged.

PRICES of I. *New Minerals*; II. *Collections, Scientific, Practical and Elementary*; III. *Minerals Sold by Weight for Use in Chemical and Technical Laboratories*; IV. *Meteorites*; V. *Gems and Polished Specimens*; VI. *Books on Mineralogy and Geology*; VII. *Mineralogical Supplies*.

TABLES VIII. *An Alphabetical Index and Price-List*; IX. *Classified List giving Name, Composition and Form of all known Mineral Species and Varieties, with Supplement*; X. *A Complete Metallic Classification of Minerals, showing the Natural Combinations of the Metals*.

Invaluable alike to teachers, students, investigators, mining experts, chemists, and all desiring a brief reference book containing useful information in a condensed form.

Prices, postpaid, paper bound, 25c.; handsome cloth binding, 50c.; calf, interleaved, \$1.00. (Cloth or paper copies half-price to schools ordering twelve or more.)

Dr. A. E. FOOTE,

WARREN M. FOOTE, Manager.

1317 Arch Street, Philadelphia, Pa., U. S. A.

Established 1876.

THE

AMERICAN JOURNAL OF SCIENCE

[FOURTH SERIES.]

ART. XLII.—*A Microsclerometer, for determining the Hardness of Minerals* ;* by T. A. JAGGAR, JR., Cambridge, Mass. (With Plate XII.)

Introduction: the definition of "hardness."

THE hardness of minerals and metals has been investigated by the following methods :

ABRASION-TESTS.

Scratching by hand: (Werner, Häuy, Mohs, Breithaupt, Cohent†, etc.)

Drawing mineral under a point:

- (a) H. = weight on point— (Seebeck, Franz, Grailich and Pekarek,‡ Exner§).
- (b) H. = weight to draw mineral (inversely)—(Grailich and Pekarek).
- (c) H. = number of abrading movements—(Grailich and Pekarek).

* This research has been carried on in the petrographical laboratory of Harvard University, Cambridge, Mass.; the author is much indebted to Professor J. E. Wolff, Dr. Charles Palache, Mr. L. W. Page and Professor Victor Goldschmidt, of Heidelberg, for advice and assistance. For the admirable mechanical execution of the instrument, as well as for many valuable suggestions, I have to thank Mr. Sven Nelson, of Cambridge, to whose skill as an instrument maker no words of mine can do justice.

† v. Rosenbusch, Mikros. Physiographie, I, p. 258.
‡ Sitzungsber. d. k. k. Akad. Wien, xiii. 1854 (contains complete bibliography of earlier papers).
§ Preisschrift, Wien, 1873.

Drawing point over mineral :

- (a) H. = weight to draw point (inversely)—(Franz).
 (b) H. = weight on point—(Turner*).

Grooving with a standard edge :

H. = depth of groove—(Pfaff †).

Boring with a standard point :

H. = number of rotations—(Pfaff †).

Grinding with a standard powder :

- (a) H. = period required for polish (inversely)—(Behrens §).
 (b) H. = loss of volume (inversely)—(Rosiwal ||).
 (c) H. = comparative loss of four substances (inversely)
 (Jannettaz and Goldberg ¶).

STATIC PRESSURE-TESTS.

Compressing lens on plate of substance :

- (a) H. = limit pressure per unit of surface—(Hertz**).
 (b) H. = " " " " multiplied by the cube
 root of the radius of curvature—(Auerbach ††).

Compressing a point into a surface :

- (a) H. = weight to reach a standard depth—(Calvert and
 Johnson ††, Bottone §§).
 (b) H. = volume of indentation (inversely)—(U. S. Ordnance
 Tests |||).

Reference to the foregoing table shows a wide diversity of method, all designed to measure the resistance which a substance opposes to permanent deformation; all come within the scope of four processes utilized as the measure of such deformation, viz :

(1) Abrasion, (2) Penetration, (3) Friction, (4) Fracture.

Of the eighteen authors mentioned, thirteen used abrasion (76 per cent); friction was used as an alternative (and found inadequate) by two of these. All were mineralogists except Turner, who was a practical metallurgist. The five authors who used static pressure as a test of hardness (penetration and fracture) were physicists and metallurgists, and in all five cases

* Proc. Phil. Soc., Birmingham, v, 1886.

† Sitz. k. k. Bayer. Akad., 1883.

‡ Sitz. k. k. Bayer. Akad., 1884.

§ Anleitung zur Mikrochemische Analyse, 1895.

¶ Verhandl. k. k. Geol. Reichsanstalt, 1896, xvii, 475.

¶¶ Assoc. Franç. p. l'Avanc. d. Sc., 9 Aug., 1895.

** Verhandl. Berlin Phys. Gesells., 1882. †† Wied. Ann., 1891, 1892, 1896.

†† Phil. Mag., xvii, 114.

§§ Chem. News, 1873, xxvii.

||| Report of experiments on metal for cannon, U. S. Ordnance Dep't, 1856.

objection has been made to the results obtained on the ground of the interference of tenacity and plasticity. Dana has stated concisely the generally accepted definition of the mineralogists: "Hardness is the resistance offered by a smooth surface to abrasion."

For practical purposes it has been demonstrated that when softer substances are abraded by a very hard substance, other conditions being constant, the amount of abrasion suffered varies with the hardness of the abraded substance. For obtaining values relative to an empirically selected abrader, it is obvious that any one of the numerous variable conditions in the process may be selected for functional purposes, provided all the other conditions are maintained constant. What is required, then, is an absolutely defined abrading agent, a method, one condition, variable with the resistance to abrasion, selected as functional, and devices for maintaining the others absolutely constant. The values obtained would be relative to the hardness of the abrader: this is a point that seems to have been frequently overlooked. Attention has been called, in the text-books,* to the fact that the results of sclerometry show the hardness differences between the lower members of the Mohs scale to be much less than between the harder members, where the differences are said to be enormous, as shown by the great length of time requisite for polishing the harder gems, etc. It must be remembered, however, that when the diamond scratches quartz there is interaction, the phenomenon of the scratch is a relative one; if sufficient force is applied the diamond may be perceptibly abraded as well as the quartz. On the basis of the definition that hardness is the resistance to abrasion by diamond, diamond is almost infinitely harder; but assuming hardness to be the molecular or atomic tenacity, we must have a means for measuring that tenacity in absolute terms of energy expended before we may be sure of the actual differences between different substances.

The hardness of a substance as expressed in resistance to scratching, is, in the case of fine-granular aggregates, dependent on the fineness of the particles, the interlocking or loose structure, and the strength of the cement. If such an aggregate as, for instance, chalk is scraped with a tool, we overcome the tenacity of the particles and produce a scratch: if the substance were an aggregate of diamond particles the scratch would still be produced. If the particles are so rigidly interlocked that the tool does not overcome their tenacity, a scratch will not be produced by reason of a separation of the fragmental particles: yet we know that the soft carbonate will be scratched, and the hard carbon will resist. The first case was

* Tschermak, p. 139.

mechanical structure, the second atomic structure. Again, if a mass of amorphous carbon of low specific gravity is heated in a crucible, crystalline graphite needles are formed, of somewhat higher specific gravity and hardness; if enclosed in a globule of molten iron, which expands suddenly on solidification, and so subjects its inclusions to great atomic pressures, Moissan* has shown that the carbon crystallizes in the form of carbonado and diamond, of very high specific gravity and hardness. The substance in this case is a single element throughout, its atom has retained a constant weight but the molecule has continuously increased in weight under pressure, hence the number of atoms in the molecule has increased with the hardness. This accords with the determinations by Bottonet† that the hardness of metals varies as the specific gravity divided by the atomic weight, which quotient, as Turner‡ has pointed out, varies directly as the number of atoms in a unit space.

Atomic structure in the element; atomic and molecular structure in the crystalline compound; atomic, molecular and sub-microscopic structure in the amorphous or crypto-crystalline substances; atomic, molecular (sub-microscopic) and mechanical structures in the crystalline or fragmental aggregates:—all of these influence hardness as measured by physical abrasion tests; hence for comparative results of scientific value it is important that definite crystals or wholly amorphous substances be selected. If this is done, abrasion tests, delicately conducted, may give very valuable data concerning the intimate structure of solids: Exner§ has shown very interesting relations between the directions of resistance to abrasion and crystalline form: Pfaff|| has barely touched upon a wide field of research in his experiments on the mean hardness variations of minerals in isomorphous series, and the relation of the cohesion constants to the other physical properties. And, finally, as an aid to the differentiation and determination of the crystalline minerals, there is no reason why a thoroughly defined method may not give very constant results.

Former instruments have had three chief sources of error: (1) personal variability due to using "visibility" as determinant; (2) inequalities of mineral surface; (3) undefined details of instrument. To eliminate (1), the depth of abrasion should be definite and measurable: to eliminate (2), the surface should be artificial and defined, and the boring method, where only a very small portion of the surface is initially touched, should be used: this, at the same time, gives a mean value for all directions in the surface; to eliminate (3), every part of the

* Comptes Rendus, 1894 and 1895.

† Loc. cit. ‡ Loc. cit. § Loc. cit. || Sitz. k. k. Bayer. Akad., 1884, p. 255.

instrument, including the abrader, should be minutely defined, and, for comparative determinations, an empirical standard should be adopted.

The Microsclerometer.

The author's object in the present research is to describe an instrument so precisely adjusted as to eliminate these earlier sources of error. The quality which it is proposed to measure is the resistance opposed by a body to the removal of particles of its substance by a defined diamond point, moving in contact with it under uniform conditions. The instrument is applied to the microscope, so that it may be used for either thin sections or crystal faces; it is believed that the tests described will eventually be of determinative value in petrography. The adjustments of the instrument are such that any of the variable elements in the process of abrasion may be made functional while the others are maintained constant; but the best movement for obtaining a mean value is the rotary movement described by Pfaff, the number of rotations of the boring point indicating the hardness of the substance relative to the abrading point.

The instrument is shown in Plate XII, adjusted to the large Fuess microscope No. 1. Fig. 1 shows the plan, and fig. 2 the vertical elevation. The principle of the instrument is as follows: A diamond point of constant dimensions is rotated on an oriented mineral section under uniform rate of rotation and uniform weight to a uniform depth. The number of rotations of the point, a measure of the duration of the abrasion, varies as the resistance of the mineral to abrasion by diamond: this is the property measured. The instrument consists of the following parts:

- (1) A standard and apparatus for adjusting to microscope.
 - (a) Foot adjustments, (b) Rotating adjustments,
 - (c) Lifting adjustments, (d) Fixing adjustments.
- (2) A balance beam and its yoke.
- (3) A rotary diamond in its end.
- (4) Apparatus for rotating uniformly.
- (5) " " recording rotations.
- (6) " " locking and releasing.
- (7) " " recording depth.

The instrument described admits of measurement with any one of the four variables, rate, weight, depth or duration. The last has been found most practical, because it gives the highest values and hence admits of the most delicate gradation.

The Standard.—The yoke *y* is supported on a brass column, which slides in an outer tube, and may be raised or lowered by

a worm at the side. The foot-block F fits the left prong of the U-shaped microscope foot. The distance to which it may be slid on this prong is limited by a set-screw n , and a second thumb-screw t binds it in place. The outer tube T, with all the apparatus which it supports, rotates on the surface of the foot-block F, and this rotation may be given fine adjustment by the graduated barrel and screw R which presses against a projection o from the foot-plate f of the outer tube. The vertical rotation-axle passing through F may be made rigid in any position by the thumbscrew t_1 . A V-shaped extension of the foot-plate f , holds the sleeve in which rotates the main pulley-bearing shaft q . The small pulley at the lower end of this shaft is connected by a belt with the power, represented in Plate XII as a disc and crank for rotation by hand. In the author's latest experiments a clockwork motor has been used.

The Balance Beam.—The beam, b , pivoted at a , is counterpoised by a weight adjustable by the screw, c . The beam consists of an upper and lower lath of brass, the space between being destined to receive the pulley system for rotating the diamond. The indicator arm bears an adjustable pendular counterpoise h at its lower end, to counteract the effect of the "top-bumper" on the beam. This arm passes through a slot in the lower plate of the pole, y .

The Diamond.—The diamond used is a cleavage tetrahedron with a perfect point. The cleavage tetrahedron may be obtained in duplicate in great perfection among the "cleavings" used for making diamond cutters and pencils. The tetrahedra are especially valued for their pure points. As each tetrahedron has four points, it is not difficult to find a point of perfect form among relatively few specimens. The points are turned upward in the field of the microscope successively, under a high power (No. 7) until one is found which shows the three edges to the uppermost focus of the instrument, converging to a perfect point; the diamond selected is centered in its brass mount by soldering it in first roughly, and then turning down the brass in a jeweler's lathe about the diamond point as a center. The diamond D thus mounted is held in a chuck by three radial centering screws. This chuck is attached to a vertical steel spindle which passes through the pulley, p_2 , and its pinion, and terminates in a jewel bearing against a smooth diamond plate in the upper lath of the beam, just under the point midway between the two weight pans, w . The pans are separated in this fashion and two weights used, in order to leave space for the microscope objective, which, as will be seen, is focussed down close to the micrometer scale, m . The superficial angle made by the two edges of each face of the diamond at its point was measured in the microscope by

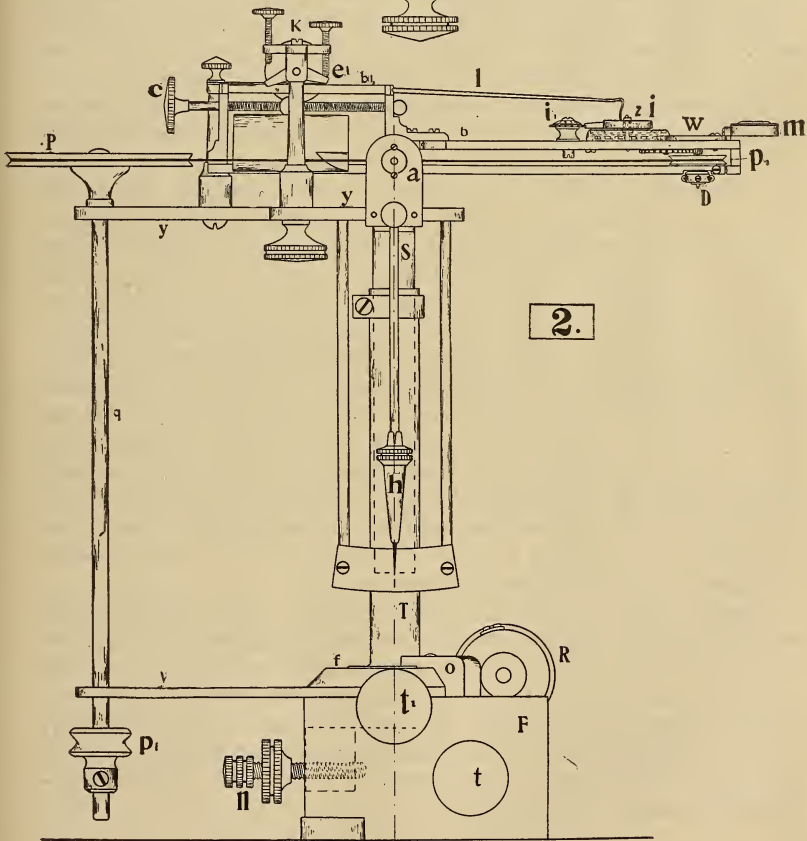
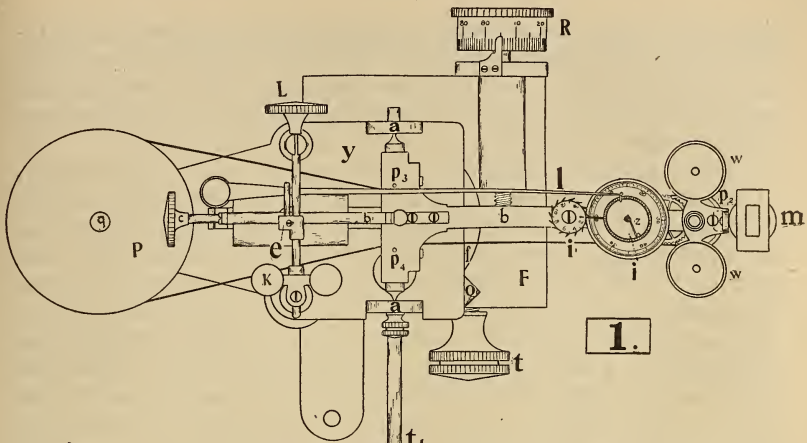

Figures 1 and 2.

focus levelling in the ball-and-socket clip,* followed by rotation after centering the point to the cross-hairs: the angle in each of the three faces was found to be 62° —showing that each face is not a perfect equilateral triangle but possesses a slight bulge or rounding.

Apparatus for rotating.—To the upper end of the shaft, q , is attached a larger pulley, P : the shaft may be raised or lowered freely in the lower sleeve with the rest of the apparatus. The pulley, p_2 , on the diamond spindle, is connected by a fine silk belt with p : the tension of the belt is prevented from interfering with the action of the balance by two small pulleys, p_3, p_4 , rotating within the beam exactly in the pivot axis, and separated by a distance equal to the diameter of p_2 . The belt tension from without is thus applied to the balance system in its axis of rotation, and thus only has the effect of adding to the sensitiveness of the balance by assuming a portion of the weight which otherwise would rest wholly on the pivot bearings. Torsional strains are obviated by the parallelism of the two portions of the belt between p_3 and p_2 , and p_4 and p_2 .

Apparatus for recording rotations.—The rotations of the diamond spindle are reduced $1/60$ by two pinions and two gear wheels of the ordinary watch pattern. Over the second gear is a dial divided into sixtieths: the spindle from this wheel passes through a sleeve in a brass indicator plate, i , which acts as a hand: in this a steel spring, z , presses on the spindle, forming a friction bearing. The outer border of this plate carries a crown milling, against which presses the bent extremity of the spring lever, l . When l is pressed down it engages with the milled edge and the spindle rotates within the sleeve without rotating the indicator, i ; when l is released, the tension of the spring, z , on the spindle is sufficient to cause this to rotate i , and each division of the dial indicates one complete revolution of the diamond. A graduated toothed wheel, i_1 , is rotated intermittently on each complete rotation of i by the latter's index arm, recording the sixties up to fifteen revolutions—making a total of 900 revolutions of the diamond possible without renewed observations.

Apparatus for locking and releasing.—The locking apparatus affects the balance and the recording apparatus simultaneously. A half rotation of L causes an eccentric, e , to press upon the bar, b , above the counterpoise, and at the same time to press down the spring lever, l , and thus check the indicator, i . The adjustment of the lock is regulated by the thumb-screws, k , which limit the rotation of L by checking an angle-piece attached to the L shaft.

* See this Journal, III, 1897, p. 129.

Apparatus for recording depth.—To the end of the beam on its upper side is pivoted horizontally a ring which may be inclined about the symmetry axis of the beam. In this fits a circular plate, *m*, bearing a transparent Zeiss micrometer glass (5^{mm} divided into 100 parts). The plate, *m*, is rotary in the ring, so that the micrometer scale may be turned in any azimuth. This device is so adjusted that the micrometer scale is visible in the field of the microscope at the point exactly 10^{mm} from the axis of rotation of the diamond point: this is one-sixth of the distance from the diamond axis to the beam pivots, *a*, hence any downward movement at the diamond point is magnified by 1/6 at the micrometer. Hence if the microscope is focussed on the micrometer, before and after boring with the diamond, the depth so measured by the fine adjustment screw of the microscope will be 7/6 of the actual depth bored. If, now, *m* be rotated until the micrometer scale stands at right angles to the beam, and be then tipped gently, an inclination may be found where, under a high power, only one line of the micrometer scale is in focus at a time, and a downward focus of precisely .01^{mm} or 10 microns (micromillimeters) is necessary to bring the next lower line on the slope into focus. Conversely, if we focus on the lower line and allow the diamond to bore its way down 10 μ , the next higher line of the micrometer glass will come into sharp focus only when that depth is reached. We thus have here an extremely sensitive measure of depth.

Method of using the apparatus.—The standard is first adjusted to the microscope foot, so that the diamond is exactly 10^{mm} from the center of the stage (cross-hairs) as recorded on the stage micrometer scale movement. The preparation is fixed in the angle piece and clips on the stage. The beam being in perfect balance, it is locked: record is made of the readings of *i*, *i*₁ and *R*. Equal weights are placed on each pan. The mineral is centered to the cross-hairs of the microscope, and a part of the mineral surface is selected for the test under the low power, No. 2, whose long focus prevents the objective from striking *m*. By the stage movement the mineral is pushed 10^{mm}, when it is exactly under the diamond. The latter is lowered to the mineral surface until slight contact is indicated by the movement of the indicator hand: it is checked exactly at the point of contact—if anything a little above it. The lock, *L*, is released so that the diamond is actually resting on the mineral, and the micrometer scale, *m*, is focussed under objective (No. 7) of the microscope, so that the lowermost of two lines near the center of the field are in focus, with the inclination arranged 10 μ to the scale division: ocular No. 3 is most effectual, giving considerable spherical aberration which

allows only the one line to be in sharp focus at a time. L is locked, and the rotation started with the clockwork at a uniform speed. L is released, and the diamond begins to bore. The uniformity of the rate is indicated by the movement of the index hand, i : care must be taken to note the initial position of i , and to keep record of the number of times it makes a complete revolution. The micrometer focus is watched carefully in the microscope and when the upper line appears sharp the lock is closed and the clockwork then checked. In this way the diamond is moving at a uniform rate when it begins to bore and when checked. i and i_1 now give the hardness in terms of rotations of the diamond.

The accessory parts of the apparatus are a levelling table of seasoned mahogany for the microscope with a sunk spirit level and three levelling screws, and the clockwork, which is attached to the levelling table by an adjustable slide for regulating the belt tension.

The adjustments necessary prior to experiment are :

Levelling table,
 Adjusting tension of belts,
 " " pivots,
 " lock,
 " foot-screws,
 " counterpoises,
 " inclination of micrometer,
 Centering diamond.

The diamond is centered by inverting the apparatus and holding it in a vise so that the diamond is turned upward in the field of the microscope. With a jeweler's screw-driver the three radial screws of the chuck may be so adjusted that the extreme tip of the diamond rotates on the cross-hairs of the ocular without eccentricity: or, if it is desirable that the diamond move in a circular path, and so describe a ring-shaped scratch, it may be so adjusted.

Calibration and Measurement.

The instrument is calibrated by testing the constancy of each element, viz: depth, rate, the diamond point and weight. Tests with various weights show that the action of the diamond is slow, and moreover, there is a very rapid increment of resistance with increased depth. A weight of 10^{gm} , rate 10 revolutions per second, gave the value for an ordinary cover-glass of about three thousand revolutions for a depth of $\cdot 01^{\text{mm}}$. Thus the test occupied about five minutes. The increment of resistance implies increment of surface of abrasion. The constancy

of this increment for different diamond points is now being investigated. In a future publication the calibration of the instrument will be described in detail; in the present work we shall describe only a preliminary series of tests with the minerals of the Mohs scale, in order to show the efficacy of the method.

The Mohs scale; sclerometric values.—For these tests the diamond point was adjusted slightly out of center, so that it would abrade away a perfect ring-shaped groove and thus avoid the clogging of the hole noticed in Pfaff's experiments. The micrometer scale m was arranged parallel to a cross-hair set in the 45° position from lower left quadrant to upper right, and the inclination of the scale was adjusted so that the two scale divisions nearest the center of the cross-hairs should record a difference of focal depth of 10μ . It is important that these focal measurements be read always on the same part of the field of the ocular, as there is considerable variation in different parts due to aberration. It is also necessary to adopt a uniform criterion of focal perfection; for the author a fine granular structure observed in the micrometer glass at the side of each scale division afforded a very sharp determinant, accurate in every case to a fraction of the value $.001^{\text{mm}}$ or 1μ . The rate adopted for this series of tests was 6–7 revolutions of the diamond per second, regulated by the governor on the clockwork and by the tension of the belts; this was checked at various times throughout the series and was found to maintain a very uniform average; the clockwork was wound up to its maximum tension at the beginning of each test, and in the case of the harder minerals at the end of every ten minutes, this being determined as the period through which the main-spring would maintain a uniform rate without appreciable change. The weight used was ten grams, which was found too high for the soft minerals and too low for the very hard ones, showing the advisability of using two sets and reducing to a common unit as in Pfaff's tests: the constant weight was retained, however, in the following series, in order to discover the possibilities of the instrument, and no great value is placed upon these preliminary results. Many inaccuracies will be discovered in the results attained, especially in the case of the soft minerals, which are averaged in each case from three observations, and these show considerable diversity for the same mineral, depending upon variations in surface texture, and irregularities in the rotation induced by too great weight and irregular resistance, as will be mentioned. The indices i and i_1 were read before each test and the number of complete revolutions of i_1 was recorded during the experiment. A preliminary test with soft glass showed the radius of eccen-

tricity of the diamond point to be $\cdot 08^{\text{mm}}$, with the filings most abundantly heaped outside the periphery of the ring, and a smaller ridge within.

2. GYPSUM. Cleavage.
 Weight 10 gm.
 Depth 10μ
 Rate 6.5 rev. per sec.
 Hardness (revolutions) 8.3.

Under such weight the diamond penetrated to the glass under the first thin section used almost instantly: a cleavage fragment was tried, and the above value is an average of borings to several different depths, it being found impossible to stop the boring at exactly 10μ depth, so great was the oscillation of the scale m in the field of the microscope: this was caused by the eccentricity of the diamond, the point penetrating too rapidly and meeting unequal resistances in different cleavage directions. This difficulty was less noticeable in the hard minerals.

3. CALCITE. Cleavage face.
 H 50.

In both gypsum and calcite the groove formed was somewhat elliptical, instead of circular. This is due to diverse cohesion values for different cleavage directions as worked out by Exner. The initial variations in resistance force the diamond out of its normally circular path. Three tests on the same calcite face showed these elliptical grooves to be *similarly oriented* with reference to the cleavage fissures, the longer axis of the ellipse occupying an oblique position between the long and short diagonals of the rhomb face. This coincides with the determination by Franz of maximum and minimum hardness in the azimuth of the short diagonal in opposite directions.

4. FLUORITE. Octahedral cleavage.
 H 143.

The depth was checked by direct focal measurement in a series of observations on fluorite, and was found to conform within 0.5μ with the record given by the inclined micrometer m . One groove had sub-elliptical form, with a slight flattening on one side. A series of observations to test the increment of resistance with increased depth gave the following values:

| Depth in μ . | Revolutions. | Rev. for each 5μ . |
|------------------|--------------|------------------------|
| 10 | 148 | 74 |
| 15 | 273 | 125 |
| 20 | 459 | 186 |
| 25 | 666 | 207 |

5. APATITE. Basal.
H 233.

The value is much affected by surface texture. The filings have a very mealy consistency, and seem to have a lubricating action on the work of the abrader; when the abrasion was continued for a second 10μ depth, the increment of resistance was enormous. The groove was elliptical, with the longer axis parallel to the next adjacent prism face.

6. ORTHOCLASE. P Cleavage.
H 4665.

Action very constant, with uniform results for several tests. Ring nearly circular. Oscillation so slight that the micrometer focus could be observed during the rotation. It was found advisable to check the rotation with the clockwork rather than with the lock for occasional precise observation of the location of the sharp focus, as in this way the diamond was not lifted from the groove, but remained at exactly the depth attained.

7. QUARTZ. Basal.
H 7648.

Practically no vibration, very constant.

8. TOPAZ. Basal.
H 28867.

9. CORUNDUM. Rhombohedral cleavage.
H 188808.

With so slight a weight the duration of this test with corundum was nearly nine hours. Hence the advisability of using greater weight with the harder minerals: nearly all the minerals of petrographic importance come into this category. Reducing the foregoing values to the standard adopted by Rosiwal, making corundum equal to 1000, we obtain the following results; the values obtained by Rosiwal and Pfaff are appended for comparison:

| | Pfaff, 1884. | Rosiwal, 1892. | Jaggar, 1897. |
|-------------------------|--------------|----------------|---------------|
| 9. Corundum | 1000 | 1000 | 1000 |
| 8. Topaz | 459 | 138 | 152 |
| 7. Quartz | 254 | 149 | 40 |
| 6. Orthoclase | 191 | 28.7 | 25 |
| 5. Apatite | 53.5 | 6.20 | 1.23 |
| 4. Fluorite | 37.3 | 4.70 | .75 |
| 3. Calcite | 15.3 | 2.68 | .26 |
| 2. Gypsum | 12.03 | .34 | .04 |

In addition to the determination of hardness, the microsclerometer may be used for very delicate determinations of

the thickness of mineral thin-sections; by making contact with the upper surface of a mineral and then with the object glass level at its side we may measure thickness, for the Chaulnes method of determining the index of refraction. Tests with hypersthene suggested further that by boring through a mineral of high double refraction to the glass beneath we may rapidly get a value for the amount of double refraction or $\gamma - a$. The conical depression shows on its border the color rings marking various thicknesses; if we bore to red of the first order, make a depth reading, and then bore through to the glass and read again, the difference in depth gives the thickness of the mineral for red of the first order. If we do this on a section cut in the plane of the optic axes, so that the axis of mean elasticity, b , lies in the plane of polarization of the microscope, we have a thickness value which will give directly, by reference to the calculated tables (v. Rosenbusch) the category to which the mineral belongs. Lastly, the use of this instrument in treating by actual contact the individual minerals of a rock section, suggests the possibility of an adaptation by which perhaps chemical tests may be applied directly to the dust in the boring.

ART. XLIII.—*Recent Observations on European Dinosaurs*;
by O. C. MARSH.

DURING the past summer, it was my privilege to attend the International Congress of Geologists at St. Petersburg, as an official delegate from this country, and this gave me an opportunity to see a number of museums and collections in Europe which I had not before visited. I thus had the privilege of inspecting personally many interesting reptilian remains that I had not previously known, and of examining others which were more or less familiar to me from figures and descriptions.

In the present paper, I have only time to speak of the Dinosaurs, in which I have long taken a special interest, and have endeavored to study all the known specimens of importance, both in this country and in Europe, having in view the preparation of a series of memoirs on the different groups of this subclass of extinct Reptilia.

London.

I began my investigations in the British Museum in London, a great treasure-house for fossil reptiles, to which I have long made frequent pilgrimages. This time the Dinosaurs were seen to better advantage than ever before, but of new or unknown forms I found that few had been added to the collection since my visit two years ago; and I consoled myself with the other extinct Reptilia, and especially with the new fossil birds and mammals from South America.

St. Petersburg.

In St. Petersburg I hoped to find many Dinosaurian remains, as here had been brought together an abundance of fossil treasures from various parts of the Russian Empire, which I knew must contain many forms of this group. In the four principal museums of the city, however, I could find no bones of Dinosaurs on exhibition, nor could I learn from any of the museum authorities that such remains had been recognized among the specimens received, neither could I find any such fossils myself among the debris of the collections, so often a rich repository for new or inconspicuous specimens. This was true, also, of the smaller collections visited, and I was at last forced to admit that here, at least, the Dinosaurs of Russia, like the snakes of Ireland, were conspicuous only by their absence.

* Abstract of Communication made to the National Academy of Sciences, Boston Meeting, November 16th, 1897.

Moscow.

This opinion was not changed by a visit to the rich geological collections of Moscow, which I examined with care; although other fossil vertebrates, including many reptiles, were abundantly represented. I was assured, moreover, by various Russian paleontologists, that in other museums of the empire or in the known localities they had seen no Dinosaurian remains. This vain quest, however, only proves that the discoveries are yet to be made, and I confidently expect them at no distant day, since in almost every other part of the world Dinosauria have already been brought to light. In northern Europe west of Russia, and in North America to the east, these reptiles were especially abundant, and the vast territory intervening must contain numerous Dinosaurs, including many new forms of the group.

Vienna.

In Vienna I knew that my friend Professor Suess had a large collection of Dinosaurs in his museum to show me, and I spent several days there in their investigation. This collection was of special interest to me, as it was from the Gosau fresh-water deposits, which, as a student, years ago, I explored mainly in the expectation of finding Cretaceous mammals; and I was not without hope of still detecting such remains during my present visit, as here were the localities where they were, in my judgment, most likely to be found in Europe. The Dinosaurs I examined were from Neue Welt in this formation, and were of great interest. They had all been studied by Bunzel, Seeley, and others, who had recognized ten or twelve distinct genera and many species among them. I could find, however, not more than a quarter of this number, and among these I found no indications of the *Ceratopsia*, which from the published figures and descriptions I supposed to be represented in this collection. The Dinosaurs with dermal armor which I saw, all pertained to the *Stegosauria*, and two distinct genera among them were more nearly like *Scelidosaurus* of the English Jura, and *Nodosaurus* of the American Cretaceous, than any others with which I am familiar. This collection contained the only Dinosaurian remains I could find in Vienna.

Munich.

I next went to Munich, which, under Professor von Zittel, has become a great center for paleontology. I found that the gem of the collection is still the unique *Compsognathus*, which in several previous visits I had studied with care. A reëxamination impressed me even more with the fact, that this is one of the most perfect and interesting vertebrate fossils yet discovered, and no other example of the genus is known. It was

in this unique specimen that years before I had detected the embryo, and this fossil still affords the only known evidence that Dinosaurs were viviparous. I could find no other Dinosaurian bones of interest in the Munich collection, the new features being mainly numerous fine specimens of *Mosasauria* from America, and some interesting remains of *Hesperornis* and *Baptornis* from the same horizon in Kansas.

I was much pleased to see here the new Jurassic fossils collected by Nansen in 1896, at Cape Flora, in Franz Josef Land. These interesting remains are now under investigation by Dr. J. F. Pompeckj, assistant in the Munich museum. I could detect no vertebrate fossils among them, although various indications favor their presence in this fauna.

Paris.

My limited sojourn in Paris gave me no opportunity for a careful examination of the museums there, but I could learn of no recent additions of Dinosaurian remains since my last visit two years before.

Caen.

I next went to Caen, in Normandy, to see the famous Dinosaur *Poikilopleuron*, so well described by Deslongchamps many years ago. Through the kindness of my friend Professor A. Bigot, I had a good opportunity to study this unique specimen, which of late has been regarded as identical with the *Megalosaurus* of Buckland, the first genus of Dinosaurs described, and one about which little is yet known.

Among the undetermined material of this museum, I was greatly pleased to find the genus *Pleurocaelus* well represented by characteristic fossils, and from a well-defined Jurassic horizon in the vicinity of Havre. The species appears to be a new one, somewhat smaller than *Pleurocaelus suffosus* from the Kimmeridge of Swindon, England. It resembled still more closely *Pleurocaelus nanus*, which I have described from the Potomac formation of Maryland.

Pleurocaelus is one of the most characteristic genera of the Sauropodous *Dinosauria*, and its value in marking a geological horizon should therefore have considerable weight. It is now known from the two European localities mentioned above, both in strata of undoubted Jurassic age. The same genus is well represented in the Potomac deposits of Maryland, and has been found, also, in the Atlantosaurus beds of Wyoming, thus offering, with the associated fossils, strong testimony that the American and European localities are in the same general horizon of the upper Jurassic.

Havre.

The last day at my disposal before sailing for America, I spent in Havre, in the Muséum d'Histoire Naturelle, where the director, M. Lennier, showed me many vertebrate fossils of interest, from the well-known localities near the city. Here again, among the fragmentary specimens not yet investigated, I found the bones of another Dinosaur, also one of the *Sauropoda*, but considerably larger than the *Pleurocelus* at Caen. The remains were very similar to those of *Morosaurus*, and the horizon was in the Kimmeridge, which is here well defined.

From Havre, I crossed the Channel to Southampton, and with a parting look at the Wealden cliffs of the Isle of Wight, which have furnished the remains of so many interesting Dinosaurs, I sailed for home.

Yale University, New Haven, Conn., November 13, 1897.

ART. XLIV—*On the Sapphires from Montana, with special reference to those from Yogo Gulch in Fergus County*; by GEORGE F. KUNZ.

THE existence of sapphires in the State of Montana has been known for some years past, and has attracted considerable attention. Several localities are now known and several distinct modes of occurrence. They were first found in transported gravels along the bars of the Upper Missouri; then they have been found in the earthy product of decomposed dikes, and lastly farther down in the unaltered igneous rock itself; the succession thus presents a close parallel to the history of the diamond-workings in South Africa.

The first published description of the Montana sapphires was by the late Dr. J. Lawrence Smith, in this Journal (III, vol. vi, p. 185, September, 1873). He there said: "These pebbles are found on the Missouri River near its source, about sixty-one miles above Benton; they are obtained from bars on the river, of which there are some four or five within a few miles of each other. Considerable gold is found on these bars, it having been brought down the river and lodged there; and the bars are now being worked for gold. The corundum is scattered through the gravel (which is about five feet deep) upon the rock bed. Occasionally it is found in the gravel and upon the rock bed in the gulches, from forty to fifty feet below the surface, but it is very rare in such localities."

A fuller account of the conditions and yield was given by the author in his volume on "Gems and Precious Stones of North America," published in 1890 (pp. 48, 49); he subsequently visited the locality and examined it carefully, publishing the results in the Appendix to the same work (pp. 340, 342).

In 1891 the first serious attention began to be paid to the mining of sapphires in this district. The bars consist of an auriferous glacial gravel; and in working them for gold, sapphires were obtained as a by-product. By 1890 companies began to be formed and claims taken up and examined with a view to sapphire-mining. The region extends for some six miles along the Missouri River, the central point being Spokane Bar, twelve miles east of the city of Helena. Other names, such as Emerald Bar, Ruby Bar, French Bar, Eldorado Bar, etc., were given to different points of the area. The gravel rests on a slaty bed-rock and the author found minerals besides gold and sapphires; among these are small crystals of white topaz, garnets in rounded grains often of rich

color and miscalled rubies, cyanite, stream-tin, chalcedony, limonite pseudomorphs after pyrite nodules, etc. At Ruby Bar two facts of great significance were encountered, bearing on the age of the gravel and the source of the gems. The writer saw and measured a mastodon tusk three feet long, embedded in the sapphire layer of the gravel; and a dike was found cutting the slaty bed-rock beneath; in this dike were crystals of sapphire, pyrope and sanidin. All these facts were described by the writer in the *Mineralogical Magazine* (vol. ix, p. 396, 1891), together with an account of the rock by H. Miers (loc. cit.), who characterized it as a "vesicular mica-augite-andesite," abounding in brown mica and porphyritic crystals of augite, with a ground-mass of feldspar microlites and brown glassy interstitial matter, with magnetite.

Two years before, indeed, in 1889, the writer had seen some specimens of a trachytic rock, enclosing well-defined crystals of sapphire similar to those of Eldorado Bar, from a dike somewhat farther up the river. These facts, which were referred to in the "*Gems and Precious Stones of North America*" (p. 49), and the Appendix (p. 341), sufficiently showed the source of the gems as coming from the erosion of dikes of igneous rock.

More recently sapphires have been found throughout a considerable district lying some seventy-five to a hundred miles east of the Missouri bars, the principal point being Yogo Gulch, on the Yogo fork of Judith River near its headwaters, in Fergus County, Montana, on the eastern slope of the Little-Belt Mountains. The nearest town is Utica, fifteen miles to the northwest, in the same county. The sapphires occur over a somewhat extended area, which is being explored and laid out in claims. They are imbedded in a yellow earthy material, from which they may be washed out by sluicing, as for gold, the heavy crystals gathering at the bottom. Mr. S. S. Hobson, of Great Falls, Montana, the original discoverer of the gems at Yogo Gulch, states that at that point there are two veins (dikes?) containing sapphires, which have been traced for a distance of seventy-five hundred to eight thousand feet in an east-and-west course, about eight hundred feet apart. One of these is seventy-five feet wide, and consists of a "yellow earth" (i. e. completely decomposed). It has been found that what was supposed to be the end of the "vein" is really a fifty-foot fault, and that the vein can be traced very much farther. In working down to a greater depth, the unaltered igneous rock has been reached, and its full description is given in an accompanying article by Prof. L. V. Pirsson.

These Yogo Gulch sapphires have been referred to by the writer in the 16th and 17th Annual Reports of the U. S. Geo-

logical Survey, in a chapter on The Production of Precious Stones,—especially in No. 17, for 1895, p. 909; they will be further described in No. 18, for 1896.

Other localities are also coming to light in the same State; one of these is at Rock Creek, Granite County, thirty miles from Phillipsburg, where the gems are reported of good blue color, with other tints, and some pale rubies; another is on Cottonwood Creek, eighteen miles from Deer Lodge,—the stones being of varied colors, red, pink, yellow, and occasionally blue; the third has been recently announced in Choteau County.

As regards the gems themselves, marked differences appear in those from the two principal Montana regions. All are of small size, but they differ in crystallization. Those from the Missouri gravels are characterized by the presence of the prismatic faces, with the basal plane, and rarely any of the rhombohedral modifications,—the prevailing forms being hexagonal, either prismatic or so short as to be tabular. A beautiful example of this type is figured in "Gems and Precious Stones of North America" (colored Plate I, fig. C). The specimens from the minor localities have generally a similar type of form. The Yogo Gulch crystals, on the other hand, are largely rhombohedral, with the basal plane more or less present, but the prismatic and pyramidal faces hardly at all. The rhombohedron α , which is prominent in these crystals, as shown in the figures and descriptions of Dr. J. H. Pratt, has the remarkable interest of being new to this species. Other very noticeable features which the writer was the first to observe and point out, are the striations on the basal plane parallel to its intersections with the rhombohedron, and sometimes rising into steps as the oscillation becomes a replacement, as well shown in Dr. Pratt's figures (Figs. 11*a*–14*a*, p. 427), and the singular depressions on the basal plane in other crystals (Figs. 5–10, p. 425), their sides being formed by faces of the inverse rhombohedron, sometimes meeting in a point, and at other times truncated and floored by a basal plane.

We have here two distinct types of crystallization in the same mineral, from the same State, and produced apparently under similar conditions in igneous rocks. It will be extremely interesting to learn, by further exploitation and study, whether these two types bear any fixed or definite relation to the particular variety of eruptive rock in which they occur. The accounts thus far given of the rocks examined seem to suggest such a possibility.

As to the value of the early Montana sapphires in jewelry, it is hardly possible yet to predict how far it may be really important. Much beautiful material has already been obtained,

but little of high value. Those from the Missouri bars had a wide range of color,—light blue, blue-green, green, and pink, of great delicacy and brilliancy, but not the deep shades of blue and red that are in demand for fine jewelry. As semi-precious or “fancy” stones, they have value, however.

The Yogo Gulch-Judith River region is more promising, the colors varying from light blue to quite dark blue, including some of the true “cornflower” tint so much prized in the sapphires of Ceylon. Others incline to amethystine and almost ruby shades. Some of them are “peacock blue” and some dichroic, showing a deeper tint in one direction than in another; and some of the “cornflower” gems are equal to any of the Ceylonese, which they strongly resemble,—more than they do those of Cashmere. Several thousand carats were taken out in 1895, from a preliminary washing of one hundred loads of the “earth;” of these, two hundred carats were of gem quality and yielded, when cut, sixty carats of fine stones worth from \$2 to \$15 a carat. All, however, are small, none having yet been obtained of more than $1\frac{1}{2}$ carats in weight.

Mineralogically, the Montana sapphires possess great interest. The accompanying papers of Prof. Pirsson and Dr. Pratt present the petrological and crystallographic aspects in detail, and to these the reader is further referred.

ART. XLV.—*On the Corundum-bearing Rock from Yogo Gulch, Montana*; by L. V. PIRSSON.

THE corundums whose occurrence and character have been described in the foregoing paper, are found in a dike of igneous rock cutting the sedimentary beds near the entrance of Yogo Gulch. While the corundums, which are washed out as gems, occur in that portion of the dike which has been highly altered and decayed, comparatively little altered material is also obtainable, and the opportunity to study a specimen and some sections cut from it the writer owes to the kindness of Mr. W. H. Weed of the U. S. Geological Survey.

In the hand specimen the rock is of a dark gray, basic appearance and has an uneven fracture. It contains light green or white included fragments which form its most conspicuous feature, and these angular inclusions are probably pieces of limestone broken off and carried upward by the fluid rock in its ascent. They vary in size from those of microscopic dimensions to some that are a centimeter across. Many of them consist entirely of calcite, while others appear to be made up wholly of a pale green mineral which is probably a pyroxene. The largest inclusions show a reaction rim of the same green pyroxene, the rim being about one millimeter thick, while the entire center is of calcite with scattered prisms of the same green pyroxene. The rock itself shows only a few scattered tablets of mica two or three millimeters in diameter as phenocrysts, while the groundmass glitters with minute flecks of biotite, and considerable pyroxene is seen.

It is in this rock that the sapphire occurs imbedded in large, distinct, well-formed crystals as described in the previous paper. They show the corroded, etched surfaces characteristic of this occurrence and often have traces of a blackish crust upon them.

Microscopical. In thin section the rock at once shows its character as a dark, basic lamprophyre, consisting mainly of biotite and pyroxene. There is a little iron ore present, but its amount is small and much less than is usually seen in rocks of this class. The biotite is strongly pleochroic, varying between an almost colorless and a strong, clear, brown tint. It occurs in ragged masses, rarely showing crystal outline, and it contains a large amount of small apatite crystals. The pyroxene is of a pale green tint with the habit of diopside and is filled with many inclusions, now altered but probably originally of glass; in some crystals these inclusions are so abundant as to render the mineral quite spongy. The grains sometimes show crystal form but are mostly anhedral and vary in size, though the evidence is not sufficient to show two distinct generations.

These two minerals lie closely crowded together and no feldspars are seen in the rock. The interstices between them consist of a small amount of a clouded, brownish, kaolin-like aggregate, which appears to represent some former feldspathoid component, possibly leucite, perhaps analcite. The rock appears to have its closest affinities in the monchiquite group, of which it may be considered a basic, somewhat altered type. The abundance of biotite shows its relation to the minettes, but the rock is much richer in the ferro-magnesian components and lacks the feldspar of the minettes. It has evidently a close affinity with the minettes and shonkinite of the region whose occurrence has been already described,* and is clearly a more basic form of the same magma. It has the same richness in biotite and pyroxene as these, but differs in the feldspathic component. The Yogo Peak center is but a small number of miles distant from the locality.

Some calcite in agglomerated granules is also seen in the section and this, as is so often the case in lamprophyres, does not appear as if secondary in origin and is probably due to limestone fragments picked up as previously mentioned.

Origin of the sapphires. The occurrence of such well-crystallized corundum in a basic igneous rock is of great interest. It seems clear, from the many different ways in which this mineral occurs, that there must be several methods in nature for its formation. The association with metamorphic rocks such as gneisses, schists, etc., is well known and its occurrence with granites is also not uncommon. In all these cases, however, the association is with older, metamorphic or granular crystalline rocks, and we know of its occurrence in more recent, undoubted, basic, igneous rocks in but few cases. Lagorio,† in an article to be mentioned presently, gives a list of the known occurrences of corundum in igneous rocks, their tuffs, ejected fragments and contact zones. The number of occurrences where the mineral is found imbedded in igneous rocks is small, and to them the author can add Unkel on the Rhine and Steinheim near Frankfort on the Main, where, as he has observed, small blue sapphires enclosed in the fresh basalt have been found.

By a series of important and interesting experiments Morozewicz‡ showed that molten glass of a basic character dissolved alumina readily and in large quantity, and from this, on cooling, corundum and spinel crystals separated out. Lagorio,§ in commenting on these results and adding details of some experiments of his own, showed that the former idea which had been held concerning the origin of corundum in igneous rocks

* This Journal, vol. 1, 1895, p. 467.

† Zeitschr. für Kryst., vol. xxiv, p. 285, 1895.

‡ Ibid., vol. xxiv, p. 281, 1895.

§ Op. cit., supra.

should now no longer be urged. This idea was that such corundums had been torn loose from some place below where they had previously existed, and being infusible had spread themselves through the magma. Others again recognized in these corundums infusible but recrystallized portions of rock fragments enclosed in the magma, other portions being converted into spinel, cordierite, etc. Lagorio points out, however, that this could not be the case, as corundum dissolves in molten glasses, and he calls attention to the confusion which has existed between *fusibility* of compounds in molten masses and their *solubility* in the same, the two being quite distinct. The characteristic form of corundum occurring with igneous rocks is the thin, flat, hexagonal table with low rhombohedron, described in the following paper.

This occurrence at Yogo Creek is an important addition to the list of pyrogenetic corundum. The clear-cut form of the crystals and their general distribution shows that they have crystallized out of the magma with as much certainty as the well formed phenocrysts of feldspar in a porphyry betray their origin.

The general character of the rock, however, and its close relationship to the minettes and shonkinite of the region shows that it could not originally have been sufficiently rich in alumina to have allowed a general separation out of corundum. The condition of it, as mentioned above, shows that the magma took up great quantities of inclusions from the sediments through which it passed. Among these sediments must have been a great, though unknown, thickness of the Belt formation, consisting of clay shales. This formation lies between the Archæan gneisses and the lowest beds of recognized Cambrian. The liability of the beds to be shattered by igneous rocks ascending through it and included as fragments, has already been shown elsewhere.*

Such included fragments of shale, if the magma maintained its heat sufficiently, as confined in dike form it naturally would do, would eventually be dissolved, as the experiments described show. There would thus be formed local areas in the magma very rich in alumina, which, on cooling, would allow crystals of corundum to separate out. This explanation seems to us most in accord both with the facts observed in the field and those obtained by experiment in the laboratory. The form of the crystals is also in accord with that of the pyrogenetic corundums.

This occurrence then agrees well with the experiments and views of Lagorio and is indeed an important confirmation of them.

Mineralogical Petrographical Laboratory, Sheffield Scientific School, Yale University, New Haven, June, 1897.

* Geology of Castle Mt., Bull. 139, U. S. Geol. Survey, p. 72.

ART. XLVI.—*On the Crystallography of the Montana Sapphires*; by J. H. PRATT.

THE sapphire crystals from Yogo Gulch, Montana, are etched and striated to such a degree that no crystallographic measurements were possible on the reflecting goniometer; but sufficiently accurate angles could be obtained with the contact goniometer to allow of the identification of the faces.

The prism of the second order $a(11\bar{2}0)$ which is so common on corundum was not observed on any of the crystals from this locality. The only two faces that could be identified were the base $c(0001)$ and the rhombohedron $\alpha(30\bar{3}2)$ which is a new face for corundum. On one crystal, two very small faces were observed, which were too small to be measured with the contact goniometer, but were probably the faces of a pyramid of the second order.

In determining the rhombohedron, ten or more independent measurements were made of $c \wedge \alpha$. These varied from 66° to 68° , but approximated closely to 67° , which agrees very well with the calculated value, $67^\circ 3'$, for $0001 \wedge 30\bar{3}2$.

The crystals are developed as shown in figs. 1, 2 and 3, page 425, the prevailing type being like fig. 3. The crystals vary from those where the base is very largely developed, having a diameter of 8^{mm} , while the rhombohedron is only 1^{mm} , to those that have the base and rhombohedron equally developed. (Fig. 1). Where the faces are more equally developed, the rhombohedral faces are generally rounded.

The basal plane often shows characteristic striations which are parallel to the three intersections of the base c , and the rhombohedron α , as shown in fig. 4. These lines are sharp and distinct and on the very flat crystals can easily be measured, when examined under the microscope. The rhombohedral faces are very roughly striated without showing any distinct parallel lines.

One very common development of these crystals is a repeated growth on the basal plane, of the rhombohedron $\alpha(30\bar{3}2)$ and the base, $c(0001)$, as represented in fig. 2. These growths are very varied, as is shown in figs. 11–14 (p.427), where they are drawn in basal projection. In fig. 11, there is but one secondary rhombohedron and base, which has one of its rhombohedron faces a continuation of one of the rhombohedron faces of the crystal. Fig. 12 represents a repeated growth, each face of which is entirely distinct from the faces of the main crystal. In fig. 13 there are represented two and in fig. 14 a series of such growths, where a number of the rhombohedral faces coincide.

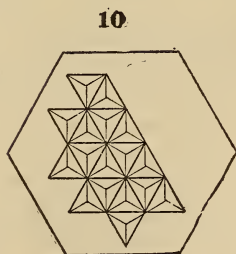
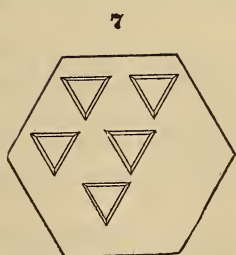
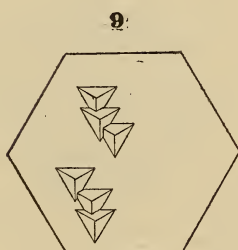
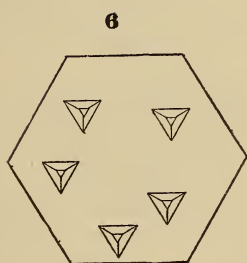
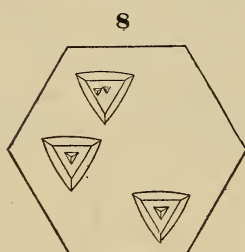
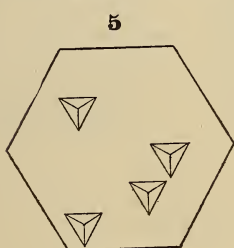
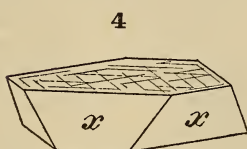
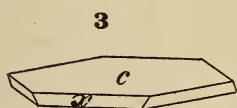
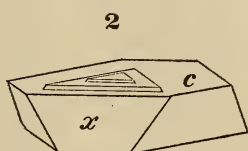
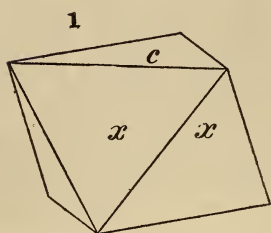

These growths occur most frequently on the flat crystals. The thickness of the rhombohedron rarely reaches 1^{mm} and often they are so thin, that they appear like striations. Figs. 11a-14a, representing the same crystals as figs. 11-14, have been drawn as they appear under the lens, which brings out the relation of the base and rhombohedron to better advantage.

Bauer* in a recent article, entitled "Ueber das Vorkommen der Rubine in Birma," has described this same style of development as occurring on the Burma rubies, but it is not so general as on the Montana corundums.

Etching-figures.—The etching-figures, which were observed on nearly all the crystals examined, were on the basal plane. The figures are very perfect, and although showing many different forms, they all have a rhombohedral symmetry. Fig. 5 represents the common etching-figure, which is a rhombohedral depression terminating in a point. The edges of the depression are sharp and well-defined, as are also the intersections of the rhombohedral faces of the depression. These rhombohedral faces were smooth and gave fair reflections of the signal on the reflecting goniometer. In measuring them, all the crystal but the depression to be measured was covered with a thin coating of wax. Two different crystals were measured, which gave for rhombohedron on rhombohedron 22° 30'; this corresponds to the rhombohedron 10 $\bar{1}$ 7, for which the calculated value is 21° 50'. The same style of figures were observed whose edges were parallel to those of the negative rhombohedron; these, however, are not common in isolated figures.

Another common form is represented in figs. 6 and 7, where the depression is bounded by the basal plane, which at times is so large that the rhombohedral plane is hardly visible. Fig. 8 represents etching-figures, where, on the basal plane of a shallow depression, there is another and sometimes two other etching-figures. These second etching-figures are like the common ones shown in fig. 5. The outer rhombohedral contour of these figures is generally rounded; this is also usually the case with the deeper depressions.

Often the etching-figures are intergrown (fig. 9) and when many of these occur together they have the appearance of raised figures, rather than of depressions. This raised appearance is very striking, when there is a combination of the plus and minus rhombohedron in parallel position and without overlapping each other (fig. 10).

The figures vary considerably in size, but most of them are near 1^{mm} in diameter. A few were observed that were nearly 2^{mm} in diameter.

* Neues Jahrbuch für Min. Geol. und Pal., ii, p. 209, 1896.

11

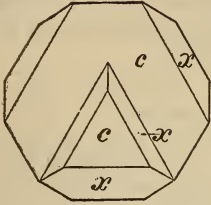

12

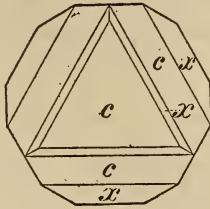

13

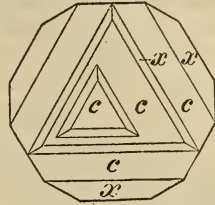

11a



12a



13a



14

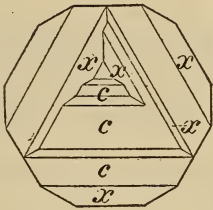

14a



15

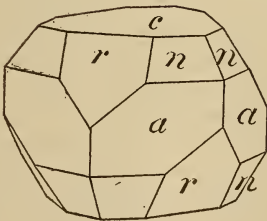

16

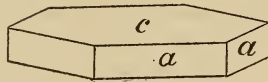

17

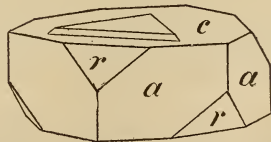

Bauer* has described etching-figures that he observed on the base 0001 and the pyramid 2243 of the Burma rubies. Those on the base are similar to the figures in fig. 5, except that the outside contour of the rhombohedron is rounded.

Sapphires from Emerald Bar, Montana.

The crystals from Emerald Bar, Cañon Ferry, Meagher Co., Montana, are entirely different in their development from those from Yogo Gulch. The prism $a(11\bar{2}0)$ is always present and is usually in combination with the base $c(0001)$ and the unit rhombohedron, $r(10\bar{1}1)$, fig. 17. On some of the crystals, however, the rhombohedron is wanting and the prism is very short as represented in fig. 16. Fig. 15 represents a crystal terminated by a pyramid of the second order in addition to the base and rhombohedron. The measured angles only approximate to the calculated ones for the face 2243, but as this is the common pyramid for corundum it seems very probable that it is the face. The crystal was only well terminated at one end. The crystal is similar to one figured by Bauer from the Burma district.

The crystals are all rough and more or less striated, so that the measurements with the contact goniometer were only approximate, but were sufficiently accurate to identify the faces.

The repeated growth described above was also observed on the Emerald Bar crystals but not in any variety of forms. Only one form of growth was observed, represented in fig. 17, page 427, which is a combination of the unit rhombohedron and the base.

None of the etching-figures so common on the Yogo Gulch crystals were found on these crystals.

Mineralogical Petrographical Laboratory,
Sheffield Scientific School, New Haven, Conn.

* L. c., p. 213.

ART. XLVII.—*Electrical Measurement by Alternating Currents*; by HENRY A. ROWLAND.

THE electrical quantities pertaining to an electric current which it is usually necessary to measure, outside of current, electromotive force, watts, etc., are resistances, self and mutual inductances and capacities. I propose to treat of the measurement of alternating currents, electromotive force and watts in a separate paper. Resistances are ordinarily best dealt with by continuous currents, except liquid resistances. I propose to treat in this paper, however, mainly of inductances, self and mutual, and of capacities together with their ratios and values in absolute measure as obtained by alternating currents. I also give a few methods of resistance measurement more accurate than usually given by means of telephones or electro-dynamometers as usually used and specially suitable for resistances of electrolytic liquids.

I have introduced many new and some old methods, depending upon making the whole current through a given branch circuit equal to zero. These always require two adjustments and they must often be made simultaneously. However, some of them admit of the adjustments being made independently of each other, and these, of course, are the most convenient. But all these zero methods do not admit of any great accuracy unless very heavy currents are passed through the resistances. The reason of this is that an electro-dynamometer cannot be made nearly as sensitive for small currents as a magnetic galvanometer. The deflection of an electro-dynamometer is as the square of the current. To make it doubly sensitive requires double the number of turns in *both* the coils. Hence we quickly reach a limit of sensitiveness. It is easy to measure an alternating current of .0001 ampere and difficult for .00001 ampere. A telephone is more sensitive and an instrument made by suspending a piece of soft iron at an angle of 45° , as invented by Lord Rayleigh, is also probably more sensitive.

For this reason I have introduced here many new methods, depending upon adjusting two currents to a phase-difference of 90° which I believe to be a new principle. This I do by passing one current through the fixed and the other through the suspended coil of an electro-dynamometer. By this means a heavy current can be passed through the fixed coils and a minute current through the movable coil, thus multiplying the sensitiveness possibly 1000 times over the zero current method.

I have also found that many of the methods become very simple if we use mutual inductances made of wires twisted

together and wound into coils. In this way the self inductances of the coils are all practically equal and the mutual inductances of pairs of coils also equal. Hence we have only to measure the minute difference of these two to reduce the constants of the coil to one constant, and yet by proper connections we can vary the inductances in many ratios. Three wires is a good number to use. However, the electrostatic induction between the wires must be carefully allowed for or corrected if much greater accuracy than $\frac{1}{100}$ is desired.

By these various methods the measurement of capacities and inductances has been made as easy as the measurement of resistances, while the accuracy has been vastly improved and many sources of error suggested.

Relative results are more accurate than absolute as the period of an alternating current is difficult to determine, and its wave form may depart from a true sine curve.

Let self inductances, mutual inductances, capacities and resistances be designated by L or l , M or m , C or c , and R or r with the same suffixes when they apply to the same circuit, the mutual inductance having two suffixes. Let b be 2π times the number of complete periods per second, or $b = 2\pi n$.

The quantities bL , bM or $\frac{1}{bC}$ are of the dimensions of resistance and thus $\frac{L}{M}$, b^2LC or b^2MC have no dimensions. b^2LM , $\frac{L}{C}$ or $\frac{M}{C}$ have dimensions of the square of resistances.

Where we have a mutual inductance M_{12} , we have also the two self inductances of the coils L_1 and L_2 . When these coils are joined in the two possible manners, the self inductance of the whole is

$$L_1 + L_2 + 2M_{12} \text{ or } L_1 + L_2 - 2M_{12}.$$

In case of a twisted wire coil the last is very small. Likewise $L_1L_2 - M_{12}^2$ will be very small for a twisted wire coil, as is found by multiplying the first two equations together.

If there are more coils we can write similar equations. For three coils we have

$$L_1 + L_2 + L_3 + 2M_{12} + 2M_{13} + 2M_{23}$$

1. $L_1 + L_2 + L_3 - 2M_{12} - 2M_{13} + 2M_{23}$
2. $L_1 + L_2 + L_3 - 2M_{12} + 2M_{13} - 2M_{23}$
3. $L_1 + L_2 + L_3 + 2M_{12} - 2M_{13} - 2M_{23}$

Connecting them in pairs, we have the self inductances

$$\begin{array}{lll} L_1 + L_2 + 2M_{12} & L_1 + L_3 + 2M_{13} & L_2 + L_3 + 2M_{23} \\ L_1 + L_2 - 2M_{12} & L_1 + L_3 - 2M_{13} & L_2 + L_3 - 2M_{23} \end{array}$$

There are many advantages in twisting the wires of the standard inductance together, but it certainly increases the

electrostatic action between the coils. This latter source of error must be constantly in mind, however, and, for great accuracy, calculated and corrected for. But by proper choice of method we may sometimes eliminate it.

For the most accurate standards, I do not recommend the use of twisted wire coils, at least without great caution. But for many purposes it certainly is a great convenience, especially where only an accuracy of one per cent is desired. In some calculations I have made, I have obtained corrections of from one to one-tenth per cent from this cause.

For twisted wires the above results reduce to $3L+6M$, $3L-2M$. Similar equations can be obtained for a larger number of wires. For twisted wire coils, n wires joined abreast, the self induction is $\frac{L+(n-1)M}{n}$, which is practically equal to L or M . The resistance is R/n .

When we have $n = p+m$ wires twisted and wound in a coil and we connect them p direct and m reverse, the resistance and self induction will be

$$\frac{nR^3 + b^2R[AC + BC - nAB]}{(nR)^2 + (bC)^2} \quad \text{and} \quad \frac{R^2[n(A+B) - C] + b^2ABC}{(nR)^2 + (bC)^2}$$

where R is the resistance of one coil and

$$\begin{aligned} A &= L + (n-1)M \\ B &= L - M \\ C &= nL + (4mp - n)M \end{aligned}$$

This gives self inductances and resistances equal or less than L and R . The correction for electrostatic induction remains to be put in. For the general case, the equation is very complicated for coils abreast, with mutual inductances.

The number of mutual inductances to be obtained is M for two wires, $0, M, 2M$ for three wires, $0, M, 2M, 3M$ for four wires, etc. From these results we see that we are always able to reduce mutual to self inductance. Measuring the self inductance of a coil connected in different ways, we can always determine the mutual inductances in terms of the self inductances.

Thus we need not search for methods of directly comparing mutual inductances with each other, although I have given two of these, but we can content ourselves with measuring self inductances and capacities. Fortunately most of the methods are specially adapted to the latter, the ratio of self inductance to capacity being capable of great exactness by many methods.

In the use of condensers I have met with great difficulty from the presence of electric absorption. I have found that this can be represented by a resistance placed in the circuit of the condenser, which resistance is a function of current period

I have developed Maxwell's theory of electric absorption in this manner. Correcting his equations for a small error, I have developed the resistance and capacity of a condenser as follows:

Let a condenser be made of strata of thicknesses $a_1, a_2,$ etc. and specific induction capacities $k_1, k_2,$ etc. and resistances $p_1, p_2,$ etc. Then we have

$$R = \frac{B_0}{b^2} - \frac{B_2}{b^4} + \frac{B_4}{b^6} - \text{etc.}$$

$$\frac{1}{C} = A_0 - \frac{A_2}{b^2} + \frac{A_4}{b^4} - \text{etc.}$$

Where

$$B_0 = \frac{a_1}{r_1 k_1^2} + \frac{a_2}{r_2 k_2^2} + \text{etc.}$$

$$B_2 = (4\pi)^2 \left\{ \frac{a_1}{r_1^3 k_1^4} + \frac{a_2}{r_2^3 k_2^4} + \text{etc.} \right\}$$

$$B_4 = (4\pi)^4 \left\{ \frac{a_1}{r_1^5 k_1^6} + \text{etc.} \right\}$$

etc.

$$A_0 = 4\pi \left\{ \frac{a_1}{k_1} + \frac{a_2}{k_2} + \text{etc.} \right\}$$

$$A_2 = (4\pi)^3 \left\{ \frac{a_1}{r_1^2 k_1^3} + \frac{a_2}{r_2^2 k_2^3} + \text{etc.} \right\}$$

etc.

Mr. Penniman has experimented in the Johns Hopkins University laboratory with condensers by method 25 and found some interesting results. With a mica standard condenser of $\frac{1}{3}$ microfarad he was not able to detect any electric absorption, although I have no doubt one of the more accurate methods will show it.

With a condenser, probably of waxed paper, he found

| Number of complete periods per second. | Capacity in microfarads. | Apparent resistance in ohms. |
|--|--------------------------|------------------------------|
| 14.0 | 4.64 | 139.6 |
| 32.0 | 4.96 | 34.1 |
| 53.3 | 4.96 | 20.5 |
| 131.1 | 4.94 | 5.2 |

The first value of the capacity seems to be in error, possibly one of calculation. However, the result seems to show a nearly constant capacity but a resistance increasing rapidly with decrease of period, as Maxwell's formulæ shows. The constant value of the capacity remains to be explained.

Mr. Penniman will continue the investigation with other condensers, liquid and solid, as well as plates in electrolytic liquids.

The results in the other measurements have been fairly satisfactory, but many of the better methods have only been recently discovered and are thus untried. But we must acknowledge at once that work of the nature here described is most liable to error. Every alternating current has, not only its fundamental period, but also its harmonics, so that very accurate absolute values are almost impossible to be obtained without great care. To eliminate them, I propose to use an arrangement of two parallel circuits, one containing a condenser and the other a self-inductance, each with very little resistance. The long period waves will pass through the second side and the short ones through the condenser side. By shunting off some of the current from the second side, it will be more free from harmonics than the first one.

However, in a multipolar dynamo, especially one containing iron, there is danger of long period waves also, which this method might intensify. A second arrangement, using the condenser side, might eliminate them. However, many dynamos without iron and without too many poles and properly wound produce a very good curve without harmonics, especially if the resistance in the circuit is replaced by a self inductance having no iron. These remarks apply only to absolute determinations. Ratios of inductance, self and mutual, and capacity are independent of the period, and thus it can always be eliminated. Measurements of resistances also are independent.

But there are other errors which one who has worked with continuous currents may fall into. Nearly all alternating currents generate electromagnetic waves which are so strong that currents exist in every closed circuit with any opening between conductors in the vicinity.

We eliminate this source of error by twisting wires together and other expedients. But in avoiding one error, we plunge into another. For, by twisting wires we introduce electrostatic capacity between them, which may vitiate our results. Thus, in methods 23 or 24 for comparing mutual inductances, if there is electrostatic capacity between the wires, a current will flow through the electro-dynamometer in the testing circuit and destroy the balance.

Various expedients suggest themselves to eliminate this trouble, as, for instance, the variation of the resistance A in the above, but I shall reserve them for a future paper. I may say, however, that it is sometimes possible, as in method 12 for instance, to choose a method in which the error does not exist.

However, with the best of methods, much rests with the experimenter, as errors from electromagnetic and electrostatic induction are added to errors from defective insulation when we use alternating currents.

These errors are generally less than one per cent, however, and intelligent and careful work reduces them to less than this.

The following methods generally refer by number to the plate on which the resistances, etc. are generally marked. One large circle with a small one inside represent an electro-dynamometer. Of course the circuit of the small coil can be interchanged with the large one. Generally we make the smaller current go through the hanging coil.

By the methods 1 to 14, we adjust the electro-dynamometer to zero by making the phase difference in the two coils 90° . For greatest sensitiveness, the currents through the two coils must be the greatest possible, heating being the limit. This current should be first calculated from the impedance of the circuit, as there is danger of making it too great.

In the second series of methods, 15–26, the branch circuit in which the current is to be 0 is indicated by 0.

Resistances in the separate circuits are represented by R R' R , etc. and r r' r , etc. Corresponding self inductances and capacities in the same circuits are L L' L , etc. and l l' l , etc. or C C' C , etc. and c c' c , etc. $b=2\pi n$ where n is the number of complete current waves per second.

The currents must be as heavy as possible, $\frac{1}{10}$ ampere or more, and it is well to make those that require a current of more than $\frac{1}{100}$ ampere of larger wire freely suspended in oil. A larger current can, however, be passed through an ordinary resistance box for a second or two without danger. A few fixed coarse resistances of large wire in air or oil with ordinary resistance boxes for fine adjustment, are generally all that are required. Special boxes avoiding electrostatic induction are, however, the best, but are not now generally obtainable.

In some methods, such as 8, 9, 10, etc. we can eliminate undesirable terms containing the current period by using a key which suddenly changes the connections before the period has time to change much.

In using twisted wire mutual inductances, methods 7 and 12 are about or entirely free from error due to electrostatic action between the wires. In all the methods this error is less when the resistance of the coils is least and in 23 and 24 when A is least. In method 8 the error is very small when the coil resistances and R are small and r great. In this method with 1 henry and 1 microfarad the error need not exceed 1 in 1000. Probably the same remarks apply to 9, 10, 11, also. By suitable adjustment of resistances in the other method, the error

may be reduced to a minimum. It can, of course, be calculated and corrected for.

An electro-dynamometer can be made to detect .0001 ampere without making the self inductance of the suspended coil more than .0007 henrys or that of the stationary coils more than .0006 henrys, the latter coil readily sustaining a current of $\frac{1}{10}$ amperes without much heating.

An error may creep in by methods 1-14 if the current through the suspension is too great, thus heating it and possibly twisting it. This should be tested by short circuiting the suspended coil or varying the current. For the zero method it is eliminated by always adjusting until there is no motion on reversing the current through one coil.

Inductances containing iron introduce harmonics and vary with current strength. Thus they have no fixed value.

Closed circuits or masses of metal near a self inductance, diminish it, and increase the apparent resistance which effects vary with the period. Short circuits in coils are thus detected.

Electrolytic cells act as capacities which, as well as the apparent resistance, vary with the current period. They also introduce harmonics. The same may be said of an electric arc.

An incandescent lamp or hot wire introduces harmonics into the circuit.

Hysteresis in an iron inductance acts as an apparent resistance in the wire almost independent of the current period, and does not, of itself, introduce harmonics. The harmonics are due to the variation of the magnetic permeability with the amount of magnetization.

Electric absorption in a condenser acts as a resistance varying with the square of the period, the capacity also varying, as I have shown above.

In general any circuit containing resistances, inductances and capacities combined acts as a resistance and inductance or capacity, both of which vary with the current period, the square of the current period alone entering. For symmetry the square of the current period can alone enter in all these cases and those above.

Hence only inductances containing no iron or not near any closed metallic circuits have a fixed value. The same may be said of condensers, as they must be free from electric absorption or electrolytic action to have constants independent of the period. There is no apparent hysteresis in condensers and the constants do not apparently vary with the electrostatic force.

The following numbers indicate both the number of the method and the figures in the plate, p. 437.

Method 1.

$$\frac{L'}{c} = \frac{[r(\mathbf{R}_i + \mathbf{R}'') + \mathbf{R}_{ii}(r + \mathbf{R}_i)] [\mathbf{R}'(\mathbf{R}_i + \mathbf{R}_{ii}) + \mathbf{R}''(\mathbf{R}_i + \mathbf{R}')] }{(\mathbf{R}_i + \mathbf{R}'' + \mathbf{R}_{ii})^2}$$

Method 2.

$$\frac{L'}{c} \text{ or } b^2 L L' \text{ or } -\frac{1}{b^2 c c'} = \frac{[\mathbf{R}_{ii} \mathbf{R}' - \mathbf{R}_i \mathbf{R}''] [\mathbf{R}_i (r + \mathbf{R}') + \mathbf{R}_{ii} (r + \mathbf{R}_i)]}{\mathbf{R}_{ii} (\mathbf{R}_i + \mathbf{R}_{ii})}$$

Method 3.

In (1) make $\mathbf{R}' = \mathbf{R}'' = \mathbf{R}_{ii} = 0$ or in (2) make $\mathbf{R}'' = \mathbf{R}_i = 0$
 $\mathbf{R}_{ii} = \infty, \frac{L'}{c} = r \mathbf{R}'$

In case the circuit r contains some self inductance, l , we can correct for it by the equation

$$\frac{L'}{c} = r \mathbf{R}' \left(1 - \frac{1}{b^2 l c} \right)$$

Method 4.

$$\frac{L_1}{c} = \frac{[\mathbf{R}'(r + \mathbf{R}_{ii}) + \mathbf{R}''(\mathbf{R}' + \mathbf{R}_{ii})][\mathbf{R}'(\mathbf{R}'' + \mathbf{R}_{ii}) + \mathbf{R}''(\mathbf{R}_i + \mathbf{R}_{ii})]}{\mathbf{R}' \mathbf{R}''}$$

Method 5.

$$\frac{L_1}{c} = \frac{[\mathbf{R}_i(\mathbf{R}'' + \mathbf{R}_{ii}) + \mathbf{R}_{ii}(\mathbf{R}' + \mathbf{R}'')][\mathbf{R}'(\mathbf{R}'' + \mathbf{R}_{ii}) + r(\mathbf{R}' + \mathbf{R}'')]}{(\mathbf{R}' + \mathbf{R}'')(\mathbf{R}'' + \mathbf{R}_{ii})}$$

Method 6.

$$\frac{L}{c} \text{ or } \frac{l}{C} = (\mathbf{R} + \mathbf{R}') (\mathbf{R}'' + r)$$

We can correct for self inductions, L', L'' in the circuits $\mathbf{R}', \mathbf{R}''$ by using the exact equation

$$b^2 \left[[L'(r + \mathbf{R}'') + \left(L' - \frac{1}{b^2 c} \right) \mathbf{R}'] \right] \left[L''(\mathbf{R} + \mathbf{R}') + \mathbf{R}''(L + L') \right] + \mathbf{R}' \mathbf{R}'' (r + \mathbf{R}'') (\mathbf{R} + \mathbf{R}')$$

or approximately

$$\frac{L}{c} = (\mathbf{R} + \mathbf{R}') (\mathbf{R}'' + r) - \frac{L'}{c} - \frac{L''}{c} \frac{\mathbf{R} + \mathbf{R}'}{\mathbf{R}''} + b^2 \frac{L [L'(r + \mathbf{R}'') + L'' \mathbf{R}']}{\mathbf{R}'}$$

+ etc.

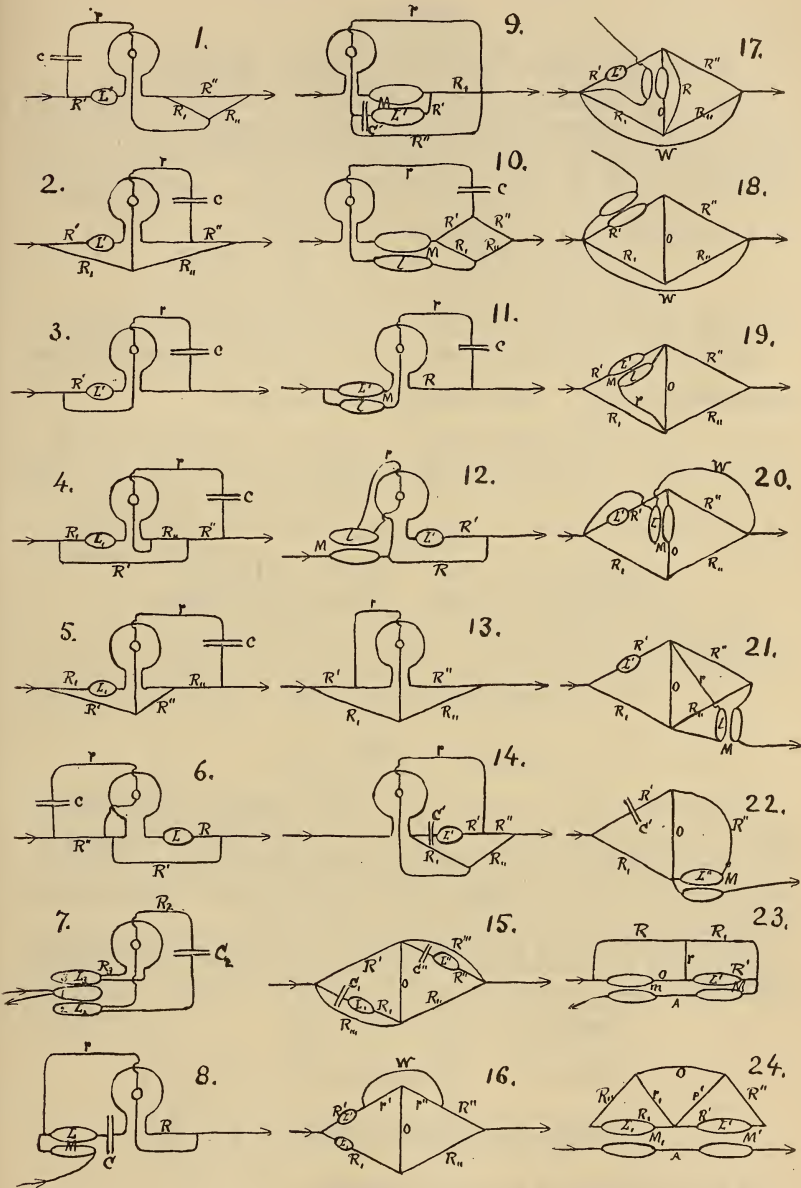

In methods 1 to 14 inclusive the concentric circles are the coils of the electro-dynamometer. Either one is the fixed coil and the other the hanging coil. Oblong figures are inductances and when near each other, are mutual inductances. A pair of cross lines is a condenser.

Method 7.

$$R_2 R_3 M_{12} M_{13} + b^2 [L_3 M_{12} - M_{23} M_{13}] [L_2 M_{13} - M_{23} M_{12}] = 0$$

For a coil containing three twisted wires, $M_{12} = M_{13} = M_{23}$, and the self inductions of the coils are also equal to each other and nearly equal to the mutual inductions. Put an extra self induction L_3 in R_3 and a capacity C_2 in R_2 . Replace L_3 by $L + L_3$ and L_2 by $L - \frac{1}{b^2 C_2}$ and we can write

$$\frac{L_3 + L - M}{C_2} = R_2 R_3 + b^2 (L - M) (L_3 + L - M).$$

As $L - M$ is very small and can be readily known, the formula will give $\frac{L_3}{C_2}$. When $L - M = 0$ we have

$$\frac{L_2}{C_2} \text{ or } \frac{L_3}{C_2} = R_2 R_3$$

Method 8.

$$\begin{aligned} b^2 M(M + L) &= rR & 2b^2 M^2 &= rR + (rR)' \\ \text{or } b^2 M(M - L) &= (rR)' & 2b^2 LM &= rR - (rR)' \end{aligned}$$

Placing a capacity in the circuit R , we have also

$$\begin{aligned} b^2 M(M + L) - \frac{M}{C} &= rR \\ \text{or } b^2 M(M - L) + \frac{M}{C} &= rR \end{aligned}$$

In case the coil is wound with two or more twisted wires, $M - L$ is small and known. For two wires, $M - L$ is negative. For three wires, two in series against the third, M can be made nearly equal to $2L$. Hence M , L and C can be determined absolutely, or C in terms of M or vice versa.

To correct for the self induction, l , of r we have the exact equations

$$\begin{aligned} b^2 M(M + L) &= rR + b^2 l(L + M) \\ b^2 M(M - L) &= rR + b^2 l(L - M) \\ b^2 M(M + L) - \frac{M}{C} &= rR - b^2 l \left(L + M - \frac{1}{b^2 C} \right) \\ b^2 M(M - L) + \frac{M}{C} &= rR - b^2 l \left(L - M - \frac{1}{b^2 C} \right) \end{aligned}$$

If the condenser is put in r , we have

$$\begin{aligned} \frac{L + M}{c} &= rR - b^2 M(L + M) \\ \text{or } \frac{L - M}{c} &= rR + b^2 M(L - M) \end{aligned}$$

Method 9.

$$b^2L'M - \frac{M}{C'} = R_i \left[R' + R_i + \frac{rR''}{r+R''} \right]$$

$$\text{or } -b^2L'M + \frac{M}{C'} = R_i \left[R' + R_i + \frac{rR''}{r+R''} \right]$$

Making $R'' = \infty$ and $r + R' = r$ we have

$$-b^2L'M + \frac{M}{c'} \text{ or } b^2L'M - \frac{M}{C'} = R_i(r + R_i)$$

Taking two observations we can eliminate $b^2L'M$ and we have

$$\frac{M}{C'} = R_i \{r - (r)'\}$$

Knowing $L'M$ we can find C' . Throwing out C' (i. e., making it ∞) we can find $b^2L'M$ in absolute measure: then put in C' and find its value as above.

To correct for self induction in R_i , we have for case $R'' = \infty$, the exact equation

$$b^2L'M - \frac{M}{C'} = R_i(r + R_i) + b^2[L' + L_i - M]L_i - \frac{L_i}{C'}$$

The correction, therefore, nearly vanishes for two twisted wires in a coil where $L' - M = 0$ and C is taken out.

Method 10.

$$-b^2LM + \frac{M}{c} \text{ or } b^2LM - \frac{M}{c} =$$

$$\frac{[R_iR'' - R_{ii}R']\{r[R' + R'' + R_i + R_{ii}] + (R' + R_i)(R'' + R_{ii})\}}{[R' + R'' + R_i + R_{ii}]^2}$$

This can be used in the same manner as 9 to which it readily reduces. But it is more general and always gives zero deflection when adjusted, however M is connected. To throw out C make it ∞ .

Method 11.

$$\frac{L-M}{c} = rR + b^2(l-M)(L-M)$$

$$\frac{L+M}{c} = rR + b^2(l+M)(L+M)$$

For the upper equation the last term may be made small and the method may be useful for determining $L - M$ when c is known. Method 8, however, is better for this.

Method 12.

$$\frac{L'}{l} = \frac{R+R'}{r}$$

Should the circuits R and r also have small self inductances, L and l , we can use the exact equation

$$L'+L = \frac{R+R'}{r} l \frac{1 + \frac{Lr}{lR}}{1 - \frac{b^2Ll}{rR}} = \frac{R+R'}{r} l \left[1 + \frac{Lr}{lR} + \frac{b^2Ll}{rR} + \text{etc.} \right]$$

When L' and l are approximately known, we can write the following, using the approximate value on the right side of the equation

$$\frac{L'}{l} = \frac{R+R'}{r} \left[1 + \frac{Lr}{lR} - \frac{L'}{l} \frac{r}{R+R'} + \frac{b^2Ll}{rR} + \text{etc.} \right]$$

Taking out L' and putting a condenser, C , in R we have

$$\frac{l}{C} = rR' - b^2lCR(R+R')$$

For a condenser, R can be small or zero.

Method 13.

$$(A) \left[bL'' - \frac{1}{bC''} \right]^2 = \frac{[R_{ii}R' - R'R''] [R_{ii}(r+R_i) + R_i(r+R'')]}{R_i^2}$$

This determines capacities or self inductions in absolute value. As described above, mutual induction can also be determined by converting it into self induction.

$$(B) \left[bL_{ii} - \frac{1}{bC_{ii}} \right]^2 = \frac{[R''R_i - R'R_{ii}] [R_{ii}(r+R_i) + R_i(r+R'')]}{R_i^2(r+R_i)}$$

$$(C) \left[bL_i - \frac{1}{bC_i} \right]^2 = \frac{[R'R_{ii} - R''R_i] [R_i(r+R'') + R_{ii}(r+R_i)]}{R_{ii}^2[r+R''+R_{ii}]}$$

Method 14.

$$bL' - \frac{1}{bC'} \Bigg]^2 = \frac{[R_iR'' - R_{ii}R'] [r[R' + R_i + R'' + R_{ii}] + [R' + R_i] [R'' + R_{ii}]]}{R_{ii}^2[r+R''+R_{ii}]}$$

Of course, in any of these equations, methods 13 or 14, L'' is eliminated by making $L'' = 0$ or the condenser, C , is omitted by making $C = \infty$.

Method 15.

$$-\frac{1}{b^2 C_i C''} \text{ or } b^2 L_i L'' \text{ or } -\frac{L_i}{C''} =$$

$$\frac{R' R_{ii} (R_i + R_{iii}) (R'' + R''') - R'' R_i R''' R_{iii}}{R' R_{ii} - R''' R_{iii}}$$

$$\frac{C''}{C_i} \text{ or } \frac{L_i}{L''} \text{ or } -b^2 L_i C'' = \frac{R_{iii} R''' R_i - R' R_{ii} (R_i + R_{iii})}{R' R_{ii} (R'' + R''') - R'' R_i R''' R_{iii}}$$

When $R_{iii} = \infty$ we have

$$\frac{L_i}{C''} = \frac{R' R_{ii} (R'' + R''') - R'' R_i R'''}{R'''} = R' R_{ii} - \frac{R''}{R'''} [R''' R_i - R' R_{ii}]$$

$$b^2 L_i C'' = \frac{R''' R_i - R' R_{ii}}{R'' R'''}$$

If we adjust by continuous current, we shall have $R''' R_i - R' R_{ii} = 0$. For a condenser we can make $R'' = 0$ provided there is no electric absorption. In this case $b^2 L_i C''$ is indeterminate and we can adjust to find $\frac{L_i}{C''}$. However, two simultaneous adjustments are required.

But I have shown that the presence of electric absorption in a condenser causes the same effect as a resistance in its circuit, the resistance, however, varying with the period of the current. Hence R'' must include this resistance. However, the value of R'' will not affect the first adjustment much and so the method is easy to work. If it is sensitive enough it will be useful in measuring the electric absorption of condensers in terms of resistance.

It has the advantage of being practically independent of the current period for $\frac{L}{C}$ as it should be.

For comparison of capacities the same simplification does not occur.

Indeed the method is of very little value in this case, being surpassed by 16.

Method 16.

$$(A) [R_i R'' - R_{ii} R'] [W + r' + r''] + W [R_i r'' - r' R_{ii}] = 0$$

$$\frac{L'}{L_i} \text{ or } \frac{C_i}{C'} = \frac{R''}{R_{ii}} + \frac{(W r'')}{R_{ii} (W + r' + r'')}$$

The first equation is satisfied by adjusting the Wheatstone bridge so as to make

$$(R_i R'' - R_{ii} R') = 0 \quad R_i r'' - R_{ii} r' = 0 \quad R_i (R_{ii} + r'') - R_{ii} (R' + r') = 0$$

That is

$$\frac{R_i}{R_{ii}} = \frac{R'}{R''} = \frac{r'}{r''}$$

We can then adjust W with alternating currents. This is a very good method and easy of application but requires many resistances of known ratio. Many of these, however, may be equal without disadvantage. A well known case is given by making r' and $r'' = 0$.

(B) By placing self inductions or condensers in R_i and r'' instead of the above we have the following

$$\frac{c''}{C'} \text{ or } -b^2 L_i c'' \text{ or } \frac{L_i}{l''} = \frac{R_i(W + R'') - R' R_{ii}}{R''(W + r' + r'') W r''}$$

$$- \frac{1}{b^2 C_i c''} \text{ or } \frac{L_i}{c''} \text{ or } -b^2 L_i l'' =$$

$$\frac{(W'' + r' + r'')(R_i R'' - R_{ii} R') + W(R_i r'' - R_{ii} r'')}{W + R''}$$

Making $R'' = 0$ we have

$$\frac{c''}{C_i} \text{ or } -b^2 L_i c'' \text{ or } \frac{L_i}{l''} = \frac{R_i W - R' R_{ii}}{W r''}$$

$$- \frac{1}{b^2 C_i c''} \text{ or } \frac{L_i}{c''} \text{ or } -b^2 L_i l'' = R' R_{ii} + r' R_{ii} \left(1 + \frac{R'}{W}\right) - \frac{r''}{W}$$

$$(R_i W - R' R_{ii})$$

In case we adjust the bridge to $R_i W - R' R_{ii} = 0$ and a condenser is in r'' so that we can make $r'' = 0$, the value of $-b^2 L_i c''$ will be indeterminate and we can find $\frac{L_i}{c''}$ by the adjustment of W alone.

This is an excellent method, apparently, as only one adjustment is required.

However, see the remarks on method 15. This present method $r'' = 0$ for $\frac{L_i}{c}$ is Anderson's with, however, alternating currents instead of direct as in his.

The other two values are imaginary in this case. Indeed the whole method, B, is only of special value for $\frac{L_i}{c}$, as two adjustments are needed for the others.

Method 17.

(A) $W = \infty$. $R = \infty$

$$b^2 M L' = R_i R'' - R_{ii} R'$$

$$\frac{L'}{M} = \frac{R' + R_i + R'' + R_{ii}}{R_{ii}}$$

By this method the self induction of the mutual induction coil is eliminated. But it is difficult to apply, as two resistances must be adjusted and the adjustment will only hold while the current period remains constant. The same remarks apply to B and C following.

(B) $R = \infty$

$$b^2 ML' = \frac{W[R_1 R'' - R' R_{11}]}{W''' + R_1 + R_{11}}$$

$$\frac{L'}{M} = \frac{W'''[R' + R_1 + R'' + R_{11}] + (R' + R_1)(R'' + R_{11})}{R_{11} W}$$

(C) $W = \infty$

$$b^2 ML' = \frac{R}{R + R'' + R_{11}} (R_1 R'' - R' R_{11})$$

$$\frac{L'}{M} = \frac{R(R' + R_1 + R'' + R_{11}) + (R' + R_1)(R'' + R_{11})}{R R_{11}}$$

Method 18.

$$R_1 R'' - R' R_{11} = 0$$

$$\frac{L'}{M'} = 1 + \frac{R''}{R'} + \frac{R' + R''}{W}$$

L' and M' belong to the same coil. By adjusting the Wheatstone bridge first, W can then be afterwards adjusted.

To find the ratio for any other coil independent of the induction coil, we can first find $\frac{L'}{M'}$ as above. Then add L to the

same circuit and we can find $\frac{L + L'}{M'}$. Whence we can get L .

This seems a convenient method if it is sensitive enough, as the value of $\frac{L'}{M'}$ should be accurately known for the inductance standard.

Method 19.

$$b^2(L'l - M^2) = \frac{r}{R_{11}} [R' R_{11} - R'' R_1]$$

$$\frac{L'}{M} = \frac{R' + R_1}{r} - b^2 \frac{L'l - M^2}{r^2} \left(\frac{l}{M} + 1 \right) = \frac{R' + R_1}{r} - \frac{R' R_{11} - R'' R_1}{r R_{11}} \left(\frac{l}{M} + 1 \right)$$

This is useful in obtaining the constants of an induction standard. For twisted wires $L'l - M^2$ should be nearly 0, depending, as it does, on the magnetic leakage between the coils.

$\frac{l}{M}$ is often known sufficiently nearly for substitution in the right hand member. It can, however, be found by reversing the inductance standard.

Method 20.

$$R'R_{ii} - R''R_i = 0$$

$$\frac{M}{L} = \frac{R''}{R_i + R_{ii}}; \frac{M}{L'} = \frac{W}{R''} \frac{R_{ii}^2}{(R_i + R_{ii})^2}; \frac{L}{L'} = \frac{W}{R' + R''} \quad L > M; \quad L' \text{ any value.}$$

In case of a standard inductance, M and L are known, especially when the wires are twisted.

The method can then be used for determining any other inductance, L' , and is very convenient for the purpose.

R_{ii} and $R_i + R_{ii}$ are first calculated from the inductance standard. The Wheatstone bridge is then adjusted and W varied until a balance is obtained. This balance is independent of the current period, as also in the next two methods.

Method 21.

$$R'R_{ii} - R''R_i = 0$$

$$\frac{l}{M} = \frac{R' + R_i}{R_i}; \frac{L'}{M} = \frac{(R' + R_i)^2}{rR_i}; \frac{L'}{l} = \frac{R' + R_i}{r} \quad l > M.$$

This is Niven's method adapted to alternating currents. See remarks to method 20.

Methods 20 and 21 are specially useful when one wishes to set up an apparatus for measuring self induction, as the resistances R' , R'' , R_i , R_{ii} , can be adjusted once for all in case of a given inductance standard and only W or r need be varied afterwards.

Method 22.

$$\frac{L''}{M} = \frac{R' + R_i}{R_i}; \frac{M}{C'} = R_i R''; \frac{L''}{C'} = R''(R' + R_i)$$

This is Carey Foster's method adapted to alternating currents and changed by making R'' finite instead of zero.

The ratio of $R' + R_i$ to R_i is computed from the known value of the induction standard. R'' is then adjusted and C' obtained. In general the adjustment can be obtained by changing R_i and R'' . The adjustment is independent of the current period.

Method 23.

$$b^2 m L' = r R_i + R[r + R' + R_i]$$

$$\frac{Mr - L'R}{m} = r + R' + R_i$$

If we make $R = 0$ we have

$$b^2 m L' = r R,$$

$$\frac{M}{m} = \frac{r + R' + R_i}{r}$$

This method requires two simultaneous adjustments. M must also be greater than m . As M and L' belong to the same coil, we can consider this method as one for determining m in terms of the M and L' of some standard coil.

The resistance, A , can be varied to test for, or even correct, the error due to electrostatic action between the wires of the induction standard.

Method 24.

$$\frac{L_i}{M_i} = \frac{L'}{M'} \frac{r_i}{r'_i}; \quad \frac{M_i}{M'} = \frac{r'(r_i + R_i + R_{i,i})}{r_i(r' + R' + R'')}$$

This is a good method for comparing standards. We first determine $\frac{L_i}{M_i}$ for each coil by one of the previous methods. Then we can calculate $\frac{r'_i}{r_i}$ and adjust the other resistances to balance.

It is independent of the period of the current and suitable for standards of equal as well as of different values, as the mutual inductances can have any ratio to each other.

For twisted wire coils $r_i = r'_i$ very nearly. See method 23 for the use of the resistance, A .

Method 25.

In fig. 6 remove the shunt R' and self induction L .

This method then depends upon the measurement of the angular deflection when a self induction or a capacity is put in the circuit of the small coil of the electro-dynamometer and comparing this with the deflection, when the circuit only contains resistance.

The resistance of the circuit, r , is supposed to be so great compared with R that the current in the main circuit remains practically unaltered during the change.

There is also an error due to the mutual induction of the electro-dynamometer coils which vanishes when r is great.

$$\frac{1}{b^2 c^2} \text{ or } b^2 l^2 = R'' [r + R''] \left[\frac{r_i + R_{i,i}''}{R_{i,i}''} \frac{\theta_i}{\theta} - \frac{r + R''}{R''} \right]$$

These formulas assume that the deflection is proportional to

θ . This assumption can be obviated by adjusting $\theta = \theta'$ when we have

$$\frac{1}{b^2 c^2} \text{ or } b^2 r^2 = \frac{(r + R'')(r_i R'' - r_i R'')}{R}$$

These can be further simplified by making $R'' = R_i''$.

The method thus becomes very easy to apply and capable of considerable accuracy. As the absolute determination depends on the current period, however, no great accuracy can be expected for absolute values except where this period is known and constant, a condition almost impossible to be obtained. The comparison of condensers or of inductances is, however, independent of the period and can be carried out, however variable the period, by means of a key to make the change instantaneously.

Method 26.

Similar results can be obtained by putting the condenser or inductance in R'' instead of r , but the current through the electro-dynamometer suspension is usually too great in this case unless r is enormous. We have in this case for equal deflections,

$$\frac{1}{b^2 C'^2} \text{ or } b^2 L'^2 = R''(R'' + r) \left(\frac{r_i R_i'' - r_i R''}{r_i R''} \right)$$

Where r_i and R_i'' are the resistances without condenser or self induction.

This is a very good method in many respects.

For using 25 and 26, a key to make instantaneous change of connections is almost necessary.

To measure resistance by alternating currents, a Wheatstone bridge is often used with a telephone.

I propose to increase the sensitiveness of the method by using my method of passing a strong current through the fixed coils of an electro-dynamometer while the weaker testing current goes through the suspended system.

Using non-inductive resistances, methods 10, 13 A, B, C, and 14 all reduce to proper ones. 10 or 14 is specially good and I have no doubt will be of great value for liquid resistances. The liquid resistances must, however, be properly designed to avoid polarization errors. The increase of accuracy over using the electro-dynamometer in the usual manner is of the order of magnitude of 1000 times.

Since writing the above I have tried some of the methods, especially 6 and 12, with much satisfaction. By the method

12, results to 1 in 1000 can be obtained. Replacing L' by an equal coil, the ratio of the two, all other errors being eliminated, can be obtained to 1 in 10,000, or even more accurately.

The main error to be guarded against in method 12, or any other where large inductances or resistances are included, arises from twisting the wires leading to these. The electrostatic action of the leads, or the twisted wire coils of an ordinary resistance box, may cause errors of several per cent. Using short small wire leads far apart, the error becomes very small.

Method 6 is also very accurate, but the electric absorption of the condensers makes much accuracy impossible unless a series of experiments is made to determine the apparent resistance due to this cause.

In method 12 I have not yet detected any error due to twisting the wires of coils l . However, the electrostatic action of twisted wire coils is immense and the warning against their use which I have given above has been well substantiated by experiment. Only in case of low resistances and low inductances or in cases like that just mentioned is it to be tolerated for a moment. Connecting two twisted wires in a coil in series with a resistance between them, I have almost neutralized the self inductance, which was one henry for each coil or four henrys for them in series!

Altogether the results of experiment justify me in claiming that these methods will take a prominent place in electrical measurement especially where fluid resistances, inductances and capacities are to be measured. They also seem to me to settle the question as to standard inductances or capacities, as inductances have a real constant which can now be compared to 1 in 10,000, at least.

The new method of measuring liquid resistances with alternating currents allows a tube of quite pure water a meter long and 6^{mm} diameter having a resistance of 10,000,000 ohms to be determined to 1 in 1,000 or even 1 in 10,000. The current passing through the water is very small, being at least 500 times less than that required when the bridge is used in the ordinary way. Hence polarization scarcely enters at all.

It is to be noted that all the methods 15 to 24 can be modified by passing the main current through one coil of the electro-dynamometer and the branch current through the other. The deflection will then be zero for a more complicated relation than the ones given. If, however, one adjustment is known and made, the method gives the other equation.

Thus method 18 requires $R, R'' - R'R_{\infty} = 0$. Hence, when this is satisfied we must have the other condition alone to be

satisfied. Also in method 22, when we know the ratio of the self and mutual inductances in the coil, the resistances can be adjusted to satisfy one equation while the experiment will give the other and hence the capacity in terms of the inductances.

Again, pass a current whose phase can be varied through one coil of the electro-dynamometer, and the circuit to be tested through the other. Vary the adjustments of resistances until the deflection is zero, however the phase of current through the first coil may be varied.

The best methods to apply the first modification to are 15 A, 16 A and B, 18, 20, 21, 22 and 24. In these, either a Wheatstone bridge can be adjusted or the ratio of the self and mutual inductances in a given coil can be assumed as known and the resistances adjusted thereby.

The value of this addition is in the increased accuracy and sensitiveness of the method, an increase of more than one hundred fold being assured.

As a standard I recommend two or three coils laid together with their inductances determined and not a condenser, even an air condenser.

ART. XLVIII.—*The alleged Jurassic of Texas. A Reply to Professor Jules Marcou*; by ROBT. T. HILL.

APROPOS of personal criticisms and questions of fact concerning the validity of the work of myself and others upon the later Mesozoic formations in the Southwestern United States, made by Professor Jules Marcou* in many recent publications, such as the *American Geologist*,† *Proceedings of the Boston Society of Natural History*‡, *Science*,§ and especially the paper entitled “*Jura of Arkansas, Kansas, Oklahoma, New Mexico and Texas*,” in this *Journal* for September, 1897 (pp. 197–212), I beg to submit the following statements.

In the month of September, 1853, Professor Jules Marcou, while accompanying a rapidly marching military expedition for the preliminary determination of a Route for a Pacific Railway Survey which was traveling up the valley of the Canadian River, through Oklahoma, the Panhandle of Texas, and Northeastern New Mexico, saw two small, outlying beds of the Lower Cretaceous formation.

The first of these localities, which he termed that of Comet Creek, then in Indian Territory, is in what is now known as G County, Oklahoma, west of the present town of Arapahoe. It has recently been revisited by Mr. T. Wayland Vaughan of the United States Geological Survey and described in this *Journal* for July, 1897. At this spot, Professor Marcou, according to his own statement, remained “only one hour.”||

The second locality was a detached outlier of the Llano Estacado, standing in the broad valley through which the Canadian winds its way through northeastern New Mexico. Here he remained “only three or four hours.” Each of these

* In my writings I have always shown the greatest respect for Professor Marcou, and still have for him the most charitable and friendly feelings. Furthermore, I have always given and shall continue to give him the fullest credit whenever credit is due. The injustice of his attacks upon me and the incorrectness of his statements, which, if unanswered, would prove serious defacements of the scientific record, force me to take note of his accusations, and to add a line of controversy to geologic literature. Professor Marcou's attacks upon the validity of my work have been so direct, numerous and skillfully introduced into the geologic literature of the day under the guise of alleged scientific discussion, that I would deem it unjust not only to myself but to my co-laborers and the United States Geological Survey, with which organization I am connected, and the scientific world in general, not to correct some of his assertions. It is also at the earnest solicitation of several of my co-laborers, who have read this manuscript, that it is submitted to the public.

† *Growth of Knowledge concerning the Texas Cretaceous*, August, 1894.

‡ *The Jura of Texas*, October, 1896, pp. 149–158.

§ *Science*, Oct. 22, 1897.

|| “I was enabled on account of the rapidity of the march of my military escort, to remain at Comet Creek only one hour, and at Pyramid Mount only three or four hours.”—This *Journal*, September, 1897, p. 198.

occurrences, from two to five feet thick at one place and less than fifty at the other, represents an outlying isolated, attenuated outcrop of the great body of Lower Cretaceous which has a development of over 2,000 feet in Texas, and from which they have been disconnected by prehistoric and recent denudation, and to which I have devoted thousands of miles of travel and careful study and field work during my lifetime.

At the first of these localities he collected from a "limestone five feet thick,"* one species of Ostreid ("Gryphæa pitcheri") and at the second from a bed given by him as 30 feet thick, two other species of the fossil Ostreidæ (called by him *G. dilatata* and *O. marshii*). These species, with two or three hundred molluscan forms, since reported by others, are now known to constitute the faunas of the Lower Cretaceous formations of Kansas, New Mexico, and Texas.

Upon the supposed resemblance of the fossil oyster from the first mentioned of these localities to certain forms in the Cretaceous of Switzerland, and the fact that it occurred as a shell agglomerate or "lumachelle" resembling in its lithologic facies similar "lumachelle" of Switzerland, he referred the beds containing it to the "Neocomian" epoch, and has since used this determination as a basis of his subsequent discussion of this system, as other workers discovered and delineated the great series of strata and its areal extent to which this single outcrop has proved to belong. Likewise on the supposed resemblance of the two fossil oysters from Pyramid Mount in New Mexico to forms from the "Oxfordian" and "Lower Oolite groups"† of England and France, he referred these beds to the Jurassic period—an opinion which he has since rigidly maintained and used as the basis for asserting the Jurassic age of various other and entirely distinct strata since discovered and described by later writers throughout the Texas region, and coloring vast areas of what we now know to be Lower Cretaceous and Tertiary, upon maps which he has compiled.‡

By his own statement, Professor Marcou has spent not over five hours of his life-time in observation of the formations under controversy. In fact he has never seen the main body of the Cretaceous in Texas or Indian Territory at all, and has never visited the localities, nor examined the vast collections subsequently reported. "I have explored only a very small part of Texas," he says, "only a simple road in the Panhandle,"§ and I might add, that his road lay entirely through the Permian of

* U. S. Pacific Railroad Explorations, 1853-54, vol. iv, p. 43, H. Doc. 129, Washington, 1855.

† Geology of North America, Zurich, 1858, p. 19, and in several other publications.

‡ "Geology of North America," Geological Map of the World, etc.

§ This Journal, September, 1897, p. 208.

the Canadian Valley and Tertiary of the Llano Estacado, which he called Triassic and Jurassic respectively, and nowhere touched upon the Cretaceous in the State of Texas. Professor Marcou by his writings has at several times conveyed the impression that he had seen the Cretaceous in Texas.* The various journals, itineraries and maps of the Pacific Railway Expedition as published by himself and others, giving a minute record of the progress of the party day by day, show that it nowhere encountered this locality or any other south of the Ouachita Mountains. The fossils from Fort Washita and the Cross Timbers of Texas described by him in his *Geology of North America*, were collected and sent to him by Dr. G. G. Shumard.

Each of his localities have since been thoroughly studied by specially equipped expeditions of the United States Geological Survey and the Texas State Geological Survey. The Tucumcari region has been twice visited by me and the results of my observations published in *Science*† and in this *Journal*‡ and elsewhere.§|| The Texas Geological Survey also made researches in this locality, and published extensively thereon.¶ Professor Alpheus Hyatt several years ago spent a season of minute field work upon the region, and his manuscript report thereon is in the office of this Survey. Thus we have, as opposed to the three hours spent by Professor Marcou, the observations of three independent parties, who have devoted days and months to the locality. Each of these parties (although both Professor Hyatt** and myself†† were at first predisposed towards Professor Marcou's conclusions, and made the mistake in print of partially supporting him) have all arrived, after careful and impartial study, at conclusions contrary to his. *I have shown beyond all doubt that the deposits which he called Jurassic are Cretaceous—not only Cretaceous, but of a Cretaceous horizon which I believe to be of the same general formation but of a horizon stratigraphically above the rocks which he, himself, collected at Comet Creek and called "Neocomian."* It is also extremely doubtful if the Comet Creek beds are homotaxially equivalent to the Neocomian, as he alleges.

* "I have seen and studied the strata of the Upper Greensand and Marly Chalk, in the bed of Little River," etc., "and also on the Elm Fork of Trinity river"—Professor Marcou in *American Geologist*, August, 1894, p. 100.

† July 14, 1893.

‡ September, 1895, p. 234.

§ Report on Underground Waters, Washington, 1892.

|| Bull. Geol. Soc. Amer., May, 1894, p. 332.

¶ Third Annual Report, pp. 201 et seq.—A controversial article fully answered in *Science*, July 14, 1893.

** 11th Annual Report U. S. Geological Survey, Part 1, p. 97–100.

†† Circular letter, Austin, Texas, 1888.

Professor Marcou established his Jurassic at Tucumcarri solely upon two species of fossil oyster. Each of these expeditions, in addition to the two fossil oysters found by Professor Marcou, collected large Cretaceous faunas of over a dozen species, similar to that which occurs in Grayson County, Texas, *above* the Comet Creek horizon (Preston Beds) which he has himself referred to the Cretaceous, and published lists thereof in the publications above mentioned.* His repeated assertion that his adversaries will not or have not published figures of these fossils is unjust. These fossils are mostly all well known species which have been fully illustrated by their authors and are in the United States National Museum, the State Capitol of Texas, and at Johns Hopkins University, where they are accessible to all interested, and have been, are being, or will be duly published at the proper time and place as the systematic work of publication of the Cretaceous stratigraphy and paleontology of Texas progresses.

Professor Marcou has said† that his "observations, instead of being accepted and used for further development of our knowledge of the Texas Cretaceous, were, on the contrary, opposed systematically." This statement is true except so far as the last words are concerned, for the opposition was largely based upon independent investigation of parties who, in some instances like the writer, were predisposed to accept his conclusions. Not only has Professor Marcou rigidly maintained the fundamental errors of his conclusions as to age, but has used them as a pretext for assaulting the observations, often with crimination and misquotation, of every later worker who has since more thoroughly studied the field, or distorted their language into confirmations of his own erroneous conclusions.

The foregoing is a brief statement of the facts which gave rise to a controversy, which has pervaded geologic literature for nearly forty years, and which is marked by unparalleled bitterness and accusations of American geologists as a body on the part of Professor Marcou. This controversy will be again referred to in the later pages of this paper, after we say a few words in direct reply to his article in the September number of this Journal.

A most serious, but less important defect of his paper is the fact that he omits reference to most of the recent literature which shows the fallacies of his conclusion concerning Comet Creek and Tucumcarri, and these omissions leave the general reader, who may judge the work of others by his article, under a false impression concerning the questions involved. Sys-

* Lists of these fossils were published by me in *Science*, Sept. 1, 1895, and this *Journal*, Sept. 1895.

† *American Geologist*, August, 1894, p. 100.

tematic observations on the stratigraphy of these formations, written by me, and, at my request, by Messrs. Stanton and Vaughan, can be found in this Journal from 1877 to the present year, in the papers to be enumerated presently. Within the past few years I have paid special attention to these isolated but related localities in Kansas, New Mexico and Trans Pecos, Texas, and their relations to the Central Texas region where the main area of the Cretaceous lies in continuous section. The three papers specially showing the identity of Professor Marcou's Jurassic of New Mexico with the beds of the Washita Division in Texas, are entitled "Outlying Areas of the Comanche Series in Kansas, Oklahoma and New Mexico," with *ex parte* paleontologic determinations by T. W. Stanton and F. H. Knowlton, published in this Journal of September, 1895; "Section of the Cretaceous at El Paso, Texas," by T. W. Stanton and T. Wayland Vaughan, this Journal, vol. i, p. 21, 1896; and Additional Notes on the Outlying Areas of the Comanche Series in Oklahoma and Kansas" by T. Wayland Vaughan, this Journal, July, 1897. These three papers cover every well known essential point concerning these regions and should be read by all who wish to know the true merits of Professor Marcou's determinations of the localities discussed.

Furthermore, two previous bulletins of the Geological Society of America,* written by me upon the paleontologic and stratigraphic relations of the Cretaceous formations of Indian Territory and Texas adjacent to Red River—the localities from which the Cretaceous fossils described by Professor Marcou, in his *Geology of North America*, were collected—set forth the details of the comprehensive section of the Cretaceous developed in that region by which the stratigraphic position of Professor Marcou's isolated outcrops can be located in the general section. Finally, concerning the paleontology of the entirely distinct Trinity Division as published in my Arkansas Report—the only one of my papers to which Professor Marcou refers,—I will state that the paleontologic descriptions and figures of that volume were fully revised and republished by me in a paper entitled "The Invertebrate Paleontology of the Trinity Division," published in the Proceedings of the Biological Society of Washington, vol. viii, pp. 9-40, Plates I-VIII, June 3, 1893, and that this later paper, not the Arkansas Report, represents my views of the fauna discussed. In this later paper the description of the form from Arkansas described by me under the name of *Ammonites walcotti*, is fully revised by Professor Hyatt and redescribed by me, and my previous generic and specific comparisons as quoted by Marcou (p. 199)† are abandoned and superseded.

* Vol. ii, pp. 503-528, 1891, and vol. v, pp. 297-338, 1894.

† This Journal, Sept., 1897.

Professor Marcou completely ignores this paper in his writings, and seems to present me to the public as having said things which were never intended.

Not only does he fail to set forth fairly the work of others, but he even appropriates from them their own substance and converts them to his own end. No better illustration of this can be found than the sentence on page 211 where he speaks of the "true Washita Division as I established it as long ago as 1853 when at Comet Creek near Fort Washita." This assertion that he established the Washita Division is absolutely untrue. The two feet of beds at Comet Creek which he saw in 1853 (and this locality is not near Fort Washita, as he states) were never called by him the "Washita Division" or ought else but "Neocomian," nor was the term ever used in scientific literature by him until after it had been invented by another. The classification of the beds of the Texas Cretaceous into "divisions" and the term "Washita Division" was originally made by me and published in this Journal for April, 1896, and amplified in my later papers. Marcou's "Neocomian," Comet Creek *bed*, is only a single horizon in one of the eight great formations composing the Washita Division, seven of which are shown in my paper entitled the "Geology of Parts of Texas, Indian Territory, and Arkansas Adjacent to Red River (Bull. Geol. Soc. of America, March, 1894) and one of which, the Grayson Marls, has been added by Cragin.

His article is also so full of conclusions with which few Americans will agree, that we can only point out at present a few of the scientific points of disagreement. He dismisses (p. 204) Mr. Knowlton's careful study and identifications of the Dicotyledons* with the assertion that "no conclusion can be drawn from such a meagre florula." Mr. Knowlton's florula enumerates five characteristic Dakota species. The occurrence of a Dakota-like dicotyledonous flora in Marcou's "Jurassic" beds both in Kansas and also at Gallisteo, New Mexico, as has been noted by Newberry,† is certainly against his hypothesis, but paleo-botanists and geologists in general, who are acquainted with the western United States, know that this flora is distinctly Cretaceous in its facies, and not Jurassic. Professor Marcou neglects to state, and I myself had overlooked the fact, that Newberry‡ many years ago noted in New Mexico the occurrence of dicotyledonous plants with Marcou's Jurassic oyster in sandstone called Jurassic by Marcou, near Gallisteo, New Mexico. The *cycad* which the latter mentions (p. 204) (*Cycadeoidea munita* of Cragin) was found in the

* Given in my paper in this Journal of September, 1895, p. 212.

† This Journal, vol. xxviii, 1859, p. 33.

‡ *Ibid.*

Tertiary Plains drift, and derived from a geological position unknown, and has been studied by Professor Ward. Even if it should prove of Purbeckian age it would still be from a much higher horizon than Professor Marcou's alleged "Oxfordian," "Oolitic," Jurassic of New Mexico.

On page 198 he accuses me "of making a clean sweep of the marine American Jura," and quotes a paragraph from me in which I stated that "there are reasons for suspecting that no marine Jurassic formations of Atlantic sedimentation have as yet been discovered north of Argentina on the present Atlantic slope of the American hemisphere." In quoting this paragraph Professor Marcou apparently forgets that he, himself, has distinctly said in italics (*Geology of North America*, p. 19), that "*the Jurassic rocks do not exist on the Atlantic slope of North America nor anywhere east of the Mississippi River.*" My assertion of practically the same proposition is maintained by every known fact, unless the Wealden beds, which are not positively known to be marine and which are classified with the Cretaceous by a preponderance of authority, are Jurassic as maintained by Marsh—(merely a question of classification, as I have recently shown in *Science**). Furthermore, as he referred the Tucumcarri beds under discussion to the "Oxfordian" and "Lower Oolite"† of the Jura, they are in no manner to be confused with the Wealden, or "Jurassic" of Marsh. Neither does the sentence quoted from me make "a clean sweep of the American marine Jura," for it in no manner alleges that there is no Jurassic on the Pacific slope, or in the Black Hills of Dakota, where, as is well known, Jurassic formations, in no manner related to those of New Mexico, so-called by Professor Marcou, do occur.

Concerning his general classification and tabular view of the whole country south of the Arkansas, pp. 208–211, I will state that it has no value and cannot in any manner be fitted to known conditions. For instance, I have shown that the Cheyenne Sandstone of Kansas which he places at the base of his section, contains dicotyledonous flora and occurs stratigraphically about midway in the Lower Cretaceous of the Texas section, and does not belong to my Trinity Division at all, as at first supposed by Cragin. His "Tucumcarri Division (B) and "Neocomian Division," are synchronous formations, and embrace beds far more nearly allied to the Gault than Neocomian. His descriptions of these divisions are purely imaginary creations, stratigraphically incorrect, and altogether out of harmony with the natural occurrence of the rocks or the literature thereon. The whole table is ingeniously constructed by compilation of the works of the very authors he condemns.

* December 18, 1896, pp. 918–922. † *Geology of North America*, pp. 19–20.

Professor Marcou has long imagined that brief observations in these outlying areas have constituted him an authority on the greater Texas region which he has not seen, and made them the basis for creating, at his study at Cambridge, such tabulations as above mentioned and dictating where work should and should not be done in the Cretaceous region of Texas. This article under discussion is especially profuse in such suggestions. I can dismiss them in a lump as follows: The monograph on the fossils which have been called "*Gryphæa pitcheri*," was written and ready for the printer a year ago, and was transmitted to the Director for publication on January 13, 1897. When it does appear it will further show by the most conclusive stratigraphic and paleontologic data, together with a careful study of the development of the forms, the identity of his alleged Jurassic species from Tucumcarri with the forms called "*Gryphæa pitcheri*" in the Cretaceous of Texas, and the form which he names *Gryphæa kansana* (page 203) from Kansas. For the two or three specimens of the last mentioned form which he states that he possesses, and which I have seen in his studio at Cambridge, we possess hundreds of specimens showing every stage of the development. Furthermore Mr. T. W. Stanton is now solely engaged upon the descriptive paleo-zoology of the Cretaceous of Texas, a work which I had to abandon owing to pressure of other duties, and his work will be reliable and authoritative. Professor Lester F. Ward is likewise studying in a similar manner the paleo-botany.

Prof. Marcou's remark about "special need of investigation in the vicinity of Austin and Fredericksburg" can be fully answered by stating that in addition to my previously published papers on this region, there is in type for the Eighteenth Annual Report of the U. S. Geological Survey a large and comprehensive work upon this region by Mr. Vaughan and myself, giving every detail of its stratigraphy with maps and illustrations. Furthermore, we have in process of publication, four atlas sheets of this region. I have also personally conducted Mr. Stanton over this country, and he is illustrating and describing the paleontology as fast as accurate methods will permit. He has just returned from that region, where he has made additional collections.

We have already shown that his charges that his opponents will not visit his localities are unjust. Just one year ago when I lay at Muskogee, Indian Territory, upon what was then supposed my death-bed, I turned over my camp equipment to Professor Lester F. Ward and Mr. T. Wayland Vaughan, and requested them to visit the Kansas localities, which they did. Mr. Vaughan also thoroughly studied all the outlying areas to

the south thereof, including Professor Marcou's Comet Creek locality, and his results have been fully published in this Journal for July, 1897. Professor Ward, who accompanied Mr. Vaughan to the Kansas localities, is now again in the Kansas region,* studying the fossil flora. Professor C. S. Prosser has also lately published an excellent paper on the stratigraphy of the Kansas† localities, which confirms the conclusions of Professor Marcou's opponents. The invertebrate paleontology of the same region is in process of publication by Professor Cragin.

After all the complaints pervading Professor Marcou's papers against others who are working as hard and consistently as they can upon the problems of the region, for not publishing hastily, and charging that "poor stratigraphy and poor paleontology have long enough prevailed," etc., etc., he apparently sees no inconsistency in immediately creating in this article a new species of oyster (*Gryphæa kansana*) without one word of description or illustration.

His accusation (page 201) that Dr. Charles A. White changed "the generic and specific name" of his (Marcou's) *G. pitcheri*, alias *G. rœmeri*, etc., etc., to *Exogyra forniculata* is untrue. Marcou, himself, was the first to use the generic name *Exogyra* for this species, in his first paper in the original Whipple report and elsewhere,‡ and continued to use it for some time, as shown in the extracts from his writings given on a later page. Although I believe Dr. White's *Exogyra forniculata* may be identical with Marcou's *G. pitcheri*, there is still room for much doubt upon this subject.

Inasmuch as this *Gryphæa* and the thickness of the beds containing it is made the basis of many charges against others by Professor Marcou, it may be well to introduce here the following extract from his own writings concerning it which will be referred to later in this paper.

His record of the thickness of the Comet Creek beds and the various names which he gave to the fossil found there ("*Gryphæa pitcheri*") and which almost exclusively composes the rock, is as follows :

1855. "This limestone is only five feet thick; it is of a whitish grey color containing an immense quantity of Ostracea which I consider (provisionally) as the *Exogyra ponderosa* Roemer; having the closest analogy with the *Exogyra* of the neocomian of the environs of Neufchatel."—U. S. Pacific Railroad Explorations, 1853-54, vol. iv, p. 43, H. Doc. 129, Washington, 1855.

* Prof. Ward has returned since this was written, bringing with him over forty boxes of Cretaceous fossil plants.

† Report of Kansas State Geological Survey, pp. 96-181, 1897.

‡ Geology of North America, p. 17.

1858. "This limestone is only five feet thick; it is of a whitish-gray color, containing an immense quantity of fossil Ostracea, which I consider as identical with the *Exogyra* (*Gryphæa*) *pitcheri* Mort., having the closest analogy with *Exogyra couloni*, of the Neocomian of the environ of Neufchatel (Switzerland).—Geology of North America, Zurich, 1858, p. 17.

This passage purports (Geology of North America, p. 7) to be a "verbatim" copy of the preceding paragraph, and is copied from the chapter in the latter work (p. 9) entitled "Extract from Report of Explorations for a Railway Route, near the Thirty-fifth Parallel of Latitude from the Mississippi River to the Pacific Ocean, etc., Washington, 1855, H. Doc. 129." It should be noted that he here, as in the preceding quotation, refers the genus to *Exogyra*.

1858. In the literal copy and translation of Professor Jules Marcou's field notes by W. P. Blake, p. 131, vol. iii of the Pacific Railway Reports, quarto edition of 1856, the Comet Creek locality near Camp 31 is described as composed of "three or four broken beds with crinoids* disseminated here and there as if the ruins were formed of a lumachelle limestone of Neocomian age. This lumachelle is formed by the fragments of *Ostrea aquila* or *couloni* or a variety, for it is smaller the four beds of lumachelle are two feet."

Concerning these notes, however, Mr. Marcou later said: "I here declare that I know nothing of the publication of the edition in quarto of these reports, and that I decline all responsibility as to the use that may have been or may hereafter be made by others of my official note books," etc. (Geology of North America, etc., Zurich, 1858, p. 1.) Nevertheless he himself, now (1897) cites them as authoritative in his recent article, p. 205.

1858. On page 27 of the Geology of North America, Mr. Marcou says, in discussing his Neocomian in America, of which this is the only locality recorded as seen by him, that "its thickness varies from 6 to 50 feet."

1862. "I have never seen Morton's original specimen. . . . I am led to believe that I did not meet with the true *G. pitcheri* of Morton in my explorations with Captain Whipple's party. Mr. Ferdinand Roemer having the opportunity of seeing, in the company of the late Dr. Morton himself, the original specimen at Philadelphia, I naturally followed his identification of *G. pitcheri*; and if Roemer has made a mistake I was misled by his description . . . Thus we shall have three species of *Gryphæa*: 1, the *G. tucumcarrii* of the Jurassic rocks of Pyramid Mount (New Mexico); 2, the false *G. pitcheri* of Roemer and Marcou, or the false *G. pitcheri* var. *navia* of Conrad and Hall of the Cretaceous rocks of the false Washita River (Texas) which may be called *G. roemeri* in honor of its first discoverer, Mr. F. Roemer, and, 3, the true *G. pitcheri* Morton, which I have never seen, and, consequently,

* This word does not occur in the French version of the notes, in which *G. couloni* is also followed by a question mark.

on which I cannot give any information as to its stratigraphical position and association with other fossils.—Proc. Boston Soc. Nat. Hist., vol. viii, p. 95, 1862.”

1889. “As to the *Gryphæa pitcheri* which Mr. Hall calls *var navia* it is the true *G. pitcheri* of Morton and Roemer found by me at Comet Creek near the false Washita river.—American Geologist, September, 1889, p. 163.”

1896. “The first strata of this Cretaceous system contain at Comet Creek, Fort Washita, etc., an immense number of *Gryphæa rœmeri* Marcou (formerly called *G. pitcheri* by Roemer and Marcou). The *Gryphæa arcuata* are so numerous as to recall the ‘Limestone of the Lias of England, France, and Germany.’ These first beds, which may be called the ‘Caprina and *Gryphæa Rœmeri* limestone; are the bottom beds of the American Neocomian or Lower Cretaceous.”—The Jura of Texas by Jules Marcou, Proc. of the Boston Soc. Nat. Hist., vol. xxvii, p. 157, Boston, October, 1896.

The foregoing extracts show that he has successively called this Comet Creek species “*Exogyra ponderosa* Roemer,” “*Exogyra pitcheri*” with analogy with “*Exogyra couloni*”; “*Ostrea aquila* or *couloni*?” “*Gryphæa pitcheri*,” “*Gryphæa rœmeri*,” “*Gryphæa pitcheri*” and *Gryphæa rœmeri*.”

The paragraphs in Professor Marcou’s paper to which I personally take exception are such as that on page 199, in which he makes direct charges upon my veracity and the motives and correctness of my work, citing “an example of carelessness, not to use a stronger word, in quoting a plain paleontological fact,” which “shows how unreliable Mr. Hill is when he writes on paleontology,” and accusing me of endeavoring by “extraordinary alteration” and misquotation of D’Orbigny to make a certain species of Ammonite appear of Cretaceous instead of Jurassic affinities.

These accusations on Professor Marcou’s part are absolutely without foundation, as anyone can see by comparing my original assertion with his extraordinary misrepresentation of it. What I said was as follows :*

Careful examination of the literature and specimens of the Boston and Washington libraries and museums failed to reveal any figured species with which this one can be identified. *It resembles generically the group Harpoceratidæ (genus Ludwigia, Boyle), which is peculiar to the upper jurassic of Europe and also Ammonites yo, D’Orb, of the lower neocomian. The absence of this ammonite from the great mass of the Trinity strata, except in the place indicated, suggests that it may be an older fossil reimbedded in the Trinity, but its preservation and delicacy of structure would seem to render this impossible.*

* Neozoic Geology of Arkansas, p. 128.

By omitting all the words of this paragraph except those in italics, which he brings together and by substituting the word "Cretaceous" for "Neocomian," he succeeds in establishing his remarkable construction of a proposition which I did not utter, upon which he could base his assertion that I "undertook to change the age of *Ammonites yo*," which cannot be explained otherwise than that I "wanted to sustain my classification of the Trinity Division in the Cretaceous, quoting in his (my) favor the great D'Orbigny." These charges are repudiated by every passage referring to the species of *Ammonites* to be found elsewhere in the volume referred to, in which I repeatedly present the Jurassic affinities of this form; but as he well knows, in another paper, the species was revised by me and the previous description in the work which he quoted was abandoned. All the other passages referring to the age of *Ammonites walcotti*, both in the Arkansas Report,* and the revision thereof are here reproduced in full, and I beg the candid reader to compare them with Professor Marcou's statement, in order to see if there is ground for his accusations.

Arkansas Report, p. 125.—Reviewing the stratigraphic evidence afforded by Trinity formation, it seems to be clearly older than any Cretaceous rocks hitherto described in this country, a fact which is verified by the paleontology as shown in the next chapter.

The stratigraphic position beneath the lowest Comanche series, which is of very early cretaceous (neocomian), and the extreme difference in the character of the sediments and fossils, confirm the opinion that the rocks are either uppermost jurassic, lowest cretaceous (Wealden) or transitional jura-cretacic. They are at least older than the oldest American cretaceous rocks hitherto known, and mark the littoral stages which characterized the beginning of the first grand subsidence of cretaceous times.

Proceedings of the Biological Society,† pp. 37-38: Only one specimen of this species has thus far been discovered. It occurred in association with *O. franklini*, *Vycaria lujani*, *Eriphylla arkansensis*, and other mollusks herein described. The form very much resembles in outward appearance the figures of the genus *Oxynticerus* of Hyatt, as given by Zittel and Steinman in their Manuals, but Professor Hyatt refers it to *Neumayria*, and contributes the following comments upon the specimen:

"Your *Ammonites walcotti* is probably a *Neumayria*. The aspect is Jurassic, but this group, Upper Jura, and the species

* Neozoic Geology of Southwestern Arkansas. By Robert T. Hill, Assistant Geologist.—Annual Report of the Geological Survey of Arkansas for 1888, vol. ii, pp. 125-128.

† Paleontology of the Cretaceous Formations of Texas. The Invertebrate Paleontology of the Trinity Division, by Robert T. Hill.—Proceedings of the Biological Society of Washington, vol. viii, pp. 37-38, June 3, 1893.

nearest *walcotti* occurs in the very top of the Jura of Central Volga stage, supposed by some to be similar to the Purbeck in the upturn at Malm. The obscuration of a portion of the sutures occurs over the most important part of the outer side, and the structure of the abdomen, which is rounded and has no keel, is not very consistent with the reference either to the *Neumayria* of the Jura or the so-called *Neumayria* of the Cretaceous. Nevertheless it agrees better with those of the Jura than the Cretaceous ones referred to the same genus by Nikitin."

Whatever may be the range of this genus in Europe, the writer is inclined to the belief, from the stratigraphy and association, that its occurrence in Arkansas is lowest Cretaceous, and Professor Hyatt's opinion serves to strengthen the position of the writer in his reticence in earlier papers in expressing a more definite assignment of the Trinity beds before minutely studying the accompanying faunas. The specimen was collected in the banks of Town Creek, one mile southeast of Murfreesboro, Arkansas. Named in honor of Mr. C. D. Walcott.

Nowhere in these writings do I quote or have I quoted D'Orbigny, and even my citation of a doubtful resemblance to a species of his (which citation was entirely abandoned in the revision of the species), cannot be interpreted as a quotation. The very first sentence of the paragraph upon which Professor Marcou constructs this charge distinctly shows that no identity between the species was intended. Whether Mr. Marcou's assertion that D'Orbigny's species came from the Jurassic and not the Cretaceous is true or not, I do not know (for no copy of D'Orbigny's *Paleontologie Française* is accessible to me to verify his references), but even if it is true, the matter is entirely secondary to the entire tenor of my writings and was set right by myself through its omission in the later publications.

Professor Marcou states on the same page that "he has shown with accuracy and details in the *American Geologist*, Dec., 1889, . . . that the whole fauna without a single exception is composed of Jurassic fossils." I am perfectly aware of the fact that in his paper cited,* he took the list of fossils illustrated by me, species for species, and asserted† their identity or resemblance, according to his fancy, with some Jurassic species of Europe, making them allied to forms from various horizons of Europe, such as the "Portlandian," the "French Jura," "Argovian," "Sequanian," the "Upper Lias," and the "Kimmeridian." These mere assertions are all the "accuracy and detail given." His identifications have so little basis of fact that I merely pass them by unnoticed and do not yet

* Jura Neocomian and Chalk of Arkansas; by Jules Marcou, *American Geologist*, December, 1889.

† *Ibid.*, pp. 362-363.

accept them. This fauna is undoubtedly one of the oldest of the Comanche Series. In my Arkansas report I said that it resembled the Wealden and Purbeckian, a position which I still maintain, and Professor Marcou has proved nothing further concerning it. He has issued similar manifestoes upon the appearance of other lists of species from the Southwest, notably the one identified by Stanton and published by Dumble from the Washita Division at Kent.* Here he takes a dozen or more of the best known and commonest fossils, not of Wealden affinities, but from the uppermost division of the Lower Cretaceous, and refers each of them serially to Jurassic forms. His *ipse dixit* is all the basis there is for such correlations.

The following extracts from Professor Marcou's discussions of a species of Ammonites, a family of much more value for stratigraphic correlation than Ostreidæ, show that he, rather than others, used the peculiar methods in paleontological discussions which he has attributed to them. He found no Ammonites in the "Jurassic" Tucumcarri region, and noted their supposed absence. In his "Geology of North America" (p. 33, Plate I, fig. 1), he gave an excellent figure of a "Cretaceous" species which he named *Ammonites shumardii*, after Dr. George G. Shumard, here called by him "the learned geologist of Arkansas," who collected all the species from Fort Washita and Texas, near Red River. These localities, which Marcou has never seen, are several hundred miles distant from Tucumcarri, and judging from his writings he is ignorant of their stratigraphy, although they have been visited several times by the writer and made a special study by him.†

Furthermore, as I have seen, this species of Ammonite occurs by the hundreds in the Red River localities from which Marcou's type specimen was sent, in a horizon stratigraphically below beds containing the majority of the species now known to constitute the fauna of his alleged "Jurassic" of the Tucumcarri region, and *above* the horizon of his Comet Creek "Neocomian."

In 1888 Professor Alpheus Hyatt found this confessedly Cretaceous species of Professor Marcou's in the supposed "Jurassic" beds of the Tucumcarri region of New Mexico. Professor Marcou, since the latter event, endeavored to reconcile these facts in a most remarkable manner. Without awaiting publication by Professor Hyatt, and upon what authority we do not know—for Professor Hyatt has never published other than a brief administrative report‡ on his work so far as

* American Geologist, November, 1893.

† See papers previously cited.

‡ Eleventh Annual Report U. S. Geological Survey, Part 1, pp. 97-100.

I am aware—Professor Marcou immediately proceeded to announce, that* “The fauna of the upper part of the Jurassic strata of Pyramid Mount at the Tucumcarri, thanks to the collection made there in 1889 by Prof. A. Hyatt, is now well known.”

Later, however, when he pressed Professor Hyatt, who has, perhaps wisely, kept out of the controversy, for an opinion concerning the age of the Ammonite, he received a very decisive answer as follows:† “I think there can be no reasonable doubt that it belongs to the Inflatu group of the genus *Schlœnbachia*, hitherto found only in the Cretaceous.”

Not daunted by this decisive contradiction of the Jurassic age of this species by Professor Hyatt, Professor Marcou next proceeded to force the species into his Jurassic system, whether or no, by making a new paleontologic law to suit the case as follows: “When considered in connection with the surrounding fauna of the Tucumcarri area, the *Schlœnbachia* found there indicates that in America the genus appeared near the end of the Jurassic epoch, a fact constantly indicated for many other fossil forms which appeared sooner in America than in Europe.”‡

To demonstrate the last proposition he asserts that he§ (Marcou), “received a very remarkable confirmation” of “his” opinion concerning “the appearance of the Jurassic genus *Schlœnbachia* during the Jurassic epoch in America,” and says that Aguilera gives a description, with figure, of a *Schlœnbachia* “found among a whole Jurassic fauna” at Catorce. By consulting the work referred to|| it is seen that no such statement is made, and that the Mexican *Schlœnbachia* is not reported with the other Jurassic fossils described by Aguilera, but is the only fossil found in the limestone of the upper part of the upper division of their section, and is referred by him to the upper part of the Lower Cretaceous.¶

The fact that he, himself, had originally given the Ammonite a Cretaceous position—an insurmountable obstacle to its alleged Jurassic occurrence in New Mexico—was further remedied as follows: Mr. Dumble found a specimen of *Ammonites leonensis* at Kent** in the same bed with the cognate of *G. pitcheri*, which Marcou confesses†† is his alleged

* American Geologist, August, 1894, p. 102.

† “The Jura of Texas,” by Jules Marcou,—Proc. Bost. Soc. Nat. Hist., vol. xxvii, p. 155.

‡ Same publication as above, p. 155.

§ Proc. Bost. Soc. Nat. Hist., p. 155.

|| Boletín de la Comisión de México, Num. 1, pp. 49 and 50 (Mexico, 1895).

¶ Ibid., p. 49. ** Previously cited, p. 462.†† “The Jura of Texas,” p. 153.

Jurassic *Gryphæa dilatata* of the Tucumcarri region. To offset this additional evidence of the Cretaceous age of the beds, Mr. Marcou, after showing to his own satisfaction that all the common species collected by Mr. Dumble from these uppermost beds of the Comanche Series are "Jurassic," erroneously says that the "*Ammonites leonensis* Conrad is not that species at all, but the *Ammonites shumardii* Marcou. "It is true that I placed this species in the Cretaceous of Texas, but I was impressed by its form. . . . If the specimen had come to me with a *Gryphæa tucumcarri*, I should not have hesitated to refer it to the Jurassic of Texas. But it came to my hands collected by a person not a geologist, who put together all the fossils obtained during a military march through Texas." It is needless to say that the two species of Ammonites cited are quite distinct. Such is an example of how he, himself, has by misquotation changed the geologic age of an Ammonite and thus gained support for his erroneous conclusions—an act identical with that which he has so skillfully tried to fix on me in the case of *A. walcotti*.

Another unfounded accusation is his assertion that I have misquoted him when I spoke of the Comet Creek bed "as being composed of a single bed of limestone five feet thick," which he alleges is "another example of want of exactness in quotation in Mr. Hill" (p. 205). The alleged quotation on my part is from the first two of the extracts from his writings previously given, wherein he distinctly says "This limestone" (not limestones) "is five feet thick." On the other hand, the only passage of Marcou's writings seen by me in which this formation is spoken of as more than one bed, is in Blake's publication of his (Marcou's) notes—the same which he has hitherto repudiated with such vehemence but which he now, for the first time in forty years, cites as authority as already noted. But in doing this he even misquotes these notes, which distinctly say that there are three or four of these beds, not five as Professor Marcou now alleges they state (p. 204). It is likewise apparent that Marcou in his various writings has himself variously given a thickness of "2, 5" and from "to 50" feet to these beds. The truth of the matter, as shown by Mr. Vaughan in his recent paper,* is that they are probably only two feet thick.

Such are some of the examples of Professor Marcou's perverted charges wherein he states that I, who, according to his own statement, am the only man in American science who has endeavored to treat him with courtesy and give his writings due credit, and who has tried to record facts truthfully, have misquoted and corrupted paleontologic facts with a motive.

* This Journal, July, 1897.

After perusing the foregoing pages one cannot but wonder why Professor Marcou should wrongfully accuse others of maliciously misquoting. Let the reader put side by side the two first abstracts we have given from his writings concerning the Comet Creek *Gryphaea* on pp. 17-18. The second of these was published by him as a verbatim copy* of the first, yet in this alleged verbatim copy he has changed the name of every species mentioned in the original and made other additions, and this, too, without one word of explanation. These instances together with the misquotations elsewhere given of Aguilera the Mexican Geologist, of himself and myself, are but a few of the many examples which could be given showing that he has certainly exceeded the ordinary limits of toleration in such practices, in which I have never, intentionally, indulged in, as he charges.

In the paper in the September number of this Journal, Professor Marcou also accuses Messrs. Hall, Roemer, Shumard, Gabb, Charles A. White, Hill, Cragin and Stanton of confusing species, and I can but consider it an honor that he should have selected my head, above all these distinguished authorities, upon which to pour the last and most concentrated dregs of his wrath. His many papers are bristling with similar assaults devoted to denouncing the scientific value of the work of James D. Dana, James Hall, J. S. Newberry, F. B. Meek, W. P. Blake, T. A. Conrad, J. D. Whitney, C. A. White, J. J. Stevenson, with side notes on nearly every American geologist of the past fifty years, against whom as a whole he has also launched certain epithets. It can be readily seen that his assaults upon me are felt less keenly when one considers the distinguished company with which I have been placed by him. This will be made still more apparent by the following brief résumé of the controversy which he has so long conducted.

The invalidity of Professor Marcou's conclusions concerning the Jurassic age of the New Mexican locality was early shown in many papers by the principal American geologists, of the decade of 1855-1865, among whom were W. P. Blake, B. F. Shumard, J. S. Newberry, F. B. Meek, T. A. Conrad, James Hall, James D. Dana, Lesquereux and others. The whole substance of the controversy and proof of the inaccuracy of Professor Marcou's conclusions, have been ably set forth by Professor Dana in this Journal for November, 1858, p. 323, and January, 1859, pp. 137-141. This was the original Marcou controversy, which died out in the year 1867. The later and detailed studies in the field by the present school of geologists, have confirmed by stratigraphic research that these

* See *Geology of North America*, p. 7.

older writers were correct in their affirmation of the Cretaceous age of the alleged Jurassic beds of New Mexico.

From 1867 to 1884 there was a cessation in the flow of publication from Professor Marcou's fertile pen, which did not resume until after the appearance of the writer's first papers on the geology of the Texas region, in 1886, after I had endeavored to give a résumé of Marcou's work in Oklahoma and New Mexico.* In attempting to give him credit, however, I apparently started Professor Marcou's pen again—which he resumed, after seventeen years of silence during which his history was a blank to me. Since this time his contributions have been as frequent and pointed as before. Time does not permit me to enumerate or refer to all of Professor Marcou's publications. They are all marked by similar statements to those given in the article which has brought forth this paper, only differing in the violence of the personalities indulged in.

His publications have been particularly severe in their denunciation of all American geologists. Professor James D. Dana, who has always been considered as the embodiment of honor and integrity, is accused of "distorting and misrepresenting facts,"†‡ of falsifying titles of his (Marcou's) papers,§ of "persecuting|| and waging war upon him," of having "filled up his Journal, since he is geological editor, with papers of controversial nature, without a single observation made in the field or museums" and charged with "persistent and blind resistance against progress," "opposition *a outrance* and his *parti pris* to ignore a system." He also states that Dana and Hall have not excuses of distance to travel over or want of facilities and opportunities to create their colossal error." "His (Dana's) efforts during 44 years have been directed to keeping life in wrong conclusions and in the opposite direction of the truth," and together with James Hall "has misled those who followed their views by various paleontological determinations and false classification."¶ He accuses Professor F. B. Meek—the ideal of exactness in paleontologic method—of "mixing strata together without regard to stratigraphy, lithology, or even paleontology," and states that Professor J. J. Stevenson makes use of language "such as it is impossible even to quote it."**

His assaults upon American geologists reached their climax, however, in his paper on "American Geological Classification

* Bull. 52, U. S. Geological Survey.

† "A Reply to the Criticisms of James D. Dana," by Jules Marcou, Zurich, 1859.

‡ Geology of North America, Zurich, 1858, p. 7.

§ American Geological Classification, by Jules Marcou, Cambridge, 1888, p. 9.

|| Ibid., pp. 22, 23.

¶ Ibid., p. 39.

** American Geologist, Sept., 1889, p. 156.

and Nomenclature," published at Cambridge, 1888. This is a bitter attack upon nearly every American geologist of the past half century, all of whom except myself, of whom Mr. Marcou was then fulsome in his praise (for reasons elsewhere explained), are accused of outrageous personal conduct, such as "suppressing facts," "falsifying," "misquoting," "incompetent observations," etc., etc., and speaks of "the constant and utmost opposition" of Messrs. James Hall, T. Sterry Hunt, W. E. Logan, James D. Dana, the two Professors Rogers, and Professor C. H. Hitchcock, and to this list he adds in his own handwriting on page 8 of the copy sent to me, the name of Charles D. Walcott. Also, on page 11, he accuses Professor Dana "in accordance with his usual practice of giving credit to those to whom it does not belong, and pretending that the Lower Silurian is called Champlain by Mather." On page 17 he accuses Mr. Walcott of having been "misled by the erroneous notions constantly and perversely put forward by Mr. Dana."

I could quote from his various writings many other such denunciations, chiefly directed at Professor Dana as the head and leader of American geologists, just as he now assails me because I have been a pioneer in the late studies of the Mesozoic in the Texas region. I could fill a volume with similar attacks upon other men of science, such as his accusations of a like kind against Newberry, Hall, Stevenson and others. It was owing to the error of his deductions, his habit of absorbing to his own credit every new discovery in the Southwest, and printing imaginary geological maps of the United States, of persistently misquoting other writers, of accusing every one of paleontologic or stratigraphic incompetency, and of indulging in personal abuse and vituperation, that Professor Dana at one time demanded that the Boston Society of Natural History should investigate him, and in later years ignored him entirely.

So far as I am aware, his conclusions on the subjects discussed are not accepted by a single living geologist in this country or abroad, and he has hurled criticisms, similar to those now made against me, at the head of every prominent American geologist who has lived since he first came to this country. During the first few years of my studies I was inclined to believe that he might have been right in his conclusions concerning the Jurassic age of the beds of the Tucumcarri region, and committed this opinion to print. So long as I leaned to his opinions he was fulsome in his praise, bestowing upon me effusive compliments as to my ability, etc., etc., and even writing among others of a similar flattering nature, the following notice* of

* *Jura Neocomian and Chalk of Arkansas.*—Marcou. From the *American Geologist*, December, 1889, pp. 366-367.

the same Arkansas Report which, in the September number of this Journal, he so severely condemns :

“On the whole, Volume II of the Arkansas geological report for 1888 is a most creditable work, which reflects honor not only on its author, Professor Robert T. Hill, of the University of Texas, by far the best practical geologist who has ever studied Southern Arkansas and Texas, but also on Professor John C. Branner, the state geologist. The State of Arkansas must be complimented to have secured the services of such able observers.”

In the American Geologist for September, 1889, p. 156, he also gives me credit as being “The only American Geologist who has quoted my Mesozoic fossils of Texas.”* Later, however, after my second visit to Tucumcari Mesa, where and when I was the first to discover and there to announce the well-developed Cretaceous fauna identical with that of the uppermost Lower Cretaceous beds of Denison, Texas, he immediately directed his epithets at me, in articles elsewhere cited, in the American Geologist, the Proceedings of the Boston Society of Natural History, Science, and this Journal, each attack being proportionately more personal and bitter, as increasing research more and more conclusively demonstrated the Cretaceous age of his New Mexican “Jurassic,” and its stratigraphic position above the beds of Comet Creek which he, himself, had called Cretaceous.

I will admit that in the earlier years of my researches, when my papers were largely written in the field away from libraries, I have made occasional mistakes, (and who has not ?) some of which are typographic, others slips of the pen, and others merely mistakes, but these papers have always been conscientiously written with a desire to state the truth, and in every instance have been of material advancement to our knowledge of the stratigraphy of the Texas region, and Mr. Marcou’s insinuation, “not to use a stronger word,” that I have endeavored to corrupt the record is false. No amount of abuse, misrepresentation or misquotation on the part of Professor Marcou can alter the essential facts of research, nor cover up his own misstatement of fact and imperfect and misleading quotations. Even though he should succeed in his attempts to prove me untruthful and a defacer of the geologic record—which he cannot do—this would in no way excuse him for distorting and imperfectly quoting every new scientific discovery in order to uphold an erroneous and untenable deduction, founded on self-confessed incomplete exploration.

* In a subsequent paper in the American Geologist for August, 1894, p. 98, in which he makes his first change of front towards me, it is interesting to note that his principal unspecified allegation against me is that I do “not always give credit where credit is due.”

Finally, concerning his American geologic work, it can be said now, as was truthfully said by Professor Dana many years ago, that* “We cannot see, therefore, that Mr. Marcou’s claims as a discoverer are in any one case sustained, or that his merits are in any respect enhanced by his American researches, and we certainly should not go to him for an exposition of American geology.”† . . . “We cannot therefore think that his former reviewers and opponents deserve, because they differ from him, either to have their names expunged from American geological history, or thrown into discredit; nor do we believe that their reputations will seriously suffer from our ambitious Rocky Mountain explorer.‡ . . . Whoever may identify true Permian, true Triassic or true Jurassic strata will not have borrowed from Mr. Marcou and can owe him no credit.”§

* This Journal, Nov. 1858, and January 1859. † Ibid., January 1859, p. 139.
‡ Ibid., November 1858, p. 333. § Ibid., November 1858, p. 331.

SCIENTIFIC INTELLIGENCE.

I. CHEMISTRY AND PHYSICS.

1. *On Thermal Phenomena attending Change in Rotatory Power.*—It is well known that certain carbohydrates, at the moment of solution in water, show an abnormal circular polarization; and that optical stability in such solutions, at ordinary temperatures, is attained only very slowly. This phenomenon, which was first observed in dextrose and milk sugar, was called *birotation*, since it was believed that the circular polarization of the freshly prepared solution was twice that of the rotation finally reached. Subsequent investigations, however, have shown that even in these cases the ratio of the rotations is never exactly 2:1, and further, that dextrose and milk sugar are capable of existing transitorily in solution in more than two optical conditions; and this, coupled with the fact that the rotatory power of a freshly made solution of maltose is actually less than its subsequent value, has caused the term *multi-rotation* to be adopted as preferable. Now it has been observed that when a substance capable of showing this property is originally produced by the hydrolysis of another carbohydrate of greater molecular complexity, the phenomenon of multi-rotation also appears. And BROWN and PICKERING have sought to ascertain whether this change in optical properties is attended by any corresponding heat change. Three optically different forms of dextrose have been described by Tanret. His α -dextrose is the so-called birotatory substance, β -dextrose being the ordinary optically stable form. His γ -dextrose, produced by heating amorphous dextrose to 100° – 110° , has an abnormally low rotation when freshly dissolved. Since dextrose is produced by hydrolysis in the α form, the authors determined the heat change when this form was converted into β by adding 0.01 per cent of soda solution, the operation being conducted in a suitable calorimeter, and a check determination being made by using the dextrose in a second experiment, already in the β form. The corrected mean of four values is given as 0.588 calory per gram of substance. Plotting the heat changes thus obtained after various intervals of time and comparing the curve with that given by Parcus and Tollens for the rate of change of rotatory power, it appears that, while the heat curve is somewhat flatter, the general character of the two curves is the same. Thus making it probable that “the special physical or chemical changes which determine the gradual alteration or specific rotation in freshly prepared dextrose solutions proceed *pari passu* with the heat evolution,” and therefore “that this evolution is the result of the changes in question.” Similar experiments were made with maltose, with levulose and with milk sugar. No change of temperature was detected with the first, while levulose gave -4.64 calories per gram and milk sugar

+0.19 calories per gram. As to the cause of multi-rotation, the authors conclude that it is probably "an effect of chemical change brought about by the interaction of sugar and its solvent."—*J. Chem. Soc.*, lxxi, 756-783, July, 1897. G. F. B.

2. *On the Chemical Action of Electrical Oscillations.*—The chemical action of an oscillating electric field upon various substances has been studied by DE HEMPTINNE. His apparatus, which was a modification of that of Lecher, consisted of a pair of plate condensers, one side of each being connected with a Wimshurst machine, driven at a constant speed by a gas motor, an adjustable spark gap being placed between the two plates. The other coatings were connected to two wires of considerable length, terminating in two plates facing each other. Substances placed in the space between these plates are subjected to the influence of the oscillating discharge of the condensers, whose frequency and pressure may be varied at will. If a wire be placed across the two conductors at certain points, an illuminated vacuum tube between the plates becomes dark; while on shifting this wire along, points are reached at intervals where the tube again glows. The distances between these points, as Wiedemann and Ebert have shown, represent the wave length of the oscillation. When very high pressure was needed the author used a Tesla apparatus, the current of an alternating machine being transformed up one hundred fold. The secondary of this transformer was connected to a condenser, and, through a spark gap, with the primary of an induction coil; thus giving in the secondary of this coil, whose terminals ended in two plates opposite to one another, an oscillating discharge of high frequency and pressure. The gas to be examined was contained in a glass cylinder 4^{cm} broad and 12-13^{cm} long, having taps at its ends, the lower one terminating in a smaller and graduated tube dipping under mercury; so that the pressure in the cylinder was less than that of the atmosphere. It was observed that no action took place within the tube unless it became luminous. Moreover two tubes may screen each other; and if the pressure of the gas in the tubes be slightly different, then when they are placed between the plates and the discharge is so adjusted that only one glows, a slight increase of pressure in this tube causes it to become dark while the other one glows and is decomposed. The substances exposed to the action of the discharge were ammonia, carbon disulphide, glycerin, oxalic acid and calcium carbonate. It appeared that the speed of decomposition increased with increasing pressure, these pressures being 5, 15 and 50^{mm}; a maximum being reached soon after the decomposition began and then decreased. Moreover this speed is decidedly influenced by the energy of the discharge. The amount of the ammonia eventually decomposed varies with the pressure, being about 50 per cent at 49^{mm} and 95 per cent at 20^{mm}, though the values obtained do not agree with the expression $p_1 p_2^3 / p_3^2 = k$, which theory gives for dissociation by heat. Addition of nitrogen or hydrogen lowers the

decomposition, the former less than the latter. Mixed nitrogen and hydrogen when exposed to electric oscillations unite to the extent of 3 or 4 per cent, the result being apparently independent of the pressure. Carbon disulphide suffers decomposition in the oscillating field, the speed corresponding closely to the equation $dx/dt=k(a-x)$. Glycerin and oxalic acid show an increase of vapor-pressure in the oscillating field, but calcium carbonate appears unaffected.—*Zeitschr. phys. Chem.*, xxii, 360-372, April, 1897.

G. F. B.

3. *On the Explosion of Chlorine Peroxide with Carbon Monoxide.*—Experiments made a year or more ago by DIXON showed that when a mixture of well-dried carbon monoxide with other burning gases, such as cyanogen or carbon disulphide, was exploded, the carbon monoxide was not completely burned although there was more than enough oxygen for the combustion of both gases and the flame traversed the entire mixture. A suggestion of L. Meyer, that this result was due to the high stability of the oxygen molecule, was disproved by exploding a mixture of well-dried carbon monoxide, oxygen and ozone; which showed that a mixture containing 36 per cent of carbon monoxide and 8 per cent of ozone cannot be fired by a powerful electric spark. Moreover cyanogen is entirely burned to carbon dioxide when exploded with an excess of oxygen. And Smithells, in his flame separator, found that in the inner cone cyanogen is burned to carbon monoxide, this latter being burned completely in dried air when the outer and inner cones are close together, but being extinguished when they are considerably separated. Since it appears, therefore, that carbon monoxide is readily oxidizable when first formed, the author in conjunction with RUSSELL has examined the question whether oxygen when freshly produced would show the same activity toward carbon monoxide. For this purpose they exploded a well-dried mixture of carbon monoxide and chlorine peroxide. Since dry chlorine peroxide yields chlorine and oxygen when detonated, even with an inert gas, it is evident when it is fired in presence of carbon monoxide, this latter gas finds itself intimately mixed with highly heated "nascent" oxygen. The chlorine peroxide was prepared by the action of sulphuric acid diluted one-half with water, upon finely divided potassium chlorate, on a water bath; this gas as well as the carbon monoxide being allowed to pass simultaneously into a specially constructed eudiometer containing phosphoric oxide. The mixture was composed of 29 per cent of chlorine peroxide, 60 per cent of carbon monoxide and 11 per cent of oxygen. After drying for six days, a spark was passed and a pale blue flame traversed the tube. Analysis showed that the residue contained 29 per cent of carbon monoxide, nearly 50 per cent having remained unburned. After decanting the gas and allowing it to stand over potash solution, a spark exploded it violently. A second experiment resulted similarly. The authors therefore do not find "that oxygen just liberated from a compound is more active than

ordinary oxygen in attracting carbon monoxide at a high temperature."—*J. Chem. Soc.*, lxxi, 605-7, June, 1897. G. F. B.

4. *On the Absorption of Nitrogen by Carbon compounds under the influence of the Silent Electric Discharge.*—Experiments have been made by BERTHELOT in further elucidation of the phenomena which result when nitrogen is absorbed by benzene and similar bodies under the influence of the silent electric discharge. He finds that the rate of absorption is more rapid the more frequent the vibrations of the interrupter, a Marcel-Deprez contact-breaker giving better results than the Foucault interrupter even with or without specially high frequency. In the case of benzene he finds the maximum quantity of nitrogen absorbed is about 12 per cent of the mass of the benzene, the absorption being complete in presence of an excess of liquid. If the nitrogen be atmospheric, the absorption is not complete, though the residue is smaller than the quantity of argon present in the air, since a portion of the argon is absorbed. When the absorption is complete the ratio of benzene to nitrogen is $(C_6H_6)_3 : N_2$. The product in its empirical composition corresponds with diphenylphenylenediamine, and shows many properties common to diamines of this class, mixed with condensation products. When exposed to air or oxygen it readily oxidizes, though without setting free nitrogen; and when treated with hydrochloric acid yields salts the bases of which have odors recalling those of quinoline and the hydro-pyridines. When heated this hydrochloric acid product yields ammonium chloride. The original product when heated by itself gives off large quantities of ammonia, together with benzene, water (resulting from oxidation in the air), a trace of aniline and a bituminous liquid containing nitrogen. Heated in absence of air, it yields ammonia but no free nitrogen. When carbon disulphide is employed, the absorption is more rapid and is complete if the disulphide be in excess. The maximum quantity absorbed is 11.7 per cent of the mass of the bisulphide, the ratio being $(CS_2)_3 : N_2$ the same as with benzene. The product oxidizes in presence of oxygen, no nitrogen being set free. When heated out of contact with the air, some nitrogen is evolved, the larger part remaining in combination with the products of condensation, Hence these products are more stable than those formed by argon or helium. Thiophene under similar conditions absorbs about 8.6 per cent of its weight of nitrogen, the ratio in this case being $(C_4SH_4)_2 : N$.—*C. R.*, cxxiv, 528-532, March, 1897.

G. F. B.

5. *Manual of Qualitative Analysis.* By the late Dr. C. REMIGIUS FRESENIUS. Authorized Translation by HORACE L. WELLS, M.A. New Edition, thoroughly revised, from the Sixteenth German Edition, 8vo, pp. xviii, 748. New York, 1897 (John Wiley & Sons).—The Manuals of Fresenius have stood first in the world among books treating of Analytical Chemistry for nearly fifty years. From the notes on Qualitative Analysis, given to the press in 1841 while he was yet a student at Bonn, down to the

sixteenth edition of this admirable work issued as late as 1895, the author devoted himself untiringly to its improvement, never admitting anything into it without personal verification. It is now fourteen years since the last American edition was published; and since then two thoroughly revised German editions have appeared. By a piece of good fortune Professor Wells was induced to undertake the translation of the book for a new American edition, and good evidence of the accurate and painstaking care with which he has done his work is to be found throughout its pages. While following the original closely and therefore retaining the general form which has given to this Manual its wide reputation, the translator has been obliged to rewrite a large part of the previous edition and to have the whole work reset. In its present form consequently it represents the most accurate methods and the most recent results in qualitative analysis, especially in the chemistry of the rarer elements and the less commonly occurring compounds. No distinction, we notice, is made between the alkaloid termination and that of the glucoside; morphin and salicin terminating alike in *in*. The book will be warmly welcomed by American analysts not only for the great excellence of the original but also for the faithfulness with which it has been put into its English form. G. F. B.

6. *The delay in spark discharges.*—E. WARBURG concludes from his researches that in the ordinary spark discharge the air changes from a very good insulator into a relatively good conductor. In the delay period there is formed, under the influence of the electrostatic force, a very weak invisible electrical current which at the end of the delay period goes over into a visible spark discharge. The delay period continues a longer or shorter time according to the conditions of the electrode; whether they are moist or dry, whether they are under the influence of radiations (ultra-violet radiations—X-ray radiations) or not.—*Wied. Ann.*, No. 11, 1897, pp 385-395. J. T.

7. *Photoelectric relations of Fluorspar and of Selenium.*—Shortly after Hertz had discovered that ultra-violet light lowered the spark potential, E. Wiedemann and H. Ebert showed that this working of light was limited to the cathode. In regard to this phenomenon Prof. J. J. Thomson quotes a hypothesis of Helmholtz that different substances may possess the power of attracting electricity with different intensities—for instance, if a metal draws to itself positive electricity stronger than the surrounding dielectric does then the metal strives to charge itself positively. If the conductor is surrounded by air in its normal condition then it cannot charge itself, since no electricity can escape. All of these conditions are changed when the conductors are subjected to ultra-violet rays. Then enter the following: 1, separation of metallic particles from the conductors; 2, chemical changes in the gas in the neighborhood of the conductor, which break up the gas in such a manner that it can take a charge. According to the above

hypothesis Professor J. J. Thomson explains why metals which charge positively the strongest, also have the greatest sympathy for positive electricity and destroy negative charges to the greatest extent. It has been known that many spots on cubes of fluorspar become negatively charged by light. These, according to the above hypothesis, must possess a greater attraction for negative electricity than for positive, and it would be expected that under the influence of light a positive charge on them would be dissipated. G. C. SCHMIDT has undertaken a research to settle this point and he concludes that fluorspar always charges itself positively at the corners of the crystal and especially on fresh cleavages, and always negatively in the middle. At these places, which are strongest electrified positively in light, the negative electricity is the most quickly dissipated. The positions on fluorspar which are negatively electrified by light are also deprived of negative electricity. Selenium behaves in a similar manner, and the phenomena that bodies charge themselves under the influence of light and dissipate negative electricity are separate phenomena, which are not so closely related as has been supposed. The theory supported by Prof. J. J. Thomson, on the working of light on non-electrified and on negatively charged bodies, is not confirmed by this investigation.—*Wied. Ann.*, No. 11, 407-414.

J. T.

8. *On a magnetic method of showing metallic iron.*—William Duane has shown that the damping effect of a steady magnetic field on oscillating bodies is more delicate than any chemical analysis for the detection of traces of iron. He has extended his investigation to the effect of rotating magnetic fields and finds that in this case the method is even more sensitive than that formerly employed with the steady field.—*Wied. Ann.*, No. 11, 1897, p. 543.

J. T.

9. *On the spectra of certain stars.*—A series of observations have been carried on at Potsdam by VOGEL and WILSING having as their object the classification according to their spectra of stars falling in the first spectral class. In the case of one hundred stars the presence of cleveite gas in their atmosphere could be established (Class Ib); they formed a fourth part of all the stars of Class I which were observed.—*Sitzungsberichte d. K. Preuss. Akad. der Wiss.*, Berlin, Oct. 21.

10. *On the structure of the Cathode Light and the nature of the Lenard Rays.*—GOLDSTEIN shows that the so-called third layer of the cathode light consists of rays in straight lines which have their origin not on the surface of the cathode itself but from the rays of the second layer. The author explains the Lenard rays as due to diffusely reflected cathode rays.—*Sitzberichte d. K. Akad. Wiss.*, Berlin, Oct. 21.

11. *A new Nicol Prism.*—It is announced that C. Leiss has devised a new form of prism of Iceland spar and glass which permits of a saving of 50 per cent in the material.—*Sitz. d. K. Akad.*, Berlin, Oct. 21.

II. GEOLOGY AND NATURAL HISTORY.

1. *Observations on Baffinland.*—Dr. ROBERT BELL, F.R.S., of the Geological Survey of Canada, has recently returned from a five months trip into the northern regions. Having proceeded by the Dominion Government S. S. *Diana* to Hudson Strait, he took a yacht and small boat from there, and made a topographical and geological survey of about 300 miles of the southern coast of Baffinland. From an account in the "*Ottawa Citizen*" of October 27th we extract the following :

"The northern side of Hudson Strait is the southern coast of Baffinland, which is the third largest island in the world, being 1,100 miles in length. The island of Greenland and the island of Australia alone exceed it in length. Hudson Strait is about 500 miles in length, and averages about 100 miles in width. Big Island, which lies near the north side, is 30 miles long and about 20 miles wide. Both shores of the strait are mountainous, and destitute of trees, being beyond the limits of the northern forests. The land along the western half of the south shore is higher and bolder than any other part of these coasts, and rises to a height of between 1,000 and 2,000 feet above the sea. The eastern half of the south coast is rather low, and is not broken by any mountain range. Dr. Bell says : 'The whole north shore is rugged, but it rises more gradually as we go back from the sea, and attains a general elevation of 1,000 to 1,500 feet at a distance of 10 to 20 miles inland, although some parts are higher ; between Frobisher Bay and the eastern part of Hudson Strait, Grinnell glacier, an extensive sheet of ice covers this range, and may be seen from a long distance on a clear day, although one may often pass through Hudson Strait without observing it. In the spring a cold, ice-laden current, flowing in from Davis Strait, passes up the north side of Hudson Strait, while the warmer water of Hudson Bay flows out along the south shore. The north side has therefore a more Arctic character than the south.'"

"On the 20th of July, when Dr. Bell commenced his exploration, the south shore was comparatively free, while the north side had a cold, forbidding appearance. The 'ice-foot,' 20 to 30 feet thick, still adhered to the rocks, all along, except in some of the inlets. At the outset of his journey Dr. Bell was fortunate enough to find an Eskimo who knew the coast and at the same time understood English pretty well, having picked it up at Spicer's Trading Station, which had been maintained in this vicinity for several years.

"The greater part of the coast to be explored was so completely unknown that it was not indicated on the charts even by a dotted line. Passing to the northwest of Big Island, the mainland soon became fringed with many islands, and a little farther on the whole coast seemed to be broken up into innumerable mountainous islands of all sizes, from single hills of rock surrounded by water, to ranges several miles in length. This border of islands

would be from 10 to 20 miles in width. Indeed, it was difficult to know when the mainland was finally reached. Even then, when the explorers ascended a mountain they could see many channels of the sea running in all directions among the high hills. Besides the channels and those separating the islands, a number of large fjords running far inland were discovered and explored. These geographical conditions are due to the geological structure of a great development of crystalline rocks, their extensive erosion and partial submergence. Dr. Bell does not recall such a striking example of this kind of topography in any other part of the world. The northeast coast of Georgian Bay resembles it in some respects on a small scale, but here glaciation has reduced the general surface to a low level and a comparatively even outline."

He also explored inland at one point sufficiently far to locate two great lakes whose southern shores came within 50 or 60 miles of Hudson Strait. The party returned to St. John, N. B., in the latter part of October.

H. S. W.

2. *International Geological Congress.*—The International Geological Congress for 1897 took place at St. Petersburg from Aug. 28th to Oct. 5th and in point of view of attendance was the most successful yet held, several hundred geologists from all parts of the world being present and taking part. The session was opened by the honorary president, the Grand-Duke Constantine, and those portions of each day which were devoted to deliberations were divided among the different fields of geologic activity. It cannot be said that any large result followed immediately from these conferences but great moderation and caution were shown by the delegates and the exchange of views will undoubtedly be beneficial to geology in the future. The discussion of the question concerning stratigraphical nomenclature and classification resulted in a general understanding that it was yet too soon to decisively act upon this subject and in the meantime the historical method is recommended as being the most proper ground. In petrography practically the same result was arrived at, the petrographers declining to commit themselves at present to any definite classification but expressing the view that the science had progressed far enough at present to warrant the introduction of some simple group names to be used by the field geologist, and in mapping. The Congress recommended the establishment of an international station for the investigation of the sea bottom.

Dr. Hauchecorne and Dr. Beyschlag were placed in charge of the commission for the geological map of Europe. The invitation of the French geologists was accepted and Paris named as the place of meeting in 1900. A committee was appointed to report on the advisability and possibility of the establishment of an international journal devoted to the interests of petrography, especially for reviews.

A number of interesting exhibits were shown, among them that by the Imperial Geological Survey of Japan being, perhaps, the one that attracted the most attention.

A considerable number of American geologists were present, among them the venerable but active Prof. James Hall of Albany. The following were named vice-presidents: Prof. O. C. Marsh, Prof. B. K. Emerson, Mr. S. F. Emmons, Dr. Persifor Fraser.

The excursions both before and after the Congress were well attended and were managed with great ability and success considering the obstacles which in many cases had to be overcome in moving so large a number of people from point to point. Here the influence of the Russian government was clearly perceptible. Before the Congress the excursions were in Finland, Esthonia and to the Urals, and after it the excursion presented a choice of routes to the Caucasus and then through to Asia Minor and on the Black Sea, including the Crimea. It lasted upwards of a month. For these excursions, the members of the Congress were indebted to the Russian and Finnish governments for free transportation.

It would be well if in the future some plan could be devised by which these excursions could be strictly limited to those whom they are designed to benefit, and the alleged scientists, who join them for the sake of obtaining the advantage of cheap travel, could be cut off.

L. V. P.

3. *Mineral Resources of the United States, 1895*, DAVID T. DAY, Chief of Division (17th Ann. Report of the U. S. Geological Survey, Charles D. Walcott, Director). Washington, 1896.—The appearance of the seventeenth annual report of the United States Geological Survey has already been noticed in this Journal, but the two volumes on Mineral Resources of the United States in 1895 call for an additional remark. These volumes together form Part III of the complete report. This is the second time that the work on the mineral resources brought out by Mr. David T. Day has been published in this form.

The first of the two volumes is devoted to the metallic products and coal, the second to non-metallic products. They contain a valuable series of papers by various authors, of which the following may be mentioned among others: on iron ores by John Birkinbine; on copper and on lead by Charles Kirchhoff; on manganese, on coke and on petroleum by Joseph H. Weeks; on coal by Edward W. Parker; on stone by William C. Day. An interesting chapter by George F. Kunz is devoted to the precious stones of the country.

4. *A Descriptive Catalogue of Useful Fiber Plants of the World, including the structural and economic classifications of fibers*; by CHARLES RICHARDS DODGE, Special Agent, U. S. Department Agriculture. Washington, 1897.—It is doubtful whether the general public realizes the extent to which investigations bearing on economic development have been carried on, of late years, at the instance of the departments. The treatises are numerous and, for the most part, of excellent quality. The one before us is a case in point. Mr. Dodge has brought together in this convenient form a vast amount of information, much of

which he has apparently verified with his specimens in hand. The range of authorities laid under contribution is wide and has been thoroughly traversed by the author. We naturally expected to see in his list WIESNER'S *Die Rohstoffe des Pflanzenreiches*, and BARON VON MUELLER'S *Extratropical Plants*, but the other omissions which have come to notice are slight and unimportant. It seems a pity that this valuable compendium could not have been enriched by plates of the fibers themselves both in their commercial and ultimate reductions. But, even as it stands, it will set many a cultivator thinking in what way new fiber-plants can be obtained for experiment here. G. L. G.

II. MISCELLANEOUS SCIENTIFIC INTELLIGENCE.

1. *National Academy of Sciences*.—The autumn meeting of the National Academy of Sciences was held at Boston, beginning November 16. The following is a list of the papers accepted for reading:

- R. S. WOODWARD: The mass of the earth's atmosphere.
 - W. A. ROGERS: On a final determination of the relative lengths of the Imperial yard and of the meter of the International Bureau.
 - C. BARUS: The secular softening of cold hard steel.
 - T. C. MENDENHALL: On the elastic resistance of steel knife-edges.
 - A. HYATT: Evolution and migrations of land shells on Hawaiian islands.
 - R. H. CHITTENDEN: The influence of borax and boric acid on nutrition.
 - C. S. MINOT: Embryological observations.
 - IRA REMSEN: On a new method of obtaining derivatives of guanidine; On the boiling points of mixtures of benzine and alcohols; On double halides containing organic bases
 - A. A. MICHELSON and S. W. STRATTON: Results obtained with a new harmonic analyzer.
 - E. S. MORSE: On the ancient molluscan fauna of New England.
 - C. R. CROSS: On a new application of the wave siren.
 - C. L. NORTON: New apparatus for the comparison of thermometers and for the determinations of the heat of combustion of fuels.
 - O. C. MARSH: Recent observations on European Dinosaurs; The Jurassic formation of the Atlantic coast—Supplement
 - A. E. VERRILL: Ovarian variations and cannibalistic selection as factors in the evolution of species; Notable instances of free variation nearly unchecked by natural selection; Some of the important factors in the evolution of the marine animals of coral-reef seas.
 - S. C. CHANDLER: Comparison of the theory of the motion of the pole with recent observations.
 - J. W. POWELL: An hypothesis to account for movements in the crust of the earth.
 - S. WEIR MITCHELL and ALONZO H. STEWART: A contribution to the study of the action of the venom of the *Crotalus adamanteus* upon the blood.
 - S. F. EMMONS: Report on the international geological congress at St. Petersburg in August, 1897.
- A lecture was delivered by JOHN TROWBRIDGE at the Jeffersonian Physical Laboratory, Cambridge, on electrical discharges, with exhibition of apparatus for obtaining high voltages.

At the business meeting of the Academy on Nov. 17, it was announced that Miss Alice Bache Gould, daughter of the late Benjamin Apthorp Gould, had presented a sum of \$20,000, to be known

as the Benjamin Apthorp Gould fund, the proceeds of the fund to be used at the discretion of a board of three directors, two of whom must be members of the Academy, in furthering astronomical research. This fund was later formally accepted by the Academy; the following directors were appointed by Miss Gould: Prof. Lewis Boss of Albany, Dr. Seth C. Chandler of Cambridge and Prof. Asaph Hall of Washington.

2. *Cordoba Photographs*: Photographic Observations of Star-Clusters, from impressions made at the Argentine National Observatory, measured and computed by BENJAMIN APTHORP GOULD, Lynn, Mass., 1897.—The growing importance of astronomical photography is manifested in this extensive contribution to the subject, which completes the long array of results derived by Dr. Gould from his southern sojourn. It contains the results of the measurement of 177 plates, taken at Cordoba with an equatorial of $11\frac{1}{4}$ inches aperture, of which the original objective was that first devised and used by Rutherford, but having been broken on the journey to South America was replaced by a similar one by the same maker, Mr. Fitz. The objects photographed were mainly star-clusters and richer portions of the southern hemisphere, 37 districts being included in the present discussion, and some 27 yet remain to be computed. In all, the positions of 9144 stars are furnished, referred to 78 centers by polar coördinates; these are then converted into differences of right ascension and declination. For each plate four constants are determined by reference to known star-places, these being mainly derived from the Cordoba meridian observations. The four constants determined for each plate are the corrections to the rectangular coördinates of the origin and to the adopted scale-value and position-angle zero. This method seems amply adequate for the degree of accuracy aimed at, and the work will doubtless prove a most valuable addition to our knowledge of the southern heavens.

The volume is edited by Dr. S. C. Chandler, to whom this duty was confided after the death of Dr. Gould, who most lamentably was not to see the finished work, though the computations and discussion had all but completely passed through his hands.

W. L. E.

3. *November Meteors, 1897*.—A watch was kept at the Yale Observatory on the night of Saturday, Nov. 13, for 6 hours commencing at 11 p.m., by Mr. Brown (for one half of the time) and Mr. Smith, who exposed plates in the photographic apparatus. In all 30 meteors were seen during these hours, only 5 of which were conformable to the Leonid radiant. Only one of these fell in the area covered by the cameras and this was not bright enough to impress on the plates, which were much fogged by the moon, then only $4\frac{1}{2}$ days past full. The nights of Nov. 14, 15 and 16 were completely overcast here at New Haven.

W. L. E.

4. *Sixteenth Annual Report of the Bureau of American Ethnology* to the Secretary of the Smithsonian Institution, 1894-95; by J. W. POWELL, Director, 326 pp., with 81 plates and 83 figures in the text. Washington, 1897.—The sixteenth annual

report has been recently distributed to the public, and like those which have preceded, it gives evidence of the activity in this department and of the excellent work that is being done in the study of the many ethnological problems of this country. After the administrative report of the director, the following papers are given: Primitive Trephining in Peru, by M. A. Muñiz and W. J. McGee; Cliff Ruins of Canyon de Chelly, Arizona, by C. Mindeleff; Day Symbols of the Maya Year, by Cyrus Thomas; Tusayan Snake Ceremonies, by J. W. Fewkes.

5. *Field Columbian Museum*.—Recent publications of the Field Columbian Museum at Chicago include the following:

Publication 16. Anthropological Series. Vol. i, No. 1. Archaeological Studies among the Ancient Cities of Mexico. Part II, Monuments of Chiapas, Oaxaca and the Valley of Mexico. By William H. Holmes. 338 pp. This is a valuable contribution to a highly interesting subject. It is profusely illustrated, containing with other plates numerous panoramic views which the author has drawn with his well-known skill.

Publications 19 and 20. Zoölogical Series. Vol. i, Nos. 6 and 7. List of Mammals from Somali-Land obtained by the Museum's East African Expedition, and Remarks upon two Species of Deer of the Genus *Cervus*, from the Philippine Archipelago, by D. G. Elliot, F.R.S.E. 155 pp. (Plates.)

Publication 21. Anthropological Series. Vol. ii, No. 1. Observations on a Collection of Papuan Crania, by George A. Dorsey. With Notes on Preservation and Decorative Features, by William H. Holmes. 49 pp.

6. *The American Journal of Physiology*.—Attention is called to the following circular, which gives the prospectus of a new journal in a field not yet occupied in this country. It deserves the hearty support of all interested in the department.

The number of investigations in physiology and its allied sciences now made in this country is grown so large that the present means of publication are no longer sufficient. To meet the needs of investigators in physiology, physiological chemistry, physiological pharmacology, and certain other branches of biology, a special journal will be published, the first number appearing in January, 1898. The *American Journal of Physiology*, as the new publication will be called, will contain in each volume about five hundred pages, divided into parts or numbers, to be issued whenever material is received. It is expected that not more than one volume a year will be printed. The Journal will be edited for the American Physiological Society by H. P. Bowditch, M.D., Boston; R. H. Chittenden, Ph.D., New Haven; W. H. Howell, M.D., Baltimore; Frederic S. Lee, Ph.D., New York; Jacques Loeb, M.D., Chicago; W. P. Lombard, M.D., Ann Arbor; and W. T. Porter, M.D., Boston.

It is not to be supposed that a journal devoted solely to the publication of original researches in physiology will ever do more than pay for its paper and printing, and it is probable that some years must pass before the new enterprise will cease to be a financial burden on a small number of investigators. Yet the need of such a publication is undoubted. The aid of all friends of learning is asked until the Journal shall be established on a self-supporting basis. The subscription price, which is five dollars (£1 1s.; marks, 21; francs, 26) per volume, should be sent to W. T. Porter, M.D., 688 Boylston Street, Boston, Mass.

INDEX TO VOLUME IV.*

A

- Academy of Sciences, meeting at Boston, 479.
 Action at a distance, Drude, 390.
 Adams, G. I., extinct Felidæ, 145.
 Alabama geol. survey, 393.
 Allen, E. T., native iron in coal measures of Missouri, 99.
 American Microscopical Society, transactions, 256.
 Association, American, meeting at Detroit, 160, 250.
 British, meeting at Toronto, 324.
 Audition, limits of, Rayleigh, 69.

B

- Baffinland, observations, Bell, 476.
 Bancroft, W. D., The Phase Rule, 67.
 Barbour, on Dæmonelix, 77.
 Becker, G. F., fractional crystallization of rocks, 257.
 Bell, R., observations on Baffinland, 476.
 Birds of Colorado, Cooke, 326.
BOTANY—
 Cyperaceæ, studies in, Holm, No. V, 13; No. VI, 298.
 Plants, catalogue of useful fiber, Dodge, 478.
 Flora of North America, Synoptical, Vol. i, pt. I, 249; Britton and Brown, 250.
 Phænogamia, new system of classification, van Tieghem, 79.
 Branner, J. C., extension of the Appalachians across Mississippi, etc., 357.
 Brazil, Bendegó Meteorite, 159.
 Britton, N. L., Flora of N. United States, 250.
 Brown, A., Flora of N. United States, 250.

C

- Calculus for Engineers, Perry, 398.
 Canada geol. survey, 78, 394.
 Cape of Good Hope, geological commission, 1896, 395.

Cathode light and the nature of the Lenard rays, 475.
 rays, 71; Thomson, 391. See Röntgen rays.

CHEMISTRY—

- Aluminum and beryllium, separation, Havens, 111.
 Chlorine peroxide, explosion with carbon monoxide, Dixon, 472.
 Combustion of organic substances in the wet way, Phelps, 372.
 Cyanogen, spark spectrum, Hartley, 388.
 Dalton's law for solutions, Wildermann, 387.
 Double salts, Van't Hoff, 68.
 Electric discharge, synthetic action of dark, Losanitsch and Jovitschitsch, 66.
 Electrical oscillations, chemical action, Hemptinne, 471.
 Electrolytic solution and deposition of carbon, Coehn, 389.
 Electrosynthesis, Mixer, 51.
 Fluorine, liquefaction, Moissan and Dewar, 318.
 Gaseous elements, specific heat of, Berthelot, 65.
 Helium, action of silent electric discharge on, Berthelot, 152.
 Inorganic compounds, structural isomerism, Sabanéeff, 66.
 Nitrates into cyanides, conversion of, Kerp, 390.
 Nitrogen, absorption by carbon compounds, Berthelot, 473.
 Petroleum, normal and iso-pentane from America, Young and Thomas, 319.
 Potassium and sodium vapor, action in coloring their haloid salts, Giesel, 152.
 Properties of highly purified substances, Shenstone, 317.
 Qualitative Analysis, Manual, Fresenius and Wells, 474.
 Silicon, spectrum of, de Gramont, 388.
 Sodium thiosulphate, titration with iodic acid, Walker, 235.
 Supersaturation and supercooling, Ostwald, 151.

* This Index contains the general heads, BOTANY, CHEMISTRY (incl. chem. physics), GEOLOGY, MINERALS, OBITARY, ROCKS, and under each the titles of Articles referring thereto are mentioned.

CHEMISTRY—

- Thermal phenomena attending change in rotatory power, Brown and Pickering, 470.
 Thermochemical method for determining the equivalents of acids, Berthelot, 151.
 Viscosity of mixtures of miscible liquids, Thorpe and Rodger, 65.
 Cooke, W. W., Birds of Colorado, 326.
 Cooley, L. C., Physics, 390.
 Cordoba Photographs, Gould, 480.
 Cross, W., igneous rocks in Wyoming, 115.

D

- Dæmonelix, papers on, 77.
 Das Tierreich, Hartert, 250.
 Davenport, C. B., Experimental Morphology, 397.
 Derby, O. A., Bendegó meteorite, 159.
 Diamond, genesis and matrix of, Lewis and Bonney, 77.
 Dodge, C. R., catalogue of useful fiber plants, 478.

E

- Eastman, C. R., Ctenacanthus spines from the Keokuk limestone of Iowa, 10; Tamiobatis vetustus, 85.
 Ebonite, transparency, Perrigot, 72.
 Electrical convection of dissolved substances, Picton and Linder, 150.
 discharges in air, Trowbridge, 190.
 measurements by alternating currents, Rowland, 429.
 tension at the poles of an induction apparatus, Oberbeck, 391.
 Electricity and Magnetism, Webster, 72.
 Electrosynthesis, Mixer, 51.
 Elkin, W. L., November meteors, 480.
 Ethnology, 16th Ann. Report of Amer. Bureau of, 480.

F

- Fairbanks, H. W., contact metamorphism, 36; tin deposits at Temescal, So. California, 39.
 Field Columbian Museum, Publications, 481.
 Flames, theory of singing, Gill, 177.
 Foote, H. W., bixbyite and topaz, 105; composition of ilmenite, 108.
 Fossil, see GEOLOGY.
 Frog's Egg, Development, Morgan, 161.

- Franklin, W. S., Light and Sound, 73.
 Frenzel, A., identity of chalcostibite, etc., from Bolivia, 27.
 Fresenius, C. R., Manual of Qualitative Analysis, 473.

G

- Geological Congress, International, 477.
 lectures, Harvard University, Reusch, 397.
 GEOLOGICAL REPORTS AND SURVEYS—
 Alabama, 393.
 Canada, Hoffmann, 78, 394.
 Cape of Good Hope, 1896, 395.
 Indiana, annual report, 1896, 394.
 United States, 17th Annual Report, etc., 155; recent publications, 392.

GEOLOGY—

- Apodidæ, revision, Schuchert, 325.
 Appalachians, extension across Mississippi, etc., Branner, 357.
 Comanche series in Oklahoma and Kansas, Vaughan, 43.
 Crangopsis vermiformis of Kentucky, Ortmann, 283.
 Ctenacanthus spines from the Keokuk limestone of Iowa, Eastman, 10.
 Currituck Sound, Virginia and No. Carolina, Wieland, 76.
 Deposits from borings in the Nile Delta, Judd, 74.
 Dinosaurs, European, Marsh, 413.
 Eopaleozoic hot springs and siliceous oölite, Wieland, 262.
 Felidæ, extinct, Adams, 145.
 Florencia formation, Hershey, 90.
 Fossil insects of New Brunswick, Matthew, 394.
 Glacial observations in Greenland, Barton, 395.
 Glaciation in Greenland, Tarr, 325.
 Glaciers, Arctic, variation in length, Rabot, 395.
 Igneous rocks in Wyoming, Cross, 115.
 Jura and Neocomian of Arkansas, etc., Marcou, 197; 449.
 Jurassic of Texas, alleged, Hill, 449.
 Linuparus atavus of Dakota, Ortmann, 290.
 Metamorphism, contact, Fairbanks, 36.
 Patagonia, geology of southern, Hatcher, 246, 327; large oysters, Ortmann, 355.
 Peat in the Dismal Swamp, depth of, Wieland, 76.

GEOLOGY—

- Pithecanthropus erectus, Manouvrier, 213.
 Pleistocene deposits of Chicago area, Leverett, 157.
 Popocatepetl and Ixtaccihuatl, observations, Farrington, 326.
 Pre-glacial drainage in Michigan, Mudge, 383.
 Protoceratidæ, principal characters, Marsh, 165.
 Pseudoscorpion, a new fossil, Geinitz, 158.
 Rocks, fractional crystallization, Becker, 257.
 Stylolites, Hopkins, 142.
 Tamiobatis vetustus, Eastman, 85. See also ROCKS.
 Gill, H. V., theory of singing flames, 177.
 Glaciers, see GEOLOGY.
 Gould, B. A., Cordoba Photographs, 480.
 Gray Herbarium of Harvard University, Contributions, No. XI, Greenman, 249.

H

- Hallock, underground temperatures, 76.
 Hatcher, J. B., geology of southern Patagonia, 246, 327.
 Havens, F. S., aluminum and beryllium, separation, 111.
 Heat of combustion, Mendeléeff, 319.
 Heliostat, Mayer, 306.
 Hershey, O. H., Florencia formation, 90.
 Hill, R. T., alleged Jurassic of Texas, reply to Marcou, 449.
 Hoffmann, Canadian Mineralogy, 78.
 Holm, T., studies in the Cyperaceæ, V, 13; VI, 298.
 Hopkins, T. C., stylolites, 142.
 Hovey, H. C., Mammoth Cave of Kentucky, 326.

I

- Indiana, annual report of department of geology, 1896, 394.
 Induction coil, Wright, 324.

J

- Jaggard, T. A., Jr., microsclerometer for determining the hardness of minerals, 399.
 Judd, J. W., deposits from borings in the Nile Delta, 74.

K

- Kunz, G. F., sapphires from Montana, 417.

L

- Lenard rays, des Coudres, 391.
 Leverett, F., Pleistocene features and deposits of the Chicago area, 157.
 Lewis, H. Carvill, Genesis of the Diamond, 77.
 Light and Sound, Nichols and Franklin, 73.
 Linck, G., relation between the geometric constants and the molecular weight of a crystal, 321.
 Lindgren, W., monazite from Idaho, 63.
 Lodge, O., influence of a magnetic field on radiation-frequency, 153.

M

- MacCurdy, George Grant, translation of paper on Pithecanthropus erectus, 213.
 Magnetic field, influence on radiation-frequency, Lodge, 153.
 method of showing metallic iron, Duane, 475.
 Mammoth Cave of Kentucky, Hovey and Call, 326.
 Manouvrier, L., Pithecanthropus erectus, 213.
 Marcou, J., Jura and Neocomian of Arkansas, etc., 197; Reply to, R. T. Hill, 449.
 Marsh, O. C., principal characters of the Protoceratidæ, 165; observations on European Dinosaurs, 413.
 Mayer, A. G., improved heliostat of A. M. Mayer, 306.
 Mercury resistance, pressure coefficient of, Palmer, 1.
 Metals, capillary constants of molten, Siedentopf, 320.
 Meteorite, Bendegó, Derby, 159.
 iron, new, Canada, 325.
 Meteors, November, 480.
 Microsclerometer for determining hardness of minerals, Jaggard, 399.
 Mineral Resources of the United States, Day, 478.
 MINERALS.—
 Altaite, British Columbia, 78.
 Bertrandite, Maine, 316. Bismutomalite, 159. Bixbyite, Utah, 105.

MINERALS—

- Cassiterite in California, 39. Chalcostibite, Bolivia, 31. Corundum, Montana, 417; 421, 424.
 Danaite, British Columbia, 78. Diamond, So. Africa, 77. Dicksonbergite, Sweden, 158.
 Fluorite, 474.
 Fuggerite, 159.
 Guejarite, 27.
 Hamlinite, Maine, 313.
 Ilmenite, composition, 108. Iron, native, Missouri, 99.
 Leonite, 158. Leucite, Wyoming, 115.
 Maltesite, Finland, 158. Manganandalusite, Sweden, 158. Mica pseudomorphs, 309. Monazite, Idaho, 63. Munkforsite, Sweden, 159.
 Nitre, 118.
 Pyroxene pseudomorph, 309.
 Quirogite, 158.
 Sapphires, Montana, 417, 421, 424. Scheelite, Nova Scotia, 78. Stromeyerite, British Columbia, 78.
 Tetradymite, British Columbia, 78. Topaz, Utah, 107.
 Wolfsbergite, 27.
 Minerals, determination of hardness of, Jagger, 399.
 Mixer, W. G., electrosynthesis, 51.
 Morgan, T. H., Development of the Frog's Egg, 161.
 Morphology, Experimental, Davenport, 397.
 Mudge, pre-glacial drainage in Michigan, 383.

N

- Nichols, E. L., Light and Sound, 73.
 Nicol prism, new, Leiss, 475.
 Nile delta, deposits of, Judd, 74.

O

OBITUARY—

- Clark, A. G., 83.
 Des Cloizeaux, A., 164.
 Fresenius, C. R., 84.
 Mayer, A. M., 161.
 Meyer, V., 398.
 Sachs, J., 164.
 Orthoptera, North America, Scudder, 250.
 Ortman, A. E., Crangopsis vermiformis of Kentucky, 283; Linuparus atavus of Dakota, 290; large oysters of Patagonia, 355.

- Oscillatory currents, Seiler, 71.
 discharge of a large accumulator, Trowbridge, 194.
 Ostwald, supersaturation, etc., 151.
 Ostwald's Klassiker der Exacten Wissenschaften, 398.
 Oysters of Patagonia, Ortman, 355.

P

- Palmer A. deF., Jr., pressure coefficient of mercury resistance, 1.
 Patagonia, geology of, 247, 327, 355.
 Penfield, S. L., identity of chalcostibite, etc., from Bolivia, 27; bixbyite and topaz, 105; composition of ilmenite, 108; chemical composition of hamlinite, 313.
 Perry, J., Calculus for Engineers, 398.
 Phase Rule, Bancroft, 67.
 Phelps I. K., combustion of organic substances in the wet way, 372.
 Photoelectric relations of fluorspar and selenium, Schmidt, 474.
 Physics, Cooley, 390; Elements, Nichols and Franklin, 73.
 Physiology, American Journal of, 481.
 Pirsson, L. V., corundum-bearing rock from Montana, 421.
 Polarization capacity, Gordon, 71.
 Pratt, J. H., crystallography of Montana sapphires, 424.
 Prinz, W., Esquisses Sélénologiques II., 396.
 Pseudomorphs from New York, Smyth, 309.

R

- Rabot, C., variations in length of Arctic glaciers, 395.
 Rarified gases, behavior of, Ebert and Wiedeman, 391.
 Rayleigh, limits of audition, 69.
 Resistance of mercury, pressure-coefficient, Palmer, 1.
 Robb, W. L., solarization effects on Röntgen ray photographs, 243.
 Röntgen rays, in surgery, 72.
 photographs, solarization effects, Robb, 243.
 See Cathode rays.
 Rowland, H. A., electrical measurement by alternating currents, 429.
 Rocks—
 Fractional crystallization of rocks, Becker, 257.

Rocks—

- Corundum-bearing rock from Montana, 421.
 Leucite rocks in Wyoming, 115.
 Madupite, 129.
 Orendite, Wyoming, 123.
 Wyomingite, 120.

S

- Scudder, S. H., North American Orthoptera, 250.
 Secondary undulations registered on tide gauges, Denison, 82.
 Smyth, C. H. Jr., pseudomorphs from New York, 309.
 Spark discharges, Warburg, 474.
 Specific heat, determination by the method of mixtures, Wadsworth, 265.
 Stars, spectra of certain, Vogel and Wilsing, 475.
 South Africa Geological Society, vol. II, 78.

T

- Temperatures, underground, at great depths, Hallock, 76.
 Tide gauge observations, 82.
 Tin deposits, Temescal, So. California, 39.
 Trowbridge, J., electrical discharges in air, 190; oscillatory discharge of a large accumulator, 194.

U

- United States Geological Survey, publications, 155, 392.

V

- Van Tieghem, new system of classification of phænogamia, 79.
 Van't Hoff, Doppelsalzen, etc., 68.
 Vaughan, T. W., outlying areas of the Comanche series, 43.

W

- Wadsworth, F. L. O., determination of specific heat by the method of mixtures, 265.
 Walker, C. F., titration of sodium thiosulphate with iodic acid, 235.
 Wave-length, effect of pressure on, Humphreys, 392.
 Webster, A. G., Theory of Electricity and Magnetism, 72.
 Wells, H. L., translation of Fresenius's Qualitative Analysis, 473.
 Wieland, G. R., Currituck Sound, Virginia and North Carolina, 76; depth of peat in the Dismal Swamp, 76; eopaleozoic hot springs and siliceous oölite, 262.
 Wright, L., Induction Coil in practical work, 324.

Z

- Zoological Bulletin, 83.



TAMIOBATIS VETUSTUS.

Dorsal aspect of cranium, two-thirds natural size. From a photograph taken by Dr. T. A. Jaggard, Jr.



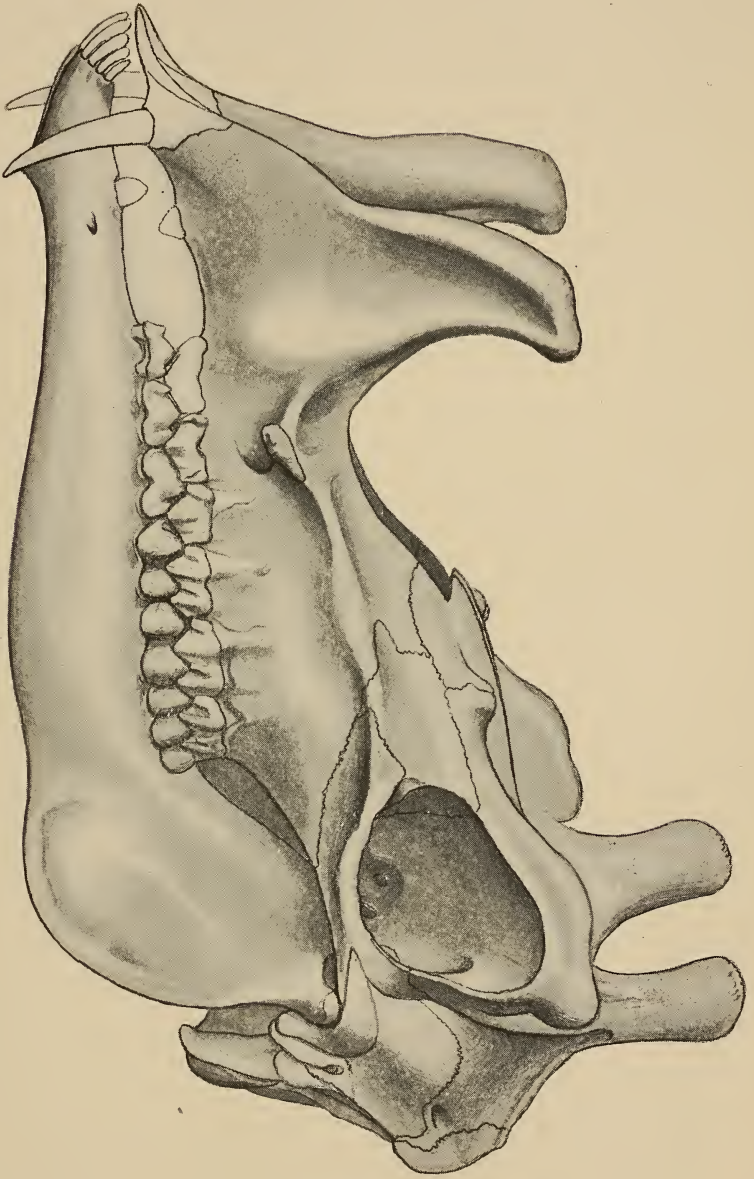

Male skull of *PROTOPHERAS CELER*, Marsh. Miocene.
Three-fourths natural size.

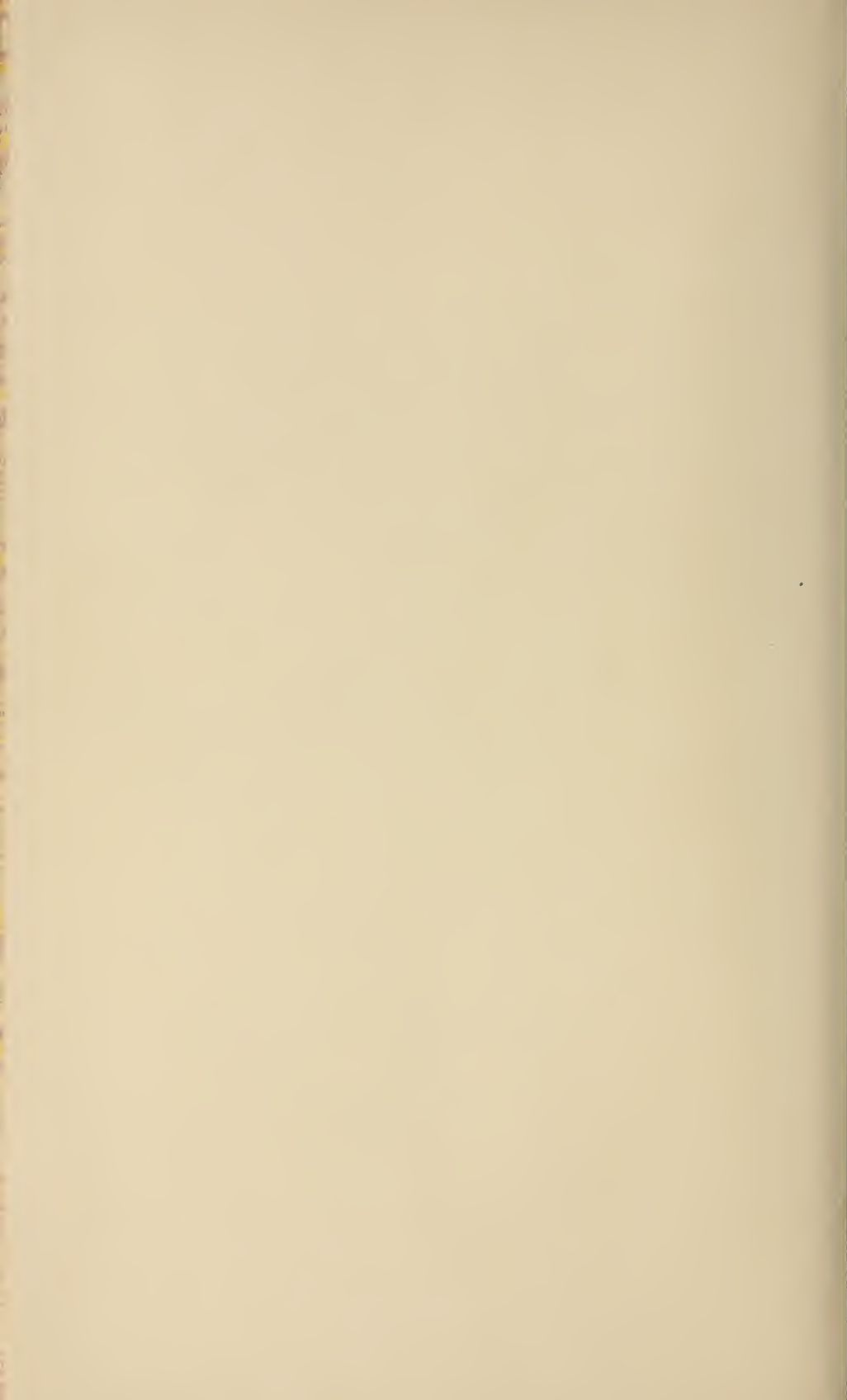

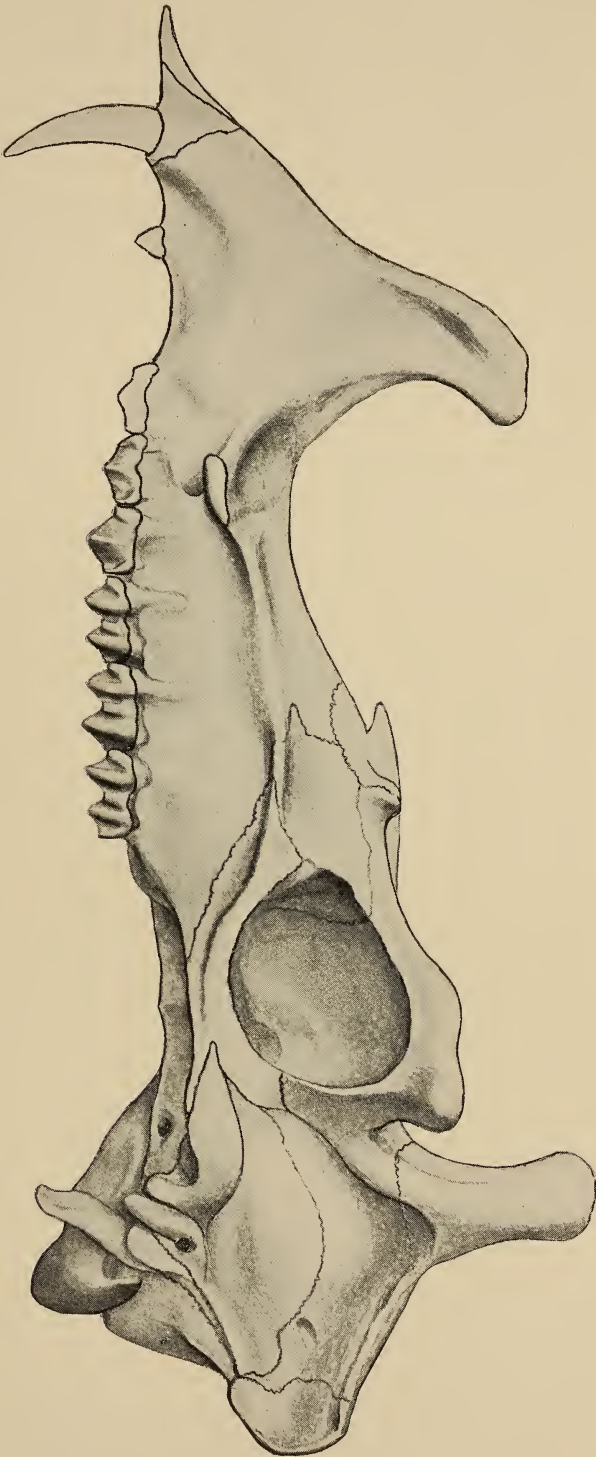

Male skull of *PROTOCERAS CETER*. Miocene.
Three-fourths natural size.





Male skull of *PROTOCERAS CELER*. Miocene.
Three-fourths natural size.

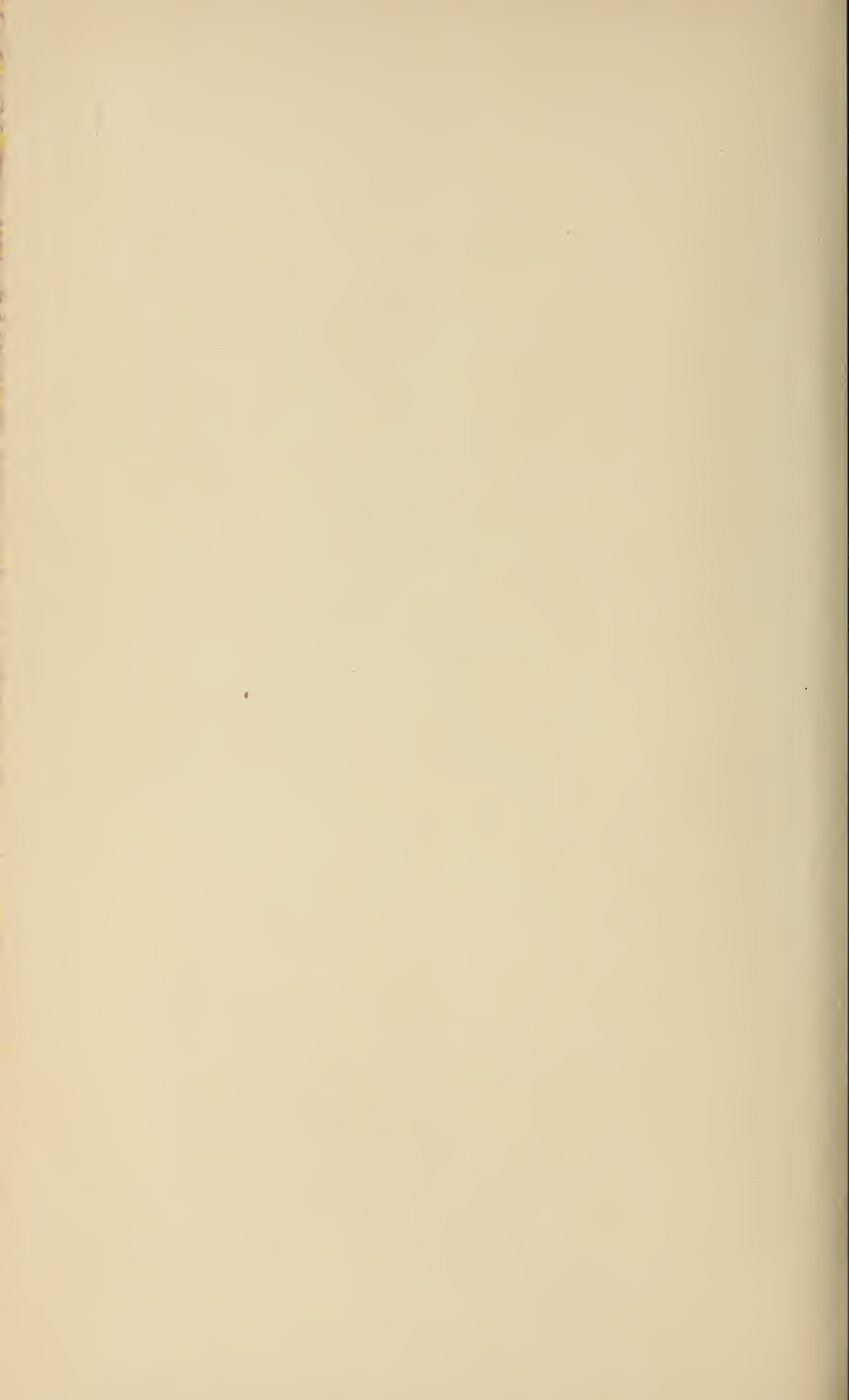

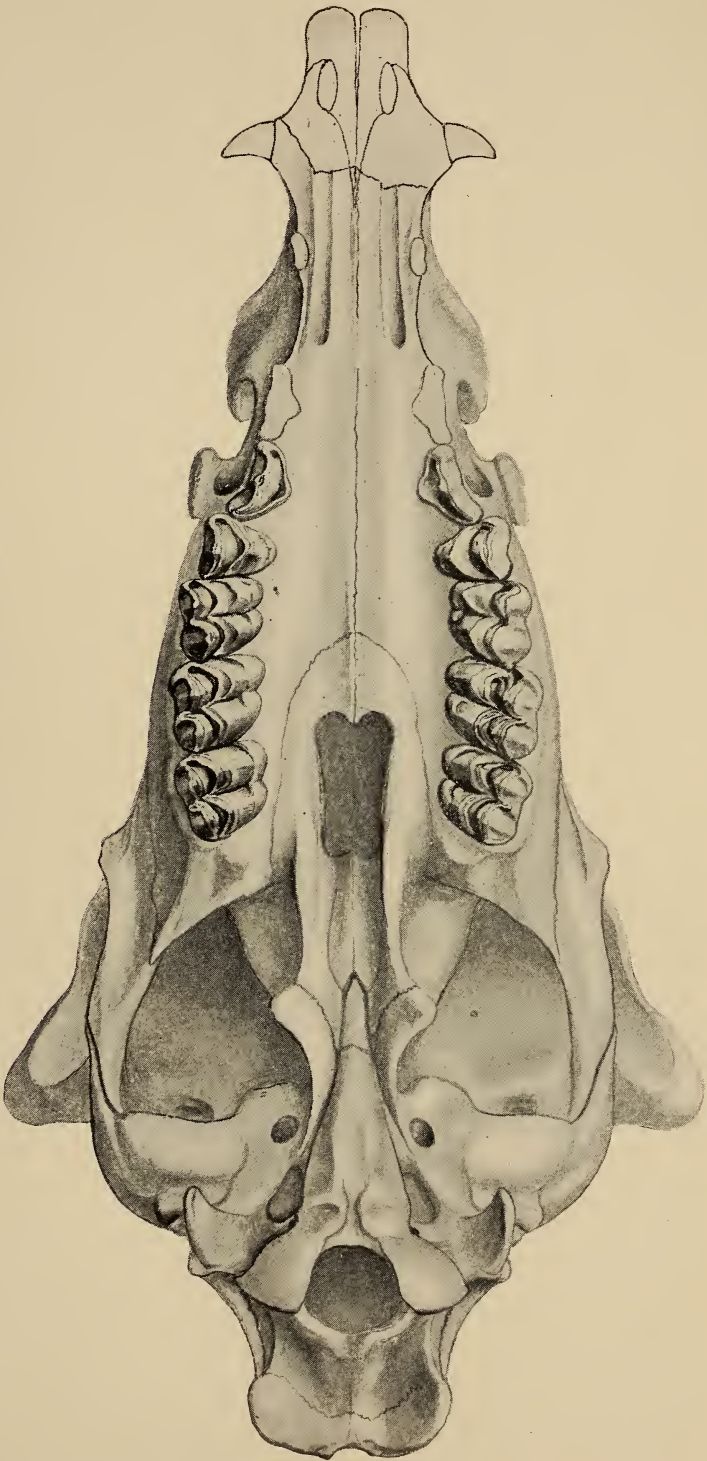

Male skull of *PROTOCERAS CELER*. Miocene.
Three-fourths natural size.



1.



2.

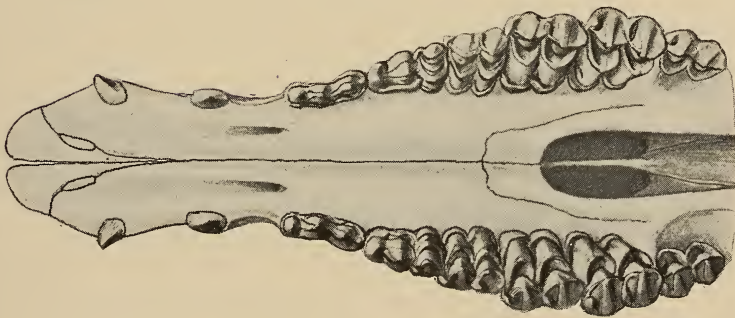

1.—Male skull of *PROTOCERAS CELER*. Miocene.
2.—Female skull of *PROTOCERAS COMPTUS*, Marsh. Miocene.

Three-fourths natural size.



1.

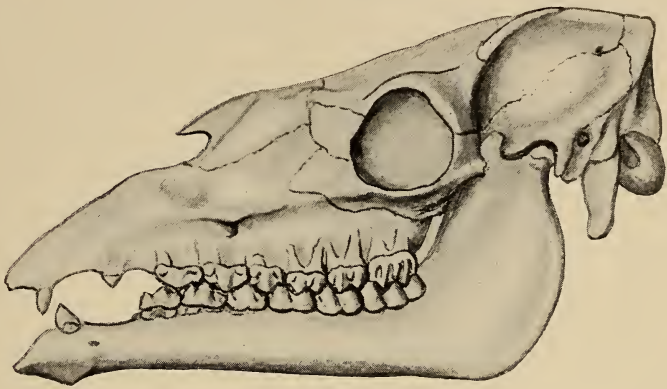

2.

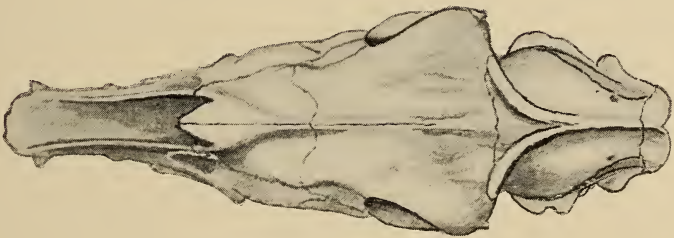

3.

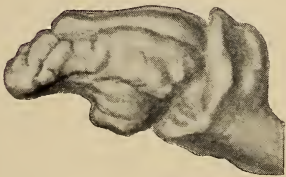

4.



1 and 2.—Female skull of *CALOPS CONSORS*, Marsh. Miocene.
3 and 4.—Brain cast of *PROTOCERAS CELER*. Miocene.

One-half natural size.



1.



2.

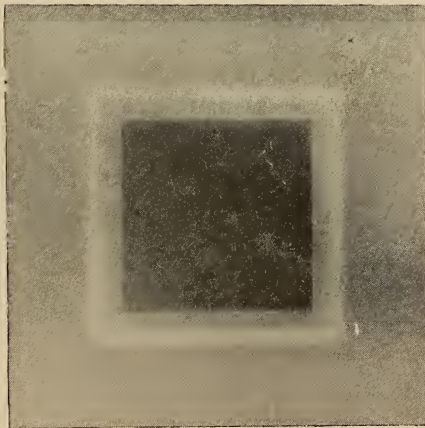



1.

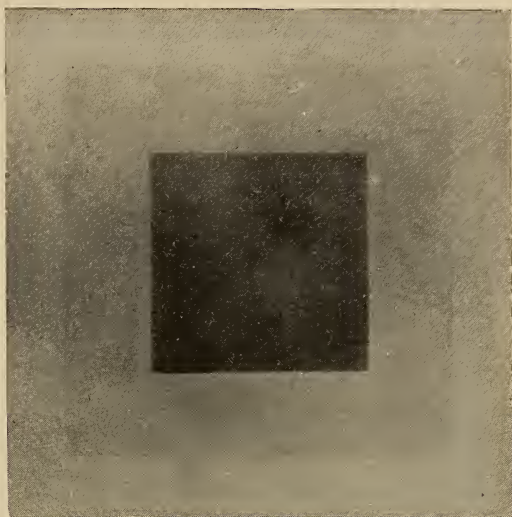

2.

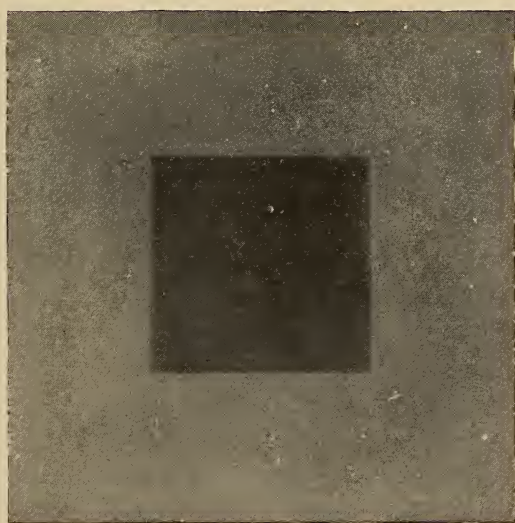

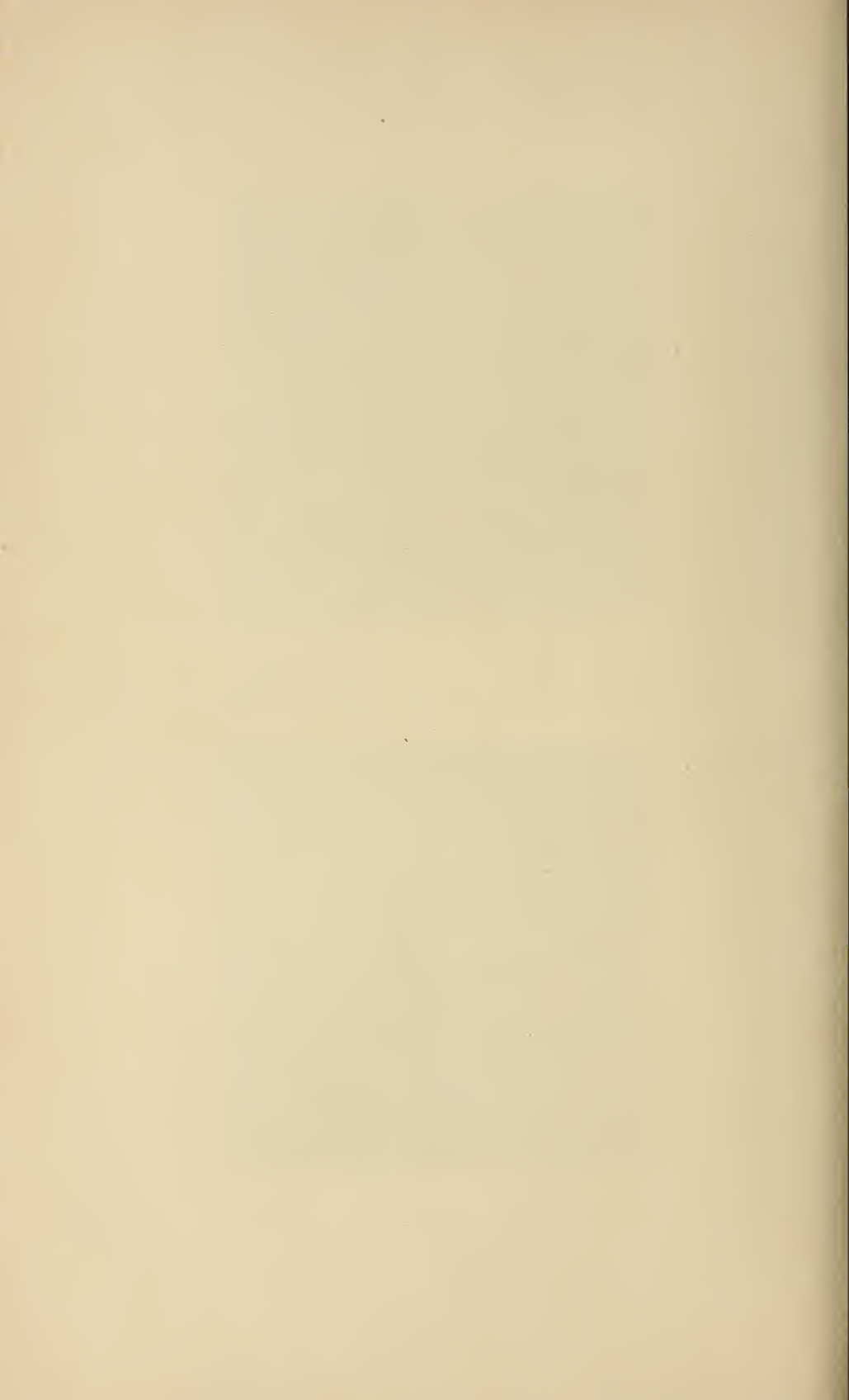

1.

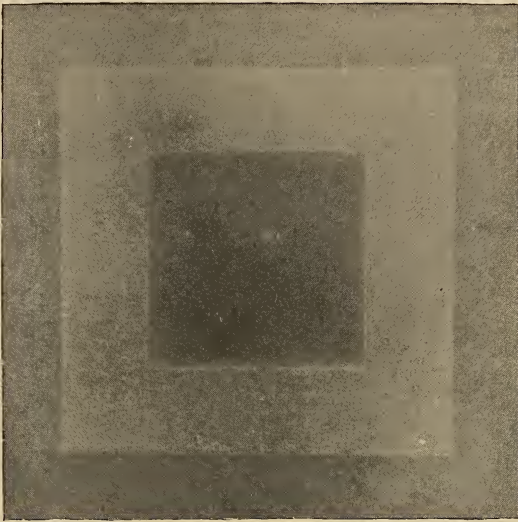

2.

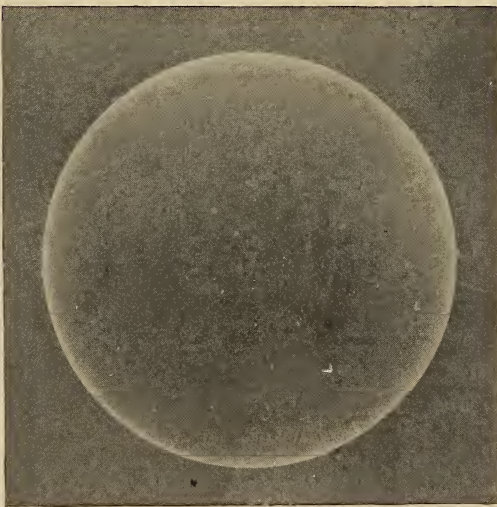



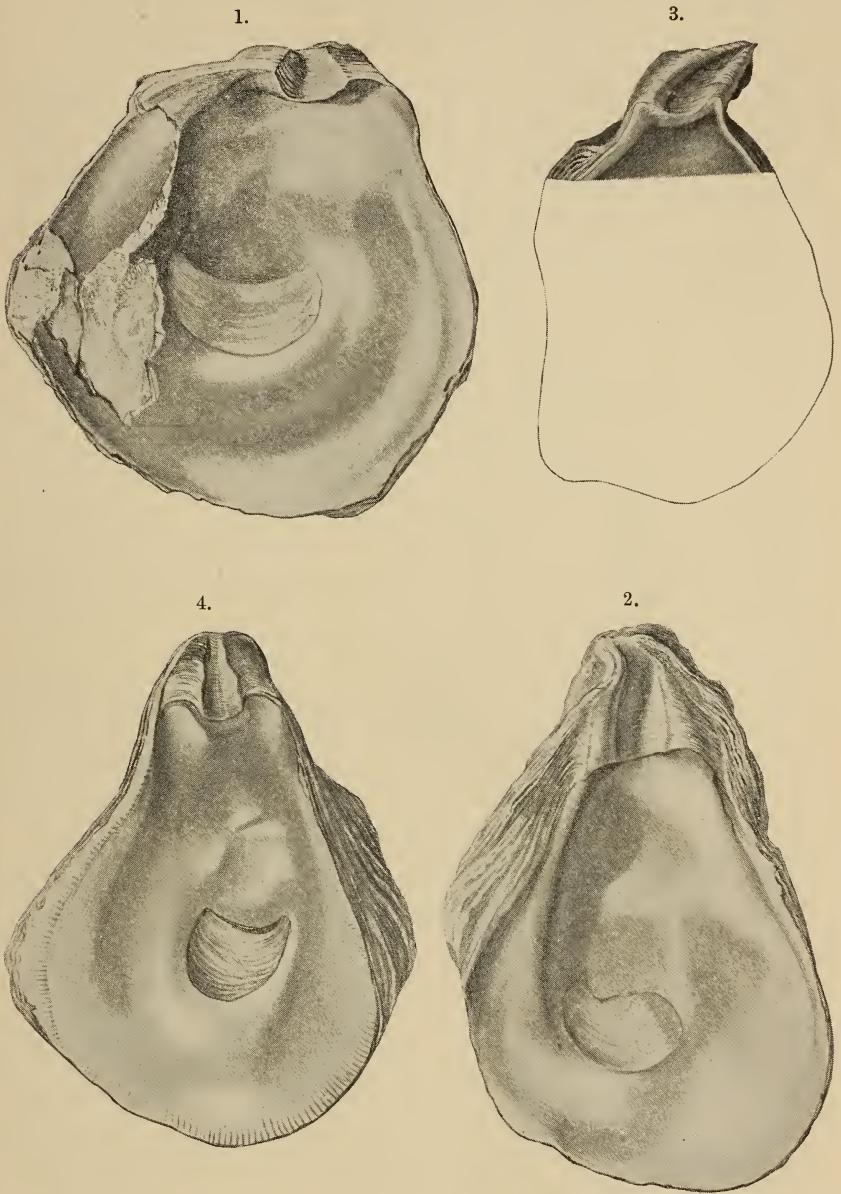
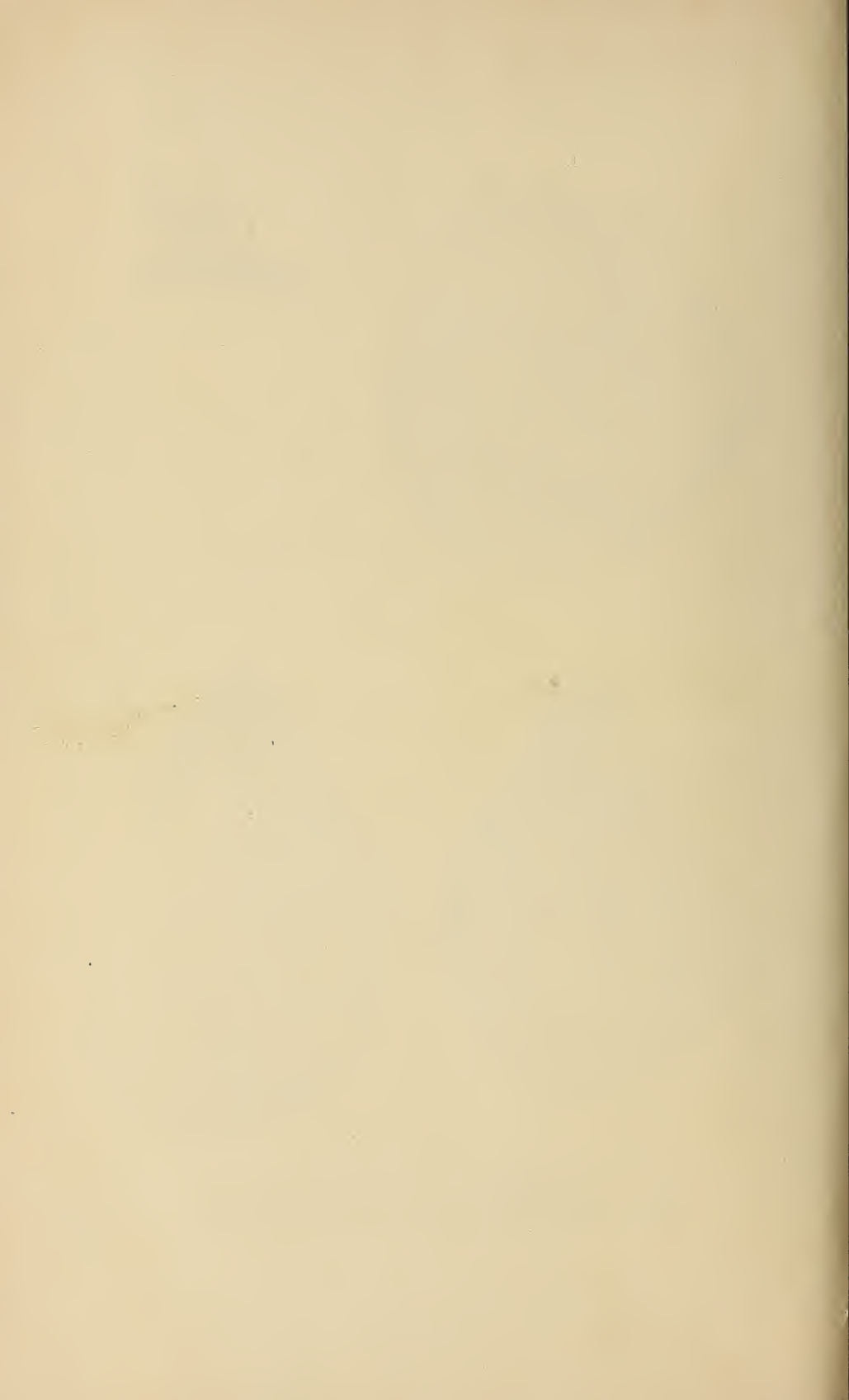
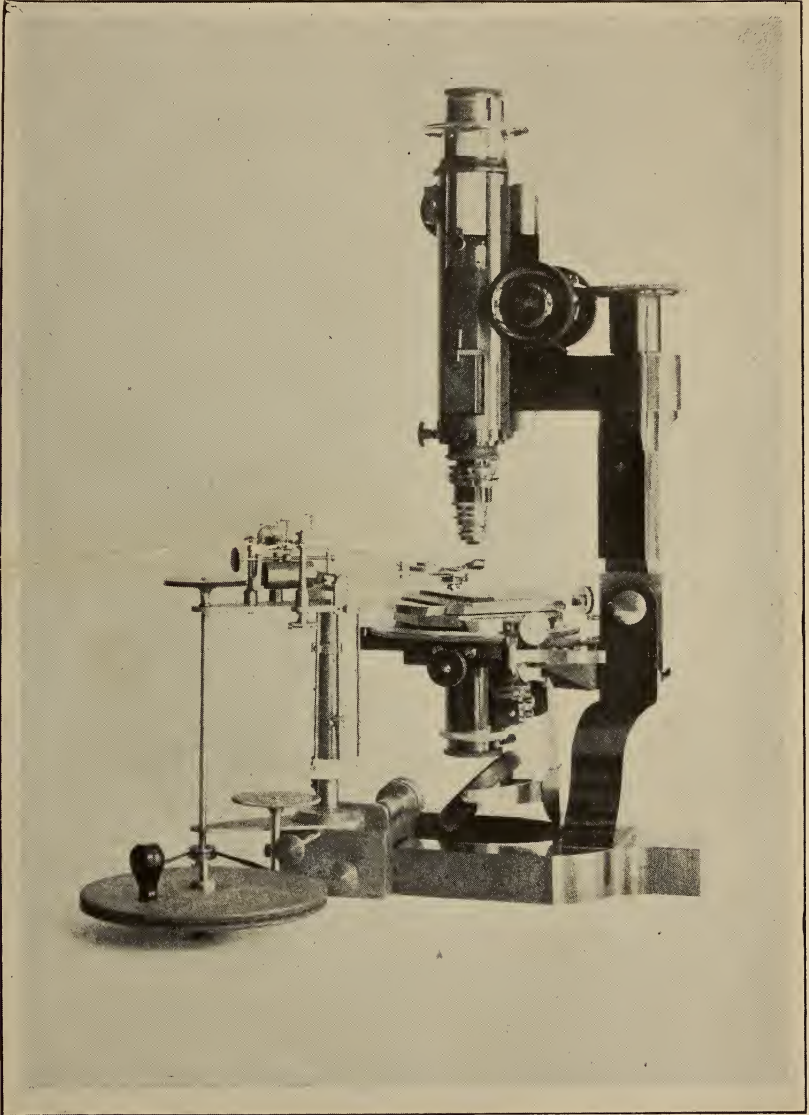

FIG. 1.—*Ostrea hatcheri* n. sp. One-third natural size.
FIG. 2.—*Ostrea philippii* n. sp. One-half natural size.
FIG. 3.—*Ostrea bourgeoisi* Rém. One-half natural size (copy).
FIG. 4.—*Ostrea patagonica* d'Orb. One-third natural size (copy).





THE MICROSCLEROMETER.



RARE QUARTZ TWINS!



Just arrived from Japan! 30 choice contact twins with twinning plane ξ (1122), similar to figure 11 on page 184 of Dana's System, but without the modifications, and with crystals quite flat (like figure 12), crystals about three-quarters of an inch in size. The excessive rarity of contact twins of quartz will make this little lot sell very rapidly at 50c. to \$2.00.

RARE ALEXANDER COUNTY, N. C., QUARTZ.

From our collector, who has already spent over two months in North Carolina, visiting all of the most desirable localities for us, we have received by far the finest lot we ever had of the famous Alexander County Quartz crystals. The crystals are mostly of the type shown in figure 17 on page 185 of Dana's System, though they often are much more complex, and at least five or six of them should be secured to show the different forms. Nearly all of them are perfectly clear and flawless, delicate, smoky crystals, with very brilliant faces; they range from three-quarter inch to 3 inches in length with diameter about one-third the length. Prices 10c. to \$2.00. A suite of five best quality crystals (averaging about 1 and $1\frac{1}{4}$ inches in length) postpaid for \$1.30.

WONDERFUL FINDS OF AMETHYST.

Our N. C. collector has been especially alert for fine Amethysts, and has visited numerous localities, has worked several and we have finally purchased outright the best locality we have ever heard of, and have already taken out **Thousands of Beautiful Specimens**, both single crystals and groups. We believe this is the most important find of Amethyst specimens ever made. The color is rich, the crystals well formed and of large sizes, every element is present which contributes to make a specimen desirable, including the fact that none have previously been in the market from this new locality in Iredell County, N. C. We also have a large lot of fine specimens from Macon County, N. C., and from Rabun County, Georgia, 10c. to \$5.00. Specimens at 50c. to \$2.50 will be acceptable additions to the very best collections.

OTHER NORTH CAROLINA MINERALS.

The loose terminated crystals of **Green Cyanite** secured by our collector continue to please scientific collectors. But few fine crystals, consequently, remain; 50c. to \$2.00.

A few good, large size **Columbite** crystals are still in stock at 50c. to \$2.50.

The **Iredell County Zircons**, of which a new lot has just arrived, increase in popularity as their merits become known—large size, rare form, bright faces, low prices: 5c. to 50c.

RARE CONNECTICUT MINERALS.

An exchange with a near-by University brings us some good and rare minerals; several loose crystals of **Monazite**, several small but good **Uraninite Crystals**, a little lot of **Columbite Crystals**, 22 terminated **Beryls**, several richly colored **Iolite** specimens, etc.

RARE COLORADO MINERALS.

An exceptionally interesting little shipment from a Colorado collector enables us to offer good, small specimens of **Crystallized Calaverite** and **Gold Pseudomorphs after Calaverite**; fine, large specimens of **Sylvanite**, also a few specimens of **Altaite** and the exceedingly rare **Melonite**; we are also able to furnish good specimens of **Johannite** and a lot of good and large, loose crystals of **Selenite** from a new Colorado locality.

Many other recent additions ought to be mentioned, but space forbids. Quite a number of them are noted in our Fall Bulletin recently published, mailed free on application.

124 pp. ILLUSTRATED CATALOGUE, 25c. in paper; 50c. in cloth.

44 pp. ILLUSTRATED PRICE-LISTS, 4c.; Bulletins and Circulars free.

GEO. L. ENGLISH & CO., Mineralogists,
64 East 12th St., New York City.

CONTENTS.

| | Page |
|---|------|
| ART. XLII.—A Microsclerometer, for determining the Hardness of Minerals; by T. A. JAGGAR, JR. (With Plate XII.) | 399 |
| XLIII.—Recent Observations on European Dinosaurs; by O. C. MARSH | 413 |
| XLIV.—Sapphires from Montana, with special reference to those from Yogo Gulch in Fergus County; by G. F. KUNZ | 417 |
| XLV.—Corundum-bearing Rock from Yogo Gulch, Montana; by L. V. PIRSSON | 421 |
| XLVI.—Crystallography of the Montana Sapphires; by J. H. PRATT | 424 |
| XLVII.—Electrical Measurement by Alternating Currents; by H. A. ROWLAND | 429 |
| XLVIII.—The alleged Jurassic of Texas. A Reply to Professor Jules Marcou; by R. T. HILL | 449 |

SCIENTIFIC INTELLIGENCE.

Chemistry and Physics—Thermal Phenomena attending Change in Rotatory Power, BROWN and PICKERING, 470.—Chemical Action of Electrical Oscillations, DE HEMPTINNE, 471.—Explosion of Chlorine Peroxide with Carbon Monoxide. DIXON, 472.—Absorption of Nitrogen by Carbon compounds under the influence of the silent Electric Discharge, BERTHELOT: Manual of Qualitative Analysis, C. R. FRESENIUS, 473.—Delay in spark discharges, E. WARBURG: Photoelectric relations of Fluorspar and of Selenium, G. C. SCHMIDT, 474.—Magnetic method of showing metallic iron: Spectra of certain stars, VOGEL and WILSING: Structure of the Cathode Light and the nature of the Lenard Rays. GOLDSTEIN: New Nicol Prism, 475.

Geology and Natural History—Observations on Baffinland, R. BELL, 476.—International Geological Congress, 477.—Mineral Resources of the United States, 1895, D. T. DAY: Descriptive Catalogue of Useful Fiber Plants of the World, including the structural and economic classifications of fibers, C. R. DODGE, 478.

Miscellaneous Scientific Intelligence—Natural Academy of Sciences, 479.—Cordoba Photographs, B. A. GOULD: November Meteors: Sixteenth Annual Report of the Bureau of American Ethnology. J. W. POWELL, 480.—Field Columbian Museum: American Journal of Physiology, 481.

INDEX, 482.



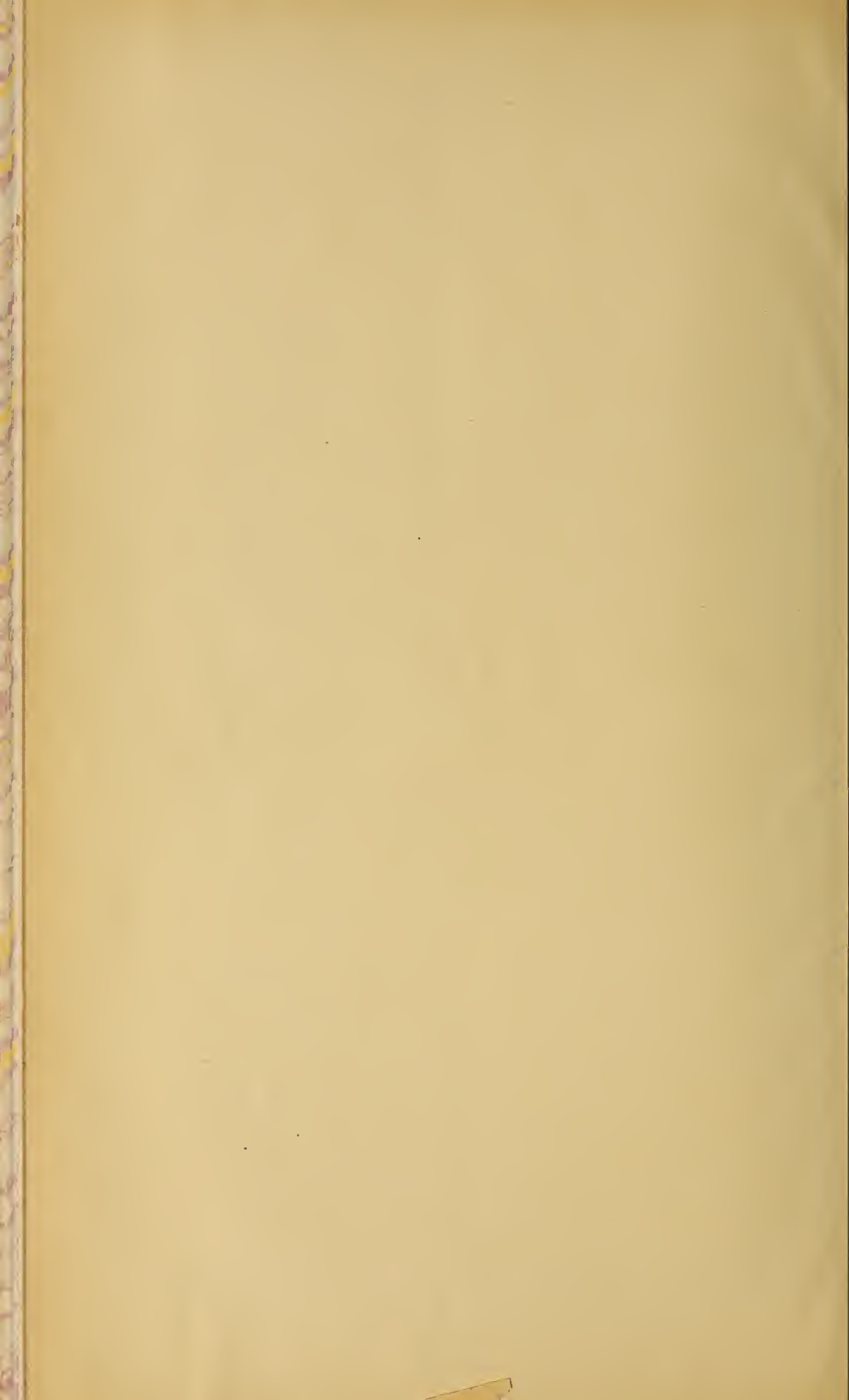







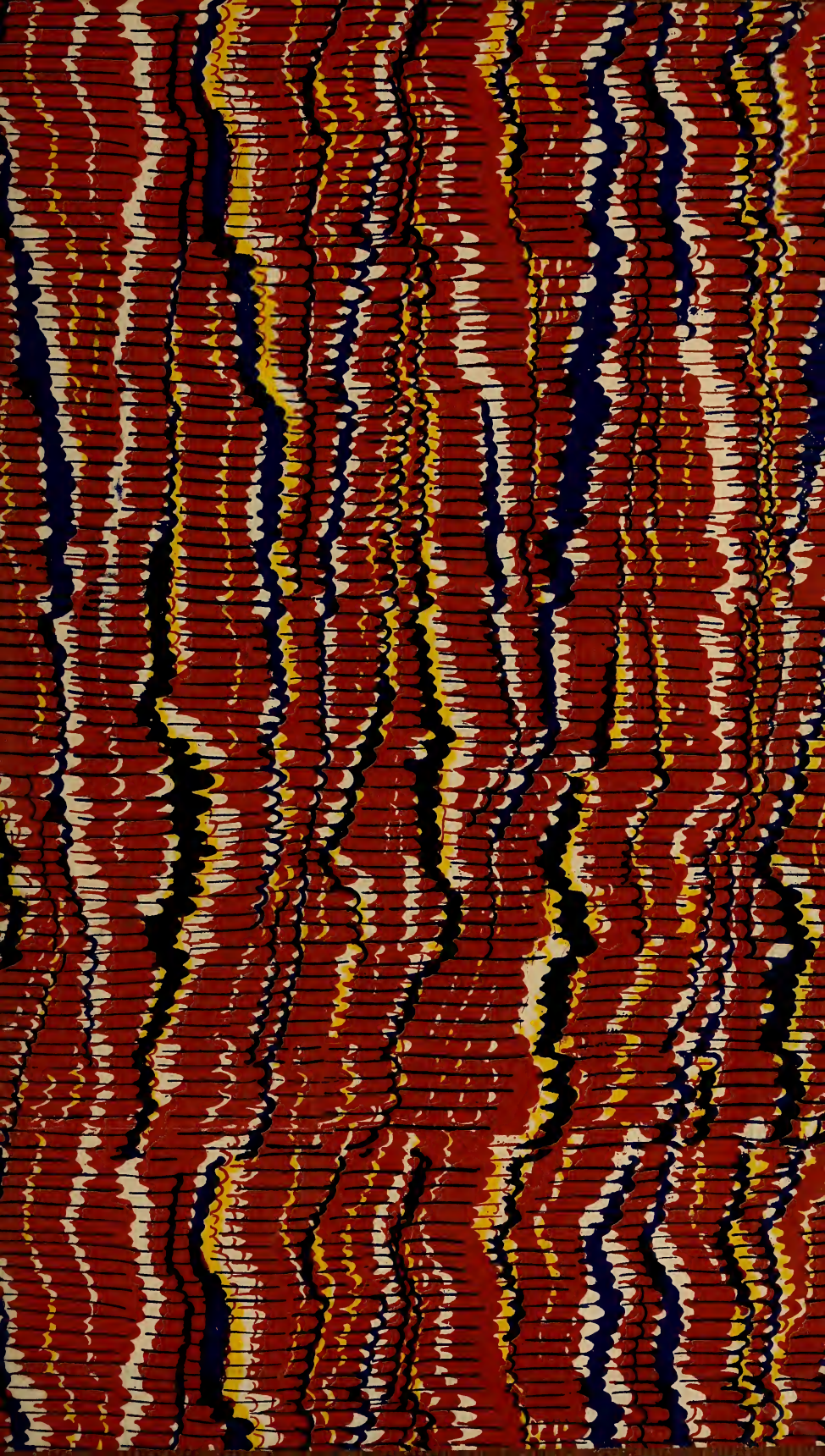

SMITHSONIAN INSTITUTION LIBRARIES



3 9088 01298 5552