



Calhoun: The NPS Institutional Archive
DSpace Repository

Theses and Dissertations

1. Thesis and Dissertation Collection, all items

2002-09

Implementing realistic helicopter physics in 3D game environments

Perkins, Keith M.

Monterey, California. Naval Postgraduate School

<http://hdl.handle.net/10945/4658>

Downloaded from NPS Archive: Calhoun



Calhoun is a project of the Dudley Knox Library at NPS, furthering the precepts and goals of open government and government transparency. All information contained herein has been approved for release by the NPS Public Affairs Officer.

Dudley Knox Library / Naval Postgraduate School
411 Dyer Road / 1 University Circle
Monterey, California USA 93943

<http://www.nps.edu/library>

NAVAL POSTGRADUATE SCHOOL Monterey, California



THESIS

**IMPLEMENTING REALISTIC HELICOPTER PHYSICS IN
3D GAME ENVIRONMENTS**

by

Keith M. Perkins

September 2002

Thesis Advisor:
Co-Advisor:

Michael Zyda
Michael Capps

This thesis done in cooperation with the MOVES Institute

Approved for public release; distribution is unlimited.

THIS PAGE INTENTIONALLY LEFT BLANK

REPORT DOCUMENTATION PAGE			Form Approved OMB No. 0704-0188	
Public reporting burden for this collection of information is estimated to average 1 hour per response, including the time for reviewing instruction, searching existing data sources, gathering and maintaining the data needed, and completing and reviewing the collection of information. Send comments regarding this burden estimate or any other aspect of this collection of information, including suggestions for reducing this burden, to Washington headquarters Services, Directorate for Information Operations and Reports, 1215 Jefferson Davis Highway, Suite 1204, Arlington, VA 22202-4302, and to the Office of Management and Budget, Paperwork Reduction Project (0704-0188) Washington DC 20503.				
1. AGENCY USE ONLY (Leave blank)		2. REPORT DATE September 2002	3. REPORT TYPE AND DATES COVERED Master's Thesis	
4. TITLE AND SUBTITLE: Title (Mix case letters) Implementing Realistic Helicopter Physics in 3D Game Environments			5. FUNDING NUMBERS	
6. AUTHOR(S) Perkins, Keith M.				
7. PERFORMING ORGANIZATION NAME(S) AND ADDRESS(ES) Naval Postgraduate School Monterey, CA 93943-5000			8. PERFORMING ORGANIZATION REPORT NUMBER	
9. SPONSORING /MONITORING AGENCY NAME(S) AND ADDRESS(ES) N/A			10. SPONSORING/MONITORING AGENCY REPORT NUMBER	
11. SUPPLEMENTARY NOTES The views expressed in this thesis are those of the author and do not reflect the official policy or position of the Department of Defense or the U.S. Government.				
12a. DISTRIBUTION / AVAILABILITY STATEMENT Approved for public release; distribution is unlimited.			12b. DISTRIBUTION CODE	
<p>13. ABSTRACT (maximum 200 words)</p> <p>The U.S. Army contracted the MOVES Institute at the Naval Postgraduate School to create a first person action game, America's Army, in support of Army strategic communication. The Army Game Project Team licensed Epic Game's Unreal game engine to produce this game. As the project progressed, the Army, realized that the game had the potential to cover a much larger scope than originally planned. Several of these "add-on" applications would call for the addition of realistic third person helicopter physics. Unfortunately this capability was not included in the award winning game engine nor the initial design of the game.</p> <p>These limitations are addressed by utilizing Unrealscript to design a physics system that interfaces with the Unreal Engine to smoothly interpolate between physics states within the bounds of helicopter capabilities, with the appearance of realism.</p> <p>The resultant helicopter physics system was incorporated into a game-like interface and compared to a similar system produced with a commercial graphics system. Overall, 53% of the test subjects thought the helicopter physics were <i>Very Realistic</i> or <i>Totally Realistic</i>, and 72% found them to be better than those of the system produced on the commercial graphics system. In a follow-up study, 86% of the participants found the helicopter physics to be equal to or better than the physics of a high quality commercial 3D helicopter game (57% better).</p>				
14. SUBJECT TERMS: Helicopter Physics, Army Game, 3D Virtual Environments, Game Engine, America's Army, 3D Interpolation, Simulation			15. NUMBER OF PAGES 101	
			16. PRICE CODE	
17. SECURITY CLASSIFICATION OF REPORT Unclassified	18. SECURITY CLASSIFICATION OF THIS PAGE Unclassified	19. SECURITY CLASSIFICATION OF ABSTRACT Unclassified	20. LIMITATION OF ABSTRACT UL	

THIS PAGE INTENTIONALLY LEFT BLANK

Approved for public release; distribution is unlimited

IMPLEMENTING REALISTIC HELICOPTER PHYSICS IN 3D GAME ENVIRONMENTS

Keith M. Perkins
Major United States Army
B.S., Hampton University, 1987
M.P.A., Troy State University, 1990

Submitted in partial fulfillment of the
requirements for the degree of

**MASTER OF SCIENCE IN
MODELING, VIRTUAL ENVIRONMENTS AND SIMULATIONS**

from the

**NAVAL POSTGRADUATE SCHOOL
September 2002**

Author: Keith M. Perkins

Approved by: Michael Zyda, Thesis Advisor

Michael Capps, Thesis Co-Advisor

Rudy Darken, Chair
Modeling, Virtual Environments and Simulation Academic Committee

THIS PAGE INTENTIONALLY LEFT BLANK

ABSTRACT

The U.S. Army contracted the MOVES Institute at the Naval Postgraduate School to create a first person action game, America's Army, in support of Army strategic communication. The Army Game Project Team licensed Epic Game's Unreal game engine to produce this game. As the project progressed, the Army, realized that the game had the potential to cover a much larger scope than originally planned. Several of these "add-on" applications would call for the addition of realistic third person helicopter physics. Unfortunately this capability was not included in the award winning game engine nor the initial design of the game.

These limitations are addressed by utilizing Unrealscript to design a physics system that interfaces with the Unreal Engine to smoothly interpolate between physics states within the bounds of helicopter capabilities, with the appearance of realism.

The resultant helicopter physics system was incorporated into a game-like interface and compared to a similar system produced with a commercial graphics system. Overall, 53% of the test subjects thought the helicopter physics were *Very Realistic* or *Totally Realistic*, and 72% found them to be better than those of the system produced on the commercial graphics system. In a follow-up study, 86% of the participants found the helicopter physics to be equal to or better than the physics of a high quality commercial 3D helicopter game (57% better).

THIS PAGE INTENTIONALLY LEFT BLANK

TABLE OF CONTENTS

I.	INTRODUCTION	1
A.	THESIS STATEMENT	1
B.	MOTIVATION	1
1.	The Need for Realistic Helicopter Physics.....	1
2.	What Makes This Helicopter Physics Model Different?	2
C.	FIDELITY	3
D.	SYSTEM CONSTRAINTS	3
E.	THESIS GOALS	4
F.	METHODOLOGY	4
G.	THESIS ORGANIZATION.....	4
II.	BACKGROUND	7
A.	INTRODUCTION	7
B.	AMERICA’S ARMY (THE ARMY GAME PROJECT)	7
1.	3D Games.....	8
C.	THE PARTS OF THE HELICOPTER	8
D.	THE BASICS OF HELICOPTER PHYSICS	10
1.	Lift.....	14
2.	Thrust.....	15
3.	Weight.....	16
4.	Drag.....	17
5.	Torque.....	17
E.	HELICOPTER CAPABILITIES	18
1.	RAH-66 Comanche.....	18
2.	UH-60L Black Hawk	20
F.	CONCLUSION	22
III.	SYSTEM DESIGN AND ARCHITECTURE	23
A.	INTRODUCTION	23
B.	REQUIREMENTS.....	23
C.	THE UNREAL SYSTEM.....	23
1.	General Description.....	23
2.	UnrealScript	24
3.	Unreal Virtual Environment.....	24
4.	Limitations.....	25
D.	CONCEPTUAL DESIGN	25
1.	Virtual Environment	26
2.	Instructions/Situation	27
3.	Apply Rules	27
4.	Act	28
E.	CONCLUSION	28
IV.	SYSTEM IMPLEMENTATION.....	31
A.	INTRODUCTION	31

B.	HELICOPTER PHYSICS IMPLEMENTATION	31
1.	<i>Class Helicopter</i>	31
2.	<i>Class HeloController</i>	31
C.	CONCLUSION	33
V.	EXPERIMENT AND RESULTS	35
A.	INTRODUCTION	35
B.	TESTING PHILOSOPHY	35
1.	Participant’s Helicopter Game Experience.....	35
2.	Participant’s Helicopter Experience	35
3.	Helicopter Flight Presentation.....	36
4.	Helicopter Flight Content	36
5.	Test flight.....	37
6.	Control Tool	38
7.	Control Game	39
8.	Survey	40
C.	PARTICIPANT POOL	41
1.	NPS Student Body.....	41
2.	NPS Faculty and Staff	42
D.	EXPERIMENT PROTOCOL	42
1.	Preparation.....	42
2.	Introduction.....	44
3.	Tool Experiment	44
a.	<i>Control Case.....</i>	45
b.	<i>Test Case 1.....</i>	45
c.	<i>Test Case 2.....</i>	45
d.	<i>Survey</i>	45
4.	Game Experiment.....	46
a.	<i>Control Case.....</i>	46
b.	<i>Test Case.....</i>	46
c.	<i>Survey</i>	47
E.	RESULTS	47
1.	Demographics.....	47
2.	Assessment of the Realism of the Helicopter Physics: Experiment 1	48
3.	General Results: Experiment 1.....	49
4.	Assessment of the Realism of the Helicopter Physics: Experiment 2	53
5.	General Results: Experiment 2.....	53
F.	CONCLUSIONS	55
VI.	CONCLUSIONS AND FUTURE WORK.....	57
A.	INTRODUCTION	57
B.	FUTURE WORK.....	57
1.	Further Testing	57
2.	Optimization.....	57
3.	Implementing More Modules	58

4.	Increase Fidelity	58
5.	More Helicopter Models.....	58
C.	CONCLUSION	59
APPENDIX A	61
A.	INTRODUCTION	61
APPENDIX B	63
A.	INTRODUCTION	63
LIST OF REFERENCES	79
INITIAL DISTRIBUTION LIST	81

THIS PAGE INTENTIONALLY LEFT BLANK

LIST OF FIGURES

Figure 1.	Graphics from goarmy.com website	7
Figure 2.	Most common helicopter parts.....	9
Figure 3.	Illustrating the requirement for a tail rotor	10
Figure 4.	Helicopter directional traveling abilities.....	11
Figure 5.	Airfoil illustration	12
Figure 6.	Bernoulli's principle	13
Figure 7.	Balance of Forces acting on a helicopter	14
Figure 8.	Tilting the main rotor increases thrust but reduces lift	16
Figure 9.	Weight formula	16
Figure 10.	Helicopter torque	18
Figure 11.	Comanche in desert.....	19
Figure 12.	Black Hawk dimensions	21
Figure 13.	UH-60 Black Hawk	22
Figure 14.	Four Module Physics System Design	26
Figure 15.	Screen shot of Lo_Res Version of AGP Helicopter Physics	38
Figure 16.	Screen shot of Hi_Res Version of AGP Helicopter Physics	38
Figure 17.	Screen shot of Vega Version Helicopter Physics	39
Figure 18.	Screen shot of Enemy Engaged Commercial 3D Helicopter Game	40
Figure 19.	Screen shot of No_Physics Version of AGP Helicopter Physics	45

THIS PAGE INTENTIONALLY LEFT BLANK

LIST OF TABLES

Table 1.	RAH-66 Comanche specifications and diagram.....	19
Table 2.	Black Hawk’s weights and performance	20
Table 3.	Black Hawk’s specifications.....	21
Table 4.	Black Hawk cabin dimensions/capacity	22
Table 5.	Initial Design Goals	29
Table 6.	Survey Grading Criterion.....	49
Table 7.	Distribution of Participants by Age-Experiment 1	50
Table 8.	Distribution of Participants by Gender-Experiment 1	50
Table 9.	Distribution of Participants by Game Experience-Experiment 1	50
Table 10.	Distribution of Participants by Experience-Experiment 1	51
Table 11.	Participants ratings of Army Game Hi_Res Physics-Experiment 1	51
Table 12.	Army Game Hi_Res Realism Ratings Relative to Vega Realism Ratings	52
Table 13.	Distribution of Participants by Age-Experiment 2	53
Table 14.	Distribution of Participants by Gender-Experiment 2	53
Table 15.	Distribution of Participants by Game Experience-Experiment 2	54
Table 16.	Distribution of Participants by Experience-Experiment 2	54
Table 17.	Participants ratings of Army Game Hi_Res Physics-Experiment 2	54
Table 18.	Army Game Realism Ratings Relative to Enemy Engaged Ratings	55
Table 19.	Realism Survey Results Experiment 1, (1 of 4).....	73
Table 20.	Realism Survey Results Experiment 1, (2 of 4).....	74
Table 21.	Realism Survey Results Experiment 1, (3 of 4).....	75
Table 22.	Realism Survey Results Experiment 1, (4 of 4).....	76
Table 23.	Realism Survey Results Experiment 2.....	77

THIS PAGE INTENTIONALLY LEFT BLANK

LIST OF ACRONYMS

2D	Two-dimensional
3D	Three-dimensional
AI	Artificial Intelligence
AGP	Army Game Project
BET	Blade Element Theory
BOF	Balance Of Forces
CMS	Combat Mission Simulator
FM	Field Manual
GHz	Giga Hertz
Helo	Helicopter
Hi_Res	High Resolution
JTF	Joint Task Force
LCT	Longbow Crew Trainer
Lo_Res	Low Resolution
MB	Mega Byte
Medevac	Medical Evacuation
MOVES	Modeling, Virtual Environments, and Simulation
NOTAR	No Tail Rotor
NPS	Naval Postgraduate School
PC	Personal Computer
RAM	Random Access Memory
VE	Virtual Environment

THIS PAGE INTENTIONALLY LEFT BLANK

ACKNOWLEDGMENTS

This thesis is dedicated to my children, Keith II, Christen, Loria, Iliana, and Aaron. I hope this achievement shows you that if an old guy like your father can accomplish this, you can do much bigger and better things. Set your eyes on a star and go for it!

I would like to thank several people who have especially made it possible for me to complete this work:

- Dr. Michael Capps for your guidance and support from beginning to end. Thanks for staying involved all the way from across country.
- Dr. Michael Zyda for your guidance as Director of the MOVES Institute and your efforts as my thesis advisor. Thanks for stepping in at the end and making my research efforts a success.
- Ms. Rosemary Minns for your assistance in the admin areas...sometimes the most important areas. And for your assistance in framing my thesis title.
- Professor John Hiles for your special session on software design. Thanks for your continued interest in my success.
- Dr. Rudy Darken, Chair MOVES Academic Committee, for your support throughout my degree program. Your training in VE class will be put to immediate use in my next assignment.
- AGP Programmers, Christian, Steve, Martin, Kevin and Level Developer Scott for your assistance understanding the ins and outs of programming with the massive Unreal Engine and the temperamental Unreal Editor.
- Cordelia D. Perkins and Norman A. Perkins Jr. Thanks Mom and Pop for always supporting me.
- All the students and staff who volunteered to participate in my experiments.

Finally, I would like to say a very special thank you to my wife, Nancy. Your understanding, patience, and love were key in enabling me to successfully complete this endeavor.

THIS PAGE INTENTIONALLY LEFT BLANK

I. INTRODUCTION

A. THESIS STATEMENT

It is possible to design a rule-based system that smoothly interpolates between physics states within the bounds of helicopter capability, with the appearance of realism.

B. MOTIVATION

There is a growing gap between military simulation development and commercial entertainment software development. Military simulations are typically more expensive, require specialized hardware to run on, and realism is a critical component. In contrast, 3D Games typically don't require specialized hardware, are relatively inexpensive, and focus on entertainment value more than realism. Although discussion of the pros and cons between these two industries is beyond the scope of this thesis, it is pertinent to point out that thus far, military simulations have focused almost exclusively on 1st person helicopter simulations whereas, 3D games have expanded their focus on both 1st person and 3rd person helicopter products. Unfortunately, what this means, is that most of the 3rd person helicopter physics has been designed with entertainment value as the driving force in lieu of realism.

1. The Need for Realistic Helicopter Physics

Because the Army game may be used in military training, it is more critical that the helicopter physics be realistic. The current trend in military missions is joint interoperability. The Army does not fight alone and neither do the other services. Most of the traditional deployment paradigms have been broken. Units no longer deploy together. Units may train with other units of the same command, but when it comes time to assemble the Joint Task Force (JTF) bits and pieces from many different units are combined to accomplish the mission. Considering the fact that the JTF is usually comprised of units from various commands, services, countries, and continents, the need for training before and during deployment is challenging and critical. Training systems, especially simulation systems, must be as realistic as possible within platform constraints. There is a growing need for simulations to expand to consider many types of deployments, not just traditional type of deployments. Military simulation training

developers no longer have the luxury of assuming that realism in certain parts of their simulation is optional. Simulations/trainers in the Army are almost never only used for their intended purpose. The Army changes and adapts (improvises) and this ability/flexibility should also be provided in Army training systems.

It is important that military training be realistic for several reasons. The most important reason is that most military operations (live or training), have a high risk factor. If things go wrong, life or limb could be at stake. The lack of realism in a training tool may result in a negative training effect. For example, if a soldier is trained with a system that improperly depicts the look or silhouette of friendly helicopters, that soldier may have problems distinguishing between friendly and enemy helicopters during a conflict. This is negative training, because by using the system the soldier has wrongly learned that friendly helicopters can look different than they actually can. Another reason for realism in military trainers is for immersion. Many military trainers rely on immersion to aid the training process. If a soldier is using the system for something like a mission rehearsal, and is heavily immersed, but then sees a totally unrealistic helicopter fly by, a portion if not all of the sense of presence, is lost, and the training value may be reduced.

Accordingly, the Army game is designed to be an infantry squad level action game. The initial areas that require realistic helicopter physics are for initial soldier placement, soldier movement, air assault operations and medevac operations (soldier killed). Additionally, there is a possibility that there will be a helicopter game add-on to the Army game in the near future, which would demand good helicopter physics.

Finally, it is hoped the system could be ported over to other application (military or entertainment) and languages i.e. NPSNET V, X3D Capture the Flag, Java, C++, etc.

2. What Makes This Helicopter Physics Model Different?

The helicopter is arguably one of the most complex flying machines invented by man [Sadler 95]. The helicopter's complexity is evident by the various unique maneuvers it is capable of: hover, rotate, and fly backwards. The military has a small number of high fidelity helicopter simulators i.e. Combat Mission Simulator (CMS) and Longbow Crew Trainer (LCT). But, they have virtually no high fidelity third person models in their simulators. Although the 3D Gaming industry has numerous third person

helicopter models, they are rarely realistic and not intended for training. This research attempts to model the helicopters unique capabilities, while leveraging the best of military simulation development and commercial game development. It is hoped that this will be accomplished by providing a system focused on realism that does not require specialized equipment. One must seriously consider the afore mentioned gap between these two school of thought, and the inherent difficulties of helicopter modeling, before attempting to take on this unique challenge.

C. FIDELITY

There are many definitions for fidelity. In fact, the term fidelity is used extensively in describing virtual environments and simulations in military applications. As stated previously, realism/fidelity is crucial to the successful employment of simulations and virtual trainers in military applications. For the purposes of this research, fidelity refers to how realistic the helicopter flight appears. It is paramount to note that although realism is subjective, it is hoped that the research will be able to document the level of realism for the system produced. This study is focused on providing a good level fidelity for a person who: has seen a helicopter flight, either in person or on video; has possibly ridden in a helicopter; but, is not a helicopter pilot. It is believed that a helicopter pilot has too much experience and information to be the target audience for this research. Even though the Army Game will be widely distributed, it is believed only a minute number of people who play the game will actually be a helicopter pilot. With this in mind, it would not be practical to put the realism required to satisfy a helicopter pilot into the system at this time.

D. SYSTEM CONSTRAINTS

The system is designed to be used in the Army Game. The Army Game has been developed for use on a typical PC. This fact is an immediate constraint on the level of fidelity that can be achieved. Using algorithms for realistic physics like the Blade Element Theory (BET) used in high-end flight simulators, is not an option without specialized hardware.

Additionally, the Army Game is built on the Unreal Engine. Thus, it is necessary to use existing game development tools that are usually not optimized for realism. In fact, many game development tools are focused on generating high frame rates, detailed graphics, and fun. These existing tools at times can be useful, but usually come with a cost, in the form of additional constraints.

E. THESIS GOALS

The overall goals for this thesis are:

- Develop a physics system that provides realistic helicopter behavior and smooth interpolation between physics states for the Army Game Project.
- Provide generic architecture to facilitate future investigations atop other applications

F. METHODOLOGY

The research began with a review of relevant literature, 3D games, and military simulations to determine if any existing methods could be leveraged for use in the proposed system. Concurrently, reviews of video clips and live helicopter flights, provides a benchmark for the highest level of helicopter flight fidelity. Next, study of the UnrealScript programming language and the Unreal Engine provides insight into the capabilities and constraints of the target system. Afterwards, a task analysis, detailing each stage of transition (physics state) for the helicopter is conceptualized, produced, analyzed and placed into a rough flowchart. This flowchart is then molded into the conceptual framework/modules for the flow of data and controls for the helicopter. After these modules are encoded, they are tested and tuned for the purposes of the research. Next, the system will is tested against a system designed in a commercial graphics package to demonstrate the level of realism achieved and illuminate areas for future implementation and study.

G. THESIS ORGANIZATION

This thesis is organized into the following chapters:

- **Chapter II:** Background. Provides an overview of the Army Game Project. Describes some basics of helicopter physics. Describes some basics of U.S. Army helicopter capabilities and operational constraints.
- **Chapter III:** System Design and Architecture. Describes helicopter physics states and motion equations.
- **Chapter IV:** System Implementation. Describe the process, methodology, and major algorithms/code created during the development of the helicopter physics system
- **Chapter V:** System Analysis and Results. Shows and analyzes the resulting summary statistics for the experiment testing the system.
- **Chapter VI:** Conclusions and Future Work. Indicates conclusions of this research effort. Discusses the system's potential for more advanced applications.

THIS PAGE INTENTIONALLY LEFT BLANK

II. BACKGROUND

A. INTRODUCTION

There are many facets of helicopter physics. Depending on what approach is considered, different factors must be considered to successfully model helicopter flight. One must consider the platform that the helicopter physics will be modeled on. Will it run on a PC or a super computer? One must consider the various parts of a helicopter along with the various forces that act on these parts. Finally, one must consider the helicopter capabilities. How fast can it climb/fly? The remainder of this chapter will review these various tenants in detail as they pertain to this research.

B. AMERICA'S ARMY (THE ARMY GAME PROJECT)

America's Army is a first person action game developed by the MOVES Institute of the Naval Postgraduate School. The introduction statement on the Army's official website reads "The U.S. Army has developed a highly realistic and innovative PC video game that puts you inside an Army unit. You'll face your first tour of duty along with your fellow Soldiers. Gain experience as a Soldier in the U.S. Army, without ever leaving your desk." [<http://www.goarmy.com>, 2002]



Figure 1. Graphics from goarmy.com website. From Ref. [<http://www.goarmy.com/index07.htm#>].

America's Army is a first person action game that allows the player to virtually experience being a soldier in the U.S. Army. Players join a game via a server on the Internet and participate with other team members to accomplish a prescribed mission. Players can also go through various training modules to build their individual skills before embarking on a group mission. There has been a large amount of interest in the Army about modifying the game and utilizing it for various training needs. One of the things missing from the game is vehicle type applications. The game focuses on infantry skills. However, an important part to the infantry/ground troop mission is helicopter operations. From the simple application of transport and medevac, to the more complex functions of supporting fires, reconnaissance, and special operations extraction, helicopters are critical to the overall infantry mission.

1. 3D Games

As stated previously, the Army licensed the Unreal game engine from Epic Games. Although this, award winning, engine is extremely capable, it also is lacking in the area of helicopter physics. Many other video games include helicopters but omit realistic third person helicopter behaviors in their applications. Of the 48 helicopter simulation/games I found, only about a third actually implement some sort of third person helicopter physics. Some of these games are listed below:

- *Apache/Havoc* by Razorworks, 1998
- *Comanche 4* by NovaLogic/Electronic Arts, 2001
- *Enemy Engaged: RAH-66 Comanche vs. KA-52 Hokum* by Razorworks/Empire Interactive Entertainment, 2000
- *Search & Rescue 2* by InterActive Vision Games/Globalstar Software, 2001
- *Army Men: Air Attack* by 3DO/Sony Computer Entertainment America, 2001

C. THE PARTS OF THE HELICOPTER

The parts on a helicopter vary, depending on the model, manufacturer, and purpose. The following (see Figure 16.), illustrate a few of the most common parts that are found on most helicopters.



Figure 2. Most common helicopter parts. From Ref. [Sikorsky, 2000].

The main rotor is the propeller that is usually found on top of the cockpit. These rotating wings or airfoils control the amount of lift applied by the helicopter. The main rotor determines whether the helicopter goes forward, backwards, left, right, or up or down. These directions are controlled by the speed the airfoils are spinning and their angle of attack on the drive shaft.

The tail rotor is the small propeller found at the end of the tail boom. As shown in Figure 17, the primary purpose of the tail rotor is to prevent the helicopter from spinning in the opposite direction of the main rotor. According to Newton's third law, a helicopter without a tail rotor would begin to spin in the opposite direction as the main rotor until the body of the helicopter would be spinning at the same speed as the propeller. Another purpose of the tail rotor is to pivot the helicopter around the drive shaft's axis. Through manipulation of the angle of attack of the tail rotor, the pilot is able to pivot while performing a variety of maneuvers.



Figure 3. Illustrating the requirement for a tail rotor. From Ref. [http://www.phy.cuhk.edu.hk/phyworld/iq/helicopter/helicopter_e.html].

D. THE BASICS OF HELICOPTER PHYSICS

A helicopter has three unique abilities not found in most vehicles: hover, fly backwards, and rotate. A helicopter can just stop in mid-air and just hang in the sky (hover). A helicopter can move laterally in any direction. A helicopter does not have to be moving in order to turn. It can turn from a hover and rotate in a complete circle (360 degrees). A helicopter can travel backwards as well as forward, straight up or straight down. The helicopter pilot controls the lateral movement of the helicopter (forward, backwards, left, right) with the cyclic (sometimes called the Stick). The down and up motion and engine speed is controlled by the collective (not to be confused with the Borg), another stick. The tail rotor is controlled by two foot-pedals. The rotor controls the rotation of the helicopter about its axis. The rotor also prevents the fuselage from spinning counter to the propellers in accordance with Newton's 3rd Law; for every action, there is an equal and opposite reaction.

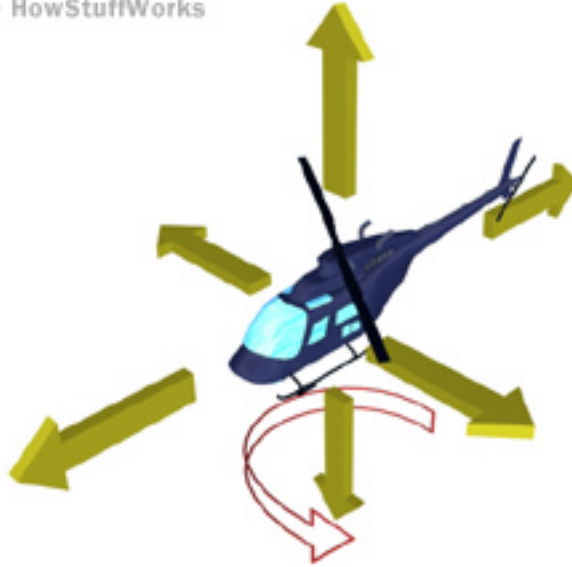

Figure 4. Helicopter directional traveling abilities. From Ref. [Brain, 2000].

Two different methods of defining helicopter aerodynamics were considered, “blade element theory” and “balance of forces”. Blade element theory is very complex and computationally intensive. It is used in high dollar flight simulations. Basically, blade element theory defines the physics of flight by considering the consequences of each individual force, acting upon each individual airfoil/rotor blade. This method of simulation coupled with specialized computer hardware can provide real time calculations giving pilots fast performance and complex integration and a level of realism second only to actual flight [Lentz, 1995]. For the purposes of this research, blade element theory was considered to be too computationally expensive for a PC based video game. Generally, some basic parts of blade element theory are present in any attempt to model rotary craft flight.

To truly understand why a helicopter flies, one must understand what an airfoil is and what part it plays in allowing flight. Basically, an airfoil (see Figure 5) is any device designed to produce thrust or lift, when passed through air. Examples of airfoils include helicopter rotors, airplane propellers and wings.

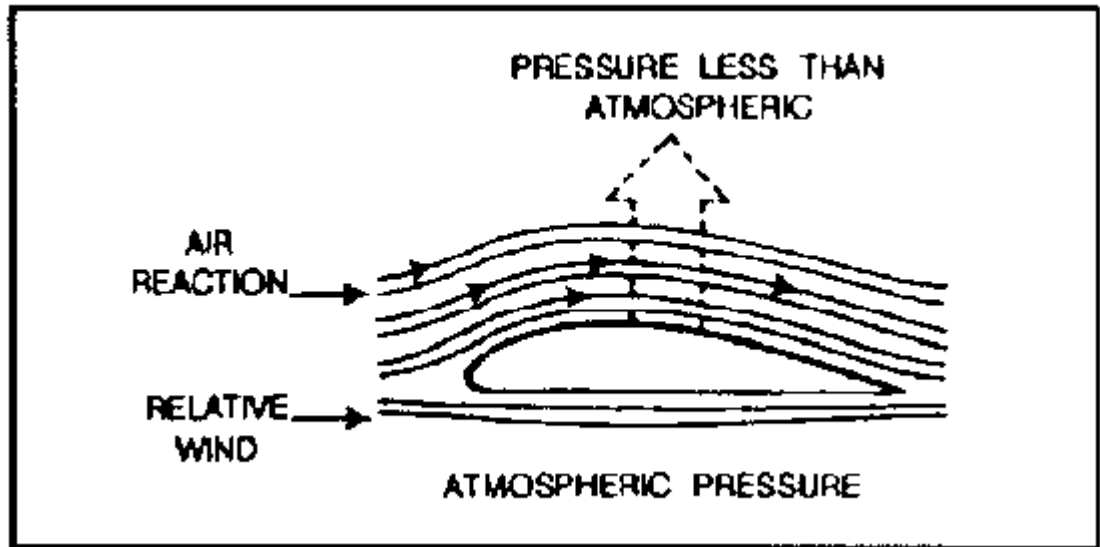

Figure 5. Airfoil illustration. From Ref. [FM 1-514, 1991].

The Bernoulli principle reports that as air moves across a surface, the air pressure on that surface decreases. Bernoulli, an eighteenth century physicist, found that as the air speed across a surface increases, the surface air pressure on that surface decreases. As the airfoil moves it divides the mass of air molecules. Since the airfoil is curved at the top, the molecules that flow over the top have to move at a faster rate, in order to arrive at the end of the airfoil at the same time as the molecules that flow under the airfoil. Hence, applying the Bernoulli principle (see Figure 6), the faster molecules on top of the foil cause a low-pressure area above the foil. Since the air pressure below the airfoil is now greater than the pressure above, the high pressure pushes the foil up into the lower pressure area. This phenomenon is called lift. Lift is addressed in more detail in the following section.

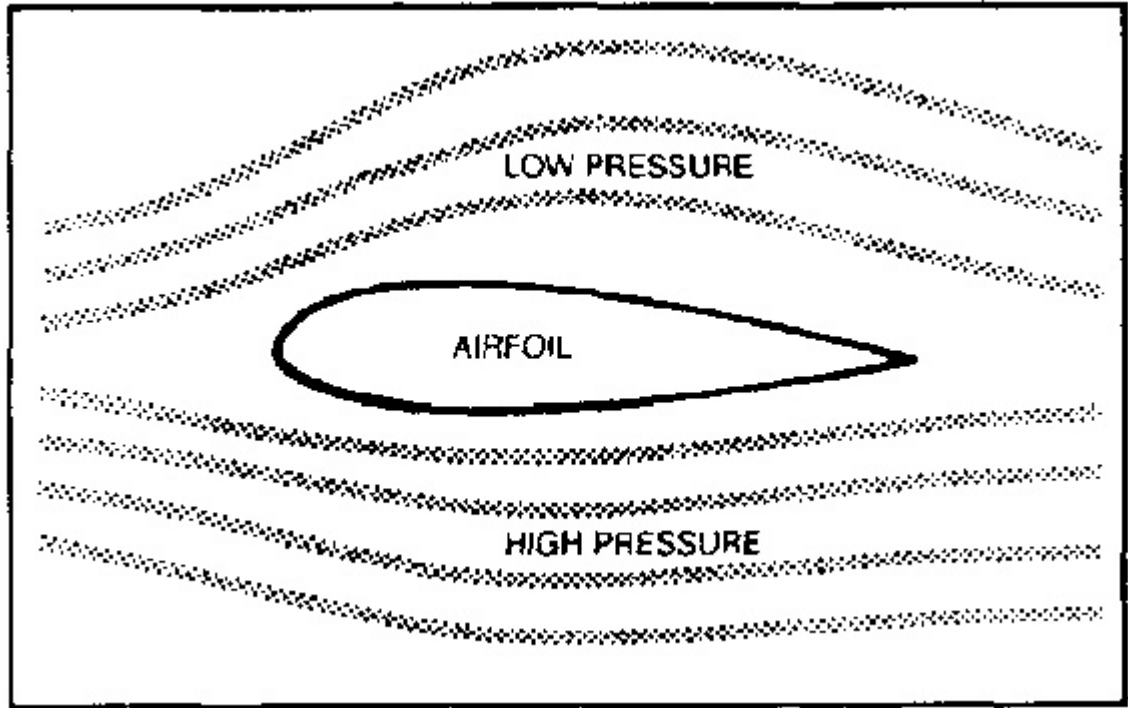

Figure 6. Bernoulli's principle. From Ref. [FM 1-514, 1991]

The method chosen for this research is the "balance of forces" method. This method defines the physics of flight by considering the consequences of the major forces action on the helicopter fuselage/body. The main forces (see Figure 7) acting on the helicopter are lift, thrust, weight, drag, and torque.

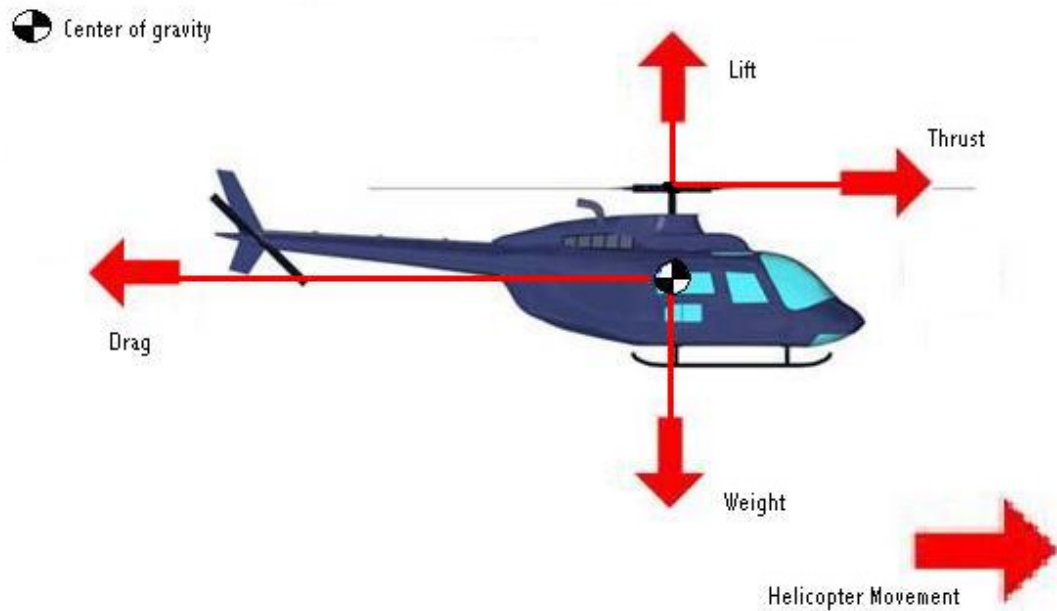

Figure 7. Balance of Forces acting on a helicopter.

1. Lift

As stated earlier, lift is produced by air flowing over an airfoil. That airfoil can either be the wing of an airplane or the main rotor blades of a helicopter. Lift is technically produced by a combination of forces resulting from Newton’s third law of motion and Bernoulli’s principle. Newton’s third law states that “for every acting force, there is an equal and opposite reacting force.” As air molecules strike the airfoil and are forced down as the acting force, the airfoil is forced up as an effect of the reacting force. Lift is the force that counteracts the weight of the aircraft and allows it to rise into the air. If lift exceeds weight, the helicopter rises. If lift equals weight, the helicopter hovers. Lift emanates from the main rotor. Lift is directly dependent upon the characteristics of the airfoil employed.

There five major factors about an airfoil that determine the amount of lift that can be produced:

- Shape
- Size
- Speed
- Angle of attack/pitch angle
- Air Density

The shape and size of an airfoil help determine the amount of lift that can be produced. In theory, if two airfoils are identical in every manner except size, the larger airfoil would be capable of providing greater lift than the smaller one. Recalling Bernoulli's principle above, it is the convex shape of the top of an airfoil that causes some air molecules to travel farther and thus faster. Additionally, a smooth surface airfoil has more lift than the same foil with a rough surface, because of the increase in drag with the rough surface. Likewise, as the speed of the air molecules traveling across the airfoil increase, so does the amount of lift.

The angle of attack is the angle that the air molecules strike the airfoil. The relative wind is the direction of the airflow as compared to the airfoil [FM 1-514, 1991]. The angle between the airfoil and the relative wind is called the angle of attack. The amount of lift produced is directly linked to the angle of attack. For example, if a helicopter's angle of attack gets too great, the airflow across the foil is broken and falls off towards the end of the foil and the helicopter stalls. The point where this phenomenon occurs is called the "critical angle of attack."

2. Thrust

Thrust for a helicopter is a little different than thrust for an airplane. In an airplane, the engine provides the thrust, which moves the plane forward, and the wings provide the lift. With a helicopter, the main rotor blades provide both lift and thrust. While a plane basically provides forward thrust, a helicopter can produce thrust in any direction by simply tilting the main rotor in that direction. This is what allows the helicopter to fly sideways, backwards, and hover. Thrust emanates from the center of the main rotor. As can be seen in Figure 8, by tilting the main rotor forward, the helicopter has increased its thrust. Although the total lift/resultant is the same as it would be had the blades not been tilted (assuming all other factors remained the same), the vertical lift or effective lift is actually reduced. Thus the helicopter will propel forward but begin to lose altitude. A pilot would have to apply more engine power to maintain the current altitude.

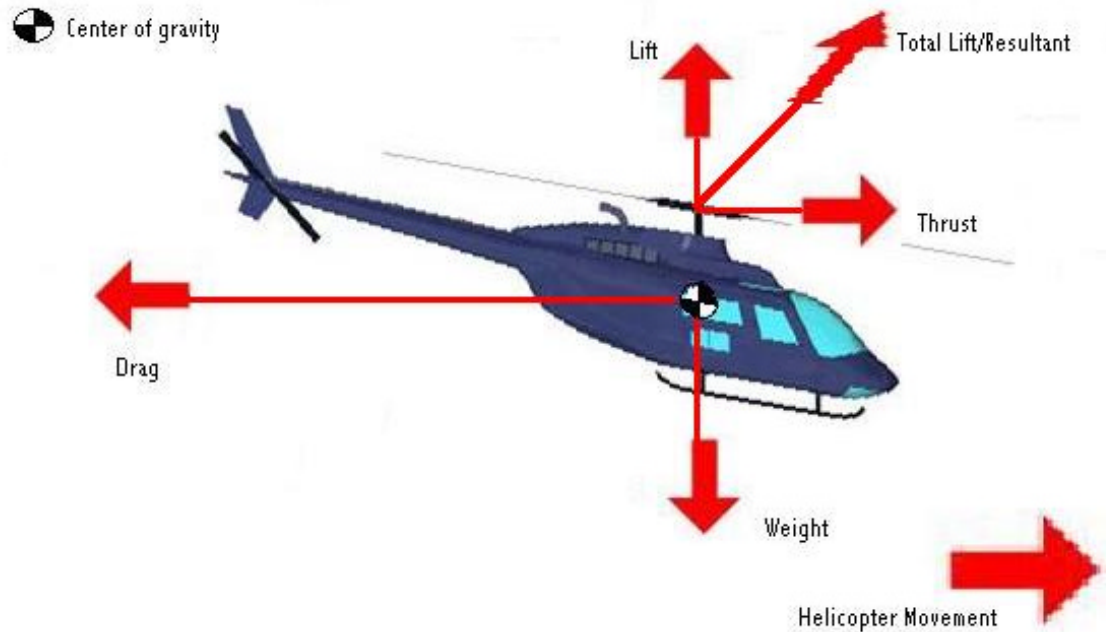

Figure 8. Tilting the main rotor increases thrust but reduces lift

3. Weight

Weight is the force of gravity on the helicopter's center of gravity. The center of gravity is the point on the helicopter where it would balance if suspended from a wire or rope. Weight (see Figure 8) pulls on the helicopter towards the ground. If weight is greater than lift, the helicopter descends. Weight can be derived from the following formula:

$$F = m * a$$

F = Force, the weight force acting on the helicopter
m = mass, the mass of the helicopter
a = acceleration, Force of gravity

Figure 9. Weight formula.

As a helicopter flies, the force of weight is constantly changing due to the fact that the mass component of the formula is changing as fuel is consumed. Therefore, as a

helicopter attempts to maintain a certain altitude and attitude, it will require less and less power the longer it flies [Lentz, 1995].

4. Drag

Drag (see Figure 20.) is the force that works counter to thrust. Drag originates at the center of gravity of the helicopter. As the velocity of the helicopter increases, drag increases. The amount of drag present is also dependent upon the orientation of the helicopter's fuselage in respect to the oncoming airflow. Applying the appropriate amounts of thrust will counteract drag and allow a helicopter to remain in motion or accelerate. There are two kinds of drag in helicopter flight, parasitic and induced. Parasitic drag is produced as the air resists the helicopter as it flies. Induced drag is produced as a result of the low-pressure areas that are formed in the wake of the helicopter as it flies. Remembering Bernoulli's principle, one can see how this would cause the air to push in a direction opposite of which the helicopter is flying.

5. Torque

As mentioned earlier, one of the main purposes of the tail rotor is to prevent the helicopter fuselage from turning in a clockwise direction (see Figure 22.) as a result of the main rotor turning in a counter-clockwise direction. Once again, Newton's third law has a profound effect on helicopter flight. Although, during the early days of helicopter development, this torque force was a major point of failure, it has become a key function in the modern helicopter. The tail rotor torque action is used to control the direction in which the helicopter faces.

Torque in helicopters is usually counteracted in one of three ways:

- A tail rotor- to provide counter-torque
- Two main rotors- spinning in opposite directions
- NOTAR – jet engine used like a tail rotor

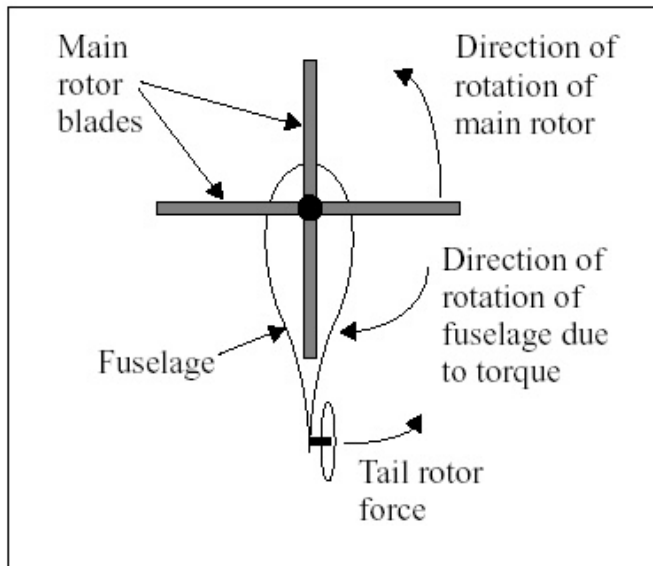

Figure 10. Helicopter torque. From Ref. [Lentz, 1995].

E. HELICOPTER CAPABILITIES

Currently, there are two helicopters used in this research. The first helicopter, RAH-66 Comanche is modeled for the control flight (Vega version). The second helicopter, UH-60L Black Hawk is modeled for the test flight (Army Game version). It is hoped that more models be added in the future. The following sections give a brief description of these two helicopter and lists some of their capabilities.

1. RAH-66 Comanche

The Comanche is the U.S. Army's next generation attack helicopter. It is scheduled for mass production and fielding in 2004. The Boeing Company in conjunction with Sikorsky Aircraft is manufacturing the Comanche aircraft. Due to the newness of this rotorcraft, many of the specific capabilities for this craft are either unavailable or undetermined. The following information is provided to provide some idea of what the Comanche is capable of:

<p>Powerplant:</p> <ul style="list-style-type: none"> • Two T800-LHTEC-801 turboshaft engines 	
<p>Rotor system:</p> <ul style="list-style-type: none"> • Five-bladed, bearingless main rotor • FANTAIL anti-torque 	
<p>Facts:</p> <ul style="list-style-type: none"> • Self-healing digital mission electronics • Longbow fire-control radar • Passive long-range, high-resolution sensors • Triple-redundant fly-by-wire flight control system • Wide-field-of-view helmet-mounted display • Simple remove-and-replace maintenance system 	
<p>Milestones:</p> <ul style="list-style-type: none"> • April 1991: Dem/val prototype (contract go-ahead) • January 1992: Preliminary design review • November 2004: Initial production 	
<p>Crew:</p> <ul style="list-style-type: none"> • Low-work crew station - 2 	

Table 1. RAH-66 Comanche specifications and diagram. From Ref. [http://www.boeing.com/rotarycraft/military/RAH66/flash.html]



Figure 11. Comanche in desert. From Ref. [http://www.boeing.com/rotarycraft/military/RAH66/flash.html].

2. UH-60L Black Hawk

The Black Hawk is the U.S. Army's replacement for the UH-1 Huey series utility helicopters. Unlike the joint venture of Boeing and Sikorsky on the RAH-66 Comanche, this time these two rotorcraft developers were competing for the Army contract. Ultimately the Sikorsky design of the YUH-60 was selected over Boeings YUH-61 and its first flight was 17 October 1974. Although the U.S. Army planned to obtain over 2,200 Black Hawks, approximately 1,725 Black Hawks have been built for the Army. However, Both the Air Force and Navy have also obtained variants of the Black Hawk [aerospacweb.org, 2000]. The MH-60 is the Special Operations version. The following tables and figures show the Black Hawk's unique capabilities:

WEIGHTS		
■ Maximum takeoff gross weight	22,000 lb	9,977 kg
■ Empty weight, standard configuration	11,744 lb	5,326 kg
■ Maximum gross weight, external load	23,500 lb	10,658 kg
■ Maximum external load	9,000 lb	4,082 kg

POWERPLANT		
<i>ratings per engine, standard day, sea level</i>		
■ Type	Two General Electric T700-GE-701C	
■ 2.5-minute OEI contingency	1,940 shp	1,447 kw
■ 10-minute takeoff power	1,890 shp	1,409 kw
■ 30-minute intermediate power	1,800 shp	1,342 kw
■ Maximum continuous power	1,662 shp	1,239 kw
■ Normal fuel capacity, usable	359.7 gal	1,362 l

PERFORMANCE		
<i>22,000 lb gross weight, standard day, sea level unless otherwise noted</i>		
■ Maximum speed (V _{NE})	195 kts	361 km/hr
■ Maximum cruise speed (V _H)	149 kts	276 km/hr
■ Maximum rate of climb	2,250 ft/min	11.43 m/sec
■ Service ceiling	13,200 ft	4,021 m
■ Hover ceiling, out of ground effect	4,300 ft	1,311 m
■ Hover ceiling, in ground effect	9,000 ft	2,743 m
■ OEI service ceiling	3,700 ft	1,128 m
■ Range at Long Range Cruise Speed*		
- Internal fuel	248 nm	460 km
- Internal fuel plus two 230 US gallon external aux tanks	591 nm	1,095 km

* 4,000 feet, 132 knots, 20-minute reserve

Table 2. Black Hawk's weights and performance. From Ref. [Sikorsky, 2000].

DIMENSIONS		
■ Overall length	64.83 ft	19.76 m
■ Overall width	53.67 ft	16.36 m
■ Overall height	17.50 ft	5.33 m
■ Fuselage length	50.04 ft	15.26 m
■ Fuselage width	14.33 ft	4.37 m
■ Folded length *	41.33 ft	12.60 m
■ Folded width *	9.72 ft	2.96 m
■ Folded height *	8.98 ft	2.74 m
■ Wheel base	28.92 ft	8.82 m
■ Main wheel tread	8.88 ft	2.71 m

ROTORS		
■ Main rotor diameter	53.67 ft	16.36 m
■ Tail rotor diameter	11.00 ft	3.35 m

* Air transport configuration: main rotor hub lowered, main rotor blades, stabilator and tail pylon folded.

Table 3. Black Hawk's specifications. From Ref. [Sikorsky, 2000].

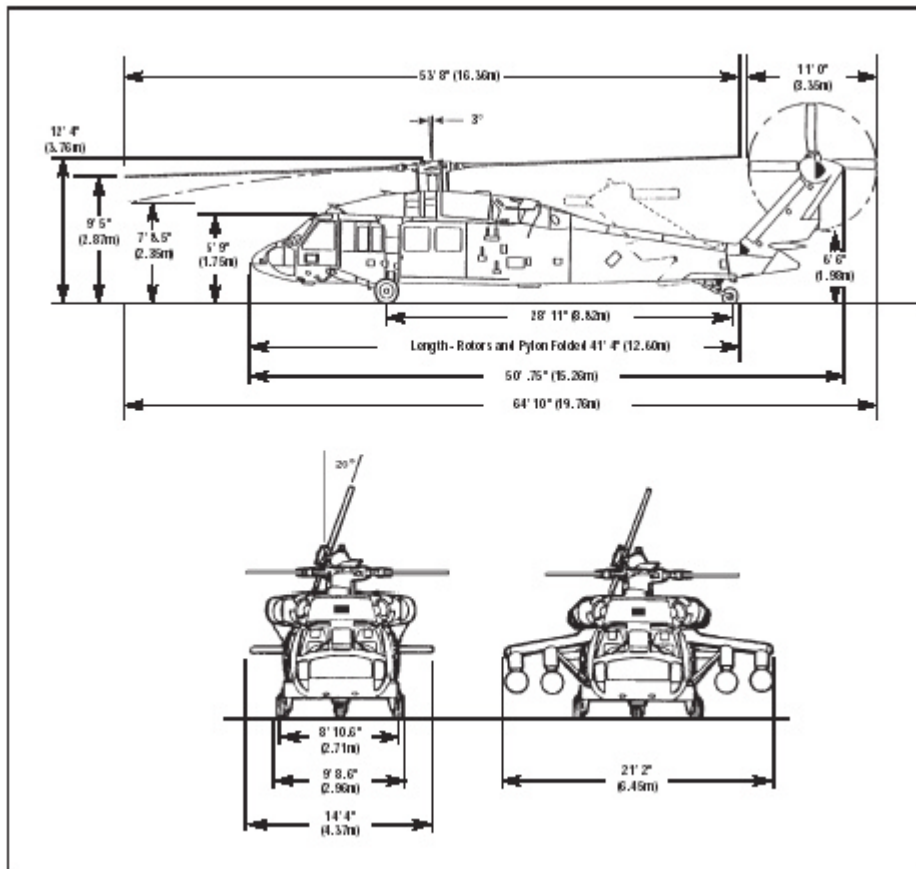

Figure 12. Black Hawk dimensions. From Ref. [Sikorsky, 2000].

GENERAL DATA		
■ Cabin length	12.58 ft	3.84 m
■ Cabin width	7.00 ft	2.14 m
■ Cabin height	4.50 ft	1.37 m
■ Cabin area	88.00 sq ft	8.18 sq m
■ Cabin volume	396.00 cu ft	11.22 cu m
■ Storage compartment volume	20.34 cu ft	0.58 cu m
■ Capacity, normal	12 passengers plus 2 pilots	
■ Capacity, maximum	20 passengers plus 2 pilots	

Table 4. Black Hawk cabin dimensions/capacity. From Ref. [Sikorsky, 2000].



Figure 13. UH-60 Black Hawk. From Ref. [Sikorsky, 2000].

F. CONCLUSION

Although there are many commercial 3D games with helicopter capability, none of them have incorporated the combination of realism and third person viewpoint that is desired in this research. A basic understanding of helicopter flight has been attained through consideration of the various parts of a helicopter and the forces acting on those parts.

III. SYSTEM DESIGN AND ARCHITECTURE

A. INTRODUCTION

Chapters I and II discussed the many factors and important characteristics of a helicopter physics system designed for the Army Game 3D action game. This chapter addresses the methodology and design of a helicopter physics system that addresses these requirements. The modules are as generic as possible with Chapter IV addressing the specific routines and functions encoding.

B. REQUIREMENTS

The main goal of the system is to provide a helicopter flight capability that is believable to the typical human observer (one who is not a helicopter pilot). A future goal could be to provide a level of fidelity that is believable to helicopter pilots as well.

A supportive secondary goal is to provide the capability for a developer to place navigation type points along a route and the system adjust the helicopter capability to flow through these points.

Finally, the system must be efficient enough not to slow down the running of the game. Modules must be streamlined and optimized to require very little processing time and system resources.

The final product should give developers the ability to arbitrarily evoke realistic helicopter flights by simply placing sequenced navigation points throughout a level. Minor tweaking may be required depending of the actual level the helicopter is inserted into, but it should be a relatively quick and easy process.

C. THE UNREAL SYSTEM

1. General Description

The Unreal engine can be categorized into two types of encoding. The first type is C++ encoding. This is the root layer of the engine and contains most of the generic base level code: networking, collision detection, animation, texturing, etc. These are the modules that need to be executed quickly to be successful. The C++ code allows for quick efficient processing of the code base tasks and is the more efficient of the two

layers of the engine. The other layer of the engine is UnrealScript encoding. This is the higher-level layer and is the lower C++ layer.

2. UnrealScript

Even though the UnrealScript is not as efficient as C++, it is a very powerful tool. It is similar to C++ and has many of the same operators and functions available in most programming languages. However, UnrealScript is a strongly typed language, which can make type casting and recasting challenging, and some times impossible. Notwithstanding this, the UnrealScript can invoke functions in the lower code base, thus capitalizing on the efficiency of the pre-compiled C++ code. The script can also be activated by specific events generated by the C++ Code base. Unlike the C++ code base, UnrealScript is not compiled and then run. The script is interpreted in real time. This is what makes the script less efficient than the code base layer. Even so, the UnrealScript provides many abstractions and functions that reduce the amount of coding required at the code base layer. Thus, despite its limitations, UnrealScript is a very powerful and useful programming language.

3. Unreal Virtual Environment

UnrealScript is used to build the Unreal virtual environment. This environment is built from base entities called classes. The most basic of these script classes is called *Object*. *Object* is like the building block for more useful, higher level classes. An *Object* has no appearance, location, or interface with the world clock. Thus, it is prohibitive to use objects in this research, other than as a building block for higher-level classes.

A much more capable subclass of *Object* is the *Actor* script class. It has everything that the *Object* is missing: velocity, location, world clock interface, etc. However, with this added functionality comes more over-head. *Actors* require more storage space than *Objects*. *Actors* are used to represent most things in the world with the exception of things that can be controlled either by a human player or by artificial intelligence (AI). Hence, buildings, trees, poles, and the like would be actors.

Finally, the things in the Unreal world that are controlled by players/AI is represented by the *Pawn* script class. The *Pawn* script class is a subclass of *Actor* and has a *Controller* script class associated with it. *Controllers* are a subclass of *Actor*. They

determine how a *Pawn* interacts with the Unreal world. The *Controller* keeps track of the physical characteristics of the *Pawn*, processes situational information, as well as interacts with the code base to provide appropriate rendering of graphics and animation. The helicopter class, created for this research, is a subclass of *Pawn*.

4. Limitations

There are a couple of limitations of the Unreal system that directly impacted this research effort. One of the first limitations was the different directional unit used in the system. Directions, in any dimension (X, Y, Z) are represented by numbers from 0 to 65536. Think of this in terms of a circle, with 65536 equal to 2π or 360 degrees. It is unclear as to whether the reason for this scale is because of the systems byte storage size or if someone at the Unreal home office has a sick sense of humor. Nevertheless, this scale is only part of the problem. The rest of the problem comes from the Unreal Systems inconsistency. Sometimes these angles are represented with positive numbers and at other times they are represented as negative numbers. For example if you have a helicopter in the Unreal world and you request rotation information, you may receive: 0 (Pitch), 49152 (Yaw), 0 (Roll). But, if you try to manipulate the yaw directly and request yaw information you would receive a yaw of -16384. As one can imagine, this makes navigation and interpolation difficult.

Another limitation of the system is the apparent mix up of pitch and roll variables. Roll actually controls the pitch and pitch controls the roll. This is not a big problem once you are aware of it. The problem for this thesis was the fact that hours of research time was spent debugging and modifying good code because of this mix up.

Finally, there was not a lot of support available for the unique requirements for this research. Functions to find angles, rotations, and locations are not available. This is compounded by the previously mentioned fact that in several cases, the system has its own unit of measurement, which makes implementing standard math functions challenging. Despite the limitations, it is believed that goals of this research can be accomplished using the Unreal system.

D. CONCEPTUAL DESIGN

Virtual entities (like the helicopter) usually follow some form of the perceive-decide-act concept. Modifying this model leads to the following four module conceptual design:

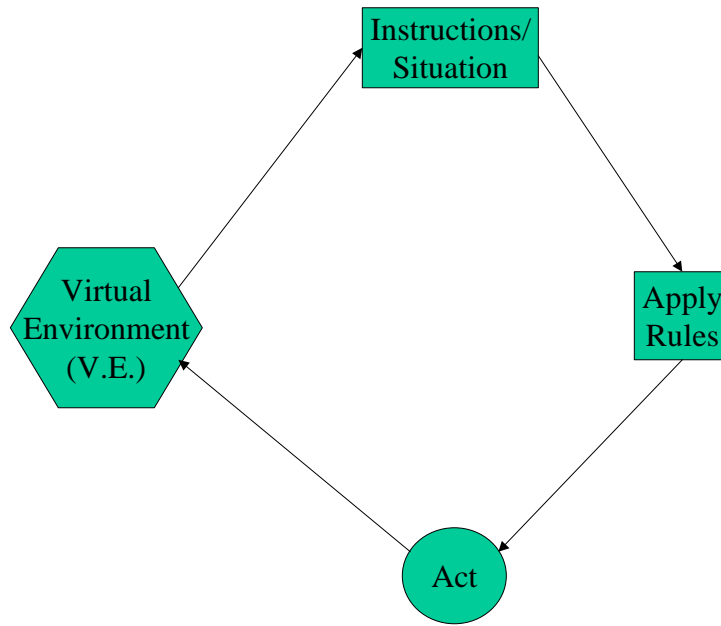

Figure 14. Four Module Physics System Design.

First the virtual environment is created. Next the instructions/situation module determines instructions and current situation. Third, the rules module processes the instructions/situation information and applies rules to them. Finally, the action module receives the results of the rules module and acts accordingly on the virtual environment.

The rest of this section explains what functions are expected in each module of helicopter conceptual design.

1. Virtual Environment

The first module is the virtual environment. This is the representation of the Unreal world to the user/player. This is where the user sees the helicopter moving (or not moving) and interacting with other virtual items. The virtual environment used for this research will be an arbitrary level designed to run on the Unreal engine. The level may contain trees, various terrain features, buildings, roads, etc.

2. Instructions/Situation

The next module in the conceptual design is responsible for giving the helicopter its goals as well as pertinent information about the virtual environment. This module must be comprised of a sub-module for routing/pathing. This sub-module keeps up with where the helicopter is and where it wants to go. The pathing sub-module is responsible for ensuring that the helicopter has a destination as well as an algorithm to get to that destination.

The Instructions/situation module also needs to employ functions that provide information about the virtual environment (situational knowledge). One of these functions must provide distance from destination information. Another function is required to provide direction to destination information. Finally, heading, speed, and orientation information are also made available to this module.

3. Apply Rules

The premise of this research is to provide a rule-based solution for helicopter physics. A virtual helicopter physics system needs to include, as a minimum, two sub-modules: “movement” and “attitude”. Current situation information and instructions are received from the instruction/situation module and processed by the rules’ sub-modules as indicated in the following paragraphs.

The movement methods are critical to the appearance of realism in a virtual helicopter system. The movement sub-module breaks the movement of the helicopter down to two states; move towards and hovering. The move towards state is any state in which the helicopter is moving. Whether it is taking off, landing, flying forwards or backwards, if it is changing location, it is in the movement state.

On the other hand, the hovering state is simply the state where the helicopter is not changing location. While in the hovering state, the helicopter is allowed to pivot on its axis and still be considered to be hovering.

Equally critical to the appearance of realism in a helicopter system are the attitude factors. The attitude sub-module can be broken down into the traditional components of yaw, pitch, and roll. A better understanding of yaw, pitch and roll can be obtained by

considering a log floating in a pond. A person might sit (in the middle) on that log and move around the pond with a paddle. The freedom of movement that allows them to control where the log goes is called yaw. The person can turn left or right to get to a particular point by manipulating the yaw of the log. Now consider if that person moved to the very end of that log. The end would dip down into the water and the opposite end would lift up out of the water. This is the pitch of the log or manipulating the up and down orientation of the log. Finally, consider if that person stood up in the middle of the log and started “log rolling”. Log rolling is usually seen at lumberjack water sport events or Saturday morning cartoons. It is when you stand on a log in water, and run causing the log to roll as you run, hopefully without falling. This is done through manipulation of the roll component of the log. These same components are applied to aviation vehicles also.

To apply these concepts to a helicopter, think of a helicopter flying level to the ground heading due north. The nose of the helicopter turning left or right is called yaw. The nose of the helicopter moving up towards the sky or down towards the ground is called pitch. Now think of the helicopter rolling left on its side or rolling right on its side, this is called roll.

These three components combine together providing the six degrees of freedom needed to position the helicopter in any position. Accordingly, any helicopter position can be completely described by these three basic components.

Finally, an interpolation function will be required to provide transitional information for both the motion and attitude sub-modules. This speaks to the primary requirement for the appearance of realism. Smooth interpolation between physics states is essential to realism in a helicopter physics system.

4. Act

The action module is the point where the information from the rules section is acted on. The appropriate actions are applied and the virtual environment is changed to reflect these changes.

E. CONCLUSION

It is believed that when one attempts to provide realism to a virtual environment, it is a continual process. Since it is impossible to achieve the realism of the real world,

there is always room for improvement in realism and virtual environments. Refinements and improvements will continue to be made to this system long after this initial research effort is concluded.

The primary purpose of this research is to provide, a realistic helicopter physics system for the Army Game Project, which originally had no helicopter physics. This initial system was to provide a proof-of-concept for the physics system information flow model described in the previous paragraphs. With this accomplished, more capabilities and detail can be later added to the system to provide a higher level of fidelity.

The modular design of the system allows for modifications and improvements to be added at specific points without interfering with the operation or code from other modules. Thus, if a better movement algorithm is derived in the future, it can be incorporated without affecting the attitude module. The initial implementation goals for this research are listed in Table 5. Recommendations for future goals/enhancements are addressed in Chapter VI.

Module	Initial Design Goals
<i>Virtual Environment</i>	<ul style="list-style-type: none"> • Detailed level for testing and experiment • Helicopter entity that can be spawned in any Army Game level • Flight path flexibility
<i>Instructions/Situation</i>	<ul style="list-style-type: none"> • Method to gather situational information • Algorithm to determine routing • Helicopter instruction formulation/interpretation
<i>Apply Rules</i>	<ul style="list-style-type: none"> • Algorithm for attitude • Algorithm for movement • Algorithm for smooth interpolation between physics states • Algorithm to detect inappropriate attitudes and movements
<i>Act</i>	<ul style="list-style-type: none"> • Ability to adjust helicopter orientation • Ability to adjust helicopter location • Ability to adjust helicopter velocity/angular velocity

Table 5. Initial Design Goals.

THIS PAGE INTENTIONALLY LEFT BLANK

IV. SYSTEM IMPLEMENTATION

A. INTRODUCTION

The previous chapter focused on the conceptual model for the helicopter physics system. This chapter provides the details of the primary modules in terms of the classes, functions, and code implemented to provide the required functionality.

B. HELICOPTER PHYSICS IMPLEMENTATION

1. *Class Helicopter*

The *Helicopter* class is implemented to achieve the goals of the virtual environment module of the conceptual design. This class handles all the initialization and instantiation of the helicopter entity as well as the virtual world. *Helicopter* communicates through the code base to the hardware, providing instructions on how to render and animate the virtual helicopter entity. Additionally, *Helicopter* identifies the controller for the helicopter entity as well as its properties, i.e. its menu name, if it is static, etc. The *Helicopter* is placed in a level, and thus is able to interact with that level, completing the creation of the virtual environment.

The *Helicopter* class is also the place where the type of helicopter is selected and the capabilities are indicated. As more helicopters are added to the Army's inventory and current helicopter capabilities change, this is the module that must be updated to accurately reflect these advances.

2. *Class HeloController*

The *HeloController* class is implemented to achieve the goals of the remaining three modules of the conceptual design. This class employs several functions and routines that address the goals of the instructions/situation, apply rules and act modules. A few of the more prominent functions will be discussed in the following paragraphs.

The *GetNextTarget* function is responsible for processing route information and providing instructions for the helicopter entity to follow. This functions addresses the goals from the instruction/situation module of the conceptual design.

Additionally, the *Tick* function also goals from the instruction/situation module. *Tick* is basically the simulation engine. It keeps the system flowing from module to module. *Tick* contains code that provides information to other functions as well as gathers information about the virtual world.

The goals of the third module, apply rules, are addressed by several functions and routines. The *Yaw*, *Pitch* and *Roll* routines are very similar to each other. These routines are combined to determine the attitude of the helicopter entity. The *Yaw* routine considers the helicopter entity's current yaw orientation; obtains the current destination location from the *GetNextTarget* function; and uses the *GetDirRot* function to determine the desired yaw orientation. Finally, the *Yaw* routine smoothly interpolates from the current yaw orientation to the desired yaw orientation. The *Yaw* routine has "smart" code, which ensures that it rotates the shortest angle to the desired orientation. In other words, if the current helicopter is yaw oriented at 270 degrees and the desired orientation is 180 degrees, *Yaw* is smart enough to make the 90 degrees left turn to a 180 degrees orientation instead of making the 270 degrees right turn to the 180 degrees orientation.

As stated previously, the *Pitch* and *Roll* routines are very similar to the *Yaw* routine detailed above. The main differences are the fact that each routine represents a different component of the helicopter's orientations. Also, the actual interpolation factors vary from orientation component to component. For example, it may be more desirable for the yaw orientation to change more rapidly than the roll. The angular velocities vary depending upon the maneuver the helicopter is making. So, it follows that the rate of interpolation between the current orientation and the desired orientation will vary by orientation component.

The movement portion of the code is also comprised of several functions and routines. The *Moveto* routine is the most often used part of the code. In order for the helicopter to move, a direction of movement must be determined as well as the speed of the movement. *Moveto* uses current location information in conjunction with destination location information, received from the *GetNextTarget* function, to interpolate between the two locations. Additionally, the velocity of the helicopter entity is factored into the movement process before the helicopter is actually moved to the next location.

It has been determined, that there are certain times in helicopter flight, when it makes more sense for the helicopter to change directions by hovering and then pivoting. For instance, if the next location the helicopter is supposed to travel to is close to 180 degrees from its current orientations. Another, case might be if the distance from the old desired location and the new desired location is so short that it would be more efficient to hover and pivot than to try to curve around. In this case the helicopter would travel more distance and take longer to travel that distance than the shorter straight line distance. Additionally, the current velocity of the helicopter would also be a factor in determining if the distance would warrant a hover versus a fly through.

The *Hover* function has been established, and should be invoked in the situations described above. Additionally, the *badAngle* function is provided to determine if the change in direction of the helicopter is at a “bad angle”, i.e. around 180 degrees difference. Finally, the *pointDist* function is used to calculate the actual distance between the locations for the purposes of determining if it is necessary to invoke *Hover*.

Lastly, after all the previously described determinations, calculations and interpolations are accomplished, the position and orientation of the helicopter entity is updated and the process repeats until the entire path has been traversed by the helicopter in the virtual world.

C. CONCLUSION

The primary goal of the helicopter physics system is to provide realistic helicopter flight in a 3D virtual environment. Another goal is to provide a tool that enables the Army Game designers the capability to incorporate helicopter capabilities by simply placing navigation/path information into a level. This realism is to be at a fidelity level that is believable to the average human (non-helicopter pilot).

The implementation detailed above accomplishes these goals. Although it is believed that a higher level of fidelity could have been achieved by utilizing theories and formulas from the field of aerodynamics, i.e. blade element theory, equipment and processing limitations of the Army Game Project target platform call for compromise between fidelity and hardware limitations. Experiments were conducted to determine

whether or not design goals were achieved. These experiments are described in detail in Chapter V.

V. EXPERIMENT AND RESULTS

A. INTRODUCTION

This chapter discusses the details of the experiments conducted to test the helicopter physics system created for this research. First, the testing process and conceptual design are described in detail. Next the test protocol and results are discussed, followed by conclusions drawn from the results of the experiments.

B. TESTING PHILOSOPHY

The principle goal of this research is to produce realistic helicopter behavior that is believable to the average observer. This desired realism, requires a higher level of fidelity than that usually found in commercial 3D game and modeling systems.

There are several variables that must be considered when determining an experiment participant's ability to recognize realistic helicopter behavior. These variables are considered in the beginning stages of the experimental design.

1. Participant's Helicopter Game Experience

It is believed that the level of a participant's helicopter gaming experience has a direct impact on that participant's ability to gauge realistic helicopter flight. Those participants who have a high level of helicopter game experience will have a larger knowledge base to draw upon when judging the AGP system. This is a double edged sword: on one hand, the participant will be able to better recognize advances made in the AGP system because of his/her experiences with other games; on the other hand, the participant may be used to seeing helicopters, for the sake of entertainment, doing unrealistic behaviors, but he/she does not recognize that these behaviors are unrealistic and he/she expects the same behavior from all virtual helicopters. If enough participants have a high level of helicopter game experience, it may warrant isolation and further study.

2. Participant's Helicopter Experience

As stated previously, this research's goal is to produce helicopter physics that is believable to the typical person. It is clear that a person's experience with helicopters will directly effect how much fidelity is needed to make a helicopter flight believable to

them. The level of experience observed from the participants ranged from those who have only seen a helicopter on TV or the movies, to those who actually fly helicopters for a living, helicopter pilots. Since the scope of this thesis is for third person viewing of a helicopter physics, the participants who have never been on a helicopter ride are probably the most like the target audience for the physics system created.

Notwithstanding the previous, this research attempts to attain a level of fidelity that satisfies all levels of experience except for the highest level, which in this case is helicopter pilot. Since pilots commonly have experience and or access to high dollar specialized flight simulation equipment, in addition to the highest level of fidelity (actual flight) on a regular basis, it is believed that the level of fidelity needed to satisfy them is well beyond the scope of this thesis and the Army Game Project.

3. Helicopter Flight Presentation

As indicated in earlier sections, the Army Game Project's target hardware is the typical PC. Thus the presentation of flights for this research is also limited to typical PC hardware. For the purposes of this research, the participants do not interface with the keyboard or mouse. The participants simply observe the computer monitor. The use of a monitor inherently has limitations. The first limitation is the appearance. Although the Army Game is clearly on the high quality level in computer 3D graphics, the graphics pale in comparison to the real world and even fall far short of video. Additionally, the typical monitor can display 3D representations, but cannot truly display 3D on a 2D screen.

In a like manner, sound, when used, comes from two inexpensive computer speakers located on either side of the viewing gaze. Typically, there is not any spatialization cues that are usually present when watching a helicopter in real life. The participant does not experience surround sound or the vibrations that may be associated with watching a helicopter.

Although there are clear limitation to modeling helicopter physics on the typical PC, it is not evident as to what effects these limitations have on a participant's ability to gauge realistic helicopter flight.

4. Helicopter Flight Content

The flights used in these experiments included only modern United States Army helicopters. The 3D models used were the RAH-66 Comanche and the UH-60A Black Hawk. The helicopter in each flight model would traverse a pre-defined path and make various orientation, elevation and location transitions in order to traverse the assigned path. Additionally, backgrounds and terrain varied from buildings and grass to desert and mountains (except in the Lo_Res version). Finally, generic helicopter sounds were played during the Hi_Res and Vega versions. This sound used was from the Sound Ideas collection, *The Library* (Disc TL 03, track 56).

5. Test Flight

Two test flights were designed for the experiment; Low Resolution (Lo_Res), High Resolution (Hi_Res). The Lo_Res version was included as a baseline to gather participant opinion without any distractions or enhancements. The Lo_Res version consists of a helicopter in the AGP utilizing the new physics system to navigate between pre-placed navigation points. There were no background graphics included, no sound, and the view/navigation points were set to be visible. The researcher hoped to gather data on the realism of the raw physics model without the aid of background and sound to enhance fidelity and realism. This version is to attain a pure barometer, if you will, of the physics system.

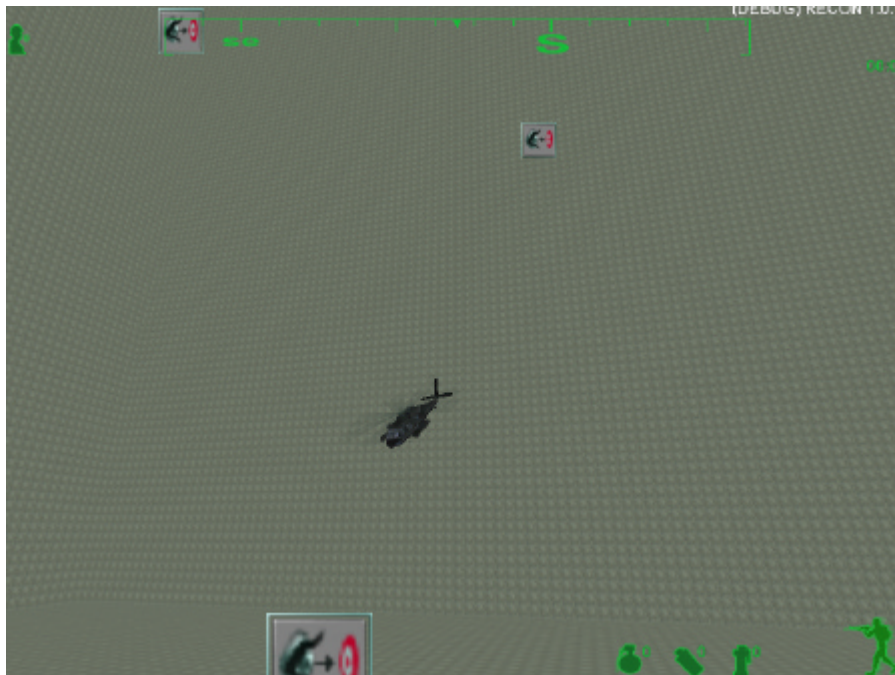

Figure 15. Screen shot of Lo_Res Version of AGP Helicopter Physics.

The Hi_Res version was designed as the bar to access if the complete system has in fact attained the initial research goals. Detailed background images were included as well as the playing of generic helicopter sounds during the flight. Unlike the Lo_Res version, the view/navigation points are not visible in the Hi_Res version.



Figure 16. Screen shot of Hi_Res Version of AGP Helicopter Physics.

6. Control Tool

As mentioned before, a secondary goal of this thesis is to provide the developers of the AGP a tool to provide realistic helicopter physics to the AGP. In order to determine if this goal has been met, a comparison to a commercial tool is required. Thus, participants can compare side-by-side a system designed using the AGP system to a commercial tool like Vega, that provides pathing and spline capabilities. For this purpose, another flight version was designed using Vega. This version is considered to be equivalent for comparison purposes to the Hi_Res AGP version. The same generic helicopter sound is used during the flight of the Vega version. Also, detailed background images are also present in the Vega version. This version was designed to traverse a

route very similar to the Hi_Res version. Both the routes for the Hi_Res and Vega versions have similar turning requirements, elevations changes, and orientation shifts.



Figure 17. Screen shot of Vega Version Helicopter Physics.

7. Control Game

Additionally, in order to access if the primary goal is accomplished, a side-by-side comparison of the AGP system to a high quality commercial 3D game is required. *Enemy Engaged* was the game selected for this comparison. There are some issues in comparing the AGP system to a commercial game at this time. First the AGP system is in development and is designed for 3rd person viewing. The control game mainly shows a God's eye view from behind the helicopter with "canned" 3rd person views in a somewhat fly-by type of mode. Also, the resolution of the control game is different than the AGP system. The viewpoint provides a closer view than currently practical in the AGP system. These factors may taint the responses of the participants. However, since this

experiment is being conducted to illustrate trends and experiment 1 is the primary experiment, this study should provide valuable information despite these discrepancies.



Figure 18. Screen shot of Enemy Engaged Commercial 3D Helicopter Game.

8. Survey

The realism of the created system must be determined from the subjective assessment of the participants in the experiment. Each participant assesses the level of realism in the AGP systems along with the control systems, by comparing what they see in the systems to what they expect to see in a real helicopter flight. Then, this information is analyzed along with participant experience information to draw conclusions and recommend improvements to the AGP system. The surveys used for these experiments can be found in Appendix B.

Although it is believed that a survey is the best approach to attain the needed data for this research, it does come with some cautions. First, there is a chance that participants may answer the questions in a manner as to try to please the researcher. It is believed that by participating in this research, it is trivial to deduce the purpose of the research and thus try to help meet those expectations. However, at least in the case with

the control tool, since the participants know that the AGP and Vega flights were both created by the researcher, it should be less obvious as to what the desired outcome is.

Another problem with a survey is clarity. The participants for the experiment come from a wide variety of backgrounds and disciplines. Although the researcher is available to answer questions, there is no guarantee the participants will inform the researcher when a question is unclear to them. Thus, questions may be answered randomly and thus the results may be tainted.

Notwithstanding the above concerns, it is believed that for the type of information needed for this research, the survey is the best choice to attain this information.

C. PARTICIPANT POOL

Choosing a subject pool is an important part to any experiment. A too small pool may result in insignificant and findings that cannot be generally applied across populations. Contrary, a too large pool may result in a level of variability that may take a separate research effort to try to evaluate. Due to time, network, and system constraints, the pool for this research has been narrowed to two groups; NPS student body and NPS faculty and staff.

1. NPS Student Body

The student body of the Naval Postgraduate School is the larger of the two pools. This will be the primary source of participants for this research. The student body is made up of approximately 1,300 military officers. It can be surmised that many if not most of these officers have seen a real helicopter fly. And many of them have been on a helicopter flight before. Additional advantages to using participants from this pool include accessibility, military experience, and education. The students are all required to participate in various activities on campus and thus are located nearby and available to participate in the experiment with minimal inconvenience. Additionally, the fact that this population consists of military personnel implies that they have a good understanding of the importance of realism and training in the military. Finally, the fact that all the people in this population are pursuing graduate level degrees better the chances of them understanding questions on the survey, or at least their willingness to ask questions if they do not understand.

2. NPS Faculty and Staff

The faculty and staff of the Naval Postgraduate School are the secondary source for participants. This pool is much smaller than the previous, but shares some of its advantages. Availability and military experience are the advantages shared by both these populations. Although the military experience in the case of faculty and staff may just be exposure to the military at NPS. The big advantage of this pool is the fact that it consists of civilians. This gives you a wider range of ages, which allows access to some participants who more closely reflect the target audience for the AGP. There are only a small number of teen-age faculty and staff at NPS, but there are no teen-age officers in the NPS Student body.

D. EXPERIMENT PROTOCOL

The purpose of the experiment was to show that the AGP helicopter physics system was at least as realistic as a system designed with a commercial graphics package and as realistic as a commercial 3D helicopter game. Thus two experiments were conducted. One attempted to compare the two similar flights: one created with AGP system and one created with Vega. The other experiment, attempted to compare two flights: one in the AGP and one in *Enemy Engaged*.

1. Preparation

First, a basic level was created to provide the virtual environment for the Lo_Res version of the Army Game. The UH-60A Black Hawk was used as the helicopter in this level. The level consisted of a grey background with no additional graphics. Again, the navigation/view points were allowed to be visible, thus allowing some cues as to what the helicopter would be doing and to provide some points of reference for the helicopter movement.

Next, a more detailed level was selected and modified to provide the virtual environment for the Hi_Res version of the Army Game. Again, the UH-60A Black Hawk was used as the helicopter in this level. This level contained many background details. It had terrain features, trees, buildings, roads, and other distinguishing graphics.

Accordingly, a scene/level was created in Vega to be used as the control case tool. This scene was designed to be appropriately similar to the Army Game Hi_Res level.

This level was designed with a RAH-66 Comanche as the helicopter. It is believed that using a different military helicopter provides for similarities between the Vega version and the Hi_Res version, but also helps prevent confusing the two versions. This level also contained many background details. It had grass, roads, buildings, trees, and other prominent graphics.

Enemy Engaged was chosen to be the control case game. Like the Vega version, this game provided the desired similarities to the Army Game Hi_Res level. The RAH-66 Comanche is also used as the helicopter in the control case game. The game also included a wide variety of background graphics to include terrain features, buildings, roads and vegetation.

The Vega version or control tool was run on a Dell Inspiron 8100 (laptop), Pentium III 1 GHz machine with 256 MB RAM running an NVIDIA GeForce 2 GO Graphics card with 16MB of memory. The monitor used was a Dell 1700FP, 17 inch flat panel display.

Both AGP versions (Hi_Res and Lo_Res), and *Enemy Engaged* (Control Game) were run on a Dell Dimension 4100 (desktop), Pentium III 1 GHz machine with 512MB RAM running an NVIDIA GeForce 2 card with 32MB of memory. The display used was a ViewSonic 19 inch Graphic Series G800 monitor.

Although it was desirable to have all the versions run on the same equipment, due to licensing issues, the Vega version could not be placed on the primary equipment. Notwithstanding this issue, the researcher determined that no visible difference could be seen from running the Vega version on a computer equivalent to the desktop versus the laptop. Additionally, the same manufacturer, Dell, produced all the computers used in the experiments. The Desktop system had twice as much RAM and video memory as the laptop system, but the Vega version does not require more memory than was available on the laptop. Thus, it is surmised that additional memory on the laptop would not have been used or needed during the experiment.

Additionally, although different monitors were used, since the smaller monitor was a flat panel, it is suggested that the amount of viewable area on both monitors are

negligibly different. In fact, only the control case game used the full screen. The other versions used a window that was smaller than either monitor's viewable area.

Notwithstanding the previous discussion, it is believed that the equipment differences will have an insignificant impact on the outcome of the experiments. However, it is not known for certain what impact these differences may or may not have.

2. Introduction

Participants were brought into the testing area individually. Only one subject participated in the testing process at a time. Next each participant was given an introduction to the experiment and testing procedures to read. After reading the introduction each participant was given a short verbal brief and asked to sign the appropriate participant consent forms and privacy act statement. The participants were informed that they were participating in an experiment to compare a product under development for the Army Game to commercially available products. Finally, each participant was asked to sit in a chair with both machines (laptop and desktop) on either side. The order in which the participants viewed the different versions was randomized according to the time slots each participant signed up to participate in.

3. Tool Experiment

The goal of the first experiment was to compare the realism of a helicopter flight created on the system developed for the Army Game to that of a flight created on a commercially available system. As noted previously, it is hoped that the fact that the researcher created both versions, would reduce the participants' tendency to skew answers to please the researcher. In order to provide a baseline for what the a virtual flight without realism is, each participant was allowed to view an Army Game version without physics for a half minute before the actual experiment began.



Figure 19. Screen shot of No_Physics Version of AGP Helicopter Physics.

a. Control Case

The participants were given a brief introduction to what they were about to experience/observe. Next, general helicopter sounds were played and the Vega version was loaded. The participants were allowed to watch the flight for 2 minutes and then the simulation was stopped.

b. Test Case 1

The participants were given a brief introduction to what they were about to experience/observe. Next, general helicopter sounds were played and the Army Game Hi_Res version was loaded. The participants were allowed to watch the flight for 2 minutes and then the simulation was stopped.

c. Test Case 2

The participants were given a brief introduction to what they were about to experience/observe. Next, Army Game Lo_Res version was loaded (no sound). The participants were allowed to watch the flight for 1 minutes and then the simulation was stopped.

d. Survey

After viewing all three versions, each participant was given a survey form to complete (see Appendix B). The participant was allowed to complete the survey at his/her own pace. The researcher remained in the nearby area and was available to answer any questions the participant may have had. The researcher was limited to answer questions only to clarify the questions on the survey. However, the researcher was not allowed to provide any other guidance. Once completed, the survey was given to the researcher and the testing process was complete. The participants were allowed to ask other questions and make comments not pertinent to the survey after the testing process had ended. This additional information was considered and has influenced the suggestions for future work addressed in Chapter VI.

4. Game Experiment

The goal of the second experiment is to compare the realism of the helicopter flights in the Army Game to the realism of the helicopter flights in a commercial 3D Game. Since the Army Game is a 3D game, it is important to determine how a physics system developed for the game compares to that of commercially available games. To provide a baseline for realism, each participant was allowed to view a video of a military helicopter in flight for 1 minute before the actual experiment began.

a. Control Case

The participants were given a brief introduction to what they were about to experience/observe. Next, the *Enemy Engaged* (campaign) free flight mode was loaded. The participants were allowed to watch the flight for 2 minutes and then the simulation was stopped. The game only allows for limited control of the view or camera angles. Thus only two modes were available; tether-follow and fly-by.

The tether-follow mode provides a view behind and slightly above the helicopter. The fly-by mode allows for a series of camera fly-by views at different angles and positions to the helicopter. Unfortunately these views are random and often reflect camera movement, not helicopter movement. It is unclear as to if the randomness of fly-by view or limitations of views in general have any negative effects on this research.

b. Test Case

The participants were given a brief introduction to what they were about to experience/observe. Next, general helicopter sounds were played and the Army Game Hi_Res version was loaded. The participants were allowed to watch the flight for 2 minutes and then the simulation was stopped.

c. Survey

After viewing both games, each participant was given a survey form to complete (see Appendix B). The participant was allowed to complete the survey at his/her own pace. The researcher remained in the nearby area and was available to answer any questions the participant may have had. The researcher was limited to answer questions only to clarify the questions on the survey. However, the researcher was not allowed to provide any other guidance. Once completed, the survey was given to the researcher and the testing process was complete. The participants were allowed to ask other questions and make comments not pertinent to the survey after the testing process had ended. This additional information was considered and has influenced the suggestions for future work addressed in Chapter VI.

E. RESULTS

This section describes the details of the data collected from the surveys completed by each of the participants. In addition, the researcher attempts to draw meaningful associations through close examination of the experiment data.

1. Demographics

The first eight items on the survey were designed to obtain personal information from the participants. Information on possibly relevant factors such as age, sex, helicopter gaming experience, helicopter experience, motion capture and graphics experience were collected and scrutinized by the researcher. It is hoped that any trends in the participants' responses could be illuminated through the collection of this data. Although it is believed that these factors should not significantly affect a participant's ability to gauge realistic helicopter behavior, it is purported that these factors may reveal why some certain participants might require a significantly higher level of fidelity than others. The obvious example is that of a helicopter pilot. As stated previously, a pilot would require a much higher level of fidelity than the average person. And that level of

fidelity is beyond the scope of this thesis. It is expected that pilots give a low rating to all but the highest fidelity simulations. Thus, knowing if a participant is a helicopter pilot will allow for special consideration and a better understanding of the ratings received from that participant. Although pilots are not the target audience for this research, their input and opinions are relevant and they are not excluded from participation in the experiments.

Also, it is important to ascertain a general understanding of each participants experience with helicopters. Although unlikely, if a person has never or rarely seen a helicopter fly, then that person's perception on what a realistic helicopter flight should look like would be significantly less accurate than a person with more helicopter familiarity.

Finally, the participants experience with graphics and motion capture may also have positive or negative affects on their assessment of the realism. They may use their experience to assess what the flight should look like in lieu of their own knowledge and expectations in terms of a real helicopter flight. Participants who play helicopter type games also have this same potential for tainting their responses.

Again, although this type of data is being collected to aid in identifying trends in the responses from participants, it is unclear at this time as to the actual affects any one or all of these factors have on the participants' abilities to judge realism of the systems presented.

2. Assessment of the Realism of the Helicopter Physics: Experiment 1

Once the participants finished watching all three versions of the helicopter flights, they were asked to complete a survey that asked them to grade the realism of each system. The participants were asked to assess the realism by grading the flights in three areas, as well as two areas that addressed overall realism and personal expectation. The five areas are listed below in table 6. and also on the survey form in Appendix B.

Area	Explanation
Orientation Transitions	Pivoting: pointing nose of craft in different directions
Elevation Transitions	Climbing or Descending
Banking	Changing direction of motion by rolling the body of the craft
Overall Realism	Bottom-Line: How realistic is the flight
Expectation Satisfaction	Did the realism meet your expectations for a video game

Table 6. Survey Grading Criterion.

The five areas listed above were graded by each participant using the following criterion: *Didn't Notice, Totally Unrealistic, Mostly Unrealistic, Moderately Realistic, Very Realistic, Totally Realistic*. These criteria are enumerated using discrete numbers from zero to five respectively. Because the participants are rating all three versions side-by-side, it is surmised that they are ranking each version against the others. Thus it is pertinent to assess the rankings of a system in isolation as well as in relation to the rankings of the other systems.

3. General Results: Experiment 1

The summarized results of the surveys are illustrated below in Tables 7 thru 12. Each table (7 thru 10) consists of three rows. The first row indicates the category type and response received. The second row indicates the number of participants who chose a particular response. And the last row indicates what percentage of the total population chose a particular response. Both Tables 11 and 12 have some percentages in parenthesis. This indicates that some of the participants did not rate the systems in a particular area and thus the percentages indicated in the parenthesis do not include those individuals. For example, if there are nineteen participants, but one of them did not observe the banking of the helicopter in the Army Game Hi_Res version and thus could not rate the realism in that area, that person would not count towards the total number of respondents in that area. Thus if eight of the participants rated the Hi_Res version better than the Vega version in *banking*, the percentage rate would be calculated by dividing eight by eighteen instead of dividing eight by nineteen, resulting in 44% instead of 42%.

Although a large amount of data was collected, the tables only summarize the data that is pertinent to the goals of this research. Thus the data collected on the commercial system is only used to compare that system to the test system. Whereas, the data collected on the test system is being considered in comparison with the control system as well as on its own merits.

Age	16-21	22-27	28-33	34-39	40 and up
# of Subjects	2	2	7	6	2
% of Subjects	10.5%	10.5%	37%	31.5%	10.5%

Table 7. Distribution of Participants by Age.

Gender	Male	Female
# of Subjects	18	1
% of Subjects	95%	5%

Table 8. Distribution of Participants by Gender.

Helicopter Game Playing Frequency	Never	Once or Twice	Monthly	Weekly	Daily
# of Subjects	12	6	1	0	0
% of Subjects	63%	32%	5%	0%	0%

Table 9. Distribution of Participants by Game Experience.

Relevant Experience	Helicopter Pilot	Ridden in Helicopter	Seen a Helicopter	Graphics/Motion Capture
# of Subjects	2	16	19	8
% of Subjects	11%	84%	100%	42%

Table 10. Distribution of Participants by Experience.

<u>Army Game Hi_Res Rating</u>	Totally Unrealistic	Mostly Unrealistic	Moderately Realistic	Very Realistic	Totally Realistic	Didn't Notice
Area						
<i>Orientation Transitions</i>	1 5%	1 5%	9 47%	5 27%	3 16%	0 0%
<i>Altitude Transitions</i>	1 (6%)	2 11%	4 (22%)	11 (61%)	0 0%	1 5%
<i>Banking</i>	2 (11.5%)	1 (6%)	8 (47%)	4 (24%)	2 (11.5%)	2 10.5%
<i>Overall Realism</i>	1 5%	2 10.5%	6 32%	8 42%	2 10.5%	0 0%
<u>Rating</u>	Totally Not Met	Mostly Not Met	Moderately Met	Mostly Met	Totally Met	Don't Know
Area						
<i>Met Expectations</i>	0 0%	3 15.5%	5 27%	8 42%	3 15.5%	0 0%

Table 11. Participants ratings of Army Game Hi_Res Physics.

<u>Realism Rating of Army Game Hi Res System Compared to Vega System</u>	Better	Equal	Worse
<u>Area</u>			
<i>Orientation Transitions</i>	13 68%	6 32%	0 0%
<i>Altitude Transitions</i>	10 (56%)	6 (33%)	2 (11%)
<i>Banking</i>	11 (65%)	5 (29%)	1 (6%)
<i>Overall Realism</i>	13 68%	6 32%	0 0%
<i>Met Expectations</i>	14 74%	5 26%	0 0%

Table 12. Army Game Hi_Res Realism Ratings Relative to Vega Realism Ratings.

Although detailed statistical analysis was not performed on the data collected due to the impracticality associated with a small sample size, the design of the survey was shrewd enough to highlight emerging trends embedded in the data. Overall, 53% of the participants found the Army Game Hi_Res system to be very to totally realistic. Even more encouraging, 58% of the participants indicated that the system mostly to totally met their expectations for realism in a video game. Considering the fact that 11% of the participants were helicopter pilots and not expected to find the system realistic, the relative percentages are even better than those that have been reported.

Since rating the realism is a subjective process, it is even more important to compare the Army Game system to one produced with commercial tools. It is hoped that by comparing the systems, more tangible conclusions can be supported. On average, 68% of the participants rated the Hi_Res version better than the Vega version. In addition, the remaining 32% of the participants rated the system equal to the Vega system. None of the participants rated the Army Game Hi_Res system's realism as worse than the Vega system's realism. Likewise, 72% of the participants indicated that the Hi_Res system's realism met their expectations better than the Vega system's realism. Again, none of the respondents rated the Vega system's realism as better than the Army Game Hi_Res system's realism. Once again, considering that 11% of the participants were helicopter pilots, these findings are encouraging if not statistically

impeachable. In the context of the purposes and goals of this thesis, these findings and figures are indicators of the success for this research effort.

Since the results of experiment 1 were so encouraging, it is desirable to further evaluate the system by comparing it to a commercial 3D game. It is believed that the results of experiment 1 provided enough positive trends to be considered proof of concept. However, it is hoped that by conducting experiment 2, further support of the goals of this research effort will be discovered.

4. Assessment of the Realism of the Helicopter Physics: Experiment 2

Once the participants finished watching both games, they were asked to complete a survey that asked them to grade the realism of each system. The participants, as in the first experiment, were asked to assess the realism by grading the flights in three areas, as well as two areas that addressed overall realism and personal expectation. The five areas are summarized in Table 6.

5. General Results: Experiment 2

Like tables 7 thru 12 for the first experiment, the summarized results of the surveys from the second experiment are illustrated below in Tables 13 thru 18.

Age	16-21	22-27	28-33	34-39	40 and up
# of Subjects	0	1	0	4	2
% of Subjects	0%	14%	0%	57%	29%

Table 13. Distribution of Participants by Age.

Gender	Male	Female
# of Subjects	5	2
% of Subjects	71%	29%

Table 14. Distribution of Participants by Gender.

Helicopter Game Playing Frequency	Never	Once or Twice	Monthly	Weekly	Daily
# of Subjects	3	4	0	0	0
% of Subjects	43%	57%	0%	0%	0%

Table 15. Distribution of Participants by Game Experience.

Relevant Experience	Helicopter Pilot	Ridden in Helicopter	Seen a Helicopter	Graphics/Motion Capture
# of Subjects	1	3	7	1
% of Subjects	14%	43%	100%	14%

Table 16. Distribution of Participants by Experience.

<u>Army Game Hi Res Rating</u>	Totally Unrealistic	Mostly Unrealistic	Moderately Realistic	Very Realistic	Totally Realistic	Didn't Notice
Area						
<i>Orientation Transitions</i>	0 0%	0 0%	3 43%	3 43%	1 14%	0 0%
<i>Altitude Transitions</i>	0 0%	1 (17%)	0 0%	5 (83%)	0 0%	1 14%
<i>Banking</i>	0 0%	1 (17%)	3 (50%)	2 (33%)	0 0%	1 14%
<i>Overall Realism</i>	0 0%	0 0%	2 29%	5 71%	0 0%	0 0%
<u>Rating</u>	Totally Not Met	Mostly Not Met	Moderately Met	Mostly Met	Totally Met	Don't Know
Area						
<i>Met Expectations</i>	0 0%	0 0%	1 (17%)	1 (17%)	4 (66%)	1 14%

Table 17. Participants ratings of Army Game Hi_Res Physics.

<u>Realism Rating of Army Game Hi Res System Compared to Enemy Engaged System</u>	Better	Equal	Worse
<u>Area</u>			
<i>Orientation Transitions</i>	4 57%	1 14%	2 29%
<i>Altitude Transitions</i>	2 (33%)	3 (50%)	1 (17%)
<i>Banking</i>	3 (50%)	0 (0%)	3 (50%)
<i>Overall Realism</i>	4 57%	2 29%	1 14%
<i>Met Expectations</i>	4 (66%)	1 (17%)	1 (17%)

Table 18. Army Game Hi_Res Realism Ratings Relative to Enemy Engaged Ratings.

As in experiment one, detailed statistical analysis was not performed on this data collected due to the small sample size. However, once again the design of the survey allowed for emerging trends to be identified. Overall, 71% of the participants found the Army Game Hi_Res system to be very realistic. Even more encouraging, 83% of the participants indicated that the system mostly to totally met their expectations for realism in a video game (66% totally met).

Overall, 86% of the participants rated the Hi_Res version equal to or better than the Enemy Engaged version (57% better). Likewise, 83% of the participants indicated that the Hi_Res system's realism met their expectations equal to or better than the Enemy Engaged system's realism (66% better). It is important to emphasize the fact that we have compared a commercial game produced by a seasoned game development company, RazorWorks/Empire, to a game under development at a military school, NPS. With this in mind, even being rated equal to the commercial game is considered to be proof of concept/success for the goals of this thesis.

F. CONCLUSIONS

Although statistically sound significance cannot be determined from the results of the experiments conducted, the trends indicate a clear success in accomplishing the goals

of this thesis. Considering that a developmental tool/game is being compared to finished commercial products and fairing well, and recognizing the fact that many more improvements have been made to the system since the experiments were conducted, the goals of this thesis are a marked success. Finally comments and observations made by participants have been considered and areas for future work are addressed in Chapter VI.

VI. CONCLUSIONS AND FUTURE WORK

A. INTRODUCTION

Although this research effort has been determined to have successfully met its original goals, there are still many areas that can be further developed and improved upon. This chapter addresses those areas, taking into account improvements outside the scope of this thesis in addition to areas for improvement suggested from the participants in the research.

B. FUTURE WORK

1. Further Testing

As already indicated, the sample sizes used in this research did not allow for detailed statistical analysis. It is recommended that a future study be conducted with a study size that would allow for conclusions and generalizations to be projected across the entire target audience for the Army Game. It is important to realize that due to inherent differences between the game used in Experiment 2 and the AGP Hi_Res game, the results may not be entirely indicative of the general population. It is also recommended that once the physics system is implemented into the final production version of the game, that it be again compared against any of the best commercial helicopter games available at that time.

2. Optimization

The code produced for this research is a result of the efforts of the researcher's attempt to obtain a Masters degree at the Naval Postgraduate School. The researcher is not a professional programmer and had to divide his time among programming, researching, experimenting, and writing this document. Thus, it is felt that the code produced has room for optimization by a professional programmer. To this point, duplicate code can be streamlined into functions. Also, after careful scrutiny, many of the routines and functions used might be more efficiently implemented or arranged. For example, it may be hypothetically more efficient to process orientation calculations before calculating movement calculations. These questions and theories can be derived and tested to improve the performance and fidelity of the target system.

3. Implementing More Modules

There are other modules and factors that can be implemented to add to the realism and settings for the helicopter physics system. Skeleton modules have been included in the code for the modules recommended below. Future developer will need to insert the appropriate code and routines to activate these modules:

- Weather Effects (wind, rain, snow, clear, overcast, etc)
- Time of Day (dusk, dawn, day, night, etc)
- Operational Constraints (AI)
- Path Planning (AI)

4. Increase Fidelity

Although it has been conceded that the highest level of fidelity is impractical to pursue, it is practical to strive to attain a higher level of fidelity than currently exists. The current level of fidelity satisfies the goals of this research, and match and exceed that of a commercial 3D game, but within the constraints of practicality, it is desirable to increase the fidelity level even more. The some of the additional modules mentioned in the previous paragraph could be a means to this end. Additionally, more detailed backgrounds, coordinated specialized sounds, and improved camera techniques are also avenues to potentially increase the fidelity of the model. Although the helicopter itself is very important to the fidelity of the model, it is only one part of the virtual environment and many other factors will contribute to the users' perception of the realism of the helicopter flight. Examination of these factors may also illuminate areas for further improvements to the system's current level of fidelity.

5. More Helicopter Models

An obvious direction for the AGP will be to add more helicopter models into the game. The U.S. Army has a variety of helicopters each designed to do a specific mission. Below is a list of the recommended additions to the game the words in parenthesis indicate the primary mission of the helicopter:

- CH-47D/E/F Chinook (heavy lift)
- OH-58D Kiowa Warrior (scout)
- AH-64D Apache (attack)

- RAH-66 Comanche (attack)

C. CONCLUSION

As this chapter illustrates, there are many areas for improvement and refinement in the Army Game helicopter physics system. However, this system has attained the goals of this research effort. The system has shown that it is possible to design a rule-based system that smoothly interpolates between physics states within the bounds of helicopter capability, with the appearance of realism. This research has also shown that the system created is considered to be on the same level or at a higher level than widely accepted commercially produced systems.

THIS PAGE INTENTIONALLY LEFT BLANK

APPENDIX A

A. INTRODUCTION

The source code for the helicopter physics system and associated files consists of thousands of lines of code. This point is exacerbated by the fact that this code highly relies on the Unreal base code, which cannot be published by this institution, due to its proprietary nature.

However, the code created in this thesis is available for public release by contacting the MOVES Institute at the Naval Postgraduate School. Please contact the Army Game Project Manager at staff@armygame.com, or the MOVES Institute Director, Dr. Zyda at Zyda@movesintitute.org.

THIS PAGE INTENTIONALLY LEFT BLANK

APPENDIX B

A. INTRODUCTION

This illustrates the forms used in the experiments described in Chapter V. Additionally, the formatted raw data obtained during the above mentioned experiments is provided. The following list outlines the organization of this appendix:

- Participant Consent Form
- Minimal Risk Consent Form
- Privacy Act Statement
- Experiment 1 Introduction Briefing
- Experiment 2 Introduction Briefing
- Helicopter Physics Game Realism Survey: Experiment 1
- Helicopter Physics Game Realism Survey: Experiment 2
- Survey Results: Experiment 1
- Survey Results: Experiment 2

PARTICIPANT CONSENT FORM

1. **Introduction.** You are invited to participate in a study to compare the realism of helicopter physics provided by a commercial graphics package to that of a new game under development at the Naval Postgraduate School. You will watch three helicopter flights and then be asked to compare the flights on a short survey. We ask you to read and sign this form indicating that you agree to be in the study. Please ask any questions you may have before signing.
2. **Background Information.** Data is being collected by the Naval Postgraduate School Modeling, Virtual Environments and Simulations Institute to provide feedback for Implementing Realistic Helicopter Physics in 3D Game Environments.
3. **Procedures.** If you agree to participate in this study, the researcher will explain the tasks in detail. You will observe three helicopter flights on the computer and then asked to complete a survey comparing the three flights. The entire process will take approximately 20 minutes.
4. **Risks and Benefits.** This research involves no risks or discomforts greater than those encountered in an ordinary computer use. The benefits to the participants will be to contribute to current research in advancing physics design in dynamic virtual environments.
5. **Compensation.** No tangible reward will be given. If desired, a copy of the results will be available to you at the conclusion of the experiment.
6. **Confidentiality.** The records of this study will be kept confidential. No information will be publicly accessible which could identify you as a participant.
7. **Voluntary Nature of the Study.** If you agree to participate, you are free to withdraw from the study at any time without prejudice. You will be provided a copy of this form for your records.
8. **Points of Contact.** If you have any further questions or comments after the completion of the study, you may contact the research supervisor, Dr. Michael Zyda (831) 656-2305 zyda@nps.navy.mil.
9. **Statement of Consent.** I have read the above information. I have asked all questions and have had my questions answered. I agree to participate in this study.

Participant's Signature

Date

Researcher's Signature

Date

MINIMAL RISK CONSENT STATEMENT

**NAVAL POSTGRADUATE SCHOOL, MONTEREY, CA 93943
MINIMAL RISK CONSENT STATEMENT**

Participant:

**VOLUNTARY CONSENT TO BE A RESEARCH PARTICIPANT IN:
EMPLEMENTING REALISTIC HELICOPTER PHYSICS IN 3D GAME
ENVIRONMENTS**

1. I have read, understand and been provided "Information for Participants" that provides the details of the below acknowledgments.
2. I understand that this project involves research. An explanation of the purposes of the research, a description of procedures to be used, identification of experimental procedures, and the extended duration of my participation have been provided to me.
3. I understand that this project does not involve more than minimal risk. I have been informed of any reasonably foreseeable risks or discomforts to me.
4. I have been informed of any benefits to me or to others that may reasonably be expected from the research.
5. I have signed a statement describing the extent to which confidentiality of records identifying me will be maintained.
6. I have been informed of any compensation and/or medical treatments available if injury occurs and is so, what they consist of, or where further information may be obtained.
7. I understand that my participation in this project is voluntary, refusal to participate will involve no penalty or loss of benefits to which I am otherwise entitled. I also understand that I may discontinue participation at any time without penalty or loss of benefits to which I am otherwise entitled.
8. I understand that the individual to contact should I need answers to pertinent questions about the research is Dr. Michael Zyda, Principal Investigator, and about my rights as a research participant or concerning a research related injury is the Modeling Virtual Environments and Simulation Chairman. A full and responsive discussion of the elements of this project and my consent has taken place.

Signature of Principal Investigator

Date

Signature of Volunteer

Date

PRIVACY ACT STATEMENT

**NAVAL POSTGRADUATE SCHOOL, MONTEREY, CA 93943
PRIVACY ACT STATEMENT**

- 1. Authority: Naval Instruction

- 2. Purpose: Implementing Realistic Helicopter Physics in 3D Game Environments.

- 3. Use: Survey data will be used for statistical analysis by the Departments of the Navy and Defense, and other U.S. Government agencies, provided this use is compatible with the purpose for which the information was collected. Use of the information may be granted to legitimate non-government agencies or individuals by the Naval Postgraduate School in accordance with the provisions of the Freedom of Information Act.

- 4. Disclosure/Confidentiality:
 - a. I have been assured that my privacy will be safeguarded. I will be assigned a control or code number which thereafter will be the only identifying entry on any of the research records. The Principal Investigator will maintain the cross-reference between name and control number. It will be decoded only when beneficial to me or if some circumstances, which is not apparent at this time, would make it clear that decoding would enhance the value of the research data. In all cases, the provisions of the Privacy Act Statement will be honored.

 - b. I understand that a record of the information contained in this Consent Statement or derived from the experiment described herein will be retained permanently at the Naval Postgraduate School or by higher authority. I voluntarily agree to its disclosure to agencies or individuals indicated in paragraph 3 and I have been informed that failure to agree to such disclosure may negate the purpose for which the experiment was conducted.

 - c. I also understand that disclosure of the requested information, including my Social Security Number, is voluntary.

Signature of Volunteer	Name, Grade/Rank (if applicable)	DOB	SSN	Date
------------------------	----------------------------------	-----	-----	------

Signature of Witness	Date
----------------------	------

Helicopter Physics Experiment #1 Briefing

Introduction: Thank you for participating in this study. The purpose of this study is to compare helicopter flight physics designed for the Army Game Project to that of physics designed from a commercial graphics package.

Methods: You will observe four helicopter flights on the computer: Army Game (no physics), Army Game Lo-Res(physics), Army Game Hi-Res(physics), and Vega (physics). The purpose of the no physics version is to give you a baseline to start from in addition to your own knowledge of appropriate helicopter physics behavior.

Analysis: You will be asked to complete a short survey that will be used to determine your perception of the realism of each flight you observed.

Administration: The entire process should take about 20 minutes, including the consent forms that must be completed prior to participation in the study.

Propaganda: Your input might be used to help shape future releases of the popular action game America's Army!

Thank you and good Luck!

Helicopter Physics Experiment #2 Briefing

Introduction: Thank you for participating in this study. The purpose of this study is to compare helicopter flight physics under development for the Army Game Project to that of physics in a commercial 3D helicopter game.

Methods: You will observe three helicopter flights one on the television (real helicopter flight) and two on the computer: Army Game Hi-Res(physics), and Enemy Engaged (physics). The purpose of the television version is to give you an idea of the highest level of realism to use as a metric in addition to your own knowledge of appropriate helicopter physics behavior.

Analysis: You will be asked to complete a short survey that will be used to determine your perception of the realism of each flight you observed.

Administration: The entire process should take about 20 minutes, including the consent forms that must be completed prior to participation in the study.

Propaganda: Your input might be used to help shape future releases of the popular action game America's Army!

Thank you and good Luck!

Helicopter Physics Game Realism Survey Questionnaire 1

I. Background Information:

Age: _____

Gender (M/F): _____

For each of the following questions, circle the category that describes you best:

- A. How often do you play helicopter style computer games (Enemy Engaged, Comanche, Apache, etc)?
Never Once or Twice Monthly Weekly Daily
- B. Are you a helicopter pilot? **Yes No**
- C. Have you ever been on a helicopter ride? **Yes No**
- D. Have you ever seen a helicopter fly in person? **Yes No**
- E. Have you ever seen a real helicopter fly on tv/video or at the movies? **Yes No**
- F. Do you have any experience with motion capture or realistic motion for computer graphics?
Yes No If yes, please briefly describe you involvement on the reverse side.

II. Game Survey

Which system did you see first (circle one)?

Vega Army Game Project(Lo Res) Army Game Project (Hi Res)

Rate how realistic you thought each flight was in the categories below. 'Realistic' is subjective, but should rate how you compare what you see in the flight with what you would expect to see in a real helicopter flight. Use the following scale to indicate your answers:

Didn't Notice 0	Totally Unrealistic 1	Mostly Unrealistic 2	Moderately Realistic 3	Very Realistic 4	Totally Realistic 5
-----------------------	-----------------------------	----------------------------	------------------------------	------------------------	---------------------------

	Vega	AGP (Lo_Res)	AGP (Hi_Res)
How was the helicopter's change of orientation (pivoting nose towards direction of travel)?			
How was the helicopter's change of altitude?			
How was the helicopter's banking (changing directions before nose oriented in direction of travel) ?			
How was the helicopter's overall flight?			

Don't Know 0
 Totally Not Met 1
 Mostly Not Met 2
 Moderately Met 3
 Mostly Met 4
 Totally Met 5

	Vega	AGP (Lo_Res)	AGP (Hi_Res)
How did the helicopter flight rate compared to your expectations for a video game?			

Helicopter Physics Game Realism Survey Questionnaire 2

I. Background Information:

Age: _____

Gender (M/F): _____

For each of the following questions, circle the category that describes you best:

A. How often do you play helicopter style computer games (Enemy Engaged, Comanche, Apache, etc)?
Never Once or Twice Monthly Weekly Daily

B. Are you a helicopter pilot? **Yes No**

C. Have you ever been on a helicopter ride? **Yes No**

D. Have you ever seen a helicopter fly in person? **Yes No**

E. Have you ever seen a real helicopter fly on tv/video or at the movies? **Yes No**

F. Do you have any experience with motion capture or realistic motion for computer graphics?
Yes No If yes, please briefly describe your involvement on the reverse side.

II. Game Survey

Which system did you see first (circle one)?

Enemy Engaged Army Game Project (Hi Res)

Rate how realistic you thought each flight was in the categories below. 'Realistic' is subjective, but should rate how you compare what you see in the flight with what you would expect to see in a real helicopter flight. Use the following scale to indicate your answers:

Didn't	Totally	Mostly	Moderately	Very	Totally
Notice	Unrealistic	Unrealistic	Realistic	Realistic	Realistic
0	1	2	3	4	5

	Enemy Engaged	AGP (Hi_Res)
How was the helicopter's change of orientation (pivoting nose towards direction of travel)?		
How was the helicopter's change of altitude?		
How was the helicopter's banking (changing directions before nose oriented in direction of travel) ?		
How was the helicopter's overall flight?		

Don't Know 0 Totally Not Met 1 Mostly Not Met 2 Moderately Met 3 Mostly Met 4 Totally Met 5

	Enemy Engaged	AGP (Hi_Res)
How did the helicopter flight rate compared to your expectations for a video game?		

Participant Number	1	2	3	4	5
Demographics					
Age	39	31	36	33	31
Gender	M	M	M	M	M
Helicopter Gaming	Once	Never	Never	Never	Once
Pilot	No	No	No	No	No
Ridden on Helicopter	Yes	Yes	Yes	Yes	Yes
Seen a Helicopter Fly (In Person)	Yes	Yes	Yes	Yes	Yes
Seen a Helicopter Fly (TV/Video)	Yes	Yes	Yes	Yes	Yes
Motion Capture/Graphics Experience	Yes	No	Yes	No	Yes
Vega					
Orientation Transitions	2	2	3	1	3
Altitude Transitions	3	3	4	2	4
Banking	2	1	2	1	3
Overall Realism	2	2	3	1	3
Met Expectations for Video Game	3	2	4	1	3
AGP Hi Res					
Orientation transitions	4	3	3	3	3
Altitude Transitions	3	4	3	4	4
Banking	4	3	3	3	4
Overall Realism	4	3	4	3	4
Met Expectations for Video Game	4	3	4	2	4
AGP Lo Res					
Orientation transitions	3	2	3	2	3
Altitude Transitions	3	4	3	4	4
Banking	3	2	3	2	3
Overall Realism	3	2	3	2	4
Met Expectations for Video Game	3	3	4	3	4

Table 19. Realism Survey Results Experiment 1, (1 of 4)

<u>Participant Number</u>	6	7	8	9	10
Demographics					
Age	21	36	36	29	27
Gender	M	M	M	M	M
Helicopter Gaming	Never	Never	Once	Once	Once
Pilot	No	Yes	No	No	No
Ridden on Helicopter	No	Yes	Yes	Yes	Yes
Seen a Helicopter Fly (In Person)	Yes	Yes	Yes	Yes	Yes
Seen a Helicopter Fly (TV/Video)	Yes	Yes	Yes	Yes	Yes
Motion Capture/Graphics Experience	No	No	Yes	No	No
Vega					
Orientation Transitions	2	1	3	1	3
Altitude Transitions	3	1	3	2	4
Banking	2	1	3	1	4
Overall Realism	2	2	3	1	4
Met Expectations for Video Game	3	1	3	1	4
AGP Hi Res					
Orientation transitions	4	1	3	3	5
Altitude Transitions	4	2	4	4	4
Banking	4	1	3	0	5
Overall Realism	4	2	4	3	4
Met Expectations for Video Game	4	3	3	5	5
AGP Lo Res					
Orientation transitions	4	1	3	3	3
Altitude Transitions	2	2	4	4	4
Banking	4	1	3	2	4
Overall Realism	3	2	4	3	4
Met Expectations for Video Game	3	2	3	5	4

Table 20. Realism Survey Results Experiment 1, (2 of 4)

<u>Participant Number</u>	11	12	13	14	15
<u>Demographics</u>					
Age	30	31	31	37	27
Gender	M	M	M	M	M
Helicopter Gaming	Never	Never	Never	Once	Never
Pilot	No	No	No	Yes	No
Ridden on Helicopter	Yes	Yes	Yes	Yes	Yes
Seen a Helicopter Fly (In Person)	Yes	Yes	Yes	Yes	Yes
Seen a Helicopter Fly (TV/Video)	Yes	Yes	Yes	Yes	Yes
Motion Capture/Graphics Experience	No	No	No	Yes	Yes
<u>Vega</u>					
Orientation Transitions	3	2	3	1	1
Altitude Transitions	2	3	3	1	2
Banking	3	2	3	2	1
Overall Realism	3	2	3	1	2
Met Expectations for Video Game	4	2	3	1	1
<u>AGP Hi_Res</u>					
Orientation transitions	3	3	4	2	5
Altitude Transitions	3	2	4	1	4
Banking	3	2	4	1	5
Overall Realism	3	2	4	1	5
Met Expectations for Video Game	4	2	4	2	5
<u>AGP Lo_Res</u>					
Orientation transitions	3	1	1	2	4
Altitude Transitions	3	1	2	1	4
Banking	3	1	1	1	3
Overall Realism	3	1	2	1	5
Met Expectations for Video Game	4	1	2	1	4

Table 21. Realism Survey Results Experiment 1, (3 of 4)

Participant Number	16	17	18	19
Demographics				
Age	58	37	53	19
Gender	F	M	M	M
Helicopter Gaming	Never	Never	Never	Monthly
Pilot	No	No	No	No
Ridden on Helicopter	Yes	Yes	No	No
Seen a Helicopter Fly (In Person)	Yes	Yes	Yes	Yes
Seen a Helicopter Fly (TV/Video)	Yes	Yes	Yes	Yes
Motion Capture/Graphics Experience	No	No	Yes	Yes
Vega				
Orientation Transitions	4	2	3	3
Altitude Transitions	3	0	3	4
Banking	0	2	2	3
Overall Realism	4	2	3	3
Met Expectations for Video Game	3	2	3	3
AGP Hi Res				
Orientation transitions	5	4	4	3
Altitude Transitions	4	0	3	4
Banking	0	3	3	3
Overall Realism	5	3	4	3
Met Expectations for Video Game	4	3	4	3
AGP Lo Res				
Orientation transitions	3	1	4	2
Altitude Transitions	3	1	4	3
Banking	0	2	4	2
Overall Realism	3	1	4	2
Met Expectations for Video Game	4	1	4	2

Table 22. Realism Survey Results Experiment 1, (4 of 4)

<u>Participant Number</u>	1	2	3	4	5	6	7
<u>Demographics</u>							
Age	38	45	36	25	41	34	36
Gender	M	F	M	F	M	M	M
Helicopter Gaming	Never	Never	Once	Never	Once	Once	Once
Pilot	No	No	No	No	Yes*	No	No*
Ridden on Helicopter	No	No	Yes	No	Yes	Yes	No
Seen a Helicopter Fly (In Person)	Yes	Yes	Yes	Yes	Yes	Yes	Yes
Seen a Helicopter Fly (TV/Video)	Yes	Yes	Yes	Yes	Yes	Yes	Yes
Motion Capture/Graphics Experience	No	No	No	No	Yes	No	No
<u>AGP Hi Res</u>							
Orientation Transitions	4	3	3	3	4	4	5
Altitude Transitions	4	2	4	0	4	4	4
Banking	3	3	2	0	4	3	4
Overall Realism	4	3	3	4	4	4	4
Met Expectations for Video Game	0	3	4	5	5	5	5
<u>Enemy Engaged</u>							
Orientation Transitions	3	4	3	4	2	3	3
Altitude Transitions	3	4	4	0	4	3	4
Banking	4	5	3	0	3	2	3
Overall Realism	3	5	3	4	3	3	3
Met Expectations for Video Game	0	4	3	5	1	4	3

Table 23. Realism Survey Results Experiment 2

THIS PAGE INTENTIONALLY LEFT BLANK

LIST OF REFERENCES

- Boeing Company, *Rotorcraft*, (2002).
<http://boeing.com/rotorcraft/military/rah66/flash.html>,
- Bourg, David M., *Physics for Game Developers*, O'Reill and Associates Inc., Sebastopol, California, 2002.
- Brain, Marshall, *How Stuff Works*, (2000).
<http://www.howstuffworks.com/helicopter.htm>.
- Crouch, T., The RAH-66 Comanche: Key to the Army Vision., *Army Aviation*, March/April, pp. 18-24, Westport, CT: Army Aviation Publications, Inc., 2000.
- Fay, John, *The Helicopter*, David & Charles Inc. North Pomfret, Vermont, 1978.
- Headquarters, Department of the Army, *Aircrew Training Manual Attack Helicopter, AH-64* (Training Circular 1-214), Washington, DC: U.S. Government Printing Office, 1992.
- Headquarters, Department of the Army, *Attack Helicopter Operations* (Field Manual 1-112), Washington, DC: U.S. Government Printing Office, 1997.
- Headquarters, Department of the Army, *Utility and Cargo Helicopter Operations* (Field Manual 1-113), Washington, DC: U.S. Government Printing Office, 1997.
- Headquarters, Department of the Army, *Tactics, Techniques and Procedures for the Regimental Aviation Squadron* (Field Manual 1-114), Washington, DC: U.S. Government Printing Office, 2000.
- Headquarters, Department of the Army, *Fundamentals of Rotor and Power Train Maintenance-Techniques and Procedures* (Field Manual 1-514), Washington, DC: U.S. Government Printing Office, 1991.
- Headquarters, Department of the Army, *Cavalry Operations* (Field Manual 17-95), Washington, DC: U.S. Government Printing Office, 1996.
- Headquarters, Department of the Army, *Cavalry Troop* (Field Manual 17-97), Washington, DC: U.S. Government Printing Office, 1995.
- Headquarters, Department of the Army, *Operational Requirements Document for the RAH-66 Comanche Armed Reconnaissance/Attack Helicopter* (ORD), Washington, DC: U.S. Government Printing Office, 1999.

Leishman, Gordon J., *Principles of Helicopter Aerodynamics*, Cambridge University Press, New York, New York, 2000.

Office of the Chief of Naval Operations, *Helicopter Training Manual*, (NAVAER 00-80T-41), Washington, DC: U.S. Government Printing Office, 1952.

Padfield, Gareth D., *Helicopter Flight Dynamics: The Theory and Application of Flying Qualities and Simulation Modeling*, AIAA Inc. Washington, DC, 1996.

Prouty, Raymond W., *Helicopter Performance, Stability, and Control*, PWS Publishers, Boston, Massachusetts, 1986.

Saunders, George H., *Dynamics of Helicopter Flight*, John Wiley & Sons, Inc., New York, New York, 1975.

Sikorsky, *Products*, (2002),
http://www.sikorsky.com/details/0,3036,CL11_DIV69_ETI254,00.html.

Zyda, Michael J., Macedonia, Michael R., Brutzman, Donald P., Pratt, David R., Barham, Paul T., "NPSNET: A Multi-Player 3D Virtual Environment Over the Internet", *Proceedings of 1995 Symposium on Interactive 3D Graphics*, 1995.

INITIAL DISTRIBUTION LIST

1. Defense Technical Information Center
Ft. Belvoir, VA
2. Dudley Knox Library
Naval Postgraduate School
Monterey, CA
3. Professor Michael Zyda
Code MOVES
Naval Postgraduate School
Monterey, CA
4. Research Assistant Professor Michael Capps
Code CS/Cm
Naval Postgraduate School
Monterey, CA
5. MAJ Keith M. Perkins, USA
Chief, Simulations Center
University of Information Technology
Fort Gordon, GA