





Class PN1993

Book . M6

Scanned from the collections of The Library of Congress



Packard Campus
for Audio Visual Conservation
www.loc.gov/avconservation

Motion Picture and Television Reading Room
www.loc.gov/rr/mopic

Recorded Sound Reference Center
www.loc.gov/rr/record





OCTOBER 10, 1914

Motion Picture News

HAS THE QUALITY CIRCULATION OF THE TRADE

357
620
10

DANIEL FROHMAN
Presents

The dainty,
magnetic star,

MARGUERITE
CLARK

In a bewitching characterization,
“WILDFLOWER”
By Mary Germaine.

In Four Parts Released October 15th

FAMOUS PLAYERS FILM COMPANY
213-229 W 26th ST. ADOLPH ZUKOR President, NEW YORK
DANIEL FROHMAN, Man Dir. EDWIN S. PORTER, Tech. Dir.

PN 1093
M/G



THE TREY O' HEARTS

BY LOUIS JOSEPH VANCE

THE MASTER PROBLEM PLAY
IN FIFTEEN STORIES

FEATURING
CLEO MADISON & GEO LARKIN
PRODUCED BY WILFRED LUCAS





PROSPERITY

THE ONLY WAY TO SUCCESS IS BY THE SATISFACTION RATE AND BY INSTALLING THE PERFECT MOTION PICTURE PROJECTING APPARATUS, POWER'S CAMRAGRAPH No. 6A, IN YOUR THEATRE, YOU SATISFY THE PUBLIC AND RETAIN THEIR PATRONAGE, WHICH IS ABSOLUTELY ESSENTIAL TO YOUR PROSPERITY

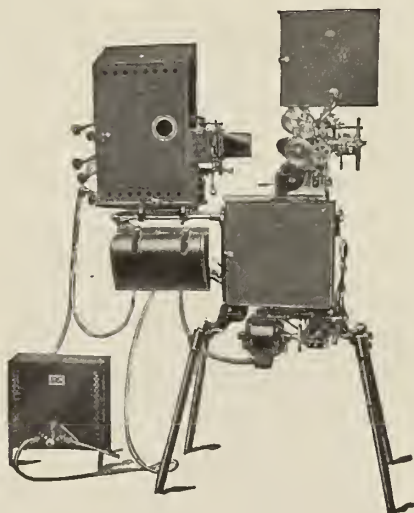

NICHOLAS POWER COMPANY
 NINETY GOLD STREET NEW YORK CITY

THE KING OF THE AIR

A drama played in two elements and reels. An aeroplane falls from the sky with its aviator and is wrecked on the ground. This is as thrilling a scene as has ever been shown in motion pictures. It's an ill fall, however, that does nobody good and the aviator falls into luck more to be prized than the \$40,000 prize he loses. 1-6 sheet posters.

The Count That Took the Count

1-part Robbins-made American comedy. There may be an Irish count—papa thought there was, but neither he nor the real count counted with daughter. The son, however, counts with you and with every funny-bone in your audience.

THE PERILS OF PAULINE

Inside your theatre or out Pauline is the favorite. She's the first lady of the screen. Pauline inside your theatre reaches to the crowds outside and draws them in. Once in to see Pauline they'll come again.

PAULINE PLAYS TO CAPACITY HOUSES



THE TICKET-LEAVE MAN

3-part Pathe-American-made drama. A man's trust in his friend forces him to atone for the crimes for which the friend himself is guilty. In the face of forgery and bribery the wrong man is compelled to bide

his time in a Tropical Convict colony, and from a scuttled ship becomes a castaway in company with the right man's fiancée. Chock full of adventures, escapes, and the most tense situations. Featuring Eleanor Woodruff. 1-3-6 sheet posters.

ECLECTIC FEATURE FILM EXCHANGES FOR YOUR USE

- | | | | | |
|------------------------------------|-------------------------------|--------------------------------------|-------------------------------------|--------------------------------|
| ATLANTA
61 Walton St. | DALLAS
Andrews Bldg. | MINNEAPOLIS
4th and Hennepin Sts. | PHILADELPHIA
1235 Vine St. | SAN FRANCISCO
67 Turk St. |
| BOSTON
3 Tremont Row | DENVER
Nassau Bldg. | NEW ORLEANS
910 Gravier St. | PITTSBURGH
715 Liberty Ave. | SEATTLE
810 Third Ave. |
| CHICAGO
5 So. Wabash Ave. | KANSAS CITY
928 Main St. | NEW YORK
115 E. 23rd St. | PORTLAND
392 Burnside Ave. | ST. LOUIS
3210 Locust St. |
| CINCINNATI
217 E. 5th St. | LOS ANGELES
114 E. 7th St. | OMAHA
1312 Farnam St. | SALT LAKE CITY
68 South Main St. | SYRACUSE
214 E. Fayette St. |
| CLEVELAND, 622 Prospect Av., S. E. | | | WASHINGTON, 7th & E Sts., N. W. | |

THE ECLECTIC

110 West 40th Street



FILM COMPANY

New York City

"The Cream of American and European Studios"

MR. MAX FIGMAN IN "THE HOOSIER SCHOOLMASTER"

By EDWARD EGGLESTON
(5 REELS)



ARRANGED AND PRODUCED
BY

M. DE LA PARELLE

ASSISTED BY

ELLIOT J. CLAWSON

WILL SELL TO FIRST
CLASS HOUSES ON A
COMMISSION BASIS OR
TO REPUTABLE
STATE RIGHT
BUYERS



TO BE
RELEASED SOON

MASTERPIECE FILM MFG. CO.

1111 VAN NUYS BLDG.

LOS ANGELES.

GENERAL

MAIN OFFICE: 200 F

LIST

<i>CITY</i>	<i>STATE</i>	<i>STREET ADDRESS</i>
ALBANY	NEW YORK	737 BROADWAY
ATLANTA	GEORGIA	RHODES BUILDING
BALTIMORE	MARYLAND	36 SOUTH EUTAW STREET
BANGOR	MAINE	123 FRANKLIN STREET
BOSTON	MASSACHUSETTS	218 COMMERCIAL STREET
BUFFALO	NEW YORK	122 PEARL STREET
BUTTE	MONTANA	50 E. BROADWAY
CALGARY	ALTA, CANADA ..	85 McDOUGALL BLOCK
CHICAGO	ILLINOIS	429 S. WABASH AVENUE
CHICAGO	ILLINOIS	139 N. CLARK STREET
CHICAGO	ILLINOIS	19 S. WABASH AVENUE
CINCINNATI	OHIO	514-516 ELM STREET
CLEVELAND	OHIO	1022 SUPERIOR AVENUE, N. E.
COLUMBUS	OHIO	26 W. NAGHTEN STREET
DALLAS	TEXAS	2017 COMMERCE STREET
DENVER	COLORADO	1448 CHAMPA STREET
DETROIT	MICHIGAN	71 GRISWOLD STREET
HARRISBURG	PENNSYLVANIA ..	322 CHESTNUT STREET
INDIANAPOLIS	INDIANA	24 W. WASHINGTON STREET
KANSAS CITY	MISSOURI	921 WALNUT STREET
LOS ANGELES	CALIFORNIA	822 SO. BROADWAY
MEMPHIS	TENNESSEE	302 MULBERRY STREET
MILWAUKEE	WISCONSIN	220 W. WATER STREET
MINNEAPOLIS	MINNESOTA	909 HENNEPIN AVENUE
MONTREAL	CANADA	243 BLEURY STREET

FILM CO.

AVENUE, NEW YORK

BRANCHES

<i>CITY</i>	<i>STATE</i>	<i>STREET ADDRESS</i>
NEW HAVEN.....	CONNECTICUT	215 MEADOW STREET
NEW ORLEANS	LOUISIANA	840 UNION STREET
NEW YORK CITY ...	NEW YORK	440 FOURTH AVENUE
NEW YORK CITY ...	NEW YORK	71 W. 23RD STREET
NEW YORK CITY ...	NEW YORK	260 WEST 42ND STREET
OKLAHOMA CITY ..	OKLAHOMA	211 WEST 2ND STREET
OMAHA	NEBRASKA	208 SOUTH 13TH STREET
PHILADELPHIA	PENNSYLVANIA	1308 VINE STREET
PITTSBURGH	PENNSYLVANIA	119 FOURTH AVENUE
PITTSBURGH	PENNSYLVANIA	436 FOURTH AVENUE
PORTLAND	OREGON	393-5 OAK STREET
ROCHESTER	NEW YORK	501 CENTRAL BUILDING
ST. JOHN	N. B., CANADA	122 GERMAIN STREET
ST. LOUIS	MISSOURI	3610 OLIVE STREET
SALT LAKE CITY ...	UTAH	260 FLORAL AVENUE
SAN FRANCISCO	CALIFORNIA	138 EDDY STREET
SEATTLE	WASHINGTON	819 THIRD AVENUE
SPOKANE	WASHINGTON	120 WALL STREET
SYRACUSE	NEW YORK	HIPPODROME BUILDING
TORONTO	CANADA	172 KING STREET, WEST
VANCOUVER	B. C., CANADA	440 PENDER STREET, WEST
WASHINGTON	D. C.	7TH & E STREETS, N. W.
WHEELING	WEST VIRGINIA	1141 EAST SIDE CHAPLINE STREET
WILKES-BARRE	PENNSYLVANIA	47 S. PENNSYLVANIA AVENUE
WINNIPEG	MAN., CANADA	220 PHOENIX BLOCK

KAY-BEE

K
E
Y
S
T
O
N
E

B
R
O
N
C
H
O

KAY-BEE

One Two-Part Photoplay a Week

Friday, Oct. 9—The Sheriff of Muscatine
" " 16—The Word of His People
" " 23—The Spark Eternal

KEYSTONE

Three a Week

Monday, Oct. 5—Their Ups and Downs
Thursday, " 8—Hello Mabel
Saturday, " 10—Those Love Pangs
Monday, " 12—The Anglers

The Keystone Co. in the very near future will release a multiple reel comedy every other week in addition to the regular releases.

BRONCHO

One Two-Part Photoplay a Week

Wednesday, Oct. 7—The Boss of the 8th
" " 14—The End of the Galley
" " 21—Shorty and Sherlock Holmes

DOMINO

One Two-Part Photoplay a Week

Thursday, Oct. 8—The Whiskey Runners
" " 15—Jimmy
" " 22—The Power of the Angelus
" " 29—Eric the Red's Wooing

Released Exclusively Through the Mutual Film Corporation

PENNANTS—Beautiful bright colored pennants of the four brands can be had by sending to the PUBLICITY DEPT., 35 cents for one, \$1.25 for set of four.

PHOTOS—8 x 10 photos of our players can be had by sending to the PUBLICITY DEPT. 15 cents for one, 50 cents for set of four, \$1.00 for set of eight.

Keystone Mabel in Four Poses 50 Cents

New York Motion Picture Corporation

FORTY-SECOND STREET and BROADWAY, Longacre Building, NEW YORK

DOMINO

NOW'S THE TIME

to book the greatest spectacle and most gripping photoplay ever made in America

"THE WRATH OF THE GODS"

or The Destruction of Sakura-Jima

6 PARTS

PRODUCED BY
Thomas H. Ince

FEATURING THE
Imperial Japanese Company

IF FOR ANY REASON BOOKINGS CANNOT BE SECURED AT ANY OF THE FOLLOWING EXCHANGES, WRITE OR WIRE US INSTANTLY.

- | | |
|--|---|
| PACIFIC MUTUAL FILM CORP.,
1929 Second Avenue, Seattle, Wash. | MUTUAL FILM CORP.,
423 Ninth Street, Washington, D. C. |
| PACIFIC MUTUAL FILM CORP.,
164 Turk Street, San Francisco, Calif. | MUTUAL FILM CORP.,
71 West 23rd Street, New York City |
| COLORADO FEATURE FILM CO.,
21 Iron Bldg., Denver, Colo. | WESTERN FILM EXCHANGE,
145 West 45th Street, New York City |
| MUTUAL FILM CORP.,
1413 Harney Street, Omaha, Neb. | MUTUAL FILM CORP.,
154 St. Catherine St., W., Montreal, Canada |
| MUTUAL FILM CORP.,
1807 Main Street, Dallas, Texas | MUTUAL FILM EXCHANGE,
28 W. Lexington St., Baltimore, Md. |
| MUTUAL FILM CORP. OF MISSOURI,
9th & Pine Streets, St. Louis, Mo. | MUTUAL FILM CORP.,
272 Washington St., Buffalo, N. Y. |
| CONTINENTAL FEATURE FILM CO.,
340 Carondelet Street, New Orleans, La. | MUTUAL FILM CO.,
17 Opera Place, Cincinnati, Ohio |
| PACIFIC MUTUAL FILM CORP.,
40½ Luckie Street, Atlanta, Ga. | MUTUAL FILM CO.,
Willoughby Bldg., Indianapolis, Ind. |
| CONTINENTAL FEATURE FILM CO.,
5 South Wabash Ave., Chicago, Ill. | MUTUAL FILM CO.,
Empress Theatre Bldg., Kansas City, Mo. |
| CONTINENTAL FEATURE FILM CO.,
307 Enterprise Bldg., Milwaukee, Wis. | PACIFIC MUTUAL FILM CORP.,
738 South Olive Street, Los Angeles, Cal. |
| CONTINENTAL FEATURE FILM CO.,
106 Prospect Avenue, Cleveland, Ohio | MUTUAL FILM CORP.,
440 Temple Court, Minneapolis, Minn. |
| CONTINENTAL FEATURE FILM CO.,
420 Penn Avenue, Pittsburgh, Pa. | MUTUAL FILM CORP.,
25 Hudson Street, Oklahoma, Okla. |
| CONTINENTAL FEATURE FILM CO.,
902 Filbert Street, Philadelphia, Pa. | MUTUAL FILM CORP.,
14 McTyre Bldg., Salt Lake City, Utah |
| CONTINENTAL FEATURE FILM CO.,
1106 Boylston Street, Boston, Mass. | |

OR BY WRITING OR TELEGRAPHING US AT OUR EXPENSE

NEW YORK MOTION PICTURE CORP.

Longacre Building

42nd STREET, BROADWAY

NEW YORK



THE SUPERB

All Star
Feature Corporation

California Motion
Picture Corp.

The world's most artistic productions
with a view to our

Beginning with

The Stage's Most Successful and Important Star

MISS ETHEL BARRYMORE

in

"THE NIGHTINGALE"

A Brilliantly Vivid and a Vividly Brilliant Dramatic
Masterpiece in Five Parts by

AUGUSTUS THOMAS

RELEASED OCTOBER 5

SECOND RELEASE

ANDREW MACK in

LIST OF OFFICES

Maine, New Hampshire, Vermont, Rhode
Island, Massachusetts, Connecticut:

ALCO FILM CORP. OF NEW ENGLAND
162 Tremont Street
BOSTON, MASS.

Delaware, Maryland, District
of Columbia, Virginia:

ALCO FILM SERVICE
327 St. Paul Street
BALTIMORE, MD.

Wisconsin, Minnesota, North and South Dakota: Western Pennsylvania, Ohio, Kentucky, West Virginia: New Jersey and Eastern Pennsylvania:

ALCO FILM SERVICE
Temple Court Bldg.
MINNEAPOLIS, MINN.

ALCO FILM SERVICE
212 Fourth Avenue
PITTSBURGH, PA.

ALCO FILM SERVICE, INC.
1331 Vine Street
PHILADELPHIA, PA.

If ALCO PICTURES can be improved, ATSCO
Other pictures need IT. Thousands of theatres improved their program

ALCO FILM

ALCO BUILDING, 218 WEST



PRODUCTS OF

Popular Plays & Players
Company

B. A. Rolfe Photo
Play Company

distributed on the most equitable basis
exhibitors supremacy

Our Policy

- TO PRODUCE THE BEST
- TO SPARE NO PAINS TO AID THE EXHIBITOR
- TO LIVE AND LET LIVE
- TO ACHIEVE THE HEIGHTS OF ARTISTRY TO WHICH NO OTHER MAN ASPIRES
- TO OFFER A NEEDY MARKET, A STIMULATING GRADE OF PLAYS THAT WILL SET A NEW STANDARD

OCTOBER 12

"THE RAGGED EARL"

NOW OPEN FOR —

Illinois and Indiana:	State of New York:	California, Nevada, Arizona:
ALCO FILM SERVICE 512 Mallers Bldg. 5 So. Wabash Avenue CHICAGO, ILL.	NEW YORK ALCO FILM EXC. 218 West 42nd Street NEW YORK CITY, N. Y.	ALCO FILM SERVICE (Sol Lesser) 234 Eddy Street SAN FRANCISCO, CAL.

Missouri, Kansas, Iowa, Nebraska:	Washington, Idaho, Montana, Oregon:
ALCO FILM SERVICE OF MISSOURI New Grand Central Theatre Grand and Lucas Aves., ST. LOUIS, MO.	ALCO FILM SERVICE 27 West Park Street BUTTE, MONT. ALCO FILM SERVICE 1214 Third Avenue SEATTLE, WASH. ALCO FILM SERVICE 710 Northwestern Bank Bldg. PORTLAND, ORE. ALCO FILM SERVICE 911 Trent Avenue SPOKANE, WASH.

"ORIGINAL" GOLD FIBRE SCREENS will do it.
by the "ALCO" way, now let ATSCO improve your projection.

CORPORATION

12ND STREET, NEW YORK CITY



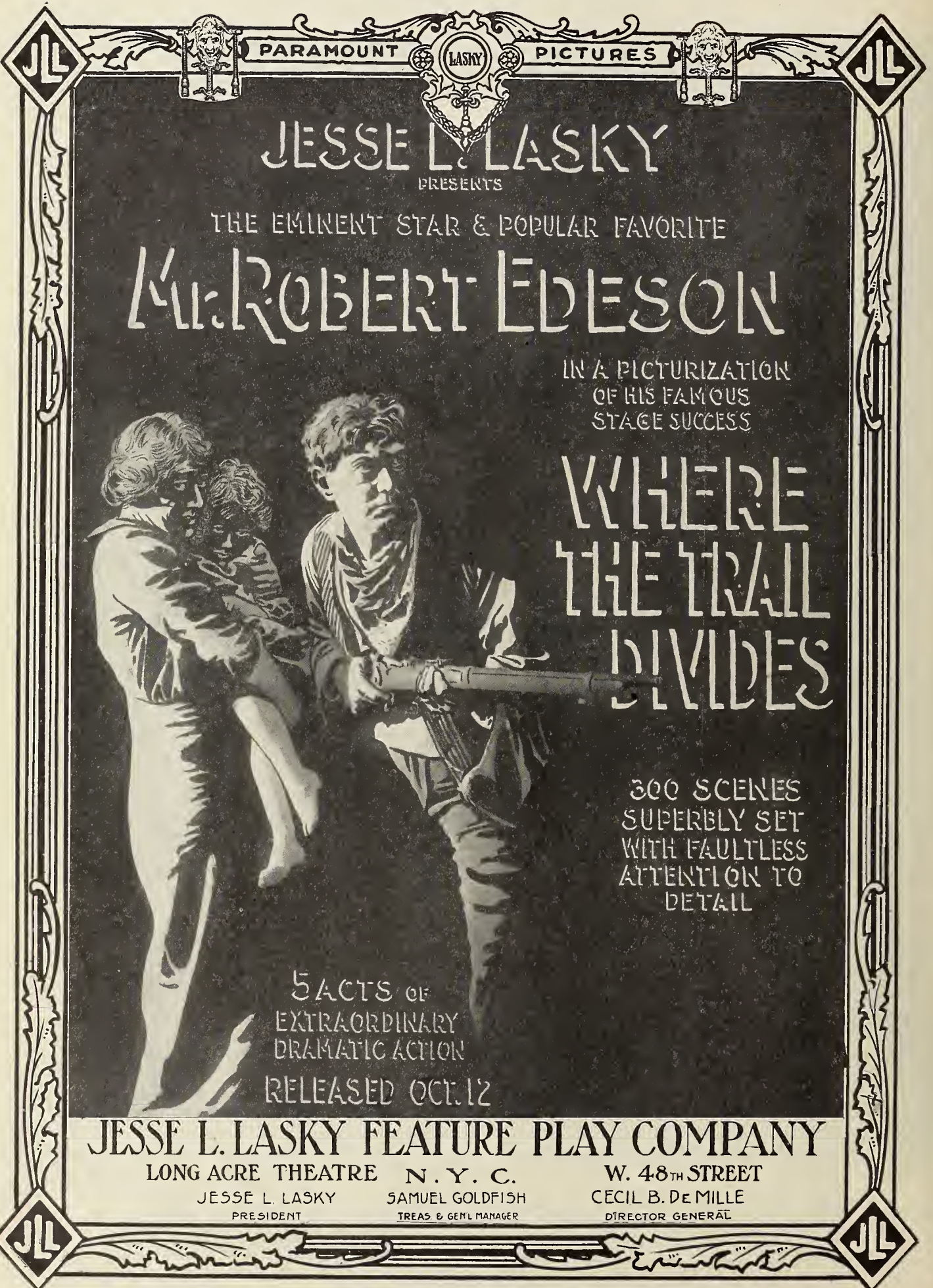

PARAMOUNT LASKY PICTURES

JESSE L. LASKY

PRESENTS

THE EMINENT STAR & POPULAR FAVORITE

MR. ROBERT EDESON

IN A PICTURIZATION
OF HIS FAMOUS
STAGE SUCCESS

WHERE
THE TRAIL
DIVIDES



300 SCENES
SUPERBLY SET
WITH FAULTLESS
ATTENTION TO
DETAIL

5 ACTS OF
EXTRAORDINARY
DRAMATIC ACTION

RELEASED OCT. 12

JESSE L. LASKY FEATURE PLAY COMPANY

LONG ACRE THEATRE	N. Y. C.	W. 48TH STREET
JESSE L. LASKY	SAMUEL GOLDFISH	CECIL B. DE MILLE
PRESIDENT	TREAS. & GENL. MANAGER	DIRECTOR GENERAL

Cosmofotofilm Co

"Where the real features come from"

THE LONDON FILM COMPANY'S Great Naval Drama

"ENGLAND'S MENACE"

The Greatest Money-Maker of the Season

Exhibitors! Attention!



London Film Co.
(Trade Mark)



London Film Co.
(Trade Mark)

For Bookings, address:

NEW ENGLAND—American Feature Film Co., 162 Tremont St., Boston, Mass.
 GREATER NEW YORK & NORTHERN NEW JERSEY—Greene's Feature Photoplays, World's Tower Bldg.,
 New York.
 EASTERN PA., SOUTHERN N. J., DELAWARE, MARYLAND & D. C.—Tri-State Star Feature Co., 119 S. 4th
 St., Philadelphia, Pa.
 WESTERN PA., WEST VA.—Liberty Film Renting Co., 105 4th Ave., Pittsburgh, Pa.
 OHIO, INDIANA & KENTUCKY—Empress Feature Film Co., Merchants' Bank Bldg., Indianapolis, Ind.
 MICHIGAN—Progressive Film and Equipment Co., 97 Woodward Ave., Detroit, Mich.
 ILLINOIS & S. WISCONSIN—General Feature Film Co., 5 S. Wabash Ave., Chicago, Ill.
 MINNESOTA, N. WISCONSIN, IOWA, N. & S. DAKOTA—Famous Players Star Feature Film Service, Temple
 Court Bldg., Minneapolis, Minn.
 OREGON, WASHINGTON, IDAHO—Film Supply Co., 385½ Alder St., Portland, Ore.
 DOMINION OF CANADA—All Features, Ltd., 56 King St., W., Toronto, Ont.

For information regarding Territory not included above and our next release

"ENGLAND EXPECTS ———"

(Based on Nelson's famous signal at the battle of Trafalgar)

"England expects that every man this day will do his duty"

Address

Cosmofotofilm Co

WORLD'S TOWER BUILDING, 110-112 W. 40TH STREET, NEW YORK

Be sure to mention "THE MOTION PICTURE NEWS" when writing to advertisers.



EDISON



ON THE ISLE OF SARNE

A Comedy-Drama adapted from "The Picaroon" by H. B. Mariott Watson

Countess Dorothea was plunged into the depths of despair on learning that her uncle, the Duke, was determined upon her acceptance of Count Sigimund. She and her tutor were taken to the Isle of Sarne until she should submit. One day a yacht approached supposed to have on board the dreaded Sigimund; but instead it brought a stranger, Peter Seabrooke, with whom the Countess eventually fell in love and with whom she fled to England. Meanwhile, however, Seabrooke impersonated Sigimund so well that the Duke never suspected he was anyone else until the very last. An exciting, well planned film.

In two parts. 2,000 ft. To be released Friday, Oct. 16th

COMING EDISON RELEASES

Mon.	Oct. 12—	BUSTER BROWN'S EDUCATION	500 ft.	Comedy
		GEORGE WASHINGTON JONES	500 "	Comedy
Tues.	" 13—	THE LETTER THAT NEVER CAME OUT	1,000 "	Comedy
Wed.	" 14—	ANDY AND THE REDSKINS	1,000 "	Drama
Fri.	" 16—	ON THE ISLE OF SARNE	2,000 "	Comedy-Drama
Sat.	" 17—	THE CASE OF THE VANISHED BONDS	1,000 "	Drama

TWO GREAT EDISON SUCCESSES

"THE LONG WAY," a three-part reel just released. A masterpiece of dramatic production. Scenic and photographic effects are very beautiful.

"MY FRIEND FROM INDIA," another masterpiece in which Walter E. Perkins is in the title role. To be obtained through the General Film Company's special releases. Full of laughs.

Order Edison Posters of the Morgan Lithograph Co., Cleveland, Ohio, direct



TRADE MARK
Thomas A Edison
Makers of the Edison Kinetoscope,
Model "D"

THOMAS A. EDISON, Inc.
275 Lakeside Avenue, Orange, N. J.



"In the past I have agreed with Thomas Carlyle that silence and action seem contraries, but are often seen in operation. But in this instance I can hardly restrain myself from telling the motion picture world about our capturing 'THE SEATS OF THE MIGHTY.' I consider this picture the great American Masterpiece."

LEWIS J. SELZNICK.

TWO MIGHTY FORCES JOINED

THE WORLD FILM CORPORATION

HAS THE HONOR OF ANNOUNCING THAT IT
HAS ARRANGED WITH THE

COLONIAL MOTION PICTURE CORPORATION

FOR THE PRODUCTION OF
SIR GILBERT PARKER'S FAMOUS NOVEL

"The Seats of the Mighty"

(CONTAINING 9,000 FEET OF THRILLS)

the greatest screen production ever undertaken in America, the result of unlimited capital and the best trained talent under the direction of T. Hayes Hunter, by a superb company of Broadway stars, WITH LIONEL BARRYMORE, supported by Millicent Evans, Lois Meredith, Thomas Jefferson, Glen White, Clinton Preston, Harold Hartsell, Garce Leigh and Marjorie Bonner. "The Seats of the Mighty" is the most ambitious photo-play ever produced in America and it will be

A SPECIAL RELEASE OF

WORLD FILM CORPORATION

LEWIS J. SELZNICK
Vice-President and
General Manager

130 West 46th Street, New York City

23 Branch Offices throughout the United States and Canada



Drawn Into the Quicksand

In episode No. 16 of *The Million Dollar Mystery* is a thrilling portrayal of an *actual quicksand* into which Flo La Badie falls. See this exciting scene. See this struggle between life and death. See the daring rescue by James Cruze.

This sensational episode indicates the reason for the tremendous popularity of *The Million Dollar Mystery*. Undoubtedly, this is the biggest success ever known in motion picture circles.

THE MILLION DOLLAR MYSTERY

Story by Horold MacGrath Scenario by Lloyd Lonergan

Thanhouser's Million Dollar Motion Picture Production

Episode No. 16 has just been released. A two-reel episode is released each week. The entire story is produced in 23 episodes. Bookings on all episodes are now being made.

Don't overlook this: \$10,000.00 will be paid by the Thanhouser Film Corporation for the best 100-word solution of the mystery. For booking dates address

SYNDICATE FILM CORPORATION

71 West 23rd Street, New York

Room 411, 5 S. Wabash Avenue, Chicago

or Syndicate Film Corporation Representative at any Mutual Exchange in the United States and Canada

THE THANHOUSER THREE-A-WEEK

Tuesday, Oct. 16. "The Cripple." (Two reels.) An exceptional drama featuring Nolan Kane, Lydla Mead, Arthur Bauer, Mrs. Fairbanks, E. C. Ward and Virginia Waite.

Friday, Oct. 9. "The Benevolence of Conductor 786." A one-reel drama illustrating the goodness of charity. The cast includes Riley Chamberlin, Helen Badgley (Thanhouser Kidlet), Marion and Madeline Fairbanks, Fan Bourke, Joe Sparks and J. S. Murray.

Sunday, Oct. 11. "The Rescue." One-reel drama featuring Mildred Hellar, Harry Benham and Mayre Hall.

THANHOUSER FILM CORPORATION, New Rochelle, N. Y.

Head European Office, Thanhouser Films, Ltd., London, W. C., England

Regular Thanhouser releases are distributed exclusively in the United States and Canada by the Mutual Film Corporation.



“When You See It
In ‘The News’
It’s NEWS”

Motion Picture News

“The Exhibitors
Medium of
Communication”

HAS THE QUALITY CIRCULATION OF THE TRADE

Tel. 7650 Bryant

NO. 220 WEST FORTY-SECOND STREET

New Y

Volume X

OCTOBER 10, 1914.

Number

The High Cost of Circulation

THE other day I overheard two men discussing the effect of the war upon the newspaper business.

One thought the newspapers were reaping a harvest because the public was buying so freely.

“On the contrary,” said the other, a publisher, “we are losing heavily. It costs us one and one-eighth cents to put in the street the paper you buy for a penny—this in normal times.

“Take from this the distributor’s profit, and you’ll see that we lose heavily on every unit of circulation.

* * *

“THE more copies we vend the more money we lose—*unless* the advertising revenue increases in proportion. That never happens when the circulation is suddenly jumped by war news. On the contrary, it is more apt to diminish—to go below its amount in normal times.”

The other man was vastly surprised. He didn’t know that it costs more to produce a paper than it sells for.

* * *

IT would seem that the general public—advertisers included—not only knows less about the publishing business than almost any other industry, but has a complete misconception of it.

This is due in large measure to the fact that—for some reason—the publisher is disinclined to take the outsider into his confidence.

That makes little difference so far as the reading public is concerned—except that not one reader realizes what a value he is getting for his money.

* * *

BUT the advertiser should know the basic fact of the publishing business; else how can he buy his space intelligently—as he buys labor, goods and commodities in general?

His general idea of the publisher is that the latter is bent upon acquiring as large a circulation as possible.

That is true—*provided* advertising is acquired at a rate sufficient at least to make up *the inevitable loss* in circulation.

* * *

IT will surprise him to know that there are several metropolitan dailies sold at one cent and at least two national weeklies sold at five cents that are

scared to death of big circulation, for fear the advertiser will not pay *the necessarily increased rate*.

And of the thousands of publications issued in this country, there are only a few isolated and unimportant instances where a publication makes money on circulation alone.

These publications have no advertising promise, whereas every publication of well-known advertisement merit is a *heavy loser in circulation revenue*.

* * *

IN fact, the better a publication, the more heavily it will lose on its price to the reader, provided of course its price is made popular.

“Better” means heavy editorial expense, and high quality and paper of a superior character.

The newspaper form is the cheapest way to get a publication; but even this kind of publication loses on circulation revenue unless its editorial expense is very cheap and its price comparatively very high.

In each case its circulation will be so restricted that it is not to interest the advertiser.

* * *

THE MOTION PICTURE NEWS loses a good-sized fortune each year on circulation revenue.

It costs us many times the subscription price to produce the publication.

But we give the subscriber *big value*, and interest and confidence.

And then we deliver these substantial units of circulation—each one a man generally in business—a *buyer*—to the advertiser, charging him *definitely* any honest commodity is sold.

Naturally, we are not interested in acquiring non-business, non-buying circulation, for the reason that it is a loss to us and no gain to the advertiser.

* * *

THE thing for the advertiser to consider in buying space, is, first, the number of buyers of his product, and then, the fact that he only *saves* what he pays for any circulation *in excess of that number*.

We contend—and *know*—that the statistician’s estimate of 18,000 picture theaters in the United States and Canada is wrong by more than one-third.

WILLIAM A. [unclear]

DUSS EXPOSITION PLANS*Special to THE MOTION PICTURE NEWS*

Dallas, Sept. 28.

That the proposed motion picture exposition to be held in Dallas October 26 and 27 is creating considerable interest was evidenced by the visit to Dallas recently of Carl Laemmle, president of the Universal Film Manufacturing Company, of New York; J. C. ... general manager of the same company, and William Oldknow, of New York, president of the Consolidated Film and Supply Company, of this

While in Dallas these well-known men held a conference with about twenty of the local exhibitors, at which plans for the big exposition were discussed. The discussion of plans for the exposition was held over a dinner which was tendered the visitors by the exhibitors.

Exhibitors from Texas, Arkansas, Oklahoma and New Mexico are expected to be present in force.

E. R. HAMBRICK.

EXPECT LARGE GATHERING AT FRISCO*Special to THE MOTION PICTURE NEWS*

Los Angeles, Sept. 28.

Practically all the officers, together with a large number of members of the local exhibitors' League, are planning to attend the annual convention of the Exhibitors' State League, to be held at San Francisco, Tuesday, Wednesday and Thursday, October 6, 7 and 8.

The local organization until a few days ago was considered an outlaw of the Exhibitors' State League, which has affiliated with organizations at San Diego, Sacramento, and this meeting will be the first in which all motion picture exhibitors' organizations of the state have taken part.

THEATRE REMODELED*Special to THE MOTION PICTURE NEWS*

Joliet, Ill., Sept. 29.

The Lincoln Theatre, the remodeled and improved old Joliet Theatre, has opened for the season. As an opening attraction the management presented the excellent motion picture dramatization of the life of William Tell, the hero of the novel, "The Christian."

The theatre presents a beautiful appearance with its mosaic floors in the lobby and foyer and with its artistically decorated interior. An indirect lighting system is installed.

REISINGER DEAD

Reisinger, carbon importer, art dealer and merchant, at 11 Broadway, died on September 26 at Langenscheidt, near Wiesbaden, Germany, and was born January 29, 1856.

He has two sons, Curt H. Reisinger, 100 West 42nd street, and Walter F., a student at Harvard University. The funeral will be held here.

Minnesota Exhibitors Plan Big Convention**Association Officers Expect a Turn-Out of About 350 in Minneapolis During the Three Days' Session, October 27-29***Special to THE MOTION PICTURE NEWS*

Minneapolis, Sept. 29.

THE Motion Picture Exhibitors' Association of Minnesota will hold a convention at the West Hotel, Minneapolis, for three days, commencing October 27.

The first day of the convention has been set aside to enable out-of-town exhibitors to get acquainted with the exchange men. It is the intention of the committee in charge of the entertainment to escort the out-of-town exhibitors to the local exchanges, and have them get an idea of how a film exchange is really run.

It is generally understood that 60 per cent. of the out-of-town exhibitors have never seen the inside of a film exchange.

The officers of the Motion Picture Exhibitors' Association of Minnesota are: Harry H. Green, president; J. Gilowski, vice-president; W. A. Steffes, secretary, and D. G. Rodgers, treasurer.

About 350 of the exhibitors are expected, and this coming convention promises to far surpass anything ever attempted along this line. The whole parlor floor, the entire lobby, gallery, including the assembly hall and adjoining rooms on that floor have been reserved for exhibits.

Film exchanges will display their products. There will also be a projection room in which motion pictures will

be run continuously during the three days.

Mr. Green declares that 85 per cent. of the members of the league are working day and night to make this coming event the biggest one ever achieved anywhere. The convention will close with a banquet and dance.

Mr. Green further states that an open meeting will be held every day, to which all are not only welcome but urged to attend as well.

Any manufacturers or film men of the Northwest desiring to make reservation for accommodations and display rooms are requested to address the secretary for price and space.

The general office of the Motion Picture Exhibitors' Association of Minnesota is located at 240 Temple Court, and Mr. Steffes, the secretary, has expressed himself more than willing to do everything in his power to look out for advance reservations for hotel accommodations, etc.

The general feeling is that this coming convention is bound to be a success, judging from the enthusiasm displayed by all members of the league.

The Minnesota league is one of the few not associated with the national organization, but its membership is increasing week after week, and this convention is bound to boom things along.

FRED. S. MEYER.

Higher Prices Succeed in Wilkes-Barre**Public, Drawn to Renovated Theatre by Extensive Advertising, Makes No Objection to Twenty Cents, Because of Quality of the Pictures***Special to THE MOTION PICTURE NEWS*

Wilkes-Barre, Pa., Sept. 30.

THE Wilkes-Barre correspondent of THE MOTION PICTURE NEWS was in error a few months ago when he stated that no manager in this city would dare raise the price of admission above ten cents. One manager has come to the front, opened a new house and is asking twenty cents.

The new Nesbitt Theatre is now in operation under the direction of the Sun Amusement Company, managed by J. C. Rohn. The Nesbitt is without a doubt the best equipped motion picture theatre in northeastern Pennsylvania and has a seating capacity of 1,500.

The new owners leased the house from the Shuberts. Extensive alterations were made and when the Nesbitt opened to the public last Monday night, a Wilkes-Barre audience was given a glimpse of a real Metropolitan theatre.

The Nesbitt is so far ahead of other theatres in this section, that every other manager openly admits that "his house is no longer the prettiest in the coal regions."

It is estimated that the expense of

running the Nesbitt is \$150 a day. It was seen at first that it would be impossible to run the theatre at a 10-cent scale.

At various times managers have tried to get 15 and 20 cents for special features, but as a rule they played to empty houses. Manager Rohn refused to reveal the prices of admission to his house until the public went to the box-office on the opening night.

Several hundred dollars were spent in advertising the Nesbitt, but not once was the price of admission mentioned.

Mr. Rohn believed that if the public saw that 20 cents was being asked, they would think the amount too much and would not visit the Nesbitt to learn the quality of pictures being shown.

He said he kept the price a secret, has done a capacity business all week and firmly believes that several hundred film fans are already convinced that the Nesbitt programs are worth the "surprise price."

The Nesbitt is booking Paramount Pictures. Jack London's "Valley of the Moon" opened the house.

JOSEPH F. FORESTAL.

Exhibitors Declare War Tax An Injustice

Protests from Harrisburg and Washington Theatre Managers Against \$100 Levy on Theatres in Town of Over 15,000 Population Urge United Opposition to Fight the Measure—Some Think Size of Theatres Should Be Considered

THE proposed war tax of one hundred dollars to be assessed on motion picture theatres throughout the country to assist the government to raise \$100,000,000 in the deficit crisis, is considered unjust by exhibitors.

Their objection does not imply a lack of patriotic feeling or a desire to get out of paying their share of revenue. They object to a loosely drawn bill which works hardship on those who cannot afford to pay the hundred dollars.

Managers feel that the tax should be graded according to the amount of business done. It is obviously unfair to exact the same figure from, say, a man running a four hundred capacity house as the man who has a theatre holding one thousand.

The following reports contain vehement protests against the proposed measure, and the motion picture managers voicing these objections base their stand on facts which Congress should be apprised of before allowing the one hundred dollar tax to remain in the bill.

In this part of the measure, working such hardship on those who are least able to afford it, exhibitors see the value of solid organization, and decry the unpreparedness of the association at this time for making strong representations to the government at Washington.

The United Theatrical Managers' Protective Association, recently organized for the purpose of looking after the interests of "legitimate" and screen interests, have protested against the tax through Marc Klaw, who sent a telegram to the Senate Finance Committee last week, calling the attention of Congress to the grave injustice that will be exercised toward the industry if the one hundred dollar clause is retained in the bill.

Harrisburg Exhibitors Regard War Tax as Unjust

Special to THE MOTION PICTURE NEWS
Harrisburg, Pa., Sept. 29.

"It is outrageous to propose to put a war tax of \$100 on motion picture theatres," said J. M. Lenney, owner of the new Grand Theatre, at Fourteenth and Derry streets, and the Lenney Theatre, 5 and 7 South Thirteenth street.

"The exaggerated ideas the politicians have of the money-making ability of picture theatres is ridiculous. Here in Harrisburg each theatre now has to pay \$50 a year as city tax and \$25 a year State tax. By adding \$100 war tax the total will be \$175.

"This will simply drive the little fellows out of business. It is a great in-

justice, and I am in favor of our local organization doing whatever it can to help defeat the proposition. The ordinary politician overestimates by about 500 per cent. the earning capacity of a picture theatre."

"It simply means 'close up shop' for me," said W. N. Miller, who conducts the Summit Theatre, 1268 Market street, when he was shown the editorial in THE MOTION PICTURE NEWS explaining the plan of Congress to impose a \$100 war tax on motion picture theatres. Mr. Miller runs a small theatre of three hundred seats outside the central business section where he says he cannot charge more than five cents without losing his business to the bigger houses downtown, even though the latter charge ten cents.

Tax Would Close Many Houses

His case may be regarded as typical of those of many other small motion picture houses in this section of the State in which the proprietor and members of his family do almost all the work and are just able to make a comfortable living.

"One hundred dollars a year is about all I can expect to clear beyond a living and the payment of expenses," said Mr. Miller, "and if that is taken away from me by a war tax I will simply get out of business. I am patriotic enough to be willing to stand a part of the financial burden the war imposes on the government, but to tax a five-cent theatre with three hundred seats the same as a big ten-cent house with one thousand seats that can give many more performances a week than my house is the grossest sort of an injustice."

"At the next meeting of our local organization," said James George, manager of the Victoria, 223 Market street, "I am going to propose that we take what steps we can to protest against the one hundred dollar war tax. I believe this is an excellent opportunity to learn what organization can do for the motion picture business.

"Individual protests here have amounted to nothing in the past in the matter of preventing unfavorable legislation at the State capital. I cannot forecast what our local organization will do, but I feel very confident action against the war tax will be taken after the subject is thoroughly discussed by the members."

Urges United Opposition

"State-wide organization is the most effective medium for fighting the unjust war tax which Congress proposes to impose on the motion picture theatres," said Oliver Bender, of Bender Brothers, proprietors of the new William Penn

Theatre, which is about to be opened at Thirteenth and Thompson streets.

"I am a thorough believer in the saying that 'in union there is strength.' An individual protest amounts to nothing in a matter of this kind. The thing to do is to get together and let the lawmakers know that we will fight the imposition of this tax with full united strength of the men of the motion picture business. This should serve as an incentive for the various local organizations to be strongly welded together for their self-protection."

"This \$100 tax is entirely unjust," said Isaac Marcus, proprietor of the Royal, 1205 North Third street, the handsome new National Theatre, just opened at Sixth and Dauphin streets.

"Our local organization, I understand, is going to take the subject up at the next meeting when some practical opposition to the tax doubtless will be agreed upon. I am certainly in favor of an organized effort against such a discriminatory tax."

"I understand that overtures have been made to our local body to be affiliated with the State league, and I think this should be done."

Would Help Some

C. E. Hanshaw, for years a successful coal merchant, who has just opened a large motion picture house at Thirteenth and Harris streets, said:

"We have to pay fifty dollars for a city and twenty-five dollars for a State license, and now we are confronted with this additional one hundred dollar tax. I am brand new in the motion picture business and don't know much about the local organization of exhibitors. I say for the general principle of organization, however, that our local association of coal dealers has accomplished a great deal for that business and I am a firm believer in making a united stand to prevent injustice."

Isaac Silverman, of the Photo Theatre, 221 Market street, is opposed to the proposed war tax. "Sam has in some way to raise \$100,000,000 to offset the loss in revenue of foreign commerce due to the war in Europe. I would rather pay the hundred dollars than to see the price of foods and other necessities rise. Besides, the \$100 tax would benefit those of us who have theatre in the central part of Harrisburg, where the price of admittance, compelling the competing theatres to outlying districts, where they are a nickel, to put their prices on a level as ours."

Washington Exhibitors to Fight Proposed War Tax

Washington, D. C., Sept. 30. THE motion picture exhibitors are reacting with a strong protest against the proposed tax by Congress of \$100 for each theatre in a city of 15,000 population or over. Already Fulton Bralowski, secretary of the Exhibitors League of the District of Columbia and vice-president of the National League, has written to Congress setting forth the unjustness of such an indiscriminate regulation.

Tom Moore, who operates a chain of theatres, including the largest exclusive picture houses with seating capacities of 200 and 1,500, made these state-

ments all very well for the motion picture exhibitor to be taxed along with other amusements, but it is not fair for the man with the small theatre to be called upon to pay as much as his larger competitor.

Personally, I can readily afford \$100 for my large theatres, but it would work hardship with the smaller, residential theatres. Above all things, we must not let Congress to put a tax on the exhibitors; let the exhibitor have the tax, and let him regulate his own business to make up that amount as he sees fit. And he will not have to work a little harder perhaps, and pay more expenses here and there, or be content with a little less profit.

At six cents, nine cents and eleven cents for admission does not please the class exhibitor, and it is quite likely that patrons would not tolerate it. We must consider the patrons, for they are the source of revenue.

Of course, this is a matter for the National League to present to Congress. A mere handful of local exhibitors would have no weight at all. The local State organizations should collect data in their community and send it to the National League, so that they have all necessary facts to present to Congress. A hearing will be given to that organization and then the men at the capital will have the proper information at first hand. Something must be done and be done now."

Is Unfair

William Airey, manager of the Alhambra, was also interviewed, and he said this to say:

Of course, it is unjust to tax the motion picture exhibitor, indiscriminately. If the tax has got to come, it should be proportioned according to the capacity of the theatre. The picture exhibitor should be taxed the same showing as the big downtown theatres.

There are all sorts of more stringent regulations for fire, building, license and other things, and our Sunday shows must be conducted very quietly; yet the picture houses have practically the

same show on Sunday as during the week. There is no fairness in the matter. Congress thinks we are making all sorts of big money, but that's because it has not the facts. We must protest and we are going to protest."

Alan Backrach, manager of the Casino, who has charge of the picture end of the Brylawski chain of six theatres, also spoke of the unfairness of the tax as regards the capacity of the theatre. He also spoke of the unreliable information Congressmen appeared to have in hand as to the wonderful profits of the industry.

"Let them come look at the books of the motion picture theatres and the Congressmen will then see how we stand. Reels are getting more expensive, the service is more expensive, rentals are higher and regulations more exacting, and yet the price of admission is practically the same as when all these items were lower.

"Wherein comes the great profit? More than this, Congress should realize that at this present moment, with the war occupying the minds of the people, the motion picture business—in fact, all amusements—are suffering. The mind of the public is turning to reading matter of the war or its discussions and not so much to amusements. Our business has felt this greatly this summer and the outlook is not so promising for the fall.

"Amusements are always one of the first to feel the financial depression of any national movement. Through the local and national leagues Congress will certainly be given the proper facts. We are going to protest, to be sure."

Size Should Be Considered

T. H. Johnson, manager of the Maryland, with a seating capacity of little more than two hundred, was loud in his protest against being expected to pay \$100 along with his neighbors who operate houses of 1,200 and 1,500. "It is not just," he said. "Besides, there seems no reason why all kinds of business enterprises should not be included in this tax. Let the department store, the shoe man, and a whole lot of others help to pay this tax. I don't see how the small exhibitor can stand it. We can't raise the price of admission, for it is the low price that has brought us the people, and it takes a heap of nickels to make the price of one ticket in the big theatrical houses."

Harry Crandall, manager of Crandall's Theatre, was also of the opinion of the foregoing exhibitors in the unfairness of the amount set in the proposed tax.

"If we must come in for our share of the war tax, we are willing to do so, but it should be proportionate to the man's business," said Mr. Crandall. "Similar taxes have been proposed on railroad and other big corporations, but they have been nipped in the bud when the Congressmen realized what a power these corporations had upon their voting chances.

"Does the Congressman realize what a power the motion picture man has if he wishes to use it? Think of the millions who could in one day read about certain Congressmen tampering with an amusement which has become a vital source of the daily relaxation and education of the people.

"Some men now in Congress would soon begin to lose their popularity in their own community. Somehow the motion picture industry does not want to resort to that, but it does want justice and it is going to fight for it."

Advantage to Small Towns

In addition to the same protest of unjustness in the sum proposed for all exhibitors, Nat Glasser, manager of the Leader, made this point:

"The fact of making a tax less than \$100 for cities under 15,000 population is not fair either. For many of the small towns having fewer houses do a great deal more profitable business than the houses in the large cities. I know that from personal experience. The competition is less, rents are cheaper, and regulations are less exacting. Many an exhibitor in a town of 10,000 will be better able to pay a \$100 tax than an exhibitor in the city of 50,000.

"Besides, the motion picture is well recognized as of educational value, and it is also an important factor in community interests. All this should be taken into consideration when proposing a tax. It seems that it would be better if the manufacturer were taxed proportional to the film he produced, and then the exhibitor could better stand the slightly additional price of his service.

"For somehow the exhibitor gets the butt of it all, but he wants it as soft as possible. Of course, this is a matter for the National League, but it needs the co-operation of all local and State organizations. It is organization alone that will count."

ROCHESTER TOUCHED HIGH PRICE MARK

Special to THE MOTION PICTURE NEWS

Rochester, N. Y., Sept. 30.

Good business is reported from all sections of Rochester by exhibitors, both the downtown houses and those in the outlying districts enjoying excellent patronage. Though the weather has been warm and fair, the theatres have been thronged.

"Neptune's Daughter," featuring Annette Kellermann has concluded a three weeks' engagement at the Winter Garden, playing at twenty-five cents admission. That this picture was able to go through a three week's engagement, at the highest prices ever asked for motion pictures in Rochester, was a revelation to many of the local exhibitors.

It is realized that the picture is an unusual one, but the prices obtained and the length of the engagement taught many local picture theatre proprietors and managers a lesson.

POLICE CENSORSHIP BREAKS OUT AGAIN ON COAST

Department, Ignoring the Rights of Exhibitors Implied in the Stillwell Injunction, Makes Arrests on Flimsy Charges, Confiscates Films and Shows Unnecessary Activity—Managers Regret Not Taking Firm Stand at Beginning of Trouble

Special to THE MOTION PICTURE NEWS

San Francisco, Sept. 28.

THE censorship of war pictures in San Francisco has not come to an end, as might have been expected by the victories recently secured in the courts by exhibitors, notably the Silver Palace Theater Company and the Pastime Theater Company, which secured temporary injunctions against molestation by the chief of police, and that official will give no definite information when the ban will be lifted.

When his original order was issued to stop the showing of all pictures showing the armies of Europe in action, or mimic action, it was understood that it would be in force but a few days, or until the preliminary excitement had died away. It is now almost two months since the censorship of war pictures was taken over by the self-appointed censor, and both exhibitors and exchange men are chafing at the annoyances and losses that are being suffered.

Evils of Delaying Concerted Action

The general opinion is that a grave mistake has been made in not combining forces at the very start and making a vigorous stand against the order, as it is acknowledged on all hands that the chief of police has absolutely no authority to enforce such a ruling.

The brunt of the battle against this police censorship has been borne by a few, and while the latter have been successful in every case, new and trivial ones are being brought up constantly, and these exhibitors are being annoyed at every opportunity.

Why are the police officials of San Francisco persecuting the motion picture men of this city? That is a question that is agitating the minds of members of the trade. Not only are motion picture men being subjected to inconveniences, but the public funds are being wasted in making arrests on flimsy charges, in confiscating films, in obtaining search warrants, and much more excitement is being created than is caused by the exhibition of war films.

Undue Police Activity

The chief of police expresses the opinion that the display of war pictures may cause a disturbance in the audience of a theater, something that has never occurred here as far as is known. He thinks nothing of sending armed members of his force to a theater to break into the operating room seize films during a performance, arrest exhibitors and disturb the audience by loud and threatening talk. The only disturbances that have been caused in local theaters showing war films have

been provoked by the police themselves.

The arrest of Charles Stillwell of the Silver Palace Theater for showing the film, "Faithful Unto Death," was followed by his dismissal by the court and the granting of an injunction to prevent Chief of Police David A. White from interfering with the exhibition of war films there.

However, when an effort was made to show "The Kaiser's Challenge," this exhibitor was again arrested on the former charge, with the added charge of maintaining a public nuisance, the police objecting to the crowd that was attracted.

This arrest occurred on a Saturday afternoon, when it was probably felt that it would be impossible to secure the \$600 bail money demanded, but the sum was raised, and Mr. Stillwell was released, the films being held. When this case came up for hearing later the charges were dismissed.

The Apex Film Company, which owns the feature, "The Kaiser's Challenge," has engaged Attorney A. S. Newburgh, Pacific Building, to contest the right of Chief of Police D. A. White, and Peter Peshon, of the censorship board, to interfere with the exhibition of this and similar films.

File Damage Claim Against Police

A damage suit has also been filed against each of these in the sum of \$500 to cover losses that have already been sustained, and Mr. Newburgh is confident that damages will be awarded.

Judge J. M. Seawell, of the Superior Court of San Francisco, recently issued a restraining order, and an order to show cause, the plaintiff being P. P. Graft, doing business as the Apex Film Company, and the defendants D. A. White and Peter Peshon. To show the scope of this it is appended in full, as follows:

"The plaintiff having filed herein a verified complaint from which it appears that the defendants and persons under them and by their orders, without right, prevent the plaintiff and plaintiff's customers and patrons from exhibiting in this city and county of San Francisco, a certain moving picture called 'The Kaiser's Challenge,' and other moving pictures of a kind similar to said 'Kaiser's Challenge,' of a class of pictures known as war pictures, and that if said prevention continues the plaintiff will suffer irreparable injury and that the plaintiff has no adequate remedy at law for such injuries and it appearing that this is a proper case, therefore;

It is Ordered, That defendants show cause before this court in Department One thereof, at the hour of ten o'clock,

on the 25th day of September, 1914, and then and there show cause why a temporary injunction should not issue out of this court restraining the defendants and all persons and officers of police of the city and county of San Francisco during the pendency of this action from preventing the exhibition of said moving pictures or interrupting the exhibition of the same or from seizing the same.

Ordered to Keep Hands Off Films

It is Further Ordered, That in the meantime and until the further order of this court, the defendants in this action and all persons acting under them or either of them, and said officers of police are restrained and enjoined from preventing or interrupting or hindering the exhibition of said war pictures in the city and county of San Francisco, and from intimidating and deterring proprietors and managers of moving picture theaters in said city and county from exhibiting the same by threats that the exhibition of said pictures will be suppressed, or that persons exhibiting the same will be molested by the police of said city and county; and from seizing and detaining said pictures."

The tactics of the police force may be judged from the fact that while the Silver Palace Theater was allowed to run "The Kaiser's Challenge" for two days without molestation, following the release of the films and the dismissal of the case against Charles Stillwell, the proprietor of another house on Market street was warned later that any attempt to show the feature would result in his arrest.

This theater owner was compelled, through these threats to remove all posters from his place of business and to cancel his orders for service.

Attorney A. S. Newburgh states that this matter of censorship is not a new one in this city.

Play Restrained at Alcazar

A series of mysterious murders had been committed here and during the trial of the degenerate Durant the Alcazar theater advertised a play called "The Crime of the Century," this being based on the famous case. The judge of the Superior Court, whose authority greatly exceeds that of a chief of police, attempted to interfere with the production and issued an order to prevent its being shown.

When the play was staged, Manager W. R. Dailey and actors were arrested and fined, and some were sentenced to imprisonment. The matter was taken to the Supreme Court, and the order of the lower judge was annulled on the

grounds that a drama was only a story in words, and as the play was not suggestive, there was nothing in the constitution to prevent its being shown.

In the case of war pictures, these are merely photographic reproductions of current events, and in the opinion of legal lights are no more liable to police interference than are the daily newspapers.

Article 1, Section 9, of the State Constitution reads: "Every citizen may fully speak, write and publish his sentiments on all subjects, being responsible for the abuse of that right, and no law shall be passed to restrain or abridge the liberty of speech or of the press."

This section of the State Constitution is plain enough in its guarantee of personal rights to the citizens of the community and it is hoped that the police department will be compelled by the courts to acknowledge this right. The exhibitors feel that the matter has gone far enough.

BOISE CENSOR LIKELY

Special to THE MOTION PICTURE NEWS

Boise, Idaho, Sept. 29.

The proprietors of motion picture theatres are somewhat up in the air over the stir here for a city censorship board, which is being agitated by one of the newspapers in the city, spoken of favorably by the mayor and endorsed by the Boise Ministerial Association.

Not being organized locally or having a state organization in Idaho, the theatre managers are not in a position to make a combined and drastic fight against the appointment of a city censorship board. All but one theatre manager, however, is bitterly opposed to such action upon the part of the city's head, and feels that it would be a rank injustice to the business, especially when Boise is located several hundred miles from a film exchange.

600 AT OPERATORS' FETE

Special to THE MOTION PICTURE NEWS

Los Angeles, Sept. 28.

Final reports were made by committees in charge of the benefit entertainment recently given by Local No. 150, I. A. T. S. E., at the regular meeting of the union, and a goodly sum was turned over to F. A. Sawyer, financial secretary.

The entertainment consisted of a "Movie Medley," given at Labor Temple Auditorium, and attended by more than six hundred, who paid an admission fee of fifty cents.

ARKANSAS TOWN HAS NEW THEATRE

Special to THE MOTION PICTURE NEWS

Arkadelphia, Ark., Sept. 29.

The New Royal Theatre has opened. Manager Belaschke, who is interested in the Royal Theatre of Little Rock and motion picture houses in Hot Springs, has leased and is operating the New Royal here.

California League Ready for Convention

Members Expected to Make a Strong Showing in San Francisco on October 6-9—Exchange Men and Producers Invited

Special to THE MOTION PICTURE NEWS

San Francisco, Sept. 28.

THE California Motion Picture Exhibitors League will hold its annual convention in Convention Hall, Phelan building, San Francisco, October 6-9 inclusive.

The league has extended a cordial invitation to exchange men and producers for the purpose of promoting harmony among the various branches of the industry.

It is expected that a large number of visitors directly interested in the motion picture business will attend, and the organizers predict an assemblage numbering a thousand exhibitors.

At first the city of Sacramento was selected for the conclave, but San Francisco was finally agreed upon by the members of the organization on account

of its location and its nearness to the exchanges.

The entertainment committee has planned a sightseeing trip on a large automobile for the guests, and has chartered the steamer *Arrow* for an afternoon's ride on the bay. A masquerade ball will be held at Wurlitzer's Music Hall, where Mayor Rolph will lead the grand march. A banquet is scheduled for the occasion, at which Governor Johnson will preside.

J. Ray Williams of Sacramento; A. P. Tugwell, M. E. Cory, F. R. McCauley, R. L. Marks, Joe Huff, C. L. Langley, George Knowles, Charles Goddard, president of the M. P. E. L., W. H. Hills of San Diego, H. L. Black of Oakland, W. A. Cory and Mr. Mehrrens of Berkeley, are on the entertainment committee.

Rochester Wants New Exhibitors' Club

Several Managers Dissatisfied with the Old Organization—Local Association Having No State or National Affiliations Is Proposed

Special to THE MOTION PICTURE NEWS

Rochester, N. Y., Sept. 30.

THERE is a growing sentiment among those connected with the motion picture business of Rochester that there should be a strong organization here, such as a Screen Club, through which those engaged in the business might become better acquainted with one another, and work to better advantage.

There is an organization of exhibitors at present, but, owing to the political situation in the state and national organization, it is not very active and its meetings are not very largely attended. It stuck to the old ship when the big break came some time ago, and has been lying low for months.

Some of the men engaged in the motion picture business here are beginning

to talk about the formation of a Screen Club, and it would not take much urging to induce the majority of men here to join such an organization, the club to be entirely independent of other organizations, state or national.

"We never have an opportunity to get together for business or pleasure," one of the younger men in the business said, in discussing the project.

"There are many of us who would like to do so, but the way does not seem to be open through the local exhibitors' league. If some one would take the initiative, a club could be formed readily, and started off with a whoop. It would soon become a powerful factor, too, in the motion picture business of Rochester."

ARTHUR R. TUCKER.

California League Blocks Segregation Bill

Organization Shows City Council Impossibility of Dividing Theatres to Keep Sexes Seated Apart During Performances

Special to THE MOTION PICTURE NEWS

Los Angeles, Sept. 28.

MOTION picture theatres of this city will not be forced to have separate sections for men and women, and women with escorts, as was the desire of Chief of Police John Sebastian, as a united effort of members of the exhibitors' league, led by the president, Judge A. P. Tugwell, succeeded in killing the segregation ordinance when it came up for hearing before the public welfare committee of the city council.

The ordinance was framed by the city attorney at the suggestion of Chief Sebastian after the police department had received complaints from women and girls that mashers frequented the motion picture theatres. The police of-

ficer thought it would be impossible to prevent flirting unless the sexes were segregated and recommended the ordinance.

The exhibitors in the defense of their rights, and to prevent further action on the part of the police, showed that such an ordinance would increase the daily expense because of the need of additional ushers; that at times it would be necessary to keep many people waiting outside in case there were more men than women or vice versa; and that inasmuch as various religious denominations had for centuries tried to segregate the sexes and failed, it was more than probable the motion picture theatre managers would be unsuccessful.

J. C. JESSEN.

Milwaukee Exhibitors Dissolve Association

Lack of Support on Part of Members Brings One of the Best-Known and Most Active Exhibitors' Bodies in the Country to the End of Its Existence—Phillips' Final Appeal Calling Upon the Managers Throughout the State to Stand by Milwaukee, Is Vain

Special to THE MOTION PICTURE NEWS

Milwaukee, Wis., Sept. 29.

THE Motion Picture Association of Milwaukee is to disband and with it will undoubtedly go the newly organized Wisconsin Photoplay Association, as the local exhibitors make up the major part of the State organization.

This disbandment will come as a distinct shock to the exhibitors all over the country, for the local organization was the one that so successfully combated the censorship agitation in this city and which succeeded in having the local citizens' committee appointed, a body which the National Board has recommended as a model to all cities endeavoring to solve the censorship problem. The Milwaukee Association was also honored by having one of its members, C. H. Phillips, president of the International Motion Picture Association.

The letter, calling the meeting to disband, is dated September 26 and is signed by S. Trinz, the secretary. It is as follows:

IMPORTANT.

Mr. Exhibitor:

The directors of the Motion Picture Association of Milwaukee decided to call a meeting Friday, October 2, 1914, for the purpose of disbanding the association and making a division of the money in the hands of the treasurer in proportion to the amounts paid by the respective exhibitors.

The reason for taking this step is the lack of interest shown by the exhibitors in organization for the protection of their interests.

The amount in the hands of the treasurer runs into three figures, and we have decided that only the exhibitors who will appear at the meeting will participate in this distribution.

Now, therefore, if you fail to appear as above stated, you will not be one of those who will derive the benefit of this fund.

Respectfully yours,

S. TRINZ, Secretary.

"We have been forced to take this step," said Mr. C. H. Phillips, counsel for the organization, "on account of the attitude of many of the local exhibitors, an attitude that can be best illustrated by a speech made by one of the Milwaukee exhibitors who when he was approached for his dues, sent word that he could get along without those —."

"I am very sorry that this should come up at the very time that such a

splendid campaign is being waged for new members, but we have no other course left to us."

Mr. Phillips' last act was to send a state-wide appeal to all Wisconsin exhibitors to support the new organization.

In his speech at the opening of the convention at which the State body was organized, Mr. Phillips made an urgent appeal to the State exhibitors present. Owing to the fact that many were not present, however, he for the last time made an appeal to the State men through the columns of THE MOTION PICTURE NEWS.

"I am today appealing to all the exhibitors in the State to help in the work of organizing a strong association in the State preparatory to fighting proposed legislation to be introduced in our next Legislature.

Urges Exhibitors to Respond

"It seems to me that the exhibitors in this State do not realize the necessity of organization and have not responded as they should.

"The Milwaukee exhibitors are organized, and unless the exhibitors outside of Milwaukee will join the State organization, Milwaukee will take care of its own interests and protect itself against any legislation which might affect the city of Milwaukee.

"The only legislation that might affect Milwaukee is the censorship bill.

"Two years ago Milwaukee exhibitors defrayed all the expenses in successfully killing seven legislative bills introduced, several of which had no effect on Milwaukee exhibitors.

"We will now put ourselves on record, and I speak for the Milwaukee exhibitors, that *unless the exhibitors* who failed to join the organization or respond to the call of this convention *will come in* within one month by paying their dues *as requested in the call, Milwaukee will withdraw from the State organization and take care of and protect its own interests.*

"Milwaukee asks for nothing and wishes to make itself understood that it is not looking for offices.

What Seven-Day Law Means

"Milwaukee exhibitors do not any longer intend to assist those who cannot see the danger in adverse legislation which would eventually put them out of business.

"*And the only successful way to fight legislation is through organization; individually one cannot accomplish anything.*

"Do you know what it would mean to you if the seven-day rest law should

be passed by our Wisconsin Legislature?

"You would be forced to employ an extra force for the seventh day in order to enable you to continue your business on that day.

I therefore appeal to you, gentlemen, to come in and assist us in our efforts to protect our interests.

"Milwaukee is capable of taking care of its own affairs and has always contributed largely to that end; and to prove that I ask you, gentlemen, to look at the work already accomplished in preventing legislation in the city of Milwaukee *that would have put many of the small exhibitors out of business.*

"You gentlemen from outside of the city of Milwaukee, do not seem to realize what organization means.

"Less than two years ago the city of Racine called me to their city as president of the then alleged State organization, and also as vice-president of the International organization, to appear before a committee of their Common Council against the sixteen-year-old child ordinance, with which ordinance Racine was then threatened.

Individuals Powerless

"After I had shown to the committee the dangers in which it placed the exhibitor, the Mayor stated: 'After hearing the gentleman from Milwaukee I move the indefinite postponement of this ordinance.'

"It was indefinitely postponed and has not since been touched.

"This same ordinance was successfully killed in the city of Milwaukee together with many others.

"If the exhibitors had appeared before this committee in their individual capacities, this could not have been accomplished because without organization legislative bodies will pay no attention to the individual for the reason that they know that it is not for the protection of the entire industry.

"And the exhibitors, unfortunately, whose investments are enormous, are the only large industry without proper organization.

"The merchant and manufacturer, the professional man and the retailer all have organizations intent upon protecting their interests.

"You gentlemen from outside of Milwaukee are not playing the game squarely because you believe that Milwaukee exhibitors, who have all the time championed your cause, will continue to play the game for you.

Yet Time to Respond

"Milwaukee is square and is asking for nothing but a solid organization and,

contrary to apparent belief, is not working for its own aggrandizement, but rather for the good of the industry throughout the entire State.

"There is yet an opportunity to respond to the call, and unless very shortly definite arrangement is reached between the exhibitors of the city of Milwaukee and the exhibitors of the State, the exhibitors of the city will take the matter into their own hands and feel themselves relieved of the responsibility attendant upon the welfare of the exhibitors in the State of Wisconsin, *outside of Milwaukee.*" I. W. MARTIN.

AN EDISON COMEDIENNE

Gladys Hulette, although comparatively young in years, has had a large amount of stage experience. She has



GLADYS HULETTE

played under such stars as Bertha Kallich, Mme. Nazimova and Henry Miller. Her last appearance on the stage was made in 1911, when she played Beth in "Little Women." Since that time she has been with the Edison company.

GREY GOES TO MUTUAL

John W. Grey, formerly with the Universal Company as advertising manager, is now associated with the Mutual Film Corporation in special advertising and publicity work. His extensive experience in the motion picture advertising field well qualifies him for his position, and the Mutual Film Corporation is to be congratulated for securing his services.

DYREDA IS UNDER WAY

The Dyreda Art Film Corporation, of which Frank R. Dyer is president, and J. Searle Darby, director, is located at Room 1009, Candler Building, 220 West 42nd street, New York City. Mr. Darby, who was formerly director for the Famous Players Film Company, is working on a big scene of their first production.

Florida League Holds Third Convention

Mile of Film Preserves Event—Carl Kettler Again Elected President—Tano Appointed Organizer to Canvass State

Special to THE MOTION PICTURE NEWS

Tampa, Fla., Sept. 29.

THE third annual convention of the Florida branch of the Motion Picture Exhibitors' League of America was recently called to order by Vice-President Kettler, of West Palm Beach, owing to the absence of President O. Griffith, of Tampa, at the Bijou Theatre, West Palm Beach, with fourteen members present.

Several matters of vital importance, not only to exhibitors but to the patrons of the motion picture theaters throughout Florida, were discussed, and several resolutions adopted. Letters of regret for non-attendance from some twenty members were read and placed on file.

Applications were read from eight parties desiring to become members of the league and by the regular proceedings they were elected to membership. The meeting was then adjourned to 2 p. m.

In the afternoon, after several matters of business had been taken care of, and after speeches by Vice-President Kettler, A. A. Tano, and Louis Kalbfield, nominations were declared in order for offices of the league for the ensuing year, and the following were elected: President Carl Kettler, Jr., of West Palm Beach; Vice-President, L. H. Kalbfield, Palatka; and Secretary and Treasurer A. H. LaBelle, of Tampa, Fla.

The followed directors were also elected: Carl Kettler, Jr., Bijou Theater; W. P. Beach; L. H. Kalbfield Grand, Palatka; A. H. LaBelle, Grand Theater, Tampa; L. Halliman, Crystal, Fort Pierce; A. A. Tano, Dixie, Kissimmee; S. J. Harvey, Star, Milton, and A. A. Torres, Airdome, Key West; and W. S. Moreland, Arcade, W. P. Beach was elected next vice-president of the Florida branch.

All the newly-elected officers were immediately installed in office, and after appropriate speeches the meeting was adjourned to 10 a. m. Tuesday, September 15.

At 10 a. m. Tuesday, September 15, the meeting was called to order, and after some discussion, A. A. Tano was elected Florida organizer. Mr. Tano, being a very good speaker, and being familiar with the work, will canvass the entire State for the advancement of the league. It is expected that his efforts will gain many new members.

It is believed by exhibitors attending the convention that Mr. Tano's election constituted the creation of an office new in the motion picture industry, and they believe that the plan of increasing membership by personal solicitation will result in bringing practically every manager into the organization.

After farther discussion of impor-

tant matters, the meeting was brought to a close by an apt and characteristic speech by President Carl Kettler, Jr.

The next convention will be held at Palatka when Mr. and Mrs. Kolofield will entertain the exhibitors at a date to be set later.

The Florida State branch has at present thirty-five members, and has been in existence just one year.

The State branch tendered a vote of thanks to President Kettler, the Board of Trade, and the citizens in general of West Palm Beach for their entertainment, which began the moment they arrived and lasted until the last exhibitor was on board the train, homeward bound.

Besides being entertained every moment while not engaged in actual business, special features were pulled off at Gus' Baths and the Flagler Houseboat. Every one had the time of their lives.

Among the various film men present were: F. S. Laubert, of the World Film Corporation, Atlanta; Byron S. Bryan, of the Eclectic Feature Film Exchange, Atlanta; Mr. Chivers, of the Paramount Features, Atlanta, and W. C. Burgert, of the Universal, Tampa.

W. C. Burgert had his moving picture camera with him, and took a mile of film which will be run in various Florida houses, as soon as finished.



ETHEL BARRYMORE IN A SCENE FROM "THE NIGHTINGALE"
(All Star—Alco Feature)

Film Men Cry "Hands Off" To Cleveland Mayor

Secretary of Victor Exchange Points Out to Official That Courts Have Released Thirty Out of Thirty-two Exhibitors—Operators' Strike Settled—Men in Downtown Theatres to Get \$2.50 and Uptown Booth Employees a Two Dollar Advance

Special to THE MOTION PICTURE NEWS

Cleveland, Sept. 30.
"THE White Dove of Peace," long absent from the Cleveland motion picture field, last week passed the first milestone on his return trip to the city. One complication was removed from the Cleveland exhibitors' and operators' dispute when both parties to the wage increase asked by the operators compromised and settled the question. The latest settlement is to be permanent, it is hoped. Three weeks ago a temporary agreement was reached, whereby the operators were granted a \$2.50 a week increase throughout the city.

Submitting the proposition to further arbitration resulted in the \$2.50 increase being granted only to downtown operators. The uptown operators will receive an increase of \$2 a week.

The operators originally asked for a general sweeping increase of five dollars per week over the minimum wage of fifteen dollars per week. During the arbitration period, considerable ill feeling was occasioned by the alleged indifference with which the exhibitors viewed the demands of the operators, and the tardiness with which the demands were discussed.

Other Disturbing Questions

Even with the operators' wage scale decided, Cleveland exhibitors are not pervaded by a warming inner glow of satisfaction.

To compete with the tang of the autumn air, there are hanging fire for Mr. Exhibitor's attention, other things. The exorbitant demands of the musicians, the threatened revival of local police censorship, the war on "war" posters which can not display an unquestionable pedigree, and attacks upon the intellect of Mayor Newton Baker, are just at present adding to the zest of life.

The fire kindled by the musicians is smouldering at present and the wrath of the motion picture men is directed at Mayor Baker, whose policies in the regulation of films are being bitterly assailed.

C. G. Thompson, secretary-treasurer of the Victor Film Service Company, in a letter which he sent to Mayor Baker on Thursday, told the official that Cleveland motion picture men have reached the end of their patience in enduring Baker's continued criticism of their methods and their business.

Thompson's Letter in Full

Particularly did he score the mayor because of Mr. Baker's act in giving the police almost unlimited powers to censor and confiscate films and posters.

The letter is here given in full:

"In addressing you upon a subject of vital importance to myself and others, I do it with greatest respect for the lofty position you hold, but nevertheless I feel that I would not be doing my duty if I longer hesitated. For nearly a year you have in every possible way shown contempt for the picture show business and for those engaged in the same. In December of last year you caused wholesale arrests of proprietors of picture shows and now you are placing your ban upon posters.

"You do not seem to realize that you have been making war upon an extensive business in which more than \$3,000,000 are invested in the city of Cleveland, and more than 2,000 people given steady employment, and more than 50,000 entertained every night.

"Last December you made the police censors of pictures and the courts of this city found them wrong in thirty out of thirty-two cases and in one of the two cases the board of censors of the state of Ohio disagreed with the courts, and the other was a film that had been shown by the city of Cleveland in the parks.

Pictures Passed National Board

"You would no doubt be surprised to know that no pictures are shown in Cleveland except those passed by the National Board of Censors, of which Frederick Howe is one, and you would perhaps no doubt disagree with Mr. Howe in his condemnation of legal censorship.

"For some months last winter you forced us to go down into our pockets and pay your friends for looking over the films shown in Cleveland, without legal authority and without resulting in any change in our policy. While we may have no fault to find with the work of your censors, we feel that if you had been a fair-minded man, that you would have given the public the truth about a subject that we paid by your threats to enlighten you upon.

"You are at the head of the city of Cleveland and in close touch with the police and juvenile courts, and if picture shows were as you seek to convince the public they are you surely could gather proof from the courts.

"You know you have no proof; you admit you never go to a picture show, yet you pass judgment upon the Westenhaver ground that what you say and do is right and all else is wrong.

Good Pictures or Bad Dance Halls?

"Do you think the boys and girls of this great city are worse off in picture shows than they would be in company with some of your colleagues in places

frequented by them and, I might say, controlled by them? Would you have all the youth of this city leave the picture shows and attend municipal dance halls for the good of their morals and keeping them from temptation?

"After your experience with the police censoring film last winter, you start them out now passing on posters. Has their judgment been quickened since then that they are now able to make better showing of good judgment than they did with the film?

"Did you know that nearly all the posters used by the picture shows in Cleveland are made here and that four hundred people are given steady employment making posters for picture shows alone?

"You seem to take a position similar to the Governor of Ohio, who in a recent speech before picture men in convention assembled, boastingly said, 'I know more about censoring film than any of you.' What has become of the great principle of democracy in this age, when the chief exponents of it are seeking to place a guardian over every man's business and morals?

"Personal Liberty—What About It?"

"It is a well known fact that in your attempt to choose the representatives for the people you sought a number of ardent members of the Personal Liberty League. Now let me ask you if those representatives apply the principles of personal liberty to simply one class and not to the pictures, upon the principle that the picture men are not upon the same level as the chosen ones?

"Did you not hear the rumbling of discontent at the last primaries against your arrogant manner of trying to boss the people who elected you? You seem to assume that men of intelligence and character do not go to picture shows; but in this let me assure you that you are mistaken and perhaps the reason you have failed to discover the fact may be for the reason they are not proclaiming the fact from the house tops, nor are they seeking to measure every man in their half bushel. You are absolutely without any evidence or facts to substantiate your position except your own narrow and prejudiced conception.

"If you think the men engaged in this business are inferior in mind and morals I would gladly arrange a meeting where that notion may be corrected.

"If you think that degenerates could carry on a business involving \$30,000,000, just give them 'the once over.' If you think the people who attend the picture shows are of the susceptible kind without minds, people who need guardians, just step into a few of the shows and give yourself a big surprise.

"If you think the makers of posters are not looking after the welfare of our citizens just make a visit to the Morgan and Otis lithograph plants and see what kind of business you seek to destroy.

"Let me say that you have gone far enough in your relentless fight against the interests of a legitimate business, and patience has ceased to be a virtue and you will find the picture men standing shoulder to shoulder in a fight for their rights and the 50,000 persons who nightly attend their places will be the final judges of what is right.

"Yours, etc.,

(Signed) "E. G. THOMPSON."

No Law to Hold Him

Sam Bullock, proprietor of the Boulevard theatre, Lorain avenue and West Ninety-eighth street, escaped being sacrificed as the first victim in Mayor Baker's censorship crusade, only to fall into the hands of the operators' league, which promptly established pickets about the theatre and succeeded in turning away trade because Mr. Bullock employed a non-union operator.

Patrons and would-be patrons of the theatre were handed cards bearing a short plea for no patronage.

But to return to the escape from court. About three weeks ago Mr. Bullock was arrested, charged with violating a statute prohibiting the exhibition of unlicensed films. On Thursday he was discharged from police court.

The state claimed films exhibited by Bullock did not bear a "leader" announcing passage of the film by the Ohio Board of Censorship. The state also showed that the absence of such a leader constituted an offense.

Handily, the statute fails to provide a penalty and this was the salvation of Mr. Bullock. Judge Sanders could not fix a penalty where one had not been provided and had no alternative than to discharge Mr. Bullock. Exhibitors consider the lack of a penalty a clear indication that the police have acted beyond their authority.

Attempt Boycott

The manager's troubles were not yet over. In the fight between the exhibitors and operators over a higher wage scale, Mr. Bullock had refused to pay the increased scale, even after arbitration had been concluded.

Therefore, the International Association of Theatrical Stagehands and Employes, with which the operators' league is associated, on the order of the Cleveland Federation of Labor, stationed pickets about the theatre and for three weeks yellow cards bearing the statement: "Union men, friends and sympathizers—Don't patronize the Boulevard theatre, Lorain avenue and West Ninety-eighth street. It is unfair to organized labor. Stay away," have been handed out. The danger of fire when an unlicensed operator is in the box is the argument used on the back of the card.

Operators' Law Killed In Los Angeles

Public Welfare Committee Upheld by Council—Ordinance Would Make It Imperative That Only a Licensed Man Be in the Booth

Special to THE MOTION PICTURE NEWS.

Los Angeles, Sept. 28

AN ordinance affecting the local exhibitors recently came up for hearing at the meeting of the public welfare committee. This ordinance is fathered by the Los Angeles fire commissioner and City Attorney Stevens and provides that only licensed motion picture projecting machine operators shall be allowed to work in the projecting room.

Should this become a city law it would, the exhibitors agree, cause additional expense because at the present time helpers do much of the work of rewinding films, cleaning machines, etc., and in suburban theatres open only in the evenings, where the work can now be safely done by an operator and helper, it would increase the expense from twenty-five to forty per cent.

Furthermore, it would stop additional people from learning to operate, thus reducing the number and ultimately making it possible to force exhibitors to pay higher wages.

At the present time an ordinance prescribes that all motion picture machine operators must first secure a license, and to do this it is necessary that they take and successfully pass an examination given by the city electrician. This examination costs the operators five dollars in case they are successful and nothing if they fail. The license is revocable at any time.

The pending ordinance has twice been killed. Prior to the hearing by the public welfare committee of the city council, exhibitors were notified of the ordinance, and about sixty were present to voice their protest. The committee, after hearing remarks by several exhibitors, voted that the ordinance be reported unfavorably.

When members of the operators' union learned of this, the officers secured permission to appear before the city council and explain the purpose of the ordinance.

Secretary P. H. Whitman, of the Union, made the principal address, in which he showed that when the ordinance now effective was passed, there were but thirty-five theaters and fifty operators in Los Angeles.

"Now there are 847 licensed operators and more than 100 theatres," he explained.

It was further claimed that licenses were held by some exhibitors who employed small boys to operate machines, and that these exhibitors seldom entered the booths. Instances of motion picture operation schools being conducted in down-town theaters during running hours, where apprentices were permitted to run the machines while the regular licensed operators could visit with the box office girl were cited.

The argument advanced by the exhibitors' representative, Judge A. P. Tugwell, president of the local league, and member of executive board of National League, was, that the ordinance would give the union operators a monopoly here, and that it would be impossible for additional men to learn to operate the machines, if they were not permitted in the booths during running hours at the theaters. He also contended that it would be far more expensive for the exhibitors, as it would necessitate better wages for licensed men, while in reality inexperienced boys could rewind films and thread machines satisfactorily.

Referring to the question of safety to the public, President Tugwell stated that non-union men were more careful than the union operators, and that there had been more fires in Los Angeles theaters employing union men, than in those employing non-union.

After spending more than an hour in hearing both sides of the question, the members of the city council, with the exception of one member, voted to sustain the report of the public welfare committee.

J. C. JESSEN.

Texas Sunday Closing Law a Dead Letter

Not Enforced in the Large Cities—Dallas Ex-Minister Files Complaint Against Managers, but Jury Fails to Convict

Special to THE MOTION PICTURE NEWS

Dallas, Sept. 28.

WHILE there is a state law against Sunday amusements in Texas, it is not enforced very strongly, especially in the large cities. Under this statute motion pictures have been held to constitute a violation of the law.

Two or three years ago a referendum vote was taken in Dallas and the residents voted more than three to one in favor of Sunday amusements. Since then various attempts have been made to close the film theatres on Sunday without effect.

The latest effort was made by Rev.

George Owens, a retired minister and millionaire lumberman of Dallas. He filed complaints against the managers of three theatres operated in Oak Cliff, a suburb of Dallas.

At the trial of one case the jury returned a verdict of not guilty in a few minutes after they had been charged by the judge. There are now on file in Dallas alone over four hundred cases against film men for operating in Dallas motion pictures on Sunday. The authorities admit that it is useless to prosecute as it is impossible to secure a jury that will convict.

E. R. HAMBRICK.

Conditions Everywhere Demand Organization

Too Much Jealousy Among Exhibitors in Albany, but Need of United Action Is Urgent—Ohio Exhibitor Complains of League Methods—Finnegan, of Dallas, Defines Advantages of Union—Arizona Exhibitors Indifferent—Managers in Kentucky Enthusiastic

Special to THE MOTION PICTURE NEWS

Albany, N. Y., Sept. 30.

AT present organization is not in the minds of the Albany motion picture managers. The managers who have been interviewed, cannot see organization in any form. They declare they can't see where they can benefit out of a city, State or national body. Some of those interviewed point to the organization Neff led, and give that as a basis of their argument.

Joseph Weidman, owner of two film houses, and one of the best versed men in Albany motiondom, is for organization, but one that would be run the same as a labor union; that is, such as the Typographical Union.

Such an organization would be a benefit to all, he declares.

"There is very little talk of organization in Albany," said Mr. Weidman, "and the reason is that there is too much jealousy among the city managers. Two or three of the local owners are in the Eastern New York Exhibitors' League, which is made up of vicinity show houses.

Found Price-Cutting Going On.

"Locally, we have tried to regulate matters by forming a local body to be affiliated with one of the upper bodies. This proved to be an absolute failure, as the managers were not fair to each other. The endeavor was to get all the houses to run shows of equal length for a set price of admission. In this way we believed the business at all the theatres would be better.

"The first thing we found out was that some of the larger houses were running six and eight reels for the small sum of five cents, which was utterly impossible for the smaller houses to do. It was then we learned that an organization in Albany would be a joke, and now everybody is out for himself.

"As a result some are not doing the business they should. I believe in organization, and I honestly believe that there should be a local league in each city to be affiliated with a State league, the State league to be a part of the national body.

Screen Can Help the Politician.

"The effort of these leagues should be to have a representative elected to the legislatures of each State, so as to fight for or against the bills that have a bearing on the motion picture business. Everyone interested in the game should realize that the motion picture institution is one of the greatest in the country and should have representatives in these State bodies.

"I will not stop here, as I believe *there should be an effort to have representation in Congress, or at least try*

and elect men to that body who will have our interests at heart.

"This may sound like a joke to many, *but there is not a body of men anywhere who can do more for a political candidate than the men of the film world.* Look at the screens they control throughout the country, and figure how many men see what is shown on these screens. If such and such a candidate was given a slide each night in the theatres it would do more for him than a newspaper.

"I will not say any more now, but later I will have something to tell which should prove interesting to the exhibitors. In closing, I repeat that there should be organization."

Dissatisfied With Conditions in Ohio

Special to THE MOTION PICTURE NEWS

Canton, Ohio, Sept. 29.

SPEAKING on the subject of organization among exhibitors, J. A. Bernower, manager of the Alhambra Theater (Market and Avenue N), of this city, cites what he claims is a condition that has grown in Ohio to a point where careful attention and an immediate remedy is necessary.

"Organization is the thing needed to place motion picture exhibiting on a solid business footing," says Mr. Bernower, "but before a workable organization can be effected in this state the Ohio branch of the National Motion Picture Exhibitors' league will have to become much more active than it has been in the past."

Lack of Efficiency Is Alleged

"A few words from my own experience will suffice to show what I believe to be lack of effort on the part of the branch in the past. I joined the league over a year ago, and paid my fee.

"I have never received a copy of the constitution and by-laws and am not even certain such things are in existence. I recall having received two or three letters from the league. That is all. One of the letters, I remember, was a notice of a meeting.

"Now, I am no organizer. Because of this perhaps, I have no right to be talking. Some one of the league should make it a business to keep in closer touch with those who are won to membership.

"Every thinking man in the exhibiting business, and most of those in the business are thinking men, knows that organization is a good thing. I should think there are plenty of ways to point out to them the necessity of joining the league at once in order to make it an organization of strength.

"For instance, we all know that different laws are to be found in almost every community in the state. Exhibitors would like to have a uniformity of rules throughout the state.

"The state legislature could be induced to pass a law bringing about such uniformity. If a league of all the exhibitors in the state asked such a favor of the legislature, would it not have effect?"

Exhibitors Want Uniform Laws

"In Massillon, two miles west of here, in the same county, theaters are not allowed to show pictures on Sunday, while no attempt to so curtail the business is made here. How is that? Couldn't a well-organized state league provide a remedy for a condition like that? It ought to be easy to convince an exhibitor that the league could.

"I suggest that the exhibitors who are holding back membership be told of the things that the league could and would do if their support were lent. The state legislature will meet next January. The motion picture exhibiting business is a big business in Ohio now.

"It is certain that laws affecting this business will be proposed in the next session. Can individual exhibitors attend the legislative sessions and watch those bills? Well, the league could. Anyone can figure that out. Let's have a little more 'pep' in the state league of Ohio."

Organization Will Do Away With Censorship

Special to THE MOTION PICTURE NEWS

Dallas, September 28.

"THE needs of organization of the men engaged in the business of entertaining the public through the medium of motion pictures is too apparent to any thinking man to need any argument in its favor," was the way T. P. Finnegan, manager of the Hippodrome at Dallas, answered the question of THE MOTION PICTURE NEWS representative when asked whether he believed the exhibitors should have an organization.

Mr. Finnegan is vice-president for Texas of the National Motion Picture Exhibitors' League, and it was natural to suppose he would favor an organization. That he would be so enthusiastic over organization, however, was not expected.

"Why shouldn't the exhibitors be organized?" asked Mr. Finnegan. "Every other line of business that amounts to anything at all is organized. The motion picture business has reached big

proportions now and is still growing by leaps and bounds.

Exhibitors Must Show Interest

"I cannot suggest any plan to better the organization than is now in effect if the exhibitors would only take more interest in the organization. Here, in Texas, for instance, there are over five hundred exhibitors with only one hundred twenty-five members of the state exhibitors' league.

"I believe that the present organization is doing and has already done much good. The plan of having a state president for each league is a good one in my opinion, and I think that each state should have representation in the national convention based on the number of members of each state league. Say, allow one delegate for each ten membership or some other equitable figure.

"Beside being a protection to the exhibitors, the organization would also prove beneficial. Through organization the exhibitors could do much towards eliminating radical censorship and having laws passed that are not antagonistic to the business.

"Such an organization would also be of benefit to the men who furnish us with pictures and supplies because in my opinion the absolute integrity and honesty of each man applying for membership should be established beyond doubt before he is admitted to membership. In the past there have been 'shysters' in the business who have 'stung' many supply houses.

Supply Men Should Organize

"For this reason, the supply men should help in our organization. At the Southwestern Exposition of the Moving Picture Industry to be held here in Dallas, October 25, 26 and 27, many exhibitors from Texas, Louisiana, Arkansas and Oklahoma are expected, and we anticipate a big increase in the state organizations of these four states."

Kentucky Enthusiastic Over Association

Special to THE MOTION PICTURE NEWS

Louisville, Ky., Sept. 28.

THERE is no more ardent advocate in the country of the co-operative idea embodied in the National Motion Picture Exhibitors' League than L. J. Ditmar, president of the Motion Picture Exhibitors' League of Kentucky.

When he was asked for his opinion of the national body and of the work that it had set out to do, there was no mistaking the enthusiastic interest with which he answered:

"Good? Why, of course, it's good. There is no business on earth that cannot be made better and accomplish its ends with less waste, with the proper sort of organization. Consequently, organization applies with equal force to motion pictures.

"The industry stands alone among the really big businesses of the country in one respect, and that is its quick growth.

Because of this, there was no need felt for the close co-operation demanded in other businesses.

Conditions Demand Organization

"Now, as the motion picture business has begun to settle down, this condition of disorganization has come to be more and more keenly felt, and the demand of an organization that would serve as a clearing house for ideas and methods has sprung up. I believe the national league can best serve this demand.

"The present organization and basis of representation in the national body is, to my idea, satisfactory. The great need at this time is a greater interest among the large body of exhibitors.

"To secure an increased interest among the great body of exhibitors is, I believe, the biggest task facing both the national league and the various state branches. There is, and of course there will continue to be, differences of opinion as to the best method for securing this interest, but I believe the employment of organizers and personal work on the part of those already in the organizations will prove to be most effective.

Personal Solicitation Needed

"I am sure that to secure the best results, the personal touch is best, and I am sure that one organizer can do more through his personality to impress a man, not a member of an organization, than can be done in any other way.

"I am, for one, satisfied with the present executive board of the national league, and if it will apply itself to the business of the organization it should continue to be satisfactory."

Arizona Realizes Necessity of Organizing

Special to THE MOTION PICTURE NEWS

Phoenix, Ariz., Sept. 28.

SOME two years ago an attempt was made to organize the state. In fact, an organization was perfected. The presidency of the same was intrusted to the hands of a man who was heavily interested in a vaudeville venture, and who was the manager of a combination house.

Inexperienced, even in this branch of the business, and possessed of no previous experience in the amusement world, he permitted the organization to die aborning.

The state is without the first thought of an organization. That there is going to grow a paramount need of such a body, no one in the business in the state doubts for a moment. But the exhibitor awaits a Moses, to lead him out of the wilderness.

Alive to Needs of Fusion

To him who attempts the organization of the state will fall a task that will make Hercules' record look like a bean sandwich at a banker's banquet.

Many of the exhibitors here in Phoenix are alive to the fact that they

must sooner or later perfect some sort of a protective league, to ward off what is a sure thing to cause them trouble. But to get to the feasible plan is another thing.

Only lately the city commission passed an ordinance constituting the city manager, the mayor and one commissioner, a censor board for the city, with powers to look over and pass upon any and all performances whether theatrical or film.

The ordinance carries with it the proviso that the body shall have the right to "enter any theatre, motion picture house or place of amusement in the city, without price," and as some wag in the council chamber remarked the night the act became a law, "Pretty soft for the boys."

There you have it. That is the first shot in the battle which is going to be waged in the business here. The exhibitor, as I have said, is a negative quantity. He is indifferent.

He gauges his chance of obtaining by the price of films per change, and the chance of another house opening. He would look with some suspicion upon a plan that would put him on a combined defense with his competitor, for he is of the kind that considers his rival an enemy.

Lack Experience

I say he, advisedly, for the state is so new that there is not as yet enough of the experienced type to be counted upon. He is going to grow wise, but just now he is in the chrysalistic state.

He is not even a unit. He must be developed, and it is going to take a hard bump or so, to plant the seed of self-protection in him.

But he needs the organization. He needs it badly, and if he can be made to see it now, before the damage is beyond repair, he is going to profit immensely.

ADLER JOINS UNIVERSAL

Bert Adler, who for five years was in the service of the Thanhouer Company, is now engaged in "special work" of an undisclosed nature for the Universal Film Manufacturing Company. Mr. Adler started as publicity manager for Thanhouer, and recently was special representative of the late Charles J. Hite. For the present he will act as company reviewer of the brands constituting the Universal program.

LOW ADMISSION DRAWS WELL

Special to THE MOTION PICTURE NEWS

Buffalo, Sept. 30.

The Happy Hour Theatre, one of the best five-cent houses on Main street, continues to do good business because of the excellent programs which Manager Henry Marsey is booking.

Mr. Marsey is showing many of the better class of two and three-reel subjects at the low admission price.

THE EXCHANGE AND THE MANUFACTURER

By Albert C. Sproul

THERE was another phase of the proposition that Jensen developed co-ordinately with the campaign of the exhibitors—his relations with the producer.

The exchange is unquestionably an important link between the manufacturer and the exhibitor and is essential for the perfect plotting of the territory.

The advent of the parcel post and the indifference of the managers of the various exchanges pointed to new methods of distribution that were bound to be developed. The wide-awake exhibitor was clamoring for fair play, and Jensen, with his ear to the ground, heard the premonitory warning.

He felt that he not only had to justify his existence as the manager of an exchange, but was forced to intrench himself firmly, if he wished to remain in the business.

We have already pointed out the course he pursued with the exhibitors; how he had done a tremendous amount of pioneer work, in order to establish himself firmly.

It was just as essential to co-operate with the manufacturers and prove that he was well-nigh indispensable to them.

MOST exchanges are on a dead level of mediocrity, run by rule-of-thumb methods, with destinies guided by manikins.

Business initiative, due regard for the interests of clients, the personal touch that means satisfaction, all are lacking.

In the general shifting and sifting that is bound to come when the industry, now in its infancy, is fully developed, the few exceptions will be lost in the multitude of non-competents, unless they take care to guard and advertise their value.

That was what Jensen purposed doing.

In the first place, he made the manufacturers respect him by *absolutely refusing to exploit fake features*. No photoplay, no matter who produced it, would be "plugged" by him.

A feature, to receive his sanction, had to be worthy of the name.

The exhibitors *learned to put absolute confidence in him*, and his word as to the value of a photoplay was more or less final.

Jensen was even more set against the "fly-by-night" producers, who crowd the market with spurious wares which they seek to unload on the credulous. Many a virulent article on the subject found its way into the columns of the weekly bulletin that went to all the exhibitors in his locality.

Jensen had had too hard work to gain the support of his clients and dignify the industry in the vicinity to destroy all by furthering such enterprises.

IN all his dealings with the manufacturers, Jensen bore in mind the fact that *the success of the exhibitor meant the success of all other factors of the industry*.

He made his suggestions with that in view, knowing that it was the purpose of every *legitimate* producer to help stimulate the public to attend the motion-picture theatres—not to unload a lot of trash at a big profit.

For that reason, Jensen was unsparing in his judgment of the posters and heralds that advertised the plays. Every piece of literature came in for its share of criticism. Jensen played the role of exhibitor par excellence and boosted only those methods which he deemed worthy.

In this manner, he performed a two-fold service.

He protected the exhibitor from lessening the appeal of his house, which the motion picture manager certainly appreciated.

The Third Chapter of "How An Exchange Man Won His Exhibitors"—"Features that are features" was Jensen's demand on the producers; fakes were thrown back—When he found a film poor, a poster bad, a herald ugly, he told headquarters so in plain English—New theatres he advocated, and fought censors and reformers for his exhibitors with unflagging zeal.

He helped the manufacturer realize a higher ideal. Having the proper perspective in both cases, he was able to do this.

Jensen proved, moreover, a good barometer of business conditions. Unlike other managers of exchanges, he was constantly in close touch with the exhibitors and could sense the needs of the community.

He wrote with commendable regularity to the various manufacturers, giving his views of what the public wanted and particularly what it didn't want.

These opinions, backed by concrete examples and abundant statistics, had considerable influence with the producers, and affected the selection of plays to be released. It was a pity, so thought Jensen, that other exchange men did not have sufficient interest in the business to do the same.

THE question of censorship was an important one. Jensen felt that the responsibility of keeping local agitators pacified and warning the manufacturers of changes in the trend of public opinion belonged, to a great extent, to the exchange.

Many exhibitors, fearful of the consequences of actively combating political rings and misguided watch-and-ward societies, would be tempted to remain outwardly passive, for fear of their theatres being closed.

In such cases, Jensen assumed the initiative and took up the defense of the exhibitors who were allied with him. *He was always careful, however, to have the right on his side.*

If, at any time, he felt that antagonistic public opinion had a good foundation, he would remain quiescent. This made his efforts in behalf of the exhibitors—when he felt justified in defending them—all the more effective.

His suggestions and appeals were given far more consideration than they would otherwise have received, for those opposed to the industry felt that he was trying to be fair to both sides.

Conditions in Jensen's territory were much the same as those in any self-respecting locality. The public insisted on programs that their children could properly witness. Not that they necessarily demanded the ethical values; they merely desired plays that offended neither creed nor good taste.

The majority of the controversies originated from photoplays that were intended to teach a lesson. Although a number of them were serious in their purpose, *quite a few, nevertheless, used the moral merely as a pretext for salaciousness.*

After wallowing through two or three reels, built of disgusting scenes, a tag was tacked on at the end in the nature of a distinct anti-climax.

Jensen fought these plays shoulder to shoulder with the community. What he did take exception to, however, was the extremism of petty, narrow-minded patrons who were bound to put a wrong construction on a most innocent situation.

THEN there were the grafters, who wished to fatten on the industry and who, by political menace, sought to deprive the exhibitors of their hard-earned profits.

Jensen was especially bitter toward these. The caustic personalities that he hurled at them publicly penetrated the most calloused hides.

Jensen undertook, moreover, *to censor the films that he handled*. He did not cut anything out, for, if a play was in any way offensive, he would have nothing to do with it. Nor did he criticise the stuff, especially from a moral point of view.

What he did was to seek those absurd mistakes that are

(Continued on page 48.)

Regent to Revolutionize Pittsburgh Prices

Ten and Twenty Cents Will Be Prevailing Figure at New Clark & Rowland House—Reservation of Seats by Telephone Is Another Radical Innovation, and All Seats Will Be Sold with Reservation Coupons Attached to Tickets—Ventilating System of the House Is Admirable

Special to THE MOTION PICTURE NEWS

Pittsburgh, Sept. 30.

WITH a policy that is almost revolutionary in its character, and with prices that heretofore have never been charged hereabouts for admission to picture shows, the Regent Theater, Clark and Rowlands' new house now rapidly nearing completion in East Liberty, bids fair to become the pioneer in many respects.

The idea of adopting the reserved seat idea may have occurred to many of the film men, but none has ever had the nerve to try it out in this section of the country. And the price of ten and twenty cents is also a move which is bound to be watched with interest.

Several novel features are announced in the policy of the Regent. The prices for seats are to be ten and twenty cents, there being 616 of the former and 308 of the latter, which will be reserved with regular coupons. Three shows a day will be given, one in the afternoon and two in the evening, and the pictures will be changed Monday, Wednesday and Friday.

May Reserve Seats by Phone

Telephone reservations for seats will also be featured. As the seats for the first show in the evening are vacated, the head usher will notify the box office and these seats will then be sold for the second performance. In this way any one buying a reserved seat will be assured of getting a seat immediately upon entering the theater.

The Regent has its entrance upon the north side of Penn avenue, three doors west of Highland avenue. The Penn avenue entrance is twenty-three feet wide, and is erected of cream-colored ornamental terra-cotta with vari-colored decorations and the front is also twenty-three feet high, with art brass and bronze grilles and gratings.

The lobby extends back seventy-five feet to the main building, which extends 109 feet on Kirkwood street and sixty-two feet on Whitfield street. The entrance lobby is decorated in Faience tile in Italian design.

The Regent Theatre is absolutely fireproof, being built entirely of steel and concrete, only the floor and seat arms being of wood. The 924 seats are all on the ground floor, and the 308 additional seats are on the "bleacher" form at the rear of the main auditorium.

These "bleacher" seats are to be reserved. The seats on the main floor of the house will rise gradually towards the rear, and as there are no posts or gallery, every seat will have an unobstructed view of the stage or screen.

It is thirty feet from the floor to the ceiling of the Regent.

The Ventilating System

Under all the seats are inlet tubes, 400 in all. The fresh air is drawn into the air chamber in the cellar and carried to the top of the auditorium and distributed. In summer the air will be cooled with a special refrigerating device before being pumped into the auditorium. There are also two large ventilators in the roof. The floor duct tubes act as outlets in the winter and inlets in the summer.

There will be no stage in the Regent. A new screen specially constructed for the theater occupies the proscenium arch. This screen is twenty feet high and twenty-three feet wide, and is located ninety feet from the projection machines, of which there will be three, located in the operator's gallery, which is entirely separated from the main body of the house. This gallery extends the entire width of the house, is large and roomy, and gives plenty of room for the two operators required by law.

The music will be furnished by both an orchestra and a large pipe organ, the latter being designed by the Moller Pipe Organ Company. It is to be one of the finest instruments ever turned

out by that company, and is sure to furnish a brand of music that will be of a high character.

Can Empty Theatre in One Minute

The theater, facing, as it does, on three streets, can be emptied of its full capacity in one minute. There are two fire escapes, one leading from the top of the bleacher seats and the other from the operator's gallery. The lighting in the foyer and lobby will be of the semi-indirect type and there will be ten ceiling chandeliers as well as numerous brackets. A stationary vacuum cleaning system is also being installed.

The comfort of the Regent patrons is also being looked after. There are large retiring rooms for the ladies and gentlemen leading from the foyer in the back of the auditorium. There will also be an ice-water fountain and the chairs in the theatre are of the upholstered opera type.

Messrs. J. B. Clark and Richard A. Rowland are the owners of the Regent. These gentlemen are interested in eleven other theatres in Greater Pittsburgh, besides controlling the Famous Players Film Service, Inc., of this city. The architect is Harry B. Sair and the general contractors are Golden and Crick. The theater proper cost over \$75,000 complete. G. L. McCoy, Jr.

Dallas Exchange Signs for Sawyer Program

Southern Company Arranges to Handle the Service for Texas, Oklahoma, Louisiana and Arkansas Under C. R. Scott

C. R. SCOTT, of the firm of Underwood & Scott, comprising the Dallas Film Company, of Dallas, Texas, has been in New York for the past four weeks, and after thoroughly investigating the local picture field and viewing all the programs offered, he decided upon the service of Sawyer, Inc. Contracts were signed recently by which they will handle the states of Texas, Oklahoma, Louisiana and Arkansas as a Sawyer zone.

Mr. Scott is known through the Southwest as one of the pioneers in the film business of the region. For the past eight years he has handled pictures in the territory, at one time operating a chain of theatres.

These he abandoned in favor of the film exchange proposition. In Texas alone there are seven hundred theatres in operation, according to Mr. Scott, and in his whole territory covered by the Sawyer zone franchise, there are nearly fourteen hundred buying exhibitors.

"Comedies," said Mr. Scott, "are what the people want, and, to my mind, comedy does not mean films all composed of

rough and tumble slapstick business.

"We want real comedies, with original ideas, and novel treatment. This seems to be the kind that Sawyer is getting. I saw a two-reel comedy there the other day, 'Thirty Minutes in Melodrama.'

"Honestly, it is the funniest and most original thing I have seen in years. I also saw some of the reel comedies, too. His 'seven one-reel comedies a week' policy is just the thing that is wanted by the public, and such a service spells success to the houses using it.

"And that is why I wanted to handle Sawyer films in the Southwest," he concluded.

BETTIE GRAY MARRIED

Special to THE MOTION PICTURE NEWS

Lexington, Ky., Sept. 28.

Elizabeth Bettie Gray, a member of the Famous Players Company, now starring in the latest production of that company, "His Last Dollar," scenes for which are being taken here, was married September 17 to E. H. Pendleton, Jr., of Cincinnati.

LIVE WIRE EXHIBITORS

EDITOR'S NOTE.—It is the desire of "The Motion Picture News" to include under this heading novel advertising ideas, successful schemes in the management, decoration and equipment of the theatre—everything, in fact, done by the exhibitor to stimulate his trade. We invite every exhibitor to write us about any new enterprise he has; also to come to us for advice or information along any line. Address: Editor, "The Motion Picture News," 220 West Forty-second Street, New York City

VALUE OF GOOD DECORATION

ALMOST in any large city one can pick out a number of theatres that find a new owner every few months. Each one thinks he has found the means of putting it over, but as a general rule the only effort they make is to put in a new working force and sometimes apply a little paint.

The Edgewater Theatre, located on the north shore in one of Chicago's finest neighborhoods for the past few years, was one of this character. Recently, however, it was taken over by a live business man, who has made his money in merchandizing whatever he had to sell. To use his own words:

"An article before it is marketable must first be presentable, pleasing to the eye. I am putting more money into the remodeling of this theatre than it cost to first equip it. These mirrors I am placing in the panel of the doors run in money quickly.

This mahogany finish on the doors is not a cheap, shoddy imitation. I have put in a new screen and also improved on the ventilation. I am making arrangements for an organ in connection with the piano. Now it is up to me to get the people to come, and this I intend to do by advertising and delivering the goods when the people come."

The management issued a four-page booklet, and scattered copies throughout the neighborhood.

OUT GO TRADING STAMPS

AN enterprising mercantile concern in Cynthia, Ky., has abandoned trading stamps as a lure for trade and is now giving away tickets to the motion picture theatre at Roh's Opera House to all who purchase a certain amount.

"The motion picture is about the most popular institution in town," says Mr. Northcutt, of the Northcutt Mercantile Company, "and we find that this is the most attractive proposition we have been able to give our customers. And it is proving profitable both to ourselves and the picture theatre."

POLISH PATRIOTIC FILMS

DURING the recent Polish Falcons' convention in Buffalo, N. Y., the Fillmore Theatre at the corner of Fillmore and Broadway presented a number of Polish patriotic subjects.

A HABIT-MAKING THEATRE



THE HABIT THEATRE, DANVILLE, ILL.
L. G. Griffith, Manager

THE up-to-date methods of ventilation in vogue at the Habit Theatre, Danville, Ill., managed by L. G. Griffith, have earned for the little house the reputation of being the coolest place in Danville on a hot day.

The theatre seats only three hundred and fifty people, but the mere fact that the doors are open is proof that every seat inside is occupied. The Habit is

Danville's newest motion picture theatre, and is owned and operated by the Vermillion Amusement Company, Inc.

Needless to say, the name of the theatre offers Manager Griffith an endless number of opportunities for attractive advertising slogans. It is equally needless to say that none of these opportunities are overlooked by this enterprising exhibitor.

AFTER HIGH-CLASS PATRONAGE

THE management of the new Saxe Theatre, Milwaukee, the recently opened motion picture house which enjoys the reputation of being one of the most important edifices devoted to film drama in the Northwest, marking an epoch in the presentation of high class pictures in that section of the country, issued on its opening a handsome booklet in keeping with the character of the theatre itself.

The brochure, printed on a fine quality of calendered paper and bound attractively in blue mottle covers stamped with old gold letters, contains an instructive article for the part of the community which has failed to take note of the rapid advancement made in the production of motion pictures and their close rivalry with "legitimate" drama.

The theatre is fully described—its

decorations, ventilating system and means for obtaining the comfort of its patrons. In addition to this there is a list of the features scheduled for appearance at the theatre throughout the week.

A booklet of this kind cannot fail to impress the cultured members of the city and excite an interest in motion pictures as a worthy successor to the speaking stage.

THE CALL OF THE HERALD

THE Maycroft, Washington, D. C., is displaying a neat poster in artistic design which heralds: "Come in. You are in time for the entire program."

This is displayed on an easel where it may be readily read by passers-by.

"WILDFLOWER" WILL BE READY OCTOBER 15

Marguerite Clark, who attained a personal triumph in "Baby Mine," Margaret Mayo's successful play, is the latest stage celebrity to be converted to the screen, through the medium of the Famous Players four-part production, "Wildflower," to be released October 15.



MARGUERITE CLARK

"Wildflower," by Mary Germaine, is a drama of the lights and shadows of the sun-kissed forest, and the depths and shallows of human life, a delightful tale of sweet innocence and eternal youth, admirably exemplified in the personality and mannerisms of the winsome little actress.

There are many tender passages in the production, many humorous touches, and some tinged with the little sadnesses that creep into any true story of life. But Wildflower sheds her fragrance throughout the four reels of the subject, a thing of beauty always and always a symbol of purity.

Marguerite Clark's first film characterization is a notable one, and entitles the enchanting little star to be considered an important acquisition to the screen. She is supported by an adequate and capable cast, including Harold Lockwood, James Cooley, E. L. Davenport, and Jack Pickford.

EXCHANGE MAN GOES TO MUTUAL

C. E. Jones, formerly with the General Film Company, Omaha, has taken charge of the machine and machine supply department of the Mutual exchange there. The exchange will open an extensive display and sales department for machines immediately.

Mr. Jones has been in that territory for three years and has a wide acquaintance. His success in his new position is easily forecasted from the admirable record he leaves behind him.

Four New Theatres Open in Harrisburg

Exhibitors Believe That the City Has Greatest Number for Its Size—Pennsylvania's Capital Now Has Sixteen Photoplay Houses

Special to THE MOTION PICTURE NEWS

Harrisburg, Pa., Sept. 30,

THE opening of four brand new theatres, all exclusively for the display of motion pictures, has been witnessed in this city in September, and exhibitors here believe that there is no city in the country, in proportion to population, that shows so large a percentage in the number of motion picture houses built and put into operation in the present year.

Harrisburg's population is estimated at 80,000 and it now has sixteen picture theatres of a class whose seating capacity will average about eight hundred.

The fall's crop of new theatres will include another one to be opened in about two months on the site of the Star, operated at 410 Market street by Peter Magaro. The Star seated about six hundred, but the new house to take its place will seat one thousand and will be absolutely modern in its appointments.

All four of the new theatres that have been opened this month are brick structures built in the strictest conformity with the rigid requirements of the State Department of Labor & Industry that recently announced its list of "recommendations" for the construction of new picture houses, which "recommendations" are regarded by the trade as practically mandatory.

All four are situated outside the central business district, or in the five-cent zone, although it would not be surprising if at an early date these houses would unite with the downtown theatres in making a uniform admittance price of ten cents.

The largest of the new theatres is that of J. M. Lenney. It is the Grand, at Fourteenth and Derry streets, and makes the second theatre in this city controlled by this exhibitor. This is the theatre in which Mr. Lenney has introduced his theory that it is far safer and far more convenient to have the screen at the front of the building, above the main entrance, and the ease with which he has handled the crowds since opening his house seems to bear out his belief that this plan is a great improvement over that of having the screen at the rear. The house seats about 1,200 persons.

Bender Brothers have opened the William Penn, seating about nine hundred persons, at Thirteenth and Thompson streets. This is a finely equipped building designed to appeal especially to neighborhood patronage, rather than to transients. It is the first venture of the proprietors in the motion picture business and they are enthusiastic over its prospects for success.

The National, with a seating capacity of one thousand, has been opened at Sixth and Dauphin streets by Isaac Marcus, who has for several years been

conducting successfully the Royal at 55 North Third street. This new house is a long way from the center of the city and in a section containing the homes of railroad men and their families. Harrisburg is a very strong railroad center and Mr. Marcus will cater especially to that class of motion picture patrons.

A new theatre opened at Third and Harris streets by C. E. Hanshaw, a newcomer in the business, has a seating capacity of one thousand. Like all of the other new ones, it is a brick and concrete structure, fireproof in every respect, and equipped with all the latest devices for safety and comfort.

V. H. BERGHAUS.

TROLLEY WRECKED FOR "A PRINCE OF INDIA"

In a four-part drama made by Wharton, Inc., and released by the Electric Film Company, a startling series of events lead up to the sensational climax of a bona fide trolley car leaving the rails on a high bridge and plunging a



THE TROLLEY WRECK IN "A PRINCE OF INDIA"
(Eclectic Feature)

great distance into the yawning gorge below. The four reels are full of thrills, and this climax, coming near the end as it does, will certainly not let the picture pass without comment.

The illustration gives one a vivid sense of the "accident" which the company has staged for a feature.

Directory of New Theatres

EDITOR'S NOTE.—The information contained in the "Directory of New Theatres" is gathered by the field representatives of "The Motion Picture News" and the facts and figures in each instance have been verified by them and are authentic. They may be relied upon by members of the trade.

REGENT OPENS IN BUFFALO

BEFORE a large and enthusiastic audience of local exhibitors, exchange men and friends of the owners, the beautiful new Regent theatre, Buffalo, N. Y., opened with a special performance on Saturday evening, September 26. The opening to the public was on Sunday afternoon.

The Regent is operated by the United Motion Picture Theatres, Ltd., of which Henry J. Brock is general manager. The house is under the management of Arthur C. Willats, well known in Buffalo amusement circles. The opening attraction was "The Battle of the Sexes," supplemented by "The War of Wars."

The Regent is the first theatre in Buffalo with a seating capacity of less than 1,500 to charge an admission price of fifteen cents for seats other than boxes. The prices will be 10-15-25, the latter for boxes, which are arranged at the back of the theatre.

The seating capacity of the Regent is 1,300, all on one floor. The entrance is on Main street, a few doors from Utica. The front is of white terra cotta, which presents a most beautiful appearance in the daytime, or at night when the brilliant lights are turned on. The lobby is decorated in old gold, imperial purple and Byzantium gold. The foyer is a vision of scintillating gorgeousness.

Rich carpets cover the floor, their rich colors blending perfectly with the rich wall and panel decorations. Although the foyer reaches across the full width of the playhouse, the soft tones from the indirect lighting system and side decorations tend to bring the great space into a cozy ensemble.

Elaborate Stage Setting

The stage is elaborately set. In the immediate foreground is a bright green garden which surrounds a playing fountain, fantastically illuminated. Set far back is the screen, which is covered by curtains of purple velvet, during the music program. The indirect lighting system fixtures are the most beautiful in any theatre in Buffalo. The office of Mr. Willats is at the right of the operator's booth, in a sort of balcony at the rear of the theatre.

One of the real treats at the Regent theatre will be the music programs, for Mr. Henry M. Marcus, formerly direc-

tor of Shea's theatre orchestra and one of Buffalo's most accomplished musicians, is director of the orchestra. The program on opening night was enthusiastically applauded. A large pipe organ has been installed to supplement the orchestra numbers.



THE REGENT THEATRE, BUFFALO, N. Y.

The Regent is a theatre that is "different" in every way. Everywhere you look one finds a restful and artistic object. The ushers are clad in beautiful uniforms, tastily trimmed in gold. The orchestra members wear full dress at all performances.

The Regent's Policy

In speaking of the Regent's policy, Mr. Willats said:

"We shall endeavor to present at all times the finest and cleanest productions of the film realm; to surround our patrons with an atmosphere of culture and refinement, offering only such entertainment that will be consistent with the dignity of American manhood, and to treat all with such courtesy and respect as to insure appreciation of our audiences.

"We shall cater to the children, endeavoring to conserve their purity of thought above all other things. No questionable subject shall ever creep into our programs. All films will be screened before being shown to the public and all objectionable parts eliminated.

"We recognize that we have a duty to perform to our patrons and to ourselves, to see that our programs are the kind required by intelligent and honest audiences, consequently the greatest care will be given to the selection of films.

Catering to Children

"Photoplays which may hold the keen interest of the adult are often a little too deep for the ordinary child; we have therefore mapped out a plan for their especial benefit: our Saturday matinees will be devoted to children, and will be entirely different from the regular program.

"It will consist of such helpful subjects as 'Safety First,' 'Spotless Town,' besides dealing with 'Diseases by Flies,' 'Nature Subjects' and 'Scenes and Travels.' Not one feature will be shown at Saturday matinees. Of course there will be comedies, without which a series of pictures would be a hardship on the child mind.

"Performances will be given every evening from 7:30 to 10:30. Saturday children's matinee from 2 to 5. Sundays, continuous from 2 until 10:30. Box seats when ordered in advance will be ten cents extra. The program will be changed four times weekly, Monday, Thursday, Sunday and Saturday matinee."

The policy of running films for scrutiny by the management indicates a desire to exercise close supervision over the pictures.

A description of the Regent without special mention of the work of the decorators would be incomplete. The entire decorative scheme was worked out by Edward J. Murnane, of Chicago, New York and Syracuse. There is something about the Murnane decorations that is particularly appealing. The uniqueness of design, the richness of color schemes and artistic workmanship produce effects that are both artistic and enchanting.

NEW YORK MAN TAKES LEASE OF WATERBURY THEATRE

GEORGE H. BEARDSLEY, of New York, has leased the Colonial Theatre on South Main street, Waterbury, Conn. John J. Sheehan had been conducting the house since it was dedicated to the silent drama.

Mr. Beardsley for the past six months

has been "covering" the state of Connecticut for the Atsco Company, now the Alco Film Corporation, making sales for the Radium Gold Fibre screens and other of the company's "findings."

The new manager of the Colonial is not new at the game of "running" a house. He has been identified with sev-



THE COLONIAL THEATRE, WATERBURY, CONN.

eral theatres within the past six years. Mr. Beardsley is well known in New York City and Brooklyn, and his many friends there will be glad to learn of his latest venture.

The Colonial is an up-to-date theatre. It seats four hundred in the gallery and orchestra, has two Power's 6A machines and a comfortable "foyer."

Mr. Beardsley in making his announcement said that the house's object was the patrons' pleasure, and that it was to be second to none in the city.

Within a week or two Mr. Beardsley will exhibit all of the latest features at his theatre. He has made slight alterations in the house and is confident of success being meted out to him.

ASBURY PARK HOUSE CHANGES HANDS

D. R. ZACHARIAS, the automobile and garage man, made his debut in Asbury Park, N. J., as a theatre promoter recently when he took over the World in Motion, Cookman avenue and Kingsley street. This enterprise is merely a preliminary to the introduction of an elaborate fireproof photoplay establishment of steel and concrete at Munroe avenue and the railroad, which Mr. Zacharias proposes to throw open to the public early in November.

New Eaco Film Company Has Many Releases

The Concern, Headed by Edwin August and Edward Anderson, Plans to Put Out a Two-Reel Drama Every Other Week

EACO Films, the newly-formed producing company, headed by Edwin August and Edward Anderson, have now made a number of features, which will be released as soon as the firm has decided what medium to use.

When matters are well under way it is the plan of the company to release a two-reel drama every other week, and a single reel drama and comedy each week.

Mr. August, who will write and supervise the direction of all the pictures, will appear in person in the features, supported by Alice Learn, who will play opposite, and Ann Derson, an English actress will appear in the heavy roles.

A studio is soon to be erected on the west coast, where westerns will be turned out featuring Edward Peil. Hal August, formerly a Universal lead, will

appear in the comedies, which are to be of the parlor nature, not slapstick.

Mr. August will shortly journey to Bermuda to film several pictures. On his return he and the eastern company will be located at Jacksonville, Fla.

The interiors of Eaco's first picture, "Below the Dead Line," were made in the Pathé studios, which were temporarily loaned them; the exteriors were filmed in New York.

Bennie Zeidman, publicity man of the concern, formerly of "Lubinville," who is now busy creating "Eacoville," is unable to tell as yet what exchange the company will release through. Owing to the great popularity of Edwin August, many communications have been received from exhibitors, requesting them to release through their exchanges. The question will shortly be decided.

Lubin Unaffected by War Situation

Company, Instead of Curtailing Expenses, Is Spending More Money Than Ever to Supply Demand for Films, Says President

"It is rather hard to give an intelligent forecast of the coming few months in the motion picture or any other amusement business," says Siegmund Lubin.

"This senseless war has toppled all arts and industries upside down all over the world, but we are not indulging in pessimistic views, neither are we relaxing our efforts to continually achieve greater things.

"On the contrary, we are working the cameras full time and spending more money than ever in securing great scripts and talented players. This will readily be seen from the advertisements of our productions to be released in the near future.

"Money would have to be tight indeed

if it interfered with the very enjoyable and cheap recreation that the picture house affords to distract the more serious thoughts of the present unfortunate condition of the whole civilized world.

"Here peace is giving us happiness and we can enjoy our labor without let or hindrance. Still in this cosmopolitan country there are many heart strings pulling at the thought of misery now prevailing among dear ones in the mother lands.

"However, the camera is dispensing more happiness than guns and will be an institution when they are silenced, and the ships of the nations are free to come and go over the waters again to foreign lands."

World Film Gets "Seats of the Mighty"

Screen Version of Famous Parker Novel, Picturized by Colonial Corporation at Considerable Expense, Transferred to Former Concern

LEWIS J. SELZNICK, vice-president and general manager of the World Film Corporation, has captured for the World Film Corporation the photoplay to which the Colonial Motion Picture Corporation has been devoting unlimited capital and the best trained talent possible under the general supervision of T. Hayes Hunter. The transfer brings to the World Film Corporation filmization of the famous Sir Gilbert Parker novel, "Seats of the Mighty," upon which the Colonial forces have been at work for six months.

Lionel Barrymore, brother of the famous Ethel Barrymore, and a member of that famous acting family, is featured in this picture, and he has been surrounded by a first-class cast of Broad-

way stars. In the company are such names as Millicent Evans, Lois Meredith, Thomas Jefferson, Glen White, Clinton Preston, Harold Hartzell, Grace Leigh and Marjorie Bonner. All of these stars have been seen and are being seen in Broadway productions.

The negotiations were carried on behalf of the World Film Corporation by Lewis J. Selznick, while James D. Law, president of the Colonial Motion Picture Corporation, and Duff C. Law, technical director, represented the Colonial Motion Picture Corporation interests.

General Manager Selznick announces that "Seats of the Mighty" is to be a special release and the date is to be announced shortly.

FACTS FROM QUAKER CITY FILM CIRCLES

Bosworth Banquet a Complete Success—State Censor and Philadelphia Newspaper Men Gather Around Carl H. Pierce to Do Honor to the Motion Picture—Other Festivities of Similar Character Will Follow in Its Wake—Mastbaum Dinner on October 1 at Bellevue-Stratford

Special to THE MOTION PICTURE NEWS

Philadelphia, October 1.

THE banquet given by Bosworth in the name of Jack London on Wednesday, September 23, at the Hotel Adelphia, was an immense success in every respect. The dramatic critics of all the local newspapers and the local representatives of the trade journals were present.

J. Louis Breiting, chief motion picture censor of Pennsylvania, was the guest of honor, being placed at the right of Carl H. Pierce, the special representative of Bosworth, who acted as host. Mr. Breiting briefly outlined what he had done and what he hoped to do in the matter of censoring pictures in this State.

He explained that he had systematized the work of his office in order that there would be as little delay as possible to those submitting films for examination. He spoke very highly of the work of the American producers, stating that he had little or no cuts to make.

To date 3,500 reels have been examined, and of this number there have been but two reels rejected entirely and but 120 eliminations, all of a minor character.

Editor Criticises War Tax

W. Barran Lewis, city editor of the Philadelphia "Press," spoke of the advance made by the picture theater of today. He was also very outspoken regarding the proposed "war tax," and said:

"I do not see why the picture theater should have to pay as much tax as the legitimate theater. Why should a little twenty or even 500-seat house have to pay the same amount as Keith's here on Chestnut street. The little house makes maybe \$25 or \$50 profit a week. The Keith house plays to a four figure audience every week. Where is the justice in it?"

Abe L. Einstein, press representative of the Stanley Company, spoke of the value of newspaper publicity for theaters and amusement enterprises. Harry Knapp, of the "Inquirer," said that the matter of a motion picture page has been under consideration for a long time, but that it probably would not be established until the manufacturers would support it.

Julian M. Solomon, Jr., of THE MOTION PICTURE NEWS, then spoke briefly of what other newspapers had done towards and after establishing motion picture sections. The case of the Seattle "Times" and the Baltimore "News," the stories of which recently appeared in this paper, were quoted as shining examples of what could be done.

A. D. Ferris and F. V. Armato then spoke of what had been accomplished by their paper, "The Evening Telegraph." They both said that the film section had been a commercial success as well as a circulation booster. Mr. Armato had found that by catering to

ceive notice to relegate the "legit" reviews to the advertising pages along with burlesque and to place film reviews on the present dramatic page.

H. Deick, of the "Record," said that his paper has at present under consideration a picture section. This paper



SCENE AT THE BANQUET GIVEN BY BOSWORTH, INC., TO THE PRESS

Left to right: W. B. Lewis, "The Press"; Eugene L. Perry, Stanley Company; Howard Deick, "Record"; Julian M. Solomon, Jr., MOTION PICTURE NEWS; George Mann, Stanley Booking Co.; Howard Bonte, "Public Ledger"; J. Louis Breiting, Censor; Carl H. Pierce, Special Representative, Bosworth, Inc., and Host; Abe L. Einstein, Stanley Company; Harry Knapp, "Inquirer"; Steve Talbot, "Billboard"; F. V. Armato, "Evening Telegraph"; A. D. Ferris, "Evening Telegraph"; B. Diamond, "North American"; Wm. E. Smith, Famous Players Exchange.

the exhibitor rather than to the manufacturer he had been able to produce financial returns for the paper.

Other Opinions Voiced

Eugene L. Perry, general manager of the Stanley Company, spoke of the progress which the pictures had made, and of the fact that while he had handled everything from vaudeville to "legit," that he was now in the picture business to stay. George Mann, of the Stanley Booking Company, said that he was glad that there was a censor, as it saved him much trouble in booking his features, as he could be assured that there would be nothing to offend the patrons of his firm's theaters.

Howard Bonte, of the "Public Ledger," Philadelphia's most conservative paper, said that George Ochs, his managing director, had recently attended one of the high-price picture houses in this city. It was Mr. Ochs' very first time at a picture theater of any kind, and the film was a Paramount picture.

It created such a favorable impression that Mr. Bonte is expecting to re-

found that when they featured "The Adventures of Kathlyn" that the circulation of the Sunday edition was increased considerably. The effect was also felt on the daily circulation.

B. Diamond, of the "North American," thought that the day is not far distant when every newspaper will have a special section devoted to motion pictures.

State Censor Praises Paramount

Mr. Breiting had a few final words to say in praise of the work of Mr. Armato, of the "Telegraph." In closing, he said that if he had all pictures to review similar to Paramount there would be no necessity for him to retain his office.

Carl H. Pierce, as host, also acted as toastmaster, and spoke of the character of men like Frank A. Garbutt and Hobart Bosworth, who had come into the picture business with the idea of producing better pictures and who had tried, with much success, to uplift their tone and quality.

The menu cards were clever, and the

following good things were listed for the guests:

"Barleycorn" Cocktails, Cape Cod
 "Burning Daylight" Celery
 Olives au "Sea Wolf"
 "Marten Eden" Puree
 Chicken Casserole au "Valley of the Moon"
 Potatoes "Paramount"
 Hearts of Romain—"London" Dressing
 "Bosworth" Neapolitan Parfait
 Assorted Cakes "Odyssey"
 Cafe au "Phantom"
 Cigars "Smoke Believ"
 Cigarettes "Hypocrites"

Mastbaum Plans Banquet

Stanley Mastbaum, one of the invited guests, was called away on business at the last moment, but was so impressed with the good work that it would undoubtedly produce that he invited all those who attended this one and in addition many film manufacturers to be his guests at another banquet.

Mr. Mastbaum's spread takes place at the Bellview-Stratford, in the Red Room, tonight. In addition to the newspaper and tradepaper guests, there will be representatives from Famous Players, General Film, Lubin, Universal and Mutual. Adolph Zukor is expected to be present.

It is intended to make this affair a regular monthly institution, so that the newspaper and film men may foregather and swap ideas for the benefit of all concerned.

"THE POWERS THAT BE"

The Paramount Film Corporation of Philadelphia, Pa., have purchased a Power's Cameragraph No. 6A motion picture projecting machine, through L. M. Swaab, of that city.

The United States battleship "Utah" has installed a Power's Cameragraph No. 6A motion picture projecting machine.

The Young Men's Christian Association of New Haven, Conn., have purchased and installed a Power's Cameragraph No. 6A motion picture projecting machine.

The Adirondack Electric Power Company, Amsterdam, N. Y., purchased two Power's Cameragraph No. 6A motion picture projecting machines, through the Picture Theatre Equipment Company of New York City.

The New York Parental School, Flushing, N. Y., have installed a Power's Cameragraph No. 6A motion picture projecting machine. This machine was purchased through The Picture Theatre Equipment Company of New York City.

The Lathorp Coal Company, of Panther, W. Va., have purchased a Power's Cameragraph No. 6A motion picture projecting machine through Williams, Brown & Earle, of Philadelphia, Pa.

The New York Eastern Reformatory at Napanock, N. Y., have purchased a Power's Cameragraph No. 6A motion picture projecting machine through The Picture Theatre Equipment Company, of New York City.

These are only a few of recent installations of Power's machines.

Hepworth Films Go Through Blinkhorn

Will Handle Their Releases in America, According to Negotiations Concluded with Director Parfrey, of the London House

THE Hepworth Company, of London, it will be remembered, was the first English firm to have their own company in America to handle their film and look after their interest generally. During

the matter he is said to have successfully negotiated a satisfactory arrangement with Mr. Blinkhorn, who has formed the Blinkhorn Photoplays Corporation with himself as president, whereby the latter corporation have agreed to take a large proportion of Hepworth, Florence Turner and Ivy Close releases for this country.

The Hepworth Company will still continue to sell on the option market and are releasing their regular output in spite of the European disturbance.



ALBERT BLINKHORN

Albert Blinkhorn's recent trip to London, when he had an interview with the directors of the Hepworth Company, he explained to them his views with reference to the renting business in America. At the same time he handed in his resignation as president of their American company, as he had in view the formation of another corporation which was to be devoted to renting only with a chain of offices in the United States.

Following this the Hepworth Company held a directors' meeting, when Mr. Blinkhorn made them a proposition for handling their product in America and they decided to send one of their representatives to New York for the purpose of making inquiries.

With this end in view Mr. C. Parfrey, one of the directors, came to this country some weeks ago and after going into



C. PARFREY

Dissatisfaction with many of the methods in vogue among state-right buyers led him to enter the exchange field, Mr. Blinkhorn recently declared. One practice which was peculiarly distasteful to him was the state-right buyer's habit, in many cases, of going outside the limits of his own territory to sell his film.

John Wild will be associated with the Blinkhorn company in a managerial capacity.

Woods Suggests Cut-Out Sign for Public

Special to THE MOTION PICTURE NEWS

Los Angeles, Sept. 28.

A SUGGESTION for film manufacturers has been made by Frank E. Woods, scenario editor and general manager of the Majestic Motion Picture company studio at Hollywood, which if followed would place the blame for imperfect continuity of pictures severely censored upon the censor boards, thus shifting it from the manufacturers.

The suggestion is that manufacturers supply each of their exchanges with pieces of film bearing the following

words, tersely explaining the situation:

SECTION OF FILM REMOVED
 by Order of
BOARD OF CENSORS

which could be placed in the pictures where a cut-out of a portion of a scene or a sub-title is ordered, and thus give the public to understand that the picture has been altered. If it is impossible for them to follow the story they will place the blame, Mr. Woods believes, where it justly belongs.

J. C. JESSEN.

Chicago Censors Make Wholesale Onslaught

Board Refuses to Pass Six Pictures in One Week and Cuts Seventy-three Others—List of Objections Grows Since Funkhouser Increased Membership—Electrical Workers' Union Seek Recognition—Exhibitors Sell Novel, Basis of Kleine Feature, During Intermissions

Special to THE MOTION PICTURE NEWS

Chicago, Sept. 30.

In one week Chicago's board of censors killed six subjects and cut seventy-three pictures. The pictures killed range anywhere from one reel to five reel subjects, while those that were slashed had many scenes and titles taken out of each.

This was not an extraordinary busy week for Funkhouser's board, but merely an ordinary six days' work. Some weeks undoubtedly would average greater.

This board has four points to which it objects, namely: crime, degradation of women, making heroes of criminals and ridiculing constituted authority.

These are the points they claim are censored, but the list of cut-outs show that "The Master of the World," a Film Releases of America picture, was slashed throughout the scene showing snakes; the same also was done to "Sarah the Pythoness," a Lubin, where they had to shorten three snake scenes to a flash and eliminate four other scenes. Pathe's "The Thousand Dollar Pants" was compelled to eliminate a scene showing a tramp with a torn seat in his trousers.

Fashion, in Objection to Films

Perhaps Funkhouser's list of objections has grown larger since he increased his board. It appears as though each one has some pet objection. Some little time ago they had the religious bug; now they do not like snakes. Perhaps they'll add another new member with another objection soon.

For the past few weeks the differences between the two local operators' unions have been asserting themselves. The International Brotherhood of Electrical Workers and the Motion Picture Operators' Union, Local No. 2, are the names of the organizations in the field seeking recognition.

Local No. 2 has been in the field for some time and at present is affiliated with the Stage Hands Union, which in turn is affiliated with the American Federation of Labor. The International Brotherhood of Electrical Workers, however, claim to have a direct charter under which they are operating.

A few of the motion picture theatres have been annoyed, it is claimed, by the International Brotherhood of Electrical Workers. The Biograph and Vitagraph theatres were recently the victims of odoriferous bombs which, they claim, were thrown by members of the electrical workers.

Other managers in the city claim they have been threatened by this organization if they did not install a member of their union.

The old union feels secure in its stand and is not giving the present trouble any recognition. The electrical workers are fighting for membership and recognition. It is their claim that many are joining them from the ranks of the other organization.

Electrical Union Seeks Recognition

It seems that this rival union was formed because of the many operators who were working in theatres on a card system issued by the old union, and at no time was any effort made to admit them as full fledged members. It is said this card cost them a dollar a week, whereas the yearly dues would have been much less.

This is the second time in the history of the operators' union that there has been dissension. The last time the union was dissolved and organized again and now stands as Local No. 2.

With the last few weeks three new exchanges have been opened in Chicago. Each one is a branch of a parent organization the headquarters of which is in New York City. The Alco, Box Office Attractions and Blinkhorn Features are the three acquisitions to the exchange ranks. All three are in the Mallers building, and all three are on the fifth floor.

Get Ready for Big Business

The Box Office Attractions is managed by Mr. Montgomery, formerly with the local General Film Company exchange. The Alco offices are in charge of Mr. Leist, who up until his present association was with the Famous Players office. The Blinkhorn pictures are under the direction of Mr. Buck, who hails from the East.

Felix Feist, general manager of the Celebrated Players Film Company, of Chicago, went East recently for the purpose of arranging with some releasing company for the handling of their output in the Central West.

Under Mr. Feist's management the Celebrated company has prospered. He has infused his personality into the entire organization.

About the first of November, John W. Root expects to open his new one thousand seat house in Pasadena, Cal., which will be named the Strand. Mr. Root formerly owned a theatre in Burlington, Ia., and one in Altoona, Ia. He recently spent a few days in Chicago purchasing equipment from the Kleine Optical Company for his new house.

Enthusiastic Over Kleine Film

George Kleine's big new six-part subject, "The Lion of Venice," has come in for a unique compliment. The Chicago Board of Censors, which viewed

the print for the purpose of issuing a permit, were so delighted with the film that its members insisted upon being notified of its first public exhibition in Chicago.

Accordingly, they brought relatives and friends to the Hamlin Theatre, Madison street and Hamlin avenue, when the Kleine subject was officially launched in Chicago. The censorship board runs film continuously from nine in the morning until five at night and are pretty well satisfied at the end of the day.

George Kleine announces that his various branch offices are now ready to book "The Naked Truth," that splendid five-part modern drama which opened the doors of the New Candler Theatre last summer.

The film features Lyda Borelli, the famous Continental actress who proved such a sensation in Italy recently in an Italian version of Fannie Ward's "Madam President." "The Naked Truth" has been provided with an exceptionally clever line of advertising matter.

Sell "Vendetta" in Intermissions

George Kleine's "Vendetta," which is now booking through the special feature department of the General Film Company, is being advertised heavily by exhibitors throughout America.

The novel, by Marie Corelli, has been translated into the German, French, Russian, Greek, Italian, Persian and Hindustani. Wideawake exhibitors have prevailed upon local bookstores to put in a supply of the novel and allow them to use the valuable window space for a three and six sheet. In some cases, exhibitors have laid in a stock of the paper-covered volumes which they sell in the intermission and in front of the theatre.

President S. S. Hutchinson, of the American Film Manufacturing Company, with his wife and two sons, Hobart and Winston, returned on the Olympic, Wednesday, September 23.

Mr. Hutchinson's experiences abroad were of a somewhat thrilling nature and the sight of American soil caused a thrill of joy such as can be appreciated only by those who, after weeks of harassing trials and tribulations, again come into their own rightful heritage.

"Mr. Hutchinson left London for a business and pleasure trip to the Continent," says the Kinematograph and Lantern Weekly of London. "He was in Switzerland when the outbreak of war was announced, and only succeeded in reaching London again, after a journey through France which occupied in all six days and which gave him a re-

(Continued on page 50.)

In and Out of Los Angeles Studios

Special to THE MOTION PICTURE NEWS

Los Angeles, Sept. 28.

RELUCTANTLY members of the Jacques Jaccard Universal Producing Company last week began the filming of "The Terrance O'Rourke, Soldier of Fortune," series, from the stories by Louis Joseph Vance.

When arrangements were made with the author for the use of these stories it was announced the producing company would make a tour of the world in filming the fourteen series of pictures of two and three reels each, but because of the European war this trip has been abandoned. All of the series will be made in California.

The first number will be released under the title of "His Heart, His Hand, and His Sword," and will consist of three reels. This has to do with O'Rourke meeting Princess Grandlieu, and the planning of the rescue party to go to the Sahara desert to save the life of the princess' brother and prevent her husband from gaining control of the family's wealth.

The story has been rewritten from the book by Mr. Vance, and many additional incidents have been added which materially increase its value for motion pictures.

Story Based on Chemical Fire

The producing company, in addition to Director Jaccard and J. Warren Kerrigan, who plays the name role, is composed of Vera Sisson, George Perolat, M. B. Robbins, Ray Gallagher, Louis Kassa, Edgar Lowery, Harry Gant, Bud Chase and Pedro Leon.

Western comedy was made last week by Allen Curtis, in the one reeler, "I'll Be Dawg-gonned." Two cowboys, William Franey and Sam Kauffman, with six months' salary burning holes in their pockets, go to a Western town to cut some capers, and both fall desperately in love with Widow Clemon (Gale Henry), who, with the aid of Attorney Hearse (Jack Leonard), succeed in getting the roll of long green.

Calder Johnstone, of the Universal scenario department, has written a story based on a big fire in a chemical house in New York several years ago, in which an air bubble in a window caused the sun to set fire to the chemicals.

However, in the scenario for "The Star Gazer," a big telescope used by one character on the streets where the public may look over the heavens for five cents per, causes a fire at the home

of the heroine of the store when she was polishing the furniture with kerosene, preparing for her wedding with a newspaper reporter.

Insurance men find the oil-soaked rag and refuse insurance, but the newspaper pussy-foot discovers the real cause



J. WARREN KERRIGAN

of the fire—the telescope—and brings happiness to the household. Murdock McQuarrie is cast for the star gazer, Agnes Vernon for the daughter, and M. K. Wilson for the reporter. Charles Giblyn will direct the picture.

Plays with Dislocated Ribs

Number eleven of "The Trey o'Hearts" series of the Universal proved the unlucky one for the hero, George Larkin, playing the role of Alan Law, and he is now doing his part while wearing a number of braces and plasters, needed because several ribs were dislocated when he jumped from a second story window to a horse's back just as the animal reared into the air.

This prevented Mr. Larkin from working for two or three days, but he is now in the midst of a very sensational

chase across the desert, for series number twelve. In this a trick horse takes the glories of the picture away from the human actors, by performing stunts to save the lives of the photoplayers, during a sand storm on the desert.

When a posse of citizens close in on the leads, whom they think are responsible for a murder, a large quantity of dynamite is exploded, causing the formation of a barrier, and permitting the party to continue in an automobile. This number will undoubtedly be the most spectacular of the series yet produced.

In "Marvis of the Glen," from a scenario by Mary Murillo, now being produced by Robert Z. Leonard, Ella Hall is playing the name part in a story portraying a man of wealth becoming infatuated and marrying a little beauty of the wilds.

This causes a breach between him and his sister, and the husband is lured away in order that he forget his unsophisticated bride. But when he returns he finds her the belle of the city, and after numerous complications, the couple are re-united. Mr. Leonard is playing the male lead.

Sensational Lion Scene

The two months old lion cubs of the Universal zoo made their debut last week in films, in a picture directed by Henry McRea, for the 101 Bison release, under the title of "Taming the Wild."

Scenes for the picture are laid at a hunters' camp, where a party employed by a circus to capture wild beasts, arrive. The hunter, a white man, falls in love with a young woman of the party, and when she refuses his hand in marriage, and at a time he knows she is playing with a cub lion from his menagerie, turns the mother lion loose.

The picture will contain some very sensational scenes. Rex de Roselli is playing lead, Val Paul, heavy, William Clifford character lead; Lule Warrenton, female character, and Marie Walcamp, lead.

Intent upon kidnapping his sweetheart, the hero of Jack Blystone's latest one-reel comedy, "His Night Out," gets into the wrong rooms, and after carrying father, mother and a negro maid out, thinking it the "dear little one," he then decided to take the minister to the girl and there fight out the difficulties with the father of the girl. The cast is made up of Ernest Shields, Betty Shade, Phil Dunham and Eddie Boland.

By the aid of some excellent photographic work, a very interesting trick picture has been made by Charles Giblyn and company. In this, father pulls his chair to the fire to look through the family album, and as he turns each leaf a close-up view of the page first shows the photograph, and then, after a fade-out, the principal incident in the life of the person is enacted on the page in the place of the photograph.

The part of father is played by Murdoch MacQuarrie; mother, Beatrice Van; son, Millard K. Wilson, and daughter, Agnes Vernon. The scenario is by James Dayton, and the picture will be released under the title, "As We Journey Through Life."

Films the Angel's Flight

One of the sure laugh makers of the Nestor releases will be "The Angel's Flight," filmed last week by Al E. Curtis and company, composed of Eddie Lyons, Victoria Ford and Lee Moran. The picture will be filmed at Angel Flight, a name given to the stairs up Third street from Hill street to the top of Bunker Hill, about ninety feet above the level of the retail district of Los Angeles.

At each place there are pairs of cars operated on extremely narrow gauge tracks, and so arranged that one car goes up and the other down at the same time, thus greatly reducing the power necessary. The big feature of the picture will be the portrayal of the ups and downs of an irritated husband trying to catch his wife.

Angel Flight is one of the wonders of Los Angeles, and from the top of the hill—which is the highest spot in Los Angeles—a wonderful view of the city can be made.

"Star of the Sea" Shipped East

"Star of the Sea," a three-reel drama, featuring Pauline Bush, produced by Director Joseph de Grasse, at the Universal studio, during the past few weeks, is now finished, and was shown to the photoplayers before being shipped to the New York office of the company.

The scenario for this picture was written in February and production was delayed because so many unusual props and settings were necessary. This is a story of a young Paris sculptor who falls in love with the widowed daughter of a fisherman, who poses as his model in the making of the Madonna.

The six months old child used in scores of scenes comes near stealing the honors of the production. The principals of the cast beside Miss Bush are Laura Oakley, Howard Fenton, Lon Chaney and William Dowlan.

"The Chorus Girl's Thanksgiving," featuring Anna Little, was produced last week by the Frank Lloyd Gold Seal Company, at the Universay studio. It is a story of an unfortunate young man who betrays and robs his employer in order to pay a doctor's bill caused by the illness of his mother.

Finding himself trapped in a room

occupied by a poor chorus girl, he forces a gun into her hand and thereby secures a thousand dollars' reward for her by his capture. Herbert Rawlinson takes the part of the criminal, and William Worthington plays the character lead.

"Rose of the Rancho" Under Way

Work at the Lasky studios is progressing on several of the Belasco plays, first of which will be "The Rose of the Rancho," in which Bessie Barriscale and Theodore Roberts will handle the principal roles.

Cecil B. De Mille and a company of twenty-one players, journeyed to Old Monterey, California, last week, where the Lasky executive staff had arranged for the temporary use of the ancient Spanish Custom House and a famous land mark, The Padre's Garden, which is a typical and reminiscent remembrance of the Latin Period of the Pacific Coast.

In addition to the two places mentioned, Mr. De Mille has obtained permission from the managers of the estate for the use, for the making of the pictures, of the entire enormous Castro Rancho grounds, comprising many acres of wonderful historic grounds and containing the fast-crumbling remains of one of the oldest missions in California.

The Lasky company also leased a five hundred acre tract of land from the United States government which gives them, also the right to the densely wooded tract of over two thousand acres and which contains several magnificent scenic spots. The tract is at the foot of the San Fernando mountains, twenty-one miles from the studio at Hollywood. There are over a million dol-

lars' worth of historic properties on the tract which the Lasky concern are bonded to protect.

Political Setting for Majestic Release

"On the Wings of Love" is a political story being produced by William Christy Cabanne, for Majestic-Mutual release, and one of the big scenes for this is a race between a hydroplane and a motorboat on the Pacific Ocean, which ends with the hero gripping a rope and being carried away from the boat by the speedier craft. The scenario is by Russell E. Smith.

The bank clerk who is in need of money with which to pay the expenses of caring for an invalid daughter, is the first of the plot of the scenario for "The Availing Prayer," being produced under the direction of Donald Crisp, for the Reliance-Mutual release.

Just when the aged clerk is going to steal the money from the bank, he finds other burglars there, and is handsomely awarded by his employers for saving the bank from loss. R. A. Walsh and Spottiswoode Aitken are assigned leading parts in this picture.

A problem play having to do with the low salaries of employees of department stores, is being produced by Jack O'Brien, as a Majestic-Mutual release. The scenario is by Anita Loos, of San Diego, and in the story the daughter of the store owner disguises herself as a poor girl in order to learn true conditions.

In the end she induces her father to raise the wage scale, saves him from being killed by a dissatisfied workman, and brings a pretty romance to a happy ending. Among the members of the cast for this picture are Blanche Sweet.

(Continued on page 73.)



KEARNEY AND GEORGE ARE CAPTURED BY VAQUEROS
Scene from "The Rose of the Rancho"—Lasky-Paramount Feature

Manchester's \$10,000,000 Film Vision Vanishes

His Grace Abandons World Pictures Idea—Dr. Carter's Company, Organized for Handling Educational and Religious Subjects, Unaffected by Failure—One Contract of the Duke Involved \$702,000 Worth of Projection Machines—Also Ordered \$18,000 Prints of Six Reel Features

THE film trade has seen another large and brilliant scheme go by the board in the past week in the shape of a \$10,000,000 concern which was expected to supply educational motion pictures to the world at large.

This organization, the Duke of Manchester's International Education League, has expired under a cloud. And, although men who have been in the scheme have said that the cessation of activities was only temporary, there is good reason to believe that there will be no revival—at least under ducal auspices.

The duke, himself, has not been in New York except for a few hours in about two weeks, and there are strong probabilities that he will sail for Europe shortly, if he has not done so already.

The scheme which was headed by the duke was one of world-wide significance. It included the filming of an unlimited number of religious and educational subjects all over the globe and the ramifications were to have been numberless.

Plan Considered Visionary

The plan appears to have been extremely visionary on the part of Manchester, but he got others to take an interest in it, despite the fact that to a great many motion picture men, at least, it seemed highly impracticable.

One of those so interested was Dr. William Carter, who had so far organized a similar company as to have the incorporation papers ready for filing at Albany. Dr. Carter was approached by the duke and an arrangement was made whereby the two men could join their forces and give Dr. Carter's company a chance to do bigger things than he had at first anticipated.

According to Dr. Carter, he never went so far as to let the duke get any control of the Church and School Social Service Bureau—the name of the company which had been conceived by the doctor—and that may have been one of the reasons why Manchester found his way blocked.

As it stands now, Dr. Carter has withdrawn his company intact and will proceed to organize on the lesser basis on which he intended to operate before the English nobleman came to him with the larger proposal. Dr. Carter has rented new offices, which will be ready for him shortly.

Carelessness in Money Matters

Two other concerns, the Topical News Company and the Daylight Screen Company, are lost in the shuffle so far as the International League is concerned, so it is reported.

The Duke of Manchester, according

to reports which have been appearing in the papers for the last few days, is involved in several things of a more or less disconcerting character, including the return of checks which he is alleged to have handed out, while money to his credit in the bank was more conspicuous by its absence than by anything else.

His friends have said that all of these things will be taken care of and the duke cleared from any suspicion of evil intent. In addition to the checks, a number of creditors, both of the nobleman and of the International Education League, have been on the titled film man's trail for two or three weeks with a result that some suits are believed to have been entered.

A \$10,000,000 Vision

Several contracts which were made in the name of the International Education League by the duke are outstanding, and those with whom they were made are not feeling any too good about them.

One contract for \$702,000 worth of projecting machines is said to have been made with the Safety Projector Company, of Chicago. The Ambrosio company had made a contract with His Grace for about \$18,000 for a certain number of prints of a six-reel feature called "Life at the Bottom of the Sea."

This film was already cut up and was in process of re-arrangement under the direction of Raymond L. Ditmars, curator of the New York Zoo. The picture was returned to the owners in small sections.

Two or three of the employees of the league are said to have had iron clad contracts with the duke and a firm of accountants had a contract to organize the big office force on a basis of scientific efficiency.

Prof. Ditmars is thought to have had another contract with the duke for a series of pictures which were being made under the scientist's direction.

Manchester's scheme was a big one. He was going to send companies all over the world to make pictures. He had visions of profits of good size on a capitalization of ten millions and his vision even went beyond that. There was no doubt in the minds of any one associated with him that he was sincere, but it did not take long to convince the practical men who went to his aid that he did not have his feet on the ground all of the time.

Office Furniture Not Paid For

The losses to others as a result of the duke's venture are said not to have been large. It is reported on good

authority that about \$20,000 will cover all of the amounts.

Archibald S. White and his brother, Rollin W. White, are believed to have been the heaviest losers, although the former has been quoted as saying that he lost no money.

Some of the magnificent furniture and carpets with which the duke furnished his offices at 18 East Forty-first street was paid for, but the bulk of it was removed from those offices by those who sold it.

Charles J. Hite, president of the Than-houser company, was said to have been the big practical man associated with the duke, but it is known that he did not sign any papers or put any money into the concern, although he probably was about to do so when he met death in an automobile accident.

Mr. Hite's death has been given as one of the causes for the failure of the duke's scheme, and the war in Europe has been given as another, but reports coming from inside the league lead to the belief that Manchester's lack of experience in business, and especially in the film business, was the most direct and reasonable excuse for the crash.

Dr. Carter's Bureau to Continue

Dr. William Carter's Church and School Social Service Bureau, which was one of the unfortunate victims of the Duke of Manchester's abandoned International Education League, has taken new offices in the Hudson Building, at 80 Fifth avenue, and will be ready for business shortly.

Having drawn away from the duke's league, Dr. Carter now intends to go ahead with his original plans, which were broad as regards the United States but did not take in the entire world as did those of his titled associate.

With this in view, he has located his offices so as to be near the national religious and social welfare centers, which are to be found farther down town than the film headquarters of New York.

Will Be in Market for Films

When the new quarters are opened, a large number of these workers will be invited to come in and look over the enterprise and have the movement explained to them.

Dr. Carter has said that he will soon be in the market for a large number of films of the sort which he will use in his work. These will include subjects dealing with sociology, travel, education and religion and others of a wholesome dramatic or humorous import. He expects to be ready for work on October 15 and will try to start his service about the first of November.

The Inside Story of the Columbus Convention

By Samuel Bullock

IN order that my fellow league members in Ohio and the various states may not be misled, I am going to give them the plain unvarnished truth about the so-called "convention" at Columbus on September 15 and 16, even at the risk of expulsion for so doing.

On August 30, I read the official call and the lines, "If you are for or against censorship, be there. Let us hear what you have to offer as a solution to the problem."

Also, "Every member of the league will be given an opportunity to express his views."

Again, "*Do not stay at home* and then after the meeting is over *kick* at the action of the meeting."

Fourthly, "Remember, we elect all state officers and a legislature this fall who will make and enforce the laws for two years. We should know our friends, and legislation matters will come up at our meeting and, if you are not present it's your own fault and we will expect you to stand by the decision of the meeting."

"All Happened As Predicted"

At our meeting on Wednesday, September 2 (Cleveland Local No. 1), with 66 exhibitors present, I openly stated my suspicions, reiterated the same sentiment at a full meeting on September 9, was urged to go to Columbus on September 15, and everything happened as predicted—*only worse*—when I got to Columbus.

When I tell you that both our theatres have been, since September 3, "picketed" by the Operators' Union due to my refusal to accede to their demand for a raise from \$15.50 to \$21.00 for a 30 hours evening show; that I was arrested on September 8 for running film without censor "leaders," you may well imagine the perplexed condition of my mind.

I certainly was not "on pleasure bent." I am in the business to stay and am anxious to get rid of some of the things that now encumber us and prevent any additional troubles that may be foisted upon us. I desire simply to look after *my own* business.

Tuesday, September 15, found me at league headquarters, Southern Hotel, Columbus, awaiting the opening of the meeting.

It opened with fifty-four exhibitors and film men present at the 2 o'clock session.

"Free Banquet Failed to Draw"

This answer to over 700 invitations sent by our state president showed plainly that there is a lack of confidence somewhere. Even free banquet tickets failed to draw.

The session opened with the usual speech by the president, that I am so familiar with, "tinctured" with a few "non-harmonious" thrusts at yours truly as a reward for bringing half a hundred Cleveland "kickers" back into the league.

It grieved me to see such a display of spleen the first few minutes of the meeting after the "*Don't stay at home*" call.

It was commented upon freely by the film men who left the room when the executive meeting was announced.

In executive session, President Neff announced that "all those present who had not paid their per capita would be asked to withdraw or they would not be recognized as a "delegate" and a right to the floor would be denied them. A list of names was read off and yours truly was missing.

I tremblingly suggested that this could not be regarded as a "regular" convention inasmuch as no one present had been elected as a delegate.

He sharply informed me that he had the right, as state president, to call a "meeting" at any time, according to the constitution.

Wherein a Cleveland exhibitor throws some light on Mr. Neff's methods of "personally conducting" an exhibitors' league meeting, particularly the executive sessions, and explains how a perfectly sound solution of the censorship difficulty in Ohio was "killed" by being committed to the tender mercies of a handpicked committee.

I timidly quoted (reading it) his official call, dated August 30, in which "Every member is urged to attend." I also proved by Messrs. Ed. Kohl and Heinbach—his strong personal friends from Cleveland—that I had rejoined Cleveland Local the day I arrived from Dayton convention, paying three dollars dues which covered my per capita to November.

He contended that Treasurer Wilson had not received it and he announced that he would proceed, but announced that he "would insist that *all* must be 'regular' on the treasurer's books tomorrow."

NOTE: It developed shortly after, as the free tickets for the banquet were given out to members in good standing only, that seven or eight of his own "old guard" were in arrears.

He then *allowed* me to be seated and I felt truly gratified for his hospitable treatment.

Sworn to Secrecy

The executive session was then informed that he would insist that every "delegate" be put upon his oath "not to divulge to a living soul what transpired at this convention, and Brother Miller, of Cincinnati, would administer the oath."

Again I shuddered and shrinkingly asked Mr. Neff, "How can I report back these proceedings to my Cleveland fellow leaguers if I am oath-bound?"

Max Stearns, of Columbus, reminded him of the two smiling newspaper scribes present and he put his official O. K. upon them as "men of honor," but Attorney Lem Miller, of Cincinnati, who drew the censor law, reminded Mr. Neff that he, Miller, held no commission for Columbus.

Again I breathed easy at my narrow escape. He then announced he would "pass it up until tomorrow." Several resolutions were submitted and discussed; the good ones I voted for, the bad ones against and the suspicious ones I left alone.

On the resolution regarding the limiting of poster displays to one sheet, I voted "aye," inasmuch as Mayor Baker of Cleveland is raiding the show fronts on account of its being overdone and I have a case pending at the present time due to the fact that a Cleveland policeman pulled one of my three-sheets down on Labor Day.

The resolution got eight votes from the "uplifters" and "got it in the neck" from the "negatives," none of whom explained why.

They cannot.

This was Wednesday, after the committee's report and recommendation.

"Shall we sanction the endorsement of any particular trade paper," brought forth the suggestion that a certain paper was being favored by motion picture powers that be. We "allowed" that everyone should support the paper that served him best as an exhibitor—and it went through with a bang to refer the matter to a committee to report Wednesday. (Anyway, the Dayton National Convention settled this question.)

The question of "forming an association of manufacturers and exhibitors for mutual protection" was also referred to a committee to report Wednesday.

Take up New York Situation

The resolution endorsing the action of Wolff, of New York, in holding Sam Trigger to the amalgamation committee promises, per Dayton resolution, brought forth some real oratory from our worthy president regarding the awful sins of the "bolters."

However, I resisted the hypnotic influence of his flashing eye without a quiver and reminded him that I had kept my word, given at Dayton, anyhow.

Then I voted "aye" to his great surprise, I am told.

Some one suggested that conditions should be made better for the suffering exhibitors and film men who were suffering from lack of attention by the censor board to the delay in censoring reels and providing "official leaders" for same, thus holding up reels in a "I should worry" manner.

I perked up and smiled, remembering that the files of the trade papers would show where yours truly had predicted this very condition would arrive in due time.

Naturally also, I thought, "Here comes the discussion on censorship," and I also remembered the film host waiting outside, loaded with visible proof but "light" with depleted pocket books. We also reminded them that we were out on bail for the awful crime of showing a reel without a "leader" and suggested the boys be called in to enliven the proceedings, but Mr. Neff settled it by appointing a committee to report on Wednesday.

We had made several attempts in devious ways to bring on the censorship discussion, but the president was on the job, and I was single-handed and alone on the firing line, limited to five minutes, while he talked, warned, threatened and "conned" us *all* the time, right from the president's chair.

However, the previous discussion had received recognition and been referred to committee, so hoping for the best, I asked permission to read some resolutions to the body assembled, but Mr. Neff ruled me out of order. I reminded him that since he had permitted the previous question to be honored with a committee reference, he might at least "permit" me to read my resolutions also.

Choking Off the Resolutions

He finally condescended—after reading his "official call" to him—to allow me to proceed. I got exactly three lines of the "resolved" over the plate when he called me out of order. I feebly resisted his (private) parliamentary (?) moves until he finally promised to *allow* me to "bring it up tomorrow when a full discussion on censorship would take place, and not before."

Yielding gracefully, the horrible thought occurred, "Don't we get any censorship talk at the feed tonight?" and I thought of Joe Farnham and the Algonquin roof garden banquet and wondered where he was, as we adjourned at 6:30 to eat.

Prompt at 8, we lined up for the feast—and by-the-way it was a good one.

After two "bits" of vaudeville the chin music started. I think there were fourteen "speaking acts."

The "topliner" was a gentleman who sprung a "give-us-your-kind-applause" stunt by dramatically proposing that "We all arise and stand, as a mark of esteem to our noble president." I was the first up. I can "stand" for anything.

Everyone discussed censorship, including Brother Vestal, who of course isn't interested except as a "patriot." But how we did miss Maude Murray Miller! Poor lady! It was un-gallant not to invite her.

The censorship discussion went on, in spite of Mr. Neff's orders of the afternoon to "allow no discussion of the censorship question until Wednesday."

The "discussion" was limited, though—limited to "our friends," and as one-sided as a man with a short leg. Governor Cox's private secretary, Mr. Burba, rendered a touching monolog on William Lord Wright that got several "hands" and a bow or two. It was a "peach."

The Size of the "Crowd"

The program became monotonous to some of the film men and some trouble maker sent my name over by Brother Maddox to the "big chief" with a request that he put me on for an amateur act.

Maddox knows his little book, though, and our late "retired" national president couldn't see me, so the "explosion" never took place. We assured him, though, as he left the dais that he had not changed any in four years. Too bad! He had the makings of a great man but he was spoiled by Maddox. He assumed a look of injured innocence as he shot back, "What! Are you kicking again?" I then strolled arm in arm with Brother Wilson, national secretary, Ohio censor, etc., etc., who blithely assured me that he could censor fifty reels a day

and never wink. I believed him! He has doubled that record many a time recently.

(NOTE: I forgot to state there were 68 banqueteers, 40 exhibitors and the balance hungry film men and admirers. It must have impressed the Governor's secretary as an enormous crowd. The Governor is a victim of a "con" game, but the boys are waking all over Ohio and it won't be long.)

At the Wednesday session a rattling good speech by State Building Inspector Kearns put us all in good humor. It was a heart-to-heart, fair and square business talk, without affectation or bombast.

We really learned something of benefit as showmen. Cleveland welcomes Kearns any old time. Everything went on harmoniously until we introduced our little "Whereas" and "Resolved," as per promised permission by the president on Tuesday.

The Fate of the Resolution

Max Stearns said it was a reflection upon President Neff. For once Max was right, but it was never intended as such. The state organization is in a lamentable shape and I wanted to give Neff a chance to "square" himself in Ohio.

I insisted we had no right to inject censorship talk at our birthday party, inasmuch as the National Convention at Dayton had voted to condemn all forms of legalized censorship and had endorsed the work of the New York National Board.

We also reminded him that everybody at the banquet had been heard on the side of Neff's pet measure without giving poor me a chance.

After considerable fireworks, with National President Pearce as a spectator, Mr. Neff discovered my resolutions were not seconded and he took the only course he could take, while the "old guard" stood pat after I read the resolutions through. So well drilled were they that no one could be induced to second the same for the purpose of getting enlightened on the censorship question.

My resolutions offered a solution. The only one offered, as per "Call." Herewith I append the same:

WHEREAS, A condition now exists among the motion picture exhibitors of Ohio that is not conducive to harmony among said exhibitors regarding the present State Censor Law and its effect upon them as exhibitors and free citizens, therefore be it

RESOLVED, That in order to test the sentiment of all Ohio exhibitors, including league members and non-league exhibitors, regarding this all important question, we hereby ask that a mail referendum vote be ordered by National President Marion A. Pearce, in the State of Ohio; the said referendum to be conducted under the jurisdiction and supervision of President Pearce, assisted by a committee to be appointed by himself; the details of conducting said referendum to be arranged by President Pearce and said committee; the expense of said referendum to be borne by the Ohio Motion Picture Exhibitors League; and be it

FURTHER RESOLVED, That action be commenced at once by said committee in order that a full and complete vote of Ohio exhibitors may be registered as early as possible;

FURTHER RESOLVED, That all envelopes shall be opened and votes counted in the presence of National President, M. A. Pearce, not later than October 15, 1914, and that a majority of votes, either for or against the repeal of the Ohio State Censor Law, shall be recognized as the expressed will of all Ohio State exhibitors and all further action upon this subject shall thereafter be left to the good judgment of National President, Marion A. Pearce, for final disposition.

No endorsements were given to any one on the censorship question nor the censorship proposition in any form, but the above was "shelved" by the appointment of a committee—hand-picked—to look into conditions, give the law a chance and report at the Cleveland convention next February. I suppose I shall be fired by that time.

Motion Picture News

HAS THE QUALITY CIRCULATION OF THE TRADE

MOVING PICTURE NEWS EXHIBITORS' TIMES

Published Every Week by

EXHIBITORS' TIMES, Inc.

220 West 42nd Street, New York City.

TELEPHONE BRYANT 7650

Chicago Office, 604 Schiller Building

WILLIAM A. JOHNSTON.....	President
HENRY F. SEWALL.....	Vice-President
E. KENDALL GILLET.....	Secretary
H. ASHTON WYCKOFF.....	Treasurer
WENTWORTH TUCKER.....	Ass't Treasurer

WILLIAM A. JOHNSTON.....	Editor
LESLEY MASON.....	Managing Editor
WILLIAM RESSMAN ANDREWS.....	News Editor
H. ASHTON WYCKOFF.....	Business Manager
R. M. VANDIVERT.....	Advertising Manager
E. J. HUDSON.....	Circulation Manager
C. J. VERHALEN.....	Chicago Manager

This publication is owned and published by Exhibitors' Times, incorporated under the laws of the State of New York. The offices and principal place of business are at 220 West 42nd Street, New York City. The address of the officers is the office of the publication.

Entered as Second-Class matter at the New York Post-Office.

Subscription \$2.00 per year, postpaid in the United States, Mexico, Hawaii, Porto Rico and the Philippine Islands. Canada, \$3.00; Foreign, \$4.00 per year.

ADVERTISING RATES ON APPLICATION.

Copy for next issue must reach us by Tuesday, 5 p. m.

For Releases see Pages 72, 74, 76, 78

For Buyers' Guide see Page 71



Cuts and copy are received subject to the approval of the publishers and advertisements are inserted absolutely without condition expressed or implied as to what appears in the text portion of the paper.

Vol. X

October 10, 1914

No. 14

"When the Sleeper Wakes"

AT the last local elections in a certain large eastern city, a well-known lawyer and judge was chosen public prosecutor.

The election had been a spirited one, and every office was hotly contested. What was more remarkable was the part the motion picture exhibitors of the community had played in the fight.

The day after it was over, the new District Attorney was receiving congratulations from his friends. During the reception he was asked, by a representative of the press, what he considered the prime factor in his success at the polls.

"The motion picture theatres," he returned, without an instant's hesitation.

* * *

ONE important fact about this incident is that it is true.

Another and an even more important feature of it is that it can be repeated in any town or city of the United States, whenever the exhibitors of that community wake to the enormous power stored in the motion picture screen.

And that power can be applied, not only to a district-attorneyship, but to every office on the ticket,

local or state, from that of Governor to the tail end of the slate.

Indeed, no great imagination is necessary to conceive that several thousand motion picture screens, carrying messages to many millions of people a day, might have a marked influence upon the course of a Presidential election.

* * *

BUT when will the exhibitor wake?

When will he realize that he and his fellows have, in their motion picture screens, the greatest medium for appealing to public opinion ever known?

When will they realize that the screen is mightier than the stump speaker?

That the projection machine is mightier than the politician?

That, whereas many of them now tremble at the bosses for the safety of their business, the bosses should tremble at them for the safety of their power?

That when they are as fully aware of the power of the screen as the politician is, the politician will cease to molest them, as he has ceased to molest other industries with which he has found it unwise to meddle?

* * *

THERE are lines of business which have been compelled to buy immunity from the politician.

But the motion picture exhibitor need never do that.

He can command, where others have to beg.

He can dictate where others have had to implore.

For he holds in his hands the power that can make or unmake the politician.

And the politician knows it, but he also knows that the exhibitor is not yet aware of it, and he is trading on the exhibitor's unconsciousness of his own strength.

* * *

AS an individual, the exhibitor is an easy prey. As a member of an organization, he is invincible.

The day the exhibitors organize and present a solid front to the politicians, their projection machines will serve as a battery of artillery to keep the enemy at a distance, and their screens will be the arena in which more than one political conflict will be decided.

But when will the sleeper wake?

The War Tax Off? Well, Not Exactly!

THERE has been a great deal of rejoicing during the last few days in certain quarters of the motion picture industry, over a report that the photoplay theatres had been exempted from the Congressional war tax.

Unfortunately, the rejoicing is premature, for the report has been proved to be without foundation.

The tax on motion picture theatres has NOT been abandoned.

Congress has NOT granted immunity to the exhibitors, except in towns of less than 15,000 population, as originally provided.

* * *

THE measure has passed the House of Representatives, and is now before the Senate. In all probability it will go through without change, so far as the motion picture industry is concerned.

Instead of indulging in unwarranted ecstasies over a false rumor, it would behoove those upon whom the tax will fall to consider the consequences of their foolish indifference to organization. And those who spread the report might ponder with advantage the wisdom of verifying rumors before circulating them.

"THE KEY TO YESTERDAY"

(Favorite Players—Four Reels)

REVIEWED BY CLIFFORD H. PANGBURN

DUAL identities have constituted a favorite theme for story writers, and many stirring narratives have been founded on this idea, but when the situation is complicated by the complete loss of memory on the part of one of the persons concerned a most entertainingly intricate situation may be expected.

Such is the case in the book by Charles Neville Buck from which this film is taken. To present such a story on the screen is a difficult task because portions are likely to appear obscure, or else too much space is taken in explaining matters.



SHE RECOGNIZES THE PAINTING

The Favorite Players have avoided both of these errors, and have produced a film which offers an excellent story.

The scenes are laid in France, the western part of the United States, South America and on shipboard. In the exteriors there is a happy combination of attractiveness and realism. The places selected are of such a nature as to furnish pleasing and, in many instances, beautiful backgrounds, besides representing what they are supposed to represent. The scenes on shipboard are also effective.

A careful attention to details has added to the strength of the picture. An example is the portrait which the artist is supposed to paint of his sweetheart. In many films where this idea is introduced one of two equally bad courses is usually adopted. Either the painting is always held so that the audience cannot see it, or else some miserably drawn sketch is used which makes the heroine seem ridiculous.

In "The Key to Yesterday" the problem was solved by the simple process of using a really good retouched photograph. This may be a small thing, but it typifies the general good sense which has been shown in the production of the film. The correct turn has been given to scenes regardless of a little extra trouble.

The photography is another strong point. Except for a sunset at the end of the third reel there is no effort to obtain special effects, but the camera work throughout is as it should be.

Carlyle Blackwell appears in the film at the head of his own company, this being his debut in that capacity. His work in leading parts for other companies is well known, and he handles his dual role in this picture with customary vigor.

He is seen first at Marston, a revolutionist and all around bad man in a South American republic. Later he is the artist Marston, who after losing his memory is known as Saxon, thus making the part practically a triple one.

Edna Mayo is an attractive Duska Filson, and plays the part with a becoming charm. In the latter part of the picture her work appears to better advantage than when she is first seen. Other well played parts are those of J. F. Dillon as Rodman, another revolutionist; John Sheehan as George Steele, and John Prescott as Robero, an ambassador. The other minor roles are well played.

The story tells of an artist who comes to America shortly after his marriage. A jealous model has stabbed him in the right hand, and thus made it impossible to work. While in the West he is robbed, and receives a blow on the head which makes him forget his past life. He shows his artistic ability, and a painter sends him to an art school.

He is successful and later becomes engaged to an American girl. Prior to this a revolutionist has made a sensational escape from a firing squad in a South American republic. He is an exact double of the artist. The official who sentenced him meets the artist and supposes him to be the same man.

Not knowing his own past, he thinks the man may be right. He tells his story to his fiancée and leaves for South America to find out whether it is true. He has a number of adventures, but finally learns he cannot be the man, as the scar is on his right hand, while the revolutionist has one on his left.

His fiancée follows him. A revolution breaks out and the artist is slightly wounded. A friend puts him on a ship for France. There he finally finds his home and learns his identity.

"THE ADVENTURES OF KITTY COBB"

(Warner's Features—Four Reels)

REVIEWED BY CLIFFORD H. PANGBURN

THIS picture is founded on the series of drawings made for a newspaper syndicate by James Montgomery Flagg. The opening scene shows Mr. Flagg at his drawing table executing a sketch of the heroine at his usual mile a minute clip. This concluded, the real story commences, and things move at a lively pace for the remainder of the four reels.

There is not a great variety of scenes in the film, but



KITTY'S ADVENTURES OVER

this is no fault and is in keeping with the requirements of the story. The action takes place in and about New York. Marian Swayne, who plays the title role, makes such a charming Kitty that one can forgive her for her tendency to overact in some of the more dramatic parts. Harvey Thomas, who plays opposite her, is troubled slightly by the same fault, but on the whole, handles his part in a satisfactory manner.

At least one remarkable coincidence occurs in the course of the story, but this is no very great departure from real life, because without such extraneous aid kidnapped girls are not often found until it is too late.

Kitty, before she leaves home, discovers a foreign count trying to spy on the actions of a young inventor who is working for the government. Later she seeks her fortune in New York, and eventually becomes the secretary of the inventor's mother. Here she meets the foreign count, who is engaged to her employer's daughter. Fearing exposure the villain has her kidnapped. After some thrilling fighting she is rescued by the inventor.

"HYPOCRITES"

(Bosworth—Four Parts)

REVIEWED BY JULIAN M. SOLOMON, JR.

MORALITY plays are not new by any means, but some are stronger than others. In the class of the strong plays is "The Hypocrites," a four-part drama, scheduled for release on October 19 through the Paramount Program. The name is well chosen, inasmuch as Miss Weber does not hesitate to flay hypocrisy in every form.

The play is sure to create great discussion, and handled by a less able writer or one with less puritanical ideas would receive adverse criticism.

The story is divided into two parts, a prologue, introducing the characters as monks and nuns and then brought up to the present time with modern settings and twentieth century



HYPOCRITES!

people. The cast of the prologue is: Gabriel, an ascetic, Courtenay Foote; the Abbot, Herbert Standing; a nun, Myrtle Stedman; a magdalen, Dixie Carr; a queen, Adele Farrington; and Truth, Margaret Edwards.

The cast for the play of the present time is: Gabriel, a minister, Courtenay Foote; a pillar of the church, Herbert Standing; a choir singer, Myrtle Stedman; a magdalen, Dixie Carr; an aristocrat, Adele Farrington; and Truth, Margaret Edwards.

As the story runs, Gabriel, an ascetic monk of olden times, labors to perfect an image of Truth, consecrating himself with fasting and prayer and keeping his work a secret. One monk, bolder than the rest, spies upon him, but is blinded by the light of Truth and can see nothing.

The unveiling of the statue is made a fete day, and all gather to listen to the address of the Abbot, who himself consents to unveil Gabriel's gift. The covering is pulled aside, and there stands a figure of Truth, naked. Unable to see with the eyes of the spirit, the people with one accord rush upon Gabriel, and kill him.

Only two can look upon Truth unflinching, a little child, and the woman who loves Gabriel. A magdalen looks upon the statue and falls prostrate, weeping bitterly. The woman who loves him covers the dead Gabriel with her veil, which turns from white to black as she bends over him. Nearby the magdalen crouches.

Thus ends the prologue of the story, which, told in a reverent and deeply religious vein, makes an indelible impression, and prepares the spectator for the modern scenes which are the main theme.

The present day story opens with a view of Gabriel as the minister of our everyday life, frail and ill, but fired with divine inspiration. In the congregation are the same people who, in the prologue, stoned the monk to death. Now they are bored or shocked, as the case may be, by his denunciation of hypocrisy. Only the woman who loved him, now a singer in his choir, and the magdalen, who kneels in prayer after the others have gone, understand. The spying monk is now

a choir boy, surreptitiously reading a newspaper during the service.

Left alone after service, the minister finds the newspaper, with its reproduction of Faucher's famous painting, "The Truth," and vague memories stir. He sinks into a dream. His body, in the form of Gabriel, the ascetic, leaves his present-day body and, accompanied by Truth with her mirror, visits the various scenes of the story, showing him in this wondrous mirror of hers, the real actions of the characters.

The photography in this feature is really wonderful, showing what the expert camera man can do. Not content with double and triple exposure, George W. Hill has produced even sextuple exposure to make this picture more marvelous. In fact, the photography is of such merit that it has been brought favorably to the attention of the Franklin Institute of Philadelphia, Pa.

"THE MAN IN THE CELLAR"

(Films Lloyd—Five Reels)

THE second of the Webb series of detective stories, the first being called "The Black Triangle." The stories are complete in themselves. Ernest Reiches enacts the part of detective Webb as in the first picture. It is produced in five reels by Joseph May.

The story is most mysterious in character and has sufficient interest to sustain the action throughout. The first three reels are entirely enshrouded in mystery, the audience not being given an idea as to the outcome.

In speaking of "The Black Triangle," the antecedent to this picture, Detective George Dougherty is said to have thought it the best criminal detective story ever brought to this country. The second one certainly ranks very high in comparison with many of those the writer has seen.

A scene which cannot fail to grip the lover of tense situations is that in which the conspirator, fearful of instant discovery, makes his escape through the window. Every move of the actor intensifies the scene.

Following the hearing of strange noises Detective Webb is called in by the Baroness, and on entering next door finds a man entombed in a box in the cellar. A small dog which had been with him disappears in the excitement. On recovery the man tells of his trip from Egypt with the plans of a new gun for the government. This had been stolen and he had been knocked senseless.

Webb captures one of the conspirators and impersonating him goes to a secret meeting. He escapes from here with the key to the plans and goes at once to police headquarters. He



THE CONSPIRATOR ESCAPES

is asked, "Did you catch your men?" and replies "No. But I think they will drop in at any moment."

A little later his prediction comes true. The criminals are brought to the station house and arrested. A little cleverness on his part had worked the trick.

For sheer suspense this film will not fail to make a strong appeal to the part of the public liking mystery.

"A PRINCE OF INDIA"

(Eclectic—Four Reels)

REVIEWED BY CLIFFORD H. PANGBURN

PERHAPS the best evidence of the good quality of this melodrama is the fact that the most spectacular scene in it does not stand out all by itself, although it is really a remarkable piece of work.

In other words, the production is well balanced and is so constructed as to avoid the common error of bringing out the high spots as spectacular but unattached incidents. Events move along in an orderly manner and at an even rate.

The outdoor scenes have been selected with care, which



THE STRUGGLE ON THE BALCONY

results in effective back-grounds, even for the more unimportant happenings. The sensation of the film is in the fourth reel when a regular, honest-to-goodness trolley car plunges off from a bridge which must be fully a hundred feet in height. This impromptu diving act is supposed to take the villain to a timely death.

The car incident occurs when the prince and his friends have overtaken the thief who is attempting to make off with the famous ruby. The crook has commandeered a surface car but this plebeian vehicle is easily overtaken by a motor.

The prince leaps from the machine to the rear platform of the trolley with all the polished ease of a confirmed commuter. Once on the car he engages in a furious fight with the thief.

This occurs on the front platform while the car runs wild, and is an ingenious scene excellently photographed. The thief is finally overcome, and with the precious jewel in his possession the prince leaps off just in time.

The next moment the car dashes out onto a high bridge, jumps the track, crashes through an iron railing and plunges into a rocky gorge all in a style which is sure to bring an audible gasp from the spectators. It is a most creditable piece of work and has been utilized to its fullest extent.

The interiors are for the most part effective although the reception room of the hotel leaves something to be desired in the way of luxury. The lighting effects are well handled, the moonlight scenes being quite realistic.

The cast includes a number of capable actors. The title role is played by Thurlow Bergen, a trifle coldly perhaps, but nevertheless well. "Smiling Billy" Mason makes a debonair young reporter, who must have some income besides a newspaper salary if one can judge from his clothes.

William Riley Hatch is a conventional and therefore convincing villain, while M. O. Penn gives dignified portrayal of the Rajah of Myore. Elsie Esmond appears an unwilling "villainess" in a cast almost without feminine members.

The story concerns the attempted theft of the "Kiss of Death," a priceless ruby belonging to a visiting rajah. The thieves are at first foiled by the accidental loss of the gem. It is found by a "cub" reporter, who plans to give it back in the morning but loses it while walking in his sleep.

The prince, who is the son of the owner, recovers it only to be robbed by one of the thieves. He in turn is robbed by

his companion. With the help of the reporter the prince is soon on the right track and the ruby is recovered as mentioned above.

"THE TREY O' HEARTS"

(Gold Seal-Universal—Tenth Chapter)

REVIEWED BY PETER MILNE

GEORGE LARKIN has had many an opportunity in the preceding installments of "The Trey o' Hearts" to demonstrate his remarkable acrobatic ability, and he has come through his many daring feats with flying colors.

But due to his death defying performances, Cbo Madison has been somewhat neglected from this angle of the story. But here she blossoms forth and proves that she is just as good an acrobat as her male companion of this series.

Perhaps an added touch of excitement is given to the picture when one sees a woman gaily jumping on freight trains when they are going at great speed, climbing over the roofs of the cars, and jumping from railroad trestles of great height.

It furnishes excitement enough to see a man performing these feats of agility and daring, but if there is room for any more thrills they certainly come when a woman is seen performing the stunts that no ordinary man would volunteer to do nor could accomplish with any great alacrity.

All the action of this picture takes place on the railroad tracks, and numerous chases of engines, hand cars and freight trains create such a feeling of suspense that if much more of the same variety of action were furnished the spectator would be near a nervous breakdown.

The fact that the action transpires on the railroad tracks must have put the company to quite an expense as a great amount of track length was used, and no other trains appear except those that are directly needed to further the plot of the story.



ALAN, ROSE AND BARCUS FLEE TRINE'S PARTY

Near the end of the last reel, Rose, Alan and Barcus are in a caboose, which has been cut loose from its freight train by Judith. It stops on a high trestle. In a rapidly approaching engine are Marrophenat and some others of Trine's party.

The engineer, so taken up with the gun that Marrophenat is holding close to his ear, neglects to see the caboose still in its path. Just before the engine collides with it, the three alight and descend to the ground below by means of each other's assistance.

Then the engine telescopes the caboose and shatters it to pieces, hurling bits of it far and wide. Here the chapter ends.

Tom Walsh as Barcus, a side partner of Alan's, is assuming much importance as the story progresses. He is every bit as daring as the more distinguished star, or he appears so at least on the film. Ray Hanford as Marrophenat, the lieutenant of Trine's, is another important individual.

Indeed, the work of the whole cast is of sufficiently high standard to deserve mention.

"THE MILLION DOLLAR MYSTERY"

(Thanouser—Fifteenth Episode)

REVIEWED BY J. BURROUGHS NOELL

IT is well nigh impossible to maintain interest throughout a long succession of episodes, unless each one is thrilling in the extreme, and perhaps what is more important, unless each one is thoroughly intelligible in itself, standing complete as a unit but at the same time acting as a link in a chain.

The effort of the Thanouser company in its great serial has been toward this end and it is probably no exaggeration to say that the firm has succeeded as well as possible under the circumstances. An almost exhaustless supply of human ingenuity has enabled the producer to carry on the story from episode to episode without the slightest evidence of diminution of interest in the adventures of the girl harassed by the band of conspirators.

And now that we have reached episode No. 15, the prediction may be hazarded that the interest will not only not diminish, but that it will steadily increase from now until the end, because the threads of the story have now become fairly defined, and it is just possible that some alert minds may begin to see signs of the solution.

The hanging together of the whole in one connected chain creates suspended interest from one week to another, and this is perfectly satisfactory to the multitude who never by any chance miss seeing each release.

But there are many other persons who are not so fortunate; they see one episode this week, and then miss one or two before they see another. And perhaps they do not have the opportunity to read the story in the dailies.

To them it is very irritating if their understanding is thus hampered, and it becomes absolutely impossible for them to catch the drift. But this exasperating circumstance has been eliminated by making each episode tell a complete story in itself.

Always one event takes place in each installment, and there is never any carrying over of one occurrence into the next. Even the outcome is not withheld, but the consequences are made plain at once, and when the next installment comes it depicts another and a new adventure.



THE ESCAPE IN THE HYDROPLANE

But of course the same people and the same purpose are carried over from one week to another, and thus is that binding and gripping suspense that draws crowds to the theatres night after night maintained.

The fifteenth episode is called "The Borrowed Hydroplane." It introduces a little open-air excitement. The conspirators have gotten hot on the trail of Florence and have captured her. They threatened her with that basest of all threats, to disfigure her for life unless she reveals the hiding place of the money.

They carry her off in a boat to execute their evil design. But Jimmy Norton gets on to what has happened, finds a

hydroplane waiting for him to jump in, and promptly starts on his rescue trip.

He overtakes the boat, signals Florence to jump out, picks her up out of the water, and makes off before the conspirators have time to realize that they have been outwitted once again.

"THE NIGHTINGALE"

(All-Star-Alco—Five Parts)

REVIEWED BY WILLIAM RESSMAN ANDREWS

"THE Nightingale" is the first motion picture play written by a well-known dramatist for a legitimate star. Augustus Thomas has brought all his skill to bear on the



THE VOCAL INSTRUCTOR FINDS THE NIGHTINGALE

newer art of screen dramatization, and has provided Ethel Barrymore an excellent vehicle for her abilities. In this, her debut in film drama, Mr. Thomas shows the stage management expected from one of his finesse.

The play will enhance the reputations of producer and actress, and afford an opportunity for admirers of Miss Barrymore to see their favorite in a role permitting her to exercise all her charm and wonderful impersonation of a difficult character.

"The Nightingale" stands out for the variety of incidents which have allowed the director a chance to exercise all his ingenuity in divising picturesque settings. Their scope is so wide that the spectator sees, on one hand, events staged amid the squalor of the tenement district, and, on the other, the gorgeousness of Grand Opera scenes, and the luxurious surroundings of wealth and refinement.

And with all these apparent extremes there is nothing incongruous in their relations to the main current of the photo drama. Every scene is made to dovetail and follows as a natural sequence to what has gone before. This is indeed a triumph of stagecraft.

In a hand of lesser cunning this would have degenerated into mere padding, the fault of many motion picture dramas aspiring to the dignity of a feature.

For all its length "The Nightingale" holds the attention of the audience, who are constantly impressed with the dramatic qualities of the play and the finished acting of the cast supporting Miss Barrymore.

The death of the old organ-grinder by the explosion of a Black Hand bomb is unusually thrilling.

The plot deals with an Italian girl possessed of a wonderful voice. A wealthy young man hears her singing on the street, in company with her father, an organ grinder, and falls in love with the unknown. He searches for her and persuades the girl to go abroad and cultivate her heaven-gifted vocal powers under the best master in Europe.

Through a misunderstanding as to her benefactor's motives the couple are separated. The singer makes a hit in grand opera; and the two are reconciled after her lover, brought to a realization of her pure character, makes known his true feelings and asks her to become his wife.

The Exchange and the Manufacturer

(Continued from page 29.)

bound to creep into some of the best plays and destroy an otherwise perfect effect. A mistake of that sort is like a drop of ink in a glass of water. It serves to discolor everything.

He forwarded intermittent reports to the manufacturers, dilating on his discoveries. Although the constant stream of letters that he sent partook of the nature of nagging, they produced good results, for they were prods in the right direction.

If all the managers did likewise, there would be fewer careless directors in the business. The plays, moreover, would be more carefully scrutinized by a selected staff, before they were sent out. Jensen didn't care on whose toes he trampled in this case. Such men, he figured, were better outside of the business.

There was still another important thing which Jensen designated a function of the exchange—the promotion of new theatres.

He was constantly examining his field to discover a likely location for a motion-picture house. He succeeded in establishing four, thereby adding that number of clients to his exchange and extending the market of the manufacturers.

THE first manager whom he was instrumental in setting up in business was one of his solicitors. Jensen was always on the watch for promising talent to assist him in his work. This solicitor had a creative mind, backed by a dogged perseverance and topped by a tremendous ambition.

He had not only made good as a solicitor and assisted materially in building up Jensen's clientele, but had studied exhibiting at first-hand and was qualified to speak authoritatively about the business. He had, at times, substituted for the expert of the combination.

Jensen discovered a likely-looking spot for a small theatre, catering to the best class of people, and immediately got into touch with a retired merchant in the community, who was willing to advance the requisite funds.

With a little time and judicious engineering, Jensen started his solicitor as an exhibitor and now has a loyal client firmly welded to his exchange.

The next venture resulted in a community house started and supported by those in the vicinity. In the first case, Jensen relied upon the personality of his solicitor to achieve success.

In the second instance, the theatre was definitely a neighborhood project. The majority of the shareholders were residents in that locality, the shares being sold by personal solicitation. Each shareholder agreed, in addition to the money paid for the shares, to buy at least two tickets to the theatre every week.

By this means, the nucleus of a steady patronage was insured from the very beginning. They gave the manager, who was allied with Jensen, free rein in running the theatre, promising not to interfere with him in any way.

The other two houses were established with the aid of a commercial bureau, through which Jensen interested several moneyed men in his schemes.

The mere fact that he personally stood behind the new ventures in most cases sufficed to settle the matter. It required little investigation to satisfy the most suspicious investor as to Jensen's business sagacity and reputation for square dealing. And none of those who risked their money at his suggestion had cause to regret the step, for Jensen resolved to do everything in his power to make the new theatres a success—which he did.

THERE was still another field that Jensen entered. The companies that had supported him in his initial campaign, when he first took hold of the exchange, insisted on him becoming their agent in his vicinity. Jensen realized the importance of having the most up-to-date accessories installed in the various theatres, so he finally consented.

A separate room was given over to the samples, all of

which Jensen thoroughly tested before he agreed to handle them. This formed an additional incentive for the exhibitors to pay his quarters a personal visit.

As they were always receptive where new methods and instruments were concerned, Jensen found the accessories assuming more and more importance in his business.

The quarterly meetings of the local association were admirable opportunities for demonstrating the efficacy of the new devices. Cuts, furnished by the manufacturers of the new articles, appeared in the bulletin in the intervals with the results of Jensen's examination.

This served to push sales at dull times and keep the exhibitors awake to the fact that the house proper deserved fully as much attention as the program.

THESE and many other things Jensen evolved to help along his proposition. That he was so signally successful may be attributed to the fact that, whatever, he undertook, generally had a rock-bottom of unselfishness in it.

His methods were business-like.

He believed in claiming a legitimate profit.

But he didn't seek to gobble everything; he was willing to let the other fellow live.

In spite of the vituperations of his rivals, he succeeded far better than any of them, because he paid strict attention to constructive and not destructive criticism. If anything was radically wrong, he did not burst out into a rage, but conscientiously sought the flaw. If he were to blame, he would be the first to acknowledge it.

"THE MAN OF THE HOUR"

(World Film—Five Reels)

REVIEWED BY PETER MILNE

IN "The Man of the Hour," the producers have given to the public a picture that will by no means fail to gain its appreciation. It has all the qualities that go to make an excellent picture, and no one of them has been at all neglected.

Its plot although somewhat conventional is developed with great skill, both on the part of the principal of the cast and the director. And a picture played by an accomplished cast, no matter how old the thread of the story, is sure to be well received. In fact, its conventionality may easily be overlooked.

Old though the plot may be it is quite intricate, but at no time is one in the dark as to what the action makes reference to. This for the most part is due to the fine interpretations rendered by the leading players, and then again the scenes have been cleverly arranged, flash backs and close ups appear in many places, where by another director a subtitle might have been employed.

Playing in the title role is Robert Warwick, and he gives a fine characterization of the man who, although he has gained his high position as mayor of New York, mainly through the workings of a political ring, utterly forsakes it and turns all his power and attention to the people who elected him. His acting throughout is practically beyond criticism.

Supporting him is a cast no less competent. John Hines as young Percy Wainwright holds the principal comedy role of the picture and carries it off well. Chester Barnett as Joe Standing, Garrison's partner in the West, has a part which calls for both dramatic and again a little humorous acting.

Ned Burton as the political boss, finally conquered by Garrison, embodies the popular idea of such a person, fat, and always accompanied by a cigar, which he chews vigorously when the occasion requires.

Eric Mayne is the boss' aid, and the man who ruined Garrison's father, and Belle Adair, plays the daughter, the girl whom Garrison finally marries. Alec B. Francis has a small part as the young man's father, but carries it off well. The rest of the cast, although appearing in small parts, seem to have a good understanding of their roles.

It seems rather queer that an allegorical touch should be brought in at the end, showing the political boss standing above the graves of the poor, receiving, as may be gathered from their outstretched hands, their curses, and the picture would seem better if this part were left out.

SPECIAL FILM REVIEWS

of Foxicus." (Kalem. October 2.)—Happy burlesque and dignity of ancient Rome. Ruth Poland. The re rich, as, for instance, d hero of the "Eternal cigarette with all the of a Broadway dude and ch away with never a dire consequences that

are magnificent and keeping with the luxury ment of an earlier day. ken on the grounds of stablishment of a Cali- aire, not as one might o believing, the estate of erres.

of Hope." (Victor. Friday, October 2.)—The directed by Harry Myers ranks of the Universal l starred in by him and heby. Repentance and win for the doctor the e had long desired, and him off for another man. meets with death. Some this, although the story hly too emotional for

le of Lutie, the False Essanay. Wednesday, 16.)—Lutie had a notion ld sing, and she taxed her the hundreds for profes- tion. She then proposed at she could do by giving Things went in apple-pie tie thought, until the next en she took a hasty glance What they had to say a shame as far as Lutie but for everybody else was killing, so enjoy-

substance of George achievement on the trite, one might say, d to read the remarks de makes in his best y delicious.

Life." (Lubin. Two ay, September 17.)— na of superior order. amatic situations that c powers of the play- st in their effort to nderstood. emary Theby in the

leading part as Cora Tracey, the propriess of a gambling resort, and Anna Luther as her daughter, from whom she wishes to hide her way of life, the genuine intensity of the acting overcomes the difficulties that the story has laid down. The others in the cast are Harry C. Myers. Harry Wilgus and Beatrice Inman.

"The Way of His Father." (Essanay. Tuesday, Sept. 15.)—The eternal rebellion of the young against following in the footsteps of those who have preceded, the striving to reach out into new fields is the theme of this drama that is adapted from one of the Munsey magazines.

The father, a physician, desires his son to carry on his practice in the little home town after he completes his course. The son gets a chance to step into a field that offers greater opportunities and decides to leave home. The father falls ill of a broken heart. The boy then sacrifices his own future to comply with his father's wishes.

"The Twin Brothers Van Zandt." (Lubin. Two reels. Wed., Sept. 16.)—The exact likeness of the twin brothers enables the scenario writer to work out a very unexpected ending in this two reel feature. A dancer has come to the home of John Van Zandt to blackmail

him, and John, the brother, comes in to plead for his niece Rose, whom John has disinherited on account of her marriage to an artist.

John loses his temper and almost strangles the woman. The sight affects Peter's heart and kills him. John then pretends he is Peter, and while his nephew takes possession of his property, he lives with his niece. But he gets a new will into the hands of his lawyer, and in the final scene the nephew is ousted as John discloses his true identity.

John Ince plays the dual part of the twin brothers. Mildred Gregory is the dancer and Villette Stringer for niece. If the transformation from one brother to the other was just a little clearer the picture would be more easily understood.

"One of the Discard." (Kay-Bee-Mutual. Two reels. Fri., Oct. 2.)—A powerful and logical drama of the gold fields of the West where the search for the shining dust is the sole thought of man, and how to get it away from him the sole thought of women.

The play develops through a series of dramatic incidents that lead to a fine climax and keeps the spectator in doubt as to the conclusion until the very end.



SCENE FROM "HYPOCRITES!"—BOSWORTH-PARAMOUNT FEATURE
(Released October 19)

A young miner deserts a woman of the dance-hall and goes home and gets married. Later he goes into the gold fields again, he is thrown in her power while drunk, and instead of revenging herself upon him, she sends him off to his wife and child.

"Her Awakening." (Majestic-Mutual. Two reels. Sun., Sept. 20.)—The construction is somewhat loose and crude, but the story has splendid dramatic possibilities. An heiress is shoved over an embankment by a physician cousin who wishes to get rid of her for the money.

She is found alive, but her memory is gone. An operation is advised, and the surgeon happens to be the cousin. But before the operation he is arrested for the forgery he has committed, and so is gotten out of the way. The girl regains her memory but forgets the young man who has aided her. He has to begin his wooing anew.

Several of the most important incidents hang too much in the air, and are not connected closely enough to seem reasonable. The hospital scenes are presented with faithful reality.

Blanche Sweet, Ralph Lewis and Wallace Reid play the leading roles.

"The Adventure of the Smuggled Diamonds." (Edison. Mon., Oct. 19.)—Octavius the amateur detective pulls off a pretty piece of sleuth work in this, the tenth story of the series by Frederic Arnold Kummer. He meets a nice girl on the Celtic and she presents him with a cane.

About the same time he learns of a big smuggling case and sets about to do a little prying. He suspects a musician, accuses him, and gets into difficulties with the customs officers for his pains. But he finds the diamonds after all, inside the cane. The girl comes back to get them, but Octavius is too smart for her and hands her over to the police, with never a feeling of tenderness for her in the great satisfaction of having found the diamonds.

Barry O'Moore and Margaret Moll play the leading parts in their usual capital manner.

"Father's Beard." (Edison. Thursday, October 5.)—That the mere growing of a beard could cause all the trouble that befalls the drummer and father whom William Wadsworth impersonates in this picture would be unbelievable, unless you saw it all happening before your very eyes.

Then every detail of it seems absolutely natural, and the men folks will be extremely wary in satisfying their vanity with the soft, curling whiskers, no matter how great their envy of the other fellow.

At the same time the fun that grows out of a little innocent caprice is not to be overlooked, and it proves that it does not take a lot of horseplay to arouse even hilarious laughter.

Chicago Censors Make Wholesale

(Continued from page 37.)

markable opportunity of inspecting the methods upon which France is conducting her mobilization and supply.

"The effect of the war on the Continental trade? I am afraid there will be practically no trade there for a long time. As far as I could gather, production is almost at a standstill. This applies even to Italy, which is not at war. Moreover, there is practically no public for the shows, even if they could succeed in keeping open.

"In England and America? I cannot speak with much authority about this country, but I have reports from the States that business is good. Such financial adjustments as were necessary have been made. Speaking as an outsider, it seems to me the British trade will go on successfully as long as normal methods are followed. As far as the American Company is concerned, we are out to consider and assist our customers in a business and financial way as much as possible.

"At the same time exhibitors and renters should realize that the manufacturer cannot bear all the financial strain. He has big regular liabilities to meet for stock, chemicals, salaries, etc.

"I am glad to say there is every sign that the best class traders in the other sections of the industry realize this and are supporting the manufacturers. It rests largely with the exhibitor to make the indefinite continuation of the trade possible.

"As long as he is doing normal business he ought to make normal payments and so keep the whole machinery of the trade working in an easy manner. Other methods cannot but hamper the renter and manufacturer and thereby affect his own future business."

Rowdyism at Chicago Theatre

The Biograph theatre at 2443 Lincoln avenue, and the Vitagraph theatre at 3143 Lincoln avenue, both under the same ownership, were the victims of labor trouble on Sunday night, September 20, when several unsavory smelling bombs were thrown in both theatres. The patrons of both theatres were forced to leave until the odor had been cleared away.

Labor trouble is the reason given by the manager, whose policy it has been to employ operators affiliated with the American Federation of Labor. Recently two representatives of the I. B. E. W. visited him and, he claims, threatened to ruin his business if he refused to hire their operators.

Harry Pollard, producer of the Beauty subjects, is putting on a one-reel comedy, "Winsome Winnie." A good many of the scenes were taken out at Oak Park, California.

Fred Gamble, character man, is certainly some bare-back rider and afforded lots of amusement for the people resid-

ing near the location in were taken. Fred says v ing he believes he could of the jockeys that tal look like the proverbial

Sydney Ayres, one o directors, is producing two-reel subject writt Eason, an assistant dire

Many of the more i were taken at the Santa park. The meet afforded necessary to the product

Claud Erby, well kn Middle West picture circ Saturday, September 19, of George Kleine's Dalla He succeeds W. G. Tod

"Naked Truth" Now Re

Mr. Erby had a long experience in both the picture fields, and it is that the genial personal him so many friends in t will stand him in good

All Kleine offices ar "The Naked Truth," subject made from a

French novel, "La Fenu This was the Kleine opened the doors of the theatre, New York. Th tures the European actre Borelli, who duplicated Ward's American succes President."

By the terms of her George Kleine, no motio be shown in a city at the is showing there on the le

The Peter P. Jones has released a three-re made for it by the Ind Picture Company, entit Honor of the Eighth."

This was enacted by a ored actors, and also incl eighth regiment of Illinoi tiful scenes. This picture the Pekin Theatre for eig

Walter R. Early, who terested in the Consume Company, recently s, hie in that concern. Mr ed, art der way the filming m ac by one of Chicago's

The attractive li d by connection with G the fa film, "European Ar, ther tempted many exhibit ain edulous use of such, A th with other alleged, imp, s a ell.

Such practice is ble in a moral sen ous. Exhibitors ible using the Kleine rs de tion of any but Kl rat

The new Vista ' dra star est picture palace, on, gath at Forty-seventh the avenue with the ry t "Antony and Cleose

Dauntless, daring, romantic is Bess of The **BLAZING SEA**

The story of a light-house keeper in league with dynamite smugglers. There are furious flames and terrific explosions—and the light-house with its tiny island is wiped from the face of the waters. Through the story runs the romance of the light-house keeper's sister and a secret service agent. Hair-breadth escapes—daring rescues—treachery—love. A picture that has rapid action in every scene.

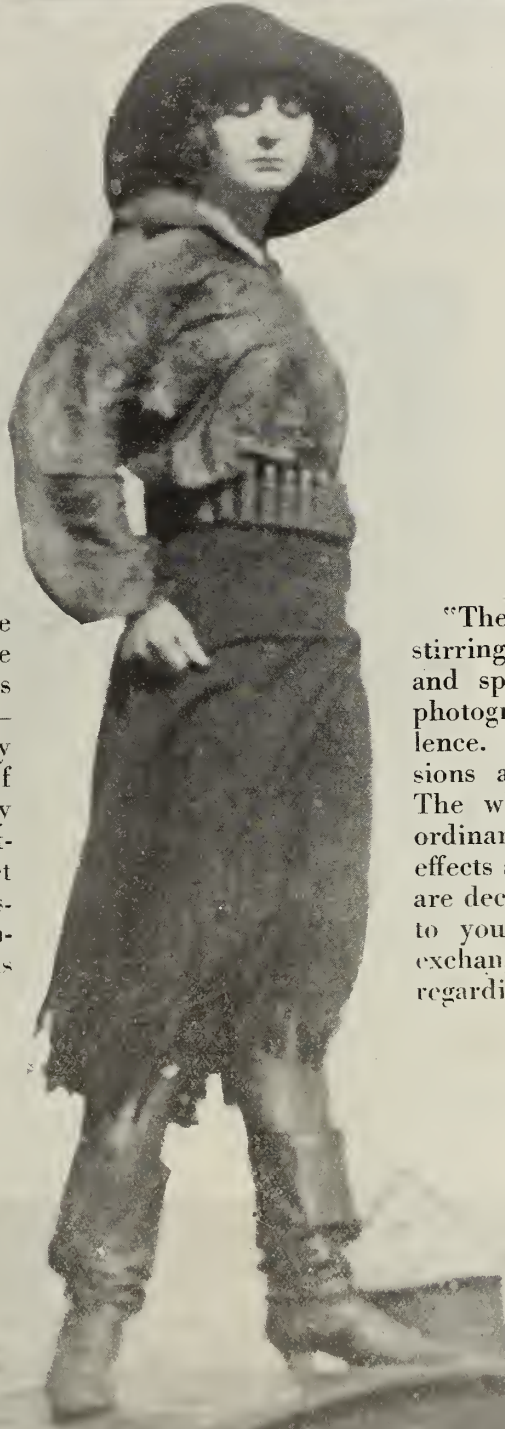

"The Blazing Sea" is in three stirring parts. It is finely acted, and splendidly staged, and the photography is of unusual excellence. The flames and explosions are remarkably realistic. The whole story is out-of-the-ordinary in character and the effects secured in its production are decidedly impressive. Write to your nearest Warner's exchange for full information regarding this picture.

WARNER'S FEATURES, Inc., New York

The ADVENTURES

A great spectacular presentation of James Montgomery Flagg's world-famous series of drawings

JAMES MONTGOMERY FLAGG



The distinguished American Artist whose genius created Kitty Cobb and her startling adventures



MISS MARIAN SWAYNE
Whose charming and refined impersonation of Kitty makes this the most delightful picture ever produced.

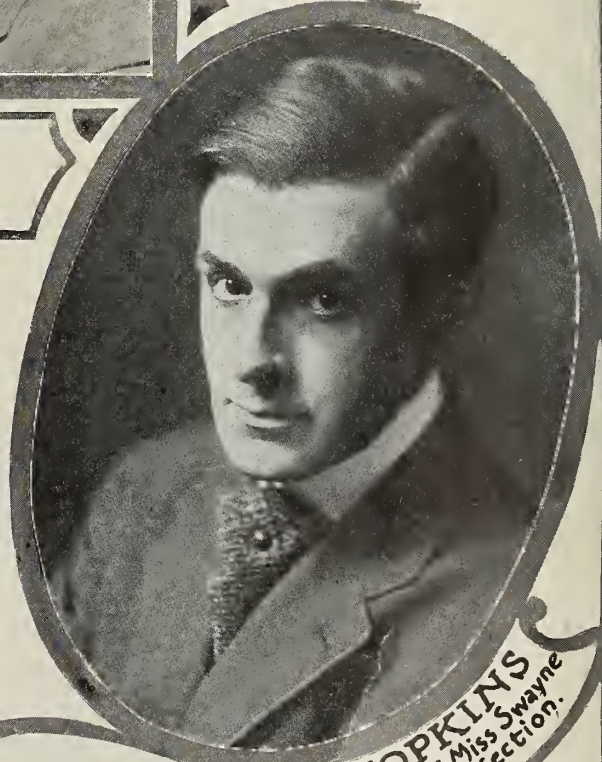

JACK HOPKINS
Whose clever and brilliant support of Miss Swayne contributes to the picture's artistic perfection.

WARNER'S FEATURES, Inc., New York

of KITTY COBB

A wonderful story splendidly produced by a star cast of celebrated motion picture artistes

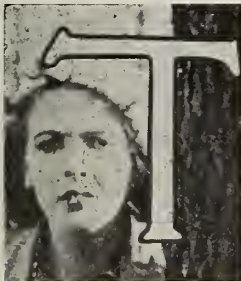

THIS is something big! You know Kitty Cobb, of course. Everybody does. East, West, North and South her fame has spread. She is today the most popular character ever produced by an artist's brush.

James Montgomery Flagg, one of America's foremost illustrators, created Kitty Cobb in a series of great drawings for the New York Sunday *World*. Such a tremendous hit did she make that other big Sunday newspapers clamored for her. So Kitty—sweet, winsome, sunny and brave—was syndicated for the benefit of the whole country, and her start-



ling adventures and charming romance thrilled and delighted an audience that mounted high into the millions.

Now we have Kitty brought to

life—a refreshing, fascinating four-part film which pictures Flagg's famous heroine and her exploits with superb realism. It is truly a marvelous production. Miss Marian Swayne, the



pretty, vivacious little lady who plays the role of Kitty, is exactly suited to it. She gets your sympathies. You laugh with her and cry with her. Your blood boils when she struggles with the kidnappers, and your heart rejoices when love triumphs.

A full line of striking advertising matter, from a display card to a 24-sheet stand in



seven colors. Book this great four-part feature now. Write your nearest Warner's Exchange for full particulars of this release.

It is a wonderful picture with a powerful appeal.



WARNER'S FEATURES, Inc., New York

THE interest taken by Exhibitors in the Complete Service offered by Warner's Features, Inc., is unprecedented. The idea of a 21-reel Weekly Program *plus* big Features *plus* powerful Specials has scored a hit. Advance bookings have been heavy—and they are still coming in. For particulars write to your nearest Warner's Exchange.

Warner's Features, Inc.
New York

Live News of the Week

The Alco Film Corporation is another feature house that is to be added to Pittsburgh's long list. This house has rented headquarters at 212 Fourth avenue, and is getting things shaped up so as to open as soon as possible. A representative of the company was in Pittsburgh several days last week and secured a lease on the property in Fourth avenue in the heart of film row, and it is said the company will be ready to do business here in a few weeks.

Charles Ray, one of the leading men of the New York Motion Picture Corporation, has taken up scenario writing. His first attempt, made more with the idea of filling spare time than anything else, was eagerly seized upon, and Mr. Ray received a substantial check for his efforts. His extensive travels and his ready imagination help him materially in this work.

Harold Lockwood, who appeared as the American business man in the Famous Players picture, "Such a Little Queen," has received many letters congratulating him on his fine portrayal of that character. Mr. Lockwood and Carlyle Blackwell supported Mary Pickford in this picture, and both are remarkably well fitted to their respective roles.

Miriam Nesbit, one of the leading ladies appearing in the Edison films, was recently accorded a royal reception on her arrival at Lake Hopatcong, N. J. A dance was given in her honor and her many admirers showered her with congratulations for the many fine characterizations she has displayed in the Edison pictures.

Vivian Rich, leading lady of the American Film Company, has taken to writing scenarios for the Beauty Company. Harry Pollard, director of the Beauty productions, has just finished her first work, entitled "Nieda."

Hudson Maxim, the inventor of machine guns and high-power explosives, was an interested observer when T. Hayes Hunter, director of the Colonial Motion Picture Company, directed the battle scenes of "Seats of the Mighty," at Edgewater, N. J., recently. Seated in his car out of the firing line, and likewise the camera line, Mr. Maxim watched the proceedings with great interest.

Vivian Martin, one of the most fascinating ingenues of the stage, has been signed by the Peerless Feature Producing Company, to star in the forthcoming release based on Owen Davis' "The Wishing Ring."

This play was the vehicle Marguerite Clark used in making her entrance into the field of the legitimate theater. "The Wishing Ring" is one of three plays written by Owen Davis that have been

Edwin August, of the Eaco Films, nearly lost his life while a scene from "Below the Deadline" was being filmed on the roof of the World Tower Building, New York City. Mr. August lost his footing while on the edge of the roof, and only great presence of mind on his own part saved him from falling to the street below.

The Princess Theatre, Sturgis, Ky., has installed a new electric player piano as an additional attraction for its patrons. A five-reel program is given and a full house is usually enjoyed at five and ten-cent admissions.

Sol Lesser, president and general manager of the Golden Gate Film Exchange, spent a few days recently with Manager Emmick at the Los Angeles exchange.

Announcements will be made in the future of a complete program to be served by this and the San Francisco exchange in addition to the feature programs that have been handled in the past.

Arthur Bard, manager of the booking department of the California Film Exchange, Inc., of 742 South Olive street, Los Angeles, is again at the exchange after a vacation of a week spent at the summer resort at Murietta Springs, Cal.

The Woodley Theater, Los Angeles, has entered into a contract with the World Film Corporation to show its features. The Woodley has been using the General Film service.

Robert A. Brackett has resigned as manager of Clune's Broadway Theater, Los Angeles, to take charge of a feature picture put out by the Historical Picture Company of Chicago, showing Buffalo Bill and General Nelson A. Miles in the Indian Wars. Mr. Brackett has been identified with the exhibition of feature pictures for a number of years, serving as manager for the Lyman H. Howe travel pictures, the Archie L. Shepard attractions, and the O. T. Crawford Film Exchange, of St. Louis.

Harry C. Drum, general representative of the World Film Corporation, has closed contracts with all the Princess houses in Colorado and Utah, to show the Shubert and Brady releases of the concern.



VIVIAN MARTIN

purchased by the Peerless Features Company for motion pictures.

The other two were "Lola," in which Clara Kimball Young is to be starred, and "A Marked Woman," in which Barbara Tennant is to play the title role. All these features are to be released through the World Firm Corporation.

Bryant Washburn, heavy lead in the Essanay company, recently received a gift of a prize bull pup from a fair admirer. He says that the canine gives him more trouble than several families would.

Ted L. Bargman, of the Golden Gate Film Exchange, was recently in Los Angeles, after a successful three weeks' trip with "The Spoilers." He is now on a trip north of Los Angeles with the same picture.

The accompanying illustration shows Dustin Farnum with his horse Monte, which the actor used at the Hollywood (Cal.) studio of the Universal Com-



DUSTIN FARNUM AND HIS HORSE.

pany, in the film version of "The Virginian," which is now at the beginning of what promises to be an unusually successful run throughout the country.

T. Harry Oliver, formerly secretary and treasurer of the Luckens Film Company, of Philadelphia, is now manager of the Noted Plays Feature Company, located at 400 Ferry street, Pittsburgh. The local company will handle the productions of the Life Photo Firm Corporation and other high-grade features.

In the two-reel production, "The Real Agatha," to be released shortly by the Essanay Company, Richard Travers, the leading man, was called upon to save two of the extra girls from drowning. They were precipitated from a canoe, for the camera, and Mr. Travers, played the hero, and rescued them, but he was the hero in reality also, as both the young women were on the point of sinking.

Charles K. Field, editor of the Sunset Magazine; Robert G. Fowler, an aviator; Riley Scott, a magazine writer, and Ray A. Duhem, a motion picture photographer, all of San Francisco, are held in that city, pending an investigation of the Federal Courts, of their action of taking and exhibiting pictures of the Panama Canal fortifications.

Aviator Fowler testified that he had received permission from Colonel Goethals to fly over the canal, with Duhem, who took the pictures. This was before the order was issued forbidding the taking of pictures of the fortifications. The other men had written articles on the subject.

Captain Wilbert Melville, manager of the Lubin Los Angeles studios, is now on a vacation at the Philadelphia studios. This is the first visit that the captain has made to the eastern studios in over a year. Three able directors are caring for his work in his absence.

Ruth Hartman, formerly of the Vitagraph and Kalem companies, has been engaged by the Favorite Players company to play opposite Carlyle Blackwell in "The Man Who Could Not Lose." The story of this picture was written by Richard Harding Davis and adapted for the screen by Robert A. Dillon.

WILL RELEASE THROUGH ALCO

The B. A. Rolfe Photo Play Company, a new firm, will produce for the Alco Film Corporation exclusively.

B. A. Rolfe will be remembered by vaudeville patrons for his "Colonial Septette," "The Bride Shop" "Lonesome Daisies," and many others.

Alco has also made a contract with Grombacher and Bailey to act as their exclusive agents for the states of Washington, Oregon, Montana and Idaho. The new alliance will be known as the Alco Film Service, which has opened offices in Seattle and Spokane, Wash., Portland, Ore., and Butte, Mont.

Sol Lesser, a prominent exchange man of the Pacific Coast, signed a contract with Walter Hoff Seely, president of the Alco, for the state rights of all the Alco releases for California, Nevada and Arizona.

Mr. Lesser will be the general manager of the exchanges in the above-mentioned states, with headquarters at 234 Eddy street, San Francisco.

PROF. GILLETT DEAD

Prof. William Kendall Gillett, professor of romance languages at New York University since 1890, an uncle of E. Kendall Gillett, secretary of the Exhibitors' Times, Inc., the company publishing THE MOTION PICTURE NEWS, died September 28, at Mount Sinai Hospital, New York City, in his fifty-fifth year. Prof. Gillett was graduated from New York University in 1880 with the degree of A. B., and three years later was made an A. M.

During 1889 and 1890 he attended the University of Paris and studied languages in Paris, Geneva, Florence, Madrid and Seville. From 1885 until 1888 he was instructor in languages at Lehigh University, and in 1890 joined the Faculty of New York University. Prof. Gillett was secretary of the Faculty from 1891 until 1898, and was chairman of the committee on college organizations from 1902 until 1907.

Prof. Gillett was a member of the Modern Languages Association of America and the Delta Phi fraternity. He was also a member of the New York Athletic, the Wykagyl Country and the Century clubs.

COAST THEATRE FIRM FORMS EXCHANGE

The Clune Amusement Company, owners of three theaters in Los Angeles and one in Pasadena, Cal., are gradually growing into a feature film exchange. They have purchased the State rights of California, Arizona and Nevada, for a number of features, including "The Escape," and "Sealed Orders." W. H. Clune, president of the company, formerly conducted a film exchange in Los Angeles which was sold to the General Film Company.

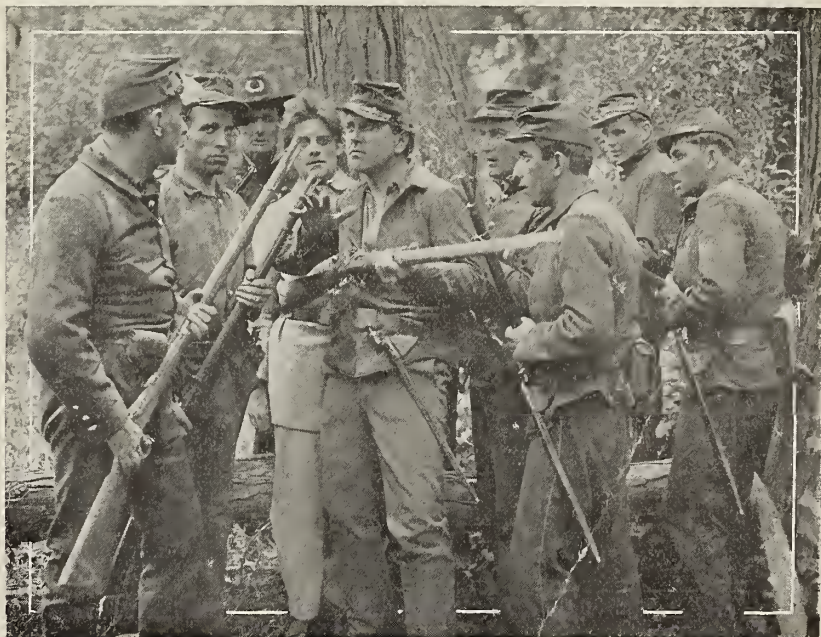

SCENE FROM "HIS BROTHER BILL"
(Lubin—Two Reels—September 30)

ALLIANCE FILMS ANNOUNCES POLICY

Corporation Proposes to Eliminate State Rights Sales—Plan Is Practically a Co-operative One—Manufacturer's Profits Derived from a Percentage of the Bookings—A Rotating Committee Will Pass Upon Pictures—Only Best Productions Handled by the Company

THE announcement of the Alliance Films Corporation will cause much surprise in film circles. This company is offering a new program of multiple reel features to be released weekly. George West, of West Brothers Knitting Company, Syracuse, N. Y., is the president, and Andrew J. Cobe is the vice-president and general manager.

"The Alliance proposition is practically a co-operative one," said Mr. Cobe, "and brings the manufacturer very close to the exhibitor. It eliminates entirely the sale of state rights, and makes each manufacturer back up his own product.

"Under the state right plan a manufacturer necessarily hesitates in spending large amounts upon production, for there is no assured market. Furthermore, the manufacturer's sole idea is to dispose of the territory.

"With the Alliance plan the manufacturer cannot make any money unless his film can earn it, for his profits are entirely derived from a percentage of the booking. None of the manufacturers are interested in the exchanges, and the Alliance cannot, therefore, be influenced to release a picture that is not of the highest grade.

"A rotating committee appointed by the exchanges passes upon the films, and the exchanges know in advance the quality of the films they will handle.

"The manufacturers affiliated with the Alliance Films Corporation have splendid organizations, and the photography, acting and direction will always be of the highest class. Only subjects of great drawing power are being selected for dramatization.

"We have not made an announcement of the exchanges handling the Alliance program for the reason that actual contracts have not yet been signed with a few of them, but within a week all arrangements will have been concluded. When the list is published it will be seen that the names will include the highest class renters of the country. No statement will be made by the Alliance which is not an assured fact, backed by contracts duly signed and sealed.

"For the same reason we are not announcing the names of the other manufacturers who will be affiliated with us, and while negotiations have been concluded and we would be warranted in publishing such information, the actual contracts have not yet been signed," Mr. Cobe continued, with earnest emphasis. "There are many high-class theatres

program' in our entire organization. Every manufacturer must continually strive for quality. A franchise in the Alliance does not mean that a producer who is fortunate enough to get in can turn out footage to carry out the terms of his contract, but he must produce real features. And our standard is high," concluded General Manager Cobe.

M. H. Blackwell, treasurer of the Favorite Players Film Company, Inc., was also highly pleased with the Alliance plan of operation, saying:

"Our policy is to produce films from well-known books. Our first release, 'The Key to Yesterday,' will explain clearly what we consider a good film. The Alliance plan gives us an interest in our films when they are being shown in the theatres, and you can rest assured that we are as anxious as anybody to make money and that we will leave no stone unturned to make such pictures as will make the exhibitor our friend."

William H. Wright, treasurer of the Excelsior Film Company, expressed his pleasure in being affiliated with the Alliance Films Corporation, and said:

"The Alliance and its methods of marketing the film strongly appeals to us. We have confidence in our organization and the plans we have laid for the future, and we feel sure that we will meet with great success. We shall specialize in popular books, with film stars."

Here Mr. Wright went into details as to releases.

"Our first release in the Alliance Program is 'The Path Forbidden,' by John B. Hymer, featuring Octavia Handworth. We believe this film will cause a sensation, as startling effects are produced.

"Miss Handworth plays the dual role of the twin sisters and is seen crossing from one side of the stage to the other, meeting herself and handing various articles to herself. This work had to be timed to the thousandth part of a second, and I do not know of its having ever been successfully accomplished before.



ANDREW J. COBE
Vice-President and General Manager of Alliance Films Corporation

which would gladly pay a fair price for big feature productions, but which have been unable to secure a dependable supply from week to week. These exhibitors know the great disappointment caused by booking a widely-advertised feature and to discover that on the screen it is but a mediocre subject.

"Before the Alliance advertises the subject it will have been run off and passed upon by the exchanges which will handle it, and with the class of exchange men handling the Alliance program there is no doubt that they know a good film when they see it.

"There is not an element of 'forced

"Our next release is 'When Fate Leads Trump,' another picturization of a well-known book. We have several other subjects completely finished and ready for release, which will be duly announced.

"The state right proposition does not appeal to me for the reason that we have gone to great expense in making our films, and we feel sure that they are going to be highly successful. We are more than willing to take a chance with the exhibitor, and can confidently promise superior film productions. This Alliance plan is not a get-rich-quick stock jobbing proposition, and every man in it must earn the money he makes."

S. G. Lindeman, treasurer of the Select Photoplay Producing Company, Inc., commented on the Alliance announcement in the following manner:

"We are in hearty accord with the ideas of the Alliance Films Corporation, and are willing to put the test of our product up to the exhibitor. A man who sincerely desires to make good film cannot find a flaw in the arrangement.

List of Exchanges to Come

"The Alliance will put out our first picture, 'At the Old Cross Roads,' from which we expect great results. Arthur C. Aiston, the owner of the play, sent it out on the road for fourteen consecutive seasons and it always played to tremendous business, repeatedly breaking box office records.

"Many people have pronounced our film version of this play much more powerful than the legitimate drama, as all detail is clearly shown. However, we will be satisfied if it does as well as the original play, and we feel sure that every moving picture house that shows this subject will be more than satisfied.

"We shall continue making well-known plays, and as far as possible will present the original stars. In 'At the Old Cross Roads' Estha Williams has her original role of 'Parepa.'"

While the list of exchanges has not yet been made public, when the announcement is made it will be seen that P. P. Craft, the well-known film man, has secured franchises for three offices.

Mr. Craft says that the Alliance plan is the fairest proposition he has ever encountered in the history of the film business, and is very enthusiastic.

"I have dreamed many times of such a condition," said Mr. Craft, "but I never expected to find manufacturers broad-minded enough to enter into such an arrangement. As far as the exchanges are concerned, I think that any man securing a franchise should thank his lucky stars, and should be moved to work with might and main to make successful the finest proposition ever launched."

GERBER HANDLES BOX OFFICE

Roy Gerber, who has charge of the films at the Box Office Attractions company, in Pittsburgh, is a young man of extensive experience. He received his training with the Kleine company.

Washington Ball Advertised in Slides

Forty Theatres Show Same Announcement at Once—Weekly Change, Unfolding Attractions of Reception, Until Last Day

Special to THE MOTION PICTURE NEWS

Washington, D. C., Sept. 30.

JUST at present the Motion Picture Exhibitors' League of the District of Columbia is bending all its efforts towards the reception and dance that it will give at Convention Hall on October 31.

This will be the first time anything of the kind has been offered to the public of the national capital, and everyone is interested. The chief aim of this dance is to boost the motion picture industry here as well as to offer the opportunity to the enthusiasts of Washington of meeting a number of the photoplayers who are daily admired on the screen, and to add to the finances of the league.

A novelty for creating curiosity and interest in this event is being put forth in a series of slides, which are being run on at least forty screens.

These will be changed weekly, each unfolding more and more the attractions of the dance and reception. The first of the slides which have thus far occupied the screens is the following:

SATURDAY, OCTOBER 31.

(Hallowe'en)

WHAT?

WHERE?

WATCH!!!

This was followed by another:

SATURDAY, OCTOBER 31.

(Hallowe'en)

SEE THEM!

MEET THEM!!

TALK TO THEM!!!

WHO?

YOUR FAVORITE PHOTOPLAY STARS.

WATCH THIS SCREEN AND THE WASHINGTON POST FOR FURTHER ANNOUNCEMENTS.

The Washington Post has donated \$1,500 of advertisement to be used at the discretion of the publicity committee. By this means the subject is being daily brought before the people. Interviewing Fulton Bralawski, chairman of publicity, he made these statements:

"The league has arranged to have about fifty photoplayers from various companies to meet and give short talks to the people between dances.

"In order to put the price of admission within the reach of everyone, especially the younger circles, tickets will be one dollar. Arrangements have been made for the elaborate decoration of Convention Hall and an orchestra of fifty pieces will furnish the music.

"Even at this early date the Exhibitors' League of the District of Columbia has received much encouragement for the success of this reception and dance." THEODORE FRANKLIN.

New York Suburbanites See Themselves in Films

"Oh, Would Some Power the Giftie Gie Us to See Oursel's as Others See Us" Comes True at the Newell

Special to THE MOTION PICTURE NEWS

White Plains, N. Y., Sept. 30.

MOTION pictures of White Plains, taken by the Gotham Film Company, were recently shown at Newell's theatre. Crowded houses saw the pictures, and they were of more than ordinary interest, for many in the audience saw themselves as others see them, in films.

This was the first time that a motion picture showing exclusively people and views of this village has been shown here, and when the idea was presented to him, Manager Newell immediately accepted, as he knew that it would be of interest to local people generally. That it proved to be so was evidenced by the many who attended.

The picture was in one reel and took about twenty-five minutes to run. Frequently when a picture was shown there were bursts of applause, as was the case when the picture of Village President-elect John J. Brown and Sheriff William J. Dolve were shown on the theatre screen.

The first picture shown was that of John J. Brown, Manager Newell and Dr. James A. Boon in front of the Keeley Institute. It showed the three men shaking hands and separating, and

then a picture of Mr. Brown was shown standing alone.

A drill at St. John's School, with the St. John's Fife, Drum and Bugle Corps playing while the children filed out was shown, and it was very clear and showed the pupils to advantage.

WANT PREMIUM REDUCED

At a meeting held in the office of the Workmen's Compensation Commission, 151 William street, New York City, on September 29, A. Winburg, of the Famous Players' Film Company, and Carl Anderson, of the Jesse L. Lasky Feature Play Company, requested a ruling by the commission whereby actors would be divided into two classes.

It was maintained by the film representatives that a distinction should be made between players who acted in studios and those appearing in screen productions staged outdoors. The first, it was declared, should be classed with those of the regular stage.

The insurance rate set by the commission for motion picture actors is \$4.05, and for legitimate players, 55 cents.

The commission took the matter under consideration.

"AN AMERICAN HEIRESS" FULL OF POWER

THIS is another dramatic episode in Emmett Campbell Hall's interesting narrative of the adventures of Lord Cecil, in the series entitled "The Beloved Adventurer." Depleted fortune demands a heroic effort to save his estate from foreclosure of the mortgage, and Cecil promises his creditors that he will marry an heiress. With this intent he goes to America and is warmly welcomed by the family of a peanut butter king, with millions.



SCENE FROM "AN AMERICAN HEIRESS"
("Beloved Adventurer"—Part Five)

The beautiful daughter and only child is quickly offered and Cecil is satisfied that she will quite do, until he discovers that the girl is deeply in love with a poor but worthy young American.

Cecil's heart goes out to the young couple, and seeing no other way to avoid the pressure put upon the girl, he resolves to abduct her. This he does and safely places her in the arms of her lover, thus making two lives happy, while he returns penniless, back to face the inevitable loss of his beloved Crotleigh. In this Arthur Johnson agains excels.

FAMOUS PLAYERS CONTROLS CELEBRATED NOVELS AND DRAMAS

THE Famous Players' Film Company, which two years ago secured the fiction and dramatic masterpieces of Anthony Hope, Thomas Hardy, Mrs. Frances Hodgson Burnett, C. H. S. McClellan, and Louis Joseph Vance, and has since continually added other illustrious literary names to its list, now controls the film rights of a formidable array of the foremost novelists and dramatists of the day.

This brilliant galaxy of literary celebrities now includes Henry Arthur Jones, Hall Caine, Margaret Mayo, H. A. Du Souchet, Mary Johnston, Channing Pollock, George Ade, Booth Tarkington, William J. Locke, Mark Lee Luther, C. Haddon Chambers, Sir Charles L. Young, Maurice Hewlett, A. C. Gunter, George Horace Lorimer, John Luther Long, Clyde Fitch, Bronson Howard, Angel Guimera, and Margaret Deland.

BUFFALO FILMS VERSUS "LEGITIMATE"

Special to THE MOTION PICTURE NEWS

Buffalo, N. Y., Sept. 30.

MOTION pictures were never more popular in Buffalo than they are at present.

The announcement of the coming big legitimate show is now creating the interest which it did last year and the year before. The prices of \$1.50 and \$2 do not appeal to many Buffalonians under present conditions and the photoplay theatres are reaping the benefit.

NORTH YAKIMA BANS WAR FILMS

Special to THE MOTION PICTURE NEWS

Spokane, Wash, Sept. 28.

THE city of North Yakima, near here, has placed the ban on all motion pictures dealing with any phase of the war in Europe.

As was the case when a similar order was issued by Mayor W. J. Hindley here, it is unlikely that the matter will be carried into the courts.

**Get Your Patrons
"In The Habit"**

--of coming to your door each day by showing them pictures of brilliant detail and clearness. This is best done by using

**Bausch and Lomb
Projection Lenses**

Bausch & Lomb objectives show every detail in the film to wonderful advantage. Brilliant illumination and a true contrast between black and white are also characteristic. Ask your operator.

Regularly supplied with Edison and Nicholas Power machines and procurable at all exchanges.

Send for our interesting free booklet for owners and operators.

Bausch & Lomb Optical Co.
569 ST. PAUL STREET ROCHESTER, N.Y.



E. & W. TRANSFILM BUREAU

(ESTABLISHED 1913)

220 WEST 42d STREET, NEW YORK CITY

GENERAL AGENTS

SINGLE REEL COMEDIES

We offer for sale on territorial rights four excellent Fred Mace comedies; his latest efforts.

FOUR BIG FEATURES

We have ready for the market negatives, world rights, on four AMERICAN features of four reels each. The "leads" are by well-known stars.

WE WILL BUY

New or second-hand films, copies or negatives. The highest prices paid for good stuff.

E. & W. CIRCUIT

We are prepared to book big feature productions over our circuit in the New England States and New York and Pennsylvania.

STATE RIGHT BUYERS SHOULD COMMUNICATE WITH US

Telephone Bryant 3914

FRED R. JONES, General Manager

CHAS. C. O'HARA, Asst. General Manager.



INTERESTING FILM REVIEWS

PRODUCTIONS FROM ALL PROGRAMS

GENERAL FILM PROGRAM

"A First Class Cook." (Biograph. Mon., Sept. 28.)—On the same reel with "The White Hand Society." An extreme example of the throw-things-around type of comedy, but rather funny in spots. The cook's methods of preparing food are most extraordinary.

"The White Hand Society." (Biograph. Mon., Sept. 28.)—On the same reel with "A First Class Cook." It is an entertaining burlesque of the heavy Black Hand melodrama, and as such is a success. The ladies of the white hand society are shown at their tricks.

"The Viper." (Kalem. Two reels. Mon., Sept. 28.)—Alice Joyce is featured in this melodrama. A girl marries against her father's wishes, but is forgiven. Her husband is ruined by prosperity and becomes a drunken brute. He is supposed to have died in a fire on a gambling houseboat. His unsuccessful rival marries the girl. The husband turns up unexpectedly but meets a most timely death as a result of treachery to those who had befriended him. Good settings and excellent acting.

"When the Gods Forgive." (Vitagraph. Mon., Sept. 28.)—A fairly good western picture. A trapper ill-treats his Indian wife and as a result is to be burned at the stake. A rain saved his life and leads to his reformation. Margaret Gibson and George Holt head the cast.

"The Case of the Vanished Bonds." (Edison. Sat., Oct. 17.)—A clever detective play, full of mystery and adventure, adapted from "Below the Deadline" by Scott Campbell. The unfolding of the method of the robbers is skilfully manipulated. Bigelow Cooper, Frank McGlynn, Yale Benner and Ben West are cast in the important parts.

"Two's Company." (Edison. Wed., Oct. 21.)—First rate comedy in Mark Swan's most engaging way of keeping one laughing from beginning to end. A young lady and gentleman are courting, and they wish to be alone. Unfortunately the lady's family is a large one, and they can never get rid of one member or another of the brood. They try almost everything but each time they fail to get the solitude that they so much desire. Finally in dire distress they make an ascent in a balloon, and the moon comes out to smile upon them.

"For Love of Him." (Selig. Tues., Sept. 22.)—An actress jealous of a rival in love and in her profession puts acid in her face cream to spoil the other woman's beauty. The plot is frustrated by accident, and the repentant actress gives up thoughts of vengeance. In the cast are Adele Lane, William Stowell and Edith Johnson.

"Merely Mother." (Biograph. Two reels. Tues., Sept. 15.)—A typical Biograph drama made in the Biograph manner. It is rich in sentiment and will make a distinct impression upon the great mass of motion picture devotees. The story with plenty of heart interest never becomes maudlin. A girl has been put through school by the unselfish efforts of her mother and when she marries a wealthy man, she ignores her poor mother altogether. When the husband realizes that his wife is neglecting their child for the sake of pleasure, he grieved, but when he sees the heartless way in which she treats her mother, he is driven to the point of desperation. The child proves irresistible to the older people, and will prove irresistible to the audience, and love comes back to a loveless home.

"The Way of His Father." (Essanay. Tues., Sept. 15.)—The eternal rebellion of the young against following in the footsteps of those who have preceded, the striving to reach out into new fields is the theme of this drama that is adapted from one of the Munsey magazines.

The father, a physician, desires his son to

carry on his practice in the little home town after he completes his course. The son gets a chance to step into a field that offers greater opportunities and decides to leave home. The father falls ill of a broken heart. The boy then sacrifices his own future to comply with his father's wishes. Richard C. Travers, Thomas Cummford and Bryant Washburn play the leading roles.

"Barry O'Moore." (Kalem. Reissue. Sat., Sept. 26.)—This picture, filmed in Ireland, presents an excellent story. The cast is headed by Gene Gauntier. The toils and troubles that Barry O'Moore experienced at the period when all Irish patriots were considered outlaws by the English are portrayed. He is always aided by his sweetheart and at length the two escape to America. The priest giving up his life for the patriot is a strong point.

"The Gold Thief." (Biograph. Sat., Sept. 26.)—It is rather improbable that a gold worker should be able to conceal gold dust in his beard, but such is the case here and he is finally discovered by a detective. The love story is a little weak. It is interesting to watch the detective working on the case.

"Hearts and Diamonds." (Vitagraph. Two reels. Sat., Sept. 26.)—Flora is extremely fond of baseball players, and Bunny, to win her hand, takes up the game himself. The game will furnish a lot of amusement. Strictly speaking, the story is not a two-reel subject, but it is laughable all the way through.

"The Lost Mail Sack." (Kalem. Two parts. Mon., Oct. 7.)—Another railroad drama that manages to maintain interest in spite of crudities in construction. There are two distinct plots and the author has not managed to keep them distinct in the mind of the spectator and to connect them properly in the climaxes. G. A. Williams, Helen Holmes, Jane Wolfe, A. E. Hammond, and Bert Hadley do the best they can to overcome these difficulties.

"A Double Error." (Vitagraph. Wed., Sept. 23.)—Jimmy Morrison and Dorothy Kelly, together with Lillian Burns and George Cooper, inject plenty of life into this lively comedy of errors. A brother and sister pretend to be married and when they fall in love they have their troubles.

"The Samaritan Who Got Paralysis of the Helping Hand." (Essanay. Wed., Sept. 23.)—Another of George Ade's series of fables. A man gives his money indiscriminately to panhandlers, but when he attempts to fix up a lover's quarrel he has trouble. In the cast are Thomas Commerford, Florida Kingsley, Harry Dunkinson and Helen Dunbar.

"A Just Punishment." (Selig. Wed., Sept. 23.)—A financier learning that his nephew is in a shady mining deal attempts to reform him. The nephew and his wife attempt to kill him by gas, but he escapes. He disinherits them. A straight melodrama. In the cast are Guy Oliver, Jack McDonald and Eugenie Besserer.

"Jimmie, the Porter." (Selig. Split reel. Fri., Oct. 9.)—This is a good piece of comedy business, not overdone. Jimmie is not the favored suitor, but decides to win out. His rival has the inside track, so Jimmie decides to act as porter. Jimmie wins. On the same reel with "Doc Yak's Bottle."

"Her Victory Eternal." (Selig. Sat., Oct. 10.)—Some of the finest emotional acting that has been done for some time is seen in this picture. Eugenie Besserer in the role of Mrs. Tabor plays the part very convincingly. The story has a strong heart appeal and is well acted.

"The Real Agatha." (Essanay. Two reels. Fri., Oct. 9.)—A picture with a series of incidents that leads to the obvious climax. The

entire production is carried on the shoulders of the players whose acting is very good. Richard Travers, Ruth Stonehouse, Oscar Briggs and Helen Dunbar play the leads.

"Toys of Fate." (Lubin. Two reels. Wed., Sept. 23.)—An Italian immigrant is shanghaied, and his wife and child left in the streets immediately after arriving in this country. The wife dies and the little girl is adopted. The Italian vows to kill the man who shanghaied him. When he has a chance he finds that his wife has cared for his daughter all that time. He saves the man who had wronged him, his wife and his own daughter, but dies in doing so. In the cast are Velma Whitman, Julia Scott, W. E. Parsons, George Routh, L. C. Shumway and Melvin Mayo.

"For the Love of Mike." (Kalem. Split reel. Tues., Oct. 6.)—Mike is a fat policeman that all the women go wild over. They neglect their best fellows altogether and scrap among themselves to be the apple of the darling cop's eye. The consequence is all arrested, and penitently asked forgiveness of their beaux when Mike's large family troops into the station house. This is the larger part of the reel which also has "Hesanut Hunt's Wild Game."

"Hesanut Hunts Wild Game." (Kalem. Split reel. Tues., Oct. 6.)—These extremely comical cartoons afford the merriest sort of fun. How the strange looking creature hunts tigers, lions, elephants and cannibals is delightfully whimsical and amusing. On the same reel with "For the Love of Mike."

"A Fragment of Ash." (Edison. Sat., Oct. 10.)—Entertaining play of a necklace robbery in high society, committed by one of the charmed inner circle. He is detected by the cigarette ash which he leaves in the case with the paste necklace. The only questionable thing about the picture is whether cigarette ashes can be so distinctive as to lead to the capture of a thief. Mrs. Wallace Erskine, Laura Lyman, Robert Conness and Duncan MacRae play the main parts.

"Seth's Sweetheart." (Edison. Wed., Oct. 7.)—Pleasing and diverting comedy of rural life from the pen of J. Edward Hungerford. The country girl is carried away by the courtly manners of the city fellows that come for the summer, but the faithful country lover wins out in the end.

"The Way of the Redman." (Selig. Tues., Oct. 6.)—A very good Indian story with Tom Mix as the Indian. He befriends a gambler, who in turn steals his wife from him and mistreats her. The redman returns to his forefather's idea of punishment and ties the gambler to a stake and places food just out of reach. When, through the little girl, the gambler attempts to escape there is a death struggle between Indian and white man.

"The Reparation." (Selig. Wed., Oct. 7.)—An interesting story of the South during the period of the Civil War with several strong situations. A story where a man's better nature is brought to the surface only by the sacrifice of another life.

"The Mexican." (Selig. Oct. 13.)—In order to keep his family from starving, a Mexican secures work on a ranch where his breed is not popular. He is persecuted until he tries to kill his foreman. He decides to burn the ranch, but instead hurries for a doctor for the rancher's daughter, who has been bitten by a snake. As he rides by in breakneck speed he is shot at by the foreman. He saves the baby and is rewarded. A good story well played.

"The Mio Hater." (Selig. Oct. 16.)—A farce comedy with Lillian Brown Leighton in the leading role. She hates men until she finds a man that hates women, so they decide not to be any more, with the result that her name Betty can marry; and the boys

about the ranch do not have to listen to any more of the foreman's harsh talk against women. A good comedy well laid out.

"The Woman of It." (Selig. Oct. 17.)—An old story with a good cast, including Kathlyn Williams, Wheeler Oakman and Charles Clary. These trio of players are stranded so long on an island that the primitive in them reasserts itself. The brute wins the woman's love. When help arrives she refuses to return to civilization, preferring the wild life with the brute.

"The Wrecked Special." (Kleine. Two reels. Oct. 6.)—A very strong story of love and duty with reparation at the end. Another man serves a prison sentence for the doings of the other, who, to save the life of his daughter, wrecks a train. He returns to his country to find that his friend is serving a sentence for his deed. Their children love. He confesses and is found not guilty.

"The Dream Girl." (Selig. Two reels. Oct. 12.)—Bessie Eyton and Thomas Santschi are featured in this production. It is a good story well played. A young artist has a dream of a pretty girl who becomes his ideal. He thinks of and paints the face so often that he believes there must really be a flesh and blood person such as the portrait. His search is rewarded with many adventures and the girl of his dreams.

"The Mysterious Beauty." (Selig. Oct. 14.)—A farce comedy with a number of novel situations. Harold Heath, a wealthy young clubman, dreams of a beautiful girl. He awakens and sees her counterpart walking past the club window. He follows, is kidnapped, plays waiter, loses a tooth and his confidence. Swears "never again" when the girl is arrested, only to turn around and follow another pretty girl.

"The Tattered Duke." (Kalem. Fri., Oct. 9.)—The Duke of Tattenham Corner loses his money and the waiter who finds it passes himself off as His Grace for three days. His awakening is a rude one as is that of an ambitious mamma. The cast includes Marshal Neilan, Lloyd V. Hamilton, Alice West and Ruth Roland.

"The Fall of Muscle Bound Hicks." (Biograph. Thurs., Sept. 24.)—On the same reel with "The Plumber's Picnic." It is a fairly entertaining comedy of the slapstick class.

"The Plumber's Picnic." (Biograph. Thurs., Sept. 24.)—This is the short end of the same reel which has "The Fall of Muscle Bound Hicks." It is a comedy of a similar type. The fun is rather strained at in spots.

"The Triumph of Right." (Lubin. Two reels. Thurs., Sept. 24.)—This is the old story of a man who is arrested for a murder committed by a burglar because he is known to be an enemy of the man killed. In this case the victim escapes on the way to the penitentiary and after three years his wife succeeds in clearing him, and they are reunited. Lillie Leslie and William Cohill are the principals.

"A Close Call." (Vitagraph. Thurs., Sept. 24.)—A robber hides his loot in the cabin of an innocent pioneer. The owner of the place is arrested, while the guilty man keeps his wife silent by a threat to kill her child. Later the woman slips a lariat around him and sends for the sheriff. In the cast are Frank O'Neil, Lillian Walker, Audrey Berry and Nicholas Dunaew.

"Slippery Slim and the Green-Eyed Monster." (Essanay. Thurs., Sept. 24.)—Sophie sends word to Mustang Pete that her father has retired early and he can call. Slim is jealous and goes to Sophie's home. He arouses the "old man" and trouble follows. Victor Porel, Harry Todd, Margaret Joslin and Ernest Van Pelt compose the cast.

"The Moving Picture Cowboy." (Selig. Two reels. Mon., Oct. 5.)—A western picture with plenty of good humor and comic situations. A motion picture actor departs for the West where he boasts of his feats of horsemanship. The way he actually did these stunts is laughable. Tom Mix plays the lead well.

"The Strategy of Broncho Billy's Sweetheart." (Essanay. Sat., Sept., 26.)—Marguerite Clayton, as Billy's sweetheart, saves him from the sheriff's posse, who are after him through a mistake. This makes a fair story for those who appreciate this variety of

Western. As usual, the riding is the most prominent feature and G. M. Anderson has a chance to display his ability in this line.

"The Newsboy Tenor." (Selig. Sat., Sept. 26.)—The story here is not quite strong enough to cause the interest to be aroused. The loss of the widow's child and then his reappearance warms her second husband's heart towards children. A good fire scene is registered.

"Did He Save Her?" (Lubin. Split reel. Sat., Sept. 26.)—On the same reel with "Between One and Two." Rather poor comedy. To win the girl he loves the young man throws water on her aunt while she is asleep on the beach, then wakes her, and pretends to have saved her from drowning.

"Between One and Two." (Lubin. Split reel. Sat., Sept. 26.)—On the same reel with "Did He Save Her?" Quite a bit of amusement is furnished by this comedy. The story is woven around the antics of a drunkard and his more sober friend.

"Buster Brown's Uncle." (Edison. Sat., Sept. 24.)—On the same reel with "A Question of Clothes." Buster's uncle arrives for a visit and his lively young nephew keeps things going at a fast but uncomfortable pace for the old gentleman.

"A Question of Clothes." (Edison. Sat., Sept. 24.)—This is the familiar story of a man who has his clothes stolen by a tramp while he is in bathing. He is arrested as a tramp. It is on the same reel with "Buster Brown's Uncle."

"Wood B. Wedd and the Microbes." (Edison. Mon., Sept. 26.)—The eleventh of the series in which Wood B. Wedd continues to justify his name. In this reel he encounters a woman who fears microbes and dotes on eugenics. The satire is excellent. There is the usual cast for this series.

"The Mystery of the Sealed Art Gallery." (Edison. Tues., Sept. 27.)—The twelfth of the "Chronicles of Cleek," featuring Ben Wilson. A stolen necklace is recovered and the guilty person found to be a nephew of the owner, who pretends to be blind. The work of the detective is a trifle obscure.

"A Horseshoe—For Luck." (Vitagraph. Fri., Sept. 25.)—A man picks up a horseshoe for luck and is immediately plunged into a series of disasters. When he puts the horseshoe into a boxing glove he knocks out an opponent of much greater powers. Sidney Drew, Kate Price, Mary Anderson and Courtland Van Deusen are in the cast.

"Her Doggy." (Biograph. Fri., Sept. 25.)—A lively comedy in which a girl's dog does a number of things which are not expected, but which are appreciated by others.

"The Investment." (Lubin. Fri., Sept. 25.)—Two old people are in love, but their grown-up children offer much opposition to the match. The old man invests his money in an automobile concern, which proves to be a success and the old couple are able to marry.

"You Never Can Tell." (Selig. Fri., Sept. 25.)—This is on the same reel with "Who Got Stung?" Sid Smith, Lillian Leighton and John Lancaster are in the cast. A grocer's clerk wants to become an actor. He is so clumsy he makes a star comedian.

"Who Got Stung." (Selig. Fri., Sept. 25.)—A slapstick comedy on the same reel with "You Never Can Tell." A man plays a joke on his friend by advertising for a lot of scrub women to report at the friend's office. Trouble follows.

UNIVERSAL PROGRAM

"Three of a Kind." (Universal Ike. Tues., Oct. 6.)—Mistaken identity is the theme. The husband, who neglects his wife, is watched by two detectives, who make up to appear like him. When mother-in-law arrives the action begins, which is very laughable. Louise Glaum and Ray Gallagher lead the cast.

"The Baseball Fans of Fanville." (Joker. Wed., Oct. 7.)—William Franey is the star of this Joker company since Max Ashe was transferred to the Sterling company. He plays the lead in this picture and furnishes a

lot of fun, supported by Louise Fazenda, Gale Henry and Sam Kaufman. The boss, who has a date with his wife and mother-in-law to attend a matinee, manages to slip out to the game; they in a rage come after him, but when they see the home team winning, they naturally can't help but cheer.

"Myer's Mistake." (Sterling. Mon., Oct. 5.)—Max Asher as the disappointed suitor will call for many a laugh in this. He feigns death to win the sympathy of the girl, but she has plenty of beaux and flirts with another, while still another disappointed gentleman buries Myer. He doesn't like the buried alive idea and gets out in a hurry.

"Matty, the Universal Boy." (Imp. Thurs., Oct. 8.)—Matty Roubert, the juvenile lead of the series, visits the country in this picture and in a very entertaining manner captures an escaped lunatic.

"The Mayor's Manicure." (Powers. Fri., Oct. 9.)—The cub reporter fails to obtain an interview with the mayor and it rests with a woman to take the job, and she succeeds by posing as a manicure. This is a cleverly produced comedy-drama that will please.

"Out of the Frying Pan." (Nestor. Fri., Oct. 9.)—But into a bed of roses, not into the fire, jumped Eddie, after he had proposed to an old maid, thinking she was his intended instead of her niece. Eddie's attempts to get rid of the persistent spinster are sidesplitting. Ed Lyons, Victoria Forde and Lee Moran play the leads.

"The Man Who Came Back." (Eclair. Sun., Oct. 4.)—In which Joe Ryan again exhibits his great skill in the saddle. He poses as a tenderfoot in the cow country, but soon shows his experience. He has quite a bit of trouble with a jealous Mexican before he finally triumphs over him and wins the ranch owner's daughter, a part played by Mildred Bright.

"Four Days." (Frontier. Sun., Oct. 4.)—Within four days' time two young people have met and the man has proposed after putting the rascally rival to route. This is a fair comedy-drama played by Fred Church, Dolly Larkin and Joe Franz.

"The Pipes of Pan." (Rex. Two reels. Sun., Oct. 4.)—Rather an unusual story played by Pauline Busch, Joseph King, Lon Chaney and Carmen Phillips. The artist, after dreaming of his ideal, seeks her and employs her to pose as his model. He falls in love with this woman, but after a struggle with himself returns to his wife.

"The Old Bell Ringer." (Nestor. Wed., Oct. 7.)—Murdoch MacQuarrie in a character portrayal. The story is quite poor, but Mr. MacQuarrie's fine acting will carry the picture.

"The Senator's Lady." (Powers. Thurs., Oct. 8.)—When his country wife comes to visit him in Washington, the senator is ashamed of her and thinks of deserting her, but then visions come to his mind when he, in his early struggles as a lawyer, was always aided and encouraged by his wife, and how she nursed him when he was sick, and then he asks his wife's forgiveness. Edna Maison, Bert Hadley and Beatrice Van interpret this pretty story.

"The Shack Next Door." (Universal Ike. Tues., Sept. 29.)—The way in which the lover wins the girl of his heart is by stationing a family of Italians in the house next door and forcing the old man to buy it to get rid of them. In this way he makes the required amount of money to marry the girl. Leading the cast of this comedy are Louise Glaum and Ray Gallagher.

"Liferitis." (Crystal. Tues., Oct. 6.)—The conventional story of the professor who invents an elixir of life. He dreams and is chased by a scarecrow, whom he brought to life. He awakes and another chase takes place which grows tiresome toward the end. Vivian Prescott appears in a minor part.

"He Never Said a Word." (Nestor. Fri., Oct. 9.)—The same idea has been pictured before, but it's a good one and worth seeing twice. The visitor to the deaf and dumb asylum mistakes the superintendent's daughter for a deaf mute and vice versa. In the finale each learns that the other can talk. This picture may offend people with this affliction, but otherwise it will be a success.

(Continued on page 64.)

The Productions of

**Famous Players
Film Co.**

*In Association with
Daniel Frohman
Chas. Frohman Henry W. Savage*

**Jesse L. Lasky
Feature Play Co.**

*Associated with
David Belasco
The Liebler Company*

**Bosworth,
Inc.**

*Producers of
Jack London's
Fiction Classics*

Constitute

Paramount Pictures



Paramount Manufacturers Paramount Distributors Paramount Exhibitors
throughout the United States

are cooperating for the universal betterment of the motion picture industry. Their united, persistent efforts mean:

A system of reimbursing the manufacturer that encourages the production of better pictures.

Better methods of distribution, and
Better theatres.

Resulting in:

Greater confidence of the public.

Increased patronage of the best people.

Higher prices of admission, and

Permanent, satisfactory business for all Paramount affiliations.



WRITE YOUR NEAREST EXCHANGE FOR INFORMATION

Watch for next week's announcement of the second three months' releases.

Paramount Pictures Corporation
ONE HUNDRED and TEN WEST FORTIETH STREET
NEW YORK, N. Y.

GET IN LINE AND BOOK

ST. ELMO

SIX PARTS

The Best Money-getting Film of the Year
BROKE ALL BOX-OFFICE RECORDS

A few of the many satisfied theatres that have played ST. ELMO

In New York City

THE STRAND	Broadway	3200 Seats
AUDUBON	Broadway	3500 "
PROCTOR'S	Fifth Avenue	2000 "
RIVERSIDE	Broadway	2600 "
EMPRESS	181st Street	1000 "
GARDEN	The Bronx	1000 "
BEDFORD	Brooklyn	2200 "
CORSE PAYTON'S LEE AVENUE.....	Brooklyn	1800 "
HENDERSON'S	Coney Island	2200 "

and 81 other houses in New York City have booked ST. ELMO.

ST. ELMO

NOW RELEASED in all parts of America. Wire, write or call
on our nearest exchange for an open date.

ST. ELMO

A picture for men, women and children.

MORE SURE-FIRE ATTRACTIONS NOW BOOKING

WILL O' THE WISP.....	4 Reels
FIGHTING THE WORLD	5 Reels
THE SQUARE TRIANGLE	3 Reels

SPECIAL—"LIFE'S SHOP WINDOW"

By Victoria Cross—6 reels.

will be ready for booking October 20th

The Box Office Attraction Company releases 3 features and 3 single reels
weekly.

Also 3 big special productions every month

EXCHANGES

NEW YORK—130 West 46th Street
 CHICAGO—Mallers Building
 CLEVELAND—Columbia Building
 PHILADELPHIA—1333 Vine Street
 DALLAS—1907 Commerce Street

ST. LOUIS—3632 Olive Street
 SAN FRANCISCO—107 Golden Gate Ave.
 PITTSBURGH—121 Fourth Avenue
 SYRACUSE—Eckel Theatre Building
 BOSTON—10 and 12 Piedmont Street

KANSAS CITY—928 Main Street
 DENVER—Ideal Building
 SEATTLE—1214 Third Avenue
 INDIANAPOLIS.
 MINNEAPOLIS—Jewelers Exchange Bldg.

and Eleven Other Cities

THE BOX OFFICE ATTRACTION CO.

WILLIAM FOX, President

EXECUTIVE OFFICES: 130 WEST 46th STREET, NEW YORK

INTERESTING FILM REVIEWS

(Continued from page 61.)

"The Man Who Was Never Kissed." (Victor. Two reels. Fri., Oct. 9.)—Although this picture may appear suggestive in parts, a comical occurrence usually follows after such moments and takes the bad effect away. Florence Lawrence and Matt Moore are the principals. The student of Plato, who has never been kissed, because he believes in only platonic love, finally succumbs to the charms of a young girl. There is some doubt about the two being married, which causes a few scenes to boarder on the risque.

"Cruel, Cruel World." (Joker. Sat., Oct. 10.)—This is an excellent burlesque on the old stage melodrama, interpreted in a side-splitting manner by Louise Fazenda, William Franc, Gale Henry and Sam Kaufman. The snow creates an uproarious effect. The villainous agent must have the rent of the girl, but instead he is vanquished by the hero.

"Disillusioned." (Victor. Mon., Oct. 5.)—A very pretty story is told in this reel interpreted by Jack Kerrigan and Vera Sisson. Attention and admiration for the man is held throughout. The country girl, who has been wronged by a villainous man, is ostracized by all except an old lover, who still remains her friend and later marries her.

"In the Hollow of an Oak." (Frontier. Sun., Oct. 18.)—In which Joe Franz, as the villain, is again frustrated in an attempt to rob a girl. Not much excitement in this until the end. Lots of riding. Dolly Larkin and Fred Church are the lovers.

"Hypnotic Power." (Sterling. Thurs., Oct. 8.)—Ford Sterling himself in an excellent fun maker. Seeing that his rival is favored, Ford exerts his hypnotic powers over him with disastrous results. But he is foiled in the end and the other man marries the girl.

MUTUAL PROGRAM

"He Loved the Ladies." (Keystone, Mon., Sept. 21.)—Amusing comedy of the irrepressible flirt, with Charles Murray portraying the agreeable part in lifelike fashion. Of course the flirt is a husband and well watched by his wife when he is at home, but this time he pretends that he is going off to another city, and surreptitiously indulges in a little high life, and his wife does likewise. Everybody knows what happens then. They meet in the cafe.

"Killing Horace." (Keystone, Thurs., Oct. 1.)—Here we have the amusing adventures of the pestilent flirt who finally comes to grief through his very persistence, a quality that in a better line we have been accustomed to hear will bring riches and affluence. Charles Murray is the funmaker.

"The Runaway Freight." (Reliance. Two reels. Sat., Sept. 26.)—A real thriller appears in the latter part of this picture when two freight cars leave the rails and plunge into a river. Several realistic scraps occur between the reformed crook and his old associates. How he wins the station master's daughter makes a fine story. Eugene Pallett and Francelia Billington play the leads.

"The Final Test." (Princess. Sept. 25.)—A girl helps a philanthropic young doctor in his work, but becomes engaged to another man. On her wedding day she sees him strike down one of the poor patients of her medical friend. She realizes her mistake and marries the better man. Boyd Marshall and Renc Farrington are the principals.

"Lover's Luck." (Keystone. Sat., Sept. 19.)—Slightly diverting farce of the fat office boy, his lean rival for the hand of the village belle, and the country constable that gets caught in the widow's kitchen. The latter to keep from compromising himself hides in the closet, and the fat boy and the girl hide there, too, and make the constable marry them on the spot. Roscoe Arbuckle is the fat boy.

"The Whiskey Runners." (Domino. Two reels. Thurs., Oct. 8.)—Pathetic and appealing drama. The whiskey runners are man and wife and they sell the firewater to the Indians against the law. The man is beaten and with a mortal wound goes home to die. But he sends his wife to the sheriff so that she may get half of the reward that is offered for his arrest, and when the wife returns the man is dead.

"The Sheriff of Muscatine." (Kay Bee. Two reels. Fri., Oct. 9.)—A startling surprise is introduced at the end of this picture, that if it only seemed more probable would be splendid. But it is too evidently a makeshift. A desperado is captured, his mother arrives at the same time, and he begs to be allowed at liberty for her sake. The mother turns out to be his girl and they rob everything and everybody and get away.

"The Trail of the Love Lorn." (Than-houser. Two reels. Tues., Sept. 29.)—This is a good entertainer, but contains nothing exceptionally extraordinary. Two get-rich-quickers are finally foiled in their last money-getting scheme, which consists of placing the picture of a girl in the paper, and advertising for a husband, then swindling the applicants.

"The Scarecrow." (Royal. Sat., Sept. 26.)—Not much unity of plot to this comedy. In order to get away from his ugly wife, whom he married while intoxicated, the young man poses as a scarecrow, but he is found out, and forced to return home with her. Fair humor. The lead is played by Louis Simon.

"The Harvest of Regrets." (Thanhouser. Sun., Sept. 27.)—Plain but good. The young man who is engaged to a country girl is denounced by a former companion and adventurer. When he saves the girl from an unwelcome suitor he redeems himself in her eyes. Harry Benham is the lead.

"Cousin Billy." (Royal. Sat., Oct. 3.)—Billy is from the country and is not warmly welcomed by his cousin's husband. His antics in the rich man's house are not exactly funny, but will pass the picture off as a comedy. Louis Simon plays Billy.

"Fatty's Debut." (Keystone. Sat., Sept. 26.)—Roscoe Arbuckle is the funmaker in this laughable farce. He keeps his wife and mother-in-law waiting to go to the theatre and when he does arrive, he is tipsy. A forced plunge into cold water sobers him up a bit, and they start off to the show. But Fatty gets in the wrong door and breaks up the performance when he makes his initial appearance on the stage.

"A Modern Rip Van Winkle." (American. Two reels. Tues., Sept. 28.)—A life-time man is released for good behavior at the end of twenty-five years. He returns to the frontier town in which he committed his crime to find it a great modern city. The rush and roar bewilder him. Two crooks try to get his aid but fail. He is so lonely that he goes to the prison and asks to be taken back. A home in the country is found for him.

"Our Mutual Girl," Chapter 37. (Reliance. Tues., Sept. 28.)—Another of the installments written by Carolyn Wells. Margaret's plans for the care of her little protegee Baby Lily are developed. Her aunt being away, she is offered the use of her friend's home during her absence, and moves there with her Aunt Abbie from Maryland as a chaperone.

"The Last Shot." (Reliance. Wed., Sept. 23.)—One of Arthur Macklay's western dramas, which shows the remarkable dramatic ability of a little child. The innocent man pursued by the sheriff, uses his last shot to save a little child from a rattle snake. Later his innocence is proved.

"Bill Manages a Prize Fight." (Komic. Sun., Sept. 27.)—Bill sees how a prize fight promoter makes easy money, and trains a fighter of his own. By a trick the real pugilist is knocked out and Bill becomes his manager. Fay Tincher and "Tammany Bill" Young head the cast.

"The Legend of Black Rock." (Beauty. Wed., Sept. 29.)—A Spanish girl is the sole survivor of a wreck. She falls in love with her rescuer, but he marries his boyhood sweetheart. She disappears, but is supposed to haunt the rocks on stormy nights. The story is told to two small children by their grandmother. Margarita Fischer is featured.

NEWS WEEKLIES

"Mutual Weekly, No. 91."—The war views maintain the same interest characterizing former topical pictures of this nature. So much has been heard of the dreaded Turcos that everybody will be curious to see what they look like. This number of the weekly pre-

sents an excellent picture of these savage warriors fighting in the cause of France. Among other views are: Society women and royalty making supplies for the Red Cross; the famous Grenadier Guards leaving London for the front, and English artillery leaving for the seat of hostilities.

"Hearst-Selig News Pictorial No. 57." (Selig. Mon., Sept. 14.)—The Red Cross, the vessel fitted out to help the distress on the battle fields of Europe, occupies the center of interest. It is photographed setting out from New York harbor, and the nurses in simple uniforms are seen on board, happy in the thought of the good that they will be able to do. Of course no pictures can be made on the actual scene of war, because cameras are forbidden, but the recruiting of troops in England is of interest.

"Animated Weekly, No. 133."—The pictures this week show a pleasing variety of subjects, and, of course, include a number of war views. Among the latter are: Canadian troops starting for the war zone from the western part of the Dominion; the honoring of the French colors as a regiment departs from Paris; English artillery passing through London; crowds gathered before bulletin boards in Paris; first regiment of Boy Scouts in England that offered its services to their country.

INCORPORATIONS

ALCO FILM CORPORATION; manufacture and deal in theatre appliances for making moving pictures; \$1,500,000; Manhattan; Walter H. Seeley, Suffern, N. Y.; Alexander Lichtman, New York; Wm. Sievers, St. Louis, Mo., and eight others.

THE WARRICK AMUSEMENT CORPORATION; theatrical and motion pictures; \$10,000; Manhattan; Henry G. Wiley, E. K. Harris, R. A. Kohn and one other, of New York.

AMALGAMATED PHOTO FEATURE BOOKING CORPORATION; general theatrical, motion picture and feature business; \$1,000; Manhattan; Edna Egan, Claire Goldberg and Martin Hoffman, of New York.

ASCHER'S CLASSIC COMPANY, INC.; vaudeville and motion pictures; \$4,500; Manhattan; Sidney Ascher, Jos. A. Jacobs, Sidney Rice and one other, of New York.

ASCHER'S COLONIAL COMPANY, INC.; vaudeville and motion pictures; \$4,500; Manhattan; Sidney Ascher, Jos. A. Jacobs, Sidney Rice and one other, of New York.

MARLBOROUGH AMUSEMENT COMPANY; motion pictures and theatrical; \$10,000; Brooklyn; Morris and Annie J. Hausen, Rose Miness and one other, of Brooklyn.

STAGE PRODUCING COMPANY, INC.; theatrical, musical, motion picture business; \$125,000; Manhattan; Milton W. Williams, Ethel M. Winfield and Arthur Linn, of New York.

MOTION PICTURE SPECIALTY COMPANY; motion pictures; \$10,000; Manhattan; Henry R. Johnson, Samuel Mathewson and H. E. Ringholm, of New York.

MADISON OPERATING CORPORATION; general theatrical and motion pictures; \$500; Manhattan; John J. Maloney, Phillip F. Nash and Maurice Goodman, of New York.

CHAMPLAIN FILMS, INC.; Manhattan; motion pictures, etc.; capital \$25,000. Incorporators: L. J. Hartmann, T. B. Hoy, New York City; E. C. Hobcroft, Bronx.

At Nashville, Tenn.: THE TENNESSEE INDUSTRIAL FILM COMPANY, of Knoxville, with a capital stock of \$12,000, asked a charter. Incorporators are R. C. Wright, E. A. Seahorn, Charles I. Barber, H. D. Dobson and Henry Hudson.

At Frankfort, Ky.: THE S. & P. FILM SUPPLY COMPANY; \$1,500; Louisville. C. A. Pressy, F. M. Sheldon and R. H. Lucas.

At Springfield, Ill.: THE SCHILLER FILM COMPANY OF CHICAGO. \$20,000; general motion picture business. Fred Plotke, Morris J. Drezner and Charles Lorneman.

RIGHT OFF THE REEL

Evelyn Selbie, the clever actress of the Essanay western company, is never happy unless dressed in a corduroy outing suit, and she cares little for social affairs. She spends her week ends at a small bungalow, which she takes great pride in keeping in good shape.

True Boardman, besides being one of the leading men for the western Essanay company, is quite a chicken financier. When not busy taking a scene True may be seen trying to round up his stray chickens.

Arizona Operators Object to Owner in Booth

Phoenix Local Declares That Robert Pratt, Said to Have Third Interest in the Lion, Must Join Union

Special to THE MOTION PICTURE NEWS

Phoenix, Ariz., Sept. 28.

THE first concerted action by the operators' local is about to be directed toward The Lion Theatre here. The men at the crank profess to believe that Walter B. Leecraft, of the Lion, is violating their regulation covering men in the operating booth. The details are as follows:

The Lion is owned by three men, one of whom is Robert Pratt. The latter, during the dull season incidental to the hot months, has been working a shift in the lamp room. The operators' local, recently a year old, contends that Pratt, whom the other men in the combination say is full one-third owner, cannot work without joining the union.

Pratt, who is a member of the musicians' local, and who plays in the orchestra in the winter season, contends that he has a right to run the machine on the ownership basis, and this he has been doing for some time.

Along this line the union has called out its man who was working opposite Pratt, and the matter has been referred to the trade council. It has been said that the local is to demand that the same condition be respected in one or more of the other houses where a proprietor is working a shift at the projection machine.

What will become of the controversy is yet a matter of conjecture. Phoenix, while it has many trades unionists, is not what might be called a strictly union city. The state statute books contain a law permitting so-called "picketing," but a recent attempt of the Cooks' and Waiters' Union to boycott an open shop restaurant met with much opposition on the part of the men of the cafe.

Opposition, however, came from another quarter before very long.

The public and both papers took the side of the defendants. The boycott was called off by order of the police and the affair shows that the city is not too strong for this method of forcing a demand. The operators say that they will not deviate from their regulation, and Leecraft is as firm in his determination to stick by what he thinks is his right in the matter. J. C. RICKARDS.

Expert Repairing All Makes
**Moving Picture Projectors
 and Cameras**
Ernemann Photo Kino Works
 163 W. 48th St., New York

Kinematograph Weekly

\$5.15 a Year

The Leading Motion Picture
 Publication of Great Britain and
 Colonies

[Sample Copies 10 cents

[For Advertising Rates Write

Associated Moving Picture Press
 250A Kingston Ave., Brooklyn, N. Y.

SAFETY FIRST

Make the return on your investment safe and sure by good projection. The popularity of your house depends more on steady, clear and flickerless pictures, than by the class of films you show.

We are the Distributors for the Motiograph, Powers, Simplex and Edison Machines and Genuine Repair Parts and Supplies.

Can Rebuild your old machine just as good as new. Work Guaranteed. We sell for cash or on easy payments. Send for catalog today.

AMUSEMENT SUPPLY COMPANY 160 No. Fifth Ave.
 CHICAGO



OFFERED FREE BY THE GOTHAM FILM CO.

Has brought many an Exhibitor more patrons than his theatre could handle

WITHOUT ANY ADDITIONAL COST TO THE EXHIBITOR

we guarantee with our exclusive plan

to swell your box office receipts—This sounds too good to be true

INVESTIGATE THIS! IT IS FOR YOUR OWN BENEFIT

A postal or the accompanying coupon will bring you full particulars

GOTHAM FILM CO., Times Bldg., New York

Gotham
 Film Co.,
 Times Bldg.,
 New York City

At your expense send me all information concerning "One Good Idea" to increase my box office receipts.

AT LIBERTY—BERT ANGELES

Director of Comedies
 and Dramatic Features

Formerly director with Vitagraph, Imp, Pilot and
 Historical Film Company

ADDRESS AT ONCE

SCREEN CLUB, 165 West 47th Street, New York

A**A**

ALLIANCE PROGRAM

NOTICE TO THE TRADE

The Productions of the Favorite Players Film Co., Inc., will be released exclusively through the Alliance Films Corporation.

Our first subject in the Alliance Program will be

The Key to Yesterday

A strong, stirring, four-part feature of exceptional merit, picturized from the book by Charles Nevill Buck (Scenario by Robert A. Dillon)

With Carlyle Blackwell

in the leading role, supported by J. Francis Dillon, Miss Edna Mayo, John J. Sheehan, John Prescott, Gypsy Abbott

and 100 others

RELEASED OCTOBER 12

FAVORITE PLAYERS FILM COMPANY, Inc.
M. H. BLACKWELL, TREAS.

110 W. 40th St. Suite 1002 New York City

A**A**

A**A**

ALLIANCE PROGRAM

Important Announcement

The Excelsior Feature Film Company, Inc., will release all its subjects through the Alliance Films Corporation, beginning with

The Path Forbidden

Dramatized from the book by John B. Hymer, in five parts. An intense human interest production, wonderfully acted, with

Octavia Handworth

The peerless star of the silent drama in the leading role, supported by Gordon De Maine, William A. William, John B. Hymer, and a large cast.

Marvelous Scenes

are presented, in exquisite photography, which will cause audiences to sit spell-bound in wonder and amazement. Through trick work and double exposure, Miss Handworth, playing the dual role of the twin sisters, is actually seen shaking hands with herself, and handing to, and taking from herself various articles, both figures being photographed close to the camera. This work has been pronounced by experts the most intricate ever attempted, and is the first time in the history of motion pictures that the feat has been accomplished.

RELEASED OCTOBER 19

EXCELSIOR FEATURE FILM COMPANY, Inc.
110 W. 40th St. Suite 1002 New York City

Harry Handworth, Pres.

Arthur Rosenbach, Sales Mgr.

Wm. H. Wright, Treas.

A**A**

A

ALLIANCE

A combination of the World's Greatest Feature Photographing plan which insures to the better Theatres to secure **Big Features**

The exhibitor is the sole arbiter of the manufacturer's success, because his profit is derived solely from the popularity of the film. Each unit is independent of the other, obviating a forced program, and absolutely eliminating all element of chance in the quality of the releases.

Each manufacturer stands by himself, receiving a percentage of the bookings. The better picture he makes the more benefit he will derive. This is a tremendous incentive for rivalry in the race for quality.

The Alliance Films Corporation is not interested in the exchanges, nor the manufacturing companies. The manufacturing companies are not interested in the exchanges.

POWERFUL SUBJECTS

Date	Title of Film	Producer	Star
Oct. 12	THE KEY TO YESTERDAY	Favorite Players	Carlyle Blackwell
Oct. 19	THE PATH FORBIDDEN	Excelsior	Octavia Handworth
Oct. 26	AT THE OLD CROSS ROADS	Select	Estha Williams
Nov. 2	(To be announced)		
Nov. 9	(To be announced)		

PRODUCED BY MASTERS IN

FAVORITE PLAYERS FILM CO., Inc.
EXCELSIOR FEATURE FILM CO., Inc.

Next week's announcement giving a list of exchanges prizes. Watch

ALLIANCE FILMS

11th Floor

Leavitt Building

A



PROGRAM

Play Producers in a direct-to-exhibitor co-operative book-
 an absolutely dependable source from which
 for 52 weeks of the year.

Every subject must be submitted to the exchanges before it is placed in the ALLIANCE PROGRAM, and an unbiased and uninfluenced committee judicially passes upon the drawing power of the film, the photography and acting.

The confidence of the manufacturer in his ability to produce the greatest films in the world, and his determination to do so, is apparent; otherwise these producers would not be willing to enter into such an arrangement. This statement is not made for mere publicity purposes, but is an actual, bona fide fact. There are many agreeable surprises in store for the exhibitor who will watch for 'ALLIANCE ANNOUNCEMENTS, but it must not be forgotten that every producer affiliated with the ALLIANCE FILMS CORPORATION must agree to the conditions hereinabove stated.

FOR EARLY RELEASE

Date	Title of Film	Producer	Star
Nov. 16	THE MAN WHO COULD NOT LOSE	Favorite Players	Carlyle Blackwell
Nov. 23	THE SHADOW	Excelsior	Octavia Handworth
Nov. 30	(To be announced)		
Dec. 7	AN UNFINISHED STORY	Favorite Players	Carlyle Blackwell
Dec. 14	WHEN FATE LEADS TRUMP	Excelsior	Octavia Handworth

THE ART OF FILM MAKING

SELECT PHOTOPLAY PRODUCING CO., Inc.
 And other manufacturers to be announced.

handling the Alliance Program will disclose many sur-
 for it.

CORPORATION

126 West 46th Street

New York City



A

A

ALLIANCE PROGRAM

SPECIAL NOTICE:

The Select Photoplay Producing Co., Inc., will release all its feature films through the Alliance Films Corporation. The first subject is:

“At the Old Cross Roads”

Released October 26, in five reels, featuring

Miss Estha Williams

in her original role of Parepa, supported by Mrs. Stuart Robson, Arthur Morrison, Miss Rae Ford, Master Martin, and a large cast.

This play was sent out for fourteen consecutive seasons by Arthur C. Aiston, covering every state in the Union, and has repeatedly broken box office receipts in high class legitimate theatres. It is probably the best known play in America, and its tremendous heart appeal is thoroughly known.

MANY BIG SCENES

The Burning of the Bridge
The Uprising of the Blacks and the Ensuing Battle
The Battle at the Old Cross Roads
The Sensational Court Room Scene

Scenario by Frank L. Dear. Produced by Mr. Dear

SELECT FEATURE PHOTOPLAY CO., Inc.

S. G. LINDEMAN, Treasurer

71 W. 23rd St.

New York City

A

A

What Do You Need?

LISTING IN THE BUYERS' GUIDE, FOR NAME AND ADDRESS, INCLUDING ONE YEAR'S SUBSCRIPTION TO THE MOTION PICTURE NEWS—\$8.00 A YEAR, CASH IN ADVANCE. FREE TO ADVERTISERS USING \$100.00 OR MORE WORTH OF DISPLAY SPACE DURING THE YEAR. ADDRESS ADVERTISING DEPARTMENT

ADVERTISING NOVELTIES

Philip Hano, 806-810 Greenwich St., New York.

ANNOUNCEMENT SLIDES

Niagara Slide Co., Lockport, N. Y.

ASEBESTOS BOOTHS

Sharlow Bros., 442 W. 42nd St., New York.

CLEANING AND RENOVATING FILM

Film Redeveloping Co. of America, 145 W. 45th St., N. Y.
Multicolor Film Improving Co., Inc., 15 E. 26th St., N. Y.

COSTUMERS

Miller-Costumier, 236 South 11th St., Philadelphia, Pa.

DEVELOPING TANKS

A. J. Corcoran, Inc., 9 1/2 John St., New York.

ELECTRIC LIGHTING SETS

The Chas. A. Strelinger Co., Box P-2, Detroit, Mich.

FILMS

(Manufacturers, Dealers and Renters)
American Film Mfg. Co., Chicago, Ill.
Thomas A. Edison, Inc., 275 Lakeside Ave., Orange, N. J.
Essanay Film Mfg. Co., First National Bank Bldg., Chicago, Ill.
General Film Co., 200 Fifth Ave., New York.
George Kleine, 166 N. State St., Chicago, Ill.
Luhin Mfg. Co., Philadelphia, Pa.
G. Melies, 204 E. 38th St., New York.
Mutual Film Corp., 71 W. 23rd St., New York.
New York Motion Picture Corp., Longacre Bldg., New York.
Pathé Freres, 1 Congress St., Jersey City, N. J.
Renfax Film Co., Inc., 110 W. 40th St., N. Y.
Selig Polyscope Co., Chicago, Ill.
Thanhouser Film Corp., New Rochelle, N. Y.
Universal Film Mfg. Co., 1600 Broadway, N. Y.

FILM ACCESSORIES

Berlin Aniline Works, 213 Water St., N. Y.

FILM TITLES, PRINTING, DEVELOPING, ETC.

Commercial Motion Pictures Co., Inc., 220 W. 42nd St., New York.
Centaur Film Co., 670-682 Ave. E, Bayonne, N. J.
Evans Film Mfg. Co., 412-22 W. 216th St., at Broadway, New York.
Gunby Bros., Inc., 145 W. 45th St., New York.
Industrial Moving Picture Co., 223-233 W. Erie St., Chicago.
Standard Motion Picture Co., 5 S. Wabash Ave., Chicago.
Standard Filmprint Corp., 120 School St., Yonkers, N. Y.

FILM REELS

Lang Mfg. Works, Olean, N. Y.
Taylor-Shantz Company, 224 Mill St., Rochester, N. Y.

FURNITURE AND FURNISHING ON RENTAL

William Birns, 103-105 West 37th St., N. Y.

FEATURE FILMS

Alco Film Corp., 218 W. 42d St., New York.
Alliance Films Corp., 126 W. 46th St., New York.
Alhauquerque Film Mfg. Co., Inc., 406 Court St., Los Angeles, Calif.
All Star Feature Corp., 220 W. 42nd St., N. Y.
Ambrosio American Co., 15 E. 26th St., N. Y.
Bosworth, Inc., 640 N. Olive St., Los Angeles, Cal.
Box Office Attraction Film Rental Co., 130 W. 46th St., New York.
A. Blinkhorn, 110 W. 40th St., New York.
California Motion Picture Corp., San Francisco, Cal.

Cosmofotofilm Co., 110 W. 40th St., New York.
Cosmos Feature Film Corp., 126-130 W. 46th St., N. Y. City.

Direct-From-Broadway Features Co., 46 W. 24th St., New York.

Eclair Film Co., 126 W. 46th St., New York.

Eclectic Film Co., 110 W. 40th St., New York.

Excelstor Feature Film Corp., Inc., 110 W. 40th St., N. Y.

G. W. Feature Film Corp., 145 W. 45th St., N. Y.

Features Ideal, 126 W. 46th St., New York.

Famous Players Film Co., 213-229 W. 26th St., New York.

Films Lloyds, Inc., 220 W. 42nd St., N. Y.

General Film Co., 200 Fifth Ave., New York.

General Feature Film Co., 313 Mallers Bldg., Chicago, Ill.

Gaumont Co., 110 W. 40th St., New York.

Greene's Feature Photo Plays, Inc., 110 W. 40th St., New York.

W. W. Hodgkinson, 110 W. 40th St., New York.

Imperial Motion Picture Co. of N. Y., Inc., 1476 Broadway, N. Y.

Inter-Continent Film Co., 110 W. 40th St., New York.

George Kleine Attractions, 166 N. State St., Chicago, Ill.

New York Office: 1476 Broadway.

Jesse L. Lasky Feature Play Co., Longacre Theatre, New York.

Life Photo Film Corp., 220 W. 42nd St., N. Y.

Mecca Feature Film Co., Inc., 126 W. 46th St., New York.

Mohawk Film Co., Times Bldg., New York.

Oz Film Mfg. Co., Santa Monica Blvd., Los Angeles, Cal.

Paramount Pictures Corp., 110 W. 40th St., New York.

Phoenix Feature Film Corp., 164 Federal St., Boston, Mass.

Photo Play Production Co., 220 W. 42nd St., New York.

Picture Playhouse Film Co., 110 W. 40th St., New York.

Playgoers Film Co., Lyric Theatre, New York.

Popular Plays and Players Co., 1600 Broadway, New York.

Progress Film Co., 110 W. 40th St., New York.

Progressive Motion Picture Corp., Times Bldg., New York.

Ramo Films, Inc., Columbia Theatre Bldg., New York.

Rolands Feature Film Co., 145 W. 45th St., New York.

A. H. Sawyer, Inc., 1600 Broadway, New York.

Select Photo Play Producing Co., Inc., 71 W. 23rd St., New York.

Sterling Camera & Film Co., 145 W. 45th St., New York.

Solax Co., Fort Lee, N. J.

The Masterpiece Film Mfg. Co., 1111 Van Nays Bldg., Los Angeles, Cal.

The Photoplay Productions Releasing Co., 37 S. Wabash Ave., Chicago, Ill.

Union Features, 126 W. 46th St., New York.

Universal Film Mfg. Co., 1600 Broadway, N. Y.

University Films, Inc., 110 W. 40th St., N. Y.

Edw. H. Wagner, Agt., Dania Biofilm Co., 38 Park Place, N. Y.

World Film Corporation, 130 W. 46th St., New York.

Warner's Features, Inc., 130 W. 46th St., N. Y.

LANTERN SLIDE MATS AND REEL BANDS

Lantern Slide Mat Co., 149 W. 35th St., N. Y.

LABELS

Every Ready Roll Label Co., 203-7 W. 40th St., New York City.

LIGHTING PLANTS

Cushman Motor Works, Lincoln, Neb.

LOBBY PHOTOS

The Wyanoak Puh. Co., 136 W. 52nd St., N. Y.

MOTION PICTURE MACHINES AND SUPPLIES

Amusement Supply Co., 160 E. North Fifth Ave., Chicago, Ill.

Calehuff Supply Co., 1301 Race St., Philadelphia, Pa.

Enterprise Optical Co., 568 W. Randolph St., Chicago, Ill.

Lears Theatre Supply Co., Sam Lears, Prop., 509 Chestnut St., St. Louis, Mo.

Oliver Moving Picture Supply Co., 647 Euclid Ave., Cleveland, O.

Picture Theatre Equipment Co., 21 E. 14th St., New York.

Precision Machine Co., 317 E. 34th St., N. Y.

Nicholas Power Co., 90 Gold St., New York.

The Phantoscope Mfg. Co., Washington, D. C.

Sweeley's Photo Supply House, 514-516 Erie Ave., Renova, Pa.

Williams, Brown & Earle, Inc., 916-918 Chestnut St., Philadelphia, Pa.

MOTION PICTURE APPARATUS

Burke & James, Inc., 240-258 E. Ontario St., Chicago, Ill.

MUSICAL INSTRUMENTS

Rudolph Wurlitzer Co., Cincinnati, O.
American Photoplayer Co., 62 W. 45th St., New York City.

POSTER AND PICTURE FRAMES

Menger & Ring, 442 W. 42nd St., New York.

RAW FILM

Eastman Kodak Co., Rochester, N. Y.

Celluloses Planchon, Inc., 75 Fifth Ave., New York.

David Horsley, 1600 Broadway, N. Y.

Raw Film Supply Co., 15 E. 26th St., N. Y.

OPERA CHAIRS

The Hardesty Mfg. Co., Canal Dover, Ohio.

Steel Furniture Co., Grand Rapids, Mich.

PIPE ORGANS

Henry Pilcher's Sons, 914-920 Mason Ave., Louisville, Ky.

M. P. Moller, Hagerstown, Md.

PROJECTION LENSES

Bausch & Lomb Optical Co., 569 St. Paul St., Rochester, N. Y.

POSTERS

The Morgan Lithograph Co., Cleveland, Ohio.

REWINDERS AND GENERAL SUPPLIES

L. C. Smith Co., Schenectady, N. Y.

SCREENS

Atsco, Inc., 218 West 42nd St., New York.

Day & Night Screens, Inc., 110 W. 40th St., New York.

Mirror Screen Co., Inc., Shelbyville, Ind.

STEEL FILM EQUIPMENT FOR EXCHANGES AND MFRS.

Columbia Metal Box Co., 226-228 E. 144th St., New York.

TICKETS—ROLL AND COUPON

Rees Ticket Co., 400 S. 10th St., Omaha, Neb.

THEATRE LOBBY FRAMES AND FIXTURES

Newman Mfg. Co., 715 Sycamore St., Cincinnati, O.

UNIFORMS

Fechheimer Bros., Union-made Uniforms, Cincinnati, O.

VENTILATION, COOLING AND HEATING

Typhoon Fan Co., 1544 Broadway, N. Y.

Record of Current and Coming Releases

GENERAL FILM PROGRAM

RELEASES OF THE WEEK

Monday, September 28, 1914.

BIOGRAPH—A First Class Cook, C., 583.....	16067
The White Hand Society, C.....	
EDISON—Love by the Pound, C., 1000.....	16073
ESSANAY—Sweedie Clean-up, C., 1000.....	16075
KALEM—The Viper, D., 2000.....	16068
LUBIN—An Affair of Honor, 3rd of Beloved Ad- venturer, D., 2000.....	16076
SELIG—The Going of the White Swan, D., 2000...	16070
SELIG—Hearst-Selig News Pictorial No. 61, N...	16074
VITAGRAPH—When the Gods Forgive, D., 1000..	16072

Tuesday, September 29, 1914.

BIOGRAPH—The Derelicts, D., 1032.....	16087
EDISON—The Mystery of the Glass Tubes, D., 1000.....	16077
ESSANAY—White Lies, D., 1000.....	16078
KALEM—Grouch, the Engineer, D., 1000.....	16068
KLEINE—A Shot from Ambush, D., 2000.....	16079
LUBIN—Jinks and the Barber, C., 400.....	16084
Jealous James, C., 600.....	
MELIES—A Circus Romance, C., 900.....	16085
SELIG—The Real Thing in Cowboys, C., 1000.....	16081
VITAGRAPH—Regan's Daughter, D., 2000.....	16082

Wednesday, September 30, 1914.

EDISON—Buster Brown Gets the Worst of It, C., 550, and In a Prohibition Town, C., 500.....	16089
ESSANAY—The Fable of "The Adult Girl Who Got Busy," C., 1000.....	16092
KALEM—The Ex-Convict, D., 1600.....	16090
Food for the Dogs of War, E., 400.....	
LUBIN—His Brother Bill, D., 2000.....	16095
SELIG—The Loyalty of Jumbo, D., 1000.....	16094
VITAGRAPH—The Heart of Sonny Jim, C., 1000..	16093

Thursday, October 1, 1914.

BIOGRAPH—The Spirit of Jealousy, D., 1000....	16097
ESSANAY—Slippery Slim Gets Cured, C., 1000....	16098
LUBIN—His First Case, D., 2000.....	16099
MELIES—Blind Marriage, C., 1000.....	16101
SELIG—Hearst-Selig News Pictorial No. 62, N....	16103
VITAGRAPH—The Love of Pierre Larosse, D., 1000.....	16102

Friday, October 2, 1914.

BIOGRAPH—The Peasant's Lie, D., 998.....	16112
EDISON—The Poisoned Bit, D., 2000.....	16104
ESSANAY—Golf Champion "Chick" Evans Links with Sweedie, C., 2000.....	16106
KALEM—The Slavery of Foxicus, C., 1000.....	16108
LUBIN—The Greater Love, D., 1000.....	16111
SELIG—An Embarrassing Predicament, C., 1000...	16109
VITAGRAPH—Eats, C., 1000.....	16110

Saturday, October 3, 1914.

BIOGRAPH—The New Road's Mascot, D., 1000..	16119
EDISON—A Transplanted Prairie Flower, D.....	16113
ESSANAY—Broncho Billy Trapped, D., 1000....	16114
KALEM—The Legend of the Amulet, D., 1000...	16118
LUBIN—On Circus Day, C., 1000.....	16115
SELIG—Four Minutes Late, D., 1000.....	16120
VITAGRAPH—The Royal Wild West, C., 2000....	16116

RELEASES OF NEXT WEEK

Monday, October 5, 1914.

BIOGRAPH—The Borrowed Book, D., 1000.....	16121
EDISON—Father's Beard, C., 1000.....	16127
ESSANAY—The Fickleness of Sweedie, C., 1000..	16129
KALEM—The Dancer, D., 2000.....	16122
LUBIN—An American Heiress, The Beloved Ad- venturer, Series No. 4, D., 1000.....	16130
SELIG—The Moving Picture Cowboy, C., 2000...	16124
SELIG—Hearst-Selig News Pictorial No. 63, N., 1000.....	16128
VITAGRAPH—Fisherman Kate, C., 1000.....	16126

Tuesday, October 6, 1914.

BIOGRAPH—Gwendolin, D., 1945.....	16141
COLUMBUS—What Would You Do? C., 1000.....	16139
EDISON—Greater Love Hath No Man, D., 1000..	16131
ESSANAY—The Verdict, D., 1000.....	16132
KALEM—For the Love of Mike, C., 800.....	16140
Hesanut Hunts Wild Game, C., 200.....	
KLEINE—The Wrecked Special, D., 2000.....	16133
LUBIN—Wife's Athletic Mamma, C., 400.....	16138
A Hunting Absurdity, C., 600.....	
SELIG—The Way of the Redman, D., 1000.....	16135
VITAGRAPH—His Unknown Girl, D., 2000.....	16136

Wednesday, October 7, 1914.

EDISON—Seth's Sweetheart, C., 1000.....	16143
ESSANAY—The Fable of "The Family That Did Too Much for Nellie," C., 1000.....	16146
KALEM—The Lost Mail Sack, D., 2000.....	16144
LUBIN—The Girl at the Lock, D., 2000.....	16149
SELIG—The Reparation, D., 1000.....	16148
VITAGRAPH—Kill or Cure, C., 1000.....	16147

Thursday, October 8, 1914.

BIOGRAPH—Their Little Drudge, D., 1000.....	16151
COLUMBUS—The New Apprentice, C., 750.....	16155
Kissing Germ, C., 250.....	
ESSANAY—When Slippery Slim Met the Cham- pion, C., 1000.....	16152
LUBIN—In Old Virginia, D., 2000.....	16153
SELIG—Hearst-Selig News Pictorial No. 64, N....	16157
VITAGRAPH—The Loan Shark King, D., 1000..	16156

Friday, October 9, 1914.

BIOGRAPH—They Were College Boys, C., 496... The Man Hunters, C., 503.....	16167
EDISON—The Long Way, D., 3000.....	16158
ESSANAY—The Real Agatha, D., 2000.....	16161
KALEM—The Tattered Duke, C., 1000.....	16163
LUBIN—The Green Eyed Monster, D., 1000.....	16166
SELIG—Jimmie, the Porter, C., 500.....	16164
Doc Yak's Bottle, C., 500.....	
VITAGRAPH—Josie's Legacy, C., 1000.....	16165

Saturday, October 10, 1914.

BIOGRAPH—His Mother's Home, D., 999.....	16174
EDISON—A Fragment of Ash, D., 1000.....	16168
ESSANAY—Broncho Billy and the Greaser, D....	16169
KALEM—Fate's Midnight Hour, D., 1000.....	16173
LUBIN—When the Ham Turned, C., 1000.....	16170
SELIG—Her Victory Eternal, D., 1000.....	16175
VITAGRAPH—The Rose and the Thorn, D., 2000..	16171

In and Out of Los Angeles Studios

(Continued from page 39.)

Wallace Reid, Billie West and Al Fillson.

Sheriff Saves Town from Flood

Sheriff Arthur Mackley brought out his star and polished it up last week, and then produced "Out of the Deputy's Hands" for Reliance-Mutual release. In this the sheriff saved the inhabitants of a Western town from death by flood when he brought the inmates from prison and worked side by side with them. The scenario is from a story appearing in *The Cavalier Magazine*.

That a motion picture ship effected the rescue of the wrecked Stefansson Arctic exploration ship party is told in letters received here by relatives of Fred L. Granville, cameraman, with the Sunset Motion Picture Company expedition, whose home is in this city.

Members of the Sunset party learned the explorers' ship had been wrecked, and went in search of it. When the eleven survivors were found on Wrangle Island, among the first things that happened to them was having their pictures made. The rescued party was later transferred to the revenue cutter Bear.

The Sunset Company has offices at San Francisco, and, according to letters received, the part has made more than 25,000 feet of negative in the north zone, all of which is now on the way to Los Angeles, where it will be developed and printed.

From Bell Hop to Photo Expert

William Foster, new superintendent of photography at the West Coast Universal studio, is a real for sure self-made man. Because his parents could not afford to send him to school, he ran away from home when twelve years of age, became a bell hop and attended night school.

Then he joined a circus, where he saw his first motion picture machine. He learned to operate it, and then became an expert at installing machines.

Four years ago he had never made a picture of any kind, but now the officers of the largest motion picture company think he is the most competent man to have in charge of the western division

of their motion picture organization.

At a recent meeting of the directors of the Photoplayers' Club, Wallace Reid, a member of the Majestic-Mutual and Reliance-Mutual studio stock companies, was selected to fill the vacancy in the office of secretary and treasurer, made by the resignation of Henry Otto.

Mr. Otto has been at Santa Barbara for the past several months, and absence from here makes it impossible, he believes, to efficiently perform the duties of the office.

May Make Negatives for Lubin

Fred Mace, formerly president of the Photoplayers' Club, who organized the Mace Feature Film Company, and has since been to Paris, where he made the feature film of Evelyn Nesbit Thaw, in "Threads of Destiny," is expected in Los Angeles soon. According to rumor, he is to make negatives here for the Lubin Company, which has taken charge of releasing the Thaw feature.

Director J. P. McGowan is now filming the fifth of the railroad series under the general title of "The Hazards of Helen," at the Glendale Kalem studio. This will be entitled, "When the Wires Failed." William C. Ehfe, who played leads for the New York Motion Picture Company, at the canyon studio, near Santa Monica, is playing opposite Helen Holmes in the leads;

(Continued on page 82.)

Make Your Lobby Display Attractive

There is nothing more fascinating to the public than a bright brass frame to display your photos or posters.

We make Lobby and Theatre Fixtures and Brass Rails of every description.

Don't fail to visit our Showrooms. Write for catalog. THE NEWMAN MFG. CO., 717 Sycamore St. Cincinnati, Ohio Branch Factories and Show Rooms: 101 Fourth Ave. New York, N. Y. 106-108 W. Lake St. Chicago, Ill. Established 1882.

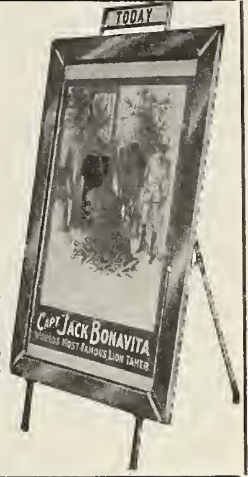

Our Factory Is Yours!

Negative assemblers, projecting machines and an equipment second to none, with an organization of experienced people always at your SERVICE for DEVELOPING and PRINTING.

EVANS FILM MFG. CO. Incorporated

416-22 WEST 216th STREET Tel. 7652 Audubon at Broadway, New York

NO WAR BOOST ON OUR PRICES

Regardless of the present European unpleasantness we continue to use all essential chemicals such as

METOL AND HYDROQUINONE

and consistently maintain standard prices for quality

DEVELOPING AND PRINTING

Send today for our price, quality and service guarantee.

INDUSTRIAL MOVING PICTURE CO. 223-233 West Erie Street, Chicago



ANIMATED SONGS



NOTHING MECHANICAL

NO PHONOGRAPH RECORDS

MOTION PICTURES THAT MOVE TO THE RHYTHM OF SONG

IMPERIAL MOTION PICTURE CO. OF NEW YORK, Inc., 1476 Broadway

Manufacturers of the Wonderful Rembusch Patented Glass MIRROR SCREEN and all other kinds of

Curtains for Moving Picture Projection

GLASS SCREENS

Mirror Screen
Mirror Screen Split
Glass Transparent Screen for Rear Projection

Phone Seven-Eleven

METALLIZED SCREENS

Gold Fibre
Silvercloth
Mirror Cloth
Seamless, with stretchers
White Opaque

E. J. REMBUSCH, Pres.

MIRROR SCREEN COMPANY

Incorporated

SHELBYVILLE, INDIANA

George A. Howard of Monmouth, Ill., exchanged a 9' x 12' "Mirror Screen" bought four years ago for a 12' x 16'. It is as good as new to somebody who wants to buy a Glass "Mirror Screen" right. Eastern Representative, Frank Manning, 125 W. 48th St., N. Y. Phone, Bryant 2416.

HEADQUARTERS FOR POWERS, MOTIOGRAPH, SIMPLEX AND EDISON MACHINES

PICTURE THEATRE EQUIPMENT CO.

THE BIGGEST MOTION PICTURE SUPPLY HOUSE IN AMERICA

21 EAST 14th STREET, NEW YORK CITY

CONDENSERS—BOOTHS—TICKET CHOPPERS—REELS—REEL CASES—BOOTH CABINETS

WE EQUIP MOTION PICTURE THEATRES COMPLETELY

Be sure to mention "THE MOTION PICTURE NEWS" when writing to advertisers.

RECORD OF CURRENT AND COMING RELEASES—Continued

UNIVERSAL PROGRAM

RELEASES OF THE WEEK

Monday, September 28, 1914.

IMP—The Dark Horse, Mary Pickford Reissue, D.
STERLING—The Battle, C., 2000.....
VICTOR—The Proof of a Man, D.....

Tuesday, September 29, 1914.

CRYSTAL—Charlie's Smoke, and Belmont Butts In
GOLD SEAL—Trey o' Hearts (No. 9), D., 2000..
UNIVERSAL IKE—The Shack Next Door, C....

Wednesday, September 30, 1914.

ECLAIR—Till the Sands of the Desert Grow Cold,
D., 2000

JOKER—The New Butler, C.....
NESTOR—The White Wolf, D.....
ANIMATED WEEKLY—No. 133, N.....

Thursday, October 1, 1914.

IMP—The Tenth Commandment, D., 3000.....
REX—The Boob's Legacy.....
STERLING—Title Not Decided.....

Friday, October 2, 1914.

NESTOR—Out of the Frying Pan, C.....
POWERS—The Actress, D.....
VICTOR—The Rock of Hope, D., 2000.....

Saturday, October 3, 1914.

101 BISON—Love and Baseball, C., 2000.....
JOKER—In the Clutches of the Villain, C.....
Barcelona, the Pearl of the Mediterranean, E....

Sunday, October 4, 1914.

ECLAIR—The Man Who Came Back, D.....
FRONTIER—Four Days, D.....
REX—The Pipes of Pan, D., 2000.....

RELEASES OF NEXT WEEK

Monday, October 5, 1914.

IMP—Shadows, D., 2000.....
STERLING—Myers Mistake.....
VICTOR—Disillusioned, D.....

Tuesday, October 6, 1914.

CRYSTAL—Liferitis, C.....
GOLD SEAL—The Trey o' Hearts, Episode 10....
UNIVERSAL IKE—Three of a Kind, C.....

Wednesday, October 7, 1914.

ECLAIR—The Line Rider, D., 2000.....
JOKER—The Baseball Fans in Fanville, C.....
NESTOR—The Old Bell Ringer, D.....

Thursday, October 8, 1914.

IMP—Universal Boy in "Rural Adventures," D...
REX—A Law Unto Herself, D., 2000.....
STERLING—Hypnotic Power, C.....

Friday, October 9, 1914.

NESTOR—He Never Said a Word, C.....
POWERS—The Mayor's Manicure.....
VICTOR—The Woman Who Won, C., 2000.....

Saturday, October 10, 1914.

101 BISON—The Phantom Light, D., 2000.....
JOKER—Cruel, Cruel World, C.....

Sunday, October 11, 1914.

ECLAIR—Cupid Victor, 1000.....
FRONTIER—Dolly's Deliverance, D.....
REX—Virtue Its Own Reward, D., 2000.....

MUTUAL PROGRAM

RELEASES OF THE WEEK

Monday, September 28, 1914.

AMERICAN—Modern Rip Van Winkle, D., 2000..
KEYSTONE—Hard Cider, C., 1000.....
RELIANCE—Our Mutual Girl, No. 37.....

Tuesday, September 29, 1914.

BEAUTY—The Legend of Black Rock, D.....
MAJESTIC—A Mother's Trust, D.....
THANHOUSER—Trail of the Love Lorn, D., 2000

Wednesday, September 30, 1914.

AMERICAN—The Ingrate, D.....
BRONCHO—The Right to Die, D., 2000.....
RELIANCE—Where the Mountains Meet, D....

Thursday, October 1, 1914.

DOMINO—The Gamekeeper's Daughter, D., 2000..
KEYSTONE—Killing Horace, C., 1000.....
MUTUAL WEEKLY—No. 92, N.....

Friday, October 2, 1914.

KAY-BEE—One of the Discard, D., 2000.....
PRINCESS—The Balance of Power, D.....
RELIANCE—The Sheriff's Master, C.....

Saturday, October 3, 1914.

KEYSTONE—Fatty Again, C., 1000.....
RELIANCE—The Wireless Voice, D., 2000.....
ROYAL—Cousin Billy, C.....

Sunday, October 4, 1914.

KOMIC—The Million Dollar Bride, C.....
MAJESTIC—Out of the Air, D., 2000.....
THANHOUSER—A Dog's Love, D.....

RELEASES OF NEXT WEEK

Monday, October 5, 1914.

AMERICAN—Daphnia, D., 2000.....
KEYSTONE—Their Ups and Downs, C., 1000..
RELIANCE—Our Mutual Girl, No. 38.....

Tuesday, October 6, 1914.

BEAUTY—Nieda, D.....
MAJESTIC—The Unpainted Portrait, D.....
THANHOUSER—The Cripple, D., 2000.....

Wednesday, October 7, 1914.

AMERICAN—Billy's Rival, D.....
BRONCHO—The Boss of the Eighth, D., 2000....
RELIANCE—The Badge of Office, D.....

Thursday, October 8, 1914.

DOMINO—The Whiskey Runners, D., 2000.....
KEYSTONE—Hello Mabel, C., 1000.....
MUTUAL WEEKLY—No. 93.....

Friday, October 9, 1914.

KAY-BEE—The Sheriff of Muscatine, D., 2000...
PRINCESS—The One Who Cared, D.....
THANHOUSER—Benevolence of Conductor 786, C

Saturday, October 10, 1914.

KEYSTONE—Those Love Pangs, C., 1000.....
RELIANCE—The Tardy Canon Ball, D., 2000....
ROYAL—The Pet of the Petticoats, C.....

Sunday, October 11, 1914.

KOMIC—Bill Spoils a Vacation (No. 8), C.....
MAJESTIC—The Sands of Fate, D., 2000.....
THANHOUSER—The Rescue, D.....

No matter how thrilling a story one may read, interest is not sustained if poor type, poor paper and poor press work make hard work for the eyes. It's the same with motion pictures. A clear picture is as necessary as a good scenario.

Because the basic product is right, the clearest pictures are on "Eastman" film. Look for the stencil mark in the margin.

EASTMAN KODAK CO.,
ROCHESTER, N. Y.

TITLES

Our *Title Department* has been re-organized, elaborately equipped and placed under the direction of recognized experts.

Its highly perfected apparatus, lino-type machine and job presses enable us to produce the most difficult title work in any language—artistically, accurately and *quickly*—and at *lower prices* than have ever yet been quoted.

DEVELOPING AND PRINTING

Save money and insure the best results by entrusting your work to the *largest and most complete commercial plant in America.*

CENTAUR FILM CO.

Bayonne, N. J., and 1600 Broadway, N. Y.



Our 32-page catalogue No. 3, illustrated in colors, contains a large variety of artificial flowers, vines, garlands, shrubbery, palms, etc. Mailed free for the asking.

FRANK NETSCHERT COMPANY

Manufacturer and Importer of Artificial
Flowers, Natural Prepared Plants, etc.

61 Barclay Street

NEW YORK

No Branch Office.

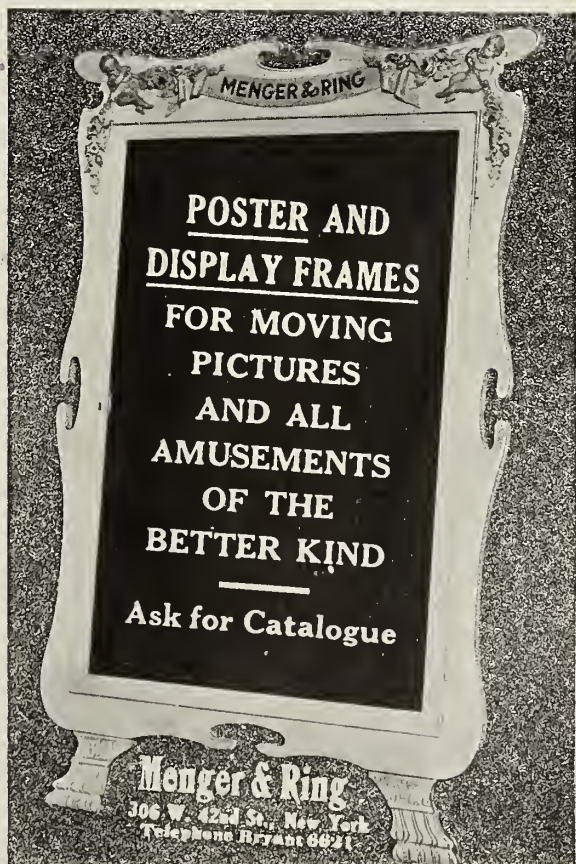

RELEASE DATES FOR READY REFERENCE

GENERAL FILM PROGRAM

Table listing film titles and release dates under categories: BIOGRAPH, COLUMBUS, EDISON, ESSANAY, KALEM, KLEINE, LUBIN.

Table listing film titles and release dates under categories: MELIES, PATHE.

RELEASE DAYS

Table listing film titles and release dates under categories: GENERAL FILM PROGRAM, MUTUAL PROGRAM.

Table listing film titles and release dates under categories: SELIG.

VITAGRAPH

Table listing film titles and release dates under categories: VITAGRAPH, ANIMATED WEEKLY, 101 BISON, CRYSTAL, ECLAIR, FRONTIER, GOLD SEAL, IMP, JOKER.

UNIVERSAL PROGRAM

Table listing film titles and release dates under categories: ANIMATED WEEKLY, 101 BISON, CRYSTAL, ECLAIR, FRONTIER, GOLD SEAL, IMP, JOKER.

THE MOTIOGRAPH

INSTALLED IN YOUR BOOTH

Will Save You TIME, WORRY and EXPENSE

There's a Reason

It's the Best for Projection and Upkeep

The
ENTERPRISE OPTICAL MFG. CO.



Ask the Thousands Using the Late Model

Motiograph

568 W. RANDOLPH STREET
CHICAGO, ILL.

EASTERN OFFICE

21 East 14th Street, New York, N. Y.

WESTERN OFFICE

833 Market Street, San Francisco, Cal.

"Flying A" and American



"Beauty" Feature Films

"JAILBIRDS"

In Two Parts. A Convincing Drama Depicting a Thrilling Western Career.
Under direction of Sydney Ayres. Release Monday, Oct. 12th, 1914.

AMERICAN "BEAUTY" PRODUCTION. Featuring MAGARITA FISCHER and HARRY POLLARD.

"WINSOME WINNIE"

A rattling good comedy sure to please. One and Three Sheet Lithos. Release Tuesday, Oct. 13th, 1914

"DOWN BY THE SEA"

A Love Story Depicting an Unusual Surrender. Under direction of Thos. Ricketts. Release Wed., Oct. 14th, 1914.



Distributed exclusively through the United States and Canada by the Mutual Film Corporation.

AMERICAN FILM MANUFACTURING CO.
CHICAGO

RELEASE DATES FOR READY REFERENCE—Continued

9—23. The Statuesque Beauty, and Jane's Lovers, split reel.....
9—30. The New Butler, C.....
10—3. In the Clutches of the Villain, C.....
10—7. The Baseball Fan in Fanville, C.....
10—10. Cruel, Cruel World, C.....
10—14. On Again, Off Again, Finnigan, C.....

NESTOR

9—4. The Baby Did It, C.....
9—9. A Daughter of the Plains, D.....
9—11. Feeding the Kitty, C.....
9—16. The Danger Line, D.....
9—18. The Troublesome Wink, C.....
9—23. The Half Breed, D.....
9—25. Fruits and Flowers, C.....
9—30. The White Wolf, D.....
10—2. Out of the Frying Pan, C.....
10—7. The Old Bell Ringer, D.....
10—9. He Never Said a Word, C.....
10—16. The Way of Life, D.....

POWERS

9—4. The Storm Bird, C.....
9—11. Angel of the Camp, D.....
9—18. A Modern Melotte, D.....2000
9—25. The Actress, D.....
10—2. The Actress, D.....
10—9. The Mayor's Manicure, C.....
10—16. The Pardrone's Ward, D.....2000

REX

9—10. Helping Mother, D.....3000
9—13.....
9—17. The Mistress of Deadwood Basin, D.....
9—20. A Prince of Bavaria, C.....
9—24. Little Sister, D.....
9—27. As the Wind Blows, D.....2000
10—1. The Boob's Legacy.....
10—4. The Pipes of Pan, D.....2000
10—8. A Law Unto Herself, D.....2000
10—11. Virtue Its Own Reward, D.....2000
10—15. Her Life's Story, D.....
10—18. Kid Regan's Hands, D.....2000

STERLING

9—24. A Shooting Match, C.....2000
9—28. The Battle, C.....2000
10—5. Myers' Mistake.....
10—8. Hypnotic Power, C.....
10—12. The Close Call.....
10—15. Heinie's Outing, C.....

UNIVERSAL IKE

9—22. The "Dear" Hunter, C.....
9—29. The Shack Next Door.....
10—6. Three of a Kind, C.....
10—13. Mary Green's Husband, and Educational, C.....

VICTOR

9—21. Rome, Exhibiting the Vatican and other famous places of the Eternal City.....
9—25. Elsie's Uncle, C.....2000
9—28. The Proof of a Man, D.....
10—2. The Rock of Hope, D.....2000
10—5. Disillusioned, D.....
10—9. The Woman Who Won, C.....2000
10—12. His Father's Son, D.....2000
10—16. The Funny Mr. Dingle, C.....

MUTUAL FILM PROGRAM

AMERICAN

9—28. A Modern Rip Van Winkle.....
9—30. The Brothers.....
10—5. Daphnia.....
10—7. Billy's Rival.....
10—12. Jail Birds, D.....2000
10—14. The Fisherman's Daughter, D.....1000
10—19. In the Daylight, D.....2000
10—21. In the Open, D.....1000

BEAUTY

9—15. The Only Way.....
9—22. Caught in a Tight Pinch.....
9—29. The Legend of Black Rock.....
10—6. Nieda, D.....1000
10—13. Winsome Winnie, C.....1000

BRONCHO

9—30. The Right to Die.....
10—7. The Boss of the 8th.....
10—14. End of the Galley.....
10—21. Shorty and Sherlock Holmes.....

DOMINO

9—17. A Tragedy of the North Woods.....
9—24. The Test of Flame.....
10—1. The Gamekeeper's Daughter.....
10—8. The Whiskey Runners.....
10—15. Jimmy.....
10—22. The Power of the Angelus.....
10—29. Eric the Red's Wooing.....

KAY-BEE

8—18. No-Account Smith's Baby.....
9—25. The Death Mask.....
10—2. One of the Discard.....
10—9. The Sheriff of Muscatine.....2000
10—16. The Word of His People.....2000

KEYSTONE

8—20. Those Country Kids.....
8—22. Caught in a Flue.....
8—24. Fatty's Gift.....
8—27. The Masquerader.....
8—29. Her Last Chance.....
8—31. His New Profession.....
9—3. The Baggage Smasher.....
9—5. A Brand New Hero.....
9—7. The Rounders.....
9—10. Mabel's Latest Prank.....
9—12. Mabel's Blunder, C.....
9—14. All at Sea, C.....
9—17. Bombs and Bangs, C.....
9—19. Lover's Luck, C.....
9—21. He Loved the Ladies, C.....1000
9—24. The New Janitor, C.....1000
9—28. Hard Cider, C.....1000
10—1. Killing Horace, C.....1000
10—3. Fatty Again, C.....1000
10—5. Their Ups and Downs, C.....1000
10—8. Hello Mabel, C.....1000
10—10. Those Love Pangs, C.....1000
10—12. Anglers, C.....1000

KOMIC

9—13. Bill Goes in Business for Himself (No. 6).....
9—20. Foiled Again.....
9—27. Bill Manages a Prize-Fighter (No. 7)
10—4. The Million Dollar Bride.....
10—11. Bill Spoils a Vacation, (No. 8), C.....
10—18. Dizzy Joe's Career.....

MAJESTIC

9—20. Her Awakening.....
9—22. Meg of the Mines.....
9—27. The Great God Fear.....
9—29. A Mother's Trust.....
10—4. Out of the Air.....
10—6. The Unpainted Portrait.....
10—11. The Sands of Fate, D.....2000
10—13. The Warning.....
10—16. Back to the Kitchen.....
10—18. For Her Father's Sins.....2000
10—20. Environment.....
10—25. Paid with Interest.....2000
10—27. A Mother's Influence.....

PRINCESS

8—28. The Keeper of the Light.....
9—4. His Winning Way.....
9—11. Sis.....
9—18. The Master Hand.....
9—25. The Balance of Power.....
10—2. The Balance of Power.....
10—9. The One Who Cared, D.....

RELIANCE

9—16. The High Grader.....
9—19. How the Kid Went Over the Range.....
9—21. Our Mutual Girl No. 36.....
9—23. The Last Shot.....
9—26. The Runaway Freight.....
9—28. Our Mutual Girl No. 37.....
9—30. When the Mountains Meet.....
10—2. The Sheriff's Master.....
10—3. The Wireless Voice.....
10—5. Our Mutual Girl, No. 38.....

10—7. The Badge of Office.....
10—10. The Tardy Canon Ball.....2000
10—12. Our Mutual Girl (No. 39).....
10—14. Bad Man Mason.....
10—17. The Revenue Officer's Deputy.....2000

ROYAL

9—5. O'Flanagan's Luck.....
9—12. The Prodigal Husband.....
9—19. The Horse Trader.....
9—26. Scarecrow.....
10—3. Cousin Bill.....
10—10. The Pet of the Petticoats.....

THANHOUSER

8—18. McCarn Plays Fate.....2000
8—25. A Dog's Good Deed.....
8—30. Art the Artist.....
9—1. A Mother's Choice.....2000
9—6. Little Mischief.....
9—8. Jean of the Wilderness.....2000
9—11. In Danger's Hour.....
9—13. The Emperor's Spy.....
9—15. Gold.....
9—20. The Mettle of a Man.....
9—22. The Varsity Race.....
9—27. The Harvest of Regrets.....
9—29. The Trail of the Love Lorn.....
10—4. A Dog's Love.....
10—6. The Cripple.....
10—9. The Benevolence of Conductor 786
10—11. The Rescue.....
10—13. The Diamond of Disaster.....2000

INDEPENDENT RELEASES

ECLECTIC FILM COMPANY

Max Has the Boxing Fever, C.... 560
Picturesque Lake Dahl, British India, Scenic..... 400
In Soak, C.....
A Prince of India, D.....
Pathé Daily News No. 64-1914, Top Second Door Left, C.....
Pathé Daily News No. 65, Top.....
Perils of Pauline, No. 14, D.....
Colonel Heeza Liar in the Wilderness, C..... 700
Strange Animals, E..... 300
Pathé Daily News No. 62-1914, Top.
The Colonel's Wife, D.....
Pathé Daily News No. 63-1914, Top.

FILMS LLOYD

5—7. Cora, the Temptress.....3900

GREAT NORTHERN SPECIAL

5—5. The Monomaniac.....3000

PICTURE PLAYHOUSE FILM COMPANY

7—29. Lupin.....3000
8—10. The Oath of a Viking.....3000
8—19. The Next in Command.....4000
8—26. The Film Detective.....4000
9—5. The Poison Pool.....5000

ANIMATED SONGS

Imperial Motion Picture Co., New York
Releases for August:

A Fool There Was.
Take Me Back to Frisco Town.
Shadows.
Father Came Home with the Milkman in the Morning.
Dear Old Girl.
What a Wonderful Love That Would Be.
When I Dream of Killarney.
Down in Our Old Country Town.
In the Valley of the Moon.
Let's Go Back to Sweetheart Days.
Just a Black Sheep That Strayed from the Fold.
Let Us Kiss and Make Up Again.
There's a Lonesome Little Girl in a Lonesome Little Town.
She Was My Dad's First Sweetheart.
Down Where the Old Road Turns.
Push It Along.
She's Just a Bird in a Gilded Cage.

"IRELAND, A NATION"

(Macnamara Feature—Five Reels)

REVIEWED BY PETER MILNE

WALTER MACNAMARA, the writer and director of "Ireland, A Nation," has produced a picture, the like of which has never been seen before. It faithfully depicts the struggles that Ireland experienced in regaining her parliament since the time she lost it in the latter part of the eighteenth century until only a few months ago when the Home Rule bill was passed.

Some of the time has been skimmed over lightly, but the age that the noted Irish patriot, Robert Emmet, lived and fought for his country, is portrayed with great attention to detail.

From the way in which the picture was received at the Forty-fourth Street Theatre, New York City, by an audience made up of patriotic sons of the Emerald Isle, the picture is bound to be a success. No more successful picture could be shown to the Irish, from a box office standpoint. But, Mr. Exhibitor, if you believe in the "Safety First" proposition, warn all Englishmen, Orangemen and the opposition to the Home Rule bill to stay out, or else there will be quite a riot.

When an audience consisting of Irishmen cheer for every subtitle which favors their country, hiss at the others, applaud each time the heroes make their appearance and roundly hiss the opposition, it is a fair decision to make that the picture will score a great success, with that nationality.

An introductory reel preceded the picture proper at the Forty-fourth Street Theatre, showing various scenes in Ireland, and from the reception that these scenes received it is evident that they were familiar to most of those present.

The picture then starts, showing the defeat of the Irish patriots in an effort to retain their parliament, by Castlereagh, who bought many of his votes. Then the activities of Robert Emmet commence, and cease not until he is hanged by the English.

His words uttered at the trial, "Let no man write mine epitaph until Ireland has taken her place among the nations of the world," are placed on his tomb, and then when the Home Rule bill has been passed we see the inscription being written and his wish at last granted.

Although the value of the picture lies in its historical teachings, it is a worthy scenic besides. It is photographed well throughout; some very pretty views have been caught. It was made in Ireland of course and the principals and extras are all Irish.

Barry O'Brien plays Robert Emmet, and is about the most important in the cast in the first part of the picture. Daniel O'Connell, who continued the work of Emmet, many years after his death, is played by Franklyn Hanna. The women in the cast are Annie Purcell and Lillian Leach.

ORGANIZATION FINDS FAVOR IN IDAHO

Special to THE MOTION PICTURE NEWS

Boise, Idaho, Sept. 29.

BELIEVING that in organization there is strength and that much could be done toward the betterment of the business if the exhibitors in Idaho were organized and could affiliate with the Motion Picture Exhibitors' League of America, is the position taken by the local exhibitors relative to the national organization, although but few of them are familiar with its workings or what it has accomplished.

It is not believed that it would be possible to perfect a state organization in Idaho, as the cities and towns having motion pictures are so scattered and the expense is so great in getting from one town to another. Some of the proprietors express a hope that a Southern Idaho exhibitors' association can be organized and it is likely that a move in that direction may be made within a few months.

WAR PICTURES

Be the first. Photographs of "World's Greatest War" taken from life—Not Newspaper Cuts. Our MR. HUBRELL is in the War Zone. By special arrangements with several foreign associations, we are supplied with the latest original and up-to-date copyrighted photographs. Title is on bottom of each slide and also a separate descriptive lecture. Issued in series of 14 colored slides. Price, each series, including large poster, \$2.75. Extra Posters 5 cents each. Flags of nations, portraits of Monarchs and important officials in war zone, set of 10 each, \$2.50 a set, or 35 cents each. A hooster for your business.

MOORE, HUBBELL & CO. Masonic Temple, Chicago

THE ALBUQUERQUE FILM MFG. COMPANY, Inc.

Featuring that clever
Comedienne

Miss Dot Farley

Two Comedies Weekly

RELEASING THROUGH
The United Motion Picture Producers, Inc.
WHO DISTRIBUTE THROUGH
Warner's Features, Inc.

By request from many exchanges
we take pleasure in
reviving the

**FRONTIER
TWIN STORIES**

Written and made famous by Miss Dot
Farley. Under direction of
Gilbert P. Hamilton

Farce Comedy Production

BY

ARCHER McMACKIN

Nuf Sed

WESTERN STUDIO

406 Court St. Los Angeles, Calif.

GILBERT P. HAMILTON, Pres. and Gen. Mgr.

Your Show Window

Perhaps you do not realize it, but your lobby is the Show Window of your theatre, and your attractions will be judged by your display.

Announcement

We are now sole authorized manufacturers and sales agents for lobby photos, by exclusive contract with

THE GENERAL FILM COMPANY

Also sole authorized manufacturers and sales agents for lobby photos, by exclusive contract with

THE UNIVERSAL FILM MANUFACTURING COMPANY

The reason is because we make the best and the manufacturers will sanction nothing else.

11 x 14, Suitable for framing (Sepia), \$1.50 per doz.

22 x 28, Suitable for framing (Sepia), 40c. each.

22 x 28, Suitable for framing, Hand Colored, \$1.00 each.

Send us your order: If your pictures are not miles ahead of any pictures on the market, return them at our expense.

Have you heard of our coupon plan? If not—write us.

Wyanoak Publishing Co.

136-146 West 52d Street

NEW YORK, N. Y.

"GOD, MAN AND THE DEVIL"

(Warner's-Mittenthal—Five Reels)
REVIEWED BY PETER MILNE

MANY pictures have been produced that deal with the reformation of the prodigal son of the family, but here just after his ways seem to have been mended for all time, the young man lapses into his evil habits again and before he has a chance to begin the process of reforming for the second time, death overtakes him.

With this finale, although not exactly pleasant, the production may be termed unhackneyed, at the least. The outcome, which is tragic, seems a good deal more probable than one in which a man's reformation is brought about in a few days, saved from the downward path by



"COME BACK WITH ME AND APOLOGIZE"

the smile of some girl, or because his immediate environment prevents his carousing at will.

In other words, the man in this picture seems more human than the other one, which again makes the story more real. It is just a case of a man being too far gone in his evil ways to stop and go back. He is a man to be pitied, but the situation is human, and not unlikely to occur.

But there is another side to the picture, one that will not pass unnoticed. The scenes laid in the north woods are unmistakably in the north. Just where is not known, but several feet of snow are on the ground, the pine trees are laden with it; a number of sledge dogs are introduced, and a number of other smaller things all appear to stamp it as a real northern location.

Then again the scenes in the lumber camp, with the woodsmen cutting down the lofty pines and sawing them up into logs will surely create added color. Most of the action transpires in these parts, where the son has been sent, and they form a striking contrast to the fewer scenes that appear taken in the rooms of city houses, offices and cabarets.

Although the picture is all very fine in these points, there are some things which might be perfected. The subtitle, "The Next Day," appears several times in one reel, with very few others between. This may be corrected. A long introduction precedes the entrance of the smuggler and his daughter into the story. Full of thrills, chases with a little shooting, which make it duly entertaining, but not exactly necessary.

After the son has wasted his father's money in the cafes, and forged a check, he is sent to the north woods. Here he gets along tolerably well for a time, but meeting with the daughter of the smuggler, it is as if she bewitched him, and all his evil returns. His friend tells him to beg the pardon of the girl whom he insulted, and he, refusing to accede to the command, is pursued for his refusal and falls down a steep declivity to his death. This utter disregard of the usual exercise of "poetic justice" has a touch of the grim realism, and the inexorable logic of a Hardy novel, where a man's sins find him out, and make him pay the penalty to the full.

Cosmos Features

**STATE RIGHT BUYERS
HAVE YOU ARRANGED FOR YOUR TERRITORY?
THE STAR**



The Play
"Lena Rivers"
IN FIVE PARTS

The Time
Released Oct. 15

BEULAH POYNTER

Cosmos Feature Film Corporation

126-130 WEST 46th STREET, NEW YORK

LUBIN

THE PRODUCER OF MASTERPIECES

EVERY EXHIBITOR SHOULD BOOK THESE EXCEPTIONAL FEATURES

(Through the General Film Special Service)

WILLIAM ELLIOTT, Late Star of "Madame X"
Company

"THE FORTUNE HUNTER"
6 Reels By Winchell Smith Produced by Barry O'Neil

"MARAH THE PYTHONESS"
3 Reels By Clay M. Greene Produced by Joseph W. Smiley

READY FOR EARLY RELEASE
EVELYN NESBIT THAW
and her son, **RUSSELL WILLIAM THAW** in
"THREADS OF DESTINY"

5 Reels By William H. Clifford Produced by Joseph W. Smiley

EDWIN ARDEN

5 Reels **"EAGLE'S NEST"** Produced by
By Edwin Arden Romaine Fielding

RAYMOND HITCHCOCK In a 5 Reel Comedy Drama
Produced by George Terwilliger
by Lawrence McCloskey

IN PREPARATION
ROSE COGLAN

And **ETHEL CLAYTON** in
"THE SPORTING DUCHESS"
6 Reels By Cecil Raleigh Produced by Barry O'Neil

SIX REGULAR RELEASES EACH WEEK

- | | | |
|--|------------|--------------|
| "THE BELOVED ADVENTURER"
4th of Series, "AN AMERICAN HEIRESS" } Drama | Monday, | October 5th |
| "A HUNTING ABSURDITY" | Tuesday, | October 6th |
| "WIFIE'S ATHLETIC MAMMA" Split Reel Comedies | Wednesday, | October 7th |
| "THE GIRL AT THE LOCK"—Two Reel Drama | Thursday, | October 8th |
| "IN OLD VIRGINIA"—Two Reel Drama | Friday, | October 9th |
| "THE GREEN EYED MONSTER"—Drama | Saturday, | October 10th |
| "WHEN THE HAM TURNED"—Comedy | | |

SPECIAL ONE, THREE AND SIX SHEET POSTERS.

Lubin Manufacturing Company, Philadelphia, Pa.

Chicago Office:
154 West Lake Street



ALL STAR FEATURES

ETHEL BARRYMORE
in "The Nightingale"

By Augustus Thomas Five Reels

COMING

DIGBY BELL

in

"The Education of Mr. Pipp"

By Augustus Thomas Five Reels

James A. Herne's

SHORE ACRES

Five Reels

All Star Feature Corp.

220 West 42d Street New York

Your negative developed, printed and titled complete

5c per foot delivered within **12** hours

Titles **6c** per foot

GUNBY BROS., Inc.

145 West 45th Street New York City

FURNITURE & FURNISHINGS

On RENTAL

We equip your settings complete in accordance with your scenario.

WILLIAM BIRNS

103-105 West 37th St.

Phone: Greeley 6255.

LANG'S FILM REELS

THE BEST MADE

14 in. \$1.50 10 in. \$1.00

CATALOGUE

LANG MFG. WORKS, Orleans, N. Y.

NOW RELEASED

THE LITTLEST REBEL

Should A Woman Tell?

A splendid big feature is proving the biggest hot weather attraction on the market. It played to big success for months on Broadway. For bookings write now to

THE PHOTOPLAY PRODUCTIONS
RELEASING COMPANY

37 S. Wabash Ave. Chicago, Ill.

A. L. Runyon Advertising & Sales Co., Inc., Successors to



Prices to The Trade

POSITIVE PRINTS .04½ Per Foot
(In Quantities over 5000 feet)

Above price includes printing, developing, tinting, toning and Raw Positive
Negative Film Developed .01 Per Ft.
Film Titles .08 " "

(Our Special Title Apparatus will match any perforation.) All work guaranteed.

General Offices, 2624 Milwaukee Ave., Chicago
Phone Albany 3125

In and Out of Los Angeles Studios

(Continued from page 73.)

George Williams is playing the character part, and Paul Hurst the heavy leads.

Unable to secure all the pictures of circus life for the film production of "The Rose in the Ring," while the Barnum and Bailey circus was recently here, Director Cecil De Mille and Company of Lasky players followed the show to several nearby cities.

As the managers refused to permit pictures to be made of the interior of the tents, the Lasky company decided to put on a regular circus of its own, using the vacant lot near the studio for this purpose.

Bad Scare for Apfel

While at Rosamond, where the Tropico gold mines were used for several scenes, Director Oscar Apfel, producing "Ready Money," backed into a shaft of the mine, following an explosion, in order to get out of the smoke.

He found he had walked ahead of all the gases and fumes from the burned explosives, as it was drawn into the section he entered by a back draft. It became so dark he could not see. He stumbled about, and finally succeeded in crawling to the entrance, where he was found by other members of the company. He was taken outside and soon recovered.

Director Eddie Dillon has completed number nine of the Bill series, entitled "Bill Joins the W. W. W.'s." The real meaning of the initials significant of a well-established order was "We Want Work," but Bill, before becoming a member, translated the meaning to be "We Won't Work," and he didn't work.

While making this picture Tam Young, who plays the part of Bill, attempted to buy a package of cigarettes at a Venice cigar stand, but the proprietor informed him he could not sell to boys under twenty-one under penalty of fine and imprisonment. Mr. Dillon explained that Tam was old enough to have two or three sons in the soldiers' home at Sawtelle, a suburb of Los Angeles.

One Big Studio for all Companies

Gilbert P. Hamilton, president and general manager, and H. F. Connelly, vice-president, of the Albuquerque Film Manufacturing Company, have arrived home from New York, where they attended the United Motion Picture Producers' Organization meeting.

But two companies are now producing at the Balboa studio at Long Beach, owing to Director Bertram Bracken taking a vacation which began September 21.

The Albuquerque Company will make two thousand feet weekly, consisting of one comedy and one two-reel subject monthly. Later it expects to make multiple reel features as they are needed.

"American" Motion Picture Cameras**AT THE FRONT**

Our famous Improved No. 2 Camera on the fring line at "Vera Cruz."

"AMERICAN" products are always with the Advance Guard. The world's most important motion pictures are taken with "AMERICAN" CAMERAS.

Agents for AGFA and GEVAERT Raw Motion Picture Film.

Send for Catalogue C.

American Cinematograph Co.

617-631 W. Jackson Blvd., Chicago, Ill.

"New Film For Old"



Films Improved, Cleansed and Softened

Multicolor Film Improving Co., Inc.
15 East 26th Street New York
Philadelphia Branch
1126 Vine Street Albert Teitfl President

"EVERYONE'S USING"**Our Developing Tank System**

Get No. 6 Price List

A. J. CORCORAN, Inc.

9½ John Street New York

PRINTING, DEVELOPING AND FILM TITLES

All Work Guaranteed—Prompt Service.
We can furnish an expert camera man if you have some special event to be photographed. Our prices are right. A trial will convince you.

STANDARD MOTION PICTURE CO.
Tel. Randolph 839 5 S. Wabash Av., Chicago

LE COURRIER

Cinematographique

28 Boulevard St. Denis, Paris

Directeur: Charles LE FRAPER

Journal hebdomadaire français, le plus important de l'industrie cinématographique.

Envoie numéro spécimen, sur demande.
Abonnement 12 FR. 50

THE CHEAPEST PLACE

TO BUY BEST QUALITY

ROLL TICKETS

IS

The Pioneer Ticket Co.

722 Broadway, New York

Perfect Numbering Quick Delivery

“BE NEUTRAL” ON THE WAR **BUT** **NOT on the MORGAN POSTER Question**

What **You, Mr. Exhibitor**, might say or do will not influence the fearful conflict in Europe one iota. Your concern should be centered on your business—Your war is one of competition and what you can and should do in preparing yourself will have a mighty bearing on results. **The UNIVERSAL FILM MANUFACTURING CO., as your staunchest Ally, has prepared, in conjunction with The MORGAN LITHOGRAPH CO.,**

ONE, THREE AND SIX SHEET POSTERS

Of unparalleled excellency. These **POSTERS** decorating your theatre front and used wherever possible, will be one of your best armaments against dull business—against failure. The health, the safety of your business demands, if you haven't already adopted them, that you **GET BUSY.**

Every Poster has a thrill in it. **Every one** is made in six colors; every one is an artistic achievement that can not fail to draw the crowd into your house.

A SPECIAL WAR MAP

A one sheet map correct in every detail, made especially for you by the enterprising **MORGAN LITHOGRAPH CO.** It is so arranged that if mounted on beaverboard, the exact location of the warring armies can be shown by means of colored push buttons or flags. **THIS IS SOMETHING EXTRA.**

Give your lobby the same attraction which draws vast crowds before every newspaper office in the world. Put one of these special **WAR MAPS** in your lobby. The effect will be instant and tremendous. People must know how the various armies are progressing. Nothing better as an advertising stunt.

ORDER YOUR POSTERS and WAR MAPS IMMEDIATELY. Safeguard yourself against competition.

You can get **MORGAN POSTERS** from your **Exchange**

OR WRITE TO

THE MORGAN LITHOGRAPH CO., Cleveland, Ohio

OR

Service Department

Universal Film Manufacturing Co.

1600 Broadway

CARL LAEMMLE, Pres.

New York, N. Y.

Webb Detective Series

Second Release

"THE MAN IN THE CELLAR"

Better Than

"The Black Triangle"

Distributors

EXCLUSIVE FEATURES, INC.....71 West 23rd Street, N. Y. City.
GERONIMO FEATURES & ENTERPRISES..Stamford, Conn.
ROYAL AMUSEMENT COMPANYSan Antonio, Texas.
TRI-STATE FEATURE FILM CO.....710 E. Baltimore Street, Baltimore, Md.
EXHIBITORS F. F. CO.....413 Summit Street, Toledo, Ohio.
EMPRESS FEATURE FILM CO.....1517 Merchant Bank Bldg., Indianapolis, Ind.
GOLGATE FILM EXCHANGE.....234 Eddy Street, San Francisco, Cal.
GOLGATE FILM EXCHANGE.....514 W. 8th Street, Los Angeles, Cal.
NORTHWESTERN F. F. CO.....1216 Third Avenue, Seattle, Washington.
WOLVERINE FEATURE FILM CO.....17 Campau Bldg., Detroit, Michigan.
LIBERTY FILM RENTING CO.....105 Fourth Avenue, Pittsburgh, Pa.
GENERAL FEATURE FILM CO.....5 S. Wabash Avenue, Chicago, Illinois.
HERRICK FEATURE FILM CO.....807 Observatory Bldg., Des Moines, Iowa.
ALLFEATURES, INC.....56 King Street, West, Toronto, Canada.

FILMS LLOYDS, INC.

220 W. 42nd Street

N. Y. City

OCTOBER 17, 1914

Motion Picture News

HAS THE QUALITY CIRCULATION OF THE TRADE

HAVE YOU \$100 TO THROW AWAY?

SEE PAGE 17

LASKY

LASKY

PARAMOUNT
PICTURES



JESSE L. LASKY
PRESENTS

Mr. ROBERT EDESON

IN HIS FAMOUS CHARACTER "HOW LANDER" IN

**"WHERE THE
TRAIL DIVIDES"**

A FIVE PART
ROMANTIC DRAMA

RELEASED OCT. 12th

LASKY
LASKY

JESSE L. LASKY FEATURE PLAY COMPANY

LONG ACRE THEATRE WEST 48TH STREET, N.Y.C.

JESSE L. LASKY SAMUEL GOLDFISH CECIL B. DE MILLE

PRESIDENT TREAS. & GENL. MANAGER DIRECTOR GENERAL



THE TREY O HEARTS



BY LOUIS JOSEPH VANCE

THE MASTER PROBLEM PLAY
IN FIFTEEN STORIES

STANDARD BOOK CO. NEW YORK

FEATURING
CLEO MADISON & GEO LARKIN

WITH IRENE LUCAS





TODAY'S EVENTS

are the biggest, most momentous, stirring and important events that have ever happened in the history of the world. In future years many a photo-play will be written with these events as a basis, but no fiction play can ever have such vital interest and such an irresistible pulling power as the events themselves, caught by the camera and preserved forever in

THE PATHÉ DAILY NEWS

What will appear to your grandchildren as the greatest chapter of history can be seen today by your patrons as a chapter of actual life. The Pathé News goes everywhere—gets everything. The Pathé photography is perfect.

The Pathé Daily News (issued semi-weekly) may now be obtained through the Eclectic Feature Film Exchanges.

ECLECTIC FEATURE FILM EXCHANGES FOR YOUR USE

- | | | | | |
|------------------------------------|-------------------------------|--------------------------------------|-------------------------------------|--------------------------------|
| ATLANTA
61 Walton St. | DALLAS
Andrews' Bldg. | MINNEAPOLIS
4th and Hennepin Sts. | PHILADELPHIA
1235 Vine St. | SAN FRANCISCO
67 Turk St. |
| BOSTON
3 Tremont Row | DENVER
Nassau Bldg. | NEW ORLEANS
910 Gravier St. | PITTSBURGH
715 Liberty Ave. | SEATTLE
810 Third Ave. |
| CHICAGO
5 So. Wabash Ave. | KANSAS CITY
928 Main St. | NEW YORK
115 E. 23rd St. | PORTLAND
392 Burnside Ave. | ST. LOUIS
3210 Locust St. |
| CINCINNATI
217 E. 5th St. | LOS ANGELES
114 E. 7th St. | OMAHA
1312 Farnam St. | SALT LAKE CITY
68 South Main St. | SYRACUSE
214 D. Fayette St. |
| CLEVELAND, 622 Prospect Av., S. E. | | | WASHINGTON, 7th & E Sts., N. W. | |

THE ECLECTIC

110 West 40th Street



FILM COMPANY

New York City

"The Cream of American and

European Studios"





The Headliner *Everywhere*

Throughout the United States and Canada —at the better theatres *everywhere*—The Million Dollar Mystery is a headliner. No other motion picture production vies with it for this honor. *It leads!* And this supremacy is due to the exceptionally high quality of the picture—to the fine photography, the interesting plots and the wonderful acting.

THE MILLION DOLLAR MYSTERY

Story by Harold MacGrath

Scenario by Lloyd Lonergan

Thanhouser's Million Dollar Motion Picture Production

Exhibitors: Episode No. 17 has just been released. The story is complete in 23 episodes. A two-reel episode is released each week. The story by Harold McGrath is now appearing in 300 of the leading newspapers. \$10,000.00 will be paid for the best 100-word solution of the mystery. Bookings on *all* episodes are now being arranged. Apply to

SYNDICATE FILM CORPORATION

71 West 23rd Street, New York

Room 411, 5 S. Wabash Avenue, Chicago

or Syndicate Film Corporation Representative at any Mutual Exchange in the United States and Canada

THE THANHOUSER THREE-A-WEEK

Tuesday, Oct. 13. "The Diamond of Disaster." (Two reels.) A strong drama played by an exceptional cast, including Irving Cummings, Carey L. Hastings, J. S. Murray, Ernest Ward, Daniel H. Thompson and Justus D. Barnes.

Sunday, Oct. 18. "Left in the Train." One-reel drama featuring Mildred Hellar, Virginia Waite, J. S. Murray and the Thanhouser twins—Madeline and Marion Fairbanks.

THANHOUSER FILM CORPORATION, New Rochelle, N. Y.

Head European Office, Thanhouser Films, Ltd., London, W. C., England

Regular Thanhouser releases are distributed exclusively in the United States and Canada by the Mutual Film Corporation.



MASTERPIECE FILMS

MASTERPIECE FILMS

MR. MAX FIGMAN

Supported by

MISS LOLITA ROBERTSON

in

"THE HOOSIER SCHOOLMASTER"

(FIVE REELS)

By **EDWARD EGGLESTON**

TO BE RELEASED OCTOBER 22

Write or wire for reservations

Attractive paper consisting of three one-sheet, two three-sheet, one six-sheet and one twenty-four-sheet.



Aside from "Uncle Tom's Cabin" and "Les Miserables," "The Hoosier Schoolmaster" is probably more widely read by the American public than any other novel.

The production of the film version of this work is thoroughly in keeping with the greatness of the subject.

M. DE LA PARELLE, Producer
ELLIOTT J. CLAWSON, Assistant Producer

Address all communications to

MASTERPIECE FILM MANUFACTURING CO.

1111 Van Nuys Building, Los Angeles, Cal.

MASTERPIECE FILMS

MASTERPIECE FILMS



PARAMOUNT

The FAMOUS PLAYERS HALF YEAR'

(DISTRIBUTED THROUGH

CURRENT RELEASES:

PRODUCTIONS

THE LOST PARADISE - - - - -
 THE UNWELCOME MRS. HATCH - - - - -
 SUCH A LITTLE QUEEN - - - - -
 MARTA OF THE LOWLANDS - - - - -
 WILDFLOWER - - - - -

ARTISTS

H. B. WARNER
 HENRIETTA CROSMAN
 MARY PICKFORD
 MME. BERTHA KALICH
 MARGUERITE CLARK

These productions have been recorded in the annals of the industry as distinctive film achievements.

FORTHCOMING ATTRACTIONS:

- | | |
|--|------------------------|
| THE COUNTY CHAIRMAN
Henry W. Savage's comedy drama triumph, by George Ade
Released Oct. 26th | MACLYN ARBUCKLE |
| HIS LAST DOLLAR
the famous racing play, with the star in his original role
Released Oct. 29th | DAVID HIGGINS |
| BEHIND THE SCENES
the noted play of theatrical life by Margaret Mayo
Released Nov. 2nd | MARY PICKFORD |
| THE MAN FROM MEXICO
H. A. Du Souchet's famous comedy
Released Nov. 9th | JOHN BARRYMORE |
| THE STRAIGHT ROAD
the master-work of the distinguished dramatist, Clyde Fitch
Released Nov. 12th | GLADYS HANSON |
| ARISTOCRACY
the dramatic success of two decades, by Bronson Howard
Released Nov. 26th | TYRONE POWER |
| MRS. BLACK IS BACK
the distinguished comedienne's foremost comedy success, by George V. Hobart
Released Nov. 30th | MAY IRWIN |
| THE STEPSISTER
a genuine and delightful surprise—a Pickford classic
Released Dec. 21st | MARY PICKFORD |

AN UNPARALLELED SERIES
PRODUCED

FAMOUS PLAYERS

ADOLPH ZUKOR, President
 DANIEL FROHMAN, Managing Director
 EDWIN · S · PORTER, Technical Director





FAMOUS-PLAYERS FILM CO'S PROGRAM

(PARAMOUNT PICTURES CORP.)

FORTHCOMING ATTRACTIONS (Continued):

- | | | |
|-------------------------------|--|--------------------------|
| SOLD | the great emotional drama, Pauline Frederick's first film appearance
Released Dec. 28th | PAULINE FREDERICK |
| THE MILLION | second Famous-Players Savage production
Released Dec. 31st | EDWARD ABELES |
| THE CONSPIRACY | the dramatic triumph of the last theatrical season, with its original star
Released Jan. 7th | JOHN EMERSON |
| THE CRUCIBLE | the powerful and world-famous story by Mark Lee Luther
Released Jan. 18th | MARGUERITE CLARK |
| THE DANCING GIRL | the celebrated emotional drama by Henry Arthur Jones
Released Jan. 25th | FLORENCE REED |
| MISTRESS NELL | the renowned romantic play by Geo. C. Hazelton, Jr.
Released Feb. 1st | MARY PICKFORD |
| THE LOVE ROUTE | the recent successful dramatic romance
Released Feb. 4th | HAZEL DAWN |
| HER TRIUMPH | the celebrated international star's first and exclusive film appearance
Released Feb. 8th | GABY DESLYS |
| THE SIGN OF THE CROSS | a stupendous and spectacular film version of Wilson Barrett's immortal drama
Released Feb. 21st (Lent) | WILLIAM FARNUM |
| THE COMMANDING OFFICER | an adequate representation of the great military drama
Released Feb. 25th | JULIAN L'ESTRANGE |

OF FILM TRIUMPHS
BY THE

FILM COMPANY

Executive Offices
213-229 WEST 26TH ST.
NEW YORK





FAMOUS PLAYERS FILM CO.

In Association with Daniel Frohman Chas. Frohman ~ Henry W. Savage



THE PRODUCTIONS OF

JESSE L.

Associated David The Liebler



Paramount

Releases for First Three Months

Date.	Maker.	Play.	Star.
Monday, Aug. 31	Famous Players	"The Lost Paradise"	H. B. Warner.

SEPTEMBER

Thursday, Sept. 3	Bosworth	"Odyssey of the North"	Bosworth.
Monday, " 7	Lasky	"Virginian"	Dustin Farnum.
Thursday, " 10	Famous Players	"Unwelcome Mrs. Hatch"	Henrietta Crosman.
Monday, " 14	Bosworth	"Burning Daylight"	Bosworth.
Thursday, " 17	Lasky	"Bobby Burnit"	Edward Abeles.
Monday, " 21	Famous Players	"Such a Little Queen"	Mary Pickford.
Thursday, " 24	Deutsche Bioscope Co.	"William Tell"	Karl Kienlechner.
Monday, " 28	Oz Film Co.	"Patchwork Girl of Oz"	Couderc.

OCTOBER

Thursday, Oct. 1	Bosworth	"Pursuit of Phantom"	Bosworth.
Monday, " 5	Famous Players	"Marta of the Lowlands"	Bertha Kalich.
Thursday, " 8	Paramount Pictures Corp.	"The Typhoon"	Sessue Hayakawa.
Monday, " 12	Lasky	"Where the Trail Divides"	Robert Edeson.
Thursday, " 15	Famous Players	"Wildflower"	Marguerite Clark.
Monday, " 19	Bosworth	"The Hypocrite"	Courtenay Foote.
Thursday, " 22	Lasky	"What's His Name"	Max Figman and Lolita Robertson.
Monday, " 26	Famous Players	"The County Chairman"	Maclyn Arbuckle.
Thursday, " 29	Famous Players	"His Last Dollar"	David Higgins.

NOVEMBER

Monday, Nov. 2	Famous Players	"Behind the Scenes"	Mary Pickford.
Thursday, " 5	Lasky	"Ready Money"	Edward Abeles.
Monday, " 9	Famous Players	"The Man from Mexico"	John Barrymore.
Thursday, " 12	Famous Players	"The Straight Road"	Gladys Hanson.
Monday, " 16	Lasky-Belasco	"The Rose of the Rancho"	Bessie Barriscale.
Thursday, " 19	Lasky	"The Ring Master"	Theodore Roberts.
Monday, " 23	Bosworth	"Chechako"	Bosworth.
Thursday, " 26	Famous Players	"Aristocracy"	Tyrone Power.
Monday, " 30	Famous Players	"Mrs. Black Is Back"	May Irwin.

Productions of these foremost manufacturers released selections from the WRITE YOUR NEAREST EX

Paramount Pict

ONE HUNDRED and TEN WEST NEW YO



LASKY FEATURE
PLAY CO.

ed with
Belasco
Company
CONSTITUTE



BOG WORTH INC.

Producers of
Jack London's
Fiction Classics

Pictures

Releases for Second Three Months

DECEMBER

Date.	Maker.	Play.	Star.
Thursday, Dec. 3...	Open		
Monday, " 7...	Lasky	"Ghost Breakers"	H. B. Warner.
Thursday, " 10...	Open		
Monday, " 14...	Lasky-Liebler Co.	"The Man from Home"	Charles Richman.
Thursday, " 17...	Smalleys	"False Colors"	Lois Weber.
Monday, " 21...	Famous Players	"Step Sister"	Mary Pickford.
Thursday, " 24...	Lasky-Liebler Co.	"Cameo Kirby"	Dustin Farnum.
Monday, " 28...	Famous Players	"Sold"	Pauline Frederick.
Thursday, " 31...	Famous Players	"The Million"	Edward Abeles.

JANUARY

Monday, Jan. 4...	Lasky-Belasco	"The Governor's Lady"	*
Thursday, " 7...	Famous Players	"The Conspiracy"	John Emerson.
Monday, " 11...	Lasky-Belasco	"Girl of the Golden West"	All Star Cast.
Thursday, " 14...	Smalleys	"Aurora Leigh"	Lois Weber.
Monday, " 18...	Famous Players	"The Crucible"	Marguerite Clark.
Thursday, " 21...	Lasky	"The Goose Girl"	*
Monday, " 25...	Famous Players	"The Dancing Girl"	Florence Reed.
Thursday, " 28...	Lasky-Liebler	"Merely Mary Ann"	*

FEBRUARY

Monday, Feb. 1...	Famous Players	"Mistress Nell"	Mary Pickford.
Thursday, " 4...	Famous Players	"The Love Route"	Hazel Dawn.
Monday, " 8...	Famous Players	"Her Triumph"	Gaby Deslys.
Thursday, " 11...	Bosworth (Van Loan)	"Little Sunset"	*
Monday, " 15...	Lasky-Belasco	"The Warrens of Virginia"	*
Thursday, " 18...	Lasky	"The Country Boy"	*
Monday, " 22...	Famous Players	"The Sign of the Cross" (Lent)	William Farnum.
Thursday, " 25...	Famous Players	"The Commanding Officer"	Julian L'Estrange.
Monday, Mar. 1...	Lasky-Belasco	"The Woman"	*

* Star to be announced later.

exclusively through Paramount Program, and
world's markets beside
CHANGE FOR INFORMATION

ures Corporation

FORTIETH STREET
RK, N. Y.





The Matinee Problem
Solved at Last!

OZ FEATURES

Appeal Strongly to Adults
and Children as Well.

Grown Folks Crowd the Evening Per-
formances — Children Keep Matinees
Packed with Standing Room Only!

“THE PATCHWORK GIRL OF OZ”



*Played to over 65,000 people at the Strand Theatre in New York
in one week. Crowded every minute—Standing room three to
four rows deep—Matinees and Nights! Booked by Paramount!*

“The production will prove of value to the exhibitor, because it has the merit
of originality and because some parts of the film will send the average audience
into roars of laughter.”—W. Stephen Bush in “Moving Picture World.”

ANOTHER WONDERFUL FEATURE

HIS MAJESTY

The Scarecrow of OZ

Just completed. The most wonderful Photography—the cleverest tricks—the
most interesting story—ever put in motion pictures.

**OZ Pictures Have Opened A New Field
to the Theatre Manager Which Enables
Him to Crowd His Houses At All Times.**

Coming: — “THE MAGIC CLOAK OF OZ”
“THE LAST EGYPTIAN”

THE OZ FILM MANUFACTURING CO.

Studio and Laboratories:
SANTA MONICA BLVD., Gower to Lodi Sts., Los Angeles, Cal.



Cosmofotofilm Co

"WHERE THE REAL FEATURES COME FROM"

Presents

"ENGLAND EXPECTS—"

(IN TWO PARTS)

Copyright 1914

Based on Nelson's Immortal Message at the Battle of Trafalgar

"England expects that every man this day will do his duty"

WRITTEN AND PRODUCED BY GEORGE LOANE TUCKER

FILMED BY THE LONDON FILM COMPANY

FEATURING

CHARLES ROCK, GEORGE BELLAMY AND JANE GAIL

To be shown shortly at the "Million Dollar" STRAND Theatre, New York.

Moe Marks, of the "STRAND," says: "'England Expects—' is a grand subject—one that will appeal to EVERYONE."

An Advance Press Comment

"This picture contains the cleverest Child Acting we have ever seen."—Motion Picture News.



London Film Co.
(Trade Mark)



London Film Co.
(Trade Mark)

"The father in his office reads the call to arms"

This film has been approved unconditionally by the National Board of Censorship

STATE RIGHTS NOW SELLING!

Address

Cosmofotofilm Co

WORLD'S TOWER BUILDING, 110-112 W. 40TH ST., NEW YORK

Be sure to mention "THE MOTION PICTURE NEWS" when writing to advertisers.

THE ALCO FILM CORPORATION

Proves Its Former Assertions by Announcing

The POSITIVE RELEASE DATES of

A List of STARS and PHOTO PLAYS

That is a REVELATION in MOTION PICTURES

Now Exhibiting the Stage's Greatest Dramatic Star

MISS ETHEL BARRYMORE IN THE NIGHTINGALE

A Five-Part Photo Play by Augustus Thomas

The Eminent Irish Character Actor

ANDREW MACK IN THE RAGGED EARL

Release Date October 12th

A REAL FEATURE

THE POPULAR PLAYS & PLAYERS CO.

Presents

The Powerful Dramatic Actor

JACOB P. ADLER

THE TRUE RURAL CLASSIC

ALL STAR FEATURE CORPORATION

Presents

SHORE ACRES

with

SHORE ACRES

The Powerful Dramatic Actor
JACOB P. ADLER

in
James A. Herne's Masterpiece
To Be Released October 26th

Money Magnets
Dec. 28th. Lillian Russell in Wildfire.
Jan. 4th. Beatriz Michelena in Mignon.

**WITH A SEQUENCE OF ASTONISHING
LEGITIMATE SUCCESSES**
Deep Purple. Alias Jimmy Valentine.
The Renegade. Salvation Nell.
York State Folks. The Price She Paid.

and
William H. Crane in David Harum.

The Romantic and Adventurous Story of
MICHAEL STROGOFF
To Be Released October 19th

A Veritable List of Stars in Plays That Are Money Magnets
Nov. 2nd. Beatriz Michelena in Salomy Jane.
" 9th. Thomas Jefferson in Rip Van Winkle.

" 16th. Digby Bell in the Education of Mr. Pipp.
" 23rd. B. A. Rolfe's Production—Satan Sanderson.
" 30th. Beatriz Michelena and Blanche Chapman
in Mrs. Wiggs of the Cabbage Patch.
Dec. 7th. Master Gerald Royston in Little Lord
Fauntleroy.

" 14th. William Faversham in The World.
" 21st. Mrs. Leslie Carter in The Heart of Maryland.

Exhibitors!! Secure Bookings Now From our Nearest Exchange

- ALCO FILM CORP. OF NEW ENGLAND, 162 Tremont Street, Boston, Mass.
FOR Maine, New Hampshire, Vermont, Rhode Island, Massachusetts, Connecticut.
- ALCO FILM EXCHANGE, 1331 Vine Street, Philadelphia, Pa.
FOR Southern New Jersey, Eastern Pennsylvania.
- ALCO FILM SERVICE, 607 Broad Street, Newark, N. J.
FOR Northern New Jersey.
- ALCO FILM SERVICE, 27 W. Park Street, Butte, Mont.
FOR Washington, Idaho, Montana, Oregon.
- NEW YORK ALCO FILM EXCHANGE, 218 West 42nd Street, New York City, N. Y.
FOR State of New York.
- ALCO FILM SERVICE, 212 Fourth Avenue, Pittsburgh, Pa.
FOR Western Pennsylvania, Ohio, Kentucky, West Virginia.
- ALCO FILM SERVICE OF MISSOURI, New Grand Central Theatre, Grand and Lucas Aves., St. Louis, Mo.
FOR Missouri, Kansas, Iowa, Nebraska.
- ALCO FILM SERVICE, 911 Trent Avenue, Spokane, Wash.
FOR Washington, Idaho, Montana, Oregon.
- ALCO FILM SERVICE, 327 St. Paul Street, Baltimore, Md.
FOR Delaware, Maryland, District of Columbia, Virginia.
- ALCO FILM SERVICE, 512 Mallers Bldg., 5 So. Wabash Avenue, Chicago, Ill.
FOR Illinois, Indiana.
- ALCO FILM SERVICE, Temple Court Bldg., Minneapolis, Minn.
FOR Wisconsin, Minnesota, North and South Dakota.
- ALCO FILM SERVICE, 1214 Third Avenue, Seattle, Wash.
FOR Washington, Idaho, Montana, Oregon.
- ALCO FILM SERVICE, 710 Northwestern Bank Bldg., Portland, Ore.
FOR Washington, Idaho, Montana, Oregon.
- ALCO FILM SERVICE (Sol Lesser), 234 Eddy Street, San Francisco, Cal.
FOR California, Nevada, Arizona.
- ALCO FILM SERVICE, 514 West 8th Street, Los Angeles, Cal.

**ATSCO RADIUM GOLD FIBRE SCREENS BETTER
MAKE THE BEST PICTURES**

THE ALCO FILM CORPORATION
ALCO BUILDING 218 West 42nd St., NEW YORK



The inimitable Dot Farley in the great comedy-drama
FALSE PRIDE HAS A FALL

Three thousand feet of smiles and tears and romance. A frolicsome country girl goes to a finishing school, with mirthful results. She gets hazed—nearly drowned—rescued—married. And just when she's puffed up with pride she gets a jolt that brings about a delightful climax.

The most enjoyable comedy-drama ever produced, with a tremendous amount of action crowded into a trio of reels. Write for information about this big feature. There are 42 Warner's exchanges located in all parts of the United States and Canada. Address the one nearest you.

WARNER'S FEATURES, Inc., New York

FEATURE and COMEDY PROGRAM

Big attractions released weekly through Warner's Features, Inc. From the list below pick out your nearest Warner's Exchange and write for information.

Atlanta, Ga.	Edmonton, Can.	Philadelphia, Pa.
Baltimore, Md.	El Paso, Texas	Pittsburgh, Pa.
Boston, Mass.	Indianapolis, Ind.	Portland, Me.
Buffalo, N. Y.	Kansas City, Mo.	Portland, Ore.
Calgary, Can.	London, Eng.	San Antonio, Texas
Cleveland, Ohio	Los Angeles, Cal.	San Francisco, Cal.
Charlotte, N. C.	Louisville, Ky.	St. Louis, Mo.
Chicago, Ill.	Minneapolis, Minn.	Seattle, Wash.
Charleston, W. Va.	Montreal, Can.	Spokane, Wash.
Cincinnati, Ohio	Nashville, Tenn.	Syracuse, N. Y.
Dallas, Texas	Newark, N. J.	Toronto, Can.
Denver, Colo.	New Orleans, La.	Washington, D. C.
Des Moines, Iowa	New York City	Wilkes Barre, Pa.
Detroit, Mich.	Omaha, Neb.	Winnipeg, Can.

SPECIAL

The Adventures of Kitty Cobb

James Montgomery Flagg's masterpiece in a great four-part feature. The hit of the year. Write for booking.

WARNER'S FEATURES, Inc., New York

Announcement—

THIS announces the coming of another great Thanhouser serial story to follow *The Million Dollar Mystery* in the leading theatres and in 500 prominent newspapers. Watch for

ZUDORA

Thanhouser's Greatest Photoplay

This new production will be a revelation of Hindu mysticism and science. It will portray mechanical effects never before seen at the movies. It is alive with thrills SENSATIONS. Zudora is the masterful creation of Daniel Carson Goodman—famous author, philosopher, scientist and originator of the modern school of realism in motion pictures.

It has been novelized by Harold McGrath for the newspapers. The story will be complete in 20 episodes. A two-reel episode will be released each week starting November 23.

Write for Booking Information

Exhibitors who profited by the overwhelming success of *The Million Dollar Mystery* will be quick to realize the value of this new attraction—ZUDORA. Applications are now being received. Rush yours in at once if you wish to secure this headliner. Write to



THANHOUSER SYNDICATE
CORPORATION

71 W. 23rd Street, New York City

Produced by

THANHOUSER FILM CORPORATION
New Rochelle, N. Y.

Producers of *The Million Dollar Mystery*



"When You See It
In 'The News'
It's NEWS"

Motion Picture News

"The Exhibitors'
Medium of
Communication"

HAS THE QUALITY CIRCULATION OF THE TRADE

Tel. 7650 Bryant

NO. 220 WEST FORTY-SECOND STREET

New York City

Volume X

OCTOBER 17, 1914.

Number 15

Have You \$100 to Throw Away?

THE War Tax Bill, through which it is proposed to place a tax of \$100 per annum on every motion picture theatre in the United States in cities of 15,000 population and over, is now in the hands of the Finance Committee of the United States Senate.

If amended, and passed by the Senate as amended, the bill will be referred back to the House for final passage.

It is not too late for you to act.

You means every exhibitor affected by this measure. And it is highly necessary for you to act, *unless you have \$100 to throw away.*

* * *

IT is too late to do away with the tax altogether. But, thanks to the activity of President Pearce and others, there is right now a good chance to have the tax graduated and reduced so that you need only bear a fraction of the proposed amount.

This issue of THE MOTION PICTURE NEWS tells how the exhibitors all over the country feel about the tax and what they are doing.

Read it over.

* * *

PRESIDENT PEARCE and Vice-President Brylawski of the M. P. E. L. of America—the organization that so greatly deserves, if it does not have your year-around support—have side-tracked their private interests and are working hard at Washington—in your behalf.

Local leaders are supporting their efforts by sending telegrams and letters to senators and congressmen.

* * *

BUT you will note that this help goes forth from only a few of the larger cities, through leaders who are but a handful as compared with the exhibitor body in this country.

Mr. Brylawski says: "*It will be necessary for every exhibitor to do his share.*"

And he adds: "If the exhibitors all over the country will communicate directly with the senators from their states—I feel assured we will be able to secure a very material reduction in the proposed tax."

THE MOTION PICTURE NEWS earnestly endorses this appeal and makes the suggestion that these communications be made direct to the Congressman or Senator from your district.

For your convenience and *that you may write at once*, we suggest the following form letter:

Hon. _____, House of Representatives (or Senate),
Washington, D. C.

Dear Sir:—As an exhibitor of motion pictures, I am forced to protest vigorously against the proposed war tax of \$100 on motion picture theatres (in towns of 15,000 population and over) and beg to submit the following facts for the consideration of your committee.

It is unjust to burden with an equal tax the motion picture theatre which charges but five or ten cents admission and the regular theatre with admission prices of fifty cents to two dollars.

It is unjust to tax equally and indiscriminately the theatre which seats under three hundred and the one with a seating capacity of over one thousand.

Furthermore, I contend that the motion picture theatre is largely a poor man's place of recreation and education, and that as such it is more a necessity than a luxury; and that the exhibitor feels the burden of these war times more than the retail businesses you do not propose to tax. These businesses, moreover, could raise their prices if taxed, whereas the exhibitor can not.

The result of this sweeping tax will inevitably be the closing out of many small picture theatres throughout the country.

I believe that in all justice this tax should be graduated, according to the seating capacities of the motion picture theatres affected and that the limit tax should be based upon the gross business of the picture theatre as compared with the regular theatre.

Respectfully yours,

* * *

WRITE this or a similar letter *today* and send it by registered mail.

A second suggestion is made—this in view of the weight borne by popular opinion upon the representatives at Washington.

Make the following slide and run it for a week in your theatre:

Congress proposes to place a war tax of \$100 upon all the picture theatres in this city. This may affect you.

Follow this with another slide:

The house will be lighted for three minutes for you to read over the slip handed you at the door. Sign this and hand it back to the usher.

* * *

THEN have the following letter printed and distributed to your patrons as they enter:

Chairman Finance Committee, U. S. Senate,
Washington, D. C.

Dear Sir:—I am informed that Congress proposes to lay a war tax of \$100 per annum on the picture theatres of this city.

joyed by those who can better afford to bear this burden. I do not see why the picture theatre with its low admission price should be included in this class.

Respectfully yours,

After these slips have been signed, collect them in a bundle and send them *by registered mail* to the Chairman of the Finance Committee, United States Senate, Washington, D. C., or your Congressman.

This is merely a suggestion which you may, or may not regard favorably, *but at least you can write the letter.*

* * *

REMEMBER that the outcome—the question of whether you will pay \$100 or possibly \$10—depends upon this simple matter. Do it, and do it *now!* An organization such as the Motion Picture Ex-

LEAGUE WINS FIRST POINT IN FIGHT TO MODIFY WAR TAX MEASURE

The latest news from Washington is that the \$100 tax on motion picture theatres, irrespective of size or seating capacity, will be abandoned, and in its place a graduated tax substituted.

The following extract from a letter from Fulton Brylawski, Vice-president of the Motion Picture Exhibitors' League, speaks for itself:

"It gives me great pleasure to be able to inform you that on Saturday last the Senate Finance Committee accepted the scale proposed by me in lieu of the flat tax proposed in the House Bill, which scale is as follows:

Theatres seating less than 300, shall pay \$25.
Theatres seating more than 300 and less than 600, shall pay \$50.
Theatres seating more than 600 and less than \$1,000, shall pay \$75.
Theatres seating over 1,000, shall pay \$100.

"I BELIEVE THAT THIS NEW SCALE WILL SAVE THE MOTION PICTURE EXHIBITORS OF THIS COUNTRY NEARLY ONE MILLION DOLLARS.

"Very truly yours, (Signed) FULTON BRYLAWSKI."

This does not mean it is "all over." The Senate and the House have still to ratify this amendment.

Send in your protests to Congress just the same.

Keep on fighting until you are sure the victory is won.

Don't relax your efforts until the bill is passed and signed in the form you wish.

ACT NOW!

SEND IN YOUR PROTESTS TODAY!

DO IT AT ONCE!

As a regular patron of motion pictures, I desire to protest against this action in the belief that it will result in the closing of many theatres and in the raising of prices in others.

The motion picture theatre has become necessary to me and the members of my family as a place of recreation and education.

It was my understanding that this tax was to be levied upon luxuries. There are plenty of such en-

hibitors' League of America would be if it had your membership could without a doubt have solved this problem for you.

As it stands, the officers are doing everything in their power, *but they cannot be successful without your help.*

ACT AT ONCE!

WILLIAM A. JOHNSTON.

BUFFALO FEATURE FIRM RE-INCORPORATES

Special to THE MOTION PICTURE NEWS

Buffalo, Oct. 7.

THE Buffalo Feature Film Corporation was re-incorporated last week and the capital increased to \$100,000.

The following officers were elected: President and general manager, George H. Verbeck, who has for over twenty years taken an active interest in all kinds of theatrical business; secretary and treasurer, Wilbur B. Grandison, a prominent local attorney; and F. M. Zimmerman, road man and booker, who has been with the company since its initial organization, some time ago.

Other directors are Joseph J. Raymond, general manager of the Gordon theatre in Rochester; and Clinton T. Horton, who has been nominated for Congress from this district. There is also a leading film man in New York City, who is a silent member of the board of directors.

SURRENDER NEWARK LICENSES

Special to THE MOTION PICTURE NEWS

Newark, N. J., Oct. 7.

TWO withdrawals from the motion picture business were announced at a meeting of the East Orange City Council.

The North Jersey Amusement Company, which had the license for the Lyceum at 506 and 508 Main street, for the past year, sent a letter saying the company would not apply for a renewal of its license, and the First Ward Amusement Company withdrew an application which it had pending before the council.

A deposit of \$100 was ordered returned to the latter concern.

In the case of the Lyceum, however, the Masonic Realty Company, owner of the building, applied for and was granted a license for that location.

Motion Picture Theatre Tax Crisis Reveals Value of a Strong National Organization

PRESIDENT MARION S. PEARCE has been the busiest man in Washington since the first hint that a tax on Motion Picture Theatres was to be included in the bill, now under discussion in the Capitol. Day and night he has been working, interviewing everybody whose opinions are of value to the League, protesting in the strongest terms against the provisions of the bill, and laboring incessantly that the bill, when finally passed, might be of such a nature as would prove least objectionable to exhibitors everywhere.

"In the first place, the League was assured," said Mr. Pearce the other day, "that the bill, which was in course of preparation by the Ways and Means Committee of the House of Representatives, would include no tax whatever on motion picture theaters. Hence it was a complete surprise to learn, when the bill was reported out of the committee, that each motion picture theatre in the country was to be burdened with a tax of \$100, regardless of size, capacity or anything else.

No Hearing Before the House

"To make the matter harder to get at, a special provision had even then been agreed on, that this bill could not be amended on the floor of the House, and, furthermore, no hearing, either public or private, would be permitted.

"Confronted with this condition, the obvious thing to do was to pick the bill up at the first available point, i. e., in the United States Senate, and bring all possible pressure to bear on the Finance Committee to which the measure had been referred."

Without the very limit of powerful effort that was brought to bear, even in an interview, would have proven entirely out of the question with most of the men, and to this end, President Pearce has been untiring in his efforts, working day and night, and losing no opportunity to say a word here, and plant a fact there, to bring about the desired result.

Committee Will Agree to Amendment

After interviewing the chairman and members of the Committee of Finance, they immediately saw the justice of the protest to the original bill, and the equitable features of the amendment, and unhesitatingly said so. While it is sure that the tax cannot be removed from motion picture theatres entirely (which was the first effort made), at the same time it is equally certain that it will not pass in its present form, but will include, when reported out of the Committee, embodying as a component part, a graduated scale which is fair and just to exhibitors both large and small.

President Pearce wants to impress on every exhibitor in the United States the fact that both members of the House of Representatives and United States Senators have come to realize and appreciate, when they apparently did not heretofore, what a tremendous power and influence for good lies in the exhibitors of the country.

They have had it proven to them conclusively, through the telegrams and letters sent them, that the League is a mighty factor for good; and they have so expressed themselves to President Pearce repeatedly during the past few days.

"And it only takes just such an occasion as this," Mr. Pearce went on, "to bring home to every individual exhibitor that *HE IS A MEMBER OF AN ORGANIZATION* big enough and strong enough to seek *JUSTICE AND EQUITABLE CONSIDERATION*—and better than that—*TO GET IT BECAUSE HE DESERVES IT!* With such strength as this has brought out from the League, and such splendid results

President Pearce working day and night to obtain a fair measure from Senate—Brylawski active in campaign of protest at the Capitol—Rochester exhibitors wire protests; Illinois managers follow suit—Maryland asks for just tax rate—Ruin of small houses sure, if bill goes through as passed by House, exhibitors declare—Value of national organization emphasized.

secured through it, it ought to convince every exhibitor that the good effects of co-operation are too big to be measured—the benefits too great to be calculated, if each man will stand by the League with all his might and give it the best efforts he has in him."

Thanks Exhibitors for Their Support

President Pearce wants especially to thank every member of the League for the splendid way they responded to the request for telegrams and letters to the Senators and members of Congress on this War Tax measure.

The good effect of these made it easier to accomplish what has been done, and President Pearce wants every exhibitor in the country to realize that *not for an hour will he leave Washington*, nor lose sight of the issue at hand.

He has sidetracked everything else, and is watching the progress of the bill and will continue to do so right up to the moment it becomes a law, with the best interests of the League solely in mind.

Washington Exhibitors Ask Reasonable Tax; Brylawski Appeals to Senate Committee

Special to THE MOTION PICTURE NEWS

Washington, D. C., October 7.

ACCORDING to the looks of matters in motion picture circles here, there is to be a fight in Congress relative to the proposed tax to be placed on motion picture theatres, but this fight will be based on a reasonable tax and not with the idea of shrinking from assisting in the national revenue. Fulton Brylawski, as vice-president of the Motion Picture Exhibitors' League of America, wrote a letter to every member of the United States Senate, which is here given:

The Motion Picture Exhibitors' League of the District of Columbia

Office of the Secretary, Jenifer Bldg., Washington, D. C.

"Dear Sir: The Bill, H. R. 18891, 'To increase the Internal Revenue and for Other Purposes,' provides, among other things, in the sixth section thereof that:

"Proprietors of theatres, museums and concert halls in cities having more than fifteen thousand population as shown by the last preceding United States census, shall pay \$100. Every edifice used for the purpose of dramatic or operatic or other representations, plays or performances, for admission to which entrance money is received, not including halls rented or used occasionally for concerts or theatrical representations, shall be regarded as a theatre.

"As the National Vice-president of the Motion Picture Exhibitors' League of America, which includes in its membership thousands of motion picture theatres in all sections of the United States, and as the Secretary of the Motion Picture Exhibitors' League of the District of Columbia, I respectfully beg to submit the following to your consideration:

"The wording of the measure in its present form does not differentiate between theatres, excepting that theatres in towns of less than fifteen thousand inhabitants are not liable to this special tax. In a town of less than fifteen thousand inhabitants there are in many instances only several theatres, each of which may do a thriving business.

"In this city, for example, there are about ninety moving picture theatres, seating anywhere from one hundred and fifty to a thousand or more persons, and in addition thereto there

are ten large theatres playing dramatic, operatic, vaudeville and burlesque attractions, so that there is, in this city, one theatre to every thirty-five hundred inhabitants.

Smaller Theatres Face Extinction

"The larger theatres with their greater seating capacity and the higher prices charged could, without feeling it a burden, easily pay the one hundred dollar tax intended to be levied by this proposed legislation, but the small theatre—the little moving picture house with only a few hundred seats and where the admission charge is only five or ten cents—would not only feel such a tax burdensome in the extreme, but in a great number of instances *would be compelled to go out of business.*

"Judged by the popular idea of the enormous profits in the motion picture business, this statement may seem an exaggeration, but during the past year there were many moving picture theatres in this city that were compelled to go out of business because of their inability to cope with the larger theatres.

"During the month of November every theatre in this city, large or small, must pay to the District of Columbia one hundred and five dollars for a license to operate during the coming year. Many of them will be hard pressed to realize this amount and if compelled to pay an additional hundred dollars towards the Internal Revenue, I can state with great positiveness and certainty that a large number will be forced out of existence simply on this account.

"It is not the purpose of this communication to endeavor to shirk the responsibility of defraying a part of this country's revenue, but simply to suggest a far more equitable manner of levying same, and as an example a sliding scale, like the following, would answer this purpose:

Theatres seating less than 300 might be taxed.....	\$ 25
Theatres seating more than 300 and not exceeding 500.	50
Theatres seating more than 500 and not exceeding 1,000	75
Theatres seating more than 1,000.....	100

"I feel sure that if you will give the proper consideration to this letter you will, as a fair-minded man, see the force and equitableness of the argument herein advanced.

"Respectfully,
(Signed) "FULTON BRYLAWSKI,"

Interviewing Mr. Brylawski on the progress of this matter, he made the following interesting statements:

Senators Recognize Unfairness of Tax

"To date I have received more than fifty answers to the ninety-nine letters written to the members of the United States Senate, many of whom have stated that they recognize the unfairness of the proposed legislation and will do all in their power to have the law modified, to meet the views of the motion picture exhibitors.

"Amendments have been prepared covering this section and they will be introduced at the proper time by prominent Democratic senators. President Pearce of the National League has been in Washington daily interviewing various senators and has been assured the active assistance of Maryland senators.

"Messrs. Varner, Sams and Lambert, representing the Piedmont Amusement Company of North Carolina, with headquarters at Winston-Salem, called at my office recently. They came for the purpose of advancing arguments through Senator Simmons of North Carolina, chairman of the Committee on Finance, which has the consideration of the proposed bill.

"They, with President Pearce and myself, drew up a set of specific arguments against the proposed measure insofar as it affects the motion picture business. These will be presented in person.

"President Pearce has written and wired to the various state presidents and to the national vice-presidents of the Motion Picture Exhibitors' League, asking these members to wire their senators their views on the pending legislation.

Exhibitors Must Do Their Share

"I believe this matter to be extremely urgent," went on Mr. Brylawski, "and if the exhibitors all over the country will communicate immediately with the senators from their states protesting against the unfairness of compelling the motion

picture houses to stand the same tax as the large theatres and circuses, I feel assured we will be able to secure a very material reduction in the proposed tax.

"However, in order to effect this, *it will be necessary for every exhibitor to do his share.* I am giving this matter very close attention and I hope to be able to present arguments against the bill, from the standpoint of the motion picture man, before the committee in person."

It must be understood that Mr. Brylawski is not only an officer of the national and local motion picture leagues, but he is a lawyer of recognized ability in Washington. He has amicably settled many questions arising among the exhibitors and is well known in Congress and in court circles.

THEODORE FRANKLIN.

Des Moines Exhibitors Kick, But Refuse to Act Against War Tax

Special to THE MOTION PICTURE NEWS

Des Moines, Ia., Oct. 6.

DES MOINES exhibitors will make no effort to head off the war tax which Congress proposes to impose on theatres. The exhibitors and theatrical heads will look to their national organizations for relief from what they regard as an obnoxious law.

Elbert & Getchell, the theatrical managers of Des Moines, own the Unique, one of the leading film houses. They also lease the four leading theatres, the Empress, the Majestic, the Princess and the Berchel. They use films in all of them. B. F. Elbert said regarding the proposed tax:

"It is a matter that we shall leave for solution to the National Association of Theatrical Producing Managers. I do not believe that we could accomplish much here. As a theatrical proposition it will be an increased burden on houses that are barely able to get along.

Do Not Believe Government Needs Money

"We would not object to our share of the tax if we believed the government needed the money and was practicing economy itself. The Government, however, has made no effort to be economical. They are going to spend \$100,000,000 for rivers and harbors just the same, if Congress can get away with the bill. In other directions the Government is equally as extravagant and unreasonable.

"They made a partial failure of the income tax bill as a revenue collector. Now they are going to dig the revenue out of us fellows, the bankers and other business enterprises that they can get easily. They can get at us without working very hard. It requires no effort to put an extra tax on beer, or to tax the other industries of the country. The Government keeps on spending money just the same.

"The war has decreased the revenues, but you don't see any bills up in Congress for the purpose of reducing expenses. That is what makes me sore and that is what I kick against. It will be a hardship not only on the picture houses, but on the theatres also. In Des Moines the business is overdone the same as it is in many other places. There are only a few of the picture houses in the city that are actually making money and the theatres are making still less. We are making as much money as any of them, but the tax is going to impose a hardship. We tried during the summer to charge ten cents and put up a better class of stuff in the picture line, but the combine was in effect one day and one of the houses broke it by going back to five cents."

Leave It to the State Organization

Abram H. Blank, of the Garden theatre, one of the finest picture houses in the state and the only regular ten cent house in the city, said:

"Nothing is being done by the exhibitors in Des Moines. I do not believe anything will be done. The association is not very strong here and does not hang together very well. We will leave it to the state and national organizations.

"The war tax is not fair. It will hurt the smaller houses. Moving picture theatres are as much a necessity for the working people as the sugar they put in their coffee. I do not

object to a tax, but the figures proposed by the Government are too high. They are exorbitant. If a war tax has to be fastened on something by the Government we will have to pay it, but we do not want to pay more than our just proportion."

Theatrical men generally declare that the extravagance and prodigality of the Government at this time amounts almost to profligacy. There is regarded to be no consistency between the imposition of an indiscriminate war tax and the expenditures of the Government.

C. C. WENTZLER.

Rochester Exhibitors Protest to Congress

Rochester, N. Y., Oct. 7.

PRESIDENT A. N. WOLFF, of the New York State branch of the Motion Picture Exhibitors' League of America, has been a busy man ever since it became known that Congress contemplated taxing all theatres in towns of more than 15,000 inhabitants \$100 a year, as a part of the war tax to meet the deficiency in government revenues.

Immediately upon receiving word to that effect from President Pearce, of Baltimore, he wired the protest of the Rochester exhibitors to Congressmen H. G. Danforth and Thomas B. Dunn at Washington.

This protest voiced the feeling of the forty odd exhibitors in Rochester, who would be compelled to pay the tax.

At the same time President Wolff drafted a circular letter to be sent to each of the exhibitors in New York State, requesting them to wire their representatives in Congress, protesting against the proposed tax.

Form of Tax Objectionable

Not only the tax itself, but the form of it, is objectionable to the local exhibitors. They do not believe, in the first place, that the poor man's pleasure should be taxed, and, in the second place, they do not believe that the tax has been levied in a proper manner.

"As I understand it," said Mr. Wolff, "this tax was supposed to be placed on luxuries. No one will say that a moving picture entertainment, at five or ten cents, is a luxury. It is about the only pleasure that the poor man and his family may enjoy. Taxing that is taxing the poor man's sole means of recreation, one which has become marvelously popular in a very few years.

"There is no telling when such a tax would be removed, if once imposed.

"The tax is not properly spread, in the next place. It should be based on the seating capacity of a theatre, or upon the net income, or gross receipts. Theatres of small seating capacity, with the opportunity to make but small profits, should not be taxed as much as the larger theatres.

No Distinction Made

"The proposed law, as I understand it, makes no difference between picture theatres and other kinds. Theatres which charge as high as \$2 a seat are taxed no more than those which charge but five cents a seat. This is obviously most unfair.

"Every exhibitor should interest himself in this matter to the extent of making his views known to his representative in Congress."

ARTHUR R. TUCKER.

A Fairly Proportioned Tax Rate Is All That Maryland Exhibitors Demand

Special to THE MOTION PICTURE NEWS

Baltimore, Oct. 7.

THE motion picture men of Maryland take the stand that the war tax proposed by the United States Government of \$100 for each theatre is out of all proportion. The feeling among the exhibitors in Baltimore, particularly, is that they should not be assessed at the same rate as legitimate theatres. The latter can accommodate at each performance four or five times as many patrons, at the same time receiving so much higher admissions.

A meeting of the Maryland league of the Motion Picture Exhibitors' League of America was held recently, at which the war tax was discussed.

Alexander Anderson, C. F. Habighurst, President Marion S. Pearce, J. Howard Bennett, Joseph Brodie and Guy L. Wonders took a prominent part in the discussion. The feeling brought out was that the motion picture men of Maryland wanted to pay their share of the war tax and were perfectly willing to pay a fair proportion.

\$10 a Theatre a Fair Sum

It was a feeling of the meeting that \$10 for every motion picture house, particularly the smaller motion picture houses, would be an adequate sum.

The secretary was instructed to communicate with the Maryland representatives in both houses of Congress, and make plain the feeling of the motion picture exhibitors on this subject.

Another meeting will be held just as soon as a communication has been received from the Maryland delegation in Congress.

Another matter which was brought up at the meeting was the question of country store and other freak specialties conducted in some of the Baltimore picture houses. All of the film men in this city attended the meeting at a special invitation from the president.

The film men were asked to co-operate with the exhibitors in eliminating this objectionable feature. They pledged themselves to do so and even suggested that they may go so far as to refuse to rent films to exhibitors who persisted in conducting catch-penny features in connection with motion picture shows.

The members of the league feel very optimistic now of the elimination of the country store and other features from the exhibitors' resources.

Postpone Action on Higher Prices

Following a suggestion made several months ago to increase the general price of admission to motion picture houses from five to ten cents was brought up. While there are several ten-cent houses in Baltimore, the great majority have five-cent admissions.

While a large number of the exhibitors were in favor of increasing the admission, no definite action was taken, as it was felt that the increase in price should be general throughout the entire city, and, until perfect unity is established on the subject, the increased admission price should be left in the hands of the individual exhibitors and not made a rule of the league.

A. F. GILLASPEY.

HAVE YOU \$100 TO THROW AWAY?

Can you afford to pay \$100 a year more to run your theatre than you are paying now?

IF NOT

WHY DON'T YOU LET THE FINANCE COMMITTEE OF THE UNITED STATES SENATE KNOW ABOUT IT?

Other exhibitors are taking measures to protect themselves

WHY DON'T YOU?

Appeal to the fairness of the Government to-day! It will cost you little if you do

IT MAY COST YOU A GREAT DEAL IF YOU DON'T

Illinois Exhibitors Wire Protests to Senators and Congressmen

Special to THE MOTION PICTURE NEWS

Springfield, Ill., October 6.

OFFICIALS of Illinois State Branch No. 2, Motion Picture Exhibitors' League of America, have taken quick action in protest to the war tax measure now before Congress, which provides for a tax of \$100 on every motion picture theatre in cities over 15,000 population.

G. M. Luttrell, of Jacksonville, president of the state branch, has already wired the Illinois senators to the following effect:

"Officially representing practically every motion picture theatre in Illinois, we strongly protest against the original motion picture war tax bill as passed. But approve amended scale of \$10 up to one thousand seating capacity, and \$50 over one thousand seating capacity."

Wires Sent to Members of Congress

Besides this, President Luttrell has written practically every exhibitor in the state urging him to protest to the state's senators.

W. W. Watts, treasurer of the state branch and owner of the Vaudette theatre here, said in an interview:

"I have wired a protest to Senator L. Y. Sherman and will write Congressman Graham regarding the proposed tax. Every exhibitor in Springfield will file a protest, I am sure. I believe the national officers will soon have a committee in Washington to make a protest.

"This is one of the times when *the need of a good, strong organization is felt*. In this matter, motion picture exhibitors will have to act quickly, and I believe it will go a long way toward bringing to every exhibitor the realization that *he must do his part in aiding in the formation of a strong national organization*."

Two plans for a campaign against the proposed war tax of \$100 on motion picture theatres were offered by A. F. Kunz, proprietor of the Grand theatre.

"The exhibitors have no real organization with which to fight the proposed tax," Mr. Kunz said, "but there is a way of getting action quickly, and I believe nearly every exhibitor would join in. I'd suggest that THE MOTION PICTURE NEWS start a fund with which to hire an attorney to present the motion picture exhibitors' side to Congress. If every exhibitor would send in, say, \$2 a great fund would be quickly available and action could be gotten right away.

Use Slides in Theatres as Protest

"Another thing is to start a campaign against the proposed tax by using slides in every picture theatre protesting. That would give the bill quick publicity, and I'm sure would bring results.

"It seems unfair to tax the picture theatre, which already pays a big license to operate, and allow other lines of business to escape the tax."

"Just why the motion picture theatres should be taxed \$100 under the proposed war tax bill and other lines of business not taxed, is more than I can understand," Benjamin Rovin, manager of the Amuse-U theatre, said. "We already are paying a license to operate and now there comes this additional tax. The exhibitors certainly will fight the proposed law."

Needs Strong Organization to Act

"My understanding is that motion picture houses are not classed as theatres, but as amusement places, and that being in that class, will be taxed only \$10 under the proposed war tax bill," Harry Loper, manager of the Lyric theatre, said. "One thing is certain: if motion picture theatres are taxed \$100 under the war tax measure there will be no more five-cent tickets sold at this theatre.

"As individuals we exhibitors are unable to do anything, and it will take a strong organization to act in this matter to any effect."

C. C. CHEADLE.

War Tax a Strong Argument for National Organization

Special to THE MOTION PICTURE NEWS

Harrisburg, Pa., Oct. 7.

"THE chief injustice in the proposal to impose a war tax of \$100 upon theatres," said C. Floyd Hopkins, manager of the Colonial, Third and Market streets, and of two other big Harrisburg theatres which, unlike the Colonial, are not essentially motion picture houses, "is that it hits the kind of business that is the first to suffer when times become bad. Everybody knows that when general business depression occurs the first direction in which people begin to economize is in that of cutting down on forms of entertainment.

"Thus we see Congress proposing to place the heaviest burden of hard times on the business that suffers most from the depression."

Tax Best Argument for Organization

Peter Magaro, who will manage a new theatre that is being built on the site of the old Star, 410 Market street, and manager of a large theatre in Carlisle, Pa., regards the war tax on theatres as entirely unfair, but doesn't see how anything can be done now to prevent its being imposed. "If the motion picture men had only been better organized," said Mr. Magaro, "and been able to employ a man in Washington to keep them acquainted with what was going on in the matter of preparation of legislation affecting the business, the individual exhibitors and local organizations might have been able to exert an influence over their home congressmen in time to prevent the injustice now being done. The war tax is a good argument for better organization in the future."

"Means Ruin for Small Theatres"—Klinger

"As soon as I heard of the war tax plan I wrote to the congressman from this district and urged him to oppose the unjust measure," said C. D. Klinger, manager of the Palace, 333 Market street. "I pointed out to him that it simply means ruin for a number of the small theatre owners.

"If there is to be a tax at all on theatres, it should be apportioned according to the amount of business done or the number of seats in a house. It is manifestly ridiculous to tax small houses with 300 or 400 seats, many of which give performances only twice a week, the same fixed amount that is imposed on houses that seat 1,500 or 2,000 persons and have performances afternoon and evening every day in the week."

V. H. BERGHAUS, JR.

Chattanooga Exhibitor Denounces Proposed War Tax on Theatres

Special to THE MOTION PICTURE NEWS

Chattanooga, Tenn., Oct. 6.

MANAGER MUGNIER of the Picto motion picture theatre, 729 Market street, Chattanooga, Tenn., is bitter in his denunciation of the proposed war tax on motion picture theatres. He considers the war tax proposition little short of robbery in the first degree. His opinion follows:

"I am strictly opposed to the proposed war tax on motion picture theatres. I consider it an imposition to the greatest extent. It is simply robbery in the first degree. The motion picture business is already suffering because of the European war and why impose a tax on exhibitors when they have nothing whatever to do with the war?

"The levying of a tax on a man with a staple line of goods enables him to raise his price to meet the tax. The people can do without their amusement. We've got all the expense we can meet. Why pile more upon us?"

**HAVE YOU \$100
To Throw Away?
SEE PAGE 17**

TIME IS RIPE FOR MOTION PICTURE NEWS BOARD OF TRADE, SAYS MILWAUKEE EXHIBITOR

"The proposed war tax is most unfair," says J. H. Silliman, owner and manager of the Liberty Theatre, Milwaukee, Wis. "If they must tax theatres let them tax them according to their seating capacity or their profits. Under the present plan the theatres with but a few hundred seats and getting but a nickle will have to pay the same tax as the big \$2.00-a-seat legitimate theatre. I am afraid that the tax will wipe out many of the little fellows, especially here in Milwaukee where we have a local license to pay. Now is the time for the formation of the board of trade, composed of representatives of the exchange men, producers and exhibitors such as was proposed at the time of the New York convention by the MOTION PICTURE NEWS, to fight this bill."

Texas Exhibitors Will Fight the Tax

Special to THE MOTION PICTURE NEWS

Dallas, Texas, Oct. 6.

EXHIBITORS in Dallas and all over Texas are up in arms over the proposition of taxing film theatres \$100 per year as a war tax. Already telegrams have been sent to representatives in congress and senate from various points in Texas and as much pressure is being brought to bear on these representatives as possible to get them to oppose the measure.

The general views of each man seen by a representative of THE MOTION PICTURE NEWS was that they were willing to stand their part of any tax thought necessary, but they did not believe that such a heavy tax should be imposed on their business, which they consider a legitimate business and a business which now stands as much taxation as any.

"Exhibitors Targets for Every Kind of Tax"

"It's a tax on education," was the way G. K. Jorgensen, owner of the Crystal Theatre at Dallas and owner and operator of four Crystal theatres at Galveston, expressed himself. Mr. Jorgensen is one of the pioneers in the business in Texas and has seen it grow from its small beginning to its present big dimensions.

"Naturally we consider the tax unjust," said Mr. Jorgensen, "and I for one am doing and am going to do all I can to defeat the measure. We are willing to pay our part to help take care of the operating expenses of the government, but no more.

"We exhibitors are already the targets for every kind of tax. In Galveston, for instance, each theatre is taxed a certain sum to pay a special officer for duty at his house. Of course, it is not needed and it is a species of graft, but is required by city ordinance.

"The war has affected our business as well as all other lines of business and our expenses have increased wonderfully in the last few years. We are also giving people more for the same money.

"I consider the motion picture business as a necessity instead of a luxury, as it is the amusement for the people in the poorer walks of life. It is also a great educational treat for many people and when they put an exorbitant war tax on the picture houses, they are simply taxing education."

Base Tax on Business Done

P. G. Cameron, proprietor of the Roseland at Dallas, offered a rather new idea. He believes that the tax on theatres should be based on the amount of business done, if they have to be taxed, but is against the tax at all on the grounds that it is discriminatory and is classed legislation.

"It is class legislation pure and simple, that a motion picture house should be taxed for war relief measures," said Mr. Cameron. "We should not be required to pay the tax. There is no way for us to get our money back as the set price of admission cannot be changed.

"Why the bill should have been drawn to not apply to picture houses in cities of less than 15,000 is beyond me. The houses in the smaller cities make more money than do those in the larger cities. They have less rent, do not pay as much for films and their operating expenses cannot compare with the shows in the larger places.

"If the tax has to be imposed it appears to me that it should be along the same lines as went into effect following the war with Spain. Let the government furnish us with specially designed tickets and then each house would pay according to the amount of business they did. I can see no justification for the tax at all, though as a loyal citizen I am willing to pay my legitimate share of expenses of government operation."

Finnegan for Lower Tax, If Any

"You can put me down as being opposed to the tax as proposed," said T. P. Finnegan of The Hippodrome. "I think it is an unjust proposition and cannot see why such a heavy tax should be imposed on those engaged in the moving picture business and so many other lines of business go untouched.

"I would suggest that, if a tax is necessary for film houses, it be based on seating capacity. Say let a tax of \$10 per year be levied on house of 1,000 seating capacity and \$50 per year or some other equitable amount for houses having a larger seating capacity.

"The film business is being as hard hit by the war as any other line of business and I do not believe we should tamely submit to this unfair tax." E. R. HAMBRIK.

Omaha Exhibitors Urge Loyalty to National Organization

Special to THE MOTION PICTURE NEWS

Omaha, Neb., Oct. 6.

M. M. ARONSON, manager of the Cameraphone Theatre at 1403 Douglas street, Omaha, bemoans the fact that his theatre will probably be called upon to pay a levy of \$100 to the government. He wants to know what can be done to prevent it. Mr. Aronson's theatre is doing an excellent business; it is run on a high plane and he has an enviable standing among the exhibitors.

"I have read about it," he said. "The levy will be made and we must pay it. First they levy on the saloons; then its the moving picture theatres. Why? My idea is the motion picture theatre is still looked upon more or less as an evil in the community. People living in glass houses say the moving picture theatres are immoral. Then, too, the moving picture shows are educational, and often clean and strong, but they are still classed among the unnecessaries of life.

"If the grocers were taxed, they would probably have to pay. But if Rockefeller was taxed, he would not pay. An exhibitor is not as powerful as Mr. Rockefeller. Maybe a legislative committee from the National League would prevent the levy being made, but it probably would not.

"I can not understand why an exhibitor who is perhaps losing money, perhaps playing even or perhaps making a little, should be called upon to pay for losses caused by a war in some other part of the world."

"Get Organized—Then Fight"—Roper

But there are plenty of exhibitors in Omaha who believe the unjust and unreasonable levy, as they call it, could be prevented. Their answers make an excellent response to Mr. Aronson's statement.

"Get organized, then put up the same fight other businesses would," said William Roper, manager of the Roper Theatre, Broadway and Scott streets, Council Bluffs, Ia. "Send letters,

pétitions and other remonstrances, but do not forget the power of personal contact.

"Send strong men—we have them among the exhibitors, plenty of them—to Washington and let them represent us."

"I am not exactly familiar with this levy, the purpose of it and the reason for it, but it seems unjust and unreasonable. Why should I pay \$100? Why should the other exhibitor across the street? Let us get together and ask the question of our congressmen.

"Let a lot of us get together and send a delegation to Washington. Give the National League the chance. Give it the membership and the finances. Let us adopt the plan of those organizations which have made organization a success."

I might add that Mr. Roper is one of the progressive exhibitors of this part of the country, having a fine appearing house and enjoying an excellent business. He is one of the broad minded type that believes in co-operation and everything else that will go to make the business of being an exhibitor what it should be. And, by the way, he is in business in other ways and has found by experience the value of the things he suggests.

D. Bolker, proprietor of the Parlor Theatre at Fourteenth and Douglas streets, Omaha, being a loyal member of the local and state league, said the matter should come before the local at its next meeting and every league in the country should use what influence it has to prevent the imposition of such an unjust levy.

"I have read of it in the newspapers, but I don't clearly understand it," he said. "I don't guess anybody does. The proposition should be explained at the league meeting and we should take action at once. If the railroads faced such a levy they would have their lobbying committees hard at work in no time. Such an example of combined effort should be followed by the exhibitors."

Sam Macguire, of the Rex, Twenty-fifth street and Broadway, Council Bluffs, said: "I've heard from the exhibitors about the proposed levy. I don't see any sense to it. Why don't they tax the grocery men or milkmen? I'm not doing a very big business, but I am in a city of more than 15,000 population, and I couldn't very well stand frequent levies of \$100 each. What are they trying to do, drive the exhibitors out of business?"

"Sure, there ought to be some effort made to prevent it. Combined effort would be the best, naturally. If the national league could get a powerful committee, we'd be just in it. We need some protection, and I, for one, am going to do everything in my power to get it."

GUY P. LEAVITT.

Idaho Exhibitors Declare Tax Is Unjust

Special to THE MOTION PICTURE NEWS

Boise, Idaho, Oct. 5.

EVERY one of the proprietors of the five motion picture theatres in Boise are strongly opposed to the proposed action by Congress of levying a war tax against the poor man's theatre.

They feel that the tax is unjust, is discriminating against certain classes of business and further that if the way and means committee which recommended such a tax had made more than a surface investigation of the business, the tax against the motion picture houses would not have been levied.

Under present conditions all state that *the tax cannot be met unless an advance in price is made, which they feel will affect the business materially and cut many a poor man and his family out of an evening's educational amusement together and likely send him downtown alone to some place of amusement less elevating.* Following is what they have to say on the subject:

"If a war tax is levied upon our business compelling exhibitors in cities of over 15,000 to pay \$100 each it will work such a hardship that the admission price will have to be raised.

"The public must know the cause of the raise in price and should be advised who is responsible for it, therefore every exhibitor in every moving picture show throughout the country should run an explanation upon the screen prior to the performance that the public might know the true reasons and the party responsible for such action. If the poor man is cut out of his pleasure and educational advantage which is afforded him by a ten-cent show, it is a cinch that he will vote in the interests of his amusement and education.

"When it is taken into consideration the number of people who witness the moving pictures throughout the country, the realization may come

that some mighty effective political sermons can be preached from the screen that the people will heed."

The above is the view taken of the special war tax against motion picture shows by Dave Farquhar, manager of the Isis Theatre at 111-113 North Tenth street.

He does not believe that the Ways and Means Committee which recommended the levy knows anything about the cost of operating a motion picture show, but that they have merely read about great profits made in the business, saw the glitter of the lights and the crowds and believed the business could stand the tax and recommended the levy, without taking into consideration how many dimes it takes to pay rent, hire an orchestra, ticket sellers, film service, advertising and many other expenses in connection with the business.

W. F. Bossner, proprietor of the Boz Theatre at 1008 Main street, declares that a war tax of \$100 against a theatre in a city of even 20,000 cannot be met unless the admission price is raised and feels that it is an unjust burden placed upon a small business.

(Continued on page 50.)

DO YOU BELIEVE THAT THESE EXHIBITORS ARE RIGHT?

"This crisis ought to convince every exhibitor that the good effects of co-operation are too big to be measured."—Marion S. Pearce, President, M. P. E. L. of A.

"Every exhibitor must do his share."—Fulton Brylawski, Washington, D. C.

"I do not believe we should tamely submit to this unfair tax."—T. P. Finnegan, First Vice-President, M. P. E. L. of A., Dallas, Tex.

"Every exhibitor should interest himself in this matter to the extent of making his views known to his Representative in Congress."—A. N. Wolff, President, New York State Branch No. 5, M. P. E. L. of A., Rochester, N. Y.

"This is one of the times when the need of a good, strong organization is felt. Every exhibitor . . . must do his part in aiding in the formation of a strong national organization."—W. W. Watts, Treasurer, Illinois State Branch No. 2, M. P. E. L. of A., Springfield, Ill.

"Get organized, then put up the same fight that other businesses would. Send strong men—we have them among the exhibitors, plenty of them—to Washington to represent us."—William Roper, Roper Theatre, Council Bluffs, Iowa.

"The war tax is a good argument for better organization in the future."—Peter Magaro, Star Theatre, Harrisburg, Pa.

"The tax on motion picture theatres is an outrage, but the motion picture men have only themselves to blame. If they had any sort of organization, the politicians would have been afraid to touch them."—Frank Cook, Princess, Milwaukee, Wis.

THEN WHY DON'T YOU DO YOUR PART?

**HAVE YOU \$100
To Throw Away?
SEE PAGE 17**

COAST EXCHANGES EXPOSE SYSTEM OF FRAUDS

Plan Under Way for Forming an Organization to Protect Managers of Renting Establishments from Unscrupulous Exhibitors—Black List for Bad Payees and Those Who Operate Poor Machines That Ruin Films—Will Also Settle Poster Charge Question

Special to THE MOTION PICTURE NEWS

San Francisco, Oct. 5.

A MOVEMENT is on foot in San Francisco to form an organization of film men, to include those conducting exchanges and handling feature attractions, and within a short time it is anticipated that an association of some kind will be under way.

This move is being taken on account of the heavy losses that have been sustained of late by a number of exchanges which have been made the victims by unscrupulous exhibitors.

The matter has been under consideration for some time, but was brought to a head a short time ago by the exposure of the operations of an unusually bold pair of exhibitors, who had victimized not only many exchange men, but a number of theatre owners, as well.

Within a space of less than two months more than a half a dozen local exchanges have been defrauded out of sums ranging from ten dollars to more than one hundred dollars, but it was only recently that it was discovered that an organized campaign of deception was under way.

This pair of operators would secure leading feature attractions and show them in theatres on a commission basis, often defrauding the theatre owner, as well as the exchange man.

How Two Swindlers Worked

At times they would represent that they had just taken over a prominent house and would secure the films before the exchange had an opportunity to verify the report of the change in management.

The matter culminated when an effort was made to defraud the local office of George Kleine Attractions, and one of the perpetrators of the scheme was arrested. An offer was made to settle the matter out of court, and this was accepted, owing to extenuating circumstances, but a warrant is still out for the arrest of the other party, who is declared to be the ringleader of the two.

Profiting by this experience, several film men agreed that an organization of some kind was necessary, and a call for a meeting was made through the following circular letter issued through the office of George Kleine Attractions: "It has long been the writer's contention that the film exchanges of San Francisco could be operated more advantageously to the betterment of all, if co-operation was secured, and there is no reason in the world why such co-operation cannot be secured.

Advantages of Exchange Association

"Every line of business has a protective association to shield and guard against theft, and our business, the most

exposed of all, has absolutely no protection. If we formed a co-operative association, or club, the protection and saving to each and every one would be surprisingly large in the course of three months.

"We could maintain a black list for bad payees, a black list for those who operate cheap machines and ruin our films, and we could by agreement, one and all, procure the proper charge for posters, and many other important items which we are now overlooking simply because we are not co-operative.

"It will not be necessary to maintain an office force to conduct the policy of co-operation, as we can conduct this business through an agency such as, for instance, the International Mercantile and Bond Company. This is for the good of all, and the quicker we form this association to protect ourselves, the quicker we reap the results, and a greater harmony will exist than ever before dreamed of."

A preliminary meeting was then held during the lunch hour at a prominent down-town cafe, and the proposition discussed in an informal manner. The sentiment was decidedly in favor of action along the line indicated, and the proposition will be taken up shortly in earnest.

Handsome Quarters for Box Office

The Box Office Attractions Company is fitting up handsome quarters at 107 Golden Gate avenue, San Francisco, and will be ready for business within a short time.

The offices and film rooms are of large size, and the appointments are

equal to almost anything in this line to be found here, indicating the confidence the concern has in this field and in the productions it will handle. No announcement has been made here of the manager who will be in charge, but it is understood that a local man has been selected.

Mayor Rolph of San Francisco has vetoed the resolution of the Board of Supervisors granting permission for transient amusements to be established here during the Exposition year. In taking this stand he said that the city should keep faith with the Exposition management, and should discourage amusement concessions outside the fair grounds, except those established in permanent structures.

Mayor Vetoes Concessions

This action on the part of the mayor is appreciated by motion picture exhibitors generally, as it means that there will be but few of the catch-penny, fly-by-night attractions here in 1915 that usually follow great expositions.

An ordinance has been passed by the City Council of St. John, Ore., establishing a censorship committee to pass on all motion pictures, vaudeville performances and other public functions. It is the duty of the mayor, under the ordinance, to appoint a committee of twelve citizens to carry out the provisions of the measure.

Myron E. Hicks, proprietor of the Star Theatre, Ashland, Ore., passed away suddenly of heart failure in that city on September 18. He was well known in Coast amusement circles. A wife and child survive him.

New Horsley "Home Release" a Single

Friends Suggest in Fifty-six Letters and Seventeen Telegrams an Appropriate Name for Producer's Most Important Feature

ALL department heads and employees of the Centaur factories and studio at Bayonne have been ordered to report one hour earlier and to remain at their work one hour later each day until further notice.

Contrary to the general supposition regarding the cause of this seemingly severe order, the war in Europe is in no way responsible.

Mr Stork is all to blame. David Horsley's family has increased, and the cost of living is at present so abnormally high that an increased income will be necessary to meet the demands of the new Horsley.

Yes, it's a boy—and not only that, but it arrived on the same day and almost at the same hour as the contracts which settled the arrangements for the Centaur comedies to be released through

the General Film Company were signed.

The new Horsley home release, though a single, is at present the big feature among the Horsley products, and, needless to say, will not be seen on any program for some time to come.

Mr. Horsley has invited his friends—and their name is legion—to suggest an appropriate name for the baby, and up to the time this story is going to press, seventeen telegrams and fifty-six letters from all parts of the country have been received.

Mrs. Horsley, who has to be consulted in this matter, is not greatly taken with any of the names so far suggested, so Mr. Horsley threatens, in the event of the fifty-seventh variety letter failing to furnish forth an acceptable "moniker," to call the youngster John and let it go at that.

Film Magnates at Mastbaum Dinner

Representative Gathering at Bellevue-Stratford, Philadelphia—Noted Producers Are Guests—Banquet Held in Honor of Carl H. Pierce—Speeches Between Courses Instead of at the End—Flashlight Taken at Beginning Ready by the Third Course

MEN prominent in the motion picture industry as producers, manufacturers, distributors and representatives of the daily papers and of the trade journals were the guests of Stanley Mastbaum at a banquet at the Bellevue-Stratford, Philadelphia, Thursday evening, October 1, which was tendered to Bosworth's Special Representative in the East, Carl H. Pierce.

The table, in the shape of a huge M, was set in the Red Room of the Bellevue and the affair was in the nature of a sequel to a similar banquet given at the Adelphia recently by Mr. Pierce to the newspaper men and others in the trade.

Among the prominent guests present were: "Pop" Lubin; Adolph Zukor, president of The Famous Players Film Company; Daniel Frohman, managing director of the same concern; Jesse L. Lasky, president, and Samuel Goldfish, treasurer and general manager of the Jesse L. Lasky Feature Play Company; Raymond Pawley, treasurer of the Paramount Pictures Corporation; Carl H. Pierce, special representative of Bosworth, Inc.; J. Louis Breiting, Chief Censor of Pennsylvania; Jules Mastbaum and Stanley Mastbaum, of The Stanley Company; William E. Smith, Famous Players Exchange,

Philadelphia; the dramatic critics of the daily newspapers—Howard Bonte, "Ledger"; A. D. Ferris, "Evening Telegraph"; Harry Knapp, "Inquirer"; A. B. Diamond, "North American"; Herman Dieck, "Record"; F. V. Armato, "Evening Telegraph," and the trade paper representatives, Julian M. Solomon, Jr., THE MOTION PICTURE NEWS; Steve Talbot, "Billboard," and the members of the three big distributing companies, J. H. Butner, Mutual; J. C. Hennessy, General Film; Vernon R. Carrick and William Sachsenmaier, Universal, and many prominent exchange and picture theatre managers.

Speaking Between Courses

Stanley Mastbaum opened the evening's festivities with a few remarks, after which he followed the ancient custom of passing around a loving-cup from which each guest partook as he was introduced to those assembled.

This made for good fellowship from the start and they could not be strangers to each other after such a cordial introduction. It was like a great, big family gathering. Everybody talked to everybody else without restraint or without the usual aloofness found at formal banquets.

This was probably helped along by the fact that nobody was allowed to

come in "open face" clothes. Mr. Howard Bonte broke this rule because, as he said, "I was tired of wearing the same clothes all the time and I changed to get a little pleasure."

After the introduction, a flashlight was taken and before the third course had been brought on the guests were looking at proofs of the picture. Between the various courses the innovation of having the various speakers talk was introduced, so that the usual monotony of hearing several men speak one after the other at the end of the banquet was done away with and the intervals between courses pleasantly filled in.

Early Motion Pictures

Jules Mastbaum told of the first store show which he had opened in Philadelphia in partnership with "Professor" Lubin (whom all know as "Pop" Lubin) and Harry Davis.

This little place seated eighty-nine people, and was nothing but a corner store with a white painted front and some undertakers' chairs. The first reels shown ran from fifteen to fifty feet, and the people hardly had time to be seated before they were ushered out again.

Since that time he has been more or

(Continued on page 52.)



FLASHLIGHT OF THE DINNER GIVEN TO CARL H. PIERCE, SPECIAL REPRESENTATIVE OF BOSWORTH, INC., BY STANLEY MASTBAUM AT THE BELLEVUE-STRATFORD, PHILADELPHIA, OCTOBER 1.

In the foreground may be seen Siegmund Lubin, Jesse L. Lasky, Adolph Zukor, Samuel Goldfish, Daniel Frohman, Raymond Pawley, Stanley Mastbaum. Others around the "M-shaped" table are William E. Smith, Carl H. Pierce, J. H. Butner, E. L. Perry, Vernon R. Carrick, J. Louis Breiting, State Censor, A. Fleisher, George Mann, J. C. Hennessy, Jules Mastbaum, Al Boyd, William Heenan, C. C. Pippin.

BUFFALO UP IN ARMS OVER INCREASED PRICES

Exhibitors Protest Against Action of Local Branch of General Film in Making a Flat Rate of Ten Dollars Per Reel Irrespective of Length, Run or Age—Managers See in War Tax Need of Strong Organization

Special to THE MOTION PICTURE NEWS

Buffalo, N. Y., Oct. 7.

ON October 1 the local branch of the General Film Company raised its feature film service to a flat rate of ten dollars per reel, irrespective of length, age or run. First-run will cost the same as sixth or seventh.

Almost simultaneously with this announcement a meeting of the most prominent exhibitors in Buffalo was called to consider the proposition. They had the price, they could take it or leave it. In the words of one of the managers present, "they left it."

This raising of film service at a time when expense at the operating end of the theatre is at its greatest height, seems to be a most unpopular move, if the consensus of opinion among local exhibitors can be taken into consideration.

Under the new rule, a theatre which shows in the evening only is charged the same as an all day and night theatre. If the feature is five reels in length "evening performance" houses must pay \$50 for the production. As one manager said, "We simply cannot afford it. In fact, we will just drop it all together. There is plenty of open booking firms where we can get features at reasonable prices."

Exhibitors Must Stand Together

Speaking of the situation, this same manager said, "This is just another instance when the exhibitors should have co-operation. Not co-operation for this one proposition alone, which when settled is broken up and each manager again falls back into the same old method of 'putting one over' on another exhibitor.

"The only thing for Buffalo film men is organization and 'sticktoitiveness.' If every exhibitor in town will take a firm stand on this increase in service and refuse to show the features, there would be some good done.

"But until such a time as there is a general co-operation, that will be permanent, exchanging and the government will continue to impose upon us.

"If we had had a strong national organization, when the Democratic Ways and Means Committee proposed that \$100 levy on all theatres in towns of 15,000 population, that same committee might have reconsidered their proposal."

Said another manager who was present at the meeting: "We will have to look elsewhere, that's all, we cannot afford such exorbitant prices."

"Legitimate" Lowers Price

Two of the local legitimate houses have lowered their prices during the past week. The Lyric has made their matinee prices ten cents for over five

hundred seats and the front rows twenty-five cents. In the evening the prices are fifteen, twenty-five, thirty-five and fifty. The Majestic has lowered its top price for evening performances from seventy-five cents to fifty cents, and made a flat rate of twenty-five cents for all matinees.

It is the consensus of opinion that the motion picture has been the cause of this decrease. The Lyric has a stock company, while the Majestic shows the second-class productions, such as "Mutt and Jeff," "East Lynne."

The new Palace Theatre, on Shelton Square, will not be opened to the public until January 1. This theatre will cost \$100,000, and will be controlled by the Mitchell H. Mark Realty Company, and managed by Harold Edel, in conjunction with the Strand, Buffalo.

The Regent is the first theatre in town to have girl ushers, and the idea is a popular one. The girls are much more polite than boys, and more reliable. This is just one of the "different" things at the Regent.

The crowds are thinning out at Shea's Hippodrome. It is doubtful whether at

twenty-five cents the present policy will succeed.

Capacity at the Regent

Manager Arthur C. Willats, of the new Regent Theatre, at the corner of Main and Utica streets, reports that during his opening week he has done capacity business. The Regent is one of Buffalo's most beautiful houses. Mr. Henry Marcus and his orchestra are pleasing the audience with his excellent music programs. George Kleine's "Spartacus" was booked for the Regent last week at no increase in prices.

The new uniforms on the ushers at the Strand Theatre are attracting much attention, for they are by far the most attractive in Buffalo. They are patterned after the West Point cadet uniform, are brown in color, with black trimmings and rows of brass buttons.

Manager F. S. MacFadden, of the Allendale Theatre, has issued a local bulletin, which he distributes weekly in his territory. The little paper presents a very attractive appearance. He announces his policy in the first issue and invites local notices of interest which he will be glad to print.

New Organization Launched in Cincinnati

Name Will Be Selected Later On—Prominent Exhibitors Behind the Move—Bernardi Sells Out Interest

Special to THE MOTION PICTURE NEWS

Cincinnati, Oct. 6.

A NEW organization of "live-wire" exhibitors is being formed in this city for the purpose of co-operation, interchange of ideas and mutual progress and benefits.

As yet it is in a temporary form, although it is bound to become an important factor in the growth of the motion picture industry in Cincinnati, according to the men who are responsible for its being.

So far, they have established headquarters in the Savoy Hotel and held several meetings. The new organization is as yet without a name. Charles Weigel, manager of the Alhambra Theatre, is the temporary president. The object of the few exhibitors who have thus banded together is to compose their membership of high-class, and thoroughly representative motion picture men.

They must stand for everything that is progressive in the business. The membership to date comprises the following theatres and managers: Alhambra, Weigel and Harris; Orpheum, Hettisheimer; Nordland Plaza, Brown; Park and Northside theatres, Kruse; Park Theatre, Hyde Park, Stratton; Arcade and Burnett theatres, Avondale,

Foster; Lyric, Covington, Ky., Marcus.

E. P. Bernardi, manager of the Colonial Theatre, has sold out his interests to his partners, the Huss brothers, and is preparing to leave the city, to locate in San Francisco on or soon after December 1.

Mr. Bernardi established the first motion picture house in Cincinnati eight years ago, and has been successfully engaged in the exhibitor's end of the business here since.

Clay E. Brehm, who has been in charge of the local office of the World's Special Films Corporation for three months, having succeeded G. J. Trask, declares Cincinnati is fast becoming a live feature town.

Brehm less than a year ago placed the first feature in Cincinnati when he induced Manager Weigel of the Alhambra to show "Social Life in New York" and "Mysteries of Paris," in which Brehm himself appeared as a member of the acting cast. He is now enthusiastic over increased business. Exhibitors, he says, are taking well to the company's new colored photo posters and large frames which are furnished with them to display five or six photos of the Schubert and Brady features in their lobbies.

ROE S. EASTMAN.

"SHORE ACRES" FOURTH ALCO RELEASE

The fourth release of the Alco will be "Shore Acres," produced by the All-Star Feature Corporation. The scenario



SCENE FROM "SHORE ACRES"
(All-Star Alco Feature)

was written by Louis Reeves Harrison. There is a much larger scope for the screen version of Mr. James A. Herne's classic, through the ability of the All-Star being able to take the scenes in the exact locale of the story, Block Island off the New England Coast.

"Zudora" Is Next Thanhouser Serial

Marguerite Snow Will Be Heroine of Fascinating Oriental Tale to Succeed "\$1,000,000 Mystery"—Goodman the Author, MacGrath the Novelist

"ZUDORA," another absorbingly interesting serial, is to be produced by the Thanhouser Film Corporation as successor to "The Million Dollar Mystery." Daniel Carson Goodman is the author of the new serial, which will be released in two-reel episodes, each of which will be a story complete in itself.

Harold MacGrath, who novelized "Kathlyn" and "The Million Dollar Mystery," will write the newspaper version of "Zudora." All the newspapers throughout the country now running the "Mystery" story have taken unto themselves the new serial. Dr. Goodman, through "The Escape," "The Battle of the Sexes" and a large number of other Broadway successes, has a definite value to the exhibitor booking Zudora.

Mr. MacGrath's name is so well known that it is an attempt to beautify the beautiful, to enlarge upon the merit all know is his possession. In Zudora will be more scenes than in all the plays of the Bard of Avon, a distinction in itself. The title of the first Episode gives an idea of the mystic theme on which Zudora is predicated. "The Mystic Message of the Spotted Collar" is the title of the first release. A cast of three principals will run through the twenty episodes, supported by one thousand people, a construction never before attempted in photoplay production or, for that matter, on the speaking stage.

Marguerite Snow, whose Countess Olga in "The Million Dollar Mystery," has cemented her in the hearts of a

nation's motion picture fans, will play Zudora. She is wonderfully fitted for the role, which will give admirers the opportunity to see this young woman at her best, the role demanding the complete gamut of emotions and a more definite histrionic ability than is the usual requirement.

James Cruze, the reporter-hero in "The Million Dollar Mystery," will play Hassam Ali, a weird oriental character, around whose mysticism revolves much of the story. Harry Benham, whose



MARGUERITE SNOW

work as a Thanhouser leading man is well known, will play John Storm, the young lover of Zudora. This newest of great serials will be presented by the Thanhouser Syndicate Corporation.

Cosmos Will Release Two Features a Month

Company Secures All of Beulah Poynter Productions—"Made in America" Name of New Brand Adopted by Producer

"MADE in America," a label we are so anxious to see conspicuously displayed on the bulk of the merchandise of the world, will make its appearance on a new brand of feature film on October 15, when the Cosmos Feature Film Corporation releases the first of its bi-weekly American-made productions.

As renters of multiple reel subjects the company has been for a long time closely associated with the men in actual touch with the public and the announcement that they will produce an American feature regularly every two weeks, is significant as a summary of the market's trend.

Another point in the announced plans of the company is the selection of subjects. The first release will be an elaborate photoplay version of Beulah Poynter's dramatization of the extremely successful American play, "Lena Rivers," in which Miss Poynter is featured in the title role, the part she played in the stage production. This bill will be followed by "The Little Girl That He For-

got," "The Hoosier Schoolmaster," "A Thief in the Night," and other successful dramatic works of Beulah Poynter's, all of which have been secured by the Cosmos company; also many successful plays and novels, which contain a strong human interest appeal.

When possible, it is their intention to secure the services of the author or dramatist to assist in the film production and feature the same star that created the character on the stage.

It was in keeping with this plan that in contracting for Miss Poynter's plays, it was stipulated that she give her personal services and advice in the making of the photoplays, a condition Miss Poynter, enthusiastic in the art of photoplays, eagerly agreed to.

With the advent of the Cosmos' bi-weekly productions, the film industry will have added to it a regular brand of features, which, backed by the insight into the needs of the market held by this company, should do credit to the label, "Made In America."

BUYS FEATURES FOR MIDDLE WEST

Alfred Hamburger, president of the Celebrated Players Film Company, accompanied by Felix F. Feist, its general manager, spent a week in New York recently buying feature pictures for the weekly release program recently launched by the Celebrated Players Film Company of Chicago, through its Middle West territory.

A string of newspapers throughout this section will carry a serial story of each of these releases operating in conjunction with the local theatres playing the Celebrated Program of weekly features.

WHAT ORGANIZATION MEANS TO EXHIBITORS

Theatre Managers Tell "The Motion Picture News" What They Consider the Essential Features and Duties of An Exhibitors' Body—Los Angeles Men Endorse League—Exhibitor Must Be Shown, Says Omaha Man—"Make Every League Man an Organizer."

Special to THE MOTION PICTURE NEWS

Los Angeles, Oct. 5.

MOTION picture exhibitors of this city—to judge from the expressions of a dozen or more—believe the Motion Picture Exhibitors League of America will prove of great benefit to the business and serve to bring about certain standards and improvements. All heartily endorse the action taken at the Dayton convention.

"We are all a little bit too selfish in respect to giving our time and attention to such an organization," W. H. Clune, of the Clune Amusement Company, told THE MOTION PICTURE NEWS representative. "A national, state and local organization of this character, all working together in harmony could work wonders.

"When I entered the motion picture field here there was but one organization, the Theatrical Managers' Association, which was and is now affiliated with a national organization. I became a member of this and still attend meetings regularly.

"By co-operation the members of this body have been successful in bringing about improvements in conditions, preventing injurious competition among ourselves, and so forth.

Co-operation in Emergencies.

"As all local theatres, with the exception of the Morosco Burbank, show pictures—some regularly and others only when no other attraction is booked—I believe all managers could be induced to become members of a local branch of the exhibitors' league.

"In this state there is more or less jealousy between people of the north and south part, and there has been very little co-operation except when conditions were urgent.

"But let the conditions warrant prompt attention and the co-operation is a certainty, as was demonstrated recently when an ordinance was introduced in the city council to require the exclusion of all except licensed operators from the machine booths, and 60 per cent. of the exhibitors were present at the hearing to fight the measure. I will be glad to do my part for a national state, and local organization, free from politics and petty matters."

In the opinion of E. H. Emmick, manager of the Los Angeles Golden Gate Film Exchange, two meetings of the National League annually, one in the East and one in the West, would do much to create interest in the organization.

Conventions in East and West.

"We in California feel that we are a great distance from the conventions,

and it is too expensive for many film men and exhibitors to attend the annual meetings," Mr. Emmick said.

"With two conventions, which could be made general condition conferences, fully twice as many could attend. Such a meeting would be of great aid to manufacturers and exhibitors generally, and the exhibitors particularly.

"Exchange men are the first ones sought when exhibitors have troubles, and it is no more than fair that film men be accorded membership—at least honorary memberships. In Los Angeles the exchange men have done more to regulate and aid the exhibitors than has the exhibitors' organization.

"Personally, and I believe every one connected with the Golden Gate Exchange, from Sol Lesser down to the exhibitors' league has hit upon a surely successful educational campaign in securing THE MOTION PICTURE NEWS to carry interviews from men in all parts of the country relative to needs for a bigger and better national and state organization."

To Fight Adverse Legislation.

"The necessity of organization in order to fight adverse local legislation in the state and the nation, should be sufficient basis of appeal to all exhibitors to unite with the nearest local organization of the exhibitors' league," Judge A. P. Tugwell, president of the Los Angeles exhibitors' organization, and a member of the executive committee of the national league, said when questioned.

With regard to representation in the national body, and dues for state and national organization, Mr. Tugwell believes the constitution adopted at Dayton fully and impartially regulates the matter.

"A plan the San Francisco exhibitors attempted to put into effect last winter, in order to increase the membership of the league there, might be used in modified form to increase the membership of the Exhibitors' League of America," is the opinion of David Bershon, of the California Film Exchange, with offices at San Francisco, Los Angeles, and Phoenix, Arizona.

Mr. Bershon then explained that officers of the exhibitors' organization first secured the co-operation of all film exchange managers to the extent that the league was offered control of the rental of films.

It was planned that only members of the league would then be eligible to rent films, thus forcing all to join.

"Every exhibitor should be a member of the league," said Mr. Bershon, "and I believe the theatre men will find it to

their advantage to have the co-operation, support and assistance of the exchange men in matters of many different characters.

"The league should not be an organization holding meetings for the purpose of permitting exhibitors to air their jealousies and petty opinions pertaining to the business."

**HAVE YOU \$100
To Throw Away?
SEE PAGE 17**

The League Must Show the Exhibitor Its Worth

Special to THE MOTION PICTURE NEWS

Omaha, Neb., Oct. 5.

"**T**HE possibilities of the Motion Picture Exhibitors League of America, would make a highly interesting story," declared Frank Harris, the former president of the state league, and manager of the Empress, the largest theatre that is showing a picture program in the State of Nebraska.

"Its functions and duties are manifold. In fact, it is all right now, only ———.

"And that is just the trouble with all new organizations. So many things connected with organizations and policies have to be met with. There is always a great deal of discouragement that is bound to come in the organization of any great movement.

"The Motion Picture Exhibitors League of America, in its national, state and local organizations, has an unlimited field of action. The organization of this institution and the bringing of it to its greatest efficiency can only be accomplished by profiting by the experience of some institutions that have gone before and proven successful.

"Before a complete success can be registered, some one thing must be done. This one thing can be anything that is of general importance. As soon as the league enters into a controversy or takes upon itself some of the troubles that are confronting the exhibitors in the country and succeed in definitely settling and winning for the exhibitors, some one big point, its greatest battle will be over.

"Then every little exhibitor in the country will be able to realize the advantage offered by being a member of this organization, and success will come a great deal easier than it is coming.

Advocates Paid Organizers

"It is my opinion that the best example to follow is that which was established by the labor unions of this coun-

try, and that paid organizers are essential. Men whose duty it is to gain new members and spread the bond of good fellowship and the necessary confidence of the exhibitors at large.

"The policy for the national league, in my opinion, is to endeavor to deal with, and help the manufacturers in obtaining an understanding with the exhibitors. Also to co-operate with any exhibitor or group of exhibitors or state league that is having trouble with antagonistic legislation.

"The state league should deal with antagonistic legislation and any troubles that may come between the exhibitors and the exchanges from which he gets his pictures and supplies.

"The local has an abundance of work and opportunities for work in dealing with their individual members and obtaining more members. They also should endeavor to establish and maintain the highest possible standard of the picture business. As far as the national is concerned our members individually will contribute their good will and assistance in any movement which is toward the betterment of the league as a whole.

Big City Locals Must Lead

"The greatest good, however, can and must be accomplished in the states where there are more than 270 motion picture shows, as in Nebraska, and undoubtedly impetus to our organizations must come from the locals of the big city organizations, such as Chicago and New York.

"In Omaha there are only twenty-four exhibitors and these are of all classes possible. There is very little common ground on which to work.

"The day in which the Motion Picture Exhibitors League of America will take a prominent position in the picture industry is very close at hand, is my opinion. The exhibitors shortly will come to see that it is to their greatest interest to unite and meet common difficulties collectively. The day when any petty police officer or bigoted police official will take it upon himself to impose his position on the small exhibitors, has passed. We undoubtedly could exert a powerful political influence if we chose to do so.

"Collectively our screen will reach more than any single newspaper in circulation in the world today.

"Make Every League Man an Organizer!"

Special to THE MOTION PICTURE NEWS

Minneapolis, Oct. 6.

ELIMINATE the insincere exhibitor, make every member of the state organizations an organizer and then get all the live exhibitors that remain, into the fold.

This is in brief the way a wide awake exhibitor sees the way out for the state and national associations. The man is Charles E. Van Duzee, proprietor of four houses in Minneapolis.

Mr. Van Duzee is a man who has

built up his business by hard study and hard work. He is the type of man who could best get along without the help of a state or national organization, yet he is the very man that has faith in them and believes they will become powers in their work.

"The state organization has been a vital help in my business and in the business of other members," said Mr. Van Duzee. "The national organization must exist as a vital force to keep the motion picture business away from the control of politicians. Therefore, both must be improved until they approach the idea.

Exhibitors Blind to Interests

"Mental blindness in the exhibitor is one reason we have had such a fight for success. The motion picture field has too many fly-by-nights who want to get quick money and too many business cutthroats. The man who spends all his time trying to get the other fellow's patrons and no time in making new patrons for films in general, has no place in this business. These we must eliminate. Then 'go after the wheat.'

"The national league can be made the liveliest and most efficient business organization in the country if:

"Each member of a state organization will make himself an organizer and bring in one new member.

"Individual members will tell all the others every time they are benefited by the national or state order.

"Exhibitors will give the organizations more opportunities to show what they can do.

"If politics are eliminated from all branches of the exhibitors organizations.

"The business itself needs renovating and the personal side of the business must be emphasized," Mr. Van Duzee believes. He believes that the basis of representation is not so much a factor as the interest that the individual exhibitor will take in the organization.

"Above all," said Mr. Van Duzee, "show the organization respect when you speak of it either to other members or to outsiders. If a man is a member of an organization and knocks it, his friends will rightly think something is wrong with him.

"If you can't find anything to boost in your organization, resign and do your knocking as an acknowledged foe. There is much for the organizations to do, much that they can do and will do if they have the chance. It is a business machine and if it is not used it becomes inefficient."

Individual Effort Important to Get Members

Special to THE MOTION PICTURE NEWS

Louisville, Oct. 7.

"THE efficiency of the state organization will always depend on the activities of the officers thereof. Let me meet the officers of any state league and when I have had time to make an

estimate of them and of their ability, I will be able to give you a pretty good idea of the kind of work the body they represent, is doing."

This is the keynote of the reply made by L. J. Ditmar, president of the Motion Picture Exhibitors League of Kentucky, when he was asked for his opinion, as to how the efficiency of state organizations of motion picture exhibitors might be best increased.

Competent State Heads

"Put competent men at the head of the state organizations, as the first move toward increasing association efficiency and the rest will to some extent take care of itself," he said.

"I do not mean to say, however, that all that has to be done to secure the success of a state organization is to merely secure competent and enthusiastic officers. The effort to line up every man in the state who is concerned in the exhibition of motion pictures should be continuous and unremitting.

"It sounds trite to say that in union there is strength, but it is true nevertheless. Any motion picture man who has ever been called on, for instance, to appear before a legislature where a bill was being considered knows how he was helped in his efforts if he happened to have a united body behind him.

"Even though he may want merely to point out the injustice of some bill which is likely to become law, the fact that he represents more than himself, or more than a small group gives added weight to his protests and gets greater consideration for what he may have to say.

Settling Program Length

"Then, there is the subject of length of program, and various other things of the sort, that may be settled only through agreement. I do not stand for a policy which forces a certain program standard on everyone; but I believe that a uniform policy in this direction can be secured without coercion. There is, in my opinion, no way to secure this end, other than through some central organization.

"State leagues are best financed by the assessment of dues. Representatives in the state legislative body are hardly necessary if the officers are of the proper caliber. Too many persons concerned in the work of the legislative body make for mere unwieldiness, and results are consequently slow.

**HAVE YOU \$100
To Throw Away?
SEE PAGE 17**

"I believe that the financing of the national organization can be best done through a per capita tax collected through the state organizations. To such a fund would be added, of course, the profits from the annual exhibit in New York City."

LIVE WIRE EXHIBITORS

EDITOR'S NOTE.—It is the desire of "The Motion Picture News" to include under this heading novel advertising ideas, successful schemes in the management, decoration and equipment of the theatre—everything, in fact, done by the exhibitor to stimulate his trade. We invite every exhibitor to write us about any new enterprise he has; also to come to us for advice or information along any line. Address: Editor, "The Motion Picture News," 220 West Forty-second Street, New York City

RAISING THE ANTE BY TIMELY ADVERTISING

ARISE in the admission price from ten to twenty-five and fifty cents, with a packed house for every performance for three days, made a new record in the picture business in Boise, Idaho, and one which was accomplished by the Isis Theatre, under the management of David Farquahar.

Business and professional men and society women who had never been in a motion picture theatre before saw the production, complimented the management and declared in the future they proposed to become regular patrons, as they had no idea that they were so real.

Mr. Farquahar advertised the production liberally through the press, by posters in vacant store windows and fancy cards in the hotel lobbies and banks.

In each case he mentioned the advanced price, citing the length of the reel, its cost of production and that the management proposed bringing the best pictures to Boise regardless of cost, if the people wanted such productions.

During the three days the picture was shown there was not a vacant seat in the house at any performance and so many were disappointed in not seeing the picture that it was re-engaged for three days the following week.

The film was secured through the Notable Film Company of Salt Lake City, of which Lou Marcus is manager and which is putting out the Paramount pictures. Beginning October 1, the Isis will run two big feature productions weekly of the Paramount pictures.

THREE-TIME WEEKLY CHANGE FINDS FAVOR

PROCTOR'S Leland is one of the first theatres in Albany, N. Y., to attempt a change of program three times weekly, instead of daily, and as a result is packing them in.

"The Fortune Hunter" drew such houses that it is believed the film will be called on for a return engagement. "Kit, the Arkansaw Traveler" was another winner, and Jack London's "The Valley of the Moon" turned them away.

Evidently the three changes a week policy will remain at the Leland, and rumors say that there will be a twenty-five cent admission, in the near future, at the oldest show house in the city.

WINDOW DISPLAY OF PHOTOS DRAWS CROWDS



DISPLAY OF SCREEN FAVORITES' PHOTOS IN LOS ANGELES DRUG STORE WINDOW

IT was proven recently that photographs of motion picture players placed in a window will attract more attention than anything previously tried. The experiment was made by the Sun Drug Company, with a number of stores at Los Angeles and at other coast cities, and by actual count more people stopped to see the display than were attracted by any other previous showing of any kind.

This has given local exhibitors a tip that it will be profitable for them to cooperate with drug and other store man-

agers for showing of photographs in windows in exchange, possibly for screen advertising for their house in conjunction with the store showing the photographs.

The advantage of a window over a lobby, it is found, is that a more attractive showing can be made, and at the same time it is protected from theft or being injured by sun or rain. In addition, it gives the theatre additional display space, a thing that many exhibitors need but often cannot find.

SCREENING YOUR AUDIENCE

MAKING flash-light pictures of the audience, reducing them to stereopticon views which were projected on the screen, and then offering cash prizes for the first two people to recognize themselves, is a business-getting stunt invented and used by Manager F. O. Adler, of the Auditorium at Riverside, Cal.

"Did it bring business? Well, I guess it did!" the Riverside manager added after telling of the plan. "The flash-light views were made when the house was packed and I made pictures from

several different angles so that the same faces would not show in more than one.

"Three dollars was the first prize and two dollars the second, and the night the pictures were made I told everyone in the audience what I was going to use them for. I believe 99 per cent. came back the three nights the stereopticon slides were shown. That's no exaggeration.

"The business was so good I am going to do it all over again, and that before many weeks have passed."

BLUEGRASS COMPANY INCORPORATES

Special to THE MOTION PICTURE NEWS

Louisville, Ky., Oct. 6.

The Bluegrass Motion Picture Company, Glenarm, Ky., capitalized at \$60,000, has filed articles of incorporation and has been granted a charter by the Secretary of State.

A five-year lease has been secured on 115 acres of land at Glenarm with the option of buying at the expiration of this time. A studio and laboratory is being installed and players organized and the company expects to be in operation within sixty days.

The company will specialize on rural comedy films. The incorporators are: George P. Hendricks, president; A. D. Hendricks, vice-president; George H. Hendricks, secretary and business manager, and Robert H. Williams, formerly with the Selig concern, Chicago, general manager.

VIVIAN RICH PRESENTED WITH COLLIE

Two little admirers of Vivian Rich, the leading lady of Flying A studios, Effie and Georgia Johns, presented her with a thoroughbred collie the other day.

Miss Rich, who is very fond of dogs, appreciates the gift. She has named her dog Guess. The collie is a beautiful specimen of his breed and has been greatly admired. Miss Rich takes keen delight in being asked the name of her new pet.

Without a smile she will say Guess, and of course the inquirer calls to mind every conceivable name. Not being successful the usual inquiry is "Well, what do you call him?" Miss Rich will then smile and say "Guess." The inquirer turns away with "I'm on."

ALCO PROVIDES MUSIC WITH FEATURES

The Alco Film Corporation have signed a contract with Professor Winkler, a well-known composer, whereby he will write special music for each film that is released through this exchange. The composer will have an opportunity to review the release several times, and will then write music descriptive of the story.

The first orchestration, that of "The Nightingale," in which Miss Ethel Barrymore is starring, has been delivered to the Alco company.

LATEST BOSWORTH RELEASE A PLAY OF POWER

The latest release, "Hypocrites," of Bosworth, Inc., is a four-reel drama written and produced by Lois Weber.

The sin of hypocrisy is handled in a highly dramatic and artistic manner, making a release of interest and originality. Courtenay Foote is cast as Gabriel, an ascetic, and Margaret Edwards plays the Spirit of Truth.

Sawyer Release Full of Laughs

"Thirty Minutes in Melodrama," Second Production of Santa Barbara Company, Has Old Time Villain and "Villainess" Doing Funny Stunts

"THIRTY Minutes in Melodrama," the second production of the Santa Barbara Motion Picture Company, shortly to be released through Sawyer, Inc., is a novel two reel comedy.

ing rooms. Next we see the audience watching the stage presentation "in three acts and eighteen scenes."

Every device used in old-fashioned melodrama is humorously exploited—



SCENE FROM "THIRTY MINUTES OF MELODRAMA."
(Sawyer Comedy—Two Reels.)

The plot deals with an old-fashioned traveling melodrama troupe, which strike the town of Hickville. It is a scream from start to finish—a rip-roaring burlesque on the old time troopers that should be heartily welcomed in every picture house.

Particularly amusing are the company jealousies, displayed in scenes in the country hotel, and in the theatre dress-

the villain, the "villainess," the hero, the heroine, the old Rube, the young Rube and the Rube girl are all there, not to mention the sheriff and a few other characters never absent from such a show.

The hero saves the heroine from an untimely death in waves of waving canvas, from a bomb, and many, many other times from the villain's wiles.

Kansas City Censors Harken to Reason

Appeal Members Reverse Unfavorable Decision of Censor Who Had Refused to Pass "Damaged Goods"

Special to THE MOTION PICTURE NEWS

Kansas City, Mo., Oct. 6.

THE censor of the local bureau refused to pass the American Film Company's production of "Damaged Goods," the sociological play written by the Frenchman Brieux, when it was before him. Richard Bennett had performed the play at the Shubert Theater last spring, and practically no complaint was registered against it then.

**HAVE YOU \$100
To Throw Away?
SEE PAGE 17**

The local censor board expects little trouble here as a result of the showing of war pictures. Fred F. McClure, the censor, announced a few days ago that he would not go to the extreme meas-

ures that had been taken in some of the Eastern cities in regard to these pictures.

"Any picture that might stir up racial feeling and hatred would, of course, be condemned," he said. "But I do not anticipate such films."

Only one war film so far has been up for review. It showed the preparations of the Belgian and English troops to take the field, and was passed without comment.

One five-reel film, "Alone in New York," a white slave drama, was refused by the censor recently. Several other films of a similar nature had been refused previously.

The censor has passed the World Film Corporation's five-reel subject, "Mother," played by Emma Dunn, with the most laudatory comments, saying that similar pictures would always find a ready field in Kansas City.

GEORGE E. QUISENBERRY.

Music and the Picture

Editor's Note.—This department is prepared to answer all questions from exhibitors relating to the use of music in connection with photoplays, and to suggest suitable music for current pictures. Correspondence will be welcomed

Songs of the Last Decade for Pictures

NOTHING can get on one's nerves so much as the piano-player in the picture house who insists on playing (?) in the same key, the same tempo, and often the same selection through an entire reel. An exhibitor could get that kind of music from any automatic piano with the added advantage of slowing it up or vice versa, and even change the selection by substituting another roll.

Why an exhibitor should pay a salary to a pianist for that kind of "playing for the pictures" is a question many a suffering patron is trying to puzzle out. Certainly the box-office receipts are not swelled to any appreciable extent by any such music.

I spoke to a certain manager on the subject one evening, when he and I were standing to one side of the lobby, as the patrons were coming out. Two ladies and a gentleman in a party of six came over to where we were standing, and, addressing the manager, the gentleman acted as spokesman:

"Say, Dave," said he, "where did you get the 'jewel'? How many does that make? This last one would give a body the 'willies'."

The first part of the conversation was all Greek to me, and, as I was not the party addressed, did not pay much attention to it. But when Dave turned to me and said, "Here is a man, Mr. K—, who might be able to tell you, and I'll leave it to him," I was still in the dark. The situation was saved, however, by Mr. K— saying, "Why is it that Dave cannot get some one to play the piano who will at least try to fit his music to the pictures?"

"Blending with the Pictures"

It seems that this theatre up to a month previous had a piano player who seemed to have a selection for no matter what was shown on the screen and changed his tempo and varied his minor and major keys so unobtrusively that his music seemed "to blend with the picture," to use the manager's own words.

Salary was no object, and this last was the sixth attempt to get another player like him. The expression, "blend with the picture" interested me at once, and I got the manager to one side, and,

believe me, he was in some fix. The audiences in his theatre were so used to having pictures "played up to," that he was up against it to get another player that would please them.

I have often contended that the old songs that "mother used to sing" should be used wherever they would fit the picture, in preference to an instrumental selection. There was a man who used "She May Have Seen Better Days," "I'd Leave My Happy Home for You," "Hello, Central, Give Me Heaven," "In the Gloaming," "Darling Nelly Grey," "Climbing Up the Golden Stairs," "Go In and Out the Window," "Bird in a Gilded Cage," "Moth and the Flame," and so forth.

Had His Music by Heart

His repertoire seemed boundless, and he knew by heart practically every song that had made a hit in the last twenty years, to say nothing of the Old Home Songs. He never used a light at the piano except when accompanying the singer, and while the pictures were on played entirely in the dark. It is too bad that there are so few pianists who render that style of picture playing. Too many depend on the so-called "incidental music for the pictures" as published by Blank and Company.

In the article on this page of the September 26 issue of THE MOTION PICTURE NEWS, by E. A. Ahearn, he states that "Some day the music publishers will wake up to the fact that there are numerous picture theatres in the United States and that many employ pianists who are looking for music to fit the pictures. I am glad that some one has come forward and advocated what has been lacking ever since music was insisted on for an accompaniment for the pictures.

I could mention over one hundred songs and melodies that, though old, would be immediately recognized by the average audience and would be appreciated, if rendered to any special scene of a picture where they would fit in.

Some Old Favorites

For instance: "Hello, My Baby," making appointment for elopement by telephone; "I'd Leave My Happy Home for You," or "Go In and Out the Window," if eloping through a window; for trouble in the house, "She Was Happy Till She Met You," or "You'll Be Sorry

Just Too Late." How many think of using the old songs, "Comrades," or "Sweet Marie," or "Daisy, Daisy"?

If you want to please an audience, give them what will appeal to the most of them. By playing a late hit you appeal to a few, or by request you may play the latest musical comedy hit, but for the pictures use a good old song wherever possible. Use "On the Banks of the Wabash," "Old New Hampshire Home," "After the Ball," "Little Brown Jug," "Pop! Goes the Weazel!" Just as the Sun Went Down," "Just Break the News to Mother," and others.

Bring in the old songs as well as the new and you'll have your audiences with you.

Now, don't misunderstand me, and think that you should cut out the up-to-date popular songs and dances, entirely; but do not limit your stock-in-trade to only the tunes that the younger element is whistling. Always remember that the average audience is composed mostly of grown folks and even a few old ones, who would greatly appreciate hearing a melody that was associated with their youth.

H. S. FULD.

**HAVE YOU \$100
To Throw Away?
SEE PAGE 17**

BEST MUSIC NONE TOO GOOD

IF you have music use the best of the kind that your particular patronage demands. This is the music motto of P. F. Schwie, manager of the Lyric Theatre, 720 Hennepin avenue, Minneapolis.

Edith Helena, star with Aborn and other grand opera companies and a noted high soprano, was engaged for the week of September 27. She sang with a program of Paramount pictures.

"You can't do anything to improve good films but you can spoil them with bad music," said Mr. Schwie.

FIDDLERS WITH PICTURES

SOME of the greatest of the old-time fiddles are to be found in the mountain counties of Eastern Kentucky, a number of whom were entered in a big

fiddling contest recently at the Perry motion picture theatre, Whitesburg, Ky.

The only restriction on the contest was that nothing but the old-time tunes be played, among which were: "Buck Creek," "Pigeon Wing," "Sourwood Mountain," "Turkey in the Straw."

THE HEAD OF THE LUBIN PLANT

Among the captains of the motion picture industry Ira M. Lowry, general manager of the Lubin company, stands as a master of his art. Not yet twenty-seven years of age, he ably directs the enormous Lubin plants of Philadelphia and Betzwood, which employ seven hundred people and manufacture 3,000,000 feet of films a week.



IRA M. LOWRY

Mr. Lowry is familiar with the financial, artistic and mechanical end of the business. He is recognized as foreman of all departments, and is equally at ease in the studio, scenario room or factory, to which he gives valuable aid.

CENSORS GIVE LIFE PHOTO FILMS CLEAN BILL

Leonard Abrahams, of the Life Photo Film Corporation, has just returned from a trip through the Middle West, where he has closed out eleven states on the last two releases of the Life Photo Film Corporation's "Northern Lights" and "Captain Swift."

Mr. Abrahams at the same time exhibited the pictures to the various censor boards in the territory covered by them, and found no difficulty in having them passed without cutting, except in Chicago, where the censor eliminated from "Northern Lights" three scenes, from "Captain Swift" two scenes, and changed one title in "Captain Swift."

This is considered quite an achievement in view of the known severity of the Chicago censor board.

New York League President Answers Charge

A. N. Wolff Declares There Is No Truth in the Accusation That He Neglected His Duty in Not Calling Fusion Meeting

Special to THE MOTION PICTURE NEWS

Rochester, N. Y., Oct. 7.

PRESIDENT A. N. WOLFF, of the New York state branch of the Motion Picture Exhibitors League of America was highly incensed and indignant over the report printed in the New York papers of the statement issued from the headquarters of the Motion Picture Exhibitors' Association of Greater New York, at the Hotel Marlborough-Blenheim, New York City.

The report charged him with neglect of duty in failing to call a meeting of the state branch to promote the amalgamation of the regular body with the men who bolted the organization some time ago.

The statement says that strenuous efforts have been made to bring about an amalgamation of all exhibitors in accordance with the spirit of the resolu-

very simple. All the former members have to do is to apply for reinstatement, accompanying their applications with their dues, and they will be received.

"That is what the league agreed to do, and the officers stand ready to do it. I do not see how we can be asked to do more. The Ohio state organization at its recent meeting endorsed the stand I have taken in the matter, and I am very grateful for the support accorded me," concluded President Wolff.

ARTHUR R. TUCKER.

TWO NEW FIRMS FORMED IN KENTUCKY

Special to THE MOTION PICTURE NEWS

Louisville, Ky., Oct. 7.

The Knickerbocker Theatre Company, with an authorized capital stock of \$5,000, divided into shares of \$100 each, has filed articles of incorporation. The company will operate theatres and motion picture shows. The debt limit is restricted to the amount of the capital stock. The incorporators, holding five shares each, are: C. W. Barnes, C. R. Smith and J. L. Duncan, of Louisville.

The Vaudo Amusement Company, of Louisville, has been granted amended articles of incorporation increasing its capital stock from \$1,500 to \$5,000.

The Thoroughbred Film Company, Louisville, Ky., with an authorized capital stock of \$50,000 divided into shares of \$10 each, has filed articles of incorporation in the Jefferson County Clerk's office. The concern will manufacture films and other articles used in motion pictures. There is no limit to the indebtedness. The incorporators are: D. W. Bonar, five shares; Harry Plock and J. Reginald Clements, who hold three shares each.

**HAVE YOU \$100
To Throw Away?
SEE PAGE 17**

tion passed at the last national convention at Dayton, and that the reason no definite results have been accomplished is to be found in the attitude of Mr. Wolff.

The statement goes on to say that the officers and many members of the New York state league, and the executive committee of the New York state association, have requested Mr. Wolff to call a meeting of the association to carry out the work of amalgamation, and to hold an election of officers of the combined organizations.

Mr. Wolff has turned a deaf ear to these requests, and, the statement says, the work of organization in this state is at a standstill until such a meeting can be held. It is said that steps are being taken by the members to call a special meeting, under the bylaws.

The correspondent of THE MOTION PICTURE NEWS called on Mr. Wolff here to reply to this statement. Mr. Wolff made his attitude clear in a few words. He pointed out that the resolution at Dayton agreed to receive the bolters from the M. P. E. L. of A., as soon as they made application, individually, for reinstatement, accompanying their applications with their dues for three months in advance.

"It was agreed that no initiation fee should be charged, but that the privilege of returning to the fold without initiation fee should expire on November 1. This has never been questioned.

"The New York state branch stands ready to receive the former members on the terms mentioned in the Dayton resolution," said Mr. Wolff. "It is all



SCENE FROM "THE PURSUIT OF THE PHANTOM" (Bosworth)

Manufacturers Will Hold Exposition Meeting

Motion Picture Trades Association Sends Out Call for Conference on October 20 to Perfect Plans for Next Exposition Under Their Auspices—Officers for Ensuing Year and Permanent Committees Will Be Elected—General Interest in Plan Is Already Manifest

THE plans of the Motion Picture Trades Association for an exposition to be held under the auspices of that body are being rapidly pushed. As stated during the latter part of August, a large meeting, to which all manufacturers are invited, will be held on the 20th of October, for the purpose of considering the plan. A letter has been sent to manufacturers of films and accessories, calling attention to this gathering, which will take place at the Hotel Wellington, New York City.

The present officers are: F. J. Rembush, president; Carl Anderson, vice-president; W. A. Johnston, treasurer; A. H. Byrd, secretary.

Officers and directors for the ensuing year will be elected at the meeting of October 20, necessary committees appointed, and a permanent organization effected. General interest is being manifested in the association and their plans for a manufacturers' exposition. A large and representative attendance at the October meeting is expected.

Ask Trade's Co-operation

Dear Sir: This letter is of considerable importance. Will you kindly read it through carefully, and let us have your reply at once?

You have undoubtedly heard of the movement among the manufacturers to control and conduct the next national exposition of this industry.

This movement has now taken a concrete start, and awaits your active co-operation.

For your information, the history of the movement is briefly as follows:

It started definitely at Dayton, Ohio, at the time of the exposition there in July last. General dissatisfaction was expressed by the manufacturers present over the lack of attendance, space charges, general expense, etc. This feeling was greatly added to by the previous and utter failures of the Toronto and Wilkes-Barre expositions. Moreover, even in the case of the two largely attended New York expositions of 1913 and 1914, it was felt that the manufacturers had been charged an unnecessarily high rental for floor space.

The Beginnings at Dayton

In other industries, notably the automobile and electrical trades, the manufacturers themselves hold their national shows with all around success, and with the important result that previous floor rentals were more than cut in two.

With these ideas in mind, those manufacturers who were exhibiting at Dayton, or their representatives, met spontaneously in several meetings, during which a preliminary organization was formed, temporary officers elected and an assessment of \$10.00 levied upon each member for preliminary expense.

The committee on organization consulted with Job E. Hedges, of New York City, who had organized with success the Automobile Accessory Dealers' Association, and upon Mr. Hedges' advice, application was made for a charter under the Membership Corporation Laws of the State of New York. These laws are designed especially for mutual benefit associations, and are distinct from the ordinary corporation laws of a commercial or industrial character.

The name, "Motion Picture Trades' Association" was decided upon, a charter was secured, and a constitution and by-laws were adopted. The association is therefore now a corporate body, ready to do business. Nothing further than this has been done or determined upon.

The comparatively few men active in the movement thus far would have appreciated your help from the beginning, but some one had to start the matter, and they

feel that what has been done so far will meet with your approval. All minutes and papers are open for your inspection.

Meeting Called for October 20

You are urgently asked to attend the first annual meeting, which will be held on October 20, 8 p. m., at the Hotel Wellington, Seventh avenue and Fifty-fifth street, New York City, where the management has gratuitously offered a large room for our use.

At this meeting, regular officers will be elected, committees appointed, and a general organization effected. Membership is limited to one member for each firm. You or your representative will have equal voice with all other firms in the organization and management of this association.

The general idea is to divide pro rata the profits of the show among those manufacturers who exhibit, thus reducing the floor rentals. However, this and other important matters will be discussed and decided upon at the meeting.

Kindly write at once to the address above, of your ability to be present at the October 20 meeting.

Your suggestions are invited.

Respectfully yours,
MOTION PICTURE TRADES'
ASSOCIATION, INC.

Famous Players Ready With New Dramas

Company's Second Quarterly Release Through Paramount Will Have Striking Array of Distinguished Legitimate Stars

IMPORTANT as was the first three months' program of the Famous Players Film Company released through Paramount Pictures, the second section of that program contributed by the Famous Players even surpasses the former galaxy of celebrated stars and plays in degree of national prestige and popularity.

The program for December, January and February reveals for the first time the fact that the Famous Players Film Company had induced Florence Reed, one of the most prominent of the younger stars of the day, to appear before its camera in her first film characterization, "The Dancing Girl," the famous emotional drama by Henry Arthur Jones. Florence Reed has just attained a great personal triumph in "The Yellow Ticket."

"The Straight Road," a masterpiece of the late Clyde Fitch, is also introduced by the Famous Players to the motion picture public.

Mary Pickford is represented on the program by a subject entitled "The Stepsister," which, it is intimated, will cause a genuine surprise, and by the charming romantic play "Mistress Nell." "The Million," Henry W. Savage's great comedy triumph, is also scheduled for forthcoming release, presenting Edward Abeles in the principal role.

The program further includes: "The Conspiracy," a triumph of the last theatrical season, with John Emerson, its author, in his original role; "The Crucible," by Mark Lee Luther, starring Marguerite Clark in her second film characterization for the Famous Players, and the much discussed production of Wilson Barrett's sublime drama, "The Sign of the Cross," which is at present creating a furore in England.

This array of well known plays includes a wide variety of subjects which have a general appeal.

MARGUERITE CLARK RE-ENGAGED FOR "THE CRUCIBLE"

Marguerite Clark, whose initial appearance in motion pictures will be made in the next release of the Famous Players Film Company, "Wildflower," has been re-engaged by that company to appear in a screen version of Mark Lee Luther's powerful story, "The Crucible," which is to be a subsequent Famous Players' release.

The charm and sincerity which Miss Clark infused into the bewitching role of "Wildflower" indicated her unusual value as a screen artiste, and resulted in her re-engagement by the Famous Players for several other characterizations.

BRING FILM FROM COAST

A messenger of the California Motion Picture Company journeyed from Los Angeles to New York to deliver the print of "Salomy Jane" to the central office, here of the Alco Corporation. Rather than disappoint the various friends and officers of the Alco company who had been invited and who had come from as far as Winnipeg, it is thought that Alco spent over three hundred dollars, in addition to the round-trip fare to and from the Coast.

ROCHESTER MANAGER RECOVERS FROM OPERATION

Special to THE MOTION PICTURE NEWS

Rochester, N. Y., Oct. 7.

John J. Farren, manager of the Victoria Theatre, is in St. Mary's hospital, recovering from an operation for spinal trouble, due to a fall sustained many months ago.

He has had two operations for the trouble, and his condition is reported favorable. In his absence William J. Malarkey, Jr., is in charge of the theatre.

Best Season Yet Is Outlook in Northwest

Less Vaudeville and Fewer "Legitimate" Attractions to Compete with Motion Pictures in Principal Cities from Butte to Portland

Special to THE MOTION PICTURE NEWS

Spokane, Oct. 5.

MOTION picture theatres in the Northwest, particularly those showing feature films, may expect the best season in years, according to the belief of Spokane exhibitors.

The principal reason for this opinion is that the number of "legitimate" road attractions through this section this year probably will be smaller than ever before, leaving the vaudeville houses as the only opposition for the film theatres.

Even the vaudeville shows will be less hard to "buck," because the Orpheum circuit has withdrawn its attractions from all cities in the American and Canadian Northwest except Seattle.

War conditions have made Northwestern Canada far from a fruitful field for the big road shows. Formerly, many of these have made the swing around

Lasky's Mid-Winter Program Made Up

Beginning December 1, "The Ghost-Breaker," with H. B. Warner, and "The Man from Home" Will Be Followed by Belasco Productions

SAMUEL GOLDFISH, head of the Jesse L. Lasky Feature Play Company, Inc., announces the Lasky releases for the second quarter of the Paramount program, and from all appearances, it is as formidable an ar-

with Bessie Barriscale and an all Belasco cast.

The second quarter of the Paramount program begins December 1, and the first release of the Jesse Lasky Company in this quartet will be the "Ghost-breaker," with H. B. Warner and Rita Stanwood, and following this will come "The Man From Home," with Charles Richman, produced in association with the Liebler Company.

"The Rose in the Ring," a story of circus life, with Theodore Roberts in the titular role, comes next. During January the Lasky releases will consist of the "Irl of the Golden West," in association with David Belasco, and with

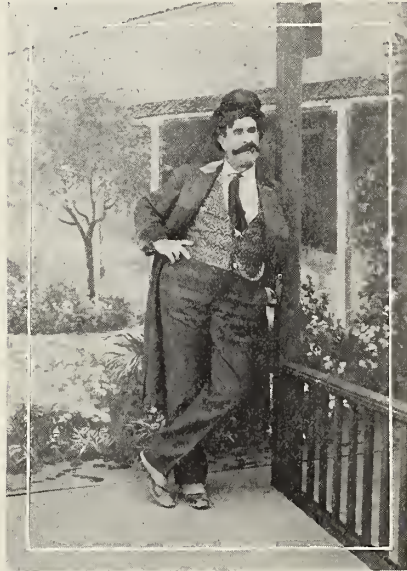

THEODORE ROBERTS IN "THE ROSE IN THE RING"

range of plays as could be conceived.

On the first quarter of the Paramount program, the Jesse L. Lasky Company has released "The Virginian" and the "Making of Bobby Burnit," and within the next three weeks will release "Where the Trail Divides," with Robert Edeson; "What's His Name," with Max Figman; "Ready Money," with Edward Abeles, and "The Rose of the Rancho,"



BESSIE BARRISCALE IN "THE ROSE OF THE RANCHO"

a Belasco cast, and in association with the Liebler company, Dustin Farnum, in "Cameo Kirby."

February will see the Lasky production of the "Warrens, of Virginia," in association with Belasco and with a Belasco cast, and "The Woman," under the same auspices; also with a cast of Belasco players.

Cecil B. and William C. De Mille have long been collaborators with Mr. Belasco, and Wilfred Buckland, at present artistic director of the Lasky company, occupied the same position with Mr. Belasco for many years.

The first Lasky-Belasco picture will be the "Rose of the Rancho," November 16.

**HAVE YOU \$100
To Throw Away?
SEE PAGE 17**

JAN DRUMMOND.

The Exhibitors' Forum

THE MOTION PICTURE NEWS assumes no responsibility for any opinion or assertion made in the columns below, nor does the publication of a letter mean that the statements it contains are endorsed by the NEWS. All letters must be signed. No attention will be paid to anonymous communications

A Lack of Harmony

Editor, MOTION PICTURE NEWS,
New York City.

Dear Sir: Strenuous efforts are being made in this state to bring about an amalgamation of all exhibitors in accordance with the spirit of the letter of the resolution passed at the last national convention at Dayton.

The Motion Picture Exhibitors' Association of Greater New York has held several informal meetings with representatives of the Cinema Club, which forms a part of the membership of the league. The reason that no definite results have been accomplished so far is to be found in the attitude of A. N. Wolff, president of the New York state branch of the M. P. E. L. of A.

Mr. Wolff has been requested by officers and numerous members of the New York state league and also the executive committee of the New York state association to call a meeting to carry out the work of amalgamation and hold an election of officers for the combined organizations. To this request Mr. Wolff has turned a deaf ear, and as far as is known has assigned no reasons for his refusal to act.

Until such a meeting is called, the work of organization in this state is practically halted and there is no strong united body of exhibitors such as would benefit the exhibitors throughout the state.

Steps are now being taken to propose to the members of the state league to exercise their right under the by-laws permitting them to call a special meeting in case the president refuses to do so upon reasonable requests.

Agitation looking toward the accomplishment of this end has been started in this city and it is believed that the national president is in favor of such a move, as it would undoubtedly contribute towards the clearing of a situation which all exhibitors feel is beginning to weaken the league.

During his recent stay in New York this fact was greatly emphasized by the national officers who went on record as saying that the rest of the country looked to New York for an example of peace, harmony and amalgamation.

Yours very truly,

Motion Picture Exhibitors' Association
of Greater New York, Marlborough-
Blenheim Hotel, Broadway and Thir-
ty-sixth street, New York City.

Film Accidents as "News Stories"

October 7, 1914

Editor, MOTION PICTURE NEWS,
New York City.

Dear Sir:—Why is it that the companies manufacturing films which are attended by unusually hazardous feats, endangering the limbs and sometimes the lives of the performers, never advertise the fact?

What I am getting at is this: When the Annette Kellermann pictures were shown in this state, the newspapers would have been glad to make news stories of the fact that Miss Kellermann and her partner were almost killed on one occasion.

Of course, some of the Eastern papers carried the story, but out here "in the provinces" where there are unnumbered thousands of people who daily and nightly go to the pictures there was not a word printed of the danger.

Again, There is the picture, "Through the Clouds." Over a year ago, in a London magazine, I saw a long article which set forth the dangers that beset the young woman in particular when she went into the clouds after her father had been captured by the bandits. Did the newspapers of this section have a line about it? They did not. Did any of the motion picture houses which showed the picture in this section tell about it? They did not.

Don't you know that people would pack these places if they could see where actual danger was being undergone? Just try it once and see.

Very truly yours,

A FIRST RUN PATRON.

Lexington, Ky.

Opera for the Screen

Kansas City, Mo., Oct. 7.

Editor, THE MOTION PICTURE NEWS,
New York City.

Dear Sir: Apparently the film producer is passing up no chances that might lead to the dramatization of acceptable stage stories. That is evidenced by the recent rapid growth of the five and six-reel features of all descriptions.

And to the average observer, it would seem that every field offering interesting drama is being worked by the producer.

But, I want to suggest a new one, the staging of the stories of the grand

operas. At a first glance, it would seem that the lack of action in an opera would militate against its use for the films. But upon reading the stories themselves, one will see readily that opera is not actionless—one will see that it is crowded with dramatic incidents, situations and actions that could easily be produced for the camera.

Take a few of them, for instance, "Faust," "Carmen," "Rigoletto," the Wagnerian productions. None of them would make, perhaps, more than two reels, but my point is that they would be intensely gripping and would draw well.

Much has been said about putting the motion picture on a higher cultural plane and that is being achieved with startling rapidity.

And what, I'll ask, would do this more than the filming of the famous operas of the world? A FILM FAN.

ESSANAY NOT CAUGHT BY WAR

While some film companies have been caught short by the big war, up to the present time the Essanay company has done a brisk business in Europe. Thus far the shipping department of the company has not missed a single foreign shipment, and the average number of Essanay sales abroad compare favorably with the business done before the declaration of hostilities. Harry A. Spoor, manager of Essanay's European office, in a recent letter from the London office, says:

"Your promptness in shipping prints in connection with the present war is remarkable. We have not been held up on a single film, and are doing just as big a business as ever.

TARKINGTON NOVEL IN FILMS

Booth Tarkington's comedy drama, "Springtime," is now in active preparation by the Life Photo Film Corporation. The writing of the scenario has just been completed, and production will begin at once.

The majority of the scenes will be taken where the author of the play originally laid them, in New Orleans and other cities in Louisiana.

The cast of the Life Photo Film Corporation, it is expected, will leave in the course of the next few days for that city to begin active work on the film.

MUTUAL SIGNS LEASE ON NEW CINCINNATI BRANCH

Special to THE MOTION PICTURE NEWS

Cincinnati, Oct. 6.

Arthur Lucas, district manager of the Mutual Film Corporation, was recently in Cincinnati, and with Manager C. C. Hite, of the company, closed a six-year lease on the quarters formerly occupied by the General Film Company, at Seventh and Walnut streets.

The Mutual offices will be moved to this location the middle of next month. Manager Hite said the quarters now occupied by the Mutual in Opera Place were becoming too congested, although improvements were recently made. The move was necessitated to take care of the increased business.

F. E. Hammel, formerly connected with the Mutual office in Cincinnati and well-known to local exhibitors, has been placed in charge of the new Mutual office just opened at 206-8 Inter-Southern building, Louisville, Ky.

FIRE MARSHAL TO PROHIBIT USE OF EXPLOSIVES

Declaring that the destruction of life and property is invited by the careless use of bombs and explosives in moving picture concerns, State Fire Marshal Thomas J. Ahearn has decided to prohibit their use in connection with such entertainment.

Their special liability to produce fire in the theatre, and the danger of premature discharge in their handling, as well as the danger from panic through their discharge, are the causes of the fire marshal's safeguarding actions.

Two More Oz Pictures Completed

"The Magic Cloak of Oz" and "His Majesty the Scarecrow of Oz" Founded on Incidents in the Baum Stories

Special to THE MOTION PICTURE NEWS

Los Angeles, Oct. 5.

DURING the last week the producing company at the Oz studio took up the filming of a comedy drama, "The Last Egyptian," from the novel by L. Frank Baum, which was filmed under the personal direction of Mr. Baum and Charles Hayden, and is the fourth release of this company.

The producing company has now completed, in addition to "The Patchwork Girl of Oz" released through the Paramount Picture Corporation, two other pictures from the Baum fairy tales, "The Magic Cloak of Oz" from the fairy story, "Queen Zixi of Ix," and "His Majesty, the Scarecrow of Oz," being a collection of incidents from several of the Baum stories.

In these productions Violet MacMillan, who played the part of Dorothy in the original stage production of "The Wizard of Oz," and Ojo in the Patchwork film version, is featured. Fred Woodward, the animal impersonator, is seen as the "mewel," alligator and cow in "The Magic Cloak," and as the lion, "sawhorse," mule, kangaroo, crow and cow in "The Scarecrow."

Two New Companies Join Alco Program

B. A. Rolfe Photo Productions and Tiffany Motion Picture Corporation Take Place of Excelsior Feature and the Favorite Players

THE Alco Film Corporation, the announcement of which, several weeks ago created a distinct impression in the motion picture field, now announces that through a series of elim-



B. A. ROLFE

inations and additions, its program is complete, and work has been begun on five distinct productions, one each, of the various allied producing concerns

whose products constitute the Alco program.

Since the previous announcement, the Alco states that the products of the Excelsior Feature Film Company and the Favorite Players Film Company have been eliminated from the program, and the creations of the B. A. Rolfe Photo Productions, and the Tiffany Motion Picture Corporation have taken their place.

Mr. Rolfe, considered by many as the most artistic and best quality producer of the high-class variety stage, will in the future devote his entire time to photo plays.

The Tiffany Motion Picture Corporation composed of prominent and recognized men of the industry, announce that their first production will be the eminent dramatic actress, Leslie Carter, in her best-remembered stage triumph, "The Heart of Maryland." They will send Miss Carter and her company of supporting players to Shenandoah, Virginia, where the principal scenes of the production will be staged, and which vicinity is the original locale of this famous Belasco piece.

Walter Hoff Seely, executive head of the Alco concern, says that the response to the Alco policy is more satisfactory than even the most sanguine member of the corporation had hoped. From all over the United States come in inquiries from exhibitors and exchange men applying for the Alco program.

Al Lichtman's tour of the larger cities has resulted in a compact mass of contracts that portend a most satisfactory launching of the Alco system when the first release occurs.

Mr. Rolfe announces that he has secured sufficient plays and novels to carry his company over a course of eighteen months.

The California Motion Picture Corporation has forwarded the print of "Salomy Jane" to the New York headquarters, and a private showing of it was given in the ball room of the Ritz-Carlton Hotel, to many of the executive and directorate staff of the Alco Corporation.

All in all the Alco Film Corporation comes into the market with the absolute certainty of an excellent start. Its standard of productions and the asserted fact that they contemplate "a live and let live" policy with the exhibitor puts them on an easy-to-reach basis.

UTICA MANAGERS FORM BRANCH ASSOCIATION

Special to THE MOTION PICTURE NEWS

Utica, N. Y., Oct. 7.

The "legitimate" and motion picture houses at Utica, N. Y., have organized The United Managers' Protective Association, of which there is a national body.

**HAVE YOU \$100
To Throw Away?
SEE PAGE 17**

In and Out of Los Angeles Studios

Special to THE MOTION PICTURE NEWS

Los Angeles, Oct. 5.

DOT FARLEY wrote a scenario for a comedy drama, "Matilda's Battle With Cupid," which was produced last week at the Albuquerque studio under the direction of Director G. P. Hamilton. This picture consists of one reel, in which Matilda, a maiden aunt, attempts to protect her two attractive nieces from the men. The scenes are all laid in the West, Matilda being the owner and forewoman of a big ranch. One of the big spectacular scenes is the stampede of more than two hundred head of cattle.

Archer McMackin, comedy producer for the Albuquerque, has finished filming a one reeler, "Two Much Pants," in which the large and small, the fat and lean, all become mixed, when a dog steals trousers from a clothes line, in a neighborhood quarrel, which ends lovely. The comedy company consisted of Anna King, Eva Thatcher, Buck Connors, George Cummings, William Brown, and Raymond Zell.

Louis Fitz Roy, who has been connected with the Richard Willis Publicity Bureau, is now a member of the Albuquerque staff, and in addition to playing parts of importance has charge of the employment of extra people. Fitz is a "showman" of years of experience, and has been connected with several local picture companies in addition to many years of trooping.

The most recent organization to begin operations in Los Angeles is the Rolin Film Company, composed of H. E. Roach, president and general manager; Dwight Whitting, vice-president, and D. A. Linthicum, secretary and treasurer; incorporated under the laws of California, with a capital of \$10,000, all of which has been paid in.

The company has contracts with Sawyer, Inc., of New York, for release of comedies, and recently filmed a one-reeler, "A Barber for a Day," which is a laughmaking burlesque on a correspondence school woman barber.

Will Be Agents for Sawyer

The directing was in charge of H. E. Roach, formerly with the Universal and Pathe companies. In addition to making comedies the company will act as Western agents for Sawyer in the purchase of films manufactured by companies not having a regular release.

Among the members of the producing companies are Harold Lloyd, Gene Marsh, Martha Mattox and James T. Kelly. The company has rented offices

at the Los Angeles Film Corporation studio, 406 Court street.

The first picture of the Masterpiece Film Corporation, "The Hoosier Schoolmaster," featuring Max Figman and Lolita Robertson, was recently completed and given screen examination at the studio. The picture consists of five reels and will be released October 19.

Veterans of the Southern California soldiers' home at Sawtell, near the Santa Monica canyon studio of the New York Motion Picture Company, were the first to see the seven reel feature of this company, featuring W. S. Hart, the picture being projected at the Home,



DOT FARLEY

so that all soldiers who took part in the big scenes could see what kind of actors they really were.

The story for this picture is by Richard V. Spencer and the scenario by Thomas H. Ince, and more than half of the scenes are laid in the Grand Canyon of Arizona. Just what title the picture will be released under has not been announced.

To the producing company the picture was known as "The Bargain," but this has now been changed to "The Two Gun Man." All of the scenes were produced under the personal supervision of Mr. Ince, who, with a company of twenty-five players, camp helpers, carpenters, and stage hands spent six weeks in the Grand Canyon early this summer.

The company experienced many hardships in reaching the desired locations, all of which are north from El Tovar Hotel, seldom frequented by visitors. W. S. Hart will be remembered as star of "Trail of The Lonesome Pine."

George Osborn is absent from his duties at the N. Y. Santa Monica studio, because of a recent fire which destroyed several of the buildings on his raised ranch near Fresno, Cal.

George Beban, celebrity of the spoken drama and vaudeville, famous for his character impersonation of an Italian in his sketch "The Sign of the Rose," was an arrival at Inceville recently, the name now given to the New York Motion Picture Company studios near Santa Monica, where he is playing the name part in a multiple reel feature produced under the personal direction of Thomas H. Ince, which has been named "The Italian." The scenario for this picture was written by Mr. Ince and C. Gordon Sullivan.

George Beban at High Salary

Among photoplayers it is stated that Mr. Beban is receiving the greatest salary ever paid an actor or actress to appear before a motion picture camera—at least on the west coast—and that the weekly stipend is three or four times four figures. The engagement was made with Mr. Beban, by Mr. Ince, after the actor had refused offers of a number of photoplay producers.

"The Master of the House," was recently produced by Richard Stanton, who played the lead at the Inceville studio near Santa Monica. The scenario was by Messrs. Ince and Sullivan, and is considered one of the best short subjects undertaken by this company.

This picture is of a semi-western character, in which a mining magnate is humiliated by the pseudo-rich of New York, is wronged by the girl he weds, and suffers injustices until he returns to his western home where he becomes master of the house.

Exceptionally Fine Settings

The settings are exceptional and Mr. Stanton selected a cast of the most prominent players of the studio.

Mr. Hamilton is of the belief that the organization will result in the various producing companies uniting for the erection of one big studio for the use of all, and as the atmospheric conditions about Los Angeles are the best, and scenes here accommodate producers with almost anything desired, it is very probable the studio, if built, will be located here.

Hypnotism formed the basis for a comedy plot used by Ford Sterling for a picture produced last week, entitled, "The Hypnotist." The jilted lover (Ford Sterling) of the beautiful woman (Emma Clifton) is taught the science and uses it on his rival.

While the rival is unconscious, the new hypnotist throws him in the ocean and secures the girl. Bubbles coming to the surface are seen by the professor of hypnotism who brings the unconscious man to the surface and then in the words of Sterling, "there iss von awful chase."

Henry Otto Goes to the American

Henry Otto, who has been producing for the Santa Barbara Motion Picture Company, releasing through Sawyer, for the past few weeks, is now with the American Company and will produce comedies and dramas of one and two reels.

The leads for this new company will



HENRY OTTO

be Winifred Greenwood and Ed. Coxen, supported by George Fields, heavy, John Stepling, characters, Charlotte Burton, ingenue, William Burton, assistant director, and Tom Middleton, cameraman.

Mr. Otto is one of the most popular photoplayers in California, and until recently was secretary of the Photoplayers Club of this city. He was formerly with Selig, Universal, and produced his best pictures while with the Balboa Company where he made "The Will o' the Wisp" and several other very notable pictures.

One of the notable coming releases for Sawyer, made in California, is that of "Cain and Abel," with Page Peters and Jack Wilson in the name roles and Matty Martin playing the part of the woman.

The picture is of two reels, with sixty-two different exterior locations in the wild country along the ocean north of Santa Barbara. The costume for Cain consisted of black bear skin and for Abel a leopard skin. The woman wore a primitive costume of ferns, ivy and the proverbial fig leaves.

This is an allegorical picture showing

the passions of men, the woman personifying love, and the subtitles consisting of Love, Jealousy, Envy, Hate, etc. The scenario is by Henry Otto who directed the production.

**HAVE YOU \$100
To Throw Away?
SEE PAGE 17**

Charles Clary, cast for the part of Father Kelly, in the Selig production of the Rowland and Clifford play, "The Rosary," was tutored by two local priests in matters pertaining to Catholicism, and proper mannerisms of priests. The film version is a very broad character sketch showing the life of the Father from boyhood—when he renounced his sweetheart for the church—to old age.

Fearing an accident would befall Louis Scherer, in charge of securing locations for the fifteen producing companies of the Universal studios, because of his speedy driving, Manager Isadore Bernstein recently had him exchange the high power car he was using for one with a speed of fifteen or twenty miles per hour.

But Scherer had the "new" car overhauled and it now throws sand at most of the larger ones of the company's garage. As a result, Scherer has had two turnovers during the past week, but he climbed out from under the machine in each instance with but a few minor bruises.

James Dayton, head of the Universal scenario department, is again at his desk after an absence of two weeks caused by a nervous breakdown. For the past several months Mr. Dayton worked day and night in order to keep up with the producing companies. This proved too strenuous for the photoplay scenario writer and his two weeks' illness resulted. Mr. Dayton writes, on the average, four scenarios a week.

No Fatal Results in Auto Accident

"The Fatal Marriage" is the third release of the L. KO. brand, filmed under the direction of Henry Pathe Lehrman, and containing some exceptional auto racing performed by Lew Carter, a professional driver of ten years' experience. Twice the big racing car turned over with Carter when he attempted to make right angle turns while going at forty or fifty miles an hour, but in neither instance was he seriously injured.

Announcement of great interest to users of General program is soon to be made by the Selig Poloscope Company, relative to wild animal pictures. For the past several weeks the six companies at the Selig Jungle Zoo have been filming single reel subjects, which will be released as part of the regular program, at regular rates.

All Selig wild animal pictures of the past have consisted of more than one reel and have been rented at feature prices. Six wild animal pictures have

now been filmed, which include "An Incident of the Jungle," and "The Rajah's Vacation," produced by Manager Thomas Persons of the Zoo.

"Neida" is the title of a one-reel picture produced recently by Harry Polard, of Flying A studio, at Santa Barbara. Margarita Fischer, plays the lead and as a result of barefoot running and jumping in the wilds of San Marcus Pass, where the exteriors were made, the actress is sunburned, scratched and is suffering from stone bruises—the same kind that troubled Skinny.

Joe Harris plays the character part in this picture, which portrays the life of a child of the rocky wastes.

Production of series number eleven of "The Trey O' Hearts" was begun last Saturday by the U Gold Seal Company, directed by Wilfred Lucas. Up to this time the players have tried every conceivable stunt for a thrill and as they near number thirteen they are prone to become superstitious and wonder what the author, Joseph Louis Vance, and scenario editor, Bess Meredith, have in store for them.

George Larkin is just now beginning to feel himself again after two weeks' daily treatment by an osteopath, made necessary by bruises received when he hit the ocean after a leap from the mast of an old ship in San Pedro harbor, a distance of more than seventy-five feet.



AL CHRISTIE

"His Dog-Gone Luck" is the title of Al E. Christie's latest comedy capsule, in which Eddie Lyons, an actor out of a job, is refused another meal because he cannot pay the landlady. Victoria Ford, in love with Eddie, attempts to smuggle him a morsel from the kitchen, but her plan is foiled by the janitor.

Made up as a bad man Eddie plans revenge by holding up the janitor while he is out walking with the landlady's poodle dog, and stealing the dog. Hiding the pet in his room he secures permission to run down the thug, and when

he returns the poodle he becomes the star boarder and the janitor loses his job.

Faust Second Child Drama

The Faust Photoplay Company, with studio at Alhambra, Cal., is now having costumes and props made and collected for a second child picture, to be directed by Charles J. Wilson, producer of "Jess of the Mountain Country," released through the World Film Corporation.

In the coming picture, which will consist of several reels, Edna Mae Wilson, the seven-year-old daughter of the director, who played the name role in the first picture, will be featured. Little Miss Wilson is the youngest star of the legitimate stage in America, having played the name role in Francis Wilson's "The Bachelor's Baby" before she was three years old.

Later she played the part of Delsy in Lawrence Eyre's "The Things That Count," and Dorothy in the K. & E. production of "The Sign of the Rose."

Frank Montgomery, who has served as director for 101 Bison, Universal and until recently with the Kalem company at Glendale, has secured a release through Sawyer, Inc., and has begun producing at the Norbig commercial studio on Allesandro street.

Mr. Montgomery's contract calls for three thousand feet weekly, and these will consist of two reels of Indian drama in which Princess Mona Darkfeather (Mrs. Montgomery) will be featured, and one reel of comedy produced by J. Davis.

The Indian pictures will be released as The Darkfeather Features and the others as Monty Comedies. These two companies and that of Carlyle Blackwell's Favorite Players at the Norbig studio make it a very busy place.

Across the street Mack Sennett, Charlie Chaplin, Mack Swain, Reub Miller, Roscoe Arbuckle and Mable Norman direct Keystone Comedies. One block in the other direction is the Selig Edendale studio, where Colin Campbell and E. J. LaSaint and players are busy all the time. This is truly Los Angeles' busiest filming district.

"One Traveler Returns" is the title of a one-reel picture being made at the Selig studio under the direction of E. J. LaSaint. It is a story of a jealous woman and her attempts to seek revenge on the man who married another. Stella Razeto plays the lead.

Bessie Eyton in "Unrest"

Thomas Santschi last week directed the filming of a two reel psychological picture from scenario by W. E. Wing, entitled "Unrest," which features Bessie Eyton. It is a story of the life of a son of the rich who tries to secure pleasure. A sensational auto race and a marvelous rescue from the sea constitute part of the punches of this picture.

Tom Mix, manager and director of the Selig company at Glendale, making western drama, has been advised to curb his attempts for realistic scenes,

and in the future not to endanger the lives of his people or himself. Recently, Mix, with a steel plate inside his shirt, had one of the men shoot a hole in a star he was wearing while playing the part of a western sheriff.

In another instance he had bullets shot past his head in order that pictures could be secured of the missiles raising his hair. His latest stunt resulted in painful injury. He rolled down a very steep incline and a dozen or more deep gashes were cut in his legs by the sharp rocks.

The dock and water scenes for the



SCENE FROM "OLAF ERICKSON—BOSS"
(Rex—Two Reels)

prologue of "The Rosary," written by Lanier Bartlett of the Selig Edendale studio, were made last week at San Francisco by Charles Clary and Wheeler Cakman, and the Irish village for this section of the picture was erected at Portuguese Bend, about twenty miles up the coast from Los Angeles.

Here excellent sea views were secured which materially aided in giving the picture a true Irish atmosphere.

Director "Sheriff" Arthur Mackley last week began work on the twenty-sixth picture for a Reliance release, in which he appears in the role of the western sheriff. The title of this is "Sheriff for an Hour," in which the western officer and deputies arrest a young crook who had been deceiving his mother by making her believe he was earning an honest living.

Since originating the part of sheriff Mr. Mackley has played in almost two hundred subjects, averaging one thousand feet each, and appearing in about half of the scenes. With sixteen pictures to each foot, his face appears in a total of 1,600,000 motion pictures.

"Now, as to popularity," Mr. Mackley said with a sly smile, "each picture lives about two hundred days, and is shown on the average of four times daily, or eight hundred times.

Some Tall Figuring

"That being the case my million and six hundred thousand pictures have been projected eight hundred times, and there are probably sixty prints of each, making a grand total of 76 trillion, eight hundred million pictures projected on the screen. My star surely is as well known as Roosevelt's teeth and glasses, by this time."

Another newspaper story of two reels, "The Floating Call" is being filmed under the direction of Fred A. Kelsey, at the R-M studio, in which Irene Hunt is being featured as "Helen of the Herald," playing the part of a sob sister.

Miss Hunt recently played such a role in "For the Last Edition." Other members of the cast for this picture are Ralph Lewis, George Siegmann, Vester Perry, W. E. Lawrence and Robert Burns and the scenario is by Russell E. Smith.

Following the custom of English speaking drama, producers and officers of the Reliance and Majestic companies are developing types of their players. Eugene Pallette, has been assigned to the part of crook, F. A. Turner, that of father, Sam De Grasse as detective, and so on through the entire stock company of the studio.

Mr. Pallette is now being featured in "A Woman Scorned," a two reel subject, made under the direction of Jack Adolphi. In this the hearty co-operation of newspaper reporters and police officials result in the capture of criminals in what was first supposed a baffling mystery. Sam De Grasse, Mary Alden and Francelia Billington have prominent parts in this picture.

Good Farce Comedy

"Casey's Vendetta," a farce comedy by W. E. Keefe, is holding the attention of Eddie Dillon and company of Komic brand makers this week. Dillon appears in the role of an officer and employs a gang of black handers to get rid of his wife. The outcome is disastrous to the officer. Other players are Fay Tincher, Tod Browning and Max Davidson.

A decidedly novel situation is brought about in the one reel comedy produced last week by All Curtis and Jokerites at the U studio in the filming of "He Married Her Anyhow."

**HAVE YOU \$100
To Throw Away?
SEE PAGE 17**

HEAVY ADVERTISING FOR "ZUDORA" IN CINCINNATI

Special to THE MOTION PICTURE NEWS
Cincinnati, Oct. 7.

Cincinnati exhibitors are looking forward with interest to the release of the new Thanhouser feature "Zudora," just announced. The success with which the "Million Dollar Mystery" met in Cincinnati has caused the exhibitors to expect great things of the new feature.

"Zudora" is a detective story feature of forty reels, arranged to run in serial form for twenty weeks. C. C. Hite has announced that it will be put on the market behind a greater volume of advertising than "The Million Dollar Mystery" received. The cast will include the same stars as appeared in the "Mystery," with the addition of Harry Benham.

"FARTHEST SOUTH" FOR GOLD FIBRE SCREEN

A Radium Gold Fibre Screen from Atsco, Inc., left on the Floyd Brasileiro Steamship Wednesday, October 7, for Montevideo, Uruguay, where it will be transhipped on board a Pacific Navigation steamship for Punto Arenos, Patagonia, for installation in the Biografía Laville, the only motion picture house there.

Punto Arenos is the farthest city south in the world, being almost within the Antarctic circle.

FIRST ROLFE RELEASE

B. A. Rolfe, the prominent variety producer, whose musical concoctions are known wherever vaudeville of the higher class exists, announces that of the three productions now in course of construction, "Satan Sanderson" will be his first Alco release.

Life Photo Release, "The Ordeal," Ready

Picture, in Five Reels, Makes Strong Plea for Universal Peace—President Wilson, Said to Be Cleverly Impersonated, Featured

THE Life Photo Film Corporation has completed its five-part feature release, "The Ordeal."

The company will exhibit the production to the full censor board, and at the request, it is said, of the President and the Secretary of State. Jesse J. Goldberg, the secretary of the Life Photo Film Corporation, went to Washington, D. C., with a copy of "The Ordeal," to exhibit the film to the representative of the Department of State.

Edward M. Roskam, the president of the company, who cut and assembled the picture personally, states that the picture presents a powerful argument in support of universal peace.

A synopsis of the story was read by representatives of two peace societies, and the picture is likely to receive public endorsement from them.

A tableau finishes the five-part feature, in which the ruling powers of the

Famous Players Preparing "County Chairman"

Screen Version of Legitimate Comedy-Drama Success, with Maclyn Arbuckle in the Cast, Ready on October 26

A NEW epoch in the development of the motion picture industry is marked by Henry W. Savage's initial film offering, Maclyn Arbuckle, in "The County Chairman," by the celebrated

Company that they had formed an affiliation with the noted producer, whereby they would produce in motion pictures all his famous dramatic successes, the motion picture industry and public be-



SCENE FROM "THE COUNTRY CHAIRMAN," WITH MACKYIN ARBUCKLE
(Famous Players—Paramount, October 16)

humorist, George Ade, which immortalizes one of the greatest comedy-drama successes ever contributed to the American stage.

When, a few months ago, it was announced by the Famous Players Film

came vitally interested, and eagerly anticipated the first of these filmed theatrical triumphs, which now, for the first time, is disclosed.

The film adaptation, due to the limitations of the oral stage, permits of even a more vivid and more elaborate interpretation of the plot than was possible in the stage version. The film production is presented with many members of the original cast, including the star and Willis P. Sweatnam, in his inimitable impersonation of Sassafras Livingston.

The play is a blending of quaint characterizations and wholesome romance. The story deals with a rural political campaign, with a tender love story running through the structural web.

The action occurs in the fictitious town of Antioch, but the principles of the drama apply equally to New York or Chicago, for one touch of politics, like that of nature, makes the whole world kin.

The production, which is in five parts, will be released on the Paramount program October 26.

RAMSEY IN NEW YORK

L. H. Ramsey, the Lexington, Kentucky, exhibitor, prominently identified with the Kentucky Photo Play Feature Club, recently went to New York, to secure new feature films for his organization.

Mr. Ramsey is a man of broad experience in the film business.

**HAVE YOU \$100
To Throw Away?
SEE PAGE 17**

Motion Picture News

HAS THE QUALITY CIRCULATION OF THE TRADE

MOVING PICTURE NEWS EXHIBITORS' TIMES

Published Every Week by

EXHIBITORS' TIMES, Inc.

220 West 42nd Street, New York City.

TELEPHONE BRYANT 7650

Chicago Office, 604 Schiller Building

WILLIAM A. JOHNSTON.....	President
HENRY F. SEWALL.....	Vice-President
E. KENDALL GILLET.....	Secretary
H. ASHTON WYCKOFF.....	Treasurer
WENTWORTH TUCKER.....	Ass't Treasurer

WILLIAM A. JOHNSTON.....	Editor
LESLEY MASON.....	Managing Editor
WILLIAM RESSMAN ANDREWS.....	News Editor
H. ASHTON WYCKOFF.....	Business Manager
R. M. VANDIVERT.....	Advertising Manager
E. J. HUDSON.....	Circulation Manager
C. J. VERHALEN.....	Chicago Manager

This publication is owned and published by Exhibitors' Times, incorporated under the laws of the State of New York. The offices and principal place of business are at 220 West 42nd Street, New York City. The address of the officers is the office of the publication.

Entered as Second-Class matter at the New York Post-Office.

Subscription \$2.00 per year, postpaid in the United States, Mexico, Hawaii, Porto Rico and the Philippine Islands. Canada, \$3.00; Foreign, \$4.00 per year.

ADVERTISING RATES ON APPLICATION.

Copy for next issue must reach us by Tuesday, 5 p. m.

For Releases see Pages 72, 74, 76, 78, 80

For Buyers' Guide see Page 70



Cuts and copy are received subject to the approval of the publishers and advertisements are inserted absolutely without condition expressed or implied as to what appears in the text portion of the paper.

Vol. X

October 17, 1914

No. 15

Fixing the Blame for the War Tax

“THE tax on motion picture theatres is an outrage. But the motion picture men have only themselves to blame, for if they had any kind of an organization, the politicians would have been afraid to touch them.”

This is the situation that confronts the exhibitors of the country today, as Frank Cook, of Milwaukee, one of the oldest and best known film men in the business, sees it.

Mr. Cook's words are as true as the condition he describes is unpardonable.

* * *

THE exhibitors have only themselves to blame. Every exhibitor who has persisted in remaining a “free lance” has only himself to thank for the additional burden now to be lifted to his shoulders.

Every exhibitor who has failed to support a state or national exhibitors' organization in the past, is PERSONALLY RESPONSIBLE for the fact that he and his fellow-exhibitors are threatened with a crushing tax to meet the expenses of the Government.

THE MOTION PICTURE NEWS hopes every one of these exhibitors will realize—as sooner or later they must—that, if they had done their duty toward themselves, this tax would not now be threatening their very existence, as exhibitors.

And should the leaders of the organization, which these “free lances” have scoffed at and pooh-poohed, succeed in lightening the burden of this tax for them, this paper also hopes that every one of these exhibitors will acknowledge their error and pay their debt by supporting the organization in the future.

It will be the least they can do, as men and as exhibitors.

* * *

IT has always been the boast of these “free lances” that they could get along without organization. They didn't want to co-operate with anybody, and they didn't want anybody to co-operate with them.

They will now have the privilege of paying \$100 a year, or whatever the Government sees fit to charge them, for their independence.

That is only justice.

Independence, such as they cling to, is the costliest luxury in the world. If they did not know it until now, again they have only themselves to blame.

They should pay and pay well for it.

The only regrettable feature of the situation is that hundreds of exhibitors, wise enough to see that the good of all is their own good, and broad-minded enough to be concerned for the welfare of their fellow-exhibitors, should have to pay for the ignorance and stupidity of a few.

* * *

THERE is one lesson to be learned from the present crisis, which cannot be driven home too quickly or too deeply.

Let there be an end, from henceforth, of the old, silly, exasperating cry: “What can a national exhibitors' organization do for us?”

None but a national organization can do anything at the present juncture.

If this tax is modified in any way to make it easier for the exhibitors to bear, the credit for it will belong to the national organization.

If this tax is lightened so that small exhibitors throughout the country will be saved from bankruptcy, those exhibitors will owe their commercial existence and their future prosperity to the present national organization.

* * *

AND, if the tax now before Congress is readjusted through the efforts of the national organization, and there still remain exhibitors who will continue to refuse to support that organization, their extinction will be a boon to the business.

The motion picture industry will be well rid of them.

The “News” Will Go To Washington

THE display of exhibitor sentiment on the war tax question, to be found elsewhere in this issue, is unique in the history of the film industry.

It belongs in the hands of the Federal legislators who are preparing to tax motion pictures. And it will be there. Marked copies of this issue are being sent by the “Motion Picture News” to the chairman of the Senate Finance Committee, the chairman of the House Ways and Means Committee, and other leading Congressmen.

Sawyer Will Release Japanese Pictures

Company Contracts for Output of Nippon Firm Featuring Plays with Famous Actors of the Land of the Rising Sun

SAWYER, Inc., has just made several affiliations interesting to the trade. Chief among these is the contract by

color Company. He was the manager of the Kinemacolor Theatre on Fortieth street, New York, and directed the pub-



SCENE FROM "THE OATH OF THE SWORD."
(Sawyer Feature—Three Reels.)

which they will market the productions of the Japanese-American Film Company, an organization owned and controlled by Japanese business men, who have assembled an aggregation of Japan's most famous actors, to produce photoplays of unusual merit.

Their first presentation is "The Oath of the Sword," a three-reeler. It is based on the custom of hari-kari, and shows an entirely new treatment of the subject for dramatic purposes.

The Phoenix Film Company also makes its initial bow to the public. Through Sawyer, the new San Rafael, Cal., concern has released its five-reeler, "The Fight for Right; or, The Napoleon of Labor." It is a startling and unique treatment of the labor situation, combining a strong love interest with many exciting scenes concerning a great labor strike, which is finally won by peaceable methods.

The first production under the Liberty brand to be marketed by Sawyer will be a four-reel drama of the conventional East and the wild West, called "Hearts United." This company is also making single real comedies which will be included in the Sawyer program of seven one-reel comedies each week, which is to start in the near future.

Much interest is being taken in "The Loves and Adventures in the Life of Shakespeare," by exhibitors all over the country. Another film which has scored an instantaneous hit is "Doc," from the story by Eleanor Gates in the "Saturday Evening Post."

The co-operative publicity bureau of the Sawyer offices is now being organized by Edwin Bower Hesser, for two years publicity director of the Kinema-

licity for both the "Coronation" and "Durbar" productions.

Lately he has personally been producing grand opera in New England and Canada, as well as holding the position of managing director of the Maritime Booking Association, with offices at Halifax, N. S.

WAR NEGATIVE ARRIVES

A refugee brought to the Universal office the first scenes taken in and around Berlin, showing some good close-ups of Commander-in-Chief Von Kessel and Foreign Secretary Von Jagow; typical scenes of the grenadier guards in front of the Berlin Imperial Palace, and scenes of cannon drawn by Cossack horses captured from the Belgians, French and Russians. They are vivid scenes, and the staff cameraman of the company, who, it is said, marched to the front with the troops, procured these scenes at great risk. The picture will be shown in coming issues of the "Animated Weekly."

RETURN ENGAGEMENTS FOR "THE VIRGINIAN"

Through a typographical error there appeared last week a statement to the effect that Dustin Farnum was at the Universal studio while rehearsing in "The Virginian." It is needless to remind exhibitors that this play was put on by the Jesse L. Lasky Feature Play Company, and the mention of the Universal was a "slip of the linotype." The film is destined to have a long run and probably in numerous instances will play return engagements.

WOODWARD SIGNS FOR THREE YEARS WITH OZ

Cosily housed in one of the many beautiful California bungalows, Fred Woodward, the king of all animal impersonators, has at last begun to enjoy life.

For years Mr. Woodward has been eagerly sought after whenever an animal has been needed in the cast of any of the big New York productions.

His experience covers animals of every description from alligators to cab horses. He has been with Weber & Fields, Ziegfeld's Follies, and many others, his last work on the legitimate stage being a mule in "The Tik-Tok Man of Oz."

But after trying pictures, Fred Woodward bows and declares he will never return to the stage. He seems to mean it, for he has just signed a three-year contract with the Oz Film Company.

His wonderful work in animal skins has fooled many people, for Woodward prides himself on being absolutely true

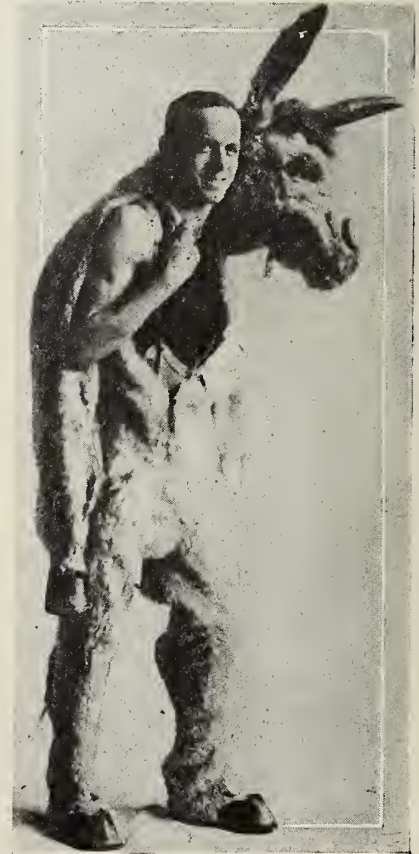

FRANK WOODWARD

to life. At one time, while playing a broken down cab horse in Ziegfeld's Follies, some one in the audience reported to the Humane Society that they were using a horse that should be attended to by a veterinary.

An officer was immediately dispatched to the theatre, and when he learned that the horse was nothing but a prop with a man inside, he was as furious as an official in his ludicrous position might have been expected to be.

"MARTA OF THE LOWLANDS"

(Famous Players—Five Reels)

REVIEWED BY PETER MILNE

MME. BERTHA KALICH is the latest star that the Famous Players have recruited from the legitimate stage to the screen. In "Marta of the Lowlands" she makes her debut into the field of motion pictures, in a production that well deserves her fame and her remarkable histrionic ability.

It has been a long time since a picture such as this has made its appearance. Perhaps in less skillful hands it might have been offensive, as the story is very delicate and has to be dealt with in a corresponding manner, but it comes far from being offensive as it is told in this picture.

The production is constructed in the most skillful manner. A series of powerful situations, each one almost a climax in itself, leads up to an even stronger denouement. Little rapid action puts in its appearance, but the picture is one of the few that do not need action to carry them through. It is safe to say that if the situations that prevail throughout the picture were absent, little would be left of the entire five reels.

It has fallen to Mme. Kalich to carry the bulk of the acting. Her part is a most sympathetic one, and she interprets it in her well known style, which is extremely emotional. Wellington A. Playter is cast as Manelich, the young and innocent shepherd. He acts his part well, only at times appearing just a little bit too childish in his actions. Hal Clarendon gives a good impersonation of the Master, and not much pity is extended to him when he breathes his last. Lillian Kalich appears as Muri, a young girl, and plays a small part well.

Scenically and photographically the picture comes up to the usual Famous Players standard. The sets are good, but seem



"COME, MARTA! LET US GO TO THE HIGHLANDS"

a trifle more artificial than most of those appearing under this brand.

Marta is a beggar child, who is practically forced to live with Sebastien, a land owner, who is "master" of his people. Sebastien exercises great cruelty over Marta, and at length makes her his victim, in body, but not in mind.

Being sorely pressed for money, he wishes to marry and sees no other way than that Marta must marry too. She weds a young shepherd, who, finding out that he has been misinformed regarding the character of the woman, kills Sebastien, and returns to the Highlands to live a happy life with Marta. The scenes are laid in Spain.

"M'SIEUR BLUEBEARD"

(101 Bison--Two Reels)

REVIEWED BY PETER MILNE

THIS, the third picture of Universal's Francois Villon series, vies with its two predecessors in regard to the elements that have been combined to create the impressive and exciting tales of these monthly stories.

The sly and scheming character of Villon is perhaps the

most noteworthy characteristic of this picture, one which will be well apparent to all. How he executes a task set for him by his master, Louis XI., is highly clever and amusing, besides exciting.

M'sieur Bluebeard is a powerful personage, holding sway in domains which Louis looks upon with greedy eyes. He commissions Villon to visit this man and report the weakness of his domains.

Instead, Villon goes to Bluebeard, poses as a magician, gains the freedom of the city and goes about stirring the slaves to revolt. This they do, and Villon returns to the king to report his enemy's death.

THE PATH FORBIDDEN

(Excelsior-Alliance—Five Reels.)

REVIEWED BY PETER MILNE

ASIDE from the fact that this picture presents a most absorbing story in the best way possible, it boasts of what can fairly be termed the best double exposures ever witnessed by the writer.

This excellent work is largely due to the efforts of Harry Handworth, the director. It is well apparent that he spent no little time in working to perfect this angle in the picture, and he has come out with unusual success.



HOLMES TO THE RESCUE OF LUCY

The most remarkable thing about the double exposure is, that besides not being able to distinguish the dividing line, a letter and later a bundle of clothes passes from one figure to another across the point at which the film is joined.

Taken in the environs of Lake Placid, the scenics are very beautiful and are backed by good photography. The story, which fits its surroundings well, is entertaining at all times.

Octavia Handworth carries the dual role of two sisters. She also plays their mother, in the beginning of the picture. Gordon De Maine as Holmes is the hero of the story.

William A. Williams plays the father of the two girls in a very fine manner. The rest of the cast is made up of Hamilton Crane, Francis Pierlot, Tom Tempest and John B. Hymer.

At the outset of the story we see the wife of Brill, leading a life which leads to separation from her husband. Twenty years later, her two daughters have grown to womanhood. One, who has been brought up in her care, travels her life; the other, who lives with her father, possesses her father's traits, is lovable, kind and willing.

Fate brings the two girls together, and the meeting eventually leads to the reformation of the first.

**HAVE YOU \$100
To Throw Away?
SEE PAGE 17**

"THE RAGGED EARL"

(Popular Plays and Players—Alco—Five Reels.)

REVIEWED BY PETER MILNE

THIS is a production that may take its place among that class of pictures of which there are very few and to which we hope more will be added in the very near future; that class is composed of comedy-dramas, played and produced by people that are well accomplished in all the necessary arts, that tend to make such a picture perfect.

Even the patrons of the excruciating slapstick comedy and again those that prefer melodrama, or any person who appreciates pictures of one variety more than another, will not fail to be highly amused by "The Ragged Earl."



TRYING TO ACT LIKE A MAN

The picture is in reality just a vehicle for Andrew Mack, the old time Broadway favorite, and his associate players of this picture, to create all the laughter they possible can which, be it known, is not a little.

As far as development of the story goes, the whole thing could be condensed to a reel, but then it would be shorn of all its humor, which as those who stand entirely on technicalities, would term so much padding; but if padding serves to put one in a pleasant humor, it is not noticed, and it would be sadly wanted if neglected.

When the picture was played on Broadway, several years ago, it was a great success, and it was the same star, Andrew Mack, who sent the audiences into spasms of hearty laughter. Much of this, of course, depended upon the words, and the way that they were spoken. It would seem impossible to visualize such a play, and it must have presented great difficulties.

But it may be said to the credit of all those concerned in the making of the picture that they have overcome all these obstacles in a justifiable manner.

In regard to the photography, scenes, settings and the like, the picture may take its place among the best. One would never think that certain nooks in the environs of Philadelphia could be transformed into a second Ireland, but the locale never seems familiar, and it won't, except for those who live in the immediate neighborhood in which the picture was filmed.

The sets have been arranged with apparent care, and some remarkable deep scenes appear, which formerly were only the boast of foreign-made pictures. Throughout the entire five reels nothing but the highest order of photography is prevalent.

The story is extremely simple, at times a little lacking in

**HAVE YOU \$100
To Throw Away?
SEE PAGE 17**

continuity, but as a whole very clearly put. The ward of a penniless Irish noble is engaged to marry a decrepit and grouchy old man, much against her will. She is in love with the "ragged earl," a hail and hearty old Irishman. At length that gentleman impersonates the other and the marriage takes place and then comes the shock to Sir Henry Hardcastle, when he finds that his ward has been married to no other than the ragged earl.

William Conklin plays Sir Henry; Ormi Hawley assumes the role of Kathleen Fitzmorris, his ward; Eleanor Dunn impersonates Una, her little sister, and the part of the old rogue, Lord Wildbrook, is carried off by Edward J. Piel. The director is Lloyd B. Carlton.

"THE MILLION DOLLAR MYSTERY"

(Thanouser—Sixteenth Episode.)

REVIEWED BY PETER MILNE

AS the end of this serial draws nearer and nearer with each week's episode, as thirty-two reels have passed and there are only fourteen more to follow, one is forced to speculate on the final outcome, which perhaps is not so hard to imagine as it is to solve the difficult questions that the story has asked from the start.

Does anyone know exactly where the million dollars is at the present time? If it has been caught sight of at all in the previous episodes, it immediately is put in some out-of-the-way place and the chances are forgotten before it is next unearthed. Then again the coveted box may not contain the million dollars at all.

The success of the serial has been mainly dependent upon this question. When each new installment appears, the populace flocks to the theatre to see if there is not the least bit of light cast on the subject, and the producers, concealing the answers of all questions up to the present episode, have acted wisely in so doing. For this reason the great interest that "The Million Dollar Mystery" commanded at the outset has been sustained in the following chapters.



THE COUNTESS SENDS FOR THE DOCTOR

The award, too, is another magnetic attraction. No one will turn up his nose at ten thousand dollars, and for this reason the onlooker will try all the more to solve the three questions, "Where is Hargreaves?" "Where is the million?" and "Who will marry Florence?"

In this episode a number of startling experiences befall Florence, Susan and Jim. After Susan has suffered a relapse, she repairs to the seashore with Florence.

There a doctor, who is no other than Braine, attends her, informing her that she is well but that Florence has contracted smallpox. She, however, escapes from the conspirators with Jim, but runs into treacherous quicksands, and Jim, who is always ready to aid Florence from whatever plight she is in, mounts a telegraph pole and pulls her out with a rope.

The quicksand incident is most thrilling and is perhaps as hair-raising as the lovers of sensationalism could wish for.

"THE WIRELESS VOICE"

(Reliance-Mutual—Two Reels.)

REVIEWED BY PETER MILNE

DIRECTOR FRED A. KELSEY has produced an admirable picture in "The Wireless Voice." It contains a love story, just prominent enough to hold together the chain of events which revolve about the inventor of the wireless telephone and his marvelous instrument. The inventor of



THE INVENTION PROVES A SUCCESS

this contrivance, J. P. McCarty, also makes his appearance on the film, playing a not unimportant part in the cast.

Although the main trend of events is neglected at times to illustrate the mechanisms of the wireless telephone, it is a very interesting sight to see, and will be warmly welcomed even though they are not absolutely necessary.

In the cast, besides Mr. McCarty, are Irene Hunt and Jack Conway, who assumes the role of the inventor's partner, who is able, because of the invention, to defeat the rascally plans of two unscrupulous men to steal it. Excellent photography marks the entire offering, and coupled with the realistic scenes and entertaining story stamp the picture as one that will surely be a success.

"MISS CINDERELLA"

(Eclectic—One Reel)

REVIEWED BY CLIFFORD H. PANGBURN

A VERY pleasing film, which presents a sort of twentieth century version of the story of Cinderella. The essential facts of the story are just as they were in the old fairy



CINDERELLA LEAVES HOME

tale, but instead the prince is a very eligible young bachelor, while the haughty noble ladies are represented by some ambitious but not too attractive spinsters.

Cinderella goes wading in the brook. The young bachelor goes fishing in the same place. In casting over a bush he hooks one of Cinderella's slippers. He searches for the

owner, but by the time he finds her and plans to marry her the sisters have locked her up. She escapes and is married.

There is an attractive atmosphere running through the entire picture which makes it seem quite different from the general run of short comedies and dramas.

"ON THE ISLE OF SARNE"

(Edison—Two Reels.)

REVIEWED BY J. BURROUGHS NOELL

H. B. MARRIOTT WATSON'S story, "The Picaroon," is used as the basis of this pleasing comedy-drama, in which charming Mariam Nesbit and Marc MacDermott play the leading roles.

It is rare that an ordinary two reel picture of the regular program maintains such a high level of excellence as we have here.

From every angle of observation, this is a good picture; the story is bright and unusual; the acting is clean and finished; the photography is high-class; and the settings entirely adequate.

Dorothea, the part portrayed by Miss Nesbit, is being forced by her uncle, the count, and countess to receive the attentions of a German nobleman, Count Sigismund.

Finally Dorothea rebels right out. She is offered the alternative of going to the Isle of Sarne or receiving the



THE DISAPPEARANCE OF THE COUNT

count. She chooses the former, but on the isle she does not get freedom from the unwelcome suitor, because he is expected to arrive for a visit any moment.

A yachtsman, Peter Seabrooke, loses all of his yacht's supply of food, and lands on the island almost famished. He finds the villa, and is mistaken for Count Sigismund. He tells Dorothea the truth, but plays the part at her request. Soon the count himself is seen approaching in his yacht. Dorothea and Peter go to meet and to escort him in, but lead him off into the woods instead, and tie him.

When he gets loose, he comes to the villa raging, and is cooled off by a good soaking with the hose, the servants performing this service for their mistress.

The upshot of it all is that the uncle comes to the island, but Count Sigismund is no longer the willing suitor, and Dorothea has no better opinion of him than before. She has fallen in love with Peter, and they go off to England together on Peter's yacht to be married.

SUNDAY FEATURES TAKEN OFF AT TECK

Special to THE MOTION PICTURE NEWS

Buffalo, N. Y., Oct. 7.

THE Teck theatre has discontinued the showing of features on Sunday for one reason—poor audiences. The Teck never made much of a success of Sunday motion picture attractions, for which twenty-five and fifty cents was charged.

Only two were shown this year, and now they have been discontinued for the season. The Teck can make money with the legitimate attractions, but when it comes to films, they cannot draw the crowds.

"THE WARNING"

(Eclectic—Three Reels.)

REVIEWED BY CLIFFORD H. PANGBURN

ANY doubts as to the quality of this film should at once be dispelled when it is stated that it presents the age-old idea that "the wages of sin are death," in a way which is forceful, interesting and convincing.

It sometimes seems as if a certain class of directors when hard up for a scenario always turn to a story which is intended to point this moral. The result is that so many thoroughly poor pictures of the sort have been made that the majority of them appear to be burlesques.

In "The Warning" there is a welcome change. The picture



THE REPRIMAND.

has real quality. There is no attempt to be unduly spectacular. Neither is there a large cast. In fact, it is a two-man cast, the other members being a sort of background.

M. O. Penn plays the part of the clergyman. His acting throughout the picture is characterized by extreme depth of feeling, and a great naturalness, even in the most dramatic moment. Creighton Hale, as his son, handles a totally different part equally well. Both players exhibit a most commendable restraint in the matter of gesture.

The reason the story is so effective is that the downward course of the boy—which, by the way, does not actually take place, but is a dream which he has after a drunken debauch—is presented in a logical and perfectly possible way.

A series of small offenses gradually leads him to the commission of three murders. All of his crimes are unpremeditated, and his greatest sin at the start is his failure to control himself.

A minister's son gets into rather fast company, and finally comes home intoxicated. His father reprimands him severely just as he is going to sleep. The rest is a dream.

Starting with the theft of a small sum from his mother's purse, he ends his career of unintentional crime with three murders. When he escapes from jail his father binds him and casts him into the lake where he had drowned a girl, his first victim. When he awakens, the effect of the dream is so strong that the boy vows to mend his ways.

Scriptural quotations used as inserts add to the strength of the general effect.

\$50,000 PITTSBURGH THEATRE READY*Special to THE MOTION PICTURE NEWS*

Pittsburgh, Pa., Oct. 7.

M. BURKHART'S new house, the Imperial, in New Kensington, is rapidly nearing completion, and from present indications the place can be thrown open to the public about October 15. The structure is well located on a lot 40 by 150 feet and is fireproof throughout.

It is the finest house in that section of the country and is also one of the best equipped in this end of the state. The investment will total \$50,000. The capacity of the theatre will, when completed, be 775.

NEW ATLANTA THEATRE USING ONLY BEST FILMS*Special to THE MOTION PICTURE NEWS.*

Atlanta, Ga., Oct. 6.

THE Strand, Atlanta's newest motion picture theatre, and one of the handsomest in the entire South, has just opened its doors at 56 Peachtree street.

No expense has been spared to make the Strand one of the most attractive houses in this section of the country and, in accordance with its architectural perfection, only the highest class productions will be presented.

"THE PERILS OF PAULINE"

(Eclectic—Fifteenth Episode—Two Reels)

REVIEWED BY CLIFFORD H. PANGBURN

PAULINE continues her adventurous career in this episode in a style which leaves little to be desired as far as thrills are concerned. Pearl White and those who support her do some clever acting, and there is some equally clever manipulation of scenes in putting the film together.

The course of the story requires that a thrilling cross-country automobile race be shown, culminating in an accident to the car driven by the villain. Motion picture actors are willing to attempt nearly everything, but one of the stunts at which they draw the line is wrecking a high-power automobile. Of course, dummy figures can be used, but in this film the spectator is offered the real thing.

A series of scenes taken at a famous road race in France supply the wrecks. These portions are mingled so cleverly with parts showing racing machines on American roads that only an experienced and close observer could detect them.

Cars are shown passing around dangerous curves, and as a preliminary, two wrecks are shown. One of them was a fatal accident. The final smashup is the most startling of all, and it is made to appear a mishap to the car in which the villain is riding. This particular villain, who was only a hired tool of the real one, is thus disposed of, and all is well for a time.

The photography of the racing scenes is excellent, as is that of the first reel. One good point, which adds a touch of realism, is the light effect in the first reel during the duel scene.



CAUGET IN HIS OWN TRAP

The duel is supposed to be fought at sunrise. Many duels at the same hour have been seen on the screen, but usually the shadows show the sun to be at a position which it reaches only at a much later time. By the simple process of taking these scenes when the sun was low, and casting long shadows, the right atmosphere is created.

The duel occurs as the result of an insult to Pauline by Ferrari, who has been hired to kill her fiance. The crook uses a poisoned sword, but the versatile hero knocks it from his hand. He then takes it up and hands his opponent the weapon he had been using. Naturally, this ends the fight, as the coward does not dare to face the poisoned blade.

Pauline rides with her lover in the automobile, race, and the same villain attempts to wreck his car. Instead, he is wrecked himself. Needless to say, the hero wins the race.

SPECIAL FILM REVIEWS

"Shorty and Sherlock Holmes." (Broncho-Mutual. Two reels. Wed., Oct. 21.)—This is another of the Shorty series featuring Shorty Hamilton. As usual, it is a mixture of comedy and drama. From reading Sherlock Holmes stories, Shorty gets the fever and imagines himself a detective.

The boys think to play a little joke on him, but in following up their false clue, he comes across two real bandits, whom he captures. The spirit of his companions soon changes from mockery to admiration.

"The Spark Eternal." (Kay-Bee-Mutual. Two reels. Fri., Oct. 23.)—There is a fine story to this picture, one that is well produced and played in a manner to hold the attention. With the reformation of the girl of the slums comes her efforts to reform her sweetheart who is a member of a gang. Her success comes when she shows him the happy family of the doctor for whom she works.

"The Power of the Angelus." (Domino-Mutual. Two reels. Thurs., Oct. 22.)—The locale of this picture is Mexico. The scenes and photography are beyond criticism. Before the Mexican awakes to the fact that his visitor is an adventurer his daughter marries him, forsaking her old lover.

He in despair joins a monastic order and many years later meets the woman when she comes to tell him that her husband is to steal a priceless chalice that night. At the appointed hour the bandits attack the priests who are conveying the chalice to the monastery.

Then the angelus rings out; all except the leader kneel in prayer and he is killed by his companions. The woman is advised by her old lover to join a female order, which she does.

"The Dancer." (Kalem. Two reels. Monday, Oct. 5.)—By featuring the famous danseuse, Mlle. Verna Mersereau, in this two-part picture, the Kalem company has given it the greatest possible reality.

The story is built around a dancer who is loved by a rich man, petted and jeweled by him until he grows tired of her and finds someone that pleases his fancy more. The girl's good fortune turns her head for the time being and she forgets her old mother.

When her short-lived happiness is over, she is drawn to her for comfort, but learns that she is too late. The inevitable happens, and the girl ends all in the murky river.

"Greater Love Hath No Man." (Edison. Tuesday, October 6.)—Beginning with the theme of "Madame Butterfly," the love of an American officer for a Japanese maiden, Mary Imlay Taylor's latest story in pictures breaks away from the old lines and has an entirely different ending.

Here the lieutenant changes his mind and decides to marry the Japanese woman. But he is brought to this resolve by the heroic self-sacrifice which the girl makes for his sake, even taking upon her shoulders a crime with which the officer has been charged. The real

less exciting events they capture him. A realistic explosion of an automobile is shown.

"The Master Force." (Kleine-Cines. Two reels. Tues., Sept. 22.)—The young doctor was forced to leave his love to accept a position in a Brazil mining camp. Here he falls in love with the mine owner's daughter. But the sight of his first love causes him to return to her. Beautiful scenes mark this entire production.

MIGNON ANDERSON LOSES FATHER

Frank Anderson, father of Mignon Anderson, leading woman with Than-houser, died at his home in New York City recently. The deceased was well known as a tenor for a period of twenty-five years, serving in opera, on the dramatic stage and in vaudeville.

His last professional engagement was with the famous Yankee Comedy Four eighty years ago. Since then the deceased was engaged in the insurance business in New York.

Mr. Anderson was known professionally as Frank Armstrong and never lost his interest in the amusement business, being secretary of Brooklyn Lodge, No. 30, T. M. A., at the time of his death. He was also a member of Charter Oak Lodge, F. & A. M., which accorded him a Masonic burial.

Mr. Anderson was born in Baltimore and leaves a widow, known in dramatic circles before her marriage as Hallie Howard; and three daughters, Mrs. G. H. Christoffers, Mrs. J. J. Callahan and Mignon Anderson. Almost the entire Thanhouser stock company and the membership of his lodges were present at Mr. Anderson's funeral services and a room was filled with the floral offerings received.

BROADWAY SETTLES WITH PATENTS COMPANY

After several weeks of conferences, the Broadway Picture Producing Company has come to an amicable settlement with the Motion Picture Patents Company out of court, which covers their entire output since the organization of the company.

Owing to the great demand and popularity of their two greatest productions, "The Trail of the Lonsome Pine" and Thomas E. Shea in "The Man o' Warsman," it was a hard matter to bring about a settlement, as the accrued and future profits of the two above productions run up into large figures, but the entire matter was settled to the satisfaction of both parties.

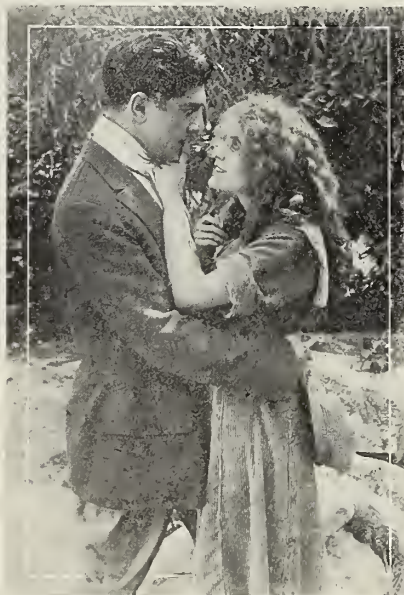

SCENE FROM "REDEMPTION"
(Imp—2 Reels—Sept. 21)

culprit is found in time to save her from execution.

The cast is extremely well selected for the parts, Mabel Trunelle playing Foomi San, the Japanese girl, and Edward Earle, Lieutenant Paul, the lover.

"For the Secret Service." (Rex-Universal. Two reels. Thursday, Oct. 8.)—Robert Leonard and Ella Hall have often appeared in one-reel pictures, but here they demonstrate their ability over a larger expanse of film. "For the Secret Service" is a picture that all will enjoy, due to its absorbing and unconventional story, the excellent way in which it is produced, and the ability of the cast.

Alan Forrest is the other principal character. An inventor and a secret service agent, who happens to be a woman, both combine their forces against a foreign spy, and after count-

War Tax Crisis Reveals Need of Organization

(Continued from page 24.)

He believes it is unfair to add a special tax upon the theatre people, especially when business has been as slow as it has been for the past year and a half.

He cites that when times are hard that the first business affected is the theatre business as the public begins shutting down on the amusements first, *while unlike other business, the cost of operation goes on just the same.* Mr. Bossner feels that a halt should be called, if possible, upon the tax, which he regards as unjust.

Patrons Will Not Stand Increased Prices

T. A. Harrison, manager of the Majestic Theatre at 115 South Tenth street, is opposed to the war tax against motion picture houses as he feels with the \$100 city license and the many other expenses of the business the managers are standing all that they possibly can and if additional burdens are imposed it will hurt the business to an alarming extent and will cause a raise in the admission price which will prevent many people from enjoying an evening of harmless amusement and one which is often instructive.

At best the western motion picture show proprietors are not making more than a good living out of the business, he says, and with an additional burden added, they will be required to make the people pay the tax to keep open.

"Fight the Tax to the Limit"

That the special proposed war tax should be fought to the limit through the national organization and through state organizations wherever possible, is the opinion of H. Kaiser, proprietor of the Kaiser Theatre at 819 Main street. The proprietors of motion picture theatres in Boise are not making any money at present and with a city license of \$100 and a war tax of \$100 per annum together with the expenses of operating a theatre, he does not see what will be left for the proprietors.

"The proposition of levying a special tax against exhibitors of motion pictures will simply mean a raise in the admission price is nothing more or less than placing a tax on the poor man's amusement, the poor man's recreation, the joys of his children and to a large extent his education." This is the statement made by J. A. Ludingston, proprietor of the Rex Theatre at 921 Main street. He states that it will mean a raise in price of admissions of the theatres able to pay the tax and will close many down as business has been none too good the past year and with the expenses of the motion picture theatres on the increase, the attendance on the decrease, the business cannot afford to be burdened with further expense.

He'll Let Tax Collector Run the Theatre

"If the special war tax on motion picture theatres goes through as recommended by the Ways and Means Committee and some government agent comes around to collect \$100 from me I will simply hand over the keys to my show house and tell him to stay on the job and run the house and take the \$100 out of the proceeds after paying expenses and there will be one government tax collector who will learn something about the business and how long it takes to get \$100 profit out of the business." This statement was made by Fred N. Tracy, of the Cozy-Tracy Theatre in the Merino building on Main street.

J. N. FLOYD.

Big Cincinnati Exhibitors Show Selfish Indifference

Special to THE MOTION PICTURE NEWS

Cincinnati, Oct. 6.

CINCINNATI exhibitors representing the larger interests in the field seem inclined not to be worried over the proposed war tax of \$100 to be imposed by the Democratic Congress.

Those of them who were interviewed by a representative of THE MOTION PICTURE NEWS took the view that if the tax is levied, it will have to be paid and the exhibitor had best put up his share and be thankful that it is not more. The

amount, \$100, it was pointed out, is only a "drop in the bucket" to the big exhibitor.

One Cincinnati man, who for certain reasons would not be quoted on the subject, declared to a number of fellow exhibitors that he believed the tax would be a good thing for the high class exhibitor. His view was a selfish one.

Would Like to See Small Houses Forced Out

"The owners of the larger houses will not feel the tax," he said, "while the small exhibitor may find it a heavy load. For my part I wouldn't care if the tax were \$500, for then some of these 'poor' exhibitors who are showing five and six reels for five cents and keeping the audiences away from the better houses, would be forced out of business.

"It is this class of exhibitors who have been responsible for making patrons of theatres expect big quantities in pictures and cause them to lose sight of the quality."

E. P. Bernardi, manager of the Colonial Theatre on West Fifth street, said: "Of course I do not mind the tax and will pay it without a murmur if it is levied. *I do not think it is a fair method of taxation, however.*

"If a tax had been placed on every ticket sold *the revenue would have been much greater and the hardship, imposed on the small exhibitor by the present plan, would be eliminated.* If the tickets had been taxed, say one or two cents on each, it would also have given the exhibitors an excuse for raising prices and we could have made the public pay the tax."

"What's the Use of Objecting?"—Hennegan

Joseph Hennegan, manager of the Lubin, said: "I do not mind the tax. Motion picture theatres are subject to those things and I guess we will have to pay. What's the use of objecting? We cannot put up our price for we haven't the line of goods that the grocer or butcher or baker has."

Charles Weigel, manager of the Alhambra, took a different view. He said: "The motion picture theatre is not a luxury. It is a necessity. The Government evidently has not realized this in contemplating the tax of \$100 for war purposes.

"*Exhibitors should no more be taxed than should newspapers, for they are just as important in the lives of the people in any community.* I am opposed to paying a tax of this sort, however little I may feel it, because I do not think it is fair, either to the exhibitors or to the people who patronize our theatres.

ROE S. EASTMAN.

EXCHANGE MAN WANTS ALL WAR FILMS PROPERLY LABELED

Special to THE MOTION PICTURE NEWS.

Minneapolis, Oct. 6.

IN the interests of accuracy and for the future credence of patrons, film manufacturers and exhibitors should unite in the proper labeling and designation of all war films, is the opinion of M. Sansby, manager of the Minneapolis office of the Ramo company.

"When the pictures of the war really come to us we don't want the patrons saying, 'Oh, that film was made in New Jersey or New York,'" said Mr. Sansby. "We know the trouble newspapers have with scoffers, even when they do their utmost to get authentic news, and we want to keep scoffing and doubt away from our news films, if possible."

The Ramo company is doing an excellent fall business.

FAVORS FIRE DRILLS IN SYRACUSE THEATRES

Special to THE MOTION PICTURE NEWS

Syracuse, Oct. 7.

THERE has been some sentiment aroused in behalf of fire drills in Syracuse motion picture houses, with the result that the matter received serious consideration at the hands of the Commissioner of Public Safety.

The Commissioner has announced that he believes such an idea very impractical and stated that no further consideration would be given the question.

"I am in favor," said the commissioner, "of having every theatre employee given definite duties to perform in the event of fire or panic, and I believe fire drills would be a proper thing among employees only."

Dyreda Producing Important Pictures

Company, Just in the Field, Headed by Frank L. Dyer, J. Searle Dawley and J. Parker Read, Jr.—First Production, "One of Millions," Stars Laura Sawyer and Robert Broderick—Studio at Yonkers, N. Y., on Clara Morris Estate

THE latest important company to appear in the film field is the Dyreda Art Film Corporation. The officers of the concern are men who have gained considerable reputation in the trade. They are:

Frank L. Dyer, J. Searle Dawley and J. Parker Read, Jr. Formerly Mr. Dyer was the president of the General Film Company. Mr. Dawley was at one time associated with the Edison and Famous Players companies. Mr. Read is known as a successful producer and exploiter of independent special features.

Before assuming the presidency of the General Film Company, Frank L. Dyer was for quite a while the president of Thomas A. Edison, Inc., of Orange, N. J. He was the active head of all the manufacturing companies during this incumbency. Mr. Dyer is by profession a lawyer, and while with the General Film Company made a name for administrative ability

among exhibitors and all others coming in contact with him.

J. Searle Dawley became associated with the Edison company as a director in May, 1907. Previous to this he had been in stock for five years in Brooklyn, N. Y., where, in addition to his acting, he wrote eighteen plays, all of which were produced.

While with the Edison company Mr. Dawley added to his laurels, particularly when he put on "The Charge of the Light Brigade." Of this single reel 309 prints were sold in England alone. In June, 1913, Mr. Dawley became associated with the Famous Players. The work he did for that company is well known throughout the country.

The Dyreda Art Film Corporation has already produced one subject, "One of Millions." This is a story of the present hostilities in Europe. But the treatment deals with the domestic phase of the war's effects rather than with the actual fighting.

It is a three-reel subject, starring Laura Sawyer and Robert Broderick. Miss Sawyer is well known in screen circles. For some time she was with Edison and later played in Famous Players dramas.

Mr. Broderick has also been seen in

Famous Players productions, receiving many favorable comments on his acting. He is noted for his work with Pathé and with Kalem.

The Dyreda company has engaged four other players of experience.

A second subject, entitled "In the Name of the Prince of Peace," is now being produced at the studio of the company in Yonkers, N. Y. The plant, erected on the Clara Morris estate for the Reliance company under the supervision of David W. Griffith, has been leased from the Mutual Film Corporation.

Although offers have been made by four distributing companies, the Dyreda corporation has not yet closed any contracts. This matter will not be decided in a hurry, as the company is anxious to look the field over carefully before making a final choice of a releasing company.

Mr. Read said recently that negotiations were on with one of the largest theatrical producers to film his successful drama with the original stars appearing in the screen roles.

The following are the officers of the Dyreda company: President, Frank L.

Dyer; vice-president and general manager, J. Parker Read, Jr.; treasurer, J. F. Redfield, formerly assistant treasurer and assistant secretary of the General Film Company. The activity of the Dyreda offices has brought the plans of the company to maturity. An important announcement is forthcoming and will be made in the following issue.

Mr. Dawley will

look after the producing end of the company's affairs and will spend probably all his time at the studio. His supervision guarantees the pictures' quality.

THE MOVING SPIRITS OF THE DYREDA CORPORATION



J. PARKER READ, JR.

J. SEARLE DAWLEY

FRANK L. DYER

"In the Name of the Prince of Peace" will be in four or five reels. Like "One of Millions," it was written by Mr. Dawley, who is responsible for the direction of both productions. The picture is being filmed on two large stages. One is a glass enclosure measuring 100 x 60 feet. The other, outdoors, is 130 x 100 feet.

In one scene, the producer is using an interior the company considers as having a greater depth than any other in the country, 130 feet.

The second picture has a background of the European war, but care has been taken not to wound the feelings of sympathizers of the warring nations. Action obtained by the introduction of battle scenes is not neglected, and they are being staged in such a manner that they create atmosphere. A battery of fifty men, comprising a detail of the N. G. N. Y., comprising a detail of fifty men, took part in some of the battle scenes.

The way in which the members of the various departments of the studio are responding to the demands put upon them has called forth the commendations of Mr. Dawley.

At the head of the camera department is Irving Willat. Robert Nicholls is in charge of the stage carpentry.

MINISTER DEFENDS MOTION PICTURES

Special to THE MOTION PICTURE NEWS

Trenton, N. J., Oct. 7.

The Trenton Inter-Church Federation has requested the city commissioners to appoint a board of five members to censor vaudeville, burlesque and other theatrical productions.

However, in making the request, the Rev. Guy L. Brown, chairman of the Purity Committee of the Federation, said that the churchmen did not consider it necessary to censor the motion pictures shown here. Therefore, the motion picture houses were given an endorsement, but at the same time the vaudeville attractions came in for some criticism.

However, it is the general opinion of the commissioners that such a board would be worthless, as it would be without power to take action, and would result in the giving of wide publicity, possibly, to shows which the body might criticize.

MABEL NORMAND TAKES A VACATION

Mabel Normand, known all over film-dom as "Keystone Mabel," has "dropped everything," as it were, at the New York Motion Picture Company's plant



MABEL NORMAND

on the West coast, and is in the East on a vacation. New York is the pretty comedienne's first "port of call." Miss Normand cannot rest long—it isn't her temperament—but while she is in the East, she will make the most of her "playtime."

"PAULINE" IN SONG

"The Perils of Pauline," the successful Eclectic serial, is celebrated in a song called "Poor Pauline," which is achieving remarkable popularity. The St. Louis "Republic" of September 22 states that Louis Allen while rendering this song from the stage, fell into the orchestra in his attempts to imitate Pauline in her various stunts.

STATE INSTITUTIONS TAKE MOTIOGRAPHS

The John Biegger Company, of Sioux Falls, S. D., have just installed the latest model motiographs, the product of the Enterprise Optical Manufacturing Company, of Chicago, in the South Dakota Industrial School, at Plankinton; the South Dakota Penitentiary, at Sioux Falls; and the State Asylum, at Yankton, S. D.

**HAVE YOU \$100
To Throw Away?
SEE PAGE 17**

Film Magnates at Mastbaum Dinner

(Continued from page 26.)

less connected with various amusement enterprises, but is now mainly interested in developing the Stanley chain of theatres along legitimate business lines.

Carl H. Pierce spoke, and gave a resume of what has been accomplished already by the newspapers in various parts of the country. Mr. Pierce spoke of the relationship between the motion picture industry and the press.

After reviewing the birth and growth of the industry to the present time, giving due credit to Mr. Lubin, Mr. Zukor, Mr. Lasky, Mr. Bosworth and other prominent manufacturers, Mr. Pierce, after dwelling upon the benefit to the trade of such a distributing system as the Paramount Plan, traced the history of the establishment of motion picture departments in the leading newspapers of the country, giving credit to THE MOTION PICTURE NEWS for valuable information concerning the success of such papers as the Seattle "Times," the Baltimore "News," the Philadelphia Evening "Telegraph," and others.

After making it plain that motion picture departments have paid and are paying dividends to their papers, Mr. Pierce said:

"Without systematic, liberal, progressive, steady advertising, no playhouse, no exchange, and no manufacturer can expect to do business today. The tendency is to advertise spasmodically, sparingly, unintelligently, and I assume that it is the duty of the press to educate the advertiser along these lines."

Banquet Marks Era in Industry.

The souvenirs at the banquet were small bisque figures placed at each plate, and the menus were handsomely decorated, and the back contained a list of the invited guests, each man being given his particular nickname.

This banquet is but the beginning of a new era in the motion picture industry, because it is shown that the newspapers, trade papers, the exchange men, exhibitors and producers are all working to reach a common end.

J. M. SOLOMON, JR.

Horsley Offers \$250 for Brand Name

President of Centaur Company Will Pay Cash Prize for Title to Take Place of Ace Brand—Contest Will Close at Noon, October 24

THE announcement made last week that David Horsley's products are to be released through the General Film Company has aroused great interest and caused widespread comment in film circles.

Letters and telegrams have been pouring into Mr. Horsley's office by the hundreds. Almost every one of these communications carried suggestions of a brand name for the new releases, while several expressed an objection to the tentatively adopted name of Ace.

As a result Mr. Horsley has decided to withdraw the brand name of Ace and to choose the new title by open competition.

Accordingly, Mr. Horsley has offered a cash prize of \$250 to the person who shall suggest the most appropriate name, and has thrown the competition open to anyone who is in any way connected with the motion picture industry.

This includes exchange men, exhibitors, scenario writers, directors, actors, the trade press, accessory manufacturers and all employees of manufacturers or film concerns, whether in the studio, factory or office.

The selection of the name from the list submitted will be left to a committee of disinterested judges. Three of the best known film men in America have been invited to act in this capacity, and have already signified their willingness to accept.

Announcement of their names will be made in the next issue of THE MOTION PICTURE NEWS.

Owing to the great number of answers which will undoubtedly be received, and the exceedingly short time in which Mr. Horsley must necessarily select a brand name, each competitor will be limited to one suggestion.

Competitors are required to explain the significance or reasons for their suggestions in a letter which must not exceed fifty words, and the competition will positively close at noon on Saturday, October 24.



MARY PICKFORD IN "SUCH A LITTLE QUEEN" (Famous Players)



DAVID HORSLEY announces a Prize Competition for the selection of a new brand name for the comedies and dramas of his manufacture to be released on the regular program of the General Film Company.

\$250.00 will be paid to the winner.

THE JUDGES will be disinterested film men of unquestionable standing. Competitors must be in some way connected with the cinematographic art and will be allowed one suggestion each, which must be explained in a letter, not over 50 words in length. Competition closes Saturday, October 24th, at noon. *Address Advertising Department.*

— **DAVID HORSLEY** —
CENTAUR FILM Co. — BAYONNE, N.J.

INTERESTING FILM REVIEWS

PRODUCTIONS FROM ALL PROGRAMS

GENERAL FILM PROGRAM

"The Heart of Sonny Jim." (Vitagraph. Wed., Sept. 30.)—Sonny Jim sells Toto, his beloved dog, in order to get money to buy a bracelet to make up for one his mother had lost. His father and mother learn of it and there is a new bracelet which Sonny supposes he supplied the money for. The loss of his dog proves too much for him to bear, but eventually he gets it back. Well acted by a cast including Bobby Connelley, Tefft Johnson, Mabel Kelly, William Dunn and George Stevens.

"The Ex-Convict." (Kalem. Wed., Sept. 30.)—Occupies about a reel and a half, being completed by an industrial showing the manufacture of implements of warfare. It is a strong and well acted drama of present day life which presents a plausible story.

"Food for the Dogs of War." (Kalem. Wed., Sept. 30.)—On the same reel with part two of "The Ex-Convict." It is an interesting and timely industrial showing the manufacture of arms and ammunition.

"His Brother Bill." (Lubin. Two reels. Wed., Sept. 30.)—A Civil War story. A Confederate sharpshooter kills one of two brothers in the Federal army. Later he makes friends with the dead man's brother who is trying to kill him in revenge. After the war he goes home and takes the dead brother's place in the family. Finally he marries the Northerner's sister. Entertaining but improbable. The cast is headed by John Ince, Charles Kelly and Harry Lane.

"The Love of Pierre Lacrosse." (Vitagraph. Thurs., Oct. 1.)—A story of a lover whose love is so deep that he gives his life in order that the girl he loves may marry his rival. The characters are French Canadians. James Morrison and Dorothy Kelly play the leading parts.

"The Spirit of Jealousy." (Biograph. Thurs., Oct. 1.)—A melodrama pointing the moral that jealousy brings trouble. The story is overdone, and therefore lacking in force.

"His First Case." (Lubin. Two reels. Thurs., Oct. 1.)—A story of much interest is presented in this film. The chief fault is that it is not very true to life, and does not present a course of action which a man under the same circumstances as the hero would be at all likely to follow.

"Eats." (Vitagraph. Fri., Oct. 2.)—Two tramps feel the need of food. By using a stolen policeman's uniform they get some, but they are discovered and landed in jail. Billy Quirk and Lee Beggs play the tramps.

"The Peasant's Lie." (Biograph. Fri., Oct. 2.)—This is a drama of the poor man who accepts a bribe to put a country girl in a position where she cannot see her lover. The rich man thus expects to be able to win her, but he is disappointed, and his own plans prove his undoing. A fairly interesting story.

"The Royal Wild West." (Vitagraph. Two reels. Sat., Oct. 3.)—This is a rather good comedy, which combines a burlesque on Wild West pictures and on English customs. Some young Englishmen of aristocratic tastes try to produce Wild West pictures in England. The result is so remarkable that it finds a ready sale as a comic.

"On Circus Day." (Lubin. Sat., Oct. 3.)—This is a lively comedy, which makes good use of the situation stated in its title. The story is improbable, but interesting.

"The New Roads Mascot." (Biograph. Sat., Oct. 3.)—The old story of a man who commits a crime because of the good which he hopes will come from it, but instead is met by a wholly unexpected and great misfortune as a direct result of his act.

"Fisherman Kate." (Vitagraph. Mon., Oct. 3.)—A fairly entertaining comedy of a fishing trip on Friday the 13. Kate has a bad day, finally being pulled overboard by a four-inch fish. Kate Price is featured.

"The Borrowed Book." (Biograph. Mon., Oct. 3.)—A rather unimpressive drama, which is acted better than it is produced. The story is a familiar one.

"His Unknown Girl." (Vitagraph. Two reels. Tues., Oct. 6.)—This is a war story in which a superior officer being jealous of a man lower in rank, adopts the tactics of David with Uriah. He meets with less success, however, as he is killed and the girl's true lover wins her. The principals are Darwin Karr, Gladden James and Naomi Childers.

"Wife's Athletic Mamma." (Lubin. Tues., Oct. 6.)—On the same reel with "A Hunting Absurdity." It is a comedy dealing with the mother-in-law idea.

"A Hunting Absurdity." (Lubin. Tues., Oct. 6.)—On the same reel with "Wife's Athletic Mamma." It is an entertaining comedy.

"George Washington Jones." (Edison. Split reel. Mon., Oct. 12.)—Uproarious comedy of the darkey frightened out of his wits and almost out of his skin by ghosts. George Washington Jones has had luck and he goes to a hypnotist who professes to be able to cure such fits. He makes George "see something in white," and George takes to his heels. He sees the street cleaner and runs, the baker and runs, the candlestick-maker and runs, even into the arms of his wife in her nightie, and runs again, into the meal bin. On the same reel with "Buster Brown's Education."

**HAVE YOU \$100
To Throw Away?
SEE PAGE 17**

"Buster Brown's Education." (Edison. Split reel. Mon., Oct. 12.)—The popular hero and children's delight and his sister, Mary Jane, have great sport with the tutors which their mother engages for them. Tige does his part, and when the tutor gets the best of the dog, the goat comes in manfully and butts just as genuine goats act. On the same reel with "George Washington Jones."

"Percy Pimpernickel, Soubrette." (Kalem. Tues., Oct. 13.)—Supposed to take place in the year 1950, this film is a good burlesque on where-is-my-wandering-boy-tonight school of melodrama. Betty Teare, John Brennan, Carrie Ward and W. H. Brown are the principals.

"Seed and Harvest." (Kalem. Wed., Oct. 14.)—Fred and his mother are weak-willed and hamper Dan, Fred's brother, in his career. Ida, a strong-minded girl who loves him, saves Dan from his family, and the mother sets about the regeneration of Fred. In the cast are Alice Hollister, Robert Walker, Harry Millarde and Helen Lindroth.

"Andy and the Redskins." (Edison. Wed., Oct. 14.)—That delightful little comedian, Andy, takes it into his head that he would like to hunt Indians, rescue a poor, helpless girl from the savages, and be proclaimed far and near a hero. He gets an outfit, but instead of taking a train for the West, he goes into a Wild West show nearby and makes friends with the Indians and the cowboys. There his mother finds him, gives him a spanking and pulls him home.

"From Peril to Peril." (Kalem. One reel. Sat., Oct. 17.)—The name of this pic-

ture might well be applied to the experiences of the cast which produced it. Their adventures are as thrilling as is usual in a picture produced by J. P. McGowan. Helen Holmes is featured, supported by G. A. Williams, Charles Wells, J. P. McGowan and Bert Hadley. Helen is caught by yeggs who are robbing her father's safe. She manages to give the alarm to her sweetheart, and the thieves escape on a freight. The young people pursue them in a motorcycle, and overtake them when the train is halted by a lift bridge. The crooks try to run across the bridge while the trainmen are looking for them. Helen lifts the bridge and then jumps into the water after them. They are caught. The scenes on and around the bridge are thrilling, Miss Holmes' dive from the rising bridge being particularly noteworthy. The race on the motorcycle is also entertaining.

"The Man in the Dark." (Edison. Tues., Oct. 20.)—An old tramp in a Bowery hotel tells the story of his life, and shows that his terrible failure and his unhappiness are due to his refusal to read a note sent to him by his sweetheart after they had quarreled. A pathetic story.

"The Lynbrook Tragedy." (Kalem. Two reels. Mon., Oct. 26.)—A siren actress ruins a man's life and wrecks his wife's happiness. She almost ensnares the fiance of the same man's daughter, but the trouble is avoided. Improbable, but rather well done. Alice Joyce and Tom Moore are featured.

"The No-account Count." (Kalem. Tues., Oct. 27.)—The old story of a nobleman whose clothes are stolen by a tramp who impersonates him. There is some fun, but much lack of originality. In the cast are John Brennan, Frederick Hornby, John Rand and Ethel Teare.

"The Menace of Fate." (Kalem. Two reels. Wed., Oct. 28.)—A girl is kidnapped and brought up as a thief. She is rescued just before she gives in completely to her environment. Alice Hollister and Harry Millarde head the cast. Depressing in spots, but a good picture.

"Ham and the Villain Factory." (Kalem. Fri., Oct. 30.)—A burlesque which is really funny, although the story it tells is the familiar one of a broken-down auto and a rival's carriage. Ruth Boland and Marshal Neilan head the cast.

"The Vengeance of Winona." (Kalem. Sat., Oct. 31.)—An Indian story which is interesting, though without a plot. Mona Darkfeather is featured.

UNIVERSAL PROGRAM

"The Futility of Revenge." (Imp. Two reels. Thurs., Oct. 15.)—This picture portrays all that the title conveys in a very absorbing story. Alexander Gade, Dorothy Phillips and Howard Crampton hold the leading parts.

"The Close Call." (Sterling. Mon., Oct. 12.)—A child named Felix assumes Billy's role in this juvenile comedy, but he isn't as good as his more noted predecessor. But he rescues Olive from the side of a cliff where she has fallen, and his act and the whole picture is very amusing.

"Cupid, Victor." (Eclair. Sun., Oct. 11.)—A fantastical and pleasant offering in which Ann Mansfield, a child actress, performs remarkably well. Mildred Bright and Stanley Walpole are the leads. The young man, who has persistently courted an artist, is finally accepted, but only after the woman's heart has been moved by the instigation of Cupid, a statue which she modeled, and which became alive in her dreams.

WENT OVER WITH A BANG!

**\$28,000 IN RENTAL OFFERS RECEIVED WITHIN
18 HOURS AFTER FIRST SHOWING**

Electrified its brilliant premiere audience at the Maxine Elliott Theatre, New York, last Thursday evening.

B. F. MOSS FILM PRODUCTION

IN FIVE REELS

OF

**THE MOST UNIVERSALLY POPULAR NOVEL OF THE
CENTURY—ELINOR GLYN'S IMPERISHABLE ROMANCE**

(Only authorized version)

(All infringements prosecuted)

An adaptation that delights all and offends none



**A SURE BOX OFFICE BONANZA!
ADVENTUROUS!! EXCITING!! THRILLING!!**

Declared a striking novelty by all photoplay critics. See how this week's reviewers sing its praises. A fascinating love drama of a young king without a country and a queen without a throne.

70,000,000 have read this book. Seven times that number will want to see the photoplay.

A \$50,000 PRODUCTION—280 SCENES

For booking United States, Canada and European rental and states rights offers invited.

ADDRESS ALL COMMUNICATIONS TO

RELIABLE FEATURE FILM CORPORATION

B. S. MOSS, President

701 SEVENTH AVENUE, NEW YORK CITY

JESSE L. LASKY

presents

for the Second Paramount Quarter

The following eloquently magnificent
array of known successes and star players

DECEMBER

- 7th—*The Ghost Breaker* with *H. B. Warner*
 14th—*The Man From Home* in asso. with Liebler Co. with *Charles Richman*
 24th—*Cameo Kirby* in asso. with Liebler Co. with *Dustin Farnum*

JANUARY

- 4th—*The Governor's Lady* in asso. with David Belasco *All-Belasco Cast*
 11th—*The Girl of The Golden West* in asso. with David Belasco *All-Belasco Cast*
 21st—*The Goose Girl* Star announced later
 28th—*Merely Mary Ann* in asso. with Liebler Co. Star announced later

FEBRUARY

- 15th—*Warrens of Virginia* in asso. with David Belasco Star announced later
 18th—*The Country Boy* *Special all-star cast of players*

MARCH

- 1st—*The Woman* in asso. with David Belasco Star announced later

All produced on the universally recognized LASKY
standard of artistic excellence

JESSE L. LASKY

LONG ACRE THEATRE

JESSE L. LASKY
President

SAMUEL
Treas. &

Basing Nothing On Promises
Announcement of What Has Gone Before
and What is to Come on the
FIRST PARAMOUNT QUARTER

Reveals a continued desire to achieve a goal of artistry and productive thoroughness heretofore not attempted by any producer.

SEPTEMBER

- 7th—*The Virginian* with *Dustin Farnum* (Now Playing)
17th—*Making of Bobby Burnit* with *Edward Abeles* (Now Playing)

OCTOBER

- 12th—*Where The Trail Divides* with *Robert Edeson*
22d —*What's His Name* with *Max Figman*

NOVEMBER

- 5th—*Ready Money* with *Edward Abeles*
16th—*Rose of The Rancho* in asso. with *David Belasco* with *Bessie Barriscale*
and BELASCO CAST
19th—*The Ringmaster* with *Theodore Roberts*

Original Policy of One Production a Month, relegated to the discard by popular public demand which now calls for thirty LASKY productions during the forthcoming Paramount Year.

FEATURE
PLAY **COMPANY**
NEW YORK CITY

GOLDFISH
Gen'l Mgr.

CECIL B. De MILLE
Director General

Exchange Men Form \$1,000,000 Combine

Twenty-five Is Present Membership of New "Standard Program," Details of Which Were Consummated in Indianapolis October 1 and 2—Twenty-one Reels a Week Subscribed to by Each Member—Releases Begin December 1—Offices Will Open Soon

A SECRET meeting of representative exchange men from all parts of the United States and Canada in Indianapolis on October 1 and 2 resulted in the launching of a strong combination which will distribute and rent what will be called the Standard Program. The forming of a million-dollar corporation under the laws of the State of New York was determined upon and general plans for the execution of the organization's project will be actively begun at once.

Twenty-one reels a week comprise the company's first output, which will be increased to meet demands.

Rumors of such a consolidation have long been in the wind, but such was the secrecy with which the plan was matured that not until several exchange-men came East and arrived in New York following the Indianapolis meeting, that particulars were learned.

The following cities were represented at the meeting: New York, Philadelphia, Atlanta, Pittsburgh, Cleveland, Detroit, Cincinnati, Indianapolis, Chicago, Milwaukee, Minneapolis, Buffalo, St. Louis, New Orleans, Dallas, Portland, San Francisco and Los Angeles. Letters were read from most of the exchange-men in the cities not represented, all of which expressed themselves emphatically favorable to the plan. Joseph Hopp, of Chicago, presided as chairman of the meeting. E. T. Peter, of Dallas, acted as secretary.

Markowitch, of California, Sam Werner, of St. Louis, and Mr. Peter were appointed a committee to draft an agreement which was signed by everyone present.

Twenty-five Exchanges Banded

To band together twenty-five exchange men operating in the United States and Canada is the purpose of the company,

CLASSIFIED

FOR SALE

LARGE FEATURE EXCHANGE closing business. No reasonable offer refused on office fixtures, features, commercials, safe. ROOM 812, 71 WEST 23d ST.

and this is practically consummated. Each member had to agree to buy twenty-one reels of film each week and pay for this film in proportion to the quality of the individual production.

The basic idea generally expressed was that they did not want manufacturers to ship them film on a percentage basis, because, under those conditions they were forced to take what was sent, regardless of quality.

Also, they are equally determined upon not buying film at set price of so

**HAVE YOU \$100
To Throw Away?
SEE PAGE 17**

much a foot, as under these conditions the quality of the program would not improve because of the lack of incentive on the part of manufacturers to raise their standards.

The members absolutely believe that there are sufficient number of high-class manufacturers in the United States today to make the Standard Program a new standard of merit. It was stated at the meeting, in substantiation of this, that already good film had been offered to them sufficient to release thirty-four reels weekly instead of twenty-one reels, which, however, will be the initial number.

Begin Releases December

December 1 is the approximate date of the first release. Its exact nature is not announced. As now planned, however, the program weekly will consist of two three-reel subjects, three two-reel subjects, and nine single reels. Seven of the latter will be comedies.

Territories will not be divided by State lines, but to facilitate the shipping arrangements of each office with the purpose of giving the most efficient service to the exhibitors.

The board of directors will be selected from exchange men. E. T. Peter, president of the Texas Film Corporation, will probably be in charge of head-

quarters in New York. Large offices to handle a large business will quickly be opened.

FILM MANUFACTURERS JOIN THEATRICAL ASSOCIATION

A number of motion picture manufacturers have been elected to membership on the board of directors of the United Managers' Protective Association.

The men who will serve on the board are as follows:

J. Stuart Blackton, vice-president of the Vitagraph Company; P. J. Kennedy, president of the Biograph Company; Adolph Zukor, president of the Famous Players Film Company; P. A. Powers, president of Warner's Features; Harry R. Raver, president of the All Star Feature Corporation; C. H. Wilson, vice-president of Thomas A. Edison, Inc.; Jesse L. Lasky, of the Jesse L. Lasky Feature Play Company; William N. Selig, of the Selig Polyscope Company; Siegmund Lubin, George Kleine, Carl Laemmle, of the Universal Film Manufacturing Company, and Samuel Long, of Kalem.

The United Managers' Protective Association was recently formed for the purpose of combating adverse legislation affecting the rights of the theatrical profession, and will not only watch bills at Washington, D. C., but keep informed of the activities of state legislatures through local branches, which will be organized with as much despatch as possible.

All matters of general interest affecting amusement enterprises will receive the close attention of the association. In addition to watching proposed legislation bearing on amusements, the organization will put forth efforts to prevent and adjust labor troubles, and in every manner endeavor to remedy existing evils and promote the future of the business.

The members of the motion picture board are also members of the general board of directors, the motion picture committee being named from the board of directors of the United Managers' Protective Association.

The motion picture manufacturers realized that on account of the numerous problems confronting the industry some action of wide scope was necessary, and they feel that results can be accomplished more quickly at present by allying themselves with the United Managers Protective Association.

Through their efforts the way will be blazed for the exhibitors association to take up matters for the benefit of its members with greater chances of solving the problems now affecting the motion picture industry, it is said.

**ANIMATED
SONGS**

NOTHING MECHANICAL

NO PHONOGRAPH RECORDS

**MOTION PICTURES THAT MOVE TO THE
RHYTHM OF SONG**

IMPERIAL MOTION PICTURE CO. OF NEW YORK, Inc., 1476 Broadway

The Year's Greatest Success

KELCEY AND SHANNON

IN

AFTER THE BALL

Taken from Chas. K. Harris' World's Greatest Song
 Pictured and Produced by Pierce Kingsley

WHAT MANAGERS SAY:

Eastern Theatre Managers' Association,
 Chas. W. Boyer, Secretary.
 Hagerstown, Md., Sept. 25, 1914.
 Photo Drama Co.,
 Candler Building, New York City.
 Gentlemen: I want to say this regarding the picture, AFTER THE BALL—it was a big hit, and notwithstanding a heavy rain turned people away the night I played it. I also want to go upon record as saying that in every respect it is the best handled feature I have ever played. The posters are varied and beautiful, the big eight-sheets (type) very showy. The heralds fine, the frame of photos the finest I have ever used, the slides pretty.
 Yours very truly,
 (Signed) CHAS. W. BOYER.

Lyceum Theatre,
 Elmira, N. Y., Oct. 3, 1914.
 Photo Drama Co.,
 No. 220 West 42d St., N. Y. City.
 Gentlemen: Just a word to congratulate you on the excellent picture you sent me this time. I refer to the HERBERT KELCEY and EFFIE SHANNON in AFTER THE BALL. It was very clear and a beautiful piece of work. It is the kind of picture to get the money.
 With best wishes, I remain,
 Very truly yours,
 (Signed) LEE NORTON.

Fine and Kramer,
 Amusement Enterprises,
 Meadville, Pa., Oct. 5, 1914.
 The Photo Drama Co.,
 220 West 42d St., New York City.
 Gentlemen: Want to say that AFTER THE BALL picture gave excellent satisfaction to our patrons. Personally we can recommend the feature very highly and would like to play a return date for same.
 Respectfully yours,
 (Signed) FINE AND KRAMER,
 Per M. S. F.

Samuels Opera House,
 Jamestown, N. Y., Oct. 3, 1914.
 Photo Drama Co.,
 220 W. 42d St., New York City.
 Gentlemen: AFTER THE BALL. I wish to state that this feature with HERBERT KELCEY and EFFIE SHANNON gave entire satisfaction to all of those who had the pleasure of seeing it in my theatre.
 If you have any more features on a standard with AFTER THE BALL I will be very glad to give you a date in Jamestown.
 Very truly yours,
 (Signed) ED. CONNELLY, Gen. Mgr.

Hippodrome Theatre,
 64 Ford St.
 Ogdensburg, N. Y., Sept. 25, 1914.
 Photo Drama Co.,
 220 W. 42d St., New York City.
 Gentlemen: I desire to say that the feature AFTER THE BALL was the best ever shown in this theatre. We ran it two days, and played to over capacity



houses, many going away without even seeing it at both days of exhibition on account of we not even having standing room.
 I can say that any theatre who will book and bill this feature need not worry about the house being filled for two or three days—don't matter as to the weather.
 Very truly,
 (Signed) HIPPODROME THEATRE,
 W. B. Steenberge, Mgr.

The Baker Theatre,
 Dover, N. J., Oct. 3, 1914.
 Photo Drama Co., Inc.,
 Candler Building, New York City.
 Gentlemen: Congratulations are surely due to you for your wonderful screen production, AFTER THE BALL.
 AFTER THE BALL was projected at this theatre Saturday matinee and evening, September 26, and, in point of numbers, established a new record, and the writer can heartily recommend its sterling qualifications to all lovers of pure picture drama.
 Respectfully yours,
 (Signed) R. F. WOODHULL, Mgr.

Weiting Opera House,
 Syracuse, N. Y., Oct. 5, 1914.
 The Photo Drama Co.,
 220 West 42d St., New York City.
 Gentlemen: I consider KELCEY and SHANNON in AFTER THE BALL the best feature photo-play that this house has ever shown, its drawing power was wonderful, and I would be pleased to have the attraction for a return date.
 Very truly yours,
 (Signed) WIEITING OPERA HOUSE,
 By F. P. Martin, Business Manager.

Bradford Theatre,
 Bradford, Pa., Oct. 3, 1914.
 The Photo Drama Co.,
 New York City, N. Y.
 Gentlemen: On Sept. 9 and 10 of this year I played AFTER THE BALL to very excellent receipts at the above theatre. I am again playing it on this date, Oct. 3, for a special return engagement.
 It is a "Thriller" in many ways, yet is logical withal, and the photography as a whole is certainly very clear, while the entire production from the scenario to the screen shows a master hand all the way through.
 Yours very truly,
 (Signed) BRADFORD THEATRE,
 C. W. Lawford, Manager.

Reis Circuit Co.,
 October 2, 1914.
 The Photo Drama Co.,
 Chandler Building, New York, N. Y.
 Gentlemen: Your feature photo-play of KELCEY and SHANNON in AFTER THE BALL gives me pleasure of recommending it as a first-class feature, and which played to capacity business at Rand's Opera House, Troy, New York.
 Sincerely,
 (Signed) O. H. STACY, Mgr.

WARNING TO ALL MANAGERS The Photo-play Booking Association, 176 N. State St., Chicago, are in no way connected with the Photo Drama Company, and have no right to quote AFTER THE BALL for booking purposes. Managers: send your open time direct to us and we will fill your date from our nearest office.

PHOTO DRAMA COMPANY, Inc.

220 West 42nd Street, New York City, N. Y.

"BILL" STEINER

JIM MAHER

ALL STAR FEATURES

ETHEL BARRYMORE
in **"The Nightingale"**

By Augustus Thomas Five Reels

COMING

DIGBY BELL

in

"The Education of Mr. Pipp"

By Augustus Thomas Five Reels

James A. Herne's
SHORE ACRES

Five Reels

All Star Feature Corp.

220 West 42d Street

New York

HAVE YOU \$100

To Throw Away?

SEE PAGE 17

First Horsley-General Release November 9

Three Comedies a Week Will Be Issued and Probably a Drama in Addition
During the Winter—Horsley Enthusiastic

DAVID HORSLEY has chosen November 9 as the date of the first release of his comedies on the General Film program. The Horsley films will be released three days each week, and probably during the winter a drama will be added to the list.

Mr. Horsley is enthusiastic over the prospect of having his films included on the "G. F." program, and expresses the belief that he will set a high water mark in the number of copies sold.

"I have long been prepared for just this opportunity," said Mr. Horsley when seen at the Centaur studio. "Years ago, when the Biograph was the talk of the film world, I clipped off a little strip of one of their films and promised myself that I would never stop until I had brought my products up to that high photographic standard. I believe I have achieved that great desire, and that the films which I shall offer through the General Film Company will measure up with the finest to be seen on any screen.

"In spite of that, I feel that I am still a mere beginner and a student in an in-

finite art. I am working and thinking as hard today as I ever did, and know that I will go on improving and perfecting as long as I am in the game. Before the winter is out I will slip out something which I now have up my sleeve, and which will mark a distinct advance in motion picture presentation."

"KITTY COBB" PAPER IN SEVEN COLORS

Warner's Features, Inc., which is releasing "The Adventures of Kitty Cobb," the big four-part production of James Montgomery Flagg's famous drawings, is offering a line of Kitty Cobb paper ranging from one-sheets to 24-sheets, with two and three different subjects in each size.

It is said that in the neighborhood of \$20,000 was expended in producing these lithographs. The drawings were all made by Mr. Flagg himself especially for the paper, and the lithographing was done in seven colors on a good quality of stock.

Every exhibitor who has booked "Kitty Cobb" has expressed surprise and gratification at both the quantity and quality of the paper.

Will sell Michigan rights on following features:
"HIAWATHA" "LES MISERABLES"

Will also sell the following films:

"ENOCH ARDEN" "DAVID COPPERFIELD"
"JUDGMENT OF SOLOMAN" "XMAS CAROL"

Must be sold within next thirty days. Write Geo. W. Trendle, Trustee, Estate Benjamin Fay Mills, Bankrupt, 1706 Dime Bank Building, Detroit, Mich.

WYANOAK DISTRIBUTES THROUGH EXCHANGES

Through a mistake in last week's advertisement several customers of the Wyanoak Publishing Company were misled into thinking that their line of lobby photos could be obtained only from that company.

This was a mistake and the Wyanoak company hereby notifies exhibitors that their photos may be obtained through the exchanges as previously announced.

F. R. A. HEAD COMING HERE

R. S. Edmundson, proprietor of the American releases of the Film Releases of America, Ltd., London, has sailed for this country. On his arrival here he will enter into negotiations with several leading American manufacturers to represent them in Great Britain and on the continent.

The offices of the Alco Film Corporation in New York have been rearranged. A fifth floor has been added to their already spacious quarters.

AFTER THE BALL
THE LITTLEST REBEL
SHOULD A WOMAN TELL

Are great box office attractions which need no introduction. Book them now.

Photoplay Productions Releasing Co.
37 S. Wabash Ave. Chicago

**WORLD FILM CORPORATION**

Presents

A Shubert photoplay feature
TOM TERRISS

Re-
leased



Oct.
19

in his solution of Dickens'
"THE MYSTERY OF EDWIN DROOD"

Presents

A SPECIAL RELEASE IN

The Messrs. Shuberts Photoplay
Reproduction of the World-Famous

New York Hippodrome

Stupendous Spectacle

"AMERICA"

In 5 Parts

Arrange Bookings through

WORLD FILM CORPORATION

LEWIS J. SELZNICK, Vice President and Gen. Mgr.

130 West 46th Street, New York City

26 Branches throughout the United States and Canada.



NOTICE

To Exhibitors:

IMAGINE a series of twenty stunning, six-color paintings of the leading moving picture actors and actresses, done by Mr. Coles Phillips. Imagine these wonderful pictures perfectly reproduced in post card size by the finest processes known to modern printing and art paper making. Then, imagine giving them to your patrons entirely free.

But this is not all. Along with the pictures is something even more attractive—and it, too, is free. The drawing power of this feature alone guarantees far more regular attendance by old patrons, and the certain winning of many new ones.

You can not overestimate the high standard and great magnitude of this project. Nothing like it, even on a small scale, has ever been attempted in connection with the moving picture business. Exhibitors successful in obtaining this service will realize quick, substantial profits—not for a day or a week, but for many months.

If you are interested you must write us immediately for particulars.

COLES PHILLIPS CO., Inc.
798 Tenth Ave., New York City



“Flying A” Feature Films *American “Beauty” Films*

“DAYLIGHT”
In Two Parts.
Featuring ED COXEN and WINNIFRED GREENWOOD.
Under direction of Thos. Ricketts. Release Monday, Oct. 19th, 1914.

AMERICAN BEAUTY FILMS
“DAD AND THE GIRLS”
A refined comedy in which father unwittingly is caught with the goods.
Release Tuesday, Oct. 20th, 1914.

FLYING “A” FEATURES

“IN THE OPEN”
A thrilling Mexican Adventure. Under direction of Sydney Ayres. Release Wednesday, Oct. 21, 1914.



“THE FINAL IMPULSE”
A Construction Camp Episode. Under direction of Thos. Ricketts. Release Friday, Oct. 23, 1914.

Distributed exclusively through the United States and Canada by the Mutual Film Corporation.

AMERICAN FILM MANUFACTURING CO.
CHICAGO

ALLIANCE PROGRAM POSITIVELY ANNOUNCING

THE GREAT FAVORITE

"The Key to

From the Book by

WITH CARLYLE BLACKWELL,

WILL ABSOLUTELY

THE ALLIAN

and will be shown in Hammerstein's Beautiful

"THE PATH FORBIDDEN"

Released Oct. 19, *Positively*

Produced by the Excelsior Feature Film Co. in five reels. A superb production from the book by John B. Hymer, featuring

OCTAVIA HANDWORTH

"McVEAGH OF THE SOUTH SEAS"

Released Nov. 2

A smashing sensation, being a true story of the South Seas, from the book by H. D. Carey. The most wonderful ocean picture ever produced. A story of daring and action, abounding in strong situations. In five reels, by the Progressive Motion Picture Co., featuring Harry Carey.

BE KNOWN BY THE COMPANY YOU KEEP

The Exchanges handling the Alliance Program comprise the most reliable renters in America, making it the most powerful distributing channel in the world. Pending publication of complete list, exhibitors desiring service can have the name of the exchange handling their territory by writing or wiring us.



ALLIANCE FILMS CORPORATION

TIVE CEMENT

PLAYERS PRODUCTION

Yesterday"

Chas. Neville Buck

AS THE PRINCIPAL ACTOR
BE RELEASED IN

CE PROGRAM

Opera House, New York, beginning October 12th

"AT THE OLD CROSS ROADS"

Released Oct. 26, *Positively*

Picturization of Arthur C. Aiston's famous play, which had a successful run for fourteen years. The leading part is played by

MISS ESTHA WILLIAMS

who starred in the original production.

COMING PRODUCTIONS

THE MAN WHO COULD NOT LOSE, from the book by Richard Harding Davis.

THE SHADOW, from the book by John B. Hymer.

AN UNFINISHED STORY, from the book by Richard Harding Davis.

THE POLICY OF THE ALLIANCE

Means an absolutely square deal to manufacturer, exchange and exhibitor. We do not expect an exhibitor to take a lot of mediocre films for the privilege of getting the good ones. Each manufacturer must hit a bull's-eye with his productions, and must stand by himself.

LEAVITT BLDG.
11th FLOOR

126 W. 46th St., N. Y. City



**ALLIANCE
PROGRAM**

"THE KEY TO YESTERDAY"



Released October 12.

An extraordinary feature dramatized from the book by Charles Neville Buck, in four parts, featuring

CARLYLE BLACKWELL

in the leading role, supported by J. Francis Dillon, Miss Edna Mayo, John J. Sheehan, John Prescott, Gypsy Abbott, and one hundred more.

This film has been pronounced by critics one of the greatest subjects ever produced, and will have its first run in New York City at

Hammerstein's Beautiful Opera House

the week of October 12.

FAVORITE PLAYERS FILM CO., Inc.

M. H. BLACKWELL, Treas.

110 W. 40th St.
Suite 1002
NEW YORK CITY



**ALLIANCE
PROGRAM**

"THE PATH FORBIDDEN"



Released October 19.

Five reels of thrills, sensations and surprises. An up-to-the-minute production with a strong moral tone, pictured from John B. Hymer's book, with

Octavia Handworth

the popular star, in the leading role. Exquisite photography, marvelous trick work and effects and a large, well balanced cast make this film one of the greatest ever produced.

EXCELSIOR FEATURE FILM CO., Inc.

110 W. 40th St., Suite 1002
New York City

HARRY HANDWORTH,
Pres.
ARTHUR ROSENBACH,
Sales Mgr.
WM. H. WRIGHT, Treas.





"AT THE OLD CROSS ROADS"

Released October 26, in Five Reels, Featuring
MISS ESTHA WILLIAMS

in her original role of Parepa, supported by Mrs. Stuart Robson
 Arthur Morrison, Miss Rae Ford, Master Martin, and a large cast.

This play was sent out for fourteen consecutive seasons by Arthur C. Aiston, covering every state in the Union, and has repeatedly broken box office receipts in high class legitimate theatres. It is probably the best known play in America, and its tremendous heart appeal is thoroughly known.

MANY BIG SCENES

The Burning of the Bridge. The Uprising of the Blacks and the Ensuing Battle.
 The Battle at the Old Cross Roads. The Sensational Court Room Scene.

Scenario by Frank L. Dear. Produced by Mr. Dear.

SELECT FEATURE PHOTOPLAY COMPANY, Inc.

S. G. LINDEMAN, Treasurer

71 West 23rd Street

NEW YORK CITY



"ENGLAND EXPECTS——"

(Cosmofotofilm—Two Reels.)

REVIEWED BY CLIFFORD H. PANGBURN

NOW is the time when all good film producers and true seem to think they must rally to the support of the so-called "timely film." It is therefore very refreshing to see a picture which fits in this class so well as "England Expects——"

The market at the present is flooded with hastily thrown together pictures fondly supposed to have some connection with the war, but whose only real effect is to discredit the film industry. This offering is of an entirely different nature. It has a most direct connection with the war, and it is as interesting as it is well done.

Its genuineness is not its only remarkable characteristic. It possesses an attribute which is most rare in any form of dramatic production; namely, it drives home the point which it is intended to make, in a forcible and interesting manner. The idea of the picture is to arouse a healthy patriotic feeling on the part of the spectator. This is just what it does.

The effect is obtained by a very simple story, some extremely good child acting and a clever interpolation of scenes showing British soldiers on their way to the front. The picture cannot even be classed as unneutral, because it encourages patriotism so successfully as to make the spectator think only of his own country.

The story begins with England's declaration of war. A veteran of the Crimea is talking to his son, a veteran of the Boer War, they are congratulating each other on the fact that the old man's two grandsons can go even though they are too old.

The younger son is an officer in the army and everyone takes it as a matter of course that his brother will enlist.

He shrinks from the idea even when his wife urges him to go in spite of the pain it will cause her. He is about to sneak away to America, when he has a sudden change of heart caused by overhearing some of the things his children are saying to their mother. He enlists, and the whole family is proud of him.



Our 32-page catalogue No. 3, illustrated in colors, contains a large variety of artificial flowers, vines, garlands, shrubbery, palms, etc. Mailed free for the asking.

FRANK NETSCHERT COMPANY

Manufacturer and Importer of Artificial
 Flowers, Natural Prepared Plants, etc.

61 Barclay Street

NEW YORK

No Branch Office.

SPECIAL FEATURES

RELEASED THROUGH THE BRANCHES OF THE

General Film Company

TITLE	MAKE	No. of Reels	TITLE	MAKE	No. of Reels
THIRD DEGREE	Lubin	5	TREASURE OF ABDAR RAHMAN.....	Pathe	4
THOR, LORD OF JUNGLE.....	Selig	3	'NEATH THE LION'S PAW.....	Melies	3
THE BATTLE OF SHILOH.....	Lubin	4	ONE WONDERFUL NIGHT.....	Essanay	4
THE LION AND THE MOUSE.....	Lubin	6	WOMAN AGAINST WOMAN.....	K. & E. Biograph	3
THROUGH FIRE TO FORTUNE.....	Lubin	5	IN DEFIANCE OF LAW.....	Selig	3
JUDITH OF BETHULIA.....	Biograph	4	A KINGDOM AT STAKE.....	Kleine	3
GERMINAL	Pathe	5	CAPTAIN ALVAREZ	Vitagraph	6
LOST IN MID OCEAN.....	Vitagraph	3	OTHELLO	Kleine	5
A ROMANY SPY.....	Pathe	3	SHANNON OF SIXTH.....	Kalem	5
A CELEBRATED CASE.....	Kalem	4	MAN'S ENEMY	K. & E. Biograph	3
THE FULFILLMENT	Essanay	3	IN TUNE WITH THE WILD.....	Selig	3
NIGHT RIDERS OF PETERSHAM.....	Vitagraph	3	THE WOLF	Lubin	6
HARDING'S HERITAGE	Pathe	3	SHADOWS OF THE PAST.....	Vitagraph	3
DAUGHTERS OF MEN.....	Lubin	5	MR. BINGLES' MELODRAMA.....	Vitagraph	3
THE OTHER HALF OF THE NOTE.....	Kalem	3	MEN AND WOMEN.....	K. & E. Biograph	3
HER LADYSHIP	Selig	3	THE SECRET OF RING.....	Kleine	3
GOODNESS GRACIOUS	Vitagraph	3	MY FRIEND FROM INDIA.....	Edison	3
OFFICER JIM	Lubin	3	LIBERTY BELLES	K. & E. Biograph	3
DEATH SIGN AT HIGH NOON.....	Kalem	3	THE ERRING	Lubin	3
GAME OF LIFE.....	Selig	3	AMBUSHED	Essanay	3
THE MILITANT SUFFRAGETTE.....	Pathe	5	SONG OF THE SOUL.....	Kleine	3
FRANCIS MARION, "THE SWAMP FOX".....	Kalem	3	KIT, THE ARKANSAS TRAVELER.....	Kalem	3
A MILLION BID.....	Vitagraph	5	CHIP OF THE FLYING "U".....	Selig	3
THE FATAL WEDDING.....	K. & E. Biograph	3	FAIR REBEL	K. & E. Biograph	3
THE GAMBLERS	Lubin	5	HOUSE NEXT DOOR.....	Lubin	5
ANNE BOLEYN	Kleine	3	MY OFFICIAL WIFE.....	Vitagraph	5
STRUGGLE FOR LIFE.....	Pathe	5	UNCLE BILL	Vitagraph	3
MONGREL AND MASTER.....	Essanay	3	THE FORTUNE HUNTER.....	Lubin	6
THE ROYAL BOX.....	Selig	4	THE VENDETTA.....	Kleine	5
THE CURSE OF CREED.....	Melies	5	BAREFOOT BOY	Kalem	3
FACING THE FOOTLIGHTS.....	Pathe	3	THE WIFE	K. & E.	3
BLOOD WILL TELL.....	Essanay	3	KING OF CHANCE.....	Kalem	3
CONQUEST OF QUEBEC.....	Kalem	5	THE WAGES OF SIN.....	K. & E.	3
THE LILY OF THE VALLEY.....	Selig	3	THE PLUM TREE.....	Essanay	3
CLASSMATES	K. & E. Biograph	4	THE FIFTH MAN.....	Selig	3
MAN OF THE HOUR.....	Selig	3	THE GOLDEN BEETLE.....	Kleine	4
MR. BARNES OF NEW YORK.....	Vitagraph	6	THE WEIGHT OF A CROWN.....	Lubin	3
LOVE, LUCK AND GASOLINE.....	Vitagraph	3	MARAH, THE PYTHONESS.....	Lubin	3
THE BILLIONAIRE	K. & E. Biograph	3	CHARITY BALL	K. & E. Biograph	3
SPORT AND TRAVEL IN AFRICA.....	Pathe	5	HEARTS AND MASKS.....	Selig	3
THE GOOD FOR NOTHING.....	Essanay	4	A FLORIDA ENCHANTMENT.....	Vitagraph	5
THE BOER WAR.....	Kalem	5	ROAD TO YESTERDAY.....	K. & E. Biograph	3
THE THUMB PRINT.....	Melies	4	THE PAINTED WORLD.....	Vitagraph	3
STRONGHEART	K. & E. Biograph	3	JUDGE NOT	Kleine	4
LORD CHUMLEY	K. & E. Biograph	4	GARRISON'S FINISH	Selig	3
SEVEN DAYS	K. & E. Biograph	3	POWER OF THE PRESS.....	K. & E. Biograph	4
			IN THE GLARE OF LIGHTS.....	Essanay	3
			THE RED CROSS NURSE.....	Melies	3

"THE BROKEN PROMISE"

(Eclectic—Four Reels)

REVIEWED BY CLIFFORD H. PANGBURN

THIS picture was made in Sweden and on the island of Heligoland, which is now figuring as Germany's outpost in the North Sea. It concerns people in a little fishing village, and naturally contains many marine scenes. These are almost without exception of the highest order of excellence.

Several scenes have the harbor of the village for a background, and the groups of fishing boats at anchor, with the rugged hills rising beyond, make very effective backgrounds. One of these is particularly fine, as it shows a thin bank of fog stretched along the face of the mountain. As the action of the scene progresses the fog can be seen slowly rising.

A whole series of striking effects is seen during the pursuit of a smuggler's launch by one containing men from the coast guards. The chase is supposed to occur at night.

After the boats have gone some distance the smugglers' rounds a point, and, followed by that of the officers', goes toward the horizon along the path of the moon's reflection in the water. A beautiful silhouette effect is the result.

The acting shows some tendency toward those gesticulatory excesses which are often seen in pictures made on the Continent, but is good in spite of this. The characters themselves are strikingly good. The heroine is a humble orphan in a small village, and she looks the part, with no attempt to appear a grand lady in disguise. The other persons in the story are equally realistic. The story tells of Inge and the gross unfaithfulness of her lover. She is a maid in a wealthy fisherman's family, and accepts the advances of Jan, the son of the house, upon his promise of marriage.

Jan becomes a smuggler, and is saved from what seems like certain arrest by the bravery of Inge. However, he prepares to marry another girl, even when he knows that the faithful, but over-credulous, Inge is about to become a mother.

Driven to desperation, the girl tells the officers of Jan's

"AT THE OLD CROSS ROADS"

(Select Photoplay—Alliance—Five Reels)

REVIEWED BY H. S. FULD

THE fact that this story, though taking five reels in the telling, never lacks interest and holds the attention right through to its climax, is enough to make it a feature among features. So many recent pictures have so much "padding" to carry them over three reels, that it is a relief to see one where there is action and "go" in every foot.

Each scene is blended with the next with such smoothness and despatch that though the climax or denouement is kept hidden until the last few hundred feet, the interest never lags.

The exteriors are well chosen, especially the love scene



PAREPA IS ACQUITTED

on the bridge, where Tom Martin proposes to Annabel. Estha Williams deserves special mention for her rendering of Parepa Mendoza. Her facial expression and gestures, though they may seem exaggerated, are really in keeping with the difficult part she has to play.

The struggle between Dayton Thornton and James Martin, impersonated by Arthur Morrison and Frank L. Dear, respectively, is very realistic, especially when they fall down the front steps, locked in each other's arms. Rae Forde in her characterization of Annabel Thornton does a realistic fall from her horse, when she is found by James Martin, and carried in his arms to the house. The court scenes are not lacking in detail, and the characters even to the twelve men making up the jury act their parts true to life.

The picture relates a tragedy due to the result of race prejudice. After it is all over and the last tragedy has been enacted comes the startling surprise that the woman who was thought to be a negress is of Spanish blood.

"THE GIRL AND THE STOWAWAY"

(Kalem—Two Reels.)

REVIEWED BY CLIFFORD H. PANGBURN

MOST of the scenes in this picture are on shipboard, and the result is a considerable variation from the usual. The photographic work is excellent, and a number of uncommon effects have been obtained. Alice Joyce is featured, although the lead is really played by Tom Moore. Others in the cast are William Bestman, Anna Burmeister, James Ross, Mary Ross and Marguerite Courtot.

Miss Joyce and Mr. Moore play their parts with customary effectiveness, even when it comes to jumping from a large steamer into the turbid waters of the Hudson near a dock.

The plot is the familiar one of a young man and woman refusing an arranged marriage without ever having seen each other, and subsequently falling in love.

A young English nobleman quarrels with his father over matrimonial plans, and starts for America as a stowaway on the same ship with the girl in question. They meet and fall in love under romantic circumstances.



THE WEDDING INTERRUPTED

dishonesty and where he conceals his goods. Then she repents and sends a warning. Jan rushes away in the midst of the marriage ceremony. Inge tries to take him away, but their sail boat is pursued by the coast guard. Jan is shot down, the boat capsizes and the unhappy lovers drown together.

COMPLAINS COTTON MARKET AFFECTS FILMS

Special to THE MOTION PICTURE NEWS

Dallas, Oct. 6.

LOCAL film men are now complaining that the European war is affecting their business to some extent. They say that owing to the poor cotton market they are not playing to as large houses as before the war started.

As there is no market for cotton at this time, the people are not spending as much money for amusements.

Your Show Window

Perhaps you do not realize it, but your lobby is the Show Window of your theatre, and your attractions will be judged by your display.

Announcement

We are now sole authorized manufacturers of lobby photos, by exclusive contract with

THE GENERAL FILM COMPANY

Also sole authorized manufacturers of lobby photos, by exclusive contract with

THE UNIVERSAL FILM MANUFACTURING COMPANY

The reason is because we make the best and the manufacturers will sanction nothing else.

11 x 14, Suitable for framing (Sepia),
\$1.50 per doz.

22 x 28, Suitable for framing (Sepia),
40c. each.

22 x 28, Suitable for framing, Hand Colored, \$1.00 each.

If your pictures are not miles ahead of any pictures on the market, return them at our expense.

Have you heard of our coupon plan? If not—write us.

Order from your exchange or

Wyanoak Publishing Co.

136-146 West 52d Street

NEW YORK, N. Y.

LUBIN SERIES MAKES BIG HIT

THE success of "The Beloved Adventurer" series has so far surpassed all expectations. Every exhibitor who presents first run Lubin pictures are sending in appreciations of the picture, and reports enormous sales of the book, which tells the tale of the adventures of Lord Cecil. Twenty-five cents for a cloth-bound copy has placed it within the reach of everybody.

Only two of the series have so far been exhibited, but was sufficient to create a longing for the whole fifteen pictures, which are now completed and ready for release every Monday. The book is handsomely gotten up and profusely illustrated, and if the demand continues will probably be out of print within the next thirty days.

"THE TREY O' HEARTS"

(Gold Seal—Universal—Eleventh Chapter.)

REVIEWED BY PETER MILNE

THIS episode, entitled "The Painted Hills," introduces a touch of Western melodrama, and in this respect might be compared with an instalment of its famed predecessor, "Lucille Love."

As before noted in the review of that chapter concerning the adventures of Lucille, the fact that the interest is sustained by the wonderful riding and all the accompanying thrillers that are usually seen in a Western, does not belittle or detract from the merits of the picture in the least.

Cleo Madison as Judith Trine, who boasts both of her father's devilish temper and her sister's beauty, proves that she is no mean fighter in this episode.

Indeed, her art in that line has been in no way concealed up to date, but here she engages single-handed in a tussle with a regular bad man, on the top of a high hill. The masculine combatant receives the little end of the encounter, and performs a dare-devil fall down the hill.



THE ESCAPE FROM MARROPHAT

The fact that he executes this feat of daring just as if he did such things every day in his life, and moreover very naturally, makes it all the more hair-raising. And as he rolls over and over down the hill, where it was his wicked intention to send a boulder down upon the heads of Law and Rose, it will be asking too much to imagine that Hopi, for that is the bandit's name, was not severely bruised when he reached his destination.

Miss Madison herself performs a fine feat of daring, which perhaps will not create such a sensation, as it appears easy. She is tied to a horse's back by the revengeful Hopi. The horse gallops away with her, and she is only rescued by Allen.

The general aspect of the story has changed since its outset, as now Judith, although apparently striving to kill Law, has had several opportunities, and has failed to grasp them. Her father, however, thinks that she is still loyal to him and his dastardly plans, which have so far never been realized to their full extent.

The eleventh chapter is destined to maintain the popularity of the series.

"FALSE PRIDE HAS A FALL"

(Albuquerque—Warners—Four Reels)

REVIEWED BY CLIFFORD H. PANGBURN

THE usual excellent photographic and scenic effects which mark the work of the Albuquerque company are seen in this picture. The scenes supposed to depict an expensive and exclusive girls' finishing school are not convincing, so far as exclusiveness and expensiveness go.

On the other hand, a number of incidents of a kind usually imperfectly presented in such a picture are shown with much effect. An instance is the one in which the heroine falls from an excursion steamer.

The story opens on a Western farm at the close of the local school year. The teacher advises the parents of one of her



THE NEW GIRL HAS TROUBLE

pupils to send her to a girls' school. As they have been prosperous, they do so.

When she arrives at the school the girl is a startling example of an uncouth and unsophisticated country lass. She soon changes completely, and thinks of home chiefly as a source of funds. She becomes engaged and does not even postpone her marriage when her father is hurt and unable to come to the wedding.

Later the old folks come for a visit. Their daughter fears that they will disgrace her by their country ways, and as she has a dance planned for the evening she gives them much champagne for supper. They become very sleepy and retire. Later they wake up and join the dance in a very impromptu manner. The party is broken up, and the daughter is very indignant. When she sees the old people starting home she realizes her unkindness. A final scene shows the family reunited at the farm.

"IN THE POWER OF THE DUKE"

(Warner's Features—Three Reels)

REVIEWED BY CLIFFORD H. PANGBURN

STARTLING thrills, including nearly all of the sort dear to the lover of melodrama, go to make this film a lively one. There is a large amount of beautiful scenery, while the views taken about the old castle are most unusual. The photographic work is of the high order which is usually found in pictures of French or Italian make.

One striking feature is the number of scenes which are taken from positions which offer an extended view of the country in the background. The acting is a trifle gesticulatory, but very good, all things considered.

The story is of a highly melodramatic nature, but rather entertaining. A man released from prison after a term of fifteen years, goes to see his daughter, who had been placed while an infant with a friend. He is told that she has left home.

In revenge he betrays his friend's supposed daughter to a duke, who wishes to ruin her. Then he learns that she is really his daughter. He rescues her after a series of the most startling adventures. He is fatally injured in doing so, but dies happily to see his daughter safe with her honest lover.

**THE ALBUQUERQUE FILM
MFG. COMPANY, Inc.**

Featuring that clever
Comedienne

Miss Dot Farley

Two Comedies Weekly

RELEASING THROUGH
The United Motion Picture Producers, Inc.
WHO DISTRIBUTE THROUGH
Warner's Features, Inc.

By request from many exchanges
we take pleasure in
reviving the

**FRONTIER
TWIN STORIES**

Written and made famous by Miss Dot
Farley. Under direction of

Gilbert P. Hamilton

Farce Comedy Production

BY

ARCHER McMACKIN

Nuf Sed

WESTERN STUDIO

406 Court St.

Los Angeles, Calif.

GILBERT P. HAMILTON, Pres. and Gen. Mgr.

What Do You Need?

LISTING IN THE BUYERS' GUIDE, FOR NAME AND ADDRESS, INCLUDING ONE YEAR'S SUBSCRIPTION TO THE MOTION PICTURE NEWS—\$8.00 A YEAR, CASH IN ADVANCE. FREE TO ADVERTISERS USING \$100.00 OR MORE WORTH OF DISPLAY SPACE DURING THE YEAR. ADDRESS ADVERTISING DEPARTMENT

ADVERTISING NOVELTIES

Philip Hano, 806-810 Greenwich St., New York.

ANNOUNCEMENT SLIDES

Niagara Slide Co., Lockport, N. Y.

ASBESTOS BOOTHS

Sharlow Bros., 442 W. 42nd St., New York.

CLEANING AND RENOVATING FILM

Film Redeveloping Co. of America, 145 W. 45th St., N. Y.
Multicolor Film Improving Co., Inc., 15 E. 26th St., N. Y.

COSTUMERS

Miller-Costumier, 236 South 11th St., Philadelphia, Pa.

DEVELOPING TANKS

A. J. Corcoran, Inc., 9½ John St., New York.

ELECTRIC LIGHTING SETS

The Chas. A. Strelinger Co., Box P-2, Detroit, Mich.

FILMS

(Manufacturers, Dealers and Renters)
American Film Mfg. Co., Chicago, Ill.
Thomas A. Edison, Inc., 275 Lakeside Ave., Orange, N. J.
Essanay Film Mfg. Co., First National Bank Bldg., Chicago, Ill.
General Film Co., 200 Fifth Ave., New York.
George Kleine, 166 N. State St., Chicago, Ill.
Lubin Mfg. Co., Philadelphia, Pa.
G. Melies, 204 E. 38th St., New York.
Mutual Film Corp., 71 W. 23rd St., New York.
New York Motion Picture Corp., Longacre Bldg., New York.
Pathé Freres, 1 Congress St., Jersey City, N. J.
Renfax Film Co., Inc., 110 W. 40th St., N. Y.
Selig Polyscope Co., Chicago, Ill.
Thanhouser Film Corp., New Rochelle, N. Y.
Universal Film Mfg. Co., 1600 Broadway, N. Y.

FILM ACCESSORIES

Berlin Aniline Works, 213 Water St., N. Y.

FILM TITLES, PRINTING, DEVELOPING, ETC.

Commercial Motion Pictures Co., Inc., 220 W. 42nd St., New York.
Centaur Film Co., 670-682 Ave. E, Bayonne, N. J.
Evans Film Mfg. Co., 412-22 W. 216th St., at Broadway, New York.
Gunby Bros., Inc., 145 W. 45th St., New York.
Industrial Moving Picture Co., 223-233 W. Erie St., Chicago.
Standard Motion Picture Co., 5 S. Wabash Ave., Chicago.
Standard Filmprint Corp., 120 School St., Yonkers, N. Y.

FILM REELS

Lang Mfg. Works, Olean, N. Y.
Taylor-Shantz Company, 224 Mill St., Rochester, N. Y.

FURNITURE AND FURNISHING ON RENTAL

William Birns, 103-105 West 37th St., N. Y.

FEATURE FILMS

Alco Film Corp., 218 W. 42d St., New York.
Alliance Films Corp., 126 W. 46th St., New York.
Albuquerque Film Mfg. Co., Inc., 406 Court St., Los Angeles, Calif.
All Star Feature Corp., 220 W. 42nd St., N. Y.
Ambrosio American Co., 15 E. 26th St., N. Y.
Bosworth, Inc., 640 N. Olive St., Los Angeles, Cal.
Box Office Attraction Film Rental Co., 130 W. 46th St., New York.
A. Blinkhorn, 110 W. 40th St., New York.
California Motion Picture Corp., San Francisco, Cal.

Cosmofotofilm Co., 110 W. 40th St., New York.
Cosmos Feature Film Corp., 126-130 W. 46th St., N. Y. City.

Direct-From-Broadway Features Co., 46 W. 24th St., New York.

Eclair Film Co., 126 W. 46th St., New York.
Eclectic Film Co., 110 W. 40th St., New York.
Excelsior Feature Film Corp., Inc., 110 W. 40th St., N. Y.

G. W. Feature Film Corp., 145 W. 45th St., N. Y.

Features Ideal, 126 W. 46th St., New York.
Famous Players Film Co., 213-229 W. 26th St., New York.

Films Lloyds, Inc., 220 W. 42nd St., N. Y.
General Film Co., 200 Fifth Ave., New York.
General Feature Film Co., 313 Mallery Bldg., Chicago, Ill.

Gaumont Co., 110 W. 40th St., New York.
Greene's Feature Photo Plays, Inc., 110 W. 40th St., New York.

W. W. Hodkinson, 110 W. 40th St., New York.
Imperial Motion Picture Co. of N. Y., Inc., 1476 Broadway, N. Y.

Inter-Continent Film Co., 110 W. 40th St., New York.

George Kleine Attractions, 166 N. State St., Chicago, Ill.

New York Office: 1476 Broadway.
Jesse L. Lasky Feature Play Co., Longacre Theatre, New York.

Life Photo Film Corp., 220 W. 42nd St., N. Y.
Mecca Feature Film Co., Inc., 126 W. 46th St., New York.

Mohawk Film Co., Times Bldg., New York.
Oz Film Mfg. Co., Santa Monica Blvd., Los Angeles, Cal.

Paramount Pictures Corp., 110 W. 40th St., New York.
Phoenix Feature Film Corp., 164 Federal St., Boston, Mass.

Photo Play Production Co., 220 W. 42nd St., New York.

Picture Playhouse Film Co., 110 W. 40th St., New York.

Playgoers Film Co., Lyric Theatre, New York.
Popular Plays and Players Co., 1600 Broadway, New York.

Progress Film Co., 110 W. 40th St., New York.
Progressive Motion Picture Corp., Times Bldg., New York.

Ramo Films, Inc., Columbia Theatre Bldg., New York.

Rolands Feature Film Co., 145 W. 45th St., New York.

A. H. Sawyer, Inc., 1600 Broadway, New York.
Select Photo Play Producing Co., Inc., 71 W. 23rd St., New York.

Sterling Camera & Film Co., 145 W. 45th St., New York.

Solax Co., Fort Lee, N. J.
The Masterpiece Film Mfg. Co., 1111 Van Nuys Bldg., Los Angeles, Cal.

The Photoplay Productions Releasing Co., 37 S. Wabash Ave., Chicago, Ill.
Union Features, 126 W. 46th St., New York.

Universal Film Mfg. Co., 1600 Broadway, N. Y.
University Films, Inc., 110 W. 40th St., N. Y.

Edw. H. Wagner, Agt., Dania Biofilm Co., 38 Park Place, N. Y.
World Film Corporation, 130 W. 46th St., New York.

Warner's Features, Inc., 130 W. 46th St., N. Y.

LANTERN SLIDE MATS AND REEL BANDS

Lantern Slide Mat Co., 149 W. 35th St., N. Y.

LABELS

Every Ready Roll Label Co., 203-7 W. 40th St., New York City.

LIGHTING PLANTS

Cushman Motor Works, Lincoln, Neb.

LOBBY PHOTOS

The Wyanoak Pub. Co., 136 W. 52nd St., N. Y.

MOTION PICTURE MACHINES AND SUPPLIES

Amusement Supply Co., 160 E. North Fifth Ave., Chicago, Ill.

Calehuff Supply Co., 1301 Race St., Philadelphia, Pa.

Enterprise Optical Co., 568 W. Randolph St., Chicago, Ill.

Lears Theatre Supply Co., Sam Lears, Prop., 509 Chestnut St., St. Louis, Mo.

Oliver Moving Picture Supply Co., 647 Euclid Ave., Cleveland, O.

Picture Theatre Equipment Co., 21 E. 14th St., New York.

Precision Machine Co., 317 E. 34th St., N. Y.

Nicholas Power Co., 90 Gold St., New York.

The Phantoscope Mfg. Co., Washington, D. C.

Sweeley's Photo Supply House, 514-516 Erie Ave., Renova, Pa.

Williams, Brown & Earle, Inc., 916-918 Chestnut St., Philadelphia, Pa.

MOTION PICTURE APPARATUS

Burke & James, Inc., 240-258 E. Ontario St., Chicago, Ill.

MUSICAL INSTRUMENTS

Rudolph Wurlitzer Co., Cincinnati, O.
American Photoplayer Co., 62 W. 45th St., New York City.

POSTER AND PICTURE FRAMES

Menger & Ring, 442 W. 42nd St., New York.

RAW FILM

Eastman Kodak Co., Rochester, N. Y.
Celluloses Planchon, Inc., 75 Fifth Ave., New York.

David Horsley, 1600 Broadway, N. Y.
Raw Film Supply Co., 15 E. 26th St., N. Y.

OPERA CHAIRS

The Hardesty Mfg. Co., Canal Dover, Ohio.
Steel Furniture Co., Grand Rapids, Mich.

PIPE ORGANS

Henry Pilcher's Sons, 914-920 Mason Ave., Louisville, Ky.
M. P. Moller, Hagerstown, Md.

PROJECTION LENSES

Bausch & Lomb Optical Co., 569 St. Paul St., Rochester, N. Y.

POSTERS

The Morgan Lithograph Co., Cleveland, Ohio.

REWINDERS AND GENERAL SUPPLIES

L. C. Smith Co., Schenectady, N. Y.

SCREENS

Atsco, Inc., 218 West 42nd St., New York.
Day & Night Screens, Inc., 110 W. 40th St., New York.
Mirror Screen Co., Inc., Shelbyville, Ind.

STEEL FILM EQUIPMENT FOR EXCHANGES AND MFRS.

Columbia Metal Box Co., 226-228 E. 144th St., New York.

TICKETS—ROLL AND COUPON

Rees Ticket Co., 400 S. 10th St., Omaha, Neb.

THEATRE LOBBY FRAMES AND FIXTURES

Newman Mfg. Co., 715 Sycamore St., Cincinnati, O.

UNIFORMS

Fechheimer Bros., Union-made Uniforms, Cincinnati, O.

VENTILATION, COOLING AND HEATING

Typhoon Fan Co., 1544 Broadway, N. Y.

BETTER LIGHT

LESS CURRENT

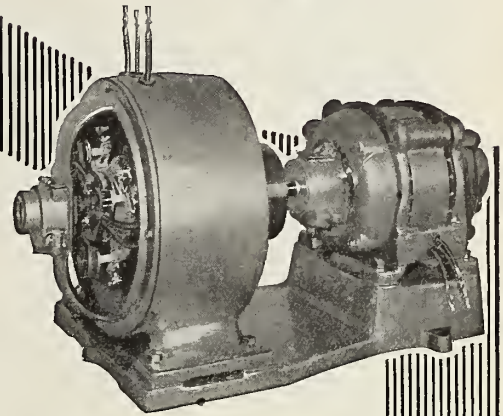
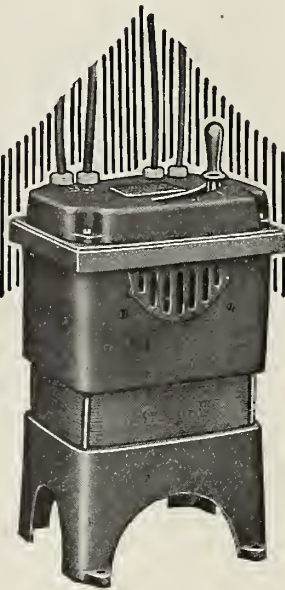
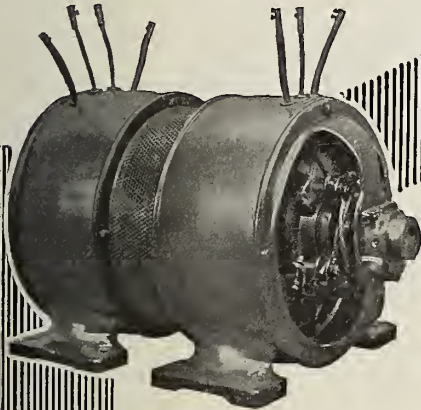

The DC Compensarc lowers the voltage of a direct current supply to that required at the lamp without needless waste.

The AC Compensarc cuts $\frac{2}{3}$ from your lighting bill if you use alternating current.

The AC to DC Compensarc will transform alternating into direct current and reduce the voltage at the same time without need less waste.

No matter what current you have---Alternating or Direct---or what voltage or frequency, one of the

FORT WAYNE COMPENSARCS

will enable you to secure a light that will give those clear, bright pictures that everybody now demands.

What's the use of paying extra money for special screens, projecting machines, and first run films and then spoil the whole result with poor light? With the Fort Wayne Compensarcs you can get any kind of light you want regardless of the kind or quality of your current supply.

The Compensarcs will give you

STEADY LIGHT. No flickering, no sputtering, even when changing intensities or from one machine to another.

WHITE LIGHT. No yellow streaks, no ghosts.

BRIGHT LIGHT. Three times the light with two-thirds the current.

They are safe, efficient, easy to operate, fool proof and reliable.

FORT WAYNE ELECTRIC WORKS

OF GENERAL ELECTRIC COMPANY

1704 BROADWAY

FORT WAYNE, INDIANA



Compensarcs are so commonly found in motion picture theatres that many people now call all current saving and transforming devices by that name.

But Remember

*If it isn't a FORTWAYNE
it isn't a "COMPENSARC"*

*Send TODAY for this
FREE descriptive booklet*

Record of Current and Coming Releases

GENERAL FILM PROGRAM

RELEASES OF THE WEEK

Monday, October 5, 1914.

BIOGRAPH—The Borrowed Book, D., 1000.....	16121
EDISON—Father's Beard, C., 1000.....	16127
ESSANAY—The Fickleness of Sweedie, C., 1000..	16129
KALEM—The Dancer, D., 2000.....	16122
LUBIN—An American Heiress, The Beloved Ad- venturer, Series No. 4, D, 1000.....	16130
SELIG—The Moving Picture Cowboy, C., 2000...	16124
SELIG—Hearst-Selig News Pictorial No. 63, N., 1000	16128
VITAGRAPH—Fisherman Kate, C., 1000.....	16126

Tuesday, October 6, 1914.

BIOGRAPH—Gwendolin, D., 1945.....	16141
COLUMBUS—What Would You Do? C., 1000.....	16139
EDISON—Greater Love Hath No Man, D., 1000..	16131
ESSANAY—The Verdict, D., 1000.....	16132
KALEM—For the Love of Mike, C., 800.....	16140
Hesant Hunt Wild Game, C., 200.....	
KLEINE—The Wrecked Special, D., 2000.....	16133
LUBIN—Wife's Athletic Mamma, C., 400.....	16138
A Hunting Absurdity, C., 600.....	
SELIG—The Way of the Redman, D., 1000.....	16135
VITAGRAPH—His Unknown Girl, D., 2000.....	16136

Wednesday, October 7, 1914.

EDISON—Seth's Sweetheart, C., 1000.....	16143
ESSANAY—The Fable of "The Family That Did Too Much for Nellie," C., 1000.....	16146
KALEM—The Lost Mail Sack, D., 2000.....	16144
LUBIN—The Girl at the Lock, D., 2000.....	16149
SELIG—The Reparation, D., 1000.....	16148
VITAGRAPH—Kill or Cure, C., 1000.....	16147

Thursday, October 8, 1914.

BIOGRAPH—Their Little Drudge, D., 1000.....	16151
COLUMBUS—The New Apprentice, C., 750.....	16155
Kissing Germ, C., 250.....	
ESSANAY—When Slippery Slim Met the Cham- pion, C., 1000.....	16152
LUBIN—In Old Virginia, D., 2000.....	16153
SELIG—Hearst-Selig News Pictorial No. 64, N....	16157
VITAGRAPH—The Loan Shark King, D., 1000..	16156

Friday, October 9, 1914.

BIOGRAPH—They Were College Boys, C., 496...	16167
The Man Hunters, C., 503.....	
EDISON—The Long Way, D., 3000.....	16158
ESSANAY—The Real Agatha, D., 2000.....	16161
KALEM—The Tattered Duke, C., 1000.....	16163
LUBIN, The Green Eyed Monster, D., 1000.....	16166
SELIG—Jimmie, the Porter, C., 500.....	16164
Doc Yak's Bottle, C., 500.....	
VITAGRAPH—Josie's Legacy, C., 1000.....	16165

Saturday, October 10, 1914.

BIOGRAPH—His Mother's Home, D., 999.....	16174
EDISON—A Fragment of Ash, D., 1000.....	16168
ESSANAY—Broncho Billy and the Greaser, D....	16169
KALEM—Fate's Midnight Hour, D., 1000.....	16173
LUBIN—When the Ham Turned, C., 1000.....	16170
SELIG—Her Victory Eternal, D., 1000.....	16175
VITAGRAPH—The Rose and the Thorn, D., 2000..	16171

RELEASES OF NEXT WEEK

Monday, October 12, 1914.

BIOGRAPH—The Guiding Fate, D., 1004.....	16176
EDISON—Buster Brown's Education, C., 500.....	16182
George Washington Jones, C., 500.....	
ESSANAY—Sweedie Learns to Swim, C., 1000....	16184
KALEM—The Girl and the Stowaway, C., 2000....	16177
LUBIN—The Girl from the West, Fifth of the Be- loved Adventurer Series, D., 1000.....	16185
SELIG—The Dream Girl, D., 2000.....	16179
VITAGRAPH—Midst Woodland Shadows, D., 1000	16181

Tuesday, October 13, 1914.

BIOGRAPH—The Iron Master, D., 2017.....	16196
COLUMBUS—Why Skunkville Went Dry, C., 1000	16194
EDISON—The Letter That Never Came Out, D., 1000	16186
ESSANAY—Through Eyes of Love, D., 1000.....	16187
KALEM—Percy Pimpnickel-Soubrette, C., 1000..	16195
KLEINE—On the Battle Line, D., 2000.....	16188
LUBIN—Swami Sam, C., 400.....	16193
Neighborly Neighbors, C., 600.....	
SELIG—The Mexican, D., 1000.....	16190
VITAGRAPH—Mareea, the Foster Mother, D., 2000	16191

Wednesday, October 14, 1914.

EDISON—Andy and the Redskins, C., 1000.....	16198
ESSANAY—The Fable of "The Author and the Dear Public and the Plate of Mush," C., 1000	16201
KALEM—Seed and the Harvest, D., 2000.....	16199
LUBIN—The Bond of Womanhood, D., 2000.....	16204
SELIG—The Mysterious Beauty, C., 1000.....	16203
VITAGRAPH—The Peacemaker, C., 1000.....	16202

Thursday, October 15, 1914.

BIOGRAPH—The First Law, D., 1000.....	16206
ESSANAY—Snakeville's Peacemaker, C., 1000.....	16207
LUBIN—The Imposter, D., 2000.....	16208
SELIG—Hearst-Selig News Pictorial No. 66, N., 1000	16211
VITAGRAPH—His Dominant Passion, D., 1000...	16210

Friday, October 16, 1914.

BIOGRAPH—Peg O' the Wild-Wood, D., 1000....	16220
EDISON—On the Isle of Sarne, C., 2000.....	16212
ESSANAY—The Other Man, D., 2000.....	16214
KALEM—Si's Wonderful Mineral Spring, C., 1000.	16216
LUBIN—The Long Lane, D., 1000.....	16219
SELIG—The Man-Hater, C., 1000.....	16217
VITAGRAPH—Fatty's Sweetheart, C., 1000.....	16218

Saturday, October 17, 1914.

BIOGRAPH—Meeting Mr. Jones, C., 469.....	16227
Our Home-Made Army, C., 532.....	
EDISON—The Case of the Vanished Bonds, D., 1000	16221
ESSANAY—Broncho Billy Rewarded, D., 1000....	16222
KALEM—From Peril to Peril, D., 1000.....	16226
LUBIN—The Smuggler's Daughter, C., 1000.....	16223
SELIG—The Woman of It, D., 1000.....	16228
VITAGRAPH—The Girl in the Case, D., 2000.....	16224

ALCO'S SECOND RELEASE

The second release of the Alco Film Corporation is Andrew Mack, in "The Ragged Earl," on Monday, October 12. The play is one of the best of Mr. Mack's many stage successes and will prove equally popular on the screen. The story of the Emerald Isle was produced by the Popular Plays and Players' Company, which spared no expense in the production, and who adhered to the atmosphere in the most minute detail of the picture. The two hundred and eighty-nine scenes are typical of the Irish country, and to one who has visited Ireland the different views are recognizable. This is Mr. Mack's first appearance in motion pictures, and judging by the demand for him as a picture star, it will be the beginning of a series of pictures from many of the successes of this favorite portrayer of Irish types on the legitimate stage.

The artistry of this production is beyond conception and is in keeping with the standard of photo plays to be released through the Alco Film Corporation.

SYRACUSE CRITICS REVIEW PHOTO PLAYS

Special to THE MOTION PICTURE NEWS

Syracuse, Oct. 7.

"Neptune's Daughter" and "Cabiria" were heralded with such great acclaim in Syracuse that the local papers decided to review the productions.

One critic wrote at length on one of the features and admitted that he was among the many who applauded the picture in several of its scenes.

He remarked that "it is on a rare occasion nowadays that a road show receives a real, genuine 'hand' of applause, and when motion pictures can tell a story with realism sufficient to call forth the applause I heard last night, well, I am going to review more of them."

MACON, GA., THEATRE REOPENS

Special to THE MOTION PICTURE NEWS

Macon, Oct. 6.

The Palace Theatre, Macon's popular amusement house, reopened September 21. It cost \$35,000, and is the finest motion picture house in the south, and a theatre that Macon people can point to with pride.

The entire plan of the old Palace has been changed and enlarged. It is better ventilated, has more music, has up-to-date lighting system, and comfortable seats.

"RELEASE" FOUR PLAYERS BY FILM MATRIMONY

Edgar Lewis, feature film director, tells an amusing incident of retrenchment in a New York studio. The studio had been producing a serial film featuring one of their actresses.

When the war scare hit the motion picture industry the directors of the film held a consultation and upon orders from the man higher up decided to release four players.

Several alternatives were suggested by which the actors and actresses might be permitted to retire gracefully from the serial. Finally it was decided to have a double wedding and in the next issue of the film, after much palavering, rolling of eyes and heart-to-heart "business" of parting, two young men and two much older character actresses were united in the wholly mercenary bonds of film matrimony to disappear forever from the scene.

TRENTON HOUSE UNDER NEW MANAGEMENT

Special to THE MOTION PICTURE NEWS

Trenton, N. J., Oct. 7.

Once again the Little Hippodrome, a pretty playhouse on North Warren street, opposite West Hanover, is under new management. This playhouse is now being operated under the firm name of Shafer and Teft. Motion pictures only are shown.

The new firm of the Empire Theatre, New Brunswick, N. J., announces that only the best in motion pictures will be shown. The house has been renovated. Shows are to be run from 1 o'clock p. m. until 10.30 o'clock evenings every day through the week.

Make Your Lobby Display Attractive

There is nothing more fascinating to the public than a bright brass frame to display your photos or posters. We make Lobby and Theatre Fixtures and Brass Ralls of every description.

Don't fail to visit our Showrooms. Write for catalog.

THE NEWMAN MFG. CO.

717 Sycamore St. Cincinnati, Ohio
Branch Factories and Show Rooms:
101 Fourth Ave. New York, N. Y.
106-108 W. Lake St. Chicago, Ill.
Established 1882.



Save 35%

on your
CARBONS
Burn your stubs with a
CARBON
Economizer

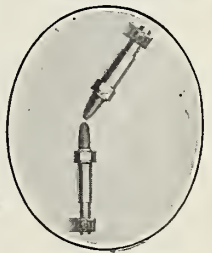

Pat. Appl. for

Fits any lamp, gives perfect contact and conductivity, screw does not come in contact with carbon and will not weld to body of economizer, will burn UPPER or LOWER carbon from 6 inches to 3/4 of an inch, is simple, practical, will last years with perfect results, and pay for itself in a few days.

"MECHANICALLY CORRECT"!!

\$1.25 Sizes \$2.00
Each. 1/2", 3/8", 3/4". Upper and Lower Set.
Sent **POSTPAID** upon receipt of draft, money order or cash.

THE CARBON ECONOMIZER CO.
757 W. Onondaga St., Syracuse, N. Y.

NO WAR BOOST ON OUR PRICES

Regardless of the present European unpleasantness we continue to use all essential chemicals such as **METOL AND HYDROQUINONE** and consistently maintain standard prices for quality **DEVELOPING AND PRINTING**

Send today for our price, quality and service guarantee.
INDUSTRIAL MOVING PICTURE CO. 223-233 West Erie Street, Chicago

You Throw Your Money Away

when you pay big prices for new film and project it on a worn out machine.

You cannot expect steady, clear and flickerless pictures from an old style projector.

Perfect projection can only be obtained by a first class machine. We are distributors of the Motiograph, Powers, Simplex and Edison Machines and Genuine Repair Parts and Supplies.

WE SELL FOR CASH OR ON EASY PAYMENTS

WRITE TODAY FOR OUR PLAN

CATALOG FREE

AMUSEMENT SUPPLY COMPANY, 160 No. Fifth Ave., CHICAGO

Manufacturers of the Wonderful Rembusch Patented Glass **MIRROR SCREEN** and all other kinds of Curtains for Moving Picture Projection

GLASS SCREENS
Mirror Screen
Mirror Screen Split
Glass Transparent Screen for Rear Projection

METALLIZED SCREENS
Gold Fibre
Silvercloth
Mirror Cloth
Seamless, with stretchers
White Opaque

Phone Seven-Eleven

F. J. REMBUSCH, Pres.

MIRROR SCREEN COMPANY

Incorporated

SHELBYVILLE, INDIANA

Mr. O. P. Sammons of Denison, Texas, bought a "Mirror Screen," and he writes that he cannot take care of the crowds. His picture is simply the talk of the community. A few second-hand screens for sale cheap.

Eastern Representative, Frank Manning, 125 W. 48th St., N. Y. Phone, Bryant 2416.

RECORD OF CURRENT AND COMING RELEASES—Continued

UNIVERSAL PROGRAM

RELEASES OF THE WEEK

Monday, October 5, 1914.

IMP—Shadows, D., 2000.....
STERLING—Myers Mistake.....
VICTOR—Disillusioned, D.....

Tuesday, October 6, 1914.

CRYSTAL—Liferitis, C.....
GOLD SEAL—The Trey o' Hearts, Episode 10....
UNIVERSAL IKE—Three of a Kind, C.....

Wednesday, October 7, 1914.

ECLAIR—The Line Rider, D., 2000.....
JOKER—The Baseball Fans in Fanville, C.....
NESTOR—The Old Bell Ringer, D.....

Thursday, October 8, 1914.

IMP—Universal Boy in "Rural Adventures," D...
REX—A Law Unto Herself, D., 2000.....
STERLING—Hypnotic Power, C.....

Friday, October 9, 1914.

NESTOR—He Never Said a Word, C.....
POWERS—The Mayor's Manicure.....
VICTOR—The Woman Who Won, C., 2000.....

Saturday, October 10, 1914.

101 BISON—The Phantom Light, D., 2000.....
JOKER—Cruel, Cruel World, C.....

Sunday, October 11, 1914.

ECLAIR—Cupid Victor, 1000.....
FRONTIER—Dolly's Deliverance, D.....
REX—Virtue Its Own Reward, D., 2000.....

RELEASES OF NEXT WEEK

Monday, October 12, 1914.

IMP—Mary's Convert, Mary Pickford Reissue, D..
STERLING—The Close Call.....
VICTOR—His Father's Son, D.....

Tuesday, October 13, 1914.

CRYSTAL—Oh, You Gypsie Girls and Some Col-
lectors, C.....
GOLD SEAL—Trey o'Hearts Episode No. 11, D.,
2000

UNIVERSAL IKE—Mary Green's Husband and
the Monkey Cabaret, C., Split Reel.....

Wednesday, October 14, 1914.

ECLAIR—The Squatter, D., 3000.....
JOKER—On Again, Off Again, Finnigan, C.....
NESTOR—No Release This Week.....

Thursday, October 15, 1914.

IMP—The Futility of Revenge, D., 2000.....
REX—Her Life's Story, D.....
STERLING—Heinie's Outing, C.....

Friday, October 16, 1914.

NESTOR—The Way of Life, D.....
POWERS—The Padrone's Ward, D., 2000.....
VICTOR—The Funny Mr. Dingle, C.....

Saturday, October 17, 1914.

101 BISON—Monsieur Bluebeard, D., 2000.....
JOKER—Across the Court, C.....

Sunday, October 18, 1914.

ECLAIR—The Quarrel, D.....
FRONTIER—In the Hollow of an Oak, D.....
REX—Kid Regan's Hands, D., 2000.....

MUTUAL PROGRAM

RELEASES OF THE WEEK

Monday, October 5, 1914.

AMERICAN—Daphnia, D., 2000.....
KEYSTONE—Their Ups and Downs, C., 1000....
RELIANCE—Our Mutual Girl, No. 38.....

Tuesday, October 6, 1914.

BEAUTY—Nieda, D.....
MAJESTIC—The Unpainted Portrait, D.....
THANHOUSER—The Cripple, D., 2000.....

Wednesday, October 7, 1914.

AMERICAN—Billy's Rival, D.....
BRONCHO—The Boss of the Eighth, D., 2000....
RELIANCE—The Badge of Office, D.....

Thursday, October 8, 1914.

DOMINO—The Whiskey Runners, D., 2000.....
KEYSTONE—Hello Mabel, C., 1000.....
MUTUAL WEEKLY—No. 93.....

Friday, October 9, 1914.

KAY-BEE—The Sheriff of Muscatine, D., 2000....
PRINCESS—The One Who Cared, D.....
THANHOUSER—Benevolence of Conductor 786, C

Saturday, October 10, 1914.

KEYSTONE—Those Love Pangs, C., 1000.....
RELIANCE—The Tardy Canon Ball, D., 2000.....
ROYAL—The Pet of the Petticoats, C.....

Sunday, October 11, 1914.

KOMIC—Bill Spoils a Vacation (No. 8), C.....
MAJESTIC—The Sands of Fate, D., 2000.....
THANHOUSER—The Rescue, D.....

RELEASES OF NEXT WEEK

Monday, October 12, 1914.

AMERICAN—Jail Birds, D., 2000.....
KEYSTONE—The Anglers.....
RELIANCE—Our Mutual Girl No. 39.....

Tuesday, October 13, 1914.

BEAUTY—Winsome Winnie, C.....
MAJESTIC—The Warning, D.....
THANHAUSER—The Diamond Disaster, D., 2000..

Wednesday, October 14, 1914.

AMERICAN—Down by the Sea, D.....
BRONCHO—The End of the Galley, D., 2000....
RELIANCE—Bad Man Mason, D.....

Thursday, October 15, 1914.

DOMINO—Jimmy, D., 2000.....
KEYSTONE—High Spots on Broadway, C., 1000..
MUTUAL WEEKLY—No. 94.....

Friday, October 16, 1914.

KAY BEE—The Word of His People, D., 2000....
PRINCESS—The Touch of a Little Hand, D.....
MAJESTIC—Back to the Kitchen, C.....

Saturday, October 17, 1914.

KEYSTONE—Dash, Love and Splash and Santa
Catalina Islands, Split Reel

RELIANCE—The Revenue Officer's Deputy, D.,
2000

ROYAL—The Black Hand, C.....

Sunday, October 18, 1914.

KOMIC—Dizzy Joe's Career, C.....
MAJESTIC—For His Father's Sins, D., 2000....
THANHOUSER—Left in the Train, C.....

High Praise for Thomas H. Ince

Appreciative New York Motion Picture Company Fan Writes from Mississippi of the Delights of Kay-Bee and Broncho Films

A LETTER from a pleased patron cannot help make a producer feel that his efforts to entertain the public have been successful. It is gratifying for him to know that all the skill he brings to bear on his work is appreciated by those who sit before the screen and watch the results of his labors.

Thomas H. Ince, of the New York Motion Picture Corporation, was recently the recipient of such a communication from an admirer of his pictures, living in Meridian, Miss.

So impressed was the writer that he addressed Mr. Ince as "king of all directors and producers," certainly a tribute to the stage management of the New York Motion Picture director.

A letter of this character carries with it a peculiar feeling of gratification inasmuch as the sentiments expressed indicate the right attitude toward photo plays. This patron, whose feelings are typical of thousands of other picture fans, considers motion pictures a vital and necessary form of entertainment.

His attitude is indicative of the tendency to consider film drama an important, if not the most important form of amusement today, demanding anybody's serious attention.

Consequently, everything—the acting, the settings, the plot, in short, all that must receive a producer's minute scrutiny to get the best result—is keenly observed by motion picture patrons.

The letter follows:

T. H. INCE, ESQ.

DEAR SIR:—Kindly permit me to express my sincere thanks and heartfelt gratitude to you for your peerless work in behalf of the amusement-loving public. My chief regret is that I cannot find words to express myself to you.

Nor could I, if I were a master of languages. Really, you are a benefactor. Your photo dramas are faultless and incomparable; absolutely without a flaw. How on earth can you pick such versatile artists, like Shorty Hamilton, the Aridville terror, or the gentleman that played the above role; and Thad Channing, the wonderful fellow in "Jim Regan's Last Raid"?

What a delight to the eye it is to see Clara Williams and your entire aggregation of world-beaters. I can, too, understand it all upon second thought. You are a genius. It's indeed a treat to see a Broncho and Keystone. Never did I, and I never will, see such excellent acting as that of Shorty and his associates; never was I so thrilled as I was when I saw the productions from

your brains; viz., "Her Father's Story," "Shorty Gets Into Trouble," and "Shorty Turns Judge."

I am sorry that the exhibitor here gets but one two-reel Broncho feature once a week, instead of almost every day. I've been in Meridian nearly three months, and have seen only one Kay Bee. Now, that's another good company.

It is not my intention to annoy a busy man such as yourself. But I would consider it a favor to learn the address of the versatile Shorty, the artist that portrayed the role of Thad Channing, the saloon proprietor, the bandit known as "The Desert Rat"; and Clara Williams, who had the lead in "Jim Regan's Last Raid"; and the female star in "The Tong-Fued."

How can it be arranged to have a larger number of Bronchos shown here, as I have heard scores of other photo drama patrons speak in the highest terms of the Ince Bronchos.

Sincerely,

ALBERT HARTMAN.

Sixth Street and Twenty-fifth Avenue, Meridian, Miss.

BUYS A MOTIOGRAPH

Fred McCoy, of Eldon, Mo., has just purchased a new projecting machine for his theatre, the latest model motiograph, with motor attachment.

ACTUAL WAR FILMS

are coming to hand in London. You must have them post-haste. Only selected films purchased. Can recommend.

German Occupation Louvain.....\$63.40
Germans Entering Brussels.....\$34.82
Ruins of Yemonde.....\$30.84

WAR FILMS OF THE MOMENT.

Servian Army.....\$45.52
Indian Army.....\$55.00
Japanese Army.....\$45.52
British Navy.....\$60.24
British Cavalry.....\$47.24
Italian Navy and Army.....\$64.64
Also Other Nations' Sea and Land Forces.
Above Prices Inclusive of Reg. Letter Post.

THE LATEST WAR FILMS DISPATCHED AS RECEIVED.

Terms—Cash only, draft, or your bank's cable order for payment against invoice on London Bank.

HIRAM HORTON, FILM BROKERS,
ARTOGRAGH HOUSE,
8 NEW CROMPTON ST., LONDON, W. C.
BANKERS: LLOYDS' BANK,
Oxford St., London.

Your negative developed, printed and titled complete

5c delivered 12 hours
per foot within
Titles 6c per foot

GUNBY BROS., Inc.
145 West 45th Street New York City

There is a Big Advantage

In getting The News each week. It enables you to know what is going on in film circles throughout the country. Wise exhibitors turn this knowledge into money.

"ACT QUICKLY"
STATE RIGHTS NOW SELLING
RELEASED OCT. 15

BEULAH POYNTER
IN
"LENA RIVERS"

IN FIVE PARTS

Book NOW from Your Exchange

COSMOS FEATURE FILM CORPORATION
126 WEST 46TH STREET, NEW YORK

HEADQUARTERS FOR POWERS, MOTIOGRAPH, SIMPLEX AND EDISON MACHINES

PICTURE THEATRE EQUIPMENT CO.

THE BIGGEST MOTION PICTURE SUPPLY HOUSE IN AMERICA

21 EAST 14th STREET, NEW YORK CITY

CONDENSERS—BOOTHS—TICKET CHOPPERS—REELS—REEL CASES—BOOTH CABINETS

WE EQUIP MOTION PICTURE THEATRES COMPLETELY

RELEASE DATES FOR READY REFERENCE

GENERAL FILM PROGRAM

BIOGRAPH

10— 5. The Borrowed Book, D.....1000
 10— 6. Gwendolin, D.....2000
 10— 8. Their Little Drudge, D.....1000
 10— 9. They Were College Boys, C..... 496
 The Man Hunters, C..... 503
 10—10. His Mother's Home, D..... 999
 10—12. The Guiding Fate, D.....1004
 10—13. The Iron Master, D.....2017
 10—15. The First Law, D..... 1000
 10—16. Peg o' the Wild Wood, D.....1000
 10—17. Meeting Mr. Jones, C..... 469
 Our Home-Made Army, C..... 532

COLUMBUS

10— 8. The New Apprentice, C..... 750
 Kissing Germ, C..... 250
 10—13. Why Snakeville Went Dry, C.....1000

EDISON

10— 3. A Transplanted Prairie Flower, D.1000
 10— 5. Father's Beard, C.....1000
 10— 6. Greater Love Hath No Man, D.1000
 10— 7. Seth's Sweetheart, C.....1000
 10— 9. The Long Way, D.....2000
 10—10. A Fragment of Ash, D.....1000
 10—12. Buster Brown's Education, C..... 500
 George Washington Jones, C..... 500
 10—13. The Letter That Never Came Out, D.1000
 10—14. Andy and the Redskins, C.....1000
 10—16. On the Isle of Sarne, C.....2000
 10—17. The Case of the Banished Bonds, D.1000
 10—19. The Adventures of the Smuggled Diamonds, D.....1000
 10—20. The Man in the Dark, D.....1000
 10—21. Two's Company, C.....1000
 10—23. Bootles' Baby, D.....2000
 10—24. Buster Brown's Uncle, C..... 500
 A Question of Clothes, C..... 500
 10—26. Wood B. Wedd and the Microbes, C.1000
 10—27. The Mystery of the Sealed Art Gallery, D.....1000
 10—28. The Lost Melody, D.....1000
 10—30. The Midnight Ride of Paul Revere, D.....2000
 10—31. The Hand of Iron, D.....1000

ESSANAY

10— 2. Golf Champion "Chick" Evans Links with Sweedie, C.....2000
 10— 3. Broncho Billy Trapped, D.....1000
 10— 5. The Fickleness of Sweedie, C.....1000
 10— 6. The Verdict, D.....1000
 10— 7. The Fable of "The Family That Did Too Much for Nellie," C.1000
 10— 8. When Slippery Slim Met the Champion, C.1000
 10— 9. The Real Agatha, D.....2000
 10—10. Broncho Billy and the Greaser, D.1000
 10—12. Sweedie Learns to Swim, C.....1000
 10—13. Through Eyes of Love, D.....1000
 10—14. The Fable of "The Author and the Dear Public and the Plate of Mush, C.1000
 10—15. Snakeville's Peace-Maker, C.....1000
 10—16. The Other Man, D.....2000
 10—17. Broncho Billy Rewarded, D.....1000

KALEM

10— 6. For the Love of Mike, C..... 8000
 Hesanut Hunts Kild Game, C..... 200
 10— 7. The Lost Mail Sack, D.....2000
 10— 9. The Tattered Duke, C.....1000
 10—10. Fate's Midnight Hour, D.....1000
 10—12. The Girl and the Stowaway, Alice Joyce Series, C..... 2 parts
 10—13. Percy Pimpernickel—Soubrette, C.1000
 10—14. Seed and the Harvest, D.....2000
 10—16. St's Wonderful Mineral Spring, C.1000
 10—17. From Peril to Peril, D.....1000
 10—19. The Mad Mountaineer, D.....1800
 Hesanut Buys an Auto, Cartoon.. 200
 10—20. A Wise Rube, C.....1000
 10—21. The False Guardian, D.....1000
 10—23. Micky Flynn's Escapade, C.....1000
 10—24. The Demon of the Rails, D.....1000
 10—26. The Lynbrook Tragedy, Alice Joyce Series, D.....2 parts

10—27. The No-Account Count, C.....1000
 10—28. The Menace of Fate, D.....2 parts
 10—30. Ham and the Villain Factory, C.1000
 10—31. The Vengeance of Winona, D.....1000

KLEINE

9—29. A Shot from Ambush, D.....2000
 10— 6. The Wrecked Special, D.....2000
 10—13. On the Battle Line, D.....2000

LUBIN

10— 6. Wife's Athletic Mamma, C..... 400
 A Hunting Absurdity, C..... 600
 10— 7. The Girl at the Lock, D.....2000
 10— 8. In Old Virginia, D.....2000
 10— 9. The Green-Eyed Monster, D.....1000
 10—10. When the Ham Turned, C.....1000
 10—12. The Girl from the West, the Beloved Adventure Series No. 5, D.1000
 10—13. Swami Sam, D..... 400
 Neighborly Neighbors, C..... 600
 10—14. The Bond of Womanhood, D.....2000
 10—15. The Imposter, D.....2000
 10—16. The Long Lane, D.....1000
 10—17. The Smuggler's Daughter, C.....1000
 10—19. The Golden Hope, the Beloved Advertiser No. 6, D.....1000

SELIG

9—30. The Loyalty of Jumbo, D.....1000
 10— 1. Hearst-Selig News Pictorial No. 62, N.1000
 10— 2. An Embarrassing Predicament, C.1000
 10— 3. Four Minutes Late, D.....1000
 10— 5. The Moving Picture Cowboy, C.....2000
 10— 5. Hearst-Selig News Pictorial No. 63, N.1000
 10— 6. The Way of the Redman, D.....1000
 10— 7. The Reparation, D.....1000
 10— 8. Hearst-Selig News Pictorial No. 64, N.1000
 10— 9. Jimmie, the Porter, C..... 500
 Doc Yak's Bottle, C..... 500
 10—10. Her Victory Eternal, D.....1000
 10—12. The Dream Girl, D.....2000
 Hearst-Selig News Pictorial No. 65, N.1000
 10—13. The Mexican, D.....1000
 10—14. The Mysterious Beauty, C.....1000
 10—15. Hearst-Selig News Pictorial, No. 66, N.1000
 10—16. The Man-Hater, C.....1000
 10—17. The Woman of It, D.....1000

RELEASE DAYS

GENERAL FILM PROGRAM

Monday—Biograph, Edison, Hearst-Selig News Pictorial, Kalem, Pathé, Selig, Vitagraph.
 Tuesday—Edison, Essanay, Geo. Kleine, Pathé, Lubin, Melies, Selig, Vitagraph.
 Wednesday—Edison, Essanay, Kalem, Lubin, Melies, Selig, Pathé, Vitagraph.
 Thursday—Biograph, Essanay, Hearst-Selig News Pictorial, Lubin, Melies, Pathé, Selig, Vitagraph.
 Friday—Edison, Essanay, Kalem, Selig, Pathé, Lubin, Vitagraph.
 Saturday—Biograph, Edison, Essanay, Kalem, Lubin, Pathé, Vitagraph, Selig.

UNIVERSAL PROGRAM

Monday—Victor, Imp, Powers.
 Tuesday—Gold Seal, Crystal, Universal Ike.
 Wednesday—Nestor, Joker, Eclair, Animated Weekly.
 Thursday—Imp, Rex, Frontier, Sterling.
 Friday—Nestor, Powers, Victor.
 Saturday—Joker, Frontier, 101 Bison.
 Sunday—Rex, Crystal, Eclair.

MUTUAL PROGRAM

Monday—American, Keystone, Reliance.
 Tuesday—Beauty, Majestic, Thanouser.
 Wednesday—American, Broncho, Reliance.
 Thursday—Dominio, Keystone, Mutual Weekly.
 Friday—Kay-Bee, Majestic, Princess.
 Saturday—Keystone, Reliance, Royal.
 Sunday—Majestic, Komic, Thanouser.

10—20. Such a Mess, C..... 400
 Only Skin Deep, C..... 600
 10—21. The Hopeless Game, D.....2000
 10—22. Her Mother Was a Lady, D.....2000
 10—23. The Girl in the Tenement, D.....1000
 10—24. The Crooks, C.....1000
 10—26. "The Holdup," the Adventurer Series, No. 7, D.....1000
 10—27. Love and Title, C..... 400
 She Married for Love, C..... 600
 10—28. The Mountain Law, D.....2000
 10—29. The Wolf's Daughter, D.....2000
 10—30. Thumb Prints and Diamonds, D.1000
 10—31. The Soubrette and the Simp, C. 400
 An Interrupted Nap, C..... 600

MELIES

9—15. The Tramp's Revenge, C.....1000
 9—17. The Scab Waiter, C.....1000
 9—22. The \$1,000 Pants, C.....1000
 9—24. How Clarence Got His, C.....1000
 9—29. A Circus Romance, C..... 900
 10— 1. Blind Marriage, C.....1000

PATHE

8—24. Edible Fishes of the English Channel, E. 550
 Picturesque Normandy, France, T. . . 500

VITAGRAPH

10— 7. Kill or Cure, C.....1000
 10— 8. The Loan Shark King, D.....1000
 10— 9. Josie's Legacy, C.....1000
 10—10. The Rose and the Thorn, D.....2000
 10—12. Midst Woodland Shadows, Idyl.1000
 10—13. Marcea, the Foster-Mother, D.....2000
 10—14. The Peacemaker, C.....1000
 10—15. His Dominant Passion, D.....1000
 10—16. Fatty's Sweetheart, C.....1000
 10—17. The Girl in the Case, D.....2000
 10—19. His Wedded Wife, D.....1000
 10—20. Anne of the Mines, D.....2000
 10—21. Under False Colors, C.....1000
 10—22. The Mill of Life, D.....1000
 10—23. A Custume Piece, C.....1000
 10—24. Good-bye Summer, D.....2000
 10—26. The Cave Dwellers, C.....1000
 10—27. Underneath the Paint, D.....2000
 10—28. William Henry Jones' Courtship, C.1000
 10—29. Kidding the Boss, C.....1000
 10—30. Bunny Backslides, C.....1000
 10—31. Within an Ace, D.....2000

UNIVERSAL PROGRAM

ANIMATED WEEKLY

9—30. Animated Weekly No. 133, News..
 101 BISON
 10— 3. Love and Baseball, C.....2000
 10—10. The Phantom Light, D.....2000
 10—17. Monsieur Bluebeard, D.....2000
 10—24. My Lady Raffles in "The Mysterious Hand," D.....3000

CRYSTAL

9—28. Charlie's Smoke, and Belmont Butts In, C.
 10— 6. Liferitis, C.....
 10—13. Oh, You Gypsy Girl and Some Collector, C.....
 10—20. Vivian's Transformation, C.....

ECLAIR

9—30. Till the Sands of the Desert Grow Cold, D.2000
 10— 7. The Line Rider, D.....2000
 10—11. Cupid Victor, C.....1000
 10—18. The Quarrel, D.....
 10—24. The Squatter, D.....3000
 10—21. The Vicar, D.....2000
 10—25. Smallpox on the Circle U, D.....

No matter how thrilling a story one may read, interest is not sustained if poor type, poor paper and poor press work make hard work for the eyes. It's the same with motion pictures. A clear picture is as necessary as a good scenario.

Because the basic product is right, the clearest pictures are on "Eastman" film. Look for the stencil mark in the margin.

EASTMAN KODAK CO.,
ROCHESTER, N. Y.

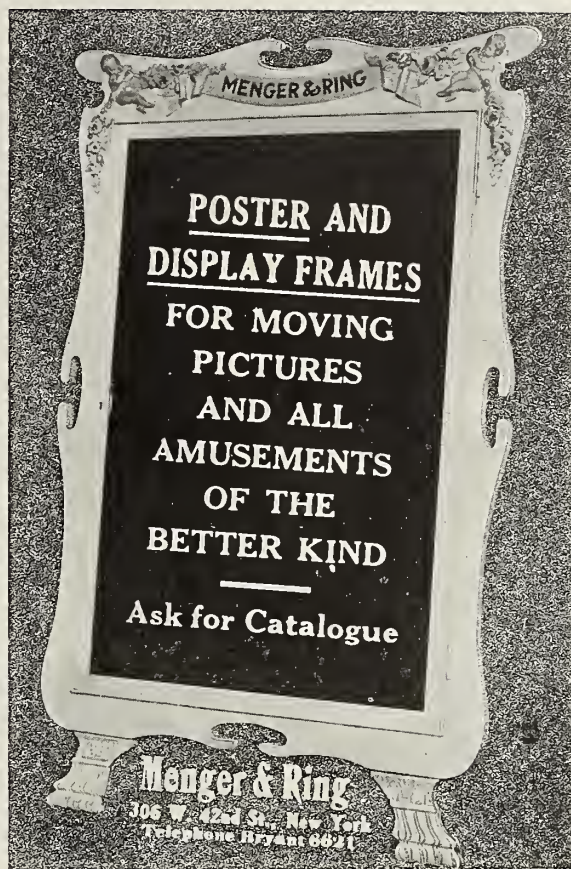

TITLES

Our *Title Department* has been re-organized, elaborately equipped and placed under the direction of recognized experts.

Its highly perfected apparatus, linotype machine and job presses enable us to produce the most difficult title work in any language—artistically, accurately and *quickly*—and at *lower prices* than have ever yet been quoted.

DEVELOPING AND PRINTING

Save money and insure the best results by entrusting your work to the *largest and most complete commercial plant in America.*

CENTAUR
FILM CO.

Bayonne, N. J., and 1600 Broadway, N. Y.

The Show That Draws The Biggest Crowds—

Quality of pictures presented rather than the length of the show, brings people regularly to your doors. Even the best films are greatly improved in their clearness and detail when projected through

Bausch^{and} Lomb Projection Lenses

A remarkable clearness to the very corners and even illumination result from the use of Bausch & Lomb objectives which are computed scientifically with the requirements of moving picture projection especially in mind.

Regularly supplied with Edison and Nicholas Power machines and procurable at all exchanges.

Send for our interesting free booklet for owners and operators.

Bausch & Lomb Optical Co.
569 ST. PAUL STREET ROCHESTER, N. Y.

RELEASE DATES FOR READY REFERENCE—Continued

FRONTIER

- 9—27. The Man in the Attic, D.....
 10—4. Four Days, D.....
 10—11. Dolly's Deliverance, D.....
 10—18. In the Hollow of an Oak, D.....
 10—24. The Scarecrow's Secret, D.....

GOLD SEAL

- 10—6. The Trey O' Hearts, Episode No. 10, D.....2000
 10—13. The Trey O' Hearts, Episode No. 11, D.....2000
 10—20. Trey O' Hearts, Episode No. 12, D.....2000

IMP

- 9—24. Universal Boy, The Newsboy's Friend, D.....
 9—28. The Dark Horse, Mary Pickford Reissue, D.....
 10—1. The Tenth Commandment, D.....3000
 10—5. Shadows, D.....2000
 10—8. Universal Boy in "Rural Adventures," D.....
 10—12. Mary's Convert, Reissue, D.....
 10—15. The Futility of Revenge, D.....2000
 10—19. Country Innocence, D.....2000
 10—22. Universal Boy in "The Gates of Liberty".....

JOKER

- 9—23. The Statuesque Beauty, and Jane's Lovers, split reel.....
 9—30. The New Butler, C.....
 10—3. In the Clutches of the Villain, C.....
 10—7. The Baseball Fan in Fanville, C.....
 10—10. Cruel, Cruel World, C.....
 10—14. On Again, Off Again, Finnigan, C.....
 10—17. Across the Court, C.....
 10—21. The Countess Count, C.....

L-KO

- 10—25. Love and Surgery, C.....2000

NESTOR

- 9—4. The Baby Did It, C.....
 9—9. A Daughter of the Plains, D.....
 9—11. Feeding the Kitty, C.....
 9—16. The Danger Line, D.....
 9—18. The Troublesome Wink, C.....
 9—23. The Half Breed, D.....
 9—25. Fruits and Flowers, C.....
 9—30. The White Wolf, D.....
 10—2. Out of the Frying Pan, C.....
 10—7. The Old Bell Ringer, D.....
 10—9. He Never Said a Word, C.....
 10—16. The Way of Life, D.....

POWERS

- 9—18. A Modern Melnotte, D.....2000
 9—25. The Actress, D.....
 10—2. The Actress, D.....
 10—9. The Mayor's Manicure, C.....
 10—16. The Padrone's Ward, D.....2000
 10—23. Suspended Sentence, C.....

REX

- 9—20. A Prince of Bavaria, C.....
 9—24. Little Sister, D.....
 9—27. As the Wind Blows, D.....2000
 10—1. The Boob's Legacy.....
 10—4. A Law Unto Herself, D.....2000
 10—8. A Law Unto Herself, D.....2000
 10—11. Virtue Its Own Reward, D.....2000
 10—15. Her Life's Story, D.....
 10—18. Kid Regan's Hands, D.....2000
 10—22. Olaf Erickson—Boss, D.....2000
 10—25. The Little Blond Lady, D.....

STERLING

- 10—8. Hypnotic Power, C.....
 10—12. The Close Call, C.....
 10—15. Heine's Outing, C.....
 10—19. The Mistaken Bath House, C.....
 10—22. Secret Service Snitz, C.....

UNIVERSAL IKE

- 10—6. The Neglected Wife.....
 10—13. Mary Green's Husband, and Educational, C.....
 10—13. Mary Green's Husband, and The Monkey Cabaret, C., split reel..

VICTOR

- 9—28. The Proof of a Man, D.....
 10—2. The Rock of Hope, D.....2000
 10—5. Disillusioned, D.....
 10—9. The Woman Who Won, C.....
 10—12. His Father's Son, D.....2000
 10—16. The Funny Mr. Dingle, C.....
 10—19. Rice Industry in the U. S. E.....
 10—23. The Bride of Marble Head, D.....2000

MUTUAL FILM PROGRAM

AMERICAN

- 9—30. The Brothers.....
 10—5. Daphnia.....
 10—7. Billy's Rival.....
 10—12. Jail Birds, D.....2000
 10—14. The Fisherman's Daughter, D.....1000
 10—19. In the Daylight, D.....2000
 10—21. In the Open, D.....1000
 10—23. The Final Impulse, D.....1000

BEAUTY

- 9—22. Caught in a Tight Pinch.....
 9—29. The Legend of Black Rock.....
 10—6. Niede, D.....1000
 10—13. Winsome Winnie, C.....1000
 10—20. Dad and the Girls, C.....1000

BRONCHO

- 10—7. The Boss of the 8th.....
 10—14. End of the Galley.....
 10—21. Shorty and Sherlock Holmes.....
 10—28. The Golden Goose.....

DOMINO

- 9—24. The Test of Flame.....
 10—1. The Gamekeeper's Daughter.....
 10—8. The Whiskey Runners.....
 10—15. Jimmy.....
 10—22. The Power of the Angelus.....
 10—29. Eric the Red's Wooing.....
 11—5. In Old Italy.....

KAY-BEE

- 9—25. The Death Mask.....
 10—2. One of the Discard.....
 10—9. The Sheriff of Muscatine.....2000
 10—16. The Word of His People.....2000
 10—23. The Spark Eternal.....2000
 10—30. The Worth of a Life.....

KEYSTONE

- 8—24. Fatty's Gift.....
 8—27. The Masquerader.....
 8—29. Her Last Chance.....
 8—31. His New Profession.....
 9—3. The Baggage Smasher.....
 9—5. A Brand New Hero.....
 9—7. The Rounders.....
 9—10. Mabel's Latest Prank.....
 9—12. Mabel's Blunder, C.....
 9—14. All at Sea, C.....
 9—17. Bombs and Bangs, C.....
 9—19. Lover's Luck, C.....
 9—21. He Loved the Ladies, C.....1000
 9—24. The New Janitor, C.....1000
 9—28. Hard Cider, C.....1000
 10—1. Killing Horace, C.....1000
 10—3. Fatty Again, C.....1000
 10—5. Their Ups and Downs, C.....1000
 10—8. Hello Mabel, C.....1000
 10—10. Those Love Pangs, C.....1000
 10—12. Anglers, C.....1000
 10—15. High Spots on Broadway, C.....1000
 10—17. Dash, Love and Splash, and Santa Catalina Islands, split reel.....

KOMIC

- 9—13. Bill Goes in Business for Himself (No. 6).....
 9—20. Foiled Again.....
 9—27. Bill Manages a Prize-Fighter (No. 7)
 10—4. The Million Dollar Bride.....
 10—11. Bill Spoils a Vacation, (No. 8), C.
 10—18. Dizzy Joe's Career.....

MAJESTIC

- 9—22. Meg of the Mines.....
 9—27. The Great God Fear.....
 9—29. A Mother's Trust.....
 10—4. Out of the Air.....
 10—6. The Unpainted Portrait.....
 10—11. The Sands of Fate, D.....2000
 10—13. The Warning.....
 10—16. Back to the Kitchen.....
 10—18. For Her Father's Sins.....2000
 10—20. Environment.....
 10—25. Paid with Interest.....2000
 10—27. A Mother's Influence.....
 11—1. Paid with Interest.....

MUTUAL WEEKLY

- 9—3. No. 88.....
 9—10. No. 89.....
 10—17. No. 90.....
 10—24. No. 91.....
 11—1. No. 92.....
 11—8. No. 93.....
 11—15. No. 94.....

PRINCESS

- 9—4. His Winning Way.....
 9—11. Sis.....
 9—18. The Master Hand.....
 9—25. The Balance of Power.....
 10—2. The Balance of Power.....
 10—9. The One Who Cared, D.....
 10—16. The Touch of a Little Hand.....

RELIANCE

- 9—23. The Last Shot.....
 9—26. The Runaway Freight.....
 9—28. Our Mutual Girl No. 37.....
 9—30. When the Mountains Meet.....
 10—2. The Sheriff's Master.....
 10—3. The Wireless Voice.....
 10—5. Our Mutual Girl, No. 38.....
 10—7. The Badge of Office.....
 10—10. The Tardy Canon Ball.....2000
 10—12. Our Mutual Girl (No. 39).....
 10—14. Bad Man Mason.....
 10—17. The Revenue Officer's Deputy.....2000
 10—19. Our Mutual Girl (40).....
 10—21. Out of the Deputy's Hands.....
 10—24. A Blotted Page.....2000
 10—26. Our Mutual Girl No. 41.....
 10—30. The Availing Prayer.....

ROYAL

- 9—12. The Prodigal Husband.....
 9—19. The Horse Trader.....
 9—26. Scarecrow.....
 10—3. Cousin Bill.....
 10—10. The Pet of the Petticoats.....
 10—17. The Black Hand.....

THANHOUSEER

- 9—1. A Mother's Choice.....2000
 9—6. Little Mischief.....
 9—8. Jean of the Wilderness.....2000
 9—11. In Danger's Hour.....
 9—13. The Emperor's Spy.....
 9—15. Gold.....
 9—20. The Mettle of a Man.....
 9—22. The Varsity Race.....
 9—27. The Harvest of Regrets.....
 9—29. The Trail of the Love Lorn.....
 10—4. A Dog's Love.....
 10—6. The Cripple.....
 10—9. The Benevolence of Conductor 786.....
 10—11. The Rescue.....
 10—13. The Diamond of Disaster.....2000
 10—18. Left in the Train.....
 10—20. Old Jackson's Girl.....2000
 10—25. Mr. Cinderella.....
 10—27. A Madonna of the Poor.....2000

LUBIN

THE PRODUCER OF MASTERPIECES
EVERY EXHIBITOR SHOULD BOOK THESE EXCEPTIONAL FEATURES
 (Through the General Film Special Service)

WILLIAM ELLIOTT, Late Star of "Madame X"
 Company

"THE FORTUNE HUNTER"
 6 Reels By Winchell Smith Produced by Barry O'Neil

"MARAH THE PYTHONESS"
 3 Reels By Clay M. Greene Produced by Joseph W. Smiley

READY FOR EARLY RELEASE
EVELYN NESBIT THAW
 and her son, **RUSSELL WILLIAM THAW** in
"THREADS OF DESTINY"

5 Reels By William H. Clifford Produced by Joseph W. Smiley

EDWIN ARDEN

5 Reels **"EAGLE'S NEST"** Produced by
 By Edwin Arden Romaine Fielding

RAYMOND HITCHCOCK In a 5 Reel Comedy Drama
 by Lawrence McCloskey
 Produced by George Terwilliger

"STONEWALL JACKSON'S WAY"
 3 Reels By Emmett Campbell Hall Produced by Edgar Jones

IN PREPARATION
ROSE COGLAN
 And **ETHEL CLAYTON** in
"THE SPORTING DUCHESS"
 6 Reels By Cecil Raleigh Produced by Barry O'Neil

SIX REGULAR RELEASES EACH WEEK

- "THE BELOVED ADVENTURER," 5th of Series "The Girl From the West,"—Drama..... Monday, October 12th.
- "SWAMI SAM,"
- "NEIGHBORLY NEIGHBORS," } Split Reel Comedies..... Tuesday, October 13th.
- "THE BOND OF WOMANHOOD,"—Two Reel Drama..... Wednesday, October 14th.
- "THE IMPOSTER,"—Two Reel Drama..... Thursday, October 15th.
- "THE LONG LANE,"—Drama..... Friday, October 16th.
- "THE SMUGGLER'S DAUGHTER,"—Comedy..... Saturday, October 17th.

SPECIAL ONE, THREE AND SIX SHEET POSTERS.

Lubin Manufacturing Company, Philadelphia, Pa.

Chicago Office:
 154 West Lake Street



YOUR DRAWING POWER IS MULTIPLIED MANY TIMES WHEN MOTIOGRAPHS ARE INSTALLED

Rock Steady
 Pictures
 with
 Small-Upkeep

Ask the
 Many
 Thousand
 Users

The
**ENTERPRISE
 OPTICAL MFG.
 CO.**

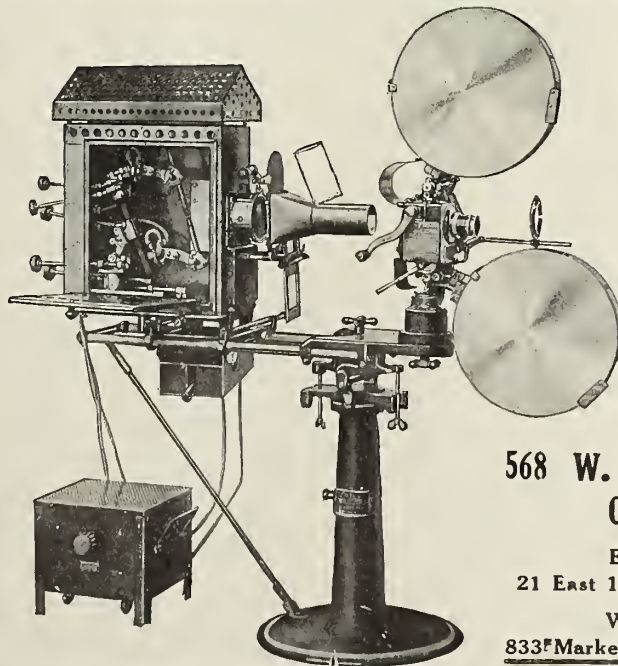

568 W. RANDOLPH STREET
 CHICAGO, ILL.

EASTERN OFFICE
 21 East 14th Street, New York, N. Y.

WESTERN OFFICE
 833¹/₂ Market Street, San Francisco, Cal.

RELEASE DATES FOR READY REFERENCE—Continued

FEATURE RELEASES

ALCO FILM CORPORATION

ALL STAR

10—5. The Nightingale, D.....5 parts
10—19. The Shore Acres.....

CALIFORNIA MOTION PICTURE CORP.

11—2. Salomy Jane.....5 parts

FAVORITE PLAYERS

10—19. The Key to Yesterday, D.....4 parts

POPULAR PLAYS AND PLAYERS

10—12. The Ragged Earl, D.....
10—26. Michael Strogoff, D.....5 parts

APEX

Sept. Queen of the Counterfeiters, D..4 parts
Oct. Called to the Front; or Europe at War, D.....3 parts

BOX OFFICE ATTRACTIONS

9—21. Will o' the Wisp, D.....4 parts
9—28. Fighting the World, D.....5 parts
9—28. The Square Triangle, D.....3 parts

COSMOS FEATURE FILM CORPORATION

10—15. Lena Rivers, D.....

COSMOFOTOFILM CORPORATION

Aug. What a Woman Will Do, D.....4 parts
Sept. England's Menace, D.....3 parts
Oct. England Expects—, D.....

HEPWORTH-AMERICAN

Aug. The Girl from the Sky, C.....
8—29. The Chimes, D.....3 parts
The Terror of the Air, D.....2 parts
Sept. Creatures of Clay, D.....3 parts

HECTOR FILM CORPORATION

Sept. Born Again, D.....5 parts

GEORGE KLEINE

Sept. Spartacus, D.....8 parts
Sept. Vendetta, D.....5 parts
Sept. The Lion of Venice, D.....6 parts

LIFE PHOTO FILM CORPORATION

Sept. Captain Swift, D.....5 parts
Oct. The Ordeal, D.....5 parts

ECLECTIC FILM COMPANY

Max Has the Boxing Fever, C.... 560
Picturesque Lake Dahl, British India, Scenic 400
In Soak, C.....
A Prince of India, D.....
Pathé Daily News No. 64-1914, Top. Second Door Left, C.....
Pathé Daily News No. 65, Top....
Perils of Pauline, No. 14, D.....
Colonel Heeza Liar in the Wilderness, C..... 700
Strange Animals, E..... 300
Pathé Daily News No. 62-1914, Top.
The Colonel's Wife, D.....
Pathé Daily News No. 63-1914, Top.
War Stricken Louvain, Topical....

PARAMOUNT PICTURES

BOSWORTH

9—14. Burning Daylight.....5 parts
10—1. Pursuit of the Phantom.....5 parts
10—19. Hypocrites!.....4 parts

FAMOUS PLAYERS

9—21. Such a Little Queen.....5 parts
10—5. Marta of the Lowlands.....5 parts
10—15. Wildflower.....4 parts
10—26. The County Chairman.....5 parts
10—29. His Last Dollar.....4 parts

JESSE LASKY COMPANY

9—17. Bobby Burnit.....4 parts
10—12. What's His Name.....
10—22. Where the Trail Divides.....5 parts

PLAYGOERS FILM COMPANY

Oct. The Great Diamond Robbery, D..6 parts

PICTURE PLAYHOUSE FILM COMPANY, INC.

8—10. The Oath of a Viking.....3000
8—19. The Next in Command.....4000
8—26. The Film Detective.....4000
9—5. The Mystery of the Poison Pool, D.....5 parts
9—10. Desperado of Panama, D.....3 parts
9—17. Lure of the Yukon, D.....3 parts

RENOWNED PLAYERS

Sept. A Great Mistake, D.....5 parts

SAWYER, INCORPORATED

Sept. Tyranny of the Mad Czar, D.....4 parts
Sept. Doc, D.....4 parts
Oct. Thirty Minutes in Melodrama, C..2 parts
Oct. The Factory Magdalen, D.....4 parts
Oct. The Volunteer Parson, D.....4 parts
Oct. The Detective Queen, D.....4 parts

WARNER'S FEATURES

Sept. When We Were Young, D.....
Sept. The Arrow's Tongue, D.....
Sept. Alone in New York, D.....5 parts
Sept. The Price of Crime, D.....3 parts
Oct. Iluned Down, D.....
Oct. In the Duke's Power, D.....
Oct. Bess of the Blazing Sea, D.....
Oct. The Adventures of Kitty Cobb, D.....

WORLD FILM CORPORATION

9—14. Protea II, D.....5 parts
9—21. The Dollar Mark, D.....5 parts
9—28. Mother, D.....4 parts
The Man in the Cellar, D.....

ANIMATED SONGS

Imperial Motion Picture Co., New York
Latest Releases:

A Fool There Was.
Take Me Back to Frisco Town.
Shadows.
Father Came Home with the Milkman in the Morning.
Dear Old Girl.
What a Wonderful Love That Would Be.
When I Dream of Killarney.
Down in Our Old Country Town.
In the Valley of the Moon.
Let's Go Back to Sweetheart Days.
Just a Black Sheep That Strayed from the Fold.
Let Us Kiss and Make Up Again.
There's a Lonesome Little Girl in a Lonesome Little Town.
She Was My Dad's First Sweetheart.
Down Where the Old Road Turns.
Push It Along.
She's Just a Bird in a Gilded Cage.

STATEMENT OF THE OWNERSHIP, MANAGEMENT, CIRCULATION, ETC., required by the Act of August 24, 1912, of MOTION PICTURE NEWS, published weekly at New York, N. Y., for October 1, 1914.

Editor, William A. Johnston, 220 West Forty-second street, New York; managing editor, Lesley Mason, 220 West Forty-second street, New York; business manager, H. Ashton Wyckoff, 220 West Forty-second street, New York; publisher, Exhibitors' Times, Inc., 220 West Forty-second street, New York.

Owners (If a corporation, give its name and the names and addresses of stockholders holding 1 per cent. or more of total amount of stock. If not a corporation, give names and addresses of individual owners.): Exhibitors' Times, Inc., 220 West Forty-second street, New York; William A. Johnston, 220 West Forty-second street, New York; H. Ashton Wyckoff, 220 West Forty-second street, New York; Henry F. Sewall, 220 West Forty-second street, New York; P. S. Alden, 220 West Forty-second street, New York; Wentworth Tucker, 220 West Forty-second street, New York; Carl Tucker, 220 West Forty-second street, New York.

Known bondholders, mortgagees, and other security holders, holding 1 per cent. or more of total amount of bonds, mortgages, or other securities (If there are none, so state.): None.

Average number of copies of each issue of this publication sold or distributed, through

the mails or otherwise, to paid subscribers during the six months preceding the date shown above. (This information is required from daily newspapers only.) Weekly magazine.

(Signed) H. ASHTON WYCKOFF,
Business Manager.

Sworn to and subscribed before me this 10th day of September, 1914.

(Seal) ADA M. RILEY,
Certificate filed in New York County, No. 3323.

Certificate filed in Register's Office, New York County, No. 6177.

(My commission expires March, 1916.)

HEARD IN THE LOBBIES

The Buffalo *Sunday Times* announces that it will start a contest whereby local school children can get Pathescopes for their schools. Coming as it does after the Buffalo *Sunday News* announcement, there are those who wonder thereat.

"Neptune's Daughter," which was shown at the Brandeis Theatre, in Omaha, recently, has been booked for a return engagement. It made a decided hit there.

Beverly Bayne, who wore jewels of great value in the Essanay production "Under Royal Patronage," made her own wedding gown,

which she wore in the picture. She spent about a week on the garment, and it is said it looked like the imported variety.

Margaret Joselin, the truly comical comedienne in Essanay's Snakeville comedies, has adapted the latest style in hair dressing to her own person. In "Snakeville's Most Popular Lady" she appears in "split curls," and they are plenty large enough to be noticed.

Ben Turpin, of the Essanay Comedy Company, has a mule which he is teaching to count. The mule's front feet, however, are being trained for this purpose. The comedian has a mysterious respect for the animal's posterior propellers.

Maurice Costello, the popular Vitagraph star, was recently in Pittsburgh and took part in the Labor Day parade. He was visiting at the home of his parents on Forbes street. He made the rounds of the film exchanges and was accorded a hearty welcome from his friends.

Shafer and Irwin, proprietors of the Acme theatre in Barnesville, O., are getting the Universal service from Pittsburgh instead of Cleveland. There is a plan being worked out by this system whereby the service will be improved for several of the Ohio towns.

John Papulius, of the Olympic theatre at Steubenville, O., was in Pittsburgh several days ago looking up features for his theatre. He now uses the Paramount pictures in addition to the Universal schedule.

KAY-BEE

K

E

Y

S

T

O

N

E

KAY-BEE

One Two-Part Photoplay a Week

Friday, Oct. 16—The Word of His People.
Friday, Oct. 23—The Spark Eternal.
Friday, Oct. 30—The Worth of a Life.

KEYSTONE

Three a Week

Monday, Oct. 12—The Anglers.
Thursday, Oct. 15—High Spots on Broadway.
Saturday, Oct. 17—Zip, the Dodger.
Monday, Oct. 19—Dash, Love and Splash—Santa Catalina Islands.
The Keystone Co. in the very near future will release a multiple reel comedy every other week in addition to the regular releases.

BRONCHO

One Two-Part Photoplay a Week

Wednesday, Oct. 14—The End of the Galley.
Wednesday, Oct. 21—Shorty and Sherlock Holmes.
Wednesday, Oct. 28—The Golden Goose.

DOMINO

One Two-Part Photoplay a Week

Thursday, Oct. 15—Jimmy.
Thursday, Oct. 22—The Power of the Angelus.
Thursday, Oct. 29—Eric the Red's Wooing.

Released Exclusively Through the Mutual Film Corporation

PENNANTS—Beautiful bright colored pennants of the four brands can be had by sending to the PUBLICITY DEPT. 35 cents for one, \$1.25 for set of four.

PHOTOS—8 x 10 photos of our players can be had by sending to the PUBLICITY DEPT. 15 cents for one, 50 cents for set of four, \$1.00 for set of eight.

Keystone Mabel in Four Poses 50 Cents

New York Motion Picture Corporation

FORTY-SECOND STREET and BROADWAY, Longacre Building, NEW YORK

B

R

O

N

C

H

O

DOMINO

Our Factory Is Yours!

Negative assemblers, projecting machines and an equipment second to none, with an organization of experienced people always at your SERVICE for DEVELOPING and PRINTING.

EVANS FILM MFG. CO.

Incorporated
416-22 WEST 216th STREET
Tel. 7652 Audubon at Broadway, New York

STERLING Motion Picture CAMERA

Price No. 2.....\$350
Including Instruction.

This is a practical Professional Camera fitted with Zeiss Tessar Lens, patent adjustable dissolving shutter and aperture plate operated from outside of camera case, equipped with 4-500 ft. magazine.

STERLING CAMERA & FILM CO.
145 W. 45th St., New York City, N. Y.
Bryant 8064

FURNITURE & FURNISHINGS

On RENTAL
We equip your settings complete in accordance with your scenario.

WILLIAM BIRNS
103-105 West 37th St.
Phone: Greeley 6255.

LANG'S FILM REELS

THE BEST MADE
14 in. \$1.50 10 in. \$1.00
CATALOGUE
LANG MFG. WORKS, Orleans, N. Y.

Lantern Slide Mat Co.

Manufacturers of
Lantern Slide Mats and
Reel Bands

Prompt Service Prices Right Best Goods

149 W. 35th St., New York
Telephone: Greeley 6414

A. L. Runyon Advertising & Sales Co., Inc., Successors to



Prices to The Trade
POSITIVE PRINTS .04 1/2 Per Foot
(In Quantities over 5000 feet)
Above price includes printing, developing, tinting, toning and Raw Positive
Negative Film Developed .01 Per Ft.
Film Titles .08 " " "
(Our Special Title Apparatus will match any perforation.) All work guaranteed.
General Offices, 2624 Milwaukee Ave., Chicago
Phone Albany 3125

ARTISTIC POSTERS FOR WORLD FILM

The World Film Corporation has determined to get up printing that will have a different note than that usually found in lithograph paper. It has secured the exclusive services of W. N. Wilson, the famous magazine illustrator and poster expert. Mr. Selznick is determined that the printing used by the World Film Corporation in advertising its releases shall be the finest available, and without sparing expense upon this new department of which Mr. Wilson is to be the head.

Mr. Wilson has studied in England, Paris and Berlin, and was for many years a poster expert for the largest lithographing establishment in England. He himself is a specialist in the German poster style, and has a wonderful sense of grouping and of contrast. Several of Mr. Wilson's animal paintings have been exhibited in the salons of the Continental capitals.

This is a distinct step forward in the development of the poster in this connection with the advertisement of motion pictures, but it is in keeping with the progressive policy of the World Film Corporation.

BUSHMAN AND THE JEALOUS(?) HUSBAND

Francis X. Bushman, who is starring in Essanay's four act production, "The Slim Princess," received a letter recently from a man in Mississippi who wishes to fight a duel with the hero.

It is said that the man said his wife is infatuated with the film star and spends her time looking at his photograph and visiting theatres where Mr. Bushman appears on the screen. The husband is aware of the fact that his wife has never seen Mr. Bushman personally, but thinks it his duty to challenge him to a duel.

LITTLE MISS TODD HAS A BIRTHDAY PARTY

An elaborate birthday party was given the other afternoon by Mr. and Mrs. Harry Todd of the Western Essanay company at Niles, Cal., in honor of their little daughter, Margaret, on her eleventh birthday.

Covers were laid for eleven. Over the festive board hung a huge Kewpie with yellow streamers fluttering down to eleven small Kewpies, one at each plate. Many valuable presents were received by Margaret, among them a gold pin, the gift of G. M. Anderson.

PORTRAITS OF GARWOOD IN JEWELER'S WINDOW

William Garwood, of the Flying A studios, has been signally honored by a jeweler in Santa Barbara, Cal., who has made a display of the actor's portraits in the window. The collection gives an idea of the many parts he has played, for here we see William as he is, both flattered and otherwise, as an old man, a boy, a clergyman, a crook, joyous, in despair, in dramatic and comedy roles.

Moving Picture Scenarios

We are in the market for one and two reel comedies and comedy dramas.

Submit in typewritten form to

J. C. BROWNELL

105 Lawrence Avenue Dorchester, Mass.

Holland Film Manufacturing Co.

"New Film For Old"



Films Improved, Cleansed and Softened

Multicolor Film Improving Co., Inc.
15 East 26th Street New York
Philadelphia Branch Albert Teitl President
1126 Vine Street

THE CORCORAN RACK IS THE BEST EVER

Get No. 6 Price List

A. J. CORCORAN, INC.

9 1/2 John Street New York

PRINTING, DEVELOPING AND FILM TITLES

All Work Guaranteed—Prompt Service.
We can furnish an expert camera man if you have some special event to be photographed. Our prices are right. A trial will convince you.

STANDARD MOTION PICTURE CO.
Tel. Randolph 839 5 S. Wabash Av., Chicago

LE COURRIER

Cinematographique

28 Boulevard St. Denis, Paris

Directeur: Charles LE FRAPER

Journal hebdomadaire français, le plus important de l'industrie cinématographique.

Envoie numéro spécimen, sur demande.
Abonnement 12 FR. 50

THE CHEAPEST PLACE

TO BUY BEST QUALITY

ROLL TICKETS

IS

The Pioneer Ticket Co.

722 Broadway, New York

Perfect Numbering Quick Delivery

SOMETHING NEW

In Posters

3-Sheets for 1-Reel Pictures

Many exhibitors are using today expensive and inferior states right pictures simply because they receive with them elaborate **three** and **six-sheet posters**. In answer to the many requests for **three-sheet posters of Universal single reels**, the MORGAN LITHOGRAPH CO., is now getting out, **three-sheet posters** on six or eight of the best single reel releases on the regular

UNIVERSAL PROGRAM

EACH WEEK

Order them from your exchange and get the benefit of the wonderful single reel releases which **your patrons want**, and the big advertising display which **you need**.

The MORGAN LITHOGRAPH CO., has also provided beautiful **six-color war posters** to go with the

European War Views

which are now being released by the Universal, and a wonderful **War Map** which you will do well to **order at once from the exchange** which serves you or direct from the

MORGAN LITHOGRAPH CO., Cleveland, Ohio

OR THE

Service Department

THE Universal Film Company

1600 Broadway

CARL LAEMMLE, Pres.

New York



EDISON



BOOTLE'S BABY

By JOHN STRANGE WINTER

A Dramatic Adaptation
of the Celebrated Novel
by the Same Name

Thoroughly at a loss to account for the feeling, all of Gilchrist's companions felt a certain restraint whenever he came around. Broody and melancholy, he diffused an air of gloom that was very depressing. Gilchrist's life had become embittered by an unhappy marriage and despite the fact that his wife and child were in want, he had thrown them both off with contempt.

Grace Gilchrist made one last appeal, and then realizing that she would have to make her way in the world, decided to impress Gilchrist with his responsibility by leaving the baby girl for him to care for. She crept into his quarters and left the sleeping child on his bed, pinning a note on her sleeve saying that he would have to provide for her until she could secure a position.

How the baby became the care of a comrade "Bootles" and how he eventually proposed to Grace is the most interesting part of the plot.

In two parts. 2,000 ft. To be released Friday, Oct. 23rd

COMING EDISON RELEASES

Mon.	Oct.	19—THE ADVENTURE OF THE SMUGGLED DIAMONDS.....	1,000 ft.	Drama
Tues.	"	20—THE MAN IN THE DARK	1,000 "	Drama
Wed.	"	21—TWO'S COMPANY	1,000 "	Comedy
Fri.	"	23—BOOTLE'S BABY	2,000 "	Drama
Sat.	"	24—BUSTER BROWN'S UNCLE	500 "	Comedy
		A QUESTION OF CLOTHES	500 "	Comedy

TWO GREAT EDISON SUCCESSES

"THE LONG WAY," a three-part reel just released. A masterpiece of dramatic production. Scenic and photographic effects are very beautiful.

"MY FRIEND FROM INDIA," another masterpiece in which Walter E. Perkins is in the title role. To be obtained through the General Film Company's special releases. Full of laughs.

Order Edison Posters of the Morgan Lithograph Co., Cleveland, Ohio, direct



TRADE MARK
Thomas A Edison
Makers of the Edison Kinetoscope,
Model "D"

THOMAS A. EDISON, Inc.
275 Lakeside Avenue, Orange, N. J.



OCTOBER 24, 1914

Motion Picture News

HAS THE QUALITY CIRCULATION OF THE TRADE

PARAMOUNT PICTURES

JESSE L. LASKY

PRESENTS
GEORGE BARR McCUTCHEN'S
ROMANCE OF STAGE LIFE

"WHAT'S HIS NAME"

WITH
MAX FIGMAN

5 PARTS RELEASED OCTOBER 22D 300 SCENES

JESSE L. LASKY FEATURE
PLAY CO.

JESSE L. LASKY SAMUEL GOLDFISH CECIL B. DE MILLE
PRES. TREAS. & GEN. MGR. DIR. GEN'L.



THE TREACY HEARTS

BY LOUIS JOSEPH VANCE

THE MASTER PROBLEM PLAY
IN FIFTEEN STORIES

FEATURING
CLEO MADISON & GEO LARKIN
PRODUCED BY WILFRED LUCAS

UNIVERSAL
STORY THIRTEEN

PARAMOUNT

PICTURES

DANIEL FROHMAN

Presents

MARY PICKFORD

In the noted play of theatrical life



“BEHIND THE SCENES”

By Margaret Mayo, Author of "BABY NINE"

A fascinating play that contrasts the drama of life with the glamor of the footlights.

IN FIVE PARTS

RELEASED OCTOBER 26 TH.

PRODUCED BY THE

FAMOUS PLAYERS FILM CO

ADOLPH ZUKOR, President,

DANIEL FROHMAN, Managing Director EDWIN S. PORTER, Technical Director

Executive Offices,

213-229 W. 26TH STREET, NEW YORK.

36
FAMOUS
FEATURES
A YEAR

36
FAMOUS
FEATURES
A YEAR

A CHANGE *of* HEART

Two-reel Wharton-made American Drama. In which a man with the right start in life goes wrong, and how a chance reminder starts him struggling up again. The story of an elaborate confidence game which succeeds only to fail through the awakening of a man's better nature. Natural emotional scenes which appeal to all who have ever been tempted or duped. A taking, gripping drama with a highly artistic climax. Featuring Thurlow Bergen. 1-3-6 sheet posters.



Colonel Heeza Liar (Naturalist)

The Colonel, that funniest of film characters, by the inimitable cartoonist, J. R. Bray, is still experiencing tropical adventures of a most extraordinary nature; throughout he's a perfect fountain of laughter. This time he is combined with

KATSURA RIVER (Picturesque Japan)

Fascinating scenic views in natural colors.

The Poor Little Rich Boy

1 reel American Mayo-made comedy. A big entertainment for little people and big people, too. The story of a boy whose training didn't fit him for the baseball diamond. That doesn't stop his dreaming, however, and after all an imaginary home run is almost as much fun as the real thing.

The World Without Men

Three-part comedy-drama. Three bachelor girls, sworn man-haters, find it hard to let that fascinating sex alone. They find it even harder, however, to acknowledge to each other their true attitudes. Anyone who doesn't laugh at this film must have an ache somewhere.

The Perils of Pauline

There is no need to go into details about Pauline. Everyone who has ever seen a motion picture knows her by now and is wild about her. We would like to say, however, that she is keeping ahead of her records in former releases, which is like making a home run on top of a three-bagger.

PAULINE'S PROFITS ARE ONLY

EXCELLED BY PAULINE'S DARING

The Eclectic Film Co.



110 West 40th Street,
New York City

"The Cream of American and European Studios."

ATLANTA
61 Walton St.
BOSTON
3 Tremont Row
CHICAGO
5 So. Wabash Ave.
CINCINNATI
217 E. 5th St.
CLEVELAND
622 Prospect Av., S. E.
DALLAS
Andrews Bldg.
DENVER
Nassau Bldg.

KANSAS CITY
928 Main St.
LOS ANGELES
114 E. 7th St.
MINNEAPOLIS
4th and Hennepin Sts.
NEW ORLEANS
910 Gravier St.
NEW YORK
115 E. 23rd St.
OMAHA
1312 Farnam St.
PHILADELPHIA
1235 Vine St.
PITTSBURGH
715 Liberty Ave.

PORTLAND
392 Burnside Ave.
SALT LAKE CITY
68 South Main St.
SAN FRANCISCO
67 Turk St.
SEATTLE
810 Third Ave.
ST. LOUIS
3210 Locust St.
SYRACUSE
214 E. Fayette St.
WASHINGTON,
7th & E Sts., N. W.

MASTERPIECE FILMS

MASTERPIECE FILMS

MR. MAX FIGMAN

Supported by

MISS LOLITA ROBERTSON

in

"THE HOOSIER SCHOOLMASTER"

(FIVE REELS)

By **EDWARD EGGLESTON**

RELEASED OCTOBER 22

Write or wire for reservations

Attractive paper consisting of three one-sheet, two three-sheet, one six-sheet and one twenty-four-sheet.



Aside from "Uncle Tom's Cabin" and "Les Miserables," "The Hoosier Schoolmaster" is probably more widely read by the American public than any other novel.

The production of the film version of this work is thoroughly in keeping with the greatness of the subject.

M. DE LA PARELLE, Producer
ELLIOTT J. CLAWSON, Assistant Producer

Address all communications to

MASTERPIECE FILM MANUFACTURING CO.

1111 Van Nuys Building, Los Angeles, Cal.

MASTERPIECE FILMS

MASTERPIECE FILMS



Startling—vivid—gripping—dramatic
The HYPNOTIC VIOLINIST

A woman under the mystic spell of a gypsy musician.
Impossible feats made possible by mesmeric power.
A big 3-part feature. Book it now.

WARNER'S FEATURES, Inc., New York

THE 42 Exchanges of Warner's Features, Inc., offer Exhibitors unequaled booking facilities. During the last three months the number of Warner's Exchanges has been doubled. This was necessitated by the tremendous growth of the business and the addition of our new

FEATURE and COMEDY PROGRAM

Such rapid expansion has been the result of the stamp of unqualified approval placed upon Warner's Features by Exhibitors throughout the country.

Atlanta, Ga.	Edmonton, Can.	Philadelphia, Pa.
Baltimore, Md.	El Paso, Texas	Pittsburgh, Pa.
Boston, Mass.	Indianapolis, Ind.	Portland, Me.
Buffalo, N. Y.	Kansas City, Mo.	Portland, Ore.
Calgary, Can.	Los Angeles, Cal.	San Antonio, Texas
Cleveland, Ohio	Louisville, Ky.	San Francisco, Cal.
Charlotte, N. C.	Minneapolis, Minn.	St. Louis, Mo.
Chicago, Ill.	Montreal, Can.	Seattle, Wash.
Charleston, W. Va.	Nashville, Tenn.	Spokane, Wash.
Cincinnati, Ohio	Newark, N. J.	Syracuse, N. Y.
Dallas, Texas	New Orleans, La.	Toronto, Can.
Denver, Colo.	New York City	Washington, D. C.
Des Moines, Iowa	Omaha, Neb.	Wilkes Barre, Pa.
Detroit, Mich.		Winnipeg, Can.

Main European Office: 99 Charing Cross Road, London, W. C.

Write to the nearest Exchange for news of the latest Warner's releases

WARNER'S FEATURES, Inc., New York



EDISON

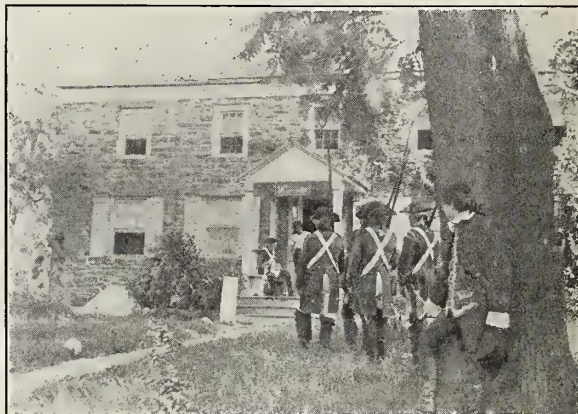

THE MIDNIGHT RIDE OF PAUL REVERE

Retold After the Famous Poem by Henry W. Longfellow

Of all the characters of our Revolutionary period, none is more endeared to young and old than that of Paul Revere, whose exploit has been immortalized by Longfellow so effectively that the lines of the poem and the incidents portrayed are graven more deeply, perhaps, upon the average American mind than any other character or exploit of our American history.

The action throughout this film is finely sustained and many of the scenes, including Revere's house, that of Hancock, the wall at Lexington, where the first shots were fired, were all taken on the exact historical spots where the original action took place.

This is a film that will stir the hearts and minds of young and old, and should be met with a tremendous welcome throughout the entire country.

2,000 feet. To be released Friday, Oct. 30th

COMING EDISON RELEASES

Mon.	Oct. 26th	—Wood B. Wedd and the Microbes.....	Comedy	1,000 ft.
Tues.	" 27th	—The Mystery of the Sealed Art Gallery.....	Drama	1,000 "
Wed.	" 28th	—The Lost Melody	Drama	1,000 "
Fri.	" 30th	—The Midnight Ride of Paul Revere.....	Drama	2,000 "
Sat.	" 31st	—The Hand of Iron.....	Drama	1,000 "

TWO GREAT EDISON SUCCESSES

"THE LONG WAY," a three-part reel just released. A masterpiece of dramatic production. Scenic and photographic effects are very beautiful.

"MY FRIEND FROM INDIA," another masterpiece in which Walter E. Perkins is in the title role. To be obtained through the General Film Company's special releases. Full of laughs.

Order Edison Posters of the Morgan Lithograph Co., Cleveland, Ohio, direct



TRADE MARK
Thomas A Edison
Makers of the Edison Kinetoscope,
Model "D"

THOMAS A. EDISON, Inc.

275 Lakeside Avenue, Orange, N. J.



SPECIAL FEATURES

General Film Company

TITLE	MAKE	No. of Reels	TITLE	MAKE	No. of Reels
THIRD DEGREE	Lubin	5	IN DEFIANCE OF LAW	Selig	3
THOR, LORD OF JUNGLE	Selig	3	A KINGDOM AT STAKE	Kleine	3
THE BATTLE OF SHILOH	Lubin	4	CAPTAIN ALVAREZ	Vitagraph	6
THE LION AND THE MOUSE	Lubin	6	OTHELLO	Kleine	5
THROUGH FIRE TO FORTUNE	Lubin	5	SHANNON OF SIXTH	Kalem	5
JUDITH OF BETHULIA	Biograph	4	MAN'S ENEMY	K. & E. Biograph	3
GERMINAL	Pathe	5	IN TUNE WITH THE WILD	Selig	3
LOST IN MID OCEAN	Vitagraph	3	THE WOLF	Lubin	6
A ROMANY SPY	Pathe	3	SHADOWS OF THE PAST	Vitagraph	3
A CELEBRATED CASE	Kalem	4	MR. BINGLES' MELODRAMA	Vitagraph	3
THE FULFILLMENT	Essanay	3	MEN AND WOMEN	K. & E. Biograph	3
NIGHT RIDERS OF PETERSHAM	Vitagraph	3	THE SECRET OF RING	Kleine	3
HARDING'S HERITAGE	Pathe	3	MY FRIEND FROM INDIA	Edison	3
DAUGHTERS OF MEN	Lubin	5	LIBERTY BELLES	K. & E. Biograph	3
THE OTHER HALF OF THE NOTE	Kalem	3	THE ERRING	Lubin	3
HER LADYSHIP	Selig	3	AMBUSHED	Essanay	3
GOODNESS GRACIOUS	Vitagraph	3	SONG OF THE SOUL	Kleine	3
OFFICER JIM	Lubin	3	KIT, THE ARKANSAS TRAVELER	Kalem	3
DEATH SIGN AT HIGH NOON	Kalem	3	CHIP OF THE FLYING "U"	Selig	3
GAME OF LIFE	Selig	3	FAIR REBEL	K. & E. Biograph	3
THE MILITANT SUFFRAGETTE	Pathe	5	HOUSE NEXT DOOR	Lubin	5
FRANCIS MARION, "THE SWAMP FOX"	Kalem	3	MY OFFICIAL WIFE	Vitagraph	5
A MILLION BID	Vitagraph	5	UNCLE BILL	Vitagraph	3
THE FATAL WEDDING	K. & E. Biograph	3	THE FORTUNE HUNTER	Lubin	6
THE GAMBLERS	Lubin	5	THE VENDETTA	Kleine	5
ANNE BOLEYN	Kleine	3	BAREFOOT BOY	Kalem	3
STRUGGLE FOR LIFE	Pathe	5	THE WIFE	K. & E.	3
MONGREL AND MASTER	Essanay	3	KING OF CHANCE	Kalem	3
THE ROYAL BOX	Selig	4	THE WAGES OF SIN	K. & E.	3
THE CURSE OF CREED	Melies	5	THE PLUM TREE	Essanay	3
FACING THE FOOTLIGHTS	Pathe	3	THE FIFTH MAN	Selig	3
BLOOD WILL TELL	Essanay	3	THE GOLDEN BEETLE	Kleine	4
CONQUEST OF QUEBEC	Kalem	5	THE WEIGHT OF A CROWN	Lubin	3
THE LILY OF THE VALLEY	Selig	3	MARAH, THE PYTHONESS	Lubin	3
CLASSMATES	K. & E. Biograph	4	CHARITY BALL	K. & E. Biograph	3
MAN OF THE HOUR	Selig	3	HEARTS AND MASKS	Selig	3
MR. BARNES OF NEW YORK	Vitagraph	6	A FLORIDA ENCHANTMENT	Vitagraph	5
LOVE, LUCK AND GASOLINE	Vitagraph	3	ROAD TO YESTERDAY	K. & E. Biograph	3
THE BILLIONAIRE	K. & E. Biograph	3	THE PAINTED WORLD	Vitagraph	3
SPORT AND TRAVEL IN AFRICA	Pathe	5	JUDGE NOT	Kleine	4
THE GOOD FOR NOTHING	Essanay	4	GARRISON'S FINISH	Selig	3
THE BOER WAR	Kalem	5	POWER OF THE PRESS	K. & E. Biograph	4
THE THUMB PRINT	Melies	4	IN THE GLARE OF LIGHTS	Essanay	3
STRONGHEART	K. & E. Biograph	3	THE RED CROSS NURSE	Melies	3
LORD CHUMLEY	K. & E. Biograph	4	THE THREADS OF DESTINY	Lubin	5
SEVEN DAYS	K. & E. Biograph	3	WHEN THE LIONS ESCAPE	Melies	3
TREASURE OF ABDAR RAHMAN	Pathe	4	THE GENIUS	K. & E. Biograph	3
'NEATH THE LION'S PAW	Melies	3	STONEWALL JACKSON'S WAY	Lubin	3
ONE WONDERFUL NIGHT	Essanay	4	THE INVISIBLE WAY	Kalem	4
WOMAN AGAINST WOMAN	K. & E. Biograph	3	THE WOMAN IN BLACK	K. & E. Biograph	4
			UNDER THE GASLIGHT	K. & E. Biograph	4

SENSATIONAL! BAFFL

A Thrilling Drama of Love, Science and Hindu

Thanhouser's Great

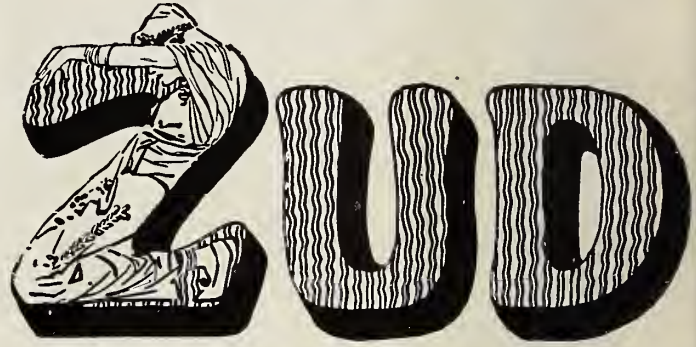

Created by Daniel Carson Goodman

The New Thanhouser Serial to Follow
the Million Dollar Mystery.

A mammoth production of 20 thrilling
episodes — 150 scenes to each episode —
3,000 scenes in all—*more scenes than in all
the plays of Shakespeare.*

A two-reel episode will be released each

Exhibitors:

Zudora will be an independent
release and may be obtained re-
gardless of the regular program
being used. Bookings are now
being arranged by the Than-
houser Syndicate Corporation
whose representatives may be

THANHOUSER SYNDI

71 W. 23d Street
Produced

THANHOUSER FILM
New Rochelle.

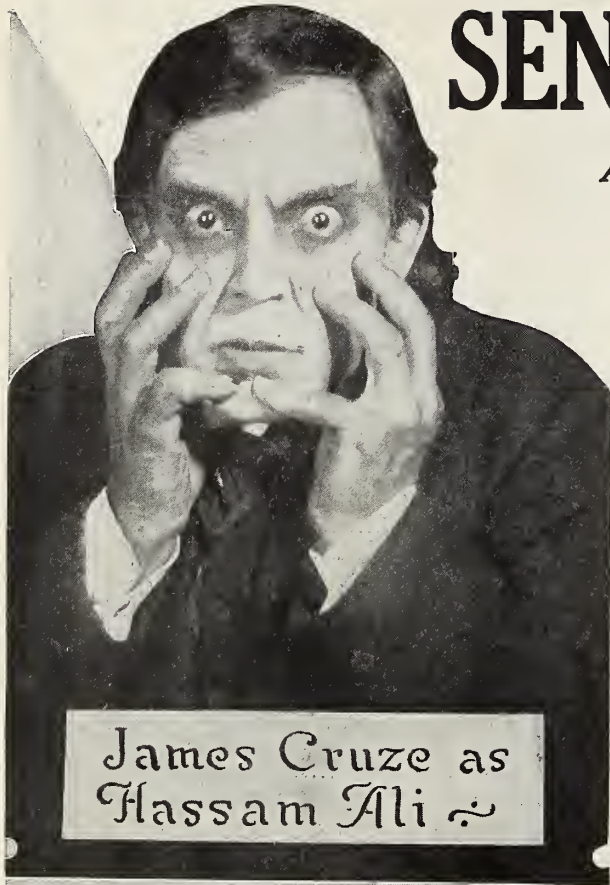

James Cruze as
Hassam Ali



Hassam Ali
Crystal Gazer and Seer

ING!! STUPENDOUS!!!

Mysticism Played by a Cast of 1000 People

est Photoplay

ZUDORA

Novelized by Harold MacGrath

week starting Monday, November 23.

Story to appear in the Chicago Tribune and 500 other leading newspapers.

A play written by noted authors, enacted by stars — positively the biggest attraction ever brought out!



Marguerite Snow
as Zudora

Attention!

found at any Mutual Exchange in the United States or Canada.

Go to the nearest Mutual office at once and see the Thanhauser Syndicate representative for full information about ZUDORA. Or wire or write and details will be sent you.



Zudora Solving the Mystery of the Spotted Collar ~

ATE CORPORATION

New York City

ORPORATION



ALCO



"The Ragged Earl"

Popular Plays and Players Company Picturize Andrew Mack in His Famous Comedy-Drama.

Reviewed by the Rev. E. Boudinot Stockton, S.T.B.

FOR clean, pure comedy-drama, of the highest educational character we have seen nothing to compare with "The Ragged Earl" as made by Lubin for the Popular Plays and Players Company. It represents a type of photodrama that for the past five years we have been trying to convince manufacturers, directors and photoplaywrights is not only the kind that the American people want, but is also the kind that will increase the bank account of all concerned. It is a typical example of educational comedy or of "pure food" as compared with the "adulterated candy" entertainment that is so common nowadays. Give us more of it.

As to the acting, Andrew Mack, who plays his old role of Gerald Fitzgerald; Earl of Kildare, the ragged earl, has achieved as great, if not greater, success before the eye of the camera as he did formerly in the eyes of thousands of legitimate theatergoers, and he is most ably supported by the cast with which Lubin has supplied him. William Conklin as Sir Henry Hardcastle is excellent; Edward J. Peil as Lord Wildbrook, the old roue who wishes to marry Kathleen, is inimitable and Ormi Hawley and Eleanor Dunn as the two stepchildren of Sir Henry are simply superb. So also is the actress whose name should have been listed in the cast who played the part of Lady Hardcastle.

Another thing deserving comment is the settings and locations. The interiors are not only in keeping with the character of the story, but they also coincide with the exteriors, a point that is apparently almost always, to judge from what we see, overlooked or paid little attention to by nearly every director. Fairmount Park, the Wisahickon Drive, and the Lancaster Turnpike offer some of the most beautiful exteriors that can be found anywhere in the world and, judging from the locations, we recognized in the picture these and similar localities have been utilized for all they are worth by a director who had a discerning mind.

"THE NIGHTINGALE"

Drama in Five Reels. Written by Augustus Thomas. Produced by the All-Star Feature Corporation.

The delicate art of building a play around a player has been practised with varying success by a sufficient number of dramatists, though not, in recent years at least, by Augustus Thomas. As a playwright, he has given every indication of believing that the play comes first and that the players are there to give it expression; but as a photo-playwright, he is willing to reverse the order. Evidently the determined purpose of the All-Star Company was to find a story in which Ethel Barrymore had every opportunity, and Mr. Thomas set himself the task of devising such a story in preference to adapting a play that was essentially of and for the stage. Altogether, a wise move, for "Mid-Channel," "Tank," or any one of the subtle dramas acted by Miss Barrymore, probably would have made a sorry showing on the screen. As it is, audiences will find a stage star meeting motion picture actresses on their own ground, so to speak, and giving a beautiful performance in a quite typical photoplay story.

It is a good one, in that it affords Miss Barrymore a wide scope and permits a variety of moods seldom attainable in a strict adaptation of a play kept consistently in one key and progressing along the lines of a definite theme. Few actresses have had equal opportunities to do themselves justice when facing the camera for the first time; so it is only fair to say that Mr. Thomas achieved something well worth doing when he wrote "The Nightingale." Taking a good picture is a natural quality very much in Miss Barrymore's favor, but her playing of Isola Franti is much more than a series of pretty posturings. She shows an exceptional aptitude for making her meaning clear and giving the ring of truth to a character. Isola is an Italian girl, and whether in good fortune or ill, clothed in calico or silk, Miss Barrymore preserves the same little oddities of manner that are as thoroughly a part of the character's individuality as is physical appearance.

ALCO

ALCO FILM

ALCO BUILDING, 218 WEST



NEXT RELEASE—Monday, Oct. 19

The Eminent Tragedian of the Contemporary Stage

Jacob P. Adler in Jules Verne's Immortal Classic

“MICHAEL STROGOFF”

Produced by

The Popular Plays & Players Company in 5 Reels — 274 Scenes



TO BE RELEASED OCT. 26

The All Star Feature Corporation

Presents JAMES A. HERNE'S MASTERPIECE

“SHORE ACRES”

with

Chas. A. Stevenson as “Nat”

Coming Nov. 2nd, “SALOMY JANE” with BEATRIZ MICHELENA

SECURE BOOKINGS FROM THE NEAREST ALCO EXCHANGE

ALCO FILM CORPORATION OF NEW ENGLAND 162 Tremont Street, Boston, Mass.

For Maine, New Hampshire, Vermont, Rhode Island, Massachusetts, Connecticut.

ALCO FILM SERVICE 327 St. Paul Street, Baltimore, Md.

For Delaware, Maryland, District of Columbia, Virginia.

ALCO FILM SERVICE 512 Mallery Bldg. (5 So. Wabash Ave.) Chicago, Ills.

For Illinois and Indiana.

NEW YORK ALCO FILM EXCHANGE 218 West 42nd Street, New York City.

ALCO FILM SERVICE 234 Eddy Street, San Francisco, Cal. For California, Nevada, Arizona.

ALCO FILM SERVICE Temple Court Building, Minneapolis, Minn. For Wisconsin, Minn., North and South Dakota.

ALCO FILM SERVICE 212 Fourth Avenue, Pittsburgh, Pa. For Western Pennsylvania, Ohio, Kentucky, W. Virginia.

ALCO FILM SERVICE 1331 Vine Street, Philadelphia, Pa. For New Jersey and Eastern Pa.

ALCO FILM SERVICE OF MISSOURI New Grand Central Theatre, Grand and Lucas Aves., St. Louis, Missouri.

For Missouri, Kansas, Iowa, Nebraska.

ALCO FILM SERVICE 27 West Park St., Butte, Montana.

ALCO FILM SERVICE 1902 Commerce Street, Dallas, Texas. For Oklahoma and Arkansas.

ALCO FILM SERVICE 710 Northwestern Bank Bldg., Portland, Oregon.

ALCO FILM SERVICE 1214 Third Avenue, Seattle, Washington.

ALCO FILM SERVICE 911 Trent Ave., Spokane, Washington.

ALCO FILM SERVICE 607 Broad Street, Newark, N. J.

ALCO FILM SERVICE 514 West 9th Street, Los Angeles, Cal.



CORPORATION

2ND STREET, NEW YORK CITY





Thanhouser's Million Dollar Motion Picture Production

THE MILLION DOLLAR MYSTERY

Story by Harold MacGrath

Scenario by Lloyd Lonergan

Episode No. 18 of The Million Dollar Mystery has just been released. It contains *new* thrills—*new* action—and is keenly interesting. It puts another wedge in the tremendous popularity of this picture. All 18 episodes are now available for bookings.

\$10,000.00 will be paid for the best 100-word solution of the mystery. 300 leading newspapers are now running this story. Exhibitors may arrange bookings by applying *at once* to

Syndicate Film Corporation

71 West 23rd Street, New York Room 411, 5 S. Wabash Avenue, Chicago
or Syndicate Film Corporation Representative at any Mutual Exchange in the United States or Canada

The Thanhouser Three-a-Week

Tuesday, October 20th. "Old Jackson's Girl."

This is a two-reel Western drama that throbs with emotion—excitement. It depicts an episode from the life of Jim Jackson—a suspected horse thief—whose daughter is in love with a young ranchman. The thrills which are exhibited before the young couple is finally united, make this an exceptionally interesting photoplay. Note this excellent cast: Dave Thompson, Mayre Hall, Morris Foster, Justus D. Barnes, Clare Kroell, E. Sherwood and Jack Sullivan.

Sunday, October 25th. "Mr. Cinderella."

A beautiful playlet based on the fairy tale idea. How little Jimmie—the poor, pitted boy—is given an opportunity by his fairy godfather to visit the county fair and meet the Queen of the Popcorn Trust and enjoy himself immensely, is an interesting film story. The cast includes Nolan Gane, Fan Bourke, E. Turner, J. Myers, Dave Thompson and Mildred Heller.

Thanhouser Film Corporation

New Rochelle, N. Y.

Head European Office, Thanhouser Films, Ltd., London, W. C., England
Regular Thanhouser releases are distributed exclusively in the United States and Canada
by the Mutual Film Corporation.

50



OCT 27 1914

"When You See It
In 'The News'
It's NEWS"

Motion Picture News

HAS THE QUALITY CIRCULATION OF THE TRADE

"The Exhibitors'
Medium of
Communication"

Tel. 7650 Bryant

NO. 220 WEST FORTY-SECOND STREET

New York City

Volume X

OCTOBER 24, 1914

Number 16

Advertising as a Sales Agent

AN experienced writer who is preparing for a leading publication a series of six articles on motion pictures has already evolved an apt simile for the industry.

He calls it a "Klondyke."

This immediately suggests the average magazine writer's superficial viewpoint—and the absurd impressions he conveys—that most picture manufacturers and many exhibitors are millionaires, and that motion picture riches are easy, quick and abundant.

These articles, by the way, have done, and will continue to do, the industry more harm than almost any one agency.

* * *

BUT this particular writer is investigative and analytical. He says the business was a "Klondyke" several years ago.

It was then possible to stick a spade in the ground and strike rich pay dirt.

Today the industry is like every big gold field after its discovery era. It is being worked systematically. Greater successes than ever are to be had, but now only through carefully organized effort.

* * *

THE motion picture industry of today is like the Klondyke of today.

The producing end is becoming more and more systematized.

Labor efficiency, quality production, purchasing foresight, cost accounting—these are taking the place of haphazard and wasteful methods. The exhibiting business is getting down to rock-bottom basis of any retail business, wherein enterprise and economy are the deciding factors in competition.

* * *

MOST important of all because it has been most neglected, *the selling end of the film business is becoming organized and standardized.*

The old business maxim, that it is easier to produce than to sell, has been borne home with full force.

Distribution is the deciding factor today.

Big concerns are organizing on a selling basis first, believing that production is a later if not a lesser problem.

* * *

AND along with this higher development of sales methods and forces, another phenomenon is under

way, just the same thing that happens inevitably in the evolution of every other young industry, namely, *every day the desk of the advertising manager is being shoved nearer and nearer to the desk of the sales manager.*

* * *

IN other words, it is more and more clearly recognized that the advertising and marketing of films go hand in hand and *should* be inseparable—that either is inefficient without the other.

* * *

ADVERTISING is selling—either directly or indirectly—the more directly the better. It has got to be direct, unless it is only a preliminary part of a big nationwide campaign that is backed with a huge appropriation.

Advertising has progressed in this field. It is one of the plainest signs of the big advance made in the industry within a year.

Good advertising men have come into the field and they are working along *selling* lines. It is the accepted order of the day.

One has only to study the advertising pages of the last issue of the MOTION PICTURE NEWS and then compare them with the copy of a year ago to note the great improvement.

* * *

PERHAPS the chief advance made is in "reason-why" or argumentative text and then—most importantly—the fact that it indicates clearly where and how the goods can be obtained.

In other words, these are selling advertisements, every one of them, yoked up closely with a method of distribution.

* * *

ADVERTISING was never meant to tickle the vanity of the advertiser, nor to make his competitor jealous.

Again, it will never be successful if it is baffled by defective distribution.

* * *

THAT is to say, the reader will certainly *not* respond if he can't get, *easily*, the goods advertised.

The moral of which, for the advertiser, is: Is it easy for the reader to get what you are asking him to?

WILLIAM A. JOHNSTON.

PRESIDENT PEARCE ATTENDS KANSAS CONVENTION

President Marion S. Pearce has just returned from a trip through the West in the interests of the League. He finds conditions as a whole very encouraging, especially in Kansas, where they have just closed a most successful state convention.

On this occasion many matters of vital interest to every exhibitor in the state were transacted, and much good for the general welfare of the League in that locality accomplished.

President W. B. Moore, of the Kansas state branch, was especially enthusiastic regarding the League work in his territory, and took great pleasure in announcing that they had decided on a definite membership campaign.

He looks forward confidently to the next convention, which will be held in Emporia, Kansas, some time during March, when he feels sure that almost every exhibitor in the state will by that time be a member of the League.

President Pearce also stopped off in Illinois in the interests of re-organizing the state. He devoted there as much time as he felt he could spare, although realizing the importance of being in touch with Washington, where he has been keeping in close touch with the progress of the war tax measure.

DAYTON LEAGUE WILL FIGHT UNJUST ORDINANCE

Special to MOTION PICTURE NEWS

Dayton, O., Oct. 13.

Licensing of motion picture houses by the city will be fought by the League branch here, officials announce. The city administration has indicated to officers of the branch its intention to pass a special ordinance, classing motion picture houses as "theatres" and as such assessing them under a license system.

The cost of the licenses will range from fifteen to a hundred dollars according to the seating capacity. The exhibitors declare the proposal is unfair, especially since the courts, in a local injunction suit, have ruled that the motion picture shows cannot come under the state statutes for license as theatres.

ATSCO, INC., CELEBRATES SEVENTH ANNIVERSARY

Atsco, Inc., has just celebrated its seventh anniversary. Atsco is rejoicing in a most appropriate manner—reading all the letters received in the past seven years from hundreds of pleased patrons from all parts of the globe: Calcutta, Honolulu, Japan, China, Australia, England, France, Germany; in fact every known country that boasts of a motion picture theatre, including of course those that boast of a Radium Gold Fibre screen.

Not alone has Atsco, Inc., received letters of praise of the screen, but of its many other supplies that are helpful to a manager who wishes to make his theatre a success.

Oklahoma League Agitates Higher Prices

Will Start Educational Campaign to Bring Public to a Realization of the Impossibility of Maintaining Five Cent Admissions

Special to MOTION PICTURE NEWS

Muskogee, Okla., Oct. 12.

THE Oklahoma State Branch, No. 23, Motion Picture Exhibitors' League of America, met in special session at the Lee-Huckins Hotel, Oklahoma City, September 29-30. As the meeting was held during the State Fair, the hotels were crowded to the utmost with visitors.

Many exhibitors came in to attend the meeting, and were unable to obtain rooms at the hotels. About thirty-five members were present, including all of the officers: Albert Jackson, Pawhuska, Okla., president; B. H. Powell, Oklahoma City, vice-president; O. McLane, Oklahoma City, second vice-president; L. W. Brophy, Muskogee, Okla., secretary, and Ralph Talbot, Tulsa, Okla., treasurer.

It was strongly urged that locals be formed in all of the larger towns of the state at once. A publicity campaign was started to educate the public to under-

stand that it is impossible to furnish the high-class film that the public has come to expect for an admission price of five cents in Oklahoma.

A committee of five was appointed to confer with the representatives of the Mutual, Universal and the General Film companies. The film companies' representatives showed themselves to be unanimously in favor of this movement, and agreed to co-operate as far as possible with the members of the league.

The exhibitors of one town, Shawnee, Okla., where there are four five-cent shows, practically agreed before leaving the hall that they would raise the price to ten cents at once. Other features of the convention were the attendance at the State Fair in a body, on Tuesday afternoon, a serving of refreshments, and a smoker Tuesday night at 11 p. m., which was followed up with a cabaret entertainment by sixteen people. The next meeting will take place in February, 1915.

Spokane Operators' Law Thought Too Strict

Exhibitors and Booth Employees Ask Authorities for New Ordinance—Certificate Can Be Revoked for Any of Twenty-two Reasons

Special to MOTION PICTURE NEWS

Spokane, Wash., Oct. 12.

PROPRIETORS of some local motion picture theatres and a representation of the operators have asked the city council to pass a new ordinance providing for the regulation of operators and for the use of motor-driven machines.

After providing stringent rules governing the building equipment and general arrangement of the operating booths, the ordinance provides that no operator may be employed in any of the houses without a proper certificate from the commissioner of public safety. The operator must register with the commissioner, giving his name, age,

residence, experience and where he proposes to work, with an affidavit that the statements are true.

This shall entitle the operator to a certificate for one year. All operators are required to be over twenty-one years of age and each must have had three months' experience.

The following are a few of the twenty-two reasons for the revocation of an operator's certificate:

Failure to display his certificate, smoking in the operating room, intoxication on duty or having liquor in the booth, allowing a booth door to stand open, negligence, carelessness or a dirty booth, failure to report all film fires to the department of public safety.

Kentucky Exchange Urges Organization

Will Hold Up Prices and Keep Bad Accounts at a Minimum, Declares Sheldon of Louisville, in Calling for Concerted Action

Special to MOTION PICTURE NEWS

Louisville, Ky., Oct. 14.

F. M. SHELDON, manager of the S. & P. Film & Supply Co., is urging the organization of an association of exchange men.

"Such an organization," says Mr. Sheldon, "would have a tendency to hold up prices, in addition to which the exchange men would be greatly benefited by a consequent ability to hold bad accounts to the minimum in number." Mr. Sheldon suggests that the film companies have a book in which all exhibitors are closely and accurately rated.

It is stated that a large number of exhibitors are exceedingly slow in settling

accounts. If the exchange men could be organized, they would be in position to command a cash in advance of C. O. D. system of payment for service.

"Film exchanges are forced to pay cash for their films," says Mr. Sheldon, "and there is no reason why the exhibitors should not do business the same."

Mr. Sheldon is one of the most consistent boosters for the business in this territory, and is a great believer in the use of liberal advertising space. "The trade journal," he says, "has an advantage over the circular, which is largely used, from the fact that the periodical will reach a great many more exhibitors, at less expense." F. D. VANOVER.

"Motion Picture News" Campaign Against War Tax Creates a Sensation at Washington

Even Patrons of the Photoplay Theatres Aroused to Sympathy by Powerful Presentation of Exhibitor's Position—League Heads Urge "News" to Keep Up the Good Work—"News" Is Doing Much to Bring About Organization Within the Industry," Declares Exchange Manager—Brylawski Endorses the Campaign

Special to MOTION PICTURE NEWS

Washington, D. C., Oct. 14. THE fact that MOTION PICTURE NEWS saw fit to devote eight pages of its issue dated October 17 to the proposed war tax on the motion picture theatres has caused little less than a sensation in the Capital City. It brought the fact so forcibly before the public that even the patrons of the film drama realized the injustice of the tax.

The startling question on the title page, "Have you \$100 to throw away?" caught the eye at once and aroused curiosity, as money always does. Of course, the last word before going to press showed that a modification had been made in the bill by the amendment of a proportional tax, according to the seating capacity of the theatre, but this seemed to arouse additional interest. The prominence of the part Washington is taking in the fight, and especially the work of Fulton Brylawski, proved an additional source of stimulation.

Fulton Brylawski, one of the authors of the amendment to the proposed tax as affecting the motion picture theatre, was especially appreciative of the space and prominence given to the matter. "It is splendid!" he said, "And my message to the NEWS is to keep up the good work. The bill is again before Congress for consideration and I shall be at the capitol myself to watch its progress closely."

Wm. P. Herbst, president of the local Exhibitors League, had this to say: "This edition of the NEWS is fine, and shows what can be done. The motion picture men are chiefly making the fight, but the entire theatrical profession will profit by the results."

Sidney B. Lust, manager of Warner's Features, had this to say: "The NEWS deserves much credit for this week's issue."

Nat. Gassier, manager of *The Leader*, remarked: "The publicity given the war tax situation in the NEWS is what the matter needs. It has given the right man the credit, too, and that man is Fulton Brylawski. The motion picture men have done more in this fight than all the theatrical corporations put together, and the NEWS is letting the people know what is being done."

G. H. Christoffer, special representative of the World Film Corporation, commented: "The big thing the NEWS is accomplishing in giving so much space to the war tax is showing the advantage of organization and what or-

ganization can do. That's what the whole motion picture industry needs, and the NEWS is doing much to bring about that end."

The war tax measure is now before Congress in its amended form.

The bill is not as yet a law and it may be changed before appearing in its final form. While the motion picture exhibitor is but one phase of the theatre business, it is the Motion Picture Exhibitors League that is chiefly responsible for the present amendment. All the vast theatrical enterprises will also profit by this proportional scale of tax, or any other modification of the bill. By united efforts even greater things can be accomplished. This is what the motion picture business needs—*organization*.

The present tax situation is but one of the many instances that will call for strong organization. Now that the motion picture business has become involved in the federal congress, it is likely to become more conspicuous.

Speaking to Fulton Brylawski on the subject, he had this to say:

"The amended bill is before Congress and should be acted upon shortly. We cannot afford to be too sanguine of the outcome. My message to MOTION PICTURE NEWS and every exhibitor is to keep up the good work so splendidly begun."

THEODORE FRANKLIN.

Managers Association Prepares New Tax Rate

The amendment to the war tax suggested by Fulton Brylawski, secretary of Washington, D. C., Exhibitors' League, has not met with the views of the United Managers' Protective Association of New York, inasmuch as the figures, according to Ligon Johnson, secretary of the organization, are too high for the average motion picture theatre.

Mr. Johnson has prepared a scale graded with the purpose of relieving the smallest houses of a burden they are unable to bear, and placing the bulk of the tax on these which can better afford to pay the tax. Copies of the schedule have been sent to all members of Congress and various labor organizations affiliated with the theatrical business. The schedule follows:

It is respectfully suggested that the tax should first be graded by population, that is to say a maximum of \$100 be placed on Class A theatres in cities of

500,000 population and over, and graded into five divisions, these to be: (1) Theatres in cities of 500,000 population and over; (2) cities under 500,000 and over 250,000; (3) cities under 250,000 and over 100,000; (4) cities under 100,000 and over 15,000; (5) cities under 15,000.

We would further suggest that the theatres be divided into three classes: Class A playing theatrical attractions proper; Class B mixed (so-called small time vaudeville and pictures), and Class C, motion pictures exclusively. This grades the entrance charges to theatres.

To be fair each of these classes should be divided into sections as to seating capacity, that is (1) 300 and under; (2) over 300 and up to 600; (3) over 600 and up to 1,000; (4) over 1,000. This is particularly true of motion picture houses. We believe the following would contribute considerably more than the theatres' just share of any war tax.

In theatres of the first class, in cities of the first division (over 500,000), we suggest a tax of \$100; in cities of the second division (over 250,000 but under 500,000), \$50; in cities of the third division (over 100,000 but under 150,000), \$25; in cities of the fourth division (under 100,000 and over 15,000), \$15; in cities of the fifth division (under 15,000), \$10.

For theatres of the second class (vaudeville and pictures), in cities of the first division, \$50; in cities of the second division, \$35; in cities of the third division, \$20; in cities of the fourth division, \$10; in cities of the fifth division, \$7.50.

For motion picture houses in cities of the first division: Theatres seating 1,000 or over, \$25; under 1,000 but over 600, \$20; under 600, \$15. In cities of the second division, seating over 1,000, \$20; between 600 and 1,000, \$15; under 600, \$12.50. In cities of the third division, seating over 1,000, \$15; between 600 and 1,000, \$12.50; under 600, \$10. In cities of the fourth division, seating over 1,000, \$10; between 600 and 1,000, \$7.50; under 600, \$5.

JOHNSTON TO MANAGE NEW NIAGARA HOUSE

Special to MOTION PICTURE NEWS

Buffalo, Oct. 14.

Charles N. Johnston, now at the International Theatre, Niagara Falls, N. Y., will assume the management of the new Ellen Terry Theatre at the corner of Potomac and Grant street, upon its opening in a few weeks.

FAMOUS PLAYERS SIGNS CRANE FOR "DAVID HARUM"

In inducing William H. Crane to appear before the camera, the Famous Players Company has achieved a notable result. For many years Mr. Crane re-



WILLIAM H. CRANE

sisted fabulous offers from a number of important film concerns to prevent one of his great characterizations in motion pictures, and he is one of the last of the more important stars of the contemporary stage to record his art on the screen.

The Famous Players have been equally felicitous in securing the film rights of "David Harum." More than any other of Mr. Crane's great dramatic successes, not even excluding his sensational triumphs, "Father and the Boys," and "The Senator Keeps House," this play has won the sympathies and admiration of the American public and will probably be recorded as this master artist's greatest characterization.

The production will be a forthcoming release on the Famous Players program under Paramount distribution.

MALCOLM MADE PORTLAND MANAGER FOR GENERAL

Special to MOTION PICTURE NEWS

Los Angeles, Oct. 13.

T. C. Malcolm, who for several years was connected with the Los Angeles General Film Company exchange in the capacity of assistant manager, and who has held a similar position in the San Francisco office of the same company for the past few months, has been appointed manager of the Portland office of the company, and has taken up the work in his new field.

Mr. Malcolm was very popular with the Los Angeles exhibitors and they are very glad to hear of this promotion.

Film Drama Leads Vaudeville in New Haven

Poli's Now Runs a Feature as the Headliner of Each Bill—Prices Reduced—Advertises Largely in Dailies

Special to MOTION PICTURE NEWS

New Haven, Conn., Oct. 14.

THE "silent drama" has again delivered a telling blow to the "legit" in this city, in forcing New Haven's two remaining vaudeville houses—both part of the vast Poli chain of theatres—to take up motion pictures, one almost exclusively, and the other in large measure.

The two houses that have adopted new policies are Poli's Theatre and Poli's Bijou Theatre. The first was formerly conducted as a first-class vaudeville house, running two performances a day with pictures almost a negligible factor of each bill. Prices ranged from ten to twenty cents, matinees, and to fifty cents, evenings.

In this house, prices have been reduced so that the highest is twenty-five cents; there are three performances each day—one matinee and two night; there are no reserved seats, but in their stead a "first-come, first-served" policy; and a feature motion picture is made the headliner of each bill.

As evidence of the high character of the film part of the performance, it may

be mentioned that "Cabiria" was recently the weekly attraction. The public evidently appreciates good films.

The same policy that now holds sway at Poli's Theatre was formerly that of the Bijou. Paramount pictures are featured at the Bijou now. The Bijou has exclusive rights to the Paramount first runs, and by the terms of its contract may, and does, show all of the latest releases three months before they can be obtained by any other exhibitor in New Haven. Inasmuch as the Paramount program is considered without peer here, this fact is significant. The pictures form the principal part of the Bijou entertainment.

The manner in which the Poli attractions at both theatres are advertised is in a large measure responsible for the success they are meeting with. Considerable space is taken daily in all of the newspapers, and the amount is increased twice a week at the opening of each new bill. Mondays and Thursdays the pictures are viewed by critics, and written up in the following day's papers.

AMSTER SPINO.

Plan to Group All Newark Exchanges

Strand Theatre Manager Urges Distributors in New Jersey City to Take Offices in One Building—Two Accept the Offer

Special to MOTION PICTURE NEWS

Newark, N. J., Oct. 14.

ALL the exchanges in Newark may be under one roof within a few weeks, if plans formulated by Emil Gerstle, manager of the Strand Theatre, Market, near Halsey street, mature. There are many offices in the Strand Theatre building, and some of them are vacant at the present time. There are about a half dozen exchanges in Newark, and they are pretty well scattered through the business section of the city.

Mr. Gerstle is trying to get the exchanges to move into the empty offices in his building. Two have already done so. They are the Metropolitan Motion Picture Company and the State Feature Company. Some of the other exchanges have practically agreed to go into the Strand building.

For the convenience of the exchanges, Mr. Gerstle has had erected in the rear of the theatre, a little building specially designed by himself for the storage of films. The little structure, which is about 12 feet wide and 20 feet long, is constructed entirely of metal and it is absolutely fireproof. It is built practically the same as a portable garage. There are five metal doors in the front of the building, each provided with a strong lock, and these doors lead into five compartments in which films may be stored.

The idea has been heartily endorsed by Albert Gasser, chief of the Bureau

of Combustibles. Each of the exchanges in the Strand building is given the use of one of the compartments where they may keep their films. The plan is excellent and a similar one might be inaugurated elsewhere to advantage.

J. W. HAWKINS.

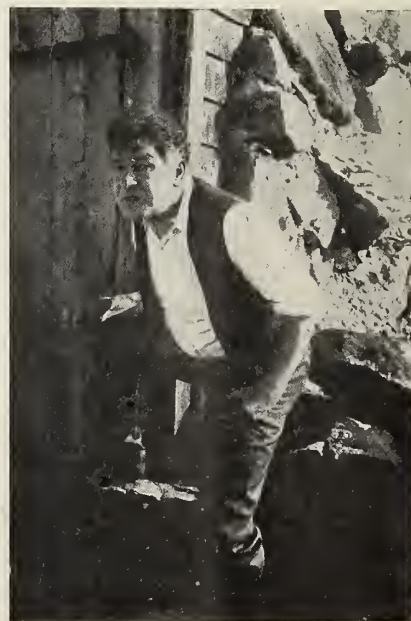

WILLIAM RILEY HATCH IN "SHORE ACRES"
(All-Star—Alco Feature)

CALIFORNIA CONVENTION HUMS WITH BUSINESS

Exhibitors from All Over the State Attend Gathering at San Francisco—Lack of Finances Emphasized by President—Members Demand Regulation of Shipping Rates and Exchange Service—League Will Undertake Membership Campaign and Bind Country Exhibitors Closer to Main Body

Special to MOTION PICTURE NEWS

San Francisco, October 12.

THE third annual convention of the Motion Picture Exhibitors' League of California was held in San Francisco on October 6, 7, 8 and 9, and while the attendance was lighter than was expected, in view of the many important questions scheduled for discussion, it was quite representative, exhibitors attending from as far south as San Diego, as well as from the extreme northern section of the state. The convention was originally planned to be held at Sacramento, but at a late date it was decided to change it to San Francisco, in the belief that a larger attendance could be secured.

The meeting was held in the assembly hall of the Phelan Building where the offices of the league are located. The active business session did not commence until afternoon. Most of the time in the morning was taken up with the registration of exhibitors and the planning of committees. At the afternoon session the visitors were formally welcomed to the city by a personal representative of the Mayor and State President Charles Goddard made a short address, which was followed by the naming of the following committees:

Resolutions: J. G. Piratsky, C. C. Kauffman and W. S. Smith; credentials: L. Marks, William Englehart and C. E. Hart; auditing: H. C. Schmidt, A. M. Bowles and W. Krohn.

Advise Membership Campaign

President Goddard then read his annual address, in which he outlined some of the important work that he hoped would be taken up by the convention. He expressed regret that the membership of the organization was not larger and recommended that the matter of securing new members be earnestly taken up. He advised that a special committee be appointed for organization work and that efforts be made to interest country exhibitors in the work of the league.

He traced the tendency, especially in the large cities, toward the consolidation of small moving picture houses into large concerns, operating theatres rivaling those of the legitimate stage, and declared that in these changes something must be done to protect the small exhibitors who are left. He stated that the small house was still the backbone of the business and that there were many questions that must be decided that affected these almost exclusively.

The president called attention to the fact that the California State Legislature would meet in regular session early in January and urged that a very careful watch be kept on all legislation affecting the moving picture industry.

Urges Agreement on Posters

In dwelling upon the poster question, he expressed the opinion that inasmuch as the posters now being put out advertise the film manufacturers and not the exhibitors, it would be no more than fair if these be furnished free with films. He further suggested that some action be taken toward reaching an agreement with film exchanges to this end.

In glowing language he outlined the wonders of San Francisco, the Exposition City, and trusted that the National convention could be brought here in 1915. He believed that this would be one of the greatest aids to building up a strong State organization and recommended that a committee be named to assist in bringing the convention to California.

In this connection it might be added that the delegates present were enthusiastically in favor of this proposition.

In discussing the finances of the league, President Goddard stated that he found this a humiliating subject. The failure on the part of members to pay their dues promptly had many times left the treasury practically empty and at times the lack of funds had been embarrassing. He called attention to the fact that the league had been compelled to break its contract with Attorney Leo Kaufmann for this reason and paid a glowing tribute to that gentleman for the very effective work that

he had done for the organization, largely without recompense. He stated that there was owing Mr. Kaufmann the sum of \$145 and further added that if action was not taken at this meeting to settle the account, he would draw his personal check in this sum.

Beach Proposes Monthly Bulletins

The president closed his address with a statement of appreciation of the action of the Los Angeles exhibitors in again affiliating with the organization and with another appeal for an increased membership.

Secretary W. A. Cory and Vice-President H. S. Beach then took the floor in succession. The latter submitted a proposition calculated to keep exhibitors, especially those in the country districts, in closer touch with the work of the league. He declared that much of the apathy on the part of out of town exhibitors toward the organization was due to the fact that they had no means of learning what was being done, unless, by chance, they happened to come to San Francisco. He proposed that a small bulletin be issued each month, or at such times as would be thought advisable, this to contain a condensed report of what the league was doing, and what it planned to do. This bulletin would be sent to all members of the league, and to others who were eligible to membership. He expressed the opinion that it could be made self supporting, as many of the exchanges would doubtless be glad of the opportunity to reach customers in this direct manner.

The president named J. Ray Williams, H. S. Beach and W. B. Martin to attend to the proposition. On motion the president also appointed a committee on organization and another on finance, the first consisting of Leo Kaufmann, H. C. Schmidt and L. E. Lund, and the latter of L. Marks, M. E. Cory and W. H. Hilts.

Want the Shipping Rates Uniform

W. A. Cory then read several communications from country exhibitors asking that action be taken on the matter of more uniform express charges, and of shipping film by parcel post. In the discussion that followed a number of questions were brought up that pertained exclusively to those operating houses in the country districts and it was decided that these questions could be best cared for by a committee of country exhibitors.

Accordingly, President Goddard appointed a committee of five from widely separated sections of the State to frame resolutions pertaining to shipping, and kindred subjects, this consisting of W. H. Rapp, chairman, Nick Turner, O. Byers, A. M. Bowles and S. Greenwood.

Mr. Cory then read another communication from a country exhibitor suggesting that action be taken toward inducing light and power concerns to make a change in their system of charging for service. It was suggested that moving picture houses should be granted a rate, as for manufacturing, instead of being called upon to pay the same rates as owners of dwellings.

A communication was then read from the Merchants' and Manufacturers' Association asking that moving picture owners throughout the State run slides in their houses protesting against the passage of the proposed eight-hour law, and asking further that the league go on record in opposition to this measure. This proposition aroused a lively controversy, several members making it plain that they were in favor of the eight-hour law, and giving their reasons for this stand. It was moved and seconded that the communication be filed.

Secretary Cory read a letter from Chas. Rothschild, dated last June, tendering his resignation as an officer in the league, on account of his retirement from the moving picture field. It was moved and seconded, and unanimously adopted, that

(Continued on page 58.)

DALLAS FIRM BANKRUPT

Special to MOTION PICTURE NEWS

Dallas, Oct. 12.

The Southern Feature Film Association, of Dallas, has run aground of the shoals, and is now in trouble. Some of the troubles of the company have been aired in a petition filed in the district court at Dallas, in which a receiver for the company was asked.

The application for the receiver was filed by George W. Slator, as principal stockholder. Clyde W. Slator was named as receiver by the court, and his bond was fixed at \$10,000.

According to the petition the assets of the company are estimated at about \$80,000, and the liabilities are fixed at \$40,000. The assets consist chiefly of rights in motion picture feature films. The petitioner recites that the company is still a going concern, and if given time can pay off all its indebtedness.

This was one of the largest motion picture concerns in Dallas, and controlled a number of feature films which are circulated in this section of the country.

INTERPRET LAW TO HIRE EXTRA STAGE HAND

Special to MOTION PICTURE NEWS

Syracuse, Oct. 14.

A question, the settlement of which may establish a precedent in theatrical and motion picture labor matters, has been referred to a special committee by the Central Trades Assembly.

This concerns whether or not stage hands shall be employed in motion picture theatres which have a stage and is aimed principally at the Crescent and Regent Theatres, two of the largest in Syracuse. Under the law, a theatre with a stage must have an asbestos curtain which must be raised and lowered before and after the performance.

The union is endeavoring to interpret the law to the fine point of forcing an extra hand upon the theatres and trouble is brewing.

SEPARATE SEATS FOR WOMEN

Special to MOTION PICTURE NEWS

San Francisco, Oct. 12.

The Juvenile Protective Association, a San Francisco organization that has done much to protect the youth of the city, recently sent a committee to a meeting of the Exhibitors' League of San Francisco to arrange, if possible, for theater owners to set aside a reserved section in their houses for the exclusive use of children and ladies without escorts.

The view was expressed that with crowds of strangers in the city during 1915 such a policy would be a protective measure of value. The League will take the matter up at some future meeting, and in the meantime the proposition is being discussed by members of the organization.

Warner Managers Meet in Convention

Exchange Representatives Assemble in Buffalo to Discuss Successful Launching of New Feature and Comedy Program

THE successful launching of the new feature and comedy program by Warner's Features, Inc., was the chief topic discussed at a convention of Warner's exchange managers in Buffalo on October 10.

P. A. Powers, president, and O. S. Goan, treasurer and sales manager of the company, conducted the meeting. There was a tremendous amount of enthusiasm shown, and all the managers present declared that the new service had stirred up exhibitors throughout their respective territories.

Harry Charnas, of Cleveland, made a brief report which was typical of that received from each manager.

"As a result of the preliminary announcements," said Mr. Charnas, "the Cleveland exchange has been overwhelmed with inquiries and applications for advance bookings. The interest in our new program displayed by exhibitors is really phenomenal.

"It has also been rather embarrassing, for the reason that many of these exhibitors have been in a hurry to get started with our program, and wanted us to rush it. I am not overstating the situation when I say that even before its appearance our new program proved an instantaneous success."

At the afternoon session President Powers delivered a short address in which he outlined the development of the Warner's program to its completion. In concluding he said:

"I realize perfectly well that you gentlemen on the firing line have up to

now been in a peculiar position. You have been constantly asked by exhibitors why you didn't get the new service started. But remember that you can't prepare and release in a few weeks a program of the quality which we have prepared. If we had rushed matters without regard to quality, the program would have been ready much sooner; but it would then have been an ordinary program—here today, and gone tomorrow. As it is, the first installment of our feature and comedy service now going out to exhibitors represents the highest type of motion picture.

"One of the great events in connection with our new service was the banding together of a dozen or more of the most experienced and successful motion picture makers in the world for the single purpose of providing the Warner's program. This organization is the United Motion Picture Producers, Inc.

"It is a concrete, firmly established organization formed on a sound and permanent basis. Never before in the history of the industry has such an organization for such a purpose been formed. It shows that our own company enjoys the unqualified confidence of the great producers, just as your advance bookings show the confidence exhibitors feel in Warner's Features, Inc.

"We, in conjunction with the United Company, have worked along definite lines in getting the program started—and now that it has started, every exhibitor who has booked it will find that it has been worth waiting for."

Edison Plans Four Strong Series

All by Well-Known Authors—"Below the Dead Line," First Release, Deals with Exploits of Noted Fiction Creation

THE Edison Company will launch four new series of photoplays from stories written by well-known authors. There will be no chain of connected episodes. Each story will be of independent and complete interest.

"Below the Dead Line" is a series of strong detective stories by Scott Campbell, and deals with the exploits of a celebrated private detective, Felix Boyd, employed by large financial concerns in New York City. Robert Connors will appear as this character throughout the series. The first, "The Case of the Vanished Bonds," was released October 17.

"Young Lord Stranleigh," by Robert Barr, a series which appeared in the "Saturday Evening Post," embraces four two-reel subjects in which the young aristocrat will afford an excellent vehicle for Marc MacDermott. The girl with whom the lord is in love will be played by Miriam Nesbitt. The initial installment, "The Kings Move in the City," will be released November 27.

"Olive's Opportunities" is the title of a series especially written for the Edison Company by Mrs. Wilson Woodrow, the well-known author whose stories are full of virility and action. Mabel Trunnelle will be known as "Olive," the young girl brought up in a gypsy camp, whose parentage is a mystery. Irrepressible and full of the joy of living, she will go through many exciting situations. "A Gypsy Madcap" is the first story to be released, on December 1.

"The Girl Who Earns Her Own Living" is a series by Mark Swan, who has written exclusively for the Edison Company for about two years. In this series each story will show the struggle of a young girl to maintain a decent existence, and the girl in each story will be a different character. Each one, however, will be played by Gertrude McCoy.

The first release of these dramatic and human interest stories will be "The Stenographer," on December 5.

"PAY FOR POSTERS!" SAY COAST EXCHANGES

San Francisco Body Meets for Organization Purposes, Appoints Constitution and By-Laws Committee, and Draws Up Tentative Scale of Prices on Paper from One-Sheets to Twenty-four Sheets—Exhibitors Protest Against Advertising Locale of Film Productions

Special to MOTION PICTURE NEWS

San Francisco, October 12.

THE movement recently inaugurated at San Francisco for the formation of a protective organization among film men has met with general approval, and at a meeting held a few days ago in the Pantages Theatre building the preliminary steps were taken to organize what will probably be known as the San Francisco Film Exchange Men's Board of Trade.

The purposes of the organization, as outlined at this gathering, are to protect local film men from the operations of dead-beats and to keep track of exhibitors who insist on operating machines which ruin films, and employ operators who show a disregard for the proper handling of the property of exchanges.

The meeting recently held was remarkable for the attendance, practically every exchange in business in San Francisco being represented by one or more, and the extent of the industry here may be judged from the fact that there are more than twenty firms soliciting business.

At Work on a Constitution

It was decided to place the drafting of a constitution and by-laws in the hands of a committee of five, and the following were selected to attend to this work: Tom North, manager of the San Francisco branch of George Kleine Attractions; Morris L. Markowitz, head of the California Film Exchange; Sol Lesser, president of the Golden Gate Film Exchange and the All Star Feature Distributors; J. Crone, manager of the San Francisco and Los Angeles branches of the Pacific Mutual Film Corporation, and O. V. Traggardh, head of the Union Film & Supply Company and the Supreme Features Corporation.

The services of a corporation lawyer have been secured, and as soon as the constitution and by-laws have been completed they will be presented to the organization for its approval and a permanent body will then be formed.

In addition to protecting its members against bad debts and unskilled operators the organization will probably attempt to correct some of the evils that now attend the distribution of posters.

It is planned to have everyone pay for posters and the following list of prices for mounted stock was tentatively agreed upon as being reasonable: 1 sheet, 5 cents; 3-sheet, 25 cents; 6-sheet, 40 cents; 8-sheet, 50 cents; 9-sheet, 60 cents; 12-sheet, 75 cents; 16-sheet, \$1, and 24-sheet, \$1.50.

It is not the intention of the organization to make any attempt to raise prices of either films or paper, but merely to protect its members against those

who prey upon exchanges, as well as upon exhibitors. The latter have suffered heavily of late through the tricks of imposters and will welcome the efforts of film men to minimize the operations of these.

Seek Law Against War Films

The success that has been met with by several exhibitors and exchange men in San Francisco in securing injunctions against the Police Department to prevent interference with the exhibition of moving pictures showing war scenes has caused the Chief of Police to change his tactics, and he is now attempting to secure the passage of an ordinance by the Board of Supervisors making it unlawful to display so-called war pictures in local moving picture theatres until after the close of the present war in Europe.

The Police Committee of the Board of Supervisors, consisting of Oscar Hocks, Fred L. Hilmer and Edward L. Nolan, has agreed to the passage of this measure, as has also the Judiciary Committee, consisting of Charles A. Nelson, Ralph McLeran and Alexander T. Vogelsang. Motion picture interests heard of the proposed legislation at a late hour and legal representatives, including Attorney A. S. Newburgh, were present.

Mr. Newburgh voiced opposition to such an ordinance, but the legislation was unanimously approved by the committees. Theatre owners will attend the next meeting of the Board of Supervisors in numbers, as it is understood that other matters affecting their interests will be incorporated in the ordinance that is being drafted.

Against "Labeling Localities" in Film

The proposition that is being agitated in several large producing centres of having the name of the locality in which the picture is made appear upon the screen does not meet with general approval on the part of San Francisco exhibitors, in spite of the fact that this place is in the heart of an important producing district. In speaking of this matter one prominent theatre owner said:

"On the face of it this seems like a good thing, but I have arrived at the conclusion that the labeling of films in this manner will do more harm than good. Contrary to the general impression, I have found that my patrons are not at all anxious to find out where a film has been made.

"If it is a Canadian scene, they go away from the theatre with a better feeling than if they found that it was a picture made in the hills back of San Francisco. Or if it is a picture illus-

trating an action that took place in the Civil War a much more profound impression is created if the audience is led to believe that it has been made in the region where the action actually took place. I think that scenic subjects are the only ones that should be labeled with the locality in which they are made, unless it be photo plays enacted on the original ground."

M. E. Cory, president of the Motion Picture Exhibitors' League of San Francisco, and vice-president of the National organization, is another who believes that the labeling of the locality is a mistaken idea. He is of the opinion that the illusion that is created is one of the chief charms of moving pictures, and that to destroy this would be to cause the public to lose interest in them. He expresses the opinion that if the plan were to be followed out generally a loss might result to exhibitors.

With Exhibitors and Exchangemen

B. E. Rosewald, who formerly conducted the Sherman Theatre in the Mission district, San Francisco, Cal., has taken over the management of the Imperial Theatre at Eureka. This latter city is located in the great redwood belt of California, and is the largest city in the United States not connected by rail with the outside world. By the end of October, however, a railroad from San Francisco will be in running shape, and business is expected to be greatly stimulated as a result.

The Box Office Attractions Company opened for business at 107 Golden Gate avenue, San Francisco, Cal., on October 1, under the management of Wm. Citron, formerly with the General Film Company.

The Photoplay Theatre at Burlingame, Cal., is to be enlarged at an early date, and a number of improvements will be made to the present equipment.

The Movea Film Service is one of the latest concerns to enter the producing field at San Francisco. This concern was incorporated here with a capital of \$150,000 by John C. Terry and H. M. Shields, newspaper men; C. D. Longhurst, Timothy Healy and T. E. J. Gardner, the latter a photo-engraver.

An invention of importance in the manufacture of comic cartoon films is controlled by this concern, and it is claimed that pictures of this kind can be turned out in one-tenth the time now required. In addition to a domestic business this firm plans to enter the export field, principally with South and Central America.

The Empire Theatre, Fresno, Cal., which was to have been opened for the fall and winter season about the first of October, was damaged by fire last week.

The new White Theatre at Fresno, Cal., is nearing completion, and will be opened early in November, according to the present plans.

G. F. Gillelen has purchased the Webster Theatre at Alameda, Cal., and will expend several thousand dollars in remodeling work and in new equipment.

J. Roy Sibley has purchased the Fairyland Theatre on Devisadero street, San Francisco, Cal., built and conducted by Cory Bros. M. L. LANGHORST.

NEW LABORATORY IN LOS ANGELES

Special to MOTION PICTURE NEWS

Los Angeles, Oct. 12.

A new motion picture laboratory, modern in every respect, and having a capacity of almost two million feet of positive film per week, will be opened in the very near future at 3123 South Hoover street, Los Angeles, by a new California corporation, the International Laboratories, the owners of which are W. H. Faust, of the Faust Motion Picture Company; N. L. Borrow, and Stuart Featherstonhaugh.

Mr. Featherstonhaugh will be superintendent. He was formerly connected with the Vitagraph, Imp, Melies and other laboratories, in all having seven years' experience.

CHANGE IN UNIVERSAL PROGRAM

On October 19, the Wednesday Nestor release on the regular program was transferred to Tuesday, and took the place of the Universal Ike comedy, which brand was discontinued. The Sunday Frontier will be transferred to Saturday, and the L-KO will start Sunday in the place of the Frontier.

The First L-KO comedy, entitled "Love and Surgery," in two reels will be released Sunday, October 25. The L-KO brand will be released every Sunday thereafter.

EXHIBITOR TRIES HIGHER PRICES IN KENTUCKY

Special to MOTION PICTURE NEWS

Louisville, Ky., Oct. 14.

Arthur Mitchell, of the Dixie Theatre, of Russellville, Ky., has contracted for a big feature every week. The first to be shown this week is "The Last Days of Pompeii," in ten reels. The admission on feature days will be ten and twenty cents.

This policy will be continued if the photo-play enthusiasts of Russellville show their appreciation of the efforts to provide high-class films.

BUILDS SECOND THEATRE IN HIS TOWN

Special to MOTION PICTURE NEWS

Pana, Ill., Oct. 14.

Charles J. Law, a prominent Illinois exhibitor, who owns a theatre in Nokomis, and one in Pana, has just built another in Pana. The new house in Pana is the third of Mr. Law's.

Regent, \$100,000 Syracuse House, City's Pride

Decorations Throughout Make Theatre a Temple of Beauty—Will Show Pictures Appealing to Critical Public in Western New York City

Special to MOTION PICTURE NEWS

Syracuse, N. Y., Oct. 14.

SYRACUSE theatregoers have reason for self-congratulation on the magnificent \$100,000 photoplay house, the Regent, which has been added to the city's places of amusement.

The Regent is claimed to be one of the most beautiful houses in America. On Genesee street through a lobby beautifully decorated in chinoise blue and old ivory, one enters the foyer and the eye beholds a vision of splendor. There is a hint in the lobby of this restful color scheme, which makes the playhouse itself

first floor. The seating capacity of the Regent is about 1,500, of which 1,200 seats are on the main floor, the balance consisting exclusively of box seats on the mezzanine floor.

The Regent is of steel, concrete and brick construction and is declared to be absolutely fireproof. The exits are numerous and the aisles wide. A spacious and beautifully furnished reception room is placed on the left of the foyer for the comfort of women and a large smoking room for the men is placed on the right.

Merton H. Schwartz promoted and or-

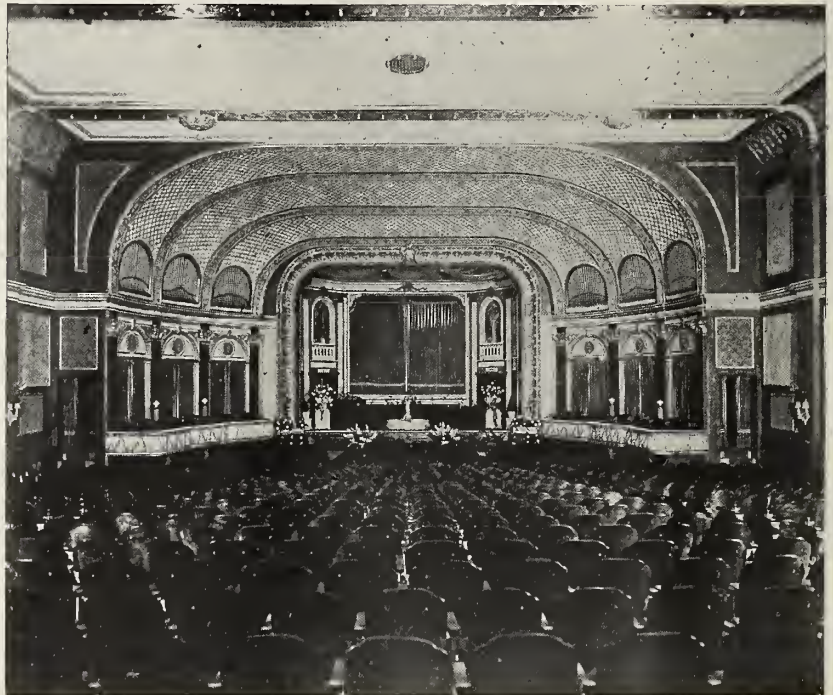

STAGE AND AUDITORIUM OF THE REGENT THEATRE, SYRACUSE, N. Y.

a triumph of interior decoration. Rich carpets of velvet in blue cover the floor, blending into the old ivory decoration of the walls with their beautiful panels of blue silk tapestry.

The foyer leads across the entire width of the auditorium. Soft tones, indirect lighting and side decorations tend to make the immense space a cozy place. The orchestra seats run down to the stage at an easy angle and the first impression caught in the palace of old ivory and blue is one of spaciousness. The seats are roomy enough for the largest person and so placed that there will be no complaints of knee kinks.

Built in the theatre is a \$10,000 pipe organ, which is augmented by the Regent's well balanced orchestra. The organ fills the space over the private boxes on each side of the house, the bronze gold of the organ pipes adding dignity to the details of the entire interior of the auditorium.

The mezzanine floor is built so as to eliminate the obstructive columns on the

ganzed the University Theatres, Inc., which built the Regent, and he has assumed the management, assisted by M. Straus, treasurer.

WILLIAM A. V. MACK.

NEFF TURNS PUBLISHER

Special to MOTION PICTURE NEWS

Cincinnati, Oct. 14.

Listed among the incorporations at the State Capital, Columbus, Monday, was the Motion Picture Age Company, which will issue a magazine. M. A. Neff is president of the company and identified with him are J. J. Mayer, former editor of the *Billboard*; W. R. Wilson and H. E. Vestal, members of the Ohio State Board of Censors.

The company says its capital will be \$10,000, and that the magazine will be published at Columbus. The *Age* will be a magazine devoted to first hand picture reviews, and the first issue is scheduled to appear early in November.

How Enthusiasm Made a Theatre

By R. E. Pritchard

Snap and Ginger, the Great Business Motive Power, Plus Bright Ideas and Sticking Qualities, Put a Baton Rouge, La., House "On the Wrong Side of the Street" on the Right Side of the Ledger

"WRITE that word in boldface caps and you will have the secret of the success of the Theatre Louisiana, in Baton Rouge, La."

This is the way that the two young men who are operating the newest film house in the capital city of the State described the way they have built up their almost unbelievable success in a single year.

A stock company owns the house, but its management is entirely in the hands of two young men who are thoroughly saturated with enthusiasm. These are P. E. Coe, general manager, and L. H. Grandjean, advertising manager.

There are no harder workers in the capital city and with their industry they can toil, train and lighten the commonplace with ideas.

THESE young men have had a hard fight of it, against the most formidable opposition, but the enthusiasm of the opening day stayed with them—and they have won.

When the Louisiana's beginning was announced, failure was predicted without hesitation. The new house was located on the main business artery, but—"it was on the wrong side of the street."

Cheerful citizens pointed out how others had failed because they were "on the wrong side." There were three other moving picture shows in the city then.

Now there are only two—and one of them is still on "the wrong side of the street," but on the *right side* of enterprise and enthusiasm.

BUT enthusiasm has not been all, for these two young men went into the management of the house well equipped.

Mr. Coe's mechanical knowledge has been a material factor in the success of the Louisiana. His splendid power plant is his particular pet and he gives it his personal attention.

His study of projection has resulted in clearer pictures and he gives the showing of all films close supervision along with the general superintendence of all parts of the management.

Mr. Grandjean, who is in charge of the advertising, is a great believer in publicity in all its branches and his original ideas have resulted in the house rushing to success by leaps and bounds.

"YOU cannot make a success of the moving picture business unless you spend money in advertising; Mr. Grandjean told the MOTION PICTURE NEWS correspondent in outlining the policies the Louisiana had followed to success. He continued:

"We use the local paper daily. Our advertisement is usually six inches single column, but whenever we are using a feature or anything we wish to lay stress on we use a double column advertisement.

"We also use a weekly program in which we list our films for the week,



THE LOUISIANA THEATRE, BATON ROUGE, LA.

together with the principals in the cast. It is a worthy commentary that our competitor follows in our tracks in almost every new departure we undertake.

"WE seldom get out a dodger. These, we have found, are usually stowed beneath bridges or in culverts. If not, they are thrown into a yard and the wind blows them out of the way.

"Our weekly programs, by the way, are distributed at the door of the theatre. I forgot to mention that besides the list of films for the week we print items of interest pertinent to the films listed or advertised as coming, and make little house-talks.

"The mediums are for purposes of specific advertising. It is the kind of advertising you just naturally have to do.

"Another medium of specific advertising is the screen. It is very effective if properly used. We use slides furnished by the exchanges sparingly, as we can make a more effective slide ourselves. I have had sign and card writing and draughting experience, besides some ability at design and cartoons, and I make the slides.

"THE method is simple. To an ounce of Bissell's show card color add an ounce of ordinary lump

prepared chalk, thin with water, and with a soft brush apply smoothly to clean slide glasses. When dry, trace design and lettering lightly with a soft pencil and etch with an orange stick, such as is used for manicuring.

"If you will get thin colored gelatin to cover the wording you wish to stress, and cover the slide with another glass, using binding tape, you will have a very desirable slide. We keep a half dozen or more glasses coated at all times and can 'knockout' a slide in a very few moments.

"This is a feature exclusive with us in our town. Should call come for a physician in the audience, or some person whose presence is urgently required at home, was can shoot a slide on the screen within fifteen seconds.

"However, these things are not unusual and though they are not unexpected in a first class picture show, they help to keep you in the 'live class.'

"BUT no matter what personal touch you may have the power to put into your daily advertising, it is the broader advertising which is going to bring you into the limelight. Do some things that will make the people talk.

"Your indulgence in printer's ink, no matter how forceful and convincing your language, will not suffice to win you spurs as a live wire. We have pulled some stunts that compelled attention.

"And though there was nothing remarkable about any of them, they had the virtue of being unique in this town.

"First in order came a lavish decoration of the building when the Louisiana State University opened for its regular session last fall. We had opened in the summer when the students were on vacation. So, as we were new, we determined to trim in the college and national colors, and thus identify ourselves amongst these eight hundred possible patrons.

"We also had a magnificent drop painted with the big tiger head emblem of the L. S. U. A. A. set in the center as though breaking through the colors of the University. It made an even bigger hit than was anticipated, and made this theatre part of the college life and activities.

"THEN along came the World's Series. Investigation revealed that no one had ever subscribed for the full direct returns in this city. So we had a talk with the Western Union and came away with a contract for full returns with private loop right to our stage.

"We designed and built an electric diamond scoreboard and let it be known

what we intended to do. And, lo! the tongues began to wag. Most of the wagging, however, were 'knocks.'

"Some folks thought we had nerve to suppose that anybody would pay a quarter to hear baseball returns. These same ones kept off the first day, came the second and would have paid a half dollar the third. The thing was incepted as an advertising proposition and we got the kind of advertising you cannot buy, and, besides, it yielded a profit.

"We repeated this stunt on the returns of all L. S. U. football played away from here. On another occasion we hired a circus dare-devil to do perilous trapeze work on a trapeze suspended thirty-five feet above our roof.

"Advertising, yes, we believe in every kind of advertising, every legitimate kind. We use lots of signs, all of our own make. But we positively balk at chalk signs on sidewalks. Ours is the kind to look up to, not the sort to be trodden on.

"WE advertise consistently and truthfully. It does not pay to promise more than you can deliver. We insist on polite demeanor on the part of our employees. We are succeeding because we have been leaders, because we have a properly equipped house, use splendid films, read and absorb most of what's worth while in the trade publications, and devote all of our time exclusively to our own business.

"Our enthusiasm is at as high a pitch today as it was the day we launched the good, old ship Theatre Louisiana."

"TREY O' HEARTS" FILMED AMID DANGER

It is an interesting fact, and one that is not generally known, that, in view of the unusual dangers that attend the production of the "Trey o'Hearts" series, the company is not allowed to leave the studio grounds at Hollywood, Cal., for the purpose of staging scenes in the serial unless they are accompanied by one of the company physicians from the hospital at Universal City.

With him goes an emergency kit complete enough for him to set up a temporary field hospital should the occasion arise.

ALBANY VAUDEVILLE HOUSE OPENS AS FILM THEATRE

Special to THE MOTION PICTURE NEWS

Albany, N. Y., Oct. 14.

The Colonial Theatre, Albany, N. Y., seating 1,800 and originally built for vaudeville, has opened as a motion picture house.

Some of the best film dramas that can be secured will be shown, and it is expected that the promoters will be rewarded by crowded houses.

The first programs have been rewarded with good audiences, and the outlook is favorable.

Washington Official Upholds Exhibitors

Commissioner Siddons Sees in Managers' Previous Stand on Moral Film Questions a Readiness to Show Unbiased War Pictures

Special to THE MOTION PICTURE NEWS

Washington, D. C., Oct. 14.

THE observation of the national neutrality in motion pictures, as requested by President Wilson, was the subject of a discussion recently by Commissioner F. L. Siddons, of the District of Columbia. He said in part:

"We have always found that the operators of motion picture theatres have been ready and willing to co-operate with us in keeping their productions all that they should be from the point of view of morals, and I believe that they will be just as ready to avoid offending in the matter of the spirit of our neutrality.

"It would, of course, be most unfortunate if Washington, the seat of the strongest of the neutral governments, should allow the exhibition of strikingly partisan films which could not but stir up widespread unpleasantness and resentment."

Regarding the position that the civil authorities would have in this matter, the *Washington Post* made the following comment:

"The powers of the commissioners to censor films or to revoke the licenses of theatres under any circumstances are not clear, and become increasingly doubtful when a question of constructive violation of neutrality is involved.

"It is probable that the whole matter will be carefully examined by the corporation counsel, and it is thought that some way can be found to prevent the display of pictures (in most cases 'made in America') that show chapter after chapter of reverses to the 'enemy's' arms, the enemy being varied according to whether the films have a French-

English-Russian or a German-Austrian focus."

From the viewpoint of the exhibitor the agitation of the civil authorities seems to be without due cause. The fact that the films to which reference has been made have previously passed the rigid censorship of New York is proof positive that they should preclude objection.

More than this, many exhibitors early found that the "war films" were too disturbing for the atmosphere they wished to maintain in their theatres. And, in addition, the film fan has acquainted himself with conditions and he is aware that the real war pictures are very scarce, and these are chiefly found in the topical weeklies, which are, as they have always been, very popular.

Motion picture patrons are well aware that photoplays are not enacted on the battlefields no more than the stage setting of "Shenandoah" is expected to be the true location of the Civil war campaign.

That war photoplays find favor at present is but natural, but these are chiefly historical, or imaginary when they refer to European countries, and a great number are of our own struggles. Those that point to the unnecessary destruction of war, the misery and desolation caused by such strife, and the boon of reconciliation and peace cannot fail to work a moral good.

Neither the motion picture manufacturer nor the exhibitor has any desire to violate the neutrality of the United States, as both are aiming for the uplift and entertainment of society, and not its dissolution.

THEODORE FRANKLIN.

Producer Deplores Newspaper Attitude

Edgar Lewis Says Dailies Use War "Stills" More Apt to Excite Race Feeling Than the Average Military Photo Drama

EDGAR LEWIS, producing director of two multi-reel war photoplays being exhibited in New York, while approving the attitude of the German-American Chamber of Commerce with respect to the production and exhibition of "faked" scenes of "atrocities" on the screen, insists upon the right of film manufacturers and the National Board of Censorship to determine what may be distasteful to motion picture audiences.

"While I deprecate the exhibition of pictures showing 'atrocities' or horrifying scenes," said Mr. Lewis, "there is no reason why the manufacture of battle scenes should not be continued.

"Any spectator with red blood enjoys a cavalry charge whether at military manoeuvres or on a screen; all of us like to see marching infantry either on Fifth avenue or in the theatre; and as long as pictures do not lead to expressions of partisanship on the part of the

audience there is no reason why a public official should interfere.

"Daily I have seen in the public press 'still' photographs of war scenes with captions and graphic descriptions beneath which showed that the paper was not unbiased; in store windows throughout the city I have seen views of the Germans 'tearing their way through the Allies' lines,' and of Scottish Highlanders and French cavalry 'decimating the ranks of the Imperial German Guard and the Uhlans.' All of which pictures, it is needless to say, were taken from six months to four years ago at manoeuvres.

"If the newspapers are permitted to print pictures showing war or alleged war scenes, and I do not deny their right to go as far as they think best, why should moving pictures of the war be barred when pains are taken to offend none of the belligerent nations?"

PRACTICAL ORGANIZATION FOR CITY EXHIBITORS

P. Rosenson, an Exhibitor of Wide Experience in His Own Field and a Thoughtful Observer of General Business Conditions, Advocates Plan for Greater New York Managers to Combat Adverse Legislation Which Might Be Solution of a Difficult Problem

THE following letter from P. Rosenson, manager of the Greenpoint Star Theatre, Brooklyn, N. Y., a man who has a wide knowledge not only of the motion picture industry but of business conditions generally, will be of interest to exhibitors throughout the country.

Mr. Rosenson, who does not believe in an organization policy which shall result in an association entering into politics for obtaining the results necessary to solve matters affecting the rights of exhibitors, has outlined a plan which demands the serious consideration of every owner of a motion picture theatre. The details follow:

I am opposed to the organization affiliating with any political faction. As a civic body we ought to be stronger than a political faction. As a body of exhibitors we ought to be stronger than any other civic body.

I am opposed to anyone who says, "I know senators by their first names. I want some funds of the organization so that I may go to the state capitol and tell them I want favorable legislation."

Such a course has always proven ineffective. If the plan I have laid down, which will be explained later, is followed, such a course will be unnecessary.

I am opposed to the organization requesting members to show partisan political slides. In my plan I will make it clear that our activity in politics will be to defeat those who oppose us in legislative matters, but not to affiliate with any political faction. In other words, we should demand legislation on pain of defeat of those who are against us.

Plan of Reorganization

I am opposed to the organization's favoring benefits at the request of officials who have discretionary powers to injure our business. It savors of petty bribery, and it would tend to weaken the organization.

With a view to remedying these conditions and mainly for the purpose of procuring favorable legislation and combating adverse legislation, I have laid down a plan of re-organization, embodied in a constitution and by-laws which I have drafted and which were approved at a meeting of exhibitors by no less than 250 members attending, and which is now in effect.

We would now have been on the high road of a strong Greater New York organization if we were not interrupted by an attempt to amalgamate the two Greater New York factions. (I happen to be the chairman of the Amalgamation Committee of the I. M. P. A. faction.)

Here is the plan of reorganization. In other words, this is the constitution and by-laws which are in effect, but will not be enforced until after the election of officers.

Greater New York is divided into senatorial districts. Each district will elect a chairman who will be known as the executive member of the district and will be the representative to the executive board.

The ruling body will be an executive board consisting of officers elected at a general meeting of all the members of the association, and of the representatives from each senatorial district. There will be a general president and a vice-president from each borough, who will be president of the members of his respective borough.

How It Works Out

Regular meetings of the general association (of all the members) will be held quarterly. Meetings of the executive board monthly. Meetings of districts monthly.

Benefits for members are provided for, such as free service of counsel, etc.

All details necessary to conduct an unselfish organization are fully provided for.

It will be observed that each senatorial

district consists of three aldermen, three assemblymen, one state senator and one congressman. If legislation is required it is the duty of each executive member (senatorial district chairman) to go to his alderman, assemblyman or congressman, whichever the case may be, and tell them or him that he (the executive member) is charged with procuring favorable action from the legislators of his district.

Should any legislator vote against exhibitors' measures, an investigation will be made to find out if the executive member has neglected his duty, and if found delinquent he will be replaced by another executive member. If, however, the legislator has defied the exhibitors, it will be the duty of the executive member to endeavor to defeat his election. It is understood that the executive member has the backing of the entire organization.

It is reasonable to believe that under these arrangements not only will legislation be procured on its merits, but it will tend to strengthen the organization for social and other beneficial purposes. The incentive lying in the numerous offices it will distribute. (Twenty-five chairmen, four vice-presidents, and many other offices and committees.)

Dayton May Agitate for City Lighting Plant

Exhibitors Make Accusation of Rate Discrimination by Local Light and Power Company—Company Promises an Answer

Special to MOTION PICTURE NEWS

Dayton, O., Oct. 14.

INCENSED at the alleged discrimination against various motion picture houses of the city, the local branch of the Exhibitors League has announced its intention of joining in the agitation for a municipal electric lighting plant unless the Dayton Light & Power Company grants a uniform and reasonable rate for electric power to all theatres.

According to members of the league, rates to the motion picture houses vary from two cents a kilowatt hour to nine cents per hour. A downtown theatre gets this lowest rate, while exhibitors in outlying sections are compelled to pay the higher rate.

The Dayton film men say they might use their screens in a combined movement to foster the idea of a municipally owned plant, unless action is taken to relieve the situation, and arrangements are being made to call a meeting of the league members to consider the matter.

At a meeting during the past week of the exhibitors' organization, a committee composed of Wm. Hemsteger, of the Royal; Julius Leopold, of the Mecca; Sherman Coarse, of the Soldiers' Home

Theatre, and Bert Fiala, of the Alhambra, was appointed to interview officials of the local electric lighting company in regard to a uniform rate for electric power to motion picture houses of the city. The lighting company received the delegation in good spirit and promised to give an answer this week.

Results are already apparent today. Agents have been sent out by the lighting plant for the purpose of securing data on the amount of current used by the respective theatres, number of lights, etc. A coming vote at the hands of the people on the question of a \$500,000 bond issue for a municipal lighting plant has a bearing on the situation.

FAILS THROUGH LACK OF EXPERIENCE

Special to MOTION PICTURE NEWS

Syracuse, N. Y., Oct. 14.

The New Simpson Theatre, located two blocks from the Regent, and at the top of University Hill, closed its doors after operating five days. Mr. Simpson contemplates leasing the house, as he is not an experienced film man.

JERSEY BLUE LAWS WORK HARDSHIP

Sunday Closing Results in Newark Motion Picture Patronage Going to New York City, Where Theatres Are Permitted to Remain Open on That Day—Exhibitors Realize Need of Strong Organization to Amend Statute in Their Favor

Special to MOTION PICTURE NEWS

Newark, N. J., Oct. 14.

Need of a strong state-wide organization of motion picture exhibitors has never been more keenly felt in this city than it is today.

Newark, it seems, may be a battle ground on which will be fought out a question of vital importance to the film men throughout the State—whether or not Sunday performances shall be permitted under the law. They are not today, although Sunday amusements which are far more objectionable in character are allowed to go on without interruption.

Impelled by increasing competition and a noticeable falling off in business consequent to general commercial and industrial depression brought on by the European war, a little group of men directly interested in local amusement enterprises is determined to force the question to an issue.

This will mean carrying the fight into the state legislature, for to legalize Sunday picture shows the Assembly and State Senate will have to amend the old Blue Laws which are still in force in New Jersey.

Campaign Against Blue Laws

The campaign started about a month ago. It was started by Sigfried Leschziner, a prominent real estate operator. Mr. Leschziner is a member of the Chelsea Securities and Investment Company, which controls the Paramount theatre, Broad and Hill streets, probably the highest class motion picture house in the city. The concern also controls the Orpheum theatre, devoted to stock productions.

Associated with Mr. Leschziner in the Sunday opening movement were several other men prominent in the local motion picture business, among them Emil Gerstle, manager of the Strand theatre, the most beautiful motion picture house in the city.

A meeting of the managers was held in Mr. Leschziner's office. Many of them responded to the call and heartily indorsed Sunday opening. Other meetings followed and a committee was finally appointed to take the matter up with the authorities.

State Organization Needed for Fight

A conference was held with Chief of Police Michael Long. The chief admitted that he did not see any harm in Sunday picture shows, but he said there was a law against them and he was drawing pay to enforce the law.

He advised the committee to take its troubles to the state legislature and try to have the law revoked. There the matter stands for the present, but it will not

rest long if the backers of the movement have their way.

But the Newark exhibitors stand alone in their fight. They can not fall back for support on a powerful state organization. To wage a propaganda for Sunday theatre opening will cost a lot of money, for it will probably be hotly opposed.

Where the money is coming from is a question, for to try to raise the necessary financial support from individual exhibitors would be like hunting for hen's teeth.

Sentiment among the managers has been carefully sounded by the representative of MOTION PICTURE NEWS. Without exception, all who were interviewed declared themselves strongly in favor of Sunday opening. Some went so far as to say that they absolutely had to have the extra day to make both ends meet.

"We don't think there is anything objectionable in people going to the theatres on Sunday," said Mr. Leschziner.

"In cities of churches like Brooklyn and New York City, the theatres are allowed to have Sunday performances, and they are not harmful.

Want to Keep Money in Newark

"This town is closed tight on Sundays, and as a result between \$50,000 and \$100,000 goes out of Newark into New York each week. The theatre people

are injured directly, and all of the tradesmen and property holders in the city are hurt indirectly. If our theatres are open on Sunday we will give the people something to stay home for, and we will keep Newark money in Newark.

"Many of our motion picture houses pay heavy rent and enormous taxes, and the rent and taxes run on Sundays just as well as week days, and the theatre men have to pocket their losses.

"We don't want to run 'humpty dumpty' shows, but clean decent performances, which certainly do no harm, but on the other hand, give people harmless amusement and keep them away from more objectionable pursuits.

"But the law does not permit us to give these entertainments, and we don't want to violate the law. The next thing to do is to amend the statutes. I would like to have this question submitted to a referendum of every theatre-goer in the state.

"I think we ought to have some help from the film corporations. It means a lot to us, but the benefit to them can not be overlooked.

"I have spent some of my money and more of my time pushing this thing along. We have got it now to the point where it has got to be made a state-wide, public movement, and how we are going to carry it through, I don't know." JOHN W. HAWKINS.

Colonial Stockholders Hold Meeting

James D. Law Elected President to Serve One Year—Fifteen Directors Put on Board for Next Twelve Months

AT the annual meeting of stockholders of the Colonial Motion Picture Corporation, held on October 5, the present management was sustained by a vote of nearly two to one, and the following fifteen directors were elected for the ensuing year:

Professor Arthur Beatty, Madison, Wis.; James J. Booth, Pittsburgh, Pa., vice-president, Oakland Savings and Trust Company, director, Commonwealth Trust Company, and director, Commercial National Bank; F. C. Brooksbank, Riverton, N. J., former president, Brooksbank-Tillingast Sand-Blast Company, of Philadelphia; Frederick S. Dudley, New York City, vice-president and general manager of the company; J. Watson Hayden, Troy, N. Y., treasurer, Fellows and Company; Robert T. Herrcke, La Salle, Ill., hardware merchant; James D. Law, New York City, president of the company; Duff C. Law, Wissahickon, Pa., technical director of the company; Edwin H. Meyer, Evansville, Ind., president, Newman Plumbing Company, secretary and

general manager of Meyer Candy Company, proprietor, Highland Poultry Farms; W. T. Saxton, Delta, Ohio, vice-president, People's Savings Bank; Max R. Taylor, Port Chester, N. Y., merchant; Herbert W. Taylor, secretary-treasurer of the company; C. W. Tannant, Amston, Conn., scientist and lecturer; Jesse Watson, New York City, attorney-at-law; Richard Wightman, New York City.

This board of directors has elected the following officers to serve for one year: James D. Law, president; Frederick S. Dudley, vice-president and general manager; Herbert W. Taylor, secretary and treasurer, and C. Anhof, assistant secretary.

FILM AIDS TEMPERANCE

Special to MOTION PICTURE NEWS

Lexington, Ky., Oct. 13.

The "John Barleycorn" film has been shown in Lexington, Ky., under the auspices of the prohibitionists who are making a vigorous fight in the local option campaign in Fayette County.

Milwaukee Exhibitors Will Not Disband

Members at Meeting Held in Plankington House Decide to Stand Shoulder to Shoulder and Make Strong Fight Against Adverse Legislation—Twelve Hundred Dollars Subscribed to Finance Ball—Photo Play Put On at "Legitimate" House Draws Capacity

Special to MOTION PICTURE NEWS

Milwaukee, Oct. 14.

NOT only is the Motion Picture Association of Milwaukee not going to disband, but it is going to enter into the fight against adverse legislation and for better co-operation among the exhibitors with greater vigor than ever. This was decided at a meeting held at the Club Room of the Plankington House.

It was a record breaking meeting in all respects, over fifty per cent. of the members being present; great enthusiasm was displayed by the exhibitors.

It was decided to hold another ball this year, owing to the wonderful success of last year's ball, an affair that was termed "the model ball of the season" by Manager Grieb of the Auditorium.

Twelve hundred dollars was subscribed by the members to finance the ball and twice the amount would have been available if it had been desired. The lists were closed two minutes after the call for funds was made. The list of those donating and the amounts are as follows: James Cochrane, \$500; Henry Trinz, \$200; Tom Saxe, \$200; C. H. Phillips, \$50; B. K. Fischer, \$50; George Fischer, \$50; J. H. Silliman, \$50; Col. Pruesser, \$50, and Otto Andries, \$50.

Money for Preliminary Expenses

This money is desired merely for the preliminary expenses of the ball and will be returned to the donors after the ball. The purpose of this ball is not only to advertise the motion picture industry as a whole to the people of Milwaukee, but to raise funds to conduct the fight against adverse legislation at Madison this winter.

A governing committee on the ball was appointed which will have full charge of all arrangements and the conducting of the ball. The committee is composed of George Fischer, Henry Trinz and J. H. Silliman. Henry Trinz was also appointed treasurer of the fund.

A letter was read from James Sherwood, president of the Wisconsin Photoplay Association, calling upon all members for their support in the movement and asking them to work for two hundred members—the mark the officers have set for the coming year.

Everything points to a wonderful rejuvenation of the interest in both the state and city organization, many members who have heretofore been considered unapproachable having signified their intentions of joining either one or both of the organizations.

Motion pictures have again put a

crimp into the box offices of the "legitimate" and vaudeville houses and demonstrated their superiority as a business getter, even when shown at a house that was long considered impossible for anything but German stock and concerts.

Film Drama Mentioned Editorially

"Neptune's Daughter" is the photoplay that has put over the impossible this time. It was booked for the Pabst theatre recently with the hopes that it would at least pay the rent of the theatre while it remains idle, waiting for the opening of the German stock. It was realized, however, that the picture was going to do more than just pay the rent and all week long it played to capacity houses.

And not only did it play to capacity houses all week, but the Davidson Theatre, Milwaukee's only legitimate two dollar house, bowed to film drama and booked the picture for a solid week, leaving Milwaukee without any big attraction. But this was not all. The Free Press devoted an editorial to the production, something that has never

or seldom been done for a theatrical attraction, let alone a photoplay.

Naturally, the theatre men were a little upset over the affair, as the Pabst was the only house that played to capacity during the week, and they are waiting in fear and trembling for the next blow from the formerly despised motion picture.

The placing of "Neptune's Daughter" at the Davidson and the booking of "Cabiria" at the Pabst left but two burlesque houses, two vaudeville and a stock house outside the ranks of motion pictures, a rather peculiar situation in a city of 400,000 people.

The wonderful success of "Neptune's Daughter" but demonstrates the opening there exists in Milwaukee for a twenty-five cent feature house, playing but four times a day for week stands. It would not be surprising to have some outsider come into the city and establish a feature house of this kind, as the big local exhibitors seem unwilling to open this sort of a house, though they all admit that there is room for one.

J. W. MARTIN.

Minnesota Association to Have Exposition

Organization Is Assured of 300 Exhibits by Manufacturers of Films and Equipment at Its Convention—Program for General Public

Special to MOTION PICTURE NEWS

Minneapolis, Oct. 13.

A MOTION picture exhibition, aimed to bring the theatre-going public together on better terms, and to show the progress of the business, will be conducted by the Motion Picture Exhibitors' Association of Minnesota on October 27, 27 and 29, in the West Hotel, Minneapolis.

The exhibition which the association officers hope will rival those conducted in connection with the national conventions, will be in conjunction with the first semi-annual convention of the association. Already the association is assured of three hundred exhibits, and the program has been made to appeal to the general public as well as the exhibitors.

There were some scoffers when Harry Green, president of the association, and W. A. Steffes, secretary, proposed such an exhibition. Some believed that it was too big an undertaking for a new state body.

According to these men who have had the direct management of it, however, every member has given unreserved support, all have gone into the game, and the result is that the exhibition will be one of the big events of the fall for the Northwest.

All the exhibitors of the Northwest have been invited to join in the big time,

and many manufacturers of films and equipment have taken space.

The lobby of the hotel has been turned over to the exhibition, and the second floor as well will be used for the exhibits.

One feature will be a continuous exhibition of films to the exhibitors. Educators, city officials and professional men will attend, and have an opportunity, if they don't already know, to learn the sort of business men that are furnishing the entertainment for 80 per cent. of the Minneapolis population.

When the members are not entertaining, teaching or learning for themselves, they will boost for the state organization. Any exhibitor who attends this convention and gets away without lining up for film progress will have to be mighty smooth or mighty mean.

Governor A. O. Eberhart, Mayor Wallace G. Nye and other officials will cooperate in making the convention and exhibition a success.

FARNUM BACK ON THE COAST

Dustin Farnum, who has appeared in two pictures for the Jesse L. Lasky Feature Play Company and who has been summering at Bucksport, Me., is back at Hollywood, Cal., where he will again appear under the Lasky banner, in the Lasky-Liebler production of "Cameo Kirby."

"BELOVED ADVENTURER" MAKES BIG HIT

The success of the Lubin Serial, "The Beloved Adventurer," is beyond expectations. Five of the stories have been released so far and the cry is for more.

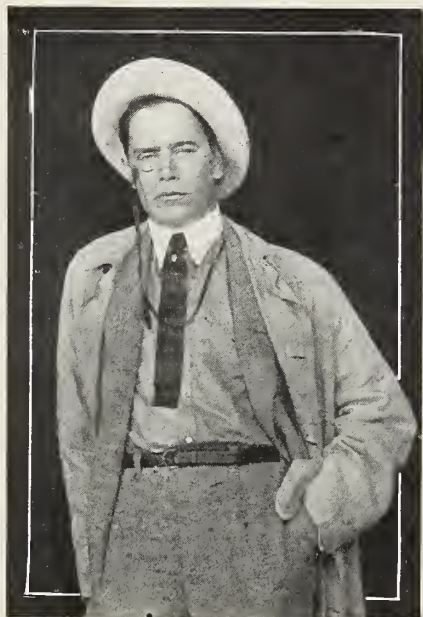

ARTHUR V. JOHNSON
Lead in the "Beloved Adventurer"

The enormous sale of the book, which tells the adventures of the good Lord Cecil in novel form, has created a universal desire to see the pictures. The output of the Monday feature has more than doubled any other single reel that the Lubin company has ever released.

TOOKER CAST FOR THE LEAD IN "SPRINGTIME"

The Life Photo Film Corporation's forthcoming release, "Springtime," a screen adaptation from the stage play by Booth Tarkington, is in active preparation.

William H. Tooker, who played the lead in the prior releases of the company, will take the lead in this production.

As the result of his work in "The Greyhound" and "Captain Swift," Mr. Tooker has been inundated with offers from motion picture feature manufacturers. Mr. Tooker, however, is under a long contract with the Life Photo Film Corporation and will continue to take the leads in their productions.

KANSAS MAN AFTER EXTRA PRINTS OF "MYSTERY"

Special to MOTION PICTURE NEWS

Omaha, Neb., Oct. 13.

Sol Burman, special representative of the Syndicate Film Corporation at Kansas City, was in Omaha recently.

He says he had to call on the New York office for more extra prints of the "Million Dollar Mystery" even at this late date. The serial has set a new record for such features in this territory, he says.

Milwaukee Films Turn Flank of "Legit"

Only One Two Dollar House Open—September, Formerly Its Best Month,
Finds Theatre Dark Part of Time

Special to MOTION PICTURE NEWS

Milwaukee, Oct. 13.

THE one dollar and fifty and two-dollar attractions have almost become a nonentity in the local amusement field. Ever since the advent of the motion picture as a factor in the theatrical business the high price attractions have been losing their grip on the theatre-going public until now there is but one house in the city playing high price attractions. This is the Davidson, which is having anything but an easy time of it.

This year for the first time in the history of the house it was dark during September.

This is an unusual situation in view of the fact that the fall is usually considered the best time for theatre attractions, and capacity houses have been the rule all over the city in the cheaper priced theatres and the motion picture shows.

The last attraction, a big New York musical comedy, played to houses that were but half filled downstairs, all during the first half of their week's engagement, despite the fact that the newspaper criticisms were very favorable to it.

In face of the poor showing of our one two-dollar house comes the announcement from the Alhambra Theatre that the new twenty-cent scale is proving very satisfactory and that the business is increasing rather than decreasing as some said it would.

In fact, the whole downtown photograph theatre situation is taking on a more prosperous aspect. Though the Alhambra is the only house to advance its prices it is expected that a number of the nickel houses may come up to ten cents very shortly, as at present the Butterfly is the only house that is getting a straight ten-cent admission rate.

J. W. MARTIN.

Cleveland Judge Endorses Motion Pictures

No Cases of Juvenile Delinquency Traceable to Films, Declares Addams Before
Exhibitors' Meeting—Neff Reports Protest on War Tax

Special to MOTION PICTURE NEWS

Cleveland, O., Oct. 14.

TWO important matters were brought to the attention of the Cleveland theatre owners on October 8, when the Motion Picture Exhibitors' League No. 1 convened in its regular meeting.

M. A. Neff, president of the Exhibitor's League of Ohio attended the meeting and called the assembly's attention to the protest he has registered with Secretary of State Bryan, Senator Atlee Pomerene and other statesmen, against the proposed war tax on picture theatres.

The exhibitors recommended that the state executive committee decide upon January, 16 and 17 as the dates for the convention to be held here, so that concerted action can be decided upon in advance of bills to be presented in the legislature.

The second matter of importance was the vindication given the theatres of

the charge of contributing to the delinquency of children. Judge Addams of the Juvenile court and T. L. Lewis, chief probation officer of that court, spoke in vindication of the motion picture theatre.

Sifting down the cases which had come before them, the two men declared that few of them were traceable to the picture show, and these few only indirectly.

"The picture show has the power to do either evil or good," Judge Addams said. "The screen is now, and as time advances will come more and more in use as an educational device."

"The motion picture exhibitor can and does perform his share in social advancement. The quality of films exhibited is high, and in the main there can be no criticism."

Mr. Lewis found his only complaint in the lurid poster, which he declared the exhibitors are gradually eliminating.

ORSEN N. NIELSEN.

Alco Establishes Exchange in Dallas

Branch Will Serve the Territory Embracing Texas, Oklahoma and Arkansas
—A Full Atsco Line Also to Be Carried

THE Alco group of exchanges, now well over twenty, has been increased by the addition of one in Dallas, Texas. The Alco youngster is the Alco Film Corporation of Texas, and is located at 1902 Commerce street, Dallas. The territory served by the new exchange embraces Texas, Oklahoma and Arkansas.

In addition to handling the releases of Alco, the Alco Film Corporation of Texas has a full line of the allied Atsco Company's motion picture theatre sup-

plies, including the world famous Radium Gold Fibre screen. Its use will increase now that exhibitors can secure it without the delay incidental to ordering it from an exchange further away.

The Alco Film Corporation of Texas keeps constantly on hand the latest releases of Alco, which include the productions of the All Star Feature Corporation, the California Motion Picture Corporation, the Popular Plays and Players Company, the B. A. Rolfe Photo Plays, Inc., and the Tiffany company.

LIVE WIRE EXHIBITORS

EDITOR'S NOTE.—It is the desire of "The Motion Picture News" to include under this heading novel advertising ideas, successful schemes in the management, decoration and equipment of the theatre—everything, in fact, done by the exhibitor to stimulate his trade. We invite every exhibitor to write us about any new enterprise he has; also to come to us for advice or information along any line. Address: Editor, "The Motion Picture News," 220 West Forty-second Street, New York City

HOW ADVERTISING MADE A THEATRE

WHAT may be done by a little judicious advertising and the presentation of high-class films, to boost business, is shown by the history of the Winter Garden Theatre, Rochester, N. Y.

For some time as Fitzhugh Hall, the theatre, tried to struggle along, but the promoters could not make a go of it, and went into bankruptcy. Then the property was taken over by the General Theatre Company, of Buffalo, of which J. A. Schuchart is president, and for the past month has been doing a lively business.

The name was changed from Fitzhugh Hall to the Winter Garden. The theatre was redecorated and other minor changes made. J. A. Kelly was put in charge as manager, and opened the house with a three weeks' run of "Neptune's Daughter," featuring Annette Kellerman. Since then the theatre has been producing features, changing twice weekly, at ten cents admission. In some cases the features are ones that had been seen here before, in another section of the city, but most of the pictures shown are first run in Rochester.

Recently Edgar L. Weil, one of the best-known men in the motion picture business, came down to take charge of the house.

Mr. Weil has had six years' experience in motion pictures, and before that conducted penny arcades. He was the first to conduct a really big picture house in New York, the Unique, on Fourteenth street. He put in three years running the Strand, in Toronto. Mr. Weil has just recovered from an illness of six months, this being his first assignment since he was taken sick.

PROFUSELY ILLUSTRATED INSERT FOR CATALOG

THE progressive management of the Lehigh Orpheum Theatre, South Bethlehem, Pa., has added a feature to its program which has attracted considerable attention. Besides the usual list of coming bills and press clippings for "between-the-acts" reading the booklet contains a six-page insert illustrated with half tones having a detailed story of the play. This instantly catches the attention of the patrons.

PROFITING BY LOCAL PATRIOTISM

MANAGER FRANK HARRIS, of the Empress Theatre, Sixteenth and Douglas streets, Omaha, finds public-spiritedness to be one of the steps to success. The accompanying photograph shows the Empress as it was decorated during Ak-Sar-Ben (Nebraska spelled

must know that the flags shown in the picture are either red, green and yellow (the carnival colors), or the red, white and blue of the country's flag. Around the entrance the myriad of lights were also in the carnival colors, and the scheme was carried out in the interior decorations.

Manager Harris was one of half a dozen business men in his block who banded together and paid a big brass band to play along the block several times daily during the week. Did it help? Of course, it did.

"I had this picture taken to show the decorations, not the crowds," said Mr. Harris. "Had I wanted to, I could have shown the sidewalk filled with people and the crowd extending into the street."

During the week extra shows were put on in the morning. All the local theatres did that, and were filled. Manager H. W. Cowduroy, of Elite No. 2, 1318 Farnam street, said his theatre was filled with some of the largest crowds he ever had. All the exhibitors made special efforts to put on pictures that would be the most entertaining to the visitors.

It is safe to say when the visitors left Omaha they did so with a distinct impression of the progressiveness of the Omaha motion picture exhibitors, among the leaders of whom is Manager Frank Harris, of the Empress.



THE EMPRESS THEATRE, OMAHA, IN ITS "AK-SAR-BEN" ATTIRE

backward) week in Omaha. This is the big fete season of the State, and tens of thousands of visitors come to Omaha.

To appreciate the actual sight, one

BOOSTING ATTENDANCE WITH PRIZES

SYLVESTER GROVE, manager of the Preston Theatre, and one of the live wire exhibitors in Louisville, Ky., has hit upon a plan which has greatly added to the revenue of his house.

Some time ago Mr. Grove noticed that the attendance on Saturday nights was extremely light, despite the fact that he thought it should be one of the best.

He came to the conclusion that people in his section were probably going to downtown theatres on Saturday, and set about to find a way to bring them to his house.

He began a system of giving prizes to every woman who attended the show on Saturday night. The attendance increased quickly.

The prizes, or souvenirs, given away consist of household articles. Every woman purchasing a ticket is given another ticket which entitles her to some article.

Before trying out this scheme, Mr. Grove says Saturday night was the worst night of the week. Now, it is one of the best. "The giving of souvenirs," he says, "is what made Saturday night for me, and although it has increased my expenses, it has increased the receipts so much as to make it worth while. I think it is a good proposition for any exhibitor to try if he has a 'bad' night to contend with."

Prizes for women cannot fail to draw big, no matter what a manager uses so long as it is something free.

**"BE A WOOLZY"—SOME LIVE
ADVERTISING**

MANAGER FRANK HAWKINS, of Los Angeles, to advertise "The Patchwork Girl of Oz," secured the original beast known as the Woolzy from the Oz company, placed it on a big truck gaily decorated with banners, and put on a fairy land parade, which created amusement wherever it was seen. The beast received considerable publicity. One newspaper, the Los Angeles Tribune, which carries a regular motion picture department, published a half column double story with a big half-tone picture under this heading:

Woolzy? Seen it? Do not stare
At this funny thing so square,
Born in Cubist Artist's Lair.

This is Noted Woolzy Beast,
Can be seen at Alhambra Feast.
Of Screen Plays it's Not the Least.

The news story concerning the parade of the Woolzy followed this bit of verse:

The Woolzy is a funny beast,
With most peculiar habits,
He lives on unfermented yeast,
And little Easter rabbits,
A Cubist artist's wildest dream,
Could picture nothing rarer,
The Woolzy is a cubist scream,
For nothing could be squarer.

This is the Woolzy from Woolzy town,
He has no hair and his skin is brown,
His eyes are filled with a cheerful stare,
To be a Woolzy you must be SQUARE.

The Woolzy soon his ears will flap,
Upon your radiator cap,
And there he sings his little ode,
"Be square and give me half the road."

The Woolzy opens his cubist mouth,,
And has the children "going south."
But though he's ludicrous, beware,
The Woolzy's always On the Square.

A company of Los Angeles business men has been formed and they will have miniature woolzies manufactured of wood, which will be placed on the market as toys. It is believed they will become as popular as the Pensive Pup, Kewpies and other novelties.

**UNITED PROGRAM COMPANIES
HAVE LIVELY COMEDIES**

The producing companies which form the united program, to be released through Warner's Features, are already at work and have turned out a few one-reel subjects. The Premier and Superba brands have each produced a comedy and another company whose name has not yet been decided upon has made two.

A number of well-known faces will appear in the pictures of these various companies, among them being Charlie De Forrest, one time the leading man of the Crystal pictures which are released through the Universal program. He appears in his same funny role.

The old Frontier company, or part of it, is appearing under the Premier brand. Willis Robards is director, and his leading men are Joe Franz and Arthur Allardt.

These pictures together with Dot Farley and the Albuquerque company form the nucleus of the program, which will shortly be ready for release.

"Hoosier Schoolmaster" Proves a Masterpiece

Clawson-De La Parelle Production, by the Masterpiece Film Company, Shown on the Coast to Enthusiastic Audience

Special to MOTION PICTURE NEWS

Los Angeles, Oct. 12.

MORE than one thousand people, State rights buyers, exchange men, exhibitors, photoplayers, and their friends were the guests of the Masterpiece Film Company, Friday evening, October 2, and witnessed the first showing of the company's initial production, "The Hoosier Schoolmaster," from the new famous Indiana pioneer days' story

and threats, Ralph decides to stay and organize his "Church of the Licks."

When his pupils fail in their attempts to drive the schoolmaster out of the district the patriarchs undertake the job under the leadership of Pete Jones (W. R. Walters), a politician. The responsibility of a grave crime is fastened upon Ralph. Crowds gather and public sentiment runs high. There is always a crowd of men waiting with a



LOLITA ROBERTSON AND MAX FIGMAN
In "The Hoosier Schoolmaster" (Masterpiece Film Company Feature)

by Edward Eggleston. The picture was arranged and produced by M. de La Parelle, assisted by Elliott J. Clawson, consists of five reels and notwithstanding the name of the company, is entitled to being classed as a masterpiece on its merits.

Ralph Hartsook (played by Max Figman), a bookish man with a high sense of moral obligation but "not much in a tussle," goes to Flat Creek district. There he meets Hannah Thompson (Lolita Robertson), a girl educated beyond her surroundings, of a retiring disposition, who is bound out as a servant in the Means household. She is made a slave by the brutality of the family. Ralph sees beneath the soiled clothes the "Queen of the rosebud garden of girls."

Conspiring Mrs. Means takes Ralph into the family with the intention of making a match between him and her daughter, Sis. Mrs. Means detests Ralph as a schoolmaster, but would boast of him as a son-in-law.

From the day of his arrival the schoolmaster is looked upon as the natural enemy of the Flat Creek people. Bud Means (Roy Stewart) is the champion schoolmaster-hater. But despite rumors

rope to lynch a man when he is down, and so was there in Flat Creek.

Captain Pearson, who "fit with Gen. Scott at Lundy's Lane," proved a friend in need; Bud Means joined the "Church of the Best Licks" at the last moment, and at the trial Pete Jones, by an unexpected turn of events, was branded as the guilty party.

Frank C. Hill, secretary and treasurer of the Masterpiece company, is in New York, where he will give an exhibition of the picture and arrange for State rights and books. The release date for the picture is October 22.

**FINNEY OPENS EXCHANGE IN
ARIZONA**

Special to MOTION PICTURE NEWS

Denver, Oct. 13.

J. C. Finney, of Denver, formerly connected with that branch of the Mutual Film Company, has gone to Phoenix, Ariz., to take charge of a branch exchange his company is establishing there.

He is thoroughly conversant with the motion picture business in all its branches. He will cover from his office the Arizona and New Mexico territory.

Directory of New Theatres

EDITOR'S NOTE.—The information contained in the "Directory of New Theatres" is gathered by the field representatives of "The Motion Picture News" and the facts and figures in each instance have been verified by them and are authentic. They may be relied upon by members of the trade.

\$200,000 THEATRE FOR NEW HAVEN

NOTWITHSTANDING that trifling technical points of law have thus far prevented the obtaining of a building permit (which in any event must be forthcoming in the near future), the Gordon Brothers, heads of the large theatrical syndicate, have commenced work on the new \$200,000 theatre they are to erect here, and have already broken ground on the historic old Robinson site at the corner of Temple and Crown streets, New Haven, Conn.

When completed—early next year, it is hoped—the theatre will be one of the handsomest, best and most modernly equipped in Connecticut, if not in New England. Plans have been in the hands of the building inspector for some time, and are to stand with the exception of a few slight changes in the front elevation.

According to these plans, the building will be two stories in height, of brick construction with marble front, lobbies and stairs, and will be in "L" form. The portion of the structure facing on Temple street (in which will be two stores and the main public entrance to the theatre) will have a frontage of 78 feet by a depth of 136 feet. Adjoining this, with a frontage of 82 feet on Crown street, will be part of the theatre proper, 100 feet in depth. This gives the theatre itself a total depth of 178 feet.

The house will have a seating capacity of about 1,500, with orchestra and one balcony. Details of the interior decorations have not yet been made known. There will be a large stage, 82 x 36 feet, while the two stores in Temple street will measure 24 x 60 and 18 x 60 feet, respectively.

No official announcement has yet been made as to what the policy of the house will be, though it is understood that the Gordon system of combined vaudeville and motion pictures will be used. At any rate there is assurance that moving pictures will play a more important part in the new theatre than legitimate.

The construction of the building is in the charge of the David H. Clark Company, local contractors. L. W. Robinson is supervising architect, acting in behalf of C. H. Blackwell, designer of the building, of 20 Beacon Street, Boston.

Its location speaks well for the suc-

cess of the new Gordon Theatre. It is in the heart of the business district, and on the site once occupied by the famous Robinson homestead, one of New Haven's historic landmarks. The house was purchased by the Gordons and torn down to make way for the theatre.

BIG THEATRE IN ROCHESTER

THE first authoritative announcement concerning the plans of the owners of the new East Avenue Theatre, Rochester, N. Y., which has been in course of construction since last spring, has been made by George E. Simpson, a member of the corporation which is building it, and the manager of the enterprise.

The theatre is to be known as the Regent. It will operate on a high class scale, showing the best pictures and the highest priced features in the market, yet at a reasonable admission fee. The management has already contracted for the Paramount picture service.

Prices in the new house will range from 10 cents up. The theatre, which is now nearing completion, will be ready to open its doors about December 1. The work of decorating it has begun, and only the placing of the seats and other equipment remain to be done once the artists have completed their decorative work.

Every modern feature is to be found in the theatre, says the architect, Leon H. Lempert. Its seating capacity will also be greater than that of any theatre in this part of the country.

The theatre has an exceptionally large seating capacity on the ground floor, and, in addition, has a spacious balcony. The projection booth will be located in the center of the balcony, thus giving a short projection distance, which makes for clear pictures.

A big feature is the promenade which has been provided on the mezzanine floor, in the rear of the balcony. It is large and will be prettily furnished. Retiring and smoking rooms will open off it.

The Regent has a stage, equipped for producing vaudeville or regular attractions, but will show only pictures. There is a large organ, half being located on each side, over the boxes. There will be a large number of box and loge seats.

TWO MORE IN GALESBURG

THE new Colonial Theatre on South Prairie street, in Galesburg, Ill., will be opened about November 1, and when it is completed it will rank among the finest motion picture theatres in Illinois. The building is to be fireproof. It will have a washed air ventilation system. The lobby is to be in marble. In the foyer will be a drinking fountain. There will be toilet rooms for men and women and a retiring room for women. The operating room will be as safe as it possibly can be made. Manager Schroeder plans to show big features exclusively and with a seating capacity of 700 he will be able to handle large crowds.

Lafe Weinberg, who is building a theatre near the new Colonial, expects to have his motion picture play house ready to open about Thanksgiving. His theatre will have a seating capacity of 800, and while it is being particularly built for motion picture shows, it will be equipped with a stage so that vaudeville can be introduced if desired.

FLORIDA THEATRE WILL COST \$40,000

WHAT will perhaps be the most perfectly equipped moving picture theatre in the South at the present time will be the new Republic Theatre of Jacksonville, Fla., upon its opening on October 15. The new theatre, which will probably run a feature program of the highest water, occupies the same building vacated by Moulton & Kyle, undertakers, on West Forsyth street. The work of remodeling and fitting has been going on since July 1, and, when finished, will have cost about \$40,000.

The entire furnishings, color scheme of green, ivory and gold high lights and equipment of the house will be of the most modern pattern and absolutely fire proof. Comfort will be assured, as the seats are the best and highest-priced on the market. The seating capacity will be between 700 and 800. The clearance from pit to dome, together with a ventilating system of the best, insures a total lack of stuffiness and a sufficient amount of cool or warm air at all times. The exits have been so arranged that the house may be emptied within the shortest possible time.

The orchestra, which has already been picked with extreme care, will be located

on the stage. The screen, of the most modern make, will be raised six feet above the stage in accordance with the most modern ideas of getting the best effects from the pictures.

The work of construction has been under H. H. MacKirgan, who has spared no pains in the making of the house as perfect and attractive as possible. No hitches in the building have been experienced thus far, and everything bids fair to come out smoothly.

Charles A. Clark, of Jacksonville, is president of the Republic Theatre Company, and the directors are composed of such able business men as Charles A. Clark, Porcher L'Engle, W. D. Barnett, Francis P. L'Engle, H. H. MacKirgan, D. S. McGraw, Myron Howard and J. F. McGraw.

THEATRES HERE AND THERE

It is rumored that Rochester parties have purchased the corner opposite Hotel Despatch, Main and Commercial streets, Pittston, N. Y., where they intend erecting a fireproof picture theatre with possible living apartments on the second floor.

Work has commenced on Cedarhurst's (Long Island City) new theatre on Spruce street. The building is being erected by Charles Hetrick. It is to have two stores in front. The auditorium in the rear of the stores on the ground floor, will accommodate 750 people.

Architect E. J. Borgmeyer has completed working plans for the brick moving picture theatre and store building to be built at Calexico, Cal., for J. G. Scott. It will be a one-story structure, 50 x 150 feet, and will contain two stores and an auditorium to seat 800 people. The cost completed will be about \$30,000.

Plasterers have finished on the interior work of the Mahoney moving picture house on West Third street between Hayes street and Highland avenue, Chester, Pa., and this work will be pushed toward completion, as the new theatre should be ready for occupancy in about one month. Frank Downey, a West End contractor, has the plastering.

Preliminary steps have been taken toward organizing a stock company in Findlay, Ohio, to erect a large movie house. The goal in view of the promoters is, it is understood, a house on Broadway with a seating capacity of a thousand people, with new films, orchestra, etc., at a price of five cents.

A permit for the erection of a motion picture theatre at 1607 Plymouth avenue, Minneapolis, Minn., has been issued by the city building inspector to J. E. Anderson, and H. A. Winperis. The building is to be of frame construction, one-story high. It will cost \$3,500 and will be completed within a few weeks.

The foundation of the New Strand Theatre, Syracuse, N. Y., is nearing completion and the structure is expected to assume form very shortly.

Plans have been filed for a motion picture theatre at Front and Allegheny avenue, Philadelphia, by Peter Kuhn, architect, for J. A. Ridgeway, 2701 North Broad street, that city. The structure will cost about \$15,000.

Work has commenced on a new moving-picture theatre to be erected at 886, 888 and 890 DeKalb avenue, Brooklyn, N. Y., plans for which have been filed by Shampan & Shampan, architects, for M. Eisler, as owner.

The building will have a roof garden with a capacity of 600, making a total capacity of 1,200 people. The structure will occupy a plot of ground 60 x 100 feet.

The general contract for the construction of the new \$110,000 Majestic Theatre to be built in Detroit on Woodward avenue, near Willis, has been awarded to Frank Farrington. He has sublet the terra cotta work to the New York Architectural Terra Cotta Company; the structural steel contract to the Russell Wheel & Foundry Company, and the excavating to M. Ryan & Sons. C. Howard Crane is the supervising architect.

Arthur Connolly has prepared plans for a one-story brick moving picture house to be erected at 200 Market street, Newark, N. J., by John Walsh. It will have a seating capacity of 300. The building will cover a ground area of 45 feet 8 inches x 65 feet, and will be of fireproof construction with tiled floors.

An up-to-date motion picture theatre in Swampscott, Mass., is among the theatrical probabilities of the coming season. A representative of prominent Lynn theatrical interests is now considering the proposition, and although the identity has not yet been made public, it is known that a Lynn architect is working on the plans and an option has been obtained upon a location near the Swampscott depot of the B. & M. R. R.

Geneva, N. Y., is to have another picture theatre, according to negotiations by Charles H. Sweeney, Edward D. O'Riley, of this city, and H. H. Hooven, representing Hooven & Degraff, of Scranton, Pa. It is proposed to build upon the site of the present O'Riley block, in Exchange street, at a cost of \$50,000.

Harry Swartz, brother of Dr. W. W. Swartz, of Auburn, Ind., will open a moving picture theatre in the near future in the building on North Main street, now occupied by H. H. Strole and J. R. McDowell, plumbers and electricians. Mr. Swartz is the owner of this building and will remodel it into an up-to-date picture theatre.

A new two-story theatre is being erected for R. M. Frey at Steelton, Pa., by Bailey & Bassett, architects. The house will measure 40 x 120 feet and will cost about \$12,000.

Irwin & Leighton are asking bids on plans for a three-story theatre building 120 x 161 feet, to be erected in Mahanoy City, Pa., for the Grand Amusement Company.

A permit has been granted to Stacey

Reeves, 2011 Market street, Philadelphia, for the erection of a film theatre at 1529 Chestnut street. The cost will be about \$34,000. Henon & Boyle are the architects.

A. C. Kelley is drawing plans for a moving picture theatre on Fairfield avenue, Bridgeport, Conn. The name of the owner is being withheld at present. The house will seat about 1,000, and will be at the rear of a two-story edifice.

A construction permit has been granted for the erection of a modern film theatre on the site of the old Majestic Theatre in Manila.

Alterations and Improvements

Plans were filed recently by R. A. Kenney with Municipal Superintendent John D. Castles, of Kearny, N. J., for the changing of the old Presbyterian chapel in Kearny avenue, Arlington, into a motion picture theatre. The alterations will cost \$1,745.

Manager Tom Scott, of the Gajety motion picture theatre at Jacksonville, Ill., is redecorating his play house. Mirrors are being installed on the lobby walls and other improvements are being made. When completed the theatre will be one of the most attractive in the city.

Louis Setnik, proprietor of the Lyric theatre at Uniontown, Pa., is remodeling and enlarging his house. He closed the theatre on Tuesday and expects to rush the improvements so as to be able to reopen this month. The capacity of the house will be increased from 450 to 600, an enlarged mirror screen, 12 by 16, will be installed and two new Simplex machines will also be put in. A number of other improvements are planned. When the theatre is completed it will be one of the most complete photoplay houses in that section.

Jacob Silverman, of the Pastime theatre at Altoona, Pa., is planning some improvements to the theatre in the near future.

The entire interest in the motion picture theater at Elkton, Ky., conducted by Peter Balee and Harry White, has been taken over by Mr. White. He will make several improvements and will install new fixtures to bring the house up to the standard demanded of a first class motion picture theatre.

Permit was granted by Building Inspector W. C. Harper, of Milwaukee, Wis., for the erection of an addition 24 by 120 feet to the Liberty theatre at Vliet and Twenty-seventh streets. The seating capacity will be increased 584. The new addition will be built of concrete blocks, and will cost about \$18,000. Charles Tharinger is the architect. More than \$1,300 worth of electrical work will be installed.

A. Baltimore, of New Castle, Pa., has just finished the remodeling of his theatre and it now fills all the requirements of the State law. The entrances and exits were enlarged and the auditorium will now accommodate its large patronage. Two machines will now be operated instead of one. Mr. Baltimore has kept his shows up to a high standard and has built up a large patronage by having done so.

A permit has been issued to Morris Abrams and Harry Drier to extensively alter the Astor Theatre at 224 West Second street, Plainfield, N. J., and having an entrance on West Front street. The improvements to this building, which was recently leased for a term of years to Joseph Coven, of Paterson, who also has an option for one year within which he may purchase the property, will cost in the vicinity of \$16,000.

Work has been commenced recently on the building of an addition to the Pastime Theatre, Attleboro, Mass. At the screen end of the theatre 20 feet will be added, and when completed there will be a small stage. The balcony will also be enlarged to horseshoe shape, which will afford side balconies.

Messrs. Hiscox & Burnett, proprietors of the Rip Van Winkle theatre at Stamford, N. Y., have secured plans for the enlargement of the theatre in which they have conducted a moving picture show for the past few years. The present seating will take care of about 300, and under the new plans it will be enlarged to accommodate about 600.

The moving picture house on Tenth avenue, Belmar, N. J., has been thoroughly renovated and several improvements made, and is open for the season.

How Exhibitors Advertise

TO MAKE MONEY, GIVE IT AWAY

R. E. GUMM, of Lagrange, Ky., has put into operation an advertising scheme which he found to work to good advantage. He announced a certain night as "pay day." Everyone in the audience was to receive a coin in a small sealed envelope.

These envelopes were to be handed out at the box-office with every ticket sold. He instructed the cashier to arrange the envelopes in a box and give them out as she came to them.

On his first night there was an outlay of 200 pennies, 20 nickels, 10 dimes, 4 quarters, 2 halves, and a dollar. There were 237 coins at 10 cents, the equivalent of \$23.70. Deducting from this \$7, the value of the 237 coins, and there was a balance of \$16.70.

Wednesday night is Mr. Gumm's dull-est performance, and this \$16.70 night was his first "pay day." He is in a very small town, and the receipts of the Grand Theatre are usually from \$8 to \$10.

On the second "pay-day" performance the total receipts were more than \$30, and the amount given away was in the same proportion.

The advertising scheme could be operated with other agricultural communities. The handbill, which Mr. Gumm scattered broadcast throughout the surrounding country, is given for the benefit of exhibitors who see in the plan a chance to draw full houses in their own towns. It follows:

WHEAT SOLD

Bob Gumm, an extensive farmer (?) of Oldham County, has disposed of his crop of wheat, for which he received a

Car Load of Money

Here's the part which will interest you: This entire carload of money will be given away at THE GRAND THEATRE. The first lot of money will be given out

WEDNESDAY NIGHT,
SEPTEMBER 9.

Each person attending will receive a sealed envelope containing MONEY. In most cases several times the admission charged.

This is a proposition where you have all to gain and nothing to lose, as the price of admission will not be increased and you will receive the envelope of money in addition to our usual high-class motion picture program.

It is our intention to distribute this

money during the month of September on every Wednesday night. The reason for this sudden outburst of charity is due to the fact that this is the first carload of money Mr. Gumm has ever owned, and to prove that money is "not tight," as stated by some, on account of the European situation.

REMEMBER!

WEDNESDAY, SEPTEMBER 9, IS THE FIRST
PAY DAY AT THE GRAND.

MAKING PATRIOTISM PAY

ELIZABETH, N. J., is known pretty widely as a "slow" town and it partially deserves its reputation. Among the business interests of the city there is a general lack of initiative, it is said, which is holding the town back from the place which it should attain by reason of its natural advantages and mechanical facilities for advancement.

But Elizabeth is intensely patriotic. It is rich in historical lore and it is a stronghold of such societies as the Sons of the American Revolution, the Daughters of 1812 and similar organizations.

Despite this fact, the lack of initiative pervading the city would have prevented any observance of the Star Spangled Banner Centennial on September 6 if it had not been for the enterprise of a local motion picture house manager.

Incidentally, B. A. Holway, who directs the affairs of Proctor's Broad Street Theatre, raised his house considerably in the estimation of the public, secured several hundred dollars' worth of free advertising and "put one over" his competitors. It happened this way:

Holway knows his town and its people. He knew there was great interest in Elizabeth in Star Spangled Banner Day, and he knew there was to be no public celebration. He decided that his theatre would be a good place to nurse patriotism so he got busy and arranged a patriotic program, put out a lot of special advertising announcing the exercises and awaited results.

On the evening of September 6, he was able to view with satisfaction a house packed to the doors. As each person entered the theatre he or she was given a distinctive little program with a flag border and a picture of Liberty embellishing the first page.

Several pictures of patriotic interest were shown and then the stage lights were turned on and the window of the palace, which forms part of the regular stage setting, was opened revealing Maybelle Fisher, a New York soloist,

dressed in a Liberty costume. Miss Fisher sang "The Flag That Waves at Baltimore," which was written especially for the ceremonies in the Maryland city.

Then a troop of Boy Scouts marched upon the stage and went through an impressive drill, closing with a salute to Old Glory. At the end of the drill the orchestra played "The Star Spangled Banner," Boy Scouts who were scattered through the theatre leading in the singing. The whole audience arose and joined in the chorus, and the demonstration was one of the most impressive ever seen in the city.

The newspapers reviewed the exercises at length on the following day and the celebration aroused widespread comment. The usual admission prices were charged, and as the exercises necessitated very little extra outlay, the results from a financial standpoint were entirely satisfactory.

USING LOCAL COLOR IN LOBBY DECORATIONS

MANAGER M. H. SCHWARTZ, of the New Regent Theatre, Syracuse, N. Y., showed "The Wrath of the Gods" two days recently and on both nights there were from fifty to seventy autos lined up and down the street.

Manager Schwartz decorated his lobby with Japanese flags on the ticket booth corners and Japanese fans unfolded on the booth border. Scores of Japanese lanterns hung gracefully around the entrance arch and with the burning incense it was surely an invitation "to come in."

ISSUING A BOOKLET PATRONS LIKE TO KEEP

THE Broad Street Theatre, Bethlehem, Pa., issues a live program for its patrons, which not only contains a list of the coming attractions but is full of interesting film news for reading during the intervals of the performances.

The text consists of gossip accounts of screen players and synopses of features scheduled for a future appearance at the house. The idea is an excellent one inasmuch as everybody more or less takes a serious interest in everything pertaining to motion pictures these days.

The management of the Broad Street Theatre realizes that people are more apt to take home and save a program of this character; hence, the advertising value of such a booklet.

ADELE FARRINGTON IN NEW BOSWORTH PLAY

Adele Farrington, the eminent comedienne, has forsaken the legitimate stage for the screen. Her first appearance as a photo-play star will be as



ADELE FARRINGTON

Addie Balderson in "The Country Mouse."

This play was written and produced by Hobart Bosworth himself, who also takes the co-lead. The story is a serio-comedy of a country couple transplanted into an atmosphere of state capital politics.

CLEVER DOUBLE EXPOSURE IN "PATH FORBIDDEN"

With Octavia Handworth in "The Path Forbidden," the Excelsior Company has produced a picture that has proven to be a big surprise, and a revelation in double exposure. Miss Handworth playing the dual role of the twin sisters, proved to be an ideal selection for the part, and this fact can be readily realized when you see her actually passing a card, dress and other articles to herself.

This film is the result of six years of constant study on the part of Harry Handworth, the Excelsior Company's chief director.

KLEINE OPENS NEW BOSTON OFFICE

George Kleine has opened a new office in Boston, Mass., to handle his line of attractions throughout New England. The office will be in charge of W. R. Marston, at 597 Washington street.

Mr. Marston will have the entire list of Kleine Attractions, including some recent releases which have not yet been shown in that territory. Mr. Marston is well known in the film business, particularly in New England.

Life Photo Buys Out High Grade Company

Producers of "The Greyhound" and Other Successes Also Enlarge Quarters And Will Redecorate Offices and Projection Room

THE Life Photo Film Corporation has bought out the High Grade Feature Film Company, taking over its lease and all its properties. The offices of the High Grade concern adjoin the present offices of the former concern.

Included in the sale is the projection room which will be redecorated and refitted by the Life Photo concern and devoted to projection for the trade.

Bauman and Company has been engaged to redecorate the new offices, particularly the projection room, which will be lined with velvet, and has every convenience.

In addition, the suite of the Life Photo Film Corporation now gives the

company the entire Forty-second street front of the Candler Building.

The progress made by the Life Photo Film Corporation since its first release, "The Banker's Daughter," which was succeeded by "The Greyhound," "Northern Lights," "Captain Swift" and "The Ordeal," has been so rapid as to necessitate these enlarged quarters.

The present offices of the company will be devoted to private rooms for Bernard Loewenthal, the treasurer; Edward M. Roskam, the president; and Jesse J. Goldberg, the secretary. The additional offices will be devoted to the auditors, booking and display departments.

American Company Lives "Close to Nature"

Members Enjoy the Delights of the Open in Camp at Santa Ynez, California —Tell Stirring Yarns by Firelight

MEMBERS of the Flying A company recently enjoyed an outing at Santa Ynez, Cal., in the neighborhood of the construction works and the new dam. Charlotte Burton was especially interested in the works. She was on duty, and dressed for the part.

Her costume scarcely could have been more picturesque, or more advantageous to her striking brunette beauty. She wore riding breeches, a hunting jacket with a boy's shirt underneath, and a large velvet hat.

At night a huge camp fire was lighted on the sands. Winnifred Greenwood says that never had she enjoyed such romantic evenings. Everybody rolled himself in blankets and "reminisced."

Ed Coxen told many tales of his ad-

ventures on the stage and "on locations" picture-making, that were even more thrilling than the role he plays before the camera. And Miss Greenwood herself, who has a wonderful memory, and a gift for narrative, followed suit.

McELROY MANAGER OF GENERAL FILM IN HARRISBURG

Special to MOTION PICTURE NEWS

Harrisburg, Pa., Oct. 14.

C. F. McElroy, who until recently was special representative of the World Film Corporation in Dallas, Texas, has just become manager of the General Film Company's Harrisburg branch, 322 Chestnut street, succeeding I. A. Farrah, resigned.



CARLYLE BLACKWELL AND EDNA MAYO IN "THE KEY TO YESTERDAY"
(Favorite Players—Alliance Feature)

In and Out of Los Angeles Studios

Special to MOTION PICTURE NEWS

Los Angeles, Oct. 12.

THE U 101 Bison Company is producing a drama of two reels by H. G. Stafford, under the direction of Henry McRae. It is the story of two rival railroads battling for the same territory, with the love of the daughter of one of the presidents of the roads for a young clerk denied by the father, who desires to strengthen his financial condition by the marriage of his daughter to one of the principal stockholders of the road.

One of the big scenes will be that where Indians employed on the construction of the rival road are furnished with liquor and blow up a large section of the track.

A gang of cowboys are secured to stop the riot and fighting, and do so after an exciting battle.

Rex de Roselli is cast for the part of railroad president, Marie Walcamp his daughter, William Clifford the clerk, Sherman Bainbridge an Indian foreman and Lule Warrenton the Indian's wife.

Frank Lloyd is playing the heavy lead and directing the production of "Passing Shadows," a two reel subject, for the Gold Seal Universal brand. William Worthington, as Carter an artist and father of Rita (Anna Little), is induced to join a gang of crooks who need his assistance because of his ability in imitating handwriting.

Herbert Rawlinson as Maybrick, a young clerk, falls in love with Rita, learns of her father's connections with the gang and is instrumental in preventing his arrest when the police raid the meeting place of the crooks. The photoplay script calls for several very thrilling scenes and gives opportunity for quick action, and plenty of it.

The Flunkie Who Didn't "Flunk"

"The Tricky Flunkie" is a split reel comedy made by Jack Blystone for the Joker brand at the Universal studio, in which Ernest Shields as the cafe flunkie succeeds in getting the better of the cafe owners and marrying the daughter after throwing all his opponents over a steep bank into a lake.

The present state political campaign in California has given Clarence Badger, of the U studio, material for a political comedy which was produced last week by the Allen Curtis Joker company. The rival candidates were William Farny and Ralph McCombs, supported by Gale Henry, Louise Frazenda and Sam Kaufmann. The title of the picture is "A Political Mess."

In the making of a two reel comedy, featuring Roscoe Arbuckle and Mabel Normand, the Keystone players secured the services of a very excellent actor in the person of Big Ben, a tame seal that makes its home off the coast of Catalina Islands, where the company was working, and Director Mack Sennett immediately changed the story in order to give the seal a good part. The picture is entitled "The Water Nymphs—Fatty and Mabel," and the negative and first print is now on its way to the New York laboratories of the company.

Announcement is soon to be made by the Mutual company of a special two reel feature comedy, to be released every two weeks by the Keystone company. The first of these has been made and will be released under the title of "Dough and Dynamite."

The first features Charles Chaplin and all the stars of the seven Keystone companies took part in the two reel production.

"The comedy feature is to take the place of the so-called feature picture, but this will be a feature in reality," Managing Director Mack Sennett said at the studio the other morning. "These features are not to be ordinary Keystone comedy—they are to be better than the average. We felt that something was needed so that exhibitors could advertise widely and then have

the good will of their patrons after they came and saw the picture. No, this will not interfere with our regular program of three releases each week."

Plays Opposite Heavy Squaw

This week Roscoe Arbuckle is working opposite Minnie, the 350-pound Sioux squaw, of the tribe of Indians who live at the New York Motion Picture Company studio camp, in a western Indian comedy. More than two hundred Indians are used in some of the scenes, all of which are being made in the canyons and along the shore line beyond Santa Monica.

Chester Conklin, who invented the walrus mustache, and for that work of art is now known as "fish face" about the studio, made "The Love Thief" last week, in which he brought the Keystone police force back into life. It is a one reeler of action in which a roof riot and chase take the place of beautiful scenery.

Sid Chaplin, English comedian, brother of Charlie, who was due to arrive at the Keystone studio last week to play leads, kept the wires between here and Quebec hot asking for night and day letters of consolation. Sid occupied a stateroom next to one in which a man became ill with scarlet fever.

The quarantine officers came aboard, and as Chaplin was the only one who had a room near the man, he was taken



THE WRECK OF THE CAMERA AFTER THE AVALANCHE THAT OVERTOOK THE "TREY O' HEARTS" COMPANY A FEW DAYS AGO.

into quarantine. The comedian is immune from the disease, having experienced it in the days of mumps, whooping cough and measles; so now all he has to do is to wait and prove it to the health authorities. He is now expected to arrive in Los Angeles about November.

California Feature Ships Negatives

The California Feature Film Company, a partnership composed of G. W. Brown, president; Frank Montgomery, producer and general manager, and Rex Downs, secretary, have shipped their first negatives to New York, where they will be released through Sawyer, Inc. The company is making two brands, the "Monty" comedies, being produced by James Davis, and the "Darkfeather Series," featuring Princess Mona Darkfeather (Mrs. Montgomery).

The series will consist of twelve subjects of two reels each, and the first is entitled "The Romance of a Red Princess." This was taken in the canyons north of Glendale and a tribe of several hundred extras as Indians were used. The stock company is composed of Joseph E. Singleton, Raymond Nye, William Ryno, William H. Carroll, J. K. Messick and Anna Messick. The second picture, "The Adventures of an Indian Maiden in the City and at College" was recently filmed. The scenarios are by D. F. Whitcomb.

The Monty comedy company has made two pictures, "Touching Dad" and "A Horse of Another Color," in which the principals are Rex Downs, Miss Billie Rhodes and Harry Fisher, Jr.

At the Selig Edendale studio, Director E. J. LaSaint last week made "Check Mates," in which two old men used the science of the game to prevent the son of one from being ensnared by an adventuress. The part of the father was taken by Guy Oliver; his friend was Jack McDonald; Al Blake played the part of the son, and Stella Razeto the woman.

"Doc" Cook in Polar Feature

Jack Prescott, former husband of Thais MacGrane, and well known comedian of the speaking stage, is now a photoplayer, having joined the forces of the Albert W. Hale Kalem Comedy company at the Santa Monica studio, succeeding John Brennan.

Announcements have been made by the Balboa company, of Long Beach, that Dr. Frederick A. Cook, Arctic explorer, Chautauqua lecturer and reputed discoverer of the North Pole, is to cooperate with the company in the making of a six reel feature picture, "The Explorer." Dr. Cook, it is announced, will play the name role. Frank M. Wiltermoed, scenario editor for the Balboa company, is writing the photoplay story, and will incorporate numerous scenes to substantiate the claim of Cook that he reached the Pole on April 29, 1908.

Locations for many of the scenes have been selected on the San Bernardino Mountains, where there is snow the year

round. Eskimo dogs and sleds, Arctic zone clothing and expedition necessities are being collected and the explorer himself in all probability materially assist the company in securing for the picture the true atmosphere of the Far North. Many of the snapshots taken by Dr.



MAX FIGMAN

Cook will be used in this picture, which constitutes a romance in which the explorer wins a bride by proving his claim of being the first to reach the Pole.

It is the intention to make the picture educational as far as possible, without interfering with the story, and with this end in view the ascent of Mt. McKinley by Cook and scenes of the Belgian South Pole Expedition of 1897 will be shown.

A comedy of all stars, including Henry B. Walthall, Wallace Reid, Robert Harron, Blanch Sweet and Miriam Cooper, was directed by Donald Crisp last week in the production of a two

reel Majestic picture from the story "The Odalisque," by Leroy Scott, appearing in a recent issue of a popular magazine. The story contains a double romance and deals with the struggles of two young girl clerks in a department store, the forced attention given them by managers, and the break in friendship caused so often by promotions.

"What's-His-Name" Coming Soon

The postponed release of the Lasky production of George Barr McCutcheon's picturized book, "What's His Name," will occur on the Paramount program, November 22, when Max Figman, whose work in "The Man on the Box" suggested his further engagement by the Lasky company, will be seen in a role exceptionally to his liking.

Mr. Figman plays the part of the husband of a prominent actress who is "interned" at Tarrytown in a home for which the actress is paying. He is being "kept out of the way" by her, at the suggestion of a Mr. Fairfax, millionaire and man-about-town, who is fascinated by "What's His Name's" wife.

Director General Cecil De Mille considers "What's His Name" the most compelling story Lasky has yet filmed. Its heart interest is direct and the story is one that should strike a responsive chord in all classes.

"Ready Money" Set for November 5

Within the next two weeks the Jesse L. Lasky Feature Play Company will release the third of the Edward Abeles photo-plays with the famous comedian in roles aptly suited to his peculiar comedy abilities, when James Montgomery's highly interesting play, "Ready Money," is seen on the screen Novem-



THE OFFICERS OF THE OZ FILM COMPANY

Left to right: C. H. Rundel, Secretary; L. Frank Baun, President; H. M. Halderman, Treasurer; Louis F. Gottschalk, Vice-President.

ber 5. "Ready Money," although a purely American play, enjoyed success in seven different languages at one time.

While the New York company was playing at Maxine Elliott's Theatre, other companies were playing, simultaneously at Duke of York Theatre, London; Teatro Polytheama, Buenos Aires, and Berlin, Paris, St. Petersburg (Petrograd), Bucharest, Roumania and Vienna enjoyed Montgomery's show, which was one of the few American plays to be translated literally into other tongues without radical changes in locale, plot, and so on.

In addition to Edward Abeles, Theodore Roberts and Bessie Barriscale were cast in prominent roles. Five reels and two hundred and sixty scenes compose the complete production.

Lillian Gish Back to Majestic

Lillian Gish, who has not appeared in Majestic-Mutual releases for the past three months, because all of her time was taken in playing a leading part in the D. W. Griffith feature of nine reels, "The Clansman," was last week featured in a two reel production, "The Tear That Burned," for the Majestic release, produced by John B. O'Brien.

This picture is from the story by John W. Kellente, and was spoken of at the studio as a heart interest drama. Miss Gish takes the character part of Meg, a woman of the streets who reforms and leads a better life because of her love for an old blind woman. Mrs. Josepha Crowell and W. A. Lowrey are assigned important parts in the cast.

Walter Long, heavy lead at the Reliance-Majestic studio who serves as a life saver at Ocean Park beach on Sunday, declares he has found the stingiest man. After rescuing a swimmer from far beyond the breaker line, the man appeared on the beach, thanked Long for saving his life, and then with his be-diamonded hand offered a dime to the life saver with the suggestion. "Here, buy yourself a cigar!"

Long, at the time, was on the way to the "hot-dog" stand for a sandwich and carried a nickel in his hand. "Here, mister, is your change," he called to the departing stranger, who took the nickel and walked away. Long has the dime nailed on the wall of his dressing room as a memento of the occasion.

Lehrman in Speed Case

Henry "Pathé" Lehrmann, producer of the new comedy brand for the Universal program, the L. KO., was recently arrested for exceeding the speed limit with his big Fiat while on the way to the studio. Lehrmann pleaded guilty, and this being the third offense, the judge ordered him to jail. He received a sentence of thirty days. Lehrmann appealed to the higher court and was released on \$500 bond. A burlesque on motorcycle officers may be expected.

"The Ghost of Smiling Jim," a western mining story by Grace Cunard, was filmed last week by Francis Ford. Miss Cunard played the double role of



NELLIE DULUTH INTRODUCES HER HUSBAND TO FAIRFAX
Scene from "What's-His-Name" (Lasky-Paramount Feature)

mother and daughter in this picture which shows the husband and father, a miner, who makes a lucky strike. He is attacked by a claim jumper who throws him over the cliff. The fall causes him to lose his memory which he recovers fifteen years later when hit by a falling tree. He and his daughter then recover the mine, taken by Higby, who in the meantime ejected the mother and daughter for non-payment of rent.

Society Sees How Pictures Are Made

The Marshall Neiland-Ruth Roland Kalem company is making a one reel Chinese picture at the Hollywood studio. The men of the cast found it convenient to use pajamas for the oriental costumes to the embarrassment of a number of Los Angeles society women who called at the studio that afternoon to see how motion pictures are made.

Local Manager Fred Kley, of the Jesse L. Lasky Feature Play Company, has leased a 1,200 acre ranch and secured exclusive use for pictures of 3,000 additional acres adjoining, in the San Fernando Valley, fifteen miles north of the company's studio in Hollywood, where practically all of the company's exterior scenes will be made in the future.

The property known as the Wilson ranch, is ideal for a motion picture farm, and was selected after Directors Cecil de Mille, Oscar Apfel, William C. de Mille, Technical Director Wilford Bucklin and Manager Fred Kley had visited numerous localities.

"It is the most beautiful natural spot about Los Angeles," Mr. Kley said, "and practically every conceivable kind of a scene may be made there. A very pretty river passes through the center of the land and it will be possible for us to make a very pretty artificial lake of considerable size.

"There are hundreds of cliffs, valleys, canyons and other useful scenes, including mines, forests and desert. Give us a few weeks and we will have the finest place to make pictures in the world."

Moonlight Scenes Without Tinting

Hardly before the ink of the lease was dry Manager Kley had a score or more workmen at the ranch building the rancho house, a two-story structure of brick and rocks, on top of which several thrilling scenes for "The Rose of the Rancho," filmed by Director General Cecil de Mille and featuring Bessie Barriscale, were taken. The building walls are 30 feet high and about 60 x 60 feet.

Director General Cecil de Mille and Technical Director Wilford Bucklin, of the Jesse L. Lasky studio, have perfected a way of making moonlight scenes without the aid of tinting, and the first successful films will be shown in the coming Paramount release, "The Rose of the Rancho," featuring Bessie Barriscale.

While the new facilities for photographing scenes of this character were in use, strict orders were issued to keep all except regular members of the companies out of the studio, and the Hollywood police in charge had a strenuous time.

One of the largest, and no doubt the handsomest, set used at the Lasky studio was that made for this scene. It required all of the mammoth stage, and represented the court yard at the rancho house.

The comedy company at the Balboa studio, headed by Ben Deely and Mayme Wayne, and directed by William Wolbert, were busy last week making the sixth of the Ima Simp series, featuring Deely and Wayne, whose work is very well known.

"WHERE THE TRAIL DIVIDES"

(Lasky—Paramount—Five Reels)

REVIEWED BY PETER MILNE

"WHERE the Trail Divides" is an impressive picture. Impressiveness is no new merit in a Lasky production, and to say that it possesses that quality is saying that this particular picture upholds the name that its forerunners have created for the brand. Besides being produced with evident care and enacted by a capable cast, and again possessing a remarkably strong story, a question is asked which has long been debated. Should a white person marry an Indian? The picture seems to answer in the affirmative, although in the course of the story there is ample substance presented to form the basis of an argument.

The story is developed with great skill and care by the director and the principals of the cast, which is headed by Robert Edeson. He renders a fine characterization of "How" Lander, the Indian, who takes a white woman as his wife. In order to give the appearance of an Indian he has darkened his face considerably, and in the picture it seems a trifle too dark in some of the scenes.

J. W. Johnston is a well cast heavy, and Winnifred Kingston plays the part of the girl whom "How" marries. It is regrettable that Theodore Roberts was cast for such a small part as Colonel Lander. James Neil, Constance Adams, Fred Montague, Antrim Short and Mary Jane Higbee complete the cast, the latter two playing the part of the principals when they are children.

The light and shadow effects which have been noticeable in all Lasky pictures are also prominent in this. In "The Virginian" we had the hanging scene in shadows, here when "How" has taken Bess as his wife, we see him fondly take her in his arms, but through the window, with the shade pulled down. No photographic faults can be found.

When a picture presents such an absorbing story, and also puts such a vital question, it will gain an even stronger hold



CRAIG TRIES TO STOP THE MARRIAGE

on its audiences than just a plain drama. After the marriage Bess is seen in perfect contentment with her Indian husband; then comes the realization of her position, when a man calls her a squaw. After she has eloped with a persistent lover, who takes her to the city and later she had had a taste of his mode of life, she realizes again that the Indian is the better man. She returns to him.

Her second husband, learning of her acquired wealth comes after her, and attempts to force her to return, but she is protected by "How," who after a terrific struggle finally knocks him unconscious and does not hesitate to put two bullets in his prostrate form.

It may be seen that the plot presented here differs largely from the general run of picture plots. In the manner produced and acted also, it will not pass without creating a very big impression.

"THE DRIFT"

(Warner's-Marion Leonard—Three Reels)

REVIEWED BY PETER MILNE

QUITE a clever device has been employed in this picture to cause it to be exceptionally entertaining, and more so than a good many society dramas. In making the villain appear to be the hero for the greater part of the story lies the merit. His guilt is even concealed from the spectators for a short time, and from the other characters in the play, but one, until the finale.

This may not be a new arrangement of material in film



THE DECISION

drama, but just the same the interest is greatly heightened because of it. And then again the hero is not so much of a hero after all, unless a man who kills another may be termed such. But his crime is never made known to the rest of the characters in the play, and as he committed it in self defense it does not appear as bad as it might.

Aside from these unconventional motion picture characters, characters that are more human than many seen on the screen, the picture contains a good strong story, entertaining from the start. The action runs along in a smooth and natural manner, and the incidents are well connected, leading up to a well-built climax, which comes as a partial surprise.

Playing the lead in the picture is Marion Leonard. Miss Leonard is a popular star, and will be well received in the role she plays here. She is supported by a cast that is quite well chosen.

The story. A young man robs his firm, lends the money to his friend, who loses it at cards. On hearing this the other man makes good his escape. The other returns home to find a burglar in the house. After a fight with him the house catches fire and the body of the burglar is burned. The other man meets the girl and they are married, after she has given evidence against the innocence of her husband's former companion.

But in the end matters are settled according to justice, the guilty man is discovered, and the other is set free from prison, where he was sent after the trial.

NOVEL DECORATIVE EFFECTS IN COAST THEATRE

Special to MOTION PICTURE NEWS

Los Angeles, Oct. 12.

THE Loring Opera House, at Riverside, Cal., opened as a motion picture theatre October 12, under the management of P. S. Harrison and M. M. Rause, who were formerly connected with the Progressive Motion Picture Company exchange in Los Angeles.

A feature of the house is the stage setting. This was made by the Edwin H. Flagg Company, of Los Angeles, in charge of decorations for all Orpheum Circuit theatres on the West Coast, and has a music conservatory setting, with window effects, and a very attractive garden scene for a background.

The pictures are projected above the orchestra.

"WILDFLOWER"

(Famous Players—Paramount—Four Reels)

REVIEWED BY CLIFFORD H. PANGBURN

THERE is an inherent love of beauty and romance in the most cynical of us. The strength of this feeling in the majority of persons is illustrated by the fact that practically no literary or dramatic compositions have gained real popularity unless these factors were present. Experiments with crime stories, problem dramas and the like have been made, but the heart interest story is always the one that wins out. "Wildflower" represents the finest type of this form of story.

It is simple in plot and situation, and flaws could be picked in its dramatic construction, but the great outstanding fact is that it tugs at the heart strings of the spectators, and makes them completely forget themselves in the charm of the story. In other words, it accomplishes its end perfectly. What more could be asked?



WILDFLOWER CONFIDES IN HER DOLLY

This excellence is gained by a happy combination. First, there is Marguerite Clark, then there is a wealth of beautiful out-of-doors scenes, then there is Marguerite Clark, then a touching story, then Marguerite Clark, then a smoothness of action and a complete absence of useless material, and finally—Marguerite Clark.

The effectiveness of Miss Clark's acting is strengthened by a large amount of clever stage business. The most conspicuous of the properties used in this way is a white rabbit. This docile, and at times, long suffering animal shares all of the varying fortunes of the Wildflower, Letty. Some of the most appealing scenes in the picture are obtained by using this rabbit, as well as sundry smaller kittens and puppies.

In itself, Miss Clark's acting is beyond criticism for the quite simple reason that she accomplishes what she attempts in a way which apparently could not be improved upon. Harold Lockwood, who plays the leading masculine part, handles the role in a forceful manner, although he would probably be more popular if made up as a younger man. James Cooley as the weak brother, and E. L. Davenport as the lawyer, do good work. Jack Pickford as Bud Haskins rather overacts the part of the country boy.

Letty Roberts is a charming and inexperienced daughter of the forests who becomes a friend of Arnold Boyd, a wealthy man who has a camp near her home. He takes his wild younger brother to the camp, and is much disturbed by the flirtation he starts with Letty, especially as he is already married.

He is thunderstruck when he learns that she has eloped with his brother. He starts in pursuit and is lucky enough to overtake them just as they have been married, the ceremony of course being void. Arnold takes her to his home to save her from his brother. Then he falls in love with her himself. After a surprising series of happenings the younger brother realizes his folly, and returns to his wife.

"BUY-A-BALE-OF-COTTON" IN FILMS

Special to MOTION PICTURE NEWS

Atlanta, Ga., Oct. 13.

THE buy-a-bale-of-cotton campaign, which just at present is acknowledged to be about the biggest thing in the South, is to be perpetuated in films, thanks to the enterprise and ingenuity of Harry B. Hearn, manager of Jake Wells' Grand, Atlanta's biggest motion picture theatre.

Already the picture, by Mrs. J. Garnett Starr and Mrs. Edward W. Davidson, is being enacted in front of the cameras of the Al Bartlett Film Company, and the completed film will be shown at the Grand in a few weeks. Lew Dockstader, of minstrel fame, has taken one of the leading roles.

"DOUGH AND DYNAMITE"

(Keystone-Mutual—Two Reels)

REVIEWED BY PETER MILNE

WHEN Charles Chaplin, the inimitable English comedian, appears in the title role of a Keystone comedy, supported by a star, hardly less renowned, Chester Conklin, it is a safe bet that one may settle back in his seat to indulge in continuous laughter, for he will see a slapstick comedy of the highest order.

There are some comedians, who in an attempt to be uproariously funny, are undeniably vulgar, and who demand a good stretch of the imagination to be termed humorous at all.

But no such shortcomings can be charged against Mr. Chaplin and his partner.

Mack Sennett, the director of "Dough and Dynamite," again proves his remarkable ability as producer of this variety of comedy. In the entire two reels, very few scenes appear. There are about five in which the greater part of the action transpires, but these five contain everything that is necessary for the principals to utilize in creating the heartiest laughter.

The circumstance that brings about the uproarious situations that follow one another in rapid succession in this picture is that a number of bakers in a restaurant have gone on strike, and it remains for the two waiters, played by Chaplin and Conklin, to do the baking of the establishment. If their actions were anything but farcical, they would not be conducive to the enjoyment of one's bread and rolls hereafter, but the happy part of it is they are farcical, and of the funniest sort conceivable.

In the finale due to the angry bakers' actions the whole place is blown up by dynamite, Chaplin is buried in dough, and the rest among the ruins of the oven. But from the very outset



JUST BEFORE IT HAPPENED

of the picture until this unexpected denouement, the spectator will be convulsed with laughter.

And if by chance he sees the name of Chaplin outside of any theatre in the future he will most surely enter, for the simple reason that he knows that Chaplin is funny at all times.

"THE MILLION DOLLAR MYSTERY"

(Thanhouser—Seventeenth Episode)

REVIEWED BY PETER MILNE

FRANK FARRINGTON, who has become famous through his clever characterization of Braine, the active leader of the band of conspirators in "The Million Dollar Mystery," is sometimes overlooked, due to the fact that he is not the hero of the story. But even though he be a villain he should not be neglected, and he deserves as much praise as his more favored enemy.

He has shown in many instances his remarkable power of imitation. He can assume the part of beggar, doctor, millionaire—in short, any character he may be called upon to impersonate—with the same ease that he carries off his part as the conspirators' chief.

In this episode, with the aid of a wig and false mustache and a slight alteration of his clothing, he disguises himself as a benevolent old gentleman. His disguise is so perfect that Jim is completely taken in, and it is due to no fault of Braine's that he isn't now a captive of the band. As usual, it is the awkwardness of a minor character that brings all the carefully laid plans of the conspirators to an abrupt ending.

"A Battle of Wits" is the caption of this chapter, but it might be called, and just as appropriately, too, "A Battle of Forces," as the second reel ends in a grand scrimmage between Jim and the butler, on one side, and Braine and some four or five of his confederates, on the other, with the former party finally getting the best of the argument. An excellent suspense-producing effect is introduced in the scene in which Jim sees one of the conspirators ready to black-jack him by the reflection in the bottom of his wine glass.

This is the incident that upsets Braine's plans, and when the butler breaks into the house a moment afterwards the scrimmage commences.

There seems to be a little unreasonable and perhaps mis-



THE CONSPIRATORS ARRANGE THE TRAP

takable air of peevishness on Florence's part when she learns that Jim has left his office. Jim certainly has a right to let up in his strenuous duties once in a while, but Florence seems quite angry when she fails to hear his voice over the telephone.

Outside of this fact the episode is just as good as those that have gone before. The solutions of the questions seem just as far away as ever, the mystifying atmosphere is admirably upheld, and the action is just as thrilling and entertaining as ever.

"THE LURE OF THE YUKON"

(Picture Playhouse—Three Reels)

REVIEWED BY CLIFFORD H. PANGBURN

MEN on snow-shoes, pine clad mountains, sledges drawn by "huskie" dogs and log cabins combine to give this picture a quite realistic touch of Alaskan atmosphere.

All the exterior views show snow on the ground, but

the difficulties of photography thus created have been overcome and some very handsome scenes are the result.

While there is no attempt to introduce any particularly daring feat, there are plenty of thrilling incidents in the story which are accentuated by the good work of the players.

Details have been well arranged with the exception of the treatment of the rolls supposed to hold gold. Although these are declared to contain enough gold to put the two miners "on easy street," they are tossed about like sausages.

Queenie Martell plays the only feminine part, and does

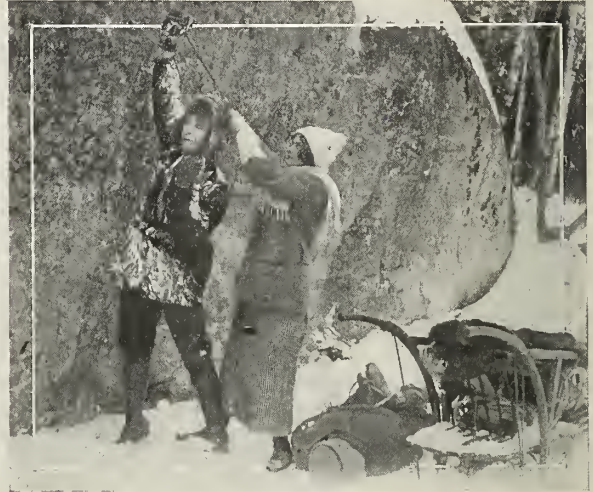

A TIMELY RESCUE

it very well. Her suitor and his brother are portrayed by Walter Wier and Edward Wier, while the villainous gambler is represented by Caribou Bill.

On their way to the coast with their gold dust one of the miners falls in love with a gambler's daughter and tries to elope with her. He is frustrated by her father, and leaves her to her fate. Later, when the gambler robs the brothers and leaves them to starve the girls comes to their rescue. The territorial police go after the crook and his pal and both are killed, while the girl finds happiness with her lover.

"THE PHANTOM VIOLIN"

(Universal Special—Four Reels.)

REVIEWED BY PETER MILNE

THIS picture, directed by Francis Ford and played by Mr. Ford, who is supported by Grace Cunard and a large cast, departs decidedly from the common path of dramas and melodramas.

Perhaps it is more like a work of Edgar Allen Poe's than anything else, as it is gruesome, mystifying from the beginning, ending in a horrible manner.

Grace Cunard, who is also the author of the scenario, has done well with it, and if perchance she left some morbid point out, it is obvious that Mr. Ford has put it in. It is a matter of individual opinion whether the picture will take or not; some will like it, some will not.

The locale is supposed to be Paris. At first we see Ellis, the musician, who plays in a cabaret show, brooding over his violin, the sweet sounds of which entrances a young girl.

The two become very much in love, but after the girl has seen the gay life of Paris she casts him aside, and turns to another. Realistic scenes in a Parisian cabaret, perhaps a little over done, are shown.

Ellis then discovers a cellar under the structure, as it was one of an old castle, and there he makes his retreat, to emerge after several days of voluntary imprisonment, to bring about the death of two other men that the young woman has been toying with.

Later both he and the woman meet a horrible death by falling a great height into the old cellar.

Motion Picture News

HAS THE QUALITY CIRCULATION OF THE TRADE

MOVING PICTURE NEWS EXHIBITORS' TIMES

Published Every Week by

EXHIBITORS' TIMES, Inc.

220 West 42nd Street, New York City.

TELEPHONE BRYANT 7650

Chicago Office, 604 Schiller Building

WILLIAM A. JOHNSTON.....	President
HENRY F. SEWALL.....	Vice-President
E. KENDALL GILLET.....	Secretary
H. ASHTON WYCKOFF.....	Treasurer
WENTWORTH TUCKER.....	Ass't Treasurer

WILLIAM A. JOHNSTON.....	Editor
LESLEY MASON.....	Managing Editor
WILLIAM RESSMAN ANDREWS.....	News Editor
H. ASHTON WYCKOFF.....	Business Manager
R. M. VANDIVERT.....	Advertising Manager
E. J. HUDSON.....	Circulation Manager
C. J. VERHALEN.....	Chicago Manager

This publication is owned and published by Exhibitors' Times, incorporated under the laws of the State of New York. The offices and principal place of business are at 220 West 42nd Street, New York City. The address of the officers is the office of the publication.

Entered as Second-Class matter at the New York Post-Office.

Subscription \$2.00 per year, postpaid in the United States, Mexico, Hawaii, Porto Rico and the Philippine Islands. Canada, \$3.00; Foreign, \$4.00 per year.

ADVERTISING RATES ON APPLICATION.

Copy for next issue must reach us by Tuesday, 5 p. m.

For Releases see Pages 60, 62, 64, 66, 68

For Buyers' Guide see Page 59

Cuts and copy are received subject to the approval of the publishers and advertisements are inserted absolutely without condition expressed or implied as to what appears in the text portion of the paper.

Vol. X October 24, 1914 No. 16

What the League Has Done for Exhibitors

THE new tax scale which the Senate finance committee has accepted in lieu of the flat tax of \$100 on every theatre in the country is a victory for the Motion Picture Exhibitors League of America.

By obtaining the adoption of the graduated schedule the League has proved its usefulness, as a national organization, to every exhibitor whose support it has sought since its foundation.

The protest with which the shortsighted free lances have, time after time, "thrown down" the League—"What good can a national organization do us?"—has been finally and effectually disposed of.

* * *

WITH the recent achievement at Washington fresh in the minds of the exhibitors, President Pearce and his associates can go before the exhibitor body and demand their support, "for value received," and for proven worth.

* * *

THEY can now say to the exhibitor, "You need us. You have always known that we need you. Cir-

cumstances have taught you that you cannot get along without us.

"We have helped you when you needed us, at a time when a government tax scheme was threatening your existence. Haven't we earned the right to your allegiance?"

* * *

THE answer should be an unhesitating "Yes!" in every case.

And yet—to the shame of the exhibitors who will do it be it said—the League heads will almost certainly meet with the discouraging retort in some (perhaps many) cases:

"Yes, you did something for us on the war tax situation. But it wasn't nearly what you ought to have done. It didn't help us much, after all. You'll have to do better than that before we'll come in," and so on, indefinitely.

And the irritating feature of this attitude is that, pig-headed and superlatively ungrateful as the retort will be, it will be, on the surface, true.

* * *

THE new schedule which the Senate committee accepted from Mr. Brylawski is far from being the ideal one for the motion picture exhibitors. Mr. Brylawski would be the first to admit it.

But it was the best substitute that could be devised in the time left for action, before the bill went before the Senate.

And—let this be borne in mind—it was the best substitute that President Pearce, Fulton Brylawski and a few others, with only the name of an organization to back them, could offer to the national legislators with any hope of success.

* * *

THE important fact is, not that more was not accomplished, but that anything at all was accomplished.

Now that the League has done the best it could, in spite of the exasperating indifference of the exhibitors, we shall undoubtedly hear from every one of these indifferant souls that they could have done better, if their own pet schemes had been adopted.

But that is not the point.

The point is that, while hundreds of panic-stricken exhibitors have been wailing and complaining and ranting and mouthing over the situation, a few men have DONE something, something that will benefit all and save the lives of many of those who did not have the power or knowledge to help themselves.

* * *

IF those few men were unable to do all that might have been done, it is the fault of those who have always criticized them and will criticise them now, instead of supporting them, and making it possible for their leaders to have gained a complete victory for them and for the League.

This is not the time for complaint or criticism. It is the time for organization, for cooperation, for shoulder-to-shoulder fighting.

* * *

HELP the national organization to help you. The League can never be worth anything to you, unless you give it your strength and support.

Let this war tax crisis be a lesson, and profit by what you have learned NOW.

LITTLE DORIS FARRINGTON AN EXPERT SWIMMER

Little Doris Farrington, the daughter of Frank Farrington, who plays Braine in the Thanouser serial, "The Million Dollar Mystery," is an expert swimmer.



DORIS FARRINGTON AND HER TROPHIES

Many water contests are held during the summer near New Rochelle, and little Miss Farrington always is among the winners. She is here photographed, enthroned among the many trophies which have been awarded her for swiftness, daring and the "dolphin plunge." Her champion swimming dog, Nep, has been allowed to share his mistress' glory.

NEWMAN COMPANY EXPANDS

The Newman Manufacturing Company, with factories at 717 Sycamore street, Cincinnati, Ohio; 101 Fourth avenue, New York City, and 108 West Lake street, Chicago, Ill., manufacturing a complete line of brass poster frames, rails, easels and brass hardware of every description for theatres, have found it necessary, owing to its increased business, to obtain additional manufacturing space. Accordingly, the company has added another floor to the large plant in Cincinnati, and has installed the latest and most improved machinery.

This firm, which has been in business for more than thirty-two years in the production of brass theatre fixtures of every description, and which is the originator of brass lobby frames, is ever on the alert for new and improved ideas in lobby displays. Copy of their very latest 1914-15 catalog can be had upon request.

ALCO OBTAINS ROLFE'S "RIP VAN WINKLE"

The B. A. Rolfe Photo Plays, Inc., has signed a contract with Thomas Jefferson for a screen version of his father's most popular play, "Rip Van Winkle," to be presented publicly on Monday, November 9, as a part of the Alco Film Corporation Program.

Mr. Jefferson will play the title role in this production, and the pictures will be taken in the exact locality in the Catskill Mountains around which the fable was written.

California Hires Circus Performers for Scene

Company Stages Regular Sawdust-Ring Event and Invites Public to Watch Stunts and Get Filmed for "Cabbage Patch"

WHEN the film version of "Mrs. Wiggs of the Cabbage Patch" is released by the California Motion Picture Corporation, the patrons of film drama will have an opportunity to see how elaborately a first class company of this kind works to produce realistic effects.

The circus scene in the play is the genuine article. No makeshifts would do, no second-rate performance would satisfy the stage manager. He had to depict a circus; so he made a circus. He hired a small army of professionals, former stars of the sawdust ring. He erected a big tent at the company's outdoor studio near San Rafael. He advertised his show free to all who might care to see a circus for nothing, and at the same time, see how a big motion picture reel was filmed.

The day of the novel circus found the tent packed. The crowd of willing "supers" enjoyed the treat, and relished not a little the chance to be photographed for motion pictures.

Just as the audience was the real, joyous article, so the performance was professionally a top-notch. A program was given which was not one whit behind the kind that the small boy risks a spanking to see by crawling under the tent.

La Savillas, a crack tumbling troupe, performed on one stage, while the Benings did bareback riding in an adjoining ring, and, up overhead, the Three Benos did terrifying marvels in an aerial web of trapezes and swings. Komic Kemp, an educated horse, whose comedy act has convulsed hundreds of thousands, romped around the big ring,

and La Belle Carmen, former Barnum and Bailey's feature wire-rope walker and dancer, performed one of her famous acts.

LIFE PHOTO TO SIGN FORBES-ROBERTSON

The Life Photo Film Corporation has secured an option on Jerome K. Jerome's famous play, "The Passing of the Third Floor Back," together with the services of Forbes-Robertson, the famous English actor.

The consummation and closing of the deal only awaits the signature of Forbes-Robertson to the contract, upon his arrival in America.

It will be recalled that Mr. Robertson has played his farewell tour in America, and contrary to the usual farewell tours, insists that he will not again appear on the legitimate stage here. This does not, however, prevent him from appearing on the screen.

COSMOS ANNOUNCES NEXT FEATURE FILM

The Cosmos Feature Film Corporation are now showing the completed photoplay version of the dramatic success, "Lena Rivers," in five parts, featuring Miss Beulah Poynter.

Announcement is also made at this time that the next feature released by this company will be entitled "Hearts and Flowers."

State rights for "Lena Rivers" are selling fast.

The Cosmos productions have met with considerable success.



EDWARD ABELES IN A SCENE FROM "READY MONEY"
(Lasky-Paramount Feature)

"EVEN UNTO DEATH"

(Albuquerque—Warners—Three Reels)

REVIEWED BY CLIFFORD H. PANGBURN

DOT FARLEY may be called the presiding genius of this film, as she wrote the scenario and played the leading feminine part. As the title implies, the story is a tragedy, but it is not a tragedy in the strict sense of the word, because it portrays the triumph of a perfect love.

The scenes of the story are all laid about a fishing village, and are very attractive. Considerable interest is added to one portion by some pictures of live seals swimming near the rocks from which the heroine is making sketches of the animals. There are many other scenes in which the sea plays a most important part, and they are all very well done.

The climax of the story and the highest point of photographic excellence is reached in the fight between Dorthea's fisherman lover and her brother. The former is getting ready to turn in for the night.

He is standing alone in his little cabin, the moonlight streaming in through the window being the only illumination. Suddenly the door opens and his sweetheart's brother enters.

In another moment he seizes a revolver lying on the table and attempts to shoot the fisherman. A furious struggle takes place. The men circle about the room; now they are seen clearly in the beams of moonlight, now they are vague forms in the shadow. The dust from the floor floats up through the moonbeams, swirling about as a piece of furniture is knocked over, or the fighters quicken their movements.

At last, the younger man gains an advantage. The revolver flashes, and the assailant is dead. It is a splendid scene.

Jack Conway plays the part of the humble lover. His acting, as well as that of Miss Farley, is effective and convincing. The love scenes are especially well acted. The minor characters are also well played, particularly those of the old minister and his wife.

The story concerns two brothers who are fishermen at a small seaside town, and a brother and sister of wealth, who live in the same place. By rescuing the wealthy girl when trapped by the tide, one of the fishermen becomes acquainted with her, and they fall in love.

The girl's brother is bitterly opposed to the match, and tries to interfere. He is finally made to believe that their relations are improper by the gossip of an old maid. He attempts to kill the young man, as described above.

His plea of self-defense being of no avail, the hero escapes from jail with the help of friends, and lives on an island for weeks, an overturned boat leading to the belief that he is drowned. His sweetheart is taken ill and pines away with grief. He comes back to her only to have her die in his arms. Taking her up he walks out into the sea.

"THE SQUATTER"

(Eclair-Universal—Three Reels)

REVIEWED BY PETER MILNE

THOSE who are familiar with the films of the Eclair brand need not be told of their excellent photography, as such a merit is a common occurrence in these pictures, and this one takes its place with the many others of the company.

And the art of the photographer has been extended to take in some exceptionally beautiful scenes. One especially pretty is that in which the San Xavier Mission is shown in the distance. In fact, the entire picture is one in which beautiful scenes, shown off prettily by excellent photography, follow one another in rapid succession.

While the picture contains a most absorbing story, one that holds the interest continually, it could be shortened without harming the beauty of it; and in all probability it will be, as the picture has almost three distinct endings in the last reel; and the first of these three should have been made the actual end.

Enacted by the capable Eclair Western stock company, with Bob Frazer and Edna Payne playing the leads, supported

by Nobert Myles, Fred Hearne and Will Shearer, the production deserves great praise in regard to this line.

The dishonest ranch foreman, whose main object is to make all the money he can, and cheat everyone he meets, is finally brought to justice by his employer's nephew, who comes out West under an assumed name.

"THE PURSUIT OF THE PHANTOM"

(Bosworth—Paramount—Five Parts)

REVIEWED BY JULIAN M. SOLOMON, JR.

THE first thing that strikes the spectator, after the clever introduction of the principal characters in this play, is the excellent photography and the beautiful natural setting.



THE ARTIST ATTACKS YOUNG VAN ZANDT

The story opens with Richard Alden (Hobart Bosworth), artist, trudging along the cliffs at Laguna, California, with his dog, Skookum, his bicycle and his painting kit. After finding a spot that suits his purpose he starts to work.

At the village he meets a city girl (Rhea Haines) and their their acquaintanceship ripens into love. They make daily journeys to the beach cliffs, where he works on his picture which grows before the spectator's eyes. Unknown to them they are watched by a little, elfin sprite, a waif of the beach (Helen Wolcott), who, after reading her "Grimm's Fairy Tales," weaves dreams of romance and happiness around the two. She can see nothing but happiness for them.

Soon, however, comes Wyant Van Zandt (Courtney Foote), a young millionaire, on his private yacht. He courts the city girl, thinking how well she would grace his home. Thinking to find happiness along the path of wealth and power, they sail away together. Brokenhearted, the artist feels that the pursuit of happiness has been in vain. He remarks "What I had, I lost."

The play closes with an allegorical scene in the artist's den. A three-part decorated window forms the background. On the left panel is shown in rapid succession by means of trick photography the pursuit of happiness by the rich man, and in successive stages until he holds in his arms not a flesh and blood woman, but a skeleton in black.

On the right side is shown the artist and also in successive stages his rise to happiness from despair until he finds his wife of today by his side. On the centre panel is shown the legend which runs throughout the story. Then the scene fades out and this legend alone is visible as a single point of light in the distance. This rapidly advances towards the spectator until it fairly jumps at him and fills the entire screen.

The story itself was written and directed by Hobart Bosworth, who handles his part with much feeling. Courtney Foote is excellent as the rich man. Helen Wolcott as the waif and as the artist's wife is very capable and very charming. Rhea Haines as the city girl and the wife of the rich man does not do the work of which she is capable. Myrtle Stedman, as Helen Alden, the daughter, needs no comment; her work is uniformly good. E. J. Flynn gives a manly, clean-cut definition as young Van Zandt.

"BOOTLES' BABY"

(Edison—Two Reels)

REVIEWED BY J. BURROUGHS NOELL

A DIRECTOR is treading upon dangerous ground when he puts on the screen a story that is centered around a baby disowned by the father and deserted, however reluctantly, by the mother.

The author has not the same likelihood of being misunderstood, because he can say exactly what he means without fear of misconception; but the producer of motion pictures, having entirely different tools at his command, takes a big chance where the possibility of more than one construction is present.



BOOTLES' HAPPY MOMENT

His task becomes at once twofold or threefold difficult, and he has to depend entirely upon the interpretation of his players for conveying the correct impression, unless he is willing to clog his play with sub-titles, and no director with a fine artistic sense is content to do that.

"Bootles' Baby" is a photoplay in two parts, made from the story by John Strange Winter. The baby's father, Gilchrist, has refused to acknowledge his marriage with the mother, and declines to help the mother to support herself and the child.

She is driven by force of necessity to leave the baby and earn her living, because the fact of the child would be hard to explain, and she could not in that compromising light hold a position in a household as companion, the only sort of work for which she is in any way fitted.

Therefore, she places the baby in its father's room in the barracks, and takes a loving farewell. When Gilchrist finds the child, he knows very well that it is his own daughter, but hard-hearted man that he is, he has not a spark of affection for his offspring, and maliciously puts the baby off on an unmarried fellow officer, a captain that always goes by the name Bootles.

Bootles becomes attached to the child at once, and in spite of gossip takes care of the child most carefully and tenderly. Later, at a house party, the mother and Bootles meet, the mother as companion to the Countess.

They become interested in each other, and finally the captain proposes, but the woman has to hide her real feelings and hold a barrier between them. Gilchrist is present at the same house, and treats the unhappy mother with sneers and derision whenever he has a private opportunity.

But his heartlessness is short-lived, his useless life being cut off by an accident. He confesses that he is the father of the baby. Soon Bootles receives a letter from the mother, asking for the child, and Bootles, after a struggle, resolves that the only manly and honorable course is to give up the child, great as his love has become.

But the happiness of all is complete when he meets the one woman that he least expected to meet. She claims the child, and he claims her, and she is now free to submit.

It is easily apparent that only superior acting could convey the right impression to the audience of this story. Put the

cast which has been chosen performs its far from easy task with supreme confidence in its ability to portray this tender and yet happy story of misplaced and also rejuvenating affection.

Every delineation is characterized by simplicity, truth, and genuine feeling, and the determination to give distinctness to the role. There is everywhere the repose that only finished players can attain; never is there a useless display of emotionalism even in the most intense dramatic moments.

Herbert Prior, as Gilchrist; Robert Conness, as Bootles, and Mabel Trunelle, as the mother, have had no better vehicle to demonstrate the worth of their respective abilities than this latest Edison release.

"THE SPIRIT OF THE POPPY"

(Kinetophone—Six Reels)

REVIEWED BY H. S. FULD

A PSYCHOLOGICAL study of the deterioration of humanity, through the drug habit, which in a well connected story points a strong moral.

After a rather novel introduction of the principal characters, comes a scene depicting a large field of poppies in full bloom, and this in turn dissolves into the opening scene of the story itself.

In the part of the artist's wife, Edith Lockett deserves special mention. Jack Dunn makes an acceptable villain, and, taken altogether, the cast is well chosen. Special attention seems to have been given the interior settings, and the exteriors, especially the views of New York harbor with the Brooklyn bridge in the background, are very clear and distinct.

For a finale the poppy scene is again used, only this time in the foreground are seen the heads of babies and young children in the centers of the flowers. The foreground fades and older children, then young men and women, and finally the wrecks of humanity, caused by indulgence in the evil, appear in gradual sequence.



THE FATAL RESORT TO AN OPIATE

The fading of these scenes into the other is done in such a masterly manner that the audience is hardly conscious of the trick photography.

The first steps in becoming a slave to the habit are shown, together with the different ways of procuring the drug, and the government's efforts to stop smuggling and stamp out the trade are graphically described and shown.

GENESEE FILM INCORPORATES FOR \$15,000

Special to MOTION PICTURE NEWS

Rochester, Oct. 14.

THE Genesee Film Company has filed a certificate of incorporation with County Clerk Hotchkiss. The directors are Charles M. Rowe, 46 Main street, and George L. Deyo and Jesse P. Willard, 62 State street. The company is capitalized with \$15,000.

"THREE WEEKS"

(Reliable Feature Film—Five Reels)

REVIEWED BY PETER MILNE

"THREE WEEKS!" It's here at last, the much-debated novel by Elinor Glyn has now been put on the film, and there won't be much of a chance for Anthony Comstock and his partisans to raise such a hue and cry, after all.

Those who visited the Maxine Elliott Theatre in New York on Thursday, October 8, when the picture received its initial showing, for the avowed purpose of unfavorably criticising it, were undeniably disappointed.

Those who have read the novel, will notice that the picture follows it, almost without variation, except perhaps in one or two places, where certain periods of time have been skipped over lightly. The principals of the cast are exact duplicates of their famed forerunners in the book.

But the somewhat questionable bits of dialogue which were prominent in the novel have been left to the imagination.

As it stands by itself, it is an exceptionally entertaining production, entirely original, and acted and produced splendidly by actors and a director who knew what they were about. The story lends itself to screen adaptation remarkably well, the situations have been well put together, and never for one moment does the picture lose the inspired interest of the spectator that it gained when the first scene appeared on the screen. These merits, coupled with the great publicity that the novel has enjoyed, will cause the picture to have a very big success.

In regard to the story, it is so well known that it need not be told here. It is enough to say that it is absorbing from start to finish. Madeline Traverse gives an excellent characterization of Queen Sonia. She is well suited to the part, and never overdoes a scene. Mahlon Hamilton is equally as good as Paul Verdayne, the young Englishman, who, it develops, is of royal blood. Arthur Donaldson is very good as Dimtiri, the faithful bodyguard of the queen; his fight with the king and Pavlovitch is most realistic.



PAUL AND QUEEN SONIA

George Pierce does well as the slovenly and debauched King Stefan, and his boon companion, Pavlovitch, as played by John Webb Dillion, is an excellent second heavy. Pauline Seymore plays the queen's companion, and Joseph C. Fay appears as the Prime Minister. Claude Cooper is a spy.

The characters of the prologue are H. J. Smith, Baby McGrath, R. J. Barrett, Joseph Moore, T. Curran and Pauline Seymore. Perry N. Vekroff, who adapted the story for the picture, and who was also director of the production, deserves great praise, which he will surely enjoy when the public has once seen the picture.

CLARA KIMBALL YOUNG IN "THE BUTTERFLY"

THE World Film Corporation announces that Clara Kimball Young's second feature is to be based on Henry Kitchell Webster's story of "The Butterfly," which is one of

the most popular current works of fiction and which enjoyed great popularity when it appeared as a serial story in "The Saturday Evening Post." Clara Kimball Young is just finishing the work on "Lola." Captain Leslie Peacocke is writing the scenario of "The Butterfly."

"LENA RIVERS"

(Cosmos—Five Reels)

REVIEWED BY CLIFFORD H. PANGBURN

"LENA RIVERS" is a play which has a rather unusual history. It was written by the woman who has played the principal part all over the United States. But if such a combination is unusual it is a good one. The theatre-going public has liked the play, and long before its appearance it had become fond of its star.

As a result, Miss Poynter's popularity was increased by her



NANCY TALKS OF MEN

appearance in a play which proved to be a favorite. Now the play has been produced for the screen, and is certain to be popular among all who formerly enjoyed it on the stage, as well as among many others who were unable to see it in its original form.

Beulah Poynter by reason of her familiarity with the play, both as the author and the principal for many performances, knew exactly what was necessary in preparing the production.

This has enabled her to retain many of the comedy features which are difficult to transfer from the spoken to the silent drama. It has also resulted in a presentation of the story almost exactly as in the stage version.

The role played by Miss Poynter is a double one. During the first part of the picture she is seen as Helena Nichols, a country girl. Later she appears as Lena Rivers, the daughter of Helena. The two parts naturally resemble each other, but the latter one is the more important. Charlie De Forest, as Joel, a country bumpkin, supplies considerable comedy of a rural type. Caroline Rankin as Nancy Scovendyke gives a most remarkable portrayal of an old but hopeful spinster.

The story opens with the departure to the city of Helena Nichols. She marries Harry Graham, a young southerner, who has adopted the name of Rivers. They are very happy until the young husband is falsely accused of murder and sent to prison. As he is tried under his right name his wife does not know of his trouble, but thinks herself abandoned. Later the husband escapes from prison with another man. His companion is killed by the guards, but Graham is reported as the one dead. Helena dies and leaves her child Lena with her grandmother.

The grandmother goes to live with Helena's brother. Little Lena's cousin makes life miserable for her, especially after learning that Durward Belmont, a man she had marked for her husband, is in love with Lena.

Graham has regained his position in life and has married Belmont's mother. When he meets his stepson's fiancée he knows she is his daughter because of her resemblance to her mother. When he is seen embracing her his motive is of course misunderstood, but everything finally comes out all right.

"THE WAR OF WARS"

(Ramo—Six Reels)

REVIEWED BY CLIFFORD H. PANGBURN

THE existence of war in Europe does not necessarily make a motion picture founded on it timely. In fact, it might most easily be made the reverse. "The War of Wars," however is a triumph of neutrality.

During its course fortune smiles alternately on the contending parties, and the German and French principals are seen as heroes in a regular sequence. As a final victory of non-partisanship the film closes with an impending Franco-German alliance between an officer from the Fatherland and a fair maid of la belle France.

In one sense, the title is a bit misleading, as it suggests scenes of a titanic character. No attempt is actually made to depict any great battles, the action being concerned with a series of sharp skirmishes about the village Longwy. The mass action in the fighting scenes is excellent.

There is a dash and snap, and at times an apparent desperation which is most convincing. The success of first one and then the other side adds an element of suspense which strengthens the interest.

One of the most meritorious features of the picture is the success which has been attained in the matter of local color and general atmosphere. The uniforms worn by both the German and French troops are quite close to the actual service equipment of the armies of those nations, while the interpolation at strategic intervals of scenes of actual war manoeuvres increases the realism to a noticeable extent.

The outdoor scenes have been selected with much care. In the matter of interiors the picture is especially commendable, both as to their arrangement and variety. Much of the action takes place in a large chateau, and the great variety of interior views of it go far to make up for the necessary absence of any outside picture of the edifice. The mere number of the inside scenes gives the impression of a large and pretentious establishment.

The acting is another good feature of "The War of Wars." In some of the battle scenes there is rather an excess of flag waving and standing about in exposed positions on the part of the soldiers, but actors were ever loath to seek cover when facing the fire of the camera man, and it all looks quite patriotic.

Eric, known as "The Babe," who plays the lead for the



BOMBARDING THE VILLAGE

German Empire, is portrayed by Stuart Holmes. Eric runs through nearly the entire gamut of human emotions, but Mr. Holmes seems to be quite at home in most of them.

The glory of France is seen in Yvonne Granpre, whose role is taken by Edith Hallor in a style which leaves little to be desired. The German general is one of the best in the cast, but his name is not divulged. Other players are Hugh Jeffrey, Leo A. Kennedy and Miss Mayo.

The story tells of the invasion of a French village by the Germans. A young officer when drunk wrecks things about a fine chateau and finally attempts the honor of the daughter of the house. Her rebuke brings him to his senses and his brutal passion is transformed into love. He kills a French inn-keeper to save the girl, who tried to shield him.

For this she is taken by the French, and sentenced to be shot. A German shell strikes down the firing squad and saves her. Many other exciting incidents are introduced, but in the end the French girl and the German officer are seen in each others arms. The war seems to be still in an undecided state.

"THE MYSTERIOUS HAND"

(101-Bison-Universal—Three Reels)

REVIEWED BY PETER MILNE

GRACE CUNARD and Francis Ford have a name for creating mystery stories, and this picture, which is mysterious in each and every scene, only goes to confirm



MY LADY RAFFLES CAUGHT

and uphold the opinion already so well established by their appearances in this series of pictures portraying the adventures of "My Lady Raffles."

The entire three reels are replete with mystery, and mystery of the most thrilling and awe-inspiring sort. But the story is not obscure nor difficult to understand, as might easily be the case unless great care were taken in its production. All the sly actions and exciting happenings point to a clearly obvious end, so that one is not left in the dark, trying to unravel a long and meaningless picture.

Supporting Miss Cunard and Mr. Ford, the director and leading man are Duke Worne and Arthur Mumms.

The story deals with the efforts of Kelly, a detective, to apprehend a band of crooks, led by a woman, whom Kelly once knew as a servant girl. At a reception given by a young debutante the crooks are present, bent on stealing all the girl's presents. Kelly is also on hand, suspecting such action on their part, and he manages to catch a glimpse of My Lady Raffles at work, but she escapes from him by a clever ruse, and Kelly is still left without his prey.

There is an exciting raid and a thrilling chase between two automobiles.

CINCINNATI MAY SHOW FILMS WITHOUT LEADERS

Special to MOTION PICTURE NEWS

Cincinnati, Oct. 13.

THE censorship problem has been practically settled for the exhibitors and all are now showing approved films without the state leaders, with the approval of the police.

Some of the exchange men are not satisfied, however, as their films are still being turned back and the number of refusals to pass films has seemed to have increased in several instances.

"THE TICKET-OF-LEAVE MAN"

(Pathe—Three Reels)

REVIEWED BY CLIFFORD H. PANGBURN

FOUNDED on Charles Reade's novel, "Foul Play," this film has an excellent story to tell, and it tells it well. Practically all of the exterior scenes are laid in Australia or on an uninhabited island. By taking these scenes in Bermuda correct as well as attractive effects have been obtained throughout.

The cast is a strong one, including many of the favorites of Eclectic pictures. The heroine, Helen Gerard, is played by Eleanor Woodruff, who blends good acting and charm, even when she has to appear in a rather unfashionable gown made of a gunny sack.

Harold Meltzer as the persecuted hero is equally effective,



HELEN HEARS THE BURGLAR

while Sheldon Lewis, if the phrase is allowed, is an admirable villain. William Riley Hatch appears as Helen's father, a much more agreeable role than many in which he has been seen. M. O. Penn and George Middleton also have important parts.

There are a few points in the story which do not seem very plausible. For example, insurance companies are not in the habit of insuring ten good-sized cases alleged to contain gold, without first making quite certain that metal is present. However, that is something for which the author of the novel is responsible, and it does not detract from the interest.

Allan Bancroft is left in control of his father's business, as the older man wishes to retire. Being pressed for a large loan by a money-lender and not daring to ask his father for it at the time, he forges a note for the amount in his father's name, payable to a friend, Chester Livingston.

By pretending that it is a harmless ruse he gets his friend to indorse the note. It is protested by the father and the son's friend is arrested and tried for forgery. His treacherous friend refuses to clear him, and is taken with brain fever as a result of his fear.

Chester is sent to a penal colony in Australia. After a little over a year of his five-year sentence he is released because of good conduct and for saving the life of the governor-general's daughter by stopping a runaway horse. He is given a ticket-of-leave. Meantime, the false friend has come to Australia and is engaged to Helen, the girl Chester had rescued.

Allan, being again hard pressed for cash, arranged to wreck a steamer having a fake shipment of gold on board. Unknown to him, his fiancée starts to England on the ship.

The plot is discovered by Chester and a sailor, but not until it is too late. However, Chester and Helen reach a desert island, where they live for some time.

Helen learns the true story of her lover's perfidy, and falls in love with Chester. They are rescued by a searching party on her father's yacht. Allan is exposed and Chester's innocence established. The father blesses the happy young people, and—"all's well that ends well."

"THE GREAT GOD FEAR"

(Majestic-Mutual—Two Reels)

REVIEWED BY PETER MILNE

THE two young stars, Robert Harron and Mae Marsh, perform here, and give ample proof that no matter how young they are, they are capable of creating just as much interest and performing just as well as some of the more mature players of the day. Donald Crisp directed the picture, and he also proves that he is just as good a director as he is an actor, which is saying a good deal.

The story is not one which is worked to death and sets forth some original ideas on the part of the scenario writer and the director. These, however, would count for little if the picture were not acted capably. The scenes and photography leave little to be desired and reach the usual standard set by all pictures of this brand.

"The Great God Fear," which gains possession of a suspicious member of a northern lumber camp, is responsible for his mistake in spreading broadcast the report that one of the members has leprosy, when in reality it is only a slight skin disease, and not at all contagious. He comes near breaking up a happy love affair in the bargain, but is prevented by a wise doctor, who calms the fears of all.

"THE LONG WAY"

(Edison—Three Reels)

REVIEWED BY J. BURROUGHS NOELL

WHEN the love affairs of five different persons are closely interlocked, one may expect complications and heart aches before the misunderstandings can be straightened out, the mistakes lived down, and joy and happiness come to those that deserve joy and happiness.

But there is room for but four persons and one of the five must be gotten rid of somehow.

How this unusual state of affairs is brought about and how it is resolved is told in a novel by Mary Imlay Taylor. The Edison Company, with the capable players in its force and the superb settings at its command, has repro-



THE DECISION TO SACRIFICE HERSELF FOR THE OTHER WOMAN.

duced this story in all its fullness of heart interest and novelty of plot.

The story is condensed into the smallest measure of film that will give satisfactory completeness to this entertaining study of modern society life, occupying just three reels.

Strict economy of scenes has thus been made absolutely necessary, and that the result is so eminently successful is due to the skill and the clear vision of the director. Consequently, there are no side scenes that are simply for the purpose of giving atmosphere or unimportant touches of characterization.

The greatest simplicity of detail has been practiced, which has made the responsibility of the players all the greater in making their parts perfectly intelligible in a few strokes.

WITH ANDREW MACK IN "THE RAGGED EARL" (ALCO).



THE EARL BRINGS KATHLEEN AND UNA TO HIS HOME

FOUR OUT OF FIVE THEATRES USE KEYSTONE

No fewer than four out of five Broadway theatres in a distance of six blocks used Keystone-Mutual comedies in one week recently. Beginning with the Broadway Theatre at Broadway and Forty-first street, then including Hammerstein's, the New York, the Palace and the Strand, every house used one of these great mirth provokers. The only house running pictures in all of the theatrical district that did not use Keystone comedies is a theatre devoted to the output of one manufacturer and owned by him.

An attempt is being made to increase the output of the Keystone-Mutual plant, in order to take care of the business that is indicated by this deserved popularity.

WINIFRED KINGSTON POSES FOR NOTED ARTIST

Winifred Kingston, who will play the leading feminine role opposite Dustin Farnum, in the Lasky-Liebler production of "Cameo Kirby," is posing for Coles Phillips, the prominent artist.

The finished product will appear on the front page of one of the big metropolitan magazines. Miss Kingston was requested, through the Lasky company, by the editor of the magazine, who saw her in the "Call of the North," and suggested to Mr. Goldfish that she would make an excellent ornament for an art page.

Mr. Goldfish then arranged with Mr. Phillips and the work is now well under way.

Bosworth Will Screen Van Loan Stories

Bosworth Finds a Los Angeles Lad, Gordon Griffith, Who Is Particularly Fitted for the Chief Role in "Little Sunset"

Special to MOTION PICTURE NEWS

Los Angeles, Oct. 12. HOBART BOSWORTH is to be seen daily about the new Bosworth studio in the guise of "the terrible Swede," Gus Bergstrom, made famous by the stories of Charles Van Loan, while filming "Little Sunset," a four reel comedy drama, the scenario of which is based upon the Van Loan baseball stories.

For this picture Mr. Bosworth has made a find in the person of Gordon Griffith, a Los Angeles lad, who is playing the name role of little Sunset Jones. Besides being a real baseball fan, he is also capable of portraying baseball in such a realistic manner that he has wrecked several big scenes by causing other photoplayers to forget their parts.

This picture will constitute the Novem-

ber offering of the Bosworth company, and "Hypocrites," produced by Phillips Smalley and Lois Webber, is released this month.

The Smalley-Webber company at the Bosworth studio is now filming "False Colors," which will consist of four reels. The scenario is by Lois Webber and portrays the life of a celebrated actor, who because of his profession, was forced to leave his child in the care of supposedly good people.

For this some very special scenes will be made and the Morosco Majestic Theatre in Los Angeles will be artificially lighted and used for a number of big sets. The leads are taken by Mr. Smalley and Miss Webber with a supporting company including Courtenay Foote, Charles Marriott, Adele Farrington, Herbert Standing and others.

English Firm After Rights of "The Ordeal"

Foreign Company Said to Want Life Photo Feature for Exhibition in France and England—Subject a Strong Peace Argument

THE Life Photo Film Corporation's last release, "The Ordeal," is about to be exhibited in New York.

The appointment made between Acting Secretary of State Lansing and Mr. Goldberg, secretary of the Life Photo Film Corporation, for the purpose of having a representative of the government review the picture in Washington, has been postponed.

Several offers have been received by the Life Photo Film Corporation to purchase the rights to this production for the United States and Canada, but these offers have been declined.

Negotiations, however, are in progress for the sale of the rights to this picture for England and France, a large

sum having been offered by a representative of one of the biggest film producing concerns in London.

Mr. Roskam, the president of the company, maintains that it is a strong argument for peace, in view of the fact that it shows the horrors of war.

In the making of the picture the company built its own village and streets, including several buildings, which, in the course of the production, were destroyed by fire and shell.

The picture will not be released through the ordinary channels in New York, but will be shown in one of the large regular theatres, and run as an independent production.



HOBART BOSWORTH, MYRTLE STEDMAN AND THE COMPANY IN "THE PURSUIT OF THE PHANTOM"

(Bosworth—Paramount Feature)

Live News of the Week

The Box Office Attraction Company and the Greater New York Film Rental Company, both owned by Wm. Fox, of New York, have opened an exchange at 3632 Olive street, St. Louis. Ralph Pinkham, former manager for Warner's Features, in the Benoist Building, is general manager, and Lou Bent, for several years connected with the Mutual Corporation Exchange, is assistant manager.

Mr. Pinkham has been in the city for only a few months, but his evident ability and his strong and pleasing personality, have created a very favorable impression in film circles, and Lou Bent, whose middle name is "moving pictures," is one of the old timers in the industry.

The exchange is in a brand new building with a force fully and completely equipped to handle film rental business with promptness and dispatch down to the most minute detail.

The Rudolph Wurlitzer Company has installed a motion picture orchestra in the Isis Theatre, Wellington, Kan. The theatre is owned by C. E. Glaman, who has two other theatres in the State, and who is also vice-president of the Motion Picture Exhibitors' League of Kansas. They have also installed a motion picture orchestra in the Star Theatre, Wichita, Kan., of which C. C. McCollister is the owner.

The Albany "Evening Journal's" scenario contest has closed. There were about one hundred entries, and some of the efforts look most promising.

The William Fox Box Office Attraction Company has just opened offices in Denver, Colo., in the Ideal Building, under the management of F. W. Bandy.

Webb Drum, recently of the Special Feature Department of the General Film Company, has accepted the management of the World Film office at Seattle.

Walter S. Rand, recently manager of the Mutual Film Corporation's office in Salt Lake City, Utah, has just returned from New York, where he received the appointment of special representative for the Mutual Film Company, with authority over the Denver, Salt Lake City, Butte, Spokane, Seattle, Portland and Phoenix offices.

Mr. Rand was manager of the Denver Mutual offices during 1913, and later took charge of the Salt Lake territory.

Bert Angeles, who gained considerable reputation as director of comedies and dramatic features while with the Vitagraph, Imp, Pilot and Historical Film Company is now at liberty.

Mr. Angeles is well known throughout film circles, having attracted a great deal of attention from the time he first appeared in the field.

His work is characterized by an adroitness and skill which have placed



BERT ANGELES.

him in the front ranks of his profession. It is said by those who are familiar with his attainments that he has a remarkable faculty for seeing the possibilities in apparently insignificant incidents in script, and can, by sheer force of imagination and clever direction of the players, build up scenes of gripping power.

Mr. Angeles' present address is the Screen Club, 165 West Forty-seventh street, New York City.

The first production of Bosworth, Inc., supervised by Lois Weber (Mrs. Smalley), entitled "Hypocrites," is now completed and released. It is a very stirring drama, produced with all Miss Weber's artistry and power.

Andy Clark, the ten-year-old Edison comedian, has been a busy little man since the opening of school, relating to his companions his many experiences before the camera during the summer.

George H. Murray has resumed his duties with the Morgan Lithograph Company as New York representative, with offices in the Times Building, after an extended vacation. It was rumored that Mr. Murray contemplated retiring and seeking other connections, but his appearance on the job again has refuted all such rumors.

Carleton King, an Edison character man, is frequently called upon to assume the role of a policeman, and makes a very good one. He often goes into a restaurant to grab a bite between scenes and has several times been mistaken for the real article.

A. H. Thost, manager of the Gem Theatre, Fredericktown, Mo., recently visited St. Louis to buy a new equipment for his theatre, part of which was an iron booth for his projecting machine. Besides being an exhibitor, Mr. Thost is the cashier of a Fredericktown bank.

In a forthcoming American release, George Field proved his ability as a runner, as in one scene he was chased by an angry mob of working men. Field ran across several flat cars, jumped into the motorman's seat and gracefully glided away from his pursuers.

Nolan Gane, of the Thanouser company, is a scenario writer as well as an actor, and judging from his first picture that the Thanouser company made, he is just as good a one. "A Dog's Love" is the title of the picture in which Shep, the Thanouser dog, and Helen Badgely, the kidlet, appear.

The New York Motion Picture Company, has elected Crawford Livingston as a voting trustee, to succeed the late Charles J. Hite.

Sally Crute, the Edison leading lady, recently returned from her summer home at the Endicott Hotel, Sound Beach, Conn. Among other conquests, Miss Crute was awarded a silver cup in a dancing contest held at the hotel.

"Cabiria," the Itala Film Company's masterpiece, has ended its season on Broadway, after playing five months. It played without cessation from May 9, last, until October 10, thus establishing a record for a production of this kind. At the present time, it is being offered in Philadelphia, Boston, Chicago, St. Louis and other large cities.

V. H. Hodupp, who has been doing the booking of the Pathe Dailies in New York City, has been transferred to a road position, traveling from the Syracuse branch of the Eclectic offices.

Arthur A. Lee, formerly with the General Film Company, in Canada, has assumed charge of the Syracuse, N. Y., offices of the Picture Playhouse Company, which located in the Eckel Theatre Building recently.

All of the big feature exchanges in Syracuse, N. Y., report unusually heavy business for this time of the year, and are very optimistic regarding business.

Milton Hirshfeld, of the State Street Theatre, Trenton, N. J., has signed a contract for the exclusive rights to the Paramount Feature Photoplays for that city.

A. J. Norwine, proprietor of the Odeon Theatre, Bonne Terre, Mo., has reopened for the fall and winter season, using Mutual service.

I. Dubinsky, of Bonne Terre, Mo., is planning to build a new and strictly modern theatre to replace the one which was destroyed by fire in September.

A contract was recently signed between Harold Edel, of the Strand Theatre, Buffalo, N. Y., and Leon J. Bamberger, representing the World Film Corporation, whereby the Strand will have first-run in Buffalo of all the Shubert, William A. Brady, Charles E. Blaney and Owen Davis features, now controlled by the above corporation.

The first of this new series to be presented at the Strand will be "The Dollar Mark," with Robert Warwick in a leading role. It is expected that the World Film Corporation will do a larger business in western New York since they took on these productions.

"The Nightingale," the first release of the All-Star Feature Corporation through the Alco program, featuring Ethel Barrymore, has created a big demand from all the new Alco exchanges. The next release of this company, entitled "Shore Acres," is to be released on October 19.

"Shore Acres" and "Michael Strogoff" will be the third and fourth releases of the Alco Film Corporation, respectively. "Shore Acres" is an All-Star production, and the Popular Plays and Players produced "Michael Strogoff," with Jacob P. Adler in the title role.

A private showing of "Salomy Jane," founded on Bret Harte's famous story, with Beatriz Michelena in the lead, and filmed by the California Motion Picture Corporation, was held at the Hotel St. Francis, San Francisco, on October 8.

E. S. McFadden, of New York, has succeeded William G. Kaliska as manager of the Allendale theatre, Buffalo, and has already started a number of "different" things to attract larger audiences. Mr. McFadden intends to issue a weekly house organ, containing stories of his attractions and news of the players. The big electric organ is nearing completion and will add greatly to the musical programs at this popular neighborhood house.

George H. Verbeck, of the Buffalo Feature Film company, at 15 West Swan street, that city, reports a number of bookings on "The Littlest Rebel." This feature opened the new Regent theatre in Syracuse recently. It plays the Strand for the entire week of October 5. Among other features which this company controls are: "Ireland a Nation" and "The Life of Verdi," both of which have been booked at several theatres in Buffalo and western New York.

D. M. O'Brien, the new manager at Warner's Pittsburgh office, has taken charge of the place and brought his assistant with him. He states that the business of the company there will be conducted on a most wide-awake schedule and that the company has a lot of good things in store for the exhibitors, who are invited, when in the neighborhood of the office, to drop in and make themselves at home.

A Peerless self-playing piano has been installed at the motion picture theatre in Harrodsburg, Ky., by Lewis and Sills.

George H. Christoffer, special representative of the World Film Corporation, is at present at the helm of the local exchange of that organization during the absence of its managers. Both William H. Irvine and his assistant, Alex. G. Irvine, are in the South, arranging fall and winter contracts. Mr. Christoffer spoke in terms of praise of the Washington office with very bright outlook for the winter season.

S. J. Baker has been in charge of the Kansas City offices of the Blache features for several weeks, during the absence of R. E. Boland.

Management of the Orpheum Theatre, Tuscarawas street, Canton, Ohio, has been shifted into the hands of W. L. Hill, former manager of the Jefferson Theatre at Ft. Wayne, Ind.

Mr. Hill will act as local manager for O. G. Murray. V. L. Schram, former manager of the Orpheum, resigned to become booking manager for the western circuit of theaters owned by Feiber & Shea, of New York.

Previous to his work in Ft. Wayne, Mr. Hill managed motion picture houses in California. The Orpheum will be his first theater in Ohio. His progressiveness is marked by his two first acts as an Ohio manager which were to apply for membership in the Ohio branch of the National Motion Picture Exhibitors' league and to subscribe for THE MOTION PICTURE NEWS.

The Pastime theatre, Wickliffe, Ky., has just installed a new electric player-piano with eighty pieces of music.



THE BATTLE SCENE FROM "SEATS OF THE MIGHTY"
(Colonial Motion Picture Corporation)

ONE OF RELIANCE'S LATEST



A SCENE FROM "BAD MAN MASON"
(Reliance-Mutual—October 14)

Mayer Silverman, of the Liberty Renting Film company, of Pittsburgh, is angry and threatens to resort to the law to get his due. He states that he has the sole right to the "Last Days of Pompeii" and that pirates are getting ahead of him by renting the film in Pennsylvania.

Wallace Beery, of the Essanay company, who is playing Sweedie in the comedies of that name, recently received a letter regarding his "million dollar" face. The writer dreamed that Mr. Beery was Marc Antony and that she was Cleopatra; but she added, "Lord help Marc Antony with your face."

A scene constructed in the Imp-Universal studio, New York City, will undoubtedly attract unusual attention when released in the two-reel melodrama, "The Three Men Who Knew." It is an Oriental palace, and pillars, draperies and the images of the Heathen Gods were furnished at great expense.

Stuart Paton is the author, and is also assisting Mr. Crane in the direction of the picture. Dorothy Phillips plays the only feminine role.

Those members of the New York Police Department who were not present at the Police Carnival, held at the Brighton Beach Race Track in June, have been able to see their brother officers in action, since a film taken on that occasion was released by the Edison Company on September 1.

F. A. Wall, scenario editor of the American Film Company, and Marc Edmund Jones, another scenario editor of note, returned to the offices of the company recently from a visit to Santa Inez Valley, Cal. They visited this place to witness part of the construction of the Gibraltar Dam, that will create a reservoir which will furnish water to the city of Santa Barbara. They have been writing scenarios about the dam that will give the public an idea of its construction.

The Photo Drama Company's production, "After the Ball," featuring Herbert Kelcey and Effie Shannon, will be handled by A. E. Siegel in the States of Ohio and Michigan. The company name of the new enterprise is the Big Attraction Film Company, and will be located on the fifth floor of the Columbia Building, Cleveland, Ohio.

Another Frontier company has been formed under the direction of Joe Franz, which will produce western dramas. Mr. Franz formerly played heavy leads for the old company.

Helen Dunbar, character woman of the Essanay Company, has displayed remarkable aptitude in bringing up the Japanese baby which she adopted several months ago. The child has grown to be the pet of the studio.

The Rudolph Wurlitzer Company, through the Albany office, has just installed a Wurlitzer motion picture orchestra in the Columbia Theatre, Rensselaer, N. Y., which John J. Sullivan owns.

John Jones, well known along the west coast as a character actor, has joined the Frontier Company at Santa Paula, Cal. In addition to his acting he will have charge of the stage mechanics.

The World Film Corporation, distributors under the management of Arthur S. Hyman, for the Shubert and Brady productions, has established quite a record since the recent opening of an office in Atlanta, Ga.

During the past fourteen days contracts have been signed for business amounting to \$56,838.

A RECENT UNIVERSAL



J. WARREN KERRIGAN IN "HIS FATHER'S SON"
(Victor, Two-Reels, Oct. 12)

Leo Levison, of the World Film Corporation's office in Pittsburgh, has been planning to come to New York for some time to go over business with General Manager Selznick. Every time Mr. Levison is ready to come to New York, he finds some Pittsburgh exhibitor on hand ready to sign a year's contract for his pictures and the trip is postponed. This has happened many times in the last fortnight, but Mr. Levison hasn't given up hope of reaching New York yet.

For the direction of Henry Bernstein's picture, "The Thief," the Box Office company has secured the services of Edgar Lewis, producer of "The Littlest Rebel," "Northern Lights" and "Captain Swift."

Hal August, who was with the Universal west coast studios for two years, is now under contract with the Eaco Films. Mr. August gained a reputation when with the Universal as a clever interpreter of light comedy parts.

As a novelty, the parents and other members of the family of Edwin August, of the Eaco Films, have appeared in the leading parts of a special picture taken under the direction of Mr. August. It is the intention of the elder August to preserve the reel and hand it down to his children.

Earl L. Thurstensen, a well known musician of Louisville, Ky., has succeeded Frank Wilson as organist of the Walnut theatre in that city. He was formerly with the Wurlitzer company.

Adele Lane, playing under the Selig brand, was recently severely injured in the taking of a picture. A scene called for her struggling with a bear, who suddenly lost his temper and clawed Miss Lane on both arms. The injuries sustained caused her great pain. The heartiest sympathy is felt for her.



ROBERT LEONARD AND ELLA HALL IN
"FOR THE SECRET SERVICE"
(Rex—Two Reels)

INTERESTING FILM REVIEWS

PRODUCTIONS FROM ALL PROGRAMS

GENERAL FILM PROGRAM

"The Rose and the Thorns." (Vitagraph. Two reels. Sat., Oct. 10.)—A drama intended to point out the fact that a flirt brings herself misery. In this case the flirt is saved from herself when it seems almost too late, and is seen as a happy married woman. In the cast are Darwin Karr, Naomi Childers, Harry Kendall and Frank Currier.

"His Mother's Home." (Biograph. Sat., Oct. 10.)—A drama of a type which is too familiar to be of great interest, but would please some audiences.

"On the Battle Line." (Kleine-Cines. Two reels. Tues., Oct. 13.)—A story in which a man is forced to struggle between his promise to his mother—never to enter a duel—and of defending his own honor. The love for his dead mother proves the stronger. He is ostracised from society but on his deathbed he sees his adopted daughter in the arms of a man who formerly denounced him. This is a highly entertaining number; the battle scene will arouse suspense. The scenes and photography are excellent.

"In Old Virginia." (Lubin. Two reels. Thurs., Oct. 8.)—A highly melodramatic story of the Civil War. A young soldier plays the coward and shams death in his first battle. He joins another company and courts death but lives through the war. He learns that another man is about to marry the girl he loves and that the family homestead is about to be taken by a crooked money lender. He kills the crook and is fatally injured. An old servant buries him and the family never knows of his act. John E. Ince plays the lead.

"The Green Eyed Monster." (Lubin. Fri., Oct. 9.)—A rude sailor is jealous of what he believes to be the infatuation of his sweetheart for a man of wealth. He tries to kill the man, and thinks he has succeeded. His intended victim helps in the reconciliation. In the cast are Velma Whitman, George Stanley, L. C. Shumway and Paul Parr Smith.

"When the Ham Turned." (Lubin. Sat., Oct. 10.)—A "ham actor" is chased out of town and abused by the chief of the village police. He turns the tables and is made chief himself. A rather amusing comedy. Raymond McKee plays the part of the actor.

"The Girl at the Lock." (Lubin. Two reels. Wed., Oct. 7.)—A tragedy involving an artist and a young girl who fell in love with him while posing for a picture. The shock of his marriage to his fiancée kills her. In the cast are Louise Huff, Gilbert Ely, Mildred Gregory, Louis Mortelli and Edgar Jones.

"The Other Man." (Essanay. Two reels. Fri., Oct. 16.)—A story of scheming and a sacrificed daughter for the sake of wealth. However, things cannot right themselves, they become so tangled, and the wronged husband goes back to the trees and nature while the wife is tied to her new home by the arrival of a baby. A strong story with good situations, written by Maibelle Heikes Justice.

"The Hand of Iron." (Edison. Sat., Oct. 31.)—A cruel army officer succeeds in making the colonel's daughter dislike a decent officer who is his rival. Both are sent with a detachment of men to the scene of a riot. The colonel gives positive orders against bloodshed. The worthless officer loses his head and orders the troops to fire, but is stopped in time by the other one. Eventually the better man wins the girl.

"For Love of Him." (Selig. Tues., Sept. 22.)—An actress jealous of a rival in love and in her profession puts acid in her face cream to spoil the other woman's beauty. The plot is frustrated by accident, and the repentant actress gives up thoughts of vengeance. In the cast are Adele Lane, William Stowell and Edith Johnson.

"The New Partner." (Edison. Tues., Nov. 3.)—Gertrude McCoy and Robert Brower do some very good work in this picture. A girl inherits a share in a factory. She hears of the bad conditions which exist in it, and learns of their truth by going to the place disguised as an employee. Her partner rescues her when a fire breaks out. They decide to change their policy and operate the factory with some regard for the workers.

"Buster Brown Picks Out the Costumes." (Edison. Wed., Nov. 4.)—A split reel comedy which ought to please the children. Buster selects rather odd costumes for two maids who are going to a masquerade dance. The minister and others are slightly shocked. Norris Millington is seen as Buster.

"She Landed a Big One." (Essanay. Mon., Oct. 19.)—Another Sweedie picture featuring Wallace Beery. Her beau attempts suicide. He and a friend return and relate how the friend saved him. Sweedie goes fishing. She cannot pull in her catch. The police department is called out to give aid. A three-foot fish is finally pulled to shore.

"Mother o' Dreams." (Essanay. Tues., Oct. 20.)—A good picture with a lot of human interest in it. Played by a strong cast, including Richard C. Traverse, Gerda Holmes, Bryant Washburn and Richard Traverse. This is a strong one-reeler that will be enjoyed by everyone. A young orphan grows up to love her teacher, who unknowingly restores her to her mother. The theme is simple, the situations are good and the acting splendid.

"The Long Range Lover and the Lollapalooze." (Essanay. Wed., Oct. 21.)—Another George Ade comedy of the funny kind. A young lawyer sees the girl of his dreams. He meets her time after time, but does not become acquainted for several years. When he does she merely utters a few sentences. In her own words, "it's fierce!" So the long-range lover's dream is shattered.

"Regan's Daughter." (Vitagraph. Two reels. Tues., Sept. 29.)—A crooked politician and bad man has his daughter brought up in ignorance of his character. A fine young detective becomes his enemy, and when he goes too far is sent on his trail. He meets and falls in love with the daughter. The crook is shot, but blesses the young couple and dies with his daughter ignorant of his crime.

"Jinks and the Barber." (Lubin. Tues., Sept. 29.)—This is on the same reel with "Jealous James." A man agrees to pay the bill for another's turn at a barber shop. The other man takes every treatment in the place. There are other complications.

"The Blue Flame." (Selig. Two reels. Mon., Oct. 19.)—A very good detective drama that has the proper proportion of mystery and trickery to make it worth while. The photography features Stella Razeto and Guy Oliver, through the scheming of Collins, Nell Wade, who is forced to operate with the gang, is installed in the Garvey household. She detests her part of the scheme, but nevertheless is compelled to play her part. The detective sees her worthy points and protects her when the "crime syndicate" is arrested.

"Jimmy Hayes and Muriel." (Selig. Tues., Oct. 20.)—A western drama with a good story. Jimmy Hayes, who is supposed to have deserted under fire, really proves a hero. It is not, however, found out until a year after, when his bleaching bones are found in the shrubbery where he made his last stand. It is recognized as his skeleton because of a pet horned toad, named Muriel, which is still faithful to him.

"The Rajah's Vacation." (Selig. Wed., Oct. 21.)—This is a one-reeler written by Harold McGrath around one of the elephants inhabiting the Selig Zoo. It is a good comedy with plenty of funny situations which are gotten into by a couple of reporters, who attach the elephant of a circus when they cannot col-

lect money coming to them. Rajah, however, proves a big expense and does much damage.

"A Tonsorial Leopard Tamer." (Selig. Fri., Oct. 23.)—Several leopards come into play in this production. A colored barber thinks he will have an advantage over his porter friend if he could only have a uniform with more brass buttons. The animal trainer's uniform at the circus strikes him as just right. He steals it. The leopards follow him because of the catnip in the pocket. In the end, the lady fair considers him a hero because he was too frightened to run.

"The Tragedy That Lived." (Selig. Sat., Oct. 24.)—John and Mary are lovers. Mary is fickle. A duel is to be fought by the rivals. Mary falls asleep and dreams that her ancestors come to life and tell her a similar tale of how a duel was fought because of the grandmother. Mary awakens and rushes to the scene to find that her lover has been beaten.

"Kill or Cure." (Vitagraph. Wed., Oct. 7.)—A comedy which promises to be funny at the start, but which descends to ridicule of crippled persons, and is therefore not to be recommended. William Shea and Kate Price head the cast.

"Their Little Drudge." (Biograph. Thurs., Oct. 8.)—A melodramatic story concerning an artist and a girl who was imposed upon. Holds the interest fairly well.

"Jealous James." (Lubin. Tues., Sept. 29.)—On the same reel with "Jinks and the Barber." A foolishly jealous man gets into trouble because of his suspicions. A prize fighter finally teaches him that jealousy is more than silly.

"The Derelicts." (Biograph. Tues., Sept. 29.)—A girl is confronted with the apparent choice between death and dishonor, but is saved by a sea captain. Later in a far distant land her old persecutor attempts to make trouble for her, but justice takes its course and the man meets punishment. It is a good melodrama.

"They Were College Boys." (Biograph. Fri., Oct. 9.)—On the same reel with "The Man Hunters." The picture is rather hard on college students, but in this it is like most films which attempt to deal with the subject.

"The Man Hunters." (Biograph. Fri., Oct. 9.)—On the same reel with "They Were College Boys."

"Josie's Legacy." (Vitagraph. Fri., Oct. 9.)—A maid at a country hotel receives a telegram that an aunt has died and left her everything. She is at once sought by suitors, but they quickly disappear when it develops that "everything" consists of two young children. Billy Quirk and Josie Sadler are featured. A rather good comedy.

UNIVERSAL PROGRAM

"Rice Industry in the U. S." (Victor. Mon., Oct. 19.)—An instructive reel showing the planting, flooding, reaping, threshing and polishing of rice. It is obvious the film was exposed on a dark day.

"The Violinist." (Eclair. Two reels. Wed., Oct. 21.)—This is a well played offering with Carol Holloway and Will Shearer leading the cast. The young girl marries a violinist much against her father's will. When the husband visits Italy to perfect his art, the father intercepts all letters. With the birth of a child the girl dies; years later the violinist and his daughter are united. Altogether a very pleasant picture.

"Vivian's Transformation." (Crystal. Tues., Oct. 20.)—Vivian dolls up in the madame's clothes for a visit to the beach with her beau. The happenings at the beach are funny but seem to neglect the main line of the story.

"The Witch Girl." (Victor. Two reels. Fri., Oct. 30.)—The first of the Mary Fuller pictures directed by Walter Edwin. Charles Ogle plays the male lead. The story is unconventional and highly entertaining. The wild girl of the mountains is lured to the home of a rich and unscrupulous man. She breaks away, but her actions have taught the man to reform and he comes to her again to seek her hand. The scenes are very beautiful, but the photography could be better.

"Heinie's Outing." (Sterling. Thurs., Oct. 25.)—A lot of rough and tumble work is introduced in this farce without creating the desired effect. It is humorous in parts. Max Asher plays the lead.

"The Quarrel." (Eclair. Sun., Oct. 18.)—A strong drama. Perhaps the idea is slightly conventional, but it is developed well by Mildred Bright and Stanley Walpole, who pay the husband and wife. The wife, in desperation over her husband's drinking habit, determines to leave him and her child, but at the town dance hall she sees another baby which causes her to relent and return home.

"Virtue—Its Own Reward." (Rex. Two reels. Sun., Oct. 11.)—Rather a pathetic story, in which Pauline Busch and Lon Chaney play the leads. To protect her sister from the evil influence of her employer, the older sister allows her own reputation to be suspected. And then her sister disowns her.

"Dolly's Deliverance." (Frontier. Sun., Oct. 11.)—The greaser pursues the man who protected a girl from him until he takes refuge in a dry well. He cuts the rope, but loses his balance and falls with him to the bottom, where he is overpowered and made captive. Fred Church, Dolly Larkin and Joe Franz play the leads in this drama, which, although a little inconsistent, is good, as a whole.

"Off Again, On Again, Finnigan." (Joker. Wed., Oct. 14.)—Taken under Jack Blystone's direction, this picture shows some excellent trick photography which will create much merriment. Ernest Shields plays, the hobo who gives the cop (Eddie Boland) a merry chase, while that gentleman is in his dreams.

"The Funny Mr. Dingle." (Victor. Fri., Oct. 16.)—Mr. Dingle takes his daughter for a sail and capsizes, and then her choice comes to the rescue. A number of laughs in this. C. J. Williams is the director.

"The Padrone's Ward." (Powers. Two reels. Fri., Oct. 16.)—A good, lively story, in which a Black Hand gang is at length brought to hay. The daughter of the leader who helped bring about their capture marries a rich man. Quite old, but acted in a commendable manner by Edna Maison, Bert Hadley and Lloyd Ingraham, the director, who gives a fine characterization of the gang leader.

"The Way of Life." (Nestor. Fri., Oct. 16.)—Eddie Lyons and Victoria Forde appear in a drama here instead of the usual comedy. It is full of action, and all will enjoy it, although it ends sadly. A crook tries to reform, but he is suspected, and shot by the police; his sweetheart is arrested as an accomplice.

"His Father's Son." (Victor. Two reels. Mon., Oct. 12.)—Absorbing drama. Jack Kerrigan appears in a dual role as father and son. Vera Sisson plays opposite. The wife, who has been deserted by her husband, tells her story to her son. He, becoming rich, finds his father and breaks him through the market. A reconciliation follows.

"Country Innocence." (Imp. Two reels. Mon., Oct. 19.)—A little too religiously put to convey the right idea. Only death interrupts the tragedy of misplaced love and its results, from descending on the second generation as it did on the first. Edmund Mortimer, Alexander Gaden and Dorothy Phillips are well cast.

"Some Collectors." (Crystal. Split reel. Tues., Oct. 13.)—On the same reel with "Oh! You Gypsy Girl." Old idea. Nobody is able to collect a sum of money from a broken lawyer. He lands in jail in the finale. Not many humorous moments.

"Oh! You Gypsy Girl." (Crystal. Split reel. Tues., Oct. 13.)—On the same reel with "Some Collectors." Two lovers change garbs with two gypsies and are pursued as horse thieves. Fair comedy.

"Small Pox on the Circle U." (Eclair. Sun., Oct. 25.)—Excellent comedy, with Will Sheerer and Mildred Bright leading the cast.

The Eastern lady is sought after by all the cowboys. The foreman even paints the Chinese cook with pox marks, and quarantines the camp, but an old lover appears and wins her.

"Suspended Sentence." (Powers. Fri., Oct. 23.)—Quite an unusual story, with Edna Maison and Joseph King in the leading parts, supported by the Universal Juvenile Company. The mother, after chastising her little boy, dreams of being brought before a child tribunal and sent to bed without supper. When she awakes she avows never to be severe to her child again.

"Cupid Pulls a Tooth." (Nestor. Fri., Oct. 23.)—Father won't consent to daughter's choice, until that young man gets him in his dentist's chair and threatens to pull out all his teeth. Eddie Lyons, Victoria Forde and Harry Rattenberry play the leads in this amusing picture.

"The Little Blonde Lady." (Rex. Sun., Oct. 25.)—Robert Leonard and Ella Hall appear at their best in this picture, supported by Olive Golden. The young debutante ignores her suitor when she learns that he has become penniless, but her little sister doesn't, and when he regains his riches, he prefers the faithful one. This is an excellent comedy drama.

"Olaf Erickson, Boss." (Rex. Two reels. Thurs., Oct. 22.)—Bob Leonard and Ella Hall, assisted by Harry Carter and Alan Forrest. Realistic and beautiful lumber camp scenes. Rapid and exciting action. The foreman of the lumber camp is a bully, feared by all his underlings, but a woman tames him and they marry. A strong story, backed by fine photography.

"Across the Court." (Joker. Sat., Oct. 17.)—Max Asher, Louise Fazenda, Gale Henry and William Franey are the funmakers in this uproarious comedy. The old bachelor flirts across the court with an old maid, but after proposing, discovers a girl much more to his liking, and proceeds to get married. A lot of trouble and a lot of laughs ensue.

"The Countess Count." (Joker. Wed., Oct. 21.)—The title was changed from "Count Noahcount." The friend of the suitor unfavored by father dresses as the girl and is then married to the count, while the daughter elopes with her choice. Great fun furnished by this comedy in which Ernest Shields, Phillip Dunbar and Betty Shade appear.

"When Their Wives Joined the Regiment." (Joker. Sat., Oct. 24.)—The two hrow-beaten husbands are both captains in the regiment, and when their wives, attempting to be more manly, join the same company, they effect a great cure by putting them in the awkward squad and giving them no rest. This comedy, played by William Franey, Sam Kaufman, Louise Fazenda and Gale Henry, is replete with laughs.

"Universal Boy in the Gates of Liberty." (Imp. Thurs., Oct. 22.)—Very entertaining. Matty saves two immigrants from the clutches of spies from their old country. A well constructed picture.

MUTUAL PROGRAM

"Out of the Air." (Majestic. Two reels. Sun., Oct. 4.)—An exciting series of events leads up to a very startling climax effected by a man leaping from an aeroplane to the top of a freight train, and stopping it in time to save the life of a girl whose foot is caught in the track. The crowning event is perhaps a little too weak, but it is a thriller, nevertheless. An excellent story is presented in this picture, well produced and acted commendably.

"The End of the Galley." (Broncho-Mutual. Two parts. Wed., Oct. 14.)—Replete with strong situations and stirring action, this picture will arouse spontaneous appreciation wherever shown. It is not an altogether new theme nor is the story outstanding for novelty and freshness of conception, but it is presented with fine artistry, in all three branches of the motion picture—acting, settings and photography. Thus the manner in which the presentation is made more than makes up for the lack of originality in the plot, and after all is said and done, the finished manner in which a picture is made is of prime importance.

"The Word of His People." (Kay-Bee-Mutual. Fri., Oct. 16.)—The lieutenant is the last of his race, and his father on his

death-bed utters as he is dying the request that he marry his ward, but at the same time urges him to remember the heritage of his name. The girl agrees to marry the son to comply with the father's wishes, but she loves another. The son learns this and is honorable enough to release her from the engagement. Later the fort is attacked by Sioux Indians; the girl and the two men escape, and the lieutenant gives up his life that she may reach safety. This filmsy recountal of the story doesn't give a fair idea of the strength of the drama, the many dramatic moments and the fine suspense which precedes the sacrifice of the lieutenant.

"Jimmy." (Domino-Mutual. Two parts. Thurs., Oct. 15.)—The quality which is called human interest is an elusive thing and is extremely hard to define in clear terms. But when it is present in a picture everyone instinctively feels it. The loyalty of a little boy for his crippled sister is so beautiful that even the most callous hearted will be touched. His steadfast devotion in keeping her place in the surgeon's office, his persistent pleas for an operation, and his final joy when the operation proves successful are tender and pathetic.

"The Sheriff's Master." (Reliance. Fri., Oct. 2.)—One of Arthur Mackley's Western comedies. A rapid suffragette attempts to introduce her teachings in a Western town, but they don't go very well, and she is forced to take her leave. There are a few laughs in this, but unity is lacking.

"Where the Mountains Meet." (Reliance. Wed., Sept. 30.)—Gardner Hunting has written a fine story here, nothing extra, but the interest is always held, as the climax is well concealed. How a Westerner befriended a consumptive and his daughter is the theme. Rapid action.

"The Million Dollar Bride." (Komic. Sun., Oct. 4.)—Something funny and at the same time original. Tod Browning, Fay Tincher, Ed Dillon and Max Davidson are in the cast. The penniless count attempts to marry a woman who he thinks is an heiress. He is frustrated and cast in jail.

"Nieda." (Beauty. Tues., Oct. 6.)—This is such a tragic offering that one is depressed when its conclusion arrives. The lover of the wild mountain girl meets his death from a fall. In a vision she sees him, walks toward him, and she also falls to her death. Beautiful mountain scenes, Margarita Fischer, Harry Pollard and Joseph Harris are the only persons that appear.

"Our Mutual Girl, No. 38." (Reliance. Mon., Oct. 5.)—In this chapter Margaret has a number of trying experiences all due to the possession of Baby Lily's priceless pin. In the opening scenes Aunt Abbie inspects the latest styles for elderly women, with Margaret.

"The Ingrate." (American. Wed., Sept. 30.)—A drunken brute causes his family much misery, but finally meets a timely death, not, however, until he has caused the death of his little grandchild.

"Hello Mabel." (Keystone. Thurs., Oct. 8.)—This is quite an incoherent comedy, but will produce laughs in places. Mabel Normand as a telephone girl gets herself, her lover, and a wedded couple into all manner of mixups by her telephonic personality.

"Their Ups and Downs." (Keystone. Mon., Oct. 5.)—This is a real sidesplitter with Roscoe Arbuckle in the leading role. Midway in the picture his sweetheart who is about one tenth his size, is carried up in the air by a bunch of balloons. By an excellent double exposure she may be seen floating over a large city.

"Daphnia." (American. Two reels. Mon., Oct. 5.)—This is a picture showing how a counterfeiter's daughter, who had suffered because of a revenue officer, finally seizes her chance for revenge when the officer's son is discovered passing bad money. A highly entertaining offering, in which excellent double exposure work appears in a number of places. Beautiful mountain scenes and fine photography. Winnifred Greenwood is seen at her best, supported by George Field and Ed. Coxon.

"The Cripple." (Thanouser. Two reels. Tues., Oct. 6.)—When her lover is a cripple, the girl practically ignores him; when he has regained the use of both his legs she gladly accepts him. Thus drama is put in a very nice way, and the pitiable actions of the girl will not be condemned. The story is well developed, and is interesting in its entirety.

"The Anglers." (Keystone. Mon., Oct. 12.)—The results that are bound to occur when two furious suitors clash are portrayed here, but contain a little too much rough work to be really humorous. There are laughs in parts, especially when Charles Murray appears.

"The High Spots on Broadway." (Keystone. Thurs., Oct. 15.)—This picture is as risqué as possible, but just misses the vulgar mark. The Rube and his wife arrive in a city hotel and get mixed up with a young married couple. A lot of slapstick work appears.

"Down by the Sea." (American. Wed., Oct. 14.)—A story of the sacrifice of a young man who realizes that another has won the love of the girl he is to marry. Winnifred Greenwood and Ed Coxen play the leads. While the action lags in parts it nevertheless is an interesting photo play with good acting and good sharp photography.

"The Diamond of Disaster." (Thanouser. Two reels. Tues., Oct. 13.)—Quite a mystifying atmosphere is uppermost throughout this picture, which materially heightens the interest. The young American is warned not to accept a priceless diamond from an Indian as a token of gratitude. The dire results that it visited upon others are shown in fadeouts. The American takes it anyway, and while he is away from his home an outlaw attacks his house to gain possession of it. In his struggle with a confederate the house is blown up and it is thought that the wife and child of the man are dead, but they live to see the gem hurled into the water.

"Dash, Love and Splash." (Keystone. Split reel. Mon., Oct. 19.)—On the same reel with "Santa Catalina Island and Her Marine Gardens." "Dash, Love and Splash" is about all there is to this farce, little ostensible plot is present, although the action is laughable.

"Santa Catalina Island and Her Marine Gardens." (Keystone. Split reel. Mon., Oct. 19.)—On the same reel with "Dash, Love and Splash." A very beautiful scenic, and instructive, besides. Excellently photographed.

"Zip, the Dodger." (Keystone. Sat., Oct. 17.)—Roscoe Arbuckle appears as the Dodger, who lends his face as a target for supposedly soft balls. He falls in love and informs the girl that he is a "prune magnate," but he is shown up in his true colors and a general roughhouse ends the picture which is a laugh throughout.

"Sands of Fate." (Majestic. Two reels. Sun., Oct. 11.)—Although this drama is acted in an excellent manner by Dorothy Gish, Robert Harron and R. A. Walsh, the story seems rather weak and untrue, but this does not keep it from furnishing good entertainment. Because of the scheming of her suitor the girl marries him instead of the man she loves. Later when the husband sees where her love lies, he gracefully resigns in the other's favor. He wanders away and perishes in the desert.

"Down by the Sea." (American. Wed., Oct. 14.)—The fisherman who doubts the character of his sweetheart learns that her affections lie with the other man and so leaves them. This story is not told as convincingly as it could be. Winnifred Greenwood, Ed Coxen and George Field are the principals.

"Winsome Winnie." (Beauty. Tues., Oct. 13.)—Rather an antiquated plot but several humorous twists have made it interesting. How the young man wins the girl, despite her father, is the theme.

"Our Mutual Girl, No. 39." (Reliance. Mon., Oct. 12.)—This reel is entirely taken up with the situation that Margaret finds herself in when she is caught by a young man and accused of being a burglar. Quite a bit of humor. Margaret finally gets away when Ralph's sister identifies her, but she has with her the precious pin which she sought.

"Eric the Red's Wooing." (Domino. Two reels. Thurs., Oct. 29.)—An absorbing tale of the old Norsemen. Fine scenes and good photography unite to form a beautiful background for the picture. Eric, a hardy Viking, who is banished for presuming to ask for the hand of his chief's daughter, finally forces the leader to reinstate him by holding the girl as hostage on a small island. She learns to love him, much to the chagrin of her father.

"The Golden Goose." (Broncho. Two reels. Wed., Oct. 28.)—A cleverly constructed and unconventional offering which all will enjoy watching. The daughter of a banker pre-

sents a poor little girl with a goose, which is painted gold. The goose fails to lay golden eggs, but when she is killed by the child's starving brother, grains of gold are found in its crop, and gold is discovered where the goose was feeding. Really a fairly tale but it makes fine drama. A good love story is interwoven.

"The Worth of a Life." (Kay-Bee. Two reels. Fri., Oct. 30.)—Distinctly melodramatic, showing the circumstances that resulted from an unhappy marriage. The woman finally, at the suggestion of her blasé husband, returns to the man she loves. Although some of the action is not at all true to life, this picture holds one in suspense throughout.

"The One Who Cared." (Princess. Fri., Oct. 9.)—A country doctor's daughter breaks her engagement with a fine chap because of a foolish infatuation for a city man. Her father puts an apparently dangerous but actually harmless test of their love up to the two men. The city man fails and is dismissed, and the former lover and the girl find happiness together. Rene Farrington and Boyd Marshall are the principals.

"The Tardy Cannon Ball." (Reliance. Two reels. Sat., Oct. 10.)—While waiting for the belated "Cannon Ball Express," a stranger plays seven-up with the telegraph operator. He tells him the tragic story of his life, most of which has been spent in looking for a former friend who has wronged him, and whom he plans to kill. The operator discovers that he is the man, and the two men part as friends again.

"The Warning." (Majestic. Tues., Oct. 13.)—Dorothy Gish is featured in this effective story. A country girl is becoming infatuated with a traveling man. The usual course of elopement, abandonment and being turned out of home in disgrace takes place, but proves in the end to be only a dream. The girl sees her danger, and refuses to speak to her dangerous acquaintance again.

"The Unpainted Portrait." (Majestic. Tues., Oct. 6.)—A young artist abandons his wife. Later he meets his daughter without knowing who she is. He falls in love with her and is favored, but learns her identity when she poses for her picture in the costume worn by her mother on a similar occasion. A strong picture, well acted.

"Bill Spoils a Vacation." (Komic. Sun., Oct. 11.)—The eighth of the "Bill Series." The stenographer poses as a wealthy girl while on her vacation and becomes engaged to a rich widower. Bill's boss learns of it and sends him out to break the match up, as he does not want to lose his stenographer. Needless to say Bill succeeds. "Tammany Bill" Young and Fay Tincher are the principals.

"The Rescue." (Thanouser. Sun., Oct. 11.)—A girl and her sister-in-law become foolishly jealous of each other. When the sister-in-law is rescued from a burning launch by the other girl the two become fast friends. An episode with no plot.

"The Benevolence of Conductor No. 786." (Thanouser. Fri., Oct. 9.)—On the same reel with an education picture, "Lizards of the Desert." An old street car conductor is given a dinner by the younger men on the line. They plan to take up a collection for him, but he insists that the money be turned over to a poor widow who needs a rest in the country with her children.

"A Mother's Trust." (Majestic. Tues., Sept. 29.)—A youth is released from jail and his mother believes he has reformed. He goes back to crime and is fatally wounded when robbing the home of a man who has helped him. His pal is killed. By shifting revolvers he leads the police to believe that he died defending the man. His mother is thus comforted in his loss by her belief in his honor.

"Winsome Winnie." (Beauty. Tues., Oct. 20.)—This picture introduces a new leading Beauty player, Afton Mineer, in the role of Winnie Winsome. She is a very good little actress with plenty of personality. She has much difficulty in gaining her father's consent to her marriage. A number of good comic situations are brought out.

"Jailbirds." (American. Two reels. Wed., Oct. 14.)—A young attorney just moved into a Western town is the only one who has the nerve to represent the brute's wife in a divorce suit. The brute attempts to kill him, but accidentally the gun is turned on himself and the attorney is found guilty. He escapes and later befriends a girl and is compelled to

appear in court, where he is arrested. He serves his sentence and he and the girl marry. An interesting drama; good photography, and is well staged.

"The Balance of Power." (Princess. Fri., Oct. 2.)—A plucky girl saves her brother from financial failure by performing a daring swim. Rather a weak climax. Boyd Marshall and Rene Farrington are the principals.

"A Dog's Love." (Thanouser. Sun., Oct. 4.)—The Thanouser Kidlet, Helen Badgely, and Shep, the Collie dog, are the principals of this charming little picture, and both of them perform excellently. The picture is pathetic, as the little girl is killed, but the subtitle, "Don't cry, it's only make-believe," followed by a picture of the leads, brings it to a happy ending.

"Billy's Rival." (American. Wed., Oct. 7.)—True to the proverbial motion picture husband, that gentleman's suspicions are aroused in this picture, when he hears his wife delivering a dialogue to an unknown person, but it's only the neighbor's baby. Quite an indefinite ending to this picture, which contains a fair story, played by William Garwood and Vivian Rich.

"The Pet of the Petticoats." (Royal. Sat., Oct. 10.)—A poor attempt at comedy is made in this picture, and it is doubtful if many will enjoy it.

"Those Love Pangs." (Keystone. Sat., Oct. 10.)—Whenever Charles Chaplin and Chester Conklin combine their forces in a farce, it is certain to be one continual laugh, and so it is here. Perhaps the action may be termed "low" by some, but the story is nevertheless comical.

"In Old Italy." (Domino. Two reels. Thurs., Nov. 5.)—The canals and gondolas suggest Venice. A good story of the detective type. A young girl is captured by a disreputable Italian and it is because of a young gendarme's efforts that she is recovered.

"Harold's Toupee." (Royal. Sat., Oct. 24.)—Harold is nearly bald and decides that hair is needed if he is to be popular with the girls. He gets a wig which causes him many troubled moments. Then he finds a girl who loves him as he is. A good piece of comedy.

"Daylight." (American. Two reels. Mon., Oct. 19.)—Arthur, studying music, is more interested in club life. The artificial light is ruining his eyesight. He is struck blind while in the country, but finds light in his love for Marie. A pretty little love story with some very picturesque scenery and good photography.

"In the Open." (American. Wed., Oct. 21.)—A story of the plains in which love asserts itself. Ben Carroll meets Conchita accidentally while driving to a nearby town for a doctor to attend his sick mother. Conchita's brutal foster father, however, is not to be outwitted and regains the girl, only to lose her again to Carroll.

"Dad and the Girls." (Beauty. Tues., Oct. 20.)—A good little comedy in which dad is finally compelled to agree to his son's marriage to a stenographer, after the son has brought the girl into the office as a stenographer and dad makes love to her and mother catches him. Afton Miner, a new player in the Beauty ranks, plays the stenographer very well.

ECCLECTIC

"The Count That Took the Count." (Ecclectic. Sept. 30.)—A well handled comedy on the theme of the girl who overcomes her father's wishes that she marry a foreigner. The real count is locked up by a knight of the road, who takes his place without knowing it. This helps the daughter and her lover decidedly.

"In Soak." (Ecclectic. One reel.)—This is an entertaining comedy which contains a mixture of rather clever situations and slapstick humor. A man attempting to make a hit with a married woman offers her a pearl brooch. She dares not accept it but hits on the scheme of having her friend pawn it for only five dollars and then let her pretend to have found the ticket. The husband redeems the brooch readily enough but gives it to a stenographer in his office. When his wife discovers this war begins.

Our Factory Is Yours!

Negative assemblers, projecting machines and an equipment second to none, with an organization of experienced people always at your SERVICE for DEVELOPING and PRINTING.

EVANS FILM MFG. CO.

Incorporated
416-22 WEST 216th STREET
Tel. 7652 Audubon at Broadway, New York

COMPENSARC

That's the device that saves Moving Picture men two-thirds on their electric light bills, and yet gives better light. Did you see our ad last week? Well, don't look it up. Just write for our

Booklet 5027

FORT WAYNE ELECTRIC WORKS

OF GENERAL ELECTRIC CO.
1704 BROADWAY

FORT WAYNE INDIANA 733

FURNITURE & FURNISHINGS

On RENTAL
We equip your settings complete in accordance with your scenario.

WILLIAM BIRNS

103-105 West 37th St.
Phone: Greeley 6255.

SAVE TIME—SOLUTION

Use Corcoran Tank System

Get Price List No. 6

A. J. CORCORAN, Inc.

9½ John Street New York

LANG'S FILM REELS

THE BEST MADE

14 in. \$1.50 10 in. \$1.00

CATALOGUE

LANG MFG. WORKS, Orleans, N. Y.

One Exhibitor Nearly Starved

before he could make his theatre pay, Today he is one of the most successful theatre owners in the Central West.

His experiences, and those of many others, who had to fight every inch of their way to success, form an interesting and personally helpful feature of every issue of Motion Picture News.

The surest way to get each issue of this publication is to become a subscriber. The rate is exceptionally low—Two dollars a year. Just attach this advertisement to a bill, check, or money order for that amount and mail it to

The Sales Division

MOTION PICTURE NEWS

220 West Forty-Second Street New York City

NEWS WEEKLIES

"Animated Weekly, No. 135."—The ruins of the city of Termonde after twelve hours of terrific bombardment gives the spectator an idea of the power of modern siege guns; a scene in Minneapolis shows thousands of tons of food being shipped on its way to the war-stricken parts of Europe, and one sees General Joffre inspecting his forces. The usual clever pictures of Hy Mayer are, of course, a part of the program.

"Mutual Weekly, No. 93."—The war pictures are varied and thrilling. There is the first line of defense at Ostend, Bruges, Ghent and Malines; Belgian gunners destroying German ammunition wagons; and coils of wire being placed in the trenches by Germans to catch the enemy's shells. In contrast to such sanguinary subjects, there is a mammoth peace meeting at Grant's Tomb, New York City.

"Animated Weekly, No. 134."—The rest of the country will have an opportunity to see Coney Island's famous Mardi Gras this week. The carnival is graphically reproduced. In contrast to this exhibition of gaiety there is a disastrous railroad wreck in Livingston, Ala., where seven people were killed. Some of the other topical that will prove of interest are: the largest seagoing ferry, recently launched in Philadelphia; Admission Day celebration in California, and the changing of a British ship's registry in New Orleans.

"Mutual Weekly, No. 94."—A number of interesting views of foreign scenes are shown in this issue. Some which will attract unusual attention are the fortifications at Antwerp, German prisoners of war, ruins of Malines, Belgian soldiers joining the Allies at Ostend, and Canadian troops leaving for the Continent.

"Animated Weekly, No. 136."—The patrons of film drama will see in the issue of this week a number of interesting topical which cannot fail to cause wide comment for the variety of subjects and the excellent photography. Just now, with the championship series in the eye of all baseball fans, everybody will want to see the portraits of such men as Pitcher Bush, Amos Strunk and others. Fine scenes of Canada's war camp, the Belgians defending Louvain, and warships in the New York harbor are also shown.

INCORPORATIONS

At Dover, Del.:
SANSOM AMUSEMENT COMPANY, Philadelphia, Pa.; to own, operate and furnish moving pictures and places of amusement of all kinds; capital stock, \$5,000. Incorporators: V. A. Shuler, Howard P. Muhler, James A. Muhler, all of Philadelphia.

At Albany, N. Y.:
PRISMATIC FILM COMPANY, Manhattan; \$40,000; G. O. Leavitt, 254 4th avenue, New York; G. F. Leavitt, New York, and C. A. Field, Brooklyn.

At Harrisburg, Pa.:
THE URBAN FEATURE FILM & SERVICE COMPANY, Johnstown, Pa., capitalized at \$10,000 for the manufacture and distribution of motion picture films.

ALL STAR FEATURES

ETHEL BARRYMORE
in "The Nightingale"

By Augustus Thomas Five Reels

COMING

DIGBY BELL

in

"The Education of Mr. Pipp"

By Augustus Thomas Five Reels

James A. Herne's
SHORE ACRES

Five Reels

All Star Feature Corp.

220 West 42d Street New York

Moving Picture Scenarios

We are in the market for one and two reel comedies and comedy dramas.

Submit in typewritten form to

J. C. BROWNELL

105 Lawrence Avenue, Dept. C,
Dorchester, Mass.

Holland Film Manufacturing Co.

AFTER THE BALL

THE LITTLEST REBEL

SHOULD A WOMAN TELL

Are great box office attractions which need no introduction. Book them now.

Photoplay Productions Releasing Co.

37 S. Wabash Ave. Chicago

NO WAR BOOST ON OUR PRICES

Regardless of the present European unpleasantness we continue to use all essential chemicals such as

METOL AND HYDROQUINONE

and consistently maintain standard prices for quality

DEVELOPING AND PRINTING

Send today for our price, quality and service guarantee.

INDUSTRIAL MOVING PICTURE CO. 223-233 West Erie Street, Chicago

REBUILT MACHINES AS GOOD AS NEW

All machines entirely rebuilt and only Genuine Parts used.

Powers No. 6	\$125.00
Motigraph 1960 Model	100.00
Powers No. 5	65.00
Edison Exhibition	65.00
Powers No. 6 with 1912 Motigraph Lamp and Lamp House	135.00

Many others. Write for complete list. All of the machines are complete with the electrical attachments. A-1 adjustment guaranteed.

We carry a complete line of new Machines and supplies. Will take back your old machine in part payment of new one. Time or Cash.

Send for catalog today.

AMUSEMENT SUPPLY COMPANY

160 N. FIFTH AVENUE

CHICAGO

**THE ALBUQUERQUE FILM
MFG. COMPANY, Inc.**

Featuring that clever
Comedienne

Miss Dot Farley

Two Comedies Weekly

RELEASING THROUGH
The United Motion Picture Producers, Inc.
WHO DISTRIBUTE THROUGH
Warner's Features, Inc.

By request from many exchanges
we take pleasure in
reviving the

**FRONTIER
TWIN STORIES**

Written and made famous by Miss Dot
Farley. Under direction of

Gilbert P. Hamilton

Farce Comedy Production

BY

ARCHER McMACKIN

Nuf Sed

WESTERN STUDIO

406 Court St. Los Angeles, Calif.

GILBERT P. HAMILTON, Pres. and Gen. Mgr.

**CALIFORNIA CONVENTION HUMS WITH
BUSINESS**

(Continued from page 19.)

Mr. Rothschild be made an honorary member of the organization.

A member brought up the question of exchange service, protesting against the present arrangement whereby a certain number of reels must be taken each week, regardless of the needs of exhibitors. He expressed the opinion that more flexible rules might be adopted by exchange men if exhibitors insisted on it. M. E. Cory made a few remarks on this subject and stated that as the meeting was open to all it would probably be possible to have several exchange men on hand to give reasons for the existing arrangements.

The handling of reels on the part of exhibitors was then taken up as a subject for discussion and the proposition of having a system of inspection of machines was gone into. No action was taken on the inspection proposition and on motion of M. E. Cory the meeting was adjourned for the day.

Exchanges Make Fine Displays

As the exchange men contributed liberally toward the expenses of the convention they were allowed the privilege of making displays in the assembly hall and some very fine exhibits were installed. The World Film Corporation had two magnificent illuminated lobby stands.

The Box Office Attractions Company had a twenty-four sheet poster that was declared to be one of the best pieces of paper ever put out, and "Billy" Citron was on hand to tell all about the new exchange. The Golden Gate Film Exchange, Inc., the Mutual Film Corporation, the Syndicate Film Corporation, the Universal Film Manufacturing Company, the Progressive Motion Picture Company and the Nat. A. Magner Company, all had attractive displays and also had representatives on hand to meet exhibitors.

On Wednesday morning the sessions were resumed and the secretary read the minutes of the meeting of the day before. Mr. Beach, chairman of the committee having the proposition of issuing a monthly bulletin in charge, stated that the committee had found this matter feasible and suggested that this be taken up as soon as the finances of the league made it possible.

Tugwell the Star Orator

President Goddard then called upon A. P. Tugwell of Los Angeles, who had just arrived at San Francisco, and that gentleman delivered one of the finest speeches heard at the convention.

He outlined present conditions in Los Angeles, declaring that that city had more moving picture houses than any other city in the State, and probably more than any city of a corresponding size in the United States. He declared that he was not proud of this fact, however, that competition was very keen there, that many theatres did not pay and that there were frequent changes in management. He promised that next year a heavy delegation would be present at the State meeting from the Southern city.

In citing some of the benefits of organization, he told of the efforts of the chief of police of Los Angeles to secure the passage of a measure to segregate men and women in moving picture shows and how this was defeated through the organized effort of theatre owners. Mr. Tugwell told of how the efforts to enforce unfair union rules were thwarted.

He also related how three dangerous bills were defeated at the last Legislature through the efforts of the State League and how the moving picture men had found in Governor Johnson a true friend.

Secretary W. A. Cory then presented his annual report, showing the financial standing of the organization. He stated that during the past year the membership had decreased more than thirty per cent, and urged that exhibitors rally around the league and place it on a firm basis again. He declared that much good had been accomplished but that the work had been sadly handicapped through lack of funds. He stated that he was retiring from office and that under no consideration would he again accept the position. The gathering then adjourned in order that all might be on hand to take the boat trip in the afternoon.

M. L. LANGHORST.

What Do You Need?

LISTING IN THE BUYERS' GUIDE, FOR NAME AND ADDRESS, INCLUDING ONE YEAR'S SUBSCRIPTION TO THE MOTION PICTURE NEWS—\$8.00 A YEAR, CASH IN ADVANCE. FREE TO ADVERTISERS USING \$100.00 OR MORE WORTH OF DISPLAY SPACE DURING THE YEAR. ADDRESS ADVERTISING DEPARTMENT

ADVERTISING NOVELTIES

Philip Hano, 806-810 Greenwich St., New York.

ANNOUNCEMENT SLIDES

Niagara Slide Co., Lockport, N. Y.

ASBESTOS BOOTHS

Sharlow Bros., 442 W. 42nd St., New York.

CLEANING AND RENOVATING FILM

Film Redeveloping Co. of America, 145 W. 45th St., N. Y.
 Multicolor Film Improving Co., Inc., 15 E. 26th St., N. Y.

COSTUMERS

Miller-Costumier, 236 South 11th St., Philadelphia, Pa.

DEVELOPING TANKS

A. J. Corcoran, Inc., 9 1/2 John St., New York.

ELECTRIC LIGHTING SETS

The Chas. A. Strelinger Co., Box P-2, Detroit, Mich.

FILMS

(Manufacturers, Dealers and Renters)
 American Film Mfg. Co., Chicago, Ill.
 Thomas A. Edison, Inc., 275 Lakeside Ave., Orange, N. J.
 Essanay Film Mfg. Co., First National Bank Bldg., Chicago, Ill.
 General Film Co., 200 Fifth Ave., New York.
 George Kleine, 166 N. State St., Chicago, Ill.
 Lubin Mfg. Co., Philadelphia, Pa.
 G. Melies, 204 E. 38th St., New York.
 Mutual Film Corp., 71 W. 23rd St., New York.
 New York Motion Picture Corp., Longacre Bldg., New York.
 Pathé Freres, 1 Congress St., Jersey City, N. J.
 Renfax Film Co., Inc., 110 W. 40th St., N. Y.
 Selig Polyscope Co., Chicago, Ill.
 Thanhouser Film Corp., New Rochelle, N. Y.
 Universal Film Mfg. Co., 1600 Broadway, N. Y.

FILM ACCESSORIES

Berlin Aniline Works, 213 Water St., N. Y.

FILM TILES, PRINTING, DEVELOPING, ETC.

Commercial Motion Pictures Co., Inc., 220 W. 42nd St., New York.
 Centaur Film Co., 670-682 Ave. E, Bayonne, N. J.
 Evans Film Mfg. Co., 412-22 W. 216th St., at Broadway, New York.
 Gunby Bros., Inc., 145 W. 45th St., New York.
 Industrial Moving Picture Co., 223-233 W. Erie St., Chicago.
 Standard Motion Picture Co., 5 S. Wabash Ave., Chicago.
 Standard Filmprint Corp., 120 School St., Yonkers, N. Y.

FILM REELS

Lang Mfg. Works, Olean, N. Y.
 Taylor-Shantz Company, 224 Mill St., Rochester, N. Y.

FURNITURE AND FURNISHING ON RENTAL

William Birns, 103-105 West 37th St., N. Y.

FEATURE FILMS

Alco Film Corp., 218 W. 42d St., New York.
 Alliance Films Corp., 126 W. 46th St., New York.
 Albuquerque Film Mfg. Co., Inc., 406 Court St., Los Angeles, Calif.
 All Star Feature Corp., 220 W. 42nd St., N. Y.
 Ambrosio American Co., 15 E. 26th St., N. Y.
 Bosworth, Inc., 640 N. Olive St., Los Angeles, Cal.
 Box Office Attraction Film Rental Co., 130 W. 46th St., New York.
 A. Blinkhorn, 110 W. 40th St., New York.
 California Motion Picture Corp., San Francisco, Cal.

Cosmofotofilm Co., 110 W. 40th St., New York.
 Cosmos Feature Film Corp., 126-130 W. 46th St., N. Y. City.

Direct-From-Broadway Features Co., 46 W. 24th St., New York.

Eclair Film Co., 126 W. 46th St., New York.
 Eclectic Film Co., 110 W. 40th St., New York.
 Excelsior Feature Film Corp., Inc., 110 W. 40th St., N. Y.

G. W. Feature Film Corp., 145 W. 45th St., N. Y.

Features Ideal, 126 W. 46th St., New York.
 Famous Players Film Co., 213-229 W. 26th St., New York.

Films Lloyds, Inc., 220 W. 42nd St., N. Y.
 General Film Co., 200 Fifth Ave., New York.
 General Feature Film Co., 313 Mallery Bldg., Chicago, Ill.

Gaumont Co., 110 W. 40th St., New York.
 Greene's Feature Photo Plays, Inc., 110 W. 40th St., New York.

W. W. Hodgkinson, 110 W. 40th St., New York.
 Imperial Motion Picture Co. of N. Y., Inc., 1476 Broadway, N. Y.

Inter-Continent Film Co., 110 W. 40th St., New York.

George Kleine Attractions, 166 N. State St., Chicago, Ill.
 -New York Office: 1476 Broadway.

Jesse L. Lasky Feature Play Co., Longacre Theatre, New York.

Life Photo Film Corp., 220 W. 42nd St., N. Y.
 Mecca Feature Film Co., Inc., 126 W. 46th St., New York.

Mohawk Film Co., Times Bldg., New York.
 Oz Film Mfg. Co., Santa Monica Blvd., Los Angeles, Cal.

Paramount Pictures Corp., 110 W. 40th St., New York.

Phoenix Feature Film Corp., 129-131 Columbus Ave., Boston, Mass.
 Photo Play Production Co., 220 W. 42nd St., New York.

Picture Playhouse Film Co., 110 W. 40th St., New York.

Playgoers Film Co., Lyric Theatre, New York.
 Popular Plays and Players Co., 1600 Broadway, New York.

Progress Film Co., 110 W. 40th St., New York.
 Progressive Motion Picture Corp., Times Bldg., New York.

Ramo Films, Inc., Columbia Theatre Bldg., New York.
 Rolands Feature Film Co., 145 W. 45th St., New York.

A. H. Sawyer, Inc., 1600 Broadway, New York.
 Select Photo Play Producing Co., Inc., 71 W. 23rd St., New York.

Sterling Camera & Film Co., 145 W. 45th St., New York.

Solax Co., Fort Lee, N. J.
 The Masterpiece Film Mfg. Co., 1111 Van Nuys Bldg., Los Angeles, Cal.

The Photoplay Productions Releasing Co., 37 S. Wabash Ave., Chicago, Ill.
 Union Features, 126 W. 46th St., New York.

Universal Film Mfg. Co., 1600 Broadway, N. Y.
 University Films, Inc., 110 W. 40th St., N. Y.
 Edw. H. Wagner, Agt., Dania Biofilm Co., 38 Park Place, N. Y.

World Film Corporation, 130 W. 46th St., New York.
 Warner's Features, Inc., 130 W. 46th St., N. Y.

LANTERN SLIDE MATS AND REEL BANDS

Lantern Slide Mat Co., 149 W. 35th St., N. Y.

LABELS

Every Ready Roll Label Co., 203-7 W. 40th St., New York City.

LIGHTING PLANTS

Cushman Motor Works, Lincoln, Neb.

LOBBY PHOTOS

The Wyanoak Pub. Co., 136 W. 52nd St., N. Y.

MOTION PICTURE MACHINES AND SUPPLIES

Amusement Supply Co., 160 E. North Fifth Ave., Chicago, Ill.

Calehuff Supply Co., 1301 Race St., Philadelphia, Pa.

Enterprise Optical Co., 568 W. Randolph St., Chicago, Ill.

Lears Theatre Supply Co., Sam Lears, Prop., 509 Chestnut St., St. Louis, Mo.

Oliver Moving Picture Supply Co., 647 Euclid Ave., Cleveland, O.

Picture Theatre Equipment Co., 21 E. 14th St., New York.

Precision Machine Co., 317 E. 34th St., N. Y.

Nicholas Power Co., 90 Gold St., New York.

The Phantoscope Mfg. Co., Washington, D. C.

Sweeley's Photo Supply House, 514-516 Erie Ave., Renova, Pa.

Williams. Brown & Earle, Inc., 916-918 Chestnut St., Philadelphia, Pa.

MOTION PICTURE APPARATUS

Burke & James, Inc., 240-258 E. Ontario St., Chicago, Ill.

MUSICAL INSTRUMENTS

American Photo Player Co., 62 W. 45th St., New York City.

Rudolph Wurlitzer Co., Cincinnati, O.

POSTER AND PICTURE FRAMES

Menger & Ring, 442 W. 42nd St., New York.

RAW FILM

Eastman Kodak Co., Rochester, N. Y.

Cellulose Planchon, Inc., 75 Fifth Ave., New York.

David Horsley, 1600 Broadway, N. Y.

Raw Film Supply Co., 15 E. 26th St., N. Y.

OPERA CHAIRS

The Hardesty Mfg. Co., Canal Dover, Ohio.
 Steel Furniture Co., Grand Rapids, Mich.

PIPE ORGANS

Henry Pilcher's Sons, 914-920 Mason Ave., Louisville, Ky.

M. P. Moller, Hagerstown, Md.

PROJECTION LENSES

Bausch & Lomb Optical Co., 569 St. Paul St., Rochester, N. Y.

POSTERS

The Morgan Lithograph Co., Cleveland, Ohio.

REWINDERS AND GENERAL SUPPLIES

L. C. Smith Co., Schenectady, N. Y.

SCREENS

Atsco, Inc., 218 West 42nd St., New York.

Day & Night Screens, Inc., 110 W. 40th St., New York.

Mirror Screen Co., Inc., Shelbyville, Ind.

STEEL FILM EQUIPMENT FOR EXCHANGES AND MFRS.

Columbia Metal Box Co., 226-228 E. 144th St., New York.

TICKETS—ROLL AND COUPON

Rees Ticket Co., 400 S. 10th St., Omaha, Neb.

THEATRE LOBBY FRAMES AND FIXTURES

Newman Mfg. Co., 715 Sycamore St., Cincinnati, O.

UNIFORMS

Fechheimer Bros., Union-made Uniforms, Cincinnati, O.

VENTILATION, COOLING AND HEATING

Typhoon Fan Co., 1544 Broadway, N. Y.

Record of Current and Coming Releases

GENERAL FILM PROGRAM

RELEASES OF THE WEEK

Monday, October 12, 1914.

BIOGRAPH—The Guiding Fate, D., 1004.....	16176
EDISON—Buster Brown's Education, C., 500.....	16182
George Washington Jones, C., 500.....	
ESSANAY—Sweetie Learns to Swim, C., 1000.....	16184
KALEM—The Girl and the Stowaway, C., 2000.....	16177
LUBIN—The Girl from the West, Fifth of the Beloved Adventurer Series, D., 1000.....	16185
SELIG—The Dream Girl, D., 2000.....	16179
VITAGRAPH—Midst Woodland Shadows, D., 1000	16181

Tuesday, October 13, 1914.

BIOGRAPH—The Iron Master, D., 2017.....	16196
COLUMBUS—Why Skunkville Went Dry, C., 1000	16194
EDISON—The Letter That Never Came Out, D., 1000	16186
ESSANAY—Through Eyes of Love, D., 1000.....	16187
KALEM—Percy Pimpernickel-Soubrette, C., 1000..	16195
KLEINE—On the Battle Line, D., 2000.....	16188
LUBIN—Swami Sam, C., 400.....	16193
Neighborly Neighbors, C., 600.....	
SELIG—The Mexican, D., 1000.....	16190
VITAGRAPH—Mareca, the Foster Mother, D., 2000	16191

Wednesday, October 14, 1914.

EDISON—Andy and the Redskins, C., 1000.....	16198
ESSANAY—The Fable of "The Author and the Dear Public and the Plate of Mush," C., 1000	16201
KALEM—Seed and the Harvest, D., 2000.....	16199
LUBIN—The Bond of Womanhood, D., 2000.....	16204
SELIG—The Mysterious Beauty, C., 1000.....	16203
VITAGRAPH—The Peacemaker, C., 1000.....	16202

Thursday, October 15, 1914.

BIOGRAPH—The First Law, D., 1000.....	16206
ESSANAY—Snakeville's Peacemaker, C., 1000.....	16207
LUBIN—The Imposter, D., 2000.....	16208
SELIG—Hearst-Selig News Pictorial No. 66, N., 1000	16211
VITAGRAPH—His Dominant Passion, D., 1000...	16210

Friday, October 16, 1914.

BIOGRAPH—Peg O' the Wild-Wood, D., 1000....	16220
EDISON—On the Isle of Sarne, C., 2000.....	16212
ESSANAY—The Other Man, D., 2000.....	16214
KALEM—Si's Wonderful Mineral Spring, C., 1000.	16216
LUBIN—The Long Lane, D., 1000.....	16219
SELIG—The Man-Hater, C., 1000.....	16217
VITAGRAPH—Fatty's Sweetheart, C., 1000.....	16218

Saturday, October 17, 1914.

BIOGRAPH—Meeting Mr. Jones, C., 469.....	16227
Our Home-Made Army, C., 532.....	
EDISON—The Case of the Vanished Bonds, D., 1000	16221
ESSANAY—Broncho Billy Rewarded, D., 1000....	16222
KALEM—From Peril to Peril, D., 1000.....	16226
LUBIN—The Smuggler's Daughter, C., 1000.....	16223
SELIG—The Woman of It, D., 1000.....	16228
VITAGRAPH—The Girl in the Case, D., 2000.....	16224

RELEASES OF NEXT WEEK

Monday, October 19, 1914.

BIOGRAPH—Their Soldier Boy, D., 1001.....	16229
EDISON—The Adventure of the Smuggled Diamonds, D., 1000.....	16235
ESSANAY—She Landed a Big One, C., 1000.....	16237
KALEM—The Mad Mountaineer, D., 1800.....	16230
LUBIN—The Golden Hope, Beloved Adventurer No. 6, D., 1000.....	16238
SELIG—The Blue Flame, D., 2000.....	16232
SELIG—Hearst-Selig News Pictorial No. 67, N., 1000	16236
VITAGRAPH—His Wedded Wife, D., 1000.....	16234

Tuesday, October 20, 1914.

BIOGRAPH—Martin Chuzzlewit, D., 1045.....	16247
COLUMBUS—Love Charm, C., 1000.....	16245
EDISON—The Man In the Dark, D., 1000.....	16239
ESSANAY—Mother O' Dreams, D., 1000.....	16240
KALEM—A Wise Rube, C., 1000.....	16246
LUBIN—Such a Mess, C., 400.....	16244
Only Skin Deep, C., 600.....	
SELIG—Jimmy Hayes and Muriel, D., 1000.....	16241
VITAGRAPH—Anne of the Mines, D., 2000.....	16242

Wednesday, October 21, 1914.

EDISON—Two's Company, C., 1000.....	16249
ESSANAY—The Fable of "The Long Range Lover and the Lollypalooze," C., 1000.....	16252
KALEM—The False Guardian, D., 2000.....	16250
LUBIN—The Hopeless Game, D., 2000.....	16255
SELIG—The Rajah's Vacation, C., 1000.....	16254
VITAGRAPH—Under False Colors, C., 1000.....	16253

Thursday, October 22, 1914.

BIOGRAPH—They Called It "Baby," C., 498.....	16257
His Loving Spouse, C., 501.....	
ESSANAY—Slippery Slim, the Mortgage and Sophie, C., 1000.....	16258
LUBIN—Her Mother Was a Lady, D., 2000.....	16259
SELIG—Hearst-Selig News Pictorial No. 68, N., 1000	16262
VITAGRAPH—The Mill of Life, D., 1000.....	16261

Friday, October 23, 1914.

BIOGRAPH—A Woman's Folly, D., 998.....	16271
EDISON—Bootle's Baby, D., 2000.....	16263
ESSANAY—The Private Officer, D., 2000.....	16265
KALEM—Micky Flynn's Escape, C., 1000.....	16267
LUBIN—The Girl in the Tenement, D., 1000.....	16270
SELIG—A Tonsorial Leopard Tamer, C., 1000....	16268
VITAGRAPH—A Costume Piece, C., 1000.....	16269

Saturday, October 24, 1914.

BIOGRAPH—The Broken Rose, D., 996.....	16278
EDISON—Buster Brown's Uncle, C., 500.....	16272
A Question of Clothes, C., 500.....	
ESSANAY—Broncho Billy-Favorite, D., 1000.....	16273
KALEM—The Demon of the Rails, D., 1000.....	16277
LUBIN—The Crooks, C., 1000.....	16274
SELIG—The Tragedy That Lived, D., 1000.....	16279
VITAGRAPH—Goodbye Summer, D., 2000.....	16275

"THE SCARECROW OF OZ"

(Oz Film—Five Reels)

REVIEWED BY WILLIAM RESSMAN ANDREWS

THE Never-Never Land of quaint fancy is a place of delightful retirement from the harsh realities of a work-a-day world. This realm of poesy and odd conceits, whose surprises are limited only by the exuberance of an author's imaginative flights, has been explored by L. Frank Baum with pleasing results.

In "The Scarecrow of Oz" he has found a region of quips and quirks, a place so full of whimsical abandonment that adults will give themselves up to the illusion of its fairy land with as much absorption as children.

Indeed, in some respects this latest production of the Oz Film Company will make a stronger appeal to grown-ups. Here and there are sly touches of humor which can be appreciated only by the matured mind, as in the case of Stevenson's "A Child's Garden of Verses," and Lewis Carroll's "Alice in Wonderland" and "Alice Through the Looking Glass."

A man or woman can sit through "The Scarecrow of Oz" or "The Patchwork Girl of Oz" and get more real enjoyment out of the extravaganza than from many pretentious dramas. No doubt a large percentage of parents who have seen the first of the Oz series will take the children to the second one much in the same spirit that so many of us go to the circus—merely to "please the youngsters"—without admitting that we really want to see it ourselves.

Like the best fairy tales, so dear to our childhood recollection—those that mothers have told the youngsters at their knees from time immemorial, and the eager fancy of youth never tires of hearing—a tender love story runs through the play.

There is the old, old theme—old but never threadbare—of parental opposition preventing the "course of true love from running smooth." King Krewl does not like his daughter's suitor and calls in the services of a heartless witch to make the beautiful princess forget the object of her affections.

And the old witch does it effectively—with all the expertness of her tribe in the days when those things could be done—in fairy land. The grinning hag, accoutred with all the traditional regalia of her office, peaked hat and bizarre garments, goes to her task with a diabolical zest.

The magic wand conjures up her ally, Old Nick himself, and she ladles from a regular Macbeth witches' caldron the direful potion which shall make the girl forget all mortal love. This is poured on her breast, and the mixture freezes the heart of the princess. Then the witch removes the heart.

This seems impossible, yet it is true. If you don't believe it ask any young child in the audience—deeply learned in all knowledge of fairy land and the mean ways of witches—for the poor girl's heart is taken out before your very eyes; so it must be true!

This is only one touching whimsy in this masterpiece of "lovable foolery." Space forbids mention of other incidents except the scene where the Scarecrow is brought to life by the Spirit of the Corn.

What a wonderful place to sojourn in, this topsy-turvy land where happy children wander about accompanied by friendly lions, frisky kangaroos and wise mules who know that malicious witches deserve to be properly kicked for all the trouble they bring in the lives of deserving lovers!

TWO LOS ANGELES THEATRES RAISE PRICES

Special to MOTION PICTURE NEWS

Los Angeles, Oct. 12.

TWO more retail district motion picture theatres of Los Angeles have announced their intention of increasing prices. The Woodley, 833 South Broadway, which has been showing feature pictures only for the past six months, at ten, fifteen and twenty cents for evening performances and ten cents for matinees, has raised the price for performances to ten cents general admission, fifteen cents rear seats, and twenty-five cents loges.

The Symphony, opened in August, is charging ten cents for general admission, twenty for rear seats and twenty-five for loges, instead of ten, fifteen and twenty cents. The change has proved a good move.

Rejoice with the RADIUM GOLD FIBRE SCREEN

on its 7th Birthday
by having one
placed in your the-
atre. You get a per-
fect projection and
save ONE HALF
of your electric bill.

Send to Our Nearest Office
for a Demonstration

ATSCO., INC.
ALCO BLDG.

218 W. 42nd Street, N. Y. C.

RECORD OF CURRENT AND COMING RELEASES—Continued

UNIVERSAL PROGRAM RELEASES OF THE WEEK

Monday, October 12, 1914.

IMP—Mary's Convert, Mary Pickford Reissue, D..
STERLING—The Close Call.....
VICTOR—His Father's Son, D.....

Tuesday, October 13, 1914.

CRYSTAL—Oh, You Gypsy Girls and Some Col-
lectors, C.....
GOLD SEAL—Trey o'Hearts Episode No. 11, D.,
2000

UNIVERSAL IKE—Mary Green's Husband and
the Monkey Cabaret, C., Split Reel.....

Wednesday, October 14, 1914.

ECLAIR—The Squatter, D., 3000.....
JOKER—On Again, Off Again, Finnigan, C.....
NESTOR—No Release This Week.....

Thursday, October 15, 1914.

IMP—The Futility of Revenge, D., 2000.....
REX—Her Life's Story, D.....
STERLING—Heinie's Outing, C.....

Friday, October 16, 1914.

NESTOR—The Way of Life, D.....
POWERS—The Padrone's Ward, D., 2000.....
VICTOR—The Funny Mr. Dingle, C.....

Saturday, October 17, 1914.

101 BISON—Monsieur Bluebeard, D., 2000.....
JOKER—Across the Court, C.....

Sunday, October 18, 1914.

ECLAIR—The Quarrel, D.....
FRONTIER—In the Hollow of an Oak, D.....
REX—Kid Regan's Hands, D., 2000.....

RELEASES OF NEXT WEEK

Monday, October 19, 1914.

IMP—Country Innocence, D., 2000.....
STERLING—The Mistaken Bath House, C.....
VICTOR—Rice Industry in the U. S., E.....

Tuesday, October 20, 1914.

CRYSTAL—Vivian's Transformation, C.....
GOLD SEAL—The Trey O' Hearts, Episode No.
12, D., 2000.....
NESTOR—The Nihilists, D.....

Wednesday, October 21, 1914.

ANIMATED WEEKLY—No. 137, N.....
ECLAIR—The Violinist, D., 2000.....
JOKER—The Countless Count, C.....

Thursday, October 22, 1914.

IMP—Universal Boy in "The Gates of Liberty"....
REX—Olaf Erickson, Boss, D., 2000.....
STERLING—Secret Service Snitz, C.....

Friday, October 23, 1914.

NESTOR—Cupid Pulls a Tooth, and Educational..
POWERS—Suspended Sentence.....
VICTOR—The Bride of Marblehead, D., 2000.....

Saturday, October 24, 1914.

101 BISON—My Lady Raffles in The Mysterious
Hand, D., 3000.....
FRONTIER—The Scarecrow's Secret, D.....

Sunday, October 25, 1914.

ECLAIR—Smallpox on the Circle U, C.....
L. KO—Love and Surgery, C., 2000.....
REX—The Little Blonde Lady, D.....

MUTUAL PROGRAM RELEASES OF THE WEEK

Monday, October 12, 1914.

AMERICAN—Jail Birds, D., 2000.....
KEYSTONE—The Anglers.....
RELIANCE—Our Mutual Girl No. 39.....

Tuesday, October 13, 1914.

BEAUTY—Winsome Winnie, C.....
MAJESTIC—The Warning, D.....
THANHAUSER—The Diamond Disaster, D., 2000.

Wednesday, October 14, 1914.

AMERICAN—Down by the Sea, D.....
BRONCHO—The End of the Galley, D., 2000.....
RELIANCE—Bad Man Mason, D.....

Thursday, October 15, 1914.

DOMINO—Jimmy, D., 2000.....
KEYSTONE—High Spots on Broadway, C., 1000..
MUTUAL WEEKLY—No. 94.....

Friday, October 16, 1914.

KAY BEE—The Word of His People, D., 2000....
PRINCESS—The Touch of a Little Hand, D.....
MAJESTIC—Back to the Kitchen, C.....

Saturday, October 17, 1914.

KEYSTONE—Dash, Love and Splash and Santa
Catalina Islands, Split Reel

RELIANCE—The Revenue Officer's Deputy, D.,
2000

ROYAL—The Black Hand, C.....

Sunday, October 18, 1914.

KOMIC—Dizzy Joe's Career, C.....
MAJESTIC—For His Father's Sins, D., 2000.....
THANHOUSER—Left in the Train, C.....

RELEASES OF NEXT WEEK

Monday, October 19, 1914.

AMERICAN—Daylight, D., 2000.....
KEYSTONE—Dash, Love and Splash, C., 1000.....
RELIANCE—Our Mutual Girl No. 40.....

Tuesday, October 20, 1914.

BEAUTY—Dad and the Girls, C.....
MAJESTIC—Environment, D.....
THANHOUSER—Old Jackson's Girl, D., 2000.....

Wednesday, October 21, 1914.

AMERICAN—In the Open, D.....
BRONCHO—Shorty and Sherlock Holmes, C., 2000
RELIANCE—Out of the Deputy's Hands, D.....

Thursday, October 22, 1914.

DOMINO—The Power of the Angelus, D., 2000....
KEYSTONE—Love Siege, C., 1000.....
MUTUAL WEEKLY—No. 95.....

Friday, October 23, 1914.

AMERICAN—The Final Impulse, D.....
KAY BEE—The Spark Eternal, D., 200.....

Saturday, October 24, 1914.

KEYSTONE—Stout Heart But Weak Knees, C.,
1000

RELIANCE—A Blotted Page, D., 2000.....

ROYAL—Harry's Toupee, C.....

Sunday, October 25, 1914.

KOMIC—Bill Joins the W. W. W.'s No. 9, C.....
MAJESTIC—A Flight for a Fortune, D., 2000.....
THANHOUSER—Mr. Cinderella, D.....

A. I. Runyon Advertising & Sales Co., Inc., Successors to
ACME COMMERCIAL FILM CO.
 Prices to The Trade
POSITIVE PRINTS .04½ Per Foot
 (In Quantities over 5000 feet)
 Above price includes printing, develop-
 ing, tinting, toning and Raw Positive
 Negative Film Developed .01 Per Ft.
 Film Titles .08
 (Our Special Title Apparatus will match
 any perforation.) All work guaranteed.
 General Offices, 2624 Milwaukee Ave., Chicago
 Phone Albany 3125

ACTUAL WAR FILMS
 are coming to hand in London. You must have them post-haste. Only selected films purchased. Can recommend:
 German Occupation Louvain.....\$63.40
 Germans Entering Brussels.....\$34.82
 Ruins of Temonde.....\$30.84
WAR FILMS OF THE MOMENT.
 Servian Army.....\$45.52
 Indian Army.....\$55.00
 Japanese Army.....\$45.52
 British Navy.....\$60.24
 British Cavalry.....\$47.24
 Italian Navy and Army.....\$64.64
 Also Other Nations' Sea and Land Forces.
 Above Prices Inclusive of Reg. Letter Post.
THE LATEST WAR FILMS DISPATCHED AS RECEIVED.
 Terms—Cash only, draft, or your bank's cable order for payment against invoice on London Bank.
HIRAM HORTON, FILM BROKERS, ARTOGRAGH HOUSE, 8 NEW CROMPTON ST., LONDON, W. C. BANKERS: LLOYDS' BANK, Oxford St., London.

"New Film For Old"

 Films Improved, Cleansed and Softened
Multicolor Film Improving Co., Inc.
 15 East 26th Street New York
 Philadelphia Branch Albert Teitl President
 1126 Vine Street

THE CHEAPEST PLACE TO BUY BEST QUALITY ROLL TICKETS IS The Pioneer Ticket Co. 722 Broadway, New York
 Perfect Numbering Quick Delivery

BARRIE VISITS FAMOUS PLAYERS

Sir James M. Barrie, the distinguished English dramatist, whose every visit to America is a distinct event in theatrical and literary circles, got his first glimpse of a motion picture studio when he visited the Famous Players Film Company recently. Sir James spent several hours with Adolph Zukor and Daniel Frohman, and made a complete tour of the Famous Players' immense studio and laboratory.

Sir James termed his visit "a peep into fairyland," and often expressed astonishment at the methods and mechanism of the big plant.

The eminent dramatist, who is the author of a greater number of theatrical successes than any other living writer for the stage, was introduced to the various Famous Players directors, and also Mary Pickford.

PARAMOUNT BOOKLET MAKES FINE SOUVENIR

A unique bit of advertising has been issued by Paramount Pictures Corporation. It consists of a dainty booklet, vest-pocket size, entitled "The Story of Paramount," profusely illustrated with half-tones of the prominent actors and actresses appearing in the productions of the companies releasing through Paramount.

Short notices accompanying the portraits make interesting reading for those who desire to refresh their recollection of the accomplishments of the various players. The booklet because of its handsome appearance and the high quality of its contents will appeal to the general public as a desirable souvenir of a "Paramount evening."

"AFTER THE BALL" HAS BIG BOOKINGS

"After the Ball," featuring Kelcey and Shannon, produced by the Photo Drama Company under Pierce Kingsley's direction, is having great success throughout the country. The hundreds of letters coming in every day to the Photo Drama office attest this. There are over two hundred bookings alone listed at the New York office, while the reports from the out of town offices are double that of any other feature ever sent out from the office of the Photo Drama Company.

Preparations are being made to cover the coast country and Canada. Big Bill Steiner and Jim Maher are the men at the helm, while its publicity is being covered by Pierce Kingsley.

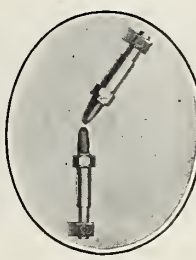
Save 35%
 on your
CARBONS
 Burn your stubs with a
CARBON Economizer

 Pat. Appd. for
 Fits any lamp, gives perfect contact and conductivity, screw does not come in contact with carbon and will not weld to body of economizer, will burn UPPER or LOWER carbon from 6 inches to ¾ of an inch, is simple, practical, will last years with perfect results, and pay for itself in a few days.
"MECHANICALLY CORRECT"!!
 \$1.25 Sizes \$2.00
 Each. ½", ¾", ¾". Upper and Lower Set.
 Sent **POSTPAID** upon receipt of draft, money order or cash.
THE CARBON ECONOMIZER CO.
 757 W. Onondaga St., Syracuse, N. Y.

Make Your Lobby Display Attractive
 There is nothing more fascinating to the public than a bright brass frame to display your photos or posters.
 We make Lobby and Theatre Fixtures and Brass Rails of every description.
 Don't fail to visit our Showrooms.
 Write for catalog.
THE NEWMAN MFG. CO.
 717 Sycamore St. Cincinnati, Ohio
 Branch Factories and Show Rooms: 101 Fourth Ave. New York, N. Y. 106-108 W. Lake St. Chicago, Ill. Established 1882.



ARE YOU HAVING BOOKING TROUBLE?
 Are you getting the films you want—or are paying for?
 Save trouble, time and money by booking your films through the
Managers Booking Bureau
 Suite 1012, Hartford Building, Chicago
PHONE—CENTRAL 2448
 Motion Picture Booking for the States of Illinois, Indiana and Michigan.
 Films Reviewed.
 Exhibitors' Supply Service.
 Information regarding any branch of the Motion Picture business.
 Write now for particulars.

Your negative developed, printed and titled complete
5c per foot delivered within **12** hours
 Titles **6c** per foot
GUNBY BROS., Inc.
 145 West 45th Street New York City

HEADQUARTERS FOR POWERS, MOTIOPH, SIMPLEX AND EDISON MACHINES
PICTURE THEATRE EQUIPMENT CO.
 THE BIGGEST MOTION PICTURE SUPPLY HOUSE IN AMERICA
21 EAST 14th STREET, NEW YORK CITY
 CONDENSERS—BOOTHS—TICKET CHOPPERS—REELS—REEL CASES—BOOTH CABINETS
WE EQUIP MOTION PICTURE THEATRES COMPLETELY

RELEASE DATES FOR READY REFERENCE

GENERAL FILM PROGRAM

BIOGRAPH

- 10-12. The Guiding Fate, D.....1004
- 10-13. The Iron Master, D.....2017
- 10-15. The First Law, D.....1000
- 10-16. Peg o' the Wild Wood, D.....1000
- 10-17. Meeting Mr. Jones, C.....469
- 10-19. Our Home-Made Army, C.....532
- 10-19. Their Soldier Boy, D.....1001
- 10-20. Martin Chuzzlewit, D.....2045
- 10-22. They Called it "Baby," C.....498
- 10-23. A Woman's Folly, D.....998
- 10-24. The Broken Rose, D.....996

COLUMBUS

- 10- 8. The New Apprentice, C.....750
- 10-13. Why Snakeville Went Dry, C.....1000
- 10-20. Love Charm, C.....1000

EDISON

- 10-13. The Letter That Never Came Out, D.....1000
- 10-14. Andy and the Redskins, C.....1900
- 10-16. On the Isle of Sarnae, C.....2000
- 10-17. The Case of the Banished Bonds, D.....1000
- 10-19. The Adventures of the Smuggled Diamonds, D.....1000
- 10-20. The Man in the Dark, D.....1000
- 10-21. Two's Company, C.....1000
- 10-23. Bootles' Baby, D.....2000
- 10-24. Buster Brown's Uncle, C.....500
- 10-26. Wood B. Wedd and the Microbes, C.....1000
- 10-27. The Mystery of the Sealed Art Gallery, D.....1000
- 10-28. The Lost Melody, D.....1000
- 10-30. The Midnight Ride of Paul Revere, D.....2000
- 10-31. The Hand of Iron, D.....1000
- 11- 3. Shorty, D.....1000
- 11- 4. Jenks and the Janitor, C.....500
- 11- 7. Getting to the Ball Game, C.....1000
- 11- 9. With Slight Variations, C.....1000
- 11-10. The Heritage of Hamilton Cleek, D.....1000
- 11-13. A Question of Identity, D.....2000

ESSANAY

- 10- 9. The Real Agatha, D.....2000
- 10-10. Broncho Billy and the Greaser, D.....1000
- 10-12. Sweedie Learns to Swim, C.....1000
- 10-13. Through Eyes of Love, D.....1000
- 10-14. The Fable of "The Author and the Dear Public and the Plate of Mush, C.....1000
- 10-15. Snakeville's Peace-Maker, C.....1000
- 10-16. The Other Man, D.....2000
- 10-17. Broncho Billy Rewarded, D.....1000
- 10-19. She Landed a Big One, C.....1000
- 10-20. Mother o' Dreams, D.....1000
- 10-21. The Fable of "The Long Range Lover and the Lalypalooze," C.....1000
- 10-22. Slippery Slim, the Mortgage and Sophie, C.....1000
- 10-23. The Private Officers, D.....2000
- 10-24. Broncho Billy—Favorite, D.....1000

KALEM

- 10- 6. For the Love of Mike, C.....8000
- 10- 7. Hesanut Hunts Kild Game, C.....200
- 10- 7. The Lost Mail Sack, D.....2000
- 10- 9. The Tattered Duke, C.....1000
- 10-10. Fate's Midnight Hour, D.....1000
- 10-12. The Girl and the Stowaway, Alice Joyce Series, C.....2 parts
- 10-13. Percy Pimpernickel—Soubrette, C.....1000
- 10-14. Seed and the Harvest, D.....2000
- 10-16. Si's Wonderful Mineral Spring, C.....1000
- 10-17. From Peril to Peril, D.....1000
- 10-19. The Mad Mountaineer, D.....1800
- 10-20. Hesanut Buys an Auto, Cartoon, 200
- 10-20. A Wise Rube, C.....1000
- 10-21. The False Guardian, D.....1000
- 10-23. Micky Flynn's Escapade, C.....1000
- 10-24. The Demon of the Rails, D.....1000
- 10-26. The Lynbrook Tragedy, Alice Joyce Series, D.....2 parts

- 10-27. The No-Account Count, C.....1000
- 10-28. The Menace of Fate, D.....2 parts
- 10-30. Ham and the Villain Factory, C.....1000
- 10-31. The Vengeance of Winona, D.....1000

KLEINE

- 9-29. A Shot from Ambush, D.....2000
- 10- 6. The Wrecked Special, D.....2000
- 10-13. On the Battle Line, D.....2000

LUBIN

- 10- 6. Wife's Athletic Mamma, C.....400
- 10- 7. The Girl at the Lock, D.....2000
- 10- 8. In Old Virginia, D.....2000
- 10- 9. The Green-Eyed Monster, D.....1000
- 10-10. When the Ham Turned, C.....1000
- 10-12. The Girl from the West, the Beloved Adventure Series No. 5, D.....1000
- 10-13. Swami Sam, D.....400
- 10-14. The Bond of Womanhood, D.....2000
- 10-15. The Imposter, D.....2000
- 10-16. The Long Lane, D.....1000
- 10-17. The Smuggler's Daughter, C.....1000
- 10-19. The Golden Hope, the Beloved Adventurer No. 6, D.....1000

RELEASE DAYS

GENERAL FILM PROGRAM

- Monday—Biograph, Edison, Essanay, Hearst-Selig News Pictorial, Kalem, Pathé, Selig, Vitagraph.
- Tuesday—Edison, Essanay, Geo. Kleine, Pathé, Lubin, Melies, Selig, Vitagraph.
- Wednesday—Edison, Essanay, Kalem, Lubin, Melies, Selig, Pathé, Vitagraph.
- Thursday—Biograph, Essanay, Hearst-Selig News Pictorial, Lubin, Melies, Pathé, Selig, Vitagraph.
- Friday—Edison, Essanay, Kalem, Selig, Pathé, Lubin, Vitagraph.
- Saturday—Biograph, Edison, Essanay, Kalem, Lubin, Pathé, Vitagraph, Selig.

UNIVERSAL PROGRAM

- Monday—Victor, Imp, Powers.
- Tuesday—Gold Seal, Crystal, Nestor.
- Wednesday—Nestor, Joker, Eclair, Animated Weekly.
- Thursday—Imp, Rex, Frontier, Sterling.
- Friday—Nestor, Powers, Victor.
- Saturday—Joker, Frontier, 101 Bison.
- Sunday—Rex, Crystal, Eclair, L-KO.

MUTUAL PROGRAM

- Monday—American, Keystone, Reliance.
- Tuesday—Beauty, Majestic, Thanhouser.
- Wednesday—American, Broncho, Reliance.
- Thursday—Domino, Keystone, Mutual Weekly.
- Friday—Kay-Bee, Majestic, Princess.
- Saturday—Keystone, Reliance, Royal.
- Sunday—Majestic, Komic, Thanhouser.

- 10-20. Such a Mess, C.....400
- 10-21. Only Skin Deep, C.....600
- 10-21. The Hopeless Game, D.....2000
- 10-22. Her Mother Was a Lady, D.....2000
- 10-23. The Girl in the Tenement, D.....1000
- 10-24. The Crooks, C.....1000
- 10-26. "The Holdup," the Adventurer Series, No. 7, D.....1000
- 10-27. Love and Title, C.....400
- 10-28. The Mountain Law, D.....2000
- 10-29. The Wolf's Daughter, D.....2000
- 10-30. Thumb Prints and Diamonds, D.....1000
- 10-31. The Soubrette and the Simp, C.....400
- 10-31. An Interrupted Nap, C.....600

MELIES

- 9-15. The Tramp's Revenge, C.....1000
- 9-17. The Scab Waiter, C.....1000
- 9-22. The \$1,000 Pants, C.....1000
- 9-24. How Clarence Got His, C.....1000
- 9-29. A Circus Romance, C.....900
- 10- 1. Blind Marriage, C.....1000

PATHE

- 8-24. Edible Fishes of the English Channel, E.....550
- Pictureque Normandy, France, T.....500

- 8-25. Rapids and Falls at Trondhjen, T.....300
- Pictureque France, Lower Brittany, T.....350
- From Havre to Buc by Hydro-aeroplane, T.....350
- 8-26. Pathé's Daily News, No. 54, N.....1000
- 8-31. Pathé's Daily News, No. 55, N.....1000
- 9- 2. Pathé's Daily News, No. 56, N.....1000

SELIG

- 10- 7. The Reparation, D.....1000
- 10- 8. Hearst-Selig News Pictorial No. 64, N.....1000
- 10- 9. Jimmie, the Porter, C.....500
- 10-10. Her Victory Eternal, D.....1000
- 10-12. The Dream Girl, D.....2000
- 10-13. Hearst-Selig News Pictorial No. 65, N.....1000
- 10-14. The Mexican, D.....1000
- 10-14. The Mysterious Beauty, C.....1000
- 10-15. Hearst-Selig News Pictorial, No. 66, N.....1000
- 10-16. The Man-Hater, C.....1000
- 10-17. The Woman of It, D.....1000
- 10-19. The Blue Flame, D.....2000
- 10-19. Hearst-Selig News Pictorial No. 67, N.....1000
- 10-20. Jimmy Hayes and Muriel, D.....1000
- 10-21. The Rajah's Vacation, C.....1000
- 10-22. Hearst-Selig News Pictorial No. 68, N.....1000
- 10-23. A Tonsorial Leopard Tamer, C.....1000
- 10-24. The Tragedy That Lived, D.....1000

VITAGRAPH

- 10- 7. Kill or Cure, C.....1000
- 10- 8. The Loan Shark King, D.....1000
- 10- 9. Josie's Legacy, C.....1000
- 10-10. The Rose and the Thorn, D.....2000
- 10-12. Midst Woodland Shadows, Idyl.....1000
- 10-13. Marcea, the Foster-Mother, D.....2000
- 10-14. The Peacemaker, C.....1000
- 10-15. His Dominant Passion, D.....1000
- 10-16. Fatty's Sweetheart, C.....1000
- 10-17. The Girl in the Case, D.....2000
- 10-19. His Wedded Wife, D.....1000
- 10-20. Anne of the Mines, D.....2000
- 10-21. Under False Colors, C.....1000
- 10-22. The Mill of Life, D.....1000
- 10-23. A Custome Piece, C.....1000
- 10-24. Good-bye Summer, D.....2000
- 10-26. The Cave Dwellers, C.....1000
- 10-27. Underneath the Paint, D.....2000
- 10-28. William Henry Jones' Courtship, C.....1000
- 10-29. Kidding the Boss, C.....1000
- 10-30. Bunny Backslides, C.....1000
- 10-31. Within an Ace, D.....2000

UNIVERSAL PROGRAM

ANIMATED WEEKLY

- 10-14. No. 135, N.....
- 10-21. No. 137, N.....
- 10-28. No. 138, N.....

101 BISON

- 10-24. My Lady Raffles in "The Mysterious Hand," D.....3000
- 10-24. My Lady Raffles in "The Mysterious Hand," D.....3000
- 10-31. A Daughter of the Red Skies, D.....2000

CRYSTAL

- 10- 6. Liferitis, C.....
- 10-13. Oh, You Gypsy Girl and Some Collector, C.....
- 10-20. Vivian's Transformation, C.....
- 10-27. Persistent Lovers, C.....1000

ECLAIR

- 10- 7. The Line Rider, D.....2000
- 10-11. Cupid Victor.....1000
- 10-18. The Quarrel, D.....
- 10-24. The Squatter, D.....3000
- 10-21. The Vicar, D.....2000
- 10-25. Smallpox on the Circle U, D.....
- 10-28. The Mystery of Graysom Hall, D.....2000
- 11- 1. At the Crucial Moment, D.....1000

THE 1914 MOTIOGRAPH

Used When the Best is Needed

THE BUYER'S CODE

QUALITY
 ENDURANCE
 STEADY AND
 FLICKERLESS
 PROJECTION

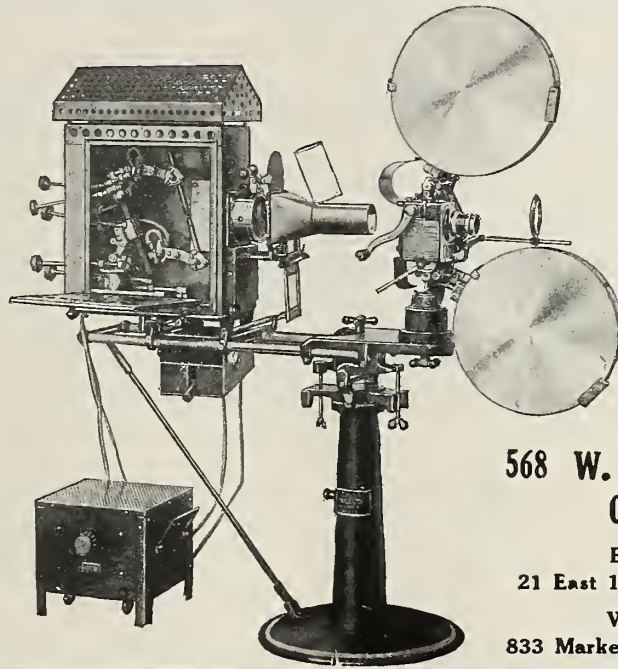

SATISFACTION
 AND
 LOWEST
 UP-KEEP COST

The
**ENTERPRISE
 OPTICAL MFG.
 CO.**

**568 W. RANDOLPH STREET
 CHICAGO, ILL.**

EASTERN OFFICE
 21 East 14th Street, New York, N. Y.

WESTERN OFFICE
 833 Market Street, San Francisco, Cal.

"Flying A" Features

American "Beauty" Features

Presenting **VIVIAN RICH** and **WM. GARWOOD**

Under direction of Sydney Ayres

Release Monday, October 26, 1914

AMERICAN BEAUTY PRODUCTIONS

"A RUDE AWAKENING"

A pleasing and refined Society Comedy, with splendid popular cast
 Release Tuesday, October 27, 1914

"SWEET AND LOW"

A Human Interest Drama—splendidly enacted under direction of Sydney Ayres
 Release Wednesday, October 28, 1914



Distributed exclusively through the United States and Canada by the Mutual Film Corporation.

AMERICAN FILM MANUFACTURING CO.
CHICAGO

RELEASE DATES FOR READY REFERENCE—Continued

FRONTIER

10—4. Four Days, D.....
 10—11. Dolly's Deliverance, D.....
 10—18. In the Hollow of an Oak, D.....
 10—24. The Scarecrow's Secret, D.....
 10—31. The Blacksmith's Daughter, D.....

GOLD SEAL

10—13. The Trey O' Hearts, Episode No. 11, D.....2000
 10—20. Trey o' Hearts, Episode No. 12, D.....2000
 10—27. The Trey o' Hearts, Episode No. 13, D.....2000

IMP

10—1. The Tenth Commandment, D.....3000
 10—5. Shadows, D.....2000
 10—8. Universal Boy in "Rural Adventures," D.....
 10—12. Mary's Convert, Reissue, D.....
 10—15. The Futility of Revenge, D.....2000
 10—19. Country Innocence, D.....2000
 10—22. Universal Boy in "The Gates of Liberty"
 10—26. Marie's Patients, and Educational; split reel
 10—29. In Self-Defense, D.....2000

JOKER

9—30. The New Butler, C.....
 10—3. In the Clutches of the Villain, C.....
 10—7. The Baseball Fan in Fanville, C.....
 10—10. Cruel, Cruel World, C.....
 10—14. On Again, Off Again, Finnigan, C.....
 10—17. Across the Court, C.....
 10—21. The Countless Count, C.....
 10—28. Noads' Adless Day, C.....
 10—31. When Their Wives Joined the Force, C.....

L-KO

10—25. Love and Surgery, C.....2000

NESTOR

9—18. The Troublesome Wink, C.....
 9—23. The Half Breed, D.....
 9—25. Fruits and Flowers, C.....
 9—30. The White Wolf, D.....
 10—2. Out of the Frying Pan, C.....
 10—7. The Old Bell Ringer, D.....
 10—9. He Never Said a Word, C.....
 10—16. The Way of Life, D.....
 10—23. Cupid Pulls a Tooth, and Mt. St. Bernard, Switzerland; split reel.
 10—27. The Wall of Flame, D.....

POWERS

9—25. The Actress, D.....
 10—2. The Actress, D.....
 10—9. The Mayor's Manicure, C.....
 10—16. The Padrone's Ward, D.....2000
 10—23. Suspended Sentence, C.....
 10—30. The Senator's Lady, D.....

REX

9—27. As the Wind Blows, D.....2000
 10—1. The Boob's Legacy.....
 10—4. The Pipes of Pan, D.....2000
 10—8. A Law Unto Herself, D.....2000
 10—11. Virtue Its Own Reward, D.....2000
 10—15. Her Life's Story, D.....
 10—18. Kid Regan's Hands, D.....2000
 10—22. Olaf Erickson—Boss, D.....2000
 10—25. The Little Blond Lady, D.....
 10—29. White Roses, D.....
 11—1. The Vagabond, D.....2000

STERLING

10—15. Heinie's Outing, C.....
 10—19. The Mistaken Bath House, C.....
 10—22. Secret Service Saitz, C.....
 10—26. Snoope's Day Out, C.....1000
 10—29. A Race for a Bride, C.....1000

UNIVERSAL IKE

10—6. The Neglected Wife.....
 10—13. Mary Green's Husband, and Educational, C.....
 10—13. Mary Green's Husband, and The Monkey Cabaret, C., split reel..

VICTOR

10—5. Disillusioned, D.....
 10—9. The Woman Who Won, C.....
 10—12. His Father's Son, D.....2000
 10—16. The Funny Mr. Dingle, C.....
 10—19. Rice Industry in the U. S., E.....
 10—23. The Bride of Marble Head, D.....2000
 10—26. Terrence O'Rourke No. 1, D.....2000
 10—30. The Witch Girl, Mary Fuller, D.....2000

MUTUAL FILM PROGRAM

AMERICAN

9—30. The Brothers.....
 10—5. Daphnia.....
 10—7. Billy's Rival.....
 10—12. Jail Birds, D.....2000
 10—14. The Fisherman's Daughter, D.....1000
 10—19. In the Daylight, D.....2000
 10—21. In the Open, D.....1000
 10—23. The Final Impulse, D.....1000

BEAUTY

9—22. Caught in a Tight Pinch.....
 9—29. The Legend of Black Rock.....
 10—6. Niede, D.....1000
 10—13. Winsome Winnie, C.....1000
 10—20. Dad and the Girls, C.....1000

BRONCHO

10—21. Shorty and Sherlock Holmes.....
 10—28. The Golden Goose.....
 11—4. The Desperado.....2000
 11—11. Destin's Night.....

DOMINO

10—8. The Whiskey Runners.....
 10—15. Jimmy.....
 10—22. The Power of the Angelus.....
 10—29. Eric the Red's Wooing.....
 11—5. In Old Italy.....
 11—12. The Friend.....2000
 11—19. Nipped.....2000

KAY-BEE

10—2. One of the Discard.....
 10—9. The Sheriff of Muscatine.....2000
 10—16. The Word of His People.....2000
 10—23. The Spark Eternal.....2000
 10—30. The Worth of a Life.....
 11—6. The Game of Life.....2000

KEYSTONE

9—3. The Baggage Smasher.....
 9—5. A Brand New Hero.....
 9—7. The Rounders.....
 9—10. Mabel's Latest Prank.....
 9—12. Mabel's Blunder, C.....
 9—14. All at Sea, C.....
 9—17. Bombs and Bangs, C.....
 9—19. Lover's Luck, C.....
 9—21. He Loved the Ladies, C.....1000
 9—24. The New Janitor, C.....1000
 9—28. Hard Cider, C.....1000
 10—1. Killing Horace, C.....1000
 10—3. Fatty Again, C.....1000
 10—5. Their Ups and Downs, C.....1000
 10—8. Hello Mabel, C.....1000
 10—10. Those Love Pangs, C.....1000
 10—12. Anglers, C.....1000
 10—15. High Spots on Broadway, C.....1000
 10—19. Dash, Love and Splash, and Santa Catalina Islands, split reel.....
 10—22. Love Siege, C.....1000
 10—24. Stout Heart but Weak Knees, C.....1000
 10—26. Shot in the Excitement, C.....1000
 10—26. Dough and Dynamite, C.....2000

KOMIC

9—20. Foiled Again.....
 9—27. Bill Manages a Prize-Fighter (No. 7)
 10—4. The Million Dollar Bride.....
 10—11. Bill Spots a Vacation, (No. 8), C.....
 10—18. Dizzy Joe's Career.....
 10—25. Bill Joins the W. W. W.'s No. 9..

MAJESTIC

9—27. The Great God Fear.....
 9—29. A Mother's Trust.....
 10—4. Out of the Air.....
 10—6. The Unpainted Portrait.....
 10—11. The Sands of Fate, D.....2000
 10—13. The Warning.....
 10—16. Back to the Kitchen.....
 10—18. For Her Father's Sins.....2000
 10—20. Environment.....
 10—25. Paid with Interest.....2000
 10—27. A Mother's Influence.....
 11—1. Paid with Interest.....
 11—3. False Pride.....

MUTUAL WEEKLY

9—3. No. 88.....
 9—10. No. 89.....
 10—17. No. 90.....
 10—24. No. 91.....
 11—1. No. 92.....
 11—8. No. 93.....
 11—15. No. 94.....
 11—22. No. 95.....

PRINCESS

9—11. Sis.....
 9—18. The Master Hand.....
 9—25. The Balance of Power.....
 10—2. The Balance of Power.....
 10—9. The One Who Cared, D.....
 10—16. The Touch of a Little Hand.....
 10—23. The Face at the Window.....

RELIANCE

10—5. Our Mutual Girl, No. 38.....
 10—7. The Badge of Office.....
 10—10. The Tardy Canon Ball.....2000
 10—12. Our Mutual Girl (No. 39).....
 10—14. Bad Man Mason.....
 10—17. The Revenue Officer's Deputy.....2000
 10—19. Our Mutual Girl (40).....
 10—21. Out of the Deputy's Hands.....
 10—24. A Blotted Page.....2000
 10—26. Our Mutual Girl No. 41.....
 10—30. The Availing Prayer.....
 10—31. The Wrong Prescription.....
 11—2. Our Mutual Girl No. 42.....
 11—4. The Miner's Peril.....
 11—7. A Woman Scorned.....
 11—9. Our Mutual Girl No. 43.....
 11—14. The Floating Call.....

ROYAL

10—10. The Pet of the Petticoats.....
 10—17. The Black Hand.....
 10—24. Harold's Toupee.....
 10—31. Phil's Vacation.....
 11—7. Max's Money.....
 11—14. A Fortune in Pants.....

THANHOUSER

9—20. The Mettle of a Man.....
 9—22. The Varsity Race.....
 9—27. The Harvest of Regrets.....
 9—29. The Trail of the Love Lorn.....
 10—4. A Dog's Love.....
 10—6. The Cripple.....
 10—9. The Benevolence of Conductor 786
 10—11. The Rescue.....
 10—13. The Diamond of Disaster.....2000
 10—18. Left in the Train.....
 10—20. Old Jackson's Girl.....2000
 10—25. Mr. Cinderella.....
 10—27. A Madonna of the Poor.....2000
 11—1. Shep's Race with Death.....
 11—3. The Turning of the Road.....
 11—8. Keeping a Husband.....
 11—10. The Terror of Anger.....
 11—13. The Chasin.....
 11—15. The Man with the Hoe.....

LUBIN

THE PRODUCER OF MASTERPIECES
EVERY EXHIBITOR SHOULD BOOK THESE EXCEPTIONAL FEATURES
 (Through the General Film Special Service)

WILLIAM ELLIOTT, Late Star of "Madame X"
 Company

in
"THE FORTUNE HUNTER"
 6 Reel Comedy By Winchell Smith Produced by Barry O'Neil

"MARAHA, THE PYTHONESS"
 3 Reel Drama By Clay M. Greene Prod. by Joseph W. Smiley

"THE WEIGHT OF A CROWN"
 3 Reel Drama By M. B. Havey Produced by Harry Myers

READY FOR EARLY RELEASE
 By Arrangement with Fred Mace
EVELYN NESBIT THAW
 and her son, **RUSSELL WILLIAM THAW**, in
"THREADS OF DESTINY"
 5 Reel Drama By Wm. H. Clifford Prod. by Joseph W. Smiley

EDWIN ARDEN

in
 5 Reel Drama **"EAGLE'S NEST"** Produced by
 By Edwin Arden Romaine Fielding

RAYMOND HITCHCOCK In a 5 Reel Comedy Drama
 by Lawrence McCloskey
 Produced by George Terwilliger

"STONEWALL JACKSON'S WAY"
 3 Reel Drama By Emmett Campbell Hall Prod. by Edgar Jones

IN PREPARATION
ROSE COGHLAN
 And **ETHEL CLAYTON** in
"THE SPORTING DUCHESS"
 6 Reel Comedy Drama By Cecil Raleigh Prod. by Barry O'Neil

SIX REGULAR RELEASES EACH WEEK

"THE BELOVED ADVENTURER"—Sixth of Series, "The Golden Hope"—Drama	Monday,	October 19th
"SUCH A MESS" (Split Reel Comedies)	Tuesday,	October 20th
"ONLY SKIN DEEP"—Two Reel Drama	Wednesday,	October 21st
"THE HOPELESS GAME"—Two Reel Drama	Thursday,	October 22nd
"HER MOTHER WAS A LADY"—Two Reel Drama	Friday,	October 23rd
"THE GIRL IN THE TENEMENT"—Drama	Saturday,	October 24th
"THE CROOKS"—Comedy		

SPECIAL ONE, THREE AND SIX SHEET POSTERS.

Lubin Manufacturing Company, Philadelphia, Pa.

Chicago Office:
 154 West Lake Street



No matter how thrilling a story one may read, interest is not sustained if poor type, poor paper and poor press work make hard work for the eyes. It's the same with motion pictures. A clear picture is as necessary as a good scenario.

Because the basic product is right, the clearest pictures are on "Eastman" film. Look for the stencil mark in the margin.

EASTMAN KODAK CO.,
 ROCHESTER, N. Y.

TITLES

Our *Title Department* has been re-organized, elaborately equipped and placed under the direction of recognized experts.

Its highly perfected apparatus, lino-type machine and job presses enable us to produce the most difficult title work in any language—artistically, accurately and *quickly*—and at *lower prices* than have ever yet been quoted.

DEVELOPING AND PRINTING

Save money and insure the best results by entrusting your work to the *largest and most complete commercial plant in America.*

CENTAUR FILM CO.

Bayonne, N. J., and 1600 Broadway, N. Y.

RELEASE DATES FOR READY REFERENCE—Continued

FEATURE RELEASES

ALCO FILM CORPORATION

ALL STAR

10— 5. The Nightingale, D.....5 parts
10—19. The Shore Acres.....

CALIFORNIA MOTION PICTURE CORP.

11— 2. Salomy Jane5 parts

FAVORITE PLAYERS

10—19. The Key to Yesterday, D.....4 parts

POPULAR PLAYS AND PLAYERS

10—12. The Ragged Earl, D.....
10—26. Michael Strogoff, D.....5 parts

APEX

Sept. Queen of the Counterfeiters, D..4 parts
Oct. Called to the Front; or Europe at War, D.....3 parts

BOX OFFICE ATTRACTIONS

9—21. Will o' the Wisp, D.....4 parts
9—28. Fighting the World, D.....5 parts
9—28. The Square Triangle, D.....3 parts

COSMOS FEATURE FILM CORPORATION

10—15. Lena Rivers, D.....

COSMOFOTOFILM CORPORATION

Aug. What a Woman Will Do, D.....4 parts
Sept. England's Menace, D.....3 parts
Oct. England Expects—, D.....

HEPWORTH-AMERICAN

Aug. The Girl from the Sky, C.....
8—29. The Chimes, D.....3 parts
The Terror of the Air, D.....2 parts
Sept. Creatures of Clay, D.....3 parts

HECTOR FILM CORPORATION

Sept. Born Again, D.....5 parts

GEORGE KLEINE

Sept. Spartacus, D.....8 parts
Sept. Vendetta, D.....5 parts
Sept. The Lion of Venice, D.....6 parts

LIFE PHOTO FILM CORPORATION

Sept. Captain Swift, D.....5 parts
Oct. The Ordeal, D.....5 parts

ECLECTIC FILM COMPANY

Max Has the Boxing Fever, C... 560
Picturesque Lake Dahl, British India, Scenic 400
In Soak, C.....
A Prince of India, D.....
Pathé Daily News No. 64-1914, Top.
Second Door Left, C.....
Pathé Daily News No. 65, Top....
Perils of Pauline, No. 14, D.....
Colonel Heeza Liar in the Wilderness, C..... 700
Strange Animals, E..... 300
Pathé Daily News No. 62-1914, Top.
The Colonel's Wife, D.....
Pathé Daily News No. 63-1914, Top.
War Stricken Louvain, Topical....

PARAMOUNT PICTURES

BOSWORTH

10— 1. Pursuit of the Phantom.....5 parts
10—19. Hypocrites!4 parts
11—23. Chechako4 parts

FAMOUS PLAYERS

10—26. The County Chairman5 parts
10—29. His Last Dollar.....4 parts
11— 2. Behind the Scenes.....5 parts
11— 9. Man from Mexico.....5 parts
11—30. Mrs. Black Is Back.....

JESSE LASKY COMPANY

10—22. Where the Trail Divides.....5 parts
11—16. The Rose of the Rancho.....5 parts
11—26. The Man from Home.....5 parts

PLAYGOERS FILM COMPANY

Oct. The Great Diamond Robbery, D..6 parts

PICTURE PLAYHOUSE FILM COMPANY, INC.

8—10. The Oath of a Viking.....3000
8—19. The Next in Command.....4000
8—26. The Film Detective.....4000
9— 5. The Mystery of the Poison Pool, D.....5 parts
9—10. Desperado of Panama, D.....3 parts
9—17. Lure of the Yukon, D.....3 parts

RENOWNED PLAYERS

Sept. A Great Mistake, D.....5 parts

SAWYER, INCORPORATED

Sept. Tyranny of the Mad Czar, D.....4 parts
Sept. Doc, D.....4 parts
Oct. Thirty Minutes in Melodrama, C..2 parts
Oct. The Factory Magdalen, D.....4 parts
Oct. The Volunteer Parson, D.....4 parts
Oct. The Detective Queen, D.....4 parts

WARNER'S FEATURES

Sept. When We Were Young, D.....
Sept. The Arrow's Tongue, D.....
Sept. Alone in New York, D.....5 parts
Sept. The Price of Crime, D.....3 parts
Oct. Hunted Down, D.....
Oct. In the Duke's Power, D.....
Oct. Bess of the Blazing Sea, D.....
Oct. The Adventures of Kitty Cobb, D.....

WORLD FILM CORPORATION

9—14. Protea II, D.....5 parts
9—21. The Dollar Mark, D.....5 parts
9—28. Mother, D.....4 parts
The Man in the Cellar, D.....

ANIMATED SONGS

Imperial Motion Picture Co., New York
Latest Releases:

A Fool There Was.
Take Me Back to Frisco Town.
Shadows.
Father Came Home with the Milkman in the Morning.
Dear Old Girl.
What a Wonderful Love That Would Be.
When I Dream of Killarney.
Down in Our Old Country Town.
In the Valley of the Moon.
Let's Go Back to Sweetheart Days.
Just a Black Sheep That Strayed from the Fold.
Let Us Kiss and Make Up Again.
There's a Lonesome Little Girl in a Lonesome Little Town.
She Was My Dad's First Sweetheart.
Down Where the Old Road Turns.
Push It Along.
She's Just a Bird in a Gilded Cage.

BOX OFFICE OPENS 13 BRANCH EXCHANGES

Four companies are engaged on the pretentious productions scheduled for The Box Office Attraction Company's program. These productions are adaptations from well-known novels and plays. It is the intention of the organization to release three features a week and three elaborate features a month with single reel comedies to fill in.

Offices in all the large cities have been opened as follows:

Cleveland, Boston, Syracuse, Philadelphia, Pittsburgh, St. Louis, Kansas City, Dallas, San Francisco, Denver, Minneapolis, Chicago and Seattle.

Eleven more branches are now in the process of organization. The twelve that are now in full operation are managed by experts who have a thorough knowledge of local conditions.

KIRKWOOD ELECTED SCREEN CLUB PRESIDENT

James Kirkwood was elected president of the Screen Club at the annual election held Saturday, October 3, by a vote nearly two and a half times larger than that of his closest competitor. The entire ticket advocated by Mr. Kirkwood's supporters was also elected, with the exception of the second vice-president. "Doc" Willat won out for this place over Adolph Zukor, the candidate on the Kirkwood ballot.

The total number of votes cast was 226. Of these Mr. Kirkwood received 127, "Joe" Farnham 53, and Mr. "Billy" Quirk 46. The votes for the other officers were distributed in about the same proportion.

Those elected were: Ben Wilson, vice-president; "Doc" Willat, second vice-president; Charles Bauman, third

vice-president; George Blaisdell, treasurer; William Barry, corresponding secretary, and Paul Scardon, recording secretary. The board of governors elected is made up of King Baggot, Jake Gerhardt, Jules Berstein and Frank Powell.

The election followed a spirited campaign which had been carried on for some time. Those members who wanted to see the club president drawn from the ranks of the business men in the film industry, rather than from the actors, advocated the election of a ticket headed by Joseph Farnham.

Billy Quirk, of the Vitagraph company, headed another ticket which asked for the actor vote, as did Mr. Kirkwood's. All of the candidates published "campaign literature," and in other ways worked hard to present their cause.



The AVENGING CONSCIENCE

OR
Thou Shalt Not Kill

A SIX REEL — *SPECIAL FEATURE*



EMBODYING ALL THE SUSPENSE,
ACTION AND DRAMATIC CLIMAXES
THAT EDGAR ALLEN POE IS
NOTED FOR AND DIRECTED BY
THE GREATEST DIRECTOR OF
MODERN TIMES

D.W. GRIFFITH'S
GREATEST FEATURE FILM

“THE ESCAPE”

IN SEVEN STARTLING REELS

FOUNDED ON THE PLAY BY PAUL
ARMSTRONG OF THAT NAME.



“THE ESCAPE” IS A LESSON, A MODERN
LESSON SHOWING THE ESCAPE OF A
WOMAN FROM POVERTY, DEGRADATION
AND SIN TO A BETTER LIFE

ARRANGE BOOKINGS NOW THROUGH

CONTINENTAL FEATURE FILM CORP.

29 UNION SQUARE

OR

WESTERN IMPORT COMPANY

71 WEST 23RD STREET

NEW YORK, N.Y.



It's Not the Inside

of your theatre that will draw the crowds to the box-office. The magnet is the lobby.

The man or woman who wants to see a motion picture show is going to judge the quality of the theatre, its respectability, its performance and the class of people with whom they will sit by what you have in your lobby.

Posters cannot possibly accomplish all this. Photographs can.

Everybody is a judge of photographs and the pictures of stars furnished by the Wyanoak Publishing Company have stood every inspection and have helped tremendously to

PACK THEATRES.

An evidence of the quality of Wyanoak photographs is that we have been granted by contract the exclusive right to produce photographs of actors and actresses for the General Film Company and the Universal Film Manufacturing Company. These two concerns know where to get the best.

11 x 14, Suitable for framing (Sepia), \$1.50 per doz.

22 x 28, Suitable for framing (Sepia), 40c. each.

22 x 28, Suitable for framing, Hand Colored, \$1.00 each.

A postcard request will bring complete information about our coupon plan. It's a business builder.

Order from your exchange or

Wyanoak Publishing Co.

136-146 West 52d Street

NEW YORK, N. Y.

MORRISON AND POPPE LAUNCH NEW FIRM

THE latest along Broadway is the formation of a company composed of two men young in years but old in the motion picture game. Ed. Morrison and Harry Poppe, as they are known to the trade, compose the new organization which has made its abode in the Times Building, Times Square, New York.

Mr. Poppe hails from Cincinnati, where he began his career as press representative for Heuck & Fennessey, owners and managers of the Lyric Theatre and Heuck's Opera House in Cincinnati, and other houses in Indianapolis and the West.

He next accepted a position in the Cincinnati office of the "Billboard," where he grew to be associate editor, and was later made manager of the vaudeville, music and burlesque departments in that company's New York office. After four years with this paper he left to manage "The Goose Girl" for Baker and Castle.

From this position Mr. Poppe's rise in the amusement business was sure and rapid. He held positions as advance agent and press man for Arthur Nikisch and his London Orchestra and other important attractions. He became associated with his present partner, Mr. Morrison, while on the "Billboard," where the two men worked side by side for many years.

Mr. Morrison needs no introduction to the motion picture trade. He conducted the motion picture department of the "Billboard" for three years and was then made manager of that paper's Chicago office. This position he left to work under Adolph Eisner, then manager of the Mutual Exchange in Chicago. Mr. Morrison has also managed exchanges in New York State. He recently formed a company of his own which forms the nucleus of the present company which has been organized and has developed a new project.

The plan of the new project has not been disclosed, but it looks like a big one and a going proposition. The company's first advertisement appears in the rear advertising section of this issue opposite the inside back cover.

LIONEL BARRYMORE JOINS KINETOPHOTE

An interesting piece of news has come from the offices of the Kinetophote Corporation at 126 West 46th street, New York, in the statement made to THE NEWS that a large company is filming "The Span of Life" for that company with Lionel Barrymore in the role of Richard Blunt.

The scenario was written by Catherine Carr from the late Sutton Vane's famous old drama of the same name. The World's rights to the work as a picture play were recently bought by the Kinetophote from the Blunt estate.

Associated with Mr. Barrymore in the piece are Gladys Wynne, former leading woman with George Arliss, and Lyster Chambers. The picture is being staged under the direction of Edward Mackay. When the film is finished it will be booked exclusively through the Montgomery - Simmons Film Service, Inc., which has offices at 126 West 46th street. Elaborate settings are now in preparation for the play.



LIONEL BARRYMORE

"Michael Strogoff" Is Third Alco Release

Ready October 19—Barrymore Signs for Two More Features, Following Success of "The Nightingale"—"Ragged Earl" Going Big

BIG and constant appeal to the eye of the spectator is made by the third Alco release, "Michael Strogoff," produced by the Popular Plays and Players Company, with the noted tragedian, Jacob P. Adler, in the title role. "Michael Strogoff" is in five reels with

demanding more film dramas with the talented Miss Barrymore. In response to this demand, the All Star Feature Corporation has concluded successfully negotiations with Miss Barrymore for two more pictures, which of course are to be released through Alco. Augustus Thomas begins work upon the first of the two new scenarios at once.



JACOB P. ADLER IN A SCENE FROM "MICHAEL STROGOFF" (Popular Plays and Players—Alco)

249 scenes. The burning of Moscow, the escape of refugees down the river of fire on a raft, and the apparent blinding of Strogoff, the messenger of the Czar, are a few of the thrilling incidents of this drama of the War of the Tartars. This drama of Russia is released on October 19. The film was favorably reviewed in the MOTION PICTURE NEWS of June 20.

The Alco current release, Andrew Mack in "The Ragged Earl," has already taken a firm hold on the affections of exhibitors and spectators alike. The story of how two young people were to be forced to marry for wealth, and of how The Ragged Earl and Kathleen finally frustrated all such designs and were married, despite their poverty, is one dear to the hearts of all who believe in love and a cottage.

The first day "The Ragged Earl" was shown in the William Fox's Nemo Theatre, 110th street and Broadway, it had been planned to present the lovable drama of Irish character but once during a performance. Vaudeville was to follow. But the management received so many telephone calls demanding "The Ragged Earl" that vaudeville was cut out at the evening performance and the Mack comedy run twice.

The first Alco release, Ethel Barrymore in "The Nightingale," has proved such a drawing card that exhibitors are

GENERAL DROPS VON RONKLE IN CHICAGO

Special to MOTION PICTURE NEWS

Chicago, Oct. 14.

Percy Waters, of the General Film Company, dropped into Chicago last week, and after he left the Windy City the map of the general film company exchanges here was changed. I. Van Ronkle, who for the past year or so has been branch manager, was let out, and this title was added to Mr. Willis', who is already special representative in this territory.

George Berg, who for a long time has been connected with the Chicago branches of the organization, was made manager of the branch which was formerly presided over by Mr. Von Ronkle.

HEARST-SELIG BRUSSELS FILMS FIRST IN FIELD

The attention of exhibitors is called particularly to the Hearst-Selig News Pictorial Reel No. 61, released on Monday, September 28.

This reel presented some 400 feet of the first pictures made of the German army since the European war commenced. The scenes shown were those of the German occupancy of Brussels. The first pictures of the Germans in Brussels were shown in the Hearst-Selig News Pictorial. Since that time many film companies have been advertising "First Pictures of the Germans in Brussels."

HUDSON VISITS OLD STAMPING GROUND

Special to MOTION PICTURE NEWS

Los Angeles, Oct. 13.

Frank Hudson, district manager of the Eclectic Film Company, with office at San Francisco, spent a week recently in Los Angeles with Manager B. E. Loper, of the local exchange.

Mr. Hudson was formerly connected with local film exchanges, and he was greeted by his many friends here. The local Eclectic exchange, established less than six months ago, is in a very thriving condition and enjoying a very liberal patronage.

Dallas Store Devotes Window to "Kitty Cobb"

Tiche-Goettinger Makes an Elaborate Display of Flagg Book and Lithographs With List of Theatres Showing Warner Film

WORD has just been received from H. E. Stahler, manager of the Dallas, Texas, exchange of Warner's Features, Inc., of a co-operative advertising plan.

Mr. Stahler has booked "The Adventures of Kitty Cobb" very extensively in the Dallas territory. During the time that the film was shown there, the big department store of Tiche-Goettinger had an elaborate window display of James Montgomery Flagg's famous book.

The window was decorated with the beautiful Kitty Cobb lithographs in

seven colors and also with photographs. A card gave the names and addresses of the motion picture theatres where this big four-part feature was on display.

The theatres co-operated by displaying slides stating that a special sale of the book telling the story of Kitty Cobb in picture and text was held by the department store.

Mr. Stahler reports that Kitty Cobb has already made a hit in the Southwest and that it promises to become one of the most popular features ever shown there.

FOLLOWING FLAGG'S FLIGHTS OF FANCY IN A PHOTO PLAY



TWO SCENES THAT SHOW HOW THE WARNER "ADVENTURES OF KITTY COBB" TALLIES WITH ITS FAMOUS ORIGINAL

ALLIANCE PROGRAM

BANG!

The opening gun of the Alliance
Carlyle Blackwell in "The
the public has

THE EUROPEAN ARMIES

entered the fray with the best ammunition they could procure, and supremacy will reward the countries exercising the best judgment in this direction.

Irresistible Solid Shot

"THE PATH FORBIDDEN"

Released Oct. 19, with Octavia Handworth in the leading role. This picture will stamp the Excelsior Feature Film Co. as masters in the art of motography. Miss Handworth plays the dual part of the twin sisters in John B. Hymer's well known book, and the clever double-exposure scenes and marvelous trick work should convince any exhibitor of the strength of the organization, and its ability to film any subject in a superior manner. (Five Reels.)

McVEAGH OF THE SOUTH SEAS

Released Nov. 2 by the Progressive Motion Picture Co. From the book by H. D. Carey, in five reels. A story of daring and action, replete with exciting situations. Beautiful island and ocean scenery.

The Exchanges handling the ALLIANCE PROGRAM
lication of complete list, exhibitors desiring service can have
their territory by



ALLIANCE FILMS CORPORATION

BANG!

Program was fired on Oct. 12, with
"Key to Yesterday," and
capitulated

THE THEATRE OWNER

should fortify his house with a steady supply of feature subjects, and the ALLIANCE PROGRAM provides the most dependable source to secure such subjects.

for High Class Theatres

"AT THE OLD CROSS ROADS"

Released Oct. 26 by the Select Photo-Play Producing Co. in five reels. For fourteen consecutive years the public flocked to see the play. The film version, with its pictured details of tense scenes, should prove more popular than the play as put out by Arthur C. Aiston. Estha Williams, the star in the original play, interprets the leading part of Parepa. A film with action in every foot, and suspense in every reel.

COMING PRODUCTIONS

THE MAN WHO COULD NOT LOSE, from the book by Richard Harding Davis.

THE SHADOW, from the book by John B. Hymer.

AN UNFINISHED STORY, from the book by Richard Harding Davis.

include the most reliable renters in America. Pending publication the name of the exchange which will have the rights to writing or wiring us.

LEAVITT BLDG. 126 W. 46th St., N. Y. City
11th FLOOR



KAY-BEE

K
E
Y
S
T
O
N
E

B
R
O
N
C
H
O

KAY-BEE

One Two-Part Photoplay a Week

Friday, Oct. 23—The Spark Eternal.
Friday, Oct. 30—The Worth of a Life.
Friday, Nov. 6—The Game of Life.

KEYSTONE

Three a Week

Monday, Oct. 19—Dash, Love and Splash and Santa Catalina Islands.
Thursday, Oct. 22—The Love Thief.
Saturday, Oct. 24—Stout Heart, but Weak Knees.
Monday, Oct. 26—Shot in the Excitement.
EXTRA TWO-REEL RELEASES
Monday, Oct. 26—Dough and Dynamite.
Monday, Nov. 9—His Trysting Place.
Monday, Nov. 23—The Sea Nymphs.

BRONCHO

One Two-Part Photoplay a Week

Wednesday, Oct. 21—Shorty and Sherlock Holmes.
Wednesday, Oct. 28—The Golden Goose.
Wednesday, Nov. 4—The Desperado.

DOMINO

One Two-Part Photoplay a Week

Thursday, Oct. 22—The Power of the Angelus.
Thursday, Oct. 29—Eric the Red's Wooing.
Thursday, Nov. 5—In Old Italy.

Released Exclusively Through the
Mutual Film Corporation

PENNANTS—Beautiful bright colored pennants of the four brands can be had by sending to the PUBLICITY DEPT. 35 cents for one, \$1.25 for set of four.

PHOTOS—8 x 10 photos of our players can be had by sending to the PUBLICITY DEPT. 15 cents for one, 50 cents for set of four, \$1.00 for set of eight.

Keystone Mabel in Four Poses 50 Cents

New York Motion Picture Corporation

FORTY-SECOND STREET and BROADWAY, Longacre Building, NEW YORK

DOMINO

KEYSTONE COMEDY

“Dough and Dynamite”

TWO PARTS

Released Monday, October 26th

The first of the two reel Keystones which will be released in addition to the regular releases

A Screaming Comedy, featuring the inimitable

Chas. Chaplin

Produced under the personal direction of

Mack Sennett



The second multiple reel Keystone will be

His Trysting Place featuring **Keystone Mabel**

and

Chas. Chaplin

Release date Monday, November 23rd.

The third two reel comedy will be **The Sea Nymphs**, featuring **Keystone Mabel** and **Fatty**. Release Date Monday, November 9th.

Released Exclusively through the Mutual Film Corporation

KEYSTONE FILM CO.

Longacre Bldg., 42nd St. and B'way, New York



MR. ARTHUR LESLIE,
Motion Picture Newspaper Syndicate,
1505 Broadway, New York, N. Y.

August 21st, 1914.

Dear Leslie:—

Whenever there is an opportunity for real enterprise—chuckful of brightness, originality and broad helpfulness—always one man can be relied upon to leap into the foreground and that is Arthur Leslie.

This is true of the motion picture field and it has been of every other work you have been engaged in.

Thank you most sincerely for your remarkable exhibit of results from your advertisement in the "News," proving it beyond any doubt to be the publication that "reaches the exhibitors." It shows in one flash what I am trying hard to prove with many arguments.

You may be sure that I deeply appreciate your friendliness—as I always have your cleverness.

With best wishes, I am

Very truly yours,

WILLIAM A. JOHNSTON,

President.

WAJ/L.

Imported Carbons For Sale

We Have in Stock a limited quantity of the following brands and sizes of Imported Carbons, which are offered subject to previous sale, as listed below:

Electra Carbons, Cored.... $\frac{3}{8}$ x 12"	\$10.85 per 100	BIO Carbons, Cored..... $\frac{3}{8}$ x 12"	\$14.00 per 100
Electra Carbons, Cored.... $\frac{3}{8}$ x 9 $\frac{1}{2}$ "	8.25 per 100	BIO Carbons, Cored..... $\frac{3}{8}$ x 10"	10.25 per 100
Electra Carbons, Cored.... $\frac{3}{8}$ x 4"	3.60 per 100	BIO Carbons, Cored..... $\frac{3}{8}$ x 10"	8.60 per 100
Etna Carbon, Cored..... $\frac{3}{8}$ x 12"	7.50 per 100	BIO Carbons, Cored..... $\frac{3}{8}$ x 7 $\frac{1}{2}$ "	6.75 per 100
Sirius Carbon, Cored..... $\frac{3}{8}$ x 6"	3.00 per 100	BIO Carbons, Solid..... $\frac{1}{2}$ x 4"	2.50 per 100
Sirius C. C., Solid..... 7-16 x 7"	2.65 per 100	Siemen's "E," Cored..... $\frac{1}{2}$ x 12"	5.75 per 100
		Siemen's "E," Solid..... $\frac{1}{2}$ x 12"	5.50 per 100

Terms: We will not sell less than 100 or more than 1000 carbons to any one customer. The above prices are net F. O. B. New York. All orders must be accompanied by New York draft, Post Office or Express Money Order, covering at least 25% of the amount of the order; balance C. O. D. We will allow a cash discount of 2% only when cash in full is sent with order.

Send Your Order Today: This Advertisement Will Not Appear Again.

We are manufacturers of all kinds and sizes of Poster Frames, Glass Box Office Display Signs, and the Patented Indestructible Brass Slides.

"Anything and Everything For The Theatre"

BEHREND MOTION PICTURE SUPPLY HOUSE

"The House of Prompt Delivery"

Main Office
440 Fourth Avenue.

NEW YORK CITY

Branch
71 West 23d Street.

A NEW FILM SERVICE IN THE FIELD

THE Montgomery-Simmons Film Service, Inc., began operations this week in new quarters in the offices of the Kinetophote Corporation at 126 West Forty-sixth street, New York, where the service will be the exclusive booking agent of all the feature films put out by the Kinetophote.

Both members of the firm are well known to the moving picture trade, especially in the way of booking films and exhibiting them. George N. Montgomery was identified with the exchange and exhibiting ends of the business for a long time in the South and knows that field thoroughly. Ira H. Simmons was booking manager of the World Film Corporation and of the Shubert Feature Film Company before forming his partnership with Mr. Montgomery. Mr. Simmons has had a wide experience among exhibitors all over the country having traveled extensively in the interests of various amusement enterprises in the past. Marcus A. Miller is active as vice-president of the company and Saul G. Lippman is in charge of the New York exchange.

Just now the Montgomery-Simmons Service is pushing "Markia" or "The Destruction of Carthage," an Italian masterpiece which is being exploited by the Kinetophote Corporation, in addition to several other big features among which are "The Linc-Up" for New York State, featuring Commissioner George S. Dougherty, New York's famous police detective. "Forgiven; or, the Jack o' Diamonds," a picture play built on the famous old drama of the same name and featuring Edwin Frosberg who starred in the stage production of the piece for which Montgomery-Simmons has the New York, Pennsylvania and Virginia rights, and "The Spirit of the Poppy," a psychological study of the effects of the drug habit. There are eighteen big film stories in the vaults of the concern which are to be released this winter.

These eighteen film dramas cover a wide range of subjects, and the variety will appeal to every photoplay patron in the country. Comedy, melodrama, tragedy, farce, all kinds of theatrical entertainment, are represented in the repertoire of the Montgomery-Simmons company.





S. E. SHERMAN,
known throughout New England as
the pioneer in the motion picture
business in this territory.

I have purchased the New England rights for

THE YEAR'S GREATEST SUCCESS

Kelcey ^{AND} Shannon

AFTER THE BALL

(AFTER CHAS. K. HARRIS' FAMOUS SONG HIT)

The famous Photo-Drama production proclaimed by un-
solicited letters from managers everywhere to be the artistic
triumph and the biggest house-packer and money-maker of
the year.

SHERMAN STAR FEATURE FILM CO.

Address inquiries now to

S. E. SHERMAN, Hotel Hollis, Tremont Street, Boston, Mass.

MONTGOMERY-
S I M M O N S
F I L M
S E R V I C E
INC.

Telephone: 6072 Bryant

The Spectacle of
the Season

Booking Exclusively
Entire Product of the
**KINETOPHOTE
CORPORATION**
OF NEW YORK

READY NOW

"MARKIA"

IN 5 PARTS

A STORY OF LOVE AMID THE CLASH OF BARBARIC WARFARE

"THE SPIRIT OF THE POPPY"

EDWIN MACKEY AND BROADWAY CAST
IN 6 PARTS

COMING

"THE SPAN OF LIFE"

With Lionel
Barrymore and
Gladys Wynne

MONTGOMERY-
S I M M O N S
F I L M
S E R V I C E
INC.

The Old
Favorite of
Dramatic Stage

NOW BOOKING
In New York State:
"THE LINE-UP"
Featuring Commissioner Dougherty
In New York, Penna. and Virginia:
"FORGIVEN"
or "The Jack O'Diamonds"
Featuring Edwin Forsberg

MONTGOMERY-
S I M M O N S
F I L M
S E R V I C E
INC.

LIST OF DISTRIBUTING EXCHANGES TO BE ANNOUNCED LATER

Be sure to mention "MOTION PICTURE NEWS" when writing to advertisers.



Cosmofotofilm Co



"WHERE THE REAL FEATURES COME FROM"

For some time we have used the Slogan:

"Where the Real Features Come From"

To prove that this is
no mere idle boast

We point with pride to the fact that in the few months we have been operating

THE MILLION DOLLAR STRAND THEATRE,

(The World's Finest Moving Picture House)
has booked FIVE of our subjects:

- "THE HOUSE OF TEMPERLEY"By Sir Arthur Conan Doyle
- "THE BOSUN'S MATE"By W. W. Jacobs
- "ENGLAND'S MENACE"By Bannister Merwin
- "LAWYER QUINCE"By W. W. Jacobs
- "ENGLAND EXPECTS——"By George Loane Tucker

All the product of the famous
LONDON FILM COMPANY

"ENGLAND EXPECTS——"

—Our beautiful and timely two-reel story of 1914—
Will be shown at the "STRAND" the week of October 18th

STATE RIGHTS SELLING RAPIDLY!

Telegraph at our expense if you wish to secure this
EXTRAORDINARILY FINE SUBJECT
for your territory.

"If it is good enough for the STRAND, it ought to be good enough for YOU!"

COMING RELEASES

- "THE THIRD STRING"—featuring Jane Gail, Frank Stanmore and Chas. Rock
 - "BEAUTY AND THE BARGE"—featuring Cyril Maude and Lillian Logan.
- (These two subjects to be released through the Paramount Pictures Corp'n.)

- "SHE STOOPS TO CONQUER"—"The Comedy which has become a Classic"
- "CALLED BACK"—Hugh Conway's great novel and drama.
- "BOOTLES BABY"—John Strange Winter's great military novel.
(Produced in FOUR Parts under an exclusive arrangement with the
Owners of the Work.)

—And many others—Watch for our announcements!

Address

Cosmofotofilm Co



World's Tower Building, 110-112 W. 40th St., New York



OVER 8,000 MIRROROIDE SCREENS IN USE

MR. EXHIBITOR: Your Success Depends, Not Upon Promises, but Upon Actual Results Obtained
Some Screen Manufacturers Will Promise You Everything and Anything, BUT—Will They Guaranteed to Keep Their Promises?

Will they guarantee their screen for five years against cracking, peeling, deteriorating—tarnishing or turning black?
 Will they guarantee their screen is climate proof and can be washed with soap and water?

Will they guarantee perfect projection regardless of how close your seats are placed to the screen, or angle?
 Will they guarantee perfect projection, without haze, glare or eye-strain?

Will they really guarantee the saving on Current Used?

We are Guided by Our Policy of Six Years to Under-claim Rather Than Over-claim. You Can Rest Assured That We Do Not Exaggerate or Misrepresent. Therefore Feel Secure in Accepting Our Representations at Their Full Worth.

WE GUARANTEE MIRROROIDE FOR FIVE YEARS TO SUBSTANTIATE EVERY CLAIM WE MAKE AS ABOVE. WILL THEY?

MIRROROIDE is the Only Rough or Matte Metalized Surface on Earth—Silver White, Silver Flesh, or Pale Gold. Send for Our Large FREE Samples. TEST, COMPARE with any Screen on Earth. MIRROROIDE IS THE WORLD'S BEST SCREEN—and We Will Back This Statement Up with \$1,000.00 in Real Tests—Tests Open to the Public in General.

MIRROROIDE IS SOLD AT 36 1-9 CENTS THE SQUARE FOOT

Our Latest Pure White Glass Coating, Not Metallic, Ready Mixed, Ready to apply direct, at \$10.00 per gallon. Fire and Waterproof and Guaranteed.

THE J. H. GENTER CO., Inc., NEWBURGH, N. Y. AGENCIES ALL PRINCIPAL CITIES

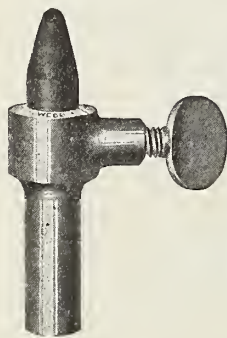

BE NEUTRAL
 PRES. WILSON
DON'T BURN POWDER
"BURN CARBONS"
Burn 'em Up SHORT

with
WEBB'S CARBON SAVER

Extra heavy and best material used throughout
PRICE \$1.00 EACH PREPAID
 Ask about our Terminals.
MOTION PICTURE SPECIALTY & REPAIR CO.
 326 3d Ave. Pittsburgh, Pa.

HANDSOME PHOTOS OF STARS FOR ALCO PRESIDENT

Walter Hoff Seely, president of the Alco Film Corporation, is the recipient of magnificent sepia and platinum pictures of Ethel Barrymore, Beatrix Michelena, Andrew Mack, Jacob P. Adler, Macklyn Arbuckle, Burr McIntosh, Leslie Carter and several other stars to be seen on the Alco program. The photos were mounted in sterling frames and placed in Mr. Seely's newly fitted office on the fifth floor of the Alco building. The photos were all auto-graphed on the silver frames in facsimile of the stars' signatures.

ESSANAY AND LUBIN GO BIG IN SYRACUSE

Special to MOTION PICTURE NEWS

Syracuse, N. Y., Oct. 14.

All of the Essanay productions featuring Francis X. Bushman are proving wonderfully popular in Syracuse, and exhibitors are all pleased with the new story arrangements with the "Ladies' World."

The new Lubin serial, "The Beloved Adventurer," is drawing big, and the little book at 15 cents a copy containing the story is selling like wildfire.

FAVORITE PLAYERS FINISHING SECOND RELEASE

The Favorite Players is finishing its second release, "The Man Who Could Not Lose," and is now outlining the work to be done on their third production, entitled, "The Last Chapter," written by Robert A. Dillon, from an unfinished story by Richard Harding Davis.

All indications point to the fact that the Favorite Players will manufacture only films of the highest class adapted from books of the foremost writers in America.



World Film Corporation

Presents a Shubert Photoplay Feature

"When Broadway Was A Trail" With Barbara Tennant



Released

Oct. 26

Arrange Bookings on these features through

WORLD FILM CORPORATION

LEWIS J. SELZNICK, Vice Pres. & Gen'l Mgr.
 130 WEST 46TH ST., NEW YORK.
 26 Branches Throughout the U. S. & Canada.

LE COURRIER

Cinematographique

28 Boulevard St. Denis, Paris

Directeur: Charles LE FRAPER

Journal hebdomadaire français, le plus important de l'industrie cinematographique.

Envoie numéro spécimen, sur demande.
 Abonnement 12 FR. 50

There Are Several

interesting business boosting schemes outlined in the "Live Wire Exhibitors" department of this issue. It will pay you to read every one of them.

Lantern Slide Mat Co.

Manufacturers of

Lantern Slide Mats and Reel Bands

Prompt Service Prices Right Best Goods

149 W. 35th St., New York

Telephone: Greeley 6414

Manufacturers of the Wonderful Rembusch Patented Glass MIRROR SCREEN and all other kinds of Curtains for Moving Picture Projection

GLASS SCREENS
 Mirror Screen
 Mirror Screen Split
 Glass Transparent Screen for Rear Projection

METALLIZED SCREENS
 Gold Fibre
 Silvercloth
 Mirror Cloth
 Seamless, with stretchers
 White Opaque

Phone Seven-Eleven

F. J. REMBUSCH, Pres.

MIRROR SCREEN COMPANY

Incorporated
SHELBYVILLE, INDIANA

Mr. O. P. Sammons of Denison, Texas, bought a "Mirror Screen," and he writes that he cannot take care of the crowds. His picture is simply the talk of the community. A few second-hand screens for sale cheap.

Eastern Representative, Frank Manning, 125 W. 48th St., N. Y. Phone, Bryant 2416.

The Productions of
Famous Players Film Co. **Jesse L. Lasky Feature Play Co.** **Bosworth, Inc.**
In Association with *Associated with* *Associated with*
 Daniel Frohman David Belasco Lois Weber
 Chas. Frohman Henry W. Savage The Liebler Company Phillips Smalley

Constitute



THESE are a few of the leading theatres throughout the United States showing

Paramount Pictures

They represent the type of theatre that is rapidly superseding the nickelodeon and store show.

Paramount Pictures

provide the class of service that is made to run in these superior houses, and

Paramount Pictures

are replacing the inferior films previously used.

The Highest Grade theatres are daily contracting for

Paramount Pictures

Have you done so? If not, write at once to your nearest exchange.

Paramount Pictures Corporation
 ONE HUNDRED and TEN WEST FORTIETH STREET
 NEW YORK, N. Y.



While 20,000 men are laboring day and night 25 feet underground to complete New York's 282 miles of rapid transit subway, the greatest system in the world, the two main lines of which terminate at this corner

TWO MEN

175 feet above

behind these Windows

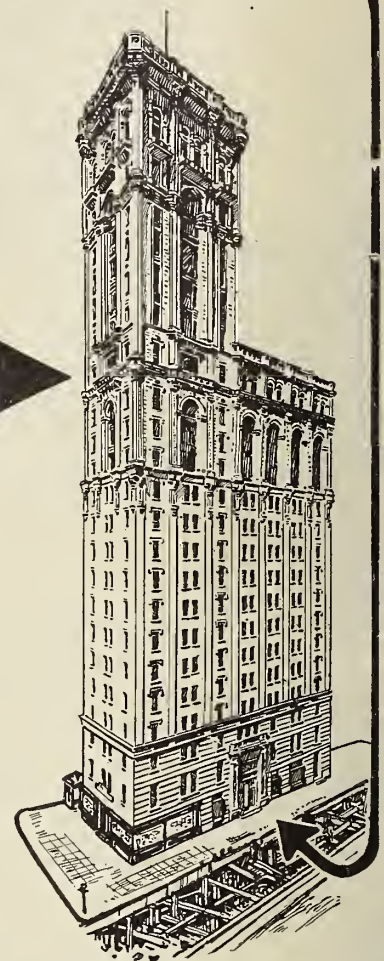

have been laboring on for months

AND HAVE COMPLETED

an innovation which, in its scope and magnitude, is an equally great project, one that means more to an exhibitor than ten *New York Subways*.

It is the newest, the most modern, stupendous, business-like, practical and far-reaching proposition ever advanced in the moving picture field.

It is an innovation which, while benefiting the exchange man and manufacturer, in all its phases—is designed

FOR THE EXHIBITOR

what he has been looking for since the business began—what every theatre, from the 150 to the 3000 seat house, can *USE*—what the progressive exhibitor *MUST HAVE*—and what many exhibitors have offered *large sums of money for*

WRITE NOW

Details of this proposition are *FREE FOR THE ASKING*. Fill out and mail us the attached coupon or mail us a letter. This proposition is ready now so don't delay until your competitor gets the "jump" on you.

Messrs. Morrison
& Poppe,
Gentlemen:

Please furnish me with complete details concerning your proposition for exhibitors. I understand this is to be furnished me free of cost.

..... Manager
..... Theatre
..... Town & State

MORRISON & POPPE

TIMES BUILDING

TIMES SQUARE

NEW YORK

USE YOUR LOBBY—DON'T ABUSE IT

You are mighty **particular** about your **film service**
You are **cranky** about your **music**
You insist upon **clear projection**

BUT DO YOU GIVE THE POSTER QUESTION THE PROPER ATTENTION?

The poster is your greatest asset. It is the medium through which you bring the public from the street into the theatre. **THE RIGHT KIND OF POSTERS ARE ABSOLUTELY INDISPENSABLE.**

THE MORGAN POSTERS ARE THE RIGHT KIND

That is a proven fact. Here's what Maurice Seidlitz, of the Grant Theatre, New York, says, "I have used the **UNIVERSAL** program for over two years. The **MORGAN POSTERS**, coming with the **UNIVERSAL** service, are so far above the average poster on the market today, that comparison would be out of place."

Here's what Ned K. Miller, of the Ditmas Theatre, Perth Amboy, N. J., says, "The **MORGAN POSTERS** now supplied by the **UNIVERSAL** are without an equal, and it is certainly a pleasure to be affiliated in a business way with an organization that is endeavoring in every way to help the exhibitor."

EXHIBITORS ALL SAY THAT MORGAN POSTERS ARE THE BEST

Three-Sheets for One-Reel Pictures

An innovation you cannot afford to miss. If you are booking inferior states right features simply to get the elaborate display of three and six-sheet posters, you are killing your business. **YOU CAN GET 3-SHEETS FOR 1-REEL UNIVERSAL PICTURES AT YOUR UNIVERSAL EXCHANGE**

OR WRITE TO

THE MORGAN LITHOGRAPH CO., Cleveland, Ohio

OR

Service Department

THE UNIVERSAL FILM MANUFACTURING COMPANY

1600 Broadway

Carl Laemmle, Pres.

New York, N. Y.

ALWAYS FIRST IN THE FIELD THE HEARST-SELIG NEWS PICTORIAL

Earliest and Best War Films

Here are the Proofs:

HEARST-SELIG WAR BEATS.

FIRST pictures in America showing destruction wrought at Termonde, Belgium, by the Kaiser's artillery in the attack on that city were exhibited in the Hearst-Selig News Pictorial, reel No. 62, released Thursday, October 1.

IN presenting pictures of Russian prisoners—thousands of them—being herded by the Germans at Koenigsberg, and French prisoners being marched through the streets of Koenigsbruck, the Hearst-Selig News Pictorial secured a remarkable moving picture beat. Nowhere else in the United States or in any country in Europe were these pictures shown. They were exhibited in Hearst-Selig reel No. 62, released on Thursday, October 1.

ON Monday, September 28, in the Hearst-Selig release No. 61, remarkable moving pictures showing long columns of grey-clad German troops, occupying Brussels, the evacuated capital of Belgium, were presented. These were the first and only pictures of the German army in motion, on hostile soil, shown in the United States. The pictures were made by a Hearst-Selig News Pictorial photographer, sent from Holland, who held special German passports and permits. These pictures showed the dusty and battle-worn artillery, infantry and cavalry of General von der Goltz's army, triumphant from Liege, marching through the streets of Brussels, while the silent Belgian populace looked on. They showed more than the marvelous equipment of the German troopers—they were evidence of the strikingly excellent morale of the Kaiser's soldiers, who as they passed the camera, laughed, smiled, joked and waved their hands in greeting. Soup kitchens, from which the legions of the Kaiser are fed on the march and in battle field alike, halted before the eye of the camera, where officer and private made their noon-day meal.

THE first moving pictures from Berlin to be exhibited in the United States were shown in the Hearst-Selig reel No. 58, released Thursday, September 17. The thrilling and exciting scenes that took place in the German capital soon after war had been declared were presented. The Hearst-Selig moving picture camera registered the cheering crowds that gathered before the Kaiser's Palace—artillery rumbling through the streets on the way to the front—and perhaps most interesting of all, the call of Reservists to the Colors, one method of which was a military band which marched through the streets, the Reservists—bankers, business men in afternoon coats and silk hats, workmen and clerks—following behind.

ON August 5, Great Britain announced that it was in a state of war with Germany. Then followed many days of worry and excitement. A trifle more than two weeks later, despite the suspension of steamship traffic and the rigid censorship put into effect in Great Britain—Monday, August 24, to be exact—the Hearst-Selig News Pictorial in reel No. 51 presented the first genuine moving pictures from London. These were pictures of the vast crowds that gathered outside the Buildings of Parliament and the War Office, awaiting the expected Declaration of War against Germany. Three days later, on Thursday, August 27, the Hearst-Selig News Pictorial in release No. 52 presented scenes of recruiting in London and other English cities, and in the following weeks exhibited many pictures of the raising of the British Expeditionary Force.

LESS than one month after the Germans commenced their attack on Liege, the Hearst-Selig News Pictorial was exhibiting in all parts of the United States pictures of war scenes in Belgium; on August 7, the German cavalry screen advanced upon Liege and a few days later the terrific artillery duel commenced. On Thursday, September 3, in release No. 54, the Hearst-Selig News Pictorial presented moving pictures of King Albert of Belgium in Brussels, bidding farewell to the Ninth Regiment, later annihilated at Liege—troops en-training at Brussels preparatory to departure for Liege, and Queen Elizabeth of Belgium caring for the Belgian wounded in the Royal Palace at Brussels, which had been converted into a hospital.

IN release No. 55, Monday, September 7, the Hearst-Selig News Pictorial showed pictures of Belgian refugees fleeing Tirlemont, as scouting parties of Uhlans and the German cavalry screen drew close to that city. In this same reel pictures of Belgian troops advancing from Brussels to meet the oncoming foe, and pictures of Belgians in trenches prepared for the defense of Louvain were shown.

AMONG the more interesting war scenes from Belgium were those shown in reel No. 56, released Thursday, September 10. These were of Belgian soldiers at Waelhelm, preparing to meet the German attack. Some of these striking pictures included scenes of Belgian soldiers destroying and burning houses that stood in the path of the great forts at Waelhelm, and might have obstructed artillery fire. Infantrymen were shown in the act of pouring oil upon the burning homes of Belgian non-combatants.

First in War — First in Peace — First in Popularity

Two Releases A Week—Every Monday and Every Thursday

Demand the HEARST-SELIG NEWS PICTORIAL at Your Exchange

OCTOBER 31, 1914

Motion Picture News

HAS THE QUALITY CIRCULATION OF THE TRADE

MARKET REPORTS NUMBER

JESSE L. LASKY

PARAMOUNT PRESENTS PICTURES



MAX FIGMAN
in Geo. Barr McCutcheon's
Intimate Romance of Stage Life.

"WHAT'S HIS NAME"

5 ACTS 300 SCENES

NOW PLAYING

JESSE L. LASKY FEATURE PLAY COMPANY

LONG ACRE THEATRE W. 48TH STREET N. Y. C.

JESSE L. LASKY
PRESIDENT

SAMUEL GOLDFISH
TREAS. & GEN'L. MANAGER

CECIL B. DeMILLE
DIRECTOR GENERAL

3

THE TREY OF HEARTS

BY LOUIS JOSEPH

THE MASTER PROBLEM PLAY
IN FIFTEEN STORIES

FEATURING
GLEO MADISON & GEO LARKIN
PRODUCED BY WILFRED LUCA





DANIEL FROHMAN
Presents

DAVID HIGGINS

In his original role in the famous racing play

"HIS LAST DOLLAR"

By David Higgins and Baldwin G. Cooke.



In Four Reels
Released
October 29th

An elaborate and spectacular film version
of the greatest racing play ever produced in America.

PRODUCED BY THE

FAMOUS PLAYERS FILM CO

ADOLPH ZUKOR, President,

DANIEL FROHMAN, Managing Director EDWIN S. PORTER, Technical Director

Executive Offices,

213-229 W. 26TH STREET, NEW YORK.



A FOUR LEAF CLOVER

For the Week of October Twenty-six

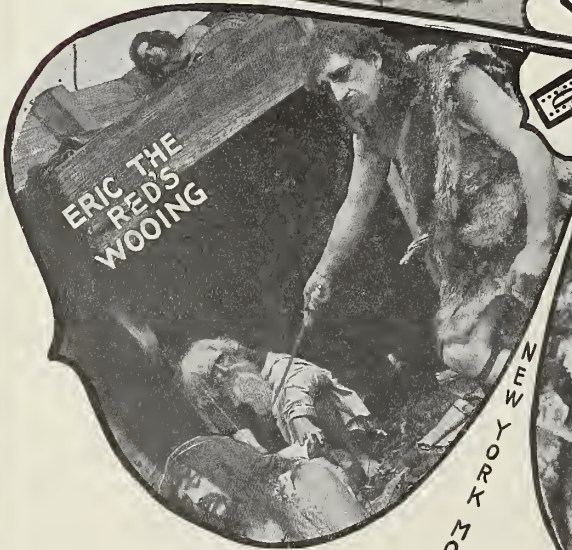

NEW YORK
 20-103 FROY WEN
 20-103 FROY WEN
 20-103 FROY WEN

Released Through the Mutual Film Corporation Exclusively

New York Motion Picture Corporation

42nd Street and Broadway, Longacre Building

NEW YORK

ADAM KESSEL, Jr., President

"A star to which the exhibitor need not hesitate to hitch his wagon."
—N. Y. Morning Telegraph.

Oz Photo-Extravaganzas have solved the Matinee problem for many exhibitors by crowding the houses afternoons as well as evenings.

You, Mr. Exhibitor, want to know something about these New Era Pictures—a distinct advance in Motion Picture entertainments.

"The Patchwork Girl of Oz"

Playing to Crowded Houses everywhere.

"HIS MAJESTY THE SCARECROW"

Now Ready for Release. A Photo-Extravaganza of the famous Musical Play, "The Wizard of Oz," by L. Frank Baum.

Write or wire our New York Office at once for Bookings. Every conceivable advertising help.

READ A FEW OF THE THOUSANDS OF ENTHUSIASTIC PRESS COMMENTS FROM ALL OVER THE UNITED STATES

"If the attendance yesterday at the Iris is taken as a criterion, the "standing room only" sign will have to be used today. The audience seemed to thoroughly appreciate each scene."
—Topeka (Kans.) Capital.

"Altogether the production will prove of value to the exhibitor, because it has the merit of originality and because some parts of the film will send the average audience into roars of laughter."
—Moving Picture World.

"The photoplay is about the best of its kind thus far released under the Paramount Program."
—New Orleans (La.) Picayune.

"The most novel and interesting of the Paramounts. Generally conceded by the press as the greatest production ever shown on the screen."
—Atlantic City (N. J.) Gazette.

"Trick photography, original ideas, the beautiful scenes, and the novelty of the entire production, all combine to cause the picture to be one that will be heartily enjoyed and long talked about."
—Motion Picture News.

"There's much to tickle the risibilities, a great deal that pleases the eye, both in human form and figure and in scenery, and many happenings that will leave the layman dumbfounded."
—New York Evening Sun.

"Here is something entirely different from the usual film production—a photo-extravaganza with its fantastic story elaborately staged. The production is of unusual merit."
—The Billboard.

"It is a real extravaganza (the first in motion picture) and appeals strongly to the adult who tires of a steady diet of dramas or slapstick comedies."
—New York Morning Telegraph.

"A star to which the exhibitor need not hesitate to hitch his wagon."
—New York Morning Telegraph.

The Oz Film Manufacturing Co.

Studio and Laboratories: Santa Monica Boulevard
From Gower to Lodi Sts., Los Angeles, Cal.

New York Office - 220 West 42nd Street

OZ FILM MFG. CO.
220 West 42nd St.,
New York City.

I would like to show OZ FEATURES at my theatre. Please send me full information about them and how they will crowd my house.

Name
Theatre
Address
City
State

If you do not wish to tear this page a post card will do.



UNITED
FILM
SERVICE

COMEDIES—Features—Specials—Every reel of the high standard established by our famous feature releases. There are 42 Warner's Exchanges. Write the one nearest you.

Atlanta, Ga.
Baltimore, Md.
Boston, Mass.
Buffalo, N. Y.
Calgary, Can.
Cleveland, Ohio
Charlotte, N. C.
Chicago, Ill.
Charleston, W. Va.
Cincinnati, Ohio

Dallas, Texas
Denver, Colo.
Des Moines, Iowa
Detroit, Mich.
Edmonton, Can.
El Paso, Texas
Indianapolis, Ind.
Kansas City, Mo.
Los Angeles, Cal.
Louisville, Ky.

Minneapolis, Minn.
Montreal, Can.
Nashville, Tenn.
Newark, N. J.
New Orleans, La.
New York City
Omaha, Neb.
Philadelphia, Pa.
Pittsburgh, Pa.
Portland, Me.

Portland, Ore.
San Antonio, Texas
San Francisco, Cal.
St. Louis, Mo.
Seattle, Wash.
Spokane, Wash.
Syracuse, N. Y.
Toronto, Can.
Washington, D. C.
Wilkes Barre, Pa.
Winnipeg, Can.

Main European Office: 99 Charing Cross Road, London, W. C.

WARNER'S FEATURES, Inc.

New York



EVEN UNTO DEATH

A powerful emotional drama depicting the midnight tragedy that ruined two lives—the bitter atonement—and a woman's undying love. Another Albuquerque masterpiece with Miss Dot Farley as the star.

Write your nearest Warner's Exchange

WARNER'S FEATURES Inc. New York

The Greatest Serial Of All

William J. Flynn

Chief of the U. S. Secret Service

has embodied his personal experiences of over 20 years in the Government Service, in an intensely interesting romance of authentic episodes that prove the adage:—

“Truth Is Stranger Than Fiction,”

and staged under the personal supervision of C. V. Henkel.

THIS Serial will appear in narrative form in the leading newspapers throughout the United States and Canada, and an unusual publicity campaign is guaranteed that will make this the most talked of Serial ever produced.

THE entire Serial tells the adventures of a Lovable Heroine and a Manly Hero, both Secret Service Operatives, but each episode is a complete and conclusive story in itself.

CHIEF FLYNN, in his official capacity, is called upon to review and censor photo-plays, and is fully conversant with the requirements of both the National and Local Censors. We guarantee that all objectionable incidents are eliminated from this Serial.

An Unusual Opportunity For Progressive Exchange Men

We are prepared to immediately contract with responsible representative Feature Film Exchanges for exclusive territorial rights.

Exhibitors are invited to communicate with us at once for preferential bookings as part of the territory will be handled by us in person.

For particulars address
FILM ATTRACTIONS CO., Inc.
Cohan Theatre Building

C. V. HENKEL, Pres. and Gen. Mgr.
No. 1482 Broadway, New York City

WAR—Grim and Ancient—WAR



The Most
Terrible Siege
of Barbaric Times

Told in Five Wonderful Reels

MARKIA

or "The Destruction of
Carthage"

\$200,000 Production from the Ambrosio Studios
Presented by Kinetophote Corporation

Thrilling Love
Story Woven into
This Tale of the
Hatred of Nations



November Releases

Famous
Old Drama

THE SPAN OF LIFE

In Five
Parts

with LIONEL BARRYMORE

THE COMING POWER

Gripping Story of Political Intrigue
(4 PARTS)

THE LITTLE JEWESS

Dramatic Tale of New York Life
(4 PARTS)

K. C. BOOKING CO., Incorporated

IRA H. SIMMONS
General Manager

Telephone: 6072 Bryant

126 West 46th Street, New York City

List of Distributing Exchanges to be Announced Later

BETTER LIGHT

LESS CURRENT

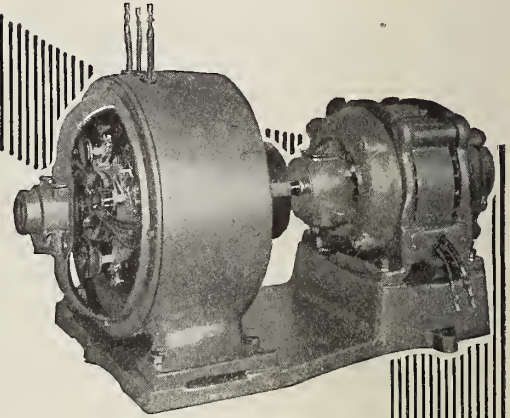
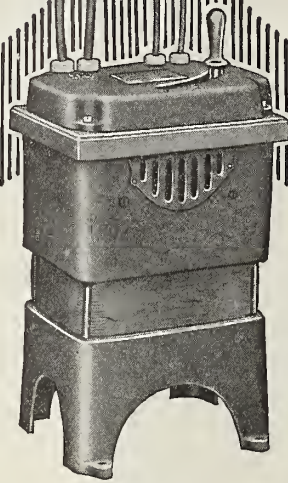
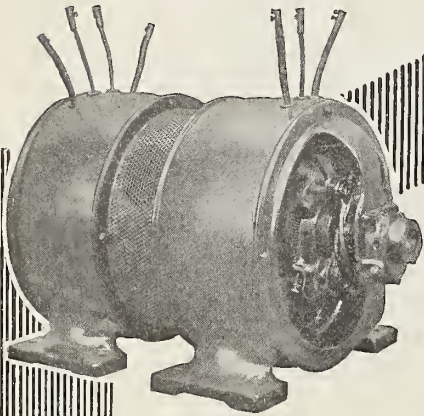

The DC Compensarc lowers the voltage of a direct current supply to that required at the lamp without needless waste.

The AC Compensarc cuts $\frac{2}{3}$ from your lighting bill if you use alternating current.

The AC to DC Compensarc will transform alternating into direct current and reduce the voltage at the same time without need- less waste.

No matter what current you have---Alternating or Direct---or what voltage or frequency, one of the

FORT WAYNE COMPENSARCS

will enable you to secure a light that will give those clear, bright pictures that everybody now demands.

What's the use of paying extra money for special screens, projecting machines, and first run films and then spoil the whole result with poor light? With the Fort Wayne Compensarcs you can get any kind of light you want regardless of the kind or quality of your current supply.

The Compensarcs will give you

STEADY LIGHT. No flickering, no sputtering, even when changing intensities or from one machine to another.

WHITE LIGHT. No yellow streaks, no ghosts.

BRIGHT LIGHT. Three times the light with two-thirds the current.

They are safe, efficient, easy to operate, fool proof and reliable.

FORT WAYNE ELECTRIC WORKS

OF GENERAL ELECTRIC COMPANY

1704 BROADWAY

FORT WAYNE, INDIANA

Compensarcs are so commonly found in motion picture theatres that many people now call all current saving and transforming devices by that name.

But Remember

*If it isn't a FORT WAYNE
it isn't a "COMPENSARC"*



*Send TODAY for this
FREE descriptive booklet*



THE MILLION DOLLAR MYSTERY

Story by Harold MacGrath

Scenario by Lloyd Lonergan

Thanhouser's Million Dollar Motion Picture Production

Ask exhibitors about this remarkable attraction. Let them tell you what a wonderful drawing-card is the Million Dollar Mystery. Watch the theatres on "Million Dollar Mystery Night." See the crowds *come and come*. Then get in touch with the nearest Syndicate representative and book this headliner.

Nineteen episodes of this thrilling motion picture production are appearing throughout the country. *300 leading newspapers are running the story.* The entire story will take 23 episodes. A two-reel episode is released each week. \$10,000 will be paid for the best 100-word solution of the mystery. Give your patrons a chance to win this money.

Syndicate Film Corporation

71 West 23rd Street, New York

Room 411, 5 S. Wabash Avenue, Chicago

or Syndicate Film Corporation Representative at any Mutual Exchange in the United States or Canada

The Thanhouser Three-a-Week

Tuesday, October 27th. "A Madonna of the Poor." (Two reels)

This is an exceptionally interesting drama *written and directed* by Carroll Fleming—"the man with 10,000,000 friends." Fleming's popularity as a writer and director is due to his wonderful ability. In this two-reel play his talents are well displayed. The cast includes John Reinhard, Muriel Ostriche and Dave Thompson.

Sunday, November 1st. "Shep's Race With Death."

The announcement that "Shep"—the Thanhouser dog—is in the cast is sufficient to cause a big demand for the Films. Exhibitors know the remarkable acting for which "Shep" is noted. In this drama "Shep" plays a very important part—actually rescuing frightened Madeline Fairbanks from the path of a fast express train. The scene is thrilling. In this cast are Mrs. Whitcove, J. S. Murray, Marie Rainford, Marion and Madeline Fairbanks and "Shep" himself.

Thanhouser Film Corporation

New Rochelle, N. Y.

Head European Office, Thanhouser Films, Ltd., London, W. C., England

Regular Thanhouser releases are distributed exclusively in the United States and Canada by the Mutual Film Corporation.



SPECIAL FEATURES

General Film Company

TITLE	MAKE	No. of Reels	TITLE	MAKE	No. of Reels
THIRD DEGREE	Lubin	5	IN DEFIANCE OF LAW.....	Selig	3
THOR, LORD OF JUNGLE.....	Selig	3	A KINGDOM AT STAKE.....	Kleine	3
THE BATTLE OF SHILOH.....	Lubin	4	CAPTAIN ALVAREZ	Vitagraph	6
THE LION AND THE MOUSE.....	Lubin	6	OTHELLO	Kleine	5
THROUGH FIRE TO FORTUNE.....	Lubin	5	SHANNON OF SIXTH.....	Kalem	5
JUDITH OF BETHULIA.....	Biograph	4	MAN'S ENEMY	K. & E. Biograph	3
GERMINAL	Pathe	5	IN TUNE WITH THE WILD.....	Selig	3
LOST IN MID OCEAN.....	Vitagraph	3	THE WOLF	Lubin	6
A ROMANY SPY.....	Pathe	3	SHADOWS OF THE PAST.....	Vitagraph	3
A CELEBRATED CASE.....	Kalem	4	MR. BINGLES' MELODRAMA.....	Vitagraph	3
THE FULFILLMENT	Essanay	3	MEN AND WOMEN.....	K. & E. Biograph	3
NIGHT RIDERS OF PETERSHAM.....	Vitagraph	3	THE SECRET OF RING.....	Kleine	3
HARDING'S HERITAGE	Pathe	3	MY FRIEND FROM INDIA.....	Edison	3
DAUGHTERS OF MEN.....	Lubin	5	LIBERTY BELLES	K. & E. Biograph	3
THE OTHER HALF OF THE NOTE.....	Kalem	3	THE ERRING	Lubin	3
HER LADYSHIP	Selig	3	AMBUSHED	Essanay	3
GOODNESS GRACIOUS	Vitagraph	3	SONG OF THE SOUL.....	Kleine	3
OFFICER JIM	Lubin	3	KIT, THE ARKANSAS TRAVELER.....	Kalem	3
DEATH SIGN AT HIGH NOON.....	Kalem	3	CHIP OF THE FLYING "U".....	Selig	3
GAME OF LIFE.....	Selig	3	FAIR REBEL	K. & E. Biograph	3
THE MILITANT SUFFRAGETTE.....	Pathe	5	HOUSE NEXT DOOR.....	Lubin	5
FRANCIS MARION, "THE SWAMP FOX".....	Kalem	3	MY OFFICIAL WIFE.....	Vitagraph	5
A MILLION BID.....	Vitagraph	5	UNCLE BILL	Vitagraph	3
THE FATAL WEDDING.....	K. & E. Biograph	3	THE FORTUNE HUNTER.....	Lubin	6
THE GAMBLERS	Lubin	5	THE VENDETTA.....	Kleine	5
ANNE BOLEYN	Kleine	3	BAREFOOT BOY	Kalem	3
STRUGGLE FOR LIFE.....	Pathe	5	THE WIFE	K. & E.	3
MONGREL AND MASTER.....	Essanay	3	KING OF CHANCE.....	Kalem	3
THE ROYAL BOX.....	Selig	4	THE WAGES OF SIN.....	K. & E.	3
THE CURSE OF CREED.....	Melies	5	THE PLUM TREE.....	Essanay	3
FACING THE FOOTLIGHTS.....	Pathe	3	THE FIFTH MAN.....	Selig	3
BLOOD WILL TELL.....	Essanay	3	THE GOLDEN BEETLE.....	Kleine	4
CONQUEST OF QUEBEC.....	Kalem	5	THE WEIGHT OF A CROWN.....	Lubin	3
THE LILY OF THE VALLEY.....	Selig	3	MARAH, THE PYTHONESS.....	Lubin	3
CLASSMATES	K. & E. Biograph	4	CHARITY BALL	K. & E. Biograph	3
MAN OF THE HOUR.....	Selig	3	HEARTS AND MASKS.....	Selig	3
MR. BARNES OF NEW YORK.....	Vitagraph	6	A FLORIDA ENCHANTMENT.....	Vitagraph	5
LOVE, LUCK AND GASOLINE.....	Vitagraph	3	ROAD TO YESTERDAY.....	K. & E. Biograph	3
THE BILLIONAIRE	K. & E. Biograph	3	THE PAINTED WORLD.....	Vitagraph	3
SPORT AND TRAVEL IN AFRICA.....	Pathe	5	JUDGE NOT	Kleine	4
THE GOOD FOR NOTHING.....	Essanay	4	GARRISON'S FINISH	Selig	3
THE BOER WAR.....	Kalem	5	POWER OF THE PRESS.....	K. & E. Biograph	4
THE THUMB PRINT.....	Melies	4	IN THE GLARE OF LIGHTS.....	Essanay	3
STRONGHEART	K. & E. Biograph	3	THE RED CROSS NURSE.....	Melies	3
LORD CHUMLEY	K. & E. Biograph	4	THE THREADS OF DESTINY.....	Lubin	5
SEVEN DAYS	K. & E. Biograph	3	WHEN THE LIONS ESCAPE.....	Melies	3
TREASURE OF ABDAR RAHMAN.....	Pathe	4	THE GENIUS	K. & E. Biograph	3
'NEATH THE LION'S PAW.....	Melies	3	STONEWALL JACKSON'S WAY.....	Lubin	3
ONE WONDERFUL NIGHT.....	Essanay	4	THE INVISIBLE WAY.....	Kalem	4
WOMAN AGAINST WOMAN.....	K. & E. Biograph	3	THE WOMAN IN BLACK.....	K. & E. Biograph	4
			UNDER THE GASLIGHT	K. & E. Biograph	4

Two Letters

Mr. Fred S. Meyer, assistant to Mr. J. V. Bryson in the management of the Laemmle Film Service at Minneapolis, took part in a recent subscription contest among the ninety-seven representatives of the Motion Picture News. He won first prize. His letter of explanation is particularly interesting because it demonstrates that a quality trade journal, like a quality film or program, is capable of meeting and successfully overcoming any amount of competition.

"The Motion Picture News.

"Gentlemen: In acknowledging receipt of your check for the amount of the first prize in your recent contest, I want to make an explanation.

"When I decided to enter the contest, I anticipated some hard plugging and a maximum of fifteen or twenty subscriptions. I had no more than started when I found that the 'Motion Picture News' was considered some paper in the Northwest. You were right when you said: 'The News is its own best selling argument.'

"Attached is a letter I received this morning, to give you an idea of how good future prospects are in this section. I have got many more subscriptions promised and will send them to you as rapidly as they are received.

"Very truly yours,
"Fred S. Meyer."

Cyril Theatre

S. H. Kahm, Mgr. Phone, N.W. Nic. 2026
114 Hennepin Ave.,
Minneapolis, Minn., Oct. 10, 1914.

"Mr. Fred S. Meyer.

"Dear Sir: Permit me to express my appreciation to you for having sent me the 'Motion Picture News.' I believe that the two dollars I paid for the year is the best investment I ever made. . . .

"I would not call it a magazine. It is an EDUCATOR for the motion picture industry. The knowledge and aid that an experienced exhibitor can derive from it are worth more than fifty times the amount of the subscription. . . .

"If every exhibitor and film man in every branch of the business would read 'The News' each week they would be better qualified. . . .

"Again I thank you, as well as the publishers, for the 'Motion Picture News.'

"Respectfully yours,
(Signed) "S. H. KAHM."

IS YOUR NAME ON OUR MAILING LIST?

If not, this issue of the News is one of fifty-two reasons why it should be. Fill in and mail the form below.

Motion Picture News
220 W. 42d St., New York City

Gentlemen:—Place my name upon your
A Year
subscription list for Six Months for which I have
Three Months

enclosed _____.

Address all copies to

Mr. _____

of the _____ Theatre

St. Address _____

City _____ State _____

The subscription rates are \$2 for one year; \$1 for six months; Fifty cents for three months. In Canada, \$2.50 a year. Foreign, \$4 a year.

A New Thanhouser Production To Follow The Million Dollar Mystery—

—a newer, greater serial story
by Harold MacGrath, to be run in
more than 500 leading newspapers.

—a more startling, more sensa-
tional photoplay by Daniel Carson
Goodman, consisting of 20 episodes—each a
complete and baffling portrayal of Hindu mysticism and science.

ZUDORA

Thanhouser's Greatest Photoplay

November 23rd is the date set
for the first release of this new Than-
houser masterpiece. A two-reel episode will be
released each week.

In the cast are 1000 American people
—including the favorites: Marguerite Snow, Harry
Benham and James Cruze. 3000 scenes are necessary.

EXHIBITORS: This is positively the most won-
derful attraction ever offered. It is an independent
release and may be obtained regardless of the regular program
being used. But quick action is necessary if you wish to secure
this feature. Get in touch *at once* with the Thanhouser-Syndicate
representative at any Mutual Exchange in America. Or write to



**THANHOUSER SYNDICATE
CORPORATION**

71 W. 23rd Street, New York City

Produced by
THANHOUSER FILM CORPORATION
New Rochelle, N. Y.

Producers of The Million Dollar Mystery



NOV 2 1914

"When You See It
In 'The News'
It's NEWS"

Motion Picture News

HAS THE QUALITY CIRCULATION OF THE TRADE

"The Exhibitors'
Medium of
Communication"

Tel. 7650 Bryant

NO. 220 WEST FORTY-SECOND STREET

New York City

Volume X

OCTOBER 31, 1914.

No. 17

Wanted:—Some Workers

IF we are to have an exhibitors' national organization, have it reasonably soon and reasonably strong, the necessity for workers, *real workers*, grows more and more apparent.

In the first place, a national organization cannot be had until there are strong, active leagues in every state and in those large cities that demand active local association.

These units must make the groundwork of a national body. The efficiency of the national body will depend very largely upon the individual strength of the organization units.

* * *

IN the second place, we shall not have state and local leagues of any strength until in each instance one or more men will step forward, throw off their coats and work!

It is hard work, and often it is thankless work, but if the exhibitors are to have an organization—which means their prosperity, yes, their very existence—someone, everywhere, has got to step into the breach.

* * *

WHEREVER we have such men—men patterns, energetic, unselfish—we have good local and state organizations. When such men are lacking, there is no organization.

Jeup in Michigan, Brylawski in Washington, Pearce in Baltimore, Rath, Furniss and Steppes in Minnesota, Bullock in Cleveland, Trigger, Bauernfreund, Whitman in New York, Tugwell and Cory in California, Finnegan in Texas, Denton in New Jersey, Sweeney in Chicago—here are some *workers*, and there are several others, together with able and willing co-workers and supporters.

* * *

THE whole list is an imposing one. It inspires hope and confidence.

Also, we know that there must be still other men in states and cities where leagues are now dormant or non-existent—men just as capable of hard work and self-sacrifice. There are. But they must come forth—*now*.

* * *

THE theatrical managers have perfected an organization. But that was comparatively easy.

They simply began at the top—got together the

warring factions in the legitimate, vaudeville and burlesque fields—only half a dozen companies owning circuits comprising all the theatres—and the thing was done.

But picture theatres are for the most part independently owned.

There is but one way to group them for united, successful effort, and that is through local and state associations founded and run for common good.

* * *

BUT these organizations will never be created or maintained—and this has been the history of every association of every nature—except one man, or a few good men put *and keep* their shoulders to the wheel.

* * *

SURELY no exhibitor denies the necessity of organization.

Certainly it cannot be possible that there are men, today wailing over exorbitant rentals and low admission prices, struggling against licenses, taxes, Sunday closing, censorship—*when organization and only organization will correct these serious difficulties*.

But the painful, unbelievable fact is that there *are* such men—several thousands of them.

They don't *deserve* the name "exhibitor," they don't *deserve* success.

But they exist, and their only salvation is for some few leaders to organize them and save them in spite of themselves.

* * *

LAST week the Baltimore League succeeded in having a certain film rental cut in two and made an outlaw theatre raise its price from two to five cents. And here and there—not in many places—good work is being done by local and state bodies.

This kind of work can be done everywhere—but *only with and through an organization*.

* * *

ORGANIZERS, volunteer organizers are wanted. Don't wait for the next man.

If he's asleep, let him sleep. He will either go out of business eventually, or else come begging your organization to let him in.

Be the *worker* your organization must have.

Volunteer, *yourself*. *And start now.*

WILLIAM A. JOHNSTON.

AUSTRIA BANS ENGLISH AND FRENCH FILMS

Exhibitors in Austria-Hungary have been forbidden by the police of Vienna to show films of the following brands:

English: British and Colonial, Clarendon, Warwick, Hecla, Britannia, Cosmopolitan, Cricks & Martin, Hepworth, Big Ben, Barker, Franco-British, Hildare, Hilarity, Splendor, Urban, Victoria, Dragon, Invicta, Exclusive, Famous Players, Western Import, Union Public Co.

French: Pathe, Gaumont, Eclair, Eclipse, Cosmograph, Film d'Art, Film Parisien, Monofilm, Filma, Minerva Film, Aubert, Polichinelle.

And all the Russian brands.

A disregard of this manifesto will result in the revocation of license and six months' imprisonment for the guilty party. All pictures must be shown with their original brand, in order to let the audience know where the films come from.

This embargo on the above firms does not apply, however, in the case of a manufacturer putting out a film lauding Austro-Hungarian patriotism.

In this tabooed list of English films are the Famous Players and Western Import pictures, of American origin.

NEW CHAIN OF THEATRES IN BUFFALO

A. R. Sherry, well known in Buffalo, N. Y., theatrical circles, has been appointed general manager of the Continental Enterprises, Inc., a company recently formed to promote motion picture theatres. The corporation at present has two theatres, one located in East Aurora, N. Y., known as the Bell Theatre and the other on Niagara street, Buffalo, which will be known as Bell No. 2.

The theatres of the company will be numbered in consecutive order as they come under the control of the Continental. Each will have the name of Bell and its number. Mr. Sherry has been connected with various Buffalo theatres as manager, among them being the Lyric, Family, Academy and Shea's Hippodrome. The offices of the new company are at 505 General Electric Building, Buffalo, N. Y.

PATRONS RESPOND TO RISE IN PRICE

Special to MOTION PICTURE NEWS

Pittsburgh, Oct. 21.

The Star Theatre at Export, Pa., a town of 2,000 inhabitants, put one over on the larger theatres in the larger towns.

"Sealed Orders" was put on at the theatre at 25 cents admission and the proprietor cleaned up on the picture.

This is the first time in the history of the town that a picture of that kind has been shown and the first time in the history of the town that the people paid more than 10 cents for admission to a motion picture show.

Pittsburgh Exhibitors Rally for Protection

First Mass Meeting Held to Deal With Question of Obtaining Repeal of Obnoxious Laws—Decide Matter of Supporting Candidates

Special to MOTION PICTURE NEWS

Pittsburgh, October 21.

A MASS meeting to which all who are interested in the motion picture business are invited, is called for Sunday afternoon, October 25, at 3 o'clock, in the Olympic Theatre, in Fifth avenue, Pittsburgh, at which time the subject of supporting the various candidates for State Senate and Legislature will be discussed. It is plain from the way the motion picture men have been aroused during the past few weeks that only the candidates who favor them will be countenanced.

Among some of the questions to be taken up at the next meeting of the State Legislature will be the new building code law, the repeal of the obnoxious state censorship law, which will also settle the poster question in this State, and several others.

If the new building code law is permitted to go through it will undoubtedly mean the putting out of business a number of theatres that are at present able to operate under the old law, and it will work a hardship with many of the small and large exhibitors of the state.

In the State we have already had a taste of censorship and the exhibitors and the exchange men alike are opposed to the bill. There can be only

one way of assisting in ridding the State of these obnoxious laws, and that is to get together and fight them, tooth and nail. That the candidates, no matter upon what party ticket they stand, are willing to promise anything in order to be elected is true, but the exhibitors this time are determined that they will make sure of their men, and they are going to fight stronger now that they have gotten their organization in good fighting shape.

The matter of using their screen for the advancement of the chances of their candidates will also come up for discussion. That they can do a lot of good in throwing a slide upon which is printed the names of the candidates they favor upon the lighted screen has been shown by the way they have helped in this district with the advertising of many charities, and that this method will undoubtedly be used seems assured.

The candidates are already getting busy with the exhibitors, and they are more than willing to lend their assistance in getting some of the laws killed, but the men who will be favored by the exhibitors are the ones that will stand by their given word and lend their assistance in killing bills that work a hardship on the motion picture business.

G. L. McCoy, Jr.

Georgia Is Building Theatres "Over Night"

A New House in Atlanta, Another in Macon, One Planned for Columbus, While Several Elsewhere Have Been Reopened

Special to MOTION PICTURE NEWS

Atlanta, Ga., Oct. 20.

GEORGIA exhibitors refuse to echo the "hard times" cries. Calamity howlers must do their howling in vain if they are expecting sympathy from this section. There is convincing evidence in the form of splendid new theatres in all parts of the state to substantiate the above.

The general opinion is that there will be just as many new theatres this fall as ever before, and probably more. Certainly this year's crop means the investment of more money in buildings and fixtures than in many previous years.

Atlanta's contribution to the fall building is the Strand, on Peachtree street, said to be the most costly motion picture theatre in the South. The Strand has been open several weeks and is doing a rushing business.

Macon follows with the new Palace Theatre, a \$30,000 house, which has recently opened, and with important changes in the Majestic, which now is under the management of J. F. Arnold.

Columbus stands well up in the list with expensive improvements in the Majestic, which has been leased by J. B. Melton, of Macon. Mr. Melton has

announced that he proposes to erect a new theatre next summer. Although the Majestic is primarily a playhouse, it is understood that Mr. Melton intends to introduce some of the best photoplays.

In Athens both the Alamo and Crystal Theatres have been reopened, the former under the management of M. H. Epps, of Atlanta.

The Colonial, a new theatre at Mill-edgeville, has just opened, under the management of Edmund Reid.

Exhibitors and exchange men are of the opinion that the above is just a beginning on the list of new houses of the year.

LINTON K. STARR.

HISTORIC NEW YORK THEATRE JOINS FILM RANKS

Charles A. Taylor has taken a five-year lease on Daly's Theatre, Broadway and Twenty-ninth street, which has been closed for over two years, and will present motion pictures.

The theatre will reopen about November 1, and the first offering will be "Yosemite." The year's rental for the theatre, which will be renovated and redecorated, will be \$30,000.

Pearce Urges Union of New York Forces

At Meeting of Greater New York Association for the Installation of Officers, Held in Hotel Marlborough on October 16, President of the National Organization, Who Made Special Trip from Baltimore for the Occasion, Sees Amalgamation an Accomplished Fact in Few Weeks

A SPECIAL meeting of the Greater New York Association of Exhibitors was held October 16 at the rooms of the association in the Hotel Marlborough, New York City.

The occasion was the installation of the recently elected officers. About forty members were present.

President Pearce came on from Baltimore, and made an earnest plea for the amalgamation of the Greater New York Association, the Cinema Club and the State League under one banner.

Among other things he said:

"I have been very anxious about the delay in amalgamation in New York State. I really thought that this would be effected almost as soon as the convention at Dayton was over, and I am so anxious to see this brought to a speedy and successful finish that I have made a special trip over here to see if something cannot be done to hasten action and finally close what I believe every man here will agree should have been closed a good while ago.

"I appreciate fully the somewhat delicate complications surrounding conditions here. I'm not losing sight for a second of the impediments that have to be overcome before the perfect and complete amalgamation of the state can be accomplished—but I firmly believe that conditions are such throughout the state right now that this amalgamation can be accomplished within a few weeks.

Warns Against Further Delay

"If this is true, and we find it possible to do this without more than a few weeks' delay, then let us so adjust everything else, and be sufficiently broad minded as to side track anything that might have a tendency to hinder progress along this line.

"I have just had the pleasing assurance of Mr. Trigger, just recently back from a trip up state, that he felt sure from his interviews with exhibitors that they were ready for amalgamation, and that as soon as other state matters were adjusted this could be accomplished without further delay.

"I can't urge you too strongly to further the cause of amalgamation in New York State in every way you find possible; the state needs it, the League needs it, and I'm sure you'll find it will prove the one best big action you could take. Finish this up quickly and let New York State stand solid as the strongest part of the League that is to be found in the whole country."

John D. Denton, of Hasbrouck Heights, N. J., who at present is busily engaged in reviving the New Jersey State League, was asked to install the

new officers, and did so in a most pleasing manner.

The following officers were installed: President, William A. Landau, Heights Theatre; vice-president for Manhattan, Morris Needles, Auditorium Theatre; vice-president for Brooklyn, William H. Hollander, Old Postoffice Theatre; vice-president for the Bronx, A. Coleman, of Coleman's Theatre; vice-president for Queens, Robert C. Whitten, Goldenrod Theatre; recording secretary, Adolph Weiss; financial secretary, William Brandt, Clinton Court Theatre; treasurer, Grant W. Anson, Star Theatre; finance committee, Edward Valensi, Windsor Theatre; P. Rosensen, Greenpoint Theatre, and A. Baurenfreund, Model Theatre.

Samuel H. Trigger, retiring president, who heads the executive committee, composed as follows:

Samuel H. Trigger, Tremont Theatre, chairman executive board; M. Tischler, Rivington Casino; P. Gootenberg, Tuxedo Theatre; Wm. Hilke-meier, Jefferson Photoplay; A. A. Corn, Grange Theatre; N. Hirsch, Royal Theatre; S. Rhonheimer, Ronly Theatre; M. Oestreicher, Franklin Theatre; Lee A. Ochs, Costello Theatre; Edward Valensi, Windsor Theatre; J. Forster, Crescent Comedy; L. F. Blumenthal, Palace Theatre; A. Phillipson, Madison Theatre; Charles Fisher, Decatur Theatre; C. R. Martineau, Hanover Theatre; S. Schwartz, Crown Theatre; H. Hartsall, Bunny Theatre; W. B. Fulmer, Montauk Arcade; P. Rosenson, Greenpoint Star; A. Bauernfreund, Model Theatre; M. Marias, Rockaway Theatre; M. Warshower, Mt. Morris Theatre; A. Weiss, Avenue A Theatre.

In his speech of acceptance, Mr. Landau, who already indicates that he will conduct his office in a virile and business-like manner, paid high tribute to the retiring president. Mr. Landau said that he would devote an hour or two per day to his executive duties but that he would not let the office make a slave of him and interfere with his own business, as had been the case with Mr. Trigger. Every other officer joined him in words of praise for Mr. Trigger's untiring and self-sacrificing efforts in building up and maintaining the Greater New York Association.

Tribute to Ex-President Trigger

The MOTION PICTURE NEWS wishes to add its own tribute to Mr. Trigger as an organization man. Like every active and forceful personality, Mr. Trigger has his enemies and friends. But there is one thing that not an enemy can say of him—that he has ever misused his office, shirked his duties or even put his

own business affairs ahead of the interest of the organization. If every local and state League in the country had a Sam Trigger, we should have today a strong and comprehensive national organization.

President Pearce at Meeting in Hackensack

THE key-note of enthusiasm was struck at the meeting of the Bergen County, N. J., exhibitors, at Hackensack, when reorganization of the State of New Jersey was under discussion. President Pearce thought that the war tax measure may prove to be a blessing in disguise, in this locality at least, by reason of the fact that it has awakened to action every exhibitor in this particular section, and brought home to him the absolute need for perfect organization and harmony throughout the state.

While exhibitors appreciated the success in the substitution of the graduated scale for the original flat rate bill, and the fact that the League has really worked wonders in having this bill with its equitable graded features passed by the Senate, yet almost every member expressed the belief that with the right sort of organization—the solid front, powerful, well directed forces of a League all over the country that didn't know a weak link, it might have been possible to secure a decided reduction in the scale of taxation, if not to eliminate the tax on theatres entirely.

President Pearce found the members especially anxious to perfect the strongest sort of state organization, not only to protect perfectly their interests as a state branch, but for the general good of League members everywhere and the advancement of the League as a working factor of sufficient power and influence to sidetrack anything detrimental to its advancement and welfare, and to secure every advantage possible wherever opportunity afforded.

President Pearce was especially pleased to note the activity in this locality. It's the best sort of evidence of an awakening that's sure to bring forth results that will be worth looking at. With such perfect organization as the members of Hackensack Heights and Bergen county have as their aim, they are sure to accomplish such a measure of success and improvement as will not only reflect the greatest credit on themselves but prove to be the making of one of the strongest links in the nation-wide organization of the Motion Picture Exhibitors' League of America.

THE MOTION PICTURE NEWS CHART

City or Exchange Center.	1. Conditions since May 1. 2. Outlook	New theatres opened since May 1.	Theatres closed since May 1.	Reasons for closing.	Class of film in greatest demand.	Decrease or increase in admission price.	Demand for feature films.
ALBANY, N. Y.	1. Unsatisfactory 2. Mildly hopeful	Two	Two	Competition and lack of business	All equally popular	General decrease	Very marked
BIRMINGHAM, ALA.	1. Stationary 2. Good	None	None	None	Melodramas and comedies	Increase for features only	Growing
BILLINGS, MONT.	1. Satisfactory 2. Favorable	None	None	None	Comedies and classics	None	Strong
BOISE, IDAHO	1. Fair 2. Good	None	None	None	No preference	None on regular program	Varied
BUFFALO, N. Y.	1. Fair 2. Favorable	Ten	None	None	Classics and clean society drama	None	Marked
BUTTE, MONT.	1. Good 2. Excellent	None	None	None	Best of every kind	Stationary at fifteen cents	Strong
CANTON, O.	1. Satisfactory 2. Satisfactory	None	None	None	Comedies	Ten cent price prevails	General
CHARLESTON, S. C.	1. Good 2. Good	Several replacing small theatres	Several small theatres	Varied	Classics, comedies, melodramas	None	Growing
DES MOINES, IA.	1. Good 2. Good	None	None	None	Melodrama: "Human Interest"	None; ten cent move a failure	Programs preferred
ELIZABETH, N. J.	1. Unfavorable	Two	None	None	Comedy and problem plays	None	Strong
HARRISBURG, PA.	1. Excellent 2. Excellent	25% increase	One	Remodeling	Good comedies and dramas	Partial advance to ten cents	Strong
LOS ANGELES, CAL.	1. Unsatisfactory 2. Very bright	Ten*	None	None	Classics and comedies	Ten cents prevails; trend is upward	Strong
LOUISVILLE, KY.	1. Thriving 2. Excellent	Six	Four	Bad location	Comedy and melodrama	Generally stationary	Strong
MILWAUKEE, WIS.	1. Good 2. Good	10% increase	None	None	Society drama, and comedies	Trend toward ten cents	Strong
MINNEAPOLIS, MINN.	1. Satisfactory 2. Excellent	Several	None	None	Classics and comedies	None	Overwhelming
NEWARK, N. J.	1. Uncertain	Six	None	None	Classics and good comedies	General increase	Strong
NEW HAVEN, CONN.	1. Excellent 2. Excellent	One**	None	None	Melodrama and good comedies	Five and ten cents prevail	Strong
OMAHA, NEB.	1. Thriving 2. Excellent	5% increase***	None	None	Comedy	General movement for increase	Strong and growing
ROCHESTER, N. Y.	1. Excellent 2. Excellent	Two****	None	None	No preference	Increase	Popular only in big houses
SALT LAKE CITY, UTAH	1. Satisfactory 2. Satisfactory	2% increase	One	Bad management	Increase	Increase	Strong
ST. LOUIS, MO.	1. Normal 2. Good	Three	Three†	Change of policy	Classic and spectacular drama	About the same	Growing
SPRINGFIELD, ILL.	1. Satisfactory 2. Satisfactory	Several‡‡	None	None	Comedies	None	Variable
SPOKANE, WASH.	1. Satisfactory 2. Promising	Two	None	None	Straight drama, news weeklies	None	Strongest in suburban districts
SEATTLE, WASH.	1. Improving 2. Favorable	Four	None	None	Good comedies and two-part dramas	Increase	Real features in great demand
WASHINGTON, D. C.	1. Satisfactory 2. Excellent	Several	A few small houses	Lack of business	No preference except for quality	Ten cent scale prevailing	Strong
BALTIMORE, MD.	1. Depressed 2. Favorable	Three	Two	Summer dullness	No preference except for quality	None	Growing
PHILADELPHIA, PA.	1. Fair 2. Favorable	Several	For alterations only	See preceding column	No preference except for quality	Fluctuating	Strong demand for big features

*City of Los Angeles, three; San Bernardino, one; San Diego, one; Pasadena, one; smaller towns, four.

**Formerly a vaudeville house; one in course of construction.

***Seventeen new theatres completed in Nebraska during September. Twenty more are nearing completion.

OF NATIONAL FILM TRADE CONDITIONS

Decrease or increase in rental prices.	Feature programs at small houses.	Effect of features on admission price.	Exhibitors' profits on features.	Average No. of reels at theatres.	Do serials continue popular?	What exhibitors think of film stories.	City or Exchange Center.
Rising	Too costly to be a success	Increase	Substantial at large houses	Four; feature nights, six	Yes	Constant improvement	ALBANY, N. Y.
Same for features	Successful	Increase to 10-25 cents	Satisfactory	Three to four	Fairly popular	Constant improvement	BIRMINGHAM, ALA.
Rising	Usually successful	Increased to fifteen cents	Fair	Four to six	Generally, no	Lack of variety and harmony	BILLINGS, MONT.
Increase only on special features	Usually successful	Advanced	Satisfactory	Four to eight	No	Improvement on all programs	BOISE, IDAHO
Rising	Frequently unprofitable	None	Satisfactory	Five to six	When not too long	No improvement; too many features	BUFFALO, N. Y.
Stationary	Successful	None	Satisfactory	Four to seven	Yes	Satisfied	BUTTE, MONT.
Increasing	Fair	None	Fair	Four to seven	No	Too few good comedies	CANTON, O.
Practically the same	Usually successful	None	Satisfactory	Four to six	Generally, yes	Generally satisfied	CHARLESTON, S. C.
Rising	Unsatisfactory	None	Unsatisfactory	Four to seven	Extremely popular	Improving	DES MOINES, IA.
Features rising	Public and exhibitors differ	None except by contract	No money in them, say exhibitors	Seven	No	No improvement; too few comedies	ELIZABETH, N. J.
Rising	Of uncertain value	None	Uncertain for smaller houses	Five to six	Yes	Material improvement	HARRISBURG, PA.
10 to 50%	Profitable because of lower rental	Increase only in smaller cities	Satisfactory	Five	Excellent in suburban towns	Westerns overdone	LOS ANGELES, CAL.
Programs same; features rising	Business pullers	None	Slight at small theatres	Four	At residential theatres	Constant improvement	LOUISVILLE, KY.
Rising	Successful	Increase	Satisfactory	Four	Generally, no	Generally satisfied	MILWAUKEE, WIS.
Increasing	Successful	None	Satisfactory	Five to eight	Extremely popular	Improving	MINNEAPOLIS, MINN.
Generally stationary	Successful	None	Satisfactory	Seven to eight	No	One reel comedies poor	NEWARK, N. J.
Stationary	Successful	Increase	Satisfactory	Seven to eight	Yes	Satisfied	NEW HAVEN, CONN.
Rising; slight decrease in features	Successful	Raise in price to fifteen cents	Satisfactory	Four	Yes	Scarcity of short pictures	OMAHA, NEB.
Usual season fluctuation	Unsatisfactory	Uniform increase	Good in large theatres	Six	Mildly popular	Satisfied	ROCHESTER, N. Y.
Rising	Generally good	Rise in prices	Satisfactory	Four to five	Generally popular	Improvement in features	SALT LAKE CITY, UTAH
Slight decrease	Successful	None except at five cent houses	Satisfactory	Four to seven	Popular, but considered too long	"Same old stuff"	ST. LOUIS, MO.
No decided variation	Not markedly popular	Rise in prices	Good in larger houses	Three to five	Opinion varies	Constant improvement	SPRINGFIELD, ILL.
No decided change	Varies with location of theatre	Slight increase; not general	Satisfactory	Five	To a limited extent	General satisfaction	SPOKANE, WASH.
Increase	Variable	None	Satisfactory	Five	To a limited extent	Programs falling in quality	SEATTLE, WASH.
Rising	Successful	Higher in individual cases	Satisfactory	Four to six	Popular in residential sections	Need for strong one reelers	WASHINGTON, D. C.
No decided variation	Popular	Advanced to ten cents	Slight on account of low admission	Four to seven	In residential sections	General satisfaction	BALTIMORE, MD.
Drop in certain lines of features	Successful	Increase in many cases	Satisfactory	Four to eight	Yes	General satisfaction	PHILADELPHIA, PA.

****In course of construction.

†Running as legitimate houses.

††This includes central Illinois.

REVIEW OF TRADE CONDITIONS REVEALS PROSPERITY THROUGHOUT COUNTRY

Outlook Is Everywhere Encouraging, Even Where Business Has Slackened During the Past Few Months—Few Dull Periods Laid to the War—Many Movements for Higher Admission Prices in Progress—Features in Almost Universal Demand, but Complaint Is Made of Dearth of First-Class One and Two-Reel Pictures—Opinions on Serials Vary

Special to MOTION PICTURE NEWS

Albany, Oct. 21.

THE Albany film men are not calamity howlers nor do they want to be classed with those individuals, but there is not one who will not tell you that business for the last six months has been bad, in fact, very bad. Of course, a fall off in attendance is always expected during the summer months, but a majority of the managers declare that this has been the worst summer since the institution of the silent drama.

Other years' expenses have been met, with perhaps a little profit, this year instead of clearing expenses there has been a loss. Some of the houses, that is the larger ones, have come through all right, but even these can't show any kind of a profit.

Not one of the managers can tell the direct cause of the wane of the picture enthusiasts other than that it must be from the general business depression in Albany, which seems to be hitting all businesses.

In the West Albany yards lying idle are ninety-four New York Central engines. This means that the West Albany shop's payroll decreases over \$1,000,000 in a year. A loss of that much money to a city means a loss to most every line, especially to the places of amusement, and the film theatres are the ones that are being hit the hardest.

It is only a question of how long these theatres can keep up at this small price of admission for the film service; in fact, everything connected with the business is going up in price.

The war has sent carbons up to \$7 a hundred, just \$5 more than they were before.

Competition is another thing that is helping kill the business. Albany at present is well taken care of with motion picture theatres, in fact, there is no room for any others. With these changes there are now twenty-six motion picture houses in Albany, twenty-seven counting the Colonial. This last theatre is now running pictures, but it is only a matter of time when it will go back to its old policy of pictures and vaudeville.

One pleasing feature of the business in Albany is the class of people who are patronizing the silent drama houses. It has always been known as the amusement for the medium class in Albany, but now it is not a strange sight to see an automobile drive up in front of any of the theatres.

On all sides are heard words of praise for the class of films the various companies are now turning out. "Great!" "Best ever!" "Getting better all the time!" are a few of the expressions from the managers. There are some who say the films are very much worn when they get them, but this cannot be laid to the manufacturers. The fault finders are the ones who are running the cheaper programs; that is, getting the films after they have made the run of several houses. Generally speaking, there is not a kick registered about any of the products of the film companies.

Feature productions have always been more or less popular, but at present are more sought for than ever.

It is not easy to try and pick out the class of film that the patrons desire. Each section of the city has its likes and dislikes and the comedy, educational, topical, travel, classic and the sensational film goes equally as well in this city. This has not always been the rule, but within the last few months all has changed. The success of serial pictures has been marked.

Special to MOTION PICTURE NEWS

Buffalo, Oct. 21.

THE film situation in Buffalo and Western New York is, on the average, in a fair condition. The question which is uppermost in the exhibitors' minds of this section is the general increase in rental service, which in the past has been raised to an almost prohibitive figure.

Meetings have been held protesting against the raise and from present rumors it looks as though the managers are going to refuse to pay the increased prices. Although the trend has been toward the ten-cent house no five-cent theatres have closed; in fact, no photoplay theatres have closed their doors this year in Buffalo.

Exhibitors announce that they are drawing a much better class of patronage. Buffalonians are crowding the theatres showing features every night. The legitimate houses are noticing this movement toward the pictures, as inroads have been cut into their business. It seems that the day of the two-dollar legitimate in this city is "marching toward Waterloo."

Although the audiences have increased, film rentals "followed suit" and everything connected with the operating end of the theatre increased in price, admissions have remained the same, and that is ten cents.

Feature productions continue to hold sway and both local exchanges and state rights buyer are doing a good business in Buffalo with this class of film. If some of the local exchanges continue to boost prices, the state rights buyer is going to do more business.

While features have made money for some of the large theatres they have not for some of the smaller places, as patrons are expecting to see features wherever they go with the consequence that exhibitors are forced to show them with their regular service and at the five-cent price in some instances.

Features have to make themselves in Buffalo; that is, they require a four-day or even a week's run in the larger downtown houses to make money for the next theatre in the outlying district which may choose to show it. A feature is demanded every change in the larger houses.

Exhibitors do not think that exchanges are extending greater co-operation to them in operating their theatres. The idea with the exchange is to get as much as possible out of every exhibitor, in fact, there are no two exhibitors in Buffalo, says one manager, that are paying the same price for service. One man is afraid to tell another what he is paying for service for fear that he will divulge the secret that he has "got it for less than the other fellow."

The European war has effected exhibitors to the extent that it has boosted expenses in many ways, especially in carbons and condensers.

As regards the future, all exhibitors think that business will get better and many think that there should be a set market price for film service and that the class of film story has got to get better.

It will not be enough to have a star, which many local managers think is necessary, but an entire cast capable of acting. One manager thinks that the first man to open an exchange with a set rate for service which everyone knows and which exhibitors can pay or leave, will make a great success and eventually put some others out of business. It is predicted that many of the smaller theatres, with prices connecting with the operating end of the theatre about doubled, will find it necessary to close.

It is noticed that local motion picture theatres are doing more advertising in the daily and Sunday papers than ever before. This is indicative of the "power of the press" as regards theatrical advertising. Motion pictures are getting the same amount of space as the legitimate houses and the local papers are devoting, besides their regular amusement pages, entire sections devoted to "booming the films."

Exhibitors are taking advantage of this free publicity and getting their advertisements in these sections. Electric signs in the downtown section and atop large buildings have been utilized by some of the theatres for advertising purposes.

If expenses continue to go up, this year is going to be a much worse one than last, from a financial standpoint. Even now exhibitors are commencing to figure out how to reduce the operating end of their houses. If the war continues, retrenchment will be the "order of the day."

CHARLES B. TAYLOR.

Price of Carbons Only War Effect on Rochester

Special to MOTION PICTURE NEWS

Rochester, N. Y., Oct. 21.

LOOKING over the motion picture field in Rochester, exhibitors find much on which to congratulate themselves, and very little over which to feel blue. The business is thriving, and the number of picture houses is increasing constantly.

By this time, the downtown houses of Rochester have established themselves so firmly that they may be said to enjoy a constant patronage, graded according to the entertainment offered, and the prices asked. Little by little, as the attractions are improved, a better class of patrons is attracted.

The tendency has been among exhibitors to hold admission prices on the same scale as last spring, except when some special attraction is offered. Local exhibitors have about made up their minds that ten cents and fifteen cents are as much as can be asked.

The outside houses stick to the five-cent shows. A few of the downtown houses get ten cents at night, and five cents in the afternoon, while the special feature houses get fifteen cents as a rule, and twenty-five cents for special attractions.

Feature productions are in great demand here, but they must be good ones. Rochester boasts a discriminating motion picture public, and a special feature must really be "the goods."

The regular program houses downtown seldom depart from their straight service, and offer but a poor field for the state right buyers. The regular programs are so uniformly good that there is little profit in going into the market for special features. As a rule, too, the regular houses do not care for the multiple reel features, as their audiences like shorter films, dropping in for short times only.

Occasionally houses in the outskirts use special features, but not as first runs.

This city regards the prices asked for feature productions as excessive, especially the prices for the entire feature services say of two releases a week.

One local house subscribed to a special feature service and dropped it after one month, claiming that it could get better results by buying features in the open market, instead of being tied up to one service and compelled to take its features, good or bad.

The smaller theatres of this city have never taken very cordially to the big features of any service, even at sixty or ninety days.

Good features are invariably money-makers for the big houses. Admission prices always go up when a house using only regular program features books special features.

The average program in Rochester consists of about six reels, though some of the downtown houses go as high as eight.

Rental prices for films have shown only the usual fluctuation with the season's changes.

Serial pictures have not made a big hit in Rochester. In fact, one house dropped one of the big ones, after starting it.

About the only effect of the war on the theatres is the boost in price of carbon.

ARTHUR R. TUCKER.

Newark Looks to Sunday Opening to Combat War Depression

Special to MOTION PICTURE NEWS

Newark, N. J., Oct. 21.

GROWTH of the motion picture business in this city has been checked temporarily by conditions resulting from the European war and the film men see in Sunday opening their only hope of fair profits during the winter.

The picture business in Newark has expanded amazingly during the last year, and houses devoted to the silent drama have taken their place among the foremost amusement enterprises in the city. It is improbable, however, that there will be much further development until general business conditions improve.

Nearly every picture house in the city is drawing a better class of patronage than ever before and some of them are attracting the same classes that frequent the highest priced dramatic houses.

Admission prices have increased generally. The five-cent admission is speedily being eliminated and there are very few houses in the city where admission may be gained for a nickel, at evening performances at least. Some houses, principally in the centre of the city, get as high as thirty-five cents for the best seats at evening performances. Only a year ago, five and ten cent admissions were the rule.

The great call is for feature pictures. The bigger the feature, the more demand there is for it. Most of the houses have a constant policy and do not alter their prices when features are shown. In fact, most of them show features at every performance.

Opinions of exhibitors differ as to the quality of the film stories, although the consensus is that the pictures secured in regular programs are no better than they were a year ago. There seems to be a general complaint about the poor quality of one-reel comedies. Classic dramas and good comedies without too much slap-stick work seem to be most in favor with the public. The exchange men say there is a big demand for war features. There is general dissatisfaction with serial pictures, and if the expressions of exhibitors mean anything, there will be a mighty small demand for these pictures in Newark when the present supply is exhausted.

JOHN W. HAWKINS.

Features Prove Strong Drawing Cards in Connecticut

Special to MOTION PICTURE NEWS

New Haven, Conn., Oct. 21.

NEW HAVEN is one of the most promising of cities in the motion picture field. The financial depression that seems general all over the country is felt here also, yet it has had little effect on the industry in this city. As a matter of fact, thousands of dollars have been spent in the past few months for improvements, and a larger amount is still in reserve, to be devoted to the same purpose during the winter.

The city is proud of the fact that the few theatres that have been forced to shut down are only the airdomes, driven out by approaching cold weather.

Feature pictures are exceedingly popular in this city. Likewise the serials are strong drawing cards, and likely to continue so. Neighborhood, as well as central houses, use the big pictures, and continue to hold the patronage of mixed classes. As a rule, feature pictures cause an increase in admission prices, and pay exhibitors well, so that an excellent market is afforded feature dealers and state rights buyers.

Neither the war nor any other cause has affected the local market greatly, notwithstanding that the price of carbons has advanced so greatly, and other necessities seem likely to become more costly.

Rental prices remain unchanged, both for feature and regular service, and the only thing that motion picture men can talk of as being expensive is the necessity for their changing programs daily and showing from six to eight reels at each performance.

AMSTER SPIRO.

Elizabeth Feels Effect of Slack Business

Special to MOTION PICTURE NEWS

Elizabeth, N. J., Oct. 21.

MOTION picture exhibitors probably have suffered more as a direct result of the influence of the European war than any other business enterprise in Elizabeth or vicinity. More than 4,000 employees, half of the working force, at the Singer Sewing Machine factory in this city have been laid off.

The railroad shops have laid off large numbers, and other manufacturing concerns have cut down the list of employees, materially until it is estimated by the Citizens' Committee for the Relief of the Unemployed that 15,000 persons in Elizabeth at the present time are without work.

The local industrial depression was felt almost at once among the motion picture exhibitors. The smaller houses where an admission of five cents is charged have been the greater sufferers. However, the bigger houses have not escaped. From the standpoint of patronage there was little to complain of until after the outbreak of the European conflict.

Although the film patrons of Elizabeth are strong for feature pictures, local managers insist that there is no money in them. Exhibitors do not hesitate to place themselves on record as being in favor of dealing directly with the producer. Patrons are calling for real comedy that is free from the suggestion of burlesque, and managers are meeting demands with the statement that good comedy films are the most difficult of all films to secure. Dramatic films are played up by exhibitors as the best of the drawing cards.

The reproduction of some big Broadway success never fails to draw well.

The topical and educational films are attracting fewer than any other. They are not unpopular—they are simply endured. But serial pictures have the local managers frowning. They are no longer favorites with the public, who complain that the pictures are too long drawn out, savor too much of the impossible, far-fetched in plot and, after the first couple episodes, tiresome. It is safe to predict that local managers will not dabble in serial pictures for many months to come.

FRANK M. BOYCE, JR.

EASTERN CITIES RIPE FOR HIGHER PRICES

Special to MOTION PICTURE NEWS

Philadelphia, Oct. 21.

THE Philadelphia feature exchanges report good business on big features, which are running well ahead of the smaller features.

The Famous Players Exchange, handling Paramount pictures, reports an average of one new contract daily, and pre-Paramount releases booking very strong by those houses which are not in a position to run the Paramount program on account of restricted territory.

One of the best going films at the present time is "Sea Wolf," due to the recent publicity campaign waged on Market street. Incidentally, the Palace theatre, at which "Sea Wolf" was shown, has learned the wisdom of advertising and now takes space in the newspapers with more or less regularity. The owners used to say that they got the crowds anyway, but they now find that "it pays to advertise."

The Alco Exchange also reports good business, with new contracts constantly being signed. Ethel Barrymore, in "The Nightingale," broke box office records at the Regent theatre, Seventeenth and Market streets.

The Electric Theatre Supply Company says that its big features are booking about 25 per cent. more rapidly than the smaller ones. Since the break-up of the Exclusive Program, which they handled during the past year, they have made arrangements to supply their customers with American film. With this end in view they have secured the Alliance Program and are now negotiating for the products of other American manufacturers.

The Syndicate Film Corporation continues to book the "Million Dollar Mystery," and estimates that the contracts to date, in this territory alone, will total over \$100,000.

The Continental Feature Film Company states that business is fair, but it expects the new two-reel Keystone features to take like wildfire. The mere announcement that these would be handled outside of the service has brought numerous requests for bookings on "Dough and Dynamite."

The Box Office Attractions Company seems to be doing very well, as it says, "for a newcomer in this locality."

The drop in prices of features to two dollars a reel by the Special Feature Department of the General Film Company has hit a great many of the smaller exchanges.

The Cahuff Supply Company reports that it finds nothing the matter with business, which is a very good indication, because when an exhibitor is not making money he naturally hesitates to invest in any more supplies than are absolutely necessary.

From the other viewpoint, those exhibitors who have been seen say that business is not as good as it should be at this season of the year, possibly due to the recent warm spell. And this is in spite of the various reports of ex-

changes that the exhibitors are booking the larger features.

The manager of the Lafayette theatre says that he is not doing any more business now than he did during the summer, due, no doubt, to the fact that his competitors, who were either rebuilding or had closed for alterations, are now open again.

The Jefferson theatre has seemed to strike better luck with smaller features than with the larger ones, not because of the features themselves, but because of weather conditions, it so happening that the smaller features were shown on pleasant days, while the big features happened to strike inclement weather.

The General Film Company reports business as very good on service. Their features, which are already released, are booked almost solid until Christmas.

The Eclectic Film Exchange, which has taken over all Pathé releases, say that business has doubled in the past month over the normal for the summer. The manager, who has interviewed about twenty-five or thirty exhibitors, says that the consensus of opinion is that big features have come to stay.

On the whole, the outlook for a good winter business, by both exchanges and theatres, seems to be excellent. The advent of the large feature running in the legitimate theatres will tend to raise the interest of the better element in motion pictures, with the result that new patrons will be made for the neighborhood houses, and the theatre owners will also be encouraged to increase their prices.

The Chestnut Street Opera House, which, until this year, has never run anything but the very best and highest-priced legitimate attractions, has for the present at least gone over to a photoplay policy.

JULIAN M. SOLOMON, JR.

Baltimore Wants Best Pictures at Same Price: Features Popular

Special to MOTION PICTURE NEWS

Baltimore, Oct. 21.

A GROWING demand for the better class of pictures, but with no advance in the price of admissions, is the problem which is confronting the Baltimore exhibitors now. Many of the leading theatre owners maintain that there is but one thing to do, and that is advance the price to 10 cents.

Many feel that it is only a matter of a few months before all of the better class motion picture houses will be charging 10 cents as the regular admission price.

Of course there will always be the 5-cent house, the theatre of the single and double-reel subjects, but there is a growing demand for the higher grade productions, and the latter cannot be secured with profit to the exhibitor unless he gets twice the present admission rate.

"The Baltimore audience is different from that of most cities, and it requires close study to find out just what will please the patrons of your house," said Mr. Bernard Depkin, manager of the New Pickwick, 115 North Howard street.

"Numerous productions which went big in other cities attracted little or no attention here. To carry a pleased audience in this city, you have to give them well-executed photoplays with the leading characters impersonated by the players they know.

"Frequently a picture version of a well-known play falls flat because the cast is unknown. The Baltimore audience is not unappreciative, however. Give them what they want and they will pay for it. In my judgment it is coming to the ten-cent proposition in this city. There is so much good film stuff being made now, both by the leading manufacturers who release through a regular service as well as by independent makers that it is impossible to get all of the good stuff. An up-to-the-minute house wants the best of the releases, however, and in order to get it it is necessary to pay much more money than four or five months ago. The picture public is growing daily, and with the increase in the interest it is natural that the public becomes more critical and no business can live unless it keeps pace, or, in fact, just a little ahead of its patrons."

There is a decided better demand in Baltimore this fall for feature productions. Features were very popular last spring, but with the near approach of cooler weather, exhibitors are mapping out their campaign for the winter. The outlook for features has never been as bright as it is at present.

Not only are the larger houses booking more features, but nearly all of the smaller ones, houses that formerly used only the regular service, are carrying one or two feature days a week. There is also a tendency to have one or two days a week when the larger features are presented and the price of admission made 10 cents in place of 5 cents.

A. F. GILLASPEY.

Ten Cent Show Growing In Popularity at Washington

Special to MOTION PICTURE NEWS

Washington, D. C., Oct. 21.

FROM reports received from the exhibitors and exchange men of the national capital, the outlook in the motion picture field is excellent—the best in years. The consensus of opinion is that the industry has progressed in many ways.

The photoplays are of a much higher character, the photography is better, the dramatic art has improved and the filming of standard works has proved advantageous. The producer is paying more attention to details and accuracy. Features have become a demand on the daily program. The slapstick comedy is popular in the downtown districts, but there is a call for some change in this type.

The exhibitor is paying more attention to balancing his program and is more particular about the class of pictures offered.

The ten-cent show is becoming more popular, which has enabled the exhibitor to offer a better program and give more comforts to his patrons. Among the large newer houses that have entered the field may be mentioned Crandall's Theatre, Moore's Strand, the American, Avenue Grand, Savoy, Apollo, Empire, Regent, Liberty and Washington. The largest of these is the Strand with a capacity of 2,200, the others ranging from 500 to 1,000. Tom Moore contemplates building a five-cent house on the site of the Plaza which will excel in beauty and cosy anything now in the city, with a large seating capacity.

The personality of the actors and actresses plays a large part in the popularity of productions. Francis X. Bushman is always sure to bring a packed house. Speaking of this, Harry Crandall said, "The Bushman pictures certainly are money-makers for me, and I use every one that is released."

Mary Pickford is another big favorite. Tom Moore remarked: "The single-reel Pickford pictures which I am using daily proved one of my biggest assets during the summer, and they show no signs of losing favor now." There are

hosts of other stars who are always popular, and the celebrities of the stage always attract patronage.

In this connection it might be well to state that some producers are making a serious mistake in always putting their best players in multi-reel features, thus leaving the single reels without the strong support they demand.

"There is no denying that this is the day of the big features and the big theatre," said Tom Moore, "and I will say without reservation that the Shubert productions stand among the best. I had more requests by phone and letter—hundreds of them—for a return engagement of "The Lure" than any play I have had at the Garden." THEODORE FRANKLIN.

Film Drama Suffers Less Than Other Lines of Business in Harrisburg

Harrisburg, Pa., Oct. 21.

THE last three months have seen a remarkable growth in the number of motion picture theatres in this city, which can be taken, perhaps, as the best indication of how local exhibitors generally view the prospects for the expansion of the business. There are now fifteen theatres in operation in Harrisburg.

The best evidence of how experienced exhibitors here feel with respect to the future of motion pictures is the fact that two of the brand new houses that were built during the summer and are now drawing big audiences were put up by men who already were successfully operating theatres. In each of these cases the exhibitor is now running two theatres instead of one.

The fact that Harrisburg has now, roughly speaking, about 25 per cent. more motion picture houses than it had last spring may be regarded by conservative business men as an increase that is a little too rapid. Perhaps some of the new theatres may not pay as well at the outset as was anticipated, but those who note the growth of the city and the increasing percentage of the population that is becoming interested in film drama are of the opinion that it will not be long until there is plenty of patrons for all the present theatres.

The new houses are all of the most modern type of construction.

The same high class of patronage that the local theatres have recently been enjoying is still noted. In the last three months the theatres in the central or business districts of the city have uniformly advanced the price of admittance to ten cents, while in the outlying sections the price continues to be five cents. It will not be surprising, however, if ultimately the ten-cent rate becomes general.

The reason for the advance in the business sections is that the exhibitors declare they could not live without it, in view of the keen competition and the higher rentals for films. This latter condition is attributed in part to the fee that is exacted from manufacturers on every new film that passes through the hands of the Pennsylvania Board of Censors for approval. The manufacturers, the local exhibitors say, are shifting at least part of this increased burden on the backs of the exhibitors in the form of higher film rentals.

Feature films are still in demand to some extent, but certain of the leading exhibitors are beginning to become undecided as to whether the public is not tiring of features. Features, like other films, are renting for higher figures, and there is a question whether their permanency is assured in Harrisburg, especially among the smaller theatres, although thus far features have proved money-makers for those displaying them and properly advertising them. There is no additional charge for admittance here when feature films are offered.

Serial films seem to have drawing qualities when used in this city and this is attributed largely to the fact that patrons become interested in the actors with whom they have become familiar and like to follow them through succeeding adventures. The motion picture theatres have not suffered, perhaps, as much as some other lines of business.

V. H. BERGHAUS.

CONDITIONS IMPROVING IN THE SOUTH

Special to MOTION PICTURE NEWS

Birmingham, Ala., Oct. 20.

LITTLE change, if any, is to be noted in the motion picture theatre conditions of Birmingham in the past three or four months. Business, generally speaking, is said by theatre operators to be about on a par with this time last year.

This is the only effect of the "war scare" and the current "hard times" as far as the Birmingham motion picture theatre operators are concerned; that is, this fall shows no apparent improvement in patronage or general conditions over last fall, while previous years have shown a steady development and growth.

The same number of theatres are now in operation as three months ago. There have been no changes.

As to the class of patronage compared with three months ago, local exhibitors say they notice an improvement in that the business and professional men appear to be patronizing picture shows here in larger numbers. The Birmingham "legitimate" theatrical season opened two or three weeks ago, and the patronage of these theatres is admittedly not as good as in former years. Why? Most people agree that the motion picture shows are responsible because they are satisfying more and more people in so far as they desire a little daily or weekly amusement.

Admission prices have not changed, except in this one way. There appears to be more feature films run than formerly and these are put on at from ten cents to twenty-five cents. They draw good crowds, too, and local exhibitors say the feature productions are in better demand. They follow the policy, however, of not mixing a usual program with a feature film if possible.

When a feature is put on it usually is run alone or at most with one other short film. This is due to the belief that people, while the show may be good, do not desire a too lengthy program.

The outside feature productions, apart from the regular program material, are in good demand and are renting for about the same as formerly, it is said.

Some slight advance in rental prices for regular programs has been experienced by exhibitors, over which, of course, they are not enthusiastic. They attribute it to the disappearance of the European made films from the American market and therefore a resultant greater demand for the American made films.

No complaints regarding the films other than the ordinary, which come regularly in every-day business, are made by local exhibitors. The war films, which of course attract much public attention at present, are censored by each exhibitor before being produced and any parts liable to excite a demonstration are cut out.

Exhibitors generally try to run a varied program.

Serial pictures are popular in a certain way, but Birmingham exhibitors are not particularly enthusiastic over them. They state the main trouble is that if a patron for some reasons misses the first one or two installments of the picture, he always feels he has missed a part of a connected story and will not go to see the remaining installments of the serial if another theatre happens to be putting on a regular program at the time he is in the notion of "taking in" a picture.

RALPH R. SILVER.

No Complaints of Poor Business in and Around Louisville

Special to MOTION PICTURE NEWS

Louisville, Oct. 20.

THE motion picture business in Louisville at the present time is in a thriving condition, according to local exhibitors, and most of the houses will have a nice profit to show for the year 1914.

There are more motion picture theatres in the city now than ever before, and few are complaining of poor business.

Four small houses which were carelessly located in the outskirts have closed in the last year. It is the opinion of exhibitors that a better class of patrons than formerly are now attending picture shows for the reason that a higher class of films are being shown today than ever before.

The prices of admission are about the same as heretofore, five and ten cents. One local house often gets as high as fifty cents for the best seats, exhibiting, as it does, nothing but high-class feature films. With this one house omitted from calculation, the average price of admission is about eight cents. Feature films are in great demand.

Although the feature film rents for more than it used to, the demand for this class of entertainment necessitates the managers of most of the houses having a feature on at least one or two days of the week.

Exhibitors say that there is no doubt that features increase the receipts of the box office, but that, in many cases, after the film is paid for the margin of profit is slight.

Exhibitors have not to contend with the question of censorship, or any very harmful legislation in Kentucky, so the picture men are able to give all their attention to the development of their business. Just now most of them are developing business by the use of the feature film. Although there is a diversity of opinion as to how well the feature pays in net profits, it is conceded that the feature film draws patrons to the theatre and that is what every manager is looking for.

To sum up the situation in Louisville, where there are about thirty houses now in operation, the business can be said to be in a sound condition. The supply does not seem to be greater than the demand.

Almost all of the exhibitors are making money, and some are making lots of it. The exhibitors seem to be well satisfied with conditions, and there is a bright outlook for the future.

F. D. VANOVER.

Improved Programs Bring Better Results in Attendance at Charleston

Special to MOTION PICTURE NEWS

Charleston, S. C., Oct. 15.

THE number of theatres in operation in this city is the same as in the last quarterly market report, although a number of theatres have gone out of business. The new theatres which have taken the place of the old are of greatly improved type and the capacity is generally greater.

The class of patronage in the theatres here has remained practically the same during the past three months, with a slight tendency toward betterment, due to the improvement in the programs offered. Although there has been a decided improvement in the latter, prices have remained the same, and it is thought that an increase is not warranted at this time.

Feature productions are in much greater demand than they were during the summer months. The rental remains practically the same. The features generally have proven to be money makers for the exhibitors, but in several instances where the features were not especially good this does not hold true. Admission prices remain the same when features, aside from the regular program, are exhibited, except in rare instances, when the offering is one of unusual local interest.

It is the general opinion of local exhibitors that the quality of film stories has not improved to any remarkable degree, although they continue attractive.

The exhibitors have few complaints to make regarding films and these are of a minor nature. This is a rather difficult matter to ascertain in respect to the quality of the films, as the local theatre-going public is greatly varied

in its opinions, some liking one thing and some another in the way of film stories, and seldom all agreeing as to the same film, whether good or bad.

The local exhibitors are of the opinion that the smaller

exchanges will ultimately be eliminated! that there will be little or no change in the policy of operating theatres and that the quality of films must be constantly in the ascendant.

HARRY A. BOGGS.

NOTE OF OPTIMISM IN MIDDLE WEST

Special to MOTION PICTURE NEWS

Springfield, Ill., Oct. 21.

WITH new theatres in a number of cities of central Illinois, the winter season of the motion picture business opens promisingly and with a better class of pictures than ever before. So far, attendance has been good and bids fair to remain so, even to increase.

In cities where new theatres have been opened these theatres for the most part are of larger seating capacity, attractively decorated inside and out, and in a majority of cases managers have promised feature pictures as a part of their offerings.

Exhibitors express themselves as being pleased with the kind of pictures that the manufacturers are turning out. The pictures, both in photography and story, are constantly getting better and as a result patrons are expressing more satisfaction with the bills offered.

Among some exhibitors there is a tendency not to break into their regular bills with features.

Several cities in the central part of the state have one house which shows feature and big productions exclusively.

These are offered at increased admission prices and are, generally, drawing paying business.

The three-reel bill at an admission price of five cents continues to attract the most business. Theatres offering five first release pictures at ten cents are attracting good business, however.

In some small towns where competition is keen longer bills are offered for a nickel.

There seems to be no demand for any certain kind of pictures unless it is for comedies. Exhibitors who are keen try and book programs that appeal to their particular patronage, and just about every exhibitor has his own problem in this respect.

C. C. CHEADLE.

Canton Complains Against Small Exchanges Raises Admission to Ten Cents

Special to MOTION PICTURE NEWS

Canton, O., Oct. 20.

A GENERAL admission price of ten cents has at last been fairly well established in this city. A few years ago the airdome craze attacked the city and seriously interfered with natural development of the business. These amusement places had a tendency to lower the grade of pictures and, as would naturally follow, the price of admission.

Two houses now show five-cent programs four days in the week. Three houses charge ten cents for all performances.

The general consensus of opinion among exhibitors is that the serial pictures now in vogue are unsuccessful.

No complaints are made against quality of films, with the single exception of the general opinion that not enough good comedies are being made. These would be royally welcomed in this city.

Exhibitors here are looking forward to the elimination of the small exchanges on which reliability cannot be placed. Most of the exhibitors of this city deal with exchanges in Cleveland. In that city there are 24 exchanges now. It is believed here that this number will be soon cut down appreciably by the close competition and that afterwards the surviving exchanges will be bigger and of the kind in which absolute reliability can be placed by the exhibitor.

GILBERT H. CANTERBURY.

So Called Hard Times Fail to Affect St. Louis Exhibitors

Special to MOTION PICTURE NEWS

St. Louis, Oct. 20.

THE film industry in St. Louis is normal. There is talk of hard times, but it is not the penny-pinching, nickel-grasping, business-throttling hard times that make people stay at home, afraid to spend a cent. It is merely the panicky feeling engendered by the European war.

If anything, there is a better condition among film men, taking it all around, than there was six months ago.

Admission prices, except for the bigger features, are about the same. Some of the five-cent houses have the habit of adding a four or five-reel feature to their bill for Saturday and Sunday nights, and raising the price of admission to ten cents. Ordinarily the prices are the same, with a majority of houses charging ten cents.

Features are growing in popularity. Many of the houses that book the regular exchange programs seem willing to add outside features from state right buyers and pay the extra price, in addition to the service from the regular exchange.

The class of patronage is improving, a good condition brought about largely by such exhibitors as Sievers, of the New Grand Central, who has conducted regular campaigns of advertising designed to attract the better class of people. There always was a friendly feeling for films in St. Louis among the better class of people, but now the feeling seems even better than usual.

There is little or no complain from exhibitors about unfair treatment from the exchanges regarding the price of service, but there is complaint, and lots of it, about the kind and quality of the stories of the releases.

One exhibitor is particularly bitter about this phase of the business. "There are so many good subjects they might make," he says, "so many good, tense little stories of real life, that the people like and want, and they ignore them all and give us the eternal 'old mill at midnight,' 'wronged wife,' 'jealous husband cured of his suspicions by his wife's brother,' and such.

"And many of the stories that would be good are spoiled by the director, who puts what he calls the 'punch' in them, which usually takes the form of an automobile accident, or a man sneaking up a dark alley with a knife in his teeth and a bundle of important papers in either hand."

Another exhibitor who would not be quoted, complains about the quality of acting in the short release. He says as soon as an actor displays any ability he is taken out of the one-reel work and booked as a star, and the one-reel, which is really the backbone of the business, is hashed up with new performers, who regard the work merely as a training camp for the feature end of the game.

The better class of pictures, the really big stuff, is wanted. That, and clean comedy, seem to take best with St. Louis audiences. Classic drama and spectacular subjects are very popular. The serials all take well.

There are criticisms, however, on the fact that the serials are all too long drawn out. Some of them have no end in view; in other words, they will be released as long as the people will stand for them. The manufacturers seem to consider pictures solely from the standpoint of footage. This is not good; it is too much like buying books by the pound; it is poor business policy, and it is very bad art.

There is no likelihood of any change in the method of marketing films; changes of that sort will necessarily be slow, and there is a tendency to keep to the rut.

A. H. GIEBLER.

Movement in Nebraska Toward Higher Admission Prices

Special to MOTION PICTURE NEWS

Omaha, Neb., Oct. 20.

NO time during the last few years has seen a more decided step toward advancement in the motion picture business throughout the central West than the last three months. It has been marked by the increase of exhibitors who go into the field to make themselves permanent, and the consequent decrease of the fly-by-night exhibitor and the exhibitor who conducts all his regular business with all his attention, and lets his motion picture theatre get along the best it can.

This permanent population is gradually increasing in Nebraska. There are still many, many prosperous towns needing the presence of a live-wire exhibitor. This will be brought home more forcibly by the statement that Nebraska has the smallest motion picture theatre population of any state in the union that is near its size. It might seem almost unbelievable on account of its geographical position.

There is a general movement throughout the state for an increase in admission prices. Practically every theatre has a sliding scale of prices. When a big feature is being shown the price is increased. It is astonishing how many downtown theatres in Omaha charge only five cents for admission on program days.

There is an excellent field here for combined effort to get a regulation price if there were only concerted action on the part of managers.

Cut-throat competition has a big effect on some of the downtown corner theaters. Where there is more than one theatre in a block there is bound to be competition of the bitter kind. Some of the exhibitors have not yet learned the uselessness of cutting their own throats in an effort to outdo their neighbor.

Such competition is all that prevents the existence of uniform prices in Omaha. Outside the city there has been a marked increase in admission prices. Everywhere the charge is ten cents for regular programs and 15 cents for features. Several theatres have started charging as much as 25 cents for features and say it is a success.

One noteworthy feature of the last three months in this territory is the effort of exchangemen for more co-operation between themselves and exhibitors.

Exhibitors and exchangemen agree that co-operation should be their key word from now on if success is to be assured. An effort to allow greater freedom to the exhibitors in selecting their programs and in choosing between features and regular service is being made. Exhibitors are confident it will result as they desire. Exchange managers are trying their best to arrive at a solution to the problem that will at once satisfy the demands of the exhibitors and at the same time not be too hard on the exchanges.

Exhibitors and exchangemen both are agitating a higher

scale of admission prices. The higher prices will enable the exchange men to deal in better service and in higher grade films, and will allow the exhibitor to give his patrons the kind of service and pictures they are most desirous of going to the theatre to see.

One thing is apparent in this territory: Better times for exhibitors and exchangemen are directly ahead. Nebraska, while small in motion picture population, is on the clearer side of a big effort to attain better conditions, and the leaders are men in the business for permanent success and who are building their own theatres, studying their patronage and using every effort to become leaders in their line. GUY LEAVITT.

In Face of War and Strong Competition Des Moines Business is Good

Special to MOTION PICTURE NEWS

Des Moines, Oct. 20.

EARLY in the summer an effort was made to raise the price of all picture houses to ten cents. The local associations, never strong, failed to stick. The plans crashed.

If the houses had stuck together the scheme might have been successful, at least until the war broke out. It is probable that by this time the public would have been so well initiated into the ten-cent idea that even the war would not have chilled the purse strings into inactivity. Some of the exhibitors declare that the public would not stand for the raise.

To declare that the exhibitors are drawing a better class of patronage is answered differently by different picture men. Observation would encourage the belief that there is an improvement along this line. It is not striking, but it is pronounced enough to be noticed.

Features in Des Moines as a rule are not regarded as money-makers. The regular program is given the preference.

It is difficult to determine how some pictures take. Even the attendance will not always determine this. There is a large patronage that will take a chance at anything. In view of the fact that the picture actor is not applauded it is not always possible to tell if the play takes. If the play is appreciated the fact is not manifested in the funeral silence of the spectators. If it happens to meet disapproval there is the same grave-like silence.

On the whole, the picture business is good. Competition is strong. rents have advanced, but the war has had no appreciable effect on the attendance, excepting perhaps to shorten the supply of carbon. The relations between exhibitor and exchange man have not always been cordial, but they are growing closer together and in this locality they are doing business on a very friendly basis.

CHARLES C. WENTZLER.

VERITABLE BOOM IS ON IN NORTHWEST

Special to MOTION PICTURE NEWS

Minneapolis, Oct. 20.

THE motion picture business in Minnesota and the Minneapolis trade district which reaches far beyond the state boundary, is progressing rapidly, is on a firm financial footing and is becoming rated among the important business factors in every city and town. And it has become an influential factor in the life of each community.

The motion picture houses of Minneapolis and St. Paul are now taking nearly as much billboard space as the legitimate theatres, and the picture houses are occupying a more prominent place in the minds of the majority of the people than the regular plays.

Shakespeare in film, accompanied by refined music, would draw the crowd away from the regular houses with the prices equal, in the opinion of many persons versed in the show business.

Admission prices in Minneapolis have not increased except at one house.

Features are the pictures that are in demand in Minneapolis, and hence they are money makers. The patrons have taken to features like ducks to water. Of course, they cost money, but then a good feature never fails to draw a house if the patrons have ample notice of it.

The Minneapolis exhibitors have carefully avoided a raise in price when state rights films are shown, though the so-called legitimate theatres raise the price. The state rights prices have remained about the same, but some predict that in the future the regular agencies will gradually crowd out the state rights proposition.

The tinted educational films and views are being talked about in Minneapolis. Several theatres are showing them, and this is going to be one of the ways of "seeing Europe" soon.

There is just one thing that will beat the live serial. It will beat anything. That is the first live authentic European war film of the big armies. If it is ever obtained, as no doubt it will be, Minneapolis film fans will pay \$1 each to see eight reels of it, and will never complain. Minneapolis people are walking the streets looking for good war films.

The relations of exhibitor to distributor in Minneapolis continue on a friendly basis. It has been noticed that the successful, wide-awake exhibitor who studies his patrons, has no difficulties at the agency. He goes to market with a definite idea of the general subject he wants.

He can tell the agent what he wants, and the agent will get him the best he has.

R. G. MARSHALL.

No Hard Times in Milwaukee With Admission Going Up

Special to MOTION PICTURE NEWS

Milwaukee, Wis., Oct. 21.

THE effect of the war on the business in this city may best be illustrated in the words of Ahrent Trinz, manager of the Rainbow theatre, Twenty-seventh street and Lisbon avenue, who said: "The only time the war hurts business is when the program is poor."

There has been a very healthy increase of photoplay houses since last May, this increase amounting to about 10 per cent. Out of all of these new houses but one was built in the downtown district, the rest being in the outskirts. All of them are of the latest and most improved design, the present building code making cheap and shoddy houses a thing of the past.

Most of the new houses have a seating capacity well over the five hundred mark and quite a number of the houses now seating five hundred are enlarging their capacity to a thousand seats. Though there has been an increase of new houses, none of the old ones have closed.

With the gradual improvement in the quality of the pictures, the class of patronage has changed for the better, as has the admission price. Where a ten-cent night was a rarity with the outskirt houses in the past it is now the rule, most of the houses playing to ten cents three or four nights a week, while the Alhambra theatre has boosted the price of its downstairs seats to twenty cents in the evening.

The exhibitors and exchange men seem about evenly divided in regards to feature productions, some claiming that the demand for this sort of picture is falling off while others say that it was never as large as it is today. The big features are renting for more money than ever, while the small ones are getting cheaper; in fact, many of the little ones can be bought for a song.

A house must have the location and capacity to handle the bigger features, say the exhibitors, and the little fellow with the limited capacity cannot handle a production of this kind any more than could a tank opera house handle a two-dollar Broadway attraction.

Features have not, with a few exceptions, proven a money-maker, if considered from the standpoint of the box office, but as a business builder they have proven invaluable. It has been through the feature productions that the outskirt houses in particular have been able to boost their admission prices and get their public accustomed to paying ten cents.

Four reels constitutes the average show in this city, with a change of program daily. The rental price for service has increased, and exchange men say that the increased cost of production has been the reason for it.

With a few exceptions the exhibitors make no complaint over this increase, feeling that it is justified as long as the quality of their program has increased, making it possible for them to make a stronger bid for patronage to offset the added expense.

The chief complaint the exhibitor has against the film is the padding now so much the custom among the manufacturers. Many of the exhibitors complain that a four-reel production will not hold the audience, as it is usually a two-reel production padded into four.

The drama, social and classic as well as comedy, has the

call in this vicinity. Most of the exhibitors are of the opinion that the serial picture has lost its novelty and bores rather than appeals to their patrons.

J. W. MARTIN.

Lack of Harmony in Program Management, Say Billings Managers

Special to MOTION PICTURE NEWS

Billings, Mont., Oct. 19.

EXHIBITORS agree that, generally speaking, their houses are constantly drawing a better class of patronage. As details of plot, staging, acting and photography are developed to their highest perfection, the more intelligent and educated classes of people become interested, and exhibitors believe that the art of producing photoplays has advanced to such an extent that the poorer and cheaper productions are bound to be discarded.

People have learned to discriminate and judge the plays according to their true value, they say, and nothing but the best finds favor.

Admission prices for regular programs have not advanced, though all-feature theatres are charging fifteen cents as against ten cents for the other houses. Efforts made to raise the admission above these figures for unusual features have met with failure, as a sliding scale is held in great disfavor by the public.

A regular advance meets with no opposition if the product comes up to standard, but the admission, whether high or low, must remain fixed.

Feature productions rent for more now than formerly, and exhibitors here feel that the town is rated too high. From lack of union and co-operation, however, they have been unable to secure any reduction.

Classic drama and educational features appeal alike to men and women, but Montana exhibitors have found that comedy finds favor with a much larger percentage of men than women. Men especially enjoy laugh-producing pictures.

The European war has affected the attendance in motion picture houses very little. It is affecting exhibitors, however, for carbons, which are manufactured in Germany, are becoming scarce.

Serial pictures, especially those with an involved and long drawn-out plot, are falling into disfavor. The serial that is to receive the favor of the public in the future will be the one that makes each reel complete in itself, though showing the same actors in different plots. Such is the opinion heard here.

One exhibitor has adopted the plan of sending out simple and attractive announcement cards. Persons receiving these feel sure something unusually worth while is being offered and respond accordingly.

Newspaper advertising has come to be the principle medium of the man who watches for leaks, and strives to eliminate them. With these simple means of advertising, coupled with good music, clean, comfortable and well ventilated houses, local exhibitors draw capacity houses.

Signs of the times apparently indicate that the password in the motion picture business, as well as other lines, is "advance." The man with the small theatre will have small chance in the future. He will be crowded out by his competitors with more life and initiative. The small, close house, with its old projectors and cracked and soiled screens, cannot hope to successfully compete with houses which offer more modern conveniences and accessories for the comfort and pleasure of its patrons.

The old cry of insufficient diversity and lack of harmony in the arrangement of programs is also raised, as it has been raised by exhibitors throughout the country since the motion picture business attained large proportions and exhibitors began to study their requirements.

As the men at the other end of the line become more familiar with the needs of the exhibitor, the latter hopes this complaint will automatically adjust itself. Some of the exhibitors do think, however, that—to be decent about it—a woeful lack of judgment is often shown in grouping

plays sent out. This criticism, as all others, is offered for what it is worth—bread cast upon the waters or a pebble cast into the sea, according to the point of view.

T. A. HUNTLEY.

Butte Feels Depression Less Than Any Other City

Special to MOTION PICTURE NEWS

Butte, Mont., Oct. 19.

IN Montana the advance in the motion picture business has gone ahead during the past year with the same rapid development which marked the resources of the great commonwealth. In the various small towns that mushroom like have sprung up in the different sections, small picture theatres have arisen to answer the demand by the settlers for a little entertainment.

The admission continued to be but ten cents until about a year ago. It was then that the demand of the patrons for larger shows, for more features, for vaudeville in addition to the pictures, for orchestras of more than two or three pieces and for generally as much comfort as was to be found in the big opera houses, told the managers that it would be impossible to continue on a ten-cent admission basis.

The situation was easily remedied.

The prices were raised to 15 cents and at that standard they have remained. It is very seldom that the price has been advanced even for a big attraction. In fact, in the past year there has been no record of any of the theatres advancing, regardless of the size of the extra attraction. The 15-cent admission at first was a little distasteful, but very soon the people became accustomed to the idea.

The quality of the shows was increased and every one is satisfied at the present time.

In common with the rest of the country, Butte as well as the other towns of the state, there has been a big demand for features and the people are willing to pay for them.

All sections of motion picture work are represented at the Butte theatres and, judging from the patronage, all are liked. The Butte theatres accommodate from 1,200 to 500 each at a sitting and the shows run in the afternoon and evening. The change of mining shifts makes the afternoons as important as the nights. Butte has as many men working at night in the mines as in the daytime and hence the matinees are very popular, especially so amongst the single men who happen to be on night duty. Nowhere else, probably, are they so well attended.

Even under the depressing conditions—which perhaps have affected Butte less than most towns in the United States as a result of the war conditions in Europe and the general decline through the country—the attendance at the

theatres has abated little. Managers are not kicking. Their advertisements are as big and as boasting as ever and the crowds are as long and as wide as at any time before.

If the succeeding year brings as much to the motion picture business in Butte and in Montana generally as the past year has, the managers will have little cause for complaint.

JAMES CUMMINS.

Boise Exhibitors Express Different Views Regarding Features

Special to MOTION PICTURE NEWS

Boise, Idaho, Oct. 19.

THAT the motion picture films are of a higher quality than formerly and have gradually grown better from year to year, thus commanding a much better class of patronage, while prices have not generally advanced, except on special features, is shown by interviews with the proprietors of the five motion picture show managers of Boise.

Business conditions are fairly good here, but little complaint is made by exhibitors, and while competition is keen, the houses generally are doing a good business, and as the programs are so many and varied that the public has an unlimited choice, and it is not unusual to find one theatre party taking in from one to three shows a night and thinking nothing of it.

There is a wide difference of opinion among managers as to the most attractive program, some believe the special feature programs are the best business getters, while others like a varied program and believe they are most desired by the public.

One exhibitor is strong in his opinion that the exhibitors should do business direct with the manufacturers and eliminate the exchange man. His reasons for making such changes are that the exchange men try to do business on a limited number of reels, thus not being able to supply all the territory and that the films often arrive in bad condition, whereas if exhibitors were dealing direct with manufacturers, a greater number of reels would be manufactured, they would be delivered in better condition and reels containing certain pictures in demand could be secured on short notice instead of being obliged to wait from twenty to sixty days for a film and then get one which will not command transient trade because it has been over such a vast territory that many have already witnessed it.

Business conditions are improving, notwithstanding two additional houses have been added here since May, with a seating capacity of some 1,300.

J. N. FLOYD.

COAST CITIES REPORT PROSPERITY

Special to MOTION PICTURE NEWS

Los Angeles, Oct. 19.

SOUTHERN California motion picture exhibitors are, generally speaking, pessimistic concerning business at present, but very optimistic regarding the future. Summer business is never as good here as in the winter, as the population during the fall, winter and spring months is much greater, due to the tourists and the thousands who come here to spend the winter. To a more or less extent Los Angeles is a tourist city, and the absence of the people during the summer and early fall is keenly felt by the motion picture men.

The exhibitors are receiving patronage from all classes of people, and especially is this true of the higher-priced downtown houses. It is as common to see the curbs in front of straight motion picture theatres lined with automobiles. The general trend is toward higher prices, and of the downtown theatres a very large per cent. charge ten cents and more.

For a time there was but one five-cent house on Broadway, the principal retail street, and now there are but two.

About half of the retail district theatres run feature pictures exclusively, and at the suburban houses features are used one, two and in some instances three nights each week. A small number of theatres have discontinued the use of big productions altogether.

Rentals have decreased with regard to both feature and mixed program ranging from 10 to 50 per cent., according to the quality of the pictures.

This is due partially to keen competition here because of the number of exchanges and feature houses, and partially to the failure of the smaller exhibitor to use the features at a profit at the former prices. In the city none of the houses charge a greater admission fee when feature pictures are shown, but this is not true in the smaller cities.

Exchanges giving a complete mixed service make quotations

on a basis of four reels per week, changed as the exhibitors desire.

More complaint is heard concerning western dramas than other classes of photoplays. The exhibitors believe too many of this character, practically all of which are overdrawn, have been made, and the public has grown tired of the posse, cowboy pastime, bunk-house scenes and gun play. "To put up a piece of western paper," one exhibitor remarked the other day, "is just like inviting all my patrons to stay away."

"Padding" is an overworked word of the exhibitor's vocabulary just now. Many complaints are made regarding insufficient action for the footage, and the producer's failure to cut the scenes when the desired action is completed. Poor stories, unattractive titles and sensational paper are other causes for criticism.

Retail district theatres have found the serial pictures do not draw well, while the suburban and small city theatre men find them excellent business getters. This condition has been attributed to the fact that people were glad to go a short distance to see such a picture, but did not consider them worth a special trip down to the retail district.

There is a spirit of dissatisfaction among the suburban exhibitors of Los Angeles. Primarily they are unable to get a service which is exclusive for their district and is not shown in retail section theatres. Quietly a number have been organizing for the purpose of renting the first three or four weeks' service of several films. Their plan is to alternate the first, second, third and fourth week service among themselves, and all pay an equal portion of the rentals. So far they have not been able to induce an exchange to rent them a service in this manner.

The manager of one of the principal exchanges, who asked that he be not quoted, made the assertion that nine out of every ten exhibitors were demanding lower rental rates. "The prices now," the exchangeman continued, "are far less than ever before, and we are down to the bottom." The cause of the complaints is based upon poor business in the suburban theatres, due largely, it is believed, to there being more theatres than the field warrants. The picture theatres of this city will average 600 seats each, and there is one for every 4,500 population. In addition to these, there are a number of vaudeville and legitimate houses, and Los Angeles is a summer town the year round, with many parks, beaches and similar attractions.

No complaint is to be heard regarding the municipal censor board, nor the city license; there is no legislation of an injurious nature pending, and exhibitors have been successful in preventing passage of an ordinance providing that only licensed operators, more than twenty-one years of age, who have passed the examination given by the city electrician, be allowed in the projecting booth.

Exhibitors have given little attention to the matter of organization. Most of the owners of the larger theatres of the retail district are members of the Theatre Managers' Association, affiliated with a national organization, and there are not to exceed twelve or fifteen members of the local Exhibitors' League now in good standing. Generally speaking, there is no co-operation between managers here. Each exhibitor is fighting his own battles separately.

Exhibitors of the smaller houses and those in the suburbs are returning to the regular program. One exchange with such service has increased its business fully 30 per cent. in the past sixty days. Another has added a number of houses, and exchange men in charge of regular programs believe exhibitors will discontinue the poor quality features altogether.

From estimates made by exchange men, fully half of the theatres are not at this time paying a profit in keeping with the investments. Since 1912 there has been a gradual decline in business, due partially to the general financial stringency the country over, and in a greater extent to the over-abundance of theatres here.

The European war, causing a sudden tightening, made this decrease in business acute. Coming as it did at a time when people were becoming optimistic regarding economic conditions, it caused all to retrench and prepare for a future by a general tightening of the purse strings. The places of amusement were the first to feel this condition.

One change that will probably take place here in the near future is that with regard to changing programs daily. The retail district theatres using regular programs change twice weekly, and the suburban houses three and four times. Already many—fully thirty per cent.—of the suburban houses are now changing daily, and it is believed this will become universal.

All over the West men of all lines of business believe the fall and winter of 1914 and the year of 1915 will be the greatest in the history of California. All are expecting an era of prosperity because they believe the people are coming.

If the prophecy proves true—and there is no reason to doubt that it will—the motion picture theatre men will be greatly benefited. Railroads have arranged that all tickets to San Francisco and San Diego expositions will be the same price to any point in California, and the stop-over limits will be greatly lengthened, which will prove a great inducement to people to visit Southern California if they attend the Panama Exposition.

J. C. JESSEN.

Films Based on Dramatic Successes Lead in Spokane Photoplay Theatres

Special to MOTION PICTURE NEWS

Spokane, Oct. 19.

TWO big theatres, among the finest in Spokane, which could not have qualified as picture houses last May, now are drawing heavy patronage with their films. The Empress, former home of Sullivan and Considine vaudeville, has been taken over by Sam W. B. Cohn as a feature film house, and the change of policy at the old Orpheum, now Loew's, which has added five reels of film to each program, now puts that theatre practically into the film ranks.

None of the picture houses then operating has left the field. The American, the largest picture theatre in the city, has changed management and is doing larger business than at the time of the previous market report.

The Casino, Clem, Lyric, Majestic, Best, Rex and Cineograph among the other downtown houses, and the picture theatres in the outlying sections of the city, are operating under favorable circumstances.

Undoubtedly a better class of patronage is being drawn to the picture theatres. The long lines of automobiles standing nightly in front of the film houses is one of the plain indications of this. Again, there is slightly less competition from the legitimate and variety houses, the withdrawal of the Orpheum Circuit from the Northwest being a factor beneficial to the film men.

Admission prices are practically the same as they have been. The best of the feature services are tied up on permanent contracts.

Features, as a general rule, have been of most value to exhibitors whose houses are furthest from the heart of the downtown district and who have succeeded in making patrons walk a block or two further to see a particular film than they would to see routine pictures. At present, the houses closest downtown are too small to make feature pictures profitable, for the reason that they have to give more shows per day and must curtail their programs.

There is no agreement among the theatre managers as to what sort of film is the most valuable, and the choice varies with the houses. The news weeklies are considered valuable assets, but educational films are in no demand except as fillers. Comedies of the slap-stick school are wanted only in the cheaper houses. "Blood and thunder" is waning in popularity, and at least two houses which have specialized in it are trying to work out a change.

Dramatic productions, particularly those which have important names in their casts, have proved altogether the best investment.

The theatres are learning that it is hard to sustain interest in the moving picture serials unless the stories are run concurrently in the newspapers, and the latter are beginning to be scary of the idea.

JAN DRUMMOND.

(Continued on page 59.)

ANIMATED WEEKLY HAS WORLD'S SERIES

Through careful planning and clever manipulation, Editor Jack Cohn and Cameraman U. K. Whipple, of the Universal Animated Weekly, were the only ones able to secure pictures of the world's series inside the grounds, it is said.

Cohn and Whipple left the offices of the Animated Weekly and, accompanied by other cameramen, boarded a train bound for Philadelphia. On the way down many discussions arose as to the chances for getting into the grounds, and all voted it would be impossible.

The editor and his cameraman hurried over to Shibe Park, where they separated from the rest of the cameramen, who had given up the thought of getting inside the park, and contented themselves with taking pictures of the crowds outside.

Editor Cohn's plans worked out successfully, for within half an hour he and Whipple had the camera set up on the diamond behind third base, and were busy grinding out foot after foot of film of what is said to be the greatest baseball film ever taken.

HIGH PRAISE FOR "SALOMY JANE"

A private exhibition of "Salomy Jane," the Alco release from the cameras of the California Motion Picture Corporation, was given in the releasing corporation's projection room last week.

Many prominent film men expressed admiration, as the scenes of the Bret Harte romance were spread before them. Particularly were the directors of the California organization pleased, for the projection meant the end of two years' work in California.

SELLS WESTERN STATE RIGHTS FOR "CRUSADERS"

Special to MOTION PICTURE NEWS

Los Angeles, Oct. 20.

The Italian film, "Crusaders," has been sold to Charles Marley for state rights in California, Arizona and Nevada. Although this picture was made more than a year ago, it has never been shown in any of these states, and judging from the success it has had, Mr. Marley believes he will experience no difficulty in making steady booking.

BEHREND SLIDES HAVE MANY GOOD POINTS

The Behrend Motion Picture Supply House, New York City, is manufacturing a line of unbreakable, unburnable, uncrackable brass slides, which gives the average exhibitor an indestructible article.

The line is obtainable at all branches of the General Film Company, Mutual Film Corporation and a majority of dealers throughout the United States and Canada.

John Barrymore in "Legitimate" Laugh-Maker

"The Man From Mexico," Remembered for Its Phenomenal Run Some Years Ago, Now in Famous Players Film on Paramount Program

JOHN BARRYMORE, who made his first appearance in motion pictures a few months ago, when he was starred in the Famous Players comedy production, "An American Citizen," returns to the screen in a second Famous Players—Paramount release, H. A. Du Souchet's comedy triumph, "The Man From Mexico."

month, but at the expiration of his sentence he returns home to find that his wife has, during his absence, diligently studied and mastered the habits and language of Mexico—of which Fitzhew knows nothing. All his former troubles pale into insignificance beside the great dilemma he now finds himself in, and his desperate and frenzied attempts to



JACK BARRYMORE IN "THE MAN FROM MEXICO"
(Famous Players—Paramount Feature)

The situations are just the kind that afford the star ample opportunities for the display of his droll mannerisms, and delightful, mirth-provoking pranks.

"The Man From Mexico" has been recorded in theatrical history as one of the greatest comedies of the past two decades. The humorous incidents occur so rapidly that there is scarcely a pause of laughter throughout the entire production. In the film version the plot is greatly amplified, and many laughable situations that were only referred to in the original production are incorporated in the film, with the result that the motion picture production surpasses the stage version in humor and appeal.

The character is a light-headed and light-hearted, bibulous gentleman, named Fitzhew. Fitzhew gets into and out of more difficulties than can be enumerated. Fitzhew prides himself on a talent for lying, but attains the masterpiece of mendacity when he is called upon to explain to his wife the reason for a necessary absence of thirty days—necessary because he has been sentenced to the island for that period of time for disorderly conduct. Fitzhew invents a story to the effect that he is compelled to go to Mexico on business for a

explain matters to his puzzled wife provide a series of laugh-provoking incidents rarely equalled, in number and degree, in a film comedy.

The production, which is in five parts, will be released on the Paramount program November 2.

OLD NEW YORK IN NEW WORLD FILM PLAY

Barbara Tennant, the well-known motion picture star, who has recently been seen in the William A. Brady feature, "The Dollar Mark," is making her appearance in the Shubert feature that the World Film Corporation is releasing, "When Broadway Was a Trail," the work of O. A. C. Lund.

Not only has Mr. Lund produced the photo-play, but he also played the part of Henry Minuet, the son of the Dutch governor of New Amsterdam. The early days in America's colonizing period are shown.

The picture is unique, in that it contrasts the community of New Amsterdam and the Puritan settlement of Danvers, which is today known as Salem, Mass., while New Amsterdam is the basis for the present-day New York.

LIVE WIRE EXHIBITORS

EDITOR'S NOTE.—It is the desire of "The Motion Picture News" to include under this heading novel advertising ideas, successful schemes in the management, decoration and equipment of the theatre—everything, in fact, done by the exhibitor to stimulate his trade. We invite every exhibitor to write us about any new enterprise he has; also to come to us for advice or information along any line. Address: Editor, "The Motion Picture News," 220 West Forty-second Street, New York City

"LET THE PATRON OWN THE THEATRE"

"If you don't like good motion pictures yourself, keep out of the motion picture business," is John C. Karlsen's advice to the man who is seeking to please his trade. "If you do like them, get films that you really enjoy, and the chances are that your patrons will like them."

Karlsen is manager of the Garrick Theatre, 2541 Nicolet avenue, Minneapolis, Minn., in the heart of an exclusive residence section of the city.

Mr. Karlsen further believes in the use of neat, inexpensive programs, to keep his patrons informed. For instance, his program just issued announced the Famous Players star features seven weeks ahead. These will be run every Tuesday. He begins with Mary Pickford in "Caprice," and the series will run indefinitely. He also announces the "Trey o' Hearts" on Friday and Saturday, and the "Lucille Love" series on Monday nights.

There are more than a dozen homes of millionaires within six blocks of this theatre, and there are laborers' homes within the same radius. He has found that the occupants of the marble homes enjoy melodramas occasionally, and that the men who tin roofs, shovel coal and deliver groceries appreciate such plays as "The Bishop's Carriage," mixed in with their comedy and melodrama.

The program at the Garrick is well-balanced, and that is why it plays up-to-date films as early as the bigger theatres.

"Those girls act as though they own the place," a man said to Karlsen when twenty students from an exclusive girls' school went to the door and asked if they could have twenty seats together.

"They do own it, along with the other people of the district, and I am running it for them," he said. "I have the seats for them, for they usually come on Tuesdays."

If acting as though one owns a theatre is a fault, Karlsen certainly encourages the fault. The theatre is fitted as comfortably as a home, and the patrons feel at home. They mention a film they would like to see and they see it. All this is done by being neighborly, and

MATINEES FOR THE SCHOOL CHILDREN

MANAGER GEORGE W. ERDMANN, of the Elmwood Theatre, Buffalo, N. Y., which is located in the heart of the west side school district, has inaugurated a series of "student matinees" on Saturday afternoons during the fall and winter. Realizing the great educative value of the films, especially in supplementing the various courses being pursued in the public and high schools, Manager Erdmann has seen an opportunity.

In an effort to make this opportunity a realization, he has booked a long list of educational pictures covering travel, science and literary subjects. The first feature, presented on Saturday, September 26, was Charles Dickens' "The Chimes," which many of the local high school students study in their English literature classes. In order that students may know what is to be shown every Saturday afternoon, letters are written to each of the principals in the Elmwood district, informing them of the list, with the request that the letter be placed upon the bulletin board where the students may see it.

In his first letter, informing the teachers and principals of his "student matinees," Manager Erdmann requested that the teachers send in subjects which they would like to have their pupils see on the screen, and the management, in so far as it is possible, will try to procure the subject. All the principals and teachers were sent invitations to be on hand at the first of the series.

During the fall and winter, Mr. Erdmann will attend the different schools on the west side and give short talks on the educative value of the motion picture and show the pupils wherein they may profit by attending good theatres and viewing the many educational films now being manufactured.

On these afternoons, all children under 16 years of age, when accompanied

A LIVE-WIRE PHOTOPLAYHOUSE

Here good projection holds sway over well pleased people in a house that is a model of good taste



Ventilation is a second hobby of the head of this up to date house and it means success

THE APOLLO THEATRE, PEORIA, ILL.

by running five reels at a show with five changes of program weekly.

ALL ELSIE ESMOND FILMS FOR ALBANY

OWING to the fact that Elsie Esmond in "On the Border Line" has filled the Hudson theatre, Albany, N. Y., on two occasions, Manager Roberts has contracted for all the films in which that young woman is starred.

Miss Esmond was featured for a season with the Bert Lytell stock company in Albany, and she became a big favorite. Mr. Roberts is to be congratulated for his efforts to secure what Albanians want, and his efforts will meet with appreciation.

by their parents or guardians, will be admitted at 5 cents. On all other occasions, only children under ten years are admitted at this price.

It is thought that this lowering of the admission price will bring a larger number of child patrons on these afternoons. Parents will be urged to send their children to these matinees and they will be assured that all subjects shown will be perfectly safe in every way.

This is one thing on which Mr. Erdmann is always very careful and he needs must be in his district. No objectionable film is ever allowed to creep into the Elmwood programs.

As yet, Mr. Erdmann has had no replies to his letters, but a few phone calls from some of the principals have greatly encouraged him in his efforts, as these few were all enthusiastic over the idea and offered Mr. Erdmann their assistance in every way possible.

If a pupil can see the subject which he or she is studying, much greater interest will be aroused in the school work. The music program will not be overlooked on these "student matinees," as Mr. Erdmann will select each week a number of examples from the different masters, which will represent their best effort. These selections will be played by the Elmwood orchestra and organ. Mr. Erdmann is very optimistic about the idea.

BOOSTING PRICES WITH TIMELY ADVERTISING

THE advertising stunts resorted to by the exhibitors of "Les Miserables" at Convention Hall to advertise their film proved successful. The special attraction did good business throughout the week, despite weather which was very unfavorable for motion pictures.

N. H. Gordon, of Boston, has the State rights to the picture, and when he prepared to put it in here, he instructed his manager to provide for a free exhibition for the clergy of the city, the educators, members of the Rochester Ad. Club, business men and others. This was given the Friday night previous to the opening, and was well attended.

When the regular engagement opened there was much interest in the film, and good business was done during the week, and this in spite of the fact that the prices were higher than any ever asked here, from 25 to 50 cents.

BLOTTERS FOR "KIDDIES"

MANAGER FRED SIEGERT of the Columbia Theatre, with four hundred seats, at West Jefferson street and Arlington avenue, Los Angeles, is getting patronage from school children by distributing blotters each week, upon which the program for the week is printed.

The theatre is located very advantageously for this, being about in the center of three schools. In addition to supplying school children, Mr. Siegert sees to it that all stores, offices and stationery stores receive generous amounts.

First Lasky-Belasco Picture Completed

"Rose of the Rancho" Reveals New Departures in Artistic Effect and Realistic Settings in Land of the Golden West

IN the production of the "Rose of the Rancho," the first of the Belasco productions to be released by the Jesse L. Lasky Feature Play Company, and in which a complete Belasco cast is being used, the Lasky company have gone to extremes to make this production the most artistic that concern has yet turned out.

Two reels of the picture were re-taken in order to introduce therein a Spanish saddle which was discovered shortly after the first part of the picture had been finished, and in order to gain the atmospheric detail that this saddle would lend the picture, Mr. De Mille retook the first two thousand feet.

By making a monetary donation to the mission of San Fernando at Monterey,



JUANITA KEEPS HER LOVER AT A DISTANCE

Mr. De Mille was allowed to use the mission grounds, and many of the scenes are laid in the historic old buildings throughout the vast acreage fronting the mission house.

An exact replica of the Castro Rancho was built on the new Lasky ranch as was also a duplicate, in appearance, of the old Spanish custom house, both of which are to be destroyed in the final scenes of the "Rose of the Rancho."

Cecil B. De Mille and Wilfred Buckland made a trip to Guadlajajara, Mexico, and there engaged forty native actors to appear in the roles of Vaqueros, Caballeros and Mexican Indians, and prevailed upon the Mexicans to bring their native costumes and characteristic mantillas and multi-colored gowns.

Padre Francisca de la Dianna, head of the Monterey mission, consented to appear in the picture, and actually performed the mock ceremony between Bessie Barriscale as the "Rose" and Monroe Salisbury as the "Gringo."

Richard Walton Tully, co-author of the play, assisted in the production, while Cecil B. De Mille and Wilfred Buckland handled the staging of the piece.

It will be released November 16 and shown at the Strand Theatre for the



JUANITA AGREES TO THE BETROTHAL

first time, when the Strand Theatre management will be the hosts to David Belasco, Jesse Lasky and Samuel Goldfish, the three men who are associated in the Lasky-Belasco productions.

ATTRACTIVE LOBBY FRAMES DRAW PATRONAGE

Nothing advertises a theatre more than its outward appearance. The lobby which is neat and decorated attractively with the best of lobby display frames filled with high-class posters or sheets and photographs will attract the patrons. This is nothing but human nature, for we all like cleanliness and are attracted by it.

William Fox, in his chain of houses, is putting this into practice by establishing uniform single sheet frames. The color is Pompeian red with gold trimmings. These particular frames are being turned out as fast as possible by Menger & Ring, of New York.

GOOD BUSINESS FOR "AFTER THE BALL"

S. N. Silberman, of the Photo Drama Company, New York, has returned from a very successful trip through Wisconsin and upper Michigan, and reports that he has \$6,000 worth of advanced booking on "After the Ball." The war does not seem to affect this feature, and "After the Ball" is playing capacity business wherever shown.

Mr. Silberman is making his headquarters at 401 Manhattan Building, Milwaukee, Wisconsin.

AMONG THE EXCHANGES

LOS ANGELES WILL HAVE THREE NEW EXCHANGES

LOS Angeles is to have three new film exchanges within the next week or two, one that will handle the Alco program, one for the Box Office Attraction pictures, and a branch of the Nat A. Magnar Feature Service.

The Magnar office will be located in the Superba Theatre building, 520 South Broadway, and will be in charge of H. E. White, who was formerly connected with the local Golden Gate Film Exchange. The company is composed of Nat. A. Magnar, formerly connected with Kolb & Dill, one of the leading theatrical producing firms of the West Coast, and Charles B. Kavanaugh, former business manager of Ferris Hartman. They have the state rights for "Neptune's Daughter," "Strangers of Paris," "House of Bondage," and a number of other pictures.

Sol Lesser, president of the Golden Gate Film Exchange, Inc., with main office at San Francisco and branches in all the principal western cities, has been in Los Angeles making arrangements for opening another exchange there for handling the Alco feature program. Mr. Lesser has contracted for this service for California, Arizona and Nevada and will maintain separate exchanges in both Los Angeles and at San Francisco.

Harry C. Drumm, West Coast district manager of the World Film Corporation exchanges, stopped off in Los Angeles, after a trip from Seattle. He found that cities in the north had suffered from a slight business depression but that business now is normal.

"There seemed to be a wave of prosperity coming south for the exhibitors," he explained. "When I visited Seattle, the theatre men there told me they had experienced a few dull weeks, but with the arrival of cooler weather attendance at the theatres increased. As I came down the coast I heard the same story at practically every city. Now in Los Angeles the house managers tell me conditions are better than they were last week.

The poor business on the coast, I am certain, is over now and conditions will continue to improve."

PARAMOUNT INVADES CAPITAL

THE Paramount program is now an established fact in Washington, D. C., under the caption of The Famous Players Exchange. Offices have been secured in the Second National Bank building with Geo. M. Mann as manager.

"We are not hurrying to place our films in Washington theatres," commented Mr. Mann, "because it is our desire to have the Paramount program run exclusively in at least one theatre here. We have many requests for individual plays from the local houses, but it is not exactly in accordance with our policy to offer our productions in that manner. In my survey of the field, our Washington office promises advantageous. We anticipate shortly to establish the Paramount program in one of the large theatres."

Mr. Mann comes from Philadelphia, where he was associated with the Stanley Company. He is well known in the motion picture and theatrical business.

LICHTMAN AND KANE TOUR ALCO EXCHANGES

AL. LICHTMAN, vice-president and general manager of the Alco Film Corporation, and Robert T. Kane, president of the allied Atsco, are making a tour of inspection of the organization's eastern and western exchanges. Mr. Kane began his inspection in Minneapolis. He reports that he found a steady demand for the Alco releases and for the Radium Gold Fibre screen. He will visit in turn all of the corporation's western exchanges, while Mr. Lichtman visits the eastern organizations, returning to New York at frequent intervals.

BOX OFFICE FLOURISHES IN PITTSBURGH

MANAGER HARRY B. DAY, of the Box Office Attractions Company, in Pittsburgh, is pleased with the amount of business his company has been doing in that section. He stated the patrons of the company are on the increase, and he is being kept busy with bookings on all of his big features. He also states his efforts in building up the Fox program has met with the biggest kind of success, and he is running them in many of the Pittsburgh and out of town theatres, with inquiries coming in from all over his district.

UNIVERSAL, MILWAUKEE, SPREADS OUT INTO LARGER QUARTERS

THE Milwaukee branch of the Universal Film Company has enlarged its quarters in the Manhattan Building. It now occupies the entire front of the second floor.

These new quarters will give them a large, light and airy fireproof inspection room, a big vault for the storage of

films, a new stock room, and considerable more office room. Manager W. C. Brimmer reports that business is increasing every day, and that the new quarters will give them splendid facilities for handling the volume of business.

Old Faces in New Places

S. BARRETT McCORMICK has taken the feature management of the Mutual Film Company in Denver and Denham Palmer the same position with the General Film Company. Both young men are enterprising, versed thoroughly in the motion picture business, and immensely popular with their respective trades.

Mr. McCormick is something of a motion picture expert, having been interested in the game almost since its start and having had success as a scenario author.

Mr. Palmer has been with the General Film Company a year in Denver and had much experience in the game in the East. He succeeds W. W. Drum, who has gone to Seattle, Wash., to take a position with the World Film Company.

Changes In St. Louis

Charles Werner has been appointed manager of the World's Features Exchange in St. Louis. Mr. Werner declares he is working sixteen hours a day, and then cannot keep up with the rush. World's Features have recently acquired the Shubert and the Brady releases, and they are furnishing two new theatres with the features, the Lindell, Grand and Hebert street, and the West End Lyric, Delmar and Euclid avenues.

C. P. Cuff, former manager of World Features, is managing a theatre at Springfield, Mo.

Warner's Features Exchange, in the Benoist Building, St. Louis, has a new manager, Richard Broderick, who was exchange manager for the same company in Detroit. Warner's Features have also a new traveling representative, in the person of James Arnette, who was at one time an exhibitor in Oklahoma.

Joseph Weintraub, a traveling salesman for the Swanson-Crawford Film Company, St. Louis, reports doing good business during a recent trip in the outlying districts.

Klein Goes to Detroit

Joseph Klein, formerly of the Warner's of Atlanta Ga., has taken charge of the Detroit branch of the World Film Corporation, succeeding Mr. Dickenson. Mr. Klein has had a number of years of experience in the film game.

Four Oz Players Favorites With Public

Vivian Reed, Jane Urban, J. Farrell MacDonald and Violet Macmillan Make Hit With Thousands of Film Patrons

Special to MOTION PICTURE NEWS

Los Angeles, Oct. 19.

THE Oz Film Manufacturing Company has engaged four well known players whose acting in the company's productions has caused much favorable comment in film circles. Their work in different roles, calling forth all their histrionic powers, has placed them high in the estimate of screen critics and the public.

The first, Vivian Reed, became a screen actress almost unawares. She formerly posed for New York artists,

been in motion pictures, being at various times connected with the Imp, Ajax, Pathe Freres, Powers, Universal, Warner's Features and Oz Film Company in important positions.

Violet Macmillan first became prominent when she appeared in the leading role of Dorothy in the "Wizard of Oz" Company organized by Hurtig and Seamon.

She created the lead in "The Time, The Place and The Girl," and has been identified with musical comedy for a number of years with uniform success.

A CLUSTER OF OZ BRILLIANTS



VIOLET MACMILLAN

JANE URBAN

J. F. McDONALD

VIVIAN REED

and on a visit to California visited the Oz studio from curiosity to see how motion pictures were made.

Attracted by her beauty, Mr. Baum engaged her for a small part. In this small part she proved so graceful and attractive that she was cast in the next picture for a much more prominent role, and in the third picture she impersonated the principal character with distinction.

Jane Urban, another Oz player, is well known to the legitimate stage. For a number of years she has had leading parts in musical comedies and stock companies.

Miss Urban is a great favorite and her appearance in motion pictures will undoubtedly give her added prestige.

J. Farrell MacDonald has been well known to the theatrical world for over twenty-four years. He has played important leads with Robert Mantell, Nance O'Neil, Holbrook Blinn and others. He also played leads with Elitch Garden Stock Company, Denver; Poli Stock Company, in Springfield, Mass., and Crescent Stock Company, in Brooklyn, N. Y.

Mr. MacDonald also played for nine years in various operatic companies, including D'Oyly Carte Opera Company of London; Danville Opera Company in United Kingdom, and his own opera company in Canada.

For seven years Mr. MacDonald has

During the past year she was a headliner on the Orpheum circuit, when she was called "The Modern Cinderella" on account of her tiny feet and perfect figure.

FEATURES HANDLED DIRECT BY FILM COMPANY

That a good deal of confusion exists in the minds of the average exhibitor as to what pictures are being handled through the special feature department of the General Film Company and those booking direct through the various Kleine offices, is evidenced by the misdirected letters received by both concerns.

The special feature department of the General Film Company is handling "Anne Boleyn," "The Song of the Soul," "A Kingdom at Stake," "Othello," "The Secret of the Ring," "Vendetta," and "The Golden Beetle." Inquiries for those pictures should be addressed to the General Film Company.

The various Kleine offices are handling "Quo Vadis?," "The Last Days of Pompeii," "Antony and Cleopatra," "Between Savage and Tiger," "Spartacus," "The Lion of Venice," "European Armies in Action," and a number of two, three and four reel special releases.

DOROTHY DONNELLY IN FILM VERSION OF "THE THIEF"

Dorothy Donnelly, the creator of Madame X, has been engaged by the Box Office Attraction Company to play the star part in Henri Bernstein's play, "The Thief." Miss Donnelly will be supported by an all-star cast to include some of the most popular stock actors in the country. Miss Donnelly's emotional performance in Madame X kept the play on Broadway for two seasons.

"The Thief" was produced by Charles Frohman. The picture will be produced under the immediate direction of Edgar Lewis, producer of "Captain Swift" and other big features. Richard Buhler will play opposite Miss Donnelly.

"Zudora," Thanhouser Serial, Full of Realism

Director Makes Use of Miners in Explosion Scene—Court Room Episode Filmed in Historic Building

A CORPS of experienced miners, drillers and fire control men were utilized by Director Frederick Sullivan when taking the explosion scene in "Zudora," Thanhouser's new serial.

The title role, played by Marguerite Snow (Countess Olga in "The Million Dollar Mystery"), gains name from a mine owned by Zudora's father, in which he meets his death, the result of a premature blasting charge.

The run of pay ore has been suddenly increased, and in his exuberance, after years of patient prospecting, the father becomes over zealous and accidentally meets his death.

The astounding accuracy of this scene will hold spellbound all those who view it. It is a tragedy portrayal, which carries with it a living story of a life ambition frustrated.

The mine entrance with its patched beams, the building effort of one man "harried sore" is shown, and then the fateful events up to the final tragic

climax occur with telling effect.

It was because of the great danger in taking this scene that trained fire control men were employed.

Some of the most famous orators of a bygone day have declaimed within those musty old walls. Director Frederick Sullivan has carried onto the screen that attitude of mingled awe and expectancy which is typical of a court room throng.

In this scene, Harry Benham, who plays John Storm, the young sweetheart of Zudora, exacts a full measure of the opportunities afforded him, carrying along a breath-holding thrill to an unique climax.

ON TOUR FOR WORLD FILM

Joseph F. Partridge, acting as special representative for the World Film Corporation, is making a trip through western Canada in the interests of the concern. He will go as far as Vancouver on this tour.

REPEAL OF OHIO CENSOR LAW IN SIGHT

J. W. Binder, of the National Board, and Dr. Orrin G. Cocks, Advisory Secretary, Sound Sentiment in Tour of Buckeye State—Organization Has Plan to Establish Branches in All Cities for the Local Exercise of National Board's Functions

PRESENT indications point to the emancipation of exhibitors in Ohio from the bondage of legalized censorship. J. W. Binder, director of publicity and finance of the National Board of Censorship, who has just returned from a tour of that state with Dr. Orrin G. Cocks, advisory secretary of the board, made for the purpose of studying conditions at first hand, declares that public sentiment is so strong against the law and its unjust operations that it will in all probability be repealed at the next session of the Ohio legislature early in the year.

The National Board of Censorship has a plan for the adequate exercise of censorship to take the place of all official censor bodies, not only in Ohio, but throughout the country.

The new idea consists of making each city a unit body consisting of men and women in the community who shall serve without pay in the judgment of films in the same manner as the members of the National Board of Censorship.

Cities the Unit

As a result of the Ohio investigations the board will take charge of an active campaign to have the present law in that state repealed. Public opinion throughout the state will be created through the newspapers and trade journals. The board representing, as it does, the social service viewpoint, and being entirely unhampered and independent, is in a better position to make a winning fight than almost any other organization. The legalized censor board may object, but they cannot "disbar" the board from following its convictions through action in Ohio, nor visit "penalties" upon it.

"Legalized censorship of motion pictures in Ohio, we have reason to believe, will be repealed early in the new year after the legislature assembles," says J. W. Binder. "There is no sentiment in favor of it, either in official circles or among the thousands who patronize the motion picture shows. The bill out of which the law came was introduced at the request of one man—then, apparently, somewhat of a figure in the motion picture world—and since less important.

"At the hearings before the measure became a law there was no opposition from any source, and the bill became a law by negation rather than by affirmation. Under the operation of the law there are many complaints of unfairness, delays and annoyances.

"Exchangemen of both feature and regular releases speak of these things, but, pretty generally, will not allow themselves to be quoted for fear of the consequences that might be visited upon

their pictures if they told the facts. Sinister hints are made in connection with an enterprise to publish an Ohio motion picture paper to which manufacturers, exchangemen and others will be 'invited' to subscribe, and in which they will be asked to advertise.

No Attempt to Fix Standard

"The board makes no attempt to fix standards, or to advise manufacturers why their pictures have been rejected. The penal section of the act under which the board operates has been defied and declared invalid by one of the courts of Ohio. This allows exhibitors to run films that have been censored without the official "leader" on which the board's approval is registered.

"The above are a few of the conditions which our investigations of censor conditions in Ohio discovered. Dr. Orrin G. Cocks, advisory secretary of the board, and I made a tour of the

principal cities of Ohio and talked with leading officials of the state and cities, as well as with exchangemen, feature men, exhibitors and others. Our object was to determine for ourselves, at first hand, what the facts were.

"We found that while the facts of the actual working of official censorship were as above stated, that in almost every case where the constructive, time-tried plan of the National Board was explained making the city the unit, and having a committee of unpaid men and women of the same caliber as the personnel of the National Board, confining its activities largely to those pictures, less than five per cent. of the entire output, which are not seen by the National Board, was explained it was received as a sane, conservative plan, and the board was assured of the hearty co-operation in putting the plan through of the men who have the power to make it a success."

300-Foot Drop Provides Impromptu Thrills

Reckless Cowboy Gallop, Almost Fatal, Ends in Fall Over Cliff and Is Caught by Alert New York Motion Camera Man

ALERTNESS of a motion picture camera man is a quality that is demanded for the success of almost any film production, and on that account little wonder is expressed at a

York Motion Picture Corporation, that undoubtedly will go down in the annals of motion picture photography as one of the most remarkable since the birth of the industry.

It was an accident that for its seemingly inevitable fatal consequences has been unequalled, and was very fortunately filmed during the production of Mr. Ince's "The Two-Gun Man," a seven reel feature in which W. S. Hart is presented.

It was during the taking of a wild ride by a cowboy on horseback that the mishap occurred. Astride a beautiful black charger the cowboy galloped along the ridge of a range running parallel with the ocean shore. At the base of the cliff stood the camera man, recording every step taken by the steed and its rider. For half a mile the cowboy rode, when suddenly the animal dashed directly into a hole.

The abrupt stop sent the horse and rider crashing to the ground. But the momentum had been too great to permit of a safe landing. The cowboy and his steed toppled over the edge of the cliff and started to roll to the bottom.

For a distance of more than 300 feet the horse and cowboy rolled, and their miraculous escape from death was learned when they stood upon their feet practically unscathed. A few scratches and a bruise or two were dressed, and both returned to the action of the picture.



WILLIAM S. HART

majority of the thrilling actions that are caught by lenses.

But an accident was "shot" recently by one of the expert camera men employed by Thomas H. Ince, of the New

Kinetophote Announces New Features

Political Picture, "The Coming Power," Will Be the First, Followed by a Feature Based on Metropolitan Life—K. C. Booking Company, Inc., Established to Handle Concern's Output, with Ira H. Simmons as General Manager

READY to book the features of the Kinetophote Corporation as well as other multiples which are already controlled by that organization, the K. C. Booking Company, Inc., has established offices at 126 West Forty-sixth street, in the offices of the Kinetophote, with Ira H. Simmons as general manager.

Mr. Simmons has retired from the Montgomery-Simmons Film Service, Inc., in which film he was a big factor.

The offices of the Kinetophote have been busy preparing for the early re-



IRA H. SIMMONS

lease and booking of two features of a timely nature which will be put on the market in a short time.

The first, of special interest at this period of the year, when things political loom on the horizon, is "The Coming Power," a strong story of political intrigue and the triumph of right over the forces of corruption. The tale is told by Catherine Carr in three reels of swiftly moving action and was written from a script submitted to the Kinetophote by Raymond C. Hill.

Cast Is Carefully Selected

Contrary to what is often found in films of political stories, each character in "The Coming Power" has been chosen to fit the part. The part of the young radical is taken by Lionel Adams, who starred on the stage in "The Man of the Hour." For the character of the money king and boss of lesser politicians, William Crimmins, who played last winter in "At Bay," was chosen. Edith Lockett, who is playing the lead with Chauncey Olcott this year, and Annette Rose, whose work in "The

Spirit of the Poppy" and other big feature films has caused much enviable comment, divide honors in the roles assigned to the gentler sex. The cast also includes William Phillips and Leonard Grover, who were chosen from many screen actors who were considered for their parts.

"The Little Jewess" is the second early release planned by the Kinetophote, with Annette Rose in the leading character, and such persons in the cast as Edith Lockett, Sonia Mossell, Edward Mackay, Charles Lytton and Cochrane Bayly.

"Markia" Wins Wide Success

"The Little Jewess" is a story of New York life, prefaced by the scattering of the members of an immigrant family in their rescue from shipwreck. Strong characterization marks this work of Catherine Carr, who wrote it from the central idea of a script by Walba Waldo.

The Kinetophote reports a big success with "Markia, or The Destruction

of Carthage," which was reviewed in MOTION PICTURE NEWS a few weeks ago. This story of barbaric warfare, as exemplified in the third Punic war, seems to have caught on with exhibitors everywhere. The contrast between the scenes in this picture and those now being enacted in Europe make a lesson in history which the managers of motion picture theatres evidently believe will be of interest to their public.

"The Spirit of the Poppy," one of the biggest things the Kinetophote has done, is finding favor with exhibitors who have seen the film. They are all grasping the lesson taught by this dramatic story of the heroin traffic in New York, and appreciate the purpose through which it was written.

The K. C. Booking Company, Inc., is setting great store by "The Span of Life," in which Lionel Barrymore is featured. The film is about finished and should attract thousands of old theatre-goers, since turned film fans, who remember the stage production of Sutton Vane's famous old melodrama.

Oriental Glamour Marks First "Zudora" Episode

Scenario Writer Weaves Golden Threads of Mysterious East in Woof of Striking Imaginative Thanouser Photo Play

"THE Mystic Message of the Spotted Collar," the title of the first episode of "Zudora," gives an intimation of the mysticism of the forthcoming Thanouser serial.

Dr. Daniel Carson Goodman, the creator of the photoplay, has woven into the plot every possible thread of imagery, and his characters bear the imprint of the master craftsman who shaped them. The vision in the secret chamber, where Hassam Ali, portrayed by James Cruze, sees in the scented smoke from an incense filled brazier those events in his past life which bear directly upon his present wicked activities, offers a splendid insight into this weird Oriental character, and shows plainly Hassam Ali's all-devouring greed for Zudora's inheritance.

Then when Zudora, played by Marguerite Snow, the Countess Olga of "The Million Dollar Mystery," enters, and with a charming Cinderella innocence lays her hand upon Hassam Ali's shoulder, the contrasting emotions—the girl—the designing fakir-uncle—presents a situation of dramatic intensity seldom shown upon the screen. The girl smiles up into Hassam Ali's face and he returns the smile, but when her glance is elsewhere, the anxiety, the infernal lust for Zudora's wealth effaces his smile, and the real Hassam Ali beams in feverish glare upon the girl marked for his victim.

There is a letter which figures in "Zudora," the appearance of which upon the screen must be that of an aged document. Director Frederick Sullivan searched New York City for paper of the required size, quality and age. He was unsuccessful. Finally he obtained the back portion of a will filed in the Delaware county courthouse in 1876, a man whose property reverted to the county because of a felony committed.

This paper was just what Director Sullivan desired.

It is upon this almost historic paper that the following is written:

Madam:

Your dead husband in his will made provision for your child, Zudora, as follows:

1. The Zudora mine, valued at \$20,000,000, becomes hers unconditionally when she reaches her eighteenth birthday.

2. At her death, the property goes to her husband, or in case she is unmarried, to her nearest heir at law.

A special ink was necessary in the writing of this letter, as the fabric of the paper was so impoverished that every care was taken that the picture value of the old parchment might not be impaired. The experiment proved a success.

In and Out of Los Angeles Studios

Special to MOTION PICTURE NEWS

Los Angeles, Oct. 19. **U**NSETTLED weather conditions severely handicapped the cameramen of the Inceville studio—that of the New York Motion Picture Company, located on the beach near Santa Monica, recently. There were heavy fogs most every morning, and cloudy conditions each day caused loss of time, which required that additional efforts be put forth in order that schedule not be disrupted.

Principal among the more elaborate of Mr. Ince's output was "The Hateful God," a strong story of a bigot and his two children. A large number of the settings depict a circus and for those it was necessary to erect a mammoth tent.

Under the folds of this was staged a genuine circus scene. Action in three rings was filmed at one time, and retired circus clowns, now photoplayers, enlivened the scenes. Another tent housed a menagerie and many close up views of the animals were made. J. Frank Burke plays the part of a calloused father, supported by Enid Markey. The direction is in charge of Scott Sidney.

"The Mills of the Gods," in which Jay Hunt plays the principal character as well as directing the production, is from a Dutch story, and the scenes for the picture required the construction of a complete Dutch colony.

Canals were built on the plateau above the studio, and a row of Holland houses built for a back ground. J. Barney Sherry and Margaret Thompson were assigned prominent parts in this picture.

Stanton in Thrilling Scene

Richard Stanton, director and actor, has been given ample opportunity to prove himself a dare devil, in playing the name part of "The Desperado," from a story by Thomas H. Ince. In this he stands behind a window while the glass is broken out by bullets by a sheriff's posse attempting to capture him. Leona Hutton is playing opposite Mr. Stanton in this picture.

Walter Edwards has been filming a crook story at the New York Motion Picture Company studio, released under the title of "Destiny's Night." It shows the exciting experiences of a gentleman burglar and a society burglaress, which has for its climax a pretty romance.

A heart interest two-reel drama, "His Responsibility," from a scenario by Russell E. Smith, dealing with the story of a crook who embezzles from his em-

ployer and later returns the amount of money at a time when most needed by the rightful owner, was recently filmed under the direction of Fred. A. Kelsey, the hoodooed director of the Majestic-Reliance studios.

Irene Hunt was featured and other members of the cast are Ralph Lewis, Spottiswoode Aitken, Vester Pegg and W. E. Lawrence. In this ill luck again follows Kelsey.

A dummy was to be used in a scene made at Santa Monica canyon, and while enroute to the suburb the dummy fell off Kelsey's automobile, and caused a congestion of traffic.

A False Alarm

Street cars, autos and pedestrians saw it lying in the street in a life like posture, and one frightened woman, it is declared, called the police and informed the officers that a man had been killed. But Kelsey discovered his loss and returned and secured it just as an ambulance was arriving to convey it to the morgue, it is said.

In number ten of the Bill series made by Eddie Dillon, et al, for the Komic brand release, Tam Young, as Bill, who was not invited to the roof garden party given by Fay Tincher, the stenographer, breaks up the festivities by burning rags, turning in a fire alarm, and then soaking the guests by the use of the garden hose.

According to the script water was not to hit any of the players but Young did not understand it that way, and gave all a good wetting when they least expected it.

Animals in Universal Cast

In making a 600-foot picture, Harry Edwards, of the Universal L. K. O. Company, used 5,600 feet of negative film. The cast for this picture consisted of two cats, a kitten, and a large rat, the latter taking the heavy part and attempting to steal "my child." Thomas proved himself a hero.

Murdock MacQuarrie has been featured in a character part of a down and out musician who becomes a waiter, in the filming of "When its One of Your Own," under the direction of Charles Giblyn. The story was written by Calder Johnstone and is based on an incident he witnessed in a local cafe recently.

The daughter of the musician becomes a cabaret singer at the restaurant and when the manager attempts to force his attention on the girl the father makes known his identity. Mr. Giblyn has just finished filming "Jealousy's Reward," written by himself.

It is a story of a western town where an unsophisticated maid breaks with her lover when a city man arrives. The picture shows the results of hasty ac-



THE FETE SCENE IN "THE ROSE OF THE RANCHO"
(Lasky-Belasco—Paramount Feature)

quaintance. Murdock MacQuarrie and Agnes Vernon play leading parts.

Al. E. Christie has made an auto comedy in which a big feature was the race between a modern taxi in trouble and a primeval Olds with a bad heart. Lee Moran is the villain, Eddie Lyons the hero, and Virginia Ford the girl. Incidentally a Dutch grocery is introduced.

"A Dream of a Painting" is the title of the comedy vehicle of the Joker players under the direction of Allen Curtis. William Franey as the husband is dragged to an art exhibit by his wife, Gail Henry, where he sees and is fascinated by the painting of a princess. How he escapes from his wife, returns to the picture, and sees images in his dreams bring about many unusual comedy situations.



ROBERT LEONARD

Operation in "Yellow Streak"

Director Lloyd Ingraham, of the U studio, has been making a melodrama entitled "The Yellow Streak," in which lovers are parted by one coincident and reunited years later by another extraordinary event.

It will depict eastern and western life, and show numerous scenes in and about a local hospital, one being a very difficult surgical operation. The scenario for this is by Phil Walsh.

Francis Forde is busy with the filming of "Whom the Gods Love," for the Universal Rex brand, featuring Grace Cunard. This is another detective story and will contain a number of very exciting scenes in the kidnapping of the female detective and the rescue by her lover.

Production work was begun last week at the Universal studio on the filming of the company's third serial picture, "The Master Key," which will consist of fifteen two-reel weekly pictures.

The story is by John Flemming Wilson, well-known contributor to popular magazines, and author of several very

popular novels, and the scenario was prepared by Calder Johnstone and Robert Leonard. The production is in charge of Mr. Leonard, who also plays lead. He has selected Ella Hall as the leading woman for the series. Others selected for important parts were Wilbur Higby, heavy and Harry Carter second lead. A strong cast supports them.

The first release consists of a prologue



ELLA HALL

in which is shown an attempt of one miner to do away with his partner after they have discovered a very rich vein. Thinking the partner dead he leaves, taking with him the drawings which show the exact location of the mine—"The Master Key"—which he is determined to save in order to give his daughter an education and a place in society. The series have to do with his attempts to retain the mine.

One Reel Christmas Story

Otis Turner is again at work at the Universal studio in charge of the production after an absence of more than three weeks, during which time his company composed of Herbert Rawlinson, Frank Lloyd, William Worthington, Anna Little and Helen Wright was directed by Mr. Lloyd. Mr. Turner recently filmed a one reel Christmas story written by Ruth Anna Baldwin in collaboration with Manager Isadore Bernstein. Later Mr. Turner took up the filming of a multiple reel feature, "The Suburban," from the story by C. F. Dazy and scenario by James Dayton. This contains some very unusual scenes, including special horse races put on at the new Universal ranch.

The Rex Universal Company, directed by Joseph DeGrasse was home from a two weeks stay at the Angeles National Forest Reserve, near Saugus, Cal., where two pictures were filmed, "The Lion,

the Lamb, and the Man," a story of Kentucky hills people; and "An Idol of the Hills." The latter is a light breezy comedy and the first Pauline Bush has appeared in. The picture, when shown at the studio projection room elicited much very favorable comment.

Al. E. Christie, Universal Nestor comedy director, is on his way to New York City, to spend a short vacation with friends there. Mr. Christie has been at the West Coast making pictures for the past three years without a vacation, and during that time has witnessed the growth of what is now the Universal studio from one shanty with two sets to one of the largest motion picture studios in the world.

Chance Plays Trick with Actor

Director Henry McRea, of the 101 Bison Universal Company, in the filming of "The Trail Breakers," a western picture, made at the New Universal Ranch, made a daring leap from a locomotive running twenty-five miles an hour down an embankment fully thirty feet in height, without injury, and ten minutes later while running across some broken ground to stop some horses that were stampeding, slipped and twisted his



LEWIS DURHAM

knee badly tearing the ligaments of his leg.

Lewis "Bull" Durham, former mound man for the New York Giants, now with the New York Motion Picture Company at Inceville, claims the distinction of being "put away" more times and more ways than any other photoplayer. He has been kicked, punched, hanged, drown, shot and smothered to death. In

a recent production he was "killed" just as he was in the act of committing "murder."

To obtain the proper coloring for an elaborate story of the north woods, a large company from Inceville studio of the New York Motion Picture Company is spending a month at Bear Valley. The company will be directed by Walter Edwards and among the leads are Frank Borzage, who played a principal part in the Ince production of "The Typhoon." Louise Glaum and Jerome Storm.

Photograph Ball Scene from Derrick

Members of the Bosworth, Inc., companies had a holiday last week, both the Hobart Bosworth and Phillips Smalley pictures, "Little Sunset" and "False Colours," respectively, being finished. Both companies then began on new pictures. One of the most tedious tasks attempted at the Bosworth studio was that of making almost three hundred Reach baseballs—and in world series week at that—roll into place and spell the title "Little Sunset," for the baseball picture



VIOLET MERSEREAU

from the stories of Charles Van Loan, produced by Mr. Bosworth.

For this title the company built a derrick of the design used at oil wells, thirty feet high, and from the top of this the camera was operated.

The chamber of commerce and citizens of Hollywood—the home of the Universal in California—wanted to celebrate the turning on of the new cluster street lighting system recently installed, and they asked Manager Isadore Bernstein to help them out.

He did and the Universal players put on a regular circus parade, side show, the big three-ringer, wild animal show, Wild West, and turned loose the red lemonade, peanuts and pop corn. It was the biggest night in the history of Hollywood.

Henry McRea and Rex de Rosella

presided at the Wild West and assisted by the U wild animals and cowboys put on a regular Buffalo Bill attraction.

Robert Leonard a Hypnotist

Francis Ford and Grace Cunard staged the Hindu cabinet mystery and others. Robert Leonard made his first appearance as a hypnotist. Al Curtis as the magician for the Queen, Marie Walcamp, produced everything she wanted from snakes to a real—or reel-hero, William Clifford.

Acrobats and trapeze performers were present with good acts. A big favorite was the melodrama burlesque staged by Lee Moran, Joe King, Stella Adams and Eddie Lyons, to the accompaniment of a fiddler. "Kurtis' Kurious Kreatures" was the title of the side show and the receipts amounted to more than \$300 which go to the funds of the Children's Hospital of Hollywood.

Manager Bernstein was grand marshal of the event, and like the chief mogul of the county fair appeared always on his pretty white pony. Local newspapers estimated the attendance at between forty and fifty thousand people.

Scenario from the play "The Truth Wagon," written especially for Max Figman by Hayden Talbot, is being prepared at the studio of the Masterpiece Film Company by M. De La Parelle and E. J. Clawson, and the work of producing this will be commenced upon the return of Mr. Figman, who is now in New York City, in company of Frank C. Hill, secretary of the company.

To use the words of the playwright, this is "A comedy based on the sober truth," in which an heir, who had spent his days joking and jesting, buys a newspaper and resolves that it shall print only the truth.

This results in his loss of friends and money; the defeat of his father for governor; in him becoming the target for the wrath of politicians and capitalists; and creates many stirring scenes that may well be portrayed in pictures. Lolita Robertson will play the part of Helen Dunn, the "sob" sister.

"Last Egyptian," New Oz Film

The Rolin Film Company has begun producing, after being closed for two weeks. The company is now nine reels ahead of its release with Sawyer.

The Oz company players recently began "The Last Egyptian," from a novel by L. Frank Baum, which will consist of five reels. As with all previous productions, the company had all new sets made for this picture. Two of these were remarkable for their size and beauty. One was of an English ballroom and the other the exact reproduction of the Lord Cromer Palace, in Cairo, made from photographs. By comparison of pictures of Egyptian palms with the California palms it was found there is very little similarity, and the scenic department made a grove of eighty trees, each sixty feet high, which were "planted" in the sand on the bank

of Balboa Bay, southwest of Los Angeles.

Billy Elmer, one of the leading members of the Jesse L. Lasky Feature Play Company, taking the parts of Cash Hawkins in "The Squaw Man," Trampas in "The Virginian," Biff Bates in "The Making of Bobby Burnitt," all of which have been released, has had a very remarkable career.



BILLY ELMER

First he studied law, but gave up Blackstone for the lyceum platform. In New York he became a Shakesperian actor, which line he followed for several years. For three years he was in stock in New York, Chicago and San Francisco, and it was at the latter place that he first entered the fighting ring at the suggestion of a physical culture trainer of an athletic club.

He climbed to the championship of the welterweight class and then with Bob Hollard appeared in "Sporting Life," the big English melodrama, for three seasons. Then he became a physical culture instructor of the Millionaire's Club in New York; wrote two books on boxing, published by Spalding; went back to the stage to play in stock; with his father, a San Francisco banker, entered the oil business at a time when conditions were good, but suffered severe losses when the bottom dropped out of the market. A friend persuaded him to "come down and see us make pictures," which resulted in Elmer becoming a photoplayer. He has since been with the Biograph, Selig and other companies, and with the Lasky players since the opening of the studio the early part of this year.

Mr. Elmer will be seen playing the heavy part of the Spaniard in "The Ghost Breakers," featuring H. B. Warner, and Isaac Perry, the colored attorney, in "The Rose of the Ring," featuring Theodore Roberts.

GLADYS WYNNE A STAR IN FIRST SCREEN APPEARANCE

The part of leading woman does not often fall to the lot of an actress on the occasion of her first appearance before the camera, but such has been the experience of Gladys Wynne, who has the role of Kate Heathcote in the



GLADYS WYNNE

Kinetophote's film production of the late Sutton Vane's "The Span of Life."

She was brought to this country from the English stage to take the part of Mary in "The Servant in the House" at the instance of her cousin, Edith Wynne Matthison.

That was in 1908 after she had played in London with such men as F. R. Benson and H. P. Irving. Later she returned to London and played in "The Servant in the House" with Henry Miller. Returning to New York she was engaged for the metropolitan run of "Romance," after which she became a part of the brief life of "What Would You Do?"

George Arliss soon after that began rehearsing "Disraeli" and found in Miss Wynne the woman he wanted for his lead. Last summer when the Kinetophote began casting for "The Span of Life" Miss Wynne was selected as the proper type for the heroine of the play.

JANE URBAN AND MAI WELLS SIGN WITH OZ

The Oz Film Manufacturing Company has recently engaged Jane Urban to play leads in its dramatic productions.

The company also announces the engagement of Mai Wells for character parts.

William J. Flynn in New Serial

Well Known Detective to Appear in a Series, Each Episode Complete in Itself—Film Attractions Will Release Picture

A NEW kind of serial, combining the name of an individual known by title to millions of persons, releasing through state rights buyers only, and basing its appeal on the completeness of each release rather than on suspended interest, is being prepared.

William J. Flynn, chief of the United States secret service, is one of the men behind the idea. His present position, as the head of Government detectives, and a continuous period of service of almost twenty-five years, have been productive of many experiences which will be produced in motion pictures.

C. V. Henkel, president of the Film Attractions Company, is in charge of the production. Mr. Henkel's most recent feature release was the six-reel costume spectacle, "The Three Musketeers."

The serial will consist of approximately twenty releases, or episodes. The aggregate material for the score of scenarios has been taken from the twenty most famous cases of which Mr. Flynn has had charge as chief of the secret service.

Each episode will be complete in itself, but the same principals will be featured in each of the twenty releases. The theme of the serial, covering a wide range of activities by government agents, will be Chief Flynn's personally evolved slogan to those whom he and his operatives have convicted, that "crime does not pay."

Instead of releasing through program exchanges, the serial will be marketed to state rights buyers. Some territory, it is said, for which Mr. Henkel has conducted negotiations in person, already has been closed.

"There is no doubt about the general popularity of serials," he stated. "Their tremendous success everywhere is evidence of their value to exhibitors. But the feature exchanges, apart from those operated by program producing companies, have never had an opportunity to capitalize this popularity. This secret service serial has been designed with that purpose in view.

"Chief Flynn's name is known either directly or by title to almost every man, woman and child in America. He is a big man, with a big job, and the stories portrayed in each release is based upon one of his twenty biggest cases.

"The principal characters will be two of his most experienced and confidential agents—a man and a woman. To this day neither is aware that the other is a government operative. Each believes the other to be active in behalf of 'systems' or bands of criminals operating in defiance of the government, either as counterfeiters, embezzlers, smugglers, and in some instances as promoters of monopolies in violation of the Sherman anti-trust law."

Mr. Flynn has often been called upon to pass final judgment upon certain kinds of film wherein was contained scenes affecting government operations, and is conversant with practically every phase of the industry.

His personal acquaintance with newspapermen throughout the country has proven valuable in making arrangements for publicity to accompany the releases. Recently a series of articles by him about his various experiences was published in the New York *Herald*, and one other Eastern paper. Many of his personal experiences have been syndicated in narrative form to newspapers throughout the entire United States.

Each episode of the serial will be written in fiction form for publication in newspapers in all of the cities where the series is booked to exhibitors, thus enhancing the popularity of this unusual series of photoplays.

EDISON ACTRESS A SCREEN FAVORITE

One of the most popular and fascinating girls on the screen today is Sally Crute, the leading lady of the Edison Company.



SALLY CRUTE

After successful engagements on the legitimate stage in such productions as the "Rosary," "Three Twins," and "The Deep Purple," Miss Crute responded to the call of the silent drama and made her debut with Essanay in Chicago. A season with Solax followed, and in August, 1913, she joined the Edison ranks at Bedford Park.

Motion Picture News

HAS THE QUALITY CIRCULATION OF THE TRADE

MOVING PICTURE NEWS EXHIBITORS' TIMES

Published Every Week by

EXHIBITORS' TIMES, Inc.

220 West 42nd Street, New York City.

TELEPHONE BRYANT 7650

Chicago Office, 604 Schiller Building

WILLIAM A. JOHNSTON.....President
 HENRY F. SEWALL.....Vice-President
 E. KENDALL GILLET.....Secretary
 H. ASHTON WYCKOFF.....Treasurer
 WENTWORTH TUCKER.....Ass't Treasurer

WILLIAM A. JOHNSTON.....Editor
 LESLEY MASON.....Managing Editor
 WILLIAM RESSMAN ANDREWS.....News Editor
 H. ASHTON WYCKOFF.....Business Manager
 R. M. VANDIVERT.....Advertising Manager
 E. J. HUDSON.....Circulation Manager
 C. J. VERHALEN.....Chicago Manager

This publication is owned and published by Exhibitors' Times, incorporated under the laws of the State of New York. The offices and principal place of business are at 220 West 42nd Street, New York City. The address of the officers is the office of the publication.

Entered as Second-Class matter at the New York Post-Office.

Subscription \$2.00 per year, postpaid in the United States, Mexico, Hawaii, Porto Rico and the Philippine Islands. Canada, \$3.00; Foreign, \$4.00 per year.

ADVERTISING RATES ON APPLICATION.

Copy for next issue must reach us by Tuesday, 5 p. m.
 For Releases see Pages 58, 60, 62, 64, 66
 For Buyers' Guide see Page 55.

Cuts and copy are received subject to the approval of the publishers and advertisements are inserted absolutely without condition expressed or implied as to what appears in the text portion of the paper.

Vol. X October 31, 1914 No. 17

A Proof of Healthy Prosperity

IN this issue MOTION PICTURE NEWS offers its second quarterly report of national trade conditions for the consideration of the industry.

The report published in the Dayton Convention Number, dated July 11, was the first undertaking of its kind attempted in this field. It created a profound impression and satisfied an actual need.

The present one, for several reasons, will be found even more useful than its predecessor.

* * *

TO enable the reader to comprehend, almost at first sight, the significance of the mass of data presented to him in the report, the substantial facts contained in the entire collection of articles have been tabulated in a chart, under column headings which will permit the reader to ascertain immediately anything he wishes to know about the business in any particular section.

Supplementing the chart are articles which enlarge upon the data in its columns and present such additional facts about conditions in the various localities as did not lend themselves readily to tabulation.

Taken together, the two form a compact and readily understood digest of the business, the value of which no producer, feature buyer or exchange man can ignore.

* * *

THE most important feature of the report is the revelation of a general prosperity throughout the industry which has demonstrated itself to be war-proof and depression-proof.

In a few cities near the large industrial centers of the East, conditions brought about by the European conflict have reacted directly upon the exhibitor.

But these make the condition of healthy prosperity elsewhere all the more convincing.

Most of the motion picture trade centers of the country have had dull periods of long or short duration. But scarcely an exhibitor can be found who traces this to the war.

* * *

THE market for good pictures is just as big and just as capable of absorbing all high quality film that is offered as it ever was.

For the mediocre picture, the feature in name only, the slovenly, slipshod, badly produced, badly acted and badly photographed photoplay, whether a split reel or an eight-reel multiple, there never was a large market, and there is less and less opportunity to "put them across" every month.

* * *

THE fact that it is becoming less and less profitable to produce poor pictures, and more and more profitable to produce good ones is a symptom of normal, healthy prosperity.

And all the calamity howls of those who are experiencing the shock of having worthless pictures thrown back at them will not make it otherwise.

A Magazine With a Purpose,—But What Purpose?

THE announcement that M. A. Neff and two members of the Ohio Board of Censors are about to issue a magazine "in the interests (?) of the exhibitors of Ohio" is calculated to excite both laughter and curiosity.

Perhaps also a little suspicion.

It is only natural, after the unsolicited censor law which Neff foisted upon the exhibitors he was supposed to protect, that anything he does "in the interests" of the exhibitor should be looked at askance.

* * *

BUT why are two members of the censor board cast for parts in Neff's latest benevolent farce?

It is acknowledged, without argument, that the Ohio censors need a good many things. But do they need a house organ?

Or is it rather to be supposed that the new publication needs them?

The Ohio exhibitor, having had forced upon him a censor law which he didn't want, is now to be called upon to support a paper emanating from the same source and of which he doesn't see the necessity.

Unless, of course, the Neff publication goes out of existence when the Neff censor law is repealed. That is the one ray of hope.

Graham Sees Fewer Five-Cent Theatres

Manager of Universal, on Eight-Week Tour of United States and Canada, Finds General Demand for Quality Pictures

Special to MOTION PICTURE NEWS

Los Angeles, Oct. 19.

ACCORDING to J. G. Graham, general manager of The Universal Film Manufacturing Company, while at Los Angeles, on a tour of eight weeks about this country and Canada, investigating the general conditions of the motion picture industry, business of exchanges and exhibitors is up to the average for this season. So-called multiple reel features are among the discards; the days of the five-cent theatres are numbered; and good feature productions from books and plays, regular programs with good short stories and comedies, and the serial pictures will continue in demand.

This opinion of Mr. Graham was based upon conditions found on a trip through Missouri, Kansas, Nebraska, Colorado, Texas, Oklahoma, New Mexico, Arizona and California.

WILD WELL KNOWN IN FILM CIRCLES

Jack Wild, the publicity manager of Hepworth-American, has become known throughout film circles as one of the live wire men in the business.



JACK WILD

He has a thorough knowledge of the industry and is conversant to a high degree with the advertising methods best suited for successful exploitation of his company's productions.

ROLFE GETS FILM RIGHTS

The B. A. Rolfe Photo-Play Company, which releases through the Alco program, has signed a contract with the Bobbs-Merrill Company in which they acquired the motion picture rights for the novel, "Satan Sanderson," by Hallie Erminie Rives. The sale was effected through Frank Henry Rice, literary agent, 145 West Forty-fifth street.

"Four weeks ago I left New York and I have been going ever since," Mr. Graham said. "From here I will go north through Oregon and Washington, and then through Canada, where our company has a large number of exchanges.

"So far I have found the Universal company products in good demand. For the number of releases we have each week we stand in the front rank. We have a very good percentage of the rentals.

"The most notable change that has come to my observation is the passing of the five-cent theatre as a place of amusement. It will remain, but will decrease in number. The general trend is toward better quality and the demand means that the exhibitor must first increase the price of admission, so that he can afford to pay the exchange a higher rental.

"In turn, the exchange can pay better prices for pictures, and the manufacturer will thereby be in a position to spend more money on its productions, and consequently make better productions.

"The padded picture of several reels misnamed a feature is a dead issue. While it was here it did more harm than good. The big production on the order of 'Neptune's Daughter,' 'The Spoilers,' 'The Escape,' and others, will always have a place.

"The serial picture is very popular and is holding its own. There is no doubt but that it can be retained as a feature for motion pictures just as for a newspaper or magazine. The regular program is to be the program of the future, and every week it is coming back into its own."

The European war, according to the belief of Mr. Graham, has not affected the business of motion picture exhibitors or exchange men to any extent. "It has served to cut down the number of foreign-made pictures coming into America," he said, "and likewise reduced the sale of American-made prints in Europe."

"The general condition over the country is up to the average for this season. In the Southwest there is a stringency because of the lack of sale of cotton. Colorado exhibitors are suffering because of the mine difficulty. On the coast exhibitors report poor business, but all of these conditions are purely local, and will change quickly."

While here Mr. Graham was the guest of David Bershon, manager of the California Film Exchange, Inc., and Isadore Bernstein, manager of the Universal studios. He departed from here the first of the week going to Washington and Oregon, and from there will go through Canada. Mr. Graham does not expect to reach New York until the middle of November.

MARGUERITE CLARK IN LASKY'S "MERELY MARY ANN"

By arrangement entered into between Samuel Goldfish, general manager of the Jesse L. Lasky Feature Play Company, and Adolph Zukor of the Famous Players Film Company, dainty Marguerite Clark, best remembered from her recent triumphs at the Little Theatre, will appear in the Lasky production of the Liebler Company's famous dramatic success, "Merely Mary Ann."

Miss Clark's first professional appearance was under Milton Aborn, at Baltimore, in 1899. Following a season



MARGUERITE CLARK

or two as leading woman with De Wolf Hopper, Miss Clark appeared successfully in "Babes In Toyland," "The Pied Piper," "The Beauty Spot," "The Golden Garter," "The King of Cadonia," "Jim, the Penman," "Baby Mine," "Snow White," "When the World Was Young," "Are You a Crook," and following these triumphs, was heartily commended by the entire press of New York for her work in the Little Theatre production of "The Affairs of Anatol."

Wm. C. De Mille will write the screen version of "Merely Mary Ann." Cecil De Mille will direct and stage the picture, Wilfred Buckland will act as artistic director and the entire facilities of the Lasky studio will be devoted to making Miss Clark's first Lasky appearance an important event.

FOREIGN FILM CONCERN INCORPORATES FOR \$100,000

The Foreign Film Corporation, of Philadelphia, has been organized with a capital stock of \$100,000 for the sale of state rights and exclusive territory. The corporation represents the leading manufacturers of Italy and France.

Their first release, on October 10, was a beautiful feature entitled, "Back to the Waves."

"SHORE ACRES"

(All Star-Alco—Five Reels)

REVIEWED BY CLIFFORD H. PANGBURN

JAMES A. HERNE, famous for his plays depicting the life of the simple fisher folk of the Maine coast, wrote his most popular work in "Shore Acres." Its popularity alone would justify its production for the motion picture screen, but the excellence with which this transfer has been accomplished makes it thoroughly worth while.

The mere fact that the action takes place beside the ocean makes the advantage of a film production obvious. However skilled a scenic artist may handle a production on the stage his efforts look puerile when compared to the background of real ocean waves, provided by the camera. The scenes on the storm-tossed schooner, which are most realistic in the



THE MOTHER INTERCEDES FOR HER DAUGHTER

film, would be entirely impossible in the original form of the play.

The interiors are few in number, and none of them require anything elaborate in the nature of decorations, but they really look like the humble homes which they represent, which is far more important. As for the exteriors, there is a wide variety in them, and they are all well chosen, some being unusually fine examples of photographic art.

Charles A. Stephenson, who is featured in the role of Nathaniel Berry, plays the lovable old soldier in a convincing and sympathetic way, which wins the audience from the start. William Riley Hatch is his hard-hearted brother. Violet Horner makes a charming heroine, and in common with the other principals, handles an emotional part without over acting. Conway Tearle is seen as her lover, while others are E. J. Connelly, Harry Knowles and Gladys Fairbanks.

The story very much condensed concerns a farmer who is influenced to put his farm into a building scheme. The man who so influences him wants to marry his daughter and when she elopes a younger daughter makes insinuations which lead her father to seek the young couple's lives.

The father's brother is a fine old man, a veteran of the Civil war and the keeper of the lighthouse. He acts as a peacemaker and eventually the family is reunited by the last of his long series of tremendous sacrifices.

Altogether, "Shore Acres" is a picture which any exhibitor should be proud to run and which ought to give him solid reasons for his pride. The fame of the play gives it advertising value, and it comes up to expectations.

"THE TREY O' HEARTS"

(Gold Seal—Twelfth Chapter.)

REVIEWED BY PETER MILNE

WE have here the twelfth episode of "The Trey o' Hearts." Only three more to follow. And what will be the outcome? It has come now to be a difficult question to answer as to which of the Trine sisters Law will marry.

In the beginning of the story it was Judith's avowed purpose to murder Law in cold blood. But she didn't figure on falling in love with the gentleman. And now Judith, as well as Rose, is continually plunging herself into great difficulties, from which Alan is called upon to rescue her.

So it seems a perfectly legitimate question to ask as to which of the young ladies he will eventually take as his wife. Perhaps he will prefer to remain a bachelor, and spend the rest of his life resting up after his strenuous duties, but it is hardly likely that the story will terminate in this manner, and it will be a decided departure if we are not given to understand that Law and one of the twin sisters are made one.

Then again, Seneca Trine swore that if Alan ever married Rose, Alan would not live to spread the good news. It is a debatable question as to whether Trine's prophecy will be correct or no. Certain it is that if any villain ever deserved triumph, friend Trine does. He is the most abhorrent director of villainy we have ever seen, anywhere, on the screen, stage or off. He seems as he sits huddled in his cripple's chair, or as has lately been the case, in his private car, the very embodiment of all that is bad and unworthy. When his carefully laid plans go amiss he fairly boils with rage. He is so utterly helpless in his fury that he sometimes strikes one as being rather humorous.

It's only three weeks more now until we shall see the last of hero, heroines and villains, and these questions will doubtlessly be answered in the last three chapters. And, although difficult as it may seem, we must wait. Here in this episode entitled "Mirage," the action takes place for the most part on a desert. That it is a real desert is ascertained by the sandstorms that continually appear.

A fine exposure of a trail marks the end of the second reel, with Alan and Judith holding sway over the latter's father, and Rose for the time under the protection of Barcus.

"A GENTLEMAN FROM MISSISSIPPI"

(World Film—Five Reels)

REVIEWED BY PETER MILNE

THE merry old Southern colonel, kind to his employees, humorously severe with his family, philanthropic towards the poor, and hard on his enemies, if such he has, has often been made the central figure of books and plays; and here we have one of the latter turned into a picture, with Thomas Wise leading the cast, and making the picture.

He is exceptionally well cast, as he has a perfect understanding of the part, having played the same role on the stage several years ago. The humorous touches that he puts in throughout the picture are genuine humor, and it may be said that in less accomplished hands these touches would appear entirely forced and lose their excellent effect.

The story is simple, easy to follow and never unfathomable or at all involved. It is conventional, true, but it is Mr. Wise's acting that will carry it through, and give it the appearance of an unhackneyed picture.

Although containing enough comical phases to produce many a hearty laugh, the picture is not all comedy, as it contains a number of dramatic situations, which materially heighten the interest.

Imagine the situations that arise when a gentleman from Mississippi, who has newly been elected Senator, arrives in Washington and suffers all the pangs of fear that beset one when setting foot in a taxicab for the first time, again making his maiden speech in the Senate, meeting newspaper men and at last defeating a group of corrupt Senators, who only hold their positions, by virtue of crooked methods, and who have tried hard to bring about the downfall of the honest man.

The picture is full of just such situations combined with a very plain love story, which is prominent only in parts. It is truly refreshing to see a picture that does not rely on its love element for success, and one that does rely on its character portrayal, which is carried off in a convincing manner, by an artist, who knows his business.

"SIR GALAHAD OF THE TWILIGHT"

(American—Two Reels)

REVIEWED BY T. S. MEAD

THIS is a most admirable picture of an interesting and plausible drama, the scenes of which are laid in the forests of the great Northwest. The play hinges upon the unselfish love of Jacques Lennaux, a big-hearted, honest trapper, for Clotilde, a tangle-haired, dreamy-eyed daughter of the North.

Through the perfectly logical development of the plot are dispersed enough exciting incidents to hold the attention from start to finish. The many beautiful forest scenes reproduced by excellent photography would alone be sufficient to place this picture far above the ordinary.



CLOTILDE SEES THE LIGHT

Clotilde weaves a chain of romance around the picture of Watt's Sir Galahad, which she has run across, near a deserted lumber camp. She knows not what it means, but it expresses her ideal man. Jacques she loves with the devotion of a little, trusting sister, while Jacques loves her with all the passion of the forest. At her father's deathbed—such is her father's dying wish—they are married.

She is happy, until one day her Sir Galahad appears in the guise of a strange young trapper. Dick, the stranger, chivalrously befriends her in an hour of need. Later, he saves the life of Jacques, who is returning from a visit.

A note from Clotilde to Dick falls into the hands of Jacques, and shows him the true situation. His jealousy is conquered by his big, better nature, and in order that he may no longer stand between Clotilde and happiness, he sacrifices his own life, thereby proving himself the real Sir Galahad of the Twilight. The personality of Vivian Rich is particularly suited to the role of Clotilde, and she plays it with much charm and freshness. The other parts are most convincingly rendered by a cast including Harry Von Meter, William Garwood, Jack Richardson, Perry Banks, and Reaves Eason.

DAYTON EXHIBITORS WILL FIGHT FOR LOWER ELECTRICITY RATE

Special to MOTION PICTURE NEWS

Dayton, O., Oct. 21.

NEGOTIATIONS between a special committee from the Dayton exhibitors' league and officials of the local power and light company, relative to the securing of a better rate for light and power for motion picture houses, has proven fruitless. In reply to the exhibitors' protest that there should be a uniform, reasonable rate to the motion picture shows, the lighting company has declared that the state laws prevent them from discriminating in favor of the exhibitors and now declines to take any action in the matter.

The complaint of the exhibitors has been that the rate varies from 2 to 9 cents per kilowatt hour. Members of the league say they are preparing slides which will be thrown on the screen in support of the proposed local bond issue for a municipal lighting plant, which proposition is to be voted on at the general election, November 3.

"THE TREY O' HEARTS"

(Gold Seal—Thirteenth Chapter)

REVIEWED BY PETER MILNE

IF the principals of the cast were expecting something unlucky to befall them, as this is the thirteenth episode of the thrilling serial, they had ample ground for their fears, if they knew just the variety of stunts the script contained for them to perform. "The Jaws of Death" just as a descriptive title as could be employed, defines, only partially, the substance of the two reels.

To say that the events staged are hair raising seems almost too weak; to say that they are death defying seems nearer their correct nature. But it is not the events alone that are wholly responsible for the numerous thrills that put in their appearance in this number.

It is the remarkably clever manner in which they are staged, that keeps one in continual suspense, so that when the event which has been so cleverly led up to occurs, the spectator will have to be thirsty for sensation indeed, if he has not had enough.

When the chapter has gained headway, and after the usual synopsis has appeared, followed by a few introductory scenes, Alan, Barcus and Rose are seen crossing a deep gorge, by means of a bridge, suspended from the two banks by ropes.

Marrophat and another of Trine's party follow them. When the first party has arrived at an old mine, Alan returns to destroy the bridge in order to cut off pursuit. He has partially severed one of the ropes when he is made the captive of Marrophat, and made prisoner in an old mine together with Rose and Barcus.

Marrophat's fiendish plan is to drown the three of them by turning on the water and flooding the mine, which plan he straightaway follows out. Then Judith enters, bent on saving



JUDITH AND TRINE IN LAW'S POWER

Alan from destruction. She steps on the bridge, is half way across, and then—no it doesn't happen—then, a flash back shows the rope slowing coming apart under the strain, another flash shows Alan, Rose and Barcus up to their necks in water, another flash, shows the fuse of a bomb placed in the mine rapidly burning, then another scene of the rope, and then a glimpse of Judith, just as the bridge has broken, and she has grasped the remaining rope as a last resort.

We leave her swinging in midair and return to the other three who are all but exhausted, then the bomb explodes, tearing a hole in their prison and they are saved.

Judith manages to reach the side of the gorge in safety, and after a few supplementary scenes the installment is over—but, and the word is accented, if you think that the other chapters were thrilling, just wait.

ALCO REPRESENTATIVE REPORTS GOOD SOUTHERN BUSINESS

NAT I. BROWN has just returned from a southern trip in the interests of the Alco Film corporation. He traveled through North and South Carolina, Tennessee, Louisiana, Mississippi, Georgia and Florida, and was gone three weeks.

"THE COUNTY CHAIRMAN"

(Famous Players-Paramount—Five Reels)

REVIEWED BY PETER MILNE

IT is rather strange when one stops to think of it, but the old plays that amused and entertained the audiences of former times still retain a strong hold on the patrons of the silent drama. Recently there has been a considerable number of past stage successes reproduced in motion pictures. If any of them don't take there is something radically wrong with the people, not with the pictures.

But there is no conceivable apparent reason why "The County Chairman" will not be a huge success. It certainly ought to be and judging from the warm receptions it has already received, it will be.

Considering the picture from every side, it is perfect enough for the most critical. Written by George Ade, produced by Henry W. Savage, and acted by a cast headed by Maclyn Arbuckle, the three most important angles of the play are well taken care of. And photography, lighting, scenes, and the rest of the acting, even to the host of supernumeraries employed are as near perfection as has ever been reached.

George Ade's works have been seen on the screen before, and have been universally acclaimed as very funny. This picture, a mixture of comedy and drama, is destined to even greater success, due to its many merits.

Maclyn Arbuckle, who carries the title role of Jim Hackler, played the same part in the stage production and has therefore a perfect understanding of it; his acting is not to be criticized, as he plays his role of the jovial, yet severe county chairman in excellent style. Willis P. Sweatnam as Sassafra Livingston, the old colored servant, gives a good account of himself. Harold Lockwood, whose face is well known in Famous Players pictures, plays the part of the lover and the partner of Hackler in his usual brisk style.

William Lloyd as Elias Rigby, the rival candidate, is the villain of the play and a good one. The rest of the cast, Daisy Robinson, Helen Aubrey, Mabel Wilbur, Amy Summers and Wellington A. Playter give a correspondingly good account of themselves.



THE CHAIRMAN SPARES RIGBY

In the course of the picture there are a number of counterplots introduced, which at first seem to deviate from the main story, but later on appear to be entirely necessary, which only goes to show how well the production is constructed.

A number of the laughs caused in the course of the picture are due to Mr. Arbuckle's handling of his varieties of cigars, good, bad and indifferent, the former brand of which he keeps for himself. There is a slight tendency to overwork this piece of humor.

As said at first, the picture cannot help but be a success. It will most certainly put one in a good humor, but again the picture is not all comedy, there are serious touches in parts, which are introduced at opportune moments throughout the five reels. Maclyn Arbuckle is the leading light and his work will stand out as one of the best pieces of character acting ever seen in pictures.

"THE MILLION DOLLAR MYSTERY"

(Thanouser—Eighteenth Episode)

REVIEWED BY PETER MILNE

FROM the very outset of this startling story it has been obvious that no money was spared on the magnificence scenes that demanded it. The film possesses a distinctive individuality in regard to this end of the producing, and it is well that it does, as however well attired and imposing the players are, they will appear out of place if the sets have been neglected or left to take care of themselves.

But no such fault can be charged against the producers of "The Million Dollar Mystery," and here in this chapter the magnificence of the sets and the gorgeousness of the dress of the people that move about in them will be noticed by all. A ball is staged in the princess' house, who happens



THE PRINCESS RECEIVES THE LOVERS

to be a member of the Black Hundred, and the main ball room which is the background for not a few scenes looks the part to perfection.

To make the spectacle all the more imposing, the ball in progress is a costume affair, and all manner of elegantly arrayed personages are seen to be moving to and fro. Flo and Jim are also present at this ball, as the princess was forced by the countess to invite them. They are attired in the old Colonial style of dress. Braine and the countess come clothed in exactly the same kind of costumes, and their plan which works wonderfully well for a pace, is to kidnap Florence and lock her in a room of the house. This they do. Jim goes home to look for her after he has waited for some time. Not finding her he comes back to the ball, with Jones, the butler.

Florence in an upper room is threatened with death by being blown to atoms by a bomb if she doesn't disclose the whereabouts of the million. She is protesting her ignorance of the matter when a premature explosion of the bomb sets the house on fire.

This forms a thrilling spectacle, and Jim after entering the burning house to rescue his fiancée, is forced to descend via a rope after she has gone before. Safely away from the burning house the second reel of "Trapped by the Flames" comes to a close, and will be sure to leave the audience in the same state of wonderment that has followed each episode.

NEW OPERATORS' LAW IN SPOKANE

Special to MOTION PICTURE NEWS

Spokane, Wash., Oct. 19.

HENCEFORTH motor-driven machines will be permitted in the operating booths of picture theatres in Spokane, under the terms of a new ordinance agreed upon in conference by the city commissioners. Previous to this time, motors have been forbidden.

Certification of operators will be required under the ordinance, as finally agreed upon. Operators will be permitted to register without examination or the payment of a license fee, the certification issued by the commissioner of public safety to be good in any house in the city.

"IN THE GLARE OF THE LIGHTS"

(Essanay—Three Reels)

REVIEWED BY C. J. VERHALEN

THIS three reel production, adapted from the story of the same name running in the *Ladies World*, was released on October 17. This is the second of the prize stories containing the missing chapter.

Bushman again plays the lead in his inimitable style. His role, however, this time, is that of a young mill worker who is ambitious to become an actor. Some very splendid views of steel mills are shown with the roaring and red-hot furnaces illuminating the pitch darkness.

One especially exciting scene is the fight in close proximity to tanks containing molten metal. A very good cast has been provided, which includes Lillian Drew as the other lead. Miss Drew does some very good work in the interpretation of the role she assumes. Harry Dunkinson as Corrigan is to be commended. Other well known players are Helen Dunbar, Beverly Bayne and Lester Cuneo.

Glen Duval, a worker in the steel mills, desires to become an actor. Brandigan, who is working in the same mill, is jealous of Glen because of the fact that Joe's sweetheart, Martha, appears to like young Duval too much.

One morning on his way to work Glen finds the unconscious form of Wanda Dawson, the actress, by the railroad track.

That evening, when Glen returns from the mill, he tells Wanda of his ambitions for the stage. She encourages him, and later Wanda's manager appears and engages him as an actor. Glen falls in love with Wanda, is afraid to declare it because his position is so much below hers. One evening Bland is unable to appear. The manager seizes on Glen as a last resort. Glen's work is a great success.

Bland offers Wanda the chance to start in another produc-



BLAND MAKES HIS AVOWAL

tion, just then Glen enters to declare his love, and denounces both and returns to the mills.

In the steel mills Brandigan has become foreman. He gives Glen a job. Joe is still jealous. He harasses Glen to the limit. Finally they meet each other in a fist fight in the glow of the big furnaces. It so happens that Wanda is playing the town. She hears of Glen's occupation, and arrives just as the fight is at its critical stage. He recognizes Wanda and takes her in his arms.

SPOKANE REVOKES BAN ON WAR FILMS

Spokane, Oct. 19.

THE official ukase, barring the exhibition in local theatres of pictures dealing with the European war, has been revoked. Mayor W. J. Hindley, who is city theatre censor, has sent a letter to the theatre managers with the information that he has reconsidered his original order.

"THE MIDNIGHT RIDE OF PAUL REVERE"

(Edison—Two Reels)

REVIEWED BY CLIFFORD H. PANGBURN

MUCH of the interest in this picture is due to the fact that it is a reissue of a film made ten years ago. Much has been written about the startling advances of the film industry and art during the past ten years, and most of it is correct, yet this ten-year-old film seems quite the equal of many of the most modern.

One of the most difficult things which confronts the motion picture producer is the staging of a film depicting Colonial days in such a way as to give an effect of realism. For some reason it seems a particularly hard age to depict, and



REVERE WATCHES THE BRITISH

the very latest pictures of the sort show this just as much as older ones.

For this reason it is interesting to note the considerable success which the producer of this picture has met with in the matter of obtaining a convincing atmosphere. He did his work ten years ago, but he knew what he was doing and how to do it.

The film is the story of Paul Revere's ride, and the historical details as far as known were carefully followed.

"LOVE AND SURGERY"

(L. Ko.-Universal—Two Reels)

REVIEWED BY PETER MILNE

WE have seen all varieties and brands of slapstick comedy that the market of today offers, but "Love and Surgery" contains more slapstickism, so to speak, than all the rest.

The L. Ko. is a new brand added to the many now under the Universal banner, and if more follow and come up to the standard set by this, they will establish a name for themselves, a name to be smiled at whenever it be heard.

Slapstick comedies have for some time been great favorites with some people, but, like all great favorites, they have those who do not look upon them in such a favorable light. The farcical burlesque elements of this picture will be enjoyed to their fullest extent by most of the male audiences. And by those who do not mind the extreme rough work, perhaps a little suggestive in its roughest moments, a warm welcome will be awaiting the picture.

Henry Pathe Lehreman is the director and second leading man of this picture and Billy Richie is the star to whom the final honor of creating laughs must be allotted. But it is the ingenious mind of the director that conceived the plan and to him must go a great amount of praise.

As is usual with this variety of picture, there is no plot; if there is, it will be completely obliterated in the mass of uproarious events. Brick throwing, punching, running, darning falls, diving through walls and roofs, flirting, shooting and countless other varieties of furnishing hilarity are linked together in this picture with such startling rapidity that he will be a morose individual indeed who is not aching and crying from laughter at the end of the farce.

"WHEN BROADWAY WAS A TRAIL"

(World Film—Five Reels)

REVIEWED BY PETER MILNE

NOT many pictures have been produced dealing with the city of New York when it was in its infancy, and this offering which takes us back to the days of Peter Minuet, or to be more accurate Henry Minuet, his son, who lived and loved in 1626 or thereabouts, will be warmly received by the motion picture public.

Most New Yorkers and those who have visited the city will take great pleasure in seeing how their forefather's lived in the same locale that now boasts of the only and unparalleled Broadway.

Aside from its freshness in regard to time and place, the picture is plainly the finished effort of a competent director, assisted by an equally competent cast, which he himself leads.



MINUET REFUSES TO DEFEND HIMSELF

O. A. C. Lund is the director, and on the whole he has made an admirable picture, one that is bound to please.

Mr. Lund himself appears as Henry Minuet, the son of Peter, the governor of Manhattan, who after several severe trials and misfortunes is at last happily united with Priscilla, a Puritan maid from Danvers. This character is played by Barbara Tennant, who is well suited to the part.

Peter Minuet is played by Edward Roseman. Salvation Hibbens, Henry's puppy rival is carried off by Lindsay J. Hall. Alec B. Francis in the role of Hope, the mayor of Danvers, is as good as ever. Mary Navarre gives an excellent characterization of the strict Puritanical housewife in the role of Mistress Hibbens. Julia Stuart appears as Mistress Minuet, and George Cowl as the chief of the Iroquois Indians.

The progress of the story is rather slow but hardly ever tiring, and the incidental scenes, the escape from the prison, continued through an underground passage, seething with furious waters, and the attacking and massacring of a band of whites by the redskins, together with a number of others of the same thrilling variety, will not allow the interest to falter.

We have seen better artificial snow—or is it mist—than that which falls in "bunches" in the latter reel, but this seems to be the only fault that the average person will notice. Some of the exterior scenes are obviously sets, but this is quite pardonable, as it would have caused great trouble to erect an entire village.

RICHARDSONS WON BY CALIFORNIA SCENERY

Special to MOTION PICTURE NEWS

Los Angeles, Oct. 19.

THE Richardsons, of the American Film Manufacturing Company, have taken a larger house on Anacapa street, Santa Barbara, Cal., and are finding fresh inspirations in the glorious sunsets, which they are able to see from their studio windows.

Mrs. Richardson says that she never so fully appreciated the beauty of Santa Barbara before.

"A CHANGE OF HEART"

(Pathe—Two Reels)

REVIEWED BY CLIFFORD H. PANGBURN

THIS film presents a fine story which is not new, but in real life is all too rare. This gives it interest, while its value as an attraction is added to by good setting and fine photography.

The events of the story are not such as demand anything spectacular in the line of scenes, but they do require care to obtain natural results. In this the producers have been entirely successful. M. O. Penn and Thurlow Bergen play the principal roles in a creditable manner.

The story tells of a young man of good family who had fallen in with a bunch of get-rich-quick men. They planted a fine office for the purpose of roping in the unwary.

A dear old lady from the country comes and buys her worthless stock with \$5,000, which represents her life savings. The young man is so affected by the old lady's remarks about his mother that he takes her money from his companions at the point of a gun and returns it to her.

"THE PERILS OF PAULINE"

(Eclectic—Two Reels)

REVIEWED BY CLIFFORD H. PANGBURN

MANY and various are the adventures which beset an heiress under any circumstances, but when she is brought into daily contact with a man who will inherit her fortune in case of her death, and who is entirely unscrupulous it is small wonder that her path is beset with danger.

There have been many thrills in the career of Pauline, as already shown on the screen, but in this episode her life is menaced in a new and terrible way. Her desperate enemy makes another of his ingenious attempts to dispose of her in a manner which will leave him entirely free from suspicion.

There are not so many thrilling scenes in this as have occurred in some of the earlier installments. In fact, the only one which is at all out of the ordinary is that in which the hero rides a motorcycle off the end of a pier. However, there is good photographic work, and the acting done by Pearl White is effective. Her part during the time when she is supposed to be a victim of disease is one that is difficult to handle without making it seem ridiculous, but she has avoided that element successfully.



THE DOG KNOWS A VILLAIN

The story relates how Owen had his hired villain steal some disease germs from a laboratory of a specialist. These caused a person infected to seek to submerge himself in water, doubtless causing a mental attitude similar to that of rats after partaking the brand of poison specially provided for them. Owen puts this culture of germs on some of Pauline's candy, and then does all he can to prevent her recovery. He even hires a fake doctor, but Harry wins out and Pauline's life is saved.

Laemmle Family, Stranded in War Zone, Home

Maurice Fleckles, Armed with Passports from High Officials, Penetrates Lines and Rescues Wife and Children of Universal President

PRESIDENT CARL LAEMMLE, of the Universal Film Company, recently received a cablegram from Rotterdam which informed him that Maurice Fleckles succeeded in obtaining the release of Mrs. Laemmle, Mrs. Fleckles and the two Laemmle children, Julius and Rosabelle, who were detained in Germany since the beginning of hostilities.

This greatly relieves the tension, inasmuch as nothing had been heard from them for over a month. The party sailed from Rotterdam on October 15, and arrived in New York on the twenty-fifth on the Holland-American liner, "Rotterdam."

Mr. Fleckles left the office of the Universal nearly a month ago, well supplied with American gold, his mission being to find the Laemmle party, who were in Flieden, the birthplace of Mrs. Laemmle. During his absence no communication reached the anxious relatives on this side, save for a cablegram.

He carried with him passports signed by the American Secretary of State and Haniel Von Haimshausen, charge d'Affaires in Washington, as well as personal letters of introduction from Hon. William Jennings Bryan to the American diplomatic and consular officers of the United States and Europe.

Eaco Films Will Release Through Craft

Strand Film Company Gets Contract, Winik London Agent—Single Reel Comedies and Three-Reel Features Planned—Other Details

THE Eaco Films, with Edwin August as their star, have signed contracts with P. P. Craft, the head of The Apex Film Company, with offices in the West Forty-Fifth Street Exchange Building, New York City, to handle exclusively the Eaco releases in the United States and Canada through the Strand Film Company channels, and likewise with J. Simmonds, who represents Mr. H. Winik, of 35 Little Newport street, London, W., England, who will control the foreign rights.

portrayed a great number of excellent parts at the west coast Universal studios will be featured. Each comedy will be complete in itself, yet each will be connected with the previous one. In the single reel Westerns, a well-known picture artist will play the principal roles.

The Western company will go to California, and Managing Director August with his company and the comedy company, will make Florida their winter quarters.



EDWIN AUGUST IN "A MILLIONAIRE DETECTIVE"
First Release of the Eaco Films through the Strand Film Company

Edwin August, in addition to acting and producing his three reel features, will supervise the production of the single reel Western and comedy companies. Mr. August, who has to his credit over three hundred scenarios, has in mind a series of fifteen comedy scenarios in which Hal August, who

It is also the intention of Mr. August to do down to Bermuda for a series of mythical photoplays in which he will play the principal roles. For special releases, well-known plays and widely read novels will be picturized, in which Mr. August will appear as well as directing the production.

BIARMER LEARNED BUSINESS FROM THE GROUND UP

O. W. Biarmer, of Copenhagen, who made the acquaintance of David Horsley while traveling in this country, and finally became associated with the Centaur Film Company, learned the busi-



O. W. BIARMER

ness from the ground up in the Bayonne, N. J., factory.

He started in the developing room. After that he worked his way through every department, learning every phase of this intricate business.

Later on he was appointed traveling representative of Mr. Horsley and visited every city of importance in the United States and Canada, establishing offices for the Lumiere stock, of which Mr. Horsley holds the American rights.

Returning to New York, Mr. Biarmer was placed in charge of the main office of Lumiere, and during the last year has been sales manager of the commercial department of the Centaur Film Company, whose mammoth plant at Bayonne does a developing, printing and title business amounting to upwards of a million and a quarter feet of film each week.

KELCEY AND SHANNON IN "SALT OF THE EARTH"

Herbert Kelcey and Effie Shannon have been selected by Winthrop Ames to play the leading parts in Alice Brown's prize play, "Salt of the Earth." Those two popular stars are very much in evidence before the public just now in the Photo Drama Company's magnificent production, "After the Ball," taken from Charles K. Harris' famous song and produced under the direction of Pierce Kingsley.

Steiner and Maher report that "After the Ball" receipts surpass all expectations.

INTERESTING FILM REVIEWS

PRODUCTIONS FROM ALL PROGRAMS

GENERAL FILM PROGRAM

"Midst Woodland Shadows." (Vitagraph. Mon., Oct. 12.)—The familiar story of a man from the city who meets and marries an unsophisticated little girl of the mountains. There is the usual rival whose intentions are dishonorable. Anita Stewart and Earle Williams play the leads.

"Maree, the Foster Mother." (Vitagraph. Two reels. Tues., Oct. 13.)—A weak story of a woman who takes such poor care of her foster daughter that she is killed in a fight at a disreputable resort. This is supposed to be self-sacrifice on the part of the older woman. In the cast are Anne Schaefer, Margaret Gibson, Leroy Lederer, William Duncan and George Stanley.

"Swami Sam." (Lubin. Tues., Oct. 13.)—On the same reel with "Neighborly Neighbors." This is a slapstick comedy of a police force which could not arrest a man who proved an easy capture for a negro laundress. John and Mattie Edwards head the cast.

"Neighborly Neighbors." (Lubin. Tues., Oct. 13.)—On the same reel with "Swami Sam." A comedy of errors due to the return of three couples from a visit at the same time. They raid each other's kitchens until troubles come thick and fast.

"The Letter That Never Came Out." (Edison. Tues., Oct. 13.)—A remarkably complicated story for one of its length. A jealous woman brings about the breaking of an engagement. Five years later her own husband suffers as a result, and the lovers end their quarrel. Herbert Prior is seen as the hero.

"The Iron Master." (Biograph. Two reels. Tues., Oct. 13.)—A story which has good intentions but is not presented in a very convincing manner. In spite of this it is not without interest.

"The Fable of How Uncle Brewster Was Too Shifty for the Tempter." (Essanay. Wed., Nov. 4.)—Another of the George Ade series, played by Frank Owens, Uncle Brewster, warned by Aunt Mahaley to be good and not let anyone get his roll, visits the city to pay off a mortgage. Some humorous situations result from his closefistedness. The moral deduced is that "Some are good, because it comes too high to be otherwise."

"The Impostor." (Lubin. Two reels. Thurs., Oct. 15.)—A crooked lawyer searches for the lost heir to a title. Believing the real heir to be dead he tells his story to a young man who resembles him, and takes him back as the heir, planning to share in the estate. His scheme is rather upset when it turns out that the youth is the real heir.

"The Peacemaker." (Vitagraph. Wed., Oct. 14.)—A story of a foolish lovers' quarrel in which an old artist acts as a peacemaker, and all ends well. In the cast are Norma Talmadge, Van Dyke Brooke, Antonio Moreno, Constance Talmadge and Garry McGarry.

"His Dominant Passion." (Vitagraph. Thurs., Oct. 15.)—A story suggesting De Maupassant's "The Diamond Necklace." A man spends twenty years in the penitentiary as a result of stealing some diamonds, only to find on being released that they are paste imitations.

"The First Law." (Biograph. Thurs., Oct. 15.)—A drama which is rather well acted but which is not convincing in its treatment of a rather hackneyed idea.

"Rivalry and War." (Essanay. Mon., Oct. 26.)—Two Germans are the rivals for the hand of the same girl. They wage such fierce warfare for her admiration that their business is neglected. She passes both of them up, goes to Europe and returns to find them partners

in a flourishing business. The old trouble commences again. Wallace Beery, Leo White and Betty Brown play the leads.

"Why the Sheriff Is a Bachelor." (Selig. Tues., Oct. 27.)—This is a Tom Mix picture with plenty of riding and shooting and an interesting story. Tom in the discharge of his duty as sheriff, is compelled to arrest the brother of his sweetheart, whom he is soon to marry. She pleads with him to release her brother but duty compels him to take him to jail. The girl refuses to marry him because of this.

"The Wasp." (Selig. Wed., Oct. 28.)—A detective drama of the "blue flame" variety with some splendid characterizations. It shows how right wins in the end. Some good situations and detective work of an interesting character. "The Wasp," a political boss, tries to besmirch the character of the independent candidate by attacking the character of his son. His plan, however, fails, and he is badly whipped at the polls at election.

"The Grate Impeeryul Sirkus." (Selig. Thurs., Oct. 30.)—A splendid comedy enacted by children trying to imitate the circus playing their town. They do everything that one might expect from a regular circus in an amateur way. Elsie Greeson as the prime mover in this stunt plays a child's part very convincingly. The real elephant finally joins their parade and takes them in free to the big show, followed by a crowd of the villagers who bring prosperity to the tented aggregation.

"At the Transfer Corner." (Selig. Fri., Oct. 31.)—A comedy that finally entangles dad so badly that he is compelled to give his consent to the marriage of his son to what he terms a flirt, and also brings him under the charms of the flirt's mother. The young couple's return from Europe with their "surprise," a baby for their parents, is put over one better by dad who displays a pair of twins.

"The Lost Melody." (Edison. Wed., Oct. 28.)—A touching drama of a musician who is separated from his sweetheart by cruel circumstances. Later they are reunited, when he hears her playing his lost melody which he had composed for her. Realistic staging and good acting.

"The People's Choice Who Answered the Call of Duty and Took Seltzer." (Essanay. Wed., Oct. 28.)—A George Ade comedy with a lot of humor and comic situations. He gets tangled up in politics by a couple of smooth talking bosses and loses all of his money after being assured by the "dream book" that he will win. Thomas Comerford as the politician is all that one might wish in the part.

"Snakeville and the Corset Demonstrator." (Essanay. Thurs., Oct. 29.)—The male inhabitants of Snakeville are all upset by the arrival of a corset demonstrator in their town. The lone bachelor does not find favor with her, so she tells the spouses of the swains that pay court to her. A funny picture with the entire western comedy company, Sophie Clutts, Slippery Slim and all.

"Broncho Billy's Mother." (Essanay. Sat., Oct. 31.)—Broncho Billy, the bad man of the town, terrorizes the village. He is arrested, but his mother arrives as they are to take him to prison and the sheriff pins his star on him. A plot that has been overworked.

"Shorty." (Edison. Tues., Nov. 3.)—A good drama of an attempt to rob a sea captain of a diamond shipment, which is frustrated by a bright cabin boy. There is a touch of excellent comedy supplied by Edward O'Connor. The others in the cast are also good.

"Jenks and the Janitor." (Edison. Wed., Nov. 4.)—On the same reel with one of the Buster Brown comedies. It is a rather entertaining story of a man who gave a suit of his

clothes to the janitor, and as a result the janitor had troubles of his own. May Abbey and Dan Mason are in the cast.

"Getting to the Ball Game." (Edison. Sat., Nov. 7.)—Not a story but a series of events concerning a man who failed to get to the ball field in time.

"With Slight Variations." (Edison. Mon., Nov. 9.)—A rather good burlesque of the round-the-world-in-eighty-days school of story. Terrible cannibals and other wild creatures are introduced. In the cast are Bliss Milford, Cora Williams, Frank Lyons and William Wadsworth.

"The Heritage of Hamilton Cleek." (Edison. Tues., Nov. 10.)—Another of the Cleek series. The detective's bride is kidnapped on her wedding day, but Cleek rescues her. On the same day he learns that he is the heir to a throne, but declines to accept. Ben Wilson and Gertrude McCoy with the usual supporting cast appear.

"A Question of Identity." (Edison. Two reels. Fri., Nov. 13.)—A film version of the novel, "The Window that Monsieur Forgot," by Mary Imlay Taylor. The story is fairly good, but is marred by the large number of variations from anything which could possibly take place under the existing conditions. It will please the average audience. Among those in the cast are William Bechtel, Julia Calhoun, Bessie Learn, Augustus Phillips, Mabel Trunelle, Edward Earle and William West. An innocent man is at first believed guilty of a murder committed by his brother. A third man is sentenced.

"The Bond of Womanhood." (Lubin. Two reels. Wed., Oct. 14.)—Nell, the wife of a wealthy man, leaves him on account of his questionable associates. Mary, the wife of a poor man, is deserted by her drunken brute of a husband. The two women meet through an automobile accident to the former, and a bond of sympathy springs up between them. Unknown to each other, each sets out to try to induce the other's husband to come home and be good. This is finally accomplished with the poor man by appealing to his sense of right and wrong, and with the rich man by giving him the information that he is a father and that his wife is being cared for by strangers. The scenario is by Shannon Fife. Justina Huff and William Cobill are the well-to-do couple, and Joe Smiley and Lillie Leslie are the poor couple. John Smiley and Eleanor Blanchard take character parts. The work of all of these is very good. The photography is hazy in spots.

"Fatty's Sweetheart." (Vitagraph. Fri., Oct. 16.)—A rural comedy utilizing the familiar situation of fake thieves being captured as real ones, and in turn capturing real ones they suppose to be fake. Hughie Mack is Fatty, and others in the cast are Lucille Lee, Tod Talford, Ralph Ince and Charles Eldridge.

"The Long Lane." (Lubin. Fri., Oct. 16.)—A man loses his sweetheart because he is believed dead as a result of his rival's act. Seven years after her marriage her now brutal husband comes to a timely death and she weds her former lover. In the cast are Dolly Larkin, John Francis, William Parones, Joseph Carle and Janic Powell.

"Tell Tale Knife." (Selig. Tues., Nov. 3.)—An exceptionally interesting and well produced Western drama, by Tom Mix, in which the identity of a castle rustler is disclosed through a knife given him by his sweetheart. A pistol fight in a saloon follows. The rustler gets away, only to be run down and killed after a most vivid hair-raising chase. Contains lots of real fighting, and unusually good riding.

"C. D." (Selig. Wed., Nov. 4.)—A very interesting civil war drama of the "Blue Flame" variety. A love story is woven through a United States secret service agent's

exciting experiences in reporting important news by telegraph. Stella Razeto and Guy Oliver play the principal parts.

"No Wedding Bells for Her." (Selig. Fri., Nov. 6.)—Norval MacGregor puts over another very funny comedy-burlesque. After many ridiculously humorous situations the villain dies and justice triumphs. Lee Morris is particularly good in the role of the villain.

"The Losing Fight." (Selig. Sat., Nov. 7.)—Kitty, the belle of a fishing village, runs away from her home and lover to marry Mack Huntley, a new arrival from the city, with whom she has become infatuated. Huntley has the drug habit. He tries to conquer it, but in vain, and a tragic end results. An intensely interesting though rather morbid drama with excellent photography, realistic scenes and good action by Kathryn Williams, Wheeler Oakman, Charles Clary, and Frank Clark.

"Rosemary, That's for Remembrance." (Selig. Two reels. Mon., Nov. 2.)—Dorinda, an orphan, is adopted by the Greers. Their son, Harvey, comes home from college, and falls in love with her. Leaving a sprig of rosemary with Dorinda as a pledge of his faithfulness, Harvey goes to Washington, where he becomes infatuated with a coquetish society girl and entirely forgets his love for Dorinda. An accident shortly after his return home reveals to him the sterling qualities of Dorinda, and he discovers that his love for her is real, while his love for the society girl is merely infatuation. Well produced society drama, featuring Ada Gleason and Edith Johnson.

"The Prison Stain." (Kalem. Two reels. Wed., Nov. 4.)—A man and a girl are released from prison on the same day. They decide to live honestly, and shortly the girl marries her employer. The man obtains a good position, and becomes a business associate of her husband. A dishonest butler steals money from the girl's husband, but her prison friend saves her reputation. It is a story of considerable interest.

"His Inspiration." (Kalem. Two reels. Mon., Nov. 2.)—A composer of popular music thinks he is a world-beater, when it is really his wife who gives him all of his ideas. He becomes infatuated with a vaudeville actress, who accepts his attentions merely to gain publicity. Not until he is reduced to the bread line does he realize his wife's ability. A happy reconciliation takes place. Tom Moore appears in the principal role.

"Lizzie, the Life Saver." (Kalem. Tues., Nov. 3.)—A roaringly funny comedy of the slapstick type. There are many extremely clever and novel touches. The story has to do with a stenographer who, when discharged for flirting, gets a job as a life guard. A pair of quarreling janitors are also concerned. A really funny film, which should please every one.

"His Wedded Wife." (Vitagraph, Mon., Oct. 19.)—An impossible story of a man who marries on what is supposed to be his death bed, recovers, finds the wife, who believes herself a widow, and wins her love. In the cast are Leah Baird, William Humphrey and Rex Hitchcock.

"Anne of the Mines." (Vitagraph. Two reels. Tues., Oct. 20.)—A melodrama of a man who sought to marry a mine superintendent's daughter when already married. When he is exposed he seeks revenge by attempting the life of the girl's sweetheart. He is frustrated and killed. Myrtle Gonzalez, William Duncan and Alfred Vosburgh play the leads.

"Martin Chuzzlewit." (Biograph. Tues., Oct. 20.)—An extremely abridged edition of Dickens's famous novel. Rather well acted, but somewhat disconnected because of the method of treatment.

"Such a Mess." (Lubin. Tues., Oct. 20.)—A burlesque of the type of story in which the son and daughter of two hostile families fall in love. It is rather well done. On the same reel is "Only Skin Deep."

"Only Skin Deep." (Lubin. Tues., Oct. 20.)—On the same reel with "Such a Mess." Two girls, naturally pretty, try to qualify for a widower who wants to marry a homely woman. They try hard, but lose out. In the cast are Mae Hotely, Mabel Paige and Harry Loraine.

"The Laundresses." (Essanay. Mon., Nov. 2.)—A regular Sweedie comedy, in which

Sweedie, the laundress, who is in love with a tailor, learns that the tailor is to dine with a rival. Sweedie writes that she is going to commit suicide, and rigs up a dummy, which she submerges in the dye vat. In the confusion and the complications that follow, she secures a pledge of undying love from the tailor, thereby thwarting the rival.

"Fires of Fate." (Essanay. Tues., Nov. 3.)—A jilted and lonely bachelor rescues a strange girl, in whom he has become interested, from a hotel fire. Of course, they are afterwards married, and live happily in the apartment which the hero had prepared for the girl he had formerly loved. A very realistic and exciting fire scene makes this a most interesting picture of a story adapted from "Munsey's Magazine." It is well acted by Richard Travers and Ruth Stonehouse.

"The Smuggler's Daughter." (Lubin. Sat., Oct. 17.)—A burlesque concerning the adventures of a bold revenue officer who is sent out to track down a hardy band of cheese smugglers. His life is saved by the chief's daughter after he has been sentenced to be fed to death on limburger. In the cast are Raymond McKee, Eva Bell, Babe Hardy, James Levering, Bill Hopkins and John Edwards.

"The Girl in the Case." (Vitagraph. Two reels. Sat., Oct. 17.)—Two officers of a bank attempt to incriminate an innocent cashier to cover their own thefts. They nearly succeed but are foiled by their victim's sweetheart who happens in a most improbable way to learn of their plans. The crooks are sent to prison and the young people are happy. Fairly interesting. In the cast are Thomas R. Mills, Robert Gailford, Estelle Mardo, Logan Paul and Thomas Mack.

"Meeting Mr. Jones." (Biograph. Sat., Oct. 17.)—On the same reel with "Our Home Made Army." It is a moderately funny comedy, but lacks originality.

"Our Home Made Army." (Biograph. Sat., Oct. 17.)—On the same reel with "Meeting Mr. Jones." Also a comedy, but not as good as that picture.

UNIVERSAL PROGRAM

"The Return." (Eclair. Two reels. Wed., Nov. 4.)—A good Western acted by an equally good cast headed by Bob Frazer, Norbert Miles and Edna Payne. Lucie Villa is cast for a human interest part which she carries off well. It develops that the man the young girl marries is the good-for-nothing. The good-for-nothing turns out to be the hero, and the death of the former paves the way for a happy marriage. Exciting action of the Western melodramatic sort. Excellent photography.

"The Lass of Kill'rankie." (Victor. Two reels. Mon., Oct. 26.)—An old story put in a humorous manner, with the principals as Scotch. Father and mother each select the man for their daughter to marry. After many funny situations she marries the man of her own choice. Elsie Albert is the girl.

"The Tale of a Lonesome Dog." (Victor. Fri., Nov. 6.)—How a dog captures a burglar is the interesting story this picture tells. A well trained dog performs. The burglar is dressed like a hobo, and will furnish a little amusement.

"Carmen's Washday." (Sterling. Mon., Oct. 19.)—The Sterling kids start a regular riot in this picture between the older people by careless manipulations of sling shot and bow and arrow. Max Asher appears in a comical role. A chase ends the picture.

"The Fate of Persistent Pete." (Nestor. Tues., Nov. 3.)—A comedy made aboard steamship by the returning McRae players. Count is a most persistent lover, even to jumping overboard. Lots of chasing and action.

"Fools and Pajamas." (Joker. Sat., Nov. 7.)—Not up to Joker standard. The story is not exactly coherent. Two drug salesmen are rivals in love. Neither wins the girl. The best fun is furnished by William Franey and a new comedian, Milburn Moranti.

"The Hoodoo." (Joker. Wed., Nov. 4.)—Ernest Shields assumes the part of such a ridiculous person in this picture that one will be laughing at him throughout, and the story will be forgotten. It is very funny, too, making the whole reel very laughable.

"Those Were the Happy Days." (Nestor. Two reels. Fri., Nov. 6.)—Fine comedy is this, producing many laughs. A little slapstick but not too much. Eddie Lyons and Victoria Forde play the lovers, Lee Moran the spiteful janitor, and Bess Meredith the belle of the school. Father doesn't like his daughter's actor lover, and after they have been secretly married he sends her off to school. Then Eddie comes and poses as a professor, but the janitor spies on him and finally the truth comes out that the couple have been married.

"Lights and Shadows." (Rex. Two reels. Sun., Nov. 8.)—This story is slightly too complicated to make a good picture and too much time is covered. The ending is abrupt and one is left to speculate upon the final outcome. Pauline Bush, Lon Chaney, Beatrice Van and William Dowlan play the leads. After a lengthy introductory we see a young girl who has fallen in love with the leading man of a theatrical company, and after the leading lady has done her best to ruin the love affair, they are seen to depart together in a cab.

"Nan of the Hills." (Powers. Fri., Nov. 6.)—For the reason that the woman once befriended him, the sheriff lets her robber husband go, who was justified in his attempted thievery. Edna Maison leads the cast of this pleasant drama.

"The Mysterious Rose." (101 Bison. Two Reels. Sat., Nov. 7.)—Another one of the "My Lady Raffles" series, with Grace Cunard, Francis Ford and a large supporting cast. All hands are at a loss to know who murdered the district attorney's son, who threatened to kill himself unless My Lady would favor him with her affections. A great fight is staged, as usual most realistic, but the final outcome is left to be supposed.

"Partners in Crime." (L. K. O. Sun., Nov. 1.)—Not as good as it could be, as it is practically incoherent. A good many laughs are produced by the actions of Billy Ritchie, but if the scenes fitted in together there would be more laughs still. Rough slapstick work throughout.

"The Fatal Marriage." (L. K. O. Sun., Nov. 8.)—Two comical gentlemen have rather an ugly woman whom they want to marry to some misguided person, but they are unsuccessful as a younger and prettier girl puts in her appearance and wins the attention of the applicants. A comical chase is the feature of the picture in which some acrobatic work takes place. Rough slapstick action marks the entire reel.

"The Desperado." (Broncho. Two reels. Wed., Nov. 4.)—A picture showing an old mother's devotion for her son even though he is the worst kind of a desperado. The story is put together in an excellent manner, and acted splendidly, so that suspense and interest are always kept at the highest.

"Stout Heart But Weak Knees." (Keystone. Sat., Oct. 24.)—Charles Murray and the uproarious Keystone police are the chief fun makers in this reel. They are fun makers in every sense of the word and the picture will keep one in continual laughter.

"Shot in the Excitement." (Keystone. Mon., Oct. 26.)—We don't know just exactly where the "excitement" is, but from the picture it could be taken that it is any part of the human anatomy. Shooting, falling and throwing consume the greater part of the picture, and will create all manner of laughter, especially when a ridiculously slow canon ball is seen pursuing a runaway couple.

"Left in the Train." (Thanouser. Sun., Oct. 18.)—The reconciliation of the girl and her father comes when the former's child is left in the train and is brought to the father by his two grand nieces. A very pretty story in which the Thanouser twins and the kidlet play important parts.

"Secret Service Snitz." (Sterling. Thurs., Oct. 22.)—Amusing burlesque on the moonshiner-secret service agent story. Ford Sterling is Snitz. Very laughable. The film seems lightstruck in parts.

"Persistent Lovers." (Crystal. Tues., Oct. 27.)—The plot of this comedy is secondary to the events that transpire at Coney Island, New York. The principals sporting themselves on the various contrivances that the Island boasts of, makes a humorous reel, which could be better.

(Continued on page 63.)

STERLING Motion Picture CAMERA

Price No. 2.....\$350
Including Instruction.

This is a practical Professional Camera fitted with Zeiss Tessar Lens, patent adjustable dissolving shutter and aperture plate operated from outside of camera case, equipped with 4-500 ft. magazine.

STERLING CAMERA & FILM CO.
145 W. 45th St., New York City, N. Y.
Bryant 8064

AFTER THE BALL THE LITTLEST REBEL SHOULD A WOMAN TELL

Are great box office attractions which need no introduction. Book them now.

Photoplay Productions Releasing Co.
37 S. Wabash Ave. Chicago

ARE YOU HAVING BOOKING TROUBLE?

Are you getting the films you want—or are paying for?

Save trouble, time and money by booking your films through the

Managers Booking Bureau

Suite 1012, Hartford Building, Chicago
PHONE—CENTRAL 2448

Motion Picture Booking for the States of Illinois, Indiana and Michigan.

Films Reviewed.
Exhibitors' Supply Service.

Information regarding any branch of the Motion Picture business.

Write now for particulars.

SPECIAL 10 DAY SALE

We will close out 10 Standard Make No. 4 Viascope Moving Picture Machines, complete, just as good as new, at a bargain price of \$52.50 each.

WESTERN FILM BROKERS,
Powers Bldg. Chicago, Ill.

REDUCE YOUR EXPENSES

Use Corcoran Tank System

Get Price List No. 6

A. J. CORCORAN, Inc.

9½ John Street New York

A. L. Runyon Advertising & Sales Co., Inc., Successors to



Prices to The Trade

POSITIVE PRINTS .04½ Per Foot
(In Quantities over 5000 feet)

Above price includes printing, developing, tinting, toning and Raw Positive

Negative Film Developed .01 Per Ft.

Film Titles .08 " "

(Our Special Title Apparatus will match any perforation.) All work guaranteed.

General Offices, 2624 Milwaukee Ave., Chicago
Phone Albany 3125

GOVERNMENT INSTALLS 60 POWERS MACHINES

That the practical value of the motion picture is thoroughly appreciated by the various departments of the United States Government has been amply proved by the use made of it in many ways. No departments make more extensive use of the screen, however, than do those of the Army and Navy.

In those two departments alone, there have been installed over sixty Powers Cameragraph motion picture projection machines. They have been placed at West Point and at Annapolis, in the principal army posts throughout the country, and on a number of battleships, where they are used not only for entertainment purposes, but for instruction in military and naval tactics. Among the most recent of these installations have been machines on the battleships Utah and Montana.

ROSKAM HAS NARROW ESCAPE IN AUTO ACCIDENT

While Edward M. Roskam, president of the Life Photo Film Corporation, was driving along the Palisades with the superintendent of the laboratory, Charles Hirliman, his automobile became unmanageable and skidded, sending the two thousand pound machine over a ten-foot embankment.

Luckily the machine did not turn turtle, and Mr. Hirliman, with presence of mind, shut off the motor, stopping the machine ten feet from the edge of the Palisades.

Although the machine is a total wreck, neither Mr. Roskam nor Mr. Hirliman received any injuries.

Mr. Roskam says he now owes his life, as well as the wonderful laboratory work the Life Photo Film Corporation and the Commercial Motion Pictures Company are obtaining, to Charlie.

KEYSTONE SIGNS SYD CHAPLIN

Syd Chaplin, the English comedian and brother of Charles Chaplin (the funny drunk), of Keystone fame, has signed up with the Keystone Company. He recently left New York for the Los Angeles studios. Mr. Chaplin is sure to be a great success with the Keystone Company, as he has been star comedian and producer for Fred Karno, London, for the past eight years.

Max Stern, who has been for several years with the American Booking Offices of New York, has been appointed road representative of the World Film Corporation's Pittsburgh branch.

Make Your Lobby Display Attractive

There is nothing more fascinating to the public than a bright brass frame to display your photos or posters.

We make Lobby and Theatre Fixtures and Brass Rails of every description.

Don't fail to visit our Showrooms.

Write for catalog.
THE NEWMAN MFG. CO.

717 Sycamore St.
Cincinnati, Ohio
Branch Factories and Show Rooms:
101 Fourth Ave.
New York, N. Y.
106-108 W. Lake St.
Chicago, Ill.
Established 1882.



THE CHEAPEST PLACE

TO BUY BEST QUALITY

ROLL TICKETS

IS

The Pioneer Ticket Co.

722 Broadway, New York

Perfect Numbering Quick Delivery

There Are Several

interesting business boosting schemes outlined in the "Live Wire Exhibitors" department of this issue. It will pay you to read every one of them.

Lantern Slide Mat Co.

Manufacturers of

Lantern Slide Mats and Reel Bands

Prompt Service

Prices Right

Best Goods

149 W. 35th St., New York

Telephone: Greeley 6414

WE CAN EQUIP YOUR THEATRE COMPLETE

We are Distributors for the Powers, Edison, Motiograph and Simplex Machines, and Genuine parts, also Poster Frames, Indirect and Semi-Indirect Lighting Fixtures, Tickets, Screens, etc.

We sell for cash or on the easy payment plan.

Write today for our new catalog just off the press.

AMUSEMENT SUPPLY COMPANY, 160 No. Fifth Avenue, Chicago, Illinois

Save 35%
on your
CARBONS
Burn your stubs
with a
**CARBON
Economizer**

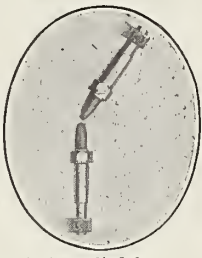

Pat. applied for.

Fits any lamp, gives perfect contact and conductivity, screw does not come in contact with carbon and will not weld to body of economizer, will burn Upper or Lower carbon from 6 inches to 3/4 of an inch.

**NOW IN USE—632—NOW IN USE
"MECHANICALLY CORRECT"!!
GUARANTEED TO GIVE SATISFACTION**

\$1.25 Sizes \$2.00
Each. 1/2"-5/8"-3/4" Upper & Lower Set.
Sent Postpaid upon receipt of draft,
money order or cash.

THE CARBON ECONOMIZER CO.
757 W. Onondaga St. Syracuse, N. Y.

Moving Picture Scenarios

We are in the market
for one and two reel
comedies and comedy
dramas.

Submit in typewritten
form to

J. C. BROWNELL
105 Lawrence Avenue, Dept. C,
Dorchester, Mass.

Holland Film Manufacturing Co.

Your negative developed, printed and titled complete

5c delivered **12** hours
per foot within

Titles **6c** per foot

GUNBY BROS., Inc.
145 West 45th Street New York City

Our Factory Is Yours!

Negative assemblers, projecting
machines and an equipment second
to none, with an organization of ex-
perienced people always at your
SERVICE for DEVELOPING and
PRINTING.

EVANS FILM MFG. CO.
Incorporated

416-22 WEST 216th STREET
Tel. 7652 Audubon at Broadway, New York

**Sometimes
A Name**

is misspelled, or a street
number is incorrectly copied
from subscription forms. If
the wrapper containing your
copy of the News each week is
incorrectly addressed in any
detail, please advise us. It
will remove any chance of error
or delay in delivery.

INCORPORATIONS

**MONTAUK FILM PRODUCING COM-
PANY**, general moving pictures; \$5,000;
Manhattan. Thos. L. W. Evans, John P. Mc-
Connell and John W. Harms, of New York.

**REGENT FILM MANUFACTURING
COMPANY**, manufacturing and deal in mo-
tion pictures, films or dramas; \$5,000; Man-
hattan. Henry A. Strongman, Stanleigh P.
Friedman and Rae London, of New York.

**AMERICAN AND EUROPEAN FILM
COMPANY**, \$10,000; Manhattan. Will Stet-
son, Grace L. Percheau and John L. Lytelle,
of New York.

**EMANESS AMUSEMENT CORPORA-
TION**, theatrical, motion picture and public
amusement business; Manhattan; \$5,000.
Fannie and Max Spiro, Elias Mayer and two
others, of New York.

CONTINENTAL ENTERPRISES, INC.,
general theatrical and dealer in motion pic-
tures; \$250,000; Buffalo. Alfred R. Sherry,
Henry R. Crowder, Jno. G. Lessing and two
others.

**A-T-M-O-S-P-H-E-R-I-C SCREEN COM-
PANY, INC.**, manufacturing screen for mo-
tion pictures, particularly "The A-t-m-o-
s-p-h-e-r-i-c"; \$10,000; Manhattan. Gustave
Schacht, Wm. A. Schacht, Abraham Lipsches
and two others.

**CLARENDON PHOTOPLAY CORPORA-
TION**, motion picture business, etc.; \$15,000;
Kings County. William H. Kemble, Roland
W. Baiter, Chas. W. G. Bader and two others
of New York.

BRYANT PHOTO-PLAY COMPANY,
motion pictures; \$5,000; Manhattan. Wm.
Youst, Jno. Koenig and Ernest Luhrs.

CHALIA OPERA COMPANY, INC.,
theatrical, motion pictures, etc.; \$25,000;
Manhattan. George S. Abbott, Lydia G.
Fuhrmann and Rosalia C. Herrera, of New
York.

**FILM RENTAL BROKERS OF NEW
YORK**, motion pictures, etc.; \$1,000; Man-
hattan; W. Joy Delamater, Jno. L. Lytelle
and Richard Smith, of New York.

IOLA PHOTOPLAY COMPANY, INC.,
conduct theatres and moving picture shows;
\$3,000; Brooklyn. John Brown, Anton
Gronich and Abraham Frank, of Brooklyn.

FEDERATED FILM CORPORATION;
\$10,000. A. Hovey, E. Bulwinkel, J. M.
Flynn, 126 West 46th Street, Manhattan.

**MONTGOMERY MOORE FILM COR-
PORATION**; \$10,000. A. Canter, U. S.
Hill, H. B. Dantziger, 316 West 93d Street,
Manhattan.

**INTERNATIONAL MOON SCREEN
COMPANY**, cinematograph screens, films;
\$10,000. E. Stein, M. Kowinsky, E. Mueller,
207 East 52d Street, Manhattan.

**EUROPEAN FILM DEVELOPING
COMPANY, INC.** General motion picture
business; \$20,000. Manhattan. T. K.
Schwartzah, Herman Horowitz and Henry C.
Siemers, of New York.

PRISMATIC FILM COMPANY, INC.
Motion pictures, etc.; \$400,000. Manhattan.
George C. Leavitt, George F. Leavitt, of New
York; Chas. C. Field, of Brooklyn, and two
others.

SAFARI FILM CORPORATION. Pho-
tography and motion pictures; \$5,000. Man-
hattan. Louis Wills, John C. Hemment, Ly-
man N. Nine, and one other, of New York.

**LEADING PHOTO-PLAY EXHIBIT-
ORS, INC.** Motion picture business; \$2,500.
Manhattan. Lee A. Ochs, Milton M. Gold-
smith and Charles M. Rosenthal, of New
York.

**TREBLE CLEF MOTION PICTURE
CO., INC.** Motion picture and theatrical;
\$10,000. Manhattan. Louis Bernstein, Allan
A. Deutch, Lazarus Cohen and one other, of
New York.

GIBALTAR FILMS, INC. Motion pic-
ture; \$100,000. Manhattan. Sydney Dalton,
Herman Lingg, George Fleming and two others.

At Chicago, Ill.:

AUSTEN AMUSEMENT COMPANY,
Chicago; capital, \$2,500; theatre and amuse-
ment business; incorporators, M. J. Mintz,
Florence Hutcherson, Morris G. Leonard.

**COMER TALKING MOTION PICTURE
COMPANY**, Chicago; capital, \$10,000; man-
ufacturing, lease, operate and deal in sound
reproducing apparatus, motion picture pho-
tographers, films, etc.; incorporators, John J.
Comer, Frank Mayer, Guy Van Schoick.



**BE
NEUTRAL**
PRES. WILSON
**DON'T BURN
POWDER
"BURN
CARBONS"
Burn 'em Up
SHORT**
with
WEBB'S CARBON SAVER

Cut one half size

Extra heavy and best material used throughout
PRICE \$1.00 EACH PREPAID
Ask about our Terminals.
MOTION PICTURE SPECIALTY & REPAIR CO.
326 3d Ave. Pittsburgh, Pa.

COPYRIGHTS secured on films; photo-
plays; music; sketches; art works.
TRADE MARKS registered.
PATENTS, PROCESS, mechanical and
electrical, secured. Free advice given.
JOSEPH J. O'BRIEN,
215 M'Gill Bldg. Washington, D. C.



**World
Film
Corporation**
Presents
a Blaney Photoplay Feature

**"ACROSS
THE
PACIFIC"**

RELEASED NOV. 2

Arrange Bookings on
this feature through

WORLD FILM CORPORATION
LEWIS J. SELZNICK, Vice Pres. &
Gen'l Mgr.
130 WEST 46TH ST., NEW YORK.
26 Branches Throughout the U. S. &
Canada.

LANG'S FILM REELS
THE BEST MADE
14 in. \$1.50 10 in. \$1.00
CATALOGUE
LANG MFG. WORKS, Orleans, N. Y.

NO WAR BOOST ON OUR PRICES

Regardless of the present European unpleasantness
we continue to use all essential chemicals such as
METOL AND HYDROQUINONE
and consistently maintain standard prices for quality
DEVELOPING AND PRINTING
Send today for our price, quality and service guarantee.

INDUSTRIAL MOVING PICTURE CO. 223-233 West Erie Street, Chicago

What Do You Need?

LISTING IN THE BUYERS' GUIDE, FOR NAME AND ADDRESS, INCLUDING ONE YEAR'S SUBSCRIPTION TO THE MOTION PICTURE NEWS—\$2.00 A YEAR, CASH IN ADVANCE. FREE TO ADVERTISERS USING \$100.00 OR MORE WORTH OF DISPLAY SPACE DURING THE YEAR. ADDRESS ADVERTISING DEPARTMENT

ADVERTISING NOVELTIES

Philip Hano, 806-810 Greenwich St., New York.

ANNOUNCEMENT SLIDES

Niagara Slide Co., Lockport, N. Y.

ASBESTOS BOOTHS

Sharlow Bros., 442 W. 42nd St., New York.

CLEANING AND RENOVATING FILM

Film Redeveloping Co. of America, 145 W. 45th St., N. Y.
 Multicolor Film Improving Co., Inc., 15 E. 26th St., N. Y.

COSTUMERS

Miller-Costumier, 236 South 11th St., Philadelphia, Pa.

DEVELOPING TANKS

A. J. Corcoran, Inc., 9½ John St., New York.

ELECTRIC LIGHTING SETS

The Chas. A. Strelinger Co., Box P-2, Detroit, Mich.

FILMS

(Manufacturers, Dealers and Renters)
 American Film Mfg. Co., Chicago, Ill.
 Thomas A. Edison, Inc., 275 Lakeside Ave., Orange, N. J.
 Essanay Film Mfg. Co., First National Bank Bldg., Chicago, Ill.
 General Film Co., 200 Fifth Ave., New York.
 George Kleine, 166 N. State St., Chicago, Ill.
 Lubin Mfg. Co., Philadelphia, Pa.
 G. Melies, 204 E. 38th St., New York.
 Mutual Film Corp., 71 W. 23rd St., New York.
 New York Motion Picture Corp., Longacre Bldg., New York.
 Pathé Freres, 1 Congress St., Jersey City, N. J.
 Renfax Film Co., Inc., 110 W. 40th St., N. Y.
 Selig Polyscope Co., Chicago, Ill.
 Thanhouser Film Corp., New Rochelle, N. Y.
 Universal Film Mfg. Co., 1600 Broadway, N. Y.

FILM ACCESSORIES

Berlin Aniline Works, 213 Water St., N. Y.

FILM TITLES, PRINTING, DEVELOPING, ETC.

Commercial Motion Pictures Co., Inc., 220 W. 42nd St., New York.
 Centaur Film Co., 670-682 Ave. E, Bayonne, N. J.
 Evans Film Mfg. Co., 412-22 W. 216th St., at Broadway, New York.
 Gunby Bros., Inc., 145 W. 45th St., New York.
 Industrial Moving Picture Co., 223-233 W. Erie St., Chicago.
 Standard Motion Picture Co., 5 S. Wabash Ave., Chicago.
 Standard Filmprint Corp., 120 School St., Yonkers, N. Y.

FILM REELS

Lang Mfg. Works, Olean, N. Y.
 Taylor-Shantz Company, 224 Mill St., Rochester, N. Y.

FURNITURE AND FURNISHING ON RENTAL

William Birns, 103-105 West 37th St., N. Y.

FEATURE FILMS

Alco Film Corp., 218 W. 42d St., New York.
 Alliance Films Corp., 126 W. 46th St., New York.
 Albuquerque Film Mfg. Co., Inc., 406 Court St., Los Angeles, Calif.
 All Star Feature Corp., 220 W. 42nd St., N. Y.
 Ambrosio American Co., 15 E. 26th St., N. Y.
 Bosworth, Inc., 640 N. Olive St., Los Angeles, Cal.
 Box Office Attraction Film Rental Co., 130 W. 46th St., New York.
 A. Blinkhorn, 110 W. 40th St., New York.
 California Motion Picture Corp., San Francisco, Cal.

Cosmofotofilm Co., 110 W. 40th St., New York.
 Cosmos Feature Film Corp., 126-130 W. 46th St., N. Y. City.

Direct-From-Broadway Features Co., 46 W. 24th St., New York.

Eclair Film Co., 126 W. 46th St., New York.
 Eclectic Film Co., 110 W. 40th St., New York.
 Excelsior Feature Film Corp., Inc., 110 W. 40th St., N. Y.

G. W. Feature Film Corp., 145 W. 45th St., N. Y.

Features Ideal, 126 W. 46th St., New York.
 Famous Players Film Co., 213-229 W. 26th St., New York.

Films Lloyds, Inc., 220 W. 42nd St., N. Y.
 General Film Co., 200 Fifth Ave., New York.
 General Feature Film Co., 313 Mallery Bldg., Chicago, Ill.

Gaumont Co., 110 W. 40th St., New York.
 Greene's Feature Photo Plays, Inc., 110 W. 40th St., New York.

W. W. Hodgkinson, 110 W. 40th St., New York.
 Imperial Motion Picture Co. of N. Y., Inc., 1476 Broadway, N. Y.

Inter-Continent Film Co., 110 W. 40th St., New York.
 George Kleine Attractions, 166 N. State St., Chicago, Ill.

New York Office: 1476 Broadway.
 Jesse L. Lasky Feature Play Co., Longacre Theatre, New York.

Life Photo Film Corp., 220 W. 42nd St., N. Y.
 Mecca Feature Film Co., Inc., 126 W. 46th St., New York.

Mohawk Film Co., Times Bldg., New York.
 Oz Film Mfg. Co., Santa Monica Blvd., Los Angeles, Cal.

Paramount Pictures Corp., 110 W. 40th St., New York.
 Phoenix Feature Film Corp., 129-131 Columbus Ave., Boston, Mass.

Photo Play Production Co., 220 W. 42nd St., New York.
 Picture Playhouse Film Co., 110 W. 40th St., New York.

Playgoers Film Co., Lyric Theatre, New York.
 Popular Plays and Players Co., 1600 Broadway, New York.

Progress Film Co., 110 W. 40th St., New York.
 Progressive Motion Picture Corp., Times Bldg., New York.

Ramo Films, Inc., Columbia Theatre Bldg., New York.
 Rolands Feature Film Co., 145 W. 45th St., New York.

A. H. Sawyer, Inc., 1600 Broadway, New York.
 Select Photo Play Producing Co., Inc., 71 W. 23rd St., New York.

Sterling Camera & Film Co., 145 W. 45th St., New York.
 Solax Co., Fort Lee, N. J.

The Masterpiece Film Mfg. Co., 1111 Van Nuys Bldg., Los Angeles, Cal.
 The Photoplay Productions Releasing Co., 37 S. Wabash Ave., Chicago, Ill.

Union Features, 126 W. 46th St., New York.
 Universal Film Mfg. Co., 1600 Broadway, N. Y.

University Films, Inc., 110 W. 40th St., N. Y.
 Edw. H. Wagner, Agt., Dania Biofilm Co., 38 Park Place, N. Y.

World Film Corporation, 130 W. 46th St., New York.
 Warner's Features, Inc., 130 W. 46th St., N. Y.

LANTERN SLIDE MATS AND REEL BANDS

Lantern Slide Mat Co., 149 W. 35th St., N. Y.

LABELS

Every Ready Roll Label Co., 203-7 W. 40th St., New York City.

LIGHTING PLANTS

Cushman Motor Works, Lincoln, Neb.

LOBBY PHOTOS

The Wyanoak Pub. Co., 136 W. 52nd St., N. Y.

MOTION PICTURE MACHINES AND SUPPLIES

Amusement Supply Co., 160 E. North Fifth Ave., Chicago, Ill.

Calehuff Supply Co., 1301 Race St., Philadelphia, Pa.

Enterprise Optical Co., 568 W. Randolph St., Chicago, Ill.

Lears Theatre Supply Co., Sam Lears, Prop., 509 Chestnut St., St. Louis, Mo.

Oliver Moving Picture Supply Co., 647 Euclid Ave., Cleveland, O.

Picture Theatre Equipment Co., 21 E. 14th St., New York.

Precision Machine Co., 317 E. 34th St., N. Y.

Nicholas Power Co., 90 Gold St., New York.

The Phantascope Mfg. Co., Washington, D. C.

Sweetley's Photo Supply House, 514-516 Erie Ave., Renova, Pa.

Williams, Brown & Earle, Inc., 916-918 Chestnut St., Philadelphia, Pa.

MOTION PICTURE APPARATUS

Burke & James, Inc., 240-258 E. Ontario St., Chicago, Ill.

MUSICAL INSTRUMENTS

American Photo Player Co., 62 W. 45th St., New York City.

Rudolph Wurlitzer Co., Cincinnati, O.

POSTER AND PICTURE FRAMES

Menger & Ring, 442 W. 42nd St., New York.

RAW FILM

Eastman Kodak Co., Rochester, N. Y.

Celluloses Planchon, Inc., 75 Fifth Ave., New York.

David Horsley, 1600 Broadway, N. Y.

Raw Film Supply Co., 15 E. 26th St., N. Y.

OPERA CHAIRS

The Hardesty Mfg. Co., Canal Dover, Ohio.

Steel Furniture Co., Grand Rapids, Mich.

PIPE ORGANS

Henry Pilcher's Sons, 914-920 Mason Ave., Louisville, Ky.

M. P. Moller, Hagerstown, Md.

PROJECTION LENSES

Bausch & Lomb Optical Co., 569 St. Paul St., Rochester, N. Y.

POSTERS

The Morgan Lithograph Co., Cleveland, Ohio.

REWINDERS AND GENERAL SUPPLIES

L. C. Smith Co., Schenectady, N. Y.

SCREENS

Atsco, Inc., 218 West 42nd St., New York.

Day & Night Screens, Inc., 110 W. 40th St., New York.

Mirror Screen Co., Inc., Shelbyville, Ind.

STEEL FILM EQUIPMENT FOR EXCHANGES AND MFERS.

Columbia Metal Box Co., 226-228 E. 144th St., New York.

TICKETS—ROLL AND COUPON

Rees Ticket Co., 400 S. 10th St., Omaha, Neb.

THEATRE LOBBY FRAMES AND FIXTURES

Newman Mfg. Co., 715 Sycamore St., Cincinnati, O.

UNIFORMS

Fechheimer Bros., Union-made Uniforms, Cincinnati, O.

VENTILATION, COOLING AND HEATING

Typhoon Fan Co., 1544 Broadway, N. Y.

To Wyanoak Pub. Co.
136 West 52nd St., New York City

Name.....

At your expense send complete information about your coupon plan to the above address.

FOLD OVER AND TEAR OFF HERE

This Coupon Will Help You to Pack Your Theatre

You don't believe it?
Very well then!

Is it worth one cent to find out?

Both the General and Universal endorse us and give us the exclusive right to this plan.

That establishes our honesty and business worth!

You need do nothing but tear off the coupon—corner of page and all—stick it on a post card and mail to us: or slip it in an envelope if easier.

We will do the rest! Send you complete information about our coupon plan. It's a business builder based on human interest and we back you up—not only at the start—but right thru to a big finish.

**WYANOAK PUB. CO.
136 West 52nd Street
NEW YORK CITY**

Your Operator Can't Help It

Neither can the maker of your glass announcement slides—they are bound to break!

Our Patented Brass Slides Are Absolutely Indestructible—cannot crack.

They project a neat, clear, easily read announcement, and will last for years.

More than 90 stock designs. Special slides to order.

Stock slides, 25 cents each.

For sale at all branches of the General Film Co., Inc., and all Mutual Film Co.'s Exchanges and all Live Dealers and Glass Slide Manufacturers.

Patented Serial No. 757689



Stock Slides, 25c.

Patented Serial No. 757689



Open Space Slides, 35c.

Patented Serial No. 757689



Clock Slides, 50c.

BEHREND MOTION PICTURE SUPPLY HOUSE

440 Fourth Ave. Branch: 71 W. 23rd St.
New York City
SEND FOR COMPLETE LIST

A clear picture

is as essential as a good scenario. Because the basic product is right the clearest pictures are on Eastman Film. Identifiable by the stencil mark in the margin.

EASTMAN KODAK CO.,
ROCHESTER, N. Y.

"SHORE ACRES"

with CHARLES A. STEVENSON

JAMES A. HERNE'S

MASTERPIECE

IN FIVE PARTS

ADAPTED FOR A PHOTO-PLAY BY
LOUIS REEVES HARRISON

PRODUCED BY
AUGUSTUS THOMAS

RELEASED THROUGH
ALCO FILM CORPORATION



THE TRUE NEW ENGLAND CLASSIC

Filled with the atmosphere of the Northern Atlantic Coast. A happy sunshiny play that will bring your patrons back a second time.

ALL STAR FEATURE CORPORATION

EXECUTIVE OFFICES
220 W. 42nd ST., NEW YORK

STUDIOS AND LABORATORIES
FORT LEE, NEW JERSEY

Coming: DIGBY BELL in "THE EDUCATION OF MR. PIPP"



Record of Current and Coming Releases

GENERAL FILM PROGRAM

RELEASES OF THE WEEK

Monday, October 19, 1914.

BIOGRAPH—Their Soldier Boy, D., 1001.....	16229
EDISON—The Adventure of the Smuggled Diamonds, D., 1000.....	16235
ESSANAY—She Landed a Big One, C., 1000.....	16237
KALEM—The Mad Mountaineer, D., 1800.....	16230
LUBIN—The Golden Hope, Beloved Adventurer No. 6, D., 1000.....	16238
SELIG—The Blue Flame, D., 2000.....	16232
SELIG—Hearst-Selig News Pictorial No. 67, N., 1000.....	16236
VITAGRAPH—His Wedded Wife, D., 1000.....	16234

Tuesday, October 20, 1914.

BIOGRAPH—Martin Chuzzlewit, D., 1045.....	16247
COLUMBUS—Love Charm, C., 1000.....	16245
EDISON—The Man In the Dark, D., 1000.....	16239
ESSANAY—Mother O' Dreams, D., 1000.....	16240
KALEM—A Wise Rube, C., 1000.....	16246
LUBIN—Such a Mess, C., 400.....	16244
Only Skin Deep, C., 600.....	
SELIG—Jimmy Hayes and Muriel, D., 1000.....	16241
VITAGRAPH—Anne of the Mines, D., 2000.....	16242

Wednesday, October 21, 1914.

EDISON—Two's Company, C., 1000.....	16249
ESSANAY—The Fable of "The Long Range Lover and the Lollypalooze," C., 1000.....	16252
KALEM—The False Guardian, D., 2000.....	16250
LUBIN—The Hopeless Game, D., 2000.....	16255
SELIG—The Rajah's Vacation, C., 1000.....	16254
VITAGRAPH—Under False Colors, C., 1000.....	16253

Thursday, October 22, 1914.

BIOGRAPH—They Called It "Baby," C., 498.....	16257
His Loving Spouse, C., 501.....	
ESSANAY—Slippery Slim, the Mortgage and Sophie, C., 1000.....	16258
LUBIN—Her Mother Was a Lady, D., 2000.....	16259
SELIG—Hearst-Selig News Pictorial No. 68, N., 1000.....	16262
VITAGRAPH—The Mill of Life, D., 1000.....	16261

Friday, October 23, 1914.

BIOGRAPH—A Woman's Folly, D., 998.....	16271
EDISON—Bootle's Baby, D., 2000.....	16263
ESSANAY—The Private Officer, D., 2000.....	16265
KALEM—Micky Flynn's Escape, C., 1000.....	16267
LUBIN—The Girl in the Tenement, D., 1000.....	16270
SELIG—A Tonsorial Leopard Tamer, C., 1000.....	16268
VITAGRAPH—A Costume Piece, C., 1000.....	16269

Saturday, October 24, 1914.

BIOGRAPH—The Broken Rose, D., 996.....	16278
EDISON—Buster Brown's Uncle, C., 500.....	16272
A Question of Clothes, C., 500.....	
ESSANAY—Broncho Billy-Favorite, D., 1000.....	16273
KALEM—The Demon of the Rails, D., 1000.....	16277
LUBIN—The Crooks, C., 1000.....	16274
SELIG—The Tragedy That Lived, D., 1000.....	16279
VITAGRAPH—Goodbye Summer, D., 2000.....	16275

RELEASES OF NEXT WEEK

Monday, October 26, 1914.

BIOGRAPH—The Squashville School, C., 540.....	16280
The Villainous Uncle, C., 460.....	
EDISON—Wood B. Wedd and the Microbes, C., 1000.....	16286
ESSANAY—Rivalry and War, C., 1000.....	16288
KALEM—The Lynbrook Tragedy, D., 2000.....	16281
LUBIN—The Holdup, the Beloved Adventurer Series, D., 1000.....	16289
SELIG—Playing with Fire, D., 2000.....	16284
SELIG—Hearst-Selig News Pictorial No. 69, N., 1000.....	16287
VITAGRAPH—The Cave Dwellers, C., 1000.....	16285

Tuesday, October 27, 1914.

BIOGRAPH—The Ticket-of-Leave Man, D., 2027..	16299
EDISON—The Mystery of the Sealed Art Gallery, D., 1000.....	16290
ESSANAY—An Unplanned Elopement, D. 1000..	16291
COLUMBUS—Mulligan's Ghost, C., 1000.....	16296
KALEM—The No-Account Count, C., 1000.....	16297
LUBIN—Love and Title, C., 400.....	16295
She Married for Love, C., 600.....	
SELIG—Why the Sheriff Is a Bachelor, D., 1000..	16292
VITAGRAPH—The Butterfly, C., 2000.....	16293

Wednesday, October 28, 1914.

EDISON—The Lost Melody, D., 1000.....	16300
ESSANAY—The Fable of "The People's Choice Who Answered the Call of Duty and Took Seltzer," C., 1000.....	16303
KALEM—The Menace of Fate, D., 2000.....	16301
LUBIN—The Mountain Law, D., 2000.....	16306
SELIG—The Wasp, D., 1000.....	16305
VITAGRAPH—William Henry Jones' Courtship, C., 1000.....	16304

Thursday, October 29, 1914.

BIOGRAPH—The Wife's Stratagem, D., 999.....	16308
ESSANAY—Snakeville and the Corset Demonstrator, C., 1000.....	16309
LUBIN—The Wolf's Daughter, D., 2000.....	16310
SELIG—Hearst-Selig News Pictorial No. 70, N., 1000.....	
VITAGRAPH—Kidding the Boss, C., 1000.....	16312

Friday, October 30, 1914.

BIOGRAPH—The Tides of Sorrow, D., 997.....	16322
EDISON—The Midnight Ride of Paul Revere, D., 2000.....	16314
ESSANAY—Whatever a Woman Soweth, D., 2000.....	16316
KALEM—Ham and the Villain Factory, C., 1000..	16318
LUBIN—Thumb Prints and Diamonds, D., 1000..	16321
SELIG—The Grate Impeeryul Sirkus, C., 1000.....	16319
VITAGRAPH—Bunny Backslides, C., 1000.....	16320

Saturday, October 31, 1914.

BIOGRAPH—Hearts of Gold, D., 999.....	16329
EDISON—The Hand of Iron, D., 1000.....	16323
ESSANAY—Broncho Billy's Mother, D., 1000.....	16324
KALEM—The Vengeance of Winona, D., 1000.....	16328
LUBIN—The Soubrette and the Simp, C., 400.....	16325
An Interrupted Nap, C., 600.....	
SELIG—At the Transfer Corner, C., 1000.....	16330
VITAGRAPH—Within an Ace, D., 2000.....	16326

TRADE CONDITIONS REVIEW SHOWS HEALTHY PROSPERITY THROUGHOUT COUNTRY

(Continued from page 29.)

Pictures Cut Into Seattle Vaudeville

Special to MOTION PICTURE NEWS

Seattle, Oct. 19.

THE motion picture condition in Seattle as compared with last May is much more favorable. Patronage is better, houses that were having a hard time to "get by" at that time are now paying nicely, and those that were doing well then are doing almost as well as before.

One thing stands out prominently, and that is the fact that no catch-penny schemes, country store ideas or free admission stunts of any kind are used by any of the theatres here, and there are no cut-throat policies used either as to prices charged for admissions or in the number of reels used or number of changes per week.

All of the first-class houses; in fact, all of the regular downtown theatres, are changing bills but twice weekly and showing just five reels of film. That, of course, does not include a few "store shows" who change oftener and run old stuff at a nickel.

Two theatres are changing but once a week, running each program for seven days at the rate of eight shows daily. These two theatres are using Paramount programs and getting 20 cents downstairs and 10 cents in the balcony, both afternoon and evening. Five specially-constructed neighborhood shows charge a dime and change four times a week.

Exhibitors claim that the quality of all of the regular programs has decreased. The main objection seems to be that the stories are either impossible or the dramatic interest is lacking. A good two-part drama seems hard to get as a regular thing. A lack of good, clean-cut comedies is complained of.

The exchanges do absolutely nothing for the theatres except supply the film.

Another thing that has its effect on the regular theatre is the fact that the two legitimate houses are in the habit of showing feature films on "dark" weeks.

Motion picture patronage has cut into the vaudeville business as well as the legitimate to a very noticeable extent.

Exhibitors seem to feel that the features are held too high by the exchanges. GEO. H. BELLMAN.

Baltimore Theatres Unite to Raise Prices

Special to MOTION PICTURE NEWS

Baltimore, Oct. 21.

THE first steps toward a general advance in the price of admission to motion-picture theatres to 10 cents, in Baltimore, has been taken by a number of the leading theatres in the centre parts of the city.

Ten of the most prominent shopping district theatrical managers have entered into an agreement by which they agree to charge 10 cents each Saturday. This agreement goes into effect on Saturday, October 24. It is generally felt that the plan will be a huge success, but in order to hold those who may become dissatisfied with the proposition, the agreement binds the exhibitor to charge 10 cents for four consecutive Saturdays only, to give the plan a fair tryout.

There are only two theatres in the shipping district which charge 10 cents admission every day. Several of the larger houses that have not been included in the agreement above mentioned have been running a special Saturday show for which 10 cents has been charged.

Many of the exhibitors have felt for a long time that with the advanced price in film rentals, as well as material used in operating picture houses, it is necessary, in order to give the best production on the market, to charge an increased admission. It is felt here that the advance in Saturday's increased admission will be followed in the very near future by a general increase in price for the entire week.

With this move on the part of the picture exhibitors, it makes a much more attractive field in Baltimore for the special feature proposition. Practically every house that charges ten cents will book special features on Saturday.

THE ALBUQUERQUE FILM MFG. COMPANY, Inc.

Featuring that clever
Comedienne

Miss Dot Farley

Two Comedies Weekly

RELEASING THROUGH
The United Motion Picture Producers, Inc.
WHO DISTRIBUTE THROUGH
Warner's Features, Inc.

By request from many exchanges
we take pleasure in
reviving the

FRONTIER TWIN STORIES

Written and made famous by Miss Dot
Farley. Under direction of
Gilbert P. Hamilton

Farce Comedy Production
BY

ARCHER McMACKIN

Nuf Sed

WESTERN STUDIO
406 Court St. Los Angeles, Calif.
GILBERT P. HAMILTON, Pres. and Gen. Mgr.

RECORD OF CURRENT AND COMING RELEASES—Continued

UNIVERSAL PROGRAM RELEASES OF THE WEEK

Monday, October 19, 1914.

IMP—Country Innocence, D., 2000.....
STERLING—The Mistaken Bath House, C.....
VICTOR—Rice Industry in the U. S., E.....

Tuesday, October 20, 1914.

CRYSTAL—Vivian's Transformation, C.....
GOLD SEAL—The Trey O' Hearts, Episode No.
12, D., 2000.....
NESTOR—The Nihilists, D.....

Wednesday, October 21, 1914.

ANIMATED WEEKLY—No. 137, N.....
ECLAIR—The Violinist, D., 2000.....
JOKER—The Countless Count, C.....

Thursday, October 22, 1914.

IMP—Universal Boy in "The Gates of Liberty"....
REX—Olaf Erickson, Boss, D., 2000.....
STERLING—Secret Service Snitz, C.....

Friday, October 23, 1914.

NESTOR—Cupid Pulls a Tooth, and Educational..
POWERS—Suspended Sentence.....
VICTOR—The Bride of Marblehead, D., 2000.....

Saturday, October 24, 1914.

101 BISON—My Lady Raffles in The Mysterious
Hand, D., 3000.....
FRONTIER—The Scarecrow's Secret, D.....

Sunday, October 25, 1914.

ECLAIR—Smallpox on the Circle U, C.....
L. KO—Love and Surgery, C., 2000.....
REX—The Little Blonde Lady, D.....

RELEASES OF NEXT WEEK

Monday, October 26, 1914.

IMP—Marie's Patients and Educational.....
STERLING—Snoopee's Day Out, C., 1000.....
VICTOR—Terrence O'Rourke No. 1, His Heart,
His Hand, His Sword, D., 2000.....

Tuesday, October 27, 1914.

CRYSTAL—Persistent Lovers, C.....
GOLD SEAL—The Trey O' Hearts, Episode
No. 13, D., 2000.....
NESTOR—The Wall of Flame, D.....

Wednesday, October 28, 1914.

ANIMATED WEEKLY—No. 138, N.....
ECLAIR—The Mystery of Grayson Hall, D., 2000.
JOKER—Noads Adless Day, C.....

Thursday, October 29, 1914.

IMP—In Self-Defense, D., 2000.....
REX—White Roses, D.....
STERLING—A Race for a Bride, C., 1000.....

Friday, October 30, 1914.

NESTOR—When Bess Got in Wrong, C.....
POWERS—The Senator's Lady, D.....
VICTOR—The Witch Girl, D., 2000.....

Saturday, October 31, 1914.

101 BISON—A Daughter of the Red Skies, D.,
2000.....
JOKER—When Their Wives Joined the Force, C..
FRONTIER—The Blacksmith's Daughter, D.....

Sunday, November 1, 1914.

ECLAIR—At the Crucial Moment, D., 1000.....
L-KO—Partners in Crime, C.....
REX—The Vagabond, D., 2000.....

MUTUAL PROGRAM RELEASES OF THE WEEK

Monday, October 19, 1914.

AMERICAN—Daylight, D., 2000.....
KEYSTONE—Dash, Love and Splash, C., 1000.....
RELIANCE—Our Mutual Girl No. 40.....

Tuesday, October 20, 1914.

BEAUTY—Dad and the Girls, C.....
MAJESTIC—Environment, D.....
THANHOUSER—Old Jackson's Girl, D., 2000.....

Wednesday, October 21, 1914.

AMERICAN—In the Open, D.....
BRONCHO—Shorty and Sherlock Holmes, C., 2000
RELIANCE—Out of the Deputy's Hands, D.....

Thursday, October 22, 1914.

DOMINO—The Power of the Angelus, D., 2000....
KEYSTONE—Love Siege, C., 1000.....
MUTUAL WEEKLY—No. 95.....

Friday, October 23, 1914.

AMERICAN—The Final Impulse, D.....
KAY BEE—The Spark Eternal, D., 200.....

Saturday, October 24, 1914.

KEYSTONE—Stout Heart But Weak Knees, C.,
1000.....
RELIANCE—A Blotted Page, D., 2000.....
ROYAL—Harry's Toupee, C.....

Sunday, October 25, 1914.

KOMIC—Bill Joins the W. W. W.'s No. 9, C.....
MAJESTIC—A Flight for a Fortune, D., 2000.....
THANHOUSER—Mr. Cinderella, D.....

RELEASES OF NEXT WEEK

Monday, October 26, 1914.

AMERICAN—Sir Galahad of Twilight, D., 2000....
KEYSTONE—Shot in the Excitement, C., 1000....
RELIANCE—Our Mutual Girl No. 41.....

Tuesday, October 27, 1914.

BEAUTY—A Rude Awakening, C.....
MAJESTIC—A Mother's Influence, D.....
THANHOUSER—A Madonna of the Poor, D.,
2000.....

Wednesday, October 28, 1914.

AMERICAN—Sweet and Low, D.....
BRONCHO—The Golden Goose, D., 2000.....
RELIANCE—Sheriff for an Hour, D.....

Thursday, October 29, 1914.

DOMINO—Eric the Red's Wooing, D., 2000.....
KEYSTONE—.....
MUTUAL WEEKLY—No. 96.....

Friday, October 30, 1914.

KAY BEE—The Worth of a Life, D., 2000.....
PRINCESS—The Dead Line, C.....
RELIANCE—The Availing Prayer, D.....

Saturday, October 31, 1914.

KEYSTONE—.....
RELIANCE—The Wrong Prescription, D., 2000...
ROYAL—Phil's Vacation, C.....

Sunday, November 1, 1914.

KOMIC—Casey's Vendetta, C.....
MAJESTIC—Paid with Interest, D., 2000.....
THANHOUSER—Shep's Race with Death, D.....

"WHATSOEVER A WOMAN SOWETH"

(Essanay—Two Reels)

REVIEWED BY C. J. VERHALEN

ONE of those photoplays with a world of human interest in which the entire action lays very close to nature. As the film unwinds you become more and more engrossed. The story is compelling and makes you wait anxiously each coming incident.

It has none of the melodramatic in it, but is a clean, wholesome tale which might happen in every-day life. It has its sympathetic moments when you feel a lump rising in your throat. That part of the story which is contained in the first reel strikes you as being a strong man's play, showing his ambition, his sympathy for his fellow man.

The second reel continues along the same line but brings out the characteristics of a woman to a greater degree. Gerda Holmes plays a splendid part in her interpretation of Pauline. Her acting, always admirable, is brought out more strongly in its finer parts in this role.

Richard Traverse, in the part of Robert Caldwell, plays a splendid role in a convincing manner.

The date of the marriage of Pauline Marlowe and Robert Caldwell has been set. A few days before the wedding, Robert's father is proven to be an embezzler, and it is a great question in Pauline's mind whether she shall marry Robert, despite the fact that his name is blackened, or whether she should face the comments of the unsympathetic public.

She decides to turn from him and afterwards marries another, only to find that her married life is unhappy.

WILL PUT ON ALL BRADY-SHUBERT FEATURES

Special to MOTION PICTURE NEWS

Buffalo, N. Y., Oct. 20.

ANNOUNCEMENT is made by Manager C. B. McKibben, of the World Film corporation that the Regent and Victoria will in the future show all the Brady-Shubert features. The Strand will present all these attractions first in Buffalo.

TITLES

Our *Title Department* has been re-organized, elaborately equipped and placed under the direction of recognized experts.

Its highly perfected apparatus, lino-type machine and job presses enable us to produce the most difficult title work in any language—artistically, accurately and *quickly*—and at *lower prices* than have ever yet been quoted.

DEVELOPING AND PRINTING

Save money and insure the best results by entrusting your work to the *largest and most complete commercial plant in America.*

CENTAUR FILM CO.

Bayonne, N. J., and 1600 Broadway, N. Y.

Don't Be Alarmed About
CARBONS

Unscrupulous speculators are still shouting "CARBON FAMINE" and trying to scare exhibitors into paying as high as fifteen dollars per hundred for 5/8 x 12 carbons—an increase of over four hundred per cent.

We have endeavored to protect you against this extortion by offering to divide our limited stock at the old prices among those shows which were in danger of closing, but our announcement probably did not reach every one.

We are beginning to get returns from our increased equipment and by the time this goes to press, we will be in position to take care of all exhibitors who are short on carbons, if they do not come at us too strong.

We have made no advance in price, but we reserve the right to cut any order to five hundred or less in case our stock does not warrant filling larger orders.

National Carbon Company
CLEVELAND OHIO

Get The Full Value You
Pay For

Your operator knows only too well the value of a really efficient lens equipment in pleasing patrons of the films. That's why so many of them insist upon

Bausch and Lomb
Projection Lenses

Scientifically computed to portray every detail on the film and insure brilliancy of illumination to the extreme corners.

Bausch & Lomb objectives are regularly supplied with the Edison and Nicholas Power machines and procurable at all exchanges.

Send for interesting free booklet for owners and operators.

Bausch & Lomb Optical Co.
569 ST. PAUL STREET ROCHESTER, N. Y.

RELEASE DATES FOR READY REFERENCE

GENERAL FILM PROGRAM

BIOGRAPH

10-19. Their Soldier Boy, D.....1001
 10-20. Martin Chuzzlewit, D.....2045
 10-22. They Called it "Baby," C.....498
 His Loving Spouse, C.....501
 10-23. A Woman's Folly, D.....998
 10-24. The Broken Rose, D.....996
 10-26. The Squashville School, C.....540
 The Villainous Uncle, C.....460
 10-27. The Ticket-of-Leave Man, D.....2027
 10-29. The Wife's Stratagem, D.....999
 10-30. The Tides of Sorrow, D.....997
 10-31. Hearts of Gold, D.....999

COLUMBUS

10- 8. Kissing Germ, C.....250
 10-13. Why Snakeville Went Dry, C.....1000
 10-20. Love Charm, C.....1000
 10-27. Mulligan's Ghost, C.....1000

EDISON

10-27. The Mystery of the Sealed Art Gallery, D.....1000
 10-28. The Lost Melody, D.....1000
 10-30. The Midnight Ride of Paul Revere, D.....2000
 10-31. The Hand of Iron, D.....1000
 11- 3. Shorty, D.....1000
 11- 4. Jenks and the Janitor, C.....500
 Buster Brown, C.....500
 11- 7. Getting to the Ball Game, C.....1000
 11- 9. With Slight Variations, C.....1000
 11-10. The Heritage of Hamilton Cleek, D.....1000
 11-13. A Question of Identity, D.....2000
 11-14. The Everlasting Triangle, D.....1000
 11-16. The Adventures of the Lost Wife, C.....1000
 11-17. A Moment of Madness, D.....1000
 11-18. Buster Brown and the German Band, Cart.....400
 A Millinery Mix-Up, C.....600
 11-20. What Could She Do? D.....3000
 11-21. Dickson's Diamonds, D.....1000
 11-23. His Chorus Girl Wife, D.....1000
 11-24. A Gypsy Madcap, D.....1000
 11-25. The Temple of Moloch, D.....1000
 11-27. The King's Move in the City, D.....2000
 11-28. The Last of the Hargroves, D.....1000
 11-30. Wood B. Wedd Goes Snipe, C.....1000

ESSANAY

10-17. Broncho Billy Rewarded, D.....1000
 10-19. She Landed a Big One, C.....1000
 10-20. Mother o' Dreams, D.....1000
 10-21. The Fable of "The Long Range Lover and the Lalyplooze," C.....1000
 10-22. Slippery Slim, the Mortgage and Sophie, C.....1000
 10-23. The Private Officers, D.....2000
 10-24. Broncho Billy—Favorite, D.....1000
 10-26. Rivalry and War, C.....1000
 10-27. An Unplanned Elopement, D.....1000
 10-28. The Fable of "The People's Choice Who Answered the Call of Duty and Took Seltzer," C.....1000
 10-29. Snakeville and the Corset Demon-strator, D.....1000
 10-30. Whatsoever a Woman Soweth, D.....2000
 10-31. Broncho Billy's Mother, D.....1000

KALEM

10-12. The Girl and the Stowaway, Alice Joyce Series, C.....2 parts
 10-13. Percy Pimpernickel—Soubrette, C.....1000
 10-14. Seed and the Harvest, D.....2000
 10-16. Si's Wonderful Mineral Spring, C.....1000
 10-17. From Peril to Peril, D.....1000
 10-19. The Mad Mountaineer, D.....1800
 Hesant Buys an Auto, Cartoon.....200
 10-20. A Wise Rube, C.....1000
 10-21. The False Guardian, D.....1000
 10-23. Micky Flynn's Escapade, C.....1000
 10-24. The Demon of the Rails, D.....1000
 10-26. The Lynbrook Tragedy, Alice Joyce Series, D.....2 parts
 10-27. The No-Account Count, C.....1000
 10-28. The Menace of Fate, D.....2 parts
 10-30. Ham and the Villain Factory, C.....1000
 10-31. The Vengeance of Winona, D.....1000
 10-26. The Lynbrook Tragedy, D.....2000

10-27. The No-Account Count, C.....1000
 10-28. The Menace of Fate, D.....2000
 10-30. Ham and the Villain Factory, C.....1000
 10-31. The Vengeance of Winona, D.....1000

KLEINE

9-29. A Shot from Ambush, D.....2000
 10- 6. The Wrecked Special, D.....2000
 10-13. On the Battle Line, D.....2000

LUBIN

10-20. Such a Mess, C.....400
 Only Skin Deep, C.....600
 10-21. The Hopeless Game, D.....2000
 10-22. Her Mother Was a Lady, D.....2000
 10-23. The Girl in the Tenement, D.....1000
 10-24. The Crooks, C.....1000
 10-26. "The Holdup," the Adventurer Series, No. 7, D.....1000
 10-27. Love and Title, C.....400
 She Married for Love, C.....600
 10-28. The Mountain Law, D.....2000
 10-29. The Wolf's Daughter, D.....2000
 10-30. Thumb Prints and Diamonds, D.....1000
 10-31. The Soubrette and the Simp, C.....400
 An Interrupted Nap, C.....600
 11- 2. The Beloved Adventurer, Series No. 8, D.....1000

RELEASE DAYS

GENERAL FILM PROGRAM

Monday—Biograph, Edison, Essanay, Hearst-Selig News Pictorial, Kalem, Pathé, Selig, Vitagraph.
 Tuesday—Edison, Essanay, Geo. Kleine, Pathé, Lubin, Melies, Selig, Vitagraph.
 Wednesday—Edison, Essanay, Kalem, Lubin, Melies, Selig, Pathé, Vitagraph.
 Thursday—Biograph, Essanay, Hearst-Selig News Pictorial, Lubin, Melies, Pathé, Selig, Vitagraph.
 Friday—Edison, Essanay, Kalem, Selig, Pathé, Lubin, Vitagraph.
 Saturday—Biograph, Edison, Essanay, Kalem, Lubin, Pathé, Vitagraph, Selig.

UNIVERSAL PROGRAM

Monday—Victor, Imp, Powers.
 Tuesday—Gold Seal, Crystal, Nestor.
 Wednesday—Nestor, Joker, Eclair, Animated Weekly.
 Thursday—Imp, Rex, Frontier, Sterling.
 Friday—Nestor, Powers, Victor.
 Saturday—Joker, Frontier, 101 Bison.
 Sunday—Rex, Crystal, Eclair, L-K.O.

MUTUAL PROGRAM

Monday—American, Keystone, Reliance.
 Tuesday—Beauty, Majestic, Thanhouser.
 Wednesday—American, Broncho, Reliance.
 Thursday—Domino, Keystone, Mutual Weekly.
 Friday—Kay-Bee, Majestic, Princess.
 Saturday—Keystone, Reliance, Royal.
 Sunday—Majestic, Komic, Thanhouser.

11- 3. The Boomerang Swindle, C.....1000
 11- 4. The Sorceress, D.....2000
 11- 5. The Stolen Yacht, D.....2000
 11- 6. Love Triumphs, D.....1000
 11- 7. Kidnapping the Kid, C.....400
 The Honor of the Force, C.....600
 11- 9. The Beloved Adventurer, Series No. 9, D.....1000
 11-10. Butt-Ing In, C.....400
 A Bargain Table Cloth, C.....600
 11-11. The Quack, D.....2000
 11-12. In the Hill of Kentucky, D.....2000
 11-13. The Trap, D.....1000
 11-14. Beating the Burglar, C.....400
 Magazine Cooking, C.....600

MELIES

9-15. The Tramp's Revenge, C.....1000
 9-17. The Seah Waiter, C.....1000
 9-22. The \$1,000 Pants, C.....1000
 9-24. How Clarence Got His, C.....1000
 9-29. A Circus Romance, C.....900
 10- 1. Blind Marriage, C.....1000

PATHE

8-24. Edible Fishes of the English Channel, E.....550
 Picturesque Normandy, France, T.....500

8-25. Rapids and Falls at Trondhjen, T. 300
 Picturesque France, Lower Brittany, T.350
 From Havre to Buc by Hydro-aeroplane, T.350
 8-26. Pathé's Daily News, No. 54, N.....1000
 8-31. Pathé's Daily News, No. 55, N.....1000
 9- 2. Pathé's Daily News, No. 56, N.....1000

SELIG

10-13. The Mexican, D.....1000
 10-14. The Mysterious Beauty, C.....1003
 10-15. Hearst-Selig News Pictorial, No. 66, N.....1000
 10-16. The Man-Hater, C.....1000
 10-17. The Woman of It, D.....1000
 10-19. The Blue Flame, D.....2000
 10-19. Hearst-Selig News Pictorial No. 67, N.....1000
 10-20. Jimmy Hayes and Muriel, D.....1000
 10-21. The Rajah's Vacation, C.....1000
 10-22. Hearst-Selig News Pictorial No. 68, N.....1000
 10-23. A Tonsorial Leopard Tamer, C.....1000
 10-24. The Tragedy That Lived, D.....1000
 10-26. Playing with Fire, D.....2000
 10-26. Hearst-Selig News Pictorial No. 69, N.....1000
 10-27. Why the Sheriff Is a Bachelor, D.....1000
 10-28. The Wasp, D.....1000
 10-29. Hearst-Selig News Pictorial No. 70, N.....1000
 10-30. The Grate Impeeryul Sirkus, C.....1000
 10-31. At the Transfer Corner, C.....1000

VITAGRAPH

10-14. The Peacemaker, C.....1000
 10-15. His Dominant Passion, D.....1000
 10-16. Fatty's Sweetheart, C.....1000
 10-17. The Girl in the Case, D.....2000
 10-19. His Wedded Wife, D.....1000
 10-20. Anne of the Mines, D.....2000
 10-21. Under False Colors, C.....1000
 10-22. The Mill of Life, D.....1000
 10-23. A Costume Piece, C.....1000
 10-24. Good-bye Summer, D.....2000
 10-26. The Cave Dwellers, C.....1000
 10-27. Underneath the Paint, D.....2000
 10-27. The Butterfly, C.....2000
 10-28. William Henry Jones' Courtship, C.....1000
 10-29. Kidding the Boss, C.....1000
 10-30. Bunny Backslides, C.....1000
 10-31. Within an Ace, D.....2000
 10-26. The Cave Dwellers, C.....1000
 10-27. The Butterfly, C.....2000
 10-28. William Jones' Courtship, C.....1000
 10-29. Kidding the Boss, C.....1000
 10-30. Bunny Backslides, C.....1000
 10-31. Within an Ace, D.....2000

UNIVERSAL PROGRAM

ANIMATED WEEKLY

10-21. No. 137, N.....
 10-28. No. 138, N.....
 11- 4. Weekly No. 139, N.....

101 BISON

10-24. My Lady Raffles in "The Mysterious Hand," D.....3000
 10-31. A Daughter of the Red Skies, D.....2000
 11- 7. A Small Town Girl, D.....3000

CRYSTAL

10-13. Oh, You Gypsy Girl and Som Collecter, C.....
 10-20. Vivian's Transformation, C.....
 10-27. Persistent Lovers, C.....1000
 11- 2. They Didn't Know, C.....

ECLAIR

10-18. The Quarrel, D.....
 10-24. The Squatter, D.....3000
 10-21. The Vicar, D.....2000
 10-25. Smallpox on the Circle U, D.....
 10-28. The Mystery of Grayson Hall, D.....2000
 11- 1. At the Crucial Moment, D.....1000
 11- 4. The Return, D.....2000
 11- 8. At the Crucial Moment, D.....

INTERESTING FILM REVIEWS

(Continued from page 52.)

"Universal Bog, No. 9." (Imp. Thurs., Nov. 5.)—Another adventure of Matty. Quite as good as those that have gone before, and possessing a story the outcome of which is well concealed.

"Snopee's Day Off." (Sterling. Mon., Oct. 26.)—Snopee is henpecked and when he sees an attractive young woman disporting herself on the beach in an abbreviated bathing suit, we can excuse him in his attempt to roll his wife's bathroom into the water, but he gets the wrong house and the girl goes instead. Funny in parts, risqué in others, with a few vulgar moments.

"Let Us Have Peace." (Rex. Two reels. Thurs., Nov. 5.)—Universal's second appeal for peace is serio-humorous, dealing with an old Frenchman and his live-long neighbor, a German. They almost come to blows over the war, but are prevented by their children, who are in love. The titles are written in the two dialects. The story would be better if condensed. Ben Wilson and Frances Nelson are the lovers.

"The Wall of Flame." (Nestor. Tues., Oct. 27.)—The forest fire scenes in this picture are excellent and the rescue of the wife of the ranger effected by the husband makes a fine story. Murdock MacQuarrie and Agnes Vernon are in the leads.

"White Roses." (Rex. Thurs., Oct. 29.)—In which, after many battles, the spirit of the White Roses, which represent Virtue, triumphs over Evil. This drama is entirely different from most and will be enjoyed. Ella Hall and Alan Forest play the leads, supported by Harry Carter as the Devil.

"The Blacksmith's Daughter." (Frontier. Sat., Oct. 31.)—Not much development to this drama. Fred at length wins the hand of the blacksmith's daughter despite the efforts of another to bully him from attempting.

"When Bess Got In Wrong." (Nestor. Fri., Oct. 30.)—Lee Moran and Bess Meredith play the leads in this comedy, which contains less slapstick work than is usual with this brand. Lee teaches his sweet-heart to stop flirting by telling all his acquaintances to keep away from her. Very laughable and well acted.

"Noad's Address Day." (Joker. Wed., Oct. 28.)—Ernest Shields in the leading part will create a bit of humor. He assumes the part of a man much adverse to advertising. In his dreams he discovers how valuable advertising is.

"A Daughter of the Redskins." (101 Bison. Two reels. Sat., Oct. 31.)—Played by William Clifford, Marie Walcamp, Sherman Bainbridge and Val Pal. The old Indian and his daughter are driven from the village because he will not consent to his daughter's marriage to Wanana, the chief. Later the girl's father is killed by a bandit, and she thinks that her lover did the deed, which leads to a fight between him and Wanana, in which the latter is victorious and lays claim to the girl.

"In Self-Defense." (Imp. Two reels. Thurs., Oct. 29.)—A well constructed story directed by Herbert Brenon and played by William Shay, Violet Mercereau, Hobart Henley and William Welsh. Beautiful scenes taken on and around a lake mark this production. Billy, a detective, is engaged; his fiancée is insulted by Tom, a gambler. He is pursued and drowned by her brother. Billy gets on the job and finally Hobart confesses the crime; he is allowed to go free when his story is told. A noticeable inconsistency is a dead man breathing deeply.

MUTUAL PROGRAM

"Sweet and Low." (American. Wed., Oct. 28.)—A little child finds an old man on a park bench. She reminds him of his little girl, lost many years ago, at the time of his wife's death, while he was away in the gold fields of Alaska. The child takes the old man home, where, of course, he discovers his own

long lost daughter, as the mother of the little girl. A touching story, with especially good juvenile acting. William Garwood and Vivian Rich are the principals.

"A Rude Awakening." (Beauty. Tues., Oct. 27.)—The husband is cured of night life and made to appreciate his wife by a dream in which she is changed from a severe domestic individual into a coquettish lady, who proves the center of attraction in the cafe and gambling room.

"Max's Money." (Royal. Sat., Nov. 7.)—A good comedy of a butler who inherits a fortune. A detective is looking for him to tell him the news on behalf of a lawyer, but as Max has stolen some money, he tries to avoid the officer. Louis Simon is the principal.

"Back to the Kitchen." (Majestic. Fri., Oct. 16.)—The familiar story of a French chef attempting to pass himself off as a count. Rather well done, however, and containing many funny scenes. Dorothy Gish is the girl whose hand is sought by the fake nobleman.

"The Revenue Officer's Deputy." (Reliance. Two reels. Sat., Oct. 17.)—A young man who is accused of cowardice proves that he is by no means lacking in courage when a real test comes. He is an assistant of a revenue officer who is attempting to run down some moonshiners.

"Environment." (Majestic. Tues., Oct. 20.)—A youth spends his time with a company of crooks and thieves. As a result of his environment he is unable to get work, and is easily persuaded to start a career of crime. That his end is not worse is not his fault.

"In the Open." (American. Wed., Oct. 21.)—A story of a cowman and Mexicans in the old days. A young ranch owner seeing a pretty Mexican girl being whipped by her stepfather rescues her, and then rescues her again when her relative makes off with her. Vivian Rich and William Garwood are featured.

"For Her Father's Sins." (Majestic. Two reels. Sun., Oct. 18.)—A department store owner's daughter leaves home to become a working girl after her father refuses to listen to her plea on behalf of his employees. She meets a settlement worker with whom she falls in love, and later reunites him with his lost sister. At risk of her life she saves the girl from death. Later she prevails upon her father to change his ways. There is a strong cast, including Billie West, Blanche Sweet, Wallace Reid and Al Fillson.

"Out of the Deputy's Hands." (Reliance. Wed., Oct. 21.)—A sheriff finds that the man he is looking for is in love with the same girl whom he admires, but later discovers that he had shot a man for attacking the girl. He resigns as sheriff, and goes away without making any arrest. Florence Crawford and Arthur Mackley are featured.

"The Touch of a Little Hand." (Princess. Fri., Oct. 16.)—The old but entertaining story of a hard hearted old man being warmed and changed because of a little girl; in this case his change of heart frees an innocent young man from jail. Boyd Marshall and Mayre Hall play the lovers.

"Our Mutual Girl, No. 40." (Reliance. Mon., Oct. 19.)—A view of New York from the roof of the Flatiron Building starts this reel; later Margaret visits Mrs. Simcox' establishment and inspects the latest in fashions. In the meantime the mystery of Baby Lily and the precious pin is cleared.

"The Black Hand." (Royal. Sat., Oct. 17.)—Good comedy of the man who employs the Black Hand to kill him. Later he decides that he wants to live, and when a man who has been fixing the stove leaves "black hand" marks all over the house, his fears will be apt to strike one as humorous.

"Old Jackson's Girl." (Thanouser. Two reels. Tues., Oct. 20.)—This is a Western in which the characters are hardly well enough introduced to warrant great interest in their actions. The murderer who has thrown the blame on an innocent man is apprehended at length and killed. The sheriff's posse laying siege to a cabin in which the innocent man is hiding is a good series of scenes.

"The Love Thief." (Keystone. Thurs., Oct. 22.)—Chester Conklin appears in this sidesplitter, in a very comical role. The sit-

uations he plunges himself into are exceptionally humorous and will call for rounds of laughter.

"The Friend." (Domino. Two reels. Thurs., Nov. 12.)—A story dealing with the rapid rise of an artist's model in the social world and her even more rapid descent to the dregs of society, due to an artist disclosing her past. Splendidly acted, but not for children to see.

"Destiny's Night." (Broncho. Two reels. Wed., Nov. 11.)—A crook story but of a different nature and more pleasing than most in which two crooks are led to reform through the confidence placed in them by a beggar woman. Acted absorbingly by a good cast.

"The Gentleman of Nerve." (Keystone. Thurs., Oct. 29.)—Charles Chaplin, Chester Conklin and Mabel Normand attending an auto race. Results? As laughable as ever were pictured.

WARNER'S FEATURES

"Prince Charlie." (Superba. Sun., Nov. 8.)—A laughable offering with Charlie De Forest in his well known comic role. As a sailor Charlie is cast adrift on an island inhabited by humorous appearing savages. After going through a number of funny experiences he arrives home, just in time to keep his wife from marrying another.

"Won by Cooking."—Quite the contrary. The son wants to marry a young actress, and as his father is in need of a cook, persuades her to pose as such. Her cooking is not much to boast of, and the old man in sheer desperation gives in to his son's wishes. There is a good bit of humor in this reel and many laughs will be the result.

"His Wedding Day."—On this eventful day the young groom is pursued by his creditors and gets into all manner of difficulties which are for the most part funny. Finally, his worthless stocks turn out to be good, and he is married amidst great rejoicing.

"Soul Mates." (Albuquerque.)—A merry little farce in which Dot Farley and Buck Connors are the principals. Two homely creatures masquerade in good clothes, and get married before they have seen each other.

"As a Man Chooses." (Premier.)—The action is slightly too slow. The white man who has married an Indian decides to return to his former sweetheart, but on second thought sees that it is his duty to remain with the Indian.

"The Green Eyed Monster." (Klarks Comics.)—The ravings of a jealous husband constitute the major portion of this reel. He attacks an innocent man and accuses him of flirting with his wife. Quite a little humor in this.

"Slim and the Mummy." (U. S. Film Corporation.)—Slim has to take the mummy's place and is buried by the boys as a joke. Aside from the fact that the print shown seems slightly light struck this is a very desirable comedy.

"For His Brother's Crime." (Warners.)—The rustler's brother takes his place and goes to prison in his stead for the love of the miscreant's wife. This is a fast western and boasts of excellent photography.

"Nearly an Artist."—To win the girl's father over to his side the young man poses as an artist. The situations that follow will be liable to strike all as humorous.

"The Vegetarians."—Before marrying the girl her lover wins her over from vegetarianism in a way which might be comical if the principals were better performers.

"A Modern Sampson."—An old man swears never to shave until his party is in office. His prospective son-in-law shaves him for a joke and thereafter he is taken for a hobo until the other explains the situation. Rather humorous.

"The Imposters."—After an elopement the two young people are reconciled with the girl's father in a way that is quite comical. They go as caretakers for a house but when the mistress leaves they give a party. The mistress turns out to be the old man's sweetheart so all ends well.

RELEASE DATES FOR READY REFERENCE—Continued

FRONTIER

10—11. Dolly's Deliverance, D.....
 10—18. In the Hollow of an Oak, D.....
 10—24. The Scarecrow's Secret, D.....
 10—31. The Blacksmith's Daughter, D.....
 11— 7. The Girl from Texas, D.....

GOLD SEAL

10—20. Trey o' Hearts, Episode No. 12, D.....
 10—27. The Trey o' Hearts, Episode No. 13, D.....
 11— 3. The Trey O' Hearts, No. 14, D.....

IMP

10— 8. Universal Boy in "Rural Adventures," D.....
 10—12. Mary's Convert, Reissue, D.....
 10—15. The Futility of Revenge, D.....
 10—19. Country Innocence, D.....
 10—22. Universal Boy in "The Gates of Liberty"
 10—26. Marie's Patients, and Educational; split reel.....
 10—29. In Self-Defense, D.....
 11— 2. The Turn of the Tide.....
 11— 5. The Universal Boy in "The Mystery of the New York Docks".....

JOKER

10— 3. In the Clutches of the Villain, C.....
 10— 7. The Baseball Fan in Fanville, C.....
 10—10. Cruel, Cruel World, C.....
 10—14. On Again, Off Again, Finnigan, C.....
 10—17. Across the Court, C.....
 10—21. The Countess Court, C.....
 10—28. Noads' Adless Day, C.....
 10—31. When Their Wives Joined the Force, C.....
 11— 4. The Hoodoo, and Educational.....

L-KO

11— 8. The Fatal Marriage, C.....

NESTOR

9—25. Fruits and Flowers, C.....
 9—30. The White Wolf, D.....
 10— 2. Out of the Frying Pan, C.....
 10— 7. The Old Bell Ringer, D.....
 10— 9. He Never Said a Word, C.....
 10—16. The Way of Life, D.....
 10—23. Cupid Pulls a Tooth, and Mt. St. Bernard, Switzerland; split reel.....
 10—27. The Wall of Flame, D.....
 11— 3. The Boy Major, D.....
 11— 0. Those Were the Happy Days, C.....

POWERS

10— 2. The Actress, D.....
 10— 9. The Mayor's Manicure, C.....
 10—16. The Padrone's Ward, D.....
 10—23. Suspended Sentence, C.....
 10—30. The Senator's Lady, D.....
 11— 6. Nan of the Hills, D.....

REX

10— 4. The Pipes of Pan, D.....
 10— 8. A Law Unto Herself, D.....
 10—11. Virtue Its Own Reward, D.....
 10—15. Her Life's Story, D.....
 10—18. Kid Regan's Hands, D.....
 10—22. Olaf Erickson—Boss, D.....
 10—25. The Little Blond Lady, D.....
 10—29. White Roses, D.....
 11— 1. The Vagabond, D.....
 11— 5. Let Us Have Peace, C.....
 11— 8. The Link That Binds, D.....

STERLING

10—22. Secret Service Snitz, C.....
 10—26. Snoope's Day Out, C.....
 10—29. A Race for a Bride, C.....
 11— 2. The Wall Between, C.....
 11— 5. Dot's Chaperon, C.....

UNIVERSAL IKE

10— 6. The Neglected Wife.....
 10—13. Mary Green's Husband, and Educational, C.....
 10—13. Mary Green's Husband, and The Monkey Cabaret, C., split reel..

VICTOR

10—16. The Funny Mr. Dingle, C.....
 10—19. Rice Industry in the U. S., E.....
 10—23. The Bride of Marble Head, D.....
 10—26. Terrence O'Rourke No. 1, D.....
 10—30. The Witch Girl, Mary Fuller, D.....
 11— 2. Mary Fuller in "His Big Chance," D.....
 11— 6. Tale of a Lonesome Dog, C.....

MUTUAL FILM PROGRAM

AMERICAN

10—19. In the Daylight, D.....
 10—21. In the Open, D.....
 10—23. The Final Impulse, D.....
 10—26. Sir Galahad of Twilight, D.....
 10—28. Sweet and Low, D.....
 11— 2. The Ruin of Manley, D.....
 11— 4. When the Road Parts, D.....
 11— 9. Red Bird Wins, D.....

BEAUTY

10—13. Winsome Winnie, C.....
 10—20. Dad and the Girls, C.....
 10—27. A Rude Awakening, C.....
 11— 3. The Tightwad, D.....
 11—10. Motherhood, D.....

BRONCHO

10—28. The Golden Goose.....
 11— 4. The Desperado.....
 11—11. Destin's Night.....
 11—18. Shorty Falls Into a Title, C.....

DOMINO

10—22. The Power of the Angelus.....
 10—29. Eric the Red's Wooing.....
 11— 5. In Old Italy.....
 11—12. The Friend.....
 11—19. Nipped.....
 11—26. The Mills of the Gods.....
 12— 3. The Vigil.....

KAY-BEE

10— 9. The Sheriff of Muscatine.....
 10—16. The Word of His People.....
 10—23. The Spark Eternal.....
 10—30. The Worth of a Life.....
 11— 6. The Game of Life.....
 11—13. In the Clutches of the Gangsters.....

KEYSTONE

9— 3. The Baggage Smasher.....
 9— 5. A Brand New Hero.....
 9— 7. The Rounders.....
 9—10. Mabel's Latest Frank.....
 9—12. Mabel's Blunder, C.....
 9—14. All at Sea, C.....
 9—17. Bombs and Bangs, C.....
 9—19. Lover's Luck, C.....
 9—21. He Loved the Ladies, C.....
 9—24. The New Janitor, C.....
 9—28. Hard Cider, C.....
 10— 1. Killing Horace, C.....
 10— 3. Fatty Again, C.....
 10— 5. Their Ups and Downs, C.....
 10— 8. Hello Mabel, C.....
 10—10. Those Love Pangs, C.....
 10—12. Anglers, C.....
 10—15. High Spots on Broadway, C.....
 10—19. Dash, Love and Splash, and Santa Catalina Islands, split reel.....
 10—22. Love Siege, C.....
 10—24. Stout Heart but Weak Knees, C.....
 10—26. Shot in the Excitement, C.....
 10—26. Dough and Dynamite, C.....

KOMIC

9—27. Bill Manages a Prize-Fighter (No. 7)
 10— 4. The Million Dollar Bride.....
 10—11. Bill Spoils a Vacation, (No. 8), C.....
 10—18. Dizzy Joe's Career.....
 10—25. Bill Joins the W. W.'s No. 9..
 11— 1. Casey's Vendetta.....

MAJESTIC

9—29. A Mother's Trust.....
 10— 4. Out of the Air.....
 10— 6. The Unpainted Portrait.....
 10—11. The Sands of Fate, D.....
 10—13. The Warning.....
 10—16. Back to the Kitchen.....
 10—18. For Her Father's Sins.....
 10—20. Environment.....
 10—25. Paid with Interest.....
 10—27. A Mother's Influence.....
 11— 1. Paid with Interest.....
 11— 3. False Pride.....
 11— 8. The Tear That Burned.....

MUTUAL WEEKLY

9—10. No. 89.....
 10—17. No. 90.....
 10—24. No. 91.....
 11— 1. No. 92.....
 11— 8. No. 93.....
 11—15. No. 94.....
 11—22. No. 95.....
 10—27. No. 96.....

PRINCESS

9—18. The Master Hand.....
 9—25. The Balance of Power.....
 10— 2. The Balance of Power.....
 10— 9. The One Who Cared, D.....
 10—16. The Touch of a Little Hand.....
 10—23. The Face at the Window.....
 10—30. The Dead Line.....

RELIANCE

10— 5. Our Mutual Girl, No. 38.....
 10— 7. The Badge of Office.....
 10—10. The Tardy Canon Ball.....
 10—12. Our Mutual Girl (No. 39).....
 10—14. Bad Man Mason.....
 10—17. The Revenue Officer's Deputy.....
 10—19. Our Mutual Girl (40).....
 10—21. Out of the Deputy's Hands.....
 10—24. A Blotted Page.....
 10—26. Our Mutual Girl No. 41.....
 10—30. The Availing Prayer.....
 10—31. The Wrong Prescription.....
 11— 2. Our Mutual Girl No. 42.....
 11— 4. The Miner's Peril.....
 11— 7. A Woman Scorned.....
 11— 9. Our Mutual Girl No. 43.....
 11—14. The Floating Call.....

ROYAL

10—17. The Black Hand.....
 10—24. Harold's Toupee.....
 10—31. Phil's Vacation.....
 11— 7. Max's Money.....
 11—14. A Fortune in Pants.....
 11—21. Love Finds a Way.....

THANHOUSER

9—20. The Mettle of a Man.....
 9—22. The Varsity Race.....
 9—27. The Harvest of Regrets.....
 9—29. The Trail of the Love Lorn.....
 10— 4. A Dog's Love.....
 10— 6. The Cripple.....
 10— 9. The Benevolence of Conductor 786.....
 10—11. The Rescue.....
 10—13. The Diamond of Disaster.....
 10—18. Left in the Train.....
 10—20. Old Jackson's Girl.....
 10—25. Mr. Cinderella.....
 10—27. A Madonna of the Poor.....
 11— 1. Shep's Race with Death.....
 11— 3. The Turning of the Road.....
 11— 8. Keeping a Husband.....
 11—10. The Terror of Anger.....
 11—13. The Chasm.....
 11—15. The Man with the Hoe.....

LUBIN

THE PRODUCER OF MASTERPIECES

EVERY EXHIBITOR SHOULD BOOK THESE BEAUTIFUL PICTURES

(Through the General Film Special Service)

WILLIAM ELLIOTT, Late Star of "Madame X" Company

"THE FORTUNE HUNTER"

6 Reel Comedy By Winchell Smith Produced by Barry O'Neil

"MARAH, THE PYTHONESS"

3 Reel Drama By Clay M. Greene Prod. by Joseph W. Smiley

"THE WEIGHT OF A CROWN"

3 Reel Drama By M. B. Hauey Produced by Harry Myers

READY FOR EARLY RELEASE

By Arrangement with Fred Mace

EVELYN NESBIT THAW

and her son, RUSSELL WILLIAM THAW, in

"THREADS OF DESTINY"

5 Reel Drama By Wm. H. Clifford Prod. by Joseph W. Smiley

EDWIN ARDEN

5 Reel Drama "EAGLE'S NEST" Produced by Edwin Arden Romaine Fielding

RAYMOND HITCHCOCK

In a 5 Reel Comedy Drama by Lawrence McCloskey Produced by George W. Terwilliger

"STONEWALL JACKSON'S WAY"

3 Reel Drama By Emmett Campbell Hall Prod. by Edgar Jones

ROSE COGLAN

And ETHEL CLAYTON in

"THE SPORTING DUCHESS"

6 Reel Comedy Drama By Cecil Raleigh Prod. by Barry O'Neil

SIX REGULAR RELEASES EACH WEEK



"THE BELOVED ADVENTURER" Seventh of Series, "The Holdup" { Drama	Monday,	October 26th
"LOVE AND TITLE" { Split Reel Comedies.....	Tuesday,	October 27th
"SHE MARRIED FOR LOVE" { Split Reel Comedies.....	Tuesday,	October 27th
"THE MOUNTAIN LAW"—Two Reel Drama.....	Wednesday,	October 28th
"THE WOLF'S DAUGHTER"—Two Reel Drama.....	Thursday,	October 29th
"THUMB PRINTS AND DIAMONDS"—Drama.....	Friday,	October 30th
"THE SOUBRETTE AND THE SIMP" { Split Reel Comedies ..	Saturday,	October 31st
"AN INTERRUPTED NAP"		



SPECIAL ONE, THREE AND SIX SHEET POSTERS.

Lubin Manufacturing Company, Philadelphia, Pa.

Chicago Office: 154 West Lake Street

"Flying A" and American

"Beauty" Feature Films

"THE RUIN OF MANLEY"

Under Direction of Thos. Ricketts. A Two Part Psychological Drama. Featuring ED. COXEN and WINNIFRED GREENWOOD. Release Monday, Nov. 2nd, 1914

AMERICAN BEAUTY FILMS

"THE TIGHTWAD"

A Light Comedy With Human Interest. Release Tuesday, Nov. 3rd, 1914

"WHEN THE ROAD PARTS"

A Psychological Drama by an All Star Cast. Release Wednesday, Nov. 4, 1914



Distributed exclusively through the United States and Canada by the Mutual Film Corporation.

AMERICAN FILM MANUFACTURING CO.

CHICAGO

RELEASE DATES FOR READY REFERENCE—Continued

FEATURE RELEASES

ALCO FILM CORPORATION

ALL STAR

- 10—5. The Nightingale, D.....5 parts
- 10—19. The Shore Acres.....

CALIFORNIA MOTION PICTURE CORP.

- 11—2. Salomy Jane5 parts

FAVORITE PLAYERS

- 10—19. The Key to Yesterday, D.....4 parts

POPULAR PLAYS AND PLAYERS

- 10—12. The Ragged Earl, D.....
- 10—26. Michael Strogoff, D.....5 parts

ALLIANCE FILM CORPORATION

EXCELSIOR FEATURE FILM CO.

- 10—19. The Path Forbidden5 parts

FAVORITE PLAYERS

- 10—12. The Key to Yesterday, D.....5 parts

PROGRESSIVE MOTION PICTURE CO.

- 11—2. McVeagh of the South Seas, D.5 parts

SELECT PHOTO-PLAY PRODUCING CO.

- 10—26. At the Old Cross Roads, D....5 parts

APEX

- Sept. Queen of the Counterfeiters, D.4 parts
- Oct. Called to the Front; or Europe at War, D.....3 parts

BOX OFFICE ATTRACTIONS

- 9—21. Will o' the Wisp, D.....4 parts
- 9—28. Fighting the World, D.....5 parts
- 9—28. The Square Triangle, D.....3 parts

COSMOS FEATURE FILM CORPORATION

- 10—15. Lena Rivers, D.....

COSMOFOTOFILM CORPORATION

- Aug. What a Woman Will Do, D.....4 parts
- Sept. England's Menace, D.....3 parts
- Oct. England Expects—, D.....

HEPWORTH-AMERICAN

- Aug. The Girl from the Sky, C.....
- 8—29. The Chimes, D.....3 parts
- The Terror of the Air, D.....2 parts
- Sept. Creatures of Clay, D.....3 parts

HECTOR FILM CORPORATION

- Sept. Born Again, D.....5 parts

GEORGE KLEINE

- Sept. Spartacus, D.....8 parts
- Sept. Vendetta, D.....5 parts
- Sept. The Lion of Venice, D.....6 parts

LIFE PHOTO FILM CORPORATION

- Sept. Captain Swift, D.....5 parts
- Oct. The Ordeal, D.....5 parts

ECLECTIC FILM COMPANY

- Max Has the Boxing Fever, C... 560
- Picturesque Lake Dahl, British India, Scenic 400
- In Soak, C.....
- A Prince of India, D.....
- Pathé Daily News No. 64-1914, Top. Second Door Left, C.....
- Pathé Daily News No. 65, Top... Perils of Pauline, No. 14, D.....
- Colonel Heeza Liar in the Wilderness, C..... 700
- Strange Animals, E..... 300
- Pathé Daily News No. 62-1914, Top. The Colonel's Wife, D.....
- Pathé Daily News No. 63-1914, Top. War Stricken Louvain, Topical....

PARAMOUNT PICTURES

BOSWORTH

- 10—1. Pursuit of the Phantom.....5 parts
- 10—19. Hypocrites!4 parts
- 11—23. Chechako4 parts

FAMOUS PLAYERS

- 11—9. Man from Mexico.....5 parts
- 11—30. Mrs. Black Is Back.....
- 12—21. Step Sisters, D.....5 parts
- 12—28. The Crucible, D.....5 parts
- 12—31. The Million, D.....4 parts

JESSE LASKY COMPANY

- 11—16. The Rose of the Rancho.....5 parts
- 11—26. The Man from Home.....5 parts
- 12—7. Ghostbreakers, D.....5 parts

LASKY-LIEBLER

- 12—24. Cameo Kirby, D.....5 parts

SMALLEYS

- 12—17. False Colors, D.....5 parts

PLAYGOERS FILM COMPANY

- Oct. The Great Diamond Robbery, D..6 parts

PICTURE PLAYHOUSE FILM COMPANY, INC.

- 8—10. The Oath of a Viking.....3000
- 8—19. The Next in Command.....4000

- 8—26. The Film Detective.....4000
- 9—5. The Mystery of the Poison Pool, D.....5 parts
- 9—10. Desperado of Panama, D.....3 parts
- 9—17. Lure of the Yukon, D.....3 parts

RENOWNED PLAYERS

- Sept. A Great Mistake, D.....5 parts

SAWYER, INCORPORATED

- Sept. Tyranny of the Mad Czar, D.....4 parts
- Sept. Doc, D.....4 parts
- Oct. Thirty Minutes in Melodrama, C..2 parts
- Oct. The Factory Magdalen, D.....4 parts
- Oct. The Volunteer Parson, D.....4 parts
- Oct. The Detective Queen, D.....4 parts

WARNER'S FEATURES

- Sept. When We Were Young, D.....
- Sept. The Arrow's Tongue, D.....
- Sept. Alone in New York, D.....5 parts
- Sept. The Price of Crime, D.....3 parts
- Oct. Hunted Down, D.....
- Oct. In the Duke's Power, D.....
- Oct. Bess of the Blazing Sea, D.....
- Oct. The Adventures of Kitty Cobb, D.

WORLD FILM CORPORATION

- 9—14. Protea II, D.....5 parts
- 9—21. The Dollar Mark, D.....5 parts
- 9—28. Mother, D.....4 parts
- The Man in the Cellar, D.....

E. & W. TRANSFILM BUREAU

- Oct. Modern Warfare, D.....6 parts

ANIMATED SONGS

Imperial Motion Picture Co., New York
Latest Releases:

- A Fool There Was.
- Take Me Back to Frisco Town.
- Shadows.
- Father Came Home with the Milkman in the Morning.
- Dear Old Girl.
- What a Wonderful Love That Would Be.
- When I Dream of Killarney.
- Down in Our Old Country Town.
- In the Valley of the Moon.
- Let's Go Back to Sweetheart Days.
- Just a Black Sheep That Strayed from the Fold.
- Let Us Kiss and Make Up Again.
- There's a Lonesome Little Girl in a Lonesome Little Town.
- She Was My Dad's First Sweetheart.
- Down Where the Old Road Turns.
- Push It Along.
- She's Just a Bird in a Gilded Cage.

"SAVING THE COLORS"

(Cosmofotofilm—Three Reels)

REVIEWED BY CLIFFORD H. PANGBURN

THIS is another of the crop of war pictures. Whatever business may be crippled in England by the war, a number of films seems to have been made since hostilities started which depend on the war for their ideas.

"Saving the Colors" is an example. The primary object of the picture seems to be to impress upon the English public the importance of enlisting and the cowardice of the men who do not respond to their country's call. By making use of a number of scenes evidently made for earlier battle pictures the atmosphere of actual conflict is obtained.

The picture was made by the Regent company, under the direction of C. H. Weston, and the leading part is played by Jane Gail.

A wealthy young Englishman is thrown from his horse

and badly hurt. A nurse, on her way to her home for a vacation, passes by and takes the injured man home.

She aids her mother in caring for him, and before he leaves he has fallen in love with her. After her return to the London hospital he continues to see her, and before long they are married.

The young husband is a well-meaning fellow, but has a lot of worthless friends, who lead him into foolish, not to say evil, society pastimes. His young wife, unused to their ways, quarrels with them, thus getting into her husband's bad graces. When she learns that he is flirting with another woman she goes to the war as a nurse.

The husband regards her act as very silly and also laughs at his valet for enlisting. When his friends jeer at his wife he is aroused, and, seeing his own cowardice, enlists. In a battle he saves the flag at enormous risk to himself and is badly wounded. He finds his wife among the nurses who care for him.

MABEL TALIAFERRO SIGNS WITH ROLFE PHOTO

Mabel Taliaferro is the latest recruit to the screen world. Contracts have been signed between Miss Taliaferro and B. A. Rolfe Photo Plays, Inc., whereby Miss Taliaferro will be seen in an early release of the Alco program.

The first picturization in which Miss Taliaferro will appear will be "The Three of Us," originally presented as a legitimate offering at the Madison Square theatre in the days of its latter prosperity. It is a work in the earlier style of Rachel Crothers and had a run in New York of more than two years. B. A. Rolfe Photo Plays, Inc., expect to present Miss Taliaferro in other photo plays.

SILBERMAN REPRESENTS PHOTO DRAMA IN WISCONSIN

The Photo Drama Company of New York City makes the announcement that one Shaw has been using the name of A. E. Siegel, the Cleveland representative of the company, without authority, on heralds describing "After the Ball," produced by the Photo Drama Company.

The Photo Drama Company's representative in Wisconsin is Mr. Silberman, located at 401 Manhattan Building, Milwaukee, Wis., and the Illinois rights to "After the Ball" have been contracted for by the Photo Play Production Company, of Chicago.

Simon Calvin, manager of the New Joy Theatre, Pana, Ill., has just opened for business. The new house is modern and up to date, and seats three hundred people. Mr. Calvin expects to show only the best pictures.

3,500 AT PRIVATE EXHIBITION OF SECOND OZ PICTURE

The Oz Film Manufacturing Company recently gave a private exhibition of "His Majesty, the Scarecrow of Oz," in the auditorium of the Los Angeles Athletic Club.

Over thirty-five hundred people attended and enjoyed every foot of the photo extravaganza.

The general opinion seems to be that in this second picture, the Oz Film Manufacturing Company has turned out a picture far superior to the "Patchwork Girl of Oz," which is at present playing with such tremendous success throughout the country. Both pictures are capable of drawing immense crowds.

CLASSIFIED

FOR SALE

ARC LAMPS—Two flaming arc lamps, 110 volts A. C. current burn in series. They are good as new, only used short time, cost \$142.60; will sell for \$60.00. Send \$10.00 cash deposit and shipment will be made C. O. D. subject to examination. AMERICAN SLIDE CO., 165½ N. High St., Columbus, O.

PROJECTION MACHINES—Second hand moving picture machines cheap. We have a Powers No. 5 Complete, without rheostat, \$50.00. Standard No. 2, \$50.00. Edison Exhibition model, \$40.00. Edison Model B. Steel head, \$65.00. Terms \$10.00 cash with order, balance C. O. D. subject to examination. These machines have been completely overhauled in our own repair department and all bad parts replaced and ready to show a picture. Lenses to suit your throw. AMERICAN SLIDE CO., 165½ N. High St., Columbus, O.

FURNITURE & FURNISHINGS
On RENTAL
We equip your settings complete in accordance with your scenario.
WILLIAM BIRNS
103-105 West 37th St.
Phone: Greeley 6255.

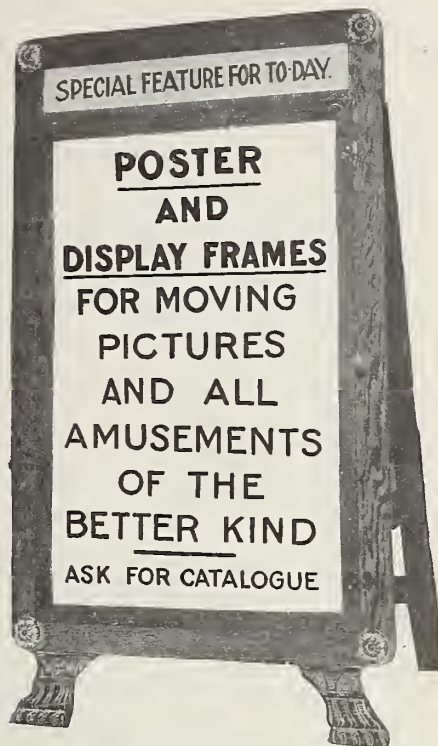

MENGER & RING

302 W. 42nd Street
New York

TELEPHONE

BRYANT 6621

YOU ARE TO BLAME

if you don't get "Motion Picture News" every week. Use your pencil and fill in the subscription blank NOW.

Selznick Makes Another Capture for the World Film Corporation

Frank L. Dyer (Former President, General Film Company), J. Parker Read, Jr. (Producer of the photo-plays, "The Garden of Allah" and "Victory"), J. Searle Dawley (the man who made the Famous Players famous), Director General.

HAVE JOINED FORCES IN ORGANIZING THE

DYREDA ART FILM CORPORATION

To produce the most artistic motion pictures yet undertaken. The culminating step in their making that work possible has come in their securing the

WORLD FILM CORPORATION

to become their exclusive distributors, because the World Film Corporation is the only high grade feature film distributors who can properly market the Dyreda's artistic product. The first feature to be released through the World Film Corporation from the Dyreda's Studios is

LAURA SAWYER in "ONE OF MILLIONS"

The most impressive, touching, indictment of the evils of war ever conceived. Produced by the poet of the screen, J. SEARLE DAWLEY, who made "The Charge of the Light Brigade," and other film sensations. Release date, Nov. 16. The next Dyreda release will be Laura Sawyer and Robert Broderick in

"In The Name of The Prince of Peace." Release date on this feature is to be announced later.

For bookings on these and all future Dyreda features communicate at once with the nearest exchange of the

WORLD FILM CORPORATION, 130 West 46th Street, New York

26 branches throughout the United States and Canada.

12 more branches now being opened.

NEW DEPARTMENT FOR "NEPTUNE'S DAUGHTER"

The ever increasing demand from leading theatres of the country who play the most prominent Broadway successes for Annette Kellermann in the seven-part photo play masterpiece, "Neptune's Daughter," has encouraged the Universal Film Manufacturing Company to establish a special booking department for the purpose of handling this increased volume of business.

Past arrangements with the United Booking Offices or any other agencies have been terminated. "Neptune's Daughter" is reaping its greatest whirlwind of success from return bookings, thereby demonstrating unquestionably that this is one picture which really pleases the better class of theatre-goers.

Nine companies are now on tour and a tenth opens at the Metropolitan Opera House, St. Paul, on October 25. All inquiries for this attraction from unsold territory should be made direct to the Universal Booking Offices, 1600 Broadway, New York City.

OFF ON A QUIET VACATION

Ruth Ann Baldwin, one of the Universal company's scenario writers, has left the West Coast studios on a vacation, her destination unknown.

Trades Association Meeting a Success

Consensus of Opinion Among Those at Hotel Wellington Gathering Favors Manufacturers' Exposition—Organization Committee Named

A WELL-ATTENDED meeting of the Motion Picture Trades' Association was held the evening of October 20 at the Hotel Wellington, New York City.

Frank J. Rembusch presided. Opening speeches, explaining the movement, were made by J. W. Farnham, of the All Star Feature Corporation, and Carl Anderson, of the Jesse L. Lasky Feature Play Company. Tom Moore explained the manner in which the expositions of the electrical and automobile trades are held by the manufacturers in these other industries.

An open discussion participated in by practically all of the manufacturers present followed. The consensus of opinion was decidedly in favor of having the next exposition of the motion picture industry conducted by the manufacturers. A great many letters from all over the country showing extreme interest in the movement were read by President Rembusch.

An organization committee was appointed and the meeting adjourned for four weeks.

Among those present were: William

Wright, Kalem Company; Eugene F. Licone, Rudolph Wurlitzer Company; Arthur James, Mutual Film Company; R. C. Decker, Robbins & Myers Company; Adolph Zukor, Famous Players Film Company; Jacob William Binder, National Board of Censorship; Samuel Goldfish, Jesse L. Lasky Feature Play Company; B. A. Proctor, Kinoikon Apparatus Corporation; Tom Moore, Alco Film Company; Jesse Lasky, Jesse L. Lasky Feature Play Company; Carl Anderson, Jesse L. Lasky Feature Play Company, Wm. A. Johnston, MOTION PICTURE NEWS.

Wm. C. Smith, Nicholas Power Company; J. F. Alexander, Wagner Electric Manufacturing Company; J. F. Coufal, Novelty Slide Company; C. E. Davidson, Strauss & Company; Wm. W. Hodgkinson, Paramount Pictures Corporation; Ernst Glantzberg, Typhoon Fan Company; J. F. Stuart, Robbins & Myers Company; Harry Scott, Sterling Camera & Film Company; A. E. Kirshmer, Slocum Avram & Slocum; J. L. Hoff, *Moving Picture World*.

C. R. Baird, Baird Motion Picture Machine Company; Richard Pollard, Bausch & Lomb Optical Company; Gustave Schroeder, Schroeder Art Flower Manufacturing Company; Merritt Crawford, Mutual Film Company; Joe Farnham, All Star Feature Corporation; F. J. Rembusch, Mirror Screen Company; A. H. Byrd, Wyanoak Publishing Company; S. M. Spedon, Vitagraph Company.

STATEMENT OF THE OWNERSHIP, MANAGEMENT, CIRCULATION, ETC., required by the Act of August 24, 1912, of MOTION PICTURE NEWS, published weekly at New York, N. Y., for October 1, 1914.

Editor, William A. Johnston, 220 West Forty-second street, New York; managing editor, Lesley Mason, 220 West Forty-second street, New York; business manager, H. Ashton Wyckoff, 220 West Forty-second street, New York; publisher, Exhibitors' Times, Inc., 220 West Forty-second street, New York.

Owners (if a corporation, give its name and the names and addresses of stockholders holding 1 per cent. or more of total amount of stock. If not a corporation, give names and addresses of individual owners.): Exhibitors' Times, Inc., 220 West Forty-second street, New York; William A. Johnston, 220 West Forty-second street, New York; E. Kendall Gillett, 220 West Forty-second street, New York; H. Ashton Wyckoff, 220 West Forty-second street, New York; Henry F. Sewall, 220 West Forty-second street, New York; P. S. Alden, 220 West Forty-second street, New York; Wentworth Tucker, 220 West Forty-second street, New York; Carl Tucker, 220 West Forty-second street, New York.

Known bondholders, mortgagees, and other security holders holding 1 per cent. or more of total amount of bonds, mortgages, or other securities (if there are none, so state.): None.

Average number of copies of each issue of this publication sold or distributed, through the mails or otherwise, to paid subscribers during the six months preceding the date shown above. (This information is required from daily newspapers only.) Weekly magazine.

(Signed) H. ASHTON WYCKOFF,
Business Manager.

Sworn to and subscribed before me this 5th day of October, 1914.

(Seal.) ADA M. RILEY.

Certificate filed in New York County, No. 3323.

Certificate filed in Register's Office, New York County, No. 6177.

(My commission expires March, 1916.)

Old Favorites on Box Office Program

New Releases Include "The Walls of Jericho," "The Thief," a Frohman Success, Featuring Dorothy Donnelly and "The Idler"

WINFIELD SHEEHAN, general manager of the Box Office Attractions Company, announces big plans for his company.

Twenty-nine exchanges have been established and are now active in the leading cities of the United States so that every territory can now be served overnight, excepting only the Rocky Mountain section. Fifteen of these exchanges are more properly district offices, elaborately furnished and fitted with projection rooms and complete facilities for the showing of pictures.

The exchange managers in each instance are picked men who have already proven their ability and are well known in the exchange field. The exchanges are located in the following cities: Boston, Syracuse, Philadelphia, Pittsburgh, Cleveland, Chicago, Minneapolis, St. Louis, Kansas City, Dallas, Denver, San Francisco, Seattle, Los Angeles, Portland, Butte, Salt Lake City, Des Moines, Omaha, New Orleans, Atlanta, Charlotte, Cincinnati, Indianapolis, Detroit, Baltimore and Buffalo.

The new Box Office program will include three three-reel features produced by the Balboa, the White Star and Nemo; three single-reel comedies known as the "Joy Comedies," together with such productions as "The Walls of Jericho," featuring Edmund Breese; Frohman's "The Thief," by Henri Bernstein, featuring Dorothy Donnelly; "The Children of the Ghetto," by Israel Zangwill;

"The Girl I Left Behind Me," which was written by David Belasco and produced by Charles Frohman, featuring Robert Edeson; "A Fool There Was," "The Idler," by Haddon Chambers, featuring Charles Richmond; Frohman's production of "Samson"; "Life's Shop Window," from the well-known book by Victoria Cross, featuring Claire Whitney and Stewart Holmes.

Recent additions to the staff of the Box Office Attractions Company include Albert Doris, formerly with the Frohman and Savage companies, and F. W. Mead, formerly in charge of the film department of the United Booking Offices for New England.

Mr. Mead will have charge of the Boston office for the Box Office Attractions Company. H. Z. Levine, who has charge of the advertising and publicity, has installed an art department.

JANE COWL WITH ALL STAR

The All Star Feature Corporation has signed a contract that ensures to that company the services of Jane Cowl.

Miss Cowl is to appear in the picturization of Eugene Walter's play "The Easiest Way," which will be released by the Alco Film Corporation. During the past year Miss Cowl has refused many offers from prominent moving picture concerns to appear on the film. Jane Cowl during her first season on the stage understudied the part of Laura Murdoch.

ANNETTE KELLERMAN

"THE PERFECT WOMAN," AND COMPANY
OF ONE THOUSAND PLAYERS
IN

NEPTUNE'S DAUGHTER

THE SEVEN PART AMERICAN MASTERWORK.
DIRECT FROM RECORD BREAKING RUNS IN
THE COUNTRY'S FOREMOST METROPOLITAN
THEATERS. THE MOST UNIQUE, FANTASTIC,
AND ALL ABSORBING MOTOGRAPHIC
SPECTACLE EVER EVOLVED.

**NOW OPEN FOR BOOKINGS
IN ALL FIRST CLASS THEATERS
RENT OR SHARING TERMS**

IF YOU HAVE A THEATER AND WANT TO MAKE
BIG MONEY, BOOK THIS FEATURE AT ONCE.
THE FOLLOWING TERRITORY HAS BEEN
SOLD—FOR BOOKINGS APPLY DIRECT TO
NEW ENGLAND STATES, UNIVERSAL FILM EXCHANGE, 1100
BOYLSTON ST., BOSTON. N. Y. STATE, (EXCLUSIVE OF GREATER
N. Y.), VICTOR FILM SERVICE, BUFFALO, N. Y. CALIFORNIA,
ARIZONA & NEVADA, NAT. A. MANGER, CARE OF CALIFORNIA
FILM EXCHANGE, LOS-ANGELES, CAL. VIRGINIA, WEST
VIRGINIA, NO. CAROLINA, KENTUCKY, INDIANA & KANSAS,
R. R. ROBERTS, LONGACRE BLDG, N. Y. CITY. SO. CAROLINA,
GEORGIA, FLORIDA, TEXAS, MISSISSIPPI, TENNESSEE, ALABAMA
& ARKANSAS, CONSOLIDATED FILM & SUPPLY CO., ATLANTA,
GEO. MICHIGAN, CHARLES L. HERTXMAN, DETROIT, MICH.
OHIO, McMAHON, JACKSON & EVANS, CINCINNATI, O. ILLINOIS,
ALF. HAMBURGER, ZIGFELD THEATER, CHIC. WISCONSIN,
NORMAN DIXON, UNIVERSAL FILM EXCH., MILWAUKEE, WIS.



FOR ALL OTHER TERRITORY WIRE, PHONE OR WRITE TO

UNIVERSAL FILM MANUFACTURING CO.
1600 BROADWAY

NEW YORK CITY



ALCO

A NEW SYNONYM
 FOR QUALITY 

CONCENTRATED COMPETENCE

is a two word summary of the Alco Film Product which is the work of the bright minds of filmdom gathered in the several studios of the

ALL STAR FEATURE CORPORATION—CALIFORNIA M. P. CORPORATION—POPULAR PLAYS AND PLAYERS—TIFFANY M. P. CORP.—B. A. ROLFE PHOTO PLAY CO.

COMING

SALOMY JANE—Nov. 2

By Arrangement with the Liebler Co.

Produced by the

CALIFORNIA M. P. CORPORATION

RIP VAN WINKLE—Nov. 9

WITH THOMAS JEFFERSON

Produced by the

B. A. ROLFE PHOTOPLAY CO.

OFFICES OF THE ALCO FILM SERVICE

NEW YORK, 218 West 42d Street.
 For State of New York.

CHICAGO, 512 Mallery Building, 5 So. Wabash
 Avenue.
 For Illinois, Indiana.

SAN FRANCISCO, 234 Eddy Street.
 Cor California, Nevada, Arizona.

BOSTON, 162 Tremont Street.
 For Maine, New Hampshire, Vermont, Rhode Island,
 Massachusetts, Connecticut.

PHILADELPHIA, 1331 Vine Street.
 For Southern New Jersey, Eastern Pennsylvania.

PITTSBURGH, 212 Fourth Avenue.
 For Western Pennsylvania, Ohio, Kentucky, West
 Virginia.

BALTIMORE, 327 St. Paul Street.
 For Delaware, Maryland, District of Columbia,
 Virginia.

ST LOUIS, New Grand Central Theatre, Grand and
 Lucas Avenues.

For Missouri, Kansas, Iowa, Nebraska,
 NEW JERSEY, 71 W. 23d Street, New York.
 For Northern New Jersey.

MINNEAPOLIS, Temple Court Bldg.
 For Wisconsin, Minnesota, North and South Dakota.

LOS ANGELES, 514 West 8th Street.
 For California, Nevada, Arizona.

DALLAS, 1902 Commerce Street.
 For Texas, Oklahoma, Arkansas.

SEATTLE, 1214 Third Avenue.
 For Washington, Idaho, Montana, Oregon.

SPOKANE, 911 Trent Avenue.
 For Washington, Idaho, Montana, Oregon.

BUTTE, 27 W. Park Street.
 For Washington, Idaho, Montana, Oregon.

PORTLAND, ORE., 710 Northwestern Bank Bldg.
 For Washington, Idaho, Montana, Oregon.

ALCO FILM CORP.
 ALCO BUILDING, 218 W. 42nd ST., NEW YORK

JAMES A. HERNE'S BEAUTIFUL NEW ENGLAND PLAY

SHORE ACRES

PRODUCED IN MOTION
PICTURES BY THE ALL
STAR FILM CORP. AN
ADEQUATE
RENDITION
AND CAST
OF UNUSU-
AL ABILITY

A
BIG
FINE
THING
5 REELS
IN LENGTH

ALCO FILM CORP.

ALCO BUILDING, 218 W. 42nd ST., NEW YORK

Warning to Exhibitors

KEYSTONE films have become so popular that unscrupulous dealers are at work again selling dupes throughout the country. The only genuine KEYSTONE films are those rented exclusively in the United States and Canada through the Mutual Film Exchanges. This Company will ferret out and prosecute and punish to the extent of the law, those duping KEYSTONE films or exhibiting dupes.

THE KEYSTONE FILM COMPANY A. KESSEL, Jr.
 President
 LONG ACRE BUILDING Broadway and 42nd Street NEW YORK CITY

INVEST SOME MONEY in BRAINS

Put your Advertising Department in my hands and have it pay for itself. You probably regard your advertising Department as an expense. It should be self-supporting. I can make it so.

I have written and can write

Real Live, Selling Advertising

I know Printing, Lithographing and Engraving and can cut the costs of this matter, at the same time raising the quality and efficiency.

I want the position of publicity manager for a live—real live—manufacturer or distributing company. If you want to invest a moderate sum each week in Real Advertising Brains from which there will be a good return, write to make a personal appointment.

ADDRESS

H. J. S.
 Care of MOTION PICTURE NEWS

"THE CRIMINAL CODE"

(Balboa-Box Office—Four Reels)

REVIEWED BY CLIFFORD H. PANGBURN

A MELODRAMA of unusual excellence. The plot possesses much more novelty than is often found in this type of picture, beside avoiding many of the situations which are so often present in melodrama.

Besides the plot, the general good sense which has been shown in producing the picture adds much to its attractiveness. Anyone who will study a film of this sort can see at a glance that many of the flagrant errors which frequently mar what might be excellent productions can be avoided very simply.

It does not require genius so much as it requires what is commonly called horse sense. In "The Criminal Code" it can be said that there is not a single setting which is not a good representation of whatever is supposed to be represented.

This, it need hardly be stated, partakes almost of the nature of a triumph. Even a large reception and dance at the home of a man of wealth and refinement is well staged amidst surroundings indicative of fairly good taste. The exteriors are as well handled. Full advantage has been taken of the California sunlight and scenery. Among the particularly striking views are those which show the hero fishing in a small stream.

William D. Taylor and Neva Gerben in the leading roles do acting which is in keeping with the other good points of the picture, and the general result is a happy one.

The story concerns a girl who left an orphanage on account of harsh treatment. She is adopted and educated by a man who makes a business of stealing valuable jewelry while passing off as a respectable business man.

He does this because he makes use of social events to help him and thinks the girl can assist. She is so frightened at the thought of being turned out into the streets that she aids in robbery, but when it comes to stealing a necklace from one of her old school friends she rebels. For a time it looks bad for her, but eventually she finds love and happiness with a young lawyer.

MASTERPIECE JOINS ALLIANCE PROGRAM

Frank C. Hill and George S. Hupp, of Los Angeles, secretary and treasurer and assistant secretary, respectively, of the Masterpiece Film Company, who have been in New York for several days, left for the California Coast on Tuesday, October 20.

Messrs. Hill and Hupp have arranged for the distribution of their company's productions through the Alliance Films Corporation.

After careful investigation they report the Alliance plan of distribution an excellent one.

The first release of the Masterpiece Film Company, "The Hoosier Schoolmaster," featuring Max Figman and Lolita Robertson, will be followed by other Figman-Robertson features at the rate of at least one production every five weeks. A second company is already at work and other arrangements are being made to increase the output.

Lolita Robertson, in their opinion, will prove the equal in popularity of any screen actress of the day. The company's contract with Max Figman gives them the exclusive use of this popular and able actor for two years.

Rights have been obtained to "The Truth Wagon," in which John Cord starred Mr. Figman to "Jack Chanty" to the Williamson's popular novel "Lord Loveland Discovers America," and to seventeen other books and plays to be announced later. "Masterpiece policy is quality," said Mr. Hill, in summing up the company's plans.

Add to the attractiveness of
YOUR LOBBY DISPLAY.

USE LIFE SIZE PHOTOGRAPHS

Either Character or Straight Photographs from 8 x 10's to 30 x 60's of leads now playing Southern California, made from original negatives.

NOW READY: The Spoilers and The Avenging Conscience.

Coming Releases: The Carpet from Bagdad, The Blood Red Rose, and The Rosary.

Write for 30-day introductory offer.

PHOTOPLAYERS STUDIO

342 South Broadway, Los Angeles, Cal.

IF YOUR COPY

of the "News" does not reach you promptly every week, please advise us.

Manufacturers of the Wonderful
Rembusch Patented Glass MIRROR SCREEN
and all other kinds of
Curtains for Moving Picture Projection

GLASS SCREENS	METALLIZED SCREENS
Mirror Screen	Gold Fibre
Mirror Screen Split	Silvercloth
Glass Transparent Screen for Rear Projection	Mirror Cloth
	Seamless, with stretchers
	White Opaque

Phone Seven-Eleven F. J. REMBUSCH, Pres.

MIRROR SCREEN COMPANY

Incorporated

SHELBYVILLE, INDIANA

Mr. O. P. Sammons of Denison, Texas, bought a "Mirror Screen," and he writes that he cannot take care of the crowds. His picture is simply the talk of the community. A few second-hand screens for sale cheap.
Eastern Representative, Frank Manning, 125 W. 48th St., N. Y. Phone, Bryant 2410.

Mr. Exhibitor:

WHY ?

Why is it a fact that an Exhibitor who has invested many thousands of dollars, in a theatre for the display of Motion Pictures, will very often pay so little attention to the importance of the moving picture Screen? THE PUBLIC do not always come to see your building or its furnishing, but they do come to see the pictures; and good pictures depend on perfect projection.

MIRROROIDE is the best projection surface known, producing the clearest, brightest pictures at less cost for current. It does not crack, peel, or turn black, and is guaranteed for five years against deterioration. It may be washed with soap and water without injury, and it is KING OF ALL PROJECTION SURFACES. Send for our large free samples and prove the truthfulness of the above statement.

Over 8,000 Mirroroide Screens in use.

Yours for greater success,

J. H. GENTER CO., INC., Newburgh, N. Y.

Agencies all General, Mutual and Universal Exchanges and Supply Dealers the world over. At 36 1-9 Cents a Sq. Ft., \$3.25 a Sq. Yard.

SAVE 70% OF MACHINE UP-KEEP BY INSTALLING A LATE MODEL

MOTIOGRAPH

All Motiograph users save in up-keep. There's a reason. It's the special selected material and hardened parts used in the MOTIOGRAPH.

(Don't make a mistake and get a machine with soft parts.)

THE ENTERPRISE OPTICAL MFG. CO., 568 W. Randolph St., CHICAGO, ILLS.

Eastern Office: 21 E. 14th St., New York

Western Office: 833 Market St., San Francisco

CLEARED

Manufacturers

MASTERPIECE FILM MFG. CO., 1111 Van Nuys Bldg., Los Angeles, featuring MAX FIGMAN and LOLITA ROBERTSON

FAVORITE PLAYERS FILM CO., Inc., 110 W. 40th St. N. Y. City, featuring CARLYLE BLACKWELL.

EXCELSIOR FEATURE FILM CO., Inc., 110 W. 40th St., N. Y. City, featuring OCTAVIA HANDWORTH.

SELECT PHOTOPLAY PRODUCING CO. 110 W. 40th St., N. Y., City, featuring original stars in plays.

PROGRESSIVE MOTION PICTURE CO., Times Bldg., N. Y. City, featuring HARRY CAREY.

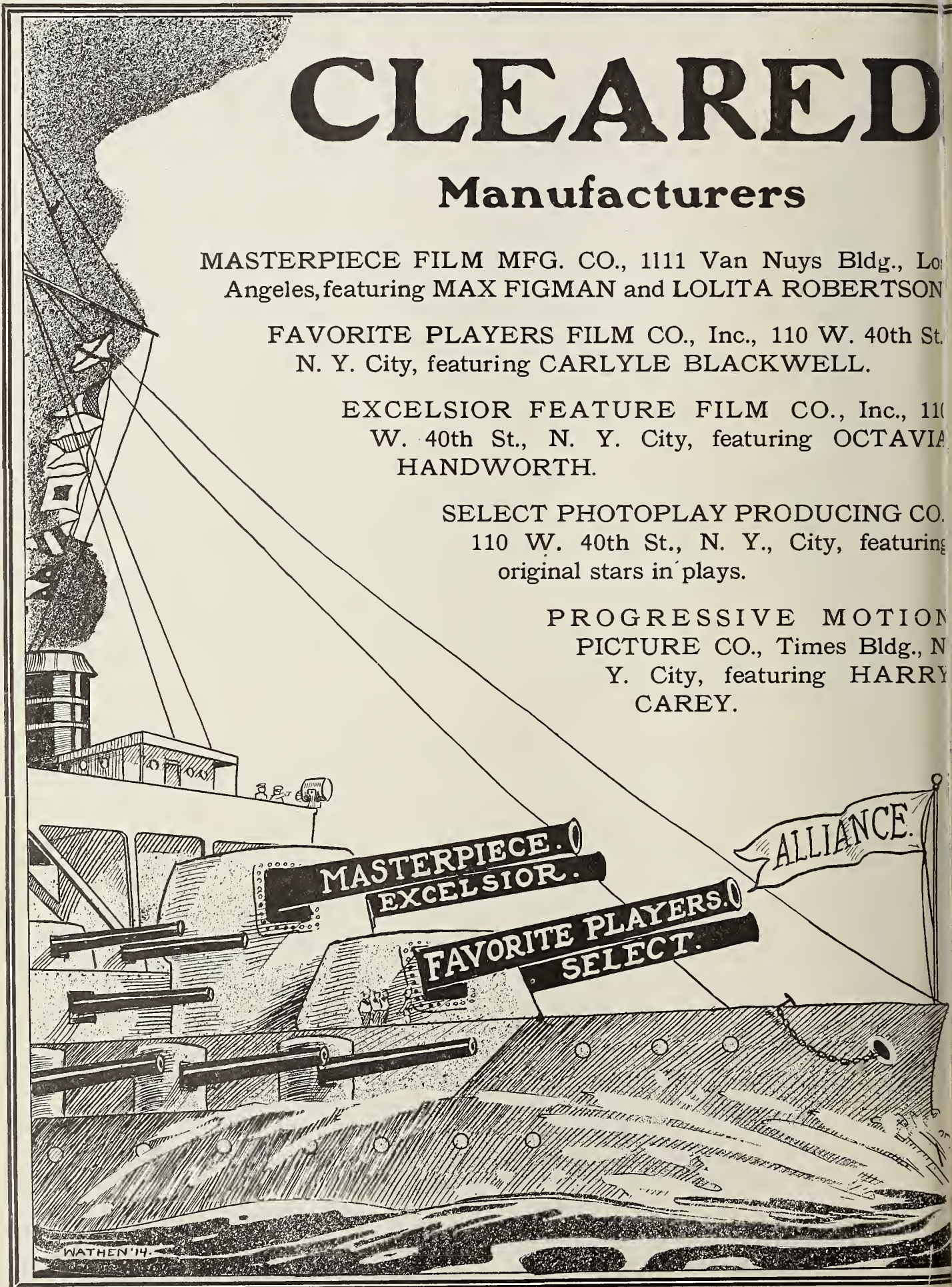

FOR ACTION!

Releases

"The Key to Yesterday"

Released Oct. 12 by Favorite Players Film Co. From book by Chas. Neville Buck, with Carlyle Blackwell in leading role.

"The Path Forbidden"

Released Oct. 19 by Excelsior Feature Film Co. From book by John B. Hymer, with Octavia Handworth playing the dual role of the twin sisters.

"At the Old Cross Roads"

Released Oct. 26 by Select Photoplay Producing Co. Arthur C. Aiston's famous play, with Estha Williams, the original star, in the leading part.

"McVeagh of the South Seas"

Released Nov. 2 by Progressive Motion Picture Co. A story of daring and action, featuring Harry Carey.

"The Hoosier Schoolmaster"

Released Nov. 9 by Masterpiece Film Mfg. Co. Featuring Max Figman and Lolita Robertson in Edward Eggleston's immortal story.

"The Man Who Could Not Lose"

Released Nov. 16 by Favorite Players Film Co. From book by Richard Harding Davis, featuring Carlyle Blackwell.

"When Fate Leads Trump"

Released Nov. 23 by Excelsior Feature Film Co. From book by John B. Hymer, with Octavia Handworth in leading role.

NOTE: The above program is ON FILM and not ON PAPER. All the subjects advertised have actually been produced and are ready for exhibition. Watch for list of subjects completed and in preparation.

Exchanges

ALLIANCE FILM SERVICE, 115 Fourth Ave., Pittsburg, Pa. A. A. Weiland, Mgr. Ohio, Western Pennsylvania and Western Virginia.

ALLIANCE FILM SERVICE, 18 Chapin Block, Buffalo, N. Y. M. F. Tobias, Mgr. New York State.

ALLIANCE FILM SERVICE, 128 West 46th St., New York City. New York City, Connecticut, Massachusetts, Vermont, New Hampshire and Maine.

ALLIANCE FEATURE FILM SERVICE, controlled by Mecca Feature Film Co., 130 W. 46th St., New York City. Northern New Jersey.

ELECTRIC THEATRE SUPPLY CO., Vine and 13th St., Philadelphia, Pa. Southern New Jersey, Eastern Pennsylvania, Maryland, Delaware, District of Columbia.

ALLIANCE FILM SERVICE, 417 Rhodes Bldg., Atlanta, Ga. P. P. Craft, Mgr. Virginia, North Carolina, South Carolina, Georgia, Florida, Alabama, Mississippi, Tennessee and Louisiana.

ALLIANCE FILM SERVICE, 311 Andrews Bldg., Dallas, Tex. P. P. Craft, Mgr. Texas, Arkansas and Oklahoma.

CELEBRATED PLAYERS FILM CO., 64 W. Randolph St., Chicago, Ill. Illinois.

NAT. A. MAGNER CO., Pacific Bldg., San Francisco, Cal. California, Nevada, Arizona.

CO-OPERATIVE SERVICE CO., Indianapolis, Ind. E. H. Brient, Mgr. Indiana, and Kentucky.

NOTE: As this advertisement goes to press we are concluding negotiations with exchanges for the balance of the territory.

ALLIANCE FILMS CORPORATION

126 W. 46th St.

Leavitt Bldg.

N. Y. City

**ALLIANCE
PROGRAM**

**ALLIANCE
PROGRAM**

"The Path Forbidden"

IN FIVE REELS, FEATURING
OCTAVIA HANDWORTH



RELEASED OCTOBER 19

From the book by John B. Hymer. Amazing scenes are shown as Miss Handworth plays the dual role of the twin sisters. Exquisite photography, marvelous trick work and effects and a large cast make this an extraordinary production.

"When Fate Leads Trump"

Released November 23. From the book by John B. Hymer, featuring OCTAVIA HANDWORTH.

EXCELSIOR FEATURE FILM CO., Inc.

HARRY HANDWORTH, President

WM. H. WRIGHT, Treasurer

ARTHUR ROSENBACH, Sales Manager

110 WEST 40TH STREET World's Tower Bldg.

NEW YORK CITY

ALLIANCE PROGRAM "At The Old Cross Roads" **ALLIANCE PROGRAM**

Arthur C. Aiston's famous play, featuring
MISS ESTHA WILLIAMS



RELEASED OCTOBER 26 IN FIVE REELS

Miss Williams, in her original role of Parepa, is supported by Mrs. Stuart Robson, Arthur Morrison, Miss Rae Ford and a large cast.

The production teems with exciting incidents, including a spectacular conflagration, the uprising of the blacks and the ensuing battle at the Old Cross Roads, the sensational court room scene, etc., etc.

Scenario written and produced by Frank L. Dear

SELECT PHOTOPLAY PRODUCING CO.

S. G. LINDEMAN, Treasurer

110 WEST 40TH STREET

NEW YORK CITY

**ALLIANCE
PROGRAM****ALLIANCE
PROGRAM**

"MCVEAGH OF THE SOUTH SEAS"

Featuring HARRY CAREY



RELEASED NOV. 2, IN FIVE REELS

A stupendous production, from the book by H. D. Carey, staged in the south seas when might was right and men knew no law. Abounding in thrilling situations and sensational scenes. Beautiful island and ocean backgrounds.

Progressive Motion Picture Co.

TIMES BUILDING

NEW YORK CITY

ALLIANCE PROGRAM

"THE HOOSIER SCHOOLMASTER"

ALLIANCE PROGRAM

Edward Eggleston's Immortal Book Dramatized in Five Reels, with

Mr. Max Figman

Supported by

Miss Lolita Robertson

A great American Classic, interpreted by National Stars. Released November 9 in the **ALLIANCE PROGRAM**



A Superb Production in Flawless Photography.

Accurately Staged and Costumed in the Quaint Costumes and Settings of the period.



Masterpiece Film Manufacturing Co.

1111 Van Nuys Bldg. Los Angeles, Cal.

**ALLIANCE
PROGRAM****ALLIANCE
PROGRAM**

"THE MAN WHO COULD NOT LOSE"

IN FIVE REELS, FEATURING

Carlyle Blackwell



RELEASED NOVEMBER 16 IN FIVE REELS

An absorbing story of mingled pathos, comedy and sensationalism, from the pen of

RICHARD HARDING DAVIS

showing the adventures of a man who rises from poverty to riches, settles a feud in a unique manner, and wins the girl of his choice. Thrilling scenes at the race track.

FAVORITE PLAYERS FILM CO., Inc.

M. H. BLACKWELL, Treasurer

110 WEST 40TH STREET

Suite 1003

NEW YORK CITY

THE KRITERION PROGRAM

will be distributed from the following cities

New York, Boston, Philadelphia, Baltimore, Pittsburg, Cleveland, Cincinnati, Indianapolis, Chicago, Minneapolis, St. Louis, Kansas City, Atlanta, Dallas, Denver, Seattle, San Francisco, Los Angeles, Winnipeg, Montreal.

MONDAY **TUESDAY** **WEDNESDAY** **THURSDAY** **FRIDAY** **SATURDAY**
 Comedy Special Comedy Special Comedy Special Comedy Special Comedy Special Comedy Special

SUNDAY

SPECIAL—Well Known—STAR

WHAT IS OUR POLICY? "Made in America Photoplays" of a quality that will pleasantly interest the most critical pictureplay lovers.

MR. EXHIBITOR: Enquire in above cities, or better yet, communicate with below mentioned company, and we will supply your wants and furnish you with the desired information.

NOTICE: This space will continue to grow and give out more and valuable weekly information.

MECCA FILM CORPORATION

(Temporary Headquarters)

220 West 42nd St. Our new home is being prepared New York City

OUR NEXT RELEASE

MRS. THOMAS WHIFFEN

The Grand Old Lady of the American Stage

in a five-part photoplay

"HEARTS AND FLOWERS"

A thrilling Drama of Love and Sacrifice. Adapted by and produced under the direction of
JOSEPH A. GOLDEN

State Right Buyers who are looking for exceptional features will secure their territory at once. Do not hesitate. This is a Sure Winner.

Read what the Critics say about our recent release of

BEULAH POYNTER IN HER OWN PLAY **"LENA RIVERS"**

Some Good Territory Still Open

COSMOS FEATURE FILM CORPORATION

126 WEST 46th STREET, NEW YORK



Registered.

EACO FILMS

EACO FILMS

THE STRAND FILM COMPANY

HAVE SECURED THE EXCLUSIVE AMERICAN RIGHTS FOR PRODUCTIONS OF

THE EACO FILMS, Inc.

IN WHICH THE STERLING SCREEN ARTIST

MR. EDWIN AUGUST

WILL BE STARRED

First Release Now Ready

"THE MILLIONAIRE DETECTIVE"

A STIRRING THREE REEL MELODRAMA IN WHICH THROUGH A CLEVER RUSE TWO SOCIETY DETECTIVES EXPOSE A GANG OF COUNTERFEITERS AND THEREBY REVEAL A BAFFLING MURDER MYSTERY.



MR. EDWIN AUGUST
("The Man on the Film")

Second Release in Preparation

"A STRANGE ADVENTURE" A STRONG THEME

EDWIN AUGUST

Late Universal Star

Means Money to Live
Aggressive Exhibitors

THE MERITS OF EACO FILMS ARE UNUSUAL LIGHT EFFECTS—ELABORATE INTERIORS—STRONG, ORIGINAL STORIES—PROPER CASTING AND EXCELLENT PLAYERS

EACO FILMS

STRAND FILM COMPANY

145 W. 45th Street
New York City

EACO FILMS



"Mary Jane's Burglar"



"The Vanishing Cinderella"



"It Might Have Been Worse"

MAUDE FEALY

will appear exclusively in productions staged by the
HOLLAND FILM MFG. CO.

It is unnecessary for us to feature Miss Fealy—she is known and loved all over the world. Supported by a company of well-known artists second to none in the profession—the answer is simple—packed houses and delighted audiences.

EARLY RELEASES

ONE-REEL FEATURES

TWO-REEL FEATURE

"Mary Jane's Burglar"
"The Vanishing Cinderella"
"It Might Have Been Worse"
"The Double-Cross"
"Norah Declares War"

"The Girl from Tim's Place"
(adapted from the novel by the
well-known author,
CHARLES CLARK MUNN)

Send for complete information about these and future releases.

SPECIAL POSTERS

HOLLAND FILM MANUFACTURING COMPANY

105 Lawrence Avenue

Dept. C

DORCHESTER, MASS.

YOU WANT
GOOD
POSTERS

WE WILL
SUPPLY
THEM

THE POSTER QUESTION IS YOUR MOST VITAL ONE. You cannot expect that the public will guess what pictures you are showing in your theatre. More than that, **YOU CANNOT EXPECT TO BRING THE PUBLIC INTO YOUR THEATRE BY DISPLAYING A QUANTITY OF WORTHLESS TRASH.**

THE SOLUTION!

The MORGAN POSTERS are the **only** solution. These POSTERS are manufactured from an artistic and attention-gripping standpoint. **THEY WILL PULL THE PEOPLE FROM THE STREET AND INTO YOUR THEATRE.**

THREE-SHEETS FOR ONE-REEL PICTURES!!!

That is merely one instance of MORGAN PROGRESSIVENESS. It is an **innovation**, the value of which is unquestioned. **YOU CAN GET 3-SHEETS FOR 1-REEL UNIVERSAL PICTURES AT YOUR UNIVERSAL EXCHANGE.**

A WAR MAP!!!

There is also A WAR MAP WAITING FOR YOU. Bring the crowds from the map at the newspaper office to the one in front of **YOUR** theatre. **THIS REALISTIC, COMPLETE WAR MAP WILL DO IT.** (One sheet size)

PORTRAIT POSTERS

MORGAN PORTRAIT POSTERS ARE **WORKS OF ART, EVERY SINGLE ONE.** Be sure that the name MORGAN is on your PORTRAIT POSTER, as a great many cheap imitations are flooding the market.

GET RIGHT ON THE JOB AND CLINCH THE MORGAN PROPOSITION

WRITE

THE MORGAN LITHOGRAPH CO., Cleveland, Ohio

OR

Service Department

THE UNIVERSAL FILM MANUFACTURING COMPANY

1600 Broadway

Carl Laemmle, Pres.

New York, N. Y.

The Old Fogey



A 3-part American drama made by Pathé. Say, do you ever think of that golden well-loved day in the long ago when you went down the dusty road all bordered with white and yellow daisies, on your arm a fair young girl in pink, and your goal the great white tents of the circus? The air vibrated with the hooting of the calliope and the barking of the Ballyhoo men, and your heart vibrated in harmony. That's just what the old fogey did in this circus picture, but the girl in pink left him to follow a lion tamer and lived her life under the "big top." When she came back many exciting things happened. A film that all will enjoy. 1-3-6 sheet posters.

Whiffles Has a Toothache

An uproar in 1 reel. The only Whiffles has trouble with his tooth and with a dentist, yes, and with his employer and also the police. You could tell it was a comedy for blocks.

The Perils of Pauline

We would like to introduce you to the most charming, talented and entertainingly daring character on the screen, but you know Pauline already. So does everybody. It remains only for you, Mr. Exhibitor, to turn her general popularity into personal profits. She certainly draws the crowds.

IT PAYS TO PLAY PAULINE

A Soldier's Duty

A 3-part drama. Given a soldier trained to consider duty to his country of more importance than life itself, and you'll find that even love with him must take a second place. So in this fine film the soldier sacrifices his love for a beautiful girl in order to follow the path of duty, which leads to the grave. Superb backgrounds and photography, fine story and acting make this a film to be remembered. 1-3-6 sheet posters.

The Pathé Daily News

The film that makes a reputation for the exhibitor and friends with the public

ECLECTIC FEATURE FILM EXCHANGES FOR YOUR USE

ATLANTA 61 Walton St.	CLEVELAND 622 Prospect Ave., S. E.	LOS ANGELES 114 E. 7th St.	NEW YORK 115 E. 23rd St.	PITTSBURGH 715 Liberty Ave.	SEATTLE 810 Third Ave.
BOSTON 3 Tremont Row	DALLAS Andrews Bldg.	MINNEAPOLIS 4th and Hennepin Sts.	OMAHA 1312 Farnam St.	PORTLAND 392 Burnside Ave.	ST. LOUIS 3210 Locust St.
CHICAGO 5 So. Wabash Ave.	DENVER Nassau Bldg.	NEW ORLEANS 910 Gravier St.	PHILADELPHIA 1235 Vine St.	SALT LAKE CITY 68 South Main St.	SYRACUSE 214 E. Fayette St.
CINCINNATI 217 E. 5th St.	KANSAS CITY 928 Main St.			SAN FRANCISCO 67 Turk St.	WASHINGTON 7th & E Sts., N. W.

THE ECLECTIC
110 West 40th Street



FILM COMPANY
New York City

"The Cream of American and European Studios"

NOVEMBER 7, 1914

Motion Picture News

HAS THE QUALITY CIRCULATION OF THE TRADE

JESSE L. LASKY

PARAMOUNT PRESENTS PICTURES

THE EVER POPULAR ARTISTE

EDWARD ABELES IN JAMES MONTGOMERY'S INTERNATIONAL SUCCESS **“READY MONEY”**

5
ACTS
OF
SURPASSING
DRAMATIC
ACTION



RELEASED
NOVEMBER
5TH

JESSE L. LASKY FEATURE PLAY COMPANY

LONG ACRE THEATRE W. 48TH STREET N. Y. C.

JESSE L. LASKY SAMUEL GOLDFISH CECIL B. DeMILLE
 PRESIDENT TREAS. & GENL. MANAGER DIRECTOR GENERAL



J. Warren Kerrigan in
"HIS HAND, HIS HEART,"

HIS SWORD

TWO REEL VICTOR DRAMA

FIRST STORY IN THE SERIES entitled

TERENCE O'ROURKE,

GENTLEMAN ADVENTURER

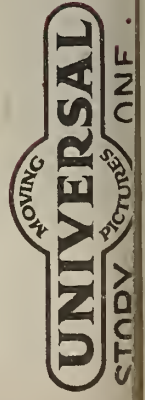



DANIEL FROHMAN
Presents
The inimitable

JOHN BARRYMORE



in H.A. Du Souchet's
famous farce,

"THE MAN FROM MEXICO."

"THE MAN FROM MEXICO,"
-the play that made the country laugh.

A comedy of ludicrous dilemmas and laughable misfortunes,
In Five Reels of Motion Pictures
Released November 2nd.

Produced by the

FAMOUS PLAYERS FILM CO

ADOLPH ZUKOR, President,
DANIEL FROHMAN, Managing Director EDWIN S. PORTER, Technical Director
Executive Offices,
213-229 W. 26TH STREET, NEW YORK.



A GOOD HAND TO HOLD

THE WEEK OF NOVEMBER 1st



Released Exclusively Through the Mutual Film Corporation

PHOTOS—8 by 10 photos of the following players can be had by sending to the PUBLICITY DEPT. 15 cents for one, 50 cents for set of four, one dollar for set of eight, etc.

Mabel Normand	Charles Ray	Elizabeth Burbridge	Sid Chaplin
Barney Sherry	Roy Laidlaw	Mack Sennett	Roscoe Arbuckle
Thos. H. Ince	C. N. Mortenson	Walter Belasco	Shorty Hamilton
Enid Markey	Charles Chaplin	John Keller	W. S. Hart
Richard Stanton	Margaret Thompson	Jay Hunt	Walter Edwards
Leona Hutton	Frank Borzage	Jerome Storm	Gertrude Claire
Rhea Mitchell	Harry Keenan	Webster Campbell	J. Frank Burke
			Herschel Mayall

KEYSTONE MABEL IN TEN NEW STYLES—15 cents for one, 50 cents for set of four, etc.

PENNANTS—Beautiful colored pennants of our four brands, **KAY BEE**, **KEYSTONE**, **BRONCHO** and **DOMINO**. 25 cents for one, one dollar for set of four.

New York Motion Picture Corporation

Longacre Building, 42nd St. and Broadway

NEW YORK

AD KESSEL, Jr., President

FAMOUS PLAYERS FILM CO

In Association with
Daniel Frohman
Chas. Frohman-Henry W. Savage

THE PRODUCTIONS OF
JESSE L. LASKY FEATURE
PLAY CO.

Associated with
David Belasco
The Liebler Company
CONSTITUTE

BOSWORTH INC.

Associated with
Lois Weber
Phillips Smalley



Paramount Pictures

Throughout the United States **Paramount Pictures** are daily bringing people to Moving Picture Theatres.

A certain number of the people in your city are regular patrons of Motion Picture Shows.

This number is daily increasing in **Paramount Theatres** because of the superiority of **Paramount Pictures**.

Do you wish to increase the attendance at **your** theatre? If so, secure **Paramount Pictures now**.

Write our nearest exchange today for information about bookings

Paramount Pictures Corporation
ONE HUNDRED and TEN WEST FORTIETH STREET
NEW YORK, N.Y.



V. TROTTA



THE SECOND MRS. TANQUERAY

Arthur Maude and Constance Crawley
in a powerful film production of
Sir Arthur Wing Pinero's famous drama.
Superb acting and a splendid setting.
..Two parts..

WARNER'S FEATURES, Inc., New York



COMEDIES—Features—Specials—Every reel of the high standard established by our famous feature releases. There are 42 Warner's Exchanges. Write the one nearest you.

Atlanta, Ga.
Baltimore, Md.
Boston, Mass.
Buffalo, N. Y.
Calgary, Can.
Cleveland, Ohio
Charlotte, N. C.
Chicago, Ill.
Charleston, W. Va.
Cincinnati, Ohio

Dallas, Texas
Denver, Colo.
Des Moines, Iowa
Detroit, Mich.
Edmonton, Can.
El Paso, Texas
Indianapolis, Ind.
Kansas City, Mo.
Los Angeles, Cal.
Louisville, Ky.

Minneapolis, Minn.
Montreal, Can.
Nashville, Tenn.
Newark, N. J.
New Orleans, La.
New York City
Omaha, Neb.
Philadelphia, Pa.
Pittsburgh, Pa.
Portland, Me.

Portland, Ore.
San Antonio, Texas
San Francisco, Cal.
St. Louis, Mo.
Seattle, Wash.
Spokane, Wash.
Syracuse, N. Y.
Toronto, Can.
Washington, D. C.
Wilkes Barre, Pa.
Winnipeg, Can.

Main European Office: 99 Charing Cross Road, London, W. C.

WARNER'S FEATURES, Inc.

New York

The TAINT



A 4-part American drama. The story of a woman who makes a stand against the blackest sort of circumstantial evidence. From start to finish a succession of gripping dramatic situations which lead to a splendid climax. Full justice is done to this powerful play by an exceptional cast—Ruby Hoffman, Edward José, and Creighton Hale are featured. The wreck of the locomotive and the death of the villain will cause a jolt to the most sated playgoer. 1-3-6 sheet posters.

In a Difficult Position and Whiffles' Nightmare

A double comedy split reel. To add the proper touch of fun. This film will find the floating rib of the most sombre-minded man in your audience. 1 sheet posters.

Mother's Darling Little Boy

1 reel comedy by the All Comedy Films, Inc. Real boy life as played by a real boy. Mother never suspected her darling till—well, mothers will open their eyes. 1 sheet posters.

The Perils of Pauline

How would you like to bring back every patron who has ever been in your theatre? That's what Pauline will do for you. Everyone who sees Pauline wants to see her again, and the best part of it is they can, and you can show her to them. **PAULINE SETS THE PACE IN BOX-OFFICE RECEIPTS.**

The Perfect "36"

Introduced by Montague Glass

A 4-part comedy. A refreshingly laughable story with screamingly funny titles by Montague Glass. The perfect "36" is perfect also in other respects—too perfect for her aunt's rural store. As a cloak model in the city she is also perfect—too perfect for a dairy lunch, but she finds her own level at last. 1-3-6 sheet posters.



ECLECTIC FEATURE FILM EXCHANGES FOR YOUR USE

ATLANTA 61 Walton St.	CLEVELAND 622 Prospect Ave., S. E.	LOS ANGELES 114 E. 7th St.	NEW YORK 115 E. 23rd St.	PITTSBURGH 715 Liberty Ave.	SEATTLE 810 Third Ave.
BOSTON 3 Tremont Row	DALLAS Andrews Bldg.	MINNEAPOLIS 4th and Hennepin Sts.	OMAHA 1312 Farnam St.	PORTLAND 392 Burnside Ave.	ST. LOUIS 3210 Locust St.
CHICAGO 5 So. Wabash Ave.	DENVER Nassau Bldg.	NEW ORLEANS 910 Gravier St.	PHILADELPHIA 1235 Vine St.	SALT LAKE CITY 68 South Main St.	SYRACUSE 214 E. Fayette St.
CINCINNATI 217 E. 5th St.	KANSAS CITY 928 Main St.			SAN FRANCISCO 67 Turk St.	WASHINGTON 7th & E Sts., N. W.

THE ECLECTIC
110 West 40th St.



FILM COMPANY
New York City

"The Cream of American and European Studios"

THE
PATHE



A SCENE FROM THE FRONT

DAILY
NEWS

NEWSPictures made by
Pathé have a larger
following and a wider circu-
lation than any motion pic-
tures in the world. Make
friends with your public
—show

THE PATHÉ DAILY NEWS
T W I C E A W E E K !

Now To Be Obtained Through

THE ECLECTIC



FILM COMPANY

110 West Fortieth St.

NEW YORK CITY



**FOUR STRONGEST RELEASES
EVER OFFERED
IN ONE MONTH**

The Kinetophote Announces for November:

“THE SPIRIT OF THE POPPY”

(SIX PARTS)

Moral Photoplay Extraordinary!
With **EDWARD MACKAY**

Sutton Vane's
Famous Drama
on The Screen

“THE SPAN OF LIFE”

Great as a Play
Greater as a
Picture

(FIVE PARTS)

With **LIONEL BARRYMORE** Assisted by
GLADYS WYNNE

“THE COMING POWER”

(FOUR PARTS)

Timely Story of Political Intrigue

Thrilling in
Every Part

“THE LITTLE JEWESS”

A Tale that
Reaches the
Heart

(FOUR PARTS)

Future Bookings ARE Going Fast

<i>Feature</i>		<i>Productions</i>
----------------	---	--------------------

Ira H. Simmons, Gen. Mgr.

Telephone: 6072 Bryant 126 WEST 46th STREET, NEW YORK CITY





THE MILLION DOLLAR MYSTERY

Story by Harold MacGrath
Scenario by Lloyd Lonergan

Thanhouser's Million Dollar
Motion Picture Production

The Million Dollar Mystery has been a greater drawing-card for exhibitors than any motion picture production ever brought out. *Mark that!* This production positively has played to bigger audiences than have ever attended the movies.

Twenty episodes are now appearing everywhere. The entire story will take 23 episodes. Episode No. 23 will be written from the best solution of the mystery. 300 leading newspapers are running this story.

Exhibitors who are seeking a real attraction—*one that is bound to pack houses*—must make arrangements *at once*. This is an independent release and may be obtained regardless of the regular program being used. Apply to

Syndicate Film Corporation

71 West 23rd Street, New York

Room 411, 5 S. Wabash Avenue, Chicago

or Syndicate Film Corporation Representative at any Mutual Exchange in the United States and Canada

The Thanhouser Three-a-Week

Following are the Thanhouser releases for the current week. These releases are distributed exclusively in the United States and Canada by the Mutual Film Corporation.

Tuesday, November 3rd, "The Turning of the Road" (two reels). This is a powerful drama of society life. It portrays the actions of a band of thieves who work among the best society. A member of the band—Della Fletcher—is the character around which the plot revolves. Her stealing of the gems and her ultimate reformation and marriage to a handsome rector form a basis for many tense scenes. She is led by love out of the shadows into the light and the turning of a new road. The cast includes Muriel Ostriche, Frank Woods, John Reinhard, Ethyle Cook, Ernest Ward, Carey Hastings, Arthur Bauer, Perry Horton.

Sunday, November 8th, "Keeping a Husband" (one reel). A decidedly clever drama of home life, showing how a wife's strategy makes it possible for her to retain her husband's love in spite of severe temptations. This photoplay is very capably enacted by Mauriel Ostriche, Carey L. Hastings and Ernest C. Ward.

Thanhouser Film Corporation

New Rochelle, N. Y.

Head European Office, Thanhouser Films, Ltd.
London, W. C., England



WHY DID JUNE RUN AWAY?

WHY DID JUNE RUN AWAY?

WHY DID JUNE RUN AWAY?

WHY DID JUNE RUN AWAY?

WHY DID JUNE RUN AWAY?

WHY DID JUNE RUN AWAY?

WHY DID JUNE RUN AWAY?

WHY DID JUNE RUN AWAY?

WHY DID JUNE RUN AWAY?

WHY DID JUNE RUN AWAY?



EDISON



A QUESTION OF IDENTITY

A Dramatic Adaptation of "The Window that Monsieur Forgot"
 By CHARLES IMLAY TAYLOR

Here is a film of thrilling dramatic interest. Twin brothers so much resemble each other that in the culmination of the criminal career of one the question of identity was exceedingly difficult to decide. One had murdered the Chevalier but had escaped immediate arrest. The other brother was charged with the crime. Which was which? The final scene in the Police Court, where sentence was about to be passed upon the innocent brother, is halted by the arrival of the dead brother's body, for he had resisted arrest after being hunted down by witnesses to the affair. A thrilling film throughout. The air of reality will cause this film to be widely commented upon.

In two parts. 2,000 feet. To be released Friday, Nov. 13th

COMING EDISON RELEASES

Mon.,	Nov. 9th—	"With Slight Variations".....	Comedy, 1,000 ft.
Tues.,	" 10th—	"The Heritage of Hamilton Cleek".....	Drama, 1,000 "
Wed.,	" 11th—	"Andy Falls in Love".....	Comedy, 1,000 "
Fri.,	" 13th—	"A Question of Identity," in two parts.....	Drama, 2,000 "
Sat.,	" 14th—	"The Everlasting Triangle".....	Drama, 1,000 "
Mon.,	" 16th—	"The Adventure of the Lost Wife".....	Comedy, 1,000 "

Order Edison Posters of the Morgan Lithograph Co., Cleveland, Ohio, direct



TRADE MARK
Thomas A Edison
 Makers of the Edison Kinetoscope,
 Model "D"

THOMAS A. EDISON, Inc.
 275 Lakeside Avenue, Orange, N. J.





Thanhouser's Greatest Photoplay

This wonderful new serial production has created a sensation among exhibitors. Although the first release date is November 23rd, hundreds of bookings have already been made.

ZUDORA will be produced in 20 episodes. A two-reel episode will be released each week beginning Nov. 23. The photoplay is by Daniel Carson Goodman. The story is by Harold MacGrath. 500 leading newspapers will publish the story. 3000 scenes will be used. The cast of 1000 people includes beautiful Marguerite Snow as ZUDORA, James Cruze as Hassam Ali—the Hindu Mystic—and Harry Benham as the hero.

Exhibitors: Book Quickly!

This new Thanhouser serial promises to be an extraordinary success. You know what The Million Dollar Mystery has done for you. Now Thanhouser presents another opportunity. Are you going to get in early—NOW—or are you going to be disappointed? Arrange your bookings for ZUDORA *at once* by applying to the Thanhouser Syndicate Corporation's representative at any Mutual Exchange in America. Or write to



Thanhouser Syndicate Corporation

71 West 23rd Street, New York City

Produced by

Thanhouser Film Corporation, New Rochelle, N. Y.

Producers of The Million Dollar Mystery



"When You See It
In 'The News'
It's NEWS"

Motion Picture News

"The Exhibitors'
Medium of
Communication"

HAS THE QUALITY CIRCULATION OF THE TRADE

Tel. 7650 Bryant

NO. 220 WEST FORTY-SECOND STREET

New York City

Volume X

NOVEMBER 7, 1914

Number 18

Live Wire Circulation

A STATEMENT made several weeks ago on this page—that there were about 7,000 *purchasing* exhibitors—seems to be misunderstood by a few.

We have been variously accused of killing off exhibitors, of attempting to make the number fit our circulation, and so forth, and so on.

* * *

IT was not stated that there were only 7,000 exhibitors—but 7,000 *purchasing* exhibitors.

For the benefit of our contemporaries, let us explain that a *purchasing* reader means a reader responsive to advertisements. The word has been used in advertising circles since the Year One.

* * *

LET us further explain. Many readers are not responsive. That generally happens where they don't get a paper at all, or where they get it free.

In other words, *when they don't read it*. Free circulation is little better than no circulation. It doesn't acquire *responsive* readers.

* * *

A READER is only responsive to the advertising pages of a publication when that publication is read by him *straight through*, when it is conducted altogether in *his* interests and therefore has his *confidence*.

He *pays* for such a publication because he *needs it in his business*. It is his reading and buying guide.

* * *

PERHAPS we should have said *live wire* exhibitors, instead of *purchasing* exhibitors, but the two have just exactly the same meaning.

A *live wire* exhibitor is a *purchasing* exhibitor; he buys new ideas, good pictures, efficient equipment, courteous employees, attractive environment, advertising—and last, or rather, first—a trade journal *to tell him about these very things*.

* * *

IF you can't sell an exhibitor a trade journal, you can't sell him *any* first-hand high-class article.

He is, except for a cheap service and second-hand equipment, a non-purchaser.

* * *

SO far as the number of exhibitors in the country is concerned, we have a list of 15,821 to date. It has been compiled and is kept up to date through many avenues of information. We consider it the

best list in existence because we constantly check it. But we don't take it seriously; nor do we ask others to regard it so.

We know how it fluctuates—every day—so that a big percentage changes completely every six months. And we know that a bigger percentage still of theatres is impossible to the advertiser and to ourselves.

* * *

OUR statement of 7,000 *purchasing* exhibitors is based upon a mail campaign of a year's duration and upon the personal investigations and reports of over a hundred field representatives.

It is not far wrong.

A man, who for seven years has been a territorial and local exchange manager for the General, Mutual and Universal companies fixes the number at 7,500.

* * *

WE accept the amendment. Also, the number—happily—is increasing.

The fakir, the floater, the "dead one"—the man who adds only to the *number* of theatres and not to their *quality*, is fast dying out.

Naturally so, and as he disappears the live wire exhibitor is increasing in numbers and prosperity.

* * *

HE, the live wire, *purchasing* exhibitor, is the backbone and ribs of the industry.

He is putting back into it the money it demands for its maintenance.

He is extending it because of his good services to the public.

He is the man worth while.

* * *

NUMBERS mean nothing.

The statistics of 15,000, 17,000, 20,000 picture theatres (based upon amusement licenses and unverified newspaper clippings) are of value only to the magazine writer, the stock-jobber and the circulation booster.

To the trade they are misleading.

* * *

EVERY manufacturer and exchange man with a knowledge of field conditions knows they are wrong.

They *know* the figures of 7,000 *purchasing* exhibitors are right.

Why continue the deception?

WILLIAM A. JOHNSTON.

COAST THEATRE FOR WOMEN NOT A SUCCESS

Special to MOTION PICTURE NEWS

Los Angeles, Oct. 26.

A "women-only" motion picture theater in Los Angeles is not a financial success. Early in August the small four hundred seat theater on Broadway, between Fifth and Sixth streets, owned by the Clune Amusement Company, was opened, after being remodeled inside and out, as the the Exclusive.

It was widely advertised that this theater was for women and children only, and that men would be admitted only in company with women. First, a program of educational pictures was tried. Later comedy reels were used, and last a general program of comedy, drama, and educational was shown, but the attendance was not good.

This house was originally a five-cent drop-in place, and it has now been changed back to that policy and price. A Mutual program is now being shown, and the theater has been placed in charge of W. W. Dunlap, who has been identified with some of the most profitable picture theaters in Los Angeles.

SYRACUSE CENSOR WORKS WITH EXHIBITORS

Special to MOTION PICTURE NEWS

Syracuse, N. Y., Oct. 29.

Policeman Edward Smith is the real motion picture censor in Syracuse.

When Smith was asked how he got along so pleasantly with the exhibitors, he said:

"Well, I never stopped to think about it but I suppose it's just because we work together. I never come into a house and order a picture taken off, because Syracuse exhibitors 'phone me before booking any picture regarding which there is a shadow of a doubt about passing.

"I look it over and that man's chances of securing my O. K. are five hundred per cent. better than if he showed the feature without first being sure.

"I read the criticisms in THE MOTION PICTURE NEWS and keep pretty well posted in advance. Co-operation is the secret of my success."

MINDER ELECTED PRESIDENT ROCHESTER BRANCH

Special to MOTION PICTURE NEWS

Rochester, N. Y., Oct. 28.

The Rochester branch of the Motion Picture Exhibitors' League has elected officers as follows:

President, W. J. Minder, National Theatre, Jay street; vice-president, W. A. Calihan, Hippodrome Theatre, Main street east; secretary, W. C. Hubbard; treasurer, F. C. Gerling, Knickerbocker Theatre, Main street east.

The retiring president, A. N. Wolff, gave satisfaction to all hands, but requested that the work be shared by someone else. He is still president of the state branch of the league.

Maryland League Checks Price-Cutting

With Co-operation of Exchanges, President Pearce and Baltimore Exhibitors Halt Manager's Attempt to Put on a Two-Cent Program

Special to MOTION PICTURE NEWS

Baltimore, Oct. 29.

THE effectiveness of the Maryland State Branch of the Motion Picture Exhibitors' League of North America was demonstrated last week when the members of the league with the co-operation of exchange men forced at least one exhibitor to discontinue a rather demoralizing practice. The latter exhibitor is not a member of the league and conducts a small motion picture house in South Baltimore.

He inaugurated a plan by which he gave out coupons each evening, which coupon and two cents was good for a performance the day following. It was in fact nothing more or less than a two-cent admission for which the exhibitor presented five or six reels of pictures. This practice, while not particularly successful as far as patrons were concerned, had a demoralizing effect upon the followers of pictures in the southern section of the city, and, of course, made it very undesirable for the picture men doing a legitimate business in that part of the city.

Marion S. Pearce, president of the Maryland branch as well as the president of the National organization, was communicated with and the matter was placed before him and other members

of the executive committee. A meeting was called at which the exchange men and feature men were invited to attend. The proposition of the two-cent admission was presented to them and they all agreed that it was a very undesirable condition and that they would co-operate with the members of the Maryland branch to stamp out this practice among the smaller motion picture exhibitors.

The exchange men immediately notified this South Baltimore exhibitor that his film would be discontinued at the end of last week. The exhibitor wanted to know the reason why and upon being told that the exchanges absolutely declined to supply a two-cent picture show he immediately pledged himself to charge the regular admission in the future.

At a meeting held at the Maryland Exhibitors' League on October 20 the announcement was made that the two-cent admission proposition was a thing of the past and aroused considerable enthusiasm. It was not so much the elimination of this one undesirable feature that caused enthusiasm among the Maryland exhibitors, but it was the spirit of progress and timely co-operation that they had received from the managers of the Universal, Mutual and Warner's Feature exchanges.

A. F. GILLOSPEZ.

Cory Will Be California Organizer

Plans State-Wide Membership Campaign with Reduction of Initiation Fee—Predicts 100 Per Cent. Increase or More Before January 1

Special to MOTION PICTURE NEWS

San Francisco, Oct. 26.

AT the third annual convention of the Motion Picture Exhibitors League of California, held in San Francisco, the following officers were elected:

President, H. L. Beach, of Berkeley; vice-president, Judge A. P. Tugwell, of Los Angeles; national vice-president, W. H. Hilts; secretary, W. A. Cory, and treasurer, C. L. Mehrten.

Leo Kaufmann, chairman of the committee on organization, rendered a report that set forth the need for an enlarged membership, together with plans for consummating this. The report stated that to secure new members it would be highly advisable to place an organizer in the field.

It was recommended that the position of state organizer be established and that a fund be raised at once to send this official into the field at the earliest possible moment.

Judge A. P. Tugwell expressed hearty accord with the report of the committee and this was unanimously adopted. The Judge then delivered an eloquent address, during which he told of some of the measures that would be introduced into the next legislature, affecting the motion picture industry.

He stated that he knew that a Sunday closing bill would be brought forward, that a drastic state censorship bill would be introduced, and that the sixteen-year limitation bill would again come up, with possibly one having for its object the segregation of men and women in moving picture theatres. He described the proposed State censorship law in detail, declaring that it would be the most drastic ever drawn.

Following this speech contributions were asked for an organization fund and within a few minutes two hundred dollars was collected.

W. A. Cory, who has been secretary for several years, and who is now more at liberty than formerly through the sale of his interests in the Fairyland Theatre, has consented to take up this work and is now in the field. He has mapped out an extensive trip and within the next few months plans to visit almost every section of the State, first visiting, of course, the large centers of population.

The initiation fee has been reduced for this campaign and it is predicted that by the first of the year the membership will have been increased by more than one hundred per cent.

M. L. LANGHORST.

EXHIBITORS TALK ORGANIZATION FINANCE

Brylawski Believes \$2 Per Capita Tax for State League Members Is Sufficient—Milwaukee Manager Urges Salary for Officers; Tax of One Dollar a Month on State League Men Not Too High, He Declares—Organization Needs Capital

Special to MOTION PICTURE NEWS

Washington, D. C., Oct. 28.

FULTON BRYLAWSKI, secretary of the Exhibitors League of the District of Columbia, and vice-president of the National League, is a man of wide experience in organization affairs, so his views regarding the present situation of local and national matters will carry food for thought. In speaking to him on this subject, Mr. Brylawski had this to say:

"The officers of the Motion Picture League of the District have had the same experience regarding attendance at meetings and the interest manifested at such gatherings as have fraternal organizations.

"There is a very marked tendency for the exhibitors in general to allow the actual work of running the affairs of the league to devolve upon a dozen or more members—and the same dozen or more all the time.

"Thus it is almost impossible to secure a complete attendance at the meetings unless there is some form of entertainment or some danger which threatens the individual pocketbook.

"To overcome this situation, our League is at present considering the advisability of amending its constitution and by-laws, so that the affairs of the league may be almost exclusively executed by a committee, and the full membership should only meet four times a year. These quarterly meetings would be partly social gatherings and partly business meetings. The next regular meeting of the local league will be called at some cafe or restaurant, and if the proposition is successful, an executive committee will direct the future affairs of the league."

Some Members Let Dues Slide

Speaking of the financial situation, Mr. Brylawski said: "Of course there are many members of poor standing in the league, in spite of the small amount of our dues. In cases of emergencies, the District exhibitors have always gotten together and raised the necessary amount, but in the absence of any such spirit, there is a tendency to let dues slide.

"We have hope of very materially improving our financial situation from the proceeds of the ball to be given in Convention Hall on October 31. This will also take the form of a reception as well, as we expect to have about fifty photoplay stars from various studios as our guests."

The secretary also stated that the league had in many cases been of service to its members in legal matters when censorship, Sunday closing, license and building privilege had arisen.

"It was only recently," he went on, "that one of our members was fined \$100 for showing the Essanay release of 'The Coming Champion Who Was Delayed.' It was alleged by the officer that the film was in violation of the local regulation against showing pictures of prize fighting.

"As a matter of fact, there is not one bit of fighting in the film, and when I brought the matter to the attention of the corporation counsel and had the reel run off for him, the case was closed without a hearing in court."

Two Dollar Per Capita Tax

"So far as the National League is concerned with regard to finances," commented Mr. Brylawski, "I believe that a per capita tax of \$2 for each member of the State League organization is quite sufficient. And, indeed, the

value to them until there is an organization effected.

"Until they make the exhibitor who is at present outside of the national body realize that he cannot get along without the organization there will never be a chance of getting him into the fold," said Mr. Fischer.

"How do I think the State League can best serve its members? Well, that is a pretty broad question, as there are many ways in which an organization of this sort can benefit its members, but to my mind a State League can do the most good by combating adverse legislation and boosting the picture business as a whole by a statewide publicity campaign.

"To finance the State League I think that where there is a local organization one-half of the dues should go to the state association and in case of the individual members they should be assessed an initiation fee and monthly dues."

League Should Keep Out of Politics

"The State League should by all means keep out of politics and not endeavor to get any of its members into the state legislative body. The principal reason for the lamentable lack of interest shown by the Wisconsin exhibitors in any of the numerous get-together movements that have been started has been the petty squabbles between the exhibitors, which they seem unable to forget.

A local organization in which every member puts up a bond of at least \$100 as a guarantee of his good faith and his willingness to abide by the will of the majority and one in which all members who do not attend the meetings would be fined, is the suggestion of Gene Olinger, owner of the American theatre. Mr. Olinger would go even farther and provide a salary for all of the officers who performed active work for the league.

Salary for Organization Officers

"Until the day arrives," said Mr. Olinger, "that all the exhibitors put up a bond of good faith of, say, \$100, and until they know that it will cost them money to stay away from the meetings, I doubt that there will ever be an effective organization of exhibitors.

"The present national organization has not done anything for the exhibitor and has been unable to prevent any adverse legislation from becoming effective.

"The best way to build up an effective State League is not to work for numbers but for substantial members, members who can and will back up their words or actions and who are able to give bond. Then it would be possible

WHERE TO FIND IT

Department	Page
Live Wire Exhibitors.....	25
Among the Exchanges.....	31
In and Out of Los Angeles	
Studios	35
Editorials	43
Feature Reviews.....	39-42, 45-47
Program Reviews.....	50, 51, 52
Buyers' Guide	57
Current and Coming Releases,	58, 60
Release Dates for Ready Reference	62, 64, 66

amount must be kept small if we hope to bring others into the fold. While some realize that the payment of dues is not sufficient to properly maintain the national officers, this fund could be largely supplemented by annual expositions, provided they are held in the larger cities.

"The two expositions in New York and the one in Chicago were all very successful, financially, and their success may be repeated yearly under proper and careful management. In this manner, the finances of the national organization could be amply taken care of."

THEODORE FRANKLIN.

Want Men Who Can Put Up \$100 Bond

Special to MOTION PICTURE NEWS

Milwaukee, Wis., Oct. 27.

GEORGE FISCHER, manager of the Alhambra theatre, and one of the most conservative of local exhibitors, says that the national organization has been of absolutely no value to exhibitors and that it will never be of any

to organize a State League that could pay its officers or members for any work they did for the league and thus get the best from its workers.

"I think that the league should by all means go into politics, put up its ticket, and get after the grafters and would-be reformers. A State League should by all means accomplish things of value for its members, but it must first make these members attend the meetings, and the only way that this can be done is by having the members put up a bond and then be liable to a fine in case they do not attend the meetings.

"All matters of importance should be submitted to the members for a direct vote, which can be done where all members attend the meetings, and not be left to the decision of an executive board, as this method is likely to put all the power into the hands of one man or a clique.

"To properly finance a league in this state I think that the members should be taxed at least one dollar a month and also be liable for assessment not to exceed twice the amount of the monthly dues. In this way an organization could be perfected that had some capital and could do much good work."

Only One Organization

Otto Meister, of the Vaudette theatre, says that he believes in no organization outside of the National League, and that if the state or city exhibitors ever want to combat any evil they can always get together and fight that particular evil, but there is no need of keeping a permanent organization.

"Though against anything but the national organization," said Mr. Meister, "if a State League is organized I would like to see it go into politics, either putting its own man up for the legislature or getting certain candidates to put themselves on record as to how they stand in regard to the motion picture industry. A State League, however, should confine itself strictly to the legislative end and should not interfere with the exchanges or the film men."

J. W. MARTIN.

Butte Sees Salvation in Unity

Special to MOTION PICTURE NEWS

Butte, Mont., Oct. 27.

PHILIP LEVY, manager of the Ansonia Amusement Company, of this city, controlling the Ansonia, Orpheum and Princess theatres, and president of the Montana State Exhibitors League, is an ardent booster for a greater State League and a greater National League of motion picture exhibitors and is a believer in the theory that the success of the one means the progress of the other. He said to a representative of MOTION PICTURE NEWS:

"Picture men need the State League as a means of introduction of one to the other, to exchange ideas, to promote a better understanding of the wants of the public, to fit the individual members

for the business of conducting picture houses, to elevate the tone of the shows, and to give better satisfaction to the public.

"It may be that the State Leagues are not as good as they ought to be. Why? The fault lies with the members. Closer union, more frequent meetings, interest in the work, frequent exchange of ideas, cordiality, sympathy and kindness will put the State League into a position of being of more assistance to the individual members.

Efforts of the Few Not Enough

"Unfortunately, too, many want to stand aside and let the others do the work. Success can only be attained by the united efforts of the various picture men all pulling together. The efforts of a few will never bring satisfactory results. With good State Leagues the

National League will be of the dimensions and effectiveness it deserves to be from the magnitude of the interests it represents.

"A thorough campaign of education along the lines suggested by MOTION PICTURE NEWS will be admirable. If we could only interest ourselves more in what others are doing, the others would soon fall in line and the result would be magnificent State Leagues, a gigantic National League, more pleasure and profit in our work and a higher general standard in the motion picture business.

"I would say for a starter—let each exhibitor learn all he possibly can about every other exhibitor in his state. When we know one another better we will be pleased to meet oftener."

JAMES CUMMINS.

Rochester Operators on Verge of Strike

Booth Men Ask for \$20 a Week with Extra Pay for Overtime, But Exhibitors Consider Demands Too One Sided

Special to MOTION PICTURE NEWS

Rochester, N. Y., Oct. 28.

TRADE unionism is the big issue now facing the Rochester exhibitors. Are they to be allowed to run their houses themselves, or are they to turn them over to the operators' organization. That is the question that is before the exhibitors now, and is one that must be settled definitely very soon.

So far the exhibitors have not given in to the demands of the operators. The latter have a new union, and are trying to enforce a new scale of wages, and to put into force an agreement that the exhibitors claim is very one sided.

Both sides have conferred with the city officials. Mayor H. H. Edgerton has extracted a promise from the operators that they will not call a strike without first giving him notice, and an opportunity to try to adjust matters between the owners and their employees.

Objectionable features contained in the agreement submitted by the union are that none but union operators shall be employed; that the union shall permit but one apprentice for each ten houses; and that no man shall be dismissed without a week's notice, except for a cause deemed sufficient by the representatives of the union.

The situation is complicated by the fact that all but a very few of the men licensed by the city board to run motion picture machines are members of the union, and that the state law and city ordinances prohibit any but licensed operators from running machines.

The city licensing board has conducted a series of examinations in the past three months, and has licensed about seventy-five operators. Very few of the owners or managers of houses took the examination, though a few had that forethought.

It is now rumored that the owners and managers will shortly ask for a special examination, so that they may

try the test and obtain licenses. Thus, in the event of trouble, they could run their machines themselves, without running the risk of a \$100 a day fine.

It looks as though the owners are determined not to sign the proposed agreement, and the next move is up to the operators. The owners and managers made several counter proposals to the operators all, of which were rejected. They then notified the operators that, as an association, it refused to accept the agreement. The operators then said they would deal with the owners individually.

The operators have determined to enforce the scale which they were authorized to enforce months ago, \$20 a week for each operator doing a dull trick in a downtown house, with extra pay for overtime, and \$17 a week for operators in outside houses, which give only evening performances, except on Saturday.

Outside houses have been paying \$15 per week to operators for nights and a Saturday matinee, with \$2.50 extra for each extra matinee put on. The new scale calls for \$17 a week for nights and Saturday matinee, with but \$2 extra for each additional matinee. The downtown houses, which require two operators, must pay \$20 per week for each man, for a show opening at noon, with 50 cents an hour additional for each extra hour in the morning.

ARTHUR R. TUCKER.

DENIES RIGHTS TO COSMOS FILM

The Exhibitors All Feature Film Company, Arkay Building, Albany, N. Y., has published a circular to the effect that it controls rights to certain features in the state of New York and among them it has the recent production of "Lena Rivers."

The Cosmos company states that the Albany concern does not control any right to book the play.

THE THEATRE THAT REFORMED A DISTRICT

St. Louis Manager Sees Possibilities in a Locality Shunned by Other Exhibitors—His Success Demonstrates the Truth That Daring Enterprise Backed Up by Good Judgment Always Wins Out—Clean Pictures Appreciated in a Drab Neighborhood

THE Retina Theatre is at Twentieth and Market streets, just alongside the St. Louis union station. Now union stations, like everything else, have good and bad sides, and the Retina is on the other side of this great passenger depot, not anywhere near the great marble pillars, and gold and white vestibules, where rich travelers and tourists enter and exit on their way to their palatial trains.

The Retina is nearer the side where the poor emigrant and the day coach traveler is likely to be found.

A few years ago the district surrounding Twentieth and Market streets was not well lighted; there were many saloons, and a mixed population of negroes and whites, and when this oil and water mixture was further complicated by the addition of foolish travelers looking for adventure, and confidence men and other light-fingered gentry looking for foolish travelers, there was much to be desired from a law and order standpoint.

The district was the scene of many holdups, many confidence games and even murders.

THEN John Gentner opened the Retina Theatre, just where Twentieth street runs into, but does not cross, Market street. Many managers would have read the people of this neighborhood wrongly, many managers would have filled them up with lurid melodrama, many would have given them cheap Westerns, or slap-stick comedy.

John Gentner did none of these things; he gave them good, clean heart interest pictures, stories with a moral as well as a punch, stories that went home and reached the hearts of these Twentieth and Market street denizens quicker and more effectively than a hundred sermons, or a hundred talks on reformation or morals would have done.

Many a wanderer waiting for a train at the station that was to carry him away, perhaps to disgrace and dishonor, stepped into John Gentner's show and read a lesson on the screen that made him go back and fight his battles, and face his music, or whatever it was that impelled him to cowardly flight.

Many a hardened criminal was turned from his purpose by the moral in one of the pictures on the Retina screen. The whole district began to change, the devil's idle mind workshops were closed for repairs, because the people were cured of their idleness. Instead of wandering around on the ill-lighted streets, they went to John Gentner's picture show.

Many of them saw people there that were better dressed than they were, and their pride of person was awakened;

many of them saw people whose manners were better, and their behavior was bettered.

DOZENS of them saved the nickels that usually accompanied the tin bucket to the gin mill on the corner, for a ticket to John Gentner's show.

The lights of the Retina made Market street as light as day, and spread their friendly rays half way up to the next block on Twentieth street.

There was too much light for the crooks and schemers; they sought other hunting grounds. The whole neighborhood felt and profited by the change, and today the block where the Retina stands is as peaceful and quiet as any in the city.

Clean pictures were not the only method John Gentner used in educating the people of the neighborhood. At stated intervals he would print booklets filled with useful information, usually of a historical or patriotic nature, something to give the people pride in their country or city.

THE date of the last distribution was on July 2, and the subject used was "The History of Our Flag." The booklet is of sixteen pages, with a beautiful reproduction of Old Glory in colors, spread all over the two middle pages.

The text of the book is very complete, and contains not only a history of the flag, but the words and music of "The Star Spangled Banner," a specimen of the original song in the handwriting of Francis Scott Key, the author, together with many pages of information about the flag, and an exhaustive treatise on its origin.

The material for the book was collected by Mr. Gentner personally, and is authentic in every particular.

The night chosen for the distribution of the booklets was the occasion of the showing of the last of the Selig serial feature, "The Adventures of Kathlyn." Two thousand five hundred were given out that night, and a slide was run to inform the public that they could be had on request.

A. H. GIEBLER.

Wireless Not Much Speedier Than Mutual Tug



"MUTUAL WEEKLY" TUG AT THE WRECK OF THE "METAPAN."

THE enterprise of the "Mutual Weekly" in gathering live news was well illustrated recently when the United Fruit steamer Metapan collided with the Iowa of the Old Dominion line in a fog in the Ambrose Channel. The "Mutual Weekly's" tug, which is always stationed in New York harbor, was on the scene almost as quickly as the wireless calls for aid were received, and captured many interesting views of the damaged steamer.

After the accident, which occurred on

Thursday, October 15, the captain of the Metapan raced his vessel for shallow water, beaching it in the sands not far from Coney Island. All the passengers, who numbered more than one hundred, were landed in safety, but much of the Metapan's cargo, which was chiefly bananas, went over the rail. Since then Coney Islanders have been feasting on this fruit. The pictures of the wreck will be shown in "Mutual Weekly, No. 96," released Thursday, October 29, through the company's exchanges.

WILL PRODUCE TWO NESTORS A WEEK

Al Christie, senior director in point of service of the Universal staff, who has not taken a vacation in six years, returned to the Coast last week after what he termed "a few minutes' vacation" in New York and vicinity. His sojourn was limited, because the distance across the continent is so great and the period at his disposal so short, most of his time was spent in traveling from the Pacific Coast to New York City and back to the scene of his duties.

However, not a day was lost on his arrival in the metropolis in seeing everything worth while and renewing acquaintances.

Mr. Christie has been in California three years, and during that time has produced two hundred pictures, writing the scenarios for all of the releases.

Two Nestor comedies a week will be produced beginning some time in December. Mr. Christie will have charge of the production of the first company, and the second company will be under the supervision of Eddie Lyons, who directed the Nestor studio during Al Christie's trip east. Later Mr. Christie will prepare a series of two-reel Nestors, for the production of which the first and second companies will be merged. These may be looked for around the first of the year.

DAYTON LOCAL ADDS NEW MEMBERS

Special to MOTION PICTURE NEWS

Dayton, O., Oct. 28.

Reorganization of the local branch of the Motion Picture Exhibitors' League was effected during the past week with the enrollment of a number of heretofore unresponsive exhibitors as members.

Resolutions were adopted by the reorganization committee providing for the appointment by the president of a committee of five, to be known as the service committee, consisting of one member for each regular service projected and two members for each feature service. The service committee is to act for all exhibitors in any differences with various film exchanges.

CONTRACT FOR WORLD FILMS

The Alfred Hamburger theatres, including the Zeigfeld, the large downtown Chicago house, are using Shubert and Brady features under a yearly contract that they entered into with the Chicago office of the World Film Corporation.

WOMEN ASK FOR A CENSOR

Some apparently well-intending ladies who are unfamiliar with the workings of censorship in other cities, have started a movement to secure a local censor at Lake Charles, La. This plan was taken up at a recent meeting of the Parents' Club of the fourth ward in that town and it was agreed to adopt definite plans at the next meeting.

Excelsior Will Screen "The Under Trail"

Author of "Eagle's Mate" Supplies Alliance Firm with Subject for Next Release—Favorite's Second a Racing Story

THE Excelsior Feature Film Company, Inc., at its studios in Lake Placid is now working on "The Under Trail," picturized from Anna Alice Chapin's book of the same name.

Miss Chapin is the author of "The Eagle's Mate" in which Mary Pickford scored a tremendous success.

"The Under Trail" is one of the prettiest romances ever written about the majestic Blue Ridge Mountains of Virginia, and with the splendid cast engaged by the Excelsior Company to interpret the characters of this story, it is safe to predict that "The Under Trail" will be one of the best productions made in some time. The picture will be released on the Alliance program.

"The Man Who Could Not Lose," the second release of the Favorite Players Film Company, is one of the most original race track story that has ever been presented.

It is a distinct novelty in many ways, as it has none of the ancient theatrical tricks so often resorted to in dealing with stories of this kind. Carlyle Blackwell, the former Famous Players' star, is playing the leading role and is supported by a great cast of screen favorites. This story is by Richard Harding Davis, and was adapted for the screen by Robert A. Dillon.

Winifred Allen, formerly of the Edison Company, has been engaged by the Excelsior Company to play a prominent part in the next production, "The Under Trail," by Anna Alice Chapin, author of "The Eagle's Mate."

Miss Allen has all the characteristics which made Mary Pickford famous, and she was selected for the part by William H. Wright, treasurer of the Excelsior Company, after he had interviewed over a hundred applicants who applied for the engagement.

Hoffman Takes Charge of Universal Exchanges

Former Special Representative of the Company in Middle West Made General Manager of New York Branches

THE local exchange world has been pleasantly surprised with the announcement of the appointment of M. H. Hoffman as general manager of the New York Universal exchanges.

Mr. Hoffman is a lawyer and a graduate of New York City College and New York University, and practiced his profession in New York and New England for ten years before entering the film business. While an attorney, he became interested in a circuit of theatres, and later W. E. Greene made him manager of his Springfield, Mass., film exchange.

When the Universal Film Manufacturing Company took over the Greene exchanges, Hoffman was made special representative for the Universal in the

Middle West, and then manager of the Twenty-third street, New York, exchange. All told, it took Mr. Hoffman four short years to accomplish what he is in the film business.

In his new duties, he will have the supervision of the Mecca and Twenty-third street exchanges of the Universal; at the former branch, he will be ably assisted by Emanuel H. Goldstein, and at the downtown branch, by Sam Zierler. Mr. Goldstein was long in charge of the Newark office of the Universal, where he is succeeded by Lee Gainsborg. In addition to the metropolitan offices, the exchanges in Newark, N. J.; New Haven, Conn., and Springfield, Mass., come under Mr. Hoffman's charge.

Pathé Sale Is Emphatically Denied

Officers of American Company and William Fox, Who, It Is Said, Had Bought the Studios, Put Quietus on Rumor

A THEATRICAL publication in a recent issue stated that Pathé had sold its American studios and that the Eclectic Film Company with its numerous exchanges was also for sale. The officers of the American Pathé Company are indignant that such a story should be published without any foundation whatsoever, and emphatically deny that any such move is contemplated.

It is presumed that the story arose from the fact that the Jersey City studio was recently rented to a producing company which desired to take advantage of its fine facilities in the making of a picture.

William Fox, president of The Box Office Attraction Company, states that

the report being circulated that he has purchased the Pathé studios and all of the Pathé interests in America is untrue. No such purchase was ever contemplated or even discussed.

"My relations with the Pathé Freres has always been quite pleasant and I would not like to have this relationship interrupted by a repetition of trade gossip," said Mr. Fox.

RETURNS TO PHOTOPLAYS

After a very brief experiment with other forms of amusement the Lafayette Theatre, New Orleans, has decided to return permanently to motion pictures. A. B. Seligman is in charge and is using the Mutual program.

Repairing a Theatre's Reputation

By John W. Hawkins

Job Had Nothing on Holway For Patience When It Came to Applying Home-Thrust Maxims to the Film Business—This Live Manager Adjusted His Programs to the Tastes of a Steady Cilentale After Worrying Out Their Preferences

“**M**AKE the public your friend. Convince your patrons that you are trying to give them all that you can for their money. Make them look up to you instead of down at you.

“Don't try to meet competition by doing the same things that the other fellow does. Do something different.

“Be original.

“Individuality is the life of trade, whether you are selling shoe-strings or theatre seats.”

THESE are some of the maxims of B. A. Holway, manager of Proctor's Broad Street Theatre, Elizabeth, N. J.

He doesn't say to himself for he doesn't believe in talking too much. He just listens and then coins the other fellow's ideas if they are worth coining.

But Holway believes that these principles are way signs on the road to success in the moving picture business and apparently he has picked the right road.

Before he took charge of the Broad Street Theatre, Holway was a newspaperman. He “broke into” the film game less than a year ago, but during his few months' experience he has learned more than many who have been at it for years.

His newspaper training taught him to observe things and this training has stood him in good stead. He knows his public although very few of the public know him. He stays in the background—and does things.

THE Broad Street Theatre is the largest house in the city devoted exclusively to the presentation of the motion pictures. It seats an audience of about 1,200 and has both orchestra and balcony seats.

It has no gallery. It was formerly a stock theatre. When Holway took hold of the house, it was just a theatre. People went into it when they had nowhere else to go and then, nine times out of ten—kicked themselves for going.

It had few regular patrons. Its exhibition policy was vacillating. Sometimes it showed one make of films and sometimes another. The people were not acquainted with the actors and as a result the audiences were the casual, drop-in kind with the “I'm-here-now-but-never-again” attitude which does not spell profit for any amusement enterprise.

There were always a few hoodlums, several drunks and a chorus of lusty-lunged infants to add to the enjoyment of performances.

Now all this is changed. The same faces are to be seen in the audiences at

the theatre every week, and among its patrons are some of the “best people” in town. They know that at the Broad Street Theatre they will see a clean, interesting show amid congenial surroundings.

THE theatre has been given a cozy, home-like atmosphere which means a whole lot in dollars and cents to the management. The improvement has been subtly made. How was it brought about?

When Holway took charge of the amusement house, it was enough to discourage Job. Always the front of the theatre was bedecked with lithographs, gaudy and glaring. There was nothing especially alluring about the lobby.

It was decorated with the framed photographs of motion picture actors about whom the audiences knew nothing and probably cared less. Even the ticket booth had a “come across” appearance that was flagrantly commercial and the man at the door made you feel that he was doing you a favor by letting you come into his theatre.

The air in the house was generally permeated with a garlic odor too keen to be enjoyable and the babies and hoodlums aforementioned did not tend to enhance the pleasure of the audiences.

AND the pictures! The management seemed to jump about from one exchange to another picking up a film here and there in a more or less haphazard fashion. There were never any feature pictures or really high class photo-productions. The pictures were just pictures—that was all—and you gained nothing from looking at them but weary eyes and that tired feeling.

The pictures were shown to the accompaniment of a piano. The player drummed most of the time and the effect was as unmusical as it was irritating.

The first thing that Holway did was to standardize his shows. He mapped out a regular program for the week and stuck to it.

At the present time he books one big feature a week and that is shown on Friday. Patrons of the Broad Street Theatre have been educated to the fact that Friday is feature day, and all they have to do to find out what the feature is, is to look in the Thursday or Friday evening's papers.

MONDAY is “Ford Sterling day.” Sterling is well-known now to Elizabeth theatre-goers and his name alone is enough to draw a full house. Of course, enough other films are shown to round out the bill for the day, but Sterling is the main attraction.

Keystone comedies, “The Mutual Girl”

series, “Mutual Weekly,” “Animated Weekly” and “Universal Ike” pictures are a few of the other attractions which are booked with regularity at the Broad Street Theatre.

The effect of this method is the same as in a stock theatre. The audiences get acquainted with the actors and the name of the actor acquires a greater drawing power than the title of the picture in which he appears.

Several Mary Pickford films have been shown and if Holway were to advertise tomorrow simply “Mary Pickford Here Today” there would be a hold-out at the theatre for all performances.

The faces of Charles Chaplin, Mabel Normand, Margarita Fischer, Florence Lawrence and other film stars are as familiar to patrons of Proctor's Broad Street Theatre as the countenances of their next-door neighbors.

BY his method of booking, Holway has secured for his theatre a big list of steady patrons, instead of mere transients. On certain nights you will see certain people at the Broad Street Theatre whether the weather is fair or stormy, and the effect of such a class of patronage is obvious.

By studying his audiences, Holway discovered the character of the pictures most popular with his patrons. He found that “meller-drammers” did not possess very great drawing power.

Photoplays of the wild and woolly west did not provoke any outbursts of enthusiasm and the exhibition of educational films did not cause any hold-outs.

So pictures under these classifications have been barred out. In their places have been substituted society dramas, lively comedies, and feature productions.

THIS change in the type of pictures presented not only built up a steady trade but it resulted in the attendance of a higher class of patrons. The people who “ate up” the thrillers, wild west pictures and others of their ilk stayed away and the house was better for their absence. The hoodlums, drunks, and garlic eaters keep away from the Broad Street Theatre now for its performances do not appeal to them.

Having adjusted his programs, Holway set about to improve the incidental features of the theatre. The old piano was relegated to the scrap heap and a new Wurlitzer orchestra was installed.

In the hands of a skillful player, this instrument produces music which adds to rather than detracts from the pleasure of the audiences. It used to be the piano player's custom to change his tune with each deviation in the action of the picture.

CUMMINGS JOINS ROLFE

B. A. Rolfe, of B. A. Rolfe Photo-plays, Inc., has engaged Irving Cummings for prominent roles, in a number of his forthcoming productions which are to be released through Alco.

Mr. Cummings was born in New York and prior to a course at Columbia was educated in the public schools. In 1901 he took up stock work at the Columbia Theatre in Washington. The following season he played the boy part in "David Harum" with William H. Crane, and



IRVING CUMMINGS

continued in this role for the second season. In 1905 he was playing in "Ben Hur." He was next promoted to juvenile leads and made his bow as a matinee idol to Indianapolis audiences in the English Stock Company.

The season of 1906 found him in "Way Down East." Then came two seasons in "The Man of the Hour," during which Mr. Cummings played Arnold Bennett, the young Mayor. Engagements in stock with the Sherman Brown Company, Milwaukee, and at the Belasco Theatre, Los Angeles, were next. The College Theatre, Chicago, which Father Malone conducts, claimed his service next. Then came engagements with Tyrone Powers in "The Servant in the House," and with Lillian Russell.

TWELVE HUNDRED EXTRA PEOPLE IN SCENE

In "The Man Who Could Not Lose" the Favorite Players Film Company has used twelve hundred supernumeraries on the stage and in the audience of a theatre hired in Los Angeles to take this scene.

"The Man Who Could Not Lose," by Richard Harding Davis, and adapted for the screen by Robert A. Dillon, promises to be an exceptional film, and the Favorite Players is determined to make this production one of the greatest race track stories ever produced.

It is scheduled for release on the Alliance program.

Philadelphia "Reel Fellows" Dicker for Club

Trying to Make Arrangements for Temporary Quarters Near Film District
—Ball in the Near Future—Permanent Home in Six Months

Special to MOTION PICTURE NEWS

Philadelphia, Oct. 28.

AFTER a lapse of about a month a special meeting of the "Reel Fellows" of Philadelphia was called for Sunday, October 18. The foregathering was held at the home of the Franz Schubert Bund, 1416 Arch street. The two most important matters considered were the holding of some form of entertainment in the near future and the securing of temporary quarters. To take care of and report back to the organization on ways and means a committee was appointed. They will obtain information as to the possibilities of various methods of raising money and a special meeting of the club will be called to act upon the various suggestions.

It is very probable that a large public ball will be the event decided upon as the first public affair. The committee appointed consists of Dave Keen, Pennsylvania Film Booking Agency; Dave Sablosky, exhibitor; Jay Emanuel, manager, Ridge Avenue Theatre; Steve Talbot, Billboard; and Simon Libros, Picture Playhouse Film Company.

The other and vital question was the selection of temporary quarters. Negotiations have been under way for the use of the Franz Schubert Bund clubhouse where the meeting was held. It was decided to make that the "Reel Fel-

lows'" home for the next six months if satisfactory arrangements could be made. This may be done by the admitting of the members of the film club to membership in the Bund. In that event the former would have the same privileges as the associate members of the latter. This will settle for the present the questions as to where an out of town visitor may be entertained and also the Sunday thirst problem, which has for a long time been very troublesome.

It is hoped that before the end of the allotted six months that sufficient funds will be in hand to purchase a building or to build one of their own. Stanley Mastbaum, one of the directors, and also connected with a local real estate firm, is looking for a suitable site and may even take care of the erection of a clubhouse until the club is able to reimburse him. One of the prominent manufacturers has signified his willingness to furnish the quarters when secured.

At the next meeting a vice-president and one director will be elected to serve in the place of two gentlemen who were unable to accept because of business affairs. The next meeting will probably be on Sunday, November 1, at which time the matter of using the Bund's house will be finally settled.

JULIAN M. SOLOMON, JR.

New Brunswick Authorities Hold Up Pictures

Military Authorities in St. John Object to Activities of Camera Men on Account of Strong War Feeling

Special to MOTION PICTURE NEWS

St. John, N. B., Oct. 21.

A MAN with a camera about St. John in these stirring times of war is a militia suspect as soon as he is seen, and when he attempts to "open fire" with the photo-machine his address and telephone number must be immediately given to the uniformed officers, while judging by the experiences of two visiting American motion picture men to the city last week, the camera is immediately placed "hors-de-combat."

R. H. Darrah, director, and Frank Waid, camera man, arrived in St. John for the purpose of taking pictures of the harbor front, the reversing falls, public works and city features. They came here to take certain views for a film to be entitled "Boston Harbor and Its Tourist Transportation to the Great Summer Resorts of the East."

In order to get their realistic views of St. John, Messrs. Darrah and Waid engaged a tug boat and sailed out on the placid waters of the harbor. Out from a neighboring wharf shot another tug boat, and quickly it bore down upon them. From its deck there stepped

aboard four uniformed officers of the militia, members of the force defending St. John from a possible attack. The picture men were told that they would have to procure official permission before they could take the pictures, the reason being that such a move was regarded with suspicion because of a possible benefit to the enemy being derived.

Reluctantly the camera was put away. Pictures had been taken of certain portions of the harbor front, showing the wharves, docks, elevators, etc., and in order to explain the innocence of their mission thoroughly, Messrs. Waid and Darrah allowed the negatives to be examined by a military board of inquiry. Their camera meanwhile had been placed in seizure by the officers.

It remained in custody for a couple of days, when through the influence of W. H. Golding, manager of the Imperial Theatre, it was temporarily released. An arrangement was then made whereby the whole affair was satisfactorily settled, but it was not without many exciting moments for the two picture men from the United States.

FRANK I. McCAFFERTY.

MAKING LOCAL FILMS NEAR THE EQUATOR

By Amando Cespedes Marin

A Costa Rican Live Wire, Self Taught in the Difficulties of Developing and Printing in a Locality Remote from Manufacturing Centres, Records His Own Experiences and Gives Detailed Instructions for Finishing Local Event Pictures—The Second Article

THERE are many styles of cameras in the market, but my purpose in this article is not to describe them nor to recommend any special one.

A reliable dealer in photo goods can show you what to get, but if you read last week's article, you would see how, with no knowledge of picture-making, I was able to do something with an amateur's camera.

You do not need a high-priced outfit; only intelligent effort.

Let us say, then, that you have bought a camera, either American or European make, preferably one that is not covered with leather, which often does not prevent warpage. That the mechanism is of the "claw" system, the movement used in most high-grade film cameras. It is simple and reliable, requiring no attention but a few drops of oil and careful cleaning afterwards.

Directions to Be Followed

Most all machines have complete instructions for manipulating them. Take an old piece of film, put it in the box and thread it according to the directions. Turn the handle until you accustom yourself to an even movement, which is the principal effect in any motion picture film.

Bear in mind the speed of the shutter, and have a Goerz, Zeiss, Ernon, or any double anastigmat motion picture lens. Each turn of the handle produces eight or nine small pictures.

The speed of the pictures depends upon the opening of the diaphragm in your lens, and not from the distance at which the pictures are taken. As the best work is done on a bright day, we will fix our lens with an opening of $b/11$, and thus, if we turn the handle a complete turn per second, the speed will be 120th part of a second per picture; if we give two turns of the handle per second, it will be one 240th part of a second to each picture; and if three turns, a 360th part of a second.

That speed must be given to prevent blurring the movement of the object, but for a common local view you may use a steady movement of a hundred turns of the handle per minute, which will undoubtedly give you well-exposed negatives, full of detail.

Not Necessary to Cover the Lens

You may expose as much as you want, making a stop without covering the lens, but remember that at each stop of the handle there will be about four inches of the film spot black, which will serve you as a guide for inserting the titles when you make the positive.

Therefore, make a memorandum of

the scenes you take and insert titles properly.

Each magazine will contain a roll of 200 feet film, the best size used. And the same will give you about a five-minute exhibition together with titles.

The dial will show you how many feet of film have been used so that when finishing the 200 feet you will spoil only a little piece. Four or six stops will be very convenient.

Something that you must bear in mind is the focus of your lens. The distances are marked on the lens' barrel from three or six feet up to infinity. Therefore, be careful to set the distance approximately; but when using a diaphragm as small as $f/16$, pretty near everything from 15 feet from the camera will be in focus.

Different Lens Focus

There are different lens focus; a two-inch or fifty-millimeter lens is a common wide angle lens, used for close pictures, like parades from the sidewalk of a street.

It takes more scenery from a distance, as a three-inch lens does from the same distance. The three-inch or 75-millimeter lens is used more for stage work groups, single persons, large heads, plants and film titles. An equipment with both size lenses is decidedly necessary, but the two-inch lens will do well for general work. I have been doing all kinds of work with that size lens and focus less camera.

Before manipulating the machine set the dial measure to zero.

When light is bad, open up to $f/9$ the diaphragm and turn the handle with the same speed.

I have taken pictures about 6:15 in the evening, turning the handle about one per second with $f/6$ with splendid results.

The opening in the shutter is also important, but set it for $1\frac{1}{4}$ -inch opening for regular work.

Taking Rainy Day Pictures

You can take pictures on a rainy day, using larger diaphragm, say $f/6$ or 9 , but I will advise you to start making pictures with $f/16$ on bright, sunshine days; they will get good results.

At any time use the sun shade cone fitted to the lens flange, as that will prevent reflection. Pictures can be taken against the sun if properly shaded and beautiful effects obtained, little known to the public.

Now, you must learn to use the panoramic tripod part, as it is very interesting and you can work it very easily at the same time you turn the handle

gently. Learn first and then soon enough you will secure splendid panoramic effects.

After the film is exposed, clean the aperture of the film window, the track and the pressure door, as small pieces of emulsion are likely to gather and scratch the film when running a new one. Then remove the film box and when at home you may proceed to develop the same.

Developing the Film

There are many concerns that finish the entire work for you, but developing is an easy matter.

Photography is based on the action of light upon silver salts. The action of light upon those salts is to turn them black in a greater or less degree. Those salts are coated upon the celluloid film spread over gelatine emulsion as a general principle.

When the exposure is made, colored white objects turn the emulsion dark, and dark objects which do not reflect white light, affect the emulsion little, if the subject and the length of time of any, in accordance with the color of the exposure.

The effects, if any, can not be seen on the new film at all, but when developing same, under a chemical action.

Thus, we need a developing outfit either home-made like the one mentioned in the first part of my article, or ready bought from a manufacturer.

There are many outfits on the market which you can buy in New York or Chicago. What you need is the following:

One developing tray or tank; one wetting tank, that can be used for staining the film in any color; one fixing tank, and one washing tank.

Either Tank or Tray

As mentioned, they can be either tank or tray. The difference is that with a tank you dip your frames in and the work is easily done; and with the tray you must handle the rack films a little more carefully. The trays can be square or round.

You need also a winding stand or a rewinder. And if needing the work quickly you must have a drying drum to hold of course at least two hundred feet of film.

The solutions needed for developing are the following, which obtain the best results:

Developer: Adurol, for 1,000 ounces; water, 660 ounces; sodium sulphite, twenty-one ounces, and sodium carbonate, thirty-two ounces.

Dissolve those chemicals in the order

given and when dissolved add six ounces of Adurol Hauff (German make).

The developing must be watched closely with a watch in hand, but it is almost a mechanical one if properly executed.

For the fixing solution: Hypo, for 1,000 ounces; water, 700 ounces; hypo, 10 pounds. Dissolve by continuous revolving the chemicals within the tank. Add 105 ounces of water, 1½ ounces bisulphite and ½-ounce citric acid.

The bisulphite and citric acids act as a clearing and hardening solution and also as a preserver for the hypo, which can be used repeatedly until exhausted. I mean until it is a weak solution and not until it disappears.

Preparations for Developing

Buy a red electric bulb specially made for photographic work, and install it in the room by merely attaching it to the socket lamp.

Fill the wetting tank with clean water. Have your winding stand or rewriter; wind on your film, by attaching the end of same to the frame with a tack if on a frame, or with the pressure hinges if on the rack.

Revolve the same around so that it covers the frame without overlapping each side, tightening the film a little, and when the frame is filled, cut the film at the end and put on another tack or pressure hinge.

Thus, we are ready to develop. Though you must bear in mind that all this work is done with the door closed and with only the red light, for white light spoils the film entirely.

Dip the frame in the wetting tank, moving same for a minute. Drop the water before dipping the frame into the developer tank. Then put the frame into the developer (Adurol solution) and you will move the frame up and down, but always covering the whole frame with the solution.

It is not necessary to move the same frequently, but about six times per minute. The images will appear in from 15 to 20 seconds and all will be completely developed in four or five minutes.

Recommends Adurol

I recommend Adurol, because it is a good keeping solution, stainless, giving stronger density than others with all details without being a rapid acting developer; and the used developer can be used and used over and over again. I have used the said solution with four thousand feet of film, negative and positive, which is cheap enough.

After the four or five minutes' developing, wash off the surplus developer by immersing the frame into the wetting solution and then proceed to immerse the frame into the fixing solution, moving the frame for thirty seconds up and down. Leave the frame there for fifteen or twenty minutes.

After twenty minutes the frame can be taken out to any white light, and dipped into the washing tank, which is filled with water from any supply.

The washing of films does not require a given time, unless you want to keep the negative stainless, but for quick work I always wash my films between fifteen and thirty minutes, and let them dry in a draughtless room, or wind them on a drying drum which will continuously revolve either by hand or by electric motor.

I have a home-made drum with a twenty-four-inch diameter cylinder made with thirty-five wooden moulding in six feet lengths, to which I attached a twenty-inch round moulding pulley, a machine round belt and a common sewing machine electric motor, which gives my drum a continuous movement of one hundred turns per minute. With a drum like that the film is dried in about one hour or two.

Avoid All Dust

Be careful of dust, as same injures the films badly.

After drying, loosen the film from the frame, rack or drum and wind the film with the gelatine side in.

Clean with a cloth the celluloid part of the film, the brilliant part.

Assort all pieces of film by uniting them carefully and cutting out any bad or spoiled parts, taking care when patching same to leave a stub on the end of the film; just cut exactly on the line on the second film holes, leaving thus a hole after the dividing line of the picture.

The other end must be cut exactly in the line of the dividing picture. Scrape every part of the end film and it is easy done by wetting that little part and scraping the same with your finger-nail covered with a soft handkerchief. The emulsion will be off, leaving the clear celluloid; then apply with your own finger a little of film cement to that part of the celluloid on the side of the gelatine, and also apply it to the celluloid side of the film that you desire to patch.

By bringing them together, so that the holes of the films correspond exactly, and by pressing carefully for a few seconds both films patched, the celluloid will be united.

Many Styles of Film Menders

There are on the markets several styles of film menders, which will help out easily such operation. Film cement can be bought from any dealer, but if you fail to get same, it is easy to be made. A piece of film of celluloid, five inches long, dissolved in one ounce of acetone, is a satisfactory cement for common celluloid films, but for non-inflammable films one ounce of acetic ether, one ounce of acetone merch and one emulsion less non-inflammable film cut in fine strips, it will work fine for either film stock.

When all is assorted, the negative film is ready for printing.

Get from your dealer positive film stock, any kind; Eastman, Afga, Lumiere and so forth. All films come within dark wrapped paper in tin boxes. Handling of the film is the same as with the negative stock, with the exception

that the silver emulsion is not so sensitive.

If the printing is to be done by the same camera, load the positive in just the same way as if it were a negative and thread the same likewise into the other film dark box. Have your negative on the special fixture on top of the camera; pass it through the slit direct over the track and through the slit underneath the camera.

Watch that the film picture window corresponds with the picture itself by turning the handle previously set to the slow crank axle, and see that when the shutter is open in front of the film window, the picture is entirely correct and does not show the dividing line of next picture.

Closing the Entire Camera Door

Thus done, the printing will take place by closing the film door holding both the negative and the positive, and closing the entire camera door to prevent the positive from being struck by light.

The lens door must be opened completely to let the light shine on the shutter mechanism, and the shutter itself all opened, thus it will leave one-third opened and two-thirds closed, before the film window.

Any way, follow the instructions enclosed for the camera manipulation.

When all is ready, get a fifty-candle-power incandescent bulb, and set same about six inches from the camera window for a little dense negative, but for a clear, sharp detail looking negative, a distance of ten inches is good enough.

Have a basket underneath the camera tripod to receive the negative, which naturally shall wind out from the camera, and begin to print by turning the handle of the machine step by step, making about one hundred pictures per minute, or in other words, one hundred turns per minute, as the lower crank gives one turn per picture while the motion picture crank does eight or nine pictures per turn.

Developing with the Same Solution

When all is printed, rewind the negative and take out the filled positive film box and proceed to develop same, with the same solutions and with the same time as for developing the negative film.

Do not be afraid of doing exactly as I have written, and you will have fine positive films from your negative.

After having washed the positives, you may tint same, or tint some parts of them as your taste desires by using aniline colors suitable for film staining, and remembering that with two ounces you can make one gallon of tint solution.

Do not tint your films on the same developing frames, but use special frames for that as well as special tank, and dry them on the frame and not on the drum. Those manipulations will help to stain your next batch of films.

You can mix ten ounces of glycerine with each 1,000 ounces of tinting solu-

(Continued on page 50.)

LIVE WIRE EXHIBITORS

EDITOR'S NOTE.—It is the desire of "The Motion Picture News" to include under this heading novel advertising ideas, successful schemes in the management, decoration and equipment of the theatre—everything, in fact, done by the exhibitor to stimulate his trade. We invite every exhibitor to write us about any new enterprise he has; also to come to us for advice or information along any line. Address: Editor, "The Motion Picture News," 220 West Forty-second Street, New York City

LIVING DOWN A NAME

MANAGER W. W. DUNLAP of Clune's Exclusive, Los Angeles, formerly for women and children, and men admitted only when in company with women, finds the name of the theatre to be a hoodoo since the exclusive feature has been discontinued. Beginning Monday October 5, all the newspapers will carry one-inch advertisements containing this copy "547 Broadway." Simultaneously with these ads. will appear a big electric sign reaching across the front of the theatre building bearing the same, and replacing the sign "Exclusive."

Mr. and Mrs. Al. Katzenburger, trap drummer and pianist, who have been featured on practically every vaudeville circuit of the West, are now playing the pictures at this theatre, and many comments, that the house reminds one of Chicago theatres, have been heard.

"LIGHTING" HIS HOUSE WITH STARS

MANAGER SETH D. PERKINS, of Los Angeles, recently arranged with Harry McCoy, juvenile lead and comedian at Keystone studio, to act as pianist at the Optic Theatre Monday of a certain week, Mr. McCoy to play only his own compositions. Tuesday Director Eddie Dillon and Tammany Young, lead of the Mutual Komic brand, agreed to take tickets. Wednesday Miss Fay Tincher, comedienne of the Komic brand company, acted as ticket seller. Mr. Perkins expected this array of talent on the outside, coupled with his program, principally of comedy, to bring record business. And it did!

PICTURE OF THEATRE EFFECTIVE ADVERTISEMENT

MANAGER J. A. BERNOWER, of the Alhambra Theatre in Canton, O., has introduced a form of newspaper advertising that is producing satisfying results for his house.

At the top of his advertisement each day he prints a zinc etching picture of the front of his theatre. The picture makes his advertisement stand out, and an appreciable increase of patronage during the past summer was traced absolutely to this particular advertising "stunt" of Bernower.

PUTTING IT ACROSS WITH ADVERTISING

IT may be that "The Trey o' Hearts" received more than its share of publicity in Fairmont, Minn., but it is the theory of the manager of the Haynic Theatre that the way to launch a serial story is to smear the bulk of the advertising money in advance. The serial was opened to remarkably good business and the management feels satisfied with the campaign.

The story was run on Tuesdays in the local daily paper and the pictures were shown on Friday. Buttons were also shown which were considered the best advertising got out for the picture; and the theatre pasted a lot of billboard paper.

The price was raised to fifteen cents when "The Perils of Pauline" opened. A four-reel regular service was used, and it was a case of either run six reels at an increased price or ditch two reels.

The former course was adopted and the theatre had a fifteen-cent program once in two weeks. Shortly thereafter "Lucille Love" was started on the same plan. A fine business with both of these

serials was done at that price, and the only objection heard was that the admission price was so uncertain that nobody could tell in advance what he would have to pay. That defect was remedied by jumping the show to six reels and charging fifteen cents all the time.

The results have been more than satisfactory. More people are seeing the pictures now than ever before. Of course, the management is putting up a good show for the money. It is playing the "open market" a good deal and buying the best pictures that can be found. The film bills are high, judged by the standards of the ordinary country town, but the manager thinks that the public is willing to pay for good service.

"FALL OPENING" FOR THEATRE

THE annual autumn fashion show in Los Angeles gave Manager Harry Nogle, of Clune's Broadway theatre, an inspiration. The fall opening proved a



THE CLIMAX OF "THE HOPELESS GAME" (Lubin—Two Reels—October 21)

big drawing card for the merchants, he discovered, and he came to the conclusion that it would be a good thing for the Broadway.

In three days he had the front of the theatre changed—floral decorations were added; the interior of the house was brightened up in several ways; a new and larger orchestra was secured, and then he advertised:

**Fall Opening
of
CLUNE'S BROADWAY
Everything New**

Below was given the features of the program, a mention of the new soprano and the big orchestra. To use the expression of the owner, "It was just like opening a new house." The business for the first two days tripled the corresponding days of the previous week.

**NEW PROJECTION MACHINES HAVE
GOOD EFFECT ON PATRONAGE**

MANAGER JOSEPH WEIDMAN, of the Central and Broadway theatres, Albany, N. Y., is fitting his theatres with new machines. The Broadway was recently treated to two of the best makes, and the patrons were delighted when the pictures were shown clearer and brighter than ever.

Mr. Weidman is thinking seriously of making the Broadway house a ten-cent affair; that is, to charge that admission every night in the week. As the Broadway is situated near the Union Station, and thereby gets a big transient trade it is believed the new scheme would be a success.

**DRUG STORE LOBBY FRAME
CATCHES EVERYBODY**

MANAGER WRIGHT, of the Clinton Square Theatre, Albany, N. Y., has stolen a march on his many competitors by placing a show board in the lobby of one of Albany's largest drug stores.

This store being in the shopping district, the board is seen by thousands every day, and has done much to boost the Clinton's business.

"FOR SWEET CHARITY'S SAKE"

CHILDREN from all the Syracuse, N. Y., charitable institutions will be admitted without charge hereafter to the Regent Theatre, on the first two Saturdays of each month. The new house is enjoying an enormous patronage, and the presentation of pictures that children can be taken to with impunity has been one of the big aims of the management.

**HAMILTON PREMIUM WITH FIVE
CENT TICKET**

THE Lyceum Theatre has announced that every Wednesday it will give one Hamilton premium coupon with every five-cent admission. This is the first house in Syracuse, N. Y., to try this method as a business booster.

Washington Ball Will Make Film History

Auto Sight-Seeing, Banquet for Screen Favorites and Celluloid Record of Event Will Make Occasion a Red-Letter Day

Special to MOTION PICTURE NEWS

Washington, D. C., Oct. 28.

THE thought uppermost in motion picture circles in the Capital City at present is the ball and reception under the auspices of the local Motion Picture Exhibitors' League and the Washington "Post," to take place on Hallowe'en night, at Convention Hall. All arrangements have been completed for this event, which promises to be a reel novelty in Washington.

At least fifty players from various eastern studios will be in the hall to meet and dance with their large circle of admirers here. Arrangements have been made to bring the photoplayers in two special Pullmans from New York on the Congressional Limited Saturday afternoon.

Those from Philadelphia will join the party at that city. A special committee will meet the train at the Union Station and hurry the guests in autos to the Raleigh Hotel and later escort them to the ball room. By popular demand, the Essanay Company have permitted Francis X. Bushman to come all the way from Chicago to greet his host of Washington admirers.

The Convention Hall is being turned into a tented garden by drapers and florists. Two orchestras of twenty-five men will furnish continuous music for

the dancing, which will begin early. As soon as the players arrive the floor will be cleared and the photo stars will circle the room in a grand march, led by screen favorites. The reception to the players will continue throughout the entire evening, and many of them will mingle with the public in dancing. Some special features will also be served.

At the close of the dance the players will be the guests of the Motion Picture League at a banquet at Harvey's, where an elaborate menu will be served. The arrangement of the menu promises to savor of the screen and some surprises have been arranged for the event. It is planned to take a motion picture of Convention Hall when the ball is at its height, and this will be exhibited in the local theatres.

The various committees who are making this event a success are as follows:

Publicity: Fulton Brylawski, Harry Crandall and Wm. P. Herbst.

Program: V. H. Stoneseiffer, R. H. Campbell, and T. H. Eastwood.

Music: J. Morgan, Julian Brylawski, and Noris Davis.

Decoration: Ira LaMott, Alan Bachrach, Ned Stein, and H. S. Wolf.

Reception: The entire local Motion Picture Exhibitors' League.

THEODORE FRANKLIN.

WHERE ADVERTISING IS NEEDED

IS the motion picture business on the wane in Albany, N. Y.? This is a question that is being asked by the film enthusiasts of the city on account of the decline in business. It is not meant to say that any of the theatres are on their last legs, for they are not, but the business has fallen off greatly since last year.

The smaller houses are all kicking over the state of affairs, and are trying to find a way to boost matters along. One trouble with the little fellows is that the larger houses are showing six and eight reels for the same price the smaller affairs are giving four reels.

Proctor's, Leland, the Colonial, the Orpheum, the Hudson and the Clinton Square are doing good business, still, even at these places, the patronage is not as large as it was a few months ago. These theatres all advertise, and do so extensively, and they "have it" on their smaller competitors in this respect, who cannot afford to put money in the newspapers.

There are less expensive schemes of advertising than the newspapers, and these small theatres should get busy on some of them. The owners are of the opinion that all they've got to do is to put out a board in front of the theatre and the business will flock to them.

In this they are wrong, for it is always the show houses that let the people know, in some way, what they have

got to offer that are successful. Some are talking of trying schemes, but that's all there is to it. Now is the time to get into action, as the season is really just beginning. It is almost certain that if some of the managers don't get stirred into action soon, there will be fewer movie theatres in Albany in a month or two.

ELECTRIC SIGN ON ROOF

ALIVE-WIRE stunt in advertising has been started by Harold Edell, manager of the Strand Theatre, Buffalo, N. Y. He has just signed contracts for a second large electric sign atop one of the largest office buildings in Buffalo.

The one on Shelton square is already in working order and it is upon this sign that the weekly attractions are flashed nightly in thousands of incandescent bulbs.

**BENEFIT NIGHT FOR REVOLUTION-
ARY SOCIETY**

TO aid the Daughters of the American Revolution in his city, Manager Bulger, of the Lyric motion picture theatre, of Greenville, Ill., put on a benefit night for the society recently. He arranged a special patriotic program, heading it with the three reel Edison play, "The Southerners." The benefit drew out a big crowd and increased the popularity of the Lyric Theatre

The Exhibitors' Forum

MOTION PICTURE NEWS assumes no responsibility for any opinion or assertion made in the columns below, nor does the publication of a letter mean that the statements it contains are endorsed by the NEWS. All letters must be signed. No attention will be paid to anonymous communications.

Cleveland Exhibitors Protest Against Neff and Censors

Cleveland, O., Oct. 23.

Editor, MOTION PICTURE NEWS,

New York City.

Dear Sir: This is to advise that the following resolution was this date passed by the Cleveland Local, No. 1, of the Motion Picture Exhibitors' League of America:

Whereas, it has been announced that a trade journal in behalf of the motion picture business has been proposed and is about to be launched by Mr. Neff, Mr. Kohl, Mr. Vestal and Mr. Wilson;

Be it resolved, that we absolutely condemn the attempt of anyone using their office with or without intent to take advantage of their official position for the purpose of aiding their private enterprises.

Be it further resolved, that if Mr. Vestal and Mr. Wilson propose to publish such a journal that they immediately resign from the censor board, and Mr. Neff resign from the state presidency of the League and Mr. Kohl as national vice-president of Ohio.

Be it further resolved, that a copy of this resolution be sent to trade journals and all interested parties.

Yours very truly,

W. H. HORSEY,
Secretary.

M. P. E. L. OF AMERICA,
CLEVELAND LOCAL, No. 1.

ate, but will nevertheless be an enormous saving to the motion picture exhibitors throughout the United States.

I wish to thank MOTION PICTURE NEWS for the stand taken by them and the support given our efforts for the reduction of the oppressive tax as contained in the House bill. I have, as you know, been subjected to no little criticism for the graded scale which I proposed, and which has been substantially adopted, for the reason that certain exhibitors and associations thought even this tax too high.

Personally, of course, I should have been very glad to have had the tax reduced to a minimum or even altogether abolished, but both of these were impossible of accomplishment.

The graded tax which I succeeded in having adopted was not hastily considered by me despite the very brief time in which I had to prepare same, but was the result of very careful consideration and deliberations with a great many members of the United States Senate, particularly the members of the Senate Finance Committee which had the matter in charge, as being the only substitute which we had a chance of having adopted. I believe that insistence on anything materially less would have resulted in a total defeat of our efforts.

I hope that in the future matters affecting the interests of exhibitors in general throughout the country may receive their united and not their divided support.

Very sincerely yours,

FULTON BRYLAWSKI.

Brylawski Thanks the News

THE MOTION PICTURE EXHIBITORS' LEAGUE OF THE DISTRICT OF COLUMBIA.

Washington, D. C., Oct. 22.

Editor, MOTION PICTURE NEWS,

New York City.

Dear Sir:—I beg to inform you that the House and Senate have passed the war tax bill relating to theatres after changing the scale as passed by the Senate slightly, so that the new scale is as follows:

Theatres with a seating capacity of 250 or less, \$25; more than 250 and less than 500, \$50; more than 500 and less than 800, \$75; over 800, \$100.

Of course this is a little more oppressive than the scale adopted by the Sen-

Arouse the Public Against Censorship

MAJESTIC-RELIANCE STUDIOS

Scenario Bureau

4500 Sunset Boulevard

Los Angeles, Cal., Oct. 17.

Editor, MOTION PICTURE NEWS,
New York City.

Dear Sir:—It has occurred to me that one very effective way to bring the question of censorship directly to the attention of the public would be through the use of properly worded slides in theatres. It is difficult to believe that if the people were made sufficiently acquainted with the true conditions, they would continue in their present

passive approval of censorship as it is practised in many cities and states. No policy of censorship can long exist in any American community in the face of strong public disapproval.

As evidence that the American public is in a mood to assert opposition to censorship if given incentive and opportunity, permit me to cite the results that followed the projection on the screen of two paragraphs used as preliminary leaders or sub-titles in connection with "The Avenging Conscience," when that picture was exhibited in Pasadena and Los Angeles. The two paragraphs written by Mr. Griffith were as follows:

"A PLEA FOR THE ART OF THE MOTION PICTURE.

"We do not fear censorship, for we have no wish to offend with indecencies or obscenities, but we do demand, as a right, the liberty to show the dark side of wrong, that we may illuminate the bright side of virtue—the same liberty that is conceded to the art of the written word—that art to which we owe the Bible and the works of Shakespeare.

"A great divine is quoted as saying that from childhood his one besetting sin was brutality, but that witnessing the play of 'Oliver Twist,' with its scenes of savage ferocity between Bill and Nancy Sikes, did more to arouse within himself an abhorrence of brutality than all the lessons and sermons otherwise of his entire life."

When these paragraphs were flashed on the screen in Pasadena the spectators broke into applause, and again in Los Angeles, where the picture ran for a week, the applause was repeated at several of the exhibitions. On two of these occasions I was present and noted particularly that the applause was vigorous and distributed over the entire house of nearly 3,000 spectators.

Why would it not be practicable for MOTION PICTURE NEWS to have suitable argumentative slides prepared and furnished to motion picture theatres, to be projected at each show? It appears that an appeal to the public is the only resort left to the motion picture interests, and this plan followed up with vigor could hardly fail to bring forth results in all cities and states where censorship has become a menace to the photodrama.

Yours very truly,

FRANK E. WOODS.

PHILLIPS PICTURE CONTEST UNIQUE PUBLICITY PLAN

It seems certain that no one thing in motion picture advertising has attracted so much interest among exhibitors in and around New York for some time as the Coles Phillips picture contest. It is new, good, and unquestionably an example of the highest grade advertising ever attempted in the theatrical sphere. Moreover, it is not expensive or troublesome.

Mr. Phillips' art work is well known and ardently admired by the great bulk of the American people; and this, along with the cleverness of the scheme, and the success it is meeting with, are honest reflections of the experience and ability of the men who make up the Coles Phillips Company.

They are really doing something for the motion picture business; and in justice to every exhibitor, as well as to the company, it is only fair to say that the proposition is worthy of attention. It is the kind of thing that appeals to almost every man, woman and child.

The outline or the proposition can only be outlined briefly here. The company furnishes the exhibitor with a series of twenty different kinds of six-color pictures of twenty prominent motion picture actors and actresses.

These are made by the finest method of off-set lithography, and are suitable for framing. Exhibitors give them to their patrons entirely free through a period of twenty weeks, at the end of which the company distributes numerous cash prizes to the people who have collected the greatest number of the pictures. Other attractive advertising is furnished in connection with the contest

FAMOUS PLAYERS SECURE "ESMERALDA"

For some time past the Famous Players Film Company has been receiving requests from exhibitors and the public to star Mary Pickford in a film version of the celebrated play "Esmeralda." In order to comply with these numerous petitions Famous Players has now secured this favorite drama by Frances Hodgson Burnett and William H. Gillette, in which Miss Pickford will be presented within the next few months.

Miss Pickford's mastery of the art of blending comedy and pathos will have full sway in the role of Esmeralda, the little country girl who suddenly becomes an heiress, and is torn away from home and her farmer lover by an ambitious and mercenary mother, forced to learn the stilted conventions of the ultra-smart society she abhors, and betrothed to a titled fortune-hunter she detests, but who at last rebels and flies back to the brave heart that has been faithful to her.

"Esmeralda" is one of the most notable successes that ever came from the pen of its gifted author, and its charm and appeal should be continued and even increased in the motion picture production.

Lasky Party Leaves for Coast in Private Car

Eighteen Persons, Including President of Company, Who Intends to Remain Four Weeks at California Studio, Start Across Continent.

ONE of the largest motion picture parties to leave for the coast at one time left the Pennsylvania station recently in charge of Jesse L. Lasky, president of the Lasky Feature Play Company.

The private car Phillipino was engaged by General Manager Goldfish, of the Lasky company, and eighteen persons for a through trip to Los Angeles.

Jesse L. Lasky, head of the company, intends to remain at the Lasky studios

other Klaw and Erlanger-Joseph Brooks' productions, was with the travelers and will make her first screen appearance in "The Goose Girl."

Dustin Farnum, an exclusive Lasky star, will travel as far as Chicago with the Lasky party, when he will divert to one of the Southern roads for New Orleans where he will join Oscar Apfel, who is now there. Farnum will pose for a few Mississippi River scenes, essential to the Lasky-Liebler production

SOME OF THE LASKY TRANSCONTINENTAL PARTY



Top Row: Winifred Kingston, Jesse L. Lasky, Marguerite Clark.
Bottom Row: Frederick Thomson, Dustin Farnum, Edith Taliaferro.

for four weeks to watch and aid in the enlarging of the producing facilities and the staging of Harold MacGrath's "The Goose Girl," which will be an early release of that firm.

Another director, a member of the trans-continental party, to join the Lasky staff is Frederick Thompson, the former Vitagraph and Famous Players' director, who will immediately upon arrival at Hollywood begin work on "Merely Mary Ann," in which Marguerite Clark will play the leading role.

During Mr. Thompson's connections with the Famous Players Film Company he produced the "Sign of the Cross" and "The Spitfire," and while with Vitagraph was responsible for many of the better features created by that concern.

Edith Taliaferro, the dainty younger member of the famous Taliaferro sisters, well remembered for their work in "Polly of the Circus," "Young Wisdom," "Springtime," "Rebecca of Sunnybrook Farm," "Tipping the Winner," and

of "Cameo Kirby" which Farnum played in during its stage vogue.

Winifred Kingston, seen in "The Squaw Man," "Brewster's Millions," "The Only Son," "The Call of the North," "The Virginian" and several other Lasky productions, goes to New Orleans with Farnum and a cameraman. Miss Kingston will play the leading female role opposite Farnum in "Cameo Kirby." From New Orleans Farnum, Apfel, the cameraman and Miss Kingston will journey to Los Angeles on the Southern Pacific.

Marguerite Clark, who appears with the Lasky company by reason of an arrangement with Adolph Zukor, president of the Famous Players Film Company, accompanied by her sister, is a member of the private car personnel and will begin work on "Merely Mary Ann" just as soon as she arrives at Hollywood.

In addition to the stars and Mr. Lasky, the party contains two wardrobe women, a designer of costumes and two expert "period" seamstresses.

Looking Ahead With The Producers

FAMOUS PLAYERS SECURES RIGHTS TO "THE OLD HOMESTEAD"

ONE of the most notable acquisitions of stage successes yet secured for the screen is Denman Thompson's great rural drama, "The Old Homestead," the film rights of which have just been obtained by the Famous Players.

The Famous Players are now making preparations to produce the film version of this celebrated play in the old New Hampshire village which suggested the drama to its author, and to use the very house that is featured in the title.

It is estimated that over twenty million people have laughed and cried over "The Old Homestead" in the United States and Canada alone.

The Famous Players executed the transaction for the motion picture rights with Frank Thompson, son and heir of Denman Thompson, through the agency of Clarkson P. Ryttenberg. For many years Mr. Thompson refused absolutely to consider motion picture propositions for his father's great success, though he received frequent and flattering offers for the work, and his assignment of the film rights of the play to the Famous Players again indicates the esteem with which that concern is held in literary and dramatic circles.

The film production of "The Old Homestead" will forever immortalize this splendid dramatic conception, and the Famous Players film version will undoubtedly uphold the highest traditions of that concern.

Beauty Parlor Transforms "Country Mouse"

ADELE FARRINGTON makes her bow to the screen public in "The Country Mouse," a four-part serio-comedy written especially for her by Hobart Bosworth. The story is cleverly

in the world. A few days later they attend a political rally, at which a lobbyist, George Marshall (Marshall Stedman), defends the railroad.

Billy answers him vigorously, and Ad-

THE RURAL HOUSEWIFE BECOMES A BROADWAY BELLE



ADELE FARRINGTON BEFORE AND AFTER THE BEAUTY PARLOR SCENE IN "THE COUNTRY MOUSE"

(Bosworth-Paramount Feature)

worked out and the very human little touches of her acting will make a hit with any audience.

When Billy Balderson (Hobart Bosworth) and two of the cronies discuss the high-handed ways in which the railroad treats the farmer, dowdy, little Addie (Adele Farrington), Billy's wife, thinks her husband the most wonderful orator

die is overwhelmed. On the crest of enthusiasm, Billy is nominated for the Legislature, and later elected. Quiet little Addie feels that her cup of happiness is running over. But with their arrival at the State capital, a new era begins.

Addie is awkward and shy in her old, country clothes, while Billy easily adapts himself to the new conditions, and unconsciously neglects her for the company of Marshall and his beautiful wife, Myrtle (Myrtle Stedman), who are lobbying for the railroad. After several unhappy experiences, Addie wakes up, and calls in the services of Mme. Pauline (Rhea Haines), proprietor of a beauty parlor.

The result is so astoundingly transforming that Addie cannot believe her eyes; and Billy is fairly speechless with surprise when she suddenly appears at a brilliant reception. Marshall is distinctly impressed, too, and so ardently seizes the opportunity of persuading Addie to influence Billy's vote on the railroad bill, that Billy is furiously jealous, and demands an explanation.

He gets it, greatly to his discomfiture. All ends happily, however, and the spectator takes leave of this very human and delightful couple as Billy is humbly asking his little country mouse to teach him the tango! He learns its mysteries and other things as well.

The picture will be released through program of the Paramount Pictures Corporation on November 23.



SCENE FROM "THE STRAIGHT ROAD" (Famous Players-Paramount—Nov. 12)

FAMOUS PLAYERS WILL RELEASE "THE STRAIGHT ROAD"

"The Straight Road," conceded to be one of the best dramas of the late Clyde Fitch, is to be introduced to the motion picture public through the Famous Players four-part production, released November 12. In the film version, Gladys Hanson, one of America's most talented young leading women, admirably portrays Mill O'Hara, the girl of the slums, who rises above her environment to make one of the most tremendous sacrifices of which the heart of woman is capable.

"The Straight Road" is the drama of a submerged soul's conflict and triumph. Clyde Fitch knew the city and its various strata, and in "The Straight Road" he supplied a play that does not alone show the city's pavements, but penetrates far beneath the surface, into the hidden soul of New York.

Gladys Hanson is supported by a capable cast who suggest the original characters with commendable fidelity, including William Russell, Iva Shephard, Arthur Hoops and Lorraine Huling.

PAUL PANZER AN "EXEMPT"

Paul Panzer, who spills looks of hatred and deeds of villainy all through the "Perils of Pauline" was telling the other day the reason why he is not fighting for Germany in the present war. It will be remembered that Mr. Panzer, though he has been in this country for twelve years and is thoroughly Americanized, is a lieutenant in the German artillery reserve.

When the war broke out the popular "villain" went to the German consul-general's office and asked for advice. He explained that his two brothers were in service under the Crown Prince Rupprecht of Wuerttemberg as lieutenants of artillery and that he is the sole support of his aged mother and his wife and child. In view of this he was made exempt from the necessity of answering the call, it is said. The German consul-general has thus saved "poor Pauline" from an untimely and premature death.

HILL THEATRICAL DIRECTORY AN AUTHORITY

The Gus Hill National Theatrical Directory is the latest addition to motion picture trade literature which should be in the exhibitor's business library, as well as in the hands of exchange men, state rights buyers and producers.

The feature of the 1914-15 edition of the work, which supersedes the Cahn Theatrical Guide, is a comprehensive list of the leading motion picture theatres of the country. But even the information to be found in the legitimate and vaudeville sections of the work, is of direct or indirect importance to anyone in any branch of the amusement field.

About one hundred of the book's six hundred and eighty odd pages are devoted to motion picture theatres, exchanges and cognate information.

"Rip Van Winkle" Revived in Alco Release

Jefferson "Legitimate" Favorite, Considered Dead Speculation by Boucicault, Who Wanted Cash Instead of Royalties, Will Please on Screen

IN view of the release by Alco Film Corporation on November 9 of "Rip Van Winkle," which is the production of B. A. Rolfe Photo Plays, Inc., the history of the original play, "Rip Van Winkle" is most interesting.

Thomas Jefferson is playing the part of Rip in the Rolfe picturization, but, of course, as everyone knows, Joseph Jefferson, father of Thomas, was the creator of the part. Joseph Jefferson was more than that: He was, indeed, part author of the play. Although his grandfather had played a "Rip Van Winkle" version, Joseph was the first to have a play written along the lines so familiar

bers of the family have given more than 1,600 performances. Now 'Rip Van Winkle' in picture form is to visit every large city in the world, and in time every village and hamlet."

In "Rip Van Winkle," as presented by Joseph Jefferson, there was always reference to "My poor dog, Schneider." The elder Jefferson spoke constantly of his love for Schneider, and also of Schneider's thieving qualities, the intimation being that Schneider was a great aid and comfort to Rip. But Joseph Jefferson introduced into Rip Van Winkle no live dog.

In the Alco release of November 9



"WOULD YOU TURN ME OUT LIKE A DOG?"
(Scene from "Rip Van Winkle"—Alco Feature)

to the last generation. He disregarded the version of Joseph Jefferson, the third, and took Washington Irving's "Sketch Book" to Dion Boucicault. Joseph Jefferson showed Boucicault what he had written and wanted Boucicault to elaborate on the same lines.

"Great Scott, man," exclaimed Boucicault, "do you think the public would stand for a man sleeping twenty years?"

There was a long argument over the advisability of the thing. Boucicault refused absolutely to put any faith in it. After it was settled that Boucicault was to write the play, Jefferson asked if Boucicault wanted a royalty or cash.

"Give me cash; I want no royalty; I want my money quick; because it is the last I will ever see from Rip Van Winkle. It won't earn a cent of royalty," he said.

So Joseph Jefferson paid \$5,000 cash to Boucicault for his rights in the play which he was to fashion.

Thomas Jefferson tells this incident. "And 'Rip Van Winkle' has made the Jefferson family rich," he adds. "Mem-

Thomas Jefferson in "Rip Van Winkle," there is a real dog Schneider.

The part of Schneider is played by Annie, a Russian police hound. Annie had a long career as a tracer of criminals near Petrograd. She was brought to this country for the picturization of "Rip Van Winkle" by B. A. Rolfe Photo Plays, Inc., which made this production.

It was not necessary to rehearse Annie as much as the average Broadway actor is rehearsed. Annie had the whole foundation of the art of acting at command. The training which the dog had received in Russia enabled the animal to fetch and carry any object that was indicated. A garment or an article belonging to any person would supply the scent and Annie would at once get or the trail of the person wanted.

In this new version of "Rip Van Winkle," the dog is of great assistance to Rip. If he is hungry, his dog Schneider gets him food, and gets it in full view of the audience. If he is thirsty, he only calls Schneider and the animal fetches liquor.

AMONG THE EXCHANGES

FRISCO FILM EXCHANGES FORM TRADE BOARD

THE film exchange interests of San Francisco have succeeded in the efforts to form an organization which have been under way for some time, and have drawn up a constitution and by-laws and elected officers. The new organization will be known as the Film Exchange Board of Trade of San Francisco and will be governed by a board of five directors. Its chief object will be the protection of its members and to afford a ready medium for co-operative work with exhibitors throughout the State of California.

This new organization is looked upon with much favor by the leading exhibitors, many of whom have expressed the opinion that their branch of the business had been made to suffer damage and loss of repute by unscrupulous members of the business.

At the recent convention of exhibitors held in San Francisco mention was made by a speaker of the fact that the film exchange men were organizing and J. Ray Williams of Sacramento commented at some length on this information, declaring that it was the best piece of news that he had heard in a long time and that he expected to see much good come of it.

The directors who have been chosen for the first term are: M. L. Markowitz, of the California Film Exchange, president; J. R. Crone, of the Mutual Film Company, vice-president; O. V. Tragardh, secretary and treasurer; Thomas North and Sol L. Lesser. At an early date offices are to be established in a downtown building convenient to the film exchanges.

ALCO OPENS DENVER EXCHANGE

THE Alco group of exchanges has been increased by the addition of the Alco Film Service of Denver, Colorado.

The newest Alco youngster will serve the territory embraced by Colorado, Wyoming, Utah and New Mexico. Grombacker and Bailey, two of the best-known film men on the Pacific Coast, have taken over the franchise, and of course are in direct charge of the new exchange.

Since last August seventeen Alco exchanges have been established over the entire country. From all points come reports of the utmost harmony; everybody in Alco is getting together and staying together. The managers report that the Alco Program is taking first place in the many cities which they serve.

PITTSBURGH EXCHANGES MAY HAVE NEW HOME

IS Pittsburgh to have a new home for exchanges? Will the old town of smoke find someone who will erect a fireproof building for their housing and take them from their old haunts in Film Row in the Fourth avenue-Ferry street district?

This question has been asked many times and it is likely that it will be answered shortly. A well-known business man of Pittsburgh who is heavily interested in the motion picture industry, it is said, has laid plans for the erection of a nine story building which will contain every safeguard against fire and provide, instead of a film row, a film centre which will be a convenience to all concerned as well as eliminate a menace to the city as the conditions surrounding the business now are.

The promoter of the scheme desires his name withheld for the present. He has options on several plots of ground in various parts of the downtown section, but the one favored and the one most likely to be used will be the corner of Wood street and Second avenue. The location is excellent.

Plans in the rough have been prepared for a nine-story building, 48 by 92 feet. This location gives a frontage on two streets and the lot runs back to an alley. Freight and passenger elevators will be provided and the necessary

vaults and safeguards against fire, such as asbestos compartments and water sprinklers.

The film men of the city have been worried of late on account of an ordinance that is soon to be introduced requiring them to keep their films in fire-proof vaults and make other changes about their plants that will make the industry more safe than it is at this time. The men say they will be put to an enormous expense and will in the end only have to remove from their present locations by other ordinances that will make it impossible to conduct their business in places where it now is transacted.

Many of the exchange managers fear to answer the telephone when it rings at night at their home after they have retired, saying that they are afraid it will be the announcement that Film Row is in flames.

The present quarters of the film men are such that should a fire start nothing short of a miracle would keep the fire from eating up all the exchange houses in that section. This is known to the men who are conducting the film houses and to the fire department of the city and it is with the "Safety First" sign in their minds that the city fathers are anxious to see the perils of the game eliminated as far as possible.

CAPITAL EXCHANGE MEN PREDICT GOOD YEAR

THE exchange managers of Washington, D. C., are optimistic to the point of enthusiasm over the past and future of the business in the nation's capital.

"My business has increased so much," declared Sidney B. Lust, of Warner's Features, "that I have established branches in Baltimore, Md., and Charlotte, N. C."

George H. Christoffers, special representative of the World Film Corporation, had this to say: "If there were closer co-operation between exhibitors and exchanges many unnecessary lawsuits, much money, and much disagreeable controversy could be saved. Market conditions are fine at present."

C. L. Worthington, manager of the Eclectic exchange, said: "The weeding out of the small, mediocre theatre and the high cost of living have assisted the motion picture business. Our exhibit room has been found very useful to exhibitors."

The Electric Film Supply Company, under the able management of D. W.

Smiley, reports business improving, and that the big productions are being held back for more favorable booking later. The Greater New York Film Exchange also has only a cheerful report to make.

The Mutual Film Corporation reports: "The Million Dollar Mystery' is going fine in the residential districts. Keystone comedies are in demand, as are also the one-reelers."

Mr. Lavelle, at the helm of the Universal forces, made this remark: "Business is excellent, but the long serials are losing favor. However, there is opportunity for short serials, covering from four to six releases."

ALCO IN NEW QUARTERS AT FRISCO

THE Alco Film Company has secured quarters in a splendid building now being completed at Eddy and Taylor streets, San Francisco, Cal. Pending the completion of the new offices the business of this concern is being carried on from the Golden Gate Film Exchange, 234 Eddy street.

LAEMMLE FILM SERVICE WILL OPEN BRANCH

THE Laemmle Film Service, with an exchange here, will open a branch at Sioux Falls, S. D., November 1, with Joseph Bradley in charge. The purpose is to save express charges.

The Omaha exchange, of which Fred A. Van Husan is manager, covers a wide territory, including Nebraska, Iowa, Kansas and the Dakotas. Express charges on films going to towns in the Dakotas were high, on account of the long distance, and the service was more difficult. With the district office the expense will be lower, because the films, after being sent from the Omaha office, can be circulated from the branch.

For every mile the film is sent by express, there is a proportionate chance for some delay or other trouble from which the exhibitor will be the sufferer. And there is also an express charge. Consequently, the customers of the Laemmle in the Dakotas were more likely to suffer from bad service, as well as getting films from one to two days later than they will with the branch office so near them.

The establishment of a branch office is something new in this part of the country. The feasibility of the plan is beyond question, however, and other exchanges may follow the example.

LOS ANGELES EXCHANGE INSTALS PROJECTORS

WILLIAM H. HEPBURN, manager machine and supply department of General Film Company Exchange, Los Angeles, has been a busy man during the past two weeks looking after the installation of a number of new machines. Two of these were placed in the American theatre, 452 South Broadway, owned by P. Geyurtz; two went to Glendale for the new combination vaudeville motion picture theatre built by H. C. Jensen; one was shipped to J. G. Scott, Calexico, Cal., for the new house being built at Mexicala—just across the Mexican border, and another was installed at the Tulane Theatre, El Centro, in order that feature pictures, used once each week, may be run without a stop for the operator to thread the machines. All were Power's 6 and 6a Cameragraphs.

SELDEN IN DETROIT

EDWARD D. SELDEN, personal representative of Lewis J. Selznick, vice-president and general manager of the World Film Corporation, is in Detroit working with Mr. Joseph Klein, the new manager of the Detroit office, in lining up business.

THROUGH EMPIRE STATE FOR ALCO

C. A. TAYLOR, who has been in the film industry since its start, is now traveling through New York State for Alco. He is closing many contracts with pleased exhibitors who have seen the Alco lines.

Alliance Companies Have Many Novelties

"Path Forbidden" Will Make Hit With Fine Double Exposure—"The Man Who Could Not Lose" Contains Distinctive Scenes

THE Excelsior Feature Film Company, Inc., releasing its productions through the Alliance exchange, has received many letters from different exchange men throughout the country commending it on the wonderful double exposure displayed in "The Path Forbidden."

There is a constant demand throughout the country for good features, and the Excelsior Company is living up to its policy of supplying pictures manufactured with the one and only idea of furnishing good clean entertainment in a pleasing manner.

The members of the Favorite Players Company were guests at a dinner given by Charles Neville Buck, author of "The Key to Yesterday," which was the book selected by the Favorite Players as a story worthy of being the initial feature of a new concern, whose policy is to produce only films of distinction.

Mr. Buck, author of many successful books and plays, made a long speech in which he complimented the company for the wonderful interpretation of the different characters they portrayed, and he was especially lavish in his praise of Carlyle Blackwell, whose insight and keen judgment enabled him to see the dramatic possibilities of Mr. Buck's book.

A paragraph of Mr. Buck's speech is recorded as follows:

"I consider it an honor to be present where I can personally congratulate Mr. Blackwell for his portrayal of the dual role of Marston, the world renowned artist, and Carter, the revolutionist and all-around bad man, which I thought, when writing this book, was a role so difficult that it was an impossibility for one man to play it, and still clearly portray the two widely contrasted characters."

HAZELTINE BANKRUPTCY PETITION

Special to MOTION PICTURE NEWS

Albany, N. Y., Oct. 27.

Edmund S. Hazeltine, of Albany, who is interested in the Washington Irving Amusement Company, of Catskill, filed a petition in voluntary bankruptcy last week, scheduling liabilities of \$29,728 and as assets of \$4,665.

Among the unsecured creditors are: The General Film Company, of Albany, \$152.40; Rex Film Company, of Albany, \$211; American Seating Company, of New York, \$427.90; The William L. Sherry Feature Film Company, of New York, \$50; The Ohio Flower Company, of Cleveland, \$28; The Boston Spray Company, of Boston, \$15.

ALCO'S DALLAS HEAD IN THE EAST

C. W. SLATER, of Dallas, Texas, who is the head of the Alco Film Corporation of Texas, with headquarters in Dallas, has been in New York for a few days, looking through the Alco local plants.

He reports a wonderful outlook in his territory for Alco and Atsco products. The Alco Film Corporation of Texas serves a territory made up of Texas, Oklahoma and Arkansas. Mr. Slater is preparing for the convention in Dallas of the interstate men. He says, when Dallas "pulls off anything," it is bound to be far more successful than any similar undertaking of any Eastern men.

Mr. Slater's organization is located at 1902 Commerce street, Dallas, Texas.

CALIFORNIA EXCHANGE WILL MOVE

THE California Film Exchange of San Francisco, M. L. Markowitz manager, will occupy new quarters about the first of December, arrangements having been completed for a removal from the present site on Seventh street, opposite the Post Office, to a large store on Golden Gate avenue. The new location is in the same block with the Box Office Attractions Company, the World Film Corporation, the Independent Film Exchange, the Union Film & Supply Company and some feature film concerns.

MUTUAL LOUISVILLE OFFICE TO MOVE

THE Louisville offices of the Mutual Film Corporation which were opened in the Inter-Southern Building, about two months ago, will be moved to the New Alamo Theatre Building about November 1. The Mutual has leased quarters there for a period of one year.

Manager Frank E. Hammer is spending much of his time at present visiting and becoming acquainted with exhibitors in this territory.

CHANGES AT ELECTRIC

SOME additions have been added to the force of the Electric Theatre Supply Company, Washington, D. C. These are: H. E. Reddish, who has been placed in charge of the Baltimore distributing branch and Earle E. Reese, who has been sent on the road in the southern district. G. W. Smiley, local manager, considers these men important acquisitions to Electric Theatre Supply Company.

ALCO INVADES CANADA

THE work of establishing the Alco program in Canada has begun. A. C. Langan is in the Dominion to the north of us in the interests of the releasing corporation. Since August Alco has opened seventeen exchanges covering the entire United States.

A Proposition for Exhibitors with a Punch

New Firm of Morrison and Poppe Launch an Idea Born of Long and Intimate Study of Exhibitors' Needs

INNOVATIONS in the field of motion pictures are so common that frequently they receive little more than passing notice.

The announcement, however, that Mr. Morrison and Mr. Poppe have entered the business with an absolutely new idea attaches special interest to this fact. Connected with the "Billboard" for several years, they worked side by side, but never until now have they deemed it advisable to get into the business for themselves.

Through their close contact with the business they became intimately acquainted with the needs of the exhibitor and evolved an idea which has culminated in the formation of a new firm operating under the trade name of Morrison & Poppe, with offices in the Times building, New York.



HARRY H. POPPE

Mr. Morrison is a man of intimate knowledge of the motion picture business and is widely known among the trade in all its branches.

For several years he served as manager of the "Billboard's" motion picture department in its New York office and was later made manager of the same pa-



E. V. MORRISON

per's Chicago office. Later he acted as manager of regular and feature exchanges. He is thoroughly alive to the necessities of the exhibitor, and promises that the new proposition he and Mr. Poppe have will fill a long felt want.

Mr. Poppe has also been connected with the "Billboard," but in later years was manager and advance representative of various road attractions. He, too, is familiar with the theatre in all its phases.

With the knowledge of the business that Mr. Morrison and Mr. Poppe possess, coupled with an ample store of energy and stick-to-it-iveness, and a proposition that is a boon to the exhibitor, it behooves every manager to get in touch with the new firm at once.

Their first advertisement appeared in MOTION PICTURE NEWS of October 24.

Neff Meets Wolff at Rochester

Subject of Conference Between Ex-President of League and Empire State Head Kept Secret—Trigger Also Journeys Up-State

Special to MOTION PICTURE NEWS

Rochester, N. Y., Oct. 22.

THAT there is something brewing in state politics among the motion picture exhibitors is shown by the fact that former President Neff, of the Exhibitors' League, was in the city recently, in conference with A. N. Wolff, president of the New York State Branch of the league.

Mr. Wolff said that the former president spent several hours with him and one or two other local exhibitors during the evening at a local hotel, but would

say nothing as to the subject discussed at the conference.

So far as is known there is no change in the attitude of the present officers of the state branch of the league toward the independents. The league is waiting for those who left the organization to make their individual applications for reinstatement.

Mr. Trigger was also reported to have been in this part of the state during the week, visiting Buffalo for a conference with exhibitors there.

ARTHUR R. TUCKER.

GRAU VOLUME IN SECOND PRINT

The Broadway Publishing Company, of 835 Broadway, N. Y., is a busy place in New York these days. From morning until night the 'phone is ringing with orders for shipments of Robert Grau's new volume on the motion picture industry.

Almost every volume sent out produces additional orders from the same source, and it is a remarkable fact that despite the enormous shipments the demand is still unsatisfied.

If any evidence were needed that this work is the only one covering every angle and phase of the wonderful new motion picture art, the demand proves it.

THE "TRADE MARK GIRL" OF OZ

Scores of letters have been received at the Oz Film Company's offices asking the name of the trade mark girl of the Oz pictures. One writer suggested that she be known as the Oz girl with "the



VIVIAN REED

million dollar smile," and from now on, according to President L. Frank Baum, she will be.

The smile is the property of Vivian Reed, formerly an artist's model in New York City, who came to the West coast on a pleasure trip. A want ad. calling for sixty pretty girls to work in pictures took Miss Reed to the Oz studio. There the directors, in invoicing the appearance of the girls, placed Miss Reed in Class A, and a few days later she was given a contract with the company for a long term of months. Officers of the Oz company believe they have a rare find in Miss Reed, and she is to be given every opportunity to display her talents.

STAR AND SCENES IN "SALOMY JANE," CALIFORNIA MOTION PICTURE CO.—ALCO FEATURE

SALOMY KISSES "THE MAN"

BEATRIZ MICHELENA.

MARBURY HELPS SALOMY TO ESCAPE.



BUSHMAN FALLS HEIR TO \$25,000 FORTUNE

Francis X. Bushman, Essanay's leading man, has been left a fortune of \$25,000.

The widow of Marshall Bushman, of Death Valley, called at the Essanay plant to see the actor. She said her husband, just before his death recently, had seen a moving picture show in which Bushman was starring. He declared the actor was his cousin whom he had not seen since childhood, and bequeathed him a part of the fortune he had made in mining. The actor could not remember such a cousin, but was willing to take the money on a chance.

Mrs. Marshall Bushman has gone to the actor's home in Norfolk, Va., to trace the relationship.

Long Heralded Alco Release Ready November 2

"Salomy Jane," Bret Harte's Famous Story Depicting the Stirring Days of '49 in California, Has Many Gripping Scenes

BEATRIZ MICHELENA in "Salomy Jane," the Alco release of November 2, presents to the picture loving public a peculiar type of heroine.

Salomy is cold and tender in turn. It is nothing to her to demand at the hands of Rufe the death of the man who has insulted her, for she is the daughter of a Kentucky feudist, and to kill a man is a mere incident in her primitive code.

Yet when "The Man" comes, her coldness disappears and melts into resource for the man she loves. She is quick to face peril for the man; she is all tenderness in her efforts to save him.

This dual quality in Salomy Jane, the

heroine, leads to the picturing of many thrilling scenes. If Rufe tries to embrace Salomy, she instantly repulses him with a gun, and when The Man is hunted for the murder of Baldwin, she unhesitatingly shares all dangers with him.

Another scene due to the dual personality of Salomy is that in which the heroine and The Man escape down the river screened behind a log, while the bullets of the passing posse strike harmlessly the log.

Salomy Jane has great charm as a heroine. In spite of her fiery Kentucky spirit, the men of the California mining camp are at her feet. Jack Marbury, the gambler, who loves Salomy, feels her charm to such an extent that he allows his rival, The Man, to escape. Later Marbury aids Salomy to dash from the midst of a posse which is about to detain her.

In her dealings with the men of the posse, Salomy is cold and resourceful. But she is again the tender girl when The Man is about to be hanged. The Sheriff asks if anyone will bid The Man good-bye, and Salomy unhesitatingly kisses him.

While "Salomy Jane" as a picturization is unusual for its number of gripping scenes, the photography also is remarkable.

As the spectator sits in the darkened theatre, the days of '49 live before him. The illusion is so great that the audience shares with breathless interest the perilous adventures of this interesting type of heroine.

WILKES-BARRE THEATRE BOOKS UNIVERSAL SERVICE

Special to MOTION PICTURE NEWS

Wilkes-Barre, Pa., Oct. 28.

Clayton Heebner, manager of the Alhambra Theatre, this city, announces that he will use the Universal service in the future

"Inceville" to Have Its Own Wild West

New York Motion Picture Company Ends Contract with Miller Brothers and Engages Fifty Cowboys, Two Dozen Indians and Buys 150 Horses

A DRASTIC change in the affairs of Thomas H. Ince's New York Motion Picture Corporation—expansive in its scope and important from a standpoint of prosperity in film production—took effect on October 16, when the picture company and the Miller brothers agreed to a discontinuance of the contract whereby cowboys, Indians and live stock were furnished for purposes of the screen.

Hereafter, therefore, instead of employing its men and horses from the ranch owners, Inceville will control all its equipment. Steps toward the carrying out of this plan were taken several weeks ago, when it was first decided not to renew the contract and as a result of Mr. Ince's activities, fifty men, two dozen Indians, 150 horses and several hundred head of cattle and other live stock are now being housed at the company's camp in the Santa Ynez canyon under the absolute control of the film-producing company.

The history of the Miller brothers'

connection with the Ince companies dates back to the latter part of 1911, when Charles O. Bauman, one of the high officials of the New York Motion Picture Corporation, was impressed by the manner in which members of the Miller brothers' traveling wild west show expedited matters at a little town in Arizona.

Mr. Bauman immediately entered into negotiations with the Miller brothers and shortly thereafter contracted with them for the use of cowboys, Indians and live stock.

At the suggestion of Mr. Ince, however, last summer plans were discussed for a discontinuance of the contract upon its expiration on October 16. The suggestion met with favor at a meeting of the board of directors and the aggregation of cowboys, Indians and live stock was at once employed. The entire change, it is understood, represents an investment by the company of more than \$15,000. The new plan, however, is expected to give entire satisfaction.

In and Out of Los Angeles Studios

Special to MOTION PICTURE NEWS

Los Angeles, Oct. 26

THOMAS H. Ince has made a contract with William S. Hart, who made his debut in pictures in the big seven-reeler, "The Two Gun Men," produced by Mr. Ince, to appear in pictures and direct a company for the New York Motion Picture Company for a term of months.

The exact length of time is not stated, but from unofficial sources it is reported that Mr. Hart will remain at the Inceville studio for two years. It is also reported that a six months' contract has been made with Bessie Barriscale and her husband, Howard Hickman, who have been at the Lasky studio.

Shorty Hamilton, comedian of Domino, Kay-Bee and Broncho brand pictures, and Ethel Spurgint, actress at a local theatre, were quietly wedded one evening last week at the home of the parents of the bride, in Venice. Neither members of the theatre stock company or the photoplay companies were advised of the event until after the wedding.

The couple met six weeks ago when Shorty appeared at a Venice theatre to tell the patrons why he did so many funny things before the camera. The manager of the theatre is now demanding another explanation.

"The Political Feud" is a two reel Ince production in which Richard Stanton plays leads and directs. The story treats of a poor lad's rise to success in spite of many obstacles.

George Osbourne is again in charge of his company at Inceville, after spending several weeks at his raisen ranch in the northern part of the state. George reports crops are good.

Another Series is On the Way

Otis Turner, director general of the Universal studio, is writing and producing a series of detective pictures, featuring Herbert Rawlinson as Sanford Quest, scientific criminologist. Work was commenced on the production of the first during the last week, as properties for "The Suburban," from the well-known play, were not ready for the company to begin the making of that four-reel feature directed by Mr. Turner.

Each of the Sanford Quest pictures, consisting of two reels, will be complete within itself, and aside from the character of Quest and his assistants, new characters will be introduced in each of the series.

The J. Warren Kerrigan—Jacques Jaccard Victor Company—are now filming the third two-reeler of the Terrance O'Rourke pictures, the second having

been completed on the Mojave desert during the past week.

Last week the third series, "The Inn of the Winged God," was filmed. The scenes represent Lutzenburg, where O'Rourke goes in search of the kidnapped daughter of the duchess. For several weeks Mr. Kerrigan and Billie Quinn were practicing broadsword and rapier fencing, for scenes in this picture, and their instructor saw that they staged an absolutely correct fight.

The itinerary of the O'Rourke company includes Kara Dagh, in the Balkans; Tangiers, Bombay, Grecian Archipelago, Algiers, Southern France, Port Said, Cuba and other places, but they will not leave Los Angeles, Cal., while on the trip.

In the absence of Al Christie, Nestor director, who is now on his first vacation in three years—spending the time in New York—Eddie Lyons, he of the attractive smile, is taking the part of directing the Nestorites—Lee Moran and Victoria Ford—in two pictures, both comedies, "Love, Luck and Smallpox," and "Jed's Little Elopement." Both will be of one reel.

Elaborate Sets for "Master Key"

It was a very enthusiastic group of photoplayers that emerged from the U projecting room, after witnessing the first two installments of "The Master Key," the next Universal serial. Of the many excellent scenes those of the camp fire, made at night under the direction

of Robert Leonard, received the greatest praise.

The company has now taken up the third installment which begins the story—the first installment showing a prologue. This serial carries a synopsis of preceding installments at the beginning of the first reel.

A very elaborate mining town of some forty buildings has been erected at Universal City for this picture, and many of the exteriors are being made there. One of the sensational scenes of the third series will be the rescue, by Leonard, playing the part of the mine engineer, of the daughter of the mine owner.

The girl will be carried down the steep incline in a mine car. Leonard sees her plight, and leaping into a mine bucket suspended from a cable crossing the car tracks at right angles, hangs by his knees and lifts the girl out of the car and carries her to safety.

"The Trey o' Hearts" company has filmed the last installment—No. 15—of the Louis Joseph Vance story, at Mission Inn, Riverside, Cal., and following the completion of this all will take a vacation.

The fifteenth installment ends everything happily. In installment seven or eight Judith Trine and Alan Law were married, but later the ceremony was said to be illegal. Judith finds that it is legal.

Her father, Senica Trine, by a fall down the mountains, recovers his senses



JOSEPH DE GRASSE AND HIS COMPANY OF REX-UNIVERSAL PLAYERS IN THE ANGELES NATIONAL FOREST, CALIFORNIA

ost
ave
lost
ose

thought to have been destroyed by paralysis following an auto accident, and arrives at a little country church just as Alan and Rose are to be married.

He raises a revolver to shoot Alan when a bolt of lightning kills him and Rose and renders Alan unconscious. Judith then claims Alan as her husband and they are reconciled. Many of the scenes are made in Mission Inn lighted for the occasion by Winfield-Kerner actinic ray lamps, manufactured in Los Angeles.

Unusual Love Story

The Lloyd Ingraham-Powers Company, including Edna Maison, Bert Hadley and Joe King, were spending a week recently at Arrowhead Hot Springs, Cal., utilizing the heretofore un-photographed scenery in the filming of an unusual story. This deals with a city maiden, a daughter of the idle rich, who goes to the fashionable resort in the Canadian timber country to recuperate her health after a strenuous social season.

There she meets a woodsman who falls in love with her. The novelty of being courted by an uncouth son of nature pleases the maid and she encourages him. When he shows her a small log cabin he has prepared for her when she becomes his bride, she laughs at him. Months later she is to be wedded to a city man.

The guests have assembled at the church, and a package marked a wedding gift is delivered to her by a messenger. She finds a note explaining that inasmuch as the young woodsman gave himself up to her in his life, he should also be hers in death. Inside the package is the woodsman's skull with a bullet-hole in the forehead. The girl becomes a maniac.

George Beban, working in the big Thomas H. Ince production, "The Italian," had a narrow escape last week, when he insisted upon doing a fall from the rear end of a moving automobile on North Main street, Los Angeles. The scene was taken at the Plaza, a small park where many Mexicans congregate.

Inceville Studio Threatened by Fire

He attempted to climb over the back of an automobile, in which a politician he had helped to put in power was riding, but who refused to recognize him when he was facing arrest. The auto was followed by the one from which the picture was taken, and the motorman of a street car, because of the second auto did not see Beban fall and roll onto the car tracks.

The street car was brought to a stop but a few inches from where Beban lay, unconscious from striking his head on a rail. He was rushed to a hospital and was able to resume work in a few days.

Inceville, the New York Motion Picture Company's studio at Santa Monica Inyon, was threatened with destruction by fire the past week, during the production of an underworld story by Scott Sidney.

A large portion of one set was lighted



A SCENE FROM "THE ROSE OF THE RANCHO"
(Lasky-Belasco—Paramount Feature)

in order to secure realistic effects, believing that it would be possible for the stage hands to extinguish it without difficulty. Everything being dry the fire gained headway very speedily and was spreading to other sets before it was gotten under control. Harry G. Koeman, an actor, was badly burned about the hands and arms.

Reliance Director Jack Adolphi filmed another crook picture last week, featuring Eugene Pallette, supported by Francelia Billington, Sam De Grasse and F. A. Turner, "The Kafir's Skull," adapted from the short story of the same title by James Francis Dwyer.

Wallace Reid is playing the part of a "tightwad," in a picture by that name being filmed under the direction of Majestic Director Donald Crisp. The story is by W. M. Ritchey and is of a heart interest nature.

Feigning insanity, Baldy Belmont, as the husband of Mrs. Henpeck (Fay Tincher) in "Out Again and In Again," a Komic brand comedy produced by Eddie Dillon, escapes from his wife for a night off with the boys, only to be recaptured and taken home for a more severe pecking.

Dorothy Gish in Tense Picture

The company has just completed number eleven of the Bill Series, from the Paul West stories, in which Miss Tincher, as Ethel the stenographer, appeared in a brand splinter new "gown," that put to shame all her previous "creations," and is a noise maker in itself. Besides Mr. Dillon, who plays the part of one of the lovers, Tammany Young, as Bill the office boy, and Miss Tincher, the cast includes Tod Browning, Anna Mae Walthall, Mae Ashton, Mae Gaston, Lucile Brown and Max Davidson.

Playing the part of an illiterate daughter of the village drunkard, Dorothy

Gish, featured in the name part of the two reel Majestic picture, "A Child of God," is educated by and falls in love with the minister. Later when she sees him embrace another young woman she tries to induce her father to kill the minister. Then she learns the other woman is his sister. The picture is being produced by W. C. Cabanne and the cast includes F. Burns and G. Seigmann.

"The Folly of Ann," an adaptation from the story of the same name by Ellen Farley, was filmed last week for a Majestic release by Jack O'Brien, with Lillian Gish in the name role and Jack Conway playing the male lead.

"Sheriff" Mackley's Record

Publicity Chief W. E. Keefe, of the Reliance-Majestic studio, in order to facilitate his department in keeping an accurate record of the number of pictures Arthur Mackley appears in as a western sheriff, has placed a heavy piece of timber near Mr. Mackley's office, and requested him to register—with a bullet—each time he completes a picture containing such a part, feeling sure that the producer of thrillers of the plains would be more apt to remember this kind of registration as it would be most convenient.

Mr. Mackley always wears his belt with a six-shooter on either side. Pencils are not always so handy. When the timber was placed in position the number totaled even two hundred. Now there are three bullet holes indicating the completion of "The Hidden Message," "The Widow's Mite" and "The Miner's Peril."

The Albuquerque Film Company players have taken up the filming of additional releases of The Frontier Twins series, featuring Dot Farley. While with the St. Louis Motion Picture Company several months ago Miss Farley originated this series.

The first release of the Albuquerque company through the newly organized United Motion Picture Producers, Inc., will be "Reuben's Busy Day," a comedy produced by Archer McMackin, November 12. Following this will be "A Sage Brush Leading Lady," November 19, and "Soul Mates," November 26. The two latter pictures were directed by G. P. Hamilton and featured Miss Farley.

Apfel Stages Free Circus

Oscar Apfel, directing the production of "The Rose in the Ring," featuring Theodore Roberts as the Ringmaster, entertained Hollywood people one afternoon when he gave a free circus. The largest tent obtainable was erected on the vacant lot adjoining the Jesse Lasky Feature Play Company's studio, and the interior of this was the scene of the big show.

The acts included bare back riding, Roman chariot races, trapeze and horizontal bar acts, and numerous stunts by the clowns, all of which were filmed. Following the performance all members of the company posed in front of the big top for a photograph.

"The Man Who Could Not Lose" has been completed by Carlyle Blackwell's Favorite Players and the negative film and print are now on their way to New York, after having been viewed by members of the company. The players are now engaged in filming another Richard Harding Davis story, "The Last Chapter."

Sid Chaplin, brother of Charlie, is to arrive at the Keystone studio and will begin work at once.

Mack Sennett and Charlie Chaplin had a lot of fun making a comedy of a prehistoric character, in which Chaplin is a hero of the Stone Age. This is the first time the Keystone players have attempted anything other than modern settings.

Roscoe Arbuckle has been making an unusual comedy at the Keystone studio in which he displays his ability at tight rope walking by escaping from his followers by walking a clothes line across a court of the buildings from one six-story window to another. Of course, the picture fans will think it is a clothes line, but instead of half inch steel-wire cable was used to support the 315 pounds of Arbuckle.

A satire on the melodrama of the stage of today is being made by Chester Conklin, for the Keystone release, in the subject, "Curses, They Remarkd." "This is not the usual rotgh-stuff," a Keystone director said concerning the picture, "but is one in which every one will see a lot of good clean fun." One of the big scenes will be that of the stealing a girl from an automobile by the villain who rides horse back.

Ready for the "Golden West"

Members of the Lasky producing company Monday evening saw their work in "The Rose of the Rancho," when the first print of the picture was projected at the studio, prior to being sent to New

York. "The Rose in the Ring," directed by Oscar Apfel was finished last week. Cecil de Mille will now take up the filming of "The Girl of The Golden West," featuring Mabel Van Buren.

Los Angeles sweltered in an unusual



SYD CHAPLIN

heat wave recently and this was no doubt felt keenly by photoplayers. The mercury played about the century mark almost every day, and the blazing sun made the screened stages at the studios veritable ovens. In one or two instances it was necessary to discontinue work during the hottest hours of the day.

Don Meaney, who recently came to Los Angeles to do special publicity work for the Universal, relative to the opening of the new Universal City, is now busy compiling a book concerning the only city in the world devoted exclu-

sively to the production of pictures.

While it has not been announced when distribution of this book will be made, it is understood it will serve as Christmas remembrances. The souvenir will consist of between one and two hundred pages, of large dimension, and printed on extra heavy enameled stock. Each page will contain three or more illustrations, pictures of different scenes of the city being used.

"The Sign of the Four," from the play of the same name in which William Gillette starred several years ago, has been filmed under the direction of Francis Forde, who played the lead part. Grace Cunard played opposite Mr. Forde.

Veteran Joins Universal

Charles Manley, the veteran actor, makes his first appearance in pictures in a two-reel picture filmed under the direction of Joseph de Grasse, "The Sin of Olga Brandt." Pauline Bush is featured in this and other members of the company are William Dowlan and Lon Chaney.

This is a story of a girl who sacrificed her honor in order that her sister could be provided with funds for a necessary operation. The operation being unsuccessful, the girl goes to another place to begin life anew. There she becomes the wife of a minister who with the deacons of his church play a prominent part in the moral uplift of the community. A white slave motion picture, a replica of the girl's early life, is brought to the village theatre, and the churchmen act as censors.

The minister, while pondering whether the picture should or should not be shown, reads "Judge not that ye be not judged," in the Bible lying open before him, and secures permission for the film to be shown.



SALOMY JANE IS ACCUSED OF MURDER

Scene from "Salomy Jane" (California M. P. Corp.—Alco)

lost
have
the most
will disclose

"JOHN BARLEYCORN" PACKS LYRIC

Special to MOTION PICTURE NEWS

Minneapolis, Oct. 27. "John Barleycorn" has won its fight if the record in Minneapolis is a criterion. The film was shown at the Lyric Theater a little while ago to packed houses, and not a suggestion of an attempt was made to have it censored or stopped.

Minneapolis is not a city that is without its power of the liquor interests being manifested when there is a chance for a winning, but in this case there wasn't a fighting chance.

The people talked of the film long before it was shown. The newspapers carried advance matter purely on its news value in addition to the press notices. Picture houses in Minneapolis have a clean bill and the liquor interests apparently knew that if the play had been billed it was clean, and that if the exhibitor and film man had decided to back it, they would get away with it. The film was popular with all classes, and was well patronized by educators, ministers and others who select their films carefully.

POLITICAL CANDIDATES ON SCREEN

Special to MOTION PICTURE NEWS

Phoenix, Ariz., Oct. 27.

What is perhaps the first attempt of political candidates, at least in this section, to use the screen for advertising purposes is to be tried in the coming state Arizona election.

A motion picture concern is writing a scenario which will disclose in a reel the several candidates of the party which is to make use of it. The picture will show all of the men who are running for office in a story that will be sent out over the state on a pay basis.

Slides have been employed in many instances for the popularizing of a candidate, but a combined effort along film lines is a new one here. Just how it will meet the end for which it is designed is hard to say. Many things have been accomplished by the "nervous" photographs, so why not swaying elections?

New "Neptune's Daughter" Company Out

Sent on Tour of First Class Houses Like Old Line Road Troupe and Is Shown at Percentage Rates—Unusual Line of Paper Shown

SO great has been the demand for Annette Kellermann in "Neptune's Daughter" from the theatre-going public of the United States and Canada that another company will be sent on the road October 25, opening Scott's Metropolitan Opera House, St. Paul, Minn.

Similar to all the other "Neptune's Daughter" companies now on tour the circus theatres will be played by this one of the recognized theatrical

edney. A large fortune has been put

A large portion of this attraction,

Loving Cup Presented to Mary Pickford

Australian Public Shows Appreciation of Her Acting by Sending Gift Ten Thousand Miles—Souvenir Purchased with Thousands of Pennies

A SPONTANEOUS and pleasing demonstration was accorded Mary Pickford, the Famous Players' popular star, when Millard Johnson of the Australasian Film Company, representing the exhibitors and public of Australia, brought her an immense silver loving cup and a big album of autographs from her admirers across the Pacific, as a mark of appreciation of her art.

Mr. and Mrs. Johnson arrived at the

Mr. Johnson announced his mission, and explained that the idea of tendering Miss Pickford this unusual tribute emanated from the Greater J. D. Williams Amusement Company on the occasion of the star's triumph in "Tess of the Storm Country," and met with a general response from the Australian public.

Attached to the album is the great seal of the city of Sydney, which has, it is said, never before been attached to any



DANIEL FROHMAN PRESENTING MARY PICKFORD WITH THE SILVER LOVING CUP FROM AUSTRALIA AT FAMOUS PLAYERS STUDIO

studios of the Famous Players with the gifts while Miss Pickford was rehearsing a scene from "The Stepsister," one of her forthcoming releases, and Daniel Frohman, representing the company, stepped upon the stage and stopped the scene, to the surprise of star, director and cast, while he ushered on the representatives of the thousands of donors who had contributed to the fund with which the loving cup was purchased.

but official documents. The album also contains the official signature of the lord mayor of Sydney and the official attestation of the town clerk. The signatures in the album are each and every one the bona-fide autographs of "Little Mary's" admirers, who voluntarily placed them there as a tribute to her art and popularity.

The loving cup was purchased with 13,651½ Australian pennies, each one of which was voluntarily dropped into glass jars placed in the lobby of the Crystal Palace for this purpose.

A motion picture was taken of Mr. Johnson's presentation and Miss Pickford's acceptance of the cup and album, which will be sent to Australia, so that the donors of the gifts can see the scene enacted ten thousand miles away from the source of its origin.

On the cover of the album are impressed the lines, "The Roll to Honor Our Little Mary Pickford—a Tribute from Australia," and on the fly-leaf appears the following: "Art is universal, human sympathy international, genius the property of the world. Your 'Tess,' Mary, is ours. She will live long in our hearts—we love you for her."

and the pictorial display of paper is unusual.

A complete and up-to-date equipment, skilled mechanics, well known advertising experts, and theatrical men being employed by these various companies, insure resident managers in all parts of the country the most hearty and effective co-operation. The business for this attraction and all other special features manufactured by the Universal will be handled through the recently established Universal Booking Offices.

"WHAT'S HIS NAME"

(Lasky-Paramount—Five Reels)

REVIEWED BY CLIFFORD H. PANGBURN

ALL of the factors which are necessary in turning out a good film have been looked after by the producers of this feature in a manner which leaves little to be desired. The result is that, mechanically speaking, it may be said to be a nearly perfect piece of work. This, combined with strength of plot and excellence of acting, provides a picture of unusual merit.

A rather unusual fact about the film is that nearly all of the scenes are interiors. Such stories are the ones that are most often bungled, either by ignorance or parsimony, or both. There is no bungling in "What's His Name," however. The various scenes have been arranged with great care, and this in spite of the fact that many of them are decidedly unusual.

For example, a number of the incidents in the story



HARVEY BREAKS UP A PARTY

take place about a soda fountain. Instead of employing a beer faucet stuck into the wall, as has been done for such a set, a real soda fountain with all its appurtenances is used.

The scenes which take place in the theatre, both behind the scenes and in the auditorium, are also unusually well done. These and many other fine settings give the picture a most remarkable degree of realism. The spectator is made to feel as if he were one of the characters, which is the only test of realism.

As mentioned above, the exterior scenes are few in number, but such as there are come up to the standard set by the other parts of the film. Good photography and tinting is found throughout.

The case contains a number of familiar names. The title role is played by Max Figman, who handles a part calling for a wide variety of acting. His work is more than creditable. Lolita Robertson as his wife is equally effective. Although appearing in only a half dozen scenes in the last reel the doctor's role is played with realism and naturalness.

The story starts in a country town where the soda clerk of the drug store marries the baker's daughter against the wishes of the girl's bachelor uncle. After three years of happy but impecunious married life she meets a chorus girl of a show which comes to town, and as a result joins the chorus.

Her husband and their little daughter Phoebe go to New York and the husband keeps house while his wife is attending to her theatrical work. Nellie, the wife, becomes a star and establishes her husband and daughter at Tarrytown. Learning of the advances of a millionaire towards his wife, the husband quarrels with her and is turned out of the house.

He keeps the little girl with him and goes home. Her season ended, the actress goes to Reno to get a divorce. There she learns of the real character of her rich suitor,

and hears of her daughter's illness. She abandons the idea of a divorce, rushes home and there is a happy reconciliation at the bedside of the child, who is out of danger.

This is a good heart interest film which holds the interest from start to finish and should prove of cash value to any exhibitor.

"THE MILLION DOLLAR MYSTERY"

(Thanouser—Nineteenth Episode)

REVIEWED BY PETER MILNE

THE actors and actresses that have appeared in the episodes of "The Million Dollar Mystery" have given excellent accounts of themselves. Their work, although requiring less dramatic art than the parts in a plain picture would call for, has been exceedingly daring, and whenever the principals have been called upon to exercise their histrionic ability, they have shown themselves equal to any and all situations.

But here in this number, although the principals perform in the same decisive and finished manner, their efforts will be well-nigh overshadowed and eclipsed by the remarkable intelligence displayed by the Thanouser collie dog. This canine may not care a whit whether he receive credit for his work or not, but be that as it may, he deserves praise, and shall be allotted it.

It is one thing to "sic" a dog on a box-car tourist, but it is entirely another to teach him to attack his friends. We do not know for sure whether the conspirators of "The Million Dollar Mystery" are his friends or his enemies, but it is reasonable to suppose that all the members of the Thanouser company are his friends. At any rate, he attacks a number of them in the water with visible fierceness, and it is an exciting moment for actor and spectator.

The situation that leads to the startling performance rendered by the dog is that in which Flo has procured some papers, which relieve her father from persecution from the conspirators. She swims away with them from the underground meeting place in a river running sub-terra. Braine pursues her in a rowboat, and when out in the open bay over-



FLO STEALS THE PAPERS

takes and captures her. Jim, who was strolling along the bank with his dog, swims to her rescue.

He pulls Braine out of the boat and engages in a battle-royal in the water, when a number of toughs in a motorboat come to Braine's aid. The dog, seeing his master getting the worst of the argument, plunges in to the rescue, and holds the conspirators at bay, while Jim and Flo man the power boat; they rescue the dog and escape.

This intelligent performance of the four-footed creature will undoubtedly call for much comment. And this is not the first time that the same dog has been in the lime light. It seems that he is a born actor, and plays his parts almost as well as humans do. The producers of this story have introduced many innovations, but this seems about the most unique up to date. Perhaps the last chapters will disclose even better ones

"THE PINES OF LORY"

(Edison—Two Reels)

REVIEWED BY CLIFFORD H. PANGBURN

THIS is a picturization of the novel of the same name, by J. A. Mitchell. The story is an unusual one, and the scenes are laid for the most part on an island near the mouth of the St. Lawrence.

A large number of attractive scenes supposed to be on this island appear in the picture, and add to its interest.

Except for an occasional anachronism, the film, taken as a whole, is a good one, and offers a story which holds the attention closely. Elinor Marshall plays the principal feminine



"YOU ARE REALLY A MURDERER!"

part. Other important members of the cast are Richard Neil, Bessie Lyons and Matilda Barry.

The story deals with two sets of characters who are brought together in a strange way. Patrick, a young Irishman, is banished from home by his elder brother on the death of his father, the brother's reason being that the younger son had practically killed his father.

Some time later Patrick met a girl who was a dear friend of his sister's. The meeting took place on a Canadian steamer. Having heard only the family's side of the story, she was extremely cold to Pat.

Both were bound for the same place, but in a dense fog were put ashore on a landing at the wrong island. There they found a strange house completely abandoned, but supplied with food.

Later, they found the body of the owner. Left alone on the island the enemies became friends, and then lovers. After various unpleasant experiences they were rescued by the family of the island's owner.

He was a French duke who had fled from his native land and lived the rest of his life on the island. On reaching home Pat is welcomed, and the family do their best to make up for their outrageous treatment of him.

"WHEN HIS SHIP CAME IN"

(Selig—Two Reels)

REVIEWED BY T. S. MEAD

THIS production will prove very popular with the many admirers of Gilson Willets' scenarios. It is an excellently produced drama of the sea, containing many beautiful marine scenes. The part of Neptuna, a pretty and vivacious girl of the fishing village is charmingly played by Bessie Eyton. Thomas Santschi as Josh Rollins, her lover, is also very good, and both are ably supported by a cast including Harry Lonsdale, Franklin Hall and Thomas Bates.

Neptuna despises the uneventful life she leads with her impoverished grandfather in the small fishing village of Home Port. She longs for the city and money, with all the things it can buy.

Josh Rollins, a sailor on his uncle's schooner, The Maid of the Mist, loves Neptuna, but she, in her discontented mood refuses to marry him, because he is poor. His uncle is appealed to, but he thinks Neptuna a mercenary girl with-

out love for Josh, and in the disagreement that follows Josh refuses to sail on the next cruise.

Neptuna secretly departs for the city, leaving a note that Josh is not to follow her until, as she puts it, "his ship comes in." A few weeks later, Josh receives word that his uncle has died, leaving him his schooner, which is bound home with a load of gunpowder.

In the meantime, the penniless and homesick Neptuna has lost her position in the city, and in the midst of her despair, wanders to the wharves, where she discovers the Maid of the Mist about to sail. She resolves to return home and stows herself away in the hold. During the trip, a fire breaks out. The crew deserts the boat, and its dangerous cargo.

Fortunately, for Neptuna, a large wave breaks over the deck, extinguishing the fire before it reaches the powder. Neptuna, alone, on the deserted ship, exerting all her nautical knowledge, guides the boat to port, after a twenty-four hour struggle. Then she and her lover are happily united.

"THE OLD FOGEY"

(Pathé—Three Reels)

REVIEWED BY CLIFFORD H. PANGBURN

THIS picture is a fine example of what can be done in American studios by the exercise of a little care. There are no very great demands on the producer in the story, but many of the scenes require settings of a very special nature.

These are the views which take place in and about a circus tent. Settings of just this sort have been faked in some films, with a resultant lack of any faint resemblance to the real thing. The circus scenes in this picture were taken in a real circus tent. It is a small one, but it is real, and the atmosphere of the story is thus made convincing



THE OLD FOGY MAKES TROUBLE

Another example of the good settings is seen in the part of the story which takes place inside of the private railroad car of the circus owner. This is perhaps the best car setting shown in many months.

An escaped circus lion adds a remarkable touch to a part of the picture. He leaps upon the depraved ringmaster and rolls down a rocky declivity with him in a style which leaves little to be desired in the way of thrills.

A middle aged bookkeeper is invited to the circus by his employer. He dreams of his first circus at which his sweetheart became so infatuated with a ringmaster that she ran away with him. Going to the circus he finds his former sweetheart is there with her lover who has never married her, and is now spending much time with another woman. She has become hardened by her life and regards the bookkeeper as an amusing old fogey. She even gets \$10,000 of his employer's money from him by a very old confidence game. Ultimately her false lover, who prompted her to the act, is killed and the money comes into her possession. She returns it to the old fogey, but he will have nothing more to do with her, and she goes away broken hearted.

It is an interesting and extremely well done story. In the cast are Sam Coit, Nell Craig and Walter Hitchcock.

"SALOMY JANE"

(California-Alco—Six Reels)

REVIEWED BY PETER MILNE

IT takes an unusual amount of courage for a concern to produce a western feature. Hatching up Westerners seems to have been the favorite indoor sport of many producers during the past year, so that the market has been flooded with them; some good, some bad; the good ones have not created much comment, while the bad ones have gained such a name for their class that they are very often steered cleared of.

But with the case of "Salomy Jane" a different story is to be told. The picture is clearly the work of experience. Bret Harte wrote the original "Salomy Jane's Kiss" on which the picture is based.

Paul Armstrong converted the story into a play and from that it was adapted to the picture, which Alex E. Beyfuss has directed. Bret Harte had a clear and concise idea of the West, and no man was better qualified to write about it than he.

That the director was blessed with an artistic nature, will be obvious as soon as the picture has been seen. There is hardly a scene which is not beautiful.

All the exteriors were taken in the giant redwood forests of California, and no more artistic backgrounds could possibly have been found. They would have been completely lost, however, unless they were not supported by excellent photography. Beautiful light and shadow effects have been caught in almost each scene. Photographically the whole production is of the highest order.

The acting, the dramatic end of the picture, equals the technical end. Beatriz Michelena is featured and gives a clear interpretation of the fiery Salomy Jane Clay. House Peters makes a fine "Man"; his build and his actions suit him well to his part. Clarence Arper as Colonel Starbottle holds the comedy role of the picture, and plays it with great understanding. Without the genuine comedy touches that he instills in each scene in which he makes his appearance the picture would lose much of its charm.

There are many others in the cast. Those holding the more important parts are Andrew Robson as Yuba Bill, Matt Snyder as Salomy's father, Harold Meade as Baldwin, Ernest



SALOMY DEFENDS HER LIPS FROM RUFÉ

Joy as the gambler, and William Nigh as Rufe Waters, the coward of the play, and the one who almost spoils the pleasant romance that only terminates in the last scene.

The story hardly needs relation, but suffice it to say that it is so far above the average Western, that it will stand out like a bright star from its more mediocre constellations. In a few places the producer has caught such beautiful and extensive scenes with the camera, that he has been tempted to lengthen them, so that their length seems unnecessary, but this fact may be obliterated before the picture is released as when he saw it, it comprised seven reels. It is safe to say that "Salomy Jane" will be heartily enjoyed by all who have the good fortune to see it.

"THE TREY O' HEARTS"

(Gold Seal-Universal—Fourteenth Chapter)

REVIEWED BY PETER MILNE

UNLESS we are decidedly misimpressed by this episode of "The Trey o' Hearts," the serial which now has only one more chapter to run, it has already begun to draw to a close, as two of the characters of the story are already out of the land of the living. It would not come as a surprise if someone told us they were dead in reality, for the fall they take accompanied by an automobile is death-defying in all the senses of the word.

Marrophet and Trine's secretary are the unlucky creatures. The latter loses control of the machine, and it plunges down



SAFE IN THE VILLAGE.

a steep hill, rolling over and over many times. The hill resembles a wall more than anything else, it is so steep. The machine is smashed to pieces, as likewise are the two villains that were in it. Marrophet shows signs of life when we see him last, but it takes a good stretch of the imagination to believe he is still alive.

Aside from this thriller, there are plenty of others to maintain the great interest that all the other installments have held. The two heroes, Alan and Barcus, and the two heroines, Rose and Judith—for the latter young lady should not be rated in the capacity of heroine as well as her more sympathetic sister—take quite a wild ride on two motorcycles over hill and dale. Alan and Rose take another tumble over the side of a hill when Law avoids a collision with the other sister, and is forced to steer over the embankment, ninety feet in height.

Great suspense is created when the same party of four crawl up a steep declivity by means of a rope. In other words, the chapter is a real thriller, holding up the high standard set by the others, exceeding some, equalling most, and only a notch behind the best.

Even though Marrophet and the secretary are, to all appearances, out of the way forever, and Trine and his evil intents are left alone in the world, the ultimate outcome of the story is still well under cover, which we will look forward to and learn next week. By the way, the temporary title has it, that the caption of this chapter is "Blankety Blank."

FIFTH ASSOCIATION BALL IN TERRACE GARDEN

THE fifth annual ball of the Motion Picture Exhibitors' Association of New York will be held at the Grand Central Palace on December 15. Great preparations are being made for this event, and it is expected that it will be the largest in the history of the Association.

The accommodations of the Palace are thirty thousand persons, and preparations are being made for the reception of this number. Last year the ball was held at the Terrace Garden. Fifteen thousand persons attended. Four floors of the Palace will be held in readiness so that everybody can have a chance of dancing and enjoying himself.

"WHAT COULD SHE DO?"

(Edison—Three Reels)

REVIEWED BY CLIFFORD H. PANGBURN

THERE are a number of points about this picture which goes to make it one that will please spectators. There is a strong story of a rather unusual sort, and there is fast action. The fight between the police and the gang of kidnapers is unusually well done and puts many thrills into the picture. There is really no place at which the interest drags.

Each of the three reels tells the adventures of a girl in three different situations. Gertrude McCoy plays the heroine in her usual pleasing style, and is supported by a large cast, which includes many of the Edison favorites. The story opens in the home of a wealthy Southerner.



THE KIDNAPPED BABY IS FOUND

He has, as he expresses it to a Northern friend, "brought his daughter up to be a lady." When he dies insolvent she faces the question of earning a living. The Northern friend of her father gives her an introduction that gets her a place as governess in his married daughter's home.

After a time she is dismissed regretfully because of her ignorance of the care and management of children. Left almost penniless she gets a place in a department store. A fellow clerk, who lives at the same boarding house, discovers that a wretch has enticed the innocent girl to a Chinese restaurant on the pretext that he can get her a good job in vaudeville, and wants to talk the matter over. She rushes to the place just in time to save her friend.

The shop girl is stealing from the firm, and being suspicious of an arrest she manages to shift the blame onto the Southern girl. She knows who is guilty, but will not betray the girl who saved her from worse than death. The police try to break her down, but fail. Finally the dishonest girl confesses. The police inspector, struck by the fine character of the heroine and her ability to keep things to herself, appoints her to a place as a woman detective.

Her first case is that of running down kidnapers who have taken the little sister of a young man who had met her in the South, but had lost trace of her. She had to take a place as maid in the house in order to get on the trail of the crooks. Finally she locates the child and with the help of its brother and the police, overcomes the gang. Then she resigns from the force to marry the young man.

"AMERICA"

(World Film—Six Reels.)

REVIEWED BY PETER MILNE

"AMERICA" as played at the New York Hippodrome last season was a tremendous success, and this picture is practically an exact reproduction of that spectacle. The scenes taken on the stage of the monster house are almost identically the same, varied now and then with a close up,

and an occasional view of the audience, in which is seated a comical "rube," who becomes greatly agitated when the chorus comes on, which puts in its appearance very often.

If this picture is presented with appropriate music, a very entertaining show will be the result. Such a gigantic, fantastical spectacle can hardly fail to make an impression, even though the songs, jokes and dialogues, which are partly responsible for the success of the stage version, are absent.

Naturally anyone who has heard of "America" will take pleasure in witnessing it as a picture, whether he has seen it presented on the stage or not, and considering that it was entirely made on the stage, a wide scope and a large variety of scenes have been obtained.

But of course regarded scenically it will not compare favorably with a picture taken out in the open when the occasion requires. It is really no more than the stage version visualized, with no great changes, which in almost any other case would result in absolute failure. But the Hippodrome shows will all lend themselves to pictures, as they are entirely different from others.

Nothing sensational occurs until the last reel, when an automobile runs wild in the Rocky Mountains and crashes into the lake in the front of the stage. This is a real thriller, and when four or five men mounted on horses plunge in after the car, one has seen something rare in this line.

The numerous performers that appeared in the production "America" all appear and go through their individual acts, which are amusing, clever, or startling, as the case may be. A fine fire scene is staged. The occupants of the house are to be seen jumping from the windows into life nets. This is very well done, and when one considers that it all was done on the stage, it is truly wonderful.

LUBIN INSTALMENT FULL OF THRILLS

THIS adventure of Lord Cecil is quite melodramatic and emphasizes the courage of the quiet Englishman. He is providentially rescued from a railroad wreck and cared for by the cashier of a construction company and nursed by the young man's sweetheart.

A few days later Cecil has the opportunity to discover and circumvent a clever robbery scheme, which probably



RESCUED FROM THE WRECK

would have wrecked the prospects and happiness of a very worthy couple. Arthur Johnson is again himself, with his cool force of character, and is equal to a dangerous situation.

REEL FELLOWS HOLD MONTHLY DINNER

Special to MOTION PICTURE NEWS

Chicago, Oct. 23.

THE Reel Fellows Club of Chicago held its monthly dinner, Wednesday evening, October 23, at the Advertising Club. A live attendance and a good cabaret made the meeting an unusually enjoyable one.

The "pep" and enthusiasm aroused in discussing the plans for the coming winter assures the motion picture organization of Chicago a most successful and profitable season.

Motion Picture News

HAS THE QUALITY CIRCULATION OF THE TRADE

MOVING PICTURE NEWS EXHIBITORS' TIMES

Published Every Week by

EXHIBITORS' TIMES, Inc.

220 West 42nd Street, New York City.

TELEPHONE BRYANT 7650

Chicago Office, 604 Schiller Building

WILLIAM A. JOHNSTON.....	President
HENRY F. SEWALL.....	Vice-President
E. KENDALL GILLETT.....	Secretary
H. ASHTON WYCKOFF.....	Treasurer
WENTWORTH TUCKER.....	Ass't Treasurer

WILLIAM A. JOHNSTON.....	Editor
LESLEY MASON.....	Managing Editor
WILLIAM RESSMAN ANDREWS.....	News Editor
H. ASHTON WYCKOFF.....	Business Manager
R. M. VANDIVERT.....	Advertising Manager
E. J. HUDSON.....	Circulation Manager
THEODORE S. MEAD.....	Chicago Manager

This publication is owned and published by Exhibitors' Times, incorporated under the laws of the State of New York. The offices and principal place of business are at 220 West 42nd Street, New York City. The address of the officers is the office of the publication.

Entered as Second-Class matter at the New York Post-Office.

Subscription \$2.00 per year, postpaid in the United States, Mexico, Hawaii, Porto Rico and the Philippine Islands. Canada, \$3.00; Foreign, \$4.00 per year.

ADVERTISING RATES ON APPLICATION.

Copy for next issue must reach us by Tuesday, 5 p. m.



Cuts and copy are received subject to the approval of the publishers and advertisements are inserted absolutely without condition expressed or implied as to what appears in the text portion of the paper.

Vol. X November 7, 1914 No. 18

The Immorality of Poor Pictures

WHEN "The Avenging Conscience" was shown in Pasadena and Los Angeles, a preliminary leader carried two paragraphs written by the director, David J. Griffith.

The first paragraph, appearing under the title, "A Plea for the Art of the Motion Pictures," is in itself an unanswerable reply to all the censorship agitation, insofar as well produced pictures are concerned.

* * *

THE leader ran:

"We do not fear censorship, for we have no wish to offend with indecencies or obscenities, but we do demand, as a right, the liberty to show the dark side of wrong that we may illuminate the bright side of virtue—the same liberty that is conceded to the art of the written word—that art to which we owe the Bible and the works of Shakespeare."

* * *

IF Mr. Griffith had never produced one of his excellent pictures he would still be the debtor of this industry for the production of this single paragraph. And again, the mind which could produce so thoughtful a bit of writing is best to be entrusted with the making of fine pictures.

"The Avenging Conscience" unfolds the conception and consummation of a murder. It is unsparingly realistic.

But so well paralleled is it with elevating, softening scenes and so happy the unexpected ending that its effect is at once artistic, strongly moral, inspiring. It is a fine production!

* * *

THE theme of a play or a book does not damn it. Just as soon as our reformers know this truth and accept it, we shall have little trouble with censored pictures.

It is rather the way of producing pictures—whatever their themes—from which we have always most to fear.

* * *

JUST recently two photo-plays were shown in New York—one portraying the demoralizing effects of the use of a drug, and the other the photo dramatization of a widely-read novel—and both, in one editorial breath, were frantically denounced by a journal of the trade.

Nothing at all is said of how these pictures were produced. The themes alone are violently assailed. Anyone who has seen the pictures will seriously doubt if the writer of the editorial in question did see them—so seriously that he will be forced to question the motive of the editorial and ask himself if it were not a commercial one.

* * *

IN all sincerity, we challenge flatly the 9,000 to the whole industry or to the public of this hypercritical and—we are forced to say—hypocritical attitude.

It is neither broad, sane, cultured nor honest.

It is unpardonably restrictive of the art of the motion picture.

* * *

AGAIN let us emphasize: the theme of a play or book or of any work of art should not damn it, but only the manner of its production. We daresay that had "Sappho" been written by a bartender, it might be a lewd book instead of one of the greatest lessons of life ever written and a triumph of literary art.

So with the works of Shakespeare, Hawthorne, Hardy, Galsworthy, Tolstoy, Hugo, Murger, George Sand, Flaubert—the list is very long.

* * *

OF the manner of picture production, there is enough to criticize—honestly—to fill each week all the editorial pages of all our picture journals. Not a day's releases go by but what there are glaring evidences of inexcusable faults in production.

The complaint of the exhibitor all over the country is against poor pictures, of which there is a wealth, not against the themes which to certain few minds seem immoral. And plenty of these poor pictures with the most exemplary themes, contain unnecessary scenes of a physically revolting character and with no excuse for their production.

* * *

BETTER pictures mean better production.

Low ideals in production—not in selection of themes—constitute the danger of the day—as concerns censorship and the prosperity of the motion picture industry.

PUBLIC TIRED OF POOR PICTURES

Special to MOTION PICTURE NEWS

Los Angeles, Oct. 20.

"Manufacturers, exchange men and exhibitors are all to blame if the motion picture business is suffering from lack of patronage, because all have had a part in allowing the public to be humbugged with poor pictures, which were played up, widely advertised and fell flat," is the belief of E. H. Emmick, manager of the Los Angeles branch of the Golden Gate Film Exchange, Inc.

"Good productions pull bigger crowds the longer they are shown—that is, until all amusement loving people of a given field see the picture. On the other hand, the exhibitor who shows one of the so-called features, the exchange man who rents one, or the producer who sells it injures his future patronage and business.

"The trade regulates the price of film and rentals by the quality, and the exhibitor must ultimately do likewise. If he has a five-cent house he cannot afford to show ten, fifteen or twenty-cent programs, and vice versa. Exhibitors of every locality should regulate such conditions by co-operation with the exchange men and through co-operative organizations."

NINETY-FOOT MOTORCYCLE PLUNGE IN "HEARTS"

Accompanied by a truck load of paraphernalia and the physician who always goes with them on their trips from the studio grounds, the Gold Seal company, under the direction of Wilfred Lucas, has left for San Gabriel Canyon in the heart of the Sierras, where are to be staged the greater part of the scenes in the fourteenth installment of "Trey o' Hearts" series.

Thrilling as have been the sensational escapes from death in the preceding chapters, there is small doubt but that the present installment offers more opportunity for disaster than any that have gone before.

Pursued over the mountain road along the rocky canyons by a racing car bearing Marrophi and a companion, George Larkin and Miss Madison, to escape them, ride their motor-cycle over the edge of the road and down a 90-foot embankment at a point regarded by autoists as the most dangerous spot along its tortuous way.

Needless to say, this scene will not be rehearsed.

"NEPTUNE'S DAUGHTER" BREAKS RECORD

Special to MOTION PICTURE NEWS

Wilkes-Barre, Pa., Oct. 28.

"Neptune's Daughter" played to record-breaking crowds at the Savoy Theatre, this city, for the first three days recently. It is thought that "Neptune's Daughter" attracted more people than any other picture that has played this city for the same period.

Hartford Theatre Takes Rank With Best

Strand, a Monument to the Architect's Knowledge of the Needs of the Public, A Fitting Edifice for Film Drama

Special to MOTION PICTURE NEWS

Hartford, Conn., Oct. 28.

THE Strand Theatre, which opened in Hartford, Conn., at the beginning of the season, has attracted a great deal of attention on account of its handsome appointments and comfortable seating arrangement.

The impression gained from the decorations and color scheme is first of size and light, a vast spaciousness that is both unusual and refreshing in a theatre of any sort, and is due to its height, the absence of stage boxes and orchestra pit. From the entrance into the lobby to the last detail of the new theatre there are unusual and beautiful details of decoration and arrangement.

The lobby has yellow walls above a wainscoting of blue-gray marble and floors of gray and white tiling. The mirrors are in the form of windows, framed

and divided into small panes by Circasian walnut. Potted trees and branches of oak are used in decorating.

The general color scheme of the interior is yellow and deep blue, combined with soft pastel tones and a deep warm brown. The side walls are of rough plaster, tinted deep yellow, divided into panels by flat pilasters of oyster white and gold, with capitals of classical motif, matching the trimmings throughout, which use the familiar egg and dart, the acanthus leaf and laurel wreath.

These narrow panels are decorated with a stencilled design of Pompeian motif in soft, flat shades of blue, dull rose, pale green, brown and white. Between the panels and ceiling the egg and dart molding is used, and the frieze above is in shades of blue in a large design.

"Shore Acres" Acted by Broadway Cast

C. A. Stevenson, Conway Tearle and William Riley Hatch Prominent in Coming All-Star Alco Release, Based on Herne Classic

"SHORE ACRES," the five-reel feature of the All-Star Feature Corporation, released by the Alco Film Corporation, on October 26, is enacted by a cast well known on Broadway.

The work of Charles A. Stevenson has been known to theatregoers for years. In "Shore Acres" he appears to the moving picture world for the second time. His initial appearance was in the support of Ethel Barrymore in "The Nightingale." Conway Tearle, another Broadway favorite, was with Mr. Stevenson in "The Nightingale," and is now in "Shore Acres." Mr. Stevenson plays Nat Berry and Mr. Tearle Sam Warner.

Other players in this film adaptation of the original James A. Harne classic are: William Riley Hatch, Violet Horner, E. J. Connolly, Harry Knowles, Gladys Fairbanks, Philip Trout and

Madge Evans, a cast of even quality

One of the most effective scenes in which Messrs. Stevenson, Tearle and Hatch appear with Miss Horner is that within the lighthouse. In the legitimate theatre patrons held their breath while the brothers Nat and Martin Berry struggled for the mastery of the lighthouse, and the gun which was the key to the situation, for upon the outcome depended the lives of Sam Warner and Helen Berry.

The lovers were out in a small boat close to the reefs. Only the warning light could save them, and the lantern was dark.

In the Thomas production this scene is shown with all the realism of a real storm since the flashes back to the young people in the boat were made off the coast of Maine during a tempest.

Releases of New Company Include Animal Films

Supreme Feature Corporation, Incorporated at \$50,000, the Latest Addition to Los Angeles' Long List of Producers

Special to MOTION PICTURE NEWS

Los Angeles, Oct. 26.

SUPREME Feature Corporation is the recent organization perfected by O. V. Traggardh, of Los Angeles and San Francisco, for the marketing of films on the states right plan.

The new company is capitalized at \$50,000 and will in the near future announce its first releases, which will include two animal pictures, "The Beasts of the Jungle," a two-reel educational picture, and "The Jungle Cure; or, Frightened into Sobriety," an animal comedy, both produced by the E. & R. Jungle Film Company of Los Angeles.

O. V. Traggardh, who is president

of the Union Film and Supply Company, with exchanges in this city and San Francisco, has been chosen as president; G. E. Chamberlain, president of the Independent Film Exchanges, vice-president; Charles Stillwell, of the Silver Palace theatre, San Francisco, is secretary and treasurer. These officers and C. Mowe and S. McClure form the board of directors.

The home office of the company will be in San Francisco, with a show room in New York City. It is the intention to do all manufacturing in California and films will be shipped direct from the company's laboratory to buyers anywhere in the country.

"THE TENTH COMMANDMENT"

(Imp-Universal—Three Reels)

REVIEWED BY PETER MILNE

ONE is led to believe from the outset of this production, that it is to be a picturization of the disagreeable Long Island murder which stirred the public not so long ago. It is a great and pleasing surprise, when after the picture is well under way, that matters take an entirely different turn and finally end in a somewhat pathetic but satisfactory manner.

The tenth commandment, "Thou Shalt Not Covet Thy Neighbor's Wife," is the forceful foundation of the story.

Being blessed with such a title the picture seems to command more respect and to be elevated from the ordinary society drama, with which, otherwise, the production might be classed. Then, too, Herbert Brennon, the director, has taken great care with the development of the story; each scene leads a step further to the quite unexpected and sad climax.

Perhaps the only fault is that point which is directly responsible for this climax, that is the remarkable fierceness of the conflagration, in the midst of which the doctor and his nurse are operating on a child, whose life hangs in the balance. This point might be changed, the appearance given that the flames are more subdued, as it is beyond the imagination to conceive that three people are in the building.

The doctor manages to finish the operation and escape with the child, but the nurse perishes in the flames, thus proving her undying love for the doctor and his wife, who becoming jealous had previously separated from her husband.

William Shay plays the doctor, Ruth Donnelly, his wife, Violet Mercereau, the nurse, William Welsh, the "other" man, and Hobart Henly, the wife's brother. They all appear at their best.

"THE SEA NYMPHS"

(Keystone-Mutual—Two Reels)

REVIEWED BY PETER MILNE

THIS is the second of the two a month Keystone two-reelers, and features Roscoe Arbuckle and Mabel Normand. Whenever these two appear hearty laughter is sure to be the result, and so it will be here. The picture was filmed partly on the way to the Santa Catalina Islands and partly on them; the result is that some very beautiful scenes have been obtained which form a very desirable background to the farce.

Incidentally the picture presents a fine opportunity for Miss Normand to display how well at home she is in the water, what a good diver she is, and several other things which will be observed when the picture is shown with the young lady in a one piece bathing suit.

Then we have Fatty—not in a one piece suit by any means—but in a garment that seems several times too large for him, impossible as that may seem. He will call for rounds of laughter when he attempts to emulate his more graceful partner in the art of fancy diving.

A great part of the action takes place in the water, and when two of the best comedians start performing in the ocean for the camera there are not many funnier things. Like the first of the two reelers, "Dough and Dynamite," this one is bound to be a success. It just can't help it.

PRESIDENT PEARCE AT WASHINGTON BALL

PRESIDENT MARION S. PEARCE, together with all the officers of the Maryland branch of the Motion Picture Exhibitors' League of America, go to Washington to attend the motion picture players' ball to be held at the Capitol.

In addition to the officers a large number of Baltimore exhibitors, exchange men and operators will attend. The Baltimore contingent motor over in a private car with President Pearce and a party, together with the national vice-president, J. Howard Bennett, and party.

"BEHIND THE SCENES"

(Famous Players-Paramount—Five Reels)

REVIEWED BY H. S. FULD

WHEN one goes to see Mary Pickford in one of her inimitable characterizations, he expects to witness something out of the ordinary in the general run of films. In the role of the little actress in "Behind the Scenes" little Mary renders one of the best portrayals of her brilliant career.

To say that she acts the part to the life would no doubt sound trite and unconvincing, and yet in no other way can we express our unbounded admiration. It really seems uncanny to sit and watch the different emotions, such as joy, anger, embarrassment in endless variety depicted on her face, and then to come back to earth, as it were, with the realization that it is only acting.

Of the story, by Margaret Mayo, author of "Baby Mine" and "Twin Beds," it might be said that it is particularly adapted for the screen judging by the way it is produced by the Famous Players Company.

The entire absence of so-called padding, the smoothness with which the scenes follow one another, the special attention which has been given the smallest detail, the pains taken by



AFTER MANY CURTAIN CALLS

the producers to make the theatre scenes appear "real"; all this taken with the wonderful acting of Miss Pickford makes "Behind the Scenes" a masterpiece. The producer has shown exceptional ability.

James Kirkwood, who played the part of Steve Hunter, husband of Dolly Lane (Mary Pickford) directed the piece, and he is to be complimented on both his acting and his directing.

Dolly Lane, after a struggle between love and ambition yields to the pleadings of Steve Hunter, surrenders her career and goes West. Later, tiring of the quiet farm and Steve's seeming neglect of her for his work, she revolts and returns to the city. Through the illness of a star, Dolly gets her chance, and in trying to forget Steve throws her heart and soul in her work with the result that she is soon the sensation of the theatrical world. She has everybody at her feet.

But success, without Steve to share it, turns to ashes, and when one night the wealthy producer of her play makes advances to her she sees a new light. Despairing and disillusioned, Dolly resigns from the cast and takes the first train West.

In the golden harvest fields, on a sunshiny day, she again meets Steve and tells him all, and as his forgiving arms embrace her the tawdry glitter of the tinselled past is forgotten and the real drama of life unfolds before them.

Lowell Sherman in the part of Teddy Harrington, Steve's friend, deserves special mention, as do Ida Waterman in the role of Mrs. Harrington and Russel Basset as Joe Canby, the wealthy man-about-town.

There is no reason why "Behind the Scenes" should not take its place as the best Mary Pickford release we have had the pleasure of seeing for some time.

"THE MYSTERY OF EDWIN DROOD"

(World Film—Five Reels)

REVIEWED BY PETER MILNE

THE World Film Corporation has already shown what it can do with one of Charles Dickens' stories, in putting it on the film, as was seen in "The Chimes." "The Mystery of Edwin Drood," the second picture adapted from Dickens, is every bit as good as its predecessor.

Only about half the story is the work of Dickens, as before he had time to finish it he died. The supplement that appears in the picture is the work of Tom Terriss, who also stars in the picture. His solution of the story, which as it stood in its unfinished state, was certainly a mystery, is generally considered more like the ending that we would have supposed Dickens would have written than any other.

The entire story, the work of Dickens, and then again the work of Mr. Terriss, lends itself to screen adaptation remarkably well. The mysterious disappearance of Edwin Drood, coming as it does just when the spectator has gained interest in the picture, will not allow the attention to falter until the very end, when the real culprit is apprehended.

Mr. Terriss, who also assisted Mr. Blache in the direction of the production, appears at his best in the role of John Jasper, who it develops is the real criminal of the tale. Rodney Hickock plays the part of Drood, and Paul Sterling appears as Neville Landless. Vinnie Burns is seen as Rosa Budd; and Helen Landless, who is the one that apprehends Jasper, is played by Margaret Prussing. Faye Cusick appears as the woman whom Jasper has ruined.

The costuming and settings have been carefully arranged; never a moment is the correct period neglected. An instance which seems rather small, but which in reality lends a fine atmosphere to the picture, is the fact that in the street scenes a number of people are seen moving about in the background, or passing the principals.

Very often in pictures the principals are seen supposedly conversing on a busy thoroughfare, but no other people are seen in the scene. That this point is not neglected here shows what attention has been paid to small details which escape the mind of a less skilled director.

The fire scene in the last reel is a fine one; it gains headway with startling rapidity, but it's a thriller nevertheless, and brings the picture to a very good close. "The Mystery of Edwin Drood" will surely be appreciated by all, more especially by those who are familiar with Dickens; but those who have never read any of his works will enjoy it, as the story presented is one of the best, made to entertain; and it certainly accomplishes its mission.

WOMAN SEES MISSING BROTHER ON SCREEN*Special to MOTION PICTURE NEWS*

Jackson, Miss., Oct. 26.

A WOMAN'S scream, followed by the exclamation, "That's my brother," startled patrons of the New Majestic theatre at Jackson, Miss., recently, while one of the Kalem films was being thrown on the screen.

Investigation followed, and Manager Bowers found Emma Manning, member of a prominent Jackson family, in a high state of excitement. She insisted that one of the leading characters in the film production was Harris Manning, her brother, who had not been heard from by the family for two years.

Several intimate friends of Harris Manning were sent for, and when this reel was again reached in the production they were equally positive that it was the man.

Harris Manning left Jackson shortly after the death of his sister, Mrs. John Mosal, returning to California, where he had resided for several years. Always irregular about notifying his family as to his whereabouts, he had not written to them in a long time.

Several weeks ago he was seen in Atlanta at the Piedmont Inn by a friend. The family endeavored to locate him by this clue, but were unsuccessful.

Miss Manning immediately on leaving the theatre telegraphed to Kalem people, and the investigation which followed resulted in the locating of the missing brother.

"THE OPENED SHUTTERS"

(Gold Seal-Universal—Four Reels)

REVIEWED BY PETER MILNE

"THE Opened Shutters" has for its theme the sentiment, than which no truer words were ever spoken, "As a Man Thinketh, So Is He." It has been elaborated and developed to such an extent both by the author, Clara Louise Burnham, and the director, Otis Turner, that a forcible and telling picture has been presented; one which will cause its witnesses to think.

Hardly no better company could have been chosen to interpret the leading roles than Otis Turner's Rex players. This merit will be better understood when it is said that the film relies solely on its sentiment and the development of it, for the grip that it takes and retains on the spectator.

Sensationalism and rapid action are entirely lacking, and they will not be missed. So that being a picture of this sort, its success really depends on the ability of the leading players in the cast.

William Worthington plays the part of "Thinkright" Johnson in a manner that is worthy of the good name he has created for himself. His part, which might be called that of a perfect man, suits his particular characteristics remarkably well. Frank Lloyd, as Judge Calvin Trent, and Cora Drew, as Martha Lacey, both people who have a decidedly warped idea of human nature, and it is satisfactory, indeed, when, toward the end, it develops that they have learned to "think right," as the picture expresses it. Betty Shade, as Edna Derwent, has a smaller role. She is thinking right at the start of the story and keeps it up in fine style to the end.

Anna Little and Herbert Rawlinson are the lovers in the picture, but the love story is only prominent toward the end.



TAKEN TO A HOME.

Anna Little takes the part of an orphan girl, weak and jealous in nature, but who, also, finally learns to think right. Rawlinson is just a plain man, and plays his part well.

The Opened Shutters refer in reality to the shutters of an old mill, which, by the way, is the center of a beautiful rural scene. At the close of the story its shutters are opened, and the happy lovers, whose eyes, too, have been opened to the world in general, are seen behind the window, with "Thinkright" beaming benevolently on the outcome of his goodness.

CRAFT'S RIGHTS TO EACO FILMS BRINGS CONGRATULATIONS

P. P. Craft, general manager of the Strand Film Company, is in receipt of many telegrams of congratulations upon his securing the exclusive American rights for the Eaco Films, Inc., in which Edwin August will be starred.

It is the intention of Mr. Craft to release an Edwin August feature every other week, and a one-reel comedy and single-reel dramatic subject every week. All of the Eaco productions will be under the personal supervision of Mr. August.

"THE PERFECT THIRTY-SIX"

(Pathé—Four Reels)

REVIEWED BY CLIFFORD PANGBURN

ON the stage comedies "with a laugh in every line" exist chiefly in the minds of press agents. So far as lengthy productions are concerned their silent counterpart is ever more rare. Here, however, is a four reel picture which is funny from start to finish, and that without any flapstick stuff.

As may be imagined from this fact, it is a film which any audience would regard as a treat. Not only is the story and the acting hilarious, but a series of humorous subtitles written by Montague Glass, on whose story of the same name the picture is based, adds an unusual effect. These subtitles contain bits of wisdom supposed to be contributed by an old hand in the "cloak'n-suit" business.

The film was made in Berlin, and it strikes a death blow at any theory anent a lack of a sense of humor among the



LEARNING THE HIGH LIFE WALK

Germans. The principal characters are "the perfect thirty-six," the senior partner in a cloak and suit firm and his three associates, one of them being a star salesman and another a sort of simpleton. These five parts are all acted in inimitable style by players who make the fullest use of the many opportunities for fun offered by the story.

The settings are of unusual excellence, and are elaborate when necessary. For example, the scenes in the sales rooms of the gown merchants show an establishment which equals any smart atelier along Fifth avenue. The outdoor backgrounds show glimpses of Berlin streets. The photography is as good as the other features of the production.

The story concerns a girl who goes to work in a small dressmaking shop. A salesman from a big Berlin house sees her, and decides that she is the model his firm is looking for, "a perfect thirty-six."

As she longs for the gay life of the city he has little trouble persuading her to accept the new job. In the city she makes a hit with all of the partners and soon has them dancing attendance to her wishes.

When a princess comes to look at gowns it is the new model who is responsible for a large order. The senior partner finally marries her to keep her with the firm, as she has been offered double her salary elsewhere.

CARYL S. FLEMING IS SERIOUSLY INJURED

Caryl S. Fleming, juvenile leading man of the Pierrot Film Company, was severely injured in an automobile accident recently. Mr. Fleming and a number of actors and directors of the company were departing from the studio near Tappan, New York, in an automobile to visit a sick member of the company, when another car crashed into the rear of the one in which was Mr. Fleming.

The actor's injuries were found to be serious and he was taken to his mother's home at 264 Riverside Drive, New York, where he is at the present time. Mr. Fleming is a member of the Screen Club, and both popular and prominent in motion picture circles.

"THE TEMPTATIONS OF SATAN"

(Warner's—Five Parts)

REVIEWED BY PETER MILNE

THERE is a distinct line between morality plays or pictures that fulfill their purpose, that is, teach a lesson, and those that the producers attempt to shield by asserting that they are morally necessary, when in reality they are so much trash. Such pictures, it should not be necessary to add, are the bane of the business.

This picture makes no attempt to visualize what an innocent boy or girl, let loose in a great city, should or should not do. It merely shows what might happen to the average young person when surrounded by circumstances of an evil and at the same time attractive nature. And although sorely tempted, it gives one great pleasure to see the principals pass through their many adventures none the worse for the experience.

Everyboy and Everygirl are the characters with whom we are most concerned. They were created as personifications of the average boy and the average girl, and the characterization that Joseph Levering and Vinnie Burns give to these parts is not in any way exaggerated as is the case nine out of ten times in pictures that profess to be of a similar nature and usually are not.

The story woven about the two young people is one of great interest, nothing unusual, but always absorbing. During the latter part of the picture the story becomes so entertaining that we are liable to forget the fact that they are personifications, but this fact is only forgotten at times.

Credit may be accorded the rest of the cast, of which James O'Neill is the most important. He embodies the popular idea of Satan and is constantly changing from one character to another, but in all of the parts he retains the same evil countenance which stamps him always as Satan. Fraunie Fraunholz appears as Justice in the role of a detective, and the part of Avarice is carried off by Mr. Morton, who assumes the guise of a factory boss.



EVERYGIRL SINGS IN THE CAFE

Herbert Blache directed the production, and aside from a few inconsistencies has done excellent work. When Everygirl lets go of the end of a rope and falls to the ground, she drops only a few feet, yet the fall completely unbalances her mentally.

It might have been a little better if the fall had been made to appear longer, and the subsequent losing of her mind would have appeared justified. This is not a serious fault, and is so overshadowed by the rest of the picture's merits that it comes near being totally eclipsed and has little or no bearing on the picture's power.

There is sufficient action throughout to keep the interest at the highest point. A fine fight is staged in a cafe, and a good fire scene comes near the end of the picture. All in all, "The Temptations of Satan" will please and not offend. The picture is released under the brand of the U. S. Amusement Company.

Live News of the Week

George A. Stevenson, for ten years owner and editor of the Chicago *Weekly Amusement Guide*, and later advertising manager of another theatrical paper in New York City, and now in charge of the publicity of the London Trans-Atlantic Film Company, writes to friends in New York City that business in the United Kingdom is, according to the present British slogan, "as usual." He declares that he is as busy as he ever was in the States.

Charles Brabin, Edison director, in making a fire scene for the first of the "Young Lord Stranleigh" series, "The King's Move in the City," selected Columbus Day for the undertaking. The crowd that gathered, and which Mr. Brabin took advantage of, by placing them in the field of the camera, created the best atmosphere possible, and hereafter Mr. Brabin will try to film his fire scenes on a holiday.

Samples of the paper for the California Motion Picture Corporation's first release, "Salomy Jane," have been received at the New York offices of the Alco Film Corporation. They are from designs by Charles Peters and are in six colors. The work is being done in San Francisco.

Popular Plays and Players, Inc., which releases through Alco, has started work on the picture scheduled to follow "Michael Strogoff." Neither the nature of the production nor the title has been announced.

Reviewers, exhibitors and buyers who flourish in New York City are sighing quite some sighs of relief these days, for they have found the projection room de luxe. This place is situated at 126 West Forty-sixth street, where the Kinetophote has just introduced a goodly number of the aforesaid gentlemen to about forty willow chairs in which to lounge while passing judgment on Kinetophote features.

Carlton King, Edison comedian and character man, is one of the greatest make-up artists in the motion picture field. He is able to portray the most difficult character in the funniest comedy or the most serious drama. Recently he assumed the role of a tramp, and between takes went home to dinner. It is said that his mother mistook him for a real Knight of Road and chased him from the house with a broom.

Will Sheerer, now character man of the Eclair stock company, has been connected with theatricals for twenty-three years, and has only missed two seasons. The Spanish-American War and a year in Wall Street were the causes of his absence from the stage.

He has played frequently in vaudeville, and was always acknowledged as a master of make-up. Four years ago,

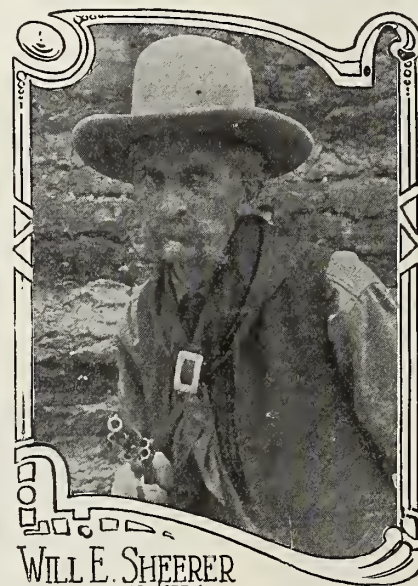

Mr. Sheerer joined the Edison company, and from there went to the Vitagraph company. Later he played character leads for the Bison, Nestor, Reliance and Crystal companies, and from the latter concern went to Eclair, where he has been ever since.

The Pastime Amusement Company, of Charleston, S. C., announces the installation of a Wurlitzer concert piano-orchestra in the Majestic Theatre. This is said to be the only instrument of this kind in use in this section of the country.

W. S. Scofield sailed recently for Europe. He will handle the Alliance program on the other side. Mr. Scofield is one of the live wires in the film business, and the news of his association with a company of the importance of the Alliance will be received with pleasure by his friends here and abroad.

Don Meany, formerly of the Essanay company, recently arrived at the Universay West Coast studios with his wife, and has taken over the publicity

of that branch of the concern. Anything that may be desired in the way of big stories or features will be in charge of Mr. Meany.

Mary Fuller, of the Universal company, is enshrouded in deep gloom just now, as her dear little dog, Toby, has passed away. And it was all due to a vile hotel clerk not allowing the canine to pass the night under the same roof with his mistress.

Editor George Hall, of the Eastern staff of the Universal scenario department, is exceedingly busy these days. He and his assistants are selecting some of the best stories of prominent authors, and adapting them to the screen.

With Arthur S. Dickinson as manager, the Alcazar, the newest motion picture theatre at Chattanooga, Tenn., has just been opened to the public. Patrons are lavish in their praise of the Alcazar.

The United Theatrical Enterprises, Inc., owners of the Elmwood, Allendale, Colonial and Keith's theatres in Buffalo, N. Y., has opened its new offices at 504 Iroquois Building. Heretofore the members of this company have had separate offices in different parts of the downtown section.

The Family Theatre, Buffalo, N. Y., has changed management, and the policies of that house are being guided by E. C. Long.

There has been a big change in Buffalo music circles recently. Herman E. Schultz, for the past four years conductor of Shea's Theatre orchestra, has resigned. Joseph Ball, of the Iroquois hotel orchestra, took the place made vacant by Mr. Schultz, while Walter Raszeja, first violinist under Mr. Schultz's direction, became director of Shea's Hippodrome orchestra, succeeding George A. Bouchard, who will remain as organist.

A new company, under the name of All Theatres Film and Accessory Company, Inc., has opened offices at 18-19 Chapin Block, Buffalo, N. Y., where, under the management of S. S. Webster, former manager of the Globe Theatre, the Alliance features will be booked for local territory. Among the films now on hand are "The Key to Yesterday," "The Path Forbidden," and "At the Old Crossroads." The capital of the company is announced at \$75,000.

Mr. and Mrs. Reaves Eason of the American studios recently chaperoned a merry crowd on a barbeque and beach party at Hope Ranch Beach. Among those who went along and enjoyed themselves were: Miss Marty Martin, Miss Perkins, Miss Kroman of Tacoma, Wash., Arthur Millets and Mr. Tedmarsh.

After William Grawood had put in some strenuous work in the American production "In the Candlelight," he ran down to Los Angeles for a "rest" and a good time. Mr. Garwood loves Santa Barbara, but there are times when the bright lights of Los Angeles are strong attractions.

The offices of the Dragon Features have been removed from 110 West Fortieth street to 1600 Broadway, New York City.

In Thomas H. Ince's picture, "A Cross in the Desert," which he has just completed, Walter Edwards, character man of the New York Motion Picture Company, has been given an excellent chance to display his ability. He plays the part of a veteran hobo, and every move proclaims him a master of character artistry.

Edith Taliaferro, who is to appear in several Lasky productions, has appeared in productions of James H. Stoddard, Olga Nethersole, Sothern and Marlowe, and played the part of Meine with the elder Thomas Jefferson in "Rip Van Winkle."

Just what play Miss Taliaferro will appear in for the Lasky Feature Play Company has not been announced, but she left recently for Los Angeles to begin work immediately, under the direction of Cecil B. De Mille and Wilfred Buckland.

The Dyreda Art Film Corporation has contracted with Lewis J. Selznick, general manager of the World Film Corporation, whereby all the features manufactured at the Dyreda studios are to be distributed through the World Film Corporation.

The first picture to be released, November 16, under this arrangement, is "One of the Millions," featuring Laura Sawyer.

Beverly Bayne, who often plays opposite Francis Bushman in the Essanay pictures, recently appeared in person at a theatre in Joliet, Ill., and completely captured the hearts of the attending audience.

A forthcoming Selig release is based on James Whitcomb Riley's poem, "The Old Swimmin' Hole." In the prologue the noted poet himself appears. The screen version was written by William E. Wing.

MAKING LOCAL FILMS NEAR THE EQUATOR

(Continued from page 24.)

tion so that the positive may remain soft and with non-curling qualities.

If not stained, the positives after washing must be dipped into the glycerine bath: Sixteen ounces of glycerine to 1,000 ounces of clear water, dirtless, for five minutes, to save curling.

Making the Titles

After having cleaned the positive as you did with the negative on the celluloid side, arrange the patching more carefully, as same must stand the pulling of the projector sprockets.

The titles are easily done, either by hand or copying them from regular typographic proofs.

By hand, you can use any alphabet like those used by advertising shops with common rubber types, of course of one inch or more in height. Print the title on white paper, and by cutting out any advertisement full page border, like that used by the Famous Players Company, you will have a good title film.

If from printed type, have the printer make you the proofs upside down, so that the reading appears turned and not as common type.

That is easily done by printing the reading matter on the pressing bed of the printing machine and by setting afterwards direct on top of that printed matter a sheet of lustrous paper and print against the same bed.

Thus, you will have on one side the correct reading and on the other side the turned printed reading from which you will copy the title film.

Titles Stained

Fix the camera with a positive film inside; have your lens stopped to f/16 and run the handle about one turn per second, which will give you nice, white letters against a dark background.

When copying from your home-made titles you must remember that when inserting the said titles into the positive you must do so that the gelatine side of the film title is with the celluloid side of the positive, so that it would not appear turned when projecting same.

Titles can be developed just the same as film pictures, and stained just as well.

Do not forget to have eight feet of spoiled celluloid film, either developed

or not, but with no pictures on it, to be used: four feet on either end, as film tails, for those tails will save the damages of the projector sprockets when winding or unwinding the film.

If printing the positive film with a special step printer, follow the directions of same, but you need for such work a dark room, as the positive film is not hidden from the light. There are in the market many printers, from one hundred dollars up, but it has not been my aim to recommend an expensive outfit, but a self-printing outfit which will do as good work as I have done with the same kind of machine.

Using a Step Printer Crank

I did one trick with my camera, using the step printer crank. I made ready and focused a white paper so that the focusing size would not be larger than needed.

My camera had the lense stopped to f/22 with a positive film. I began to photograph the common paper eight or ten turns, then I painted on the white paper the letter M, turned the crank twice, painted following the M the letter A and turned again the handle twice, and so on with each letter until I completed a title, "Made by Cespedes" which, when run through the projector, made a big success as the letters appeared one after the other, thus forming the complete title.

It is a question of studying the camera and one's outfit.

Now, then, if 'way down in this tropical country I have been able to do this, why can you not do as I have done?

Buying for Cash and on Credit

You have factories that will credit you with the outfits, or give you a low discount. You have supply houses that may furnish film stock at any time, and I have to pay cash and wait one month to get my order.

You have many every-day events to film; I lack them, though I consider that all picture making I have done has repaid me well, either through my own exhibition or by showing the film on a percentage basis.

Besides, your own use of the films you make, you can perhaps send the negatives to the film weeklies.

O. E. Goebel, president of the St. Louis Motion Picture Company, has been visiting the studio of that concern at Santa Paula, California.

Tali Esen Morgan, widely known as the director and manager of the great auditorium at Ocean Grove, N. J., has been appointed resident director and manager of the Paramount Theatre at Broad and Hill streets, Newark, N. J. The theatre is being equipped with new leather folding opera chairs, which supersede the old wooden seats. A new \$15,000 organ will soon be installed.

Charles Hayden is now a member of the Oz Film Manufacturing Company at its studios in Hollywood, Cal. For the past five years Mr. Hayden has been active in the motion picture business. He was at one time a member of the Edison company; his most recent appearance was as the cook in "The Sea Wolf." He was also director with the Bosworth and Kinemacolor companies.

Previous to his motion picture work Mr. Hayden played in a number of William A. Brady's attractions and was also with Frohman in stock for a number of years.

INTERESTING FILM REVIEWS

PRODUCTIONS FROM ALL PROGRAMS

GENERAL FILM PROGRAM

"The Mill of Life." (Vitagraph. Thurs., Oct. 22.)—The junior partner in a mill tries to win over a mill girl from her husband. He discharges the man and gets him a place in another country. Then he intercepts his letters to his wife. The husband returns in time to prevent his wife from committing suicide through despondency. The junior partner is denounced and turned out of the firm. A rather good melodrama.

"They Called It 'Baby.'" (Biograph. Thurs., Oct. 22.)—On the same reel with "His Loving Spouse." An entertaining comedy concerning some Indians, a puppy and others.

"His Loving Spouse." (Biograph. Thurs., Oct. 22.)—On the same reel with "They Called It 'Baby.'" A comedy dealing with domestic infelicity.

"The Hopeless Game." (Lubin. Two reels. Wed., Oct. 21.)—A professional gambler falls in love with a fine girl and agrees to become honest. Being out of funds he takes up gambling, but quits and gives all of his money to the widow of a man who was killed in a fight at his place. The girl hearing of her lover's fall, marries a fortune hunter who goes through her money and becomes a gambler. The reformed gambler comes to her aid and marries her after her worthless husband commits suicide. In the cast are Rosemary Theby, Brinsley Shaw and Harry Roser.

"Her Mother Was a Lady." (Lubin. Two reels. Thurs., Oct. 22.)—A melodrama in which a young man whose mother is a social leader falls in love with a waitress at a lunch counter. He nearly loses her through his mother's opposition, but is finally married at the counter by a minister who is there for his lunch. There are several exciting scenes. In the cast are John Ince, Margaret Dawson, Mary Keane, Harold Moffitt and Doris Heywood.

"Under False Colors." (Vitagraph. Wed., Oct. 21.)—A maid meets a private in the army who poses as a lieutenant while she pretends to be wealthy. Later he inherits a fortune and marries her. Both are then received by persons who formerly considered them beneath notice. Nora Talmadge and Antonio Moreno head the cast.

"The Cave Dwellers." (Vitagraph. Mon., Oct. 26.)—A comedy of a fairly original nature. It is not what one would suppose from the name. There is some good photography.

"The Butterfly." (Vitagraph. Two reels. Tues., Oct. 27.)—A rather entertaining comedy, but one which hardly needs two reels for the telling. It is well acted and has several unusual effects.

"Love and Title." (Lubin. Tues., Oct. 27.)—On the same reel with "She Married for Love." A short comedy in which a foreign count wins out and marries the heiress. Fairly entertaining. In the cast are James Levering, Mabel Paige and Vincent De Pascale.

"She Married for Love." (Lubin. Tues., Oct. 27.)—A girl succeeds in getting the deacon's ardent consent to breaking his engagement to her by learning acrobatic tricks and doing a few of them at rather inopportune times for the gentleman's dignity. Some good comedy. On the same reel with "Love and a Title." In the cast are Eva Ball, Pasquiline De Voe, Raymond McKee, Harry Lorraine and Mae Sheppard.

"Slippery Slim and the Impersonator." (Essanay. Thurs., Nov. 5.)—A Slippery Slim comedy, in which Mustang Pete steals a diamond ring that Slippery Slim had bought for Sophie, and thereby wins her. But Slippery Slim, through the aid of a female impersonator from the local opera house, disgraces

Mustang Pete in the eyes of Sophie, and regains the ring and her affections.

"Broncho Billy's Mission." (Essanay. Sat., Nov. 7.)—A city girl turns over a new leaf, leaves for the West and marries the minister in a small Western town. They befriend Broncho Billy when he is wounded and escaping from a posse. Broncho Billy, in turn, delivers the girl from the persecutions of a man who had known her in her past life. A good Western story, well played by the regular Broncho Billy cast.

"A Moment of Madness." (Edison. Sat., Nov. 7.)—A girl meets the fiancée of her chum, and falls in love with him. She allows herself to brood over the matter until she attempts to kill her friend. Instead she is drowned herself. In the cast are Gertrude McCoy, Katherine Jordan, Mabel Dwight and Edward Earle.

"Sweedie, the Trouble Maker." (Essanay. Mon., Nov. 9.)—Sweedie puts one over her family by disguising her unpopular suitor as an actor and marrying him before his identity is discovered. A free for all fight follows, in which Ben Turpin and his six acrobatic policemen add to the comedy.

"Within Three Hundred Pages." (Essanay. Tues., Nov. 10.)—A detective drama adapted from the Munsey Magazines. Spider, a young reporter solves the mystery of a stolen Chinese necklace and foils Ho Fing Tang's clever plot to get it back to China. An interesting story well acted by Richard C. Traver, Rapley Holmes, and Bryant Washburn.

"Three Boiled Down Fables." (Essanay. Wed., Nov. 11.)—Three very clever George Ade fables dealing respectively with (1) The household comedian, who, as a husband, becomes an unbearable bore; (2) The lady-killing store clerk, who does not like to have customers but into his social engagements; (3) The prevailing craze for the new dances, which induces the village constable to pay the pretty dancing teacher for a lesson, rather than fining her for speeding at a mile-a-minute clip.

"Broncho Billy's Decision." (Essanay. Sat., Nov. 14.)—Broncho Billy is sent to oust an old settler and his daughter from their cabin, which stands in the right of way of the Montana-Idaho Railway. He falls in love with the daughter and refuses to press matters.

"The Ranger's Romance." (Selig. Tues., Nov. 10.)—A western drama by Tom Mix, featuring an exciting running fight between a prairie schooner and a band of drink-maddened Indians. Going at a terrific speed, one of the wheels of the prairie schooner comes off, hurling the heavy wagon and its occupants to the ground. After a brief defense, the Indians capture the girl, but she is later retaken by the ranger and his band.

"Peggy of Primrose Lane." Selig. Wed., Nov. 11.)—A drama by Maibelle Heikes Justice, dealing with the "well-known" hardships of a country girl, attracted to the city by the glamor of the stage. Per schedule, the country lover arrives on the scene in the midst of her misfortune and carries her back to become his bride.

"Cupid Turns the Tables." (Selig. Fri., Nov. 13.)—A farce comedy, in which a much-sought-after widow disguises herself as an old maid to escape the attentions of her admirers. While so disguised, she is rescued from a runaway by a wealthy woman-hater. The plot clears and, of course, they fall in love.

"The Fatal Note." (Selig. Sat., Nov. 14.)—A comedy drama hinging around an old note sent by a Confederate officer to his sweetheart. After they have been married five years, he fails to recognize this note, which he sees his wife passionately kissing. This causes him a lot of jealousy and a kick in the face by a stray mule which, in the darkness, he mistakes for his wife's lover. Clever and well acted by Adele Lane and Edwin Wallock.

"The Adventure of the Lost Wife." (Edison. Mon., Nov. 16.)—Another of the adventures of Octavius, the amateur detective. He finds a wife who has had a little quarrel with her husband and gone away for a day to worry him. He is knocked down and left to paddle a boat home with a plank for an oar as a reward for his pains.

"The Everlasting Triangle." (Edison. Sat., Nov. 14.)—A made-in-New Jersey Western picture, which therefore lacks realism in scenery. The story is just what the name implies. The woman is left to go home, one man dies in the desert and the other commits suicide. Mabel Trunnelle and Frank McGlynn do some good acting.

"A Millinery Mix-Up." (Edison. Wed., Nov. 18.)—A woman enters her husband's office just as he is handing his stenographer her hat. She thinks he has just bought it for her, and as he has declined to let the wife buy one she becomes furious. The tightwad husband has but two hats, and loses his stenographer. On the same reel with "Buster Brown and the German Band."

"Buster Brown and the German Band." (Edison. Wed., Nov. 18.)—Buster's mother devotes herself to a bridge game and ignores him. He hires a German band to play under the window and the party is broken up.

"Dickson's Diamonds." (Edison. Sat., No. 21.)—A strong detective story concerning a diamond merchant who steals his own jewels to avoid payments to his creditors. There are some good light effects in scenes showing the crook's attempt to burn his barn by means of a tallow candle left in a barrel of hay. An ingenious way of opening a safe while far from the scene is also shown. Robert Conness heads the cast.

"The Locked Door." (Vitagraph. Three reels. Shown at Vitagraph Theatre.)—This picture made in collaboration with the New York City fire department shows clearly the advantage that the modern factory has over the old. A romance is interwoven with the lesson, making the picture a very desirable offering. Teft Johnson directed the picture and plays one of the principal parts. The rest of the cast, none of which are especially well known, are well suited to their roles.

"The Tangle." (Vitagraph. Four reels. Shown at Vitagraph Theatre.)—This is a military drama produced by Captain Harry Lambert, and featuring Naomi Childers and Darwin Karr. Although the acting of the cast is good, the inconsistency of the story rather lowers the picture's standard. The war which the picture has reference to, is our set-to with Spain, yet the time covered in the production is apparently the present. The plot is certainly a tangle, and is very entertaining, showing the troubles that a girl's foolish jealousy brought a great many people. Realism is added to the picture by the introduction of United States troops in the battle scenes.

UNIVERSAL PROGRAM

"Lizzie's Escape." (L. K. O. Sun., Nov. 15.)—Two mashers both try their hands at striking up an acquaintance with a country girl. They meet with varying success, and then try to take her money, but are frustrated. A fair slapstick.

"The Chorus Girl's Thanksgiving." (Kex. Two Reels. Sun., Nov. 15.)—Absorbing tale of the man in dire straits who robs to save his mother from death. A chorus girl shields him from the police, but he gives himself up so she may claim the reward; they are reunited later. Herbert Rawlinson and Anna Little are the principals.

"The Frankfurter Salesman's Dream." (Joker. Wed., Nov. 11.)—This is sure to produce laughter. Something new is introduced when we see Ernest Shields intruding

dogs up into "dogs." In his dreams his dogs attain great size and chase him. Trick photography adds to the amusement furnished.

"De Feet of Father." (Joker. Sat., Nov. 14.)—In most of the scenes of this picture only the feet of the principals are visible, but they are expressive enough to convey the correct idea. This is novel, but the same idea has been used by other companies.

"The Silent Peril." (101 Bison. Two Reels. Sat., Nov. 14.)—A number of fine thrills have been added to the story of the spy sent to discover and destroy an invention of a foreign power. Marie Walcamp, William Clifford and Sherman Bainbridge appear in their customary roles. The invention is a boat propelled by an electrical device on shore, and the spy destroys it by a contrivance of his own. An absorbing story full of rapid action. A realistic explosion of the boat occurs.

"Sissy Dobbins, Oil Magnate." (Powers. Fri., Nov. 13.)—Fair entertainment gathered from this drama. When the farmer's daughter becomes rich through the discovery of oil on the land, her suitor is afraid that he will be discarded, but she soon gets the idea out of his head. Edna Maison and Joe King play opposite.

"When the Girls Were Shanghaied." (Nestor. Fri., Nov. 13.)—A number of young husbands whose wives dress as men and go slumming disguise themselves as sailors and proceed to shanghai them. Much fun is furnished on board the ship, in fact, all the way through the picture. Ed Lyons, Lee Moran, Victoria Forde and Bess Meredith impersonate the main characters.

"The Star Gazer." (Nestor. Tues., Nov. 3.)—Murdock MacQuarrie always makes a picture, but this one boasts of novelty besides. A house is set afire by the sun's rays concentrated through a telescope fastened to the back of a chair. A heart interest story is presented; rather weak except for MacQuarrie's part, yet human.

"Peg o' the Wilds." (Imp. Two Reels. Thurs., Nov. 12.)—An interesting story of a wild mountain girl being found and tamed by a detective. Her father was an escaped criminal, living apart from the rest of the world with his daughter, but he dies before arrested. Violet Mercereau and William Shay are the principals. Hobart Henley is also in the cast.

"His Big Chance." (Victor. Mon., Nov. 2.)—A foreign princess poses as a maid. She sees her mistress in the arms of a strange man and is granted any favor. She chooses to be introduced to society as an heiress. She is proposed to, but when it is learned that she is a maid the man breaks the engagement. Then it is announced she is a princess, and the man begs forgiveness, but she had given him his chance and she does not forgive him.

"The Girl From Texas." (Frontier. Sat., Nov. 7.)—How the girl saves the man she loves from bandits makes an entertaining story. Something novel is introduced when the girl imitates the whirring of a rattlesnake. Fred Church and Edythe Sterling are the lovers.

"Race for a Bride." (Sterling. Thurs., Oct. 29.)—Good comedy of the two suitors for the girl. The one who brings the justice of the peace to the house first is to win her. The race is the most comical feature.

"The Wall Between." (Sterling. Mon., Nov. 2.)—An aged man lives on one side of the wall and a woman on the other. They quarrel, but their grandchildren are happy together and they are reconciled. Quite a pleasant comedy that will please.

"They Didn't Know." (Crystal. Tues., Nov. 2.)—An old idea and poor producing will cause this comedy to appear rather lifeless. An Irishman and a Dutchman are attracted by an actress. She strings them along for a time and then her husband appears.

"Her Own Home." (Eclair. Sun., Nov. 15.)—A pretty comedy drama played by Lottie Fowler, Fred Hearne and Fred Sumner. The girl is forced to sell her home. She returns disguised as an old housekeeper. The new owner learns her identity, and they marry.

"The Girl of the People." (Victor. Two Reels. Fri., Nov. 13.)—The plot seems weak

and poorly constructed, and no great amount of interest will be evidenced. Mary Fuller in the role of a mistreated Italian girl runs away from her father. She joins a gypsy band, but the leader takes too many liberties, and she leaves. In the city she becomes a great dancer and marries an artist after the black-mailing gypsy has been compelled to cease annoying the girl with his attentions.

"The Jungle Master." (101 Bison. Two Reels. Sat., Nov. 7.)—Although really a drama, the introduction of numerous species of wild animals overshadows the plot until the end of the last reel. Much excitement is caused by the fearless manner in which the principals handle the wild beasts. A very novel and entertaining number played by Henry McRae's old Bison company.

"The Crucial Moment." (Eclair. Sun., Nov. 1.)—A strong but somewhat concealed story is presented here, and at the crucial moment when the doctor is about to perform a serious experiment on a man, who is sacrificing his blood for money, the scene is set back, and the camera man is seen with the director close by taking the picture. "This is how the pictures are made," comes the announcement. A good picture and the "moment" is totally unexpected.

"The Vagabond." (Rex. Two reels. Sun., Nov. 1.)—Unconventionality marks this number, which is at the same time exceptionally entertaining. The worthless son of the family, played by Herbert Rawlinson, meets his double, a character played by the same man. The son dies and his double returns to his home, plays the impostor to comfort the dying mother, then makes himself known, and later marries the daughter of the family (Beatrice Van). William Worthington plays the father.

MUTUAL PROGRAM

"The Desperado." Broncho. Two reels. Wed., Nov. 4.)—A picture showing an old mother's devotion for her son even though he is the worst kind of a desperado. The story is put together in an excellent manner, and acted splendidly, so that suspense and interest are always kept at the highest. This review and the three following appeared by mistake in the Universal column last week. They are here reprinted in their proper place.

"Stout Heart But Weak Knees." (Keystone. Sat., Oct. 24.)—Charles Murray and the uproarious Keystone police are the chief fun makers in this reel. They are fun makers in every sense of the word and the picture will keep one in continual laughter.

"Shot in the Excitement." (Keystone. Mon., Oct. 26.)—We don't know just exactly where the "excitement" is, but from the picture it could be taken that it is any part of the human anatomy. Shooting, falling and throwing consume the greater part of the picture, and will create all manner of laughter, especially when a ridiculously slow cannon ball is seen pursuing a runaway couple.

"Left in the Train." (Thanouser. Sun., Oct. 18.)—The reconciliation of the girl and her father comes when the former's child is left in the train and is brought to the father by his two grand nieces. A very pretty story in which the Thanouser twins and the kiddlet play important parts.

"Dad and the Girls." (Beauty. Tues., Oct. 20.)—A man opposes his son's engagement to a stenographer, although he has never met her. On the advice of her lover she gets a place in his father's office. There she soon involves him in trouble which he is glad to escape from by consenting to the marriage. It is a good comedy.

"The Availing Prayer." (Reliance. Fri., Oct. 30.)—The underpaid, hard-working man is tempted to steal to aid his daughter. He extracts money from the sum he is carrying to the bank, but is attacked by thugs. Due to the money not being in the bag he saves it, and is rewarded. This makes an unusual story, played well by Spootiswoode Aitken and Dorothy Gish.

"The Ruin of Manley." (American. Two Reels. Mon., Nov. 2.)—This is an unconventional picture built around the ruins of the Los Angeles pigeon farm, when that place was destroyed by a flood recently. The story is good, and the realism that is instilled by the flood scenes is excellent. Winnifred Greenwood and Ed Coxen appear in the leading roles.

"A Mother's Influence." (Majestic. Tues., Oct. 27.)—Rather an old story but none the less entertaining, acted by Billie West and Wallace Reid in a convincing manner. The son marries a stenographer, and is disowned by his father. The memories of his wife reconcile the man to his son.

"A Flight for a Fortune." (Majestic. Two Reels. Sun., Oct. 25.)—A story of two unscrupulous lawyers who attempt to swindle a girl. They are frustrated by a clerk, employed in their office. A flying machine is introduced with thrilling results. A little less padding and the picture would be excellent. Signe Auen is the girl.

"Our Mutual Girl, No. 41." (Reliance. Mon., Oct. 26.)—Ralph Hamilton teaches Margaret the game of golf in this number. She meets Alec Smith, the former golf champion. She also views New York from Brooklyn Bridge, and again visits Mrs. Simcox's fashion establishment.

"A Madonna of the Poor." (Thanouser. Two Reels. Tues., Oct. 27.)—Muriel Ostriche in the leading role. Her husband, an Italian laborer, is out of work. She poses for an artist who takes liberties with her, which she resents. In order to gain money her husband upbraids her for these actions, but the sight of his little child restores him to his senses. The story will entertain but seems unfinished.

"The Hateful God." (Kay-Bee. Two Reels. Fri., Nov. 13.)—A picture showing the incidents that changed the religious ideas of a fanatic. He learns in the end that God is love. A fair story is woven in, but the idea seems a little too crudely put.

"Cursed by His Beauty." (Keystone. Sat., Oct. 31.)—Charles Murray appears as an iceman and boasts of a divine figure, which a feminine artist admires much to the annoyance of her husband and the iceman's wife. The jealous attitude of these two leads to a chase and a humorous scene which takes place in a unique bedroom.

"Shorty Falls into a Title." (Broncho. Two Reels. Wed., Nov. 18.)—In London, where the circus plays, Shorty is fired. An English lord is in dire straits because of the rabid suffragettes. Shorty impersonates him, and the situations that follow are very funny. Shorty finally returns to the circus.

"In the Clutches of the Gangsters." (Kay-Bee. Two Reels. Fri., Nov. 6.)—An exciting crook melodrama in which one of the gang reforms and after ridding himself of his past companions, marries. Numerous fights are staged of the most realistic variety.

"Bill Joins the W. W. W.'s." (Komic. Sun., Oct. 25.)—The ninth of the series featuring Tammany Bill Young and Fay Tincher. It tells of Bill joining the We Won't Work Society, and the trouble which it caused his employer. Among other things the safe had to be blown to get money to bail him out. Not quite up to the standard set by others of the series.

"A Blotted Page." (Reliance. Two Reels. Sat., Oct. 24.)—A wife divorces her husband because he has lost his money. The one servant left in the house tells him her story. She was once happy, but lost her husband and child through the failure of the banking house run by the father of the man to whom she is talking. Finding that they have faced the same sorrows, they are drawn together and decide to start life anew. The story is told in a succession of fade-away effects. Franselia Billington is featured.

"The Tightwad." (Beauty. Tues., Nov. 3.)—A tightwad farmer hoards his money in the fireplace and scorns all modern improvements, making drudges of his wife and daughter. A telephone secretly installed in a tree on the premises by his daughter's forbidden suitor, saves the farmer from a robbery by two tramps and brings the doctor in time of need. The tightwad is completely converted and fixes the house up with all the modern electrical appliances.

"The Ruin of Manley." (American. Two Reels. Mon., Nov. 2.)—The hitherto worthless Manley is on the point of making good and winning the girl he loves, through the pursuit of his pet hobby, pigeon raising, when a misunderstanding results in a quarrel between him and his sweetheart. This is followed by another catastrophe. His large pigeon farm, built upon what his rival knew to be dangerous ground when he sold it to him, is wrecked by a flood of the riv...

lowing a spring deluge. His sweetheart finds out her mistake and rushes back to Manley in his time of need. This picture features a large pigeon farm and contains very realistic flood scenes, excellent photography, unusual and interesting scenes, with a good plot well acted by Ed Coxen and Winifred Greenwood as principals.

"When the Road Parts." (American, Wed., Nov. 4.)—An interesting and cleverly produced drama, dealing with the redemption of a girl crook, who afterwards marries the man that she and her pal had planned to rob. A good plot, well acted by a cast including Winifred Greenwood, George Field and Ed Coxen.

"The Final Impulse." (American, Fri., Oct. 23.)—A man who has sinned greatly in the past gives up his life for that of a little girl. There is a strong cast, including Winifred Greenwood and Ed. Coxen, who are up to standard.

WARNER'S FEATURES

"The Mad Lovers." (Klarke's Komédies.)—Produced by Jack Clark and played by the Gaudier players. Two grotesque looking men have the name of cowards. For some hidden reason they get to fighting, and cut a few funny figures, which will call for a little laughter.

"Her Bandit Sweetheart." (Warners.)—The girl discovers her sweetheart is a bandit. She takes his loot to the sheriff and is awarded the prize for its return. She and the bandit live happily ever afterward. Good photography.

"Rescued by a Ranch Girl." (Warners.)—The cause of the action is rather vague. Two lovers elope and are pursued by the followers of a jealous suitor of the girl's hand. After a number of exciting events the pair arrive safely in the next town.

"The Bandit of Devil's Gap." (Premier, Sat., Nov. 21.)—How a western dancer saved the country doctor from being accused of a crime he did not commit is the basis of this picture. Joe Franz, Fred Church and Lillian Christy are in the cast. The story will entertain.

"Reuben's Busy Day." (Albuquerque, Thurs., Nov. 12.)—The adventures of an eloping couple are funny as portrayed here, especially when the young man hitches a wagon to his Stutz and pulls the rube around at a mile-a-minute clip, but the latter gentleman finally wins the girl. This is a fine comedy number, which will cause a great deal of amusement.

"Noisy Neighbors." (Starlight, Tues., Nov. 17.)—The chase is the main feature of this slapstick comedy, which results when two neighbors, both claiming that the other makes more noise than himself, in getting into a scrap. The drum rolling over hill and dale is a comical feature.

"A Taste of High Life." (Superba, Sun., Nov. 15.)—Charlie De Forrest again in a rather low but funny part. He is mistaken for an heir, and comes into a lot of money, which he spends without restraint. The mistake is discovered in the end and Charlie goes back to digging ditches. The girl in the picture rendered a performance pleasing in every feature.

"The Sage Brush Leading Lady." (Albuquerque, Thurs., Nov. 19.)—In which Dot Farley discovers that being the leading lady for a road show in her own home town isn't such a desirable position after all. Quite a few humorous moments in this.

"And the Villain Still Pursued Her." (Starlight, Tues., Nov. 10.)—All the action in this farce is inverted for a time, creating a most humorous effect. Not much real plot, although an elopement figures prominently in the comedy.

"The Gypsy's Warning." (Premier, Sat., Nov. 14.)—This is a strong story presented in a telling manner, sure to be appreciated. A gypsy is betrayed by a white man, and years later when she sees that a young girl is running into the same trap she warns her. Her warning is heeded, and all ends well as the man finally marries the old gypsy.

ECLECTIC-PATHE

"A World Without Men." (Eclectic, Three Reels.)—One of the newest releases of the Eclectic company. It tells of the adventures of three sisters who decided that men were in every way a delusion and a snare, and that they would never have anything to do with them. Accordingly, they obtained various positions, but their principles made it very hard for them to hold jobs, because they were all good looking and therefore received many attentions from the opposite sex.

A number of surprising episodes take place, but try as they will the sisters find that they are weakening in their attitude towards men. This is due to the fact that they have each encountered one man whom they regard as the great exception and different from all other men. They finally become engaged on the same day.

"The Poor Little Rich Boy." (Eclectic, Sat., Oct. 17.)—A little rich boy takes a little girl to a picnic in his pony cart, but he does not have nearly as much fun as the others. No one asks him to play baseball. When he tells his father he soon has a baseball suit and is very happy.

"Whiffles Has a Toothache." (Pathé, Sat., Oct. 17.)—A rather good comedy based on the trials of a toothache which would not down. It results in rather unexpected complications, but Whiffles forgives a man who punches his jaw because it ends the toothache.

"Mother's Darling Little Boy." (Pathé, One reel.)—Some good "rough house" acting and a number of funny situations make this picture one of much merit. A small boy who is believed by his parents to be what is implied in the title shows himself to be otherwise. A gang of hoboes and their remarkable meeting place add to the interest.

"Max in a Difficult Position." (Pathé, Split reel.)—On the same reel with "Whiffles' Nightmare." A very short but very funny comedy of a man who sustains a fracture in the seat of his dress trousers while on the way to a dance. There is a wealth of original humor in the picture.

"Whiffles' Nightmare." (Pathé, Split reel.)—An unusually good piece of trick photography. Not only does the same actor play two parts, but many other special effects are introduced. The story tells of a miser who refused to loan his habitually hard up brother any money. The brother pretends to have committed suicide and then "haunts" his victim. A good comedy made more interesting by the photography.

"A Soldier's Duty." (Eclectic.) Three reels.—This picture is a fine example of foreign skill in photography and settings. It tells a story of a soldier acting as a spy, who had the strength to give up his sweetheart for the sake of his country. It is an intensely and beautiful light effects. In one instance a man blows out a lamp in a window. The resulting puff of smoke is shown in the moon-dramatic picture, which abounds in fine scenes light. This is merely one example of what the camera man has accomplished.

NEWS WEEKLIES

"Mutual Weekly, No. 94." (Thurs., Oct. 15.)—Aside from the war news there is a number of other entertaining events pictured in this number. Baseball fans will have a chance to see the conquerors and the conquered of the world's series. The ruins wrought by two large fires are shown, one in Boston and the other in Houston, Texas. Other items combine to make this a very interesting number.

"Mutual Weekly, No. 96." (Thurs., Oct. 29.)—Scenes from Europe still hold a prominent place, various pictures of ruined towns and marching troops starting the reel. A view of the express train which was wrecked near Spracuse, N. Y., and the rescue of the wrecked Arctic steamer Karluk and her fearless crew are timely topics. Several domestic events complete the reel.

"Hearst-Selig News Pictorial, No. 69." (Selig, Mon., Oct. 26.)—The S. S. Metapan is shown after she foundered in New York Harbor, due to a collision with a freighter. The Navy-Pennsylvania football game at

Philadelphia is an interesting sporting event. War news, and a number of other minor happenings in the United States make this a very entertaining number.

"Animated Weekly, No. 137." There is a wide variety of pictures of news events in this issue, as well as a number of war views. The heroes of the world series baseball games are all shown. Among the war views are many interesting views of equipment and men as well as one picture of soldiers under fire.

"Animated Weekly, No. 138."—Nearly the whole reel is devoted to scenes from the war stricken countries. Views are shown of some of the best ships in the English navy and various activities in England connected with the fighting. Seven scenes in and around the battlefields of Belgium are of special interest. These give additional evidence of the manifold horrors of war.

INCORPORATIONS

At Albany, N. Y.: BELMONT THEATRE COMPANY, Newark; moving picture supplies; \$5,000; Adelbert Baier, South Orange; Frederick Conrad and Chas. Schaeztle, Newark.

LEWBERG OPERATING COMPANY, INC., Manhattan; motion picture business; capital, \$10,000. Incorporators: Samuel M. Berg, 162 W. 84th street; Henry Lewis, 130 W. 64th street; Henry Kaliski, 133 East 73d street, New York City.

BROWNSVILLE AMUSEMENT COMPANY, INC.; conduct motion picture establishment and amusement enterprises; \$3,000; Brooklyn; Davis and Albert Kerman and Lillian Berkowsky, of Brooklyn.

MARSCHNER BROS. & CO.; general contracting, including building of motion picture theatres; \$60,000; Rochester; Ernest E. and Wm. C. Marschner and Wm. H. McLean, of Rochester.

MULLER AMUSEMENT COMPANY, INC.; \$5,000; Brooklyn; Oscar, Minnie and Herbert Muller, of New York.

TAWAS COMPANY; theatrical and moving picture; \$1,000; New York. Irving and Myer Simon and Matilda Landsman, of New York.

FRISCO AMUSEMENT COMPANY; run and operate moving picture shows; \$4,500; Brooklyn. Marie Abrams, of Brooklyn; Mandel Heildraun and Louis Rubin.

MURRAY AMUSEMENT COMPANY, INC.; exhibiting moving pictures; \$25,000; Rochester. Wm. A. Buckley, Wm. McCormick, Jos. A. Kerbert, of Rochester.

COOKE-CRONER EXHIBITION COMPANY, INC.; motion picture business; \$10,000; Manhattan. Julian A. Leve, Jno. J. Laine, Jno. H. Sears, of New York.

THE EXHIBITORS' ALL-FEATURE FILM COMPANY; general motion pictures; \$18,000; Albany. Martha L. Garson, Edward Butcher, of Troy, and Edgar I. Garson, of Albany.

NEW YORK ALCO FILM SERVICE, Manhattan; \$25,000. H. B. Danizer, 316 West 93d street, N. Y.; U. S. Hill, Queens; Abraham Canter, New York.

At Dover, Del.: BRISTOL AMUSEMENT AND REALTY COMPANY, Providence, R. I. Capital stock, \$50,000. To deal in real estate, moving pictures and real estate amusement companies of all kinds. Incorporators: Charles A. Wright, O. Z. Peterson, James S. Newton, all of Providence, R. I.

At Richmond, Va.: TANHOUSER SYNDICATE CORPORATION of Richmond; \$1,000 to \$3,000,000; to conduct the motion picture business in all its branches. Ernest B. Flippen, Richmond; W. R. Johnston, New Rochelle, N. Y.

At St. Paul, Minn.: THE STRAND AMUSEMENT COMPANY, St. Paul; to own and operate motion picture theatres. Harold C. Kerr, Joseph Friedman, Charles Friedman and Theodore L. Hays, all of St. Paul.

At Springfield, Ill.: I. C. U. FILM COMPANY, Chicago; capital stock \$10,000; take, develop and deal in films for moving picture machines, etc. William P. MacCracken, Jr., Norman H. Prichard and Urban A. Lavery.

THE RICH FEATURE FILM EXCHANGE, "Richest Feature Films," Chicago; capital stock, \$2,500; manufacture and deal in motion picture films, etc. Albert B. Reiss, Clarence R. Rich; E. J. Rich.

THE T. R. FILM COMPANY of Chicago has been incorporated with a capital stock of \$35,000. It is to manufacture picture films and deal in the same. The incorporators are J. Frederick Reeve, M. M. Foshringer and James J. Trainor.

Uncle Sam Neutral On "Ordeal" Question

Goldburg Consults Acting Secretary of State Lansing Regarding the Alleged Partisan Character of Life Photo Production

JESSE J. GOLDBURG, secretary and executive manager of the Life Photo Film Corporation, returned recently from Washington where he consulted with Acting Secretary of State Robert Lansing and Third Assistant Secretary of State Phillips with respect to the Life Photo Film Corporation's latest five-part feature release "The Ordeal," adapted from a poem revolving about the great struggle of the Franco-Prussian War.

The negotiations with the Department of State were as a result of certain protests against the possible release of "The Ordeal" on the part of certain German societies which maintained that the production might possibly violate the proclamation of neutrality of President Wilson.

The contention of the Life Photo Film Corporation was that "The Ordeal" did not pretend to depict any true state of affairs, but was merely a poetic adaptation, and whatever realism was portrayed in the picture did not detract from the fact that the company never claimed the picture recited any true events possibly connected with the present unfortunate state of affairs in Europe.

The company's position is further taken that if any construction is to be placed upon the production, it is that "The Ordeal" is an argument for universal peace in so far as it depicts, although in fiction, the horrors of war.

Mr. Goldburg laid before the State Department these facts, together with certain endorsements from ministers who were present at the private showing of the production at the American

Theatre. Their approval was unqualified.

Assistant Secretary of State Phillips, after thoroughly going into the matter with Acting Secretary of State Lansing and Mr. Goldburg, finally determined that the Department of State would not prohibit the exhibition of "The Ordeal," and would not entertain any complaint against it.

Of course they could not endorse that or any other production, it being entirely without their province to issue certificates of approval.

ACTRESS NURSES INVALID SISTER

The home life of few actresses presents as sweet an aspect as does that of Cleo Madison, the clever leading woman with the Gold Seal company, at present engaged in the production of Louis Joseph Vance's "Trey o' Hearts" series.

Miss Madison lives with and is the sole support of her mother and her invalid sister Helen, known to all her host of friends as "Sunshine," because of her cheerful disposition. Helen is twenty years old and for the past seven years has been unable to walk.

The two girls are inseparable and when Miss Madison is not busy before the camera, she may always be found wheeling little "Sunshine" up and down the long shady avenues of Hollywood or sitting reading to her in some pleasant nook on the palm strewn lawn that surrounds the Madison home.



MENGER & RING

302 W. 42nd Street
New York

TELEPHONE

BRYANT 6621

FURNITURE & FURNISHINGS

On RENTAL

We equip your settings complete in accordance with your scenario.

WILLIAM BIRNS

103-105 West 37th St.

Phone: Greeley 6255.

SAVE 35%

on your

CARBONS

Burn your stubs
with a

**CARBON
Economizer**



Fits any lamp, gives perfect contact and conductivity, made of best material, screw does not come in contact with carbon, and will not weld to body of economizer; will burn upper or lower carbon to 3/4 of an inch. **NOW IN USE—784—NOW IN USE** "MECHANICALLY CORRECT"!!
Guaranteed to give satisfaction.

\$1.25 each. Sizes 1/2", 5/8", 3/4" \$2.00 Set—any sizes.
Sent postpaid upon receipt of New York Draft. Money Order or Cash.
THE CARBON ECONOMIZER CO.
757 W. Onondaga St. Syracuse, N. Y.

The Motion Picture News
\$2.00 Per Year
"The Fastest Growing Picture Journal"

"THE NIGHTINGALE" MEETS WITH INSTANT SUCCESS

The best evidence of the success of the Alco program from its very beginning is found in the fact that at the present time seven prints of Ethel Barrymore in "The Nightingale" are in use in New York State alone, and negotiations are under way for placing the release in numerous other theatres.

The drama, which Augustus Thomas wrote for Miss Barrymore, has had a big run in Boston, Philadelphia, Pittsburgh and other cities. This tragedy of love and music was number one on the Alco program, and hence officials of the releasing corporation and of the All Star Feature Corporation are intensely gratified with these results.

The production was booked at Hammerstein's Lexington Opera House for the week commencing November 1. Negotiations are now pending between the Life Photo Film Corporation and one of the largest concerns supplying regular feature programs for the purchase of the rights to "The Ordeal" for the United States and the Dominion of Canada.

FIGHT BATTLE IN WATER

It was Herbert Brenon and Hobart Henley who, at great risk, dived into twenty feet of water, where they put up one of the most unique and spectacular fights ever done for the screen.

This forms one of the scenes for "In Self Defense," a two-reel drama produced by the Imp Company, under the direction of Herbert Brenon, up in the wilds of Connecticut.

Hobart Henley, as the brother, pursues Mr. Brenon, who enacts the role of the villain, to avenge an attempted wrong on his sister. The chase leads on to a lake where the two canoes clash together. Mr. Henley is dragged into the water, and, after a terrific struggle, finally succeeds in strangling his opponent.

The remainder of the story concerns the apprehension and trial of the brother and the love which the sister has for a detective.

Violet Mersereau is seen in the role of the sister. Billy Shay plays the detective, while William Welsh and Mrs. Walker are seen as the father and mother of the boy and girl.

**THE ALBUQUERQUE FILM
MFG. COMPANY, Inc.**

Featuring that clever
Comedienne

Miss Dot Farley

Two Comedies Weekly

RELEASING THROUGH
The United Motion Picture Producers, Inc.
WHO DISTRIBUTE THROUGH
Warner's Features, Inc.

By request from many exchanges
we take pleasure in
reviving the

**FRONTIER
TWIN STORIES**

Written and made famous by Miss Dot
Farley. Under direction of

Gilbert P. Hamilton

Farce Comedy Production

BY

ARCHER McMACKIN

Nuf Sed

WESTERN STUDIO

406 Court St. Los Angeles, Calif.

GILBERT P. HAMILTON, Pres. and Gen. Mgr.

"PLAYING WITH FIRE"

(Selig—Two Reels)

REVIEWED BY C. J. VERHALEN

A STARTLINGLY true photoplay that might be enacted any day in real life. The story is of "The Moth and the Flame" type, but rendered in a way that gives it a new interest. It portrays a character that is so genuine and so realistic that it makes the photoplay refreshing.

Bessie Eyton plays this part. She shows the great strength and the great weakness of woman. After playing with fire she sees her wrong. She determines to be true to her husband, and she is, but the forced attentions of the other man which she fears to confess to her husband makes a web of circumstantial evidence that blackens her in the sight of her husband.

And he, when the rival makes a written confession, does not believe it as he had been a scoundrel; neither will he believe her. It makes a very strong finish, just a bit different from the stereotyped kind where everything ends happy, and tends to give the picture a moral. Miss Eyton and Thomas Santschi play the leading parts.

Mary Ransom, a charming young wife, permits Horton, a friend of the family, to shower his attentions on her. Horton so compromises her that she is embarrassed and would be free from his friendship. John Ransom talks to his wife upon the subject. Horton writes Mary a letter, which is intercepted by John.

Horton forces his attention on her in a restaurant and is discovered by John. For the sake of their son, John tries to believe her when she explains. They go to their cabin in the woods. Horton invents a subterfuge for getting John back to the city. After John leaves the cabin Horton enters. He is later discovered by John. This is the final stroke—the last straw.

Husband and wife separate. Horton on his death bed confesses to Mary, who has become a nurse, John will not believe the confession and they continue in their separate spheres.

TITLES

Our *Title Department* has been re-organized, elaborately equipped and placed under the direction of recognized experts.

Its highly perfected apparatus, lino-type machine and job presses enable us to produce the most difficult title work in any language—artistically, accurately and *quickly*—and at *lower prices* than have ever yet been quoted.

**DEVELOPING
AND PRINTING**

Save money and insure the best results by entrusting your work to the *largest and most complete commercial plant in America.*

**CENTAUR
FILM CO.**

Bayonne, N. J., and 1600 Broadway, N. Y.

SPECIAL FEATURES

General Film Company

TITLE	MAKE	No. of Reels	TITLE	MAKE	No. of Reels
THIRD DEGREE	Lubin	5	OTHELLO	Kleine	5
THOR, LORD OF JUNGLE.....	Selig	3	SHANNON OF SIXTH.....	Kalem	5
THE BATTLE OF SHILOH.....	Lubin	4	MAN'S ENEMY	K. & E. Biograph	3
THE LION AND THE MOUSE.....	Lubin	6	IN TUNE WITH THE WILD.....	Selig	3
THROUGH FIRE TO FORTUNE.....	Lubin	5	THE WOLF	Lubin	6
JUDITH OF BETHULIA.....	Biograph	4	SHADOWS OF THE PAST.....	Vitagraph	3
GERMINAL	Pathe	5	MR. BINGLES' MELODRAMA.....	Vitagraph	3
LOST IN MID OCEAN.....	Vitagraph	3	MEN AND WOMEN.....	K. & E. Biograph	3
A ROMANY SPY.....	Pathe	3	THE SECRET OF RING.....	Kleine	3
A CELEBRATED CASE.....	Kalem	4	MY FRIEND FROM INDIA.....	Edison	3
THE FULFILLMENT	Essanay	3	LIBERTY BELLES	K. & E. Biograph	3
NIGHT RIDERS OF PETERSHAM.....	Vitagraph	3	THE ERRING	Lubin	3
HARDING'S HERITAGE	Pathe	3	AMBUSHED	Essanay	3
DAUGHTERS OF MEN.....	Lubin	5	SONG OF THE SOUL.....	Kleine	3
THE OTHER HALF OF THE NOTE.....	Kalem	3	KIT, THE ARKANSAS TRAVELER.....	Kalem	3
HER LADYSHIP	Selig	3	CHIP OF THE FLYING "U".....	Selig	3
GOODNESS GRACIOUS	Vitagraph	3	FAIR REBEL	K. & E. Biograph	3
OFFICER JIM	Lubin	3	HOUSE NEXT DOOR.....	Lubin	5
DEATH SIGN AT HIGH NOON.....	Kalem	3	MY OFFICIAL WIFE.....	Vitagraph	5
GAME OF LIFE.....	Selig	3	UNCLE BILL	Vitagraph	3
THE MILITANT SUFFRAGETTE.....	Pathe	5	THE FORTUNE HUNTER.....	Lubin	6
FRANCIS MARION, "THE SWAMP FOX".....	Kalem	3	THE VENDETTA.....	Kleine	5
A MILLION BID.....	Vitagraph	5	BAREFOOT BOY	Kalem	3
THE FATAL WEDDING.....	K. & E. Biograph	3	THE WIFE	K. & E. Biograph	3
THE GAMBLERS	Lubin	5	KING OF CHANCE.....	Kalem	3
ANNE BOLEYN	Kleine	3	THE WAGES OF SIN.....	K. & E. Biograph	3
STRUGGLE FOR LIFE.....	Pathe	5	THE PLUM TREE.....	Essanay	3
MONGREL AND MASTER.....	Essanay	3	THE FIFTH MAN.....	Selig	3
THE ROYAL BOX.....	Selig	4	THE GOLDEN BEETLE.....	Kleine	4
THE CURSE OF CREED.....	Melies	5	THE WEIGHT OF A CROWN.....	Lubin	3
FACING THE FOOTLIGHTS.....	Pathe	3	MARAH, THE PYTHONESS.....	Lubin	3
BLOOD WILL TELL.....	Essanay	3	CHARITY BALL	K. & E. Biograph	3
CONQUEST OF QUEBEC.....	Kalem	5	HEARTS AND MASKS.....	Selig	3
THE LILY OF THE VALLEY.....	Selig	3	A FLORIDA ENCHANTMENT.....	Vitagraph	5
CLASSMATES	K. & E. Biograph	4	ROAD TO YESTERDAY.....	K. & E. Biograph	3
MAN OF THE HOUR.....	Selig	3	THE PAINTED WORLD.....	Vitagraph	3
MR. BARNES OF NEW YORK.....	Vitagraph	6	JUDGE NOT	Kleine	4
LOVE, LUCK AND GASOLINE.....	Vitagraph	3	GARRISON'S FINISH	Selig	4
THE BILLIONAIRE	K. & E. Biograph	3	POWER OF THE PRESS.....	K. & E. Biograph	3
SPORT AND TRAVEL IN AFRICA.....	Pathe	5	IN THE GLARE OF LIGHTS.....	Essanay	3
THE GOOD FOR NOTHING.....	Essanay	4	THE RED CROSS NURSE.....	Melies	3
THE BOER WAR.....	Kalem	5	THE THREADS OF DESTINY.....	Lubin	5
THE THUMB PRINT.....	Melies	4	WHEN THE LIONS ESCAPE.....	Melies	3
STRONGHEART	K. & E. Biograph	3	THE GENIUS	K. & E. Biograph	3
LORD CHUMLEY	K. & E. Biograph	4	STONEWALL JACKSON'S WAY.....	Lubin	3
SEVEN DAYS	K. & E. Biograph	3	THE INVISIBLE POWER	Kalem	4
TREASURE OF ABDAR RAHMAN.....	Pathe	4	THE WOMAN IN BLACK.....	K. & E. Biograph	4
'NEATH THE LION'S PAW.....	Melies	3	UNDER THE GASLIGHT.....	K. & E. Biograph	4
ONE WONDERFUL NIGHT.....	Essanay	4	"413"	Vitagraph	3
WOMAN AGAINST WOMAN.....	K. & E. Biograph	3	THE WIN(K)SOME WIDOW.....	Vitagraph	4
IN DEFIANCE OF LAW.....	Selig	3	THE STORY OF THE BLOOD RED ROSE.....	Selig	3
A KINGDOM AT STAKE.....	Kleine	3	THE TELL TALE HAND.....	Essanay	3
CAPTAIN ALVAREZ	Vitagraph	6	A POOR RELATION.....	K. & E. Biograph	3



Registered.

OUR NEXT RELEASE
**Mrs. THOMAS
 WHIFFEN**

The Grand Old Lady of the
 American Stage

Now scoring a Tremendous Success at the Lyceum Theatre, New York, in

"The Beautiful Adventure"

in a
 FIVE-PART PHOTOPLAY

"HEARTS
 and
 FLOWERS"

A Thrilling Drama of Love and Sacrifice

Adapted by and Produced under the Direction of

JOSEPH A. GOLDEN

STATE RIGHT BUYERS

who are looking for exceptional features will secure their territory AT ONCE.

DO NOT HESITATE
 THIS IS A SURE WINNER

COSMOS FEATURE
 FILM CORPORATION

126 West 46th St., New York

CINEMA DANCE A SUCCESS

The invitation, reception and dance given by the Cinema Camera Club of American in Pabst Coliseum, on Saturday evening, October 10, proved to be just as successful as was predicted. In January the club will give its annual ball to commemorate the second year of its existence. This affair commemorated nothing in particular, but will bring remembrances of a good time to all those who were fortunate enough to be present.

There were many screen stars in attendance, chief among them being Clara Kimball Young, James Kirkwood and Mary Pickford. The first two led the grand march. Members of the Vitagraph, Edison, Peerless, Universal and Famous Players' companies were also on hand.

The members of the reception committee who saw that everyone was well taken care of were: Otto Brautigam, Harry Bredson, Emmett Williams, William Forsyth, Lyman Broenig and Edward Wynard.

WURLITZERS PLACED IN SIX
 HOUSES

The Rudolph Wurlitzer Company, of Cincinnati, Ohio, has recently installed its motion picture orchestras in the following theatres: The Eagle Theatre, 1717 South Broadway, St. Louis, Mo.; the Aragon Theatre, 2108 Vine street, Cincinnati, Ohio, William Gorvers, manager; the Idle Hour Theatre, 7029 Main street, Carthage, Ohio, William Gerard, manager; the Ruston Opera House, Ruston, La., Louis Astor, manager; the Show House, New Orleans, La., Victor Perez, owner; the Pelham Theatre, Philadelphia, B. Haas, manager.

INQUEST CLUB FULL OF LIVE
 ONES

Special to MOTION PICTURE NEWS

Rochester, N. Y., Oct. 26.

Rochester has a branch of the Inquest Club. This is an organization of photo playwrights, which meets each Wednesday evening at the Victoria Theatre, for the purpose of studying and discussing the technique of the photoplay. Mrs. Nettie Armstrong is the head of the local branch. There are no dues or fees of any sort, and the only thing required to become a member is a sincere interest in the art of photoplay writing.

Lantern Slide Mat Co.

Manufacturers of

Lantern Slide Mats and
 Reel Bands

Prompt
 Service

Prices
 Right

Best
 Goods

149 W. 35th St., New York

Telephone: Greeley 6414

Our Factory Is Yours!

Negative assemblers, projecting machines and an equipment second to none, with an organization of experienced people always at your SERVICE for DEVELOPING and PRINTING.

EVANS FILM MFG. CO.

Incorporated

416-22 WEST 216th STREET
 Tel. 7652 Audubon at Broadway, New York

ARE YOU HAVING BOOKING TROUBLE?

Are you getting the films you want—or are paying for?

Save trouble, time and money by booking your films through the

Managers Booking Bureau

Suite 1012, Hartford Building, Chicago
 PHONE—CENTRAL 2448

Motion Picture Booking for the States of Illinois, Indiana and Michigan.

Films Reviewed.

Exhibitors' Supply Service.

Information regarding any branch of the Motion Picture business.

Write now for particulars.

Kinematograph Weekly

\$5.15 a Year

The Leading Motion Picture
 Publication of Great Britain and
 Colonies

Sample Copies 10 cents

For Advertising Rates Write

Associated Moving Picture Press
 250A Kingston Ave., Brooklyn, N. Y.

REBUILT MACHINES

We have on hand at all times a number of REBUILT MACHINES.
 All in first class order.

Powers' No. 5 Complete with Fire Shutter	\$75.00
Edison Exhibition, one pin movement	65.00
1911 Motiograph, complete	110.00
1912 Motiograph, complete	125.00
Powers' No. 6, complete	125.00
Powers' No. 6, with 1912 Motiograph Lamp House	135.00

A-1 condition guaranteed.

Will sell for CASH or on EASY PAYMENTS.

Write for new catalog just off the press.

AMUSEMENT SUPPLY COMPANY
 160 No. Fifth Ave., Chicago, Ill.

What Do You Need?

LISTING IN THE BUYERS' GUIDE, FOR NAME AND ADDRESS, INCLUDING ONE YEAR'S SUBSCRIPTION TO THE MOTION PICTURE NEWS—\$8.00 A YEAR, CASH IN ADVANCE. FREE TO ADVERTISERS USING \$100.00 OR MORE WORTH OF DISPLAY SPACE DURING THE YEAR. ADDRESS ADVERTISING DEPARTMENT

ADVERTISING NOVELTIES

Philip Hano, 806-810 Greenwich St., New York.

ANNOUNCEMENT SLIDES

Niagara Slide Co., Lockport, N. Y.

ASBESTOS BOOTHS

Sharlow Bros., 442 W. 42nd St., New York.

CLEANING AND RENOVATING FILM

Film Redeveloping Co. of America, 145 W. 45th St., N. Y.
Multicolor Film Improving Co., Inc., 15 E. 26th St., N. Y.

COSTUMERS

Miller-Costumier, 236 South 11th St., Philadelphia, Pa.

DEVELOPING TANKS

A. J. Corcoran, Inc., 9½ John St., New York.

ELECTRIC LIGHTING SETS

The Chas. A. Strelinger Co., Box P-2, Detroit, Mich.

FILMS

(Manufacturers, Dealers and Renters)
American Film Mfg. Co., Chicago, Ill.
Thomas A. Edison, Inc., 275 Lakeside Ave., Orange, N. J.
Essanay Film Mfg. Co., First National Bank Bldg., Chicago, Ill.
General Film Co., 200 Fifth Ave., New York.
George Kleine, 166 N. State St., Chicago, Ill.
Lubin Mfg. Co., Philadelphia, Pa.
G. Melies, 204 E. 38th St., New York.
Mutual Film Corp., 71 W. 23rd St., New York.
New York Motion Picture Corp., Longacre Bldg., New York.
Pathé Freres, 1 Congress St., Jersey City, N. J.
Renfax Film Co., Inc., 110 W. 40th St., N. Y.
Selig Polyscope Co., Chicago, Ill.
Thanhouser Film Corp., New Rochelle, N. Y.
Universal Film Mfg. Co., 1600 Broadway, N. Y.

FILM ACCESSORIES

Berlin Aniline Works, 213 Water St., N. Y.

FILM TITLES, PRINTING, DEVELOPING, ETC.

Commercial Motion Pictures Co., Inc., 220 W. 42nd St., New York.
Centaur Film Co., 670-682 Ave. E, Bayonne, N. J.
Evans Film Mfg. Co., 412-22 W. 216th St., at Broadway, New York.
Gunby Bros., Inc., 145 W. 45th St., New York.
Industrial Moving Picture Co., 223-233 W. Erie St., Chicago.
Standard Motion Picture Co., 5 S. Wabash Ave., Chicago.
Standard Filmprint Corp., 120 School St., Yonkers, N. Y.

FILM REELS

Lang Mfg. Works, Olean, N. Y.
Taylor-Shantz Company, 224 Mill St., Rochester, N. Y.

FURNITURE AND FURNISHING ON RENTAL

William Birns, 103-105 West 37th St., N. Y.

FEATURE FILMS

Alco Film Corp., 218 W. 42d St., New York.
Alliance Films Corp., 126 W. 46th St., New York.
Albuquerque Film Mfg. Co., Inc., 406 Court St., Los Angeles, Calif.
All Star Feature Corp., 220 W. 42nd St., N. Y.
Amrosio American Co., 15 E. 26th St., N. Y.
Bosworth, Inc., 640 N. Olive St., Los Angeles, Cal.
Box Office Attraction Film Rental Co., 130 W. 46th St., New York.
A. Blinkhorn, 110 W. 40th St., New York.
California Motion Picture Corp., San Francisco, Cal.

Cosmofotofilm Co., 110 W. 40th St., New York.
Cosmos Feature Film Corp., 126-130 W. 46th St., N. Y. City.

Direct-From-Broadway Features Co., 46 W. 24th St., New York.

Eclair Film Co., 126 W. 46th St., New York.
Eclectic Film Co., 110 W. 40th St., New York.
Excelsior Feature Film Corp., Inc., 110 W. 40th St., N. Y.

G. W. Feature Film Corp., 145 W. 45th St., N. Y.

Features Ideal, 126 W. 46th St., New York.
Famous Players Film Co., 213-229 W. 26th St., New York.

Films Lloyds, Inc., 220 W. 42nd St., N. Y.
General Film Co., 200 Fifth Ave., New York.
General Feature Film Co., 313 Mallers Bldg., Chicago, Ill.

Gaumont Co., 110 W. 40th St., New York.
Greene's Feature Photo Plays, Inc., 110 W. 40th St., New York.

W. W. Hodkinson, 110 W. 40th St., New York.
Imperial Motion Picture Co. of N. Y., Inc., 1476 Broadway, N. Y.

Inter-Continent Film Co., 110 W. 40th St., New York.

George Kleine Attractions, 166 N. State St., Chicago, Ill.

New York Office: 1476 Broadway.
Jesse L. Lasky Feature Play Co., Longacre Theatre, New York.

Life Photo Film Corp., 220 W. 42nd St., N. Y.
Mecca Feature Film Co., Inc., 126 W. 46th St., New York.

Mohawk Film Co., Times Bldg., New York.
Oz Film Mfg. Co., Santa Monica Blvd., Los Angeles, Cal.

Paramount Pictures Corp., 110 W. 40th St., New York.

Phoenix Feature Film Corp., 129-131 Columbus Ave., Boston, Mass.
Photo Play Production Co., 220 W. 42nd St., New York.

Picture Playhouse Film Co., 110 W. 40th St., New York.

Playgoers Film Co., Lyric Theatre, New York.
Popular Plays and Players Co., 1600 Broadway, New York.

Progress Film Co., 110 W. 40th St., New York.
Progressive Motion Picture Corp., Times Bldg., New York.

Ramo Films, Inc., Columbia Theatre Bldg., New York.
Rolands Feature Film Co., 145 W. 45th St., New York.

A. H. Sawyer, Inc., 1600 Broadway, New York.
Select Photo Play Producing Co., Inc., 71 W. 23rd St., New York.

Sterling Camera & Film Co., 145 W. 45th St., New York.

Solax Co., Fort Lee, N. J.
The Masterpiece Film Mfg. Co., 1111 Van Nuys Bldg., Los Angeles, Cal.

The Photoplay Productions Releasing Co., 37 S. Wabash Ave., Chicago, Ill.
Union Features, 126 W. 46th St., New York.

Universal Film Mfg. Co., 1600 Broadway, N. Y.
University Films, Inc., 110 W. 40th St., N. Y.

Edw. H. Wagner, Agt., Dania Biofilm Co., 38 Park Place, N. Y.
World Film Corporation, 130 W. 46th St., New York.

Warner's Features, Inc., 130 W. 46th St., N. Y.

LANTERN SLIDE MATS AND REEL BANDS
Lantern Slide Mat Co., 149 W. 35th St., N. Y.

LABELS

Every Ready Roll Label Co., 203-7 W. 40th St., New York City.

LIGHTING PLANTS

Cushman Motor Works, Lincoln, Neb.

LOBBY PHOTOS

The Wyanoak Pub. Co., 136 W. 52nd St., N. Y.

MOTION PICTURE MACHINES AND SUPPLIES

Amusement Supply Co., 160 E. North Fifth Ave., Chicago, Ill.

Behrend Motion Picture Supply House, 440 Fourth Ave., New York.

Calehuff Supply Co., 1301 Race St., Philadelphia, Pa.

Enterprise Optical Co., 568 W. Randolph St., Chicago, Ill.

Lears Theatre Supply Co., Sam Lears, Prop., 509 Chestnut St., St. Louis, Mo.

Oliver Moving Picture Supply Co., 647 Euclid Ave., Cleveland, O.

Picture Theatre Equipment Co., 21 E. 14th St., New York.

Precision Machine Co., 317 E. 34th St., N. Y.

Nicholas Power Co., 90 Gold St., New York.

The Phantoscope Mfg. Co., Washington, D. C.

Sweeley's Photo Supply House, 514-516 Erie Ave., Renova, Pa.

Williams, Brown & Earle, Inc., 916-918 Chestnut St., Philadelphia, Pa.

MOTION PICTURE APPARATUS

Burke & James, Inc., 240-258 E. Ontario St., Chicago, Ill.

MUSICAL INSTRUMENTS

American Photo Player Co., 62 W. 45th St., New York City.

Rudolph Wurlitzer Co., Cincinnati, O.

OPERA CHAIRS

The Hardesty Mfg. Co., Canal Dover, Ohio.
Steel Furniture Co., Grand Rapids, Mich.

POSTER AND PICTURE FRAMES

Menger & Ring, 442 W. 42nd St., New York.

PIPE ORGANS

Henry Pilcher's Sons, 914-920 Mason Ave., Louisville, Ky.

M. P. Moller, Hagerstown, Md.

PROJECTION LENSES

Bausch & Lomb Optical Co., 569 St. Paul St., Rochester, N. Y.

POSTERS

The Morgan Lithograph Co., Cleveland, Ohio.

RAW FILM

Eastman Kodak Co., Rochester, N. Y.
Celluloses Planchon, Inc., 75 Fifth Ave., New York.

David Horsley, 1600 Broadway, N. Y.
Raw Film Supply Co., 15 E. 26th St., N. Y.

REWINDERS AND GENERAL SUPPLIES

L. C. Smith Co., Schenectady, N. Y.

SCREENS

Atsco, Inc., 218 West 42nd St., New York.
Day & Night Screens, Inc., 110 W. 40th St., New York.

Mirror Screen Co., Inc., Shelbyville, Ind.

STEEL FILM EQUIPMENT FOR EXCHANGES AND MFRS.

Columbia Metal Box Co., 226-228 E. 144th St., New York.

TICKETS—ROLL AND COUPON

Rees Ticket Co., 400 S. 10th St., Omaha, Neb.

THEATRE LOBBY FRAMES AND FIXTURES

Newman Mfg. Co., 715 Sycamore St., Cincinnati, O.

UNIFORMS

Fechheimer Bros., Union-made Uniforms, Cincinnati, O.

VENTILATION, COOLING AND HEATING

Typhoon Fan Co., 1544 Broadway, N. Y.

Record of Current and Coming Releases

GENERAL FILM PROGRAM

RELEASES OF THE WEEK

Monday, October 26, 1914.

BIOGRAPH—The Squashville School, C., 540.....	16280
The Villainous Uncle, C., 460.....	
EDISON—Wood B. Wedd and the Microbes, C., 1000	16286
ESSANAY—Rivalry and War, C., 1000.....	16288
KALEM—The Lynbrook Tragedy, D., 2000.....	16281
LUBIN—The Holdup, the Beloved Adventurer Series, D., 1000.....	16289
SELIG—Playing with Fire, D., 2000.....	16284
SELIG—Hearst-Selig News Pictorial No. 69, N., 1000	16287
VITAGRAPH—The Cave Dwellers, C., 1000	16285

Tuesday, October 27, 1914.

BIOGRAPH—The Ticket-of-Leave Man, D., 2027..	16299
EDISON—The Mystery of the Sealed Art Gallery, D., 1000	16290
ESSANAY—An Unplanned Elopement, D. 1000...	16291
COLUMBUS—Mulligan's Ghost, C., 1000.....	16296
KALEM—The No-Account Count, C., 1000.....	16297
LUBIN—Love and Title, C., 400.....	16295
She Married for Love, C., 600.....	
SELIG—Why the Sheriff Is a Bachelor, D., 1000...	16292
VITAGRAPH—The Butterfly, C., 2000.....	16293

Wednesday, October 28, 1914.

EDISON—The Lost Melody, D., 1000.....	16300
ESSANAY—The Fable of "The People's Choice Who Answered the Call of Duty and Took Seltzer," C., 1000.....	16303
KALEM—The Menace of Fate, D., 2000.....	16301
LUBIN—The Mountain Law, D., 2000.....	16306
SELIG—The Wasp, D., 1000.....	16305
VITAGRAPH—William Henry Jones' Courtship, C., 1000	16304

Thursday, October 29, 1914.

BIOGRAPH—The Wife's Stratagem, D., 999.....	16308
ESSANAY—Snakeville and the Corset Demonstrator, C., 1000.....	16309
LUBIN—The Wolf's Daughter, D., 2000.....	16310
SELIG—Hearst-Selig News Pictorial No. 70, N., 1000	16307
VITAGRAPH—Kidding the Boss, C., 1000.....	16312

Friday, October 30, 1914.

BIOGRAPH—The Tides of Sorrow, D., 997.....	16322
EDISON—The Midnight Ride of Paul Revere, D., 2000	16314
ESSANAY—Whatever a Woman Soweth, D., 2000	16316
KALEM—Ham and the Villain Factory, C., 1000...	16318
LUBIN—Thumb Prints and Diamonds, D., 1000...	16321
SELIG—The Grate Impeeryul Sirkus, C., 1000.....	16319
VITAGRAPH—Bunny Backslides, C., 1000.....	16320

Saturday, October 31, 1914.

BIOGRAPH—Hearts of Gold, D., 999.....	16329
EDISON—The Hand of Iron, D., 1000.....	16323
ESSANAY—Broncho Billy's Mother, D., 1000.....	16324
KALEM—The Vengeance of Winona, D., 1000.....	16328
LUBIN—The Soubrette and the Simp, C., 400.....	16325
An Interrupted Nap, C., 600.....	
SELIG—At the Transfer Corner, C., 1000.....	16330
VITAGRAPH—Within an Ace, D., 2000.....	16326

RELEASES OF NEXT WEEK

Monday, November 2, 1914.

BIOGRAPH—All for Business, D., 997.....	16331
EDISON—The New Partner, D., 1000.....	16337
ESSANAY—The Laundress, C., 1000.....	16338
KALEM—His Inspiration, D., 2000.....	16333
LUBIN—A Partner to Providence, Beloved Adventurer Series No., D., 1000.....	16340
SELIG—Rosemary, That's for Remembrance, D., 2000	16334
SELIG—Hearst-Selig News Pictorial No. 71, N., 1000	16338
VITAGRAPH—The Mystery of Brayton Court, D., 1000	16336

Tuesday, November 3, 1914.

BIOGRAPH—Masks and Faces, D., 2073.....	16349
COLUMBUS—A Twisted Affair, C., 1000.....	16347
EDISON—Shorty, D., 1000.....	16340
ESSANAY—Fires of Fate, D., 1000.....	16342
KALEM—Lizzie, the Life Saver, C., 1000.....	16348
LUBIN—A Boomerang Swindle, C., 1000.....	16346
SELIG—The Telltale Knife, D., 1000.....	16343
VITAGRAPH—On the Stroke of Five, D., 2000....	16244

Wednesday, November 4, 1914.

EDISON—Jenks and the Janitor, C., 500.....	16351
Buster Brown Picks Out the Costumes, C., 500.	
ESSANAY—The Fable of "How Uncle Brewster Was Too Shifty for the Tempter," C., 1000...	16354
KALEM—The Prison Stain, D., 2000.....	16352
LUBIN—The Sorceress, D., 2000.....	16357
SELIG—"C. D.," D., 1000.....	16356
VITAGRAPH—The Evolution of Percival, C., 1000.	16355

Thursday, November 5, 1914.

BIOGRAPH—Butterflies and Orange Blossoms, C., 998	16359
ESSANAY—Slippery Slim and the Impersonator, C., 1000	16360
LUBIN—The Stolen Yacht, D., 2000.....	16361
SELIG—Hearst-Selig News Pictorial No. 72, N., 1000	16364
VITAGRAPH—The Choice, D., 1000.....	16263

Friday, November 6, 1914.

BIOGRAPH—A Regular Rip, C., 476.....	16373
Getting the Sack, C., 523.....	
EDISON—The Pines of Lorey, D., 2000.....	16365
ESSANAY—His Dearest Foes, D., 2000.....	16367
KALEM—The Indian Suffragettes, C., 1000.....	16366
LUBIN—Love Triumphs, D., 1000.....	16372
SELIG—No Wedding Bells for Her, C., 1000.....	16370
VITAGRAPH—Thanks for the Lobster, C., 1000..	16371

Saturday, November 7, 1914.

BIOGRAPH—The Dole of Destiny, D., 996.....	16380
EDISON—Getting to the Ball Game, C., 1000.....	16374
ESSANAY—Broncho Billy's Mission, D., 1000.....	16375
KALEM—The Men in the Vault, D., 1000.....	16379
LUBIN—Kidnapping the Kid, C., 400.....	16376
The Honor of the Force, C., 600.....	
SELIG—The Losing Fight, D., 1000.....	16381
VITAGRAPH—In the Land of Arcadia, D., 2000..	16377



**THE
SIMPLEST
THE
BEST
BURNS 'EM
SHORTEST**

WEBB'S CARBON SAVER

Extra heavy and best material used throughout
Cut is one half actual size
PRICE \$1.00 EACH PREPAID
Give size of carbons used when ordering
MOTION PICTURE SPECIALTY & REPAIR CO.
326 3d Ave. Pittsburgh, Pa.

Moving Picture Scenarios

We are in the market for one and two reel comedies and comedy dramas.

Submit in typewritten form to

J. C. BROWNELL
105 Lawrence Avenue, Dept. C,
Dorchester, Mass.

Holland Film Manufacturing Co.

A. I. Runyon Advertising & Sales Co., Inc., Successors to



Acme Commercial Film Co.

Prices to the Trade
POSITIVE PRINTS .04 1/2 Per Foot
(In Quantities over 5000 feet)

Above price includes printing, developing, tinting, fuming and Raw Positive
Negative Film Developed .01 Per Ft.
Film Titles .08 " " "

(Our Special Title Apparatus will match any perforation.) All work guaranteed.
General Offices 2624 Milwaukee Ave., Chicago
Phone Albany 3125

YOU ARE TO BLAME

if you don't get "Motion Picture News" every week. Use your pencil and fill in the subscription blank NOW.

LANG'S FILM REELS
THE BEST MADE

14 in. \$1.50 10 in. \$1.00

CATALOGUE
LANG MFG. WORKS, Orleans, N. Y.

"SALOMY JANE" AT BROADWAY THEATRE

Fifteen hundred invitations were issued by President Walter Hoff Seely and the directors of the Alco Film Corporation for a private exhibition of "Salomy Jane" at the Broadway Theatre on Tuesday, October 27, at 10 a. m. The invitations were sent to prominent film men within a large radius of Greater New York, to writers, artists, professional people and persons prominent in the life of the metropolis.

When "Salomy Jane" was shown in a similar way to the leading men and women of San Francisco at the St. Francis Hotel, the film drama was received with great approbation. "Salomy Jane" is based upon Paul Armstrong's dramatization of Bret Harte's "Salomy Jane's Kiss." It is the first attempt to present the atmosphere of California as Bret Harte saw it, in the picture film.

23 WEEKS' RUN IS KELLERMAN FILM RECORD

Special to MOTION PICTURE NEWS

Chicago, October 21.

Alfred Hamburger becomes the proud possessor of the world's record for continuous exhibition of a photoplay.

For the past twenty-three weeks he has been showing the graceful Annette Kellerman at the Fine Arts Theatre in Chicago to a patronage estimated at 200,000 people.

During the last four weeks several big features sought a location in Chicago for a downtown run, but none of them could guarantee to beat the box-office receipts produced by the fair Australian.

CLAWSON AND HILL PHOTOGRAPH "HYPOCRITES"

Two camera men filmed Bosworth's "Hypocrites," George W. Hill and Dallin Clawson. A previous statement only gave credit to Mr. Hill, who, incidentally, is the personal photographer of Hobart Bosworth.

Dallin Clawson has been the camera man of the company for two years, and the concern feels that credit for the remarkable photography in this picture should be given to him as well as Mr. Hill.

Mr. Siegel, the Photo Drama Company's representative in Ohio, Michigan, and Western Pennsylvania, reports that over five thousand persons witnessed "After the Ball," at the Majestic Theatre, Erie, Pa., when the picture was shown there on October 8, 9 and 10.

Unfortunately on the last day of the showing it rained continuously, and this is responsible for a return date.

Make Your Lobby Display Attractive

There is nothing more fascinating to the public than a bright brass frame to display your photos or posters.

We make Lobby and Theatre Fixtures and Brass Rails of every description.

Don't fail to visit our Showrooms.

Write for catalog.

THE NEWMAN MFG. CO.

717 Sycamore St.

Cincinnati, Ohio

Branch Factories and Show Rooms:

101 Fourth Ave.

New York, N. Y.

106-108 W. Lake St.

Chicago, Ill.

Established 1882.



COMPENSARC

That's the device that saves Moving Picture men two-thirds of their electric light bills, and yet gives better light. Did you see our ad last week? Well, don't look it up. Just write for our

Booklet 5027

FORT WAYNE ELECTRIC WORKS
OF GENERAL ELECTRIC CO.
1704 BROADWAY
FORT WAYNE INDIANA 733

Your negative developed, printed and titled complete

5c per foot delivered within **12** hours
Titles **6c** per foot

GUNBY BROS., Inc.
145 West 45th Street New York City

ALL STAR FEATURES

CHARLES A. STEVENSON
in
"SHORE ACRES"
James A. Herne's Masterpiece
In Five Parts.
RELEASED OCT. 26.

Coming
DIGBY BELL
in
"The Education of Mr. Pipp"
TO BE RELEASED N. V. 26.

All Star Feature Corp.
220 West 42d Street New York

Manufacturers of the Wonderful
Rembusch Patented Glass **MIRROR SCREEN**
and all other kinds of
Curtains for Moving Picture Projection

GLASS SCREENS
Mirror Screen
Mirror Screen Split
Glass Transparent Screen for Rear Projection

METALLIZED SCREENS
Gold Fibre
Silvercloth
Mirror Cloth
Seamless, with stretchers
White Opaque

MIRROR SCREEN COMPANY
Incorporated
SHELBYVILLE, INDIANA

Mr. O. P. Sammons of Denison, Texas, bought a "Mirror Screen," and he writes that he cannot take care of the crowds. His picture is simply the talk of the community. A few second-hand screens for sale cheap.
Eastern Representative, Frank Manning, 125 W. 48th St., N. Y. Phone. Bryant 2416.

Phone Seven-Eleven F. J. REMBUSCH, Pres.

RECORD OF CURRENT AND COMING RELEASES—Continued

UNIVERSAL PROGRAM

RELEASES OF THE WEEK

Monday, October 26, 1914.

IMP—Marie's Patients and Educational.....
STERLING—Snoopee's Day Out, C., 1000.....
VICTOR—Terrence O'Rourke No. 1, His Heart,
His Hand, His Sword, D., 2000.....

Tuesday, October 27, 1914.

CRYSTAL—Persistent Lovers, C.....
GOLD SEAL—The Trey O' Hearts, Episode
No. 13, D., 2000.....
NESTOR—The Wall of Flame, D.....

Wednesday, October 28, 1914.

ANIMATED WEEKLY—No. 138, N.....
ECLAIR—The Mystery of Grayson Hall, D., 2000.
JOKER—Noads Adless Day, C.....

Thursday, October 29, 1914.

IMP—In Self-Defense, D., 2000.....
REX—White Roses, D.....
STERLING—A Race for a Bride, C., 1000.....

Friday, October 30, 1914.

NESTOR—When Bess Got in Wrong, C.....
POWERS—The Senator's Lady, D.....
VICTOR—The Witch Girl, D., 2000.....

Saturday, October 31, 1914.

101 BISON—A Daughter of the Red Skies, D.,
2000

JOKER—When Their Wives Joined the Force, C..
FRONTIER—The Blacksmith's Daughter, D.....

Sunday, November 1, 1914.

ECLAIR—At the Crucial Moment, D., 1000.....
L-KO—Partners in Crime, C.....
REX—The Vagabond, D., 2000.....

RELEASES OF NEXT WEEK

Monday, November 2, 1914.

IMP—Millionaire Engineer, D. 3000.....
STERLING—The Wall Between, C.....
VICTOR—Mary Fuller in His Big Chance, D.....

Tuesday, November 3, 1914.

CRYSTAL—They Didn't Know, C.....
GOLD SEAL—The Trey O' Hearts, No. 14.....
NESTOR—The Star Gazer, D.....

Wednesday, November 4, 1914.

ANIMATED WEEKLY—No. 139, N.....
ECLAIR—The Return, D., 2000.....
JOKER—The Hoodoo, C.....

Thursday, November 5, 1914.

IMP—The Universal Boy in "The Mystery of the
New York Docks".....
REX—Let Us Have Peace, C. 2000.....
STERLING—Dot's Chaperone, C.....

Friday, November 6, 1914.

NESTOR—Those Were the Happy Days, C., 2000.
POWERS—Man of the Hills, D.....
VICTOR—Tale of a Lonesome Dog, C.....

Saturday, November 7, 1914.

101 BISON—The Junglemaster, 2000.....
FRONTIER—The Girl from Texas, D.....
JOKER—Two Pals and a Gal, C.....

Sunday, November 8, 1914.

ECLAIR—At the Crucial Moment, 1000.....
L-KO—The Fatal Marriage, C.....
REX—The Link That Binds, D., 2000.....

MUTUAL PROGRAM

RELEASES OF THE WEEK

Monday, October 26, 1914.

AMERICAN—Sir Galahad of Twilight, D., 2000....
KEYSTONE—Shot in the Excitement, C., 1000....
RELIANCE—Our Mutual Girl No. 41.....

Tuesday, October 27, 1914.

BEAUTY—A Rude Awakening, C.....
MAJESTIC—A Mother's Influence, D.....
THANHOUSER—A Madonna of the Poor, D.,
2000

Wednesday, October 28, 1914.

AMERICAN—Sweet and Low, D.....
BRONCHO—The Golden Goose, D., 2000.....
RELIANCE—Sheriff for an Hour, D.....

Thursday, October 29, 1914.

DOMINO—Eric the Red's Wooing, D., 2000.....
KEYSTONE.....
MUTUAL WEEKLY—No. 96.....

Friday, October 30, 1914.

KAY BEE—The Worth of a Life, D., 2000.....
PRINCESS—The Dead Line, C.....
RELIANCE—The Availing Prayer, D.....

Saturday, October 31, 1914.

KEYSTONE.....
RELIANCE—The Wrong Prescription, D., 2000...
ROYAL—Phil's Vacation, C.....

Sunday, November 1, 1914.

KOMIC—Casey's Vendetta, C.....
MAJESTIC—Paid with Interest, D., 2000.....
THANHOUSER—Shep's Race with Death, D.....

RELEASES OF NEXT WEEK

Monday, November 2, 1914.

AMERICAN—The Ruin of Manley, D., 2000.....
KEYSTONE—Lovers' Post Office, C., 1000.....
RELIANCE—Our Mutual Girl No., D.....

Tuesday, November 3, 1914.

BEAUTY—The Tightwad, C.....
MAJESTIC—False Pride, D.....
THANHOUSER—The Turning of the Road, D.,
2000

Wednesday, November 4, 1914.

AMERICAN—When the Road Parts, D.....
BRONCHO—The Desperado, D.....
RELIANCE—The Miner's Peril, D.....

Thursday, November 5, 1914.

DOMINO—In Old Italy, D., 2000.....
KEYSTONE—Curses, They Remark'd, C., 1000..
MUTUAL WEEKLY—No. 97.....

Friday, November 6, 1914.

KAY BEE—In the Clutches of the Gangsters, D.,
2000

PRINCESS—When Vice Shatters, C.....
THANHOUSER—The Chasm, D.....

Saturday, November 7, 1914.

KOMIC—Ethel's Roof Party (Bill No. 10), C.....
MAJESTIC—The Tear That Burned, D., 2000.....
THANHOUSER—Keeping a Husband, C.....

PERFECT DEVELOPING AND PRINTING

For Amateurs and Professionals in Any Quantities

**We Guarantee Quality Plus Prompt Delivery
and Personal Service**

Our unexcelled facilities, complete factory equipment, special service bureau, combined with our experience and successful record extending over a period of more than four years, qualifies us to best serve you.

Prices, References and Factory Description Sent at Your Request

We Supply Fresh Eastman Negative

to our customers as a matter of accommodation and guarantee to make shipment same day order is received. All film stock guaranteed highest grade with perfect Bell & Howell perforations.

INDUSTRIAL MOVING PICTURE COMPANY

WATTERSON R. ROTHACKER, General Manager

223-233 West Erie Street

CHICAGO

Sawyer War Films Cover Wide Field

Scenes Representing Activities in Austro-Servian Campaign, French Naval Events, Greek Mobilization, and Engagement Near the River Dema

SAWYER, INC., worked night and day in order to release on October 19 its "The Only Authentic Films of the War in Europe." The Sawyer office has made no previous announcements, but ever since the beginning of hostilities it has been arranging to secure actual war pictures. The negatives just arrived, and in them is sufficient "live" matter to make either three or four reels, it is said. This absence of "padding" certainly is a feature which will make a strong appeal to the motion picture public.

The Austro-Servian campaign was cinematographed by the royal command of His Majesty King Peter of Servia, the French naval scenes by a French officer, and the Russian operations by an imperial court photographer, with the Czar's permission, it is asserted. Scenes showing the Greek mobilization were made by permission of King Constantine, and Turkish war preparations by authority from the Sultan Mohammed, it is declared.

The films have a thrill from start to

finish, although the photography is by no means perfect. Considering the conditions under which they were taken, often at the risks of the camera men's lives, the results are said to be remarkable.

The views of the Servian campaign are said to show all the events from the declaration of war on July 28. King Peter and his staff attend cathedral service to pray for success before going to the front, where the films show him received by the assembly of officers. The engagements near the River Dema and the battle of Shabatz are also said to be shown.

King Nicholas of Montenegro personally leads his troops to the aid of Servia. Naval scenes taken by a French officer show the bombardment of Cattaro, Austria, by the French. By way of Holland a short film showing Russian operations came through, it is said. Mobilization scenes in Greece and Turkey complete the picture.

The pictures present a vivid idea of the dreadful conditions in the war zone.

ROLL TICKETS Specially Printed and Absolutely Guaranteed
Cash with order. No C. O. D. at these prices.
50,000 for \$5.40 200,000 for \$15.30
30,000 for 4.50 100,000 for 9.00
Write for Samples and Prices on other Quantities.
400 S. 10th St. OMAHA, NEB. **REES TICKET CO.**

**BE UP TO DATE
INSTALL CORCORAN TANKS**

Get No. 6 Price List

A. J. CORCORAN, Inc.

9½ John Street

New York

One Exhibitor Nearly Starved

before he could make his theatre pay. Today he is one of the most successful theatre owners in the Central West.

His experience, and those of many others, who had to fight every inch of their way to success, form an interesting and PERSONALLY helpful feature of every issue of Motion Picture News.

The surest way to get each issue of this publication is to become a subscriber. The rate is exceptionally low—Two dollars a year. Just attach this advertisement to a bill, check or money order for that amount, and mail it to

The Sales Division

MOTION PICTURE NEWS

220 West Forty-Second Street, New York City

RELEASE DATES FOR READY REFERENCE

GENERAL FILM PROGRAM

BIOGRAPH

- 10-26. The Squashville School, C..... 540
- The Villainous Uncle, C..... 466
- 10-27. The Ticket-of-Leave Man, D.....2027
- 10-29. The Wife's Stratagem, D..... 999
- 10-30. The Tides of Sorrow, D..... 997
- 10-31. Hearts of Gold, D..... 999
- 11- 2. All for Business, D..... 997
- 11- 3. Masks and Faces, D.....2073
- 11- 5. Butterflies and Orange Blossoms, C..... 998
- 11- 6. A Regular Rip, C..... 476
- Getting the Sack, C..... 523
- 11- 7. The Dole of Destiny, D..... 996
- 11-10. The New Magdalen, D.....2073

COLUMBUS

- 10-13. Why Snakeville Went Dry, C....1000
- 10-20. Love Charm, C.....1000
- 10-27. Mulligan's Ghost, C.....1000
- 11- 3. A Twisted Affair, C.....1000

EDISON

- 10-27. The Mystery of the Sealed Art Gallery, D.....1000
- 10-28. The Lost Melody, D.....1000
- 10-30. The Midnight Ride of Paul Revere, D.....2000
- 10-31. The Hand of Iron, D.....1000
- 11- 3. Shorty, D.....1000
- 11- 4. Jenks and the Janitor, C..... 500
- Buster Brown, C..... 500
- 11- 7. Getting to the Ball Game, C.....1000
- 11- 9. With Slight Variations, C.....1000
- 11-10. The Heritage of Hamilton Cleek, D.....1000
- 11-13. A Question of Identity, D.....2000
- 11-14. The Everlasting Triangle, D.....1000
- 11-16. The Adventures of the Lost Wife C.....1000
- 11-17. A Moment of Madness, D.....1000
- 11-18. Buster Brown and the German Band, Cart..... 400
- A Millinery Mix-Up, C..... 600
- 11-20. What Could She Do? D.....3000
- 11-21. Dickson's Diamonds, D.....1000
- 11-23. His Chorus Girl Wife, D.....1000
- 11-24. A Gypsy Madcap, D.....1000
- 11-25. The Temple of Moloch, D.....1000
- 11-27. The King's Move in the City, D.....2000
- 11-28. The Last of the Hargroves, D.....1000
- 11-30. Wood B. Wedd Goes Snipe, C....1000

ESSANAY

- 10-31. Broncho Billy's Mother, D.....1000
- 11- 2. The Laundress, C.....1000
- 11- 3. Fires of Fate, D.....1000
- 11- 4. The Fable of "How Uncle Brewster Was Too Shifty for the Tempter," C.....1000
- 11- 5. Slippery Slim and the Impersonator, C.....1000
- 11- 6. His Dearest Foes, D.....2000
- 11- 7. Broncho Billy's Mission, D.....1000
- 11- 9. Sweedie the Trouble Maker, C.....1000
- 11-10. Within Three Hundred Pages, D.....1000
- 11-11. Three Boiled Down Fables, C.....1000
- 11-12. Sophie and the Man of Her Choice, C.....1000
- 11-14. Broncho Billy's Decision, D.....1,000

KALEM

- 10-31. The Vengeance of Winona, D...1000
- 11- 2. His Inspiration, D..... 1000
- 11- 3. Lizzie, the Life Saver, C..... 2000
- 11- 4. The Prison Stain, D..... 2000
- 11- 6. The Indian Suffragettes, C..... 1000
- 11- 7. The Man in the Vault, D..... 1000
- 11- 9. The Riddle of the Green Umbrella, D..... 1000
- 11-10. The Widow's Might, C..... 2000
- 11-11. A Mid-ight Tragedy, D..... 2000
- 11-13. Ham, the Piano Mover, C..... 1000
- 11-14. Helen's Sacrifice, D..... 2000
- 11-16. The Man of Iron, D.....2000
- 11-17. The Peach at the Beach, C..... 1000
- 11-18. His Nemesis, D..... 1000
- 11-21. The Plot at the R. R. Cut, D..... 1000
- 11-23. The Theft of the Crown Jewels, D..... 1000
- 11-24. Tough Luck Smith, C..... 1000
- 11-25. The Girl and the Explorer, C....2000

- 11-27. Ham the Iceman, C..... 1000
- 11-28. The Girl at the Throttle, D..... 1000
- 11-30. Her Bitter Lesson, D.....2000

KLEINE

- 9-29. A Shot from Ambush, D.....2000
- 10- 6. The Wrecked Special, D.....2000
- 10-13. On the Battle Line, D.....2000

LUBIN

- 11- 3. The Boomerang Swindle, C.....1000
- 11- 4. The Sorceress, D.....2000
- 11- 5. The Stolen Yacht, D.....2000
- 11- 6. Love Triumphs, D.....1000
- 11-14. Kidnapping the Kid, C..... 400
- The Honor of the Force, C..... 600
- 11- 9. The Beloved Adventurer, Series No. 9, D.....1000
- 11-10. Butt-Ing In, C..... 400
- A Bargain Table Cloth, C..... 600
- 11-11. The Quack, D.....2000
- 11-12. In the Hill of Kentucky, D.....2000
- 11-13. The Trap, D.....1000
- 11-14. Beating the Burglar, C..... 400
- Magazine Cooking, C..... 600
- 11-16. The Beloved Adventurer, No. 10, D.....1000

RELEASE DAYS

GENERAL FILM PROGRAM

- Monday—Biograph, Edison, Essanay, Hearst-Selig News Pictorial, Kalem, Selig, Vitagraph.
- Tuesday—Columbus, Edison, Essanay, Geo. Kleine, Lubin, Selig, Vitagraph.
- Wednesday—Edison, Essanay, Kalem, Lubin, Selig, Vitagraph.
- Thursday—Biograph, Essanay, Hearst-Selig News Pictorial, Lubin, Selig, Vitagraph.
- Friday—Edison, Essanay, Kalem, Selig, Lubin, Vitagraph.
- Saturday—Biograph, Edison, Essanay, Kalem, Lubin, Vitagraph, Selig.

UNIVERSAL PROGRAM

- Monday—Victor, Imp, Powers.
- Tuesday—Gold Seal, Crystal, Nestor.
- Wednesday—Nestor, Joker, Eclair, Animated Weekly.
- Thursday—Imp, Rex, Frontier, Sterling.
- Friday—Nestor, Powers, Victor.
- Saturday—Joker, Frontier, 101 Bison.
- Sunday—Rex, Crystal, Eclair, L-KO.

MUTUAL PROGRAM

- Monday—American, Keystone, Reliance.
- Tuesday—Beauty, Majestic, Thanouser.
- Wednesday—American, Broncho, Reliance.
- Thursday—Dominio, Keystone, Mutual Weekly.
- Friday—Kay-Bee, Majestic, Princess.
- Saturday—Keystone, Reliance, Royal.
- Sunday—Majestic, Komic, Thanouser.

- 11-17. She Was the Other, C..... 400
- Cheap Transportation, C..... 600
- 11-18. The Marriage Wager, D.....2000
- 11-19. On Suspicion, D.....2000
- 11-20. The Unknown County, D.....1000
- 11-21. The Tale of a Coat, C..... 400
- The Daddy of Them All, C..... 600
- 11-23. The Beloved Adventurer, No. 11, D.....1000
- 11-24. Mother's Baby Boy, C..... 400
- He Wanted Chicken, C..... 600
- 11-25. The Making of Him, D.....2000
- 11-25. Was His Decision Right? D.....2000
- 11-26. He Waits Forever, D.....1000
- 11-27. You Can't Beat Them, C..... 400
- The Servant Girl's Legacy, C..... 600

SELIG

- 10-19. Hearst-Selig News Pictorial No. 67, N.....1000
- 10-20. Jimmy Haves and Muriel, D.....1000
- 10-21. The Rajah's Vacation, C.....1000
- 10-22. Hearst-Selig News Pictorial No. 68, N.....1000
- 10-23. A Tonsorial Leopard Tamer, C.....1000
- 10-24. The Tragedy That Lived, D.....1000
- 10-26. Flaying with Fire, D.....2000
- 10-26. Hearst-Selig News Pictorial No. 69, N.....1000

- 10-27. Why the Sheriff Is a Bachelor, D.1000
- 10-28. The Wasp, D.....1000
- 10-29. Hearst-Selig News Pictorial No. 70, N.....1000
- 10-30. The Grate Impeeryul Sirkus, C.....1000
- 10-31. At the Transfer Corner, C.....1000
- 11- 2. Rosemary, That's for Remembrance, D.....1500
- 11- 3. The Telltale Knife, D.....1000
- 11- 4. "C. D." D.....1000
- 11- 5. Hearst-Selig News Pictorial, No. 72, N.....1000
- 11- 6. No Wedding Bells for Her, C.....1000
- 11- 7. The Losing Fight, D.....1000

VITAGRAPH

- 11- 2. The Mystery of Brayton Court, D.....1000
- 11- 3. On the Stroke of Five, D.....2000
- 11- 4. The Evolution of Percival, C.....1000
- 11- 5. The Choice, D.....1000
- 11- 6. Thanks for the Lobster, C.....1000
- 11- 7. In the Land of Arcadia, D.....2000
- 11- 9. Miss Tomboy and Freckles, C.....1000
- 11-10. The Separator's Brother, D.....2000
- 11-11. In Bridal Attire, C.....1000
- 11-12. Lola, the Rat, D.....1000
- 11-13. The Rocky Road of Love, C.....1000
- 11-14. Ann, the Blacksmith, D.....1362
- Making of a Newspaper, E..... 638
- 11-16. Sisters, D.....1000
- 11-17. Hope Foster's Mother, D.....2000
- 11-18. Fixing Their Dads, C.....1000
- 11-19. Too Much Burglar, C.....1000
- 11-20. The Professional Scapagoat, C.....1000
- 11-21. Mary Jane Entertains, C.....2000
- 11-23. The Level, D.....1000
- 11-24. The Old Flute Player, D.....2000
- 11-25. Netty or Letty, C.....1000
- 11-26. Cause for Thank-giving, C.....1000
- 11-27. The Curing of Myra May, C.....1000
- 11-28. Convict. Costumes and Confusion, C.....2000
- 11-30. Everything Against Him, D.....1000

UNIVERSAL PROGRAM

ANIMATED WEEKLY

- 10-28. No. 138, N.....
- 11- 4. Weekly No. 139, N.....
- 11-11. Weekly No. 140, N.....

101 BISON

- 11- 7. A Small Town Girl, D.....3000
- 11-14. The Silent Peril, D.....2000
- 11-21. The Ninety Black Boxes, D.....2000

CRYSTAL

- 10-20. Vivian's Transformation, C.....
- 10-27. Persistent Lovers, C.....1000
- 11- 2. They Didn't Know, C.....
- 11-10. The Life Saver, C.....

ECLAIR

- 10-21. The Vicar, D.....2000
- 10-25. Smallpox on the Circle U, D.....
- 10-28. The Mystery of Graysom Hall, D.2000
- 11- 1. At the Crucial Moment, D.....1000
- 11- 4. The Return, D.....2000
- 11- 8. At the Crucial Moment, D.....
- 11-11. The Yellow Streak, D.....2000
- 11-15. Her Own House, D.....

FRONTIER

- 10-18. In the Hollow of an Oak, D.....
- 10-24. The Scarecrow's Secret, D.....
- 10-31. The Blacksmith's Daughter, D.....
- 11- 7. The Girl from Texas, D.....
- 11-14. The School Teacher at Angel Camp, D.....

GOLD SEAL

- 10-27. The Trey o' Hearts, Episode No. 13, D.....2000
- 11- 3. The Trey O' Hearts, No. 14, D.....2000
- 11-10. The Trey o' Hearts, No. 15, D.....3000

**Your Operator
Can't Help It**

Neither can the maker of your glass announcement slides—they are bound to break!

Our Patented Brass Slides Are Absolutely Indestructible—cannot crack.

They project a neat, clear, easily read announcement, and will last for years.

More than 90 stock designs. Special slides to order.

Stock slides, 25 cents each.

For sale at all branches of the General Film Co., Inc., and all Mutual Film Co.'s Exchanges and all Live Dealers and Glass Slide Manufacturers.

BEHREND MOTION PICTURE SUPPLY HOUSE

440 Fourth Ave. Branch: 71 W. 23rd St.
New York City

SEND FOR COMPLETE LIST

Patented
Serial No.
757689



Stock Slides, 25c.

Patented
Serial No.
757689



Open
Space Slides, 35c.

Patented
Serial No.
757689



Clock Slides, 50c.

A clear picture

is as essential as a good scenario. Because the basic product is right the clearest pictures are on Eastman Film. Identifiable by the stencil mark in the margin.

EASTMAN KODAK CO.,
ROCHESTER, N. Y.

Warning to Exhibitors

KEYSTONE films have become so popular that unscrupulous dealers are at work again selling dupes throughout the country. The only genuine KEYSTONE films are those rented exclusively in the United States and Canada through the Mutual Film Exchanges. This Company will ferret out and prosecute and punish to the extent of the law, those duping KEYSTONE films or exhibiting dupes.

THE KEYSTONE FILM COMPANY A. KESSEL, Jr.
President
LONG ACRE BUILDING Broadway and 42nd Street NEW YORK CITY

RELEASE DATES FOR READY REFERENCE—Continued

IMP

10—15. The Futility of Revenge, D.....2000
 10—19. Country Innocence, D.....2000
 10—22. Universal Boy in "The Gates of Liberty"
 10—26. Marie's Patients, and Educational; split reel
 10—29. In Self-Defense, D.....2000
 11— 2. The Turn of the Tide.....2000
 11— 5. The Universal Boy in "The Mystery of the New York Docks"
 11— 9. The Stronger Love, Mary Pickford Reissue, D.....2000
 11—12. Peg of the Wilds, D.....2000

JOKER

10—10. Cruel, Cruel World, C.....
 10—14. On Again, Off Again, Finnigan, C.
 10—17. Across the Court, C.....
 10—21. The Countess Count, C.....
 10—28. Noads' Adless Day, C.....
 10—31. When Their Wives Joined the Force, C.....
 11— 4. The Hoodoo, and Educational....
 11—11. The Frankfurter Salesman's Dream, C.....
 11—14. Defeat of Father, and Educational, C.....

L-KO

11—15. Lizzy's Escape, C.....

NESTOR

10— 2. Out of the Frying Pan, C.....
 10— 7. The Old Bell Ringer, D.....
 10— 9. He Never Said a Word, C.....
 10—16. The Way of Life, D.....
 10—23. Cupid Pulls a Tooth, and Mt. St. Bernard, Switzerland; split reel.
 10—27. The Wall of Flame, D.....
 11— 3. The Boy Major, D.....
 11— 6. Those Were the Happy Days, C.....2000
 11—10. The Two Thieves, D.....
 11—13. When the Girls Were Shanghaied, C.....

POWERS

10— 9. The Mayor's Manicure, C.....
 10—16. The Padrone's Ward, D.....2000
 10—23. Suspended Sentence, C.....
 10—30. The Senator's Lady, D.....
 11— 6. Nan of the Hills, D.....
 11—13. Sissy Dohins' Oil Magnet, C.....

REX

10—15. Her Life's Story, D.....
 10—18. Kid Regan's Hands, D.....2000
 10—22. Olaf Erickson—Boss, D.....2000
 10—25. The Little Blond Lady, D.....
 10—29. White Roses, D.....
 11— 1. The Vagabond, D.....2000
 11— 5. Let Us Have Peace, C.....2000
 11— 8. The Link That Binds, D.....2000
 11—12. The Shoemaker's Eleventh, C.....
 11—15. The Chorus Girls' Thanksgiving, D.....2000
 11—19. His Uncle's Will, D.....2000

STERLING

10—29. A Race for a Bride, C.....1000
 14— 2. The Wall Between, C.....
 11— 5. Dot's Chaperon, C.....
 11— 9. An Ill Wind, C.....
 11—12. The Dog Raffles, C.....

UNIVERSAL IKE

10— 6. The Neglected Wife.....
 10—13. Mary Green's Husband, and Educational, C.....
 10—13. Mary Green's Husband, and The Monkey Caharet, C., split reel..

VICTOR

10—23. The Bride of Marble Head, D.....2000
 10—26. Terrence O'Rourke No. 1, D.....2000
 10—30. The Witch Girl, Mary Fuller, D.....2000
 11— 2. Mary Fuller in "His Big Chance," D.....
 11— 6. Tale of a Lonesome Dog, C.....
 11— 9. Terrance O'Rourke, Gentleman Adventurer, D.....2000
 11—13. Mary Fuller in "Girl of the People," D.....2000

MUTUAL FILM PROGRAM

AMERICAN

10—28. Sweet and Low, D.....1000
 11— 2. The Ruin of Manley, D.....2000
 11— 4. When the Road Parts, D.....1000
 11— 9. Red Bird Wins, D.....2000
 11—11. The Stolen Masterpiece, D.....1000
 11—16. Redbird Wins, D.....2000
 11—18. Beppo, D.....1000
 11—20. Old Enough to Be Her Grandpa, C.....1000

BEAUTY

10—13. Winsome Winnie, C.....1000
 10—20. Dad and the Girls, C.....1000
 10—27. A Rude Awakening, C.....1000
 11— 3. The Tightwad, D.....1000
 11—10. Motherhood, D.....1000

BRONCHO

10—28. The Golden Goose.....
 11— 4. The Desperado.....2000
 11—11. Destin's Night.....
 11—18. Shorty Falls Into a Title, C.....2000

DOMINO

10—22. The Power of the Angelus.....
 10—29. Eric the Red's Wooing.....
 11— 5. In Old Italy.....2000
 11—12. The Friend.....2000
 11—19. Nipped.....2000
 11—26. The Mills of the Gods.....2000
 12— 3. The Vigil.....2000

KAY-BEE

10— 9. The Sheriff of Muscatine.....2000
 10—16. The Word of His People.....2000
 10—23. The Spark Eternal.....2000
 10—30. The Worth of a Life.....
 11— 6. The Game of Life.....2000
 11—13. In the Clutches of the Gangsters.....2000

KEYSTONE

9—17. Bombs and Bangs, C.....
 9—19. Lover's Luck, C.....
 9—21. He Loved the Ladies, C.....1000
 9—24. The New Janitor, C.....1000
 9—28. Hard Cider, C.....1000
 10— 1. Killing Horace, C.....1000
 10— 3. Fatty Again, C.....1000
 10— 5. Their Ups and Downs, C.....1000
 10— 8. Hello Mabel, C.....1000
 10—10. Those Love Pangs, C.....1000
 10—12. Anglers, C.....1000
 10—15. High Spots on Broadway, C.....1000
 10—19. Dash, Love and Splash, and Santa Catalina Islands, split reel.....
 10—22. Love Siege, C.....1000
 10—24. Stout Heart but Weak Knees, C.....1000
 10—26. Shot in the Excitement, C.....1000
 10—26. Dough and Dynamite, C.....2000
 10—29. Gentlemen of Nerve, C.....1000
 10—31. Cursed by His Beauty C.....1000
 11— 2. Lovers' Post Office, C.....1000
 11— 5. Curses They Remark'd, C.....1000
 11— 7. His Musical Career, C.....1000
 11— 9. His Trysting Places, C.....2000

KOMIC

10—18. Dizzy Joe's Career.....
 10—25. Bill Joins the W. W. W.'s No. 9..
 11— 1. Casey's Vendetta.....
 11— 8. Ethel's Roof Party (No. 10)....
 11—15. Out Again, In Again.....
 11—22. Ethel Has a Steady (No. 11)....

MAJESTIC

10—13. The Warning.....
 10—16. Back to the Kitchen.....
 10—18. For Her Father's Sins.....2000
 10—20. Environment.....
 10—25. Paid with Interest.....2000
 10—27. A Mother's Influence.....
 11— 1. Paid with Interest.....
 11— 3. False Pride.....
 11— 8. The Tear That Burned.....2000
 11—10. The Niggard.....
 11—13. The Folly of Ann.....
 11—15. The Odalisque.....2000
 11—22. The Saving Grace.....2000

MUTUAL WEEKLY

10—17. No. 90.....
 10—24. No. 91.....
 11— 1. No. 92.....
 11— 8. No. 93.....
 11—15. No. 94.....
 11—22. No. 95.....
 10—27. No. 96.....
 11— 3. No. 97.....

PRINCESS

9—25. The Balance of Power.....
 10— 2. The Balance of Power.....
 10— 9. The One Who Cared, D.....
 10—16. The Touch of a Little Hand.....
 10—23. The Face at the Window.....
 10—30. The Dead Line.....
 11— 6. When Vice Shatters.....

RELIANCE

10— 5. Our Mutual Girl, No. 38.....
 10— 7. The Badge of Office.....2000
 10—10. The Tardy Canon Ball.....
 10—12. Our Mutual Girl (No. 39).....
 10—14. Bad Man Mason.....2000
 10—17. The Revenue Officer's Deputy.....2000
 10—19. Our Mutual Girl (40).....
 10—21. Out of the Deputy's Hands.....
 10—24. A Blotted Page.....2000
 10—26. Our Mutual Girl No. 41.....
 10—30. The Availing Prayer.....
 10—31. The Wrong Prescription.....
 11— 2. Our Mutual Girl No. 42.....
 11— 4. The Miner's Peril.....
 11— 7. A Woman Scorned.....
 11— 9. Our Mutual Girl No. 43.....
 11—14. The Floating Call.....

ROYAL

10—17. The Black Hand.....
 10—24. Harold's Toupee.....
 10—31. Phil's Vacation.....
 11— 7. Max's Money.....
 11—14. A Fortune in Pants.....
 11—21. Love Finds a Way.....

THANHOUSER

9—20. The Mettle of a Man.....
 9—22. The Varsity Race.....
 9—27. The Harvest of Regrets.....
 9—29. The Trail of the Love Lorn.....
 10— 4. A Dog's Love.....
 10— 6. The Cripple.....
 10— 9. The Benevolence of Conductor 786
 10—11. The Rescue.....2000
 10—13. The Diamond of Disaster.....2000
 10—18. Left in the Train.....
 10—20. Old Jackson's Girl.....2000
 10—25. Mr. Cinderella.....
 10—27. A Madonna of the Poor.....2000
 11— 1. Shep's Race with Death.....
 11— 3. The Turning of the Road.....
 11— 8. Keeping a Husband.....
 11—10. The Terror of Anger.....
 11—13. The Chasm.....
 11—15. The Man with the Hoe.....

LUBIN

A CONTINUATION OF "MASTERPIECE" SUCCESSES
EVERY EXHIBITOR SHOULD BOOK THESE BEAUTIFUL PICTURES
 (Through the General Film Special Service) CAPACITY HOUSES EVERYWHERE

WILLIAM ELLIOTT, Late Star of "Madame X" Company

in
"THE FORTUNE HUNTER"
 6 Reel Comedy By Winchell Smith Direction—Barry O'Neil

"MARAHA, THE PYTHONESS"
 3 Reel Drama By Clay M. Greene Direction—Joseph W. Smiley

"THE WEIGHT OF A CROWN"
 3 Reel Drama By M. B. Havey Direction—Harry C. Myers

By Arrangement with Fred Mace
EVELYN NESBIT THAW
 and her son, **RUSSELL WILLIAM THAW**, in

"THREADS OF DESTINY"
 5 Reel Drama By Wm. H. Clifford Direction—Joseph W. Smiley

READY FOR EARLY RELEASE
EDWIN ARDEN

in
 5 Reel Drama "EAGLE'S NEST" Direction—
 By Edwin Arden Romaine Fielding

RAYMOND HITCHCOCK In a 5 Reel Comedy Drama
 by Lawrence McCloskey
 Direction—George W. Terwilliger

"STONEWALL JACKSON'S WAY"
 3 Reel Drama By Emmett Campbell Hall Direction—Edgar Jones

ROSE COGHLAN
 And **ETHEL CLAYTON** in
"THE SPORTING DUCHESS"
 6 Reel Comedy Drama By Cecil Raleigh Direction—Barry O'Neil

SIX REGULAR RELEASES EACH WEEK



"THE BELOVED ADVENTURER"—Eighth of Series, Drama, Monday,	November 2nd
"A Partner to Providence" Tuesday,	November 3rd
"A BOOMERANG SWINDLE"—Comedy Wednesday,	November 4th
"THE SORCERESS"—Two Reel Drama Thursday,	November 5th
"THE STOLEN YACHT"—Two Reel Drama Friday,	November 6th
"LOVE TRIUMPHS"—Drama Saturday,	November 7th
"KIDNAPPING THE KID" { Split Reel Comedies	
"THE HONOR OF THE FORCE" Saturday,	



SPECIAL ONE, THREE AND SIX SHEET POSTERS.
 Lubin Manufacturing Company, Philadelphia, Pa. Chicago Office:
154 West Lake Street

"Flying A" and

American "Beauty" Films

"A SLICE OF LIFE"

A Sociological Drama of Great Intensity. Two Acts.
 Featuring **WINNIFRED GREENWOOD** and **ED COXEN**. Under direction
 of Thos. Ricketts. Release Monday, Nov. 9th, 1914.

AMERICAN "BEAUTY" FILMS, Featuring **MARGARITA FISCHER** and **HARRY POLLARD**
"MOTHERHOOD"
 A Superb Dramatization Depicting Remarkable Histrionic Ability. Release Tuesday, Nov. 10th, 1914.

"THE STOLEN MASTERPIECE"

A "Flying A" Feature with an all star cast. Tense and Thrilling. Release Wednesday, Nov. 11, 1914.



Distributed exclusively through the United States and Canada by the Mutual Film Corporation.

AMERICAN FILM MANUFACTURING CO. CHICAGO

RELEASE DATES FOR READY REFERENCE—Continued

FEATURE RELEASES

ALCO FILM CORPORATION

ALL STAR

10— 5. The Nightingale, D.....5 parts
10—19. Shore Acres.....5 parts

CALIFORNIA MOTION PICTURE CORP.

11— 2. Salomy Jane.....5 parts

LIFE PHOTO FILM CORPORATION

Sept. Captain Swift, D.....5 parts
Oct. The Ordeal, D.....5 parts
Dec. Springtime.....

POPULAR PLAYS AND PLAYERS

10—12. The Ragged Earl, D.....
10—26. Michael Strogoff, D.....5 parts

B. A. ROFEE PHOTO PRODUCTIONS

Nov. Rip Van Winkle.....5 parts

TIFFANY MOTION PICTURE CORP.

Heart of Maryland.....

ALLIANCE FILMS CORPORATION

EXCELSIOR FEATURE FILM CO.

11—23. When Fate Leads Trump.....

FAVORITE PLAYERS

11—16. The Man Who Couldn't Lose..

PROGRESSIVE MOTION PICTURE CO.

11— 2. McVeagh of the South Seas, D.5 parts

SELECT PHOTO-PLAY PRODUCING CO.

10—26. At the Old Cross Roads, D...5 parts

MASTERPIECE FILM COMPANY

11— 9. The Hoosier Schoolmaster.....5 parts

APEX

Sept. Queen of the Counterfeiters, D..4 parts
Oct. Called to the Front; or Europe at War, D.....3 parts

BOX OFFICE ATTRACTION CO.

9—28. The Square Triangle, D.....3 parts
Oct. The Criminal Code, D.....4 parts
Oct. The Woman He Wronged, D...4 parts

COSMOS FEATURE FILM CORPORATION

Lena Rivers, D.....5 parts
Hearts and Flowers, D.....5 parts

COSMOFOTOFILM CORPORATION

Aug. What a Woman Will Do, D.....4 parts
Sept. England's Menace, D.....3 parts
Oct. England Expects—, D.....

E. & W. TRANSFILM BUREAU

Oct. Modern Warfare, D.....6 parts

HEPWORTH-AMERICAN

Aug. The Girl from the Sky, C.....
8—29. The Chimes, D.....3 parts
The Terror of the Air, D.....2 parts
Sept. Creatures of Clay, D.....3 parts

HECTOR FILM CORPORATION

Sept. Born Again, D.....5 parts

KINETOPHOTE CORPORATION

Oct. Markia.....5 parts
Oct. Spirit of the Poppy.....6 parts
Nov. Span of Life.....

ECLECTIC FILM COMPANY

Perils of Pauline, No. 14, D.....
Colonel Heeza Liar in the Wilderness, C.....700
Strange Animals, E.....300
Pathé Daily News No. 62-1914, Top.
The Colonel's Wife, D.....
Pathé Daily News No. 63-1914, Top.
Pathé Daily News No. 64, Top...
Second Door Left, C.....
War Stricken Louvain, Topical...
Pathé Daily News No. 65, Top...
Oct. The Ticket of Leave Man, D...3 parts
Oct. The King of the Air, D.....3 parts
Oct. The Count That Took the Count,
C.....
Oct. The Warning, D.....3 parts
Oct. The Broken Promise D.....4 parts
Oct. Miss Cinderella, C.....

OZ FILM COMPANY

Oct. Patchwork Girl of Oz.....5 parts
Oct. His Majesty, The Scarecrow of Oz.5 parts
Nov. The Last Egyptian.....

PARAMOUNT PICTURES

BOSWORTH

10— 1. Pursuit of the Phantom.....5 parts
10—19. Hypocrites!.....4 parts
11—23. The Country Mouse.....4 parts

FAMOUS PLAYERS

10—26. Behind the Scenes.....5 parts
11— 9. Man from Mexico.....5 parts
11—30. Mrs. Black Is Back.....
12—21. Step Sisters, D.....5 parts
12—28. The Crucible, D.....5 parts
12—31. The Million, D.....4 parts

JESSE LASKY COMPANY

10—22. What's His Name?.....5 parts
11—16. The Rose of the Rancho.....5 parts
11—26. The Man from Home.....5 parts
12— 7. Ghostbreakers, D.....5 parts

LASKY-LIEBLER

12—24. Cameo Kirby, D.....5 parts

SMALLEYS

12—17. False Colors, D.....5 parts

PLAYGOERS FILM COMPANY

Oct. The Great Diamond Robbery, D..6 parts

PICTURE PLAYHOUSE FILM COMPANY, INC.

11— 2. For King and Country.....
11—10. The Last Dance.....
11—18. The Wild Flower.....
11—26. The Black Envelope.....
12— 2. Convict 555.....
12—10. Partners.....

RENOWNED PLAYERS

Sept. A Great Mistake, D.....5 parts

SAWYER, INCORPORATED

Sept. Tyranny of the Mad Czar, D....4 parts
Sept. Doc, D.....4 parts
Oct. Thirty Minutes in Melodrama, C..2 parts
Oct. The Factory Magdalen, D.....4 parts
Oct. The Volunteer Parson, D.....4 parts
Oct. The Detective Queen, D.....4 parts

WARNER'S FEATURES

Sept. The Price of Crime, D.....3 parts
Oct. Hunted Down, D.....
Oct. In the Duke's Power, D.....
Oct. Bess of the Blazing Sea, D.....
Oct. The Adventures of Kitty Cobb, D.
Oct. False Pride Has a Fall, C.....3 parts
Oct. The Hypnotic Violinist, D.....3 parts
Even Unto Death, D.....

WORLD FILM CORPORATION

9—14. Protea II, D.....5 parts
9—21. The Dollar Mark, D.....5 parts
9—28. Mother, D.....4 parts
The Man in the Cellar, D.....

ANIMATED SONGS

Imperial Motion Picture Co., New York
Latest Releases:

There's a Lonesome Little Girl in a Lonesome Little Town.
She Was My Dad's First Sweetheart.
Down Where the Old Road Turns.
Push It Along.
She's Just a Bird in a Gilded Cage.

Alterations and Improvements

J. Koenigstein, a merchant at Eminence, Ky., for several months has been "looking over" the motion picture theatre proposition and has decided to convert a large portion of his store room into a hall suitable for a film house. He has announced that the theatre will be well equipped in every particular with a first-class projection apparatus. The location in the heart of the town is a very favorable one, and as this will be Eminence's first picture theatre, it is believed it will be a hummer.

Mr. George H. Bauer, manager of the Lawrenceville Theatre, Lawrenceville, Ill., is renovating and enlarging his house. On account of the good business he has been doing Mr. Bauer is compelled to increase his seating capacity, and when the theatre is completed it will be very modern throughout.

The Y. M. C. A. building at the corner of Main and West Elm streets, Brockton, Mass., soon to be vacated by the association for their new building, has been leased for ten years by three Marion men. They are B. E. Waters, of the Marion Gas Company; Isaac

E. Miller and Charles Ripley, also of Marion. The assembly hall is to be fitted up and used as a motion picture theatre and will be ready about the middle of December.

Estimates are being received at the office of William E. Lehman, as architect, for the erection of an addition to the motion picture theatre at 583 Orange street, Newark, N. J., for Solomon Anshach. The new extension, which will involve an expenditure of about \$12,000, will consist of a one-story brick addition, 55 x 85 feet, to the rear of the present theatre.

Plans were filed yesterday for altering the moving picture theatre at 48 East Fourteenth street, New York City, through the block to 53 East Thirteenth street, at a cost of \$8,000. The property has been operated for years by the Automatic Vaudeville Company.

The space formerly occupied as the Palace of Sweets, at 303 Main street, Houston, Tex., is being remodeled for a film theatre. The playhouse when completed will be known as the Crown theatre, the house assuming the name of the manager, Peter C. Crown. The property was leased by John D. Polemanakos, of Houston, the lease dating from September

1 last and running for five years. After securing the property and the services of Mr. Crown, Mr. Polemanakos lost no time in putting workmen on the building and it is announced that the theatre will be ready for occupancy about October 1. The theatre proper will be 30 by 100 feet in dimension, and will have a seating capacity of 350 people. In its construction there will be no sacrifice of comfort for additional seating capacity. The interior decoration will be simple in its tones, but the lobby, to be finished in real Italian marble, will be elaborately attractive. The improvements on the theatre will cost approximately \$25,000.

"The Grand" moving picture theatre at La Grange, Ky., has been sold by Mr. R. E. Gumm to Mr. A. W. Vaughan, possession to be given on October 1. Since taking charge of the Grand last winter Mr. Gumm has given his patrons the highest class pictures on the market. Mr. Vaughan promises to keep them up to the present standard.

The Luna theatre at Mt. Union, Pa., has changed hands, H. S. Chambers being the proprietor. Vaudeville and motion pictures will be run in the theatre as in the past.

Clyma Erects Big Plant in California

New Company Incorporated for \$100,000 and Backed by Well Known Men in the "Golden West," Will Produce Elaborate Pictures of Popular Novels by Edmund Mitchell
—Buildings Have Latest Equipment

Special to MOTION PICTURE NEWS

Los Angeles, Oct. 27.

WITH a release through one of the well-established companies contracted; two years' program planned; scenarios prepared; costumes, props and scene sets almost ready; and a new studio with administration building, modern motion picture factory, stage, dressing rooms and other necessary buildings nearing completion, the Clyma Company, Inc., has begun the filming of its first subject.

The company, incorporated in July under the laws of California, is composed of Henry W. Keller, business man, president; W. L. Valentine, banker, vice-president; Jack Jevne, retail and wholesale grocer, vice-president; Edmund Mitchell, author, traveler and motion picture producer, general manager; and Fred L. Baker, manufacturer, and E. G. Kuster, attorney, directors. All are of Los Angeles. The company is a closed corporation with a paid-up capital stock of \$100,000.

The productions of the company will consist of five reel features, from the books by Edmund Mitchell, general manager, and published by Chatto and Winders, London. The first to be taken up will be "Lone Star Rush," a story of early days in the western part of United States.

Scenarios for others now prepared are "Temple of Death," "A Tale of Adventure in India," "The Outlaw of El Tejon," a typical pioneer western story, and others. For the past two years Mr. Mitchell was connected with the Melies company, and the last half of that period he spent in cruising about the Pacific Ocean.

He arrived here in May from China. He has written fourteen novels, and it is planned that all of these shall be filmed. It is the intention to produce quality and not quantity pictures, and six or seven weeks will be devoted to each subject.

The photography will be in charge of Rene Guissart, five years with the Eclair company in Paris, and for the past few months at Tucson.

Among those selected for the stock company are: Bob Fraser, formerly of Eclair; Charles Arling, late Pathé lead; Rupert Julian, successful English actor until recently featured in Universal productions; Gordon Sackville, formerly of Bosworth, and others. Millie Bright will play leads in some of the productions. The first picture will be released about December 1.

The plant of the company will occupy one city block and is located at 1025 Lillian Way, Hollywood. The property will be the most complete motion picture producing plant in California, when

entirely completed. The buildings are of the California bungalow type and the grounds are inclosed in an attractive manner.

The administration building is 30 x 50 feet, and besides the offices contains a 12 x 34 feet projection room, with fireproof projecting booth at one end and a 12 x 12 fireproof storage vault for films. The laboratory or factory is 30

x 82 feet and will be equipped with a Bell and Howell latest type printing machine.

The ventilation of this building is a particular feature, all air being filtered through cotton wool. The stage is 50 x 60, scene dock 16 x 50, and scenic artist's studio 10 x 50. There are twenty dressing rooms all connected with hot and cold water.

Flynn Discusses Secret Service Serial

Stories Will Demonstrate the Futility of Crime, and Its Prevention—Film Attractions Production in Twenty Episodes Promises to Be Unique

THE forthcoming Secret Service serial now being produced by the Film Attractions Company, Inc., and produced under the personal supervision of C. V. Henkel, promises to be unique in many respects. In place of drawing upon the imagination for materials, the scenario is developed from actual facts within the experiences of William J. Flynn, Chief of the United States Secret Service.

Chief Flynn being interviewed, stated that he has repeatedly been solicited to allow the production of his stories (which have appeared from time to time in leading papers and magazines) upon the screen, but until now refused all overtures, fearing that his name and title might be used to exploit mere sensationalism, and depict the various methods of committing crime.

"In my story," said the Chief, "I do not pretend or desire to preach a ser-

mon, but nevertheless, I have taken particular pains to demonstrate the futility of crime. The function of any police organization is to prevent crime, as well as to detect it after its commission, and throughout the adventures of the various Secret Service operatives in this story I have woven a romance based upon authentic incidents, realizing that the spectator requires more than a mere exposition of facts.

"I have every confidence that Mr. Henkel with his experience will do full justice to the material I have furnished him. I have taken the best of my experiences with the various kinds of lawlessness, including counterfeiting, smuggling, land frauds, violations of exclusion acts, coining, diplomatic intrigues, suppression of revolution, and incorporated them in the twenty episodes of which my photoplay story will consist."

United Film Service Program Is Complete

Warner's Features, Inc., Set November 8 as Day to Start New Series of Releases—Surprises Are Promised

ON Sunday, November 8, Warner's Features, Inc., will release the first films on its new United Program and from that date the releasing will be continuous.

The program, to be known as the United Film Service, is produced for Warner's Features, Inc., by the United Motion Picture Producers, Inc. This concern was organized several weeks ago especially for this purpose, some of the best producing companies in the business uniting to form the central company.

Ever since its organization the producers composing it have been working over-time turning out comedies, dramas, semi-comedies and Westerns. In order to keep up with the work of editing the films the Warner company was compelled to put up a double screen in its projection room and install another machine.

There are many unique ideas shown in the initial United releases. A notable comedy is "Prince Charlie," produced in Superba films. Charlie goes to sea, is shipwrecked on a cannibal island, and the cannibal princess falls in love with the castaway. Charlie is played by Charles De Forrest, the famous comedian.

"The Gypsy's Warning," a Premier drama, shows some unusual effects in both the story and the setting. A mirthful comedy-drama of the uncommon sort is "Reuben's Busy Day." This is a Luna film produced by Gilbert P. Hamilton's company. Some of the weirdest automobile stunts ever seen in motion pictures are successfully performed in this film. Another comedy of unusual character is "The Villain Still Pursued Her," produced in Starlight Films by the Mit-tenthal Studio.

The Form On The Opposite Page

has been designed to aid you in keeping a complete and immediately available record of your "shows." It is arranged for use with the two pages each of "Release Dates for Ready Reference" and "Record of Current and Coming Releases" in every issue.

The chart will occupy one full page in each issue. You can remove it, carry it around in your pocket for the week and then place it in a loose leaf file for future reference on "repeaters," special features, posters, etc.

What Several News Readers Think of It

I am certainly delighted with your idea and can suggest no improvement on it.—Wm. B. Klahre, Ideal Theatre, Johnston, Pa.

I think your form for theatre record very good.—Chas. P. Hoffman, Star Theatre, Carrollton, Ohio.

The sheet shows careful study of the subject and devling into detail. Is a perfect record.—F. K. Hogan, Mgr., Coliseum Amusement Co., Coliseum Theatre, Toledo, Ohio.

We think this an excellent idea, as it will make quite a novel record as well as a great aid in repeaters.—Murray E. Hall, Dixie Play-House, Fellsmere, Fla.

No chance for improvement, good idea. Something every exhibitor should appreciate.—Jas. O'Malley, Ferguson Theatre, Olyphant, Pa.

In our opinion it is all O. K. and would like to have it in book form.—Savoy Theatre Co., Savoy Theatre, Washington, D. C.

It fills a want that all could use who like a system of doing things.—Fred E. Duffy, Hibernian Hall Theatre, Utica, N. Y.

I certainly think it a fine addition to your most valued "News." The News is certainly our best friend every week.—Glenn W. Reynolds, Princess Theatre, De Kalb, Ill.

It is very cleverly gotten up and think it very useful to an exhibitor. Thank you for same.—W. O. Marshman, Palms Theatre No 1, Indianapolis, Ind.

How to Use It

☐ The outside left hand column, headed "Day and Date," is to be filled in, under the name of each day, with the date and month.

☐ The column headed "Titles of Films Booked" has room for seven subjects every day of each week, with a subject to a line.

☐ The next column, headed "Release Date," is to enable you to check up and determine whether you are getting right films. An example: Your exchange should send you twenty-day Biographs. "The Lost Pearl," a Biograph single reel, is booked to you on Monday, September 14. By referring to the list of Biograph releases on the page of "Release Dates for Ready Reference" in The News for two or three issues back, you can find the title of the film, and the date of release. Then you know exactly how old it is when you get it.

☐ The column headed "Brand" is to simplify the identity of the releases when you have occasion to refer to the weekly charts at later dates.

The column headed "No. Reels" is necessary to some exhibitors, but not to all. Its use depends upon what manner of service you are booking.

☐ The column headed "Review Appears in Motion Picture News of" you can use either as an immediate guide to the page to familiarize yourself with the story of the film; or to use the review as a basis for booking; to have the story for instant use in your house organ, newspaper advertising, or for the news columns of the papers' motion picture department. The two sub-headings "Issue" and "Page" make the reference easier.

☐ The column headed "Posters used and size," if you note the amount of paper used each day, is a check on your paper bill, and a guide to the styles of paper you will get with your bookings.

☐ The column headed "Regular or Special" is for you to make a note of each film booked as a special.

☐ The next column, headed "Cost," applies only to special films. This gives you an automatic check at the end of each week on the total sum spent for outside features, or special films, and enables you to estimate their earning power when compared with receipts either for the day or week. It also helps you to establish a record of what various features are worth in rentals or on a percentage basis.

☐ The column headed "Advertising used; newspapers; heralds; slides; photographs; window cards, etc.," if filled in each day, will help you in determining just how much your various forms of advertising increase your patronage. The same is true of heralds, and all other publicity matter. Such a record, on these charts, will be mighty valuable after a few months.

☐ The column headed "Weather" will help you in analyzing your total gross receipts each day. In some places weather has considerable to do with patronage.

☐ The last column, headed "Total Admissions," with the two sub-headings, "Matinee" and "Night," will give you a positive record of the pulling value of different kinds of film. It will show just what profit there is in all of the other items mentioned on the chart. It will act as the final check on every one of them, and by comparison for several days or weeks, it will prove to you, beyond all doubt, just what certain brands are worth, what size posters "pull them in," what special features can do to boost business, whether newspaper advertising, heralds, slides or window displays are the most effective.

☐ By keeping this chart up to date each week, you will have a complete index to your business. A new one will be issued in every number of The News. Each one can be torn out and carried in your pocket for the week it is used, and then filed in a loose leaf binder for future reference.

Day and Date	Titles of Films Booked	Release Date	Brand	No. Reels	Review appears in Motion Picture News of		Posters Used and Size	Regular or Special	Cost	Advertising Used: Newspapers, heralds, slides, photographs, window cards	Weather	Total Admissions	
					Issue	Page						Matinee	Night
MONDAY													
Remarks													
TUESDAY													
Remarks													
WEDNESDAY													
Remarks													
THURSDAY													
Remarks													
FRIDAY													
Remarks													
SATURDAY													
Remarks													
SUNDAY													
Remarks													

"THE NAKED TRUTH"

(George Kleine—Five Reels)

REVIEWED BY C. J. VERHALEN

WITH some pictures it's the photography, with others it's the story, while others still stand out because of the situations. "The Naked Truth," however, is a big film because of the splendid acting of Lyda Borelli.

Her personality is infused in every bit of playing she does. Her prettiness lends an added charm to her work, and the play itself seems to have been wound around this actress, or it might be said she has wound the play around herself. This production marks her a photoplay actress of remarkable ability, one that is bound to stand out in the photoplay world as one of the biggest stars of the decade.

Without a doubt in her own country her name is blazoned forth from every theatre as an inducement for pictures fans to witness pictures in which she appears. The thing that makes her acting good is the simplicity with which it is done. She does not attempt to overplay any part, she merely bubbles over with the pleasure of living; then again in her moments of trial you know that she actually feels the part. There is no sham in that acting; she plays up to it, not with a rush, but with a delicacy that must be admired. One especially pretty piece of acting is her awakening scene. It is not done with an effort, but slowly, naturally and truthfully. She does it so well that you feel as though you are intruding.

The play itself is very good. It deals with a delicate subject, but gets away with it well. It contains a thread of interest that travels throughout it, and winds up with a finish that is different, but still satisfying.

In the Latin quarters of Paris Lolette lives, and is known throughout the artist's colony as the handsomest girl in Paris. She poses for Armand Bouchard, only because he befriended her. Pierre Bernier, a close friend of Bouchard, sees all his efforts go to waste because of the lack of a suitable model. He persuades Bouchard to consent to his employing Lolette.

During the days that follow while his masterpiece is in making a passionate love affair springs up between him and his model. Their marriage quickly follows. The picture wins the grand prize, is sold for a big sum and the couple move to a fashionable part of the city, and Bouchard is forgotten.

As his prosperity increased, Pierre becomes more and more ashamed of his wife's humble origin. He later becomes entangled in a love affair with the Princess Dupont. Lolette suspects, and when finally she surprises the pair alone she is certain that she has lost her husband's love.

She appeals to the aged prince, her rival's husband. He refuses aid, telling her that arrangements have been made for a divorce. She then decides to appeal directly to the woman. For a moment the princess' heart is touched, and she promises to break with Pierre.

Her resolution is short lived, and it is not long before she breaks her promise. She again appeals to her rival but without success. She announces her intention of securing a divorce and hurries home. That evening Pierre finds her lying half dead on the floor, the butt of a revolver clasped tightly in her hand.

Brought to their senses by Lolette's attempt on her own life, both Pierre and the princess resolve to end their liaison, and both promise her to make amends. The woman keeps her word, but the husband soon betrays his unworthiness. Heart-broken, Lolette sends him away, and when she has sufficiently recovered from her wound to leave her bed, she slowly makes her way back to the old studio in the Latin quarter tenderly led by the faithful Bouchard.

"THE PRICE HE PAID"

(Humanology—Five Reels)

REVIEWED BY CLIFFORD H. PANGBURN

THE producers of this picture describe it as "an illustration of the famous poem, 'The Price He Paid,' by Ella Wheeler Wilcox." Aside from the fact that the poem is not famous, and the picture has no particular connection with it, this statement is correct.

Regarded, not as a poem, but simply as a statement of an

idea, the verse in question has a certain merit, but as a basis for a motion picture scenario, it permits as much freedom of imagination as would Keats' "Ode to a Nightingale." This, one should hasten to add, is its only resemblance to anything ever written by Keats.

The picture belongs to the new school of pathological drama founded in this country by Richard Bennett, and in contrast to it the melodramas of a few years ago seem like the Rollo books. For obvious reasons, it is best not to attempt to tell the story here.

Suffice it to say that it is one which is meant to point a moral, but which fails to do so because of the ending. This makes it appear that the supposed victim is not a victim at all.

The marrying of the unfortunate girl to the physician may make a conclusion which is happy, in a manner of speaking, but it completely crushes such dramatic force as is present.

"YOUR GIRL AND MINE"

(Selig—Eight Reels)

REVIEWED BY C. J. VERHALEN

THE National American Woman Suffrage Association has caused eight reels of motion pictures to be made which are to make their silent argument for them over the entire country. In these eight thousand feet of pictures they have brought forth many arguments which cannot help but bring results because of the convincing manner in which they are set forth.

Undoubtedly these same arguments have been hurled forth from the platform time after time by the promoters of the cause, but never before have they had the convincing force that is contained in the pictures. While it was necessary to crowd all the wrongs into one life, it nevertheless made an interesting story. The impositions of the male of the species of course were manifold. One man could hardly do so many things and still be recognized by men. However, it was really necessary to use only one character in order to build a continuous story.

The purpose of launching the picture is to raise funds for the fight for the vote. They undoubtedly have chosen the strongest avenue they could secure.

The scenario was written by Gilson Willets and produced by William N. Selig for Mrs. Medill McCormick and the National American Woman Suffrage Association, and the arguments were furnished by Dr. Anna Howard Shaw.

A good cast of actors was employed to interpret the production, including Clara Smith, who has appeared in many Essanay productions. Olive Wyndham, Katherine Kaelred, Sydney Booth and Dr. Anna Howard Shaw are other well-known characters who played in the pictures.

The entire plot hinges around Rosalind Fairlie, heiress of the Fairlie fortune, who marries Ben Austin and finds herself staggering under her husband's debts. She has not had time to remove her wedding veil before her husband's creditors swoop down on her and explain that now she is married to Austin, the law can seize her property for his debts. There is also another woman who has been wronged by Austin; she is hounded by him. Many of the factory conditions are shown where women are compelled to work for little pay. The big punch of the production is where on his deathbed Austin appoints his father guardian of his children. The mother, however, finally wins out in the courts after going through many trying experiences.

Her aunt Jane, who has always been an ardent suffragist, wins her to the cause. The lieutenant-governor lends his influence towards the passing of the bill. And of course as a reward is accepted by Rosalind.

NICHOLAS POWER'S SIXTIETH BIRTHDAY

NICHOLAS POWER, head of the Nicholas Power Company, the projector manufacturers, celebrated his sixtieth birthday October 21. Incidentally, the occasion emphasizes Mr. Power's rise to the enviable position he now holds in business and private life alike. Telegrams and congratulatory letters flowed in from all parts of the country last Wednesday, their number fairly astonishing the modest recipient of them.

WASHINGTON HEIGHTS THEATRE DRAWS BIG CROWDS

Within the past few months a number of new theatres have opened in the rapidly growing section of the upper West Side of Manhattan Borough, New York City, known as Washington Heights. Probably one of the handsomest, if not the most pretentious, is the Heights Theatre, six hundred capacity, Messrs. Landau and Bock, proprietors, situated at 181st street and Wadsworth avenue.

The theatre is up to date in every respect. It has upholstered seats, indirect lighting, two motor-driven Standard projection machines, and "Wurlitzer" motion picture orchestra.

The radium gold fibre screen, which is raised a little higher than that in the average theatre, is 13 by 18 feet, and is visible from any seat in the house without the usual craning of necks.

The Heights Theatre was the first in that locality to raise the price of admission to 10 cents for adults at the matinee performance, and 15 cents for adults and 10 cents for children at evening shows.

The house, which is thoroughly fire-proof, with eleven exits, is doing a capacity business, and the slogan, "We do not object to your bringing the children to see the show, but in justice to our patrons we must insist that you keep them quiet," is not a little bit responsible.

A special feature is run daily, and twice a week, Wednesdays and Thursdays, an added feature is shown. On these two days the prices of admission are raised. A special programme is issued to the patrons which shows the entire week's bill, with coming attractions for the following week.

ANOTHER NEW YORK CITY THEATRE OPENS

The Classic Theatre, 181st street and St. Nicholas avenue, New York City, recently opened, is aptly termed the "Theatre Beautiful," as it is in the announcement on the programme issued by the Classic Amusement Company, lessees of the theatre. The house seats six hundred and is up-to-date in every respect.

Two Powers No. 6a motor driven projection machines have been installed. Indirect lighting system is used. The seats are all upholstered, and the roof is made so that it can be opened in

sections during the hot summer nights.

The policy of the house will be "to provide an entertainment of two hours duration, pleasing to the eye, the mind, and the memory, ever mindful of the high moral tone and tastes of its patrons." The manager, A. P. Waxman, is to be congratulated on securing such a creditable accompaniment for the pictures with a symphonic orchestra under the direction of Maestro A. Frankel.

The house opened with "Cabiria" on Thursday, October 1, for a four days run. Arrangements have been made with Paramount and Alco film companies, and together with the showing of features the management also presents Keystone and Ford Sterling mirth provokers. Pathé, Mutual and Universal Weeklies and the Strand war news are also shown, so that every Classic Program includes a feature of from five to seven reels, a comedy and an "Animated Weekly."

The prices of admission are, matinees five and ten cents, evenings ten and fifteen cents.

HERNE'S DOUBLE IN SCREEN PLAY

James A. Herne drew audiences to him, not only as an actor, but because of his fine personal qualities which "got over" in some mysterious way. His personality and magnetism swayed his audiences. For instance, people went to see him in "Shore Acres" and exclaimed not only over his Nat Berry, but over the personal qualities they felt certain Mr. Herne must possess.

Now this lovable side of James A. Herne has been transferred to the screen through the medium of Chas. A. Stevenson, who plays Nat Berry in the Alco release of October 26, the All Star Feature Corporation's production of "Shore Acres."

Screen audiences are noting the strong facial resemblance of Stevenson to Herne and they are endowing him with all the other qualities of James A. Herne.

Great gratification has been expressed by the admirers of Herne that Mr. Stevenson's portrayal of Nat Berry has been put into undying form by the Augustus Thomas producing organization, and Mr. Stevenson's many admirers are delighted, too, that the work of this noted player, which began long before he was a co-star with Kate Claxton in "The Two Orphans," is to have a place in the gallery of the future.



World Film Corporation

Presents a Shubert Photoplay Feature

VIVIAN MARTIN



Released

Nov. 9

IN

The Wishing Ring

By Owen Davis

Arrange Bookings on these features through

WORLD FILM CORPORATION

LEWIS J. SELZNICK, Vice Pres. & Gen'l Mgr.

130 WEST 46TH ST., NEW YORK. 26 Branches Throughout the U. S. & Canada.

LE COURRIER

Cinematographique

28 Boulevard St. Denis, Paris

Directeur: Charles LE FRAPER

Journal hebdomadaire français, le plus important de l'industrie cinématographique.

Envoie numéro spécimen, sur demande. Abonnement 12 FR. 50

Sometimes A Name

is misspelled, or a street number is incorrectly copied from subscription forms. If the wrapper containing your copy of the News each week is incorrectly addressed in any detail, please advise us. It will remove any chance of error or delay in delivery.

MR. EXHIBITOR

Do you know that you can increase your business, IF YOU WILL. Send to the J. H. Genter Co., Inc., Newburgh, N. Y., and get the large free samples of Mirroide the best moving picture screen made. Satisfy yourself that with Mirroide you can get the crowd coming and hold them after you get them. Made in Silver, White, Pale Gold and Silver Flesh. In a rough or matte finish, at 36 1/9 cents a sq. foot.

THE J. H. GENTER CO., Inc. - Newburgh, N. Y.

Do You Want A Piano?

a projection machine, a screen, a ticket chopper, a lobby frame, a lot of new chairs, a box of carbons, a kit of operators' tools, a bottle of machine oil, or any one of a hundred and more other things used in your theatre?

You want the best that money will buy. Personal investigation requires time and discomfort. There is a very simple way to avoid this, and get every possible item of information about anything you want, at the price you want.

Fill in, sign and mail the form below, and give the approximate price you want to pay. Or, if you prefer, write us a short note, outlining in full just what information you want.

In a very short time you will have, at your home or theatre, all available information about the products in which you are interested. Then, at your leisure, you can compare merits and prices, and make your final selection.

There is no obligation nor cost attached. A two cent stamp to mail your inquiry is your only expense.

This is The Buyers' Service Department of The Motion Picture News. It is entirely free.

Fill in this form and mail it. We will send the information you want.

The Buyers' Service Dept.,
The Motion Picture News,
220 W. 42nd St., N. Y. City

Gentlemen: Please send to me immediately, without cost or obligation, complete information concerning

.....
.....
.....

Name

Theatre

Street Address

City State

LIFE PHOTO JOINS ALCO

Life Photo Film Corporation, which in the past has produced such successes as "Northern Lights," "Captain Swift," "The Greyhound" and "The Banker's Daughter," has allied itself with the Alco Film Corporation. Henceforth all Life Photo productions are to be released through Alco. The first release under the new agreement is to be Booth Tarkington's "Springtime," ready in December.

Edward M. Roskam is president of the Life-Photo organization. Leonard Abrahams is vice-president and Bernard Loewenthal, treasurer, while Jesse J. Goldberg is secretary.

The new producing ally of the releasing corporation is only nine months old, but in that short time it has released numerous successes. Recently the Life-Photo Film Corporation bought out the High Grade Feature Film Corporation. The corporation controls the services of William H. Tooker, who was so successful in the leads of their productions.

The Life-Photo offices are at 220 West 42nd street, New York, conveniently adjoining those of Alco, at 218 West 42nd street.

ALLIANCE WARNS TRADE

Editor, MOTION PICTURE NEWS,
New York City.

Dear Sir:—It has come to our attention that a party by the name of H. R. Garson, of Troy, N. Y., has incorporated a company called the Exhibitors All Theatre Film Co., and has issued a prospectus inviting exhibitors to take stock in such company. He offers to give them features for \$15.00 per day, and among the films listed is "The Key to Yesterday."

This company has no connection with the Alliance Film Corporation, which has the sole rights to the Favorite Players production, "The Key to Yesterday," and has no right to offer our pictures to anybody, at the preposterous price of \$15.00, or any other price.

We would thank you to publish this letter in order that exhibitors may not be misled.

Yours very truly,
Alliance Films Corporation,
By ANDREW J. COBE,
General Manager.

800 BOOKINGS FOR "AFTER THE BALL"

The Photo Drama Company reports that Herbert Kelcey and Effie Shannon, in "After the Ball," have over 800 local bookings in Greater New York and New Jersey still to play, and more additional bookings coming in every day. Reports from the out-of-town offices predict unusually large business.

Steiner and Maher and Pierce Kingsley, the producer of the photoplay, are receiving the congratulations of the trade from all quarters.

Music and the Picture

Editor's Note.—This department is prepared to answer all questions from exhibitors relating to the use of music in connection with photoplays, and to suggest suitable music for current pictures. Correspondence will be welcomed

Music for the Picture in Folio Form

By H. S. Fuld

At last! Various music publishers, having arrived at the point where they can see the now insistent demand for suitable music to accompany the pictures, are getting ready to release such music in folio form.

A few of them have had a sort of vague idea as to what was needed, and really tried to get out, and did publish so-called "Music for the Picture."

Since the appearance of the article in this department in the October 17 issue, two such publications have made their appearance and three others are in the printer's hands.

The first one to come to our attention, while not primarily intended for picture accompaniment, nevertheless seems particularly adapted for such use.

There are thirty-five different songs in it, arranged in dance time and practically all of them being popular, the selection of them by titles from the index should enable a pianist to suit them to the pictures.

For instance, take "By the Beautiful Sea." This would make good for any beach or shore scene and played either fast or slow as the action of the picture would demand.

This folio is published by Shapiro, Bernstein & Company of New York. So many pictures of the present day contain somewhere in their make up a ball-room or reception scene where characters are dancing. All the dances, Hesitation, Tango, Fox Trot and so on, are shown in this folio.

In fact, all of the present day dances can be suitably played for by using the music from this folio.

In using such a folio, pick out the song titles best suited, in your opinion, to the scenes and then go at it in this way; taking "Bootles' Baby."

Edison, 2 reels, for example, from the Edison October booklet:

Bootles' Baby

Dramatic. Time, the present. Place, English cavalry barracks.

6-8 allegretto until

Lady standing under tree, Valse lente until

Bootles leaves card table, Gavotte according to action until

Young lady applies for position, Plaintive until

LATEST SHAPIRO SONGS FOR NOVEMBER

1. Tip-Top Tipperary Mary.
2. The Fatherland, The Motherland, The Land of My Best Girl.
3. The War in Snider's Grocery Store.
4. Just 'Round the Corner from Broadway.
5. The Tango in the Sky.
6. Do the Funny Fox-Trot.

Finish of Part I, Swell to FF until
Beginning of Part II, Continue P until

After lady faints, Slow waltz according to action until

Sub-title, "Watching a Race," Galop (short) until

Accident, Plaintive according to action until finish.

In this picture the parting scene between the girl and Bootles is a good place to render "In the Gloaming," "Best for You and Best for Me that We Should Part," and such melodies.

In a box on this page you will find the names of the latest songs for November from the house of Shapiro, Bernstein & Company. This will be a regular feature each week and will contain the names of latest songs.

Popularity of Wurlitzer on the Increase

THE popularity of the one-man orchestra manufactured by the Rudolph Wurlitzer Company, Cincinnati, is evidenced on every hand. Letters are received by the concern from pleased exhibitors in practically every mail. One which expresses unusual appreciation of the merits of the Wurlitzer was written by the enthusiastic president of the Hippodrome Amusement Company, Inc., the owner of the motion picture theatre of that name in the same city.

"Everything in connection with the recent installation of your one-man Wurlitzer orchestra has been so entirely satisfactory in all things promised that I am glad to write you this letter. Use it in any way or refer any exhibitor to me.

"Aside from the saving between one man's and six men's salary—an item of some \$200 per week—no orchestra could possibly so properly accompany our moving pictures as is being done with your instrument.

"My Hippodrome theatre seats 975, and the music there has been quite a problem and an expense to me.

"There is nothing mechanical in the tone of your orchestra. The pipe organ quality especially appeals to my audiences.

"In addition to the hundreds of expressions of delight from my patrons my box office receipts have very much increased in spite of the extremely hot weather we have recently had.

"I am convinced more than ever that the music for motion picture houses must be a one-man orchestra. No body of musicians can possibly change quick enough to follow a film.

"This fortunately figures out a money saver.

"Very truly yours,

"The Hippodrome Amusement Co.,
(Signed) "I. FRANKEL, President."

THE NEW BIG PICTURE DANCE BOOK

THE GEM DANCE FOLIO 1915

Containing 35 Complete Instrumental Pieces for the Pictures—A Great Big Book

SENT POSTPAID FOR 35 CENTS IN STAMPS OR MONEY ORDER

SHAPIRO, BERNSTEIN & CO., 224 W. 47th ST., NEW YORK

ALCO

EVERY WEEK A FEATURE OF A PRETENTIOUS
NATURE FOR THOSE WHO WANT THAT KIND

ALCO

A CORPORATION MARKETING THE PRODUCT OF THE
ALL STAR FEATURE CORPORATION — CALIFORNIA
M. P. CORPORATION — POPULAR PLAYS AND PLAYERS
— B. A. ROLFE PHOTOPLAY CORPORATION

OFFICES OF THE ALCO FILM SERVICE

NEW YORK, 218 West 42d Street.—For State of New York.

CHICAGO, 512 Mellers Bldg., 5 So. Wabash Ave.—For Illinois, Indiana.

SAN FRANCISCO, 234 Eddy Street.—For California, Nevada, Arizona.

BOSTON, 162 Tremont Street.—For Maine, New Hampshire, Vermont, Rhode Island, Massachusetts, Connecticut.

PHILADELPHIA, 1331 Vine Street.—For Southern New Jersey, Eastern Pennsylvania.

PITTSBURGH, 212 Fourth Avenue.—For Western Pennsylvania, Ohio, Kentucky, West Virginia.

BALTIMORE, 327 St. Paul Street.—For Delaware, Maryland, District of Columbia, Virginia.

DENVER—For Colorado, Utah, Wyoming, and New Mexico.

ST. LOUIS, New Grand Central Theatre, Grand and Lucas Avenues.—For Missouri, Kansas, Iowa, Nebraska.

NEW JERSEY, 71 W. 23d Street, New York.—For Northern New Jersey.

MINNEAPOLIS, Temple Court Bldg.—For Wisconsin, Minnesota, North and South Dakota.

LOS ANGELES, 514 West 8th Street.—For California, Nevada, Arizona.

DALLAS, 1902 Commerce Street.—For Texas, Oklahoma, Arkansas.

SEATTLE, 1214 Third Avenue.—For Washington, Idaho, Montana, Oregon.

SPOKANE, 911 Trent Avenue.—For Washington, Idaho, Montana, Oregon.

BUTTE, 27 W. Park Street.—For Washington, Idaho, Montana, Oregon.

PORTLAND, ORE., 710 Northwestern Bank Bldg.—For Washington, Idaho, Montana, Oregon.

COMING — TWO EXCEPTIONALLY FINE PRODUCTIONS
NOV. 9 — THOMAS JEFFERSON IN RIP VAN WINKLE
NOV. 16 — DIGBY BELL IN THE EDUCATION OF MR. PIPP

HUGH HOFFMAN

ALCO

ALCO

AN EXTRAORDINARILY FINE PHOTOPLAY
PRODUCTION OF BRET HARTE'S LITERARY
GEM, TAKEN AT THE ORIGINAL LOCATIONS

SALOMY JANE

PRODUCED
BY THE
CALIFORNIA
M. P. CORP'N
By Arrangement with
The Liebler Co.



A MASTERPIECE OF CHARACTERIZA-
TION OF VIRILE WESTERN TYPES AS
BRET HARTE KNEW THEM - WITH
BEATRIZ MICHELENA AS "SALOMY"

ALCO FILM CORPORATION
HOME OFFICE, ALCO BUILDING, 218 WEST 42nd ST., NEW YORK

ALCO

WATCH ALCO GROW

ALCO FILM CORPORATION and LIFE-PHOTO FILM CORPORATION

join with gratification in an announcement that henceforth

All Life Photo Productions Will Be Released By Alco

Alco is gratified at being able to make this announcement since it means the addition to the Alco program of the productions of the corporation which gave to the public "Captain Swift," "Northern Lights," "The Greyhound," and "The Banker's Daughter."

Life-Photo is gratified because it has investigated the whole field of means of release and has found Alco first and best.

Life-Photo's initial release through Alco will be "SPRINGTIME"

by Booth Tarkington.

Name of star to be announced later

Ready for distribution in December

Alco Film Corporation
218 West 42nd Street
New York

Life-Photo Film Corporation
220 West 42nd Street
New York

Branches in all principal cities Studios and Laboratory, Grantwood, N. J.

WATCH ALCO GROW

STATE RIGHTS

MARIE DRESSLER

America's Greatest Box Office Attraction

IN

A SIX REEL COMEDY

TILLIE'S PUNCTURED ROMANCE

SUPPORTED BY

AUTHOR & DIRECTOR



MARIE DRESSLER



CHAS. CHAPLIN



MABEL NORMAND



MACK SENNETT

THE "IMPOSSIBLE" ATTAINED—A SIX REEL COMEDY

Without a doubt the greatest money drawing photoplay ever made. Stands absolutely alone. No picture on earth can compete with it. A great story with a thousand laughs.

WILL DEMAND BIG TIME BOOKING

STATE RIGHT BUYERS—This production is now ready to be shown you. We don't want to sell you "a cat in a bag." You must come to New York and see the picture—and then make arrangements for territory.

A FULL LINE OF ADVERTISING

WRITE OR WIRE FOR TERRITORIAL RESERVATION

KEYSTONE FILM COMPANY

LONGACRE BLDG., 42nd St. and B'way.

Telephone
BRYANT 6784

NEW YORK

WE'RE OFF WITH

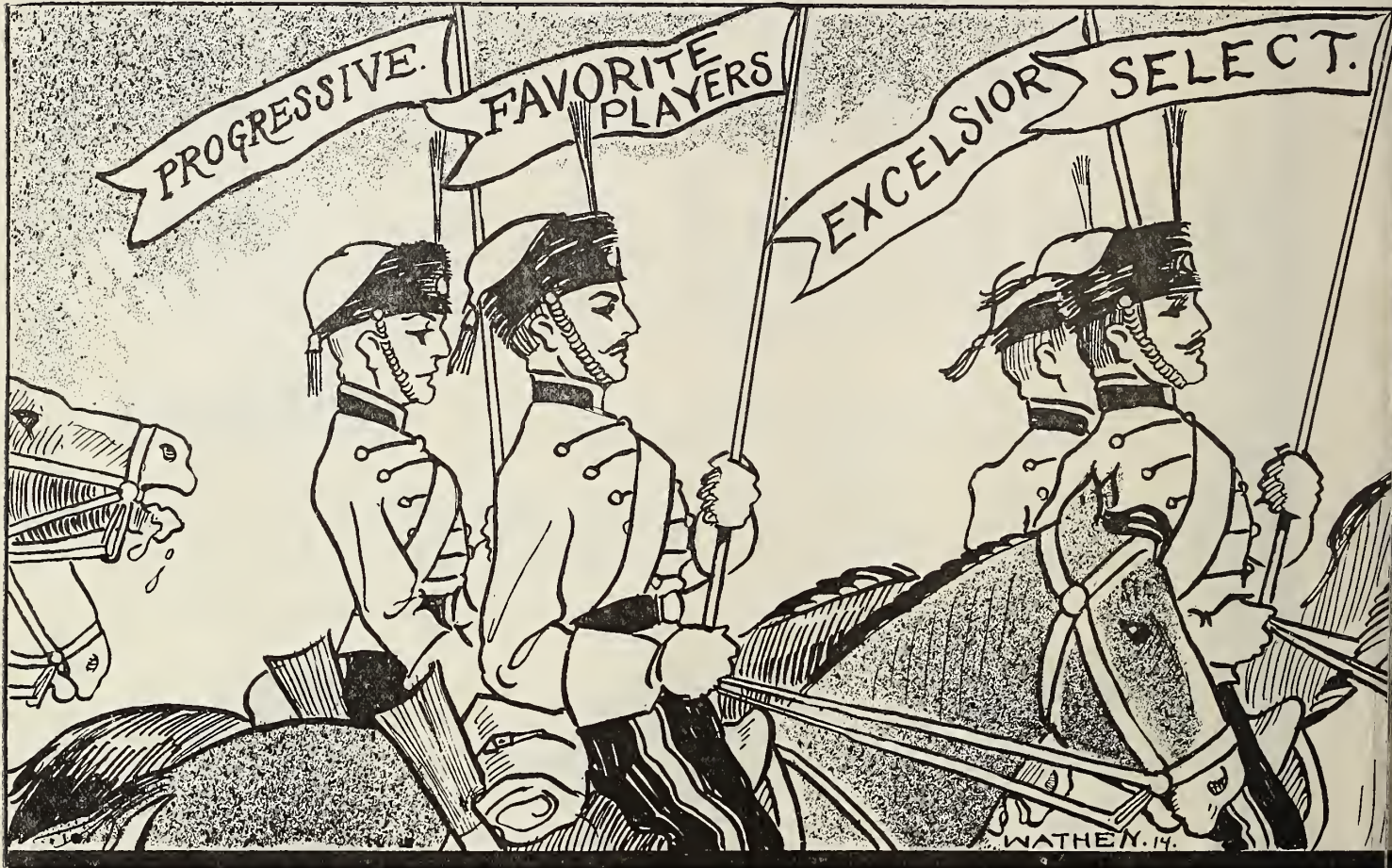

Releases

"THE KEY TO YESTERDAY"

Released Oct. 12 by Favorite Players Film Co., from book by Charles Neville Buck, with CARLYLE BLACKWELL, in the leading role.

"THE PATH FORBIDDEN"

Released Oct. 19 by Excelsior Feature Film Co., from book by John B. Hymer, with OCTAVIA HANDWORTH, GORDON DE MAINE AND WILLIAM A. WILLIAMS in the leading roles.

"AT THE OLD CROSS ROADS"

Released Oct. 26 by Select Photoplay Producing Co. Arthur C. Aiston's famous play, with ESTHA WILLIAMS, the original star, in the leading role.

"McVEAGH OF THE SOUTH SEAS"

Released Nov. 2 by Progressive Motion Picture Co. A story of daring and action, featuring HARRY CAREY.

"THE HOOSIER SCHOOLMASTER"

Released Nov. 9 by Masterpiece Film Mfg. Co. Featuring MAX FIGMAN, supported by Lolita Robertson, in Edward Eggleston's immortal story.

"THE MAN WHO COULD NOT LOSE"

Released Nov. 16 by Favorite Players Film Co. From book by Richard Harding Davis, featuring CARLYLE BLACKWELL.

"WHEN FATE LEADS TRUMP"

Released Nov. 23 by Excelsior Feature Film Co. From book by John B. Hymer, with OCTAVIA HANDWORTH, GORDON DE MAINE AND WILLIAM A. WILLIAMS in the leading roles.

ALLIANCE FILMS CORPORATION

FLYING COLORS!



Exchanges

ALLIANCE FILM SERVICE, 115 Fourth Ave., Pittsburg, Pa. A. A. Weiland, Mgr. Ohio, Western Pennsylvania and W. Virginia.

ALL THEATRES FILM CO., 18 Chapin Block, Buffalo, N. Y. S. S. Webster, Mgr. Times Bldg., Troy, Jno. F. Heffron, Mgr., Troy. New York State.

ALLIANCE FILM SERVICE, 128 W. 46th St., N. Y. City. N. Y. City, Connecticut, Massachusetts, Vermont, New Hampshire, Maine. M. F. Tobias, Mgr.

ALLIANCE FEATURE FILM SERVICE, controlled by Mecca Feature Film Co., 130 W. 46th St., N. Y. City. Northern New Jersey.

ELECTRIC THEATRE SUPPLY CO., Vine and 13th Sts., Philadelphia, Pa. S. New Jersey, E. Pennsylvania, Maryland, Delaware, Dist. Col.

APEX FEATURE SERVICE, 417 Rhodes Bldg., Atlanta, Ga. O. P. Hall, Mgr. Virginia, N. Carolina, S. Carolina, Georgia, Florida, Alabama, Mississippi, and Louisiana.

APEX FEATURE SERVICE, 510 McCall Bldg., Memphis, Tenn. M. Simmonds, Mgr. Tennessee.

APEX FEATURE SERVICE, 311 Andrews Bldg., Dallas, Tex. M. Levison, Mgr. Texas, Arkansas and Oklahoma.

CASINO FEATURE FILM CO., Dime Savings Bank Bldg., Detroit, Mich. Michigan.

CELEBRATED PLAYERS FILM CO., 64 W. Randolph St., Chicago. Illinois.

NAT A. MAGNER CO., Pacific Bldg., San Francisco, Cal. California, Nevada and Arizona.

CO-OPERATIVE SERVICE CO., Indianapolis, Ind. E. H. Brient, Mgr. Indiana and Kentucky.

126 West 46th Street, NEW YORK CITY

ALLIANCE PROGRAM

ALLIANCE PROGRAM

THE HOOSIER SCHOOLMASTER
 EDWARD EGGLESTON'S
 IMMORTAL BOOK
 IN FIVE REELS, WITH
MR. MAX FIGMAN

SUPPORTED BY -
MISS LOLITA ROBERTSON
 A GREAT AMERICAN
 CLASSIC, INTERPRETED
 BY NATIONAL STARS
 RELEASED NOV. 9TH
 IN THE
ALLIANCE
 PROGRAM

Masterpiece Film 1111 Van Nuys Bldg
Manufacturing Co. Los Angeles, Cal

W

The Great Secret Service Serial

In 20 Weekly Installments of 3 Reels Each

Each Episode Conclusive in itself and supported by the Greatest Publicity Campaign Ever Attempted.

**Chief of the U. S. Secret Service
William J. Flynn**

has written this great romance of his personal experiences in the Secret Service with the object of not only entertaining, but with the view of demonstrating that:

"HONESTY IS THE BEST POLICY"

and through the great medium of the Motion Picture, inspire a respect for:
LAW AND ORDER and assist in the **PREVENTION OF CRIME.**

Not a sermon, but a thrilling recital of Chief Flynn's 20 most famous cases, depicting the adventures of two Secret Service operatives (a Lovable Heroine and a Manly Hero). Filmed in a manner to satisfy the most exacting demand for action and exciting incidents, and exposing the traps set for the law abiding citizen by the pirates on society.

**EXHIBITORS APPLY FOR EXCLUSIVE BOOKINGS NOW
RESPONSIBLE AND AGGRESSIVE EXCHANGES ASK FOR
OUR TERRITORIAL PROPOSITION**

**FILM ATTRACTIONS CO., Inc.
1482 Broadway, N. Y. City**

Produced under the personal supervision of C. V. Henkel, Prest. and General Manager.

KRITERION PROGRAM

will be distributed from the following cities:

New York, Boston, Philadelphia, Baltimore, Pittsburgh, Cleveland, Cincinnati, Indianapolis, Chicago, Minneapolis, St. Louis, Kansas City, Atlanta, Dallas, Denver, Seattle, San Francisco, Los Angeles, Winnipeg, Montreal.

MONDAY	TUESDAY	WEDNESDAY	THURSDAY	FRIDAY	SATURDAY
Comedy Special	Comedy Special	Comedy Special	Comedy Special	Comedy Special	Comedy Special

SUNDAY

Special——Well Known——Star

"Made in America Photoplays" - - KRITERION PROGRAM
OUR GOODS ARE NOT UNKNOWN—the biggest and best theatres are now using them.

Directors, Stars and class of production are standard.

RELEASE DATE IS AT YOUR DOOR, MR. EXHIBITOR

WATCH OUR REVIEWS on our subject to the trade.

Get the habit now - KRITERION KRITERION

"YOU will not make any mistake by so seeking this service."

"Brands, Subjects, Productions, Display carefully assembled."

MICA FILM CORPORATION

220 West 42nd Street (Temporary Headquarters) New York City

MOTIOGRAPH RESULTS

SPOKEN OF IN ALL COUNTRIES

The Enterprise Optical Mfg. Co.,
Chicago, Ills.

New So. Wales, Australia.

Gentlemen: In reference to the MOTIOGRAPH machine, I bought two of these machines in 1911 and 1912, and both of them are in perfect running order at the present day, and each doing work seven nights per week. During their life neither machine has stopped for one single night.

I consider the MOTIOGRAPH excels all other machines for projection, steadiness, and costs less. No wonder you say, "Cut down your repair bills and get a MOTIOGRAPH."

Have had experience with several other machines, and I would have none other than a MOTIOGRAPH.

Yours sincerely,

(Signed) BERT E. AUBUSSON, Mgr.,

Globe Pictures, Southern Circuit, New South Wales, Australia.

ALL MOTIOGRAPH USERS GET THE SAME SATISFACTION

Get in line with your next order, and try MOTIOGRAPH SATISFACTION

THE ENTERPRISE OPTICAL MFG. CO., 568 W. Randolph Street, CHICAGO

Eastern Office: 21 E. 14th Street, New York

Western Office: 833 Market Street, San Francisco

Don't Be Afraid

Use Posters on Billboards as Well as in Front of Your Lobby

There are a lot of people in your town who never pass your theatre. How are you going to reach them? **One excellent way is to use posters on boards where these people will see them. Put up a few twenty-four sheets and watch the result.** Legitimate theatres use them and so do some moving picture proprietors. Are you one of them?

Here is a man in Maine and not in a very large city either—see what he did. Take it from him, it pays for he is still doing it.

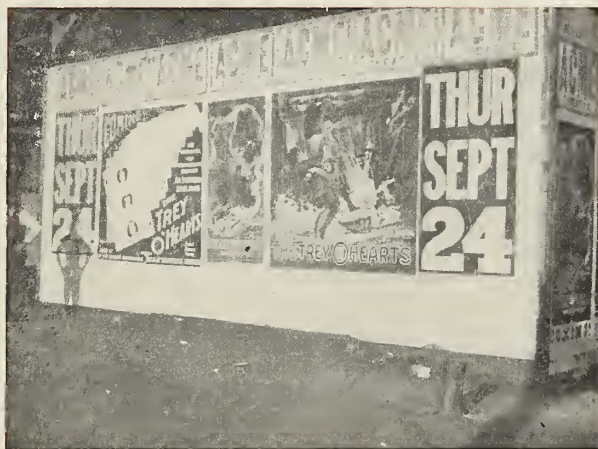

All Universal pictures are thoroughly covered by the best posters on the market, in all sizes. Here are a few of the features of the posters made by the MORGAN LITHOGRAPH COMPANY.

3-Sheets for 1-Reel Subjects

Portrait Posters of Universal Stars

A Six-color 1-Sheet War Map

Extraordinary quality in all one, three, six, eight and twenty-four sheets

Write to-day to the

MORGAN LITHOGRAPH CO., Cleveland, Ohio

OR THE

Service Department

UNIVERSAL FILM MANUFACTURING COMPANY

1600 Broadway

Carl Laemmle, Pres.

New York City



*A Country Mouse
A Farmer's Wife*



*A Country Mouse
A Senator's Wife*

Adele Farrington *in* The Country Mouse

A rippling comedy, replete with stirring social and political scenes. A film portraying graphic phases of everyday American life, from Farm to Senate

A typical drama of Love, Politics and the Home—the making of a Statesman—the awakening of a Woman.

A motion picture of highest quality, appealing to the great American public.



BOSWORTH
INC.
LOS ANGELES



Released November 23rd through the Paramount Program.



NOVEMBER 14, 1914

Motion Picture News

HAS THE QUALITY CIRCULATION OF THE TRADE

PARAMOUNT PICTURES

JESSE L. LASKY

PRESENTS

THE SCREENS MOST SUCCESSFUL LEGITIMATE STAR

EDWARD ABELES

IN

JAMES MONTGOMERY'S
INTERNATIONAL DRAMATIC SUCCESS

**READY
MONEY**

A MYRIAD THRILLS NOW PLAYING

JESSE L. LASKY FEATURE PLAY CO.

LONG ACRE THEATRE W. 48TH STREET N.Y.C.

JESSE L. LASKY PRESIDENT SAMUEL GOLDFISH TREAS. & GEN'L. MANAGER CECIL B. DEMILLE DIRECTOR GENERAL





THE TREY O HEARTS

BY LOUIS JOSEPH VANCE

THE MASTER PROBLEM PLAY
IN FIFTEEN STORIES

FEATURING
CLEO MADISON & GEO LARKIN
WILFRED LUCAS

WINNIE BOSCH
STORY FIFTEEN



PARAMOUNT

PICTURES

DANIEL FROHMAN
Presents

The powerful drama
By
CLYDE FITCH



“**THE STRAIGHT ROAD**”
with
GLADYS HANSON
In Four Parts of Motion Pictures.

Clyde Fitch's great human
drama of a submerged
soul's conflict and triumph.

Released Nov. 12th.

Produced by the

FAMOUS PLAYERS FILM CO

ADOLPH ZUKOR, President,

DANIEL FROHMAN, Managing Director **EDWIN S. PORTER**, Technical Director

Executive Offices,

213-229 W. 26TH STREET, NEW YORK.

36
FAMOUS
FEATURES
A YEAR

36
FAMOUS
FEATURES
A YEAR

YOU ARE SURE TO WIN WITH THIS HAND

THE WEEK OF NOVEMBER 8th



Released Exclusively Through the Mutual Film Corporation

PHOTOS—8 by 10 photos of the following players can be had by sending to the PUBLICITY DEPT. 15 cents for one, 50 cents for set of four, one dollar for set of eight, etc.

Mabel Normand	Charles Ray	Elizabeth Burbridge	Sid Chaplin
Barney Sherry	Roy Laidlaw	Mack Sennett	Roscoe Arbuckle
Thos. H. Ince	C. N. Mortenson	Walter Belasco	Shorty Hamilton
Enid Markey	Charles Chaplin	John Keller	W. S. Hart
Richard Stanton	Margaret Thompson	Jay Hunt	Walter Edwards
Leona Hutton	Frank Borzage	Jerome Storm	Gertrude Claire
Rhea Mitchell	Harry Keenan	Webster Campbell	J. Frank Burke
			Herschel Mayall

KEYSTONE MABEL IN TEN NEW STYLES—15 cents for one, 50 cents for set of four, etc.

PENNANTS—Beautiful colored pennants of our four brands, KAY BEE, KEYSTONE, BRONCHO and DOMINO. 25 cents for one, one dollar for set of four.

New York Motion Picture Corporation

Longacre Building, 42nd St. and Broadway

NEW YORK

AD KESSEL, Jr., President

DON'T TURN THE PAGE!

Get Busy and Book These Tremendous Features
Through the Nearest Exchange Offered by the

KINETOPHOTE and K. C. Booking Co., Inc.

“MARKIA or THE DESTRUCTION OF CARTHAGE,” the \$200,000
Ambrosio masterpiece in Five Parts

“THE SPIRIT OF THE POPPY”

By **CATHERINE CARR**

The Greatest Moral Photoplay ever written. A 6-part Kinetophote Production. Technically, the best thing ever done on the screen, with an all-star cast including EDWARD MACKAY

“THE SPAN OF LIFE” Sutton Vane's old Melodrama
with a bigger punch than ever
the stage production had.

with **LIONEL BARRYMORE** and Gladys Wynne

(FIVE PARTS) A KINETOPHOTE MARVEL

“THE COMING POWER” A powerful story of
Political Intrigue
and Retribution.
With such Broad-

way Stars as **LIONEL ADAMS, EDITH LUCKETT, ANNA ROSE** and **WILLIAM CRIMMINS.**
(FOUR PARTS) IN KINETOPHOTE STYLE

“BORN AGAIN” One of the Wonder Pictures of this year. A
sensation that tells a gripping story.

With **BEULAH POYNTER**, the famed theatrical Star

FOR YOUR CONVENIENCE! FOR QUICK SERVICE!

The Kinetophote offers through the K. C. Booking Co., Inc.

THESE WELL ESTABLISHED EXCHANGES.

AMERICAN FEATURE FILM CO., 162 Tremont Street, Boston, Mass., Maine, New Hampshire, Vermont, Massachusetts, Rhode Island and Connecticut—All New England.

EASTERN BOOKING OFFICES, 1237 Vine Street, Philadelphia, Eastern Pennsylvania, Southern New Jersey, Virginia, Delaware and District of Columbia.

EASTERN BOOKING OFFICES (Pittsburgh Branch), 432 Wash Building, Western Pennsylvania and West Virginia.

EASTERN BOOKING OFFICES (Cleveland Branch), 218 Columbia Bldg., State of Ohio.

K. C. BOOKING CO., INC. (Chicago Branch, address announced later), Illinois and Wisconsin.

ATLANTIC SERVICE CO., 508 Rhodes Bldg., Atlanta, Ga., Georgia, Alabama, North Carolina, South Carolina, Mississippi and Florida.

CALIFORNIA FILM SERVICE CORPORATION, 1149 Mission St., San Francisco, Cal. (With Branches in Salt Lake City, Denver, Seattle, Portland, Ore., and Los Angeles, 403 Marsh Strong Bldg.), California, Oregon, Washington, New Mexico, Montana, Idaho, Wyoming, Colorado, Nevada, Arizona and Utah.

DALLAS FILM CO., Dallas, Texas. Texas, Louisiana, Oklahoma and Arkansas.

Additional List of Exchanges to be Announced in the Next Issue.

All Distributing the Exclusive Program of the

Feature



Productions

Ira H. Simmons, Gen. Mgr.

Telephone: 6072 Bryant 126-132 West 46th Street, NEW YORK CITY

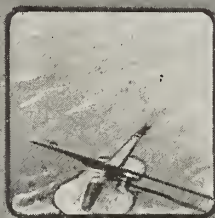

The LAST CHORD

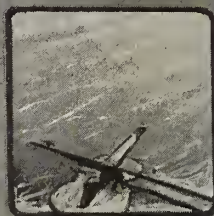

THE LAST CHORD

The haunting harmonies of *the Sonata of Valkierie* bring both romance and tragedy into a woman's life. Three parts of intense dramatic action.

UNITED FILM SERVICE (WARNER'S FEATURES, INC.) N.Y.

**UNITED
UNITED
FILM
SERVICE**

COMEDIES—Features—Specials—Every reel of the high standard established by our famous feature releases. There are 42 Warner's Exchanges. Write the one nearest you.

Atlanta, Ga.
Baltimore, Md.
Boston, Mass.
Buffalo, N. Y.
Calgary, Can.
Cleveland, Ohio
Charlotte, N. C.
Chicago, Ill.
Charleston, W. Va.
Cincinnati, Ohio

Dallas, Texas
Denver, Colo.
Des Moines, Iowa
Detroit, Mich.
Edmonton, Can.
El Paso, Texas
Indianapolis, Ind.
Kansas City, Mo.
Los Angeles, Cal.
Louisville, Ky.

Minneapolis, Minn.
Montreal, Can.
Nashville, Tenn.
Newark, N. J.
New Orleans, La.
New York City
Omaha, Neb.
Philadelphia, Pa.
Pittsburgh, Pa.
Portland, Me.

Portland, Ore.
San Antonio, Texas
San Francisco, Cal.
St. Louis, Mo.
Seattle, Wash.
Spokane, Wash.
Syracuse, N. Y.
Toronto, Can.
Washington, D. C.
Wilkes Barre, Pa.
Winnipeg, Can.

Main European Office: 99 Charing Cross Road, London, W. C.

WARNER'S FEATURES, Inc.

New York

ALLIANCE PROGRAM

THE HOOSIER SCHOOLMASTER
 EDWARD EGGLESTON'S
 IMMORTAL BOOK
 IN FIVE REELS, WITH
MR. MAX FIGMAN

SUPPORTED BY -
MISS LOLITA ROBERTSON
 A GREAT AMERICAN
 CLASSIC, INTERPRETED
 BY NATIONAL STARS
 RELEASED NOV. 9TH
 IN THE
ALLIANCE PROGRAM

**Masterpiece Film 1111 Van Nuys Bldg
 Manufacturing Co. Los Angeles, Cal**

The Program of Real Features

EXCHANGES

ALLIANCE FILM SERVICE, 115 Fourth Ave., Pittsburgh, Pa. A. A. Weiland, Mgr. Ohio, Western Pennsylvania and West Virginia.

ALL THEATRES FILM CO., 18 Chapin Block, Buffalo, N. Y. S. S. Webster, Mgr. Times Bldg., Troy, Jno. F. Heffron, Mgr., Troy. New York State.

ALLIANCE FILM SERVICE, 128 W. 46th St., New York City. M. F. Tobias, Mgr. New York City.

ALLIANCE FILM SERVICE, controlled by Eastern Feature Film Co., Inc., 57 Church St., Boston, Mass. New England.

ALLIANCE FEATURE FILM SERVICE, controlled by Mecca Feature Film Co., 130 W. 46th St., New York City. Northern New Jersey.

ELECTRIC THEATRE SUPPLY CO., Vine and 13th Sts., Philadelphia, Pa. Southern New Jersey, Eastern Pennsylvania, Maryland, Delaware, District of Columbia.

APEX FEATURE SERVICE, 417 Rhodes Bldg., Atlanta, Ga. O. P. Hall, Mgr. Virginia, North Carolina, South Carolina, Georgia, Florida, Alabama, Mississippi and Louisiana.

APEX FEATURE SERVICE, 510 McCall Bldg., Memphis, Tenn. M. Simmonds, Mgr. Tennessee.

APEX FEATURE SERVICE, 311 Andrews Bldg., Dallas, Texas. M. Levinson, Mgr. Texas, Arkansas and Oklahoma.

CASINO FEATURE FILM CO., Dime Savings Bank Bldg., Detroit, Mich. Michigan.

CELEBRATED PLAYERS FILM CO., 64 W. Randolph St., Chicago. Illinois.

NAT. A. MAGNER CO., 218 Superba Theater Bldg., 520 Broadway, Los Angeles, Cal. California, Nevada and Arizona.

RELEASES

"The Key to Yesterday"

Released October 12 by Favorite Players Film Company, from book by Charles Neville Buck, with CARLYLE BLACKWELL, in the Leading Role.

"The Path Forbidden"

Released October 19 by Excelsior Feature Film Company, from book by John B. Hymer, with OCTAVIA HANDWORTH, GORDON DeMAINE and WILLIAM A. WILLIAMS in the Leading Roles.

"At the Old Cross Roads"

Released October 26 by Select Photoplay Producing Company. Arthur C. Aiston's famous play, with ESTHA WILLIAMS, The Original Star, in the Leading Role.

"McVeagh of the South Seas"

Released November 2 by Progressive Motion Picture Company. A story of daring and action, featuring HARRY CAREY.

"The Hoosier Schoolmaster"

Released November 9 by Masterpiece Film Manufacturing Company. Featuring MAX FIGMAN.

"The Man Who Could Not Lose"

Released November 16 by Favorite Players Film Company. From book by Richard Harding Davis, featuring CARLYLE BLACKWELL.

"When Fate Leads Trump"

Released November 23 by Excelsior Feature Film Company. From book by Alice M. Roberts, with OCTAVIA HANDWORTH, GORDON DeMAINE and WILLIAM A. WILLIAMS in the Leading Roles.

ALLIANCE FILMS CORPORATION

126 W. 46th Street

New York City



THE BRAINS OF TWO BIG ENTERPRISES HAVE COMBINED



LEWIS J. SELZNICK

HAS ARRANGED TO HAVE THE

World Film Corporation

carry out the idea that originated with **MRS. MEDILL McCORMICK**, of Chicago, the executive head of the Woman's Suffrage Association, to extend the cause of woman's suffrage by means of the sensational melodramatic feature.



MRS. MEDILL McCORMICK



LEWIS J. SELZNICK

"Your Girl and Mine"

In 7 Reels, with Dr. Anna Howard Shaw and such noted Broadway players as Olive Wyndham, Katherine Kaelred and Sidney Booth. Read James S. McQuade's Review of "Your Girl and Mine" in the Last Issue of the Moving Picture World

400,000 Women, Members of the Suffrage Organization, Are Selling Tickets Now
Your Audience Is Ready.

Be the First to Take Advantage of This Tremendous Selling Force and Publicity

Phone or Wire Our Nearest Branch Office for Further Details

WORLD FILM CORPORATION

LEWIS J. SELZNICK, Vice-President and General Manager

130 West 46th Street

New York City

26 Branches Throughout the United States and Canada, with 12 More to be Opened Within a Month





The One
Feature Production
That Stands
As The Greatest
Achievement in
The Motion Picture
Industry!

THE MILLION DOLLAR MYSTERY

Story by Harold MacGrath
Scenario by Lloyd Lonergan

Thanhouser's Million Dollar
Motion Picture Production

21 episodes have
been released. For
booking arrangements apply
to Syndicate representative at any
Mutual Exchange in America.

Syndicate Film Corporation

71 West 23rd Street, New York
Room 411, 5 S. Wabash Avenue, Chicago

Thanhouser
Productions
Are Known
Everywhere—

—for greatest stars
—for finest scenery
—for exceptional photography

Regular Than-
houser releases are
distributed exclusively in
the United States and Canada by
The Mutual Film Corporation. Any
Mutual Exchange can supply the fol-
lowing releases.

The Thanhouser Three-A-Week

Tuesday, Nov. 10th. "The Terror of Anger"—a two reel drama with a remarkable moral. Very cleverly portrayed by Mignon Anderson, Morris Foster and Joseph Philips.

Friday, Nov. 13th. "The Chasm"—a beautiful drama played by an exceptional cast, including Dave Thompson, Marguerite Loveridge, James Durkin, Morgan Jones and W. Sherwood.

Sunday, Nov. 15th. "The Man with the Hoe"—an interesting heart story based on the famous painting—"The Man with the Hoe." The cast includes Marguerite Loveridge, Frank Wood, Virginia Waite and Dave Thompson.

**Thanhouser Film
Corporation**

New Rochelle, N. Y.

Head European Office, Thanhouser Films, Ltd.
London, W. C., England



????????????

One Thousand Dollars in Gold
FOR ANSWERS TO
12 Vital Questions of Life
TELL US WHO PAYS AND GET

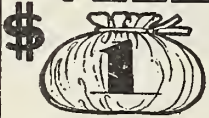

A series of twelve crowd-drawing, money-getting features to be released monthly in numerical order, each separate and distinct in title, plot and treatment—each propounding a vital question of life—each portraying a compelling dramatic story—have been selected for production by the Balboa Amusement Producing Co., of Long Beach, California.

This group of one dozen masterful photo-plays—two of which have been completed—possess all the charm and fascination of the greatest serials of the year with a tremendous added advantage—the advantage that must be derived from a strong appeal to the minds of millions. A prize of ONE THOUSAND DOLLARS IN GOLD—which will be given by the Balboa Company without restriction or reservation for the most satisfactory answers to these questions—will arouse the interest of all the masses and all the classes and cause the box office receipts of exhibitors everywhere to forge ahead of all past records.

Twelve dramas pulsating with human interest involving the twelve most perplexing domestic problems of the hour—twelve dramas that will arouse widespread discussion and cause endless comment—will soon be available for booking in all sections of the United States through a prominent chain of reliable exchanges.

Watch for them. Ask for them. Demand them. Full information furnished upon request. For information wire or write the

BALBOA AMUSEMENT PRODUCING CO.

H. M. Horkheimer,
 President and General Manager

E. D. Horkheimer,
 Secretary and Treasurer

"Makers of The Pictures Beautiful"

LONG BEACH, CALIFORNIA

BALBOA

Stands for Motion Picture Perfection

MORE than two hundred dramatic features and a score of comedies made by the Balboa Amusement Producing Company of Long Beach, California, have been sold to leading exchange organizations in the United States during the past year. Among these notable photo-plays—all of which have won the unqualified approval of exhibitors and the hearty admiration of the public everywhere—is the stupendous Balboa version of—

ST. ELMO

In Six Reels

THIS acknowledged masterpiece—now controlled by the Box Office Attraction Company, of New York—will show earnings in excess of \$250,000 before its money-getting possibilities have been exhausted. At the New York Strand Theatre, the largest and finest motion picture house in the world, St. Elmo broke all box office records during the week of its engagement and immediately thereafter repeated the performance at nine other New York theaters. The two, three and four-reel Balboa dramas are proportionately magnetic, the photography is above criticism, the scenes brilliant and beautiful, and the acting superb. The plays and the stories back of them are absorbingly interesting—thrilling—gripping—and never fail to hold the spell-bound attention of the audience. In all of those essentials that entitle motion pictures to a high place among the various forms of public amusement, Balboa Feature Films are supreme.

This Big List Is But a Part of the Balboa Company's Productions

MADE FOR PATHE FRERES Released by The General Film Company

A Rash Revenge, 1 Reel Comedy.
All on Account of Polly, 1 Reel Comedy.
Won by a Nose, 1 Reel Comedy.
The Moth and the Flame, 2 Reel Drama.
The Power of Print, 2 Reel Drama.
You've Got to Pay, 1 Reel Drama.
By Impulse, 1 Reel Drama.
A Midnight Call, 1 Reel Drama.
Ahide with Me, 1 Reel Drama.

MADE FOR PATHE FRERES Released by Electric Film Company

When Fate Was Kind, 3 Reel Drama.

MADE FOR THE KALEM COMPANY Released by the General Film Company

A Race for the Mine, 1 Reel Drama.
The Intrigue, 2 Reel Drama.
The Rejuvenator, 1 Reel Comedy.

MADE FOR WARNER Released by the Warner Feature Film Co.

The Path of Sorrow, 3 Reel Drama.

MADE FOR THE UNIVERSITY Released by the University Film Co.

The Counterfeit, 2 Reel Drama.
Thou Shalt Not Steal, 2 Reel Drama.

MADE FOR WILLIAM FOX Released by the Box Office Attraction Co.

St. Elmo, 6 Reel Balboa Drama.
Will o' the Wisp, 4 Reel Balboa Drama.
Sands of Life, 2 Reel Balboa Drama.
Nerve, 1 Reel Balboa Drama.
The Silver Lining, 3 Reel Balboa Drama.

The Imprint, 1 Reel White Star Drama.

The Way of the World, 1 Reel Nemo Drama.

Sacrificial Fires, 3 Reel Balboa Drama.

Gypsy Love, 3 Reel Balboa Drama.

Cruise of the Hell-Ship, 3 Reel Balboa Drama.

When the Troupe Closed, 1 Reel Joy Comedy.

The Unexpected, 3 Reel Balboa Drama.

The Rat, 2 Reel Balboa Drama.

It Will All Come Out in the Wash, 1 Reel Joy Comedy.

Hunchback of Cedar Lodge, 3 Reel Balboa Drama.

The Call of the Heart, 2 Reel Balboa Drama.

The Human Soul, 3 Reel Balboa Drama.

Hush, 1 Reel Joy Comedy.

End of the Bridge, 3 Reel Balboa Drama.

Bitter Sweets, 3 Reel Nemo Drama.

Through Fire and Water, 2 Reel Nemo Drama.

The Break-Up, 2 Reel Nemo Drama.

Message of the Mind, 3 Reel Balboa Drama.

Nobody Loves a Fat Man, 1 Reel Joy Comedy.

The Square Triangle, 3 Reel Balboa Drama.

Eggs and Water, 1 Reel Joy Comedy.

The Boob and the Bandit, 1 Reel Joy Comedy.

A Bear Escape, 1 Reel Joy Comedy.

Seeds of Jealousy, 3 Reel Nemo Drama.

Heart of the Brute, 2 Reel Balboa Drama.

Guns and Garlic, 1 Reel Joy Comedy.

Oh You Circus Day, 1 Reel Joy Comedy.

Bumping the Bumps, 1 Reel Joy Comedy.

Vengeance of the Flames, 3 Reel White Star Drama.

The Smith-Jones Affair, 1 Reel Joy Comedy.

Sorefoot's Racer, 1 Reel Joy Comedy.

To Love and to Hold, 2 Reel White Star Drama.

The Chief's Day Off, 1 Reel Joy Comedy.

Almost Crazy, 1 Reel Joy Drama.

The Winner, 3 Reel Nemo Drama.

Thru Night to Light, 3 Reel Nemo Drama.

A Great Secret, 3 Reel White Star Drama.

The Vow, 3 Reel Nemo Drama.

The Mask, 2 Reel White Star Drama.

The Awakening, 3 Reel White Star Comedy Drama.

Little Sunbeam, 3 Reel Balboa Drama.

Storms of Life, 3 Reel White Star Drama.

Little Jack, 3 Reel Balboa Drama.

The Judge's Wife, 3 Reel White Star Drama.

Dream of Loco Juan, 2 Reel Balboa Drama.

The Braeclet, 3 Reel White Star Drama.

The Criminal Code, 4 Reel Balboa Drama.

The Test of Manhood, 3 Reel Balboa Drama.

It Happened One Night, 1 Reel Joy Comedy.

A Prize in Every Package, 1 Reel Joy Comedy.

Prof. Bugs, 1 Reel Joy Comedy.

BALBOA AMUSEMENT PRODUCING CO.

H. M. Horkheimer,
President and General Manager

E. D. Horkheimer,
Secretary and Treasurer

"Makers of The Pictures Beautiful"

LONG BEACH, CALIFORNIA

SPECIAL FEATURES

General Film Company

TITLE	MAKE	No. of Reels	TITLE	MAKE	No. of Reels
THIRD DEGREE	Lubin	5	MAN'S ENEMY	K. & E. Biograph	3
THOR, LORD OF JUNGLE	Selig	3	IN TUNE WITH THE WILD	Selig	3
THE BATTLE OF SHILOH	Lubin	4	THE WOLF	Lubin	6
THE LION AND THE MOUSE	Lubin	6	SHADOWS OF THE PAST	Vitagraph	3
THROUGH FIRE TO FORTUNE	Lubin	5	MR. BINGLES' MELODRAMA	Vitagraph	3
JUDITH OF BETHULIA	Biograph	4	MEN AND WOMEN	K. & E. Biograph	3
GERMINAL	Pathe	5	THE SECRET OF THE RING	Kleine	3
LOST IN MID OCEAN	Vitagraph	3	MY FRIEND FROM INDIA	Edison	3
A ROMANY SPY	Pathe	3	LIBERTY BELLES	K. & E. Biograph	3
A CELEBRATED CASE	Kalem	4	THE ERRING	Lubin	3
THE FULFILLMENT	Essanay	3	AMBUSHED	Essanay	3
NIGHT RIDERS OF PETERSHAM	Vitagraph	3	SONG OF THE SOUL	Kleine	3
HARDING'S HERITAGE	Pathe	3	KIT, THE ARKANSAS TRAVELER	Kalem	3
DAUGHTERS OF MEN	Lubin	5	CHIP OF THE FLYING "U"	Selig	3
THE OTHER HALF OF THE NOTE	Kalem	3	FAIR REBEL	K. & E. Biograph	3
HER LADYSHIP	Selig	3	HOUSE NEXT DOOR	Lubin	5
GOODNESS GRACIOUS	Vitagraph	3	MY OFFICIAL WIFE	Vitagraph	5
OFFICER JIM	Lubin	3	UNCLE BILL	Vitagraph	3
DEATH SIGN AT HIGH NOON	Kalem	3	THE FORTUNE HUNTER	Lubin	6
GAME OF LIFE	Selig	3	THE VENDETTA	Kleine	5
THE MILITANT SUFFRAGETTE	Pathe	5	BAREFOOT BOY	Kalem	3
FRANCIS MARION, "THE SWAMP FOX"	Kalem	3	THE WIFE	K. & E. Biograph	3
A MILLION BID	Vitagraph	5	KING OF CHANCE	Kalem	3
THE FATAL WEDDING	K. & E. Biograph	3	THE WAGES OF SIN	K. & E. Biograph	3
THE GAMBLERS	Lubin	5	THE PLUM TREE	Essanay	3
ANNE BOLEYN	Kleine	3	THE FIFTH MAN	Selig	3
STRUGGLE FOR LIFE	Pathe	5	THE GOLDEN BEETLE	Kleine	4
MONGREL AND MASTER	Essanay	3	THE WEIGHT OF A CROWN	Lubin	3
THE ROYAL BOX	Selig	4	MARAH, THE PYTHONESS	Lubin	3
THE CURSE OF CREED	Melies	5	CHARITY BALL	K. & E. Biograph	3
FACING THE FOOTLIGHTS	Pathe	3	HEARTS AND MASKS	Selig	3
BLOOD WILL TELL	Essanay	3	A FLORIDA ENCHANTMENT	Vitagraph	5
CONQUEST OF QUEBEC	Kalem	5	ROAD TO YESTERDAY	K. & E. Biograph	3
THE LILY OF THE VALLEY	Selig	3	THE PAINTED WORLD	Vitagraph	3
CLASSMATES	K. & E. Biograph	4	JUDGE NOT	Kleine	4
MAN OF THE HOUR	Selig	3	GARRISON'S FINISH	Selig	3
MR. BARNES OF NEW YORK	Vitagraph	6	POWER OF THE PRESS	K. & E. Biograph	4
LOVE, LUCK AND GASOLINE	Vitagraph	3	IN THE GLARE OF LIGHTS	Essanay	3
THE BILLIONAIRE	K. & E. Biograph	3	THE RED CROSS NURSE	Melies	3
SPORT AND TRAVEL IN CENTRAL AFRICA	Pathe	5	THE THREADS OF DESTINY	Lubin	5
THE GOOD FOR NOTHING	Essanay	4	WHEN THE LIONS ESCAPE	Melies	3
THE BOER WAR	Kalem	5	THE GENIUS	K. & E. Biograph	3
THE THUMB PRINT	Melies	4	STONEWALL JACKSON'S WAY	Lubin	3
STRONGHEART	K. & E. Biograph	3	THE INVISIBLE POWER	Kalem	4
LORD CHUMLEY	K. & E. Biograph	4	THE WOMAN IN BLACK	K. & E. Biograph	4
SEVEN DAYS	K. & E. Biograph	3	UNDER THE GASLIGHT	K. & E. Biograph	4
TREASURE OF ABDAR RAHMAN	Pathe	4	"413"	Vitagraph	3
'NEATH THE LION'S PAW	Melies	3	THE WIN(K)SOME WIDOW	Vitagraph	4
ONE WONDERFUL NIGHT	Essanay	4	THE STORY OF THE BLOOD RED ROSE	Selig	3
WOMAN AGAINST WOMAN	K. & E. Biograph	3	THE TELL TALE HAND	Essanay	3
IN DEFIANCE OF LAW	Selig	3	A POOR RELATION	K. & E. Biograph	3
A KINGDOM AT STAKE	Kleine	3	THE LOCKED DOOR	Vitagraph	3
CAPTAIN ALVAREZ	Vitagraph	6	THE TANGLE	Vitagraph	4
OTHELLO	Kleine	5	THE SPY'S FATE	Lubin	5
SHANNON OF SIXTH	Kalem	5	IN THE DAYS OF THE THUNDERING HERD	Selig	5

WILLIAM FOX ANNOUNCES

Current Releases

LIFE'S SHOP WINDOW 5 Reels by Victoria Cross
ST. ELMO 6 Reels by Augusta J. Evans

Smashed all box office records wherever shown from Maine to California. Wire, write or call at nearest exchange for bookings.

Coming Releases Extraordinary from William Fox Studios

Play	Stage Producer	Author	Reels	Artist
THE WALLS OF JERICHO	James K. Hackett	Alfred Sutro	5	Edmund Breese
THE THIEF	Daniel Frohman	Henri Bernstein	5	Dorothy Donnelly
THE IDLER	Charles Frohman	C. Haddon Chambers	5	Charles Richman
THE GIRL I LEFT BEHIND ME	Charles Frohman	David Belasco	5	Robert Edeson
CHILDREN OF THE GHETTO	Liebler & Co.	Israel Zangwill	5	Wilton Lackaye

and fifty more successes from the pens of the World's greatest authors, produced with skill and care, each play headed by a famous actor or actress, surrounded by an all-star cast.

The Box Office Attraction Company also releases three features weekly, lengths from 2800 to 3500 feet; also single reel comedies.

THE BOX OFFICE ATTRACTION CO.

WILLIAM FOX, President.

Executive Offices, 130 West 46th St., NEW YORK

NEW YORK, 130 West 46th Street, Phone BRYANT 7340

CHICAGO, Mollers Building, Phone CENTRAL 1716

CLEVELAND, Columbia Building, Phones MAIN 5677, CENTRAL 6260 R.

PHILADELPHIA, No. 1333 Vine Street, Phone WALNUT 4503-4

DALLAS, No. 1907 Commerce Street, Phone SOUTH WESTERN MAIN 2066

MINNEAPOLIS, Jeweller's Exchange Building, Phone NORTHWESTERN NICOLLET 2498

ST. LOUIS, No. 3632 Olive Street, Phones BELL-TINDELL 795, Kinloch, Delmar 4363

SAN FRANCISCO, No. 107 Golden Gate Ave., Phone MARKET 4880

PITTSBURGH, No. 121 Fourth Avenue, Phone COURT 1302

SYRACUSE, Eckel Theatre Building, Phone WARREN 119

BOSTON, No. 10-12 Piedmont Street, Phone OXFORD 6254

KANSAS CITY, No. 922 Main Street, Phones BELL MAIN 1008, HOME MAIN 7253

DENVER, Ideal Building, Phone MAIN 5071

SEATTLE, 1214 Third Avenue, Phone ELLIOTT 1039

I am ZUDORA—the mystic girl detective you've heard so much about. I'm just eighteen. I'm playing the lead in Thanhouser's new serial photoplay — ZUDORA. This will be Thanhouser's masterpiece. It has been created by Daniel Carson Goodman author, scientist, philosopher. It has been novelized by Harold MacGrath and will appear in 500 leading newspapers.

ZUDORA

Thanhouser's Greatest Photoplay

This stupendous production will be presented in 20 episodes—each a baffling and perplexing mystery. These episodes represent 20 episodes of my life. Each will be complete in itself—although a master plot will run through all. A new episode will be released each week beginning Monday, Nov. 23.

I am ZUDORA—endowed with supernatural powers of deduction, hypnotism and scientific analysis. I will present to the public, beginning Nov. 23rd, the story of my odd powers—an extraordinary recital of science, love and adventure.

I've promised exhibitors *bigger box office receipts*. I'll be with you beginning November 23rd to make good.

—ZUDORA.

Exhibitors who wish to book this remarkable attraction must apply AT ONCE to Syndicate Film Corporation's representative at any Mutual Exchange in America.

Thanhouser Syndicate Corporation
71 West 23rd St., New York City

Produced by the Syndicate Film Corporation, New Rochelle, N. Y., Producers of The Million Dollar Mystery



Trade Mark Reg.



Trade Mark Reg.

204

Motion Picture News

HAS THE QUALITY CIRCULATION OF THE TRADE

"When You See It
In 'The News'
It's NEWS"

"The Exhibitors'
Medium of
Communication"

Tel. 7650 Bryant

NO. 220 WEST FORTY-SECOND STREET

New York City

Volume X

NOVEMBER 14, 1914

Number 19

MINNESOTA CONVENTION A MODEL MEETING

Resolutions Adopted by Exhibitors in Minneapolis Go to the Root of Conditions and Prove Members Alive to the Importance of Remedying Existing Circumstances—Exchange Men Participate in "Get-Together" Conferences—Committees Appointed—More and Shorter Sub-Titles Wanted

WORKING with the same earnestness and lack of friction that would characterize the meeting of a board of directors for a successful corporation, members of the Minnesota Motion Picture Exhibitors Association at their fall meeting and exposition put the motion picture business into the big business class.

It is usually considered polite and quite the necessary thing for the delegates to boost a convention whether it really did anything or not. However, when a large group of exhibiting manufacturers ask special permission to go on the floor to thank the convention and to ask them to have another exhibition, there is something more than politeness in the boost.

These manufacturers sold goods, sold expensive goods and lots of them, and the ones who are loudest in praise are the ones who exhibited reluctantly.

Then again, in checking over the list of 347 delegates registered it was found that the majority of them represented theatres that cost an actual outlay of more than \$12,000.

When the delegates once got inside the convention hall in the West Hotel business only was considered, and every man left thoroughly convinced that the motion picture business in the northwest is many notches higher than before, that the association is an efficient, service-rendering organization, and that it is strong enough to fight and win any just battle undertaken.

The convention did many things, gave serious consideration to many more, and filled every exhibitor with enthusiasm.

As an example of the harmony, time after time, resolutions were read and one member would say: "I believe it's too early for the association to try that."

"I guess that's right, read the next," would be the response from all parts of the house, the man who offered the resolution joining the chorus.

Important Action Taken

There is food for serious thought in the proceedings for manufacturers and exchange men. The action taken was entirely without malice, but indicated a firmness of purpose. The association decided to pay no more return express charges on any films; to use no special feature films of the regular companies unless they are on the regular program.

Other matters decided upon were:

Appointment of a board of review to see all state rights films, and report on condition of film and general subject matter—a small fee to be charged for review and report sent to every exhibitor;

the establishment of a commission to adjust grievances and differences between exhibitors and exchanges.

It was also decided to establish a permanent legislative committee in the twin cities to look after all motion picture legislation; to have all members report to the secretary on the price he pays for service, and to see if discrimination is shown.

Manufacturers will be asked to eliminate from films and posters all cigarette smoking, drinking and carousing scenes, and other scenes likely to wrongfully influence the young and increase censorship agitation.

Manufacturers will be requested to adopt standard sizes of posters and other advertising matter that uniform frames may be used, and to discourage the distribution of any films that are not clear.

Manufacturers will also be asked to discourage the use of serial pictures unless they are on regular programs.

The association wants to expand the organization and take members from Wisconsin, North and South Dakota, and make every exhibitor member an organizer and membership solicitor.

Effects of Discussion

The discussion of the big things in the business was an education to every delegate. Each discussion showed that the exhibitor has his side, and that the exchange man and manufacturer has his.

The delegates "reasoned together." An instance of this was the frequent suggestion that some men were paying more for features than others. They didn't see the reason.

J. F. Cubberly, manager of the Zenith Feature Film Company of Duluth, and an exhibitor as well, told why this was so.

"There is nothing to conceal about this," he said. "Two men just asked me for prices on a certain feature. I quoted the same film to one man at \$12 and to the other at \$20. The man who got it for \$12 is in a town of 1,500 population, and the other in a town of 5,000.

"I believe we must adjust the prices in this way, taking into consideration the size of the town and the size of the house when we go outside the city. If we did do this the small man would fail to get the good pictures his audiences deserve. I have worked constantly to give the small towns the best on the market at a price their houses are able to pay."

Mr. Cubberly dealt with these two men at the same time and said that the exchange men should all work on this basis and be firm about it.

**The Editorial by William A. Johnston
will be found this week
in The Accessory News—See page 71**

Mr. Cubberley's idea was favored by many with certain modifications, and this question will be one of the important ones to be threshed over by the grievance committee before the next meeting.

Other important suggestions to be considered by committees are proposals to:

Want More Sub-titles

Obtain some special concession or benefit exclusive to the Minnesota association that will make membership something to be desired by every exhibitor.

Ask manufacturers to use more sub-titles and larger type, and simple short words that can be grasped quickly by everyone.

Request manufacturers to announce the names and show pictures of the film stars so the patrons will become better acquainted with them and take more interest in films.

"THE EXHIBITORS' TRADE JOURNAL"

MOTION PICTURE NEWS,
New York City.

Gentlemen: I want to tell you that the Motion Picture News was a mighty popular trade journal among the exhibitors who attended the recent convention at Minneapolis. Exhibitors from the small towns, as well as the cities, were loud in their praise of the News.

"The exhibitors' trade journal" was the slogan they all adopted. I am sorry that my work on subscriptions was largely effort wasted. Nine out of ten exhibitors present already are subscribers.

Very truly yours,

FRED S. MEYER.

Organize locals wherever expedient.

Keep state organization out of national affiliation.

Study, boost and build the motion picture business.

Rumors of proposed censorship bills and other legislation affecting the business is expected to make a midwinter meeting necessary, and that will be subject to the call of the president.

The association found time for many social functions, but none of them interfered with business.

One of the delights of the convention was the address of Mayor Wallace G. Nye. Mr. Nye said the motion picture business had been placed on a high plane in Minneapolis, and he declared that "no licensed calling" gave him as little concern as the motion picture calling.

"I have always found the picture men ready and willing to work for the best interests of the city, and I wish that all other business men were as willing," he said. "Where I have suggested betterments they have been made even where it meant loss for a time at least to the exhibitors. I congratulate you on your efficient organization, your high standards of citizenship, and the city is yours now or any other time."

Everybody Pleased

The exhibitors helped make the exhibition lively. The big balcony and second floor of the hotel was packed with them, and all did business. Those men who deal in any supplies that exhibitors use will exhibit hereafter, and the exhibition was half of the meeting.

Harry H. Green and W. A. Steffes, with their committees, handled the job which many said couldn't be done. The association was appreciative, and so are the civic bodies of Minneapolis and next time the exhibitors of the city want anything other organizations will go out to help them land it.

R. G. MARSHALL.

Sidelights of the Convention

The following committees were appointed:

For the Good of the League: Nicholas, Fairmont, Minn., chairman; Baloo, of Albert Lea, Minn.; Granstrum, St. Paul, Minn.; Abrahamson, Duluth, Minn., and C. E. Van Duzee, Minneapolis.

Grievance Committee: O. C. Stelzner, Minneapolis, chairman; D. F. Eislein, Cloquet, Minn.; P. D. Agnew, Minneapolis; Mr. Bye, of Minneapolis, and Mr. Hagen.

Committee for Ways and Means: Otto N. Raths, St. Paul, chairman; Jas. Gilowsky, St. Paul; Frank Nemece, St. Cloud, Minn.

Executive Committee: W. A. Scott, Red Wing, Minn.; E. A. Nelson, Duluth, Minn.; F. E. Nemece, St. Cloud, Minn.; Christopherson, of Benson, Minn.

Among the manufacturers represented were the following:

Sterling Electric Company, Feature Film Company, St. Paul; National Cash Register Company, Grant Sign Company, Plank Disinfection Company, Milwaukee Poster Mounting Company, Wisconsin Seating Company, MOTION PICTURE NEWS, Arcus Ticket Company, General Film Company, Eclectic Film Company, Alco Film Company, Universal Film Company, Warner's Film Company, World's Film Company, Famous Players Film Company, Great Northern Film Company, Mutual Film Company, George Kleine Film Company, and Box Office Attraction Company.

Just before the convention adjourned to meet at the call of the president, the chairman requested the various exchange men and every one who was present to speak a few words with reference to his exhibit.

"Is the gentleman who is representing the MOTION PICTURE NEWS present?"

Fred S. Meyer, who represents the circulation department in the Northwest, arose, and took the floor.

Chair.: (Jas. Gilowsky, of the Alhambra and Gem theatres, St. Paul.)

"Gentlemen: I wish to say one word in behalf of MOTION PICTURE NEWS. I receive all of the trade journals at my theatre and have been getting them for a good many years. Not until lately did I subscribe to the NEWS and I am satisfied to go on record in stating that the NEWS, without exception, is the best and liveliest trade journal on the market today, and of particular interest to northwestern exhibitors; and you will make no mistake when you subscribe for the NEWS."

Mr. Meyer: "Mr. Chairman, Ladies and Gentlemen: I did not expect to be called upon to make an address, at least not in behalf of the MOTION PICTURE NEWS. As you of course know, I am connected with the Laemmle Film Service, and my associations with that firm prevent me from actually representing the NEWS in an editorial capacity at all times. I realize the fact that at executive sessions it is impossible to be present, and that ground has been and is supposed to be covered by another gentleman.

HE WOULDN'T BE WITHOUT IT

Minneapolis, Minn., Oct. 31, 1914.

MOTION PICTURE NEWS,
New York City.

Gentlemen: "From a house manager's standpoint, the Motion Picture News is great, and indispensable, and under no consideration would I be without it."

HARRY L. BECK, Manager,
Wolf Point, Mont.

Everybody Agreed

"What I am looking after is the circulation end and it is no wonder that I have again been successful in proving beyond a shadow of a doubt the unusual popularity of the MOTION PICTURE NEWS. I wish to thank you personally, Mr. Chairman, for the very kind words of introduction. From the bottom of my heart I extend my appreciation to Messrs. Steffes and Green, in fact you all have been so very kind, and loyal in your boosting of the MOTION PICTURE NEWS, that I fail to see how I can ever at any time reciprocate and repay you for your kindness.

"With regards to the MOTION PICTURE NEWS, all I can say is that you can consider this paper for the exhibitor, first, last and all the time. An opportunity arose some months ago, when Mr. Steffes (at the time of Mr. Neff's attempted organization of a League at Austin, Minn.) requested me to send a few lines to the MOTION PICTURE NEWS. I did so, but had no idea that said article would be published in its entirety. It was, and I don't think I am mistaken in stating that the MOTION PICTURE NEWS directly, and Mr. Steffes and his wonderful article indirectly, are responsible for the fact that Mr. Neff is no longer president of the national organization.

"I do not wish to dwell upon politics. As previously stated,

(Continued on page 44.)

WASHINGTON BALL IS BIG SUCCESS

Exhibitors League Function, Looked Forward to with Deep Interest by Members of the Industry in and Out of the Capital City, Proves an Occasion of Joyful Celebration, and Will Be Long Remembered in the Annals of the Association

Special to MOTION PICTURE NEWS

Washington, D. C., Nov. 3.

THE most unique gathering the capital of the nation has ever known was that of the ball and reception given on Hallowe'en night by the local Motion Picture Exhibitors League and the Washington "Post." Convention Hall was turned into a fairy palace with palms, bunting, flags, and electric lights, amid which moved an animated throng in beautiful attire.

A large orchestra, under the direction of A. J. Manvell, furnished a concert program until 9 o'clock after which dancing began and continued until midnight. At least three thousand attended the ball, whose informal nature created a congeniality which added to the thorough enjoyment of all.

The chief point of expectancy was the entrance of the players, which occurred at

Price, Norma Talmadge, Edith Story, Mary Maurice, Clara Kimball Young, Marion Nesbit, Gertrude McCoy, Mabel Trunelle, Clary Lambert Daly, Florence Hackett, Justina Huff, Rosetta Brice, Lillie Leslie, Ruth Bryan, Elsie Woodward, Mildred Gregory, Clarence J. Elmer, William Kerry, Kempton Greene, Ormi Halley, Mayme Kelso, Romaine Fielding, Mr. and Mrs. A. V. Smith, Samuel Spedon, H. A. D'Arcy, and Frank Mann.

Open regret was expressed at the non-appearance of Francis X. Bushman, from



WILLIAM P. HERBST

it must be admitted that Fulton Brylawski was the moving spirit of the event. Every exhibitor gave his support and it was these united efforts that will make this first "Movie Ball" long remembered by the public of Washington.

THEODORE FRANKLIN.

PECK ASSISTANT MANAGER FOR BALBOA

Special to MOTION PICTURE NEWS

Los Angeles, Nov. 2.

Charles Mortimer Peck, former newspaper man, and until recently connected with William Fox's Box Office Attraction publicity department, has arrived on the West Coast and taken up the duties of assistant general manager of the Balboa Amusement Producing Company at Long Beach, Cal.

It is understood that H. M. and E. D. Horkheimer, owners of the company, will in the near future open an office in New York City and one partner will be there all of the time, and both a part of the time; thus the management of their producing company on the West coast will be looked after in their absence by Mr. Peck.

WHERE TO FIND IT	
Department	Page
Live Wire Exhibitors.....	27
Among the Exchanges.....	29
In and Out of Los Angeles	
Studios	35
Editorials	33
Feature Reviews	39-44
Program Reviews.....	47, 48
Buyers' Guide	49
Current and Coming Releases,	
	50, 52
Release Dates for Ready Ref-	
erence	54, 55, 57
ACCESSORY NEWS.....	69-82

whom a telegram was read, stating that special rehearsals prevented his coming. There was also present a contingent from the Baltimore League, headed by Marion Pearce, president of the National League.

An interesting feature of the ball was the taking of a motion picture of the grand march of the players, as well as the public who followed in the procession. This will be shown at the local theatres. It is needless to say that the motion picture actors and actresses were fairly besieged by the enthusiastic public. There was no partiality:

All were equal favorites. As each was introduced by Fulton Brylawski, secretary of the local league, the players expressed happiness to know and meet so many friends and admirers.

A banquet followed the ball at which about one hundred and fifty covers were spread. The many favors were emblematic of the occasion and the spirit of Hallowe'en prevailed. This was a gathering of beauty, animation and good fellowship.

The toastmaster was John Smiley, and those who were called upon to address the assembly were Marion Pearce, Wm. P. Herbst, King Baggott, Harry Myers, Kate Price, Harry Crandall, Fulton Brylawski, Marc McDermott, and Romaine Fielding. Mr. Pearce took this occasion to present to the Washington League a souvenir of the Dayton convention, consisting of photos and badges of this gathering appropriately framed.

The whole affair was a huge success, but



FULTON BRYLAWSKI

10 o'clock in the form of a promenade grand march led by Earl Williams and Clara Kimball Young. Then followed the other players—heroes and heroines, comedians, villains and adventuresses, sweet-hearts and lovers—who from the screen had endeared themselves to the public.

Those from the various studios were as follows: Earl Williams, King Baggott, James Morrison, Hughie Mach, Marc McDermott, Ben Wilson, Harry Myers, Wallie Van, Alan Quinn, Howard Mitchell, Earl Metcaff, Robert Cornes, John Smiley, James Daly, Lloyd Lonegran, Edgar Jones, Harry Morey, Douglass Sibole, John Ince, Donald Hall, Lillian Walker, Rosemary Theby, Anita Stewart, Leah Baird, Kate

WATCH ACCESSORY NEWS
Pages 69 to 82

Censors Superfluous, Coast Censor Declares

Chairman of Los Angeles Board Asserts Pictures Have Improved So Much They No Longer Need Supervision By the City Authorities

Special to MOTION PICTURE NEWS

Los Angeles, Nov. 2.

THE manufacturers of motion pictures have so improved their productions in the past three years that for men and women to sit as a board of censors now is a pure waste of time and energy. This at least is the opinion of Mrs. E. K. Foster, chairman of the Los Angeles municipal board of censors, who for the past three years—or since the board was established by the passage of a city ordinance—has held that position.

"The position was wished on me while I was absent from the city on a trip in Europe," Mrs. Foster explained to a "News" representative. "Upon returning home I was told of my appointment and at the insistence of friends I accepted. Pictures then were cheap and daily we ordered eliminations and very frequently recommended that a film not be shown.

"This condition does not exist now. The orders for eliminations are now very few and it is seldom the board condemns a picture. The improvement in pictures is largely due to censorship throughout the country, I believe, and the hearty cooperation of manufacturers. Practically every producer now gives instruction to scenario writers to eliminate all murder, suicide, seduction and similar criminal scenes. All—that is the better companies—are working for better pictures,

free from what might be termed filth, but there are a few who desire to profit by producing shoddy pictures that appeal to a very small class. American pictures—generally speaking—are far superior to foreign made films.

"Yes, so-called thrillers and slap-stick have a place. They serve as amusement to a class that should be entertained for their health's sake. There should be no censorship, with reference to children, for parents and guardians should see that their children do not go where they should not.

"Los Angeles board members are not of the same class as those of Chicago and Philadelphia. This is not a censorious board. We have aimed to act as a health department for pictures, removing the filth and leaving all recreation and educational features.

"All members are believers in the saying of Herbert Spencer, 'Protect men from their follies and you breed a race of fools,' and have practiced the doctrine while censoring films."

It is very probable recommendations will be made to the city council in the near future pointing out the lack of need of the censor board, and recommending that an inspector be appointed by the mayor, whose duty it will be to supervise films, or urging that the matter be taken charge of by the state or nation.

Prosperity Paramount In Omaha Territory

Demand for Higher Grade Service Increases—Better Machines Ordered—Improvements and Alterations Everywhere Going On—War Has No Effect

Special to MOTION PICTURE NEWS

Omaha, Neb., Nov. 2.

THE fall prosperity of motion picture houses in this territory is being realized more than ever this year. Exchange managers report increasing demands for higher grade service. Every building in the territory that is in any way fitted for a motion picture theatre is being used for that purpose, and all of them are enjoying prosperity.

C. E. Jones, at the head of the repair and supply department of the Mutual exchange here, says there is a continual stream of orders for better and higher grade machines, more improvements and general signs of prosperity. Jones, in going about to visit the various exhibitors, has personal talks with nearly every one of them during the course of his work. "Everybody is delighted with their business this fall," he said.

A new theatre opened in Omaha October 24, and one opened in Council Bluffs, Ia., just across the river, on October 28. Out in the state repairs, improvements and new theatres have been listed in nearly every town. The motion picture exhibitor population of this territory, heretofore lower in proportion than most other states, is gradually increasing. This winter is expected to give the business such an impetus that this territory will be a boom one within a year.

The war has not affected this territory, as it has elsewhere. In the manufacturing cities there has been a let-up in general prosperity because of decreased exports, resulting from the war. Here, however, where the food—always needed—is produced, there is a prosperity marked in contrast with other parts of the country. Nebraska's prosperity is and has been for several weeks a national subject. Better crops than for years were produced, and they brought better prices than for years.

"MAN FROM HOME" NEW LASKY RELEASE

"The Man from Home," the famous Liebler Company Astor Theatre success which was booked for the Strand Theatre, is the most recent output of the Jesse L. Lasky Feature Play Company, and has at the head of the cast Charles Richman.

In the photo play The Lasky Company spared neither pains nor expense to make the production even more massive and finished than the stage production. In addition to Mr. Richman, the cast contains James Neil, Theodore Roberts, J. W. Johnston and a new find of the Lasky directors, Florence Dagmar, who plays one of the principal roles.

"The Man from Home" is scheduled for release on November 9, and will have its first showing in New York at the Strand Theatre.

OLGA PETROVA LATEST STAR OF POPULAR PLAYERS

Popular Plays and Players, Inc., has just added a new star. Madame Olga Petrova, the Russian actress, makes her debut in motion pictures under their auspices. Her vehicle is "The Tigress," a picturization of



OLGA PETROVA

Ramsay Morris's play, which in turn was based upon Mr. Morris's novel.

Madame Petrova is playing in New York in "Panthea." Her appearance as a moving picture star is thus made possible at this time by her presence in New York. Each morning the actress will go to the new studios of the producing organization at Fort Lee.

In "The Tigress," her managers declare, Madame Petrova has been fitted with a vehicle which exactly fits her temperament. The actress has many strong scenes to do in the vein in which the general public is accustomed to think of her and so her admirers and friends believe that she will be very successful as a motion picture star.

BALTIMORE ASTIR OVER PHILADELPHIA MEETING

Special to MOTION PICTURE NEWS

Baltimore, Nov. 4.

There is much interest at the Baltimore headquarters of the Motion Picture Exhibitors League of America regarding a big meeting of exhibitors expected to be held shortly in Philadelphia.

While this meeting will be strictly a Philadelphia or Pennsylvania exhibitors' gathering, it is expected that all of the prominent officers of the league will be invited to be present. The meeting will be of a general get-together nature to discuss the welfare of the motion picture industry in the Keystone State.

The Modern Magic of Screen Advertising

By Watterson R. Rothacker

Industrial Motion Picture Publicity One of the Strongest Factors in Business Today—Its Undisputed Power in Creating a Demand for the Products of Manufacturing Concerns—It Combines Amusement and Instruction While Subtly Impressing the Merits of the Goods

THE fact that motion pictures are now engaging the careful attention of advertising agents and advertisers everywhere, coupled with the amazing record of actual motion picture advertising achievement, has brought into transient being a host of alleged motion picture advertising specialists who either intentionally or ignorantly are making ordinary film and preposterous circulation claims decidedly detrimental to the best interests of this field.

Motion picture manufacturers realize that it takes more than a camera, a pint of Kodak experience and an unbacked ambition to make films photographically good. Any student of advertising knows well that the science of advertising consists of more than parroted ideas and a superficial vocabulary of selling phrases.

Era of Specialization

Ours is an era of specializing. Now that motion pictures have an established place in the list of advertising media, the introduction of the film advertising specialist is accomplished in the same manner the advertising world was made to accept and value the individual or company announcing as their specialty copy writing, direct merchandising, newspaper, magazine, billboard or poster advertising.

Motion picture advertising is too big and important for a side-line. To be a capable manufacturer of good film, or to be an able advertising expert, is each in itself a splendid achievement.

On the other hand, there are many advertisers using, or intending to use, pictures for indirect advertising, special propaganda work or sales promotion purposes who can, without the services of a recognized moving picture advertising specialist, make a creditable showing and a good film investment, provided their moving pictures are taken by some one of the reputable manufacturers who can and do back their proposition by something more tangible and satisfactory than absurd assertions.

The maximum of moving picture advertising efficiency can be secured by doing business with a reliable moving picture advertising specialist who has the advertising ability and experience, the necessary moving picture manufacturing ability and experience, factory, field and service organization, plus an honest intention to sincerely "make good" the fulfillment of contracts when signed to the extent promised when soliciting the business.

Moving picture advertising results can also be obtained where the advertiser delegates his advertising or sales manager to direct the work and then has it done by one of the film manufacturers whose trade-mark or name stands for real moving picture quality. Where this course is pursued, of course, there will

often be a lack of footage economy and the advertiser will have to furnish the ideas, see to it personally that they are put on the film right, and will have all details of special exhibitions and circulation to handle.

Until recently the moving picture industry has been pleasantly free from stock jobbing schemes, but the wave of popularity and publicity given the animated pictures has attracted the Wallingford promoters, whose records in most instances can be summed up in the phrase: "Successful promoters of unsuccessful enterprises." The "dear public" holds the bad and where the schemer turns to the industrial and advertising field some advertisers are bound to do a little holding themselves.

Firms Using Picture Publicity

In the list of big users of motion pictures for advertising, commercial education or industrial exploitation, are such organizations as the Winchester Repeating Arms Company, Postum Cereal Company, Du Pont Powder Company, Northern Pacific Railway Company, Peabody Coal Company, United States Gypsum Company, Imperial Oil Company, American Cyanamid Company, Old Taylor Whiskey Company, United States Brewers Association, Barber Asphalt Company, International Harvester Company, Peabody Houghteling & Company, Ford Automobile Company, United Shoe Machinery Company, Shredded Wheat Biscuit Company and dozens of others noted for their ability and policy to buy good and safely, and whose selection of motion pictures as an advertising means is in itself sufficient to prove that this form of advertising comes through the acid test O. K.

Illustrations have an acknowledged place in advertising. Motion pictures are undoubtedly the superior illustrative force. The tendency in advertising copy is to suggest or state the magnitude of the advertiser's organization, the factory back of his trade mark or name, the care with which his product is made and distributed.

More words cannot adequately do this, but where these advertising claims will stand for pictorial proof, moving pictures can be utilized to show in motion, comprehensively and convincingly, all that the advertising copy attempts to conjure to the mind's eye.

On account of certain restrictions with which reputable film manufacturers and honest moving picture advertising specialists are familiar and acknowledge advertising films cannot be shown in all of the picture theatres in this country. But a goodly number of these houses can be induced to give ad. films splendid and far-reaching circulation if the subject is properly produced and presented through

channels known and open to those who have gone into the business on the right basis.

Moving picture ads. on the screen engage 100 per cent. eye and mind attention, for where the pictures are shown there are assembled people in their most receptive mood who are there to see and are undisturbed by diverting or distracting influences.

There is a world of romance behind every business name and trade mark. The capable and thinking moving picture advertising specialist can find this romance, film it and put it before the public in a manner that will attract, entertain, educate and at the same time deliver an advertising message in a manner decidedly favorable to the advertiser.

Motion picture advertising can be directly connected with merchandising schemes; it can be made to move merchandise. In fact, it can be made to do most anything that appeals to the eye, but it takes more than mere talk and intentions to deliver.

Film Advertising Possibilities

Moving picture advertising possibilities have been prostituted and perverted by solicitors who brazen their way into the advertiser's office and either through ignorance or ulterior motive claim and promise circulation that cannot be delivered.

Many a good prospect has been "killed" by the employing of firms unable to make good films.

More than one advertiser has been disgusted and shoved back into the future prospect file by a presentation of glaringly false claims which were apparent even to him, a layman, and a reflection upon his business intelligence.

There are instances where the advertiser has had good motion pictures made, and then because his contract did not buy service he has found good reels on his hands which he knew not how to place where they could earn dividends.

Judging from the quotations that have been given to prospective advertisers, the price for pictures is more elastic than a rubber band. As a matter of fact, there should be a standard price. It is possible to induce an advertiser to pay \$2.50 a foot for film. Of course, this is exorbitant, and a firm taking advantage of the average layman's ignorance of such matters cannot hope for success very long.

On the other hand, there are quotations of thirty and forty cents a foot, which are below the proper cost and cannot possibly be made profitably if this price includes any advertising or circulation service, unless the film company taking business at this price loads up the customer with a lot of "dead action" and repetition, which is unnecessary footage.

Screen Club Organized in San Francisco

Exhibitors and Exchange Men Launch Association for Purpose of Bringing Pacific Coast Members of Industry in Closer Touch

Special to MOTION PICTURE NEWS

San Francisco, Nov. 2.

THE Screen Club of San Francisco has been organized here by leading exhibitors and film exchange interests, following a series of discussions on the subject at the informal luncheons held each Saturday by members of the trade at a prominent downtown cafe.

The need of a social organization to bring exhibitors, exchange men, producers and equipment agents into closer touch with each other has been apparent for some time, and for several weeks plans have been under way for the formation of a permanent body of this character. A formal meeting was held on the evening of October 19 at which an organization was effected and officers chosen.

Following the initial meeting, a two days' canvass for membership was made and during this time fifty charter members were secured, making a splendid nucleus for the organization.

Arrangements are now being made for opening club rooms and by the opening of the exposition year the club hopes to be in its own quarters and in a position to properly care for visitors of note.

Funds for the furnishing of the club rooms are to be raised through the medium of a ball to be held at the Coliseum rink on the evening of November 28, and the initial plans for this event indicate that it will be one of the most unique events of the kind ever held in this city.

The publicity end of the affair is being handled by Joseph Huff, of the Odeon and Unique theatres, thus insuring something new. The ball is in the hands of the following committee:

J. T. Turner, of Turner and Dahnken;

Leon Bories, General Film Company; M. L. Markowitz, California film exchange; Charles Stillwell, Silver Palace theatre; J. MacArthur, Majestic theatre; F. L. Hudson, Eclectic film exchange; Joseph Huff, Unique and Odeon theatres; Jack Partington, Imperial theatre; Marion H. Kohn, Apex Film Company; Sol Lesser, Golden Gate film exchange; Tom North, George Kleine Attractions, and Fred Dahnken, Turner and Dahnken.

The officers of this late addition to the screen clubs of the country are:

President, Sid. Grauman, manager of the Empress theatre and part owner in Grauman's Imperial; vice-president, Chas. Stillwell, manager of the Silver Palace theatre; secretary, Nate K. Herzog, of the Pastime theatre; assistant secretary, Ralph L. Marks, secretary of the Exhibitors' League of San Francisco; treasurer, J. T. Turner, of Turner and Dahnken; directors, Sol Lesser, of the Golden Gate Film Exchange, Inc.; Tom North, manager of the San Francisco office of George Kleine Attractions; O. V. Traggardh, of the Union Film and Supply Company, and the Supreme Features Corporation; Joseph Huff, manager of the Odeon and Unique theatres; Ralph L. Marks, of the Acme theatre on Stockton street.

16 LOUISVILLE HOUSES BOOK "ZUDORA"

Special to MOTION PICTURE NEWS

Louisville, Nov. 4.

J. G. CONNER, of Indianapolis, representative of the Thanhouser Film Corporation, was in Louisville recently and contracted with sixteen of the leading motion picture theatres in the city for the production of the new photo-play, "Zudora."

On this basis of figuring, the paramount purpose must be to concentrate and accentuate the important features of the subject, so that its advertising power is developed to a maximum and the customer does not have to pay for waste film footage, which is an extravagance.

There is sufficient advertising value in motion pictures. There is no need for misrepresentation. It is not necessary to make exaggerated circulation claims to get a customer. Motion pictures constitute the greatest advertising forces ever conceived. Wherever a moving picture advertising contract is secured and fulfilled on a safe, sane and sincere basis, the advertiser makes a wonderfully profitable advertising investment, and the specialist builds stronger for the future, for isn't it true that the proof positive of any proposition is the record and face value of the people who make it and the aftermath the opinion of those who accept it?

Seeing is believing; hence, moving pictures for advertising—but, SWAT THE LIE IN MOVING PICTURE ADVERTISING.

MONTANA PRESIDENT IN R. R. ACCIDENT

Special to MOTION PICTURE NEWS

Butte, Mont., Nov. 2.

Philip Levy, manager of the Ansonia Amusement Company of this city and president of the Montana Exhibitors League, was near death on the North Coast Limited, the crack train of the Northern Pacific, in the Cascade mountains.

Just as the train pulled slowly out of a long tunnel in the mountains, the driving rod broke and the cars came to a sudden stop, caused by the severed rod sticking in the ground.

Because of the slow rate of movement, there was no accident but the jar and the smoke filled carriages, caused by the tunnel ride, gave out the impression for a moment that the train was afire. In pajamas, Mr. Levy and others tumbled out of bed to enquire the accident. Ascertaining the truth they returned to bed and slept for the three hours while a new engine was being procured from a nearby station.

Mr. Levy was returning home from a business trip to Seattle.

20 MANAGERS AT SYRACUSE PROTECTIVE MEETING

Special to MOTION PICTURE NEWS

Syracuse, N. Y., Nov. 2.

Twenty of the sixty motion picture managers of this city met at the hotel Onondaga recently with Arthur J. O'Keefe general organizing representative of the United Managers Protective Association and listened to a plea put forth for joining the big organization.

Frank P. Martin of the Wieting theatre called the meeting and Manager Bert Gibbons of the Warner Feature Film Company presided. It was practically unanimously decided to join the national body and after other exhibitors are invited and all who care to have signified intentions of becoming members, election of local officers will be held.



WHEN TRUTH HOLDS HER MIRROR UP TO LIFE
Scene from "Hypocrites!" (Bosworth-Paramount Feature)

BUSINESS OUTLOOK GOOD, SAYS HORKHEIMER

Balboa President Is So Impressed with General Industrial Conditions That He Plans to Build Another Film Producing Plant and Organize Five New Studios for the Increased Demand for Pictures Bound to Follow the Upward Trend of Trade

Special to MOTION PICTURE NEWS

Long Branch, Cal., Nov. 2. **P**RAISING President Wilson's peace policies, declaring that European nations are placing unparalleled, record-breaking orders in the United States for supplies of all kinds and predicting that a golden era of prosperity is impending in North America, H. M. Horkheimer, president of the Balboa Amusement Producing Company of Long Beach, California, recently spoke of his investigations of business conditions in New York, Chicago, St. Louis and other cities during the last two months.

When he returned to the Long Beach studios of his company he announced that as a result of his highly successful trip to eastern localities the Balboa corporation would immediately complete plans to build another film producing plant in Long Beach, as a greater annex to its already large studios in this city and that five additionally new organizations of players would be formed within the next several months to produce the Balboa Feature Films.

"During my stay in New York," said President Horkheimer, "I found that all the large banking houses had an overabundance of money, in fact they are carrying from fifteen to fifty per cent of funds over the surplus necessary for them to have.

"While some people may believe that the banks' substantially solid conditions may be due to political reasons, I am still a very firm supporter of the present national administration, and I know that there are no reasons whatever for financial institutions to hoard up money, as some of them doubtless are doing.

"Tremendously large orders are coming to United States manufacturers from Europe for clothing, foods and ammunition—in fact, in every line of business. While I was in New York I met agents of European concerns who had commissions to buy everything from a clothes pin to a white elephant—and the foreign powers are paying the bills in gold.

Sees Era of Great Prosperity.

"I have always heard and read of the solidity of the Rock of Gibraltar—of its strength as a bulwark that could not be penetrated—and I know that the New York money market is equally impregnable. With the gold pouring into the United States business houses as it is at present, there is certainly coming the greatest era of prosperity the United States has ever known.

"Concerning the trend of the motion picture producing industry," continued Mr. Horkheimer, "I can say that the popular demand at present is apparently for the filming of famous books, celebrated stories, and time-tried successful plays.

"This demand is doubtless due to the fact that all the American film producers have raised the standard of excellence in their output. I believe, however, that just

as good pictures can be made out of new, original and novel themes as from the renowned narratives.

"As I understand the motion picture art it was first introduced for the amusement of the masses; i. e., the people of the universe. I therefore believe that we will always have with us the five-cent and the ten-cent theatre, and the owners of these popular-priced houses cannot, of course, afford to pay fancy prices for their films.

"Hence, there will always be a market for one-reel, two-reel and three-reel feature releases, for the amusement of the tired business man, or the person with a half-hour to spend in recreation and relaxation of the mind by going in to see a short and snappy photoplay. The great, long productions do not appeal to quick transients.

"The Great War has, of course, eliminated a number of the foreign selling fields of films.

"Americans now have the Australian, Canadian, Mexican and South American film fields all to themselves, with no competition from the former foreign producers. What we have had cut off in the continental selling fields has been about equally balanced by the additional new and exclusive markets in the countries I have named. The Australian field is now wonderfully large and profitable.

Censorship Plan

"In regard to municipal censorship of films the Chicago board continues to pursue its notably radical policy of rejecting and abridging releases. I believe that film producers should not stage pictures that are distasteful to the public generally. The best plan of censorship, however, would be, I believe, one which would afford a national committee of censors composed of representatives of all the largest cities—and this commission could view the films

and judge them properly. Motion pictures are a great deal in the same class with newspapers—and censor boards do not, of course, reject and abridge the news publications.

"Many gigantic organizations of capitalists have lately entered the motion film producing field, and this is due no doubt to the great amount of profit made in the industry, if a company succeeds. The film making game, however, is a millionaire's task.

"There have been many failures, because of limited capital, lack of stick-to-it-iveness, incompetent camera men and other shiftless workers who did not take the proper amount of interest in their employer's aims. Any educated man with capital could start in the film industry today and make money, but he would have to have a lot of original ideas, be willing to work hard and have with him a lot of honest and loyal employees.

"Slapstick comedy continues to maintain its hold on the amusement-loving public, especially the women and children. Refined slapstick comedy will always be a seller, but the refinement must be in it.

Thirty Balboa Prints a Week

"While some of the large American producers have recently raised the price of films, I do not contemplate elevating the rates for the Balboa output. The present returns we receive for Balboa films pay us a large profit on our investment.

"We have laid plans to have the Balboa studios release 6,000 feet of negative every week, with a minimum of thirty prints, which would be a total release each week of 180,000 feet of positive prints. We are also about ready to close a gigantic deal whereby we will have direct connections with one of the largest selling exchanges in the world."

Los Angeles Suburb Bars War Films

Rigid Censorship Exercised Over Photoplays, Photographs and Posters—Experiences of Exhibitors With the Police of Long Beach

Special to MOTION PICTURE NEWS

Los Angeles, Nov. 2.

WAR films—either genuine or made-to-order—are not to be shown at Long Beach, California, if exhibitors there follow the instructions given in a letter from the office of the chief of police. And furthermore, fire arms are not to be shown even in lithographs or photographs displayed in the lobbies of the theatre.

Exhibitors at Long Beach—which in Los Angeles is referred to as the home of the majority of the long-haired individuals—have been advised that pictures depicting war, preparations for war, or anything pertaining to war must not be projected. The order came following the showing of the Apex picture, *The Kaiser's Challenge*, *The Famous Battles of Napoleon*, and the Strand war pictures. Exhibitors have not

so far attempted to show pictures, and it is very probable that no attempt will be made to do so.

Lobby displays have been receiving careful censorship by the Long Beach police department. When "*War is Hell*," an Eclectic, was recently shown at the American Theatre, the police instructed Manager A. A. Frist to paste small pieces of paper over the pictures of guns and exploding bombs. Manager Martin of the Bijou had a similar experience when displaying paper for "*The Kaiser's Challenge*."

All of the motion picture theatres at Long Beach are located on The Pike, a street along the ocean front. According to reports business has not been good, and this in all probability, has caused the exhibitors to abide by the ruling of the Los Angeles police.

Cincinnati to Have All Feature Theatre

Strand, Modeled on New York House of Same Name, Ready December 1, First of Its Kind in City

Special to MOTION PICTURE NEWS

Cincinnati, O., Nov. 3.

AS the result of an elaborate theatrical deal involving several large film houses in Cincinnati, there will be established here the first large exclusive picture feature theatre in the city. On December 1 the Gayety theatre, which has been devoted to burlesque, will be operated by the Strand Amusement company and will be known as the Strand theatre.

The company was recently incorporated for \$25,000 by B. L. Heidingsfeld, I. Libson and E. J. Babbit.

It will be modeled after the Strand theatre in New York. The B. F. Keith interests, it is understood, are backing the project. Until two years ago features in motion pictures were unknown in Cincinnati. At that time Clay Brehm, now manager of the World's Special Feature Corporation in this city, induced Charles Weigel, manager of the Alhambra to try a feature in which Brehm appeared as one

of the characters and scored a real hit.

Weigel has been showing features ever since and they have gained a strong foothold in the city. Weigel is now showing features exclusively, as is J. J. Hennegan of the Lubin and a number of other houses.

I. Libson, one of the incorporators of the company, is at present the manager of the Family theatre, one of the most successful motion picture theatres in the city. He has been showing there a high class three-reel program. Last summer he tried features at the Grand theatre and was successful with them.

The Gayety last summer was also used for features but did not make money, and Tom Corby, who was in charge at the time, was forced to close up after a few weeks.

Sentiment in favor of features is being felt throughout the city according to film men and it is expected that the new feature house will be successful from the start.

Frisco Plans Uniform Convention Rates

Hotel Men Agree to Prevent Exorbitant Room Rent as Inducement to Bring National Gathering to City Next Year

Special to MOTION PICTURE NEWS

San Francisco, Nov. 2.

AT the recent state convention of motion picture exhibitors held at San Francisco a committee was appointed to investigate hotel rates and details connected with the proposed holding of the national convention in this city in 1915. The chances of this city being selected as the meeting place depend largely upon the accommodations that could be secured.

It will be interesting for the trade throughout the country to learn of the extensive plans that have been made by local hotel owners to accommodate visitors in 1915 and to prevent raising of rates. The hotel men of this city have formed the San Francisco Hotel Bureau,

with a membership of about four hundred hotels and apartment houses, representing almost seventy-five thousand rooms.

Rates have been established at from one dollar to three dollars a person, European plan, and from \$3.50 a day and up, American plan. The bureau will guarantee reservations made at the specified rates and has posted a large forfeit with a trust company to insure perfectly fair play.

An official tabulation of the accommodations to be found here shows that there are over 2,200 hotels, apartment houses and rooming places, with a total of about 120,000 rooms, with a large number in course of construction.

M. L. LANGHORST.

William Kessel, Pioneer Film Man Dead

New York Motion Executive, the Second of the Kessel Brothers to Pass Away in Six Months, Well Known in Industry

WILLIAM KESSEL, a pioneer film man and brother of Adam and Charles Kessel, of the New York Motion Picture Corporation, died suddenly Friday, October 30, at 10 a. m. at his home, 179 Decatur street, Brooklyn, N. Y.

Mr. Kessel was very well known in the manufacturing end of the film industry, at different times being a manufacturer, state rights buyer, exchange manager and exhibitor. In fact, he has been everything in the motion picture business but a director. At the time of his death he was doing confidential work for the New York Motion Picture Corporation.

It was the late William Kessel's report on European affairs which guided the

New York Motion Picture Corporation in its foreign policies. Mr. Kessel only recently returned from Europe after an extended tour.

This is the second of the Kessel brothers to die in the past six months.

SAN FRANCISCO COMPANY FORMED

Special to MOTION PICTURE NEWS

San Francisco, Nov. 2.

Articles of incorporation have been filed at San Francisco of the Randolph Feature Film Company, the capital stock being \$200,000. Those interested in the new enterprise are F. W. Randolph, A. Gale, O. E. Coom, F. A. Wilhelm and J. Gale.

LASKY PRIZE WINNER BEGINS COURSE OF STUDY

A new and wonderful future opened before little Blanche Austin of Dayton, O., who arrived in New York recently to begin a course of instructions under David



BLANCHE AUSTIN

Belasco, preparatory to becoming a member of the photoplay stock company of the Jesse L. Lasky Feature Play Company at Hollywood, Cal.

The arrival of Miss Austin in New York, is the last whispering recollection of the exhibitors' convention at Dayton, Ohio, during which time the Dayton Herald, through arrangement with Samuel Goldfish, conducted a beauty contest, the winner of which was to be given an engagement at the Lasky studios.

Miss Austin was successful in competition with twelve hundred other Dayton girls, and will begin her instructions next week under Mr. Belasco, with whom she will spend one hour a day. Miss Austin is but seventeen years of age, frail and with features that should register sympathetically upon the screen.

General Manager Samuel Goldfish of the Lasky organization selected Mary Charleson as chaperone for Miss Austin during her month's stay here, and Miss Charleson has mapped out an excellent program of entertainments. Miss Austin will probably make her first performance in one of the Lasky-Belasco productions, early in December.

NO MORE MERRY ROAD LIFE FOR COOK

Special to MOTION PICTURE NEWS

Milwaukee, Wis., Nov. 4.

Frank Cook, who so successfully pushed "The Spoilers" during the past few months, has grown tired of the road, with its sleeping cars and hotels and has returned to Saxe Brothers, being in charge of their Princess Theatre.

"I have had too many years of tramping," said Mr. Cook, "to go back to the road at this day in my life so that when a position that would keep me at home offered itself you can believe I jumped at it."

LIVE WIRE EXHIBITORS

EDITOR'S NOTE.—It is the desire of "Motion Picture News" to include under this heading novel advertising ideas, successful schemes in the management, decoration and equipment of the theatre—everything, in fact, done by the exhibitor to stimulate his trade. We invite every exhibitor to write us about any new enterprise he has; also to come to us for advice or information along any line. Address: Editor, "Motion Picture News," 220 West Forty-second Street, New York City

COURTESIES THAT COUNT

"THE patrons of this theatre are your real employers, and they pay your salary. Treat each customer just as though he personally handed you your check each week."

This is a part of the general instructions that all employees receive on entering the service of the New Lake Theatre, Nicollet avenue and Lake street, Minneapolis, and the patrons are treated just that way.

The employees are also told that the motion picture business is largely personal and neighborly, and that the employees should know the patrons and learn their likes and dislikes.

When one stands at the entrance of the New Lake any night after 7 o'clock, waiting for a chance to get in, he will hear the door man and the ushers arranging to care for the persons in line.

"Mr. Jones is here with his family and he wants to sit well back," one of the ushers will say to another.

Mr. Jones hasn't the best eyes in the world and he must sit back to enjoy the film. Smith may be near sighted. The door man knows he is waiting, and the door man has learned it by talking with him while he has waited in line.

Some can't stand draughts and some are fresh air fiends. There is a place for them

all, and the ushers try to get acquainted and learn these things while the house is crowded and no one is passing out.

This policy, carried out with the greatest care, explains in part why the firm of Green and Agnew have got to build a new theatre. The recent one, the largest in the residence district and less than two years old, is far too small, and plans for the new place or a general makeover are being discussed.

The good part of this policy is, according to the proprietors, that the employees like it just as well as the patrons.

MAKING ONE'S OWN LOBBY SIGNS

COMBINING his ability as an artist and sign writer with his duties as manager of the Victoria theatre, 220 West Fifth street, Cincinnati, Clarence McCormick has inaugurated a unique advertising campaign for his picture house.

In addition to his posters displayed in the lobby frames, Mr. McCormick advertises each new feature with huge signs, suspended across the front of his lobby. These signs he writes himself. Their attractiveness is added to by the fact that the signs are embellished with original illustrations, Mr. McCormick's own handiwork.

Recently he featured a Ford Sterling

comedy. The sign was three feet wide and over six feet long. In the center was a picture of Sterling in one of his characteristic attitudes. Patrons of the Victoria have come to regard McCormick's signs as part of their entertainment and they have received a great deal of favorable comment.

GENEROSITY THAT PAYS DIVIDENDS

A NOTABLE piece of enterprise—it is enterprise, though the motive behind it is broader than that in its scope—originated in the mind of Walter H. Golding, manager of the Imperial Theatre, King Square, St. John, N. B., and is now a temporary feature of the house policy.

MOTION PICTURE NEWS' readers, to grasp fully the significance of the idea, must realize that we are living in war times, and that Canada, as well as England, is at war. St. John has sent some five hundred or more men to the front, and it is their going that gave Mr. Golding the idea, and won him new friends for the Imperial.

Figuring that many of those who went from here to fight England's battles were in but ordinary circumstances, and left little behind them to keep wife and kiddies in comfort and necessities, and realizing what the "movies" have come to be in the life of those whose amusements must of necessity be low-priced, he has thrown open the doors of the Imperial to the wives and families of the St. John soldiers who have gone to the battlefield. This means something directly cut off from the theatre's nightly receipts, but there is a fine spirit back of the move, and there is popular acclaim for this thoughtful course.

The Imperial will stand higher than ever in popularity and, though this was not what dictated the plan, there is little doubt that good results will accrue to the theatre, apart from the satisfaction of doing a kindly act.

Special non-transferable tickets have been prepared and are issued on proper credentials being presented. They are good while the war lasts. If this is not getting increased business at the moment, it is popularizing the Imperial anew.

A 1,200 WEEKLY INCREASE WITH MAILING LISTS

R. C. ROGERS, press agent of the Walnut Theatre, Louisville, Ky., has been trying out an advertising campaign which has proven very successful in getting the public acquainted with the film attractions this house offers.



LILLIE LESLIE IN "MARAH THE PYTHONESS" (Lubin)

Several weeks ago Mr. Rogers secured mailing lists of customers of department stores and sent out letters to these persons, inclosing a pass for two, and inviting them to be the guest of the management on a certain night.

The first week 6,000 letters were sent out and returns were received from about 3,400. The following week the paid admissions at this house increased 1,200.

Every week since, the actual paid admissions have increased, according to Mr. Rogers, who says that he regards this as a highly successful method for getting the public acquainted with the quality of entertainment provided and securing a resultant steady patronage for a theatre.

The Walnut Theatre has a large seating capacity, and experimented on a large scale, but it is the opinion of the management that a smaller house, trying out the same plan on a smaller scale, would get good results.

A LIVE WIRE IN CALGARY

UNIQUE business getting methods adopted by Manager Aylesworth, of the Princess theatre in Calgary, Alberta, have made this theatre one of the most popular in the city. The Princess is the latest picture house built in Calgary, and in addition to the showing of movies it is equipped with a stage which enables the management to have a series of vaudeville acts at each show.

The latest business boosting schemes adopted by Manager Aylesworth is a "country store" night and a "baby contest." Both these have been big attractions and are proving to be real business getters. The baby contest, which is run by means of votes, has also proved a big business booster.

Another weekly feature at the Princess theatre is a newsboys' pie eating contest. This night is looked upon by patrons as a real "laugh" night. Several big, juicy pies made up with fresh blueberries or strawberries, or whatever fruits are in season are given to the boys, and the result is a scream. A shoe-lacing contest has also been put on at this house with as good success, and these novel business getters are proving to be very popular with Princess patrons. Other similar schemes are being devised.

STRENGTHENING WEAK NIGHTS

JOSEPH GREEN of the Wigwam Theatre, has adopted a novel idea for equalizing the attendance at his theatre through the week and building up the "light" nights wherever possible.

He has had printed strips of tickets, seven ten cent tickets for 50 cents, and seven five cent tickets for 25 cents. Each ticket is good only on a certain day of the week. So that the purchaser must see a show each day of the week to get his money's worth.

The first ticket reads, "good any Monday night," the second, "good any Tuesday night," etc.

The ten cent tickets are printed on blue stock and the five cent tickets on yellow stock to distinguish them from the regular tickets.

Shep, Sheep Dog, Some Actor, Cleared of Crime

Thanouser Star, a Gentlemanly Canine, Temporarily Under a Cloud Through a Grievous Mistake, Regains His Prestige by Picture Comparison

"SHEP," the famous dog actor of the Thanouser studio has come under the eye of the police—and Chicago at that. "Shep" has committed no crime for which a dog of his theatrical standing might be held accountable. He is merely the victim of mistaken identity. The following letter from William H. Luthardt, secretary to

used in one of your films. She feels almost certain that it is her dog Shep. I enclose herewith a photograph of the dog lost by her and will appreciate it very much if you will kindly advise me how long your company has had the dog "Shep," used in your pictures. A description of your dog, how long you have had it, and



SCENE FROM "SHEP'S RACE WITH DEATH" (Thanouser-Mutual)

the Chief of Police of Chicago, was what brought "Shep" before the Thanouser managers for investigation.

"The Mother Superior of a certain convent in this city lost a dog some time ago, and recently she saw the picture of a dog

any additional facts, that may convince her as to the animal's identity."

A comparison of pictures showed a striking similarity. However, in behalf of "Shep" a plea of not guilty was entered and his acquittal is looked for.

Combine to Wage War on Legalized Censorship

Managers Protective Association Joins Hands With National Board of Censorship in Strong Campaign Against Political Supervision of Films

AN important step in the fight against legalized censorship in any form, local, State or Federal, waged by the national board, has been taken in the union of forces between the National Board of Censorship and the United Managers' Protective Association, an influential body whose membership includes at the present time the managers of more than 2,700 theatres.

According to the terms agreed upon at the meeting of representatives of both organizations in the office of J. W. Binder, director of publicity for the National Board of Censorship, last week, the United Managers' Protective Association will cooperate in all manner possible for the purpose of freeing exhibitors and film manufacturers from the trammels of political bodies in the exercise of undesirable censorship.

The United Managers' Protective Association has also agreed to subordinate its efforts in this direction by leaving the plan of campaign to the discretion of the National Board of Censorship. The managers'

organization has promised hearty co-operation along lines peculiarly its own in the fight against statutory censorship conducted by the national board.

The understanding between the two organizations brought about at the conference in the office of Mr. Binder followed the resolution adopted by the board of governors of the United Managers' Protective Association at a recent meeting of the managers' association.

The officers of the United Managers' Association are: President, Marc Klaw; vice-president, Lee Shubert; second vice-president, E. F. Albee; third vice-president, H. W. Savage; fourth vice-president, Sigmund Lubin; treasurer, Sam A. Scribner, and secretary, Charles A. Bird.

The executive committee consists of A. L. Erlanger, Wm. A. Brady, Alf. Hayman, E. F. Albee, Walter Vincent.

On the executive committee (motion pictures) are J. Stuart Blackton, Carl Laemmle, Samuel Long, Adolph Zukor and P. A. Powers.

AMONG THE EXCHANGES

CASINO GETS ALLIANCE AND SAWYER

THE Casino Feature Film Company, Detroit, has added the Alliance Program and the Big Features of the Sawyer Corporation. Harry Goldberg, sales manager of the company, states that he is now supplying films to over 125 theatres in Michigan alone, and that there is hardly a new theatre going up that has not applied to the Casino company for service.

"Our business is forging ahead beyond all expectations. In the past few weeks we have been forced to turn down six big houses because our service had been previously contracted for by other houses in their territory. And in this connection, I want to say that there is one thing we aim to do and that is to take care of our old customers as long as they care to stay with us and give us the same square treatment as we try to give them.

"The Casino company is now releasing each week two Paramount features, one Alliance, one "big" Sawyer and one Apex.

PRELLER GOES TO WORLD FILM

WILLIAM C. PRELLER is now the manager of the Minneapolis office of the World Film Corporation. Mr. Preller has been the manager of the feature department of the General Film Company, in Minneapolis, and he has also managed the Eclectic Film branch in that city. J. M. Kuhn, who has been the manager of the Minneapolis office of the World Film Corporation, has been made special representative for the Minneapolis district.

N. H. Spitzer, manager of the Kansas City branch of the World Film Corporation, was called to New York on account of the death of his mother, spending three days in the city.

ALCO, LOS ANGELES, OPENS

THE Alco Film Exchanges was opened in Los Angeles, Monday, November 2, in charge of E. H. Emmick, who has been manager of Sol Lesser's Golden Gate Film Exchange in this city. This will have exclusive control of all Alco releases—which includes the All Star Corporation's products—for California, Arizona and Nevada.

Elegant furniture has been made for the offices, and the exchange has class A equipment throughout.

In addition to managing the new exchange Mr. Emmick will also continue to supervise the Golden Gate Film Exchange, which will continue at the present location.

A WELCOME ARRIVAL

THERE is a new film man on the West Coast. He weighs nine pounds, and is the son of Ernest Bru, Los Angeles manager of the Apex service.

EXCHANGE MEN REPORT BIG "AFTER THE BALL" BOOKINGS

"AFTER THE BALL," the Photo Drama Company's production, is setting a pace.

Al Cross, of Pittsburgh, reports the highest rentals ever paid in his city. A. Seigel, of Cleveland, has three copies booked solid. Sam Cohn, at Philadelphia, is doing a land office business with two prints. Arthur Langan, at Toronto, Canada, is booked solid in high class theatres from Montreal to Toronto. E. A. Westcott, of Rochester, New York, has two prints working every day.

Sam Silberman, at Milwaukee, Wisconsin,



AN "AFTER THE BALL" CROWD IN MILWAUKEE

sin, has booked every high class house in Wisconsin and Minnesota. Frank Dikehouse, now playing the picture at the Mary Anderson Theatre, Louisville, Ky., reports numerous bookings, coming in for that territory. J. Abrams, at Dallas, Texas, says: "Send two more prints." F. Duryea is working over-time out of New Orleans, La.

Geronimo Film Company, of Stamford, Conn., has the state covered, while the Photo-Play Productions Releasing Company, of Chicago, report the greatest ever. This is the second winner within a year, produced by the Photo Drama Company, under Pierce Kingsley's direction. With the above fleet of sure-to-goodness film men, and Bill Steiner and Jim Maher handling the local bookings from the New York office. It sounds like real success.

SCATES IS DIVISION MANAGER

W. R. SCATES is now division manager of the World Film Corporation with headquarters in Chicago. Mr. Scates' territory gives him supervision over the following branch offices: Cleveland, Cincinnati, Detroit, Indianapolis, Chicago, Minneapolis, Omaha, Kansas City and St. Louis. Mr. Scates has been associated with Louis.

NEW BRANCH MANAGER FOR ECLECTIC

EDWARD AUGER, one of the best known film men in the business, has been appointed manager of branches for the Eclectic Film Company, vice Arthur S. Kane, who has resigned.

Over ten years ago Auger became interested in the motion picture business and soon graduated from the ranks of the exhibitors into the exchange end, becoming general manager of the Ouimetoscope Film Exchange in Montreal. An engagement with the Kinetograph in Canada followed during which he traveled from New Brunswick to British Columbia.

The General Film Company then offered him the managership of their St. Louis branch, which he accepted and held for a number of years. When the Eclectic Film Company started opening up their own exchanges Mr. Auger was tendered the position of inspector of branches, which position he held up to the moment of his promotion.

Few men in the film business are as well known as Mr. Auger. From coast to coast and from Winnipeg to New Orleans his acquaintances and friends are legion. Their good wishes follow the big man with the smiling face as he takes up his new duties.

SCENICS BECOMING VERY POPULAR

THE "See America first movement" has been keenly felt at Milwaukee film exchanges and they all report a very surprising and unusual demand for scenics of America and its possessions. Where pictures of this sort were pretty much a drug on the market four weeks ago they are today as difficult to secure as good comedies, in fact more so, as the supply of them is not over adequate.

"The demand for scenics has been unusually large in the past few weeks," said J. R. Freuler, vice-president of the Mutual Film Company, and head of the Western Film Exchange of this city. "The only way I can account for it is that the 'See America first' talk which is sweeping the country since the European war broke out is getting the people interested in our country, and that the demand for the scenic pictures is but a forerunner to a wholesale western emigration of tourists next summer."

AIKEN WINDS UP COAST TRIP

F. C. AIKEN, the special representative for the General Film Company, with headquarters in Chicago, visited the Butte, Montana, theatres recently. He has been on the coast for the past three months calling on the various theatres that are running his company's releases.

He says that the moving picture business is in better condition than any other business he is aware of.

WATCH ACCESSORY NEWS

Pages 69 to 82

WARNER'S, ST. LOUIS, MOVES

WARNER'S Features, St. Louis, have moved from their quarters in the Benoist Building at Ninth and Pine streets, to a handsome suite of offices on the ground floor of the Polar Wave Building in the 3600 block on Olive street. This block has earned the right to be known as Exchange Row, since three of the largest exchanges for the distribution of moving picture films in St. Louis are located there. Warner's Features new offices are midway between the General Film Company's exchange, which occupies the building at 3610, and the Box Office Attractions exchange, which is at 3632, same block.

FARRELL FINISHES TOUR OF MAINE

E. J. FARRELL, manager of the Boston Exchange General Film Company, has just returned from a trip through Maine. He spent a part of the time at the Bangor office and visited with Mr. Cudday, Augusta Opera House; Mr. Kelliher, Waterville Opera House, and in Lewiston, Maine, with W. P. Gray.

J. A. Eslow, manager of the Universal Exchange, visited Mr. Gray for a week end.

PICTURE PLAYHOUSE OPENS DALLAS OFFICE

THE Picture Playhouse Film Company has opened a new office, located at 202 Andrews Building, Dallas, Texas, and has installed P. A. Block as manager.

William J. Lee, general manager of exchanges, has spent some time in Dallas arranging for the opening of this office and has already received a number of advance bookings on the releases.

HALLETT SUCCEEDS McNEILL IN MUTUAL

G. J. HALLETT, formerly associated with the General and more recently with the Universal company in New York City, has just assumed management of the Mutual's branch exchange, 15 North Fifth street, Harrisburg, Pa. He succeeds Garfield McNeill.

CASINO COMPANIES ADD NEW QUARTERS

THE Casino Feature Film Company, and the Casino Amusement Company, occupying offices 2206-2211 Dime Bank building, Detroit, are finding it necessary to enlarge, so have added offices No. 2205 and No. 2212, giving them a total of eight rooms.

WORLD OPENS EXCHANGE IN OMAHA

THE World Film Corporation has opened its twenty-seventh branch office, at Omaha, Nebraska. D. R. Pearsons has been placed in charge of the Omaha branch. Mr. Pearsons has been the Omaha manager of the Eclectic Film Company and the General Film Company.



SCENE FROM "THE SPIRIT OF THE POPPY"
(Kinetophote Corporation—Six Reels)

New Orleans Local Color for "Springtime"

Thirty Life Photo Players Go to Crescent City, Where Many Structures of the Period in Which the Play Is Laid Will Be Filmed

EDWARD M. ROSKAM, president of the Life Photo Film Corporation, which has just concluded arrangements to release through Alco, starts on Monday in a special car with a company of thirty for New Orleans. The object of the trip is to make the picturization of "Springtime" in five parts in the scenes of the Booth Tarkington drama, the first release Life Photo will make through Alco.

The company is headed by Florence Nash, who stars in "Springtime." In the support of Miss Nash are Adele Ray, William H. Tooker, E. F. Roseman, Bert Gardner, Mrs. Sue Balfour, Frank Holland, E. F. Flannigan, Charles Travis, Warner P. Richmond, and others.

"Springtime," it will be remembered, is a story of the war of 1812, laid in and about New Orleans. Many of the structures mentioned in this former hit of the legitimate stage are still standing. Mr. Roskam, who has undertaken the general direction of that production and of the party, has determined to have as many of the scenes as possible enacted before the camera in their original locations.

He plans to spend at least four weeks in New Orleans and the vicinity in this work. One of the undertakings of the company to which actors and actresses are looking forward to with pleasure, is the picturing of the old French quarter of New Orleans.

Some of the interiors will be photographed in houses which date back to French days in New Orleans. Where this is found not to be practicable, studio work will be done. In order to have the proper atmosphere, properties and studio settings, Mr. Roskam is carrying with him to New Orleans fifteen sets of scenery and considerable properties.

The costumes have been designed by artists who are thoroughly familiar with Colonial modes. The costumes of Miss Nash, who plays Madeline are especially attractive and suit her dainty personality thoroughly.

The scenario for "Springtime" has been prepared under the personal direction of Mr. Roskam. He has been aided by a number of producers. He believes that he and they have given the public the best there is in them.

Through the story of "Springtime," in an incidental way, runs the theme of battles. These are not, however, more than a strenuous accompaniment to the dainty story. And so they will be treated in the picturization. No big battles will be shown, but flashes of skirmishes, as it is felt by the Life-Photo producers that big war scenes would detract from the effect of the story.

The camera work will be done under the direction of John C. Arnold, well-known in the trade. The director for "Springtime" is William S. Davis, producer of many high class picture productions.

TWENTIETH EPISODE TO END "PAULINE"

In response to many requests received by the Eclectic Film Company as to the probable duration of "The Perils of Pauline," public announcement is made that the big serial will be completed with the twentieth episode. As the seventeenth episode will soon be released this means that there will be but three more made.

"The Perils of Pauline" has been extraordinarily successful, and the demand for it is holding strong to the very end.

Looking Ahead With The Producers

\$18,000 LABORATORY SCENE IN "ZUDORA"

AN entire circus outfit, horses, wagons, tight-ropes, and tents were used in the first episode of "Zudora," Thanhouser's forthcoming serial. The wagons loaded with the impedimenta of the road circus, the pulling and hauling of "props," the tight rope stretched across the ring, all were in place. Even the side show barkers, busy with their "bally hooing," had their place in the scene, which on the screen is cut almost to a flash.

Laboratory appurtenances valued at \$18,000 were used in one scene of "The Mystery of the Frozen Laugh," the second episode of "Zudora," Thanhouser's big serial which has its first release November 23.

The scenario, created by Dr. Daniel Carson Goodman, demanded a complete equipment. It was necessary to lay an entirely

"Little Lord Fauntleroy" Released Through Alco

THE Alco Film Corporation announces that its next release, that of November 16, will be Mrs. Frances Hodgson Burnett's story of child life, "Little Lord Fauntleroy." The story was published in 1888 and

Leslie were among the popular Fauntleroy's.

So it may be imagined that with all these elements in its favor the picturization of "Little Lord Fauntleroy" will become the fashion.

The cast which played "Little Lord Fauntleroy" before the camera is headed by Master Gerald Royston as little Lord Fauntleroy. The Earl of Dorincourt is played by H. Agar Lyons, Dearest by Jane Wells, the Adventuress by Miss V. Osmond, Silas Hobbs by F. Tomkins. The butler is John East and Higgins, the tenant farmer, is Jack Denton.

The picturization is in a prologue and three reels. The prologue deals with matter which in the book and stage version was only suggested. In the vivid way of the screen something of the lives and fate of the two elder sons of the Earl is shown,



"THE LITTLE LORD" HOLDING COURT

created gradually an impression which deepened until it became a furore.

So strong was the effect made that it even influenced the style of little boy's dress. To their intense discomfort a whole generation of small boys was dressed in peculiar knickerbockers, sashes and coats. Many children were taught to call their mothers "Dearest." In fact, in the late '80's two types of boys began to develop. Those who affected the Lord Fauntleroy modes and those who threw dirt upon the first class.

But aside from all its frivolous effects, "Little Lord Fauntleroy" is one of the modern classics of the English tongue. Its theme of mother love, boy's devotion to a mother and a certain idealism of youth, struck a response in not only the United States, but in England and other lands.

The vogue of the story speedily spread to the stage. At one time there were some twelve Fauntleroy companies touring the country or playing long engagements in the large cities. Various infant prodigies on the stage had their rise in "Little Lord Fauntleroy." "Tommy" Russell and Elsie



AT HOME

There is a particularly strong series of scenes at the English race course showing how Bevis bet away his patrimony and how his life came to an end when he was hurled from a horse. The death of Maurice, the second son, in Italy, is pictured, too, in a pathetic manner.

The prologue shows as well the fate of Captain Cedric Errol, the father of Little Lord Fauntleroy. The three reels of the story proper follow closely Mrs. Burnett's development of her theme.



THE HYPNOTIZED BURNS CONFESSES

(Zudora-Thanhouser Serial)

new floor in the west studio of the Thanhouser New Rochelle group to permit the installation of heavy tanks of liquid air. This is the first time that the tremendous power of liquid air has been demonstrated on the screen.

Indications are that the bookings on "Zudora" will exceed the record interest manifested by the exhibitors in "The Million Dollar Mystery." These exhibitors who filled their houses during the summer with the Lonergan serial are anxious to get booked up on this latest of big serials. The inquiries being received are very flattering to the Thanhouser management and demonstrate the power of their serials.

Blackwell Filming Second Davis Story

WITH "The Man Who Could Not Lose" shipped east to the Alliance Films Corporation, Carlyle Blackwell, of the Favorite Players' is starting on a five-reel production, another of Richard Harding Davis' stories, entitled "The Last Chapter." The story as originally written is called "An Unfinished Story," but this title has been changed to more suitably fit the photoplay, and the new name is an apt one. In "The Last Chapter" Carlyle Blackwell has a role which calls for emotion, and which is strongly dramatic; in fact, as powerful a

role as he has ever undertaken. The psychological interest running through the theme makes splendid character studies for the members of the cast. The story takes the action into the heart of Africa, as well as into American and English society. Some wonderful scenic effects are being studied out.

Carlyle Blackwell, of the Favorite Players, gave a private showing of "The Man Who Could Not Lose," a story by Richard Harding Davis, to a few friends and some members of the trade a few nights ago, and

the expressions of approval were numerous. The locations selected for the exterior scenes are beautiful in the extreme, and the interiors are especially rich and pleasing to the eye.

Another promising success following that of "The Path Forbidden," which was presented by the Excelsior Feature Film Company, will be "When Fate Leads Trump," a four-reel production, from the book by John B. Hymer, featuring Octavia Handworth in the title role. The plot takes one into the rustic life of the mountains, and the interior scenes are well appointed. In endeavoring to make clean, pleasing features for moving picture enthusiasts, the Excelsior Company have succeeded with their second release.

TRIO OF FEATURES FROM KINETO- TOPHOTE

The Kinetophote is announcing a trio of releases for this month and is featuring a long list of stars who are well known both in the film world and to theatre goers.

A big success is predicted by the Kinetophote for "The Spirit of the Poppy," by Catherine Carr. In this production Edward Mackay, present chief director for the Kinetophote; Edith Luckett, leading woman with Chauncey Olcott; Anna Rose, a favorite on the French and American stage; Nicholas Dunaew, a Russian actor known to all filmdom; and William Dunn, famous in heavy "movie" leads, are among those featured.

"The Span of Life," the second of the big Kinetophote releases for the month is none other than the late Sutton Vane's famous old melodrama of the same name, which has been picturized by Catherine Carr. Lionel Barrymore is being starred in the piece as Richard Blunt. Gladys Wynne has the role of Kate Heathcote and Lyster Chambers is the heavy.

The part of the little cripple is taken by Ogden Childs, a well known child actor. The famed scene in which the acrobats make a human span of their bodies so that the heroine may escape to safety across a deep chasm has been done with strict attention to detail.

In "The Coming Power," a story of political intrigue and retribution by Catherine Carr from the story of Walba Waldo, the Kinetophote has chosen a goodly list of stars who are known everywhere. Lionel Adams, who is now playing in "Kick In," and was starred in "The Man of the Hour," is the young radical of the film story.

Edith Luckett has the part of the girl who is the inspiration of the young candidate and Anna Rose is the daughter of an ex-judge and political henchman. William Crimmins, a Belasco player and recently featured in "At Bay," has the part of the wealthy power in politics, known as "The Vulture." "The Coming Power" is in four parts and is about ready for release. The picture was made under the direction of Edward Mackay.

Cabiria Soon Available For All Exhibitors

Itala Company Plans to Place the Big Spectacle Within Reach of Every Motion Picture Theatre—The Picture's Record

"CABIRIA" is soon to be offered to the regular motion picture theatres, according to the rumor confirmed this week by Harry R. Raver, who is exploiting the Itala super-spectacle throughout the United States and Canada.

This announcement seems likely to cause a flurry among exhibitors who realize what prestige the presentation of "Cabiria" in their theatres will mean, after the advertising the photo-play has received and because of the fact that it has been played at leading theatres in almost every American city at prices of admission ranging from twenty-five cents to two dollars. Thus, the Itala company believes it is logical to state that any exhibitor booking "Cabiria" advertises his theatre as a theatre which dares to book the best, well aware that the prestige accruing therefrom will mean many dollars to him in days to quickly follow, and quite worth while the ignoring of big profits from the immediate booking.

Since July, beginning at the worst season and pulling capacity houses at that, fifteen companies, equipped with orchestras, choruses, musical directors, managers, advance agents, operators and complete stage decorations have been operating from coast to coast.

For six consecutive months "Cabiria" has been running on Broadway in New York, and to-day the house is still packed as it was in the run's infancy.

Significant of the compelling interest of the film, it is estimated that out of the six hundred thousand paid admissions in New York, twenty-five per cent of the spectators saw the production two and three times.

Chicago five months, San Francisco nine weeks, Philadelphia six weeks, Atlantic City two months, and other cities from four to ten weeks is the record of "Cabiria." In each city it was presented with all the dignity of a grand opera performance, the production appearing in none other than the finest legitimate theatres.

Famous Actress In "Hearts and Flowers"

Mrs. Thomas Whiffen, Whose Stage Career Dates Back to 1869, Will Have Leading Role in Cosmos Feature

WHEN the Cosmos Feature Film Corporation release the five part photo-play "Hearts and Flowers," there will, undoubtedly, be many who would like to know more concerning that delightful old lady, Mrs. Thomas Whiffen, who plays the leading role. To those this brief resume is respectfully dedicated.

For forty-six years Mrs. Thomas Whiffen has been on the stage, and most of those years have been devoted to playing old lady parts in conjunction with some of the best known stars in this country. In 1869 Mrs. Whiffen came to America from England and early resolved to make a specialty of old lady parts. She had the distinction of playing "Buttercup" in the original production of Gilbert & Sullivan's "Pinafore" in the old Duff Opera Company in New York.

Later, she appeared in the famous Hazel Kirke production, when that play ran for

486 nights in New York; in this production Mrs. Whiffen played Mercy Kirke, the wife. She was also associated with the Madison Square Company; in association with E. M. Holland, Jeffries Lewis, Eben Plimpton, George Payvan, Herbert Kelcey and other players of equal note.

Next Mrs. Whiffen joined the Lyceum Company, which will be remembered by many Chicago theatre goers, playing the part of the blind mother in "The Charity Ball," in which she created one of her best roles. As Mrs. Talcott, an elderly companion and chaperon, with Ethel Barrymore in "Tante," Mrs. Whiffen proved a delight beyond words.

At the present writing Mrs. Whiffen is delighting audiences at the Lyceum Theatre, portraying the part of Mme. De Trevillac, Helen's grandmother in "The Beautiful Adventure," a new comedy in three acts.

Pearce Starts On Tour of Principal Cities

Special Eastern Representative of Bosworth Will Act as Ambassador to the Newspapers in Behalf of Motion Pictures

CARL H. PEARCE, special Eastern representative of Bosworth, Inc., recently started on an extensive trip to investigate the various exchanges in the big cities, handling the productions manufactured by his company.

The mission of Mr. Pearce, who is probably one of the most progressive men in the film industry, judging from the live wire methods he constantly introduces to facilitate the distribution of the products of Bosworth, has been undertaken for the purpose of studying conditions with particular reference to signs of hostility toward motion pictures.

Mr. Pearce intends to make himself

known to the various newspapers and expects to establish an entente cordiale.

Among the various cities visited by Mr. Pearce will be Pittsburgh, Chicago, Minneapolis, St. Louis, New Orleans and Dallas. Boston will be the first stop of the Bosworth special representative.

BAMBERGER TO INDIANAPOLIS

LEON BAMBERGER, who has been doing special work for the Buffalo branch of the World Film Corporation, has been transferred to the Indianapolis office, to do similar work in connection with that branch.

Motion Picture News

HAS THE QUALITY CIRCULATION OF THE TRADE

MOVING PICTURE NEWS EXHIBITORS' TIMES

Published Every Week by

EXHIBITORS' TIMES, Inc.

220 West 42nd Street, New York City.

TELEPHONE BRYANT 7650

Chicago Office, 604 Schiller Building

WILLIAM A. JOHNSTON.....	President
HENRY F. SEWALL.....	Vice-President
E. KENDALL GILLETT.....	Secretary
H. ASHTON WYCKOFF.....	Treasurer
WENTWORTH TUCKER.....	Ass't Treasurer.

WILLIAM A. JOHNSTON.....	Editor
LESLEY MASON.....	Managing Editor
WILLIAM RESSMAN ANDREWS.....	News Editor
H. ASHTON WYCKOFF.....	Business Manager
R. M. VANDIVERT.....	Advertising Manager
E. J. HUDSON.....	Circulation Manager
THEODORE S. MEAD.....	Chicago Manager

This publication is owned and published by Exhibitors' Times, incorporated under the laws of the State of New York. The offices and principal place of business are at 220 West 42nd Street, New York City. The address of the officers is the office of the publication.

Entered as Second-Class matter at the New York Post-Office.

Subscription \$2.00 per year, postpaid in the United States, Mexico, Hawaii, Porto Rico and the Philippine Islands. Canada, \$3.00; Foreign \$4.00 per year.

ADVERTISING RATES ON APPLICATION.

Copy for next issue must reach us by Tuesday, 5 p. m.



Cuts and copy are received subject to the approval of the publishers and advertisements are inserted absolutely without condition expressed or implied as to what appears in the text portion of the paper.

Vol. X November 14, 1914 No. 19

The Peril of the Photoplay Industry

PROBABLY no single literary or dramatic work of the last hundred years exerted the widespread, irresistible moral influence that "Uncle Tom's Cabin" did. Its effect on public opinion just before the Civil War is a matter of history.

That it brought the horror, suffering and degradation of human slavery with terrifying clearness before tens and hundreds of thousands of Americans is common knowledge.

That the influence of Harriet Beecher Stowe's novel was in any instance anything but educational and uplifting no one would for a moment assert.

* * *

AND YET— The theme of "Uncle Tom's Cabin," the material of which the story is made, could have been treated in such a manner as to make it as revolting, suggestive and depraved a book as was ever confiscated by the United States postal authorities.

Instead of making abolitionists, it might just as easily, in other hands, have been designed to breed Simon Legrees.

Instead of being the most damning indictment of slavery ever penned, it might have been made a handbook for slaveholders and a first primer for dealers in human flesh.

THAT it was not, is entirely due to the manner in which the story was handled, "the way it was produced," as we say in film circles, and not at all to the theme itself.

* * *

TRUE of works of literature as this is, it is especially true of drama, whether on the stage or on the picture screen.

It is the same thing that makes the difference between "Hamlet," by William Shakespeare, and "Hamlet," by the average, "hand-me-down" playwright. The latter would, with precisely the same story, have made Hamlet a rip-roaring detective melodrama, or a "sins-of-society" problem play.

* * *

THE "shame" of the motion picture business—to use a Steffens phrase—is not the immoral or harmful picture, real or alleged.

The motion picture screen has purged itself of them, and powerful agencies at work within the business are on constant guard against them.

The real menace of this industry is the cheap, tawdry, shabbily costumed, badly acted, incorrectly and inartistically produced picture, as was emphasized in last week's editorial.

* * *

THOSE are the pictures that have kept the better classes away from the motion picture theatres.

Those are the pictures that have withheld the sympathy and support of the best elements in the community from the photoplay houses—sympathy and support which has only recently been offered to the exhibitors in any degree whatever:

One such picture does more harm to the reputation of the industry in the minds of the theatregoers than ten masterpieces of the photoplay art can correct.

* * *

MOTION picture production is no longer in the crude, faulty stage of experiment. It is to-day both a perfected art and an exact science.

The fact that pictures of the highest quality in every respect are being frequently and regularly produced proves that there is no possible excuse for the poor picture.

There is no EXCUSE, be it repeated. And there is only one EXPLANATION.

* * *

THE producer who deliberately puts a poor picture on the market does so because he is determined to make more money than he could make by turning out an article up to the standard.

The "get-rich-quick" virus is in his veins.

Such a producer is on a level with the manufacturer who sands his sugar, with the dairyman who sells oleomargarine for butter, with the clothier who palms off cotton for all-wool, with the green-goods man who sells a gilded brick for gold. He is a man getting money under false pretenses.

* * *

HE is the enemy of every exhibitor who is duped into renting his films, because he is deliberately destroying the asset of the audiences' good-will, which is of cash value to that exhibitor.

His films are libels on the industry.

Every such picture he releases makes it harder for the high-grade producer to retain his clients' confidence, and for the exhibitor to keep the confidence of his patrons as he should.

The "gold-digging" producer is the "yellow peril" of the business.

POPULAR PLAYS AND PLAYERS BUILDS STUDIO

A new and thoroughly equipped studio has just been established at Fort Lee, N. J., by Popular Plays and Players, Inc. Every convenience and apparatus known to the art of making motion pictures has been installed. The studio is so arranged that five directors can work at once. The New Jersey country lying back of the studio affords wide variety for outdoor scenes. With the establishing of its new plant, this enterprising producing concern will greatly increase its output. Its first production, Jacob Adler in "Michael Strogoff," was released on October 19. The demand for it was instant and has grown in increasing proportions ever since.

That this producing corporation expects to be very active is shown by the fact that contracts have just been closed with the estate of the late Hugh Conway for twenty-two of his biggest successes. The contracts will cover ten unproduced plays.

TWO ITALA SERIALS ARE UNDER WAY

Two photo-play characters, Tigris, the Super-Criminal, and Maciste, the physically perfect giant of "Cabiria," will be the subjects of two Itala series soon to be introduced to the American market. Work on both has been in progress for almost a year.

To fit the gigantic proportions of Maciste, the marvel of brawn, scenarios have been written that will admirably display his prodigious strength. Heroic adventures of the variety that makes his part in "Cabiria" one of salient power come to him early and often. Detailed announcements will be made in this publication later regarding each of those productions.

PAULINE FREDERICK ONLY WITH FAMOUS PLAYERS

It has now been conclusively verified that Pauline Frederick is under exclusive contract with the Famous Players Film Company, for whom she is to appear in a series of important film productions.

The Famous Players will present Pauline Frederick in her first motion picture characterization, within a short time, in the motion picture version of Henri Bernstein's emotional drama "Sold."

A little later she will also be seen in the Famous Players' production of Hall Caine's master-work, "The Eternal City," which was produced in Italy during the past summer with this star.

WOMEN CENSORS IN LOUISVILLE

Special to Motion Picture News

Louisville, Ky., Nov. 2.

The women of the Censorship Committee formed to pass upon the films which will be shown every Saturday at the Mary Anderson Theatre especially for the children of Louisville, have announced that they will meet once a week for the purpose of approving pictures submitted. The committee is composed of women prominent in club work.

Elsie Janis Signs with Bosworth, Inc.

Actress Leaves New York for Pacific Coast Studio, Where She Will Begin Rehearsals for "The Slim Princess"

BOSWORTH, Inc., has just signed up Elsie Janis, James K. Hackett, Dustin Farnum, George Fawcett, Maclyn Arbuckle and several other noted artists, who will appear shortly in Bosworth releases through the Paramount Program.

"No. Mr. Garbutt tells me his machines are as stable in the air as my automobile is on land, and as Mr. Garbutt is a man in whose word I have implicit confidence, I shall try out the sport for myself and see how I like it. Probably it will prove to be

BOSWORTH'S QUINTET OF STAGE CELEBRITIES



ELSIE JANIS

TOP: GEORGE FAWCETT, JAMES K. HACKETT. BOTTOM: DUSTIN FARNUM, MACLYN ARBUCKLE

Miss Janis, who left recently for Los Angeles, with her mother, a retinue of servants and her chauffeur, in accommodations that practically amounted to a private car from coast to coast, will probably appear first in "The Slim Princess," and also in an original scenario written by herself. Not only will she star in these productions, probably playing opposite Courtenay Foote, but she will learn a new art. Frank A. Garbutt, V. P., of Bosworth, an aeronautical expert of two continents, will teach Miss Janis to fly, and will place his fleet of aeroplanes at her disposal.

When asked if she was not afraid to begin this sport, which is commonly considered dangerous, Miss Janis replied:

a new sensation and very very fascinating indeed."

It is not improbable that Miss Janis will weave an aeroplane flight into one of her new scenarios in which she will be seen as the pilot. Mr. Hackett will appear in one of his most popular stage successes; Mr. Fawcett, the first college man said to adopt the stage, will probably act the leading part in his London success, "The Great John Ganton"; Mr. Farnum will probably be seen in "Captain Courtesy" and "Texas"; while Mr. Arbuckle, the well-known "Jedge," will doubtless play some of his popular pieces, one of which will be written by himself with Irvin S. Cobb as collaborator.

In and Out of Los Angeles Studios

Special to MOTION PICTURE NEWS

Los Angeles, Nov. 2.

VACATION days are over for the leads of the Ford Sterling Motion Picture Company, Mr. Sterling having arrived home from New York, Manager Fred Balshofer, from a hunting trip with ex-champion Jim Jeffries, spent at Bakersfield; and other leading people are back at work.

"The Dog Raffles" is a one reeler recently made at the Sterling studio, in which a trick dog plays the leading part of a crook story. The canine jumps through a window opened by his master, carries a stick of dynamite near a safe, strikes a match and lights the fuse, and then places it on the knob of the safe door. After the explosion the dog carries out the bags of washers—and performs other stunts. The picture was directed by David Kirkland.

Robert Thornby, of the Sterling camp has finished filming a kid black hand picture, in which George Jaeschke, made a successful thriller by jumping from a broken down auto being towed by another, to a machine passing at the rate of fifty-miles an hour. Jay Becker, another Sterling daredevil, rode the now famous one lung, 1901 model Oldsmobile of the studio police force down Cahuenga pass—which has a very steep and extremely long decline—without the use of brakes, that feature of the car's equipment having disappeared years ago. According to Director Beverly Griffith, it was possible to make photographs of this scene because yellow takes white photographically.

W. S. Campbell, formerly with Keystone, Mace comedies and R. B. producing companies, in capacity of scenario editor, is now sole occupant of the script room at Sterling studio.

Griffith Preparing Important Picture

Director General D. W. Griffith is rehearsing a company composed of Mae Marsh, Robert Harron, Marion Cooper and F. A. Turner, at the Majestic studio, for a two or three reel picture, but announcement has not been made of the title or the character of the picture, though it is expected soon.

"The Little Country Mouse," with Blanch Sweet playing the part of an unsophisticated country girl, the daughter of a clergyman, who succeeds in the gay social whirl at Newport, is being produced for Majestic release by Donald Crisp.

Wallace Reid is playing opposite Miss Sweet, as an army officer. Director Crisp has just finished filming "Another Chance," in which a tramp saving the life of a newsboy is rewarded by the lad preventing him being railroaded to prison.

Crisp played the part of the tramp, and the supporting company included William Lowery, Wallace Reid, and Mary Alden. The scenario was by George Hennessay.

The western garb has been hanging in

"cell No. 3" at the Reliance studio and Arthur Mackley is producing the first picture of other than western atmosphere for a year or more. This one reeler is "They Never Knew," a heart interest tale, a romance of two childhood sweethearts. Florence Crawford, Vester Pegg and R. A. Walsh are the principals.

Helen of the Herald—Miss Irene Hunt—is appearing before the camera at the Reliance for the fourth newspaper story. The title of this is "The Hop Smugglers," and in it the "sob" sister materially aids the revenue officers in locating Chinese opium smugglers, secures a big beat for her paper, and incidentally, of course, plays a star part in a pretty romance.

WATCH ACCESSORY NEWS

Pages 69 to 82

Rex, Bull Terrier, Featured

The activity of Rex, the Boston bull terrier owned by Fay Tincher, in stealing men's hats and taking them to his mistress' dressing room at the Majestic studio, led Director Eddie Dillon to film "A Corner on Hats," in which Rex is featured.

The jealous husband, so the story goes, beats up several men, dynamites the police station, and numerous other desperate deeds when he finds a number of men's hats in a closet of his home, with no solution as to how they got there. The scenario was prepared by Anita Loos, the 18-year-old photo-playwright, of San Diego, following a visit at the studio here where she saw Rex perform.

Joseph DeGrasse has filmed "The Peacemaker," at the U studio, from the scenario by Ida May Park. This is a pretty drama, which the uncle leaves to his niece and prospective husband, a beautiful old man-

tion. Before death he gave to each a key. A few days before their wedding a scandal monger tells the maid of stories being heard concerning her intended husband. She decides to hide herself in the old mansion until talk regarding the broken engagement subsides. Jack decides to go there and drown his troubles in some of the rare wine left by the old man, who had been the peacemaker for them in several quarrels.

They arrive at a time crooks are ransacking the place, and following the departure of the burglars, the vision of the old man appears and their differences are righted. The picture features Pauline Bush, William Dowling and Charles Manley.

Taking the advice of his former college chum, now a doctor who is about to leave for a vacation, and desires him to accompany him. Henry Peck, played by William Franey, in "The Doctor's Orders," produced by Allen Curtis for Joker release on U program, leaves his wife in the care of mother-in-law. The ocean trip, spoken of to his wife, consisted of a stay at the beaches. Then comes news of the sinking of the liner the men were supposed to sail on and wife thinks herself a widow.

The men, to explain matters, rig up a life savers row boat and put to sea, that they may be rescued. They are brought ashore by a steamer and gain much publicity by stories of their escape and battle with the elements. The ocean liner, supposed to have been sunk, docks safely and the pair find themselves unable to explain.

The Brand, a two reel Indian war drama, with an unusually pretty romance, is being completed by Henry McRea and company, including William Clifford, Sherman Bainbridge, Marie Walcamp and Lule Warrington. The story, by H. G. Stafford, is in three episodes.



THE "ROSE IN THE RING" COMPANY'S CIRCUS AT THE LASKY STUDIOS, HOLLYWOOD, CAL. (Posed especially for Motion Picture News.)

"The Master Key," Universal serial, Rex company, including Robert Leonard, director and lead, Ella Hall, Allen Forrest, Harry Carter and William Higby, went to San Francisco, Monday, where they made scenes for the fourth and fifth installment of the serial.

As an appreciation of the aid rendered by Manager Isadore Bernstein to the Hollywood Board of Trade and Chamber of Commerce in the recent celebration held in the foothill city the two bodies have presented the Universal officer with a handsome cut glass vase standing nearly three feet in height and weighing twenty-five pounds, and have elected him to honorary membership in their organizations.

Superintendent Bob Stevens and crew of auto repair men of the Universal garage spent two days in removing valuable parts of the auto wrecked for "Trey o' Hearts," No. 14, on a steep incline in one of the canyons north of Hollywood. At first it was attempted to remove the car, but finding this impossible the parts of value were removed.

There is a new photo player in Hollywood, and as a result acquaintances of William Worthington, character lead for Turner Special Feature Company at the Universal studio are smoking black cigars.

William S. Hart, originator of the character of Cash Hawkins in the original stage presentation of "The Squaw Man," has arrived at the New York Motion Picture Company studio, Inceville, at Santa Monica, where he has begun his work as director and actor. He will remain at the studio permanently, a long time contract having been made.

Mr. Hart appeared in two other Ince features, playing the lead in the Grand Canyon picture, "The Two-Gun Man," and he supported Robert Edeson and Rhea Mitchell in "On the Night Stage," both of which have been completed but not as yet released.

Ince Insures Players

Thomas H. Ince is the first west coast director to insure his players, he having purchased a \$25,000 policy for George Beban. This action was taken following a recent accident in which Beban nearly lost his life under a street car, after falling from an automobile.

George Beban, J. Frank Burke, Clara Williams and a number of other members of Inceville studio stock company are at San Francisco, making scenes for "The Italian," D. J. Beban, chairman of the state senate docks and wharfs' committee, and Louis G. Beban, associate surveyor of customs at San Francisco wharf, are brothers of the actor, and this relationship will prove of value to the photoplayer and supporting company. Reginald Barker is in charge of the production at the Bay City.

Director Walter Edwards, Frank Borzage, Jerome Storm and other members of the New York Company who have been in Bear Valley—at an altitude of 8,000 feet—for the past few weeks, filming "The Panther" and "In the Land of the Otter," have arrived home with tales of winter weather, snow storms and zero temperature in the mountainous country eighty miles from Los Angeles where the days for the past two weeks have been

uncomfortably hot for both man and beast.

Shorty Hamilton is being featured in another Shorty comedy under the direction of Richard Stanton at the Inceville studio. The title of this is "Shorty's Secret," and like previous releases of the series will be of a semi-western character.

Realism? Eggsactly!

Expenses do not matter to Inceville producers, as will be shown by this pic-



MABEL NORMAN IN "SEA NYMPHS"
(Keystone—Two Reels.)

ture, for they are going to have an egg fight with real eggs. Mercy! And they're forty-five a dozen, too.

Director Jay Hunt and producing company have just completed "The Spirit of the Bell," and have begun filming "The Fortunes of War." Both are stories of Mexican life, and the company will penetrate the warring neighbor's territory, and spend several days there in order to secure correct settings. Enid Markley and Charles Ray play the leads in both pictures.

"The Flower of the Desert," a melodrama depicting the sad life of a baby girl, buffeted about by an unworthy mother and renegade father, is being made under direction of Scott Sidney at Inceville, with J. Barney Sherry, Leona Hutton and Harry G. Keenan playing the principal parts.

Director Marion De LaParelle, in charge of the production of the Masterpiece Film company, recently began production of the second picture, "The Truth Wagon," which like the first release of this organization will consist of five reels, and feature Max Figman and Lolita Robertson.

Other members of the cast will be A. W. Filson, formerly with the Griffith and Selig companies, as Francis Sullivan, king of Tammany Hall; Dick Rossin will characterize the degenerate reporter and Edward Harley will play the character part of the disheartened owner of the newspaper that failed by telling the truth.

One of the features of the picture will be a ballroom scene in which a number of Hollywood and Los Angeles society

women will take part. One woman learning the picture would need such a scene, graciously offered the use of her home to be used in place of sets, and will invite her friends to take part in the scene. There will probably be eighty or more to take part.

"Advice to the Lovelorn"

Elliott Clawson, who is preparing the scenario, is finding so many clever bits of conversation in the original play that he is having a big battle with himself to decide which shall be used for subtitles in the form of conversation. He has added one very important character—that of Cynthia Grey or Beatrice Fairfax, who deals out advice to the lovelorn.

Col. William N. Selig, president of Selig Poloscope Company, arrived in Los Angeles recently for a stay of two or three weeks at the Edendale and Jungle Zoo studios, watching the progress of the filming of "The Rosary," by Director Colin Campbell at the former, and superintending the finishing touches of the buildings and grounds at the Selig Jungle Zoo at the latter.

This is Mr. Selig's first visit to the West Coast since early in the summer, and since that time he has spent several months in Europe; in fact having arrived home but a few weeks ago. It is his intention to return to Paris as soon as the Zoo is opened to the public, and he completes some business matters in Chicago.

Frank D. Williams, in charge of the most recent addition to the Balboa Feature Films studio at Long Beach, Kids Comedy Kompany, has the distinction of being director, cameraman and sometimes gets another crank turner to take his place while he takes part in a scene, all in addition to being his own scenario writer.

Of his company Little Olive Johnson, age three years, is the star, and Violet Radcliffe, age five, plays the lead boy part opposite.

This is not Olive's first engagement for she has been with a number of other local producing companies, where she learned to swim, ride and do many fancy dances. Director Williams has had a world of experience, being connected with Pathe in France, and Keystone, Alco and Essanay in this country.

Director Colin Campbell, Kathlyn Williams and several other members of the Selig "Rosary" company autoed to near Riverside, where symbolic scenes with Miss Williams prostrated at the foot of the famous timber cross on top of Rubidoux mountain were made.

Van Loan Story Being Filmed

Members of the Selig companies were grief stricken when the wife and infant child of Clyde Garner, superintendent of the studio garage, were ground to pieces under a street car, a short distance from the studio, while Mr. Garner was waiting for them on the curb.

Hobart Bosworth, Charles E. Van Loan, Courtenay Foote and members of the Bosworth producing company are at Banning, Cal., making exteriors for "The Message from Buck Shot John," an adaptation from

a Van Loan story appearing in the *Saturday Evening Post*, in four reels.

In a recent letter Mr. Bosworth wrote that he and the company were receiving unusual attention and assistance of every kind from the people of the town. When a big chase scene in which a posse composed of cowboys, citizens, women and children were needed the merchants closed their stores, the schools were shut down, and everybody took part in the picture.

Ott Accord, famous cowboy, and winner of numerous medals at the recent Pendleton, Ore., round-up, is taking part in the picture and has made several good falls within a nine-foot line. Rhea Haines will play the character lead and Helen Wolcott the ingenue in this subject.

The Smalley-Weber Bosworth company, after a vacation of a week, are now at the Midway, Cal., oil fields, making a four-reel picture from a story by Louis Weber, the title of which is "Sunshine Mollie." Mr. Smalley and Miss Weber are playing leads, and Adele Farrington the character part.

Oz Completes "Last Egyptian"

The Oz company players have completed the fourth subject, "The Last Egyptian," consisting of five reels, and the first screen examination will soon be made. All the members are enthusiastic regarding this production from the well-known novel by L. Frank Baum. The settings are described as being as elaborate as those of previous releases, "The Patchwork Girl" and "The Scarecrow of Oz," even though this picture is not of the fairy story type, but all scenes being laid in either Egypt or London.

Members of the producing company of the Favorite Players, a number of photographers, directors, exchange men and exhibitors witnessed the first projection of the most recent production, "The Man Who Could not Lose," from the story of the same name by Richard Harding Davis, made by Carlyle Blackwell, Friday evening, October 23, at Clune's Auditorium Theatre, after the regular evening programs, and Monday the negative and positive were shipped to the factory in New York. This will constitute the November offering of the Favorite Players for Alliance.

The story of this picture can best be described as a story within a story, it being the portayal of a young author, Champneys Carter (Carlyle Blackwell), writing a story for a publisher, and shows by double exposure photography and otherwise the vision of the young man at the typewriter. His story is largely one of past and almost present experiences, in which romance, speculation, adventure and strife for success play important parts.

The leading parts in addition to that taken by Mr. Blackwell are: Jackson Carter, a gambler, Hal Clements; Count Lecoff, a fortune hunter, William Brunton; Rev. Orlando Stone, John J. Sheehan; Spink, a publisher, J. M. Strong; Sol Burbank, a broker, Thomas Delmar; Herbert Ingram, Henry Kerner; and his daughters Dolly and Melisse, Ruth Hartman and Gypsy Abbott, respectively.

The company has begun the production of "The Last Chapter," from Mr. Davis' novel, "The Unfinished Story," scenario for which was prepared by Richard Willis.

Pacific Studio for Horsley

That David Horsley will soon begin production on the West Coast is the message brought to Los Angeles, in a telegram to Charles C. Fais. In this the owner of the Centaur company advised his former purchasing agent to locate a suitable piece of property for the largest studio in the West, and report to him by wire.

When Mr. Fais received this message he was in the employ of a newly organized producing company, but within five minutes he had tendered his resignation and was on the way to find site for his former employer. It is very probable Mr. Horsley will arrive here soon and complete arrangements for his new plant.

The Work Family, including Willie, Helen and May, the children, are soon to appear in comedies. A series is now being made by the Rolin Film Company, releasing through Sawyer, Inc., at the Court street studio, under the direction of H. E. Roach. Harold Lloyd is the leading comedian, playing the part of Willie.

Arrangements for the release of the Loftus feature films, featuring Arthur Maude and Constance Crawley, through Sawyer, Inc., have been completed here by the Rolin Film Company, acting as agents for this releasing company. The subjects are all of four reels and include "The Virgin of the Rocks," "The Massacre of St. Bartholomew" and "Thais."

A two reel picture, "Lure of The Windigo," has been made under the direction of F. J. Grandon, at the Selig jungle zoo. This is a Canadian north woods subject in which Lamar Johnstone plays the part of Kiawa, an Indian, and is supported by Edith Johnson, Frank Mayo and Barney Fuery.

Funny Bachelor Film

The Thomas Santschi Company has made a newspaper story picture, "Just Like a Woman," written by W. C. Clifton, of the Selig scenario department.

"Bingo, The Merry Bachelor," is a com-

edy made by the Norval McGregor-Selig company, which deals with the attempts—and success—of insurance men to sell the bachelor a policy. John Lancaster and Lillian Leighton plays the leads.

"The Lure of Adventure," is a comedy of club life, in which the wealthy young member makes a bet with friends that he will not have an unusual experience within a certain time.

His friends see to it that he does, and soon he is enticed to a supposed counterfeiter's den by a girl he thinks the daughter of the counterfeiter, who in reality is sister of his friend at the club. William Stowell and Mary Werner are playing the leads. E. A. Martin is director.

Capt. Wilbert Melville has arrived home from a trip of six weeks in the East, and work of production was begun at the Lubin western studio by Director Paul Powell. The stock company of the studio includes Velma Whitman, Melvin Mayo, L. C. Shumway, George Rouch, and Robert Grey, and this week the company is filming "An Ambassador from the Dead," an industrial subject dealing with the conflict between capital and labor.

Durham-Smithman

Dan Cupid is working overtime at the Inceville studio at Santa Monica. The latest victim is Lewis "Bull" Durham, ex-Giant pitcher, who was wedded Monday evening, October 26, to Edith Carmen Smithman, a musician of Los Angeles. When Bull, as all his friends at the studio call him, was sixteen years old, in company with his uncle, he spent a week at Remersburg, Pa.

At the house next door was a little four year old girl, and for want of other playmates he teased the little tot. Two years ago the former star pitcher, and popular leading man of today, came to the West Coast and opened a grocery store. One of his patrons introduced him to Miss Smithman, and through this acquaintance they learned they had played together years ago.



THE SCHOOLMASTER IN THE HANDS OF HIS ENEMIES
(Scene from "Hoosier Schoolmaster"—Masterpiece Film)

VERSATILE BETTY HARTE HAS VARIOUS CAREER

Betty Harte, one of the most beautiful actresses on the screen today, started her theatrical career in a stock company in Los Angeles, and after two successful seasons, decided to try her hand at motion pictures.

She applied for an engagement and succeeded in entering into a contract with Selig as the leading woman in the western company, where she worked opposite Hobart Bosworth.

She first became famous in Selig's two animal pictures, "King of the Forest" and "Bounder." Feeling that her talents as an emotional actress did not find full scope with Selig, she joined the Edison company, where she was promised a greater opportunity.



BETTY HARTE.

Soon after she joined the Famous Players, going to Cuba with Daniel Frohman.

When the Victory company was formed by Searle Dawley, J. Parker Reed and James Gordon, they immediately selected this well known star to take the varied leads in a number of plays that they had selected to be filmed in Bermuda. In the three plays released to date by the Picture Playhouse Film Company, "The Oath of a Viking," "The Next in Command," and "The Mystery of the Poison Pool," Miss Harte has shown not only her wonderful ability as an actress, but her versatility in many ways, and always with artistic success.

WATCH ACCESSORY NEWS

Pages 69 to 82

Dallas Exchange Takes Kinetophote Output

Scott Will Control "Markia," "Spirit of the Poppy," and Others for Texas, Oklahoma, Louisiana, and Arkansas

THE K. C. Booking Company, Incorporated, which handles all of the features made or otherwise controlled by the Kinetophote Corporation of 126 West 46th street, New York, has signed contracts with C. R. Scott of the Dallas Film Company of Dallas, Texas, to take all of the output of the Kinetophote for Texas, Oklahoma, Louisiana and Arkansas.

Mr. Scott was very optimistic about conditions in the Southwest. He remarked that the exchanges in that large slice of the United States were expecting the biggest business in years this fall and winter.

"And I want to say right here," he added, "that the exchange with the big features to book is the one which is getting the business right now, especially in Texas. I am pleased with the offerings of the Kinetophote, especially with 'Markia' and 'The Span of Life.' The first is a second

'Cabiria' to my way of thinking and will take as well with our people, because it has a heart interest stronger than that found in 'Cabiria.'

"'The Span of Life,' is known to everyone in our smaller cities, because nearly all of our people have seen the road companies in Sutton Vane's melodrama. Then, again, the name Barrymore has a potent appeal to all of our theatre goers, and with Lionel Barrymore in the film, 'The Span of Life' will be a big drawing card in our territory.

"With 'The Coming Power,' we will do much business because every Southerner loves a story of political intrigue. And 'The Little Jewess' will prove a winner. 'The Spirit of the Poppy' is a great big moral lesson which I expect to see taking well with the exhibitors in our section of the country."

Another Large Company Formed in California

Malibu, Incorporated at \$200,000, Organized to Produce One, Two and Three Reel Plays and Industrial and Educational Subjects

Special to MOTION PICTURE NEWS

Los Angeles, Nov. 1.

THE Malibu Motion Picture Company, a California closed corporation, with a capital stock of \$200,000, will begin production shortly at one of the local commercial studios, while their studio is being constructed. The company intends to make one, two and three reel comedies and dramas, and educational and industrial subjects, with the first release about the first of December.

The directorate of this new company is composed of well known and highly rated business men. Roger M. Andrews, formerly director of Citizens' Trust and Savings Company and president of the Los Angeles Ad. Club, is president; W.

Irving Truck, president of the Southern California Fish Company, the largest canning company on the southwest coast, is vice-president and treasurer; Carl E. Rosenbert, owner of most popular German paper on the west coast, is secretary; John E. Brada, formerly assistant auditor of the Union Oil Company, is general manager; H. Ellis Wales, a magazine and New York "World" special writer, will be scenario editor; Robert A. Brackett, for seven years motion picture exhibitor in St. Louis, San Francisco, Chicago and Los Angeles, will have charge of production, and Walter H. Schulze, for a number of years demonstrator for Eastman company, will superintend the photographic department.

Henry Pessers Takes Trip to America

Leaves London to Study Conditions in the New World, and Complete Plans for Further Distribution of Balboa Films

HENRY PESSERS, a director of the Bishop, Pessers and Company, Ltd., will arrive in New York shortly.

This is Mr. Pessers' first trip to America, but he has been wanting the opportunity to visit our shores for many years past, and it has at last come.

Previous to forming the company, Mr. Pessers had become interested in exhibiting and four years ago built one of the finest provincial picture theatres in England, costing \$100,000. Since the formation of Bishop, Pessers and Company, Ltd., he has taken a deep interest in the film business generally and has had the satisfaction of seeing this company established in a very strong position in Europe.

It specializes principally in Balboa films, which are rapidly coming to the front in the United Kingdom. It is partly in connection with some large and ambitious plans for distributing Balboa and other films in Europe, that Mr. Pessers has made the trip. The firm is already a force to be reckoned

with in London and we have every reason to anticipate a very rapid advance to one of the leading positions in the film world that side of the Atlantic.

ALCO BOOKS MANY CITIES IN NEW YORK

C. A. Taylor, who is traveling through New York State in the interests of the New York Alco Film Exchange, reports to the home office that he has closed contracts for the Alco program in the leading cities of the state.

Albany, Syracuse, Buffalo, Rochester, Watertown, Ogdensburg, Binghamton, Rome, Amsterdam, Gloversville, Corning, Cornell, Troy and many other cities are now taking the Alco program. To one theatre in each city the service is given exclusively. The new Palace, Buffalo, which opens in December, and the Gordon, Rochester, N. Y., both have signed for the Alco program.

SOME SECOND MRS. TANQUERAY"

(Warners—Two Reels)

REVIEWED BY PETER MILNE

Production in motion pictures of "The Second Mrs. Tanqueray" is another proof that the far-sighted producer would stage productions will not miss their mark now. It is remembered that this same play created much comment on in New York, and gained a widespread name for itself as a picture wherever pictures are known to be shown.



THE SHOT IS HEARD

The story is a tragedy, and in the short space of two reels ample opportunity has been given to develop some unusually tense situations. These opportunities have, for the most part, been utilized by the two leading persons in the cast, Arthur Maude, who plays Tanqueray, and Constance Crawley, who plays the part of his second wife.

Miss Crawley's characterization of her role is of the spirited emotional style of acting, while Mr. Maude's is more controlled, but none the less expressive.

The rest of the cast perform in excellent manner and accord with Miss Crawley real support.

On the screen the story seems inoffensive and particularly interesting. It is true melodrama, and due to its remarkably well built situations will keep a firm grip on its audience throughout its entire length. The settings, although nothing extraordinary, are in good keeping with the story and present just the background for the drama.

The photography is distinct and the light good.

The central figure of the picture is a woman with a past, and a very gay past at that. She marries a widower, and becomes greatly attached to his young daughter. A Captain Ardal falls in love with that young lady, and when the young woman introduces her husband-to-be, the second Mrs. Tanqueray discovers that he is no other than an old lover of her own. She returns to her room, and soon after the occupants of the house are startled by a shot, and they learn that the woman has taken her own life so that her step-daughter may be happy with the man she really loves.

"THE WISHING RING"

(World Film—Five Reels)

REVIEWED BY PETER MILNE

THIS is something engaging, something fascinating about this pretty little comedy-drama that results in it being unusually attractive, even though the whole story could have been told in far less space than five reels embrace. And beyond a doubt its magnetism lies, for the most part, in the excellent interpretations rendered by the leading players of the cast.

Featured in the production is Vivian Martin. To her falls the part of Sally, the parson's daughter, who very naturally is poor but at the same time happy. The performance rendered by Miss Martin is delightful, to say the least, and if she appears before the public in many more roles so suited to her personality, it is a safe guess she will become a great favorite.

The opposite part is played by Chester Barnett as Giles, the son of the Earl of Bateson. A part has been given him which suits his appearance and actions perfectly. He is seen first as a care-free schoolboy, so carefree that he is expelled from school. Then he quarrels with his father, and finally after he has grown to love Sally, he and his father are reconciled because of her efforts.

Alec B. Francis appears at his best, which is excellent, as the gouty old earl. He, too, is well suited to his part, and it seems after witnessing his performance that if it were held by any other it would lose much of its color and charm. For the rest, John Hines as one of the jolly boys, and Simeon Wiltisic as the parson are the most important. A large supporting cast appears.

"THE PERILS OF PAULINE"

(Eclectic—Seventeenth Episode)

REVIEWED BY CLIFFORD H. PANGBURN

IF the terrors which beset the much persecuted Pauline seem to become worse with each instalment, her fiance becomes correspondingly more heroic. In this chapter, episode seventeen, he overcomes some eight or ten burly ruffians singlehanded, and

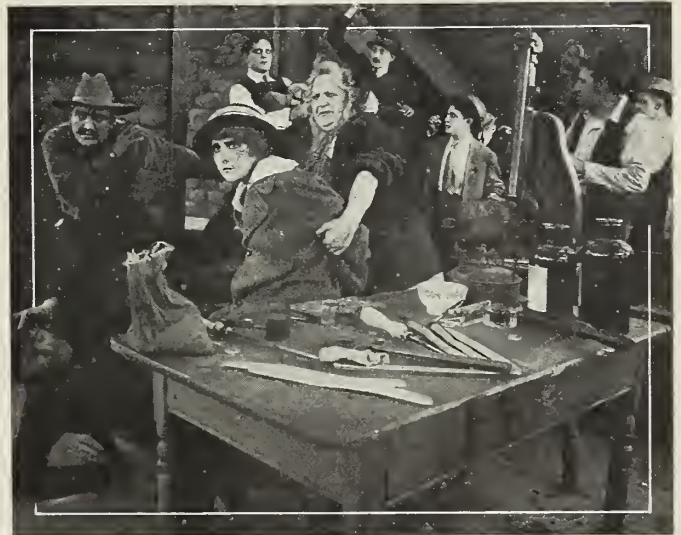

CAUGHT BY THE COUNTERFEITERS.

snatches his sweetheart from their midst. Later his marksmanship appears to be much at fault, but as this makes a fierce hand-to-hand conflict possible it only adds to the excitement.

One of the most interesting features of the picture is a small white bulldog, who acts with an intelligence considerably in excess of that manifested by some human players who have appeared on the screen. After a long series of surprising stunts he caps the climax by running for a long distance, carrying in his mouth a supposed bomb from which a lighted fuse is trailing. With this he jumps from a bridge into a river and swims a considerable distance. The extent to which he ambles about alone in the scenes is really remarkable.

Pauline's dog is stolen by a friend of the chief villain. She advertises for it, and follows up an answer only to fall into a trap. The dog escapes and brings the redoubtable Harry to the scene. He rescues her, but the motorcar in which they are escaping breaks down, and they have to take shelter in a cabin. There the pursuers are kept at bay until help comes.

"SLICE OF LIFE"

(American-Mutual—Two Reels)

REVIEWED BY T. S. MEAD

LOSS of memory through physical accident has been used as the basis for many interesting stories, but to put such a story across on the screen requires a lot of histrionic ability. Ed Coxen, playing the role of Jim in the "Slice of Life," has proved himself entirely equal to the difficult task.

Winnifred Greenwood in the part of Betty Norse takes full advantage of her many opportunities to make this an unusually interesting production. A good cast supports these principals, and particularly excellent is the juvenile acting of Cupid Cavens.

With the aid of such a cast the story is cleverly developed from the point where we see the accident that results in the unknown Jim's loss of memory to the, at least not too obvious, climax where Jim accidentally stumbles upon his wife and family and recollects all the incidents of his past life.

During this time our attention is cleverly held by an abundance of human interest, centering around the gradual growth of love between Jim and Betty. Literary talent, which they both possess, throws them constantly together. Jim, however, is too honorable to speak of marriage until the mystery of his past life has been cleared.

At this point we see a mother and two children forced by poverty to give up their pretty home for a tenement room where they are having a hard time to eke out a bare existence. Betty discovers this pitiful family and brings them much-needed assistance. A few days later, thinking that she has discovered material for a real story, she takes Jim with her to visit the tenement.

At sight of Jim, the mother rushes forward with the cry of "My husband!" Jim's memory surges back and Betty realizes that the man she has grown to love is lost to her forever.

"THE TREY O' HEARTS"

(Gold Seal-Universal—Fifteenth Chapter)

REVIEWED BY PETER MILNE

THE last chapter. Alan Law has now no more cause to worry about his life and the mysterious death sign, "The Trey o' Hearts," which was forever being placed in his path by his bitterest of all enemies, Seneca Trine. And that most villainous of all villains is now out of the way, and never will be in the way again, as this last chapter puts an end to his evil life. And as one of the



JUDITH DEFIES ROSE

sisters had to be disposed of in some manner, it comes as no great surprise that Rose was the unlucky one, as Alan's attitude has been growing warmer toward Judith in the latter chapters.

Marrophat and Trine's secretary were disposed of in the preceding instalment, and Trine and Rose, who are struck by lightning here, make the total of fatalities four. It develops that the interrupted wedding between Alan and Judith which took place some episodes back, was not interrupted soon enough to nullify the marriage, so for the last few chapters Alan and Judith have really been man and wife, although not many suspected it.

The three reels that this chapter embraces make a fitting finale to

the thrilling serial. The introduction of Bess Meredyth, the scenario writer, and Wilfred Lucas, the director, is a very excellent idea. Everyone who has followed the story will be extremely glad to get a glimpse of two of the persons, who have been responsible for so much of its success. Then again most of the scenes of the three reels were filmed in the beautiful rooms of the Mission Inn at Riverside, California.

In the wedding of Alan and Rose, which is only interrupted at the last moment by the stroke of lightning which takes the life of Rose and Seneca Trine, a very impressive and elaborate affair has been staged. And Trine was not a happy spectator of the



JUDITH AND ALAN UNITED

ceremony. Far from it. Through a lucky fall he had regained the use of his long paralyzed limbs and was about to shoot our hero when the bolt from the clouds interfered.

There will not be many among the followers of "The Trey o' Hearts" who will welcome its termination. They will regret it and more than likely wish there were more of the same high class thrillers to follow.

But all good things come to an end. And instead of bemoaning its close we should stop to thank all who were concerned in its production. To Cleo Madison, George Latkin, Tom Walsh, Ray Hanford and Ed Sloman, the principals of the cast, the heartiest praise is extended.

The numerous stunts they performed were never less than hair raising, Wildred Lucas, the director, is not to be forgotten. His name, like that of Francis Ford's, will long be remembered by motion picture goers. And the author, Louis Joseph Vance—well, he'll have to fly pretty high to surpass the mark he set by this story.

"HIS TRYSTING PLACE"

(Keystone-Mutual—Two Reels)

REVIEWED BY PETER MILNE

CHARLES CHAPLIN again, playing opposite Mabel Normand in a two reel laugh maker comprising the third multiple reel Keystone release. Charles Chaplin's work need not be described. He plays his part here, the irate and slovenly husband, who at length has to acknowledge his wife as the boss, in his usual way. His actions, his facial expression, what little there is, and his inimitable walk, are just as funny now as ever.

Mabel Normand plays the busy wife, and roundly abuses her husband more than once. And the way she does it, and the manner in which he accepts the abuses are uproarious.

Narrowed down, the story is the one of the changed overcoats in the restaurant and the contents of the pockets causing trouble. The characteristic incidental actions which Chaplin introduces are enough to cause one to forget the plot's conventionality.

Imagine this: He saunters into an eating place, an old man is seated at the lunch counter devouring a plate of crullers or some other form of dough. Our hero naively picks up one and tries it. Not finding it suitable to the especial requirements of his palate, he throws it down and suavely wipes his hand on the old man's beard, to the latter's great surprise and disgust.

The picture is full of just such little incidents as this, all of which are equally humorous, and unite to make the production one of the best of its kind.

"THE BURGLAR AND THE LADY"

(Warners—Six Reels)

REVIEWED BY PETER MILNE

THERE is always a welcome awaiting a well-known person whether he appears on the screen or the stage. It matters little if the person can act or not, his prominence will more than likely overbalance any dramatic shortcomings. But this production boasts of both the renowned person, and aside from that, good acting rendered by all the people in the cast.

James J. Corbett is the central figure of the plot, and he doesn't play the part of a prize fighter, but a role even more entertaining has been allotted him, that of a gentleman burglar and a detective.

Part of the time he is ready with a smile and a cigar for the police captain, and the rest of the time, which is considerably greater, he is ready with jimmy and skeleton key and all the other accompaniments of a Raffles.



THE PERFECTION OF NONCHALANCE

Anyone who has ever seen Mr. Corbett will realize that his manner and bearing suit him remarkably well for the part, and as he played the same role on the stage several years ago, his acting carries a finish and polish that would otherwise be lacking. Claire Witney plays the girl who is responsible for Danver's reform, and Fraunie Fraunholz, Danver's assistant in crime. The rest of the performers, including Stone, the detective and the father of the girl, are well cast.

Under the direction of Herbert Blache the photographic and lighting effects have been well taken care of. A great part of the action takes place in a dim, mystifying light, which creates a fine effect. The story is so well constructed that the attention is not lost for a moment.

We have been overwhelmed with crook stories as we have with Westerns of varying degrees of merit, but even though this one may be built along lines that are more or less conventional it comes far from being a bore, and the chances are that everyone will be delighted with it.

No greater praise could be accorded it than to say it is the best that Warner's Features have offered for a long time. It will be remembered and appreciated.

In the adventures of Danvers, the Raffles detective, a wonderfully strong and well-built story has been presented. He turned crook by no wish of his own, and his detective work acts as a shield for his more shady pastime. Stone, the other detective, tries very hard to bring Danvers to bay, but however near he may come to his mark he is never successful. Danvers gives himself up to him in the end, serves his term, and then returns to the girl that was the cause of his reform.

FAMOUS PLAYERS SECURE RIGHTS TO "ZAZA"

DIRECTLY following the important announcements that the Famous Players Film Company has secured two such celebrated dramatic successes as "David Harum" and "The Old Homestead" comes an authoritative statement from that company that it has now obtained the film rights to the emotional drama, "Zaza." This stage triumph was the starring vehicle of the noted

French actress, Mme. Rejane, and our own American stage celebrity, Mrs. Leslie Carter.

In this film version the Famous Players will star Pauline Frederick, who has won unusual distinction in the current success, "Innocent," and who has already completed engagements in two forthcoming Famous Players productions, "Sold" and "The Eternal City," the first of which will be released during the next two months. As contained in a recent announcement, Miss Frederick is under exclusive contract with the Famous Players Film Company for a series of film characterizations.

This production will be the first release of the Famous Players Film Company in affiliation with Charles Frohman.

"THE MILLION DOLLAR MYSTERY"

(Thanouser—Twentieth Episode)

REVIEWED BY PETER MILNE

ALTHOUGH the mystery remains in practically the same secluded state in this episode as it has remained heretofore, a very small ray of light is given. It is so small, however, no definite conclusion can be formed from it. It is, perhaps, the beginning of the end, which is due to arrive after six more reels have terminated.

It is the note which the conspirators stole from Florence, and which she in turn stole back from them which causes all the trouble in this chapter. After Flo has been rescued from the water by Jim and the dog she gives the precious note to her lover. In making his toilet Jim conceals the paper in his tie, and then sets out to visit the girl of his heart.

His precaution served him well, for as he enters the grounds of the Hargreaves mansion he is attacked by Braine and a number of his band. They beat him up in a general way, but are unable to find the note, even though his tie is pulled off in the scuffle. Jones, the faithful butler, comes to the rescue, and Jim is taken to the house where the paper is examined.

It is found to be absolutely blank, but when Jones holds it over a candle hand-writing appears telling that the Russian ambassador has in his possession papers which will disclose the



BRAME'S OPPONENTS ARE HELPLESS

whereabouts of the vanished Hargreaves. Jones repairs to the hotel to see the ambassador and explains matters. He receives some papers from the Russian, but their contents are not disclosed.

The two leave the room, and Braine who has spied on the butler enters and searches for the papers. Jones and the ambassador return, having forgotten something, and then follows one of the realistic fights that have been so prominent in the entire production. Braine comes out victorious, and escapes from the room, locking the door and trapping his enemies.

Perhaps those who have made a study of the serial will be able to foresee what the papers contain in the way of reading matter. If they can they are much nearer the solution of the mystery. But the chances are that they will be as much in the dark as ever.

It is evidently the intention of the producers to conceal the ending up to the last moment, and perhaps not to give any termination whatsoever, leaving the guessers to form their own conclusions, and then announce it later. But whatever their intentions, they are certainly as mysterious as the far famed story itself.

Minneapolis Convention a Model Meeting

(Continued from page 20.)

due to my affiliation with a film exchange, this is a very delicate matter to treat upon.

"Again I want to thank each and every one of you, ladies and gentlemen present, for what you have done. This convention as you all know, has been a most wonderful success and the greatest ever, and in behalf of Mr. Johnston, the MOTION PICTURE NEWS, and myself, I again thank you very much indeed."

The Banquet started at seven o'clock. A splendid surprise was bestowed upon B. N. Judell, manager of the Mutual Film Corporation, Minneapolis, who was recently married, and had just returned from his honeymoon, and it was so arranged that he would be the last one to enter the banquet hall. Just as he approached, the organ played Mendelssohn's "Wedding March," among cheers and applause.

James Gilowsky acted as toastmaster. Rev. G. L. Morrill offered prayer and the feed was on.

Convention "National Hymn"

The first speaker called upon, was Harry H. Green, president of the M. P. E. A. of Minnesota. Mr. Green shortly dwelt upon the wonderful success of the convention, and the splendid gathering assembled at the banquet, and read off the following song which was unanimously adopted as the "national hymn" of the M. P. E. A. of M.:

This is what I'll tell to you,
Best Convention that ever grew;
M. P. E. A. will be fine,
1915 is the time.

The next speaker to be introduced was Chief of Police Martinson, a man who at all times has been fair and square in his dealings with the local exhibitors. Mr. Martinson mentioned the fact that he considered moving pictures today the best educator on the market, and concluded his talk by saying that: "As long as you exhibitors put on the kind of pictures you have in the past, and co-operate and work with us in the same manner, you will have nothing to fear from the police department, I assure you."

B. N. Judell of the Mutual Film Corporation started to make a speech, but everybody insisted on seeing the bride, and so his intended oratory was short but sweet and pertained chiefly to his honeymoon rather than anything else.

Tom Gleason, local moving picture censor, was next called upon, and spoke along the same lines as did his superior officer, Chief Martinson. His speech was received with equal enthusiasm.

The next speaker, and by the way, without a doubt the headline on the program, was Rev. G. L. Morrill. I have heard Morrill so often and know him so well that I can't appreciate his talk any more than I did on previous occasions. That would be impossible. That man can say more in five minutes than I could write in a day, and the applause that followed his speech lasted for fully five minutes. It takes Morrill a long time to get through when he starts, but when he is through no applause will ever get him back.

The toastmaster then called upon James V. Bryson, manager of the Laemmle Film Service, but was excused by Fred S. Meyer, assistant manager, who made a few well chosen remarks, thanked those assembled in behalf of the Laemmle Film Service, as well as MOTION PICTURE NEWS, for the opportunity of being in their midst on that occasion when the fact was mentioned that Al. Steffes, secretary of the League, was without a doubt entitled to 90 per cent of the credit in making such a wonderful success of this convention, cries of enthusiasm arose from everybody, and three cheers went up for Mr. Steffes, and then three more for Mr. Meyer, the man who has helped make the Universal program, and at the same time the MOTION PICTURE NEWS so popular in this territory.

Film Men at Executive Sessions

Billy Merrill, manager of Warners' Features, Incorporated, spoke a few words and expressed his desire that the time would soon approach when film men may be admitted to all executive meetings. "Your success means ours, and if we don't work hand in hand on this thing, neither one of us will succeed."

The toastmaster then called on C. E. Van Duzee, the father of the motion picture business of the Northwest. "Van" told about the "good old days" when a two-hundred-foot subject was considered a big feature; days when film was lying all around the balcony floor.

And then followed Dick Ferris, local theatrical favorite, well known and equally liked everywhere. Mr. Ferris spoke of the time when motion pictures were a miracle, not a reality, and the traveling 10-20- and 30-companies traveled over hills and dales; over streams and wide rivers to explore countries hitherto practically unknown.

Coverly, of Duluth, amused the assembly with a "Flea" story, but "Bingo" was not there.

The next man called upon was D. G. Rodgers, treasurer of the M. P. E. A. of Minnesota. Mr. Rodgers' speech was along the same lines as the one he made during the afternoon session of the league, when he told Dr. C. B. Storrs, dramatic critic of the Minneapolis "Tribune" where to get off at. Mr. Storrs is the man who remarked that every minute he ever spent at a moving picture theatre was time wasted. Most anybody could have answered him, but Dave Rodgers is the only man who could do it right—he did.

Barnett of the Famous Players, Preller of the Eclectic, were the other film managers to be called upon, after which the big dinner was ended.

FRED S. MEYER.

"THE LAST CHORD"

(Savoia-Warners—Three Reels)

REVIEWED BY PETER MILNE

PROBABLY there is nothing which affects the human emotions more than the sight of a mother distracted over the loss of her child. The sufferings of a child will arouse great sympathy, but it is about a draw with the suffering of its mother after the child has passed out of existence. The main scenes in this picture deal with the latter case, and are carried off very well by a foreign actress, whose name is not known. Emotionalism marks the entire rendition of her part, and for that style of acting hers is excellent.



TRYING TO FORGET

Some may think the scenes in which she is seen in her raving madness are slightly too long, a little too long to create the effect they would if they were shortened. But as they stand now they are most impressive and appealing. The leading actress is given support of the same high quality.

The Savoia brand of pictures has created a name for itself in regard to beautiful photography, and this production is marked by good photography. We have seen better in the same brand of pictures, but the photographic work of these three reels is above the average. Unusual and artistic scenes and sets have been obtained, and used to good advantage. Winter scenes always show to good effect on the film as they do here, and the scenes with the bay for a background are equally as pretty.

The plot deals with the villainous revenge taken by a disappointed lover. He poisons the child of the woman he once loved. Her husband, who is a great violinist, receives a telegram, just after he has played to a large assemblage of persons, saying that his wife is distraught from the death of her child.

He returns home and finally succeeds in comforting her. She tells him the perpetrator of the deed, and it seems wholly justified when he forces the villain to a duel with him. The husband's shot is the true one.

New England Exhibitors Plan Gala Ball

Event Will Be Staged at the Boston Arena, December 2; Committees Hard at Work on the Entertainment Features—Serials Popular Throughout the Territory—Project on Foot to Organize New Hampshire Exhibitors—What Educators Are Doing with Films in New England

Special to MOTION PICTURE NEWS

Boston, Nov. 4.

THE Exhibitors' League of New England has appointed committees to take care of preparations for the second annual ball, to be held on December 2, at the Boston Arena.

Many novel entertainment ideas are being planned. The various committees are devoting a great deal of time to making the ball a huge success.

The committees are lined up as follows:

Executive committee: S. Grant, chairman; R. W. Drown, secretary; G. M. Clark, treasurer; E. H. Horstmann, H. F. Campbell, P. F. Lydon, F. J. Howard, H. L. Kincaide, C. W. Fraser, J. A. Eslow, W. H. Bradley, E. J. Farrell, H. Asher, H. I. Wasserman.

Cup committee, F. J. Howard, chairman; badge committee, P. F. Lydon, chairman; talent committee, E. H. Horstmann, chairman; entertainment committee, J. A. Eslow, chairman; ticket committee, R. W. Drown, chairman; music committee, H. I. Wasserman, chairman; publicity committee; S. Grant, chairman; refreshment committee, G. M. Clark, chairman.

Labor Dispute at Lowell

Lowell, Mass., has been the seat of a labor dispute between the Musicians' Union and the exhibitors. The union has tried to prevail upon the theatres to install an orchestra varying from four to ten pieces, according to seating capacity.

But the theatre men have been employing non-union musicians, or going without, until the union has decided that it could not force the exhibitors to change their policy.

The larger houses have not settled the question yet, but the union men are back at their old places in the straight picture houses.

Serial pictures have won a lasting supporter at the Whittenton Theatre, Taunton, Mass. Joseph C. Lamoureux was discouraged at the business outlook, when Mr. Hirsch, of the Thanouser Syndicate, Boston office, called on him and suggested that he start "The Million Dollar Mystery."

Mr. Lamoureux mailed a personal letter enclosing a herald to the families in his neighborhood. He also advertised that he would have a photograph of the audience taken on the opening night of the serial. The result of his advertising campaign was the beginning of a steady increase in patronage.

Theatre Notes and News

The Broadway Theatre, Derry, N. H., opens November 31 under the management of Kelley and Cote. This theatre is equipped with a Power's 6A, and will use Mutual service.

The Empire Theatre, Salem, Mass., has changed hands. The new owners open with Alco service, and have installed Mr. Frank Brown as house manager.

The Milford Opera House, Milford,

Mass., is playing stock along with its policy of using large feature pictures. The pictures used are Famous Players and Universal Service. This house is one of the finest in New England with a seating capacity of 1,200, and is doing a good business since Messrs. Grant and Campbell have taken it over.

The popularity of serial pictures in New England is shown in the advance bookings of the Universal "Master Key" and the Thanouser Syndicate "Zudora." Every theatre which has used the preceding serials from these exchanges has signed for the coming ones. Many New England theatres are using every serial on the market, and are satisfied with the result.

To Start League in Granite State

The following letter to Mr. W. H. Bradley, manager of the Mutual Film Exchange, will interest exhibitors throughout New England. Mr. Bean deserves all praise and support.

PASTIME AMUSEMENT COMPANY.

Franklin, N. H., Oct. 18, 1914.

Mr. W. H. Bradley,
Boston, Mass.

Dear Sir—Will you mail me your mailing list of theatres in New Hampshire. I am going to mail each manager and owner a letter and try and organize a State Exhibitors' League in this State. We have got to get together, as I am very much afraid of bad legislation for the moving picture houses in this State.

Trusting you will mail this to me at once and thanking you for the favor, I remain,

Yours respectfully,

(Signed) C. H. BEAN.

Pictures in Educational Circles

The Y. M. C. A. of Fall River is carrying on a very successful series of motion pictures Saturdays. These are in charge of Mr. H. E. Dodge, the general secretary, and are especially planned for the children. Every picture is censored, and the shows are valuable additions to the educational plans of this association.

The Women's Educational and Industrial Union of Boston, Mass., has arranged to start a Saturday morning performance of motion pictures for children at Tremont Temple. The plans are in charge of Miss Florence Lincoln, and promise to be unique and interesting. Miss Lincoln is the author of "The End of the Bridge," the successful drama which won the John Craig "Harvard Prize," and which ran for a long time at the Castle Square Theatre, Boston.

These "Saturday Mornings" will open in December, and the programs will be published at an early date.

St. Mary's Church, Cambridge, Mass., has inaugurated a weekly motion picture day, on Wednesday. Rev. Father Lydon, who has charge of these, says that the patrons like the four and five reel feature,

and he has signed up several of the best of these for the season.

The Cambridge, Mass., Y. M. C. A., has opened a regular motion picture show at its hall in the Association Building. The film "Evangeline" was shown there this week, and proved to be a drawing card. This is the first New England Y. M. C. A. to establish a regular theatre program, as a competitor of the regular picture house.

Changes at Box Office

E. L. Knight, of the new Bijou, Springfield, was in Boston this week in the interests of The New England Motion Picture Company. Mr. Knight is treasurer, and E. F. Farnsworth president of this enterprise. The plans of the company promise an interesting announcement in the near future.

The Box Office Attractions announces a change in management at its Boston office. Mr. Levin will go to Philadelphia, and Mr. Frank L. Meade, of Boston, will take charge of this office.

E. MacEvoy, formerly connected with Atsco, Inc., has joined the Phoenix Film Company. "Eddie" is well known in this territory, and has many friends who hope for his success. The Phoenix Film will handle the Sawyer releases here, and has established a very convenient and pleasant film headquarters at 129-131 Columbus avenue, Boston, Mass.

F. J. Peters, of The Phoenix Feature Film Corporation has returned from a trip to New York, where he purchased ten new high class features, among which were "The Factory Girl Magdalen," which was produced in Providence. "The Life of Shakespeare" is another release he has secured.

Lewiston Theatre Doomed

The Gem Theatre, Lewiston, Maine, will pass out of existence about January 1, 1915. The property has been sold to a mercantile firm, and will be torn down to make room for a large dry goods establishment. Mr. McCarthy has no future plans at present for the continuation of his motion picture interests. Mr. Clark, of the Huntington Avenue Theatre, Boston, Mass., is at present in Lewiston looking after the new theatre which he is building there, and which is fast nearing completion.

"Cabiria" is still running at the Tremont Temple. F. Samuels, who is handling this film in New England, reports that this picture is still drawing good sized audiences.

The Boston Opera House had motion pictures on its program for the first time in its history during the current week. The cancelling of the regular opera season allowed the opening of a high class program of pictures and music.

"READY MONEY"

(Lasky-Paramount—Five Reels)

REVIEWED BY CLIFFORD H. PANGBURN

THE stage success "Ready Money" proves to be fully as entertaining on the screen as it was behind the footlights. It is a story which is well adapted for the films because of its wide variety of scenes and its touches of comedy.

In the matter of settings, the usual advantage of the films is brought out very strongly. Both in exteriors and interiors there are some unusually fine effects. The street crowd celebrating the new year with confetti, paper ribbons and the other implements of warfare so popular on Times Square on that occasion is a novel and decidedly well done scene.



THE DYNAMITER DISCOVERED

The views in and about the mine are also effective. Another New Year scene shows the interior of a big New York restaurant, where the diners are eating and drinking the old year out. This is as good a restaurant setting as has been on the screen in some time.

The incidents of the story which take place in the Western mining town are also realistic to an unusual degree.

The cast is headed by Edward Abeles, who will be remembered by film fans for his work in "Brewster's Millions." The other players are well suited to their parts and handle them well, Theodore Roberts being particularly good as the miner, Mike Reardon.

The story concerns the adventures of a young mining engineer, who, with Mike Reardon, buys an abandoned mine from which he eventually makes a fortune. Before he meets with success, however, he has many unpleasant experiences, including an arrest as a counterfeiter's accomplice.

"THE MAN FROM MEXICO"

(Famous Players-Paramount—Five Parts)

REVIEWED BY E. J. HUDSON

THERE is a sufficient variety of comedy in John Barrymore's characterization of "The Man from Mexico" to appeal to every class of motion picture patrons.

The Famous Players Film Company, in addition to accomplishing this fact, has manifested an attention to detail in sets and the action of the story which gives it an air of quality that is above the average.

The story is unfolded in a commonsense way. Each separate unit of humorous action stands out clear and distinct, and yet is so artistically blended in the final assembling that the result is unique.

Exhibitors will find abundant advertising material in the production. John Barrymore as Mr. Fitzhew is typical of almost every married man, while his wife is true to the emotions, characteristics and suspicious of her sex in marital harness.

Fitzhew, a stock broker, takes his first lesson as the driver of his own automobile en route from his office to his home. He just escapes running down his bosom friend.

The two finish the journey together. Mrs. Fitzhew is about to spend the night with her mother, arranging the details of a trousseau for her sister. Fitzhew seizes the chance to visit a notorious cafe. Mrs. Fitzhew, returning to get her pocketbook, overhears the plot. She enlists the aid of the district attorney's nephew.

Fitzhew creates a small riot in the cafe, while Paquita, a singer, gets a photograph of Mrs. Fitzhew from the pocket of the new "well lighted" broker. Mrs. Fitzhew, with the district attorney's nephew, visits the place, hoping to confront her husband with his domestic sin. But the broker is dragged out, radiating good cheer from every pore. The place is raided, Mrs. Fitzhew is arrested, but upon her companion's pledge to the police, is permitted to go. Believing her husband to be at home, she flees to a railroad station to await morning to bear out her proposed trip to her mother's home. Fitzhew gets into a fight with a hansom cab driver, and is arrested and sentenced to thirty days on Blackwell's Island for attempting to influence the night court judge. A detective accompanies him home to prepare for the trip.

The next morning Mrs. Fitzhew arrives, and is informed by her spouse of an immediate thirty-days trip to Mexico, "for his health."

His excuse is accepted and then follows a series of well-staged incidents of a pleasing character to the end.

Humor, clean and clever, prevails. Barrymore is exceptionally good in the role of Mr. Fitzhew, and receives able support from every one of the principals. "The Man from Mexico" will provoke laughter, loud and long, wherever it is shown.

"THE BELOVED ADVENTURER" TO THE RESCUE AGAIN

AGAIN "The Beloved Adventurer" undertakes to straighten out the troubles of a worthy couple, and although the game is a dangerous one, he is eminently successful.

On the ship that is bringing him back to England he encounters a bridal couple just returning from their honeymoon. The young husband gets into the clutches of a pair of poker crooks, and is not only cleaned out of his own money, but also \$10,000 belonging to his employer.

The situation is so desperate that the heartbroken bride is about to jump overboard when Cecil saves her and hears the story. He calms the little girl down, and promises that all shall be well. Crooks are favorite "game" for the Englishman, and he not only gets all of the money back, but makes them feel that they have encountered a cyclone.



LORD CECIL TO THE RESCUE

Thus the newlyweds are made happy and Cecil adds one more number to the list of adventures.

SCREEN CLUB BALL ON THANKSGIVING EVE

THE third annual ball of the Screen Club will be held in the Hotel Astor, New York City, on Thanksgiving Eve, November 25. Tickets of admission for gentleman and lady will be five dollars. The boxes on the lower tier will be sold for seventy-five dollars, and those on the upper tier are expected to bring fifty dollars.

The committee of arrangements are: King Baggot, Jacob Gerhardt, George Blaisdell, William Barry, Herbert Brenon, Joseph Farnham and Jules Bernstein.

Due to the efforts of "Joe" Farnham the ballroom of the Aster Hotel was secured for the occasion.

INTERESTING FILM REVIEWS

PRODUCTIONS FROM ALL PROGRAMS

GENERAL FILM PROGRAM

"All for Business." (Biograph. Mon., Nov. 2.)—A broker neglects his wife because of his interest in his business. She has a chance to teach him a forceful lesson which results in happiness and forgiveness on both sides. The principals are Ivan Christy and Augusta Anderson. Suitable for neighborhood theatre or one using mixed programme.

"Masks and Faces." (Biograph. Two reels. Tues., Nov. 3.)—A costume play of the eighteenth century founded on Charles Reade's novel, "Peg Woffington." A married man makes love to an actress. A jealous rival actress sends the wife to a party being given by the husband for the other woman. As the wife loves her husband and the actress also loves him, complications follow. Suitable for any theatre not confining itself to contemporary pictures.

"Countess Sweedie." (Essanay. Mon., Nov. 16.)—A good Sweedie comedy in which Sweedie disguises herself as a countess to attend a fashionable ball. She gets away with it, until the real countess appears. After a rough and tumble fight the police arrest her and she spends the night in jail. A lot of comedy is developed in the "hash-house" where Sweedie works at the start of the picture.

"The Servants' Question." (Essanay. Tues., Nov. 17.)—Helen, an heiress, in order to solve the servants' question, takes a position as Mrs. Newlyrich's maid. A rich baron becomes infatuated with the supposed maid, and obtains work in the same house as chef. That evening he cooks an uneatable dinner at which Lord and Lady Montford are guests. He is discharged, but in the excitement that follows, Lord and Lady Montford recognize the maid and the chef as old friends, and the four depart for a square meal.

"The Fable Proving that Spongers Are Found in a Drug Store." (Essanay. Wed., Nov. 18.)—George Ade very cleverly shows the trials of a corner druggist, upon whom the whole neighborhood imposes, while his cash register sleeps. You can't blame the poor druggist for taking a good slice of profit from the occasional live ones who come in to really buy something.

"A Horse on Sophy." (Essanay. Nov. 19.)—An unusually funny Sankeville comedy. Sophy will marry the man who owns the better horse. Slippery Slim and Mustang Pete each try to win her by securing what they think is the best horse in town. Both are stung in the deal, one procuring a horse that won't budge an inch, and the other getting stuck with a horse that insists upon running backwards instead of forwards. Many ludicrous situations are developed and the antics of the two horses make a very funny piece of work.

"Broncho Billy's Scheme." (Essanay. Sat., Nov. 21.)—A Western drama, in which Broncho Billy rescues a girl from a band of outlaws. The rescue is the result of a very clever idea, and the whole play is excellently acted and produced.

"If I Were Young Again." (Selig. Two reels. Mon., Nov. 16.)—A picture fantasy by Gilson Willetts. An aged professor discovers a vial of fluid among the bandages of an Egyptian mummy which brings back to him his youth and transforms him into a young man. Nothing but misfortune, however, comes with the return of his youth. He burns the remaining fluid, and the fumes have the opposite effect. Much to his joy, he is restored to his former condition, and happily takes his old life where he had left off. A splendid production well acted by Charles Wheelock and Lillian Heyworth.

"The Sheriff's Reward." (Selig. Tues., Nov. 17.)—Another of the Tom Mix very high-grade cowboy dramas, in which he, as the sheriff, daringly rescues Rose, a pretty young ranch owner, from a band of cattle rustlers, by whom she had been kidnapped. They are married and their friends start them off on their honeymoon in typical cowboy fashion.

"The Broken X." (Selig. Wed., Nov. 18.)—A "Blue Flame" detective drama, whose plot is

a trifle confusing. Secret service agents cleverly trace a daring bank robbery to an old gang which was supposedly broken up twenty years ago. The mayor of the town and two well-known citizens are implicated and sent to prison for long terms.

"The Mysterious Black Box." (Selig. Fri., Nov. 20.)—A farce comedy with a clever idea and many laughs. The boss is in a compromising position with his stenographer. Bill, a lazy employee, appears at this moment carrying a black lunch box which the boss mistakes for a camera. As a result, the boss is unusually nice to his hitherto mistreated wife and to Bill, much to the surprise of both. Many hours of worry for the boss ensue, until he discovers the truth, but by that time Bill has married the boss's daughter.

"Her Sacrifice." (Selig. Sat., Nov. 21.)—An artistically produced drama of a fishing village with a star cast, including Kathlyn Williams, Wheeler Oakman, Charles Clary, Frank Clark and Gertrude Ryan. A fisherman's sweetheart gives him up and persuades him to do the manly thing by marrying a little innocent girl that he had wronged.

"The Mountain Law." (Lubin. Two reels. Wed., Oct. 28.)—A wild feud between two families in the mountains of the South is the basis of this story. There are some good mountain scenes and several exciting bits of fighting. In the cast are Louise Huff, Arthur Matthews, Edgar Jones and James Daly.

"The Wolf's Daughter." (Lubin. Two reels. Thurs., Oct. 29.)—The convent-bred daughter of a crooked promoter learns of his dishonesty in time to save a friend from his methods. A sordid story, but fairly interesting. The ending is unhappy. Velma Whitman plays the lead.

"Thumb Prints and Diamonds." (Lubin. Fri., Oct. 30.)—A thief posing as a diamond expert steals a valuable stone, and by a fake thumb print directs suspicion on an innocent man. Of course he fails in the end. Some good scenes showing the thief fighting with his victim. Rosemary Theby and Harry C. Myers head the cast.

"The Soubrette and the Simp." (Lubin. Sat., Oct. 31.)—On the same reel with "An Interrupted Nap." An amusing comedy of a cowboy who breaks into the theatrical game for a brief time, and goes broke.

"An Interrupted Nap." (Lubin. Sat., Oct. 31.)—On the same reel with "The Soubrette and the Simp." A cartoon picture by Vincent Whitman.

"The Temple of Moloch." (Edison. Sun., Nov. 25.)—A picture taken in co-operation with the American Society for the Prevention of Tuberculosis, showing the different means of preventing the spread of the disease. The story deals with a pottery, whose proprietor refuses to make any changes in the construction of his buildings or alter the working conditions of his employees as suggested by the society's doctor. By his own children being taken down with the dread disease, and afraid of contracting it himself, he is finally made to see the error of his ways and makes the required alterations. The children recover and in the closing scene everybody is healthy, happy and contented with the new order of things. Directed by Wm. West.

"The Last of the Hargraves." (Edison. Wed., Nov. 28.)—A revelation in drama releases, in that it treats of a rather hackneyed subject in a novel way. The story of the feud is brought on by a series of scenes that lead up to the story itself. Gertrude McCoy in the role of the mountain lassie, Virginia Hargrave, who has sworn to carry on the feud, displays her wonderful emotional acting when she thinks she has killed her lover, Buckner. Robert Connes plays the part of Buckner. The feud is ended when Virginia becomes the bride of Buckner. A good number with clear photography. Directed by John H. Collins.

"His Chorus Girl Wife." (Edison. Mon., Nov. 23.)—A Thanksgiving story of the familiar type. Marriage against the father's wishes, sorrow, accidental meeting and Thanksgiving dinner in the old home. Well acted and more original than most such stories.

"Wood B. Wedd Goes Snipe Hunting." (Edison. Mon., Nov. 30.)—The familiar snipe bunting trick which is worked on so many new boys in summer camps is tried on Wood B. Wedd, but the tables are turned, thanks to the assistance of the girl he is courting. Some excellent comedy and a number of good photographic effects make this a good film. William Wadsworth and the usual cast are seen.

"A Gypsy Madcap." (Edison. Tues., Nov. 24.)—Some gypsy scenes of more realism than usual add to the interest of this picture, which is founded on a story by Mrs. Wilson Woodrow. Mabel Trunelle as the heroine does some effective acting. A gypsy girl falls in love with a man not of her people, and finds that there are many troubles in her way.

UNIVERSAL PROGRAM

"For the People." (Victor. Two reels. Fri., Nov. 20.)—This picture is built around the Workmen's Compensation Act which was recently passed in the State of Ohio. The Governor of that State and members of the Senate appear in a few scenes of the picture. The story is one of love and politics, very entertaining and played by Matt Moore, Dorothy Phillips and Howard Crampton in the leading roles.

"The Yellow Streak." (Eclair. Two reels. Wed., Nov. 11.)—A good story of a prize fighter who leaves the ring for the love of his sweetheart. He enters the fire department, and although branded as a coward by his friends, proves his courageousness by rescuing the girl from a burning building. Later he enters the ring again to procure enough money to send the girl to the country and she forgives him. The plot may be conventional, but is entertaining enough.

"The Ghost of the Mine." (Eclair. Wed., Nov. 18.)—A pathetic story told by the oldest inhabitant of a Western town to the new owner, of an equally aged mine. In the story an Indian girl, who was the victim of a Spaniard, is the central figure. This is a Western that is different.

"A Friend in Need." (Eclair. Split reel. Sun., Nov. 22.)—On the same reel with "Our Beloved Country." Simple story of a little girl who in ignorance that she is doing wrong, robs to save her ill mother. She is arrested, takes the policeman to her home, but her mother has died in the meantime. The policeman adopts her. Clara Horton is the girl in this pleasing offering.

"Our Beloved Country." (Eclair. Split reel. Sun., Nov. 22.)—On the same reel with "A Friend in Need." A unique sketch of the rapid growth of the United States, from the time of Columbus until the present. Interesting and instructive.

"The Battle of the Nations." (Joker. Sat., Nov. 21.)—The European war seems too serious a subject to burlesque; however, this picture is funny in parts, and will not give offense. Three Frenchmen and three Germans have quite a few scraps, due to the fact that one from each family loves the other. All ends well. A large cast appears with some of the stars of the company, including William Franey.

"Treasure Train." (Imp. Two reels. Mon., Nov. 16.)—A well-developed railroad story in which King Baggot and Arline Pretty lead a good cast. Thrilling situations keep the observer in continual suspense.

"His Uncle's Will." (Rex. Two reels. Thurs. Nov. 19.)—A conventional story, but well played by Robert Leonard and Ella Hall. Fine moments of comedy appear throughout. His uncle's will specifies that he is to marry a certain girl, and after refusing to have the affairs of his heart arranged, he falls in love with her, while he is working as a chauffeur and she is studying at school.

"The Phantom Cracksmen." (Victor. Mon., Nov. 16.)—Directed by Walter Edwin with Mary Fuller and Charles Ogle leading the cast. The story seems rather unfinished. The Cracksmen turns out to be a woman. She promises her captor to reform, but is shot by the police, while in bidding.

Cosmofotofilm Co

"Where the Real Features Come From"

"ENGLAND EXPECTS—"

An Up-to-the-Minute War Story—Contains Splendid Child-Acting—In Two Parts—Just Shown at the Million Dollar Strand Theatre, New York

For Exclusive Rights, Address us at

World's Tower Bldg., 110 W. 40th St., New York



London Film Co.
(Trade Mark)

"Dot's Chaperone." (Sterling. Thurs., Nov. 5.)—Max Asher dresses as the chaperone and is employed by his sweetheart's father. He finally gets rid of all the other suitors and marries the girl. Amusing.

"The Turn of the Tide." (Imp. Two reels. Mon., Nov. 2.)—Shearing this picture of its frills it narrows down to the old tale of the lover unwelcomed by the father of the girl; but added incidents cause it to appear new and refreshing. In the final reel King Baggot, who plays the leading male part, rescues Arline Pretty from the water. A following scene clears the man in the eyes of the father, and he readily consents to his daughter's marriage.

"The Bachelor's Baby." (Rex. Sun., Nov. 22.)—An excellent comedy-drama with Herbert Rawlinson and Beatrice Van playing the leads. How a childish prank reunited two lovers, long separated, because of the disgrace of the girl's father, is the theme, and is handed cleverly by the two principals.

"When Lizzie Got Her Polish." (Nestor. Fri., Nov. 20.)—The girl from the Golden West on her arrival in college creates an uproar both in that place and among the audience. Her pranks are side-splitting, and because of them she is ignored by the rest of the girls; but when a burglar attempts to rob the school she proves his match and wins their gratitude. Victoria Forde and Bess Meredith are the principals.

"His Night Out." (Joker. Wed., Nov. 18.)—Ernest Shields and Betty Shade are the lovers in this side-splitting comedy. After a night out Ernest is quite the worse for wear. He dreams of the Stone Age, when force ruled humanity, and when he awakes he enters his sweetheart's house in the dead of the night, and forces her father to give his consent. Shields plays the drunkard without giving offense, and his antics are uproarious.

MUTUAL PROGRAM

"The Stolen Masterpiece." (American. Wed., Nov. 11.)—A wealthy young clubman proves his worth to the girl he wishes to marry by solving the mysterious disappearance of a valuable painting stolen from her father. In an exciting scene he thwarts the plan to replace the original painting by a copy. This is an interest-holding drama, well acted by Ed. Coxen and Winifred Greenwood, as principals.

"Motherhood." (Beauty. Tues., Nov. 10.)—A very artistically produced, semi-allegorical picture with a moral. The rebelliousness of a young wife against motherhood is conquered by a dream in which she sees the awful consequences of bringing a child into the world, who is unwelcome. This rather delicate theme is so beautifully dealt with that it will not prove offensive to the most prudish. The vivacious Margarita Fisher plays the part opposite Harry Pollard particularly well. Kathie Fisher makes a very charming little Cupid.

"Max's Money." (Royal. Sat., Nov. 7.)—Louis Simon again in a part which is hardly worthy the name of comedy. He inherits a fortune and the lawyer has a hard time reaching him in order to inform him of his good luck, as he thinks the law is after him.

"The Tear That Burned." (Majestic. Two Reels. Sun., Nov. 8.)—A story woven about crooks that is so far out of the ordinary that it appears as new. Lillian Gish reappears on the screen, after a long absence, in the title role. She is ably assisted by W. E. Lowery and John Dillon. How the innocent country girl left her home because of the cruelty of her father, and

how she became the victim of a city thief, who used her as a tool, and how she finally is adopted by a respectable woman is the plot. It is most excellently produced by Jack O'Brien. A picture that is worthy the name of "feature."

"A Woman Scorned." (Reliance. Two Reels. Sat., Nov. 7.)—Another crook story played by Eugene Pallett, Sam De Grasse, Jack Flynn and Mary Alden. The detective and a reporter working on the trail of two crooks is the theme. They are aided by a woman, cast off by one of the crooks. A well constructed offering directed by Jack Adolph.

"The Stolen Masterpiece." (American. Wed., Nov. 11.)—With the help of a servant thieves steal a rare painting, copy it and return the copy. They are discovered, and the original recovered by the fiancée of the owner's daughter, who is thus restored to favor. Some good scenes and acting add to the interest.

"A Slice of Life." (American. Two reels. Mon., Nov. 9.)—A novelist loses his memory as the result of an accident. He falls in love with a girl who collaborates with him on some new stories, but she accidentally discovers who he is, and restores him to his wife. Winifred Greenwood is the principal. There are a number of attractive and realistic scenes.

"The Miner's Peril." (Reliance. Wed., Nov. 4.)—An exciting adventure story in which two Mexicans seek revenge for their dismissal by attempting the life of a mine superintendent. He saves himself by pulling a knife from his pocket with his teeth, and then opening it by the same means, while bound hand and foot. This is very well done and decidedly clever. His wife also helps to save him in a novel way.

"His Musical Career." (Keystone. Saturday, November 7.)—Again Charles Chaplin appears, this time as a piano mover. It need not be said the film is an excellent comedy. Chaplin introduces some new stunts, which are most humorous.

"'Curses!' They Remark'd." (Keystone. Thurs., Nov. 5.)—Chester Conklin and a gentleman who assumes the role of his father play the parts of two dire villains. They attempt to swindle an heiress of her fortune, but they reckon without the hero, who comes to the rescue in the nick of time. Very funny.

"Casey's Vendetta." (Komic. Sun., Nov. 1.)—Some good slapstick stuff, and also an excellent burlesque of the vendetta type of film. Casey flirts with Anita, a fruit stall keeper, and thereby arouses the ire of Antone, who keeps another stall across the way. Worth while showing. Fay Tincher plays the part of Anita.

"Our Mutual Girl, No. 42." (Reliance. Mon., Nov. 2.)—Margaret does some shopping at a large department store. Views from the store are shown. Next she visits the head of the Society for the Prevention of Cruelty to Animals. She is so much interested in the stray dogs at the Society's pound that she at once adopts three of them. On the way home she has a cruel driver of a worn-out old horse arrested. Ralph has opposed her adoption of the dogs, but is won over at the sight of them. As the reel ends Ralph is evidently about to propose to Margaret.

"Paid With Interest." (Majestic. Two reels. Sun., Nov. 1.)—A weak story very well acted by a cast headed by Mae Marsh and Robert Harron. Miss Marsh appears to much advantage in scenes requiring a wide range of acting. A poor girl jilts a telephone lineman to marry a man of wealth. By cutting a phone wire during a crisis on the stock market the lineman causes his rival to lose his fortune. The girl marries him in spite

of this. Her husband soon wins back his money, but becomes unfaithful. The lineman is present when he dies, and saves the wife's illusions as to her husband, although it costs him what chance he may have had of winning her. Thus he pays for his treachery.

"False Pride." (Majestic. Tues., Nov. 3.)—A good moral to this picture, which is acted well by F. A. Turner as the father, Signe Auen as the extravagant daughter, who finally awakes to the evil of her ways when her father becomes blind, and Elmer Clifton as the girl's lover.

"Shep's Race with Death." (Thanouser. Sun., Nov. 1.)—A pretty little drama centering around Shep, the Thanouser dog, and the two twins. The denouement seems rather weak, as the rescue that Shep effects is marred by poor cutting of the film. Otherwise very good and pleasing.

"The Turning of the Road." (Thanouser. Two reels. Tues., Nov. 3.)—A crook story a little too long to warrant the best interest. The crook's stepdaughter is led to reform through the right thinking rector. Muriel Ostriche is the girl. The scenes are especially beautiful and are supported by photography of the highest order.

"The Dead Line." (Princess. Fri., Oct. 30.)—A rather pointless slapstick comedy in which Boyd Marshal leads the cast. A considerable amount of running and falling occurs when the rube army and a like police force enter the scenes. The picture will cause a few laughs.

WARNER'S FEATURES

"Rainbow's End." (Miller Brothers. Three reels.)—A Western that contains slightly too much unnecessary riding, but otherwise is quite good. The reformed cattle rustler is the main character, and his efforts to live straight in another State with his wife and children are finally rewarded. His old partner attempts to bring him back to crooked ways, but is frustrated by his wife, who shoots him.

"Mexican Hatred." (Miller Brothers. Three reels.)—An order is issued by the commander of the fort that all Mexicans caught spying are to be shot. One is caught and shot by the commander's son. Later he is captured by the Mexican's wife, who knocks him unconscious with a stone. His memory leaves him and thereafter he is brought up to hate the Americans. He is sent to spy on the fort and is caught. He is about to be shot when his identity is made known by the Mexican woman. He is saved and later regains his memory. This is an exciting release, containing some good riding, fast action and an entertaining plot.

"The Terror of a Great City." (Mittenthal. Three reels.)—A regular old-fashioned melodrama. The dire villain, the misrepresented hero, and the hero's tramp friend are all important characters. Besides this, most of the principals are army officers, ostensibly of the German army. The plot is absorbing, acted fairly well, but in some scenes the signs of poor producing are quite evident. "The Terror" mentioned in the title is an earthquake, which, in true melodramatic style, kills the villain and all his confederates.

"A Mountain Goat." (Albuquerque.)—A good, funny offering laid in beautiful surroundings. The unwelcome gentleman visits a hotel on the top of a lofty mountain where a number of girls are vacationing, with their lovers in a nearby camp. This man is always in the way, and finally is caught in a very compromising situation with an old maid. She claims him as her husband, but he makes good his escape the next day.

What Do You Need?

LISTING IN THE BUYERS' GUIDE, FOR NAME AND ADDRESS, INCLUDING ONE YEAR'S SUBSCRIPTION TO MOTION PICTURE NEWS—\$2.00 A YEAR, CASH IN ADVANCE. FREE TO ADVERTISERS USING \$100.00 OR MORE WORTH OF DISPLAY SPACE DURING THE YEAR. ADDRESS ADVERTISING DEPARTMENT

ADVERTISING NOVELTIES

Philip Hano, 806-810 Greenwich St., New York.

ANNOUNCEMENT SLIDES

Niagara Slide Co., Lockport, N. Y.

ASBESTOS BOOTHS

Sharlow Bros., 442 W. 42nd St., New York.

CLEANING AND RENOVATING FILM

Film Redeveloping Co. of America, 145 W. 45th St., New York.

Multicolor Film Improving Co., Inc., 15 E. 26th St., New York.

COSTUMERS

Miller-Costumier, 236 South 11th St., Philadelphia, Pa.

DEVELOPING TANKS

A. J. Corcoran, Inc., 9½ John St., New York.

ELECTRIC LIGHTING SETS

The Chas. A. Strelinger Co., Box P-2, Detroit, Mich.

FILMS

(Manufacturers, Dealers and Renters)

American Film Mfg. Co., Chicago, Ill.

Thomas A. Edison, Inc., 275 Lakeside Ave., Orange, N. J.

Essanay Film Mfg. Co., First National Bank Bldg., Chicago, Ill.

General Film Co., 200 Fifth Ave., New York.

George Kleine, 166 N. State St., Chicago, Ill.

Lubin Mfg. Co., Philadelphia, Pa.

G. Melies, 204 E. 38th St., New York.

Mutual Film Corp., 71 W. 23rd St., New York.

New York Motion Picture Corp., Longacre Bldg., New York.

Pathé Freres, 1 Congress St., Jersey City, N. J.

Renfax Film Co., Inc., 110 W. 40th St., N. Y.

Selig Polyscope Co., Chicago, Ill.

Thanouser Film Corp., New Rochelle, N. Y.

Universal Film Mfg. Co., 1600 Broadway, N. Y.

FILM ACCESSORIES

Berlin Aniline Works, 213 Water St., New York.

FILM TITLES, PRINTING, DEVELOPING, ETC.

Commercial Motion Pictures Co., Inc., 220 W. 42nd St., New York.

Centaur Film Co., 670-682 Ave. E, Bayonne, N. J.

Evans Film Mfg. Co., 412-22 W. 216th St., at Broadway, New York.

Gunby Bros., Inc., 145 W. 45th St., New York.

Industrial Moving Picture Co., 223-233 W. Erie St., Chicago.

Standard Motion Picture Co., 5 S. Wabash Ave., Chicago.

Standard Filmprint Corp., 120 School St., Yonkers, N. Y.

FILM REELS

Lang Mfg. Works, Olean, N. Y.

Taylor-Shantz Company, 224 Mill St., Rochester, N. Y.

FURNITURE AND FURNISHING ON RENTAL

William Birns, 103-105 West 37th St., New York.

FEATURE FILMS

Alco Film Corp., 218 W. 42d St., New York.

Alliance Films Corp., 126 W. 46th St., New York.

Albuquerque Film Mfg. Co., Inc., 406 Court St., Los Angeles, Calif.

All Star Feature Corp., 220 W. 42d St., New York.

Ambrosio American Co., 15 E. 26th St., New York.

Bosworth, Inc., 640 N. Olive St., Los Angeles, Cal.

Box Office Attraction Film Rental Co., 130 W. 46th St., New York.

A. Blinkhorn, 110 W. 40th St., New York.

California Motion Picture Corp., San Francisco, Cal.

Cosmofotofilm Co., 110 W. 40th St., New York.

Cosmos Feature Film Corp., 126-130 W. 46th St., New York City.

Direct-From-Broadway Features Co., 46 W. 24th St., New York.

Eclair Film Co., 126 W. 46th St., New York.

Eclectic Film Co., 110 W. 40th St., New York.

Excelsior Feature Film Corp., Inc., 110 W. 40th St., New York.

G. W. Feature Film Corp., 145 W. 45th St., N. Y.

Features Ideal, 126 W. 46th St., New York.

Famous Players Film Co., 213-229 W. 26th St., New York.

Films Lloyds, Inc., 220 W. 42nd St., New York.

General Film Co., 200 Fifth Ave., New York.

General Feature Film Co., 313 Mallers Bldg., Chicago, Ill.

Gaumont Co., 110 W. 40th St., New York.

Greene's Feature Photo Plays, Inc., 110 W. 40th St., New York.

W. W. Hodgkinson, 110 W. 40th St., New York.

Imperial Motion Picture Co. of N. Y., Inc., 1476 Broadway, New York.

Inter-Continent Film Co., 110 W. 40th St., N. Y.

George Kleine Attractions, 166 N. State St., Chicago, Ill.

New York Office: 1476 Broadway.

Jesse L. Lasky Feature Play Co., Longacre Theatre, New York.

Life Photo Film Corp., 220 W. 42nd St., N. Y.

Mecca Feature Film Co., Inc., 126 W. 46th St., New York.

Mohawk Film Co., Times Bldg., New York.

Oz Film Mfg. Co., Santa Monica Blvd., Los Angeles, Cal.

Paramount Pictures Corp., 110 W. 40th St., N. Y.

Phoenix Feature Film Corp., 129-131 Columbus Ave., Boston, Mass.

Photo Play Production Co., 220 W. 42nd St., N. Y.

Picture Playhouse Film Co., 110 W. 40th St., New York.

Playgoers Film Co., Lyric Theatre, New York.

Popular Plays and Players Co., 1600 Broadway, New York.

Progress Film Co., 110 W. 40th St., New York.

Progressive Motion Pictures Corp., Times Bldg., New York.

Ramo Films, Inc., Columbia Theatre Bldg., N. Y.

Roland Feature Film Co., 145 W. 45th St., N. Y.

A. H. Sawyer, Inc., 1600 Broadway, New York.

Select Photo Play Producing Co., Inc., 71 W. 23rd St., New York.

Sterling Camera & Film Co., 145 W. 45th St., New York.

Solax Co., Fort Lee, N. J.

The Masterpiece Film Mfg. Co., 1111 Van Nuys Bldg., Los Angeles, Cal.

The Photoplay Productions Releasing Co., 37 S. Wabash Ave., Chicago, Ill.

Union Features, 126 W. 46th St., New York.

Universal Film Mfg. Co., 1600 Broadway, N. Y.

University Films, Inc., 110 W. 40th St., N. Y.

Edw. H. Wagner, Agt., Dania Biofilm Co., 38 Park Place, New York.

World Film Corporation, 130 W. 46th St., N. Y.

Warner's Features, Inc., 130 W. 46th St., N. Y.

LANTERN SLIDE MATS AND REEL BANDS

Lantern Slide Mat Co., 149 W. 35th St., N. Y.

LABELS

Every Ready Roll Label Co., 203-7 W. 40th St., New York City.

LIGHTING PLANTS

Cushman Motor Works, Lincoln, Neb.

LOBBY PHOTOS

The Wyanoak Pub. Co., 136 W. 52nd St., N. Y.

MOTION PICTURE MACHINES AND SUPPLIES

Amusement Supply Co., 160 E. North Fifth Ave., Chicago, Ill.

Behrend Motion Picture Supply House, 440 Fourth Ave., New York.

Calehuff Supply Co., 1301 Race St., Philadelphia, Pa.

Enterprise Optical Co., 568 W. Randolph St., Chicago, Ill.

Lears Theatre Supply Co., Sam Lears, Prop., 509 Chestnut St., St. Louis, Mo.

Oliver Moving Picture Supply Co., 647 Euclid Ave., Cleveland, O.

Picture Theatre Equipment Co., 21 E. 14th St., New York.

Precision Machine Co., 317 E. 34th St., N. Y.

Nicholas Power Co., 90 Gold St., New York.

The Phantoscope Mfg. Co., Washington, D. C.

Sweeley's Photo Supply House, 514-516 Erie Ave., Renova, Pa.

Williams, Brown & Earle, Inc., 916-918 Chestnut St., Philadelphia, Pa.

MOTION PICTURE APPARATUS

Burke & James, Inc., 240-258 E. Ontario St., Chicago, Ill.

MUSICAL INSTRUMENTS

American Photo Player Co., 62 W. 45th St., N. Y.

Rudolph Wurlitzer Co., Cincinnati, O.

OPERA CHAIRS

The Hardesty Mfg. Co., Canal Dover, Ohio.

Steel Furniture Co., Grand Rapids, Mich.

POSTER AND PICTURE FRAMES

Menger & Ring, 442 W. 42nd St., New York.

PIPE ORGANS

Henry Pilcher's Sons, 914-920 Mason Ave., Louisville, Ky.

M. P. Moller, Hagerstown, Md.

PROJECTION LENSES

Bausch & Lomb Optical Co., 569 St. Paul St., Rochester, N. Y.

POSTERS

The Morgan Lithograph Co., Cleveland, Ohio.

RAW FILM

Eastman Kodak Co., Rochester, N. Y.

Celluloses Planchon, Inc., 75 Fifth Ave., N. Y.

David Horsley, 1600 Broadway, New York.

Raw Film Supply Co., 15 E. 26th St., New York.

REWINDERS AND GENERAL SUPPLIES

L. C. Smith Co., Schenectady, N. Y.

SCREENS

Atsco, Inc., 218 West 42nd St., New York.

Day & Night Screens, Inc., 110 W. 40th St., N. Y.

Mirror Screen Co., Inc., Shelbyville, Ind.

STEEL FILM EQUIPMENT FOR EXCHANGES AND MFERS.

Columbia Metal Box Co., 226-228 E. 144th St., New York.

TICKETS—ROLL AND COUPON

Rees Ticket Co., 400 S. 10th St., Omaha, Neb.

THEATRE LOBBY FRAMES AND FIXTURES

Newman Mfg. Co., 715 Sycamore St., Cincinnati, O.

UNIFORMS

Fechheimer Bros., Union-made Uniforms, Cincinnati, O.

VENTILATION, COOLING AND HEATING

Typhoon Fan Co., 1544 Broadway, New York.

Record of Current and Coming Releases

GENERAL FILM PROGRAM

RELEASES OF THE WEEK

Monday, November 2, 1914.

BIOGRAPH—All for Business, D., 997.....	16331
EDISON—The New Partner, D., 1000.....	16337
ESSANAY—The Laundress, C., 1000.....	16338
KALEM—His Inspiration, D., 2000.....	16333
LUBIN—A Partner to Providence, Beloved Adventurer Series No., D., 1000.....	16340
SELIG—Rosemary, That's for Remembrance, D., 2000.	16334
SELIG—Hearst-Selig News Pictorial No. 71, N., 1000..	16338
VITAGRAPH—The Mystery of Brayton Court, D., 1000	16336

Tuesday, November 3, 1914.

BIOGRAPH—Masks and Faces, D., 2073.....	16349
COLUMBUS—A Twisted Affair, C., 1000.....	16347
EDISON—Shorty, D., 1000.....	16340
ESSANAY—Fires of Fate, D., 1000.....	16342
KALEM—Lizzie, the Life Saver, C., 1000.....	16348
LUBIN—A Boomerang Swindle, C., 1000.....	16346
SELIG—The Telltale Knife, D., 1000.....	16343
VITAGRAPH—On the Stroke of Five, D., 2000.....	16244

Wednesday, November 4, 1914.

EDISON—Jenks and the Janitor, C., 500.....	16351
Buster Brown Picks Out the Costumes, C., 500.	
ESSANAY—The Fable of "How Uncle Brewster Was Too Shifty for the Tempter," C., 1000.....	16354
KALEM—The Prison Stain, D., 2000.....	16352
LUBIN—The Sorceres, D., 2000.....	16357
SELIG—"C. D.," D., 1000.....	16356
VITAGRAPH—The Evolution of Percival, C., 1000....	16355

Thursday, November 5, 1914.

BIOGRAPH—Butterflies and Orange Blossoms, C., 998	16359
ESSANAY—Slippery Slim and the Impersonator, C., 1000	16360
LUBIN—The Stolen Yacht, D., 2000.....	16361
SELIG—Hearst-Selig News Pictorial No. 72, N., 1000..	16364
VITAGRAPH—The Choice, D., 1000.....	16263

Friday, November 6, 1914.

BIOGRAPH—A Regular Rip, C., 476.....	16373
Getting the Sack, C., 523.....	
EDISON—The Pines of Lorey, D., 2000.....	16365
ESSANAY—His Dearest Foes, D., 2000.....	16367
KALEM—The Indian Suffragettes, C., 1000.....	16366
LUBIN—Love Triumphs, D., 1000.....	16372
SELIG—No Wedding Bells for Her, C., 1000.....	16370
VITAGRAPH—Thanks for the Lobster, C., 1000.....	16371

Saturday, November 7, 1914.

BIOGRAPH—The Dole of Destiny, D., 996.....	16380
EDISON—Getting to the Ball Game, C., 1000.....	16374
ESSANAY—Broncho Billy's Mission, D., 1000.....	16375
KALEM—The Men in the Vault, D., 1000.....	16379
LUBIN—Kidnapping the Kid, C., 400.....	16376
The Honor of the Force, C., 600.....	
SELIG—The Losing Fight, D., 1000.....	16381
VITAGRAPH—In the Land of Arcadia, D., 2000.....	16377

RELEASES OF NEXT WEEK

Monday, November 9, 1914.

BIOGRAPH—A Better Understanding, D., 1000.....	16382
EDISON—With Slight Variations, C., 1000.....	16388
ESSANAY—Sweedie the Trouble Maker, C., 1000.....	16390
KALEM—The Riddle of the Green Umbrella, D., 2000..	16383
LUBIN—Lord Cecil Plays a Part, Beloved Adventurer Series, D., 1000	16391
SELIG—When His Ship Came In, D., 2000.....	16385
SELIG—Hearst-Selig News Pictorial No. 73, N., 1000..	16389
VITAGRAPH—Miss Tomboy and Freckles, C., 1000...	16387

Tuesday, November 10, 1914.

BIOGRAPH—The New Magdalen, D., 1982.....	16400
COLUMBUS—A Family Intermingle, C., 500.....	16398
Oh! What a Dream, C., 500.....	
EDISON—The Heritage of Hamilton, D., 1000.....	16392
ESSANAY—Within Three Hundred Paces, D., 1000...	16393
KALEM—The Widow's Might, C., 1000.....	16399
LUBIN—Butt-ing In, C., 400.....	16397
A Bargain Table Cloth, C., 600.....	
SELIG—The Ranger's Romance, D., 1000.....	16394
VITAGRAPH—The Senator's Brother, D., 2000.....	16395

Wednesday, November 11, 1914.

EDISON—Andy Falls in Love, Adventure of Andy, C., 1000	16402
ESSANAY—Three Boiled Down Fables, C., 1000.....	16405
KALEM—A Midnight Tragedy, D., 2000.....	16403
LUBIN—The Quack, D., 2000.....	16408
SELIG—Peggy, of Primrose Lane, D., 1000.....	16407
VITAGRAPH—In Bridal Attire, C., 1000.....	16406

Thursday, November 12, 1914.

BIOGRAPH—The Fleur-de-lis Ring, D., 998.....	16410
ESSANAY—Sophie and the Man of Her Choice, C., 1000	16411
LUBIN—In the Hills of Kentucky, D., 2000.....	16412
SELIG—Hearst-Selig News Pictorial No. 74, N., 1000..	16415
VITAGRAPH—Lola, the Rat, D., 1000.....	16414

Friday, November 13, 1914.

BIOGRAPH—Life's Stream, D., 1000.....	16424
EDISON—A Question of Identity, D., 2000.....	16416
ESSANAY—The Prince Party, D., 2000.....	16418
KALEM—Ham, the Piano Mover, C., 1000.....	16420
LUBIN—The Trap, D., 1000.....	16423
SELIG—Cupid Turns the Tables, C., 1000.....	16421
VITAGRAPH—The Rock Road of Love, C., 1000.....	16422

Saturday, November 14, 1914.

BIOGRAPH—His Wife's Pet, C., 477.....	16431
The Deadly Despatch, C., 521.....	
EDISON—The Everlasting Triangle, D., 1000.....	16425
ESSANAY—Broncho Billy's Decision, D., 1000.....	16426
KALEM—Helen's Sacrifice, First Episode of the Haz- ards of Helen, D., 1000.....	16430
LUBIN—Beating the Burglar, C., 400.....	16427
Magazine Cooking, C., 600.....	
SELIG—The Fatal Note, C., 1000.....	16432
VITAGRAPH—Ann the Blacksmith, D., 1362.....	16428

Day and Date	Titles of Films Booked	Release Date	Brand	No. Reels	Review appears in MOTION PICTURE NEWS of		Posters Used and Size	Regular or Special	Cost	Advertising Used: Newspapers, heralds, slides, photographs, window cards	Weather	Total Admissions	
					Issue	Page						Matinee	Night
MONDAY													
											Remarks		
TUESDAY													
											Remarks		
WEDNESDAY													
											Remarks		
THURSDAY													
											Remarks		
FRIDAY													
											Remarks		
SATURDAY													
											Remarks		
SUNDAY													
											Remarks		

RECORD OF CURRENT AND COMING RELEASES — Continued

UNIVERSAL PROGRAM

RELEASES OF THE WEEK

Monday, November 2, 1914.

IMP—The Turn of the Tide, D., 2000.....	4204
STERLING—The Wall Between, C.....	4207
VICTOR—Mary Fuller in His Big Chance, D.....	4206

Tuesday, November 3, 1914.

CRYSTAL—They Didn't Know, C.....	4211
GOLD SEAL—The Trey O' Hearts, No. 14.....	4209
NESTOR—The Star Gazer, D.....	4212

Wednesday, November 4, 1914.

ANIMATED WEEKLY—No. 139, N.....	4217
ECLAIR—The Return, D., 2000.....	4214
JOKER—The Hoodoo, C.....	4213

Thursday, November 5, 1914.

IMP—The Universal Boy in "Mystery of N. Y. Docks".....	4218
REX—Let Us Have Peace, C., 2000.....	4219
STERLING—Dot's Chaperone, C.....	4221

Friday, November 6, 1914.

NESTOR—Those Were the Happy Days, C., 2000.....	4222
POWERS—Nan of the Hills, D.....	4224
VICTOR—Tale of a Lonesome Dog, C.....	4225

Saturday, November 7, 1914.

101 BISON—The Junglemaster, 2000.....	4229
FRONTIER—The Girl from Texas, D.....	
JOKER—Two Pals and a Gal, C.....	4227

Sunday, November 8, 1914.

ECLAIR—At the Crucial Moment, 1000.....	4233
L-KO—The Fatal Marriage, C.....	4234
REX—The Link That Binds, D., 2000.....	4231

RELEASES OF NEXT WEEK

Monday, November 9, 1914.

IMP—The Stronger Love, Mary Pickford Reissue, D..	4237
STERLING—An Ill Wind, C.....	4238
VICTOR—Terrance O'Rourke, Gentleman Adventurer.	4235
STRAND—War News, No. 9.....	4239

Tuesday, November 10, 1914.

CRYSTAL—The Life Saver, C.....	4243
GOLD SEAL—The Trey O' Hearts, Series No. 15, D.	4240
NESTOR—The Two Thieves, D.....	4244

Wednesday, November 11, 1914.

HEPWORTH—No Flies on Sis and A Friend in Need	4248
ECLAIR—The Yellow Streak, D., 2000.....	4246
JOKER—The Frankfurter Salesman's Dream and A Day With the French Army (Split Reel).....	4245

Thursday, November 12, 1914.

IMP—Peg of the Wilds, D., 2000.....	4250
REX—The Shoemaker's Eleventh, C.....	4252
STERLING—The Dog Raffles, C.....	4253
ANIMATED WEEKLY—No. 140.....	4249

Friday, November 13, 1914.

NESTOR—When the Girls Were Shanghaied, C.....	4254
HEPWORTH—Aboard the Lugger and Poor Luck....	4257
VICTOR—Mary Fuller in "Girl of the People," D., 2000	4255

Saturday, November 14, 1914.

101 BISON—The Silent Peril, D., 2000.....	4260
FRONTIER—The School Teacher at Angel Camp, D..	4259
JOKER—Defeat of Father and Fireproofing Children..	4258

Sunday, November 15, 1914.

ECLAIR—Her Own House, D.....	4265
L-KO—Lizzy's Escape, C.....	4264
REX—The Chorus Girls, D., 2000.....	4262

MUTUAL PROGRAM

RELEASES OF THE WEEK

Monday, November 2, 1914.

AMERICAN—The Ruin of Manley, D., 2000.....	02548
KEYSTONE—Lovers' Post Office, C., 1000.....	02551
RELIANCE—Our Mutual Girl, No. 42, D.....	02550

Tuesday, November 3, 1914.

BEAUTY—The Tightwad, C.....	02555
MAJESTIC—False Pride, D.....	02554
THANHOUSER—The Turning of the Road, D., 2000..	02552

Wednesday, November 4, 1914.

AMERICAN—When the Road Parts, D.....	02558
BRONCHO—The Desperado, D.....	02556
RELIANCE—The Miner's Peril, D.....	02559

Thursday, November 5, 1914.

DOMINO—In Old Italy, D., 2000.....	02560
KEYSTONE—Curses, They Remark'd, C., 1000.....	02562
MUTUAL WEEKLY—No. 97.....	02563

Friday, November 6, 1914.

KAY BEE—In the Clutches of the Gangsters, D., 2000.	02564
PRINCESS—When Vice Shatters, C.....	02566
THANHOUSER—The Chasm, D.....	02567

Saturday, November 7, 1914.

KEYSTONE—His Musical Career, C., 1000.....	02570
RELIANCE—A Woman Scorned, D., 2000.....	02568
ROYAL—Max's Money, C., 1000.....	02571

Sunday, November 8, 1914.

KOMIC—Ethel's Roof Party (Bill No. 10), C.....	02574
MAJESTIC—The Tear That Burned, D., 2000.....	02572
THANHOUSER—Keeping a Husband, C.....	02575

RELEASES OF NEXT WEEK

Monday, November 9, 1914.

AMERICAN—A Slice of Life, D., 2000.....	02576
KEYSTONE—His Trusting Places, C., 2000.....	Special
KEYSTONE—His Talented Wife, C., 1000.....	02579
RELIANCE—Our Mutual Girl, No. 43, 1000.....	02578

Tuesday, November 10, 1914.

BEAUTY—Motherhood, D., 1000.....	02583
MAJESTIC—The Niggard, D., 1000.....	02582
THANHOUSER—The Terror of Anger, D., 2000.....	02580

Wednesday, November 11, 1914.

AMERICAN—The Stolen Masterpiece, D., 1000.....	02586
BRONCHO—Destiny's Night, D., 2000.....	02584
RELIANCE—The Widow's Children, D., 1000.....	02587

Thursday, November 12, 1914.

DOMINO—The Friend, D., 2000.....	02588
KEYSTONE—An Incompetent Hero, C., 1000.....	02590
MUTUAL WEEKLY—No. 98.....	02591

Friday, November 13, 1914.

KAY BEE—The Hateful God, D., 2000.....	02592
MAJESTIC—The Folly of Anne, C., 1000.....	02595
PRINCESS—Seeds of Jealousy, D., 1000.....	02594

Saturday, November 14, 1914.

KEYSTONE—Not yet announced.....	02598
RELIANCE—The Floating Call, D., 2000.....	02596
ROYAL—A Fortune in Pants, C., 1000.....	02599

Sunday, November 15, 1914.

KOMIC—Out Again, In Again, C., 1000.....	02602
MAJESTIC—The Odalisque, D., 2000.....	02600
THANHOUSER—The Man With the Hoe, D., 1000...	02603

Cosmofotofilm Co



London Film Co.
(Trade Mark)

"Where the Real Features Come From"

"THE THIRD STRING"

Released through the PARAMOUNT PICTURES CORPORATION
An Excruciatingly Funny 2-Reel Comedy by W. W. JACOBS

World's Tower Bldg., 110 W. 40th St., New York

KRITERION

Kriterion Program

Will Be All American Made

**Consisting of Comedies, Dramas, Travels
and Educational Specials**

Mr. Exhibitor

You have been wondering where the old line Stars and Producers have gone.

There are no less than twenty of the leading Directors and Stars who have joined the Kriterion Banners. They have made you pleasing and successful moving pictures for past five years.

SUCCEEDING this issue you will jump with joy when we will announce our Brands, Stars and Names of Cooperative Management.

WHOM our all-star picture play program has been made by and is regularly being made to supply you.

ENQUIRE in cities that surround this space, or better yet, communicate with company below. All enquiries answered, giving full information.

"Note"—This space continues to "grow."

Mica Film Corporation

Temporary Headquarters

222 West 42nd Street

New York City

St. Louis

Minneapolis

Montreal

New York

Winnipeg

Boston

Los Angeles

Philadelphia

San Francisco

Baltimore

Seattle

Pittsburgh

Denver

Cleveland

Dallas

Cincinnati

Atlanta

Indianapolis

Kansas City

Chicago

RELEASE DATES FOR READY REFERENCE

GENERAL FILM PROGRAM

BIOGRAPH

10-29.	The Wife's Stratagem, D.	999
10-30.	The Tides of Sorrow, D.	997
10-31.	Hearts of Gold, D.	999
11- 2.	All for Business, D.	997
11- 3.	Masks and Faces, D.	2073
11- 5.	Butterflies and Orange Blossoms, C.	998
11- 6.	A Regular Rip, C.	476
	Getting the Sack, C.	523
11- 7.	The Dole of Destiny, D.	996
11- 9.	A Better Understanding, D.	1000
11-10.	The New Magdalen, D.	2073
11-12.	The Fleur-de-lis Ring, D.	998
11-13.	Life's Stream, D.	1000
11-14.	His Wife's Pet, C.	477
	The Deadly Despatch, C.	521

COLUMBUS

10-27.	Mulligan's Ghost, C.	1000
11- 3.	A Twisted Affair, C.	1000
11-10.	A Family Intermingle, C.	500
	Oh! What a Dream, C.	500

EDISON

10-27.	The Mystery of the Sealed Art Gallery, D.	1000
10-28.	The Lost Melody, D.	1000
10-30.	The Midnight Ride of Paul Revere, D.	2000
10-31.	The Hand of Iron, D.	1000
11- 3.	Shorty, D.	1000
11- 4.	Jenks and the Janitor, C.	500
	Buster Brown, C.	500
11- 7.	Getting to the Ball Game, C.	1000
11- 9.	With Slight Variations, C.	1000
11-10.	The Heritage of Hamilton Cleek, D.	1000
11-13.	A Question of Identity, D.	2000
11-14.	The Everlasting Triangle, D.	1000
11-16.	The Adventures of the Lost Wife, C.	1000
11-17.	A Moment of Madness, D.	1000
11-18.	Buster Brown and the German Band, Cart.	400
	A Millinery Mix-up, C.	600
11-20.	What Could She Do? D.	3000
11-21.	Dickson's Diamonds, D.	1000
11-23.	His Chorus Girl Wife, D.	1000
11-24.	A Gypsy Madcap, D.	1000
11-25.	The Temple of Moloch, D.	1000
11-27.	The King's Move in the City, D.	2000
11-28.	The Last of the Hargroves, D.	1000
11-30.	Wood B. Wedd Goes Snipe, C.	1000

ESSANAY

10-31.	Broncho Billy's Mother, D.	1000
11- 2.	The Laundry, C.	1000
11- 3.	Fires of Fate, D.	1000
11- 4.	The Fable of "How Uncle Brewster Was Too Shifty for the Tempter," C.	1000
11- 5.	Slippery Slim and the Impersonator, C.	1000
11- 6.	His Dearest Foes, D.	2000
11- 7.	Broncho Billy's Mission, D.	1000
11- 9.	Sweedie, the Trouble Maker, C.	1000
11-10.	Within Three Hundred Pages, D.	1000
11-11.	Three Boiled Down Fables, C.	1000
11-12.	Sophie and the Man of Her Choice, C.	1000
11-14.	Broncho Billy's Decision, D.	1000

KALEM

10-31.	The Vengeance of Winona, D.	1000
11- 2.	His Inspiration, D.	1000
11- 3.	Lizzie, the Life Saver, C.	1000
11- 4.	The Prison Stain, D.	2000
11- 6.	The Indian Suffragettes, C.	1000
11- 7.	The Man in the Vault, D.	1000
11- 9.	The Riddle of the Green Umbrella, D.	1000
11-10.	The Widow's Might, C.	1000
11-11.	A Midnight Tragedy, D.	2000
11-13.	Ham, the Piano Mover, C.	1000
11-14.	Helen's Sacrifice, D.	1000
11-16.	The Man of Iron, D.	2000
11-17.	The Peach at the Beach, C.	1000
11-18.	His Nemesis, D.	1000
11-21.	The Plot at the R. R. Cut, D.	1000
11-23.	The Theft of the Crown Jewels, D.	1000
11-24.	Tough Luck Smith, C.	1000
11-25.	The Girl and the Explorer, C.	2000
11-27.	Ham the Iceman, C.	1000
11-28.	The Girl at the Throttle, D.	1000
11-30.	Her Bitter Lesson, D.	2000

KLEINE

9-29.	A Shot from Ambush, D.	2000
10- 6.	The Wrecked Special, D.	2000
10-13.	On the Battle Line, D.	2000

LUBIN

11- 3.	The Boomerang Swindle, C.	1000
11- 4.	The Sorceress, D.	2000
11- 5.	The Stolen Yacht, D.	2000
11- 6.	Love Triumphs, D.	1000
11- 7.	Kidnapping the Kid, C.	400
	The Honor of the Force, C.	600
11- 9.	The Beloved Adventurer, Series No. 9, D.	1000
11-10.	Butt-Ing In, C.	400
	A Bargain Table Cloth, C.	600
11-11.	The Quack, D.	2000
11-12.	In the Hill of Kentucky, D.	2000
11-13.	The Trap, D.	1000
11-14.	Beating the Burglar, C.	400
	Magazine Cooking, C.	600
11-16.	The Beloved Adventurer, No. 10, D.	1000
11-17.	She Was the Other, C.	400
	Cheap Transportation, C.	600
11-18.	The Marriage Wager, D.	2000
11-19.	On Suspicion, D.	2000
11-20.	The Unknown County, D.	1000
11-21.	The Tale of a Coat, C.	400
	The Daddy of Them All, C.	600
11-23.	The Beloved Adventurer, No. 11, D.	1000
11-24.	Mother's Baby Boy, C.	400
	He Wanted Chicken, C.	600

RELEASE DAYS

GENERAL FILM PROGRAM

Monday	—Biograph, Edison, Essanay, Hearst-Selig News Pictorial, Kalem, Selig, Vitagraph.
Tuesday	—Columbus, Edison, Essanay, Geo. Kleine, Lubin, Selig, Vitagraph.
Wednesday	—Edison, Essanay, Kalem, Lubin, Selig, Vitagraph.
Thursday	—Biograph, Essanay, Hearst-Selig News Pictorial, Lubin, Selig, Vitagraph.
Friday	—Edison, Essanay, Kalem, Selig, Lubin, Vitagraph.
Saturday	—Biograph, Edison, Essanay, Kalem, Lubin, Vitagraph, Selig.

UNIVERSAL PROGRAM

Monday	—Victor, Imp, Powers.
Tuesday	—Gold Seal, Crystal, Nestor.
Wednesday	—Nestor, Joker, Eclair, Animated Weekly.
Thursday	—Imp, Rex, Frontier, Sterling.
Friday	—Nestor, Powers, Victor.
Saturday	—Joker, Frontier, 101 Bison.
Sunday	—Rex, Crystal, Eclair, L-KO.

MUTUAL PROGRAM

Monday	—American, Keystone, Reliance.
Tuesday	—Beauty, Majestic, Thanouser.
Wednesday	—American, Broncho, Reliance.
Thursday	—Domino, Keystone, Mutual Weekly.
Friday	—Kay-Bee, Majestic, Princess.
Saturday	—Keystone, Reliance, Royal.
Sunday	—Majestic, Komic, Thanouser.

11-25.	The Making of Him, D.	2000
11-25.	Was His Decision Right? D.	2000
11-26.	He Waits Forever, D.	1000
11-27.	You Can't Beat Them, C.	400
	The Servant Girl's Legacy, C.	600

SELIG

10-24.	The Tragedy That Lived, D.	1000
10-26.	Playing with Fire, D.	2000
10-26.	Hearst-Selig News Pictorial No. 69, N.	1000
10-27.	Why the Sheriff Is a Bachelor, D.	1000
10-28.	The Wasp, D.	1000
10-29.	Hearst-Selig News Pictorial No. 70, N.	1000
10-30.	The Grate Impeeryul Sirkus, C.	1000
10-31.	At the Transfer Corner, C.	1000
11- 2.	Rosemary, That's for Remembrance, D.	1500
11- 3.	The Teltale Knife, D.	1000

11- 4.	"C. D." D.	1000
11- 5.	Hearst-Selig News Pictorial, No. 72, N.	1000
11- 6.	No Wedding Bells for Her, C.	1000
11- 7.	The Losing Fight, D.	1000
11- 9.	When His Ship Came In, D.	2000
11- 9.	Hearst-Selig News Pictorial No. 73, N.	1000
11-10.	The Ranger's Romance, D.	1000
11-11.	Peggy, of Primrose Lane, D.	1000
11-12.	Hearst-Selig News Pictorial No. 74, N.	1000
11-13.	Cupid Turns the Tables, C.	1000
11-14.	The Fatal Note, C.	1000

VITAGRAPH

11- 2.	The Mystery of Brayton Court, D.	1000
11- 3.	On the Stroke of Five, D.	2000
11- 4.	The Evolution of Percival, C.	1000
11- 5.	The Choice, D.	1000
11- 6.	Thanks for the Lobster, C.	1000
11- 7.	In the Land of Arcadia, D.	2000
11- 9.	Miss Tomboy and Freckles, C.	1000
11-10.	The Senator's Brother, D.	2000
11-11.	In Bridal Attire, C.	1000
11-12.	Lola, the Rat, D.	1000
11-13.	The Rocky Road of Love, C.	1000
11-14.	Ann, the Blacksmith, D.	1362
	Making of a Newspaper, E.	638
11-16.	Sisters, D.	1000
11-17.	Hope Foster's Mother, D.	2000
11-18.	Fixing Their Dads, C.	1000
11-19.	Too Much Burglar, C.	1000
11-20.	The Professional Scapegoat, C.	1000
11-21.	Mary Jane Entertains, C.	2000
11-23.	The Level, D.	1000
11-24.	The Old Flute Player, D.	2000
11-25.	Netty or Letty, C.	1000
11-26.	Cause for Thanksgiving, C.	1000
11-27.	The Curing of Myra May, C.	1000
11-28.	Convict, Costumes and Confusion, C.	2000
11-30.	Everything Against Him, D.	1000

UNIVERSAL PROGRAM

ANIMATED WEEKLY

11- 4.	Weekly No. 139, N.	1000
11-11.	Weekly No. 140, N.	1000
11-18.	Weekly No. 141, N.	1000

101 BISON

11- 7.	A Small Town Girl, D.	3000
11-14.	The Silent Peril, D.	2000
11-21.	The Ninety Black Boxes, D.	2000

CRYSTAL

10-27.	Persistent Lovers, C.	1000
11- 2.	They Didn't Know, C.	1000
11-10.	The Life Saver, C.	1000
11-17.	Oh! You Mummy, and Naughty Nellie, split reel.	1000

ECLAIR

10-28.	The Mystery of Graysom Hall, D.	2000
11- 1.	At the Crucial Moment, D.	1000
11- 4.	The Return, D.	2000
11- 8.	At the Crucial Moment, D.	1000
11-11.	The Yellow Streak, D.	2000
11-15.	Her Own House, D.	1000
11-18.	The Wondrous Melody, D.	2000
11-22.	A Friend in Need, and Our Beloved Country; split reel.	1000

FRONTIER

10-24.	The Scarecrow's Secret, D.	1000
10-31.	The Blacksmith's Daughter, D.	1000
11- 7.	The Girl from Texas, D.	1000
11-14.	The School Teacher at Angel Camp, D.	1000
11-21.	Man to Man, D.	1000

GOLD SEAL

10-27.	The Trey o' Hearts, Episode No. 13, D.	2000
11- 3.	The Trey o' Hearts, No. 14, D.	2000
11-10.	The Trey o' Hearts, No. 15, D.	3000
11-17.	The Opened Shutters.	4000

Cosmofotofilm Co



London Film Co.
(Trade Mark)

"Where the Real Features Come From"

"CALLED BACK"

HUGH CONWAY'S GREAT MELODRAMA In Four Parts Produced by the LONDON FILM CO.
For Exclusive Rights, Address us at

World's Tower Bldg., 110 W. 40th St., New York



"SEE AMERICANS FIRST"
FLYING A' AND AMERICAN "BEAUTY" FILMS

"REDBIRD WINS"

In Two Parts. A Romance of the Paddock
Featuring VIVIAN RICH and WM. GARWOOD. Release Monday, November 16th, 1914

AMERICAN "BEAUTY" FILMS
Featuring MARGARITA FISCHER and HARRY POLLARD

"WHEN QUEENIE CAME BACK"

It's a Scream. You Cannot Afford to Miss It
Release Tuesday, November 17th, 1914

"FLYING A" FEATURES

"BEPPO"

A Human Interest Drama
Direction of Henry Otto
Release Wednesday, November 18th, 1914

"Old Enough To Be Her Grandpa"

A Light Comedy Sure To Please
Direction of Thos. Ricketts
Release Friday, November 20th, 1914

AMERICAN FILM MANUFACTURING CO.

CHICAGO

WHY DID
JUNE
RUN AWAY

WHO IS JUNE?
WHERE DID SHE RUN?

? ? ? ? ? ? ? ? ? ? ? ?

WHY DID
JUNE
RUN AWAY

WHO IS JUNE?
WHERE DID SHE RUN?

RELEASE DATES FOR READY REFERENCE — Continued

IMP

- 10—22. Universal Boy in "The Gates of Liberty".....
 10—26. Marie's Patients, and Educational; split reel.....
 10—29. In Self-Defense, D.....2000
 11— 2. The Turn of the Tide.....2000
 11— 5. The Universal Boy in "The Mystery of the New York Docks".....
 11— 9. The Stronger Love, Mary Pickford Reissue, D.....
 11—12. Peg of the Wilds, D.....2000
 11—16. The Treasure Train, D.....2000
 11—19. The Universal Boy in "A Marine Adventure".....

JOKER

- 10—14. On Again, Off Again, Finnigan, C..
 10—17. Across the Court, C.....
 10—21. The Countess Count, C.....
 10—28. Noads' Adless Day, C.....
 10—31. When Their Wives Joined the Force, C.....
 11— 4. The Hoodoo, and Educational.....
 11—11. The Frankfurter Salesman's Dream, C..
 11—14. Defeat of Father, and Educational, C..
 11—18. His Night Out, C.....
 11—21. The Battle of the Nations, C.....

L-KO

- 11—15. Lizzy's Escape, C.....
 11—22. The Groom's Doom, C.....

NESTOR

- 10— 7. The Old Bell Ringer, D.....
 10— 9. He Never Said a Word, C.....
 10—16. The Way of Life, D.....
 10—23. Cupid Pulls a Tooth, and Mt. St. Bernard, Switzerland; split reel.....
 10—27. The Wall of Flame, D.....
 11— 3. The Boy Major, D.....
 11— 6. Those Were the Happy Days, C.....2000
 11—10. The Two Thieves, D.....
 11—13. When the Girls Were Shanghaied, C..
 11—20. When Their Brides Got Mixed, C.....
 India's Defender of the British Empire, E.....

POWERS

- 10—16. The Padrone's Ward, D.....2000
 10—23. Suspended Sentence, C.....
 10—30. The Senator's Lady, D.....
 11— 6. Nan of the Hills, D.....
 11—13. Sissy Dobins' Oil Magnet, C.....
 11—20. A Scenario Editor's Dream, C.....

REX

- 10—18. Kid Regan's Hands, D.....2000
 10—22. Olaf Erickson—Boss, D.....2000
 10—25. The Little Blond Lady, D.....
 10—29. White Roses, D.....
 11— 1. The Vagabond, D.....2000
 11— 5. Let Us Have Peace, C.....2000
 11— 8. The Link That Binds, D.....2000
 11—12. The Shoemaker's Eleventh, C.....
 11—15. The Chorus Girl's Thanksgiving, D.....2000
 11—19. His Uncle's Will, D.....2000
 11—22. Traffic in Babies, C.....

STERLING

- 11— 5. Dot's Chaperon, C.....
 11— 9. An Ill Wind, C.....
 11—12. The Dog Rafines, C.....
 11—16. A Bear Escape, C.....
 11—19. Noodles' Return, C.....

UNIVERSAL IKE

- 10— 6. The Neglected Wife.....
 10—13. Mary Green's Husband, and Educational, C.....
 10—13. Mary Green's Husband, and The Monkey Cabaret, C., split reel.....

VICTOR

- 10—26. Terrence O'Rourke No. 1, D.....2000
 10—30. The Witch Girl, Mary Fuller, D.....2000
 11— 2. Mary Fuller in "His Big Chance," D..
 11— 6. Tale of a Lonesome Dog, C.....
 11— 9. Terrence O'Rourke, Gentleman Adventurer, D.....2000
 11—13. Mary Fuller in "Girl of the People," D.....2000
 11—16. Mary Fuller in "The Phantom Cracksmen," D.....
 11—20. For the People, D.....2000

MUTUAL FILM PROGRAM

AMERICAN

- 10—28. Sweet and Low, D.....1000
 11— 2. The Ruin of Manley, D.....2000
 11— 4. When the Road Parts, D.....1000
 11— 9. Red Bird Wins, D.....2000
 11—11. The Stolen Masterpiece, D.....1000
 11—16. Red Bird Wins, D.....2000
 11—18. Beppo, D.....1000
 11—20. Old Enough to Be Her Grandpa, C.....1000

BEAUTY

- 10—13. Winsome Winnie, C.....1000
 10—20. Dad and the Girls, C.....1000
 10—27. A Rude Awakening, C.....1000
 11— 3. The Tightwad, D.....1000
 11—10. Motherhood, D.....1000

BRONCHO

- 11—11. Destin's Night.....
 11—18. Shorty Falls Into a Tide, C.....2000
 11—25. The Cross in the Desert.....2000
 12— 2. A Romance of Old Holland.....2000

DOMINO

- 10—29. Eric the Red's Wooing.....
 11— 5. In Old Italy.....
 11—12. The Friend.....2000
 11—19. Nipped.....2000
 11—26. The Mills of the Gods.....2000
 12— 3. The Vigil.....2000
 12—10. Not of the Flock.....2000

KAY-BEE

- 10—23. The Spark Eternal.....2000
 10—30. The Worth of a Life.....
 11— 6. In the Clutches of the Gangster.....2000
 11—13. The Hateful God.....2000
 11—20. The Master of the House.....2000
 11—27. A Crook's Sweetheart.....2000

KEYSTONE

- 9—17. Bombs and Bangs, C.....
 9—19. Lover's Luck, C.....
 9—21. He Loved the Ladies, C.....1000
 9—24. The New Janitor, C.....1000
 9—28. Hard Cider, C.....1000
 10— 1. Killing Horace, C.....1000
 10— 3. Fatty Again, C.....1000
 10— 5. Their Ups and Downs, C.....1000
 10— 8. Hello Mabel, C.....1000
 10—10. Those Love Pangs, C.....1000
 10—12. Anglers, C.....1000
 10—15. High Spots on Broadway, C.....1000
 10—19. Dash, Love and Splash, and Santa Catalina Islands, split reel.....
 10—22. Love Siege, C.....1000
 10—24. Stout Heart but Weak Knees, C.....1000
 10—26. Shot in the Excitement, C.....1000
 10—26. Dough and Dynamite, C.....2000
 10—29. Gentlemen of Nerve, C.....1000
 10—31. Cursed by His Beauty, C.....1000
 11— 2. Lovers' Post Office, C.....1000
 11— 5. Curses They Remark'd, C.....1000
 11— 7. His Musical Career, C.....1000
 11— 9. His Trysting Places, C.....2000

KOMIC

- 11— 1. Casey's Vendetta.....
 11— 8. Ethel's Roof Party (No. 10).....
 11—15. Out Again, In Again.....
 11—22. Ethel Has a Steady (No. 11).....
 11—29. A Corner in Hats.....
 12— 6. Bill No. 12.....

MAJESTIC

- 10—20. Environment.....
 10—25. Paid with Interest.....2000
 10—27. A Mother's Influence.....
 11— 1. Paid with Interest.....
 11— 3. False Pride.....
 11— 8. The Tear That Burned.....2000
 11—10. The Niggard.....
 11—13. The Folly of Ann.....
 11—15. The Odalisque.....2000
 11—22. The Saving Grace.....2000
 11—24. Another Chance.....
 11—29. The Sisters.....2000
 12— 1. The Old Good for Nothing.....

MUTUAL WEEKLY

- 10—24. No. 91.....
 11— 1. No. 92.....
 11— 8. No. 93.....
 11—15. No. 94.....
 11—22. No. 95.....
 10—27. No. 96.....
 11— 3. No. 97.....
 11—10. No. 98.....

PRINCESS

- 10— 2. The Balance of Power.....
 10— 9. The One Who Cared, D.....
 10—16. The Touch of a Little Hand.....
 10—23. The Face at the Window.....
 10—30. The Dead Line.....
 11— 6. When Vice Shuddered.....
 11—13. Seeds of Jealousy.....

RELIANCE

- 10—24. A Blotted Page.....2000
 10—26. Our Mutual Girl No. 41.....
 10—30. The Availing Prayer.....
 10—31. The Wrong Prescription.....
 11— 2. Our Mutual Girl No. 42.....
 11— 4. The Miner's Peril.....
 11— 7. A Woman Scorned.....
 11— 9. Our Mutual Girl No. 43.....
 11—14. The Floating Call.....
 11—16. Our Mutual Girl No. 44.....
 11—18. The Hidden Message.....
 11—21. His Responsibility.....2000
 11—23. Our Mutual Girl No. 45.....
 11—25. They Never Knew.....
 11—27. The Hop Smugglers.....
 11—28. The Kaffir's Skull.....2000
 11—30. Our Mutual Girl No. 46.....

ROYAL

- 10—17. The Black Hand.....
 10—24. Harold's Toupee.....
 10—31. Phil's Vacation.....
 11— 7. Max's Money.....
 11—14. A Fortune in Pants.....
 11—21. Love Finds a Way.....

THANHOUSER

- 10— 4. A Dog's Love.....
 10— 6. The Cripple.....
 10— 9. The Benevolence of Conductor 786..
 10—11. The Rescue.....
 10—13. The Diamond of Disaster.....2000
 10—18. Left in the Train.....
 10—20. Old Jackson's Girl.....2000
 10—25. Mr. Cinderella.....
 10—27. A Madonna of the Poor.....2000
 11— 1. Shep's Race with Death.....
 11— 3. The Turning of the Road.....
 11— 8. Keeping a Husband.....
 11—10. The Terror of Anger.....
 11—13. The Chasm.....
 11—15. The Man with the Hoe.....
 11—17. Pawns of Fate.....2000
 11—22. A Messenger of Gladness.....
 11—24. Mrs. Van Ruyter's Stratagem.....2000
 11—29. A Denver Romance.....

RELEASE DATES FOR READY REFERENCE — Continued

FEATURE RELEASES

ALCO FILM CORPORATION

ALL STAR

- 10— 5. The Nightingale, D.....5 parts
- 10—19. Shore Acres.....5 parts
- The Easiest Way.....

CALIFORNIA MOTION PICTURE CORP.

- 11— 2. Salomy Jane.....5 parts
- Mrs. Wiggs of the Cabbage Patch..

LIFE PHOTO FILM CORPORATION

- Sept. Captain Swift, D.....5 parts
- Oct. The Ordeal, D.....5 parts
- Dec. Springtime.....

POPULAR PLAYS AND PLAYERS

- 10—12. The Ragged Earl, D.....
- 10—26. Michael Strogoff, D.....5 parts
- 11— 9. The Tigress.....

B. A. ROLFE PHOTO PRODUCTIONS

- Nov. Rip Van Winkle.....5 parts
- The Three of Us.....

TIFFANY MOTION PICTURE CORP.

- Heart of Maryland.....

ALLIANCE FILMS CORPORATION

EXCELSIOR FEATURE FILM CO.

- 11—23. When Fate Leads Trump.....

FAVORITE PLAYERS

- 11—16. The Man Who Couldn't Lose.....

PROGRESSIVE MOTION PICTURE CO.

- 11— 2. McVeagh of the South Seas, D.....5 parts

SELECT PHOTO-PLAY PRODUCING CO.

- 10—26. At the Old Cross Roads, D.....5 parts

MASTERPIECE FILM COMPANY

- 11— 9. The Hoosier Schoolmaster.....5 parts

APEX

- Sept. Queen of the Counterfeiters, D.....4 parts
- Oct. Called to the Front; or Europe at War, D.....3 parts

COSMOS FEATURE FILM CORPORATION

- Lena Rivers, D.....5 parts
- Hearts and Flowers, D.....5 parts

COSMOFOTOFILM CORPORATION

- Aug. What a Woman Will Do, D.....4 parts
- Sept. England's Menace, D.....3 parts
- Oct. England Expects—, D.....

ECLECTIC FILM COMPANY

- Perils of Pauline, No. 14, D.....
- Colonel Heeza Liar in the Wilderness, C..... 700
- Strange Animals, E..... 300
- Pathé Daily News No. 62-1914, Top..
- The Colonel's Wife, D.....
- Pathé Daily News No. 63-1914, Top..
- Pathé Daily News No. 64, Top.....
- Second Door Left, C.....
- War Stricken Louvain, Topical.....
- Pathé Daily News No. 65, Top.....
- Oct. The Ticket of Leave Man, D.....3 parts
- Oct. The King of the Air, D.....3 parts
- Oct. The Count That Took the Count, C..
- Oct. The Warning, D.....3 parts
- Oct. The Broken Promise, D.....4 parts
- Oct. Miss Cinderella, C.....
- The Poor Little Rich Boy.....
- Whiffles Has a Toothache.....
- A Change of Heart.....
- A World Without Men.....
- The Perils of Pauline, 16th Episode.
- A Soldier's Duty.....
- The Old Fogey.....

E. & W. TRANSFILM BUREAU

- Oct. Modern Warfare, D.....6 parts

HEPWORTH-AMERICAN

- Aug. The Girl from the Sky, C.....
- 8—29. The Chimes, D.....3 parts
- The Terror of the Air, D.....2 parts
- Sept. Creatures of Clay, D.....3 parts

HECTOR FILM CORPORATION

- Sept. Born Again, D.....5 parts

KINETOPHOTO CORPORATION

- Oct. Markia.....5 parts
- Oct. Spirit of the Poppy.....6 parts
- Nov. Span of Life.....

OZ FILM COMPANY

- Oct. Patchwork Girl of Oz.....5 parts
- Oct. His Majesty, The Scarecrow of Oz..5 parts
- Nov. The Last Egyptian.....

PARAMOUNT PICTURES

BOSWORTH

- 10— 1. Pursuit of the Phantom.....5 parts
- 10—19. Hypocrites!.....4 parts
- 11—23. The Country Mouse.....4 parts

FAMOUS PLAYERS

- 10—26. Behind the Scenes.....5 parts
- 11— 9. Man from Mexico.....5 parts
- 11—30. Mrs. Black Is Back.....
- 12—21. Step Sisters, D.....5 parts
- 12—28. The Crucible, D.....5 parts
- 12—31. The Million, D.....4 parts

JESSE LASKY COMPANY

- 10—22. What's His Name?.....5 parts
- 11—16. The Rose of the Rancho.....5 parts
- 11—26. The Man from Home.....5 parts
- 12— 7. Ghostbreakers, D.....5 parts

LASKY-LIEBLER

- 12—24. Cameo Kirby, D.....5 parts

SMALLEYS

- 12—17. False Colors, D.....5 parts

PLAYGOERS FILM COMPANY

- Oct. The Great Diamond Robbery, D.....6 parts

PICTURE PLAYHOUSE FILM COMPANY, INC.

- 11— 2. For King and Country.....
- 11—10. The Last Dance.....
- 11—18. The Wild Flower.....
- 11—26. The Black Envelope.....
- 12— 2. Convict 555.....
- 12—10. Partners.....

RENOWNED PLAYERS

- Sept. A Great Mistake, D.....5 parts

SAWYER, INCORPORATED

- Sept. Tyranny of the Mad Czar, D.....4 parts
- Sept. Doc, D.....4 parts
- Oct. Thirty Minutes in Melodrama, C.....2 parts
- Oct. The Factory Magdalen, D.....4 parts
- Oct. The Volunteer Parson, D.....4 parts
- Oct. The Detective Queen, D.....4 parts

WARNER'S FEATURES

- Sept. The Price of Crime, D.....3 parts
- Oct. Hunted Down, D.....
- Oct. In the Duke's Power, D.....
- Oct. Bess of the Blazing Sea, D.....
- Oct. The Adventures of Kitty Cobb, D..
- Oct. False Pride Has a Fall, C.....3 parts
- Oct. The Hypnotic Violinist, D.....3 parts
- Even Unto Death, D.....

WORLD FILM CORPORATION

- 9—14. Protea II, D.....5 parts
- 9—21. The Dollar Mark, D.....5 parts
- 9—28. Mother, D.....4 parts
- The Man in the Cellar, D.....

BOX OFFICE ATTRACTION CO.

BALBOA

- Sept. Criminal Code.....4 reels
- Oct. Rose of the Valley.....2 reels
- Oct. Test of Manhood.....3 reels
- Oct. Little Sunbeam.....3 reels
- Oct. The End of the Bridge.....3 reels
- Nov. Little Jack.....3 reels
- Nov. Message of the Mind.....3 reels
- Nov. The Call of the Heart.....2 reels

NEMO

- Sept. The Winner.....3 reels
- Oct. Through the Night to Light.....3 reels
- Oct. The Vow.....3 reels
- Oct. Through Fire and Water.....2 reels
- Oct. Seeds of Jealousy.....3 reels
- Nov. Bitter Sweets.....3 reels

WHITE STAR

- Sept. Storms of Life.....2 reels
- Oct. The Awakening.....3 reels
- Oct. The Judge's Wife.....3 reels
- Oct. A Great Secret.....3 reels
- Oct. The Bracelet.....3 reels
- Nov. The Mask.....2 reels
- Nov. To Love and to Hold.....2 reels
- Nov. Vengeance of the Flames.....3 reels

BOX OFFICE ATTRACTION CO.

SPECIAL FEATURES

- 11— 9. Life's Shop Window.....
- 11—19. The Walls of Jericho.....
- 11—29. The Thief.....

UNITED FILM SERVICE

WARNER'S FEATURES, INC.

LUNA

- 11—12. Reuben's Busy Day, C.....1 reel
- 11—19. Sage Brush Leading Lady, C.....1 reel

MITTENTHAL

- 11— 8. The Tenor of a Great City.....3 reels

PREMIER

- 11—14. Gypsy's Warning, D.....1 reel
- 11—21. Bandit of Devil's Gap, D.....1 reel

SAVOIA

- 11— 8. The Lost Chord.....3 reels

STARLIGHT

- 11—10. The Villain Still Pursued Her, C..1 reel
- 11—17. Noisy Neighbors, C.....1 reel

ANIMATED SONGS

Imperial Motion Picture Co., New York
Latest Releases:

- There's a Lonesome Little Girl in a Lonesome Little Town.
- She Was My Dad's First Sweetheart.
- Down Where the Old Road Turns.
- Push It Along.
- She's Just a Bird in a Gilded Cage.

Famous Players Film Co.

Jesse L. Lasker

Paramount

distributed by a perfect system
at the corner of the
Paramount Distributors and

1 FAMOUS PLAYERS FILM CO. OF ENGLAND, 31 Beach St., Boston, Mass.—Maine, New Hampshire, Massachusetts, Rhode Island and Connecticut.

2 WILLIAM L. SHERRY FEATURE FILM CO., INC., 126 West 46th St., New York City—New York State.

3 FAMOUS PLAYERS EXCHANGE, 71 West 23rd St., New York City. 1321 Vine St., Philadelphia, Pa.—New Jersey and Eastern Pennsylvania.

4 FAMOUS PLAYERS EXCHANGE, Room 41, Second National Bank Bldg., Washington, D. C.—Delaware, Maryland, District of Columbia and Virginia.

5 FAMOUS PLAYERS FILM SERVICE 404 Ferry St., Pittsburgh, Pa.—Western Pennsylvania, West Virginia, Ohio and Kentucky. 37 South Wabash Ave., Chicago, Ill.—Illinois and Indiana.

6 CASINO FEATURE FILM CO., Dime Bank Bldg., Detroit, Mich.—Michigan.



Have you booked Paramount
nearest exchange for list of re



Paramount Pict

ONE HUNDRED and TEN WEST
NEW YORK,

Paramount Pictures

ky Feature Play Co.

Bosworth, Inc., *Producers of*

Pictures

tem that covers every nook and
United States
their respective territories are:

7 KANSAS CITY FEATURE FILM COMPANY, Gayety Theatre Bldg., Kansas City, Mo.—Missouri, Kansas, Nebraska, Iowa.

8 FAMOUS PLAYERS STAR FEATURE FILM SERVICE, Temple Court Bldg., Minneapolis, Minn.—Minnesota, Wisconsin, North and South Dakota.

9 NOTABLE FEATURE FILM CO., Boston Bldg., Salt Lake City, Utah—Utah, Montana and Idaho. 1641 Stout St., Denver, Col.—Colorado, Wyoming.

10 PROGRESSIVE MOTION PICTURE CO., 642 Pacific Bldg., San Francisco, Cal.—California, Nevada. Central Bldg., Seattle, Wash.—Washington and Oregon. Los Angeles, Cal.—Lower California, Arizona, New Mexico.

11 SOUTHERN PARAMOUNT PICTURES CO., 65 Walton St., Atlanta, Ga.—North and South Carolina, Tennessee, Georgia, Alabama, Florida. 109 University Pl., New Orleans, La.—Mississippi and Louisiana.

12 TEXAS PARAMOUNT PICTURES CO., 1902 Commerce St., Dallas, Tex.—Arkansas, Texas and Oklahoma.

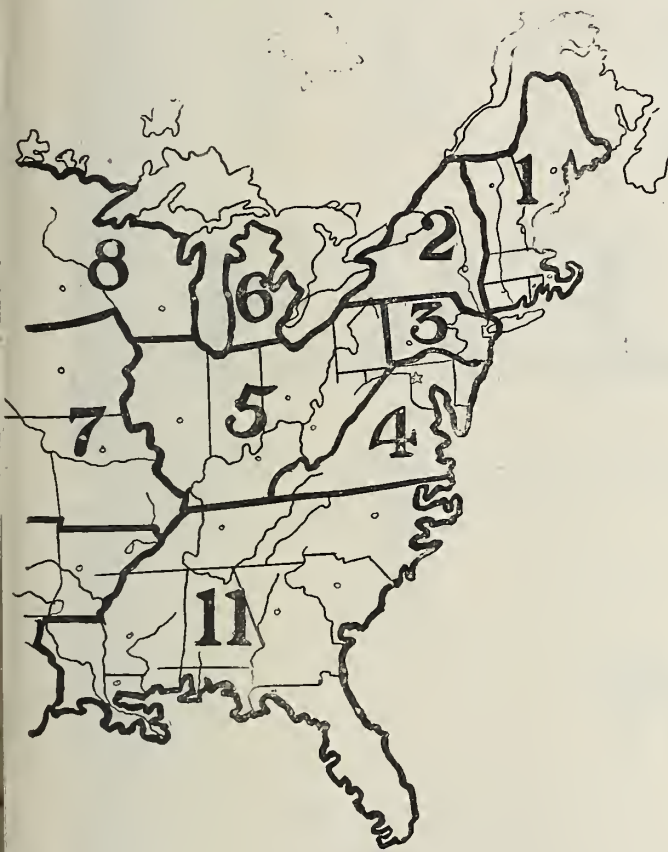

Pictures? If not, write our
leases and other information.

Paramount Pictures Corporation
FORTIETH STREET
CITY, N.Y.



Paramount Pictures

LANDED!!!

A WHALE

We have just concluded negotiations with the Selig Polyscope Co., whereby we have secured the New York State rights to Rex Beach's masterpiece,

THE SPOILERS

Probably the most talked of and Popular Feature that has been made in recent years. Our rights include Greater New York and the film is ready

NOW

Exhibitors desiring to book this big money-getter may drop in and look it over at the Broadway Rose Gardens, New York City, where it is on for an Indefinite Run.

**NEW YORK ALCO
FILM SERVICE Inc.**

Alco Bldg., 218 West 42nd Street, New York

***EXHIBITORS: Give them Away
And Pack Your House***

**\$1⁰⁰ COLORED
PHOTOGRAPHS**

OF FAMOUS

Lillian Walker

FREE

TO YOUR PATRONS

These richly colored portraits on heavy Art photo-board, to stand on a bureau or mantelpiece will not require framing as embossed design frames them.

A new pose—rich in color. The most beautiful and artistic colored photograph ever made of this popular star with the famous dimple.

Mr. Exhibitor: This offer is made for one purpose only. To place at our expense in the home of every one of her admirers a portrait of Miss Lillian Walker, who ranks with Mary Pickford and Alice Joyce in beauty and popularity.

Through you alone can we accomplish this purpose. Hence our liberal offer. These portraits are the equal of those sold in art stores at one dollar. Nothing but her name appears on the portrait. There are no strings or conditions beyond those stated in the coupon. We hereby guarantee to immediately return without question the small sum asked for packing and express charges, if the colored photographs are not found to be as represented in every particular.

Show one in your lobby, or run a slide reading: "A \$1.00 Photograph of Lillian Walker with every Ten Admissions", or distribute according to whatever plan may seem to you best to increase your box office receipts.

Your patrons will be eager to secure so valuable a portrait of such a favorite player. You can reorder on the same terms.

Photoplayers Own Company

1505 BROADWAY NEW YORK

REFERENCES

Any trade paper or your bank.



Copyrighted 1914

The Art Color Portrait is about twenty times as large as above picture. It is NOT a lithograph. It is impossible to give in the above crude cut an idea of the large colored photograph as it appears on heavy art photo-board.

Tear out and mail NOW



VALUABLE COUPON

Send me free 200 large colored photographs on heavy art photo-board of Lillian Walker, worth one dollar each, which I agree to distribute to her admirers.

Enclosed find my check for \$8.75 to cover cost of handling and prepayment of all express charges.

.....
Name

.....
Street address

.....
City and State

Fill In and MAIL THIS MINUTE



A vivid picturization of the present terrible war in 4 reels of TRUTHS and THRILLS. Every important incident from the assassination of the Austrian Crown Prince in Bosnia to the very recent battles along the Aisne.

PUBLICITY—Better than can be imagined—Took Broadway by storm—One sheets, three sheets, six sheets, heralds, photos, large, medium and postal size, cuts and free newspaper material.

Passed by the National Board of Censors and by them declared to be (we quote verbatim), "A picture that will be of interest to ALL who are READING of the WAR IN EUROPE."

Be first in your territory. Wire now for your proposition. Orders filled only in rotation, as received.

Further series will follow.



"FOR KING AND COUNTRY"

(Picture Playhouse—Six Reels)

REVIEWED BY PETER MILNE

ALTHOUGH the plot of this offering was once worked to death it has been absent from the screen for some time. Its revival will be welcome. It is a story of the heir to the throne being kidnapped by jealous parties in the state, so that one of their number might be made the ruler of the land. Just as the well laid plans of the conspirators seem to be taking effect they are dashed to the ground by the reappearance of the heir and his father, who was also made captive.

In all the six reels of the picture hardly a fault can be found with the photographic work. Foreign pictures have always been noted for their superiority in this line of the producing, but here the photography seems even better than the best. Beautiful exteriors have also been caught, and the beauty of the entire picture is materially enhanced by excellent tinting of the film.

The acting of the cast is of the highest grade also. It is of the emotional variety, characteristic of all the Italian players, and what is more to the point, it is the best sample of its kind.

A. A. Capozzi plays the leading male part. He appears as Sergius, the Crown Prince of Servia, who, with his little son, is kidnapped by the party of the conspiring Regent. Princess Ruspoli appears in the opposite part as the wife of Sergius, and in a role that requires much dramatic ability. Luigi Mele is the heavy of the story. He has been in these films before, and plays a role here well suited him. Michele Ciusa furnishes what little comedy the picture boasts of. The rest of the cast act commendably.

The story with its many sub-plots is of an interesting nature. Nothing sensational appears, and the action is almost always slow. It could be condensed, and it will be to some extent. As it stands at present it is slightly too long.

30 POLICE DOGS WILL "ACT" IN THANHOUSER FILM

THIRTY German police dogs are being used in "The Center of the Web," a two reeler now in the making at the New Rochelle studio of the Thanhouser Film Corporation. These dogs only recently arrived in this country from Germany where they had been used successfully in the tracking and apprehension of criminals.

Closely resembling wolves the dogs made a queer looking pack as they awaited Director Harvey's bidding. Heavy collars with sharp nails are used to discipline them.

When a dog becomes unruly this collar is turned so that the nails quickly restore him to better temper and obedience. The man in charge of the dogs spoke to them in German as they are not trained to commands in English.

One of the dogs however, understands directions given him in French. This animal was sold for \$1,600, but represents such a splendid type of his breed that permission was given by the new owner, a wealthy Greenwich woman, to work him in the picture.

RIFKIN WILL HANDLE ALLIANCE PROGRAM

IT was announced by Andrew J. Cobe, General Manager of the Alliance Films Corporation, that arrangements have been completed whereby the Eastern Feature Film Company, Inc., will handle the Alliance Program in the New England territory.

Herman Rifkin, president and general manager of the Eastern Feature Film Co., Inc., with offices at 57-59 Church street, Boston, Mass., is well known to the exhibitors in New England and the news of his having secured the Alliance Program for that territory will be greatly welcomed by them.

They will have to start with, "The Hoosier Schoolmaster," featuring Max Figman, "The Key to Yesterday," "The Path Forbidden," "At the Old Cross Roads," and "McVeagh of the South Seas." One big production a week will be released by the Alliance Films Corporation.

Exhibitors of that territory should get in touch with Mr. Rifkin for the Alliance Program for their theatre.

VACATION FOR CLEO MADISON

NOW that she has passed without serious injury 32 reels of imminent death in the production of the "Trey o' Hearts" series, Cleo Madison the plucky little lead with the Luca Gold Seal Company, has decided to do what she has said she would never do. She is taking a week's vacation.

No Author Ever Lived

Who has been able to conceive, in fiction, one-tenth of the strange, weird and thrilling experiences for his characters that have actually been encountered by the two confidential aides of William J. Flynn, Chief of the United States Secret Service, and who will be the principal characters in

The Great Secret Service Serial

Every hazard and risk encountered by Secret Service Operatives, every form of crime and law-breaking which they fight, is included in the twenty episodes of this wonderful serial. Each episode will average three reels. Each release will tell a complete story, but the same principals—a man and a woman—have the stellar parts in all of the twenty episodes.

Chief Flynn is writing the narrative for each release. One newspaper in every city and town in the country will publish each of the twenty stories.

The shrewd exhibitor, linking this publicity close to the dates he shows the serial, utilizing Chief Flynn's name, the wonderful advantages it and the productions give, is going to make money.

The productions are being staged under the personal direction of C. V. Henkel. This serial is being marketed entirely to state rights buyers. It is the first legitimate, bona-fide thing they have had to compete with the highly successful program serials.

Certain territories are still available. Bookings already are being made.

If you are an exhibitor, write to the address below for your bookings. If you are a buyer who knows what to buy, wire

FILM ATTRACTIONS COMPANY, Inc.

1482 Broadway

New York City

C. V. Henkel

Pres. and Gen'l Mgr.

ALCO FILM CORPORATION

Of California

Announces to Motion Picture Exhibitors of
SOUTHERN CALIFORNIA AND ARIZONA

The Opening of a New Exchange
at 531 West Eighth St., Los Angeles

All Alco Releases, with their unexcelled Advertising, will be handled exclusively for this territory by this exchange.

Mr. E. H. Emmick, of Golden Gate Film Exchange, as manager, extends an invitation to all to call, get acquainted, and learn of the excellence of this new program.

Telephones: Sunset Main 1168, Home F 1108

LUBIN

A CONTINUATION OF "MASTERPIECE" SUCCESSES
EVERY EXHIBITOR SHOULD BOOK THESE EXCEPTIONAL PICTURES

(Through the General Film Special Service)

"MARAHA, THE PYTHONESS"

3 Reel Drama By Clay M. Greene Direction—Joseph W. Smiley

"THE WEIGHT OF A CROWN"

3 Reel Drama By M. B. Havey Direction—Harry C. Myers

By Arrangement with Fred Mace

EVELYN NESBIT THAW

and her son, RUSSELL WILLIAM THAW, in

"THREADS OF DESTINY"

5 Reel Drama By Wm. H. Clifford Direction—Joseph W. Smiley

"STONEWALL JACKSON'S WAY"

3 Reel Drama By Emmett Campbell Hall Direction—Edgar Jones

READY FOR EARLY RELEASE

EDWIN ARDEN

8 Reel—7000 feet IN "EAGLE'S NEST" Direction—
Drama by Edwin Arden Romaine Fielding

RAYMOND HITCHCOCK In a 5 Reel Comedy Drama
by Lawrence McCloskey
Direction—George W. Terwilliger

ROSE COGHLAN

And ETHEL CLAYTON in

"THE SPORTING DUCHESS"

7 Reel—6500 Ft. Comedy Drama by Cecil Raleigh Direc.—Barry O'Neil

3 Reel Drama "THE SPY'S FATE" Direction—
By W. H. Lippert Joseph W. Smiley

IN PREPARATION

"THE COLLEGE WIDOW"

Featuring ETHEL CLAYTON and GEORGE SOULE SPENCER
5 Reel Comedy By George Ade Direction—Barry O'Neil

SIX REGULAR RELEASES EACH WEEK

"THE BELOVED ADVENTURER"—Ninth of Series, Drama... Monday,	November 9th
"Lord Cecil Plays a Part"	
"BUTT-ING IN"	
"A BARGAIN TABLE CLOTH" } Split Reel Comedies..... Tuesday,	November 10th
"THE QUACK"—Drama, Two Reel Wednesday,	November 11th
"IN THE HILLS OF KENTUCKY"—Drama, Two Reel Thursday,	November 12th
"THE TRAP"—Drama Friday,	November 13th
"BEATING THE BURGLAR" } Split Reel Comedies..... Saturday,	November 14th
"MAGAZINE COOKING"	

SPECIAL ONE, THREE AND SIX SHEET POSTERS.

Lubin Manufacturing Company, Philadelphia, Pa.

Chicago Office:
154 West Lake Street



LUBIN

A SERIES OF BEAUTIFUL PHOTOPLAYS
THE TALK OF THE MOVIE FANS

“The Beloved Adventure”

By Emmett Campbell Hall

Featuring

Arthur Johnston *and* Lottie Briscoe

ALSO PUBLISHED IN BOOK FORM

First Edition of 50,000 Copies Sold. Second Edition Now Ready.

HERALDS

for
“The Beloved Adventurer”
from
Hennegan & Co.,
Cincinnati, Ohio.

POSTERS

from
the A. B. C. Co.,
Cleveland, Ohio.

Released on the regular programme every Monday through the General Film Co.

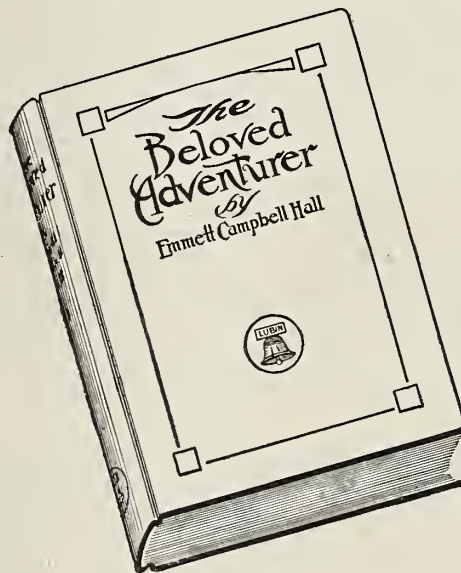

- 1st of Series—
“Lord Cecil Intervenes”
- 2nd of Series—
“An Untarnished Shield”
- 3rd of Series—
“An Affair of Honor”
- 4th of Series—
“An American Heiress”
- 5th of Series—
“The Girl from the West”
- 6th of Series—
“The Golden Hope”
- 7th of Series—
“The Holdup”
- 8th of Series—
“A Partner to Providence”
- 9th of Series—
“Lord Cecil Plays a Part”
- 10th of Series—
“Lord Cecil Keeps His Word”
- 11th of Series—
“The Serpent Comes to Eden”

A Series of 15 Single Reel Dramatic Photoplays— One Released Each Monday
The First Was Released September 14th

Fifteen chapters to the book, each chapter in its regular order, representing a release. FULL CLOTH BINDING, with fifteen full page half-tone illustrations, including an autographed frontispiece of Arthur Johnson

Single copies, 25 cents; in lots of 25 or more, 15 cents each

Secure these books from the General Film Co. Exchanges. Exhibitors are urged to place immediate orders as the edition is limited.



Lubin Manufacturing Company

Philadelphia, Pa.

Chicago Office, 154 West Lake Street



Cosmofotofilm Co



London Film Co.
(Trade Mark)

"Where the Real Features Come From"
TWO GREAT CHRISTMAS OFFERINGS!
"THE TWO COLUMBINES"
AND
'A CHRISTMAS CAROL'
World's Tower Bldg., 110 W. 40th St., New York

Moving Picture Scenarios

We are in the market for one and two reel comedies and comedy dramas.

Submit in typewritten form to

J. C. BROWNELL

105 Lawrence Avenue, Dept C,
Dorchester, Mass.

Holland Film Manufacturing Co.

RELIANCE COMPANY CHANGES FEATURE POLICY

A NEW policy was recently established by the Reliance Company relative to special features, when the announcement was made that in the future the special features that have been made will be sold on a states right proposition instead of being released through their affiliated organizations.

"The Avenging Conscience" or "Thou Shalt Not Kill," a six reel D. W. Griffith special feature, and "The Escape," Paul Armstrong's wonderful dramatic production, also produced in film version by Mr. Griffith, in seven reels, are the first two of these special features that will be sold in this way.

In an interview with H. E. Aitken, president of the Reliance and Mutual Film Corporation, Mr. Aitken said:

"I have always felt that such features as D. W. Griffith has produced are far too beautiful and wonderful to handle and to do justice to by so large an organization as I am associated with. When it is remembered that Mr. Griffith is considered to be the premier director of the picture business today; I have decided that really the only way to do justice to pictures of this calibre is to sell the rights to reputable state rights people who will exploit them in a manner befitting their importance.

"There have been so many state rights propositions on the market that have hardly come up to the average of the regular program material that it is time proper attention were devoted to this part of the industry. The state right field today is not unlike the small jobbing business of old, inasmuch as it is over-run with the riff raff of the industry. If more attention were paid to this end, or the end of purchasing proper and lasting subjects this branch of the business would not be looked down upon."

GREAT NORTHERN FILM COMPANY AT THE FRONT

THE German war office has just recently granted the Great Northern Film Company official permission to take pictures at the Franco-German front, is the announcement made by the company. This is considered quite a distinction, as, it is asserted, it is the first time any company has succeeded in obtaining permission to photograph actual battle scenes of the great conflict.

The Great Northern camera men went from Copenhagen to the seat of war in automobiles, accompanied by military escort. It is expected that some very remarkable pictures will be the result of this expedition, and it is the company's intention to continue taking pictures on the firing line for an indefinite period.

A series will be inaugurated, the plan being to release one reel of these war pictures at a time. The first scenes that have been photographed are now on the way to New York, and will be released within the next two weeks.

HARRIS TO CLEVELAND FOR BOX OFFICE

ZACK M. HARRIS has been appointed manager of the Cleveland office of The Box Office Attraction Company. Mr. Harris was formerly connected with the Shubert offices and the Klaw and Erlanger organization. He has covered the country in advance of big Broadway productions. Besides having a thorough knowledge of the theatrical business he is an old time newspaper man.

Harry P. Decker, formerly connected with a large Ohio feature film exchange, is now one of Mr. Harris' assistants.

Be sure to mention "MOTION PICTURE NEWS" when writing to advertisers.

ALL STAR FEATURES

CHARLES A. STEVENSON

in
"SHORE ACRES"

James A. Herne's Masterpiece
In Five Parts.

RELEASED OCT. 26.

Coming
DIGBY BELL

in
"The Education of Mr. Pipp"
TO BE RELEASED NOV. 26.

All Star Feature Corp.

220 West 42d Street New York



A. I. Raven Advertising & Sales Co., Inc., Successors to

Prices to the Trade
POSITIVE PRINTS .04 1/2 Per Foot
(In Quantities over 5000 feet)

Above price includes printing, developing, tinting, toning and Raw Positive.

Negative Film Developed .01 Per Ft.
Film Titles .08 " "

(Our Special Title Apparatus will match any perforation.) All work guaranteed.

General Offices, 2624 Milwaukee Ave., Chicago
Phone Albany 3125

Our Factory Is Yours!

Negative assemblers, projecting machines and an equipment second to none, with an organization of experienced people always at your SERVICE for DEVELOPING and PRINTING.

EVANS FILM MFG. CO.

Incorporated

416-22 WEST 216th STREET

Tel. 7652 Audubon at Broadway, New York

CLASSIFIED

SITUATION WANTED

OPERATOR (licensed), experienced, careful, open for position. Experienced booker. Young married man, country bred, strictly temperance, references. H. J. Campbell, Deep River, Ct.

Are You Having Booking Trouble?

Are you getting the films you want—or are paying for?

Save trouble, time and money by booking your films through the

Managers Booking Bureau

Suite 1012, Hartford Building, Chicago
Phone—Central 2448

Motion Picture Booking for the States of Illinois, Indiana and Michigan.

Films Reviewed.
Exhibitors' Supply Service.

Information regarding any branch of the Motion Picture business

Write now for particulars.

Your negative developed, printed and tilted complete
5¢ delivered per foot within 12 hours

Titles 6¢ per foot

GUNBY BROS., Inc.
145 West 45th Street New York City

Please Do Not

fail to notify the News if you change your address. You lose the full value of your subscription if you do not get every issue

Cosmofotofilm Co



London Film Co.
(Trade Mark)

"Where the Real Features Come From"

"She Stoops To Conquer"

A Classic Dramatic Comedy in 4 Parts
For Exclusive Rights, Address us at

World's Tower Bldg., 110 W. 40th St., New York

Warning to Exhibitors

KEYSTONE films have become so popular that unscrupulous dealers are at work again selling dupes throughout the country. The only genuine KEYSTONE films are those rented exclusively in the United States and Canada through the Mutual Film Exchanges. This Company will ferret out and prosecute and punish to the extent of the law, those duping KEYSTONE films or exhibiting dupes.

THE KEYSTONE FILM COMPANY A. KESSEL, Jr.
President
LONG ACRE BUILDING Broadway and 42nd Street NEW YORK CITY

Your Equipment As An Exhibitor Is Not Complete
until you become a constant reader of

ACCESSORY NEWS

Study Pages 69 to 82 in this Issue and see WHY



1915 Revised Simplex Equipment 1915

NOW READY FOR DELIVERY

\$300.00 Another Advance In Quality **SAME PRICE \$300.00**

NEW STANDARD MAGAZINES and TAKE-UP

Drawn from No. 18 gage steel in two pieces, inside diameter 16", accommodating any size reels.

Improved malleable iron strap hinges 7½" wide, equipped with spiral spring and a substantial spring latch. (Underwriters' requirements for all motor driven machines.)

LOOK

through the 3" x 4" x ¼" wire glass window in the upper magazine. The film can be seen without opening the door, thereby reducing the fire hazard.

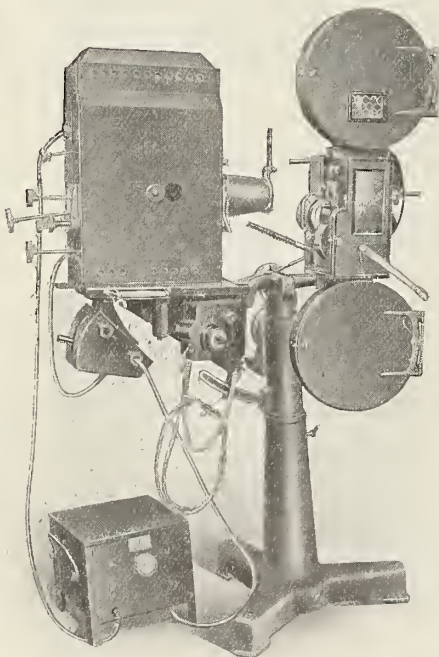

TAKE-UP

furnished with a reversible pulley to permit the use of regular small hub reels or Bell & Howell special with 5" hubs, recommended for 2000 ft. Two belts go with each machine and two small reels and the new pulley.

OPTICAL SYSTEM:

Your option—No. 1 Gundlach or Crown special Motion Picture objective. Achromatic two lens single combination and one set of imported optical glass condensers.

RHEOSTAT:

Enclosed 110 Volt approved grid adjustable, increased to 50 amperes capacity.

Catalogue No. 4 explains concisely why Simplex projection cannot be imitated.

MADE AND GUARANTEED BY

THE PRECISION MACHINE CO. INC.

317 East 34th St. New York

NOVEMBER 14, 1914

Accessory News

THE CONSTRUCTION, EQUIPMENT AND OPERATION OF THE MODERN MOTION PICTURE THEATRE

VOLUME X

NUMBER 19

CONTROLLED BY ATSCO

The control of the RADIUM GOLD FIBRE SCREEN is vested solely in us. Any other combination of words which will imply to the exhibitor that he is buying a

RADIUM GOLD FIBRE SCREEN



when he is *not*, is a deception. A deception is a fraud. A fraud is a misdemeanor. A misdemeanor is punishable under the law. We cannot be accused of deceiving. We cannot be charged with fraud. We are not liable for a misdemeanor, when we say that there is no screen on the market which can approach the qualities which are possessed by the RADIUM GOLD FIBRE SCREEN—Clearness, Brilliance and Perfection. We won't bet you. We won't threat you. But those who have the RADIUM GOLD FIBRE SCREEN in their theatres won't let you contradict this statement.

Everything for the Theatre

ATSCO, Inc.

ALCO FILM CORPORATION, 218 West 42d St., New York

BETTER LIGHT

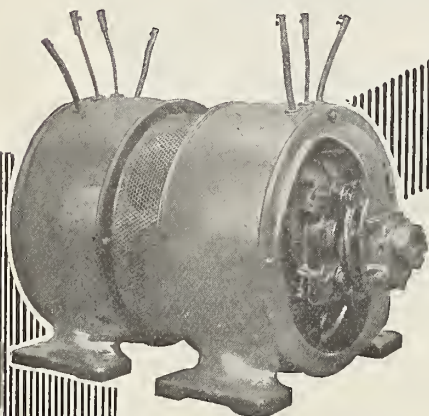

The DC Compensarc lowers the voltage of a direct current supply to that required at the lamp without needless waste.

LESS CURRENT

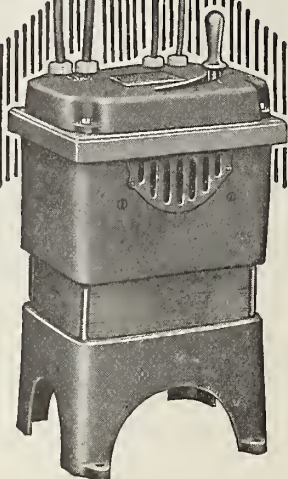

The AC Compensarc cuts $\frac{2}{3}$ from your lighting bill if you use alternating current.

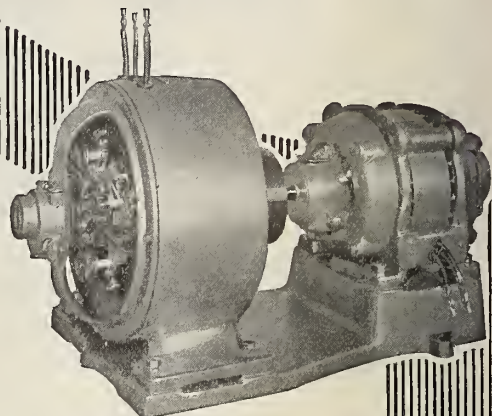

The AC to DC Compensarc will transform alternating into direct current and reduce the voltage at the same time without need less waste.

No matter what current you have---Alternating or Direct---or what voltage or frequency, one of the

FORT WAYNE COMPENSARCS

will enable you to secure a light that will give those clear, bright pictures that everybody now demands.

What's the use of paying extra money for special screens, projecting machines, and first run films and then spoil the whole result with poor light? With the Fort Wayne Compensarcs you can get any kind of light you want regardless of the kind or quality of your current supply.

The Compensarcs will give you

STEADY LIGHT. No flickering, no sputtering, even when changing intensities or from one machine to another.

WHITE LIGHT. No yellow streaks, no ghosts.

BRIGHT LIGHT. Three times the light with two-thirds the current.

They are safe, efficient, easy to operate, fool proof and reliable.

FORT WAYNE ELECTRIC WORKS

OF GENERAL ELECTRIC COMPANY

1704 BROADWAY

FORT WAYNE, INDIANA

Compensarcs are so commonly found in motion picture theatres that many people now call all current saving and transforming devices by that name.

But Remember

*If it isn't a FORT WAYNE
it isn't a "COMPENSARC"*

*Send TODAY for this
FREE descriptive booklet*



Construction,
Equipment,
Operation

Accessory News

Everything for
the Modern
Picture Theatre

Tel. 7650 Bryant

NO. 220 WEST FORTY-SECOND STREET

New York City

Volume X

NOVEMBER 14, 1914

Number 19

What "Accessory News" Means

THIS is the day of the modern picture theatre, finely and fully equipped, and efficiently run.

Which, briefly, is the reason why we have added "Accessory News" to MOTION PICTURE NEWS.

* * *

WE have been planning "Accessory News" for some time.

It has seemed to us that such matters as theatre construction, equipment and operation are important enough to demand a new magazine devoted wholly to this field.

We have felt that they deserved more than a mere department and much more than casual editorial interest—that they should, by no means, be pushed out of sight by the mass of film news, reviews and advertising.

* * *

SO we hit upon the idea of "Accessory News."

It is not separate from MOTION PICTURE NEWS, but it is, nevertheless, a magazine within itself.

It has its own manager and its own separate staff of writers.

It has its own cover or title page in color and in every way is made to stand out prominently and distinctly as it should.

* * *

IT is the writer's opinion that "Accessory News" will grow till it rivals—and perhaps outdoes—that part of MOTION PICTURE NEWS which is devoted to pictures and picture making.

The making of pictures is of the utmost importance. But so also is the showing of pictures. The latter problem, however, has fallen far short of the attention it deserves.

* * *

A MAKER of screens has shouted insistently, for the past several years, that what the exhibitor is really retailing to the public is *picture light*.

So he is.

He doesn't merely retail pictures. The best pictures ever produced are of little use to him—they will not gain and hold patronage—unless they are well projected on the screen and well reflected from that screen.

* * *

IN other words, the successful exhibitor is the man who also sells good picture light.

He must sell other things, too, beside pictures.

He must sell an attractive and comfortable interior, which means a great many things, such as ventilation, pleasing lights and decorations, comfortable chairs, excellent music, courtesy from employees—service and efficiency *all along the line*.

And to bring his patrons in, he *must have* an attractive lobby.

THE lack of all this may have been well enough in the days when theatres were only converted shops, when exhibitors were merely speculators with a new and untried amusement; but today these elements of theatre service and efficiency are *necessities*.

The public has been educated up to well-shown as well as well-produced pictures.

They *demand* a pleasing environment. Among the exhibitors of the country, a stern survival of the fittest is in progress of which the mismanaged, poorly-equipped theatre is fast dying and by which the modern picture theatre finely and fully equipped is becoming more and more of a big and important institution.

* * *

A GAIN, there is the growing importance of motion picture technique.

All the faults of projection today are charged upon the projection machine and the screen.

These important facts are not taken into account: that we have no standardized methods of film perforation, camera work, developing and printing, etc.

Until we achieve this standardization, we shall not have perfect picture light.

* * *

THEN, too, among other things, is the question of furnishing and equipment contributing to the comfort of patrons. The right kind of seating has a great deal to do with attendance, and its importance has commanded the attention of manufacturers.

It has been a long way from the crude chairs of the "store shows" to the luxurious upholstered seats of the present motion picture theatre.

* * *

PROPER decoration is now recognized as a big asset in a theatre's popularity. The highest skill is employed in rendering the walls and ceilings pleasing to the most critical eye.

The best carpets and draperies, formerly used only in the more pretentious places of amusement, now grace the temples of the new art.

The demand for furnishings of this character from motion picture theatres has considerably augmented the business of firms in this line, and called upon the services of experts who make a specialty of estimating on the outfitting of photo play houses.

* * *

"ACCESSORY NEWS" aims to take up all these important matters—competently and continuously—for the benefit of the progressive exhibitors and operators, for the prospective theatre builder—and for the betterment, we trust, of the problem of picture exhibition.

WILLIAM A. JOHNSTON.

The New Era in Film Construction

Peculiar Requirements of Motion Picture Houses, Since the Establishment of Photo Drama on a Permanent Basis in the Amusement Field Have Made Necessary a Class of Architects Who Study the Needs of the Exhibitor—The National, of Los Angeles, Built by Valk Brothers, an Example of This Type

THE permanency of motion pictures in the amusement field has resulted in specialization on photo play theatres by architects. Expert planning, based on the peculiar requirements of picture houses, has solved for the exhibitor numerous problems formerly confronting him in the erection of a satisfactory theatre building.

The specialist devises ways and means for his clients whereby the cost of construction is materially reduced without sacrificing any essential requirement to cheapness. In numerous cases owners

reason a manager negotiating with the owner of a piece of property for the lease of a proposed theatre, finds a dollar-and-cents interest in the qualifications of the architects submitting specifications.

Consequently a manager in consultation with an owner for the purpose of making suggestions should be familiar with the capabilities of various architectural firms likely to draw plans for the theatre. Under those circumstances, a word in the right direction would mean less expensive and more efficient work—and an ultimate saving to the manager as well as the owner of the property.

The same thing applies to the remodeling of a motion picture house. Anybody can figure on alterations, but only a specialist is able to give satisfactory service at the minimum expense.

A firm knowing the requirements of motion picture theatres is that of Lawrence B. and A. Lawrence Valk, of Los Angeles, Cal. They have gained a reputation as "theatre specialists" extending beyond their own state.

These architects have planned numerous picture houses causing wide comment for the up-to-date ideas embodied in the structures.

A recent example of their success is evidenced in the new National Theatre of Los Angeles, one of the handsomest and best equipped in the State of California.

A glance at the illustrations of the exterior and interior views and a scrutiny of the ground plans will bear out the commendation of local residents.

This firm is prepared to supply clients with complete plans, details and specifications of theatre buildings of almost any size, ranging in cost from \$12,000 to \$100,000.

The National has been built on a site costing \$200,000, and the cost of the structure amounted to \$19,000. The lessee pays an annual rental of 10 per cent., or \$1,825. His fixed charges are reduced, however, to about \$875 per month by the privilege of renting three stores, netting him about \$950 a month. As the building is located in the business section the stores are practically never vacant.

The building is 60 feet wide by 140 feet long, and is built entirely of brick with white artificial stone front, and cost complete, without the opera chairs, stage scenery, carpets, curtains and draperies and the electric signs, and projection machine, \$19,000. This included the sidewalk for the entire front, 12 feet wide; also the bill boards at the curb. The exterior lobby is 20 feet wide with octagon plate glass box office in copper frame. There are also eight one-sheet poster frames with glass doors, four on each side of the lobby.



THE NATIONAL THEATRE, LOS ANGELES

have been saved money on buildings which if planned by the average architect, would far exceed reasonable figures. Such a saving amounts to no insignificant sum with the price of building material mounting higher and higher.

The reduction of construction cost to the lowest possible level means a great deal to the exhibitor. The owner, in basing the rental of the theatre to the manager, is naturally influenced by the first cost of the building. If the architect saves him a few thousand dollars he is disposed to ask for less rent. For this

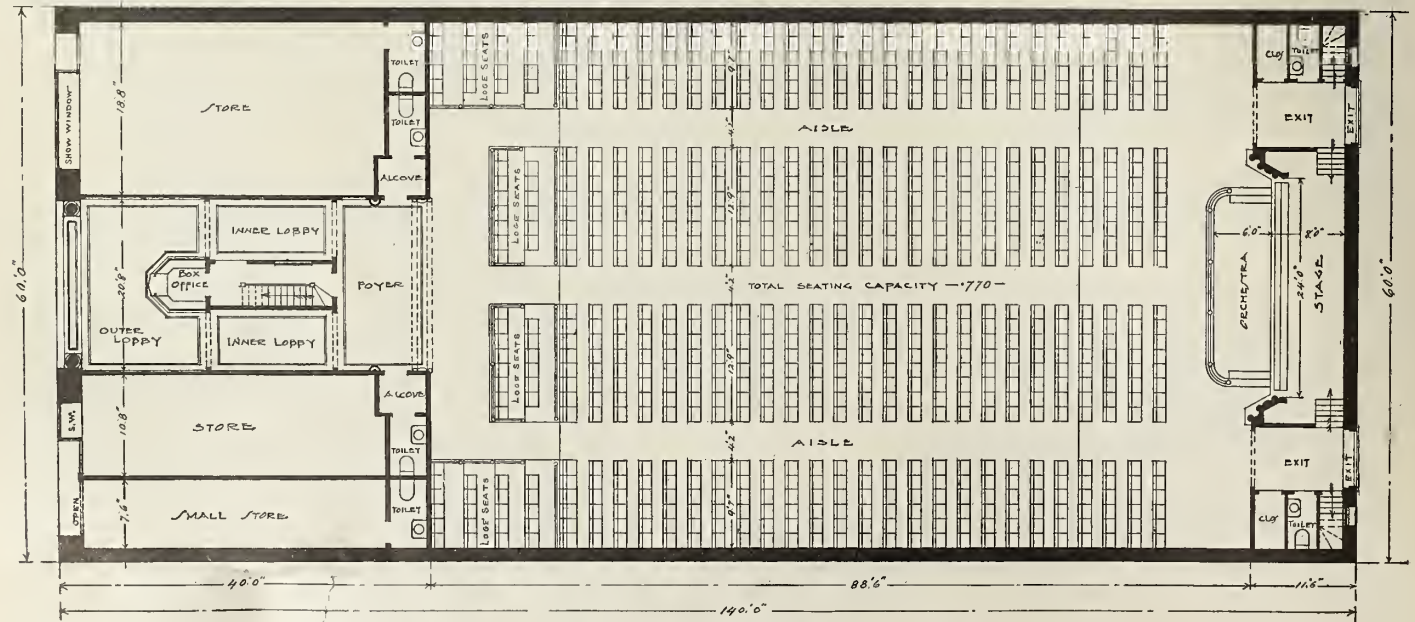

PLAN OF THE MAIN FLOOR, NATIONAL THEATRE, LOS ANGELES, CALIFORNIA.

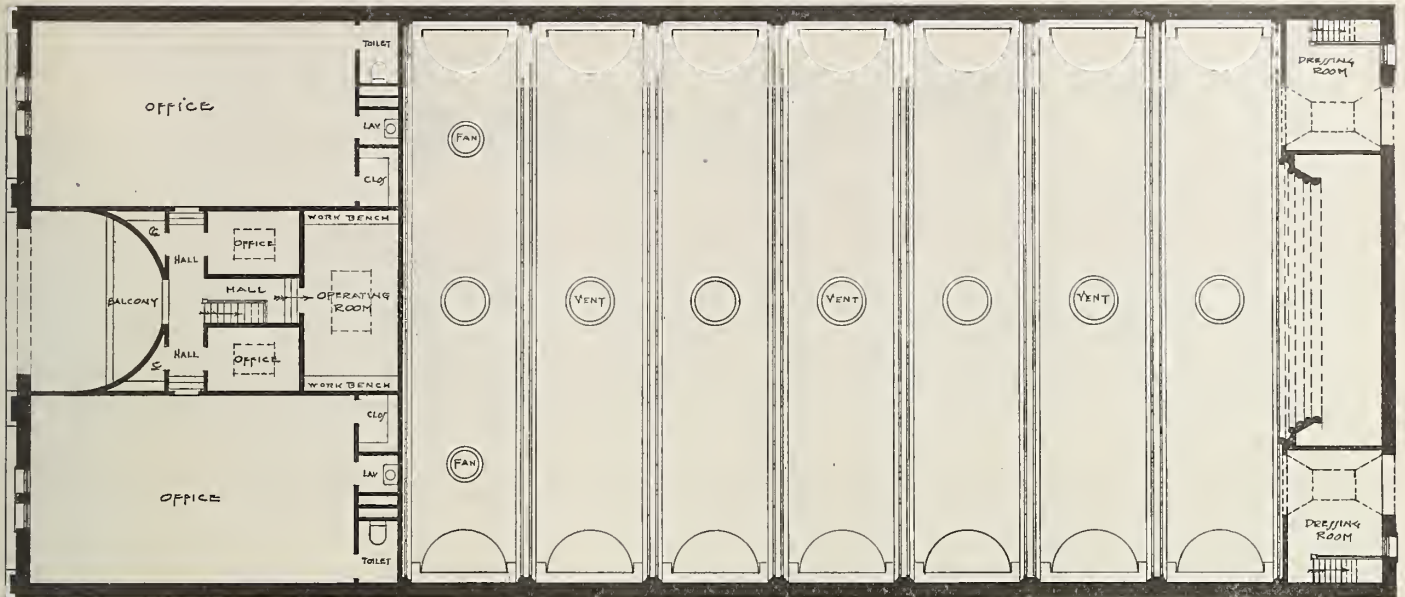

PLAN OF THE SECOND FLOOR, NATIONAL THEATRE, LOS ANGELES, CALIFORNIA.

The lobby is lined all around with marble, three feet six inches high, including the box office. There is a balcony suitable for a band of music directly over the box office. There is also a large foyer back of the box office, with toilets for men and women, and every convenience for the public.



INTERIOR, NATIONAL THEATRE, LOOKING TOWARD THE SCREEN.

The operating room is directly over the foyer and is nine feet wide by 20 feet long. The equipment consists of two Power's 6-A machines, one dissolving stereopticon, one spot light, and a motor generator set. All the lights on the stage, such as foot lights, border lights, are controlled from the operating room on dimmers, so they can be raised and lowered at will; likewise the indirect lighting system in the ceiling of the main auditorium of the theatre.

There is also a stage switch board which controls the lights on the stage separately if desired. The ventilating system is by the intake and exhaust system, consisting of two intake and two exhaust electric fans, which supply the required amount of fresh air to each person in the audience.

The theatre has a total seating capacity of 760. An indirect lighting system consisting of X-ray hanging fixtures is part of the equipment.

The emergency lights are in small baskets in cusps, readily seen in the interior views.

A Universal program is in use, and the admission price is five cents.

REGULATING THEATRE TEMPERATURE

WITH a temperature of 110 degrees outside it is possible to keep within the theatre at 75 degrees, with the humidity at only 50 degrees. This same principle works in cold weather with the heating system.

In cooling the theatre the fresh air which is taken in at the top of the building goes direct to the basement, where it passes through an air washer of 14,000 cubic feet capacity. This consists of a succession of sprays of cold water between which run pipes connected with a carbon dioxide ice-making machine exactly similar to those used in a cold storage warehouse.

The air, which has had all the dust and dirt taken out of it by the water and cooled to the desired temperature, is passed into the theatre under each of the seats at a rate which will entirely change that of the entire house in ten minutes or less, according to the size of the house. The foul air is taken out through the roof by means of ventilators in which motor-driven fans are installed with the same capacity as those on the intake.



AUDITORIUM, NATIONAL THEATRE, FROM THE MUSICIANS' PIT.

The heating arrangement works in the same manner as the cooling, except that the air, after passing through the spray, goes over heated pipes and is then sent all over the theatre.

The great advantage of this system is the fact that the air is absolutely free from dust and dirt.

This system has been installed in many of the progressive houses by the B. F. Sturtevant Company, of Boston, with great success.

Projection

Editor's Note.—This important department of projection—optical, mechanical, electrical—will be conducted by well-qualified experts, assisted by contributing editors, whose names are well known as authorities in the projection field. The following subjects will be taken up and thoroughly covered:

New Apparatus and Accessories; Interesting Experiences of Operators; Well Arranged Booths; Making of Announcement Slides; Best Methods of Setting Carbons; Operating Kinks; Screen Mediums; Condensing Lenses; Carbons; Rheostats; Best Results from A. C. Current; Examination of Operators in the Different Cities; The Care of Economizers; Testing the Efficiency of an Economizer; Handy Conveniences in the Operating Booth; Ventilation of Booths; Determining the Equivalent Focus of Lenses; Film Cements.

The co-operation of the reader is urgently needed to make this department attain the success we have planned for it.

Write to us and give us any news or views you have upon the above subjects and never hesitate to lay before us any problem upon which you want advice.

To Which Wire Should the Rheostat be Connected?

By Herbert S. Andem

WHY should this question puzzle any operator? Still it has, and very recently at that. A licensed operator of long experience was unable to answer in the affirmative, when asked if it made any difference to which wire a rheostat is connected.

(a)

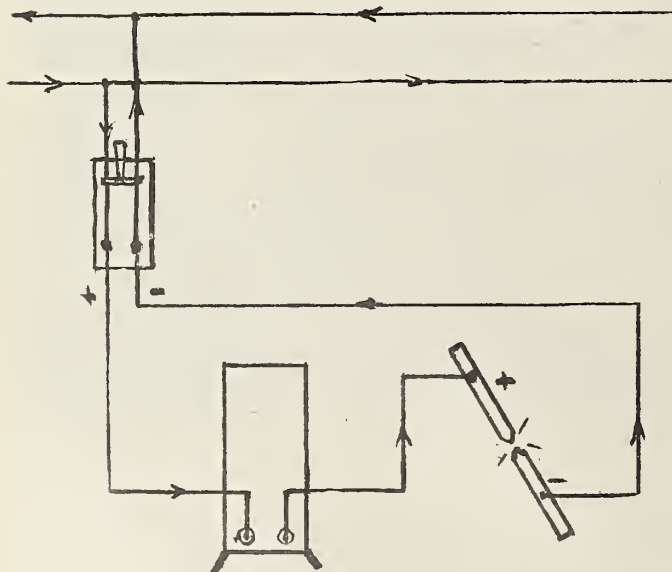

If one has a clear understanding of the principle involved in current flowing in a simple closed circuit, there should be no time lost in answering this question. Ohm's Law, given in books on

elementary electricity, may be stated in these words: That the current is the quotient by dividing a resistance to the flow of current by the pressure against it, and clearly implies that in a simple closed circuit the current must be of the same strength in all its parts.

Then we cannot have, say, 50 amperes at the carbons and only

(b)

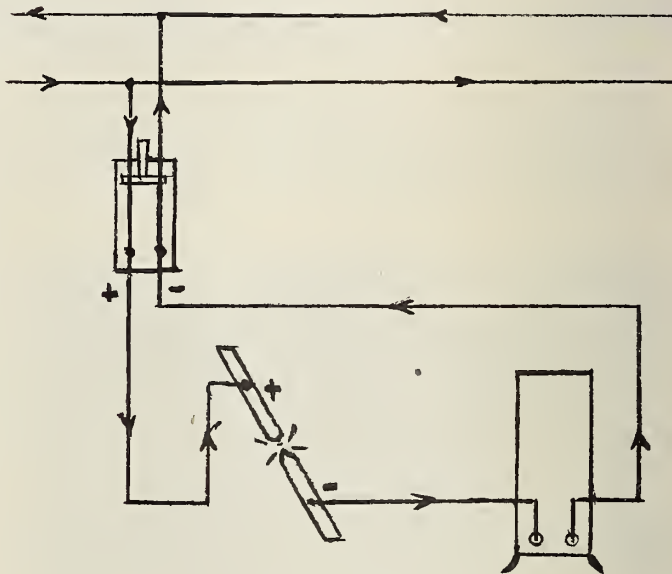

25 amperes in the rheostat, when the positive wire is connected directly to the carbons, and before it passes to the rheostat. For, according to this law, governing the strength of current in a closed circuit, it has to be the same in all its parts.

Any operator can easily verify this fact by the use of an ammeter, if he is fortunate enough to possess one. First, connect the ammeter in series with the circuit at the switch on the positive wire, then in series with the other, or negative, wire. It may also be connected on either side of the rheostat. The several readings will be the same, provided the separation of the carbons is the same at the time of taking each reading.

That part of a moving picture circuit within the operating booth where the rheostat is generally connected is represented in diagrams (a) and (b). This part of wiring a machine the operator has to do. And here the operator connecting up a machine may ask himself which wire goes to the arc lamp and which goes to the rheostat.

Starting with the positive wire marked "plus" in diagram (a) the current goes in the direction indicated by the arrow directly to the rheostat. After passing the rheostat it goes to the positive carbon of the arc lamp, across the arc to the lower carbon, back over the other wire into the circuit.

The resistance within the rheostat checks or limits the current, and the current flowing is of such a strength as the resistance allows to pass, plus the resistances of the wire and the arc. Generally this combined resistance of the wire, rheostat and arc limits the current approximately to 25 amperes.

Referring to diagram (b) we see that the current goes directly to the carbons, and then passes on through the rheostat. The

(Continued on page 76.)

MOVING PICTURE THEATRE MAILING LISTS FOR SALE
 20,192, covering United States and Canada, Price \$40.00, or \$3.50 per thousand for such states as you want.

795	Film Exchanges, U. S.	\$3.50
70	Manufacturers and Studios, U. S.	1.00
34	Moving Picture Machine Mfrs. and Dealers.....	1.00
231	Film Exchanges, Foreign Countries.....	3.00
520	Moving Picture Theatres, Foreign Countries....	3.00

Ask us for full particulars.

TRADE CIRCULAR ADDRESSING CO.
 166 West Adams Street, Chicago
 Established 1880

We Can Equip Your Theatre Complete

We are Distributors for the Powers, Edison, Motiograph and Simplex Machines, and Genuine parts, also Poster Frames, Indirect and Semi-Indirect Lighting Fixtures, Tickets, Screens, etc.

We sell for cash or on the easy payment plan.

Write today for our new catalog just off the press.

AMUSEMENT SUPPLY CO.
 160 No. Fifth Avenue Chicago, Illinois

A clear picture

is as essential as a good scenario. Because the basic product is right the clearest pictures are on Eastman Film. Identifiable by the stencil mark in the margin.

EASTMAN KODAK CO.,
 ROCHESTER, N. Y.

**Increase Picture Quality
 Increase Your Profits**

Picture patrons are critical of the films you show them. They know good quality, and they go where it is found. Along with good film service, you must have efficient lens equipment to hold your steady patrons. One sure way is to use

**Bausch^{and} Lomb
 Projection Lenses**

The finest detail in every picture thrown on the screen, together with illumination of the utmost brilliancy, are assured when Bausch & Lomb objectives are used.

Regularly supplied with Edison and Nicholas Power Machines.

Send for our interesting free booklet for owners and operators.

Bausch & Lomb Optical Co.
 569 ST. PAUL STREET ROCHESTER, N. Y.

MOTIOGRAPH
 FLICKERLESS PROJECTOR

MOTIOGRAPH
 SATISFACTION

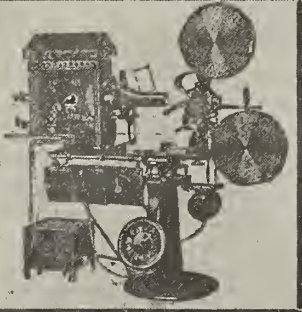

MOTIOGRAPH
 SIMPLICITY

MOTIOGRAPH
 SMALL UP-KEEP

MOTIOGRAPH

Projection is Unexcelled

Note the sharp, clear pictures—compare them with other machine projections—see for yourself. There is a vast difference in the Motiograph projection and when you speak of upkeep—the MOTIOGRAPH has no equal. It's hardened parts will last many years longer which is spoken of by all users.

THE ENTERPRISE OPTICAL MFG. CO.
 568 W. Randolph St., Chicago, Ill.

Eastern Office
 21 E. Fourteenth St., New York

Western Office
 833 Market St., San Francisco

TITLES

Our *Title Department* has been re-organized, elaborately equipped and placed under the direction of recognized experts.

Its highly perfected apparatus, linotype machine and job presses enable us to produce the most difficult title work in any language—artistically, accurately and *quickly*—and at *lower prices* than have ever yet been quoted.

DEVELOPING AND PRINTING

Save money and insure the best results by entrusting your work to the *largest and most complete commercial plant in America.*

CENTAUR FILM CO.

Bayonne, N. J., and 1600 Broadway, N. Y.

FOR SALE ^{4 Moving} Picture Cameras **TRIPODS**

A bargain if you want one

Industrial Moving Picture Co., 223 W. Erie St. Chicago

MENGER & RING

302
W. 42nd
Street
New York

TELEPHONE
BRYANT 6621

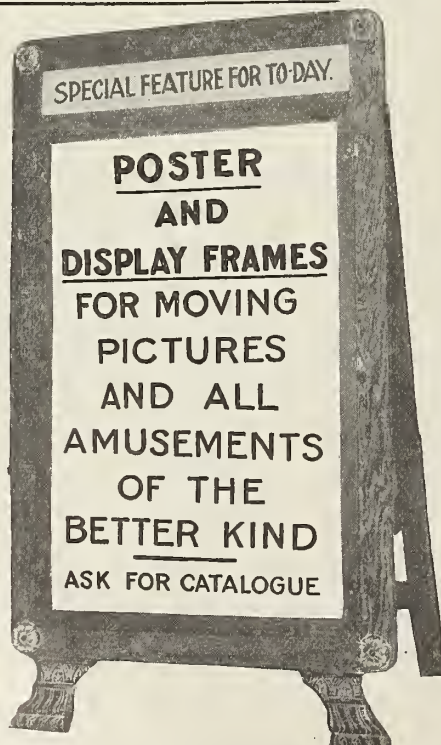

To Which Wire Should the Rheostat Be Connected?

(Continued from page 74.)

combined resistance is identically the same as in diagram (a). So it makes no difference whether the rheostat is connected in before the current reaches the arc, or after it has passed it; there cannot be more amperes at the arc than in the rheostat.

Whenever the circuit is closed by touching the carbons together, and then separating, as is the usual practice, a current of electricity flows over the positive wire and endeavors to return to its source over a path of the least possible resistance.

The current finds but one path to follow, and this is over the copper wires. These wires lead through the rheostat in both cases, no matter where it is connected, and is always a part of the circuit. If it *did* make any difference to which wire, positive or negative (plus or minus) the rheostat was connected, what would happen when using alternating current? It then would mean there would be more current at the carbons when the current was flowing in one direction, and less when the direction was reversed. This is not the case, as operators know.

A case can be recalled where the rheostat was located on the stage near the switchboard, and the wires were run to the balcony to a machine located there. This was before the days of operating booths.

Such an arrangement was made to facilitate matters in the balcony, and to avoid danger of fire from loose film touching the rheostat. In those days the operator stood knee-deep in film after a show; no take-up reels were then used. So it does not matter even if the rheostat is more than a hundred feet away from the lamp. It is a part of the circuit, and the current has to be of the same strength in every part of it.

A bucket having a small valve located on the side near the base is filled with water. This valve has a small opening, and offers a certain resistance to the flow of water from the bucket.

The valve may represent the rheostat, and the flow of water the flow of electricity in a circuit. Now suppose this valve be taken from the bucket; then a short length of pipe inserted, with this same valve placed at one end, instead of at the base of the bucket. By such an arrangement, when the valve is open, the flow of water between the bucket and valve is no greater than before, even if this pipe be of any length or of any diameter. The flow or quantity of water passing the valve within the pipe can be no greater than this valve allows.

The valve is the resistance, and regulates the flow of water. The flow of water within the pipe is governed thereby, though there is comparatively no resistance to its source of supply, the bucket. Its only path leads through the valve.

INSTALLATIONS OF POWER'S MACHINES

POWER'S projection machines have recently been installed as follows:

Boston Opera House, Boston, Mass., two Power's Cameragraphs No. 6A; Globe Theatre, Montgomery & Stone production of Chin-Chin, musical comedy, New York City, one Power's Cameragraph No. 6A; Y. M. C. A. of Bristol, R. I., one Power's Cameragraph No. 6A; The Central Museum of Brooklyn, New York, one Power's Cameragraph; The New York *American*, New York City, one Power's Cameragraph; the Santa Fe Railroad, Los Angeles, Cal., Safety Department, one Power's Cameragraph No. 6A; the New York Central & Hudson River Railroad, Safety Department, New York City, one Power's Cameragraph No. 6A.

NEW SIXTH STREET THEATRE OPENS IN ST. LOUIS

THE Strand, a handsomely appointed all picture theatre on Sixth street between Locust and St. Charles, St. Louis, opened Monday, October 26. The new house seats five hundred people, uses a five and six reel General, Universal and Mutual first run program, changes daily, and charges ten cents admission.

The Strand is next door to the Columbia Theatre, the leading vaudeville house of St. Louis, and within six hundred feet of three more moving picture houses, but since its location is in the heart of the downtown shopping district, in the middle of the busiest blocks in town, it is assured of a good patronage.

H. D. Buckley is manager and Chas. J. Vollmer, former manager of the Princess, at Grand and Olive, before that theatre went over to burlesque, is the assistant manager.

Building and Furnishings

Apollo, a Model Theatre

THE Apollo Theatre, Peoria, Ill., is one of the handsomest and best equipped houses in the state. Its every appointment has been studied with a care shown by the results of the completed structure. The cost complete at the day of opening figured \$86,000.

The designer has taken excellent care that the ground occupied by the theatre should have a definite income aside from that of the theatre in order to defray overhead expenses. The ground floor has a store on either side of the lobby, and the two upper floors directly over the lobby is given over to offices. The entrance as shown in the accompanying photograph is plain as compared with the interior, though this very plainness adds to its attractiveness and drawing power.

The interior, as shown in the illustration looking toward the stage, is unique, for it is faced with dark brick. Another unique feature is the gray stone pillar on each side and the arch about the stage. This whole effect gives the lower part of the theatre a dark appearance except right around the stage, which is instinctively the focus of vision.

This is overcome by the distinct contrast of the ceiling, which is white, and, with the indirect lighting, reflects a beautiful soft light throughout the house. The darkness of the lower part is relieved by beautiful paintings, by Gustav A. Brand, of Chicago,



SOME OF THE MURAL PAINTINGS IN THE APOLLO THEATRE

along the general style of Maxfield Parrish's work. This lends a striking contrast to the general decoration of the average picture house. The exit facilities are amply taken care of by a double door on each side of the stage, as well as a large side exit.

The chairs, which number approximately 900, are of oak finish, upholstered in leather with sides of fancy wicker work. These were supplied by the Wisconsin Seating Company.

The projection room, which is above the balcony, is well equipped, containing two Motiographs, 1914 models, and other

electrical equipment which are necessary for the up-to-date picture house. The use of these two machines allows an uninterrupted showing of features.

The stage, of considerable depth, is equipped with a mirror screen 16 x 18 feet, from which fine results are being obtained. The decoration about the screen, which is so essential in properly setting off the picture, is admirably taken care of. Vines have been used most artistically wound into a lattice work in a way which gives the appearance of an arbor.

The "Washed Air Purifying System" has been installed with the result that the theatre is cool during the summer and amply warm during the winter. By ventilating the theatre in this way and passing the air through a series of sprays, all dust and dirt is taken away and the air becomes absolutely pure. This is an asset to any house and should not be overlooked when remodelling.

The lobby is finished in mosaic blocks with marble columns. Mirrors are placed at intervals on the wall. This form of decoration is becoming more popular and adds greatly to the effect.

THEATRE DE LUXE IN ST. LOUIS

THE West End Lyric Theatre, at Delmar and Euclid avenues, St. Louis, is the dernier cri in motion picture houses. From the embroidered cable net curtains that adorn the glass doors of the lobby back to the screen, the furnishings and equipment is characterized by elegance and good taste.

The lobby is particularly pleasing; there are three Oriental rugs on the mosaic floor, a large Etruscan vase filled with ferns and living foliage, flanked on either side by smaller urns, and in the foreground a receptacle that is replenished daily with cut flowers.

The house seats eleven hundred persons, and gives a program of high class features. A five piece orchestra and a Victrola furnish the music. Mrs. J. W. Cornelius is the manager.

A new five hundred seating capacity theatre is being planned for the southwest corner of Jefferson avenue and Hickory street, St. Louis.

OPERATORS' BALL SET FOR NOVEMBER 7

THE third annual ball of the Moving Picture Machine Operators' Protective Union, of Greater New York and vicinity, local 306, I. A. T. S. E. of the United States and Canada, will be held at the Palm Garden, 58th street and Lexington avenue, New York, Saturday evening, November 7.

Neither time nor money has been spared in the effort to make this event the one big affair of the season. All the leading manufacturers will be represented and prominent stars of the photoplay world will be present in person. The city officials have been invited as well as the international officers of the I. A. T. S. E. In fact, Local 306 have never as yet made an effort to do anything quite so ambitious in the social line.

A MILLIONAIRE'S THEATRE

THE new motion picture theatre on Colorado street, at Pasadena, Cal., being built by Frank Dale, of that city, will be opened some time between November 15 and the first of December, under the management of Jack Root, a well known Los Angeles man familiarly known in sporting and financial circles.

Life Size Lobby PHOTOGRAPHS Boost Box Office Receipts

Original negatives of leading players of all West Coast studios in straight or character poses.

DISPLAYS NOW READY*

DISPLAYS OF COMING RELEASES

The Spoilers
St. Elmo
Little Sunbeam

The Avenging Conscience
Will O' The Wisp
The Hoosier Schoolmaster

The Blood Red Rose
Terrance O'Rourke Series

The Carpet From Bagdad
The Rosary

SIZES: 8x10's, 16x20's, 30x40's, and 30x60's. Introductory offer closes December 1st. WRITE NOW.

PHOTOPLAYERS' STUDIO

342 SO. BROADWAY

LOS ANGELES, CAL.

Only exclusive professional studio on Pacific Coast where 80 per cent. of American motion pictures are made.

Directory of New Theatres

EDITOR'S NOTE.—The information contained in the "Directory of New Theatres" is gathered by the field representatives of "The Motion Picture News" and the facts and figures in each instance have been verified by them and are authentic. They may be relied upon by members of the trade.

THEATRE BUILDING BOOM IS ON IN MILWAUKEE

MILWAUKEE is experiencing the first throes of its annual fall photoplay theatre building boom. Simultaneously with the first touch of frost come the announcements of new theatres and alterations to the value of \$84,000.

All of the new houses will be of the latest and most perfect type of photoplay theatres as the building requirements are very strict and the men who are putting their money into the houses seem to be anxious to put up buildings that will be of credit to the moving picture industry.

John Radtke will erect a theatre at the corner of Astor and Brady, costing \$25,000, while H. Trinz will erect a house with seating capacity for 1,026 and costing a like amount at Twenty-seventh and Center streets. The permit for this house was taken out by A. Peters, as announced recently, and though he is interested in the house it will be run by Mr. Trinz, well known as an exhibitor in that city.

C. F. Mertz is erecting a house to cost \$12,000 at the corner of Hopkins and West Twenty-fourth streets.

Samuel Mergoleus will spend \$8,000 for alterations on his Olympic Theatre at Walnut and Eighth streets, while A. Trinz will spend \$14,000 for alterations on the Rainbow Theatre, Twenty-seventh street and Lisbon avenue.

Mr. Trinz is enlarging his theatre, adding 350 seats to his present capacity and putting in a stage.

HANDSOME HOUSE TO BE BUILT IN MINNEAPOLIS

GROUND has been broken for a new theatre, at Fourteenth avenue southeast and Fourth street. This new theatre will be built by Mr. Harry H. Green, president of the Motion Picture Exhibitors' Association of Minnesota, also president of the Crystal Theatre, Minneapolis.

This new theatre will have a seating capacity of 900, and its advantage will be that each and every one of the 900 seats will be on the ground floor. Judging from the architects' plans, this new theatre promises to be one of the most beautiful houses in the outskirts of Minneapolis or any other city of its size in the country. The opening is expected to be a gala one.

THEATRES HERE AND THERE

LESTER J. OSBORN has started to lay the foundation for the new moving picture palace on the board walk, Beach Haven, N. J., to be completed by June 1, 1915. There will be stores and flats in front of the theatre building proper, and it is expected to cost in the neighborhood of \$15,000, including the land.

Swampscott, Mass., will have its first moving picture house in Railroad avenue, nearly opposite the Boston & Maine railroad station. Harry B. Lombard, from plans by Penn Varney, will erect the building and lease it to Allen B. Newhall, manager of a Lynn theatre, and George H. Newhall, his brother, will be the manager. The building will be of brick and have a seating capacity of about 750. It will be ready for occupancy in November.

Permits have been issued by the city building inspector, of Milwaukee, Wis., for the construction of a \$25,000 theatre at Astor and Brady streets and for the erection of another one, costing \$10,000, at Twenty-fourth and Hopkins.

Arthur Greene, former supervisor, will build at Twenty-fourth and Hopkins and the theatre on the Northeast side will be put up by John Radke.

The Gem theatre, a new house in Charleston, Mo., is soon to be opened, under the management of J. E. Loeb, formerly of Sikeston, Mo. The new theatre will have a new Simplex machine, and will have a seating capacity of 300.

Plans have been drawn for a new moving picture theatre seating more than 1,000 people, to be erected on Franklin street, near Public Square, Watertown, N. Y., within a few months. It is said that the new theatre will occupy the site above the Lamon block in Franklin street. It will be two stories high.

Gulfport will in about six weeks or two months have another moving picture show if the plans of its two promoters, C. A. Simpson and Saul Streiffer, are successful, as they feel certain will be the case. These two men have been working out the details of the proposition for some time past and their enterprise is beginning to assume tangible form.

According to the promoters, only first class films will be shown, the men having made connection with a reliable New Orleans moving picture exchange. In addition to moving pictures, there will

be shown at the new house in all probability vaudeville acts.

A new motion picture theatre to cost \$3,500 will be erected at 1607 Plymouth avenue, Minneapolis, Minn., according to a city building permit issued recently to J. E. Anderson and H. A. Winperis, owners. The building will be 115 feet deep with 45 feet frontage, and of frame and plaster veneer construction.

St. Paul, Minn., councilmen, after listening to a long and acrimonious discussion, went on record recently as favoring motion picture theatres on streets that have been devoted to a considerable extent to business, and granted to C. L. Graham a license for a motion picture theatre at 287 Maria avenue. There were seventy-two petitioners for the theatre and eighteen against it. The opponents are more immediately interested in the property in the block where the theatre is to be placed.

Fred Zollman, well known as an attorney for the brewers of the state, appeared for the protestors, many of whom were present in person. Louis T. Herman led the opposition to the building of the theatre.

M. B. Hartmann, in pleading for the theatre, said that it will be an educational institution of distinct advantage to the neighborhood.

W. W. Henderson, contractor, has just finished an ornamental motion picture building at Military avenue and Yates street, Omaha. It is specially constructed for the purpose and has a seating capacity of 500. It will be opened in the near future. Just a block away, at Forty-second and Hamilton streets, the Delite theatre has closed. It was opened in a store building two years ago.

Louis J. Dittmar, manager of the Majestic theatre, has announced that a new motion picture house will be erected in the near future on Third street near Avery, a populous residential section of Louisville, Ky. Two sets of plans are being prepared by architects. One is for a theatre, the estimated cost of which is \$43,000 and the other for a combination theatre and apartment house to cost \$80,000. Mr. Dittmar says that a number of Louisville men will be associated with him in the enterprise. If a combination building is decided upon, the apartments will be for bachelors. The theatre will have a seating capacity of 1,100 and will be similar in appearance to the Majestic.

The Frisco Amusement Company (Heilbraun, Abraham & Rubin) have

Directory of New Theatres

purchased from Harry J. Woronow the plot, 50 x 150 feet, on the west side of Graham avenue, 125 feet north of Grand street, Brooklyn. The new owners have had plans filed by Architect Messinger for a motion picture theatre with two stores. The building is to have an open roof for summer performances, and is estimated to cost about \$28,000.

Work has been started on a new moving picture theatre to be erected by the Columbia Amusement Company in Erie, Pa. The theatre will be located in East avenue, between Seventh and Eighth streets. The managers of the company expect to have the new building opened about January 1.

Alterations and Improvements

The Theatorium, one of Denver's oldest and smallest downtown picture houses, has just reopened after a thorough remodeling which includes a new front, brilliant lighting display, inclined floors, increased capacity and a rechristening to the "Lyric." The house is now one of the coziest and most artistic small theatres in the West.

The Crescent Theatre, Syracuse, N. Y., closed recently to install a style K Wurlitzer Organ and Unit Orchestra and to remodel the front and interior of the house. It is said that the house will be one of the finest motion picture theatres in town when the changes are completed.

The Royal motion picture house, on South Broad street, near Front, Trenton, N. J., one of the chain of playhouses of the Charles Hildinger management, is being renovated and a new front is being constructed. Tile floorings are being laid and flats fitted up over the house, with entrance adjoining the theatre lobby.

The Star Theatre, at Clinton, Ill., has been reopened by David Mitchell, formerly of Farmer City, Ill. He has renamed it The Scenic and has made a number of improvements.

The old Halloran Theatre, at Moberly, Mo., which played both pictures and "legit" burned recently. The house will be rebuilt at once. Fred. C.

Use Films to Aid Nebraska Legislation

Sociological Subjects Shown on Screen with Gripping Realism Expected to Stir Up Public Opinion on Grave Questions

Special to MOTION PICTURE NEWS

Omaha, Neb., Nov. 3. THE showing of the Mutual film, "Dope," at the Empress theatre here just now promises to open up a new field for the influence of motion pictures in this State.

There has been considerable agitation for more strict laws in Nebraska regulating the sale of drugs. This agitation promises to culminate in action by the State Legislature during the session, which opens January 1.

Education of the public to better understand the situation and decided opinions one way or the other toward the traffic in "dope" is inevitable after the showing of the film here.

Strict laws regarding the attention of

feeble-minded children who may develop into murderous fiends at any time, will be taken up. There have been pictures shown here that probably gave rise to wider discussion and more intelligent opinions on that subject throughout the community.

The effect of quack medicines, the misuse of professional names and many other conditions that need remedying in this State furnish a demand for pictures to educate the public along lines the legislature will consider.

That pictures dealing with these Nebraska problems will enjoy a wide sale over the State and will command wide attention is obvious. And their influences for the betterment of conditions are manifold. GUY P. LEAVITT.

SALES AND LEASES

Leo Wertheimer, of Buffalo, owner of moving picture houses in that city, has leased the property at 918-24 State street, Erie, Pa., from the Selden estate for the purpose of erecting a photo-play house there, according to Boyd Hayes, real estate dealer. The property was leased for ten years at \$8,100 annually. The building to be constructed will cost \$50,000. According to Mr. Hayes, it is expected that the theatre will be opened next summer.

INCORPORATIONS

At Albany, N. Y.: AMERICAN & EUROPEAN FILM CO. \$10,000. J. L. Lyttle, G. L. Perocheau, W. H. Stetson, 43 Cedar street, New York.

At Trenton, N. J.: TOWACO LYCEUM CO. Motion pictures; \$10,000. Towaco. Frank L. Jacobs, Frederick Vandyne, David Young, Towaco.

BELMONT THEATRE COMPANY. Moving picture supplies; \$5,000. Newark. Adelbert Baier, South Orange; Frederick Conrad, Charles Schaetzle, Newark.

At Portland, Me.: THE RELIGIOUS & EDUCATIONAL MOTION PICTURE SOCIETY. To manufacture and deal in moving picture machines, films, cameras, etc.; \$1,000,000. Portland. President, A. F. Jones; treasurer, T. L. Croteau, Portland.

At Harrisburg, Pa.: THE BRYN MAWR AMUSEMENT COMPANY, Bryn Mawr, Pa.; to engage in the general amusement and motion picture business; capital \$10,000. Incorporators: James Lockwood, William A. Hayden and William Davis, all of Bryn Mawr.

Corbett and John Truitt, who owned the lease on the Moberly Theatre, now have leased the Orpheum, at Mexico, Mo., and will conduct it as a combination vaudeville and picture theatre.

Ben. D. Stafford has sold his theatre in Stillwater, Okla., and has moved to Arkansas City, Kan. It is probable he will secure a new location there.

NEW THEATRE IN LOUISVILLE

THE Alamo is the name of a new motion picture house being installed in the Wilkes Block, Fourth street near Walnut, Louisville, Ky. The new house was christened recently by the directors of the Fourth Avenue Amusement Company after a score of other names had been given consideration. The name "The Alamo" was selected as commemorative of the heroism of those Kentuckians who died with Crockett in the Alamo at San Antonio, Texas. The new house will be ready for its formal opening by November 1 at the latest. A seating capacity of 1,100 is assured. All chairs will have soft leather cushions. The interior of the theatre will be one of the most beautiful in the entire South.

Manufacturers of the Wonderful
Rembusch Patented Glass MIRROR SCREEN
and all other kinds of

Curtains for Moving Picture Projection

GLASS SCREENS	METALLIZED SCREENS
Mirror Screen	Gold Fibre
Mirror Screen Split	Silvercloth
Glass Transparent Screen for Rear Projection	Mirror Cloth
	Seamless, with stretchers
	White Opaque
Phone Seven-Eleven	F. J. REMBUSCH, Pres.

MIRROR SCREEN COMPANY

Incorporated

SHELBYVILLE, INDIANA

Mr. O. P. Sammons of Denison, Texas, bought a "Mirror Screen," and he writes that he cannot take care of the crowds. His picture is simply the talk of the community. A few second-hand screens for sale cheap.

Eastern Representative, Frank Manning, 125 W. 48th St., N. Y. Phone, Bryant 2416.

Music and the Picture

Editor's Note.—This department is prepared to answer all questions from exhibitors relating to the use of music in connection with photoplays, and to suggest suitable music for current pictures. Correspondence will be welcomed

Effective Playing for Comedies

TO imitate a violin or mandolin strike A and E together, or D and G together. For imitation of a calliope, street organ or music box, play some old piece, such as "Rainbow," "Want to Be in Dixie" in treble clef with both hands, accentuating left hand loud and jerky.

Thunder or heavy seas can also be used for short struggle scenes; bass clef, "right hand" F, A, flat, and C; sustain with loud pedal, a chromatic run with left hand. To break the monotony, if scenes are too long, play F sharp, A natural and C sharp (right hand) tremolo, F sharp octave or trill (left hand); crescendo, diminish, or both, according to picture.

For an absurd kiss, slap hands together quick. Don't do this unless it is a quick kiss, such as a man kissing a man or some other foolish situation. It can also be used when one party slaps another. This will get many a laugh if done at the right time.

For a fall, slide or anything on this order, make a glissando by running your third finger up the keys of the piano, or thumb down the keys.

The way I work this is when a party comes from the background to the center of the picture I come down from 8Va treble with thumb. When the party goes from center of picture to background I go up from bass clef to treble with the third finger; such as a horse, auto or like backing up. Gage this glissando by the action of the picture.

I have two sand blocks; one is stationary on a chair; the other I use with right hand for sneezes and so forth.

There are quite a few traps that a pianist can use, such as ratchet, whistle or auto horn; this must be worked with the foot on an old time auto horn.

Don't try to work any effects if you have to stop playing any longer than half a second or so; if not done at the right time it will spoil the picture. Now bear this in mind: I don't try any of the above mentioned effects unless the situations are ridiculous. It must be done at the right time and quickly.

Don't stop playing and wait for these certain parts, but work them and play, too, so to speak. Understand, I do not use the effects on all pictures; just occasionally. Where there are too many of these situations in a picture, like some of the Keystone comedies, don't work too often, as they become monotonous.

Some of these things can be used more often in the cities than in the smaller places. In the smaller town one has to play to the same people night after night;

one has to be careful and not do the same thing over and over again.

This applies to your music also. We all know there is quite a difference in playing pictures in the city from a town of say, 4,000 or 5,000.

In the smaller cities the pianist has to cater to the same patrons, while in a city one can use the same music quite a number of times before it gets tiresome to one in the audience. But where you have to entertain the same people week after week (and try to hold down the job by the year) you can not use the same music often, but have to have new material right along and lots of it.

This amounts to something. It is also very hard to find suitable music, unless one gets the best kind and it does not always fit the picture.

This grade of music is a little too ex-er-al run of the pictures.

I use only my better grade of music, such as the "Melody in F," "Fifth Nocturne," or "Fostis Goodbye" and the like, on only really good pictures, because you realize it isn't every picture that these pieces can be fitted to. According to some suggestions offered by the film producers, use such music for every little solemn scene in the picture.

The way I arrange this class of music is as follows: Never play such music unless I can finish playing at least half of it or more. If I can't do this, I wait until I get a scene long enough, so that I can play it. In this way I don't spoil a good piece of music by only playing just parts of it.

Here is another thing to take into consideration. In using some of the better music, or, in fact, any kind of music that is set to words. Take, for instance, the "Rosary," which nearly every one knows is very pretty, both words and music. There are a lot of people who know the words, and it would be out of place to play it for some scenes; say, for instance, where a soldier is dying or anything of this order.

While the music would suit such an occasion, the words would be out of place. We should try to connect the scenes as much as possible with the words. When "The Manger to the Cross" picture was exhibited at this house, some two years ago, I was asked and advised to play the "Holy City," but had to explain why this could not be used in any part of the picture.

The music was appropriate enough, but not the words, and you know it would be improper to play "Hosanna in Excelsis"

for any of the picture, except at the "Entrance into Jerusalem," and especially where the music suggestion sheet advised, which was "On the Way to Calvary."

Now, some will probably object to this, but this is my idea of playing the pictures. But if the proprietor wants the music played, do it that way.

In regard to popular music and its use in this line of work, it all depends upon how your employer wants you to use it. Some exhibitors want the popular hits played regardless of the pictures.

I use the popular music between shows, and also for the opening and closing, weeklies, educational, scenic and some comedies. That is where they fit the pictures. Not in the spirit of criticism, but as an illustration: In one of our nicest and most up-to-date picture palaces in the West, the orchestra played "Brass Band Ephram Jones," "By the Saskatchewan" (from the "Pink Lady") and "Punkinville Boys" for a comedy. Here is where my idea of playing the pictures would get a severe jolt.

To me it doesn't make any difference how popular a song is. I don't use it unless it can fit a picture or be played by some of the aforesaid rules.

I have a certain piece of instrumental music in my cabinet that I have only played three or four times; not popular, but semi-classic. When I can fit it to a picture it sounds 100 per cent. better than to just play it any time.

About old music (popular), it is well to have quite a number of pieces memorized; if not all of the melody just enough to let the audience get the drift of it.

One can use just the title of these popular songs or the first few lines of the chorus, as "He's a Devil" or "I'm the Guy" (just that much), to better advantage sometimes than the whole song.

I don't believe it is necessary to memorize all the late hits this way, but just the big hits, as there are a lot of people who don't know all the late popular music.

In playing in small towns it is sufficient to know what are the hits just in your own locality; not what is the rage in Chicago or New York, because some pieces are played out in these cities before they reach the small towns.

A pianist can play a song hit for a month or more in one of the smaller towns where there is no way of popularizing a song, and unless it is sung, he could never make it as popular as a singer could.

E. A. AHERN.

Music and the Picture

EDITOR'S NOTE.—This is the first article of a series to be run in "Accessory News," describing the leading musical instruments adaptable to the motion picture theatre.

Music for the Modern Photo-Playhouse

THE up-to-the-minute exhibitor has found that a successful house, in addition to its film service and first-class equipment, must offer music to its patrons to harmonize with the rest of the theatre.

The music question has been a problem to many exhibitors and various methods have been tried for pleasing the patrons.

The piano is the instrument most to be found in the smaller houses and while it is claimed, renders sufficient enjoyment, there can be no doubt that it is not adaptable to the modern house of ordinary seating capacity.

The orchestra of from three to seven pieces may be found in many houses, but almost every one concedes that it does not always harmonize as it should with the pictures.

This is because it is impossible for from three to five people to accurately follow the rapidly shifting theme of the action of a photoplay. The question of economy as well as the dependability of an orchestra practically places it in the same class as a piano for all picture purposes.

THE most reliable music for an up-to-the-minute exhibitor is a musical instrument of high tone and quality, combining all the effects of an orchestra, yet controlled by one person.

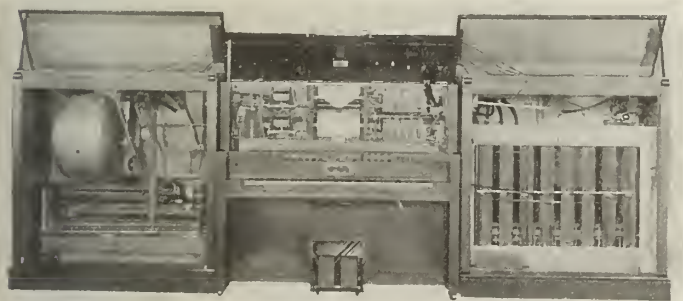

THE FOTOPAYER, OPEN, SHOWING DETAILS OF THE MECHANISM

This does not mean an automatic instrument that gives out tones of a hurdy-gurdy or mechanical grind, but an instrument containing the pure liquid notes of organ pipes, or the sweeter, mellow tones of a reed organ, as well as the violin, clarinet and flute pipes and other tones.

One of the well-known instruments of this type is the fotoplayer manufactured by The American Photoplayer Company, of Berkeley, Cal., and New York City.

The fotoplayer has been on the market for some four years, in which time it has been thoroughly tested and improved upon until now its distribution and popularity is established.

The instrument is offered in three different styles and sizes adaptable to the needs of different sized theatres.

THE fotoplayer is a beautiful product of fine material and workmanship and is built to withstand the gruelling strains of a motion picture theatre. The fotoplayer contains a player piano of high grade, a pressure reed organ and organ pipes of 65-note range.

In addition to this there are violin, cornet, cello, and flute pipes for orchestral effects.

The fotoplayer, of course, is equipped with orchestral bells, bass drum, pistol shot, cymbal, tom-tom, and all those traps and accessories that go to make up a successful orchestra, and allows the

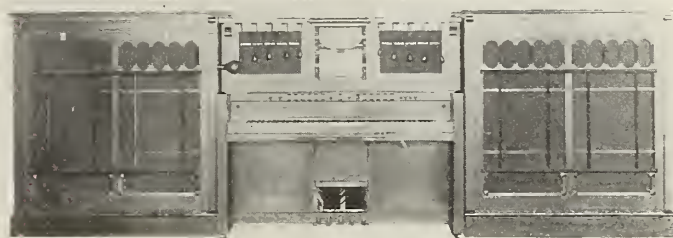

THE AMERICAN FOTOPAYER

operator at all times to follow every action of the picture from start to finish.

The fotoplayer is easily handled by one operator, rendering at all times music that harmonizes with the picture. It is a musical instrument, giving magnificent and beautiful orchestra and organ tones, and up to date as an example of technical instrumental construction.

One of its many features is the fact that it may be played by a musician of ordinary skill, who may thoroughly control the instrument by hand playing manually or by using the ordinary 88-note player piano music which can be purchased at any music shop at a nominal figure, giving a repertoire of many thousands of musical selections.

A UNIQUE feature of the fotoplayer is the so-called double-tracker device, which carries two rolls of music at one time as shown in the accompanying illustrations and by a simple turn of the lever the operator may change instantly from a light, snappy selection for comedies, to the music of tragedies or long photodramas.

An instrument of this type will ultimately be in general use in motion picture houses. It is built to fit the pit, can be installed on short notice and in the event of a sale of a theatre, may be removed without damage to instrument or theatre.

Many of the most beautiful theatres throughout the United States are now using the fotoplayer as well as some of the smaller houses in different parts of the country, where the exhibitor realizes that music of the right kind is essential to the successful theatre.

THE NEW BIG PICTURE DANCE BOOK

THE GEM DANCE FOLIO 1915

Containing 35 Complete Instrumental Pieces for the Pictures—A Great Big Book
SENT POSTPAID FOR 35 CENTS IN STAMPS OR MONEY ORDER

SHAPIRO, BERNSTEIN & CO.

224 W. 47th ST., NEW YORK

Make Your Lobby Display Attractive
There is nothing more fascinating to the public than a bright brass frame to display your photos or posters.

We make Lobby and Theatre Fixtures and Brass Rails of every description.

Don't fail to visit our Showrooms. Write for catalog.

THE NEWMAN MFG. CO.
171 Sycamore St. Cincinnati, Ohio
Branch Factories and Show Rooms: 101 Fourth Ave. New York, N. Y. 106-108 W. Lake St. Chicago, Ill.
Established 1882



THE CORCORAN RACK IS THE BEST EVER

Get No. 6 Price List

A. J. CORCORAN, Inc.

9 1/2 John Street New York

Novelty Slides

"True To Quality"
Write for Catalog N

Novelty Slide Co.

67 W. 23rd St. New York

What Do You Need?
CONSULT ACCESSORY NEWS

SAVE 35%

on your

CARBONS

Burn your stubs with a

CARBON Economizer



Pat. applied for.

Fits any lamp, gives perfect contact and conductivity, made of best material, screw does not come in contact with carbon, and will not weld to body of economizer; will burn upper or lower carbon to 3/4 of an inch.

NOW IN USE -784-NOW IN USE

"MECHANICALLY CORRECT"!!

Guaranteed to give satisfaction

\$1.25 Sizes \$2.00
Each. 1/2"-3/8"-3/4" Set—any sizes.

Sent postpaid upon receipt of New York Draft, Money Order or Cash.

THE CARBON ECONOMIZER CO.

757 W. Onondaga St., Syracuse, N. Y.

REMARKABLE LIGHTING EFFECTS FROM WINFIELD-KIRNER LAMP

Special to MOTION PICTURE NEWS

Los Angeles, Nov. 2.

THE last series of "The Trey o' Hearts" Universal serial, from the story by Louis Joseph Vance, which was to consist of two reels, has been increased to three, following a series of telegrams to exchange men in all parts of the country who approved of an additional reel.

The cause for the added footage is the remarkable success of a newly applied electric lamp which made it possible for Director Wilfred Lucas, of the producing company, to make very unusual interior scenes, and secure lighting effects heretofore impossible. The last three reels were made at Riverside, Cal., where all interiors were made at Mission Inn, perhaps the most elegantly furnished and finished hotel in Southern California. Success was obtained by this company after numerous other directors had signally failed.

The credit is rightfully given to Edward Winfield, engraver on a Los Angeles newspaper, who is inventor of the Winfield lamp used since 1907 by engravers in all parts of the world. But recently Mr. Winfield applied his invention to motion pictures, in the filming of "False Colors," by the Bosworth-Smalley company at the Majestic Theatre.

The scenes were very successful, as are also those of "The Trey o' Hearts" film. One particular effect secured was that of a lightning scene, showing the interior of a parlor at the inn. When the lightning flashes, trees and shrubbery thirty or forty feet from the building are shown in the film through the windows.

The lamps are portable, may be attached to any socket carrying 25 amperes, with 110 or 220 voltage, either direct or alternating current, and are being manufactured by the Winfield-Kirner Company of Los Angeles.

The first positive print was projected Saturday and the negative shipped to the New York factory. The picture was the talk of the Universal studio.

THIRD BLEACHMAN THEATRE IN BALTIMORE

Special to MOTION PICTURE NEWS

Baltimore, Nov. 3.

ANOTHER new downtown motion picture theatre will be built in Baltimore, Md. It will be strictly a motion picture house, and will be erected by Joseph Bleachman, who at present controls two picture houses in this city. The property is located at the northeast corner of Eutaw and Marion streets.

The new theatre will have a frontage of about 40 feet, with a depth of 150 feet; it will have a seating capacity of 300. The entire structure will contain the very latest word in ventilation, lighting and heating.

Work on the new structure is to be pushed to completion as soon as possible, and it is hoped that it will be ready for the opening shortly after the first of the year. Mr. Bleachman now controls the Picture Garden, 31 West Lexington street, and the Blue Mouse, 28 West Lexington street. Both of the latter houses are within five or six squares of his new venture.

Mr. Bleachman has only been in the motion picture business about one year, and is rapidly forging to the front as one of the big motion picture theatre owners in Baltimore and indeed in this entire state.

ONE NEW THEATRE A MONTH IN LOUISVILLE

Special to MOTION PICTURE NEWS

Louisville, Nov. 4.

THE Cherokee Theatre, Louisville's newest motion picture house, was opened to the public for the first time October 29. The Cherokee is a handsome structure located in the Highlands, one of the most aristocratic sections of the city.

The theatre is artistic in design with a seating capacity of about seven hundred. It is thoroughly modern, fireproof and perfectly appointed in every way for the comfort of its patrons. The heating, lighting and ventilating facilities, according to the management, are as perfect as scientific methods in this advanced age can make them.

The Cherokee will be devoted to the exhibition of motion pictures exclusively, and only high class films will be shown. The new theatre is the seventh motion picture house to be opened here in the last six months.

FURNITURE & FURNISHINGS

On RENTAL

We equip your settings complete in accordance with your scenario.

WILLIAM BIRNS

103-105 West 37th St.
Phone: Greeley 6255.

LANG'S FILM REELS

THE BEST MADE

14 in. \$1.50 10 in. \$1.00
CATALOGUE

LANG MFG. WORKS, Orleans, N. Y.

Kinematograph Weekly

\$5.15 a Year

The Leading Motion Picture Publication of Great Britain and Colonies

Sample Copies 10 cents

For Advertising Rates Write

Associated Moving Picture Press
250A Kingston Ave., Brooklyn, N. Y.

ROLL TICKETS

Specially Printed and Absolutely Guaranteed

Cash with order. No C. O. D. at these prices.
50,000 for \$5.40 200,000 for \$15.30
30,000 for 4.50 100,000 for 9.00

Write for Samples and Prices on Other Quantities.

Rees Ticket Co., 400 So. 10th St., Omaha, Neb.

THE
SIMPLEST
THE
BEST
BURNS 'EM SHORTEST

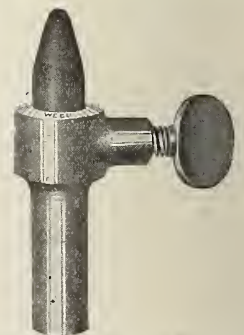

WEBB'S CARBON SAVER

Extra heavy and best material used throughout
Cut is one-half actual size

PRICE \$1.00 EACH PREPAID

Give size of carbons used when ordering.

MOTION PICTURE SPECIALTY & REPAIR CO.

326 3d Avenue, Pittsburgh, Pa.

THE ALBUQUERQUE FILM MFG. COMPANY, Inc.

Featuring that clever
Comedienne

Miss Dot Farley

Two Comedies Weekly

RELEASING THROUGH
The United Motion Picture Producers, Inc.
WHO DISTRIBUTE THROUGH
Warner's Features, Inc.

By request from many exchanges
we take pleasure in
reviving the

**FRONTIER
TWIN STORIES**

Written and made famous by Miss Dot
Farley. Under direction of
Gilbert P. Hamilton

Farce Comedy Production
BY

ARCHER McMACKIN

Nuf Sed

WESTERN STUDIO

406 Court St. Los Angeles, Calif.

GILBERT P. HAMILTON, Pres. and Gen. Mgr.

ELLA WHEELER WILCOX AND JACK ROSE ALLIED WITH WARNER'S FEATURES

THE poetess, Ella Wheeler Wilcox, has been attracted to the motion picture field. At the same time comes the announcement that Jack Rose has also become a convert to motion-pictures and will depict on the screen social conditions as he has seen them in the underworld. The output of these notable additions to the moving picture authorhood will be released by the United Film Service. (Warner's Features, Inc.) The first subjects are almost ready for the market.

After Rose organized the Humanology Film Producing Company, he approached Mrs. Wilcox with the object of adding her to his literary staff, and Mrs. Wilcox, appreciating the vast good to come from a filming of her master lyrical efforts, consented to the converting of her poems into pictures.

The organization of the Humanology Film Producing Company was effected at Boston recently, with Rose as president. W. W. Clarke, a former member of the Massachusetts Legislature, is the first vice-president, treasurer and attorney of the new corporation. D. W. Roberston, a pioneer in the motion picture industry in America, is second vice-president. E. V. Finch, for years on the staff of Colonel Goethals, is secretary. The company is capitalized at \$250,000 and has acquired five acres at Medford, Mass., where it has just completed a large studio building.

Rose has spent several weeks in New York with the object of contracting with a service firm for the marketing of his films.

RUMORS OF HUGE COMBINE FOLLOW SELZNICK'S FLYING TRIP

Special to MOTION PICTURE NEWS

Pittsburgh, Pa., Nov. 4.

THERE is something doing in the air and that air current is growing very strong. Just how far the deal has gone is impossible to state at this time but still there is something doing.

Louis J. Selznick, of the World Film Corporation was in Pittsburgh last week and hurriedly went to Chicago from this city. It is said he went there to confer with big interests regarding an amalgamation of some of the large feature film corporations of the country.

Mr. Selznick is also said to have taken a flying trip to St. Louis and then returned to New York for a conference with some of the big men in the film business.

NO CONNECTION BETWEEN THESE COMPANIES

IN an article in the October 10 issue of MOTION PICTURE NEWS, entitled "Manchester's \$10,000,000 Film Vision Vanishes," it was stated: "Two other concerns, the Topical News Company and the Daylight Screen Company, are lost in the shuffle.

On account of the prominence of Day and Night Screens, Inc., whose products are well known to the trade, a number of readers confused the name of this firm with that of the Daylight Screen Company. There is absolutely no connection between the two concerns and we trust this explanation will settle the matter.

??
??
??
??
??
??
??
??
??
??
??
??
??
??
??
**WHY DID
JUNE
RUN AWAY**

??
??
??
??
??
??
??
??
??
??
??
??
??
??
??
??
**WHO IS JUNE?
WHERE DID SHE RUN?**

ALCO

EVERY WEEK A FEATURE OF A PRETENTIOUS
NATURE FOR THOSE WHO WANT THAT KIND

ALCO

A CORPORATION MARKETING THE PRODUCT OF THE
ALL STAR FEATURE CORPORATION — CALIFORNIA
M. P. CORPORATION — POPULAR PLAYS AND PLAYERS
— B. A. ROLFE PHOTOPLAY CORPORATION

OFFICES OF THE ALCO FILM SERVICE

NEW YORK, 216 West 42d Street.—For State of
New York

CHICAGO, 512 Mallery Bldg., 5 So. Wabash Ave.
—For Illinois, Indiana

SAN FRANCISCO, 234 Eddy Street.—For Cali-
fornia, Nevada, Arizona.

BOSTON, 162 Tremont Street.—For Maine, New
Hampshire, Vermont, Rhode Island, Massachu-
setts, Connecticut.

PHILADELPHIA, 1331 Vine Street.—For South-
ern New Jersey, Eastern Pennsylvania

PITTSBURGH, 212 Fourth Avenue.—For West-
ern Pennsylvania, Ohio, Kentucky, West Vir-
ginia

BALTIMORE, 327 St. Paul Street.—For Dela-
ware, Maryland, District of Columbia, Virginia.

DENVER—For Colorado, Utah, Wyoming, and
New Mexico.

ST. LOUIS, New Grand Central Theatre, Grand
and Lucas Avenues.—For Missouri, Kansas,
Iowa, Nebraska.

NEW JERSEY, 71 W. 23d Street, New York.—For
Northern New Jersey.

MINNEAPOLIS, Temple Court Bldg.—For Wis-
consin, Minnesota, North and South Dakota

LOS ANGELES, 514 West 8th Street.—For Cali-
fornia, Nevada, Arizona.

DALLAS, 1902 Commerce Street.—For Texas,
Oklahoma, Arkansas.

SEATTLE, 1214 Third Avenue.—For Washing-
ton, Idaho, Montana, Oregon.

SPOKANE, 911 Trent Avenue.—For Washing-
ton, Idaho, Montana, Oregon.

BUTTE, 27 W. Park Street.—For Washington,
Idaho, Montana, Oregon.

PORTLAND, ORE., 710 Northwestern Bank Bldg.
—For Washington, Idaho, Montana, Oregon.

COMING — TWO EXCEPTIONALLY FINE PRODUCTIONS
NOV. 9 — THOMAS JEFFERSON IN RIP VAN WINKLE
NOV. 16 — DIGBY BELL IN THE EDUCATION OF MR. PIPP

HUGH HOFFMAN

ALCO

ALCO

AN EXTRAORDINARILY FINE PHOTOPLAY
PRODUCTION OF BRET HARTE'S LITERARY
GEM, TAKEN AT THE ORIGINAL LOCATIONS

SALOMY JANE

PRODUCED
BY THE
CALIFORNIA
M. P. CORP'N
By Arrangement with
The Liebier Co.



A MASTERPIECE OF CHARACTERIZA-
TION OF VIRILE WESTERN TYPES AS
BRET HARTE KNEW THEM - WITH
BEATRIZ MICHELENA AS "SALOMY"

ALCO FILM CORPORATION
HOME OFFICE, ALCO BUILDING, 218 WEST 42nd ST., NEW YORK

ALCO

Cosmofotofilm Co



London Film Co.
(Trade Mark)

"Where the Real Features Come From"

"For Home and Country"

A GREAT WAR SUBJECT FULL OF ACTION 2 PARTS
For Exclusive Rights, Address us at

World's Tower Bldg., 110 W. 40th St., New York

K. C. Marshals Exchanges Across Country

Offices Now Arranged in Boston, Philadelphia, Pittsburgh, Cleveland, Chicago, Atlanta, San Francisco, Denver, Seattle, Portland, Dallas and Los Angeles

THE K. C. Booking Co., Incorporated, has closed contracts with enough big independent exchanges to cover the entire country with its exclusive program, which now includes the releases of the Kinetophote Corporation and other features which have been obtained from independent producers.

In New England, the K. C. will book through the American Feature Film Co., of 162 Tremont street, Boston. The Eastern Booking Offices, with branches in Pittsburgh and Cleveland, will take the K. C. offerings in every instance. The Eastern head office at 1237 Vine street, Philadelphia, will book for Eastern Pennsylvania, Southern New Jersey, Virginia, Delaware, and the District of Columbia. The Pittsburgh branch of the Eastern company at 432 Wabash Building, will take care of Western Pennsylvania and West Virginia. The Eastern company's Cleveland branch is 218 Columbia Building and will handle the K. C. films for the entire state of Ohio. The K. C. is also opening a branch office in Chicago for Illinois and Wisconsin.

In the South, the Atlantic Service of Atlanta, Ga., will look after the K. C. interests in Georgia, Alabama, North Carolina, South Carolina and Florida.

The Far West and coast territory will be

covered by the service of the California Film Service Corporation with offices in San Francisco. This company will distribute in California, Oregon, Washington, New Mexico, Montana, Idaho, Wyoming, Colorado, Nevada, Arizona and Utah. The California Corporation has opened branches in Salt Lake City, Denver, Seattle, Portland, Ore., and Los Angeles.

As announced last week, the K. C. has signed contracts with the Dallas Film Co., of Dallas, Texas, to take over the booking of features for Texas, Louisiana, Oklahoma and Arkansas. For New York State and Northern New Jersey, the K. C. headquarters at 126 West Forty-sixth street will be the distributing center.

PANORAMA OF LEADING EVENTS IN GREAT WAR

A unique war film has been brought out by the Feature Films Company, Candler building, New York City. The producers have assembled scenes of the European conflict in a picture called "The War of the World" in panoramic form.

The purpose of the film is to present a complete pictorial view of the leading events, free from bias, from the assassina-

tion of Crown Prince Ferdinand of Austria to the battle of Luneville.

The picture is characterized by a sweeping breadth of action and a wide variety of scenes. There are four parts, divided into eighty-nine scenes, comprising every phase of the mammoth struggle.

The film will prove popular wherever shown. It will serve as a kind of pictorial chronology in aiding an audience to recall the fragmentary reports of the conflict appearing in the daily press.

In small towns particularly, where information concerning the events of the war has been scanty in comparison with the columns at the disposal of cosmopolitan readers, this visualization of the great war will meet with grateful acceptance.

No situation capable of picturesque and graphic treatment has been neglected in this motion picture record of the war.

The paper issued by the manufacturers is well adapted for effective display. It comprises six sheets showing troops charging a fortress, three sheets depicting dirigibles and aeroplanes dropping bombs on a cruiser; and one sheet containing portraits of the rulers of the warring countries.

Because the producers have prudently avoided anything that might excite racial and national prejudice it can be booked by exhibitors with the assurance that it will not offend any of their patrons.

WHY DID
JUNE
RUN AWAY

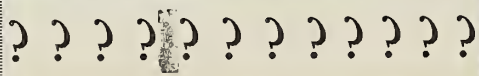

WHO IS JUNE?
WHERE DID SHE RUN?

WHY DID
JUNE
RUN AWAY

WHO IS JUNE?
WHERE DID SHE RUN?

EXPERIENCE TELLS THE STORY

IF YOU WANT TO KNOW ABOUT UNIVERSAL POSTERS ASK UNIVERSAL EXHIBITORS

Mr. Bryson of the Laemmle Film Service of Minneapolis says:

**"Universal Film Manufacturing Co.
New York City.**

Gentlemen:

It is very easy indeed to tell you what not only this office but our customers, the exhibitors in general and the public think of the Morgan Lithographs. They are par excellence. In fact we have never seen a single sheet of paper made by the Morgan people that has not been far superior to its nearest competitor. I do hope you are not thinking of making any change on Lithographs.

Respectfully yours,
The Laemmle Film Service,
J. W. Bryson"

And here is what an exhibitor, Otto Fees, of Parsons, Kansas, has to say in a letter to his Exchange.

" Dear Sir:

I am glad to say I think the grade of posters sent out by the Universal, compares very favorably with my competitors and is very superior to those sent out by the Mutual Film Corporation.

Yours with kind regards,
(Signed) Otto Fees, Parsons, Kansas."

Wonderful paper on the O'Rourke Stories. 3 one-sheets, 2 three-sheets and 2 six-sheets.

WHEN YOU WANT THE BEST POSTERS

WRITE TO

MORGAN LITHOGRAPH CO., Cleveland, Ohio

OR

SERVICE DEPARTMENT

UNIVERSAL FILM MANUFACTURING COMPANY

1600 Broadway

Carl Laemmle, Pres.

New York City



EDISON



WHAT COULD SHE DO?

A Drama By Gertrude Lyon

Sylvia Fairfax, a young graduate, upon the death of her father is brought face to face with the hitherto unthought of problem of earning a livelihood. Brought up in affluence she is bewildered by the sudden change of circumstances. She answers an advertisement for a governess and secures such a position in a well to do family only to discover soon, that she is utterly unable to control the children of the family. She is discharged and seeks the city, bag in hand. Her varied experiences in the ordinary boarding house, then in a Department Store lead to a thrilling climax in the Police Inspector's office. She is at last acquitted of theft and engaged as a detective on the police force. Her first case—one of kidnapping—proves what she could do, for she outwits the kidnappers and wins back the stolen child. A thrilling reel.

In three parts. 3,000 feet. To be released Friday, Nov. 20th

COMING EDISON RELEASES

Mon.	Nov. 23—His Chorus Girl Wife.....	Drama	1000 ft.
Tues.	" 24—A Gypsy Madcap.....	Drama	1000 "
Wed.	" 25—The Temple of Moloch.....	Drama	1000 "
Fri.	" 27—The King's Move in the City, in two parts.....	Drama	2000 "
Sat.	" 28—The Last of the Hargroves.....	Drama	1000 "
Mon.	" 30—Wood B. Wedd Goes Snipe Hunting.....	Comedy	1000 "

Order Edison Posters of the Morgan Lithograph Co., Cleveland, Ohio, direct



TRADE MARK
Thomas A Edison
Makers of the Edison Kinetoscope,
Model "D"

THOMAS A. EDISON, Inc.
275 Lakeside Avenue, Orange, N. J.



NOVEMBER 21, 1914

Motion Picture News

HAS THE QUALITY CIRCULATION OF THE TRADE

PARAMOUNT PICTURES

JESSE L. LASKY

PRESENTS

THE PROMINENT DRAMATIC ACTOR

CHARLES RICHMAN

IN THE MOST SUCCESSFUL AMERICAN PLAY

**THE MAN
FROM HOME**

By BOOTH TARKINGTON AND HARRY LEON WILSON

By ARRANGEMENT WITH THE LEIBLER CO. NOW PLAYING

JESSE L. LASKY FEATURE PLAY CO.

LONG ACRE THEATRE W. 48TH STREET N.Y.C.

JESSE L. LASKY PRESIDENT SAMUEL GOLDFISH TREAS. & GENL. MANAGER CECIL B. DeMILLE DIRECTOR GENERAL



ROBERT LEONARD AND ELLA HALL
IN

THE MASTER KEY

by JOHN FLEMING WILSON

*A Thrilling Story of
Mystery and Romance!*

FIFTEEN WEEKS
MOVING PICTURES
THIRTY REELS

UNIVERSAL

SPECIAL FEATURES
UNIVERSAL
EPILOGUE



DANIEL FROHMAN
Presents

TYRONE POWER

In the famous society drama,

ARISTOCRACY

By
Bronson Howard,



A pictorial-
dramatic study of
society and its
shams,

In Four Parts
of
Motion Pictures,

Released Nov. 16th.

Produced by the

FAMOUS PLAYERS FILM CO

ADOLPH ZUKOR, President,
DANIEL FROHMAN, Managing Director EDWIN S. PORTER, Technical Director
Executive Offices,
213-229 W. 26TH STREET, NEW YORK.



A PROVED \$ SUCCESS



The Wrath of the Gods

Get Your \$ Share!

THE WRATH OF THE GODS

Six smashing, thrilling reels of concentrated drama produced by
THOS. H. INCE

Japanese Story, Japanese Actors, Volcano in Eruption!

Filling theatres. It fattens your box office—book it now

Griffith Produced

THE BATTLE OF THE SEXES

in five reels. The vital material would have made eight but that isn't Griffith's way. Greatest story of the Double Standard ever produced or written. It jams theatres. **BOOK IT!**

A Sensational Feat That Will Set Your [Whole Neighborhood Talking Is the Climax of

THE GREAT LEAP

MAE MARSH and **ROBERT HARRON** are the stars; four reels is the length and intense drama wonderfully well presented is the big claim to your attention.

HOME SWEET HOME

THE GREAT GRIFFITH MASTERPIECE IN SIX REELS OF HEART APPEAL, TENSE INTEREST, VITAL ACTION AND GORGEOUS INVESTITURE. WHEN "HOME SWEET HOME" BOOKS IT RE-BOOKS BECAUSE OF POPULAR DEMAND. THIS IS THE PRIME SEASON FOR REALIZING ON THE PROFIT OPPORTUNITY.

CONTINENTAL FEATURE FILM CORP.

29 Union Square, New York

A L L M U T U A L E X C H A N G E S

HOUSE FILLING FEATURES

In Wartime, Warlike Features Bring the Business

Here are three assured popular successes



MEXICAN WAR PICTURES

By Special Contract with General Villa

THE DISHONORED MEDAL

With French troops in action



BATTLE OF GETTYSBURG

Greatest War Feature Ever Produced

THE MOUNTAIN RAT 4 Reels

A tense vital drama of Western Life

GANGSTERS 4 Reels

Great run at Weber's Theatre, New York. "A great lesson for all."—New York American

RUY BLAS

with William Garwood and
Francelia Billington

THE FLOOR ABOVE

the great Oppenheim mystery
story

FROU FROU

with Maude Fealy, after Au-
gustine Daly's Production

SAPHO

with Florence Roberts

MOTHS

from Ouida's great novel, a
Thanouser Big Production

DOPE

with Laura Nelson Hall

CARDINAL RICH- ELIEU'S WARD

Florence La Badie and James
Cruze

ZU ZU

the BAND LEADER, a two-
reel Keystone, with
Mabel Normand

JOSEPH IN THE LAND OF EGYPT

James Cruze as Joseph, Mar-
guerite Snow as Potiphar's wife

LEGEND OF PRO- VENCE

James Cruze and Maude Fealy

CONTINENTAL FEATURE FILM CORP.

29 Union Square, New York

A L L M U T U A L E X C H A N G E S

THE PHOTOPLAY SENSATION OF 1914
 PACKS THE BIGGEST THEATRE

LIFE'S SHOP WINDOW

BY VICTORIA CROSS



28,000 PAID ADMISSIONS IN 4 DAYS AT THE
 ACADEMY OF MUSIC NEW YORK CITY
 PRODUCTION MADE AT WILLIAM FOX STUDIOS.

Call, Wire or Write

THE BOX OFFICE ATTRACTION CO.

WILLIAM FOX, President

Executive Offices, 130 West 46th Street, NEW YORK

Phone Bryant 7340

NEW YORK, 130 West 46th St. Phone Bryant 7340.
 WASHINGTON, D. C., 434 Ninth St., N. W. Phone
 1426 Main.

CHICAGO, Mallers Bldg. Phone Central 1716.
 CLEVELAND, Columbus Bldg. Phones Main 5677;
 Central 6260 R.

PHILADELPHIA, 1333 Vine St. Phone Walnut 4503-4.
 DALLAS, 1907 Commerce St. Phone South Western
 Main 2066

MINNEAPOLIS, Jewelers Exchange Bldg. Phone
 Northwestern Nicollet 2498.

ST. LOUIS, 3632 Olive St. Phones Bell-Tindell 795;
 Kinloch, Delmar 4363.

SAN FRANCISCO, 107 Golden Gate Ave. Phone Mar-
 ket 4880.

PITTSBURGH, 121 Fourth Ave. Phone Court 1302.
 SYRACUSE, Eckel Theatre Bldg. Phone Warren 119.

BOSTON, 10-12 Piedmont St. Phone Oxford 6254.
 KANSAS CITY, 928 Main St. Phones Bell, Main 1008;
 Home Main 7253.

DENVER, Ideal Bldg. Phone Main 5071.

SEATTLE, 121 1/2 Third Ave. Phone Elliott 1039.

Miss Ivy Close, voted the most beautiful woman in England, in
"LOST IN LONDON"



From riches to poverty and back again. Flower girl, artist's model, pre-

-mier danseuse - then the big climax. A great romantic drama in three parts.

UNITED FILM SERVICE (WARNER'S FEATURES, INC.) N.Y.

NOW READY FOR BOOKING

D'Annunzio's

“CABIRIA”

THE WORLD'S MASTER SPECTACLE

**11 Stupendous
Parts**

**1000 Imposing
Scenes**

**5000 People in
the Cast**

UNIVERSALLY ACCLAIMED THE GREATEST ENTERTAINMENT EVER GIVEN TO THE PUBLIC

Can be presented at one performance
or in series to suit local conditions

DISTRIBUTING OFFICES NOW BEING ESTABLISHED

<p>CALIFORNIA SOL. LESSER 234 EDDY ST., 'FRISCO</p>	<p>E. PA., MD., DEL., D. C. HARRY BRYAN PHILADELPHIA</p>	<p>ILLINOIS FRANK SAMUELS CHICAGO</p>
<p>NEW ENGLAND W. E. GREENE 126 TREMONT ST., BOSTON</p>	<p>TEXAS, OKLA., ARK. FRANCIS GILBERT DALLAS</p>	<p>LA. and MISS. HERMAN FITCHENBERG Plaza Theatre, NEW ORLEANS</p>
<p>NEW YORK and NEW JERSEY WERBA & LUESCHER New York Theatre, NEW YORK CITY</p>		

Others in preparation for announcement later

PROPOSITIONS WILL BE CONSIDERED
IN ORDER OF RECEIPT

Address HARRY R. RAVER, Director General

ITALA FILM CO. of AMERICA
220 West 42nd Street New York City

LOIS WEBER & PHILLIPS SMALLEY

IN ASSOCIATION WITH **BOSWORTH** INC. LOS ANGELES, CALIFORNIA



SIEGE of PARIS

MOTHER'S SALON

BOYHOOD DAYS WITH PRINCE GEORGE (PRESENT KING) OF ENGLAND

IN SIR HENRY IRVING'S DRESSING ROOM

DIRECTOR OF BOSWORTH INC.



CONCERT PIANIST AT 16

CHURCH ARMY WORKER IN THE SLUMS

LEADING ROLE IN 'WHY GIRLS LEAVE HOME'

MARRIAGE TO PHILLIPS SMALLEY

AUTHOR & DIRECTOR OF MOST FAMOUS PLAY EVER SCREENED 'HYPOCRITES'



The ALCO of FAVORITE



ALCO IS A SHORT NAME FOR A SELECT COTERIE OF THE BEST AMERICAN MOTION PICTURE PRODUCING COMPANIES. NATURALLY THEIR OBJECT IS TO MAKE MONEY, BUT BACK OF ALL THAT IS A PRIDE IN THEIR OUTPUT THAT TAKES PRECEDENCE OVER PROFIT. THEY ARE PEOPLE WHO FIND A JOY IN GIVING VALUE RECEIVED





GARDEN

AMERICAN STARS

ALCO IS A BIG CONCERN
 COMPOSED OF THE BEST
 OF PROCURABLE PEOPLE

A GLANCE AT OUR LITTLE ROSE
 GARDEN WILL SHOW THE KIND
 OF TALENT THAT ALCO EMPLOYS

ALCO PRODUCING COMPANIES
 THE ALL-STAR FEATURE CORP'N
 CALIFORNIA M. P. CORPORATION
 POPULAR PLAYS AND PLAYERS
 LIFE PHOTO FILM CORPORATION
 THE B. A. ROLFE PHOTOPLAYS, INC.

ALCO FILM SERVICE OFFICES
 NEW YORK, CHICAGO, SAN FRANCISCO
 PHILADELPHIA, PITTSBURGH, BALTIMORE
 MINNEAPOLIS, KANSAS CITY, PORTLAND
 SPOKANE, SEATTLE, LOS ANGELES, DALLAS
 DENVER, ST. LOUIS, BOSTON, DETROIT. BUTTE



ALCO FILM CORP'N

HOME OFFICE: ALCO BLDG., 218 WEST 42d STREET, NEW YORK



HUGH HOFFMAN

THE ALCO FILM CORPORATION PRESENTS

LITTLE LORD FAUNTLEROY



FAUNTLEROY AND HIS
FRIENDS AT MR. HOBBS'
GROCERY STORE.

RELEASED NOVEMBER 16
FRANCES HODGSON BURNETT'S SWEET
STORY OF CHILDHOOD HAS LENT
ITSELF WELL TO MOTION PICTURES.
ADMIRABLY ADAPTED AND PRODUCED
IT WILL WITHOUT DOUBT PROVE
THE SEASON'S JUVENILE SENSATION

NOV. 23 DIGBY BELL, IN THE ALL STAR COMEDY
THE EDUCATION OF MR. PIPP
NOV. 30 BEATRIZ MICHELENA AS LOVEY MARY IN
MRS. WIGGS OF THE CABBAGE PATCH
PRODUCED BY THE CALIFORNIA M. P. CORPORATION

ALCO FILM CORP'N
ALCO BLDG., 218 W. 42nd ST., NEW YORK

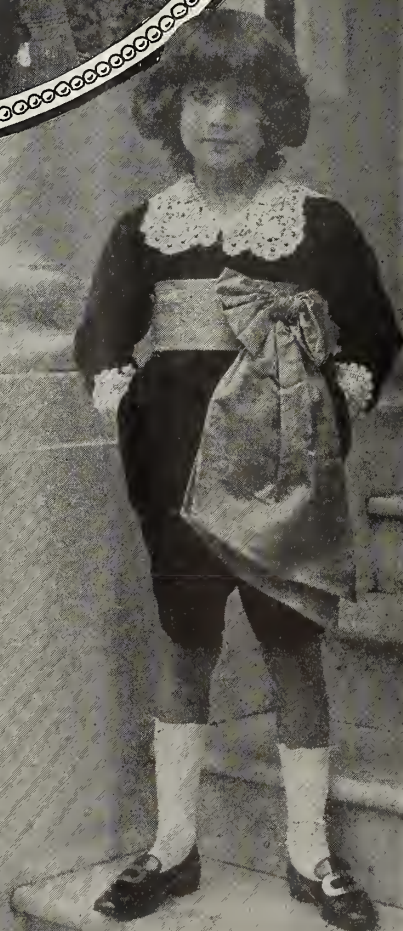

HUGH HOFFMAN

THE MILLION DOLLAR MYSTERY

Story by Harold MacGrath
Scenario by Lloyd Lonergan

Thanhouser's Million Dollar
Motion Picture Production

22 Episodes
of this
Stupendous
Motion Picture
Have Been
Released

and the exhibitors
say — "It's the greatest
box office attraction ever
brought out!" The Million Dollar
Mystery can be obtained regardless
of the regular program being used.
For booking arrangements apply to

Syndicate Film Corporation

71 West 23rd Street, New York

Room 411, 5 S. Wabash Avenue, Chicago

or Syndicate Film Corporation Representative at any
Mutual Exchange in the United States and Canada

Thanhouser's
All Star
Productions
Meet With the
Approval of

—*Everybody*
—*Everywhere*
—*Everytime*

The Thanhouser
Three-A-Week

Tuesday, Nov. 17th. "The Pawns of Fate"—(two reels) a powerful drama portraying the political life of a governor whose kindness toward an old chief clerk enables him to sustain his duty to the state. Enacted by an all-star cast including Morgan Jones, Virginia Waite, Madeline and Marion Fairbanks, Arthur Bauer, Marguerite Loveridge, Frank Wood, Ethel Jewett and David Thompson.

Sunday, Nov. 22nd. "A Messenger of Gladness"—an interesting adventure of a child who brought good into the lives of several people on Thanksgiving Day. The cast includes Helen Badgley, Gordon Harris, Ethyle Cooke, Rennie Farrington, Nolan Gane, Minnie Berlin, N. S. Woods, Arthur Bauer and many others.

**Thanhouser Film
Corporation**

New Rochelle, N. Y.

Head European Office, Thanhouser Films. Ltd.
London, W. C., England



Julius Caesar

Master of spectacles, the mightiest of a long line headed by "Quo Vadis?"

"Julius Caesar" is an epoch. Beside it, all of filmdom's great creations shrink by comparison. We, who launched "Quo Vadis?", "Antony and Cleopatra" and "The Last Days of Pompeii", find no existing standard by which to gauge "Caesar."

Yet it is only six reels in length requiring, at normal speed, but one hour and a half to project.

Into this ninety minutes of entertainment have gone eighteen months of steady labor, the services of twenty thousand people, and a sum of money representing several fair sized fortunes.

"Julius Caesar" will be ready for booking through the following Kleine offices, November 15th:

Chicago
166 N. State St.

Boston
597 Washington St.

Minneapolis
210 Temple Court Bldg.

Toronto
56 King St., W.

New York
226 W. 42nd St.

Dallas
238 Saner Bldg.

Pittsburgh
509 Lyceum Theatre

Los Angeles
701 Majestic Theatre

Atlanta
43 Moore Bldg.

Denver
405 Railroad Bldg.

Seattle
213 Orpheum Theatre

San Francisco
653 Pacific Bldg.

GEORGE KLEINE

LUBIN

THE PERFECTION OF PHOTO-MOTION
EVERY EXHIBITOR SHOULD BOOK THESE WONDERFUL PICTURES

(Through the General Film Special Service)

By Arrangement with Fred Mace

EVELYN NESBIT THAW
 and her son, **RUSSELL WILLIAM THAW**, in
"THREADS OF DESTINY"

5 Reel Drama By Wm. H. Clifford Direction—Joseph W. Smiley

"STONEWALL JACKSON'S WAY"

3 Reel Drama By Emmett Campbell Hall Direction—Edgar Jones

READY FOR EARLY RELEASE

RAYMOND HITCHCOCK

IN **"THE RINGTAILED RHINOCEROS"**

5 Reel Comedy Drama By Lawrence McCloskey
 Direction—George W. Terwilliger

ROSE COGLAN

And **ETHEL CLAYTON** in

"THE SPORTING DUCHESS"

7 Reel Comedy Drama By Cecil Raleigh Direction—Barry O'Neil

3 Reel Drama **"THE SPY'S FATE"** Direction—Joseph W. Smiley
 By W. H. Lippert

IN PREPARATION

"THE COLLEGE WIDOW"

Featuring **ETHEL CLAYTON** and **GEORGE SOULE SPENCER**
 5 Reel Comedy By George Ade Direction—Barry O'Neil

READY FOR EARLY RELEASE

EDWIN ARDEN

8 Reel Drama By Edwin Arden IN **"EAGLE'S NEST"** Direction—Romaine Fielding

SIX REGULAR RELEASES EACH WEEK

"THE BELOVED ADVENTURER," Tenth of Series, "Lord Cecil Keeps His word"	Drama....Monday,	November 16th
"SHE WAS THE OTHER"	} Split Reel Comedies.....Tuesday,	November 17th
"CHEAP TRANSPORTATION"		November 18th
"THE MARRIAGE WAGER"—Two Reel Drama.....	Wednesday,	November 19th
"ON SUSPICION"—Two Reel Drama.....	Thursday,	November 20th
"THE UNKNOWN COUNTRY"—Drama.....	Friday,	November 21st
"THE TALE OF A COAT"	} Split Reel Comedies.....Saturday,	
"THE DADDY OF THEM ALL"		

SPECIAL ONE, THREE AND SIX SHEET POSTERS.

Lubin Manufacturing Company, Philadelphia, Pa.

Chicago Office:
 154 West Lake Street



VITAGRAPHS

LIFE PORTRAYALS VITA-LAUGHS

"THE LEVEL"—Drama **MONDAY, NOV. 23rd**

His kindly treatment and consideration of his wife is misinterpreted as weakness. He assumes a brutal attitude and quickly she pleads for his love. She learns a lesson to the joy of both. An all star cast.

"THE OLD FLUTE PLAYER"—
 Drama in Two Parts—**TUESDAY, NOV. 24th**

By those better off he is patronized. When he is restored to the dignity of Count, he is courted by those who snubbed him. His daughter is sought by her employer as her daughter-in-law. CHARLES KENT and EDITH STOREY are the principals.

"NETTY OR LETTY"—Comedy **WEDNESDAY, NOV. 25th**

It's no easy matter to tell one from the other. Many laughable and confusing mistakes occur. They are twins and that sets everything right. DOROTHY KELLY, GEORGE COOPER, LILLIAN BURNS and JAMES MORRISON are the cast.

"CAUSE FOR THANKSGIVING"—Comedy **THURSDAY, NOV. 26th**

"Sonny Jim" trades the family turkey for a colored baby. Daddy Jim wants the turkey and Mammy wants her baby. When both are returned its a big Thanksgiving Day. BOBBY CONNELLY as Sonny Jim.

"THE CURING OF MYRA MAY"—Comedy **FRIDAY, NOV. 27th**

She poses as a young lady. She wins a young man's love. He learns she is only a school girl and she is glad to get back in short dresses. NORMA TALMADGE and DONALD HALL are the leads.

"CONVICT, COSTUMES AND CONFUSION"—
 Comedy in Two Parts—**SATURDAY, NOV. 28th**

Jones goes to the masquerade dressed like the devil. He changes his suit for a convict's and then the fun begins. It doesn't end until the convict is caught and Mrs. Jones gets her clothes back. BILLY QUIRK, LEE BEGGS and RICA ALLEN are the fun makers.

SIX A WEEK

"EVERYTHING AGAINST HIM"—Drama.....Monday, Nov. 30	"THE MAN THAT MIGHT HAVE BEEN"—Drama.....Thursday, Dec. 3
"SAVED FROM A LIFE OF CRIME"—Two-Part Drama..Tuesday, Dec. 1	"THE METHODS OF MARGARET"—Comedy.....Friday, Dec. 4
"THE MYSTERIOUS MR. DAVEY"—Comedy.....Wednesday, Dec. 2	"BUNNY'S LITTLE BROTHER"—Two-Part Comedy.....Saturday, Dec. 5

VITAGRAPH ONE, THREE AND SIX SHEET POSTERS

THE VITAGRAPH COMPANY OF AMERICA, E. 15th St. and Locust Ave., Brooklyn, N. Y.

BROADWAY STAR FEATURES

RELEASED

A MILLION BID	5 PARTS
GOODNESS GRACIOUS	3 PARTS
MR. BARNES OF NEW YORK	6 PARTS
LOVE, LUCK AND GASOLENE	3 PARTS
CAPTAIN ALVAREZ	6 PARTS
SHADOWS OF THE PAST	3 PARTS
BINGLES' MELODRAMA	3 PARTS
MY OFFICIAL WIFE	5 PARTS
UNCLE BILL	3 PARTS
THE PAINTED WORLD	3 PARTS
FLORIDA ENCHANTMENT	5 PARTS
413	3 PARTS
THE WIN(K)SOME WIDOW	4 PARTS

PRODUCED BY THE

VITAGRAPH COMPANY
 OF AMERICA

AS PRESENTED AT THE

VITAGRAPH THEATRE
 NEW YORK CITY

FOR TERMS AND PARTICULARS APPLY

GENERAL FILM CO.'S
 SPECIAL SERVICE

By Arrangement with Broadway Star
 Feature Co. (Inc.)

COMING

4-Part War Drama	THE TANGLE
3-Part Fire Prevention Romance	THE LOCKED DOOR
4-Part Psychic Drama	SYLVIA GRAY
5-Part Drama from the Book	THE LITTLE ANGEL OF CANYON CREEK
3-Part Drama of Life	TWO WOMEN



EDISON



THE KING'S MOVE IN THE CITY

Being an Adventure of Lord Stranleigh

By Robert Barr

Lord Stranleigh's meeting with Lady Sinclair brought the young nobleman out of the atmosphere of boredom which had surrounded him for a long time, and he soon found that life was really worth living after all. His proposal to her was met, however, with a declaration on the young lady's part that until he should prove himself really worthy by accomplishing some real good in life, she could not entertain his suit. On his way home from a reception his first opportunity occurred as they passed a house on fire. But his bravery didn't satisfy her. Later on, possessed of an enormous fortune, he heard of the McKellers who had been caught in a mining scheme and were about to be swindled out of their investment. The McKellers were in despair when young John Hazel happened to drop into the office. On learning the facts in the case, Hazel insisted upon giving Peter a card of introduction to Lord Stranleigh. Peter called upon the young nobleman and explained the whole affair. Stranleigh at once decided upon a scheme. Accompanying Peter to his father's office, he told him to give orders to twenty brokers to buy in a certain amount of stock when offered, and in this manner, not only was the scheming group defeated, but the market value of the property was greatly enhanced.

In two parts. 2,000 feet. To be released Friday, Nov. 27th

COMING EDISON RELEASES

Mon.	Nov. 23	His Chorus Girl Wife.....	Drama	1000 ft.
Tues.	" 24	A Gypsy Madcap.....	Drama	1000 "
Wed.	" 25	The Temple of Moloch.....	Drama	1000 "
Fri.	" 27	The King's Move in the City, in two parts.....	Drama	2000 "
Sat.	" 28	The Last of the Hargroves.....	Drama	1000 "
Mon.	" 30	Wood B. Wedd Goes Snipe Hunting.....	Comedy	1000 "

Order Edison Posters of the Morgan Lithograph Co., Cleveland, Ohio, Direct



TRADE MARK
Thomas A Edison
 Make-up of the Edison Kinetoscope,
 Model "D"

THOMAS A. EDISON, Inc.
 275 Lakeside Avenue, Orange, N. J.





HAVE YOU NOTICED ?



For the past few weeks we have been devoting our time and energies to completing final arrangements for the launching of

KRITERION PROGRAM

Now that the most important part of this work is finished, we are in a position to name our various brands and the style of their releases, viz.:

PARAGON, one reel per week, Comedy
 THISTLE, one reel per week, Drama
 MONARCH, one reel per week, Drama
 NAVAJO, one reel per week, Drama
 SANTA BARBA, two reels per week, Comedy and Drama
 ALHAMBRA, two reels per week, Comedy and Drama

Our next announcement will acquaint you with the stars who will characterize the leading roles for these companies. It will surprise you, for they are all WELL KNOWN and FAVORITE PLAYERS, who have interested and pleased countless audiences during past performances, and will continue to demonstrate their ability in our "ALL MADE IN AMERICA PROGRAM."

For further information communicate with our exchanges in the following cities:

Baltimore, Dallas, Atlanta, Denver, Seattle, San Francisco, Los Angeles, Milwaukee, Toronto, Montreal, Kansas City, Minneapolis, Chicago, Indiana, St. Louis, Cleveland, Pittsburg, Buffalo and Boston, or better yet, get in touch with

MICA FILM CORPORATION
 220 West 42nd Street (*temporary*) New York City
(headquarters)

Exhibitors:

Following is the list of exchanges
NOW booking



—Thanhouser's Greatest Photoplay. Episode
No. 1 of this new serial will be released Nov.
23rd. Book NOW!

TOWN.	NAME OF CO.	ADDRESS.	REPRESENTATIVE.
Amarillo, Texas	M. F. C. of Texas	304 E. 4th St.	L. M. Cobb.
Atlanta, Ga.	Mut. Film Corp.	Mion Bldg., Luckie St.	A. C. Bromberg.
Baltimore, Md.	Mut. Film Corp.	28 W. Lexington St.	C. G. Powell.
Boston, Mass.	M. F. C. of Mass.	1106 Boylston St.	H. Hirsch.
Buffalo, N. Y.	Mut. Film Corp.	272 Washington St.	Earl B. Shaw.
Butte, Mont.	Pacific M. F. Co.	American Th. Bldg.	W. A. Coughlin.
Charlotte, N. C.	Mut. Film Corp.	322 N. Tryon St.	C. S. Manning.
Chicago, Ill.	M. F. C. of Ill.	5 S. Wabash Ave.	R. C. Seery.
Cincinnati, O.	Mut. Film Co.	111 E. 7th St.	Floyd Lewis.
Cleveland, O.	Mut. Film Co.	166 Prospect Ave. S. E.	A. P. Desormeaux.
Columbus, O.	Mut. Film Co.	422 N. High St.	Nate LeVene.
Dallas, Texas	M. F. C. of Texas	1807 Main St.	L. B. Remy.
Denver, Colo.	Colo. M. F. Corp.	Box 536	H. Lustig.
Des Moines, Ia.	M. F. C. of Ia.	Cohen Bldg.	S. J. Berman.
Detroit, Mich.	Mut. Film Corp.	97 Woodward Ave.	R. K. Shallenberger.
El Paso, Texas	M. F. C. of Texas	524 Trust Bldg.	S. D. Cobbs.
Evansville, Ind.	M. F. C. of Ind.	Keene Bldg.	C. B. Alves.
Grand Rapids, Mich.	Mut. Film Corp.	7-8 Hawkins Bldg.	Jack Kulms.
Harrisburg, Pa.	M. F. C. of Pa.	9 N. 4th St.	Geo. Hallett.
Indianapolis, Ind.	M. F. C. of Ind.	150 N. Illinois St.	J. G. Conner.
Kansas City, Mo.	M. F. C. of Mo.	928 Main St.	S. J. Berman.
Los Angeles, Cal.	Pacific M. F. C.	738 S. Olive St.	Ben S. Cohen.
Memphis, Tenn.	Mut. Film Corp.	McCall Bldg.	M. W. Lawrence.
Milwaukee, Wis.	West. Film Exch. of Mil. waukee	301 Enterprise Bldg.	M. Annenberg.
Minneapolis, Minn.	Mut. Film Corp.	22 N. 6th St.	M. F. Judell.
New Orleans, La.	Mut. Film Corp.	340 Carondelet St.	M. W. Lawrence.
New York City	Mut. Film Corp.	71 West 23d St.	Alfred Weiss.
New York City	West. Film Exch.	145 W. 45th St.	H. C. Hancock.
Oklahoma City, Okla.	M. F. C. of Okla.	25 Hudson St.	A. G. Hull.
Omaha, Neb.	M. F. C. of Neb.	1413 Harney St.	C. B. Price.
Philadelphia, Pa.	M. F. Exch. of Pa.	902 Filbert St.	P. F. Glenn.
Pittsburgh, Pa.	Cont. Feat. Film Corp.	420 Penn Ave.	S. E. Abel.
Portland, Ore.	Pacific M. F. C.	389 Oak St.	W. T. Binford.
Portland, Me.	Mut. Film Corp.	Fidelity Bldg.	S. W. Hatch.
Salt Lake City, Utah	M. F. C. of Utah	123 E. 2d South.	Wm. P. Moran.
San Francisco, Cal.	Pacific M. F. C.	162 Turk St.	Ben S. Cohen.
St. Louis, Mo.	M. F. C. of Mo.	1311 Pine St.	C. N. Sutton.
Seattle, Wash.	Pacific M. F. C.	205 Joshua Green.	H. K. Brin.
Sioux Falls, S. D.	Mut. Film Corp.	209 W. 9th St.	E. C. Nehis.
Spokane, Wash.	Pacific M. F. C.	408 First Ave.	J. E. Madsen.
Springfield, Mass.	M. F. C. of Mass.	179 Dwight Ave.	Wm. Hart.
Syracuse, N. Y.	West. Film Exch.	Weiting Bldg.	E. M. Blackman.
Tampa, Fla.	Mut. Film Corp.	405 Curry Bldg.	E. F. Tarbell.
Washington, D. C.	Mut. Film Corp.	428 9th St. N. W.	C. G. Powell.
Wheeling, W. Va.	Mut. Film Corp.	4-5 Register Bldg.	Lee Cox.
Wilkes Barre, Pa.	M. F. C. of Pa.	61 S. Penna Ave.	W. H. Rippard.

CANADIAN EXCHANGES

Calgary, Alb.	M. F. C. of Canada, Ltd.	Lesson & Lineham Bk.	W. R. Marshall.
Montreal, P. Q.	M. F. C. of Canada, Ltd.	154 St. Catherine St.	A. R. McBeath.
Regina, Sask.	M. F. C. of Canada, Ltd.	312 Westman Chambers.	B. Witham.
St. John, N. B.	M. F. C. of Canada, Ltd.	Waterloo St.	C. H. Kerr.
Toronto, Ont.	M. F. C. of Canada, Ltd.	15 Wilton Ave.	Bert Moran.
Vancouver, B. C.	M. F. C. of Canada, Ltd.	329 Carrall St.	E. R. Fausler.
Winnipeg, Man.	M. F. C. of Canada, Ltd.	McDermott Ave.	J. H. Booth.



Trade Mark Reg.

Thanhouser Syndicate Corporation

71 West 23rd Street, New York

Produced by *Thanhouser Film Corporation*, New Rochelle, N. Y.
Producers of the *Million Dollar Mystery*.



Trade Mark Reg.

"When You See It
In 'The News'
It's NEWS"

Motion Picture News

HAS THE QUALITY CIRCULATION OF THE TRADE

"The Exhibitors'
Medium of
Communication"

Tel. 7650 Bryant

NO. 220 WEST FORTY-SECOND STREET

New York City

Volume X

NOVEMBER 21, 1914

Number 20

What You Owe the Exhibitor

TWO years ago one of the leading film makers made a thorough test of advertising to the public—and found it a complete failure.

The public responded and the exhibitor responded—in fact, every advertising result looked for was had. But *not a single extra print* was sold of the picture for which a demand was *successfully created*.

A NUMBER of other leading manufacturers are using the picture journals now—in their estimation—with about the same negative results.

Advertising to the trade *does not bring them any results*, they assert—that is, where their pictures go to the exhibitor as part of a program.

In proof of which, they call attention to the fact that much advertising or little advertising in the trade press for any length of time makes no difference whatever in the number of prints sold.

TO all of which there is but one answer; any business man will give the same—namely, that if no extra sale can result from an *exceptional* product *exceptionally* well advertised, then there is something *exceptionally peculiar* about the method of distribution.

WE have no desire to meddle with this rather big problem. It has been meddled with a good deal.

Those directly concerned with it know more about it than any journal does; and, at any rate, we may be sure of this—that forces bigger than men will eventually work it out *successfully* and *satisfactorily*.

We *do wish*, however, to present the exhibitors' side of the matter—and *also our side*—for the consideration of these same manufacturers.

TO every exhibitor who books your pictures *you owe something beside the pictures*. You owe him service.

You owe him, for instance, the regular business announcements that any manufacturer sends out.

What he wants and what he *must* have is *authoritative information from you* sufficiently in advance, to enable him to make as much money out of your pictures as he possibly can, and as is due him.

Advertising—to the public—pays him. *But how on earth can he advertise what he does not know about?*

THE MOTION PICTURE NEWS offers you an avenue for the distribution of these important weekly announcements *cheaper than the letter postage rates*—and ever so much *more direct* and *certain*.

This is economy for you. But there is still more.

Our readers look to us to carry these announcements for them. They charge it up to us if we don't get them.

They are right. It is part of the service, a most important part, which *we owe them*.

* * *

PERHAPS this light on the matter will explain in large measure why we solicit you so persistently for your advertising.

You often look upon it as a species of extortion on our part: we regard it as an absolutely necessary part of a comprehensive, efficient—well, just a *good*—trade journal.

You place your advertising, you say, purely as a matter of habit, or precedent, or sentiment: *we* regard it as a *necessity for our readers*.

* * *

YOU must remember this—that *the reader comes first with this publication*. We make it for him.

We owe you service, too; our success with you and for you will depend a good deal upon this. But, after all, the very best service we can give you is *circulation*—it's *everything* in fact—and we cannot give you circulation unless we put the *reader* and our service to him *first*.

He wants thorough, fair, dependable estimates of your pictures, your release dates, interesting news—real news—about your productions and plans—*all sufficiently* in advance; he wants your signed advertising announcements, *wants them more than we do*.

* * *

THIS is all part of the service which acquires circulation, and which *only* acquires circulation. Study carefully this issue of MOTION PICTURE NEWS and see the other service we give the reader.

The journal that offers you a big write-up in connection with your advertising isn't giving you real service.

Of what use is the write-up if the journal has no circulation? And rest assured of this fact—the "write-up" journal *never had, never will have a circulation*. It puts you first and the reader last. It wants your advertising for itself, not for the reader.

* * *

IN conclusion, then, your advertising problem is not complex, whatever your manner of distribution. If you feel you owe your advertising to the exhibitor as a service, as a part of your pictures, and as a matter of selling and distributing expense, all you have to do is to select the medium which reaches him. Then *you* will reach him.

The medium which *reaches* him is the one that *puts his interests first*—that is *genuinely* and *completely* an *exhibitors' publication*.

WILLIAM A. JOHNSTON.

TEXAS CONVENTION A RED-LETTER DAY

At Exhibition, Drawing Attendance from Louisiana, Oklahoma and Other Southwestern States, Manufacturers Are Well Represented—In Three Days 341 Exhibitors Registered—Guests Dance Until the Wee Sma' Hours

Special to MOTION PICTURE NEWS

Dallas, Nov. 9.

THE Southwestern Motion Picture Exposition, held in Dallas, October 25, 26 and 27, was a great success from all angles.

A large two-story building in the downtown district was equipped for the exposition, the downstairs floor being divided into booths, and the upstairs floor used for an auditorium.

The exhibit booths were decorated in many colors, as was the exterior of the building; and practically every film exchange and supply concern in the Southwest was represented.

Those having exhibit booths were: Eclectic, Apex, Lewis System, Box Office, Cremona Musical Instruments, Southern Film, Trash Film, Sanzone, Violano-Virtuoso Musical Instruments, Southern Theatre News, Southwestern Picture Inspection Bureau, Dallas Film, Sawyer, Consolidated Film, Big Four Feature, American Seating, Dallas Scenic, Blinkhorn Film, Alco, Wurplitzer, Paramount, United Theatre Chair, Photo Drama, Warner's, World Film, and Atlas Metal Works.

In the auditorium screens were stretched and machines installed, and, during the day and evening feature films were shown.

The Motion Picture Exhibitors' League of America, Texas Branch, No. 18, met, and as invited guests many members of Oklahoma, Louisiana and Arkansas branches were in attendance at these meetings.

Exhibitors were admitted to the building free, their badges acting as passes, but outsiders were charged a nominal sum admission. It is estimated that five thousand "fans" visited the exposition building daily.

The opening day, Sunday, was spent in registering the visiting exhibitors and providing them with badges, and there was very little outside entertainment.

On the morning of the second day, at 10 a.m., the M. P. E. L. met in the auditorium, and also met again at 2 p.m., and at the same times on the third day.

Monday noon, about five hundred feet of motion pictures was taken of the exhibitors and supply men in and around the exposition building, by Cameraman Fitzhugh. This reel was finished up with scenes at the State Fair Grounds and local views and will be booked over the State.

Monday afternoon, the league elected the following officers to serve for one year: T. P. Finnegan, Dallas, president; John Davis, Houston, first vice-president; G. K. Jorgenson, Galveston, second vice-president; J. C. Clemmons, Beaumont, secretary, and Ed Besserer, Austin, treasurer. A grievance committee was appointed consisting of members Ridout, Xydias, Besserer, Campbell and Finnegan.

At 8.00 p.m., Tuesday night, the exhibitors and supply men and their ladies were guests at a banquet and entertainment at the Oriental Hotel. A hundred and twenty-five plates were laid. After the banquet, short talks were made by T. P. Finnegan,

of Dallas; E. H. Hulsey, of Houston; G. K. Jorgenson, of Galveston; B. H. Powell, of Oklahoma City; Ned E. Depinet and others.

After the short talks, the guests formed their chairs in a circle around a temporary stage, where a four-act vaudeville was arranged by James B. Kelly, of the entertainment committee.

Louis St. Pierre, of the Dallas Scenic Studio, was first on the program, with a clever magic stunt, winding up his act with a rapid artistic water color sketch.

Mrs. Marguerite DeOrto was next presented and entertained the guests with some beautifully rendered songs of the day.

Joe Gilligan, of the Blinkhorn office, then occupied the stage, and told some very laughable Irish jokes. He also gave a good reading of John Hay's "Jim Bludsoe."

The last act was a burlesque "Mind Reading" act, presented by Tomes and Walker, of the Southern Theatre News. When Walker, who played the part of the "Mind Reader," said that Arthur Geiss' (7 feet 4 inches tall) nationality was "Pole," the "act" was nearly broken up by laughter.

After the vaudeville, the banqueters enjoyed dancing until a late hour, and when the gathering was finally broken up, everyone left with a smile of happy enjoyment.

"The Lure," a picture prohibited by the

Dallas censor, was shown in the auditorium of the exposition building Monday night, being run exclusively for the motion picture exhibitors; but as admission was charged to outsiders at the entrance of the building, there was some newspaper talk of complications. A short inquiry was made by the municipal authorities, but on account of a statement being made before the picture was shown, that it was strictly for the exhibitors, no action was taken by the city authorities.

One of the novelties of the exposition was the miniature motion picture theatre installed in the Sawyer booth, where a continuous show was run.

Another of the features was the "Daily Extra" of the Southern Theatre News, which was published each morning during the exposition, giving news of the previous day's happenings.

A total of 341 exhibitors registered at the registration office during the three days, and it is estimated that at least a hundred exhibitors visited the exposition building after the registration office was closed in the afternoons.

The exposition was a success from every angle, and it is planned to hold such a meeting in Dallas each fall.

J. W. HILL, JR.

Newark "Bicycling" Rouses Ire of Exchanges

Three Houses Subscribing for Universal, Association, and Mutual Programs Give 12-Reel Shows for Price of 6 Reels

Special to MOTION PICTURE NEWS

Newark, N. J., Nov. 10.

A CRY is being raised here against the "bicycling" of films, and it is a loud one, so loud in fact that it has several times reached the ears of the distributing agencies. But, according to local house managers and exchange men, it was unheeded and the bicycling continues. It is not caused by bad business conditions, but by the desire of a few men to gobble up all the business in sight, and they aren't a bit particular what means they use to achieve their purpose.

"As far as bicycling is concerned," said Leo Singer, manager of the Special Feature Film Company of 288 Market street, "the conditions in Newark and vicinity are worse than in any place where I have ever done business.

"It is hurting the manufacturers, the exchanges, and the theatre men themselves. The manufacturers aren't getting paid for the extra wear and tear on their film. The exchange man can't get a reasonable price for what he has to sell, and the exhibitor who tries to play fair is unable to meet the cutthroat competition and sees his business floating away from him.

"The bicycling here is generally done with regular program service. I know cases where three houses subscribing for Universal, Mutual and Association programs swap films, and each gives a twelve

reel show for the price he should be paying for a six or seven reel entertainment.

"Complaints have been made to the New York exchanges, but they are unheeded. It is about time, I think, that the exchanges got together and put a stop to this business.

"I am a member of the Feature Film Renters' Association of New York and New Jersey. If we find an exhibitor bicycling our films, without permission, we charge him up for the full amount of the stolen service. If he refuses to pay we won't let him have any more films, and he can't get them from any member of the association.

WHERE TO FIND IT

Department	Page
Live Wire, Exhibitors.....	25
Among the Exchanges.....	35
In and Out of Los Angeles Studios	29
Editorials	33
Feature Reviews	38-44
Program Reviews.....	47, 48
Buyers' Guide	51
Current and Coming Releases,	50, 52
Release Dates for Ready Reference	54, 56, 57
ACCESSORY NEWS.....	69-82

Fever of Stock Promotion Rages in Detroit

Within Ten Days Half a Dozen Companies Are Organized to Produce Features and the Investments Seem Attractive Until the Public Learns That Those Engineering the Deals Lack Knowledge of the Business—Musicians' Union Demands Settled Satisfactorily

Special to MOTION PICTURE NEWS

Detroit, Nov. 10.

DETROIT and Michigan exhibitors, and those interested in the motion picture industry, *paste this in your hat*: MOTION PICTURE NEWS will have its headquarters at the Hotel Pontchartrain. Drop in any time and ask for Mr. Thornburg, or you can get him on the phone, Main 6580. Always glad to get news items and meet the fellows personally.

Within the past ten days the writer has been informed that there are at least a half dozen companies being organized for the producing of feature pictures. The men promoting these enterprises are not familiar with the actual workings of a motion picture producing company, and yet they manage to tell prospective stock purchasers what other successful producing companies have done.

As yet none of these proposed companies have come to a focus, and it is to be hoped that none of them will materialize unless men are placed at the head of them who actually understand the business.

No less than a half dozen, companies have failed in the past eighteen months because of the utter lack of experience and ability to properly manage and carry on the work, and today the only company that is producing in Detroit is the Esperanto company.

Men who buy stock in a producing company without knowing who is going to manage it might just as well write the word "stung" across the face of the certificate, and use it as a souvenir for their den.

Sunday Opening Defeated

The Sunday theatre proposition in Kalamazoo, Mich., lost out at the polls November 3. The complete vote shows 3,034 in favor of Sunday shows and 3,087 opposed to it. While it has not been definitely announced, it is understood that petitions will be prepared and that the question will be re-submitted at the municipal election next spring. The theatre owners feel that the question was not thoroughly understood by the people and many people failed to cast their votes either way.

The Detroit Theatre Managers' Association met on Saturday, October 31, to take final action on the scale of wages for the Detroit Musicians' Union, who had made demands of a 25 per cent. increase. The theatre managers discussed the subject pro and con and came to the conclusion that an increase, if any, should not be greater than five per cent.

This proposition was put to the union the following Monday and accepted. The new scale goes into effect at once. In the future the wages will be as follows for musicians playing in the picture theatres.

Where the price of admission does not exceed ten cents and location is within half a mile of the city hall, 49 hours per week, \$24.15; 52½ hours per week, \$25.20, and 56 hours per week, \$26.25, with leaders

receiving \$5 extra. Outside of the half-mile circle and inside of the mile circle, \$1.50 less per week. Outside of mile circle, \$3 less per week.

It should behoove every theatre manager to keep an eye on his electric wiring. Of late inspectors from the Public Lighting Commission have been calling at the various theatres to see if the electric wiring was satisfactory, and in more than one instance they were forced to ask that changes be made in order to comply with the city ordinance.

Fire Marshals Make Inspection

A number of deputy fire marshals have been in the Upper Peninsula of Michigan the past two weeks making inspections. In a number of cities complaints were made against theatres where the exits were kept closed during a performance. In several instances fines were imposed.

Daines and Nichols, of Ann Arbor, Mich., are making quite a success with motion pictures of "live doings" at the University of Michigan. At this season of the year, the thing of greatest interest is football. Pictures were made of the Pennsylvania game, and will also be made of the Cornell football game. Later these pictures were shown at the local houses, and attracted great student crowds.

It would be nothing new to say that Mary Pickford in "Behind the Scenes" broke all records for attendance in Detroit.

PROOF OF THE PUDDING

Motion Picture News,
220 West 42nd Street,
New York, N. Y.

Gentlemen: Received my first copy of your paper this morning and after giving it the "once over" want to say it sure came up to my expectations.

Respectfully yours,
Art E. Koch,
Crescent Theatre,
315 Superior Avenue, N. W.,
Cleveland, Ohio.

Gentlemen: I cannot get along without your "News."

Cordially yours,
W. A. Calihan,
Hippodrome, Rochester, N. Y.

Gentlemen: Herewith money order for \$2.00 for one year's subscription. Please start with the first week in August, sending me the back numbers from that date.

This looks like a live publication and I want it.

Yours truly,
H. H. Daniels,
Oswego, Kansas.

Gentlemen: I have received my first copy of Motion Picture News and am highly pleased with it.

Yours truly,
R. D. Willis,
Del Rio, Texas.

This picture was shown the week of November 1 at the Washington, and it is safe to say that over 50,000 people paid admission to see it.

Miss Pickford is getting more popular every day, and it won't be long before even the Washington will be too small to hold the crowds that will want to see her. In this connection a word of praise might be said in behalf of the Famous Players company, producers of the Mary Pickford features. The plays are well chosen, and the photography in all of them is excellent.

The New Alhambra Theatre at Woodward and Kenilworth avenues, Detroit, opened on November 14. John H. Kunsky is at the head of this new house, while T. D. Moule will be the house manager.

Rosedale Seats Thousand

The new Rosedale Theatre at Rosedale and Woodward avenues, Detroit, according to its proprietor, William F. Klatt, will be ready to open about Thanksgiving Day. It will seat over a thousand people and play pictures exclusively.

The Detroit Creamery Company rented the Grand Theatre on Thursday afternoon, November 5, and gave a special exhibition of the film, "A Trip Through Dairyland" for the benefit of their drivers. The picture was made some weeks ago by H. A. Nelson. The picture shows how milk is put through the various processes of filtering, pasteurizing and bottling.

Eddie Murphy, manager of the Bijou Theatre in Saginaw, Mich., was a recent visitor in Detroit. His wife has been very ill, but is now on the road to recovery. As soon as she is strong enough she will take up her permanent residence in Saginaw. Mr. Murphy, who was formerly assistant manager of the Columbia in Detroit, has purchased the Bijou.

AL V. THORNBERG.

ELECTRIC CUTS PRICE OF FEATURES

Special to MOTION PICTURE NEWS

Philadelphia, Nov. 11.

The Electric Theatre Supply Co. announces a radical reduction in special feature films.

In future their price will be only \$1.50 per reel. This will place the best features within reach of the smaller theatres, and enable them to please their patrons without loss.

ANOTHER THEATRE FOR FRISCO

Plans are being drawn by Architect William Beasley for the erection of a four-story class A theatre and store building to be erected at Fourth and Market streets, San Francisco, Cal., for interests represented by Sid Grauman. The Peerless Theatre, conducted under the management of Nate Herzog, occupies a portion of the two-story structure now on the site.

FRANK LLOYD MADE DIRECTOR OF NEW UNIVERSAL

Because of the excellent showing he made while directing the Turner Special Feature Company during Mr. Turner's trip east, Frank Lloyd is soon to be given a post as director of a new Universal company organized especially for him.

George Larkin, present masculine lead with the Gold Seal Company, is to be made Mr. Lloyd's lead. Playing opposite him will appear Helen Leslie, one of the youngest of the Universal stars, who, though less than four months in pictures, is already on the high road to success.

Mr. Lloyd himself will play the heavy character leads and Marc Robbins, formerly of the Kerrigan-Victor company, will also be enrolled with the new company as character man.

The films are to be released under the Rex brand.

AFTON MINEER, BEAUTY UNDERSTUDY, MAKES HIT

Afton Mineer, the charming understudy of Margarita Fischer, of the Beauty company, recently played leads in the Beauty productions and proved herself exceptionally popular from the start. She will appear more frequently in the future for the delectation of film fans.

In "The Tightwad" Miss Mineer does some very clever dramatic work in emotional parts.

The subjects are in great demand here as well as abroad.

Rolfe-Alco Role Requires Spirit and Daring

And Mabel Taliaferro, an Expert Horsewoman, Proves Equal to the Demands of a Difficult Part in "The Three of Us."

MABEL TALIAFERRO, who is to star in the Alco release of December 14, "The Three of Us," is exceedingly athletic. And it is well that she is so. Many of the scenes of the former Madison Square success are laid in a mining camp. Rhy MacChesney, the role which Miss Taliaferro plays, is a girl well able to hold her own amid her Western surroundings. She rides, and on one occasion there is a spirited race with a railroad train. On the little stage of the Madison Square, which had more than the usual limitations of the legitimate, such scenes were impossible. But in the photoplay, which the B. A. Rolfe forces are preparing, the Western adventures are presented in detail.

Miss Taliaferro began her career at the age of two in "Blue Jeans," and became a very popular child actress. She was with Chauncey Olcott and Katie Emmet. Other engagements as a child actress were in "Patent Applied For," "For Fair Virginia" and "The Price of Peace." Her first big success as a young woman was in Israel Zangwill's "The Children of the Ghetto." Later she joined the Irish Players of Lady Gregory. Under this noted Irishwoman's direction Miss Taliaferro appeared in a number of plays of William Butler Yates, the Irish dramatist and poet.

On her return to America she found herself firmly established. One of her first parts was the title role in "Lorna Doone."

She next appeared as Lovey Mary in "Mrs. Wiggs of the Cabbage Patch." Stardom came to her with her appearance in "In the Bishop's Carriage." She followed this with Robert Browning's "Pippa Passes." In 1908 she made a notable hit as "Polly of the



MABEL TALIAFERRO

Circus." She played this role for three years. Then came her engagement in "Springtime," by Booth Tarkington, which made an instant hit.

Morosco and Cort Allied with Bosworth, Inc.

Junction of These Two Producers With Coast Firm Gives Paramount Program Greatest Array of Theatrical Magnates in the Field

AS a further indication of the remarkable development of the feature film, it is now officially announced that John

pany, have at last entered the film producing field, having just effected an affiliation with Frank A. Garbutt, of Bosworth, Inc.

This is one of the most significant alliances ever effected between important theatrical and motion picture interests, and attaches greater prestige to Bosworth, Inc., by reason of the fact that these producers have been approached at various times by the leading motion picture producers of the country with offers for a similar junction of interests.

Among the dramatic triumphs that have been produced by John Cort and Oliver Morosco, which will now be presented to

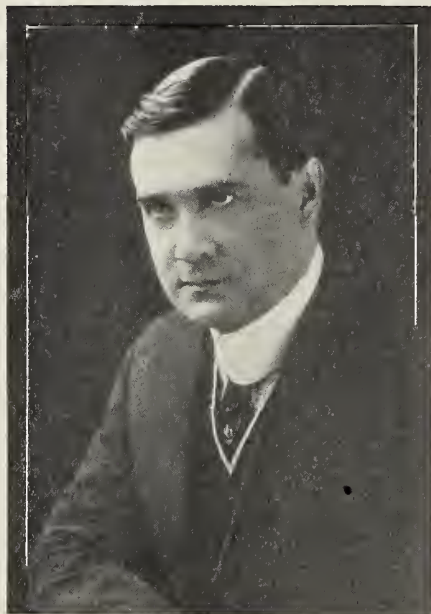

OLIVER MOROSCO

Cort and Oliver Morosco, under the name of the Oliver Morosco Photo Play Com-



JOHN CORT

the motion picture public are "Peg o' My Heart," "Bird of Paradise" and "Help Wanted."

As is commonly known, Bosworth, Inc., together with the Famous Players Film Company and the Jesse L. Lasky Feature Play Company, comprise the Paramount Pictures Corporation. The Famous Players Film Company are affiliated with Daniel and Charles Frohman, and Henry W. Savage. The Jesse L. Lasky Feature Play Company are associated with David Belasco and The Liebler Company, and with the addition of John Cort and Oliver Morosco in association with the Bosworth, Inc., as reported above, it may be now positively stated that the Paramount program will now distribute the dramatic output of the greatest number of powerful theatrical producers that ever contributed to a single film program.

S. & P. SUPPLY INCREASES ITS CAPITAL STOCK

Special to MOTION PICTURE NEWS

Louisville, Ky., Nov. 11.

The S. & P. Film Supply Company has filed amended articles of incorporation increasing the capital stock from \$1,500 to \$15,000. Manager Fred Sheldon says that the company is going to branch out into a wider field and needs more capital to carry on the business. All of the additional stock has been subscribed for.

A Firm That Will Interpret the Spirit of the West

California Motion Picture Company Will Produce Plays Imbued with the Atmosphere of the Pacific Coast, Its Romantic Aspect as Exemplified in Bret Harte's Masterpieces and the Distinctive Temperament of the People Whose Influence Has Helped to Mould the Country

HERBERT PAYNE, president of the California Motion Picture Corporation, and Alexander E. Beyfuss, general manager, recently spent a few days at the Ritz-Carlton. Mr. Payne came from the war zone in Europe. Mr. Beyfuss came direct from San Francisco. The latter brought with him the prints of the second production of the California corporation, "Mrs. Wiggs of the Cabbage Patch." "Mrs. Wiggs" and "Salomy Jane" were exhibited privately at the Alco projection room for the benefit of Mr. Payne.

To a reporter at the Ritz-Carlton, Mr. Payne and Mr. Beyfuss told something of the origin, plans and ambitions of the big Western producing ally of the Alco Film Corporation.

He got in touch with Alexander E. Beyfuss, who is one of the live wires among the men of affairs in San Francisco. They determined to go into the production field upon a large scale.

Effect by Able Co-operation

So the California Motion Picture Corporation was born. Mr. Payne became its president and Mr. Beyfuss its general manager. Henry T. Scott, chairman of the board of directors of the Pacific Telephone and Telegraph Company; president of the Mercantile Bank, of San Francisco; a director of the Bank of Burlingame; Crocker National Bank; the Oakland, Antioch and Eastern Railway Company and the United Railroads of San Francisco, became vice-president and treasurer.

Charles Templeton Crocker, president of the Crocker Hotel Company, and director of the Crocker National Bank, became a member of the board of directors; Arthur Payne, brother of President Payne, and secretary of the Payne Estate Company; and Christian De Guigne, of the Parrott Estate Company, also became members of the board.

Then the work of organizing the forces began. A strong company was at once engaged for the initial production "Salomy Jane," headed by Beatriz Michelena as the star.

While the company was being selected, business agents of the California Motion Picture Corporation purchased a large tract of land on the outskirts of San Rafael, which is about as far from San Francisco as some of the more distant towns of Staten Island. Eight acres were set aside for studio and laboratory purposes. The entire tract, available for production purposes, presents an unusual variety of scenery.

It is an open secret that many of the artistic effects in "Salomy Jane" and the forthcoming release, "Mrs. Wiggs," are due to the general direction of Mr. Beyfuss, but he will not admit the fact.

"We got the effects which the public seems to admire so much in 'Salomy Jane' through the able sort of co-operation," said Mr. Payne. "During the progress of 'Sa-

lomy Jane' we had many conferences which were participated in by our two head camera men, our directors, the heads of our various departments, the star, Beatriz Michelena, and, as the occasion demanded, laymen and other members of the company.

"The result was that we got the benefit of many minds, all working for one purpose, to portray for the entire country the spirit of the West as we know it and love it, and as Bret Harte pictured it.

"There is one thing I wish to impress upon you. We are ambitious to make the California Motion Picture Corporation the best and most artistic producer in the country. We realize that we could only do this by attention to detail. Consequently nothing was too small for us to overlook. Some of the film critics have spoken of the 'crystal' photography of 'Salomy Jane.' That crystal photography was attained in this way: We never took a picture on a bad day; we waited until the conditions were perfect.

"In 'Mrs. Wiggs of the Cabbage Patch' the public will see again that we have given every attention to detail. When the usual producing organization puts on a courtroom scene, the staging is usually left absolutely to the directors. We did not do this, however. When we were ready to proceed with this scene we engaged one of the leading lawyers of the Pacific Coast, Theodore Roche, to supervise the detail.

"Blanche Chapman played Mrs. Wiggs in the legitimate, when the Liebler company presented successfully for a number of years the 'Wiggs' play, written by Annie Crawford Flexner, and founded upon Alice Hegan Rice's stories, 'Mrs. Wiggs of the Cabbage Patch' and 'Lovey Mary.' Miss Chapman played Mrs. Wiggs for us. In accordance with our system of attention to detail we had Miss Chapman supervise the scenes of the legitimate play which had been specially admired and which we were using in the photoplay.

The Public's Verdict

"In 'Salomy Jane' we have had the verdict of the public. Attention to detail, as well as attention to the big things, pays. We believe that in 'Mrs. Wiggs' we shall have a similar verdict.

"We shall give to the public 'Mrs. Wiggs of the Cabbage Patch' and 'Mignon,' with Beatriz Michelena as the star, and then we shall return to western themes. In these two productions we plan to show the public that we can compete with any eastern producing organization. But aside from this, we believe that we have a peculiar field. We are native Californians, filled with the spirit of California, and we wish to present to the work in photoplay form in such a way that it will live—the heart and essence of California and the golden west."

Omaha Suffers From Unjust License Law

Ordinance Not Sufficiently Elastic to Give Managers Taking Out Application After January Full Twelve Months' Privilege

Special to MOTION PICTURE NEWS

Omaha, Neb., Nov. 10.

THAT an unjust license ordinance operates to restrict the erection and opening of motion picture theatres in Omaha every fall has been brought before the city legal department. As yet the city has taken no step toward remedying the situation. The problem exists in every other city the same as here, they contend, and no better system is known.

When Jacob Marks opened the Clifton Theatre at Yates and Military streets recently, he had to pay the same license charge as if he had opened it last January. And his license, the same as if he had secured it last January, will expire the first day of 1915.

When C. M. Sheeley opened the Wonderland Theatre at Thirteenth and Vinton streets a few weeks ago, he had to pay thirty-five dollars for a license that had less than four months to run. William Bock, when he opened the Bock Theatre in Council Bluffs, encountered the same unjust ordinance.

Unless they secure such a license, the ordinance provides, they can be arrested and their theatre closed.

In the fall is the ideal time for motion picture theatres to open. The latter part

of the summer is an ideal time to build them. But to many, just starting in the business, the unfair proposition of paying the license fee for only a short time means a loss they can not well afford. Every man who starts a motion picture theatre is not a millionaire, and to many their investment represents all they have.

Concentrated action would help. The present state of competition, however, does not look favorable for such action. The problem is a serious one here, and is becoming more serious every year.

"WORTH ITS WEIGHT IN GOLD"

St. Catherines, Ont.

"Motion Picture News,"

Gentlemen—It is with great pleasure that I enclose post office order for \$2, for which please send me "Motion Picture News" for another year. The valuable suggestions offered in your "News" every week is exceptionally good, and it is worth its weight in gold to any exhibitor.

With best wishes for continued success, I am,

Yours very truly,
GEORGE J. FORHAN,
Griffin's Theatre.

SOME OF THE STARS WHO WILL APPEAR IN BOX OFFICE ATTRACTIONS PHOTOPLAYS



DOROTHY DONNELLY

WILTON LACKAYE

EDMUND BREESE

CLAIRE WHITNEY

FAMOUS PLAYERS SIGNS MARIE DORO

The Famous Players Film Company has secured the exclusive motion picture services of that celebrated young star, Marie Doro, who has one of the largest metropolitan followings of the younger stars. Miss Doro has recently won added lustre by the distinction of being selected as co-star with



MARIE DORO

William Gillett and Blanche Bates in the present season's important revival of "Diplomacy," one of the more notable of the current Charles Frohman productions.

Famous Players will present Miss Doro in her greatest dramatic success, "The Morals of Marcus," by William J. Locke. This production attained such popularity at the time of its stage appearance that it is hardly necessary to recall the role created by Marie Doro.

The film production of "The Morals of Marcus," like that of "Zaza," will be released by the Famous Players-Charles Frohman company.

Box Office Engages Array of Broadway Stars

Farnum, Richman, Breese, Dorothy Donnelly, Claire Whitney, Edward Jose, Richard Buhler and Stuart Holmes to Appear in Fox Photoplays

A NOTABLE galaxy of stars now forms The Box Office Attraction constellation at the William Fox Studios. William Farnum, appearing with great success in "The Battle Cry," and Charles Richman have recently joined the other leading lights there.

Apart from Farnum and Richman, there now are with the Fox forces Edmund Breese, to be featured in the Hackett production, "The Walls of Jericho," by Alfred Sutro; Wilton Lackaye to appear in Israel Zangwill's "The Children of the Ghetto." Dorothy Donnelly in Daniel Frohman's production of "The Thief," by Henri Bernstein; Edward Jose, to appear in "A Fool There Was," the Klaw & Erlanger production of Porter Emerson Browne's masterpiece; Richard Buhler, in the supporting company of Dorothy Donnelly in "The Thief," and Claire Whitney and Stuart Holmes, popular moving picture idols, featured in the Victoria Cross novel and play of world-wide reputation, "Life's Shop Window."

William Farnum will appear in "Samson," one of Henri Bernstein's great achievements. "Samson" offers him an ex-

cellent opportunity. The play revolves about a financial giant who effects his own ruin in order to wreck his vengeance on the man who tries to destroy his home. Edgar Lewis, the producer, expects to make the "pit" scenes the most realistic ever staged in moving pictures or on the legitimate boards.

Charles Richman, being featured by Daniel Frohman in "The Man From Home," will star in the production of "The Idler," by C. Haddon Chambers. This is one of the most elaborate picture plays coming from the William Fox Studios.

Frank Powell, the eminent producer of features, who has recently come back to the William Fox fold, left on Monday for St. Augustine, Fla., with a company of stars. Mr. Powell is now engaged in the picturization of the original Klaw & Erlanger production of "A Fool There Was," the Porter Emerson Browne masterpiece. Mr. Edward Jose, often referred to as the Richard Mansfield of the "Movies," has been engaged to play the role Robert Hilliard took in the original. Mr. Powell has chartered a private yacht to take his company to the land of sunshine.

Pittsburgh Screen Club Well Under Way

Dresner and Herring, Exchange Men, Head Movement—First Entertainment Held November 15 at Fort Pitt Hotel—Banquet Follows Business Meeting

Special to MOTION PICTURE NEWS

Pittsburgh, Nov. 10. "THE Screen Club of Pittsburgh" is to be the name of a new organization in this city and all persons connected with the motion picture industry are eligible to membership. The organization is well under way and is being fathered by A. Dresner, of the Warner's Features, and Max Herring, of the Eastern Booking Offices. Both men are managers of the concerns they represent here.

There is not an idle moment in the lives of these two business hustlers and they have conceived the idea that it would be a good scheme to get all the fellows together and have a club where they could meet and hold their social gatherings.

The object of the club is to promote better feeling between the exchange men and the exhibitors and they want to see their get-together policy established on a solid footing and that as quickly as possible.

The first affair of the organization is to be held at the Fort Pitt Hotel, Pittsburgh, on the evening of Sunday, November 15, and a number of prominent persons, including Mayor Joseph G. Armstrong, have been asked to address the gathering.

The affair will be in the form of a banquet and business meeting. Rabbi J. Leonard Levi has also been asked to address the gathering and as he has always taken a lively interest in the motion picture industry from an educational standpoint, it is possible that he will accept the invitation.

LIVE WIRE EXHIBITORS

EDITOR'S NOTE.—It is the desire of "Motion Picture News" to include under this heading novel advertising ideas, successful schemes in the management, decoration and equipment of the theatre—everything, in fact, done by the exhibitor to stimulate his trade. We invite every exhibitor to write us about any new enterprise he has; also to come to us for advice or information along any line. Address: Editor, "Motion Picture News," 220 West Forty-second Street, New York City

TOMMY THOMPSON'S PROGRAM POSTER AND ITS RECORD

TOMMY THOMPSON, manager of the Columbia Theatre in Fifth avenue, Pittsburgh, has originated an idea that has assisted materially in drawing the crowds into his theatre. Tommy always was ready with the boosting proposition and the result has been one of big financial gains with regard to his motion picture theatre.

He has arranged a large poster which he uses in the form of a special bulletin. He takes a small part of his morning to arrange the material, such as stills taken from the reels he is running that day, press notices, a synopsis of the plays and pictures of the actors in the plays of that day. These he arranges in a manner most attractive and has it in the center of his lobby besides his other posters.

It is surprising how many persons stop and look the special bulletin board over and then go into the theatre. There is something attractive in the scheme and Tommy says he has greatly increased his receipts since he started using it.

The Columbia Theatre has been renovated from top to bottom and repainted and is now one of the most attractive theatres on the avenue. Thompson says it is a real nickelodeon now.

CATERING TO THE HOUSEWIVES

ALL day long, and especially in the morning hours, neat rows of baskets,

bags and bundles and a few go-carts are seen lined up before the Leader Theatre, Washington, D. C.

"Yes, I cater to the housekeeper," commented Nat Glaser, the manager, surveying these wares, "and I find it a paying proposition. It is not comfortable for shoppers to sit in the seats laden with bundles or have some one pass them with protruding packages, so by relieving my patrons of these, they can enjoy the show more readily.

"We are the only house opening at 9 o'clock in the morning, and you would be surprised at the attendance we have during the next two hours. A good portion of these are housekeepers doing the day's marketing or the early shoppers of the shores.

"In some cases these patrons are suburbanites, who would have no other chance of seeing motion pictures, and in some cases they are the busy housekeepers of the resident section who believe in getting an early start in everything, including entertainments.

"Saturday nights we wish our lobby were much larger, as it is the night for family buying and our reputation for looking after bundles and baskets is heavily taxed. We are pleased to have this patronage of the housekeepers."

HE NEEDS TWO BOX-OFFICES

TWO separate box offices is the scheme Manager George Fischer, of the Alhambra, Milwaukee, has hit upon to

dispose of more of his twenty-cent seats. In the front of the theatre in the usual little coop sits the girl who sells the ten-cent tickets.

On this box office is a sign announcing that the twenty-cent reserve seats are on sale on the inside. Just at the end of the long lobby is situated the regular theatre box office and it is here that the twenty-cent seats are sold.

This distinction in the place where the tickets are purchased makes it out of the question for the average American man to buy anything but the best seats, especially if he is with a lady, and the result has been that Mr. Fischer has almost doubled the sale of his reserved seats since he opened the two box offices. Even after a ten-cent seat has been purchased, many of his patrons change them for twenty-cent seats when they see the box office.

\$500 A WEEK FOR THEATRE PUBLICITY

AN average of \$500 per week is to be spent for local newspaper and billboard advertising for the feature pictures shown at the National theatre, Los Angeles, the largest Main street house, located in the retail district, according to a contract made with Manager Bert Lustig by H. E. White, of the Nat A. Mag-nar Company, Los Angeles branch.

The National, which was opened last February, has always been a five-cent house, showing regular Universal and Mutual program. With the change in policy to features, Mr. Lustig will follow the trail of managers of all the larger theatres of this city and increase the price to ten cents.

This contract sets a new record for progressiveness on the part of the film renter with regard to advertising, and, in fact, instances where the exchange spent anything for advertising films—unless they were placed in the theatre on a per cent.—have been very rare.

The advertising through the newspapers will be very beneficial to the exchange with reference to the smaller cities of this state and Arizona. It is held that better prices can be obtained from the small town exhibitors if the pictures are advertised and the public generally becomes acquainted with them.

The first two weekly programs will consist of "The House of Bondage" and "Strangled in Paris," to be followed by "The Key to Yesterday," and all other releases of the Alliance program.



SCENE FROM "THE MAN FROM HOME"
(Lasky-Paramount Feature)

Mary Pickford Captures Philadelphia

Crowds Block Traffic in Effort to Enter Stanley Theatre for View of Star While She Sees Herself on Screen

Special to MOTION PICTURE NEWS

Philadelphia, Nov. 10.

TALK about your live wires! All who know Stanley Mastbaum need not be told that he is a daring and original exhibitor, but at last he has "out-Stanleyed Stanley."

It was no easy task to manage an overnight visit from such a busy and popular



THE PICKFORD PARTY AT THE STANLEY THEATRE, PHILADELPHIA

personage as Mary Pickford, but after untiring efforts for a month, every obstacle was overcome and all details arranged.

Mary Pickford has been in Philadelphia, spent an evening at the Stanley Theatre, has seen herself on the screen in "Behind the Scenes" and incidentally gave to the Stanley an evening's business unprecedented in its history, besides filling all the other large Market street houses with those who could not for "love or money" obtain admission to the Stanley.

"Little Mary" is a great favorite in Philadelphia, but this visit has proved that she is a magnet of the strongest drawing power. That Miss Pickford "came, saw and conquered" is but putting it mildly. Her presence packed the theatre to the doors from 7 p.m. until 11 p.m., and then there were literally hundreds outside patiently waiting a chance to see their idol. Miss Pickford, accompanied by her mother and Adolph Zukor, president of Famous Players, were escorted to the Bellevue-Stratford.

Here they were the guests of honor at a dinner given by Stanley Mastbaum to twenty people, including dramatic critics of the Philadelphia papers. Right after dinner the party motored over to the Stanley, where four stalwart policemen were holding the impatient throngs in check. Clasp ing a bunch of American beauties as large as herself, "little Mary" posed for the flash light man right in front of the theatre.

A spontaneous burst of applause attested the enthusiasm of the vast audience which vociferously demanded a speech. Miss Pickford, in a few graceful words, expressed her appreciation of the demonstration, her happiness at meeting so many Phila-

delphia friends, and her pleasure at witnessing one of her favorite roles, Dolly, in "Behind the Scenes." The crowd outside was made happy by the presence of the star for a few minutes in the box office, where she made another little speech.

Just as the last scene of the play was flashed on the screen, the audience made one wild rush and so surrounded Miss Pickford that even with the aid of four escorts she could hardly reach her taxi-cab.

For fifteen minutes traffic was held up on busy Market street, while the crowd surged hither and thither, trying for a last glimpse of their favorite.

This was Miss Pickford's first visit to any Philadelphia motion picture house, though she has been on a previous occasion a guest at Mr. Lubin's suburban home.

Miss Pickford, who has just signed a contract for \$1,000 a week with the Famous Players Company, was so simply gowned that a little stenographer was heard to remark, "Well, she makes in one week what I do in one year, and just look, I am more dressed up than she is. Can you beat it?"

The Pickford party was entertained at the L'Aiglon after the performance and left early in the morning for New York. On this occasion the Stanley management did not issue any reserved seat checks, the admission price being twenty-five cents straight for any seat or stand you could find.

IRENE PAGE SOLOMON.

BAGGOT OPERATED ON FOR EYE TROUBLE

Suffering from the effects of a piece of steel which had lodged in his eye during the enacting of the rescue scene during the recent fire in Fort Lee for Imp-Universals, King Baggot feels as though he had had enough of such performances for the present.

It was not until three days after the affair that the eye began to trouble him, but when it did start it became so painful that he was forced to have a minor operation performed. This kept him indoors for three days.

TALBOT RESIGNS MANAGEMENT OF HIPPODROME

Special to MOTION PICTURE NEWS

St. Louis, Mo., Nov. 9.

Frank L. Talbot has resigned the management of the Hippodrome, Sixth and Walnut streets, and David E. Russell has been appointed in his place. Mr. Talbot is a prominent figure in motion picture and vaudeville amusement circles all through the West. He entered the business in St. Louis by building the Gem theatre, one of the largest all picture houses in the country.

LEVY HARD AT WORK

E. A. Levy, of the moving picture information bureau, has assumed charge of the publicity department of the Excelsior Feature Film Company and can be seen at that office hard at work every day between twelve and one.

Lasky Signs Valeska Suratt for Two Years

First Picture Will Be a Subject Having a Modern Society Setting with Actress Gowned in Gorgeous Costumes

ANOTHER recruit to the ranks of prominent stars in the photo play realm occurred when General Manager Samuel Goldfish, of the Lasky Feature Play Company, secured the signature to a long term contract of Valeska Suratt.

Mr. Goldfish, for the past two months has been endeavoring to persuade Miss Suratt to put her name to a contract, but without avail. Undoubtedly one of the best known and most widely advertised of woman stars, Miss Suratt demurred owing to her pending engagements. She opens within a few weeks at a Broadway Theatre in an entirely new show, in which she will star.

There is a contract pending with the United Booking Offices calling for Miss Suratt's appearance for many weeks at a salary of two thousand dollars per week.

When "Bouffe Varieties" were produced by Miss Surratt, in which she was supported by twenty-five prominent players, the vaudeville world accorded her a plan for elaborate costuming. Her "Black Crepe and Diamonds," which served as a vehicle all last season, cost in the neighborhood of forty thousand dollars for hanging pieces and costumes alone, it is said.

The contract with the Lasky company stipulates that her first picture must be a modern society subject, staged in the proper environment and that Miss Suratt is to select her own costumes.

The contract runs from November 1, 1914, to November 30, 1916, and gives the

Lasky people the exclusive rights to her services for as many pictures as they desire.

Miss Suratt is the big star feature at the Palace Theatre which will probably be her



VALESKA SURATT

last vaudeville appearance until after her first picture.

The Suratt pictures will be staged at the Lasky studio, Hollywood, Cal., by Cecil B. De Mille.

Looking Ahead With The Producers

"MRS. BLACK IS BACK," NEXT FAMOUS PLAYERS RELEASE

America's foremost comedienne, May Irwin, in the title role of the film version of the most celebrated of all her stage triumphs, "Mrs. Black is Back," by George V. Hobart, is the next Famous Players subject to appear on the Paramount program, scheduled for release November 30. May Irwin is inimitable as the irrepressible Mrs. Black, who deceives her husband about her



MAY IRWIN IN "MRS. BLACK IS BACK" (Famous Players)

age, and who goes through a period of comic anguish as the result.

Miss Irwin appeared in the original stage production of "Mrs. Black" for many seasons, and in the five-part Famous Players feature this distinguished star even surpasses the merits of her stage performance.

WOOD RETURNS TO OLD POST

Cecil R. Wood has returned to his old post as chief operator for the New York Alco Exchange. Mr. Wood spent the past few months in the South selling Radium Gold Fibre screens.

Set Date for Lasky-Belasco Premiere

PROBABLY the most auspicious private showing yet conducted will be the premiere of the first Jesse L. Lasky-David Belasco release, "The Rose of the Rancho," which will take place at the Belasco theatre, in West 44th street, New York City, next Sunday night, at eight-thirty.

For the occasion Mr. Goldfish has issued one thousand invitations. The event will be under the personal auspices of Mr. David Belasco, and will be staged for the occasion by Mr. S. L. Rothapfel, manager of the Strand theatre.

Among the invited guests will be David Belasco, Mrs. H. C. De Mille, Professor Brander Matthews, Judge Dittenhoeffer, Cyril Maude, Adolph Zukor, Daniel Frohman, George M. Cohan, William Collier, Benjamin F. Roeder, Fred Stone, Dave Montgomery, R. Wanamaker, Mme. Nazimova, Julia Sanderson, Mr. and Mrs. Vernon Castle, Mitchel Mark, and the representatives of both the daily and trade papers.

Response invitations have been sent out, and upon receipt of reply reserved tickets will be forwarded, and admission to the

Belasco theatre will positively be on tickets alone.

A Wurlitzer organ, two projection machines and booth are being installed.



SCENE FROM "ROSE OF THE RANCHO" (Lasky-Belasco Feature)

A twenty-piece orchestra will furnish the melody. The occasion will long be remembered in film circles.

Kinetophote's "Coming Power" Soon Released

ONE of the most powerful political stories ever written for the screen is about to be released by the Kinetophote in "The Coming Power," a story of corruption in high places, written by Catherine Carr from a script by Raymond C. Hill.

The film tells a story of the power of money in politics and of the persistent and successful pursuit of an ideal. The love tale is woven into the plot with considerable ingenuity, and ends with an unconventional surprise which is effective.

The picture is directed by Edward Mackay, who is now chief director for the

Kinetophote. In the cast are Lionel Adams, now with the "Kick In" company, who was featured in "The Man of the Hour"; Edith Luckett, who is leading woman with Chauncey Olcott this year; Anna Rose, a favorite motion picture lead; William Crimmins, a Belasco player, and others.

ABELES IN "THE MILLION," WITH FAMOUS PLAYERS

Edward Abeles, star of "Brewster's Millions," "Charley's Aunt," "My Friend from India," and a long list of other celebrated

STARS AND SCENES IN KINETOPHOTE'S NEW FEATURE, "THE COMING POWER"



ANNETTE ROSE

"THE VULTURE" BUYS POLITICAL FAVOR HE BRIBES THE PROSPECTIVE GOVERNOR

EDITH LUCKETT

stage successes, is now engaged in the production of his first subject for the Famous Players' Film Company. The vehicle selected for Mr. Abeles' first appearance on the Famous Players' program is "The Million," Henry W. Savage's great comedy production, and is presented as the second Famous Players—Henry W. Savage release.



EDWARD ABELES

Edward Abeles will play the role of the Baron in "The Million," the clever and kind-hearted crook whose ingenious maneuvers finally succeed in capturing the much-sought-for lottery ticket, the recovery of which means the marriage of the two young lovers of the play.

"The Million" is scheduled for release on the Paramount program December 31.

THANHOUSER ANNOUNCES "ZUDORA" EPISODE NAMES

Much inquiry has attached to the titles of the episodes of "Zudora," Thanhouser's forthcoming serial. Mr. Daniel Carson Goodman, creator of this new photoplay, has exhibited in his title selections a faint hint of the mysticism and surprising revelations to be expected in this production. For the first time, the titles of the first five episodes are now made known. They follow: "The Mystic Message of the Spotted Collar"; "The Mystery of the Sleeping House"; "The Mystery of the Dutch Cheese Maker"; "Mystery of the Frozen Laugh," and "The Secret of the Haunted Hills."

In each of these episodes the author carries along his master plot through varied themes and wondrous diversity of situations. Dr. Goodman's work represents a new school in motion picture play-writing. This is a school of modern realism, and is said to be the greatest step taken so far in the motion picture industry toward the elevation of the silent drama.

Digby Bell In "Mr. Pipp" Coming Soon

THE Alco Film Corporation has set November 23 as the date for the release of Digby Bell in "The Education of Mr. Pipp," the production of the All Star Feature Corporation, and made under the personal direction of Augustus Thomas. It is a picturization of Mr. Thomas' play of the name, which is based on the famous Gibson drawings. The moving picture scenario was written by Mr. Thomas himself. Digby Bell, the star of the picturization, played Mr. Pipp in the legitimate for three years.

In the case of the legitimate play some effort was made to cast the play according to type. In the photoplay this idea has to be carried out more carefully. Each member of the picture cast has been chosen because of the marked resemblance to the Gibson original. The idea of the Gibson pictures has also been carried out in another way, for all of the localities which Gibson sketched in as background have been utilized in the photoplay. Something of the history of the Pipp family and their doings in Pittsburgh has been put upon the screen, and the house which they acquired in New York is shown in its proper Manhattan setting. Durland's Riding Academy, Central Park, and all the other resorts of the Pipp family appear.

Digby Bell, the star of the Alco release, "The Education of Mr. Pipp," makes his screen debut in that photoplay. He was born in Milwaukee in 1851, the son of a banker, a connection that few actors have obtained. Later he became a banker himself, and followed this by becoming a member of the Stock Exchange. He was general passenger agent of the White Star Line in New York as a very young man.

While closely engaged with business, Mr. Bell found time to study music. He soon discovered that he had a fine natural baritone voice, and in 1872 he went to Italy determined to study for the career of a grand

opera singer, which made a strong appeal to the young man.

Several years later he returned to America to appear as a concert singer at Chickering Hall, New York. A tour of the principal American cities followed. While this tour was very satisfactory Bell soon felt that he had had enough of music that is popularly termed classical. He turned to light opera in the John D. Martinez English Opera Company. After a tour of the United States the company struck difficulties in Montreal, Canada.

Bell followed his initial success in comic opera with many other instantaneous successes. He was John Wellington Wells in "The Sorcerer," and delighted the public in "Trial by Jury." A three years' engagement with the singing company of the late Augustine Daly followed. He was successful in "Zamina," "The Passing Regiment," "Needles & Pins," "Americans Abroad" and other operas.

In 1884 he was King Charles in "Nell Gwynne" at the Casino. Then came four years with the McCaul Opera Company, during which he sang leading parts in "The Black Hussar," "Indiana," "Boccaccio," "The May Queen" and many others. Ko-Ko in "The Mikado" was a part which has always been peculiarly associated with Mr. Bell. Other Gilbert-Sullivan pieces gave Mr. Bell many opportunities.

Comic opera stardom came to Bell in May, 1892, when he appeared in the title role in "Jupiter" at the Casino. He was successful in "The Princess of Nicotine" and "Girofle-Girofla," "Nancy Lee" and numerous other now forgotten pieces.

Having sung and played in grand and comic opera and light opera, Bell now showed another phase of his versatility. He turned to the legitimate and was just as successful as he had been in the musical realm of the footlight world.



TWO VIEWS OF DIGBY BELL AS MR. PIPP, AND A SCENE FROM THE SCREEN VERSION OF THE GIBSON CARTOON-DRAMA

In and Out of Los Angeles Studios

Special to MOTION PICTURE NEWS

Los Angeles, Nov. 9.
LILLIAN and Dorothy Gish, of the Majestic-Reliance companies, for the first time in their motion picture experience of several years are co-stars in a production. The picture is entitled "The Sisters," and is being produced in two reels by William Christy Cabanne. The sisters play the parts of unsophisticated country sisters. One becomes wordily wise, and the other retains her simplicity. The plot portrays their girlhood days and later motherhood. W. E. Lawrence and Elmer Clifton play prominent parts in the picture. Inceville has had a real fire, caused by a cigarette stub being dropped in the dry grass near the projection room. A blaze soon kindled, and the fire was first discovered great clouds of smoke were pouring from the structure. A volunteer fire department was organized at a moment's notice, and by the aid of plenty of water the fire was soon extinguished. The damage was slight.

Walter Edwards has just completed the filming of "The Cross in the Desert," a tale of hobo life, at Inceville. In this Mr. Edwards plays the part of a tramp who aids a young easterner to reach his dying wife in the west. The young man, forced to leave the train by orders of the superintendent, faces death on the desert.

The tramp, befriending the unfortunate man, compels the superintendent to exchange clothing with the tramp who proceeds on his way. In the clothing of the tramp the superintendent is denied accommodations by his own railroad, and after wandering about the desert comes upon the dead body of the young man he caused to be ejected.

Arthur Maude, an English actor, is to make his debut as leading man for New York Motion Picture Company releases in "The Master of the House," a drama of modern society life being filmed under the direction of Richard Stanton, at Inceville. Mr. Maude plays the part of the brother who induces his sister to wed a wealthy westerner (Richard Stanton), and then by the aid of mother and sister proceed to abuse the husband in every manner possible. The westerner, however, becomes the master.

Life in Holland

Frank Borzage, Lewis Durham, Herschel Mayall and Elizabeth Burbridge play the principal parts in "A Romance of Old Holland," which is soon to be completed under the direction of Jay Hunt. It is a story of life in Holland written by Thomas H. Ince.

Messrs. Borzage and Durham, together with Leona Hutton and Gladys Brockwell, will form the cast for "A Crook's Sweetheart," an underworld story to be filmed by Scott Sidney. This depicts the fate of a

double-crossing crook at the hands of a rival for the hand of a girl.

George Beban, engaged by Thomas H. Ince to play the name role in "The Italian," has been sent to Italy to make fifty-odd scenes for that production. Mr. Beban was accompanied by an Inceville cameraman, and will go direct to Naples from New York, and from that city to Venice, Italy.



EDITH TALIAFERRO

In the Ince picture the noted actor who for the past five years has been interpreting Italian character parts, his most noteworthy success being "The Sign of the Rose," plays the part of a Venetian gondolier in this picture, about whose advent into American and subsequent experience in the heart of a busy city the plot of the story is woven.

The direction of the scenes made abroad will be wholly in the hands of Mr. Beban, and he is to employ his assistants, actors and actresses there. It is planned that Mr. Beban can make the scenes needed for the picture and pass the Statue of Liberty on his return within a month from the time

he departed from Los Angeles. This will be possible, it is believed, for Italy has the reputation of bright, sunny days the year round, the same as southern California.

The trip of Mr. Beban and his cameraman was planned by Mr. Ince, who for months has been a firm believer in giving the motion picture lovers true realism. He has frequently argued that the days of the faked picture are past, and that a successful picture must have true settings, as well as realistic acting.

Begin Mrs. Carter's Play

Production of "The Heart of Maryland," with Mrs. Leslie Carter in the leading role, and William E. Shay playing the male lead, was begun last week at a local studio under the direction of Herbert Brennon for the Tiffany Film corporation of New York city.

The nucleus of the producing company composed of the three mentioned above, together with James McKay, George Fitch, George Stout and others recently arrived in Los Angeles in a special car. Mrs. Carter registered under an assumed name at one of the leading hotels, and it was not until later that it became known that the parties were in the city. In the meantime they had made arrangements for use of a commercial studio, secured office rooms, and a pretty furnished bungalow for the leading woman and her maids.

Messrs. Brennon and Shay are well known to many of the Los Angeles photographers, and these gentlemen were given a very cordial reception to the colony.

The Universal special feature company, under the direction of Otis Turner, is making a three reel picture from the well known story "Called Back," by Hugh Conway. The scenario was prepared under the direction of James Dayton, and very extraordinary effects are to be used. For London scenes a number of big sets have been made, including one that completely takes up all the unused space of the U lot.

Local mechanics have prepared a device to furnish fog for this setting, and one of the features will be the scenes of the London fog. The cast for this picture includes Anna Little, Herbert Rowlinson, Alan Forrest, William Worthington and William J. Quinn. It is the intention of Mr. Turner to spend extra time on this picture, and make it one of the big ones bearing the revolving globe.

"Threads of Fate" is a two reel allegorical picture from scenario by Thomas Forman of the U scenario department, being produced by Director Joseph De Grasse. The picture will feature Paulina Bush, and other members of the company playing in this are Lon Chaney and William C. Dowlan. The picture will depict the three fates at work, and show their effect upon the destinies of mankind.

ARE YOU USING IT? THESE MEN ARE. SEE PAGE 49

"It is no doubt a good thing and will be appreciated by your readers."
 —F. M. EDGITH, Lyric Theatre, Earlville, Ill.

"I think it will work out O. K."—
 HENRY KORLE, Cincinnati, Ohio.

STAR AND SCENES IN "THE TEAR THAT BURNED" (Majestic—Two Reels. November 8)



ORDERED TO WORK BY HER FATHER

LILLIAN GISH

CHINATOWN CHARLIE POSES AS A FRIEND

The Terrance O'Rourke company is sojourning in the Balkans, in the making of the fourth two reel picture of the series which will appear under the title of "The King and the Man." Several out of the ordinary sets have been prepared for this, and the natural scenery at the New Universal City will serve for the picture.

Saves Two Lives

In making the final scenes for No. 4 of "The Master Key" series at Universal City a test saved the lives of the two leading people. The explosion in the gold mine sent an ore car carrying Ella Hall over the trestle seventy-five feet above the ground, and she was rescued by Robert Leonard hanging by his knees from a mine bucket suspended from a cable crossing the track of car. Before the scene was rehearsed the car was first shot out of the mine twice. First it ran off the track on one side, and after being ballasted it ran off the other. The cable was tested by 500 pounds being placed in the bucket and shot across the canyon. When this was done it broke when about in the middle. The company is now making the fifth instalment.

The 101 Bison company, under the direction of Frank Lloyd, is filming an unusual comedy, "A Double Deal in Pork," written by Ruth Anne Baldwin, of the Universal.

The Sterling comedy makers under the direction of David Kirkland have filmed "Noodle's Return," in which Mr. Henpecked Husband comes into his own by the proper display of will power. The Frank Griffin company has made "Dot's Elopement," in which three autos were badly smashed. Bobbie Gould, late of the Oz company, and now permanently with the Sterling, is featured in this picture. The other Sterling picture of the week is "A Bear Escape," directed by Bob Thornby and played by the Kiddies. A make-believe and a sure-enough bear caused a rupture of a love affair.

Lumber Trust in Films

Calder Johnstone has written a very pretty one reel story, "At His Own Terms," in which the lumber trust attempts to force an old squatter to vacate, but when he finds and cares for the little son of the lumber king conditions are changed. The picture is being made by Director Charles Giblyn, of the U studio, and the cast in-

cludes Murdock MacQuarrie, W. K. Wilson and Agnes Vernon.

Allen Curtis and band of Universal Jokers are making a beach comedy, "The Water Cure," in which two jealous wives in an attempt to fool their husbands become too gay—entirely—for the beach police, and are locked up. The husbands, left on an island—that is an island when the tide is low—by the wives, are finally rescued but not until after the "better halves" are badly frightened. The cast includes William Farney, Gail Henry, Jack Francis and Louise Fazenda.

Hal Roach, at the Rolin Film company studio, is making the third of the Work family comedy series. In this "Willie Work Buys a Harem." The comedies are released through Sawyer, Inc.

Hobart Bosworth and company are still at Banning making exteriors for "Buckshot John" from a Charles Van Loan story of the same name, and according to letters had some real time in making a lynching scene in which five men were hanged. The trouble was caused by the horses not being accustomed to work of the kind, and the poor victims had to undergo the ordeal five times before the correct picture was made.

Hutchinson in Santa Barbara

Work has commenced on the Bosworth Company picture featuring Elsie Janis. The production of this is in charge of Phillips Smalley and Lois Weber, and the feature will consist of four reels. What picture will be taken up first has not been announced. It is understood that James K. Hackett, George Fawcett, Maelyn Arbuckle and Dustin Farnum have also been engaged for pictures to be filmed in the near future.

The Santa Barbara Motion Picture company has begun producing under the direction of A. M. Kennedy, who has just returned from the East, where he made arrangements for the release of a comedy each week and a three reel feature every two weeks on the Standard program.

There will be two companies organized, one for comedy which will be directed by Mr. Quirk, the other for drama to be in charge of Mr. Kennedy. The first release will be made about January 1. Mr. Kennedy was formerly manager of the Universal west coast studios.

S. S. Hutchinson, president of the American Film Company, with studio at Santa Barbara, Cal., spent a few days here with Manager Johns, of the Pacific Mutual Film Exchange, while on his way to Santa Barbara. It is understood there are to be changes made in the policy of the American company, and that several big pictures will be taken up in the near future.

Ulysses Davis, director at the Vitagraph Santa Monica studio, is in charge of the filming of "An Intercepted Conscience," from scenario by William Raine. This picture features Margaret Gibson, and the cast includes Jack Mower, George Stanley, Frank Ranous and Otto Lederer.

Neilan in Charge of Kalem

With the suspension of production by the Albert E. Hale Kalem company at the Santa Monica studio, because of Mr. Hale accepting the direction of a musical comedy company in the northwest, the studio has been taken charge of by Marshall Neilan, director manager of the Kalem Hollywood studio.

An additional company has been formed by Mr. Neilan, which is being directed by C. E. Ward. Marin Del Sais, who has been with the Kalem dramatic company at Glendale, is now with the Ward company, and Ethel Teare, formerly with Mr. Hale, is playing under the direction of Mr. Neilan.

The U zoo is short one Siberian wolf hound, Bingo, which tried to become friendly with one of the wolves engaged at the Universal City. Bingo had never been whipped before, and no one knows how long it took the wolf to do the job as Bingo broke into the cage at night. But Bingo is no more.

Francis Ford and Grace Cunard and other members of the company are at Catalina Islands, where a two reel water picture is being made.

G. A. R. Picture Full of Sentiment

James Dayton, in charge of the Universal scenario department, is taking a vacation which he is spending at San Diego.

"Seven and Seventy" is the title of a one reeler made by Charles Giblyn, of the U studio at the Sawtelle soldiers' home. It shows an old soldier winning the heart of a lad, and the parents of the boy taking

the veteran to their home that he may act as companion for the lad. While the boy and parents are absent from their home on a summer trip, the G. A. R. member passes away.

William Garwood, who has been directing and playing leads at the American studio, Santa Barbara, signed with the Imp company and finished his work on the west coast last week. Mr. Garwood has gained a reputation for being one of the best dressed men in pictures on the west coast, in addition to being a very capable director and actor, and he will be greatly missed here.

A Kite in Motion Pictures

Russell E. Smith, of the Majestic-Reliance scenario department, has introduced a kite in motion pictures as a way of sending a message for help. In this instance the plaything is found on a narrow ledge by a victim of fate. He ties a note to it, and it falls at the feet of his sister, whom he has not seen for years. The hero of the picture, played by Wallace Smith, is rescued. Irene Hunt is the sister and the picture is being produced by Fred A. Kelsey under the title "On the Ledge," a picture which will not fail to please the public.

"Who Shot Bud Walton?" is the title of a mystery film being made at the Reliance studio, with Sam DeGrasse as the scientific detective-sheriff, from the story of the same name by George Patullo. The mysterious murder is committed by a waitress, played by Francellia Billington, aided by R. A. Walsh and Eugene Pallette, gunmen, who have established a reputation for crook parts. The direction is in charge of Jack Adolphi.

Heart Interest Civil War Story

After the loss of two sons in the Civil War, a mother prevents her only other son from enlisting by the use of a gun. This forms the nucleus of the plot for a heart interest Majestic two reel picture being made by Donald Crisp. The part of the mother is played by Josephine Crowell. The son, Elmer Clifton, is court martialed for cowardice, but pardoned by General Grant.

Doping a decanter of whiskey in order that he may not be prevented from attending a masked ball by the interference of his wife, Baldy Belmont, who plays the name part in the Majestic comedy, "Her Brave Hero," gets away with a lot of new fun of the sober sort, and besides stealing a policeman's uniform when the officer is under the influence of the liquor, arrests a real crook who has tasted thereof, and, despite the fact that he attended the ball and returned, he becomes the hero, and is worshipped by his wife. Playing opposite Baldwin in this entertaining picture is Miss Billie West.

"A Lucky Shot" is a Reliance western single reeler in which the sheriff attempts to capture an outlaw. The bullet misses and chips off a piece of rock exposing a rich vein of gold. This incident brings about a pretty romance, a hold-up and a reformation of the outlaw. Arthur Mackley is playing the lead part and directing the production with his accustomed vigor and expert stage management.

Universal Revives Glories of Ancient World

"Damon and Pythias," the Immortal Story of Indissoluble Friendship, to Have Vivid Presentation in Elaborate Production

THE establishment of the Universal booking offices is considered to be one of the most progressive moves in the history of motion pictures. Realizing that big feature films such as "Damon and Pythias,"



"THE PARTING" FROM "DAMON AND PYTHIAS" (Universal—Six Reels)

"Neptune's Daughter" and "Traffic in Souls" must be handled just like the largest legitimate attractions, President Carl Laemmle has instituted the Booking Offices, its purpose being to take charge of all features of five reels or over. From these offices booking will be arranged, advance men will be sent out, advertising campaigns will be attended to and everything will be done on a par with the greatest Broadway success.

The first production to be released from the new Booking Offices will be the six-reel masterpiece, "Damon and Pythias." Probably among all former features of the company produced, none stands out as artistically and wonderfully realistic as this picture. It is a feature which will win merit everywhere and the intelligent directing of its producer is entirely evident.

The story told in "Damon and Pythias" is a story of the greatest human friendship that the world has ever known. It tells of an understanding between those two sturdy Grecian leaders, a bond which could not be severed by devastation, annihilation or violent death. It stands as a shining example of strength of character.

At the \$1,000,000 Universal City in California, Mr. Otis Turner, known as "the genius of the films," carefully mapped and planned the direction of the massive production. Whole cities were built, Grecian gardens were constructed, crude stone chiseled into statuary, the magnificent baths

of the ancient Grecians were duplicated and everything done to create proper atmosphere. The leading parts were given to Cleo Madison, Anna Little, Henry Worthington, Herbert Rawlinson and Frank Lloyd.

Nothing need to be said of the efficiency of these artists as their work is known the world over. To support them, 1,000 seasoned motion picture actors were employed.

The actual staging of the production was a tremendous undertaking. There were sensational chariot races, whole cities were set on fire, vast armies clashed and the many other colossal scenes presented countless obstacles for the camera and director.

Knights of Pythias all over the United States and Canada have endorsed the film, recommending that everyone see it and digest its wonderful moral. In each case the production has been proclaimed "one of the most wonderful pieces of work ever witnessed."

This feature will be shown simultaneously in New York, San Francisco, Boston, Chicago, and other large cities, following which the Booking Offices will send the



A WARRIOR GROUP IN "DAMON AND PYTHIAS" various shows on tour to be exhibited in the highest class theatres in the country.

GUS PHILLIPS ACTS AS JUDGE AT CONTEST

At the third annual reception of the Mosholu Club, of Bedford Park, recently held in the McKinley Square Casino, the Bronx, New York City, Augustus Phillips, the leading man of the Edison company was a guest of honor with Governor Glynn, Park Commissioner Whittle and Congressman Goulden.

An interesting show was staged and motion pictures of scenes about Fordham, taken by the Edison cameraman, were exhibited.

A novel feature was the club contest, in which talented members of local social organizations staged sketches in hopes of winning the prize, a silver loving cup. Mr. Phillips was selected as judge, and awarded the cup to the Washington Minstrels.

ARE YOU USING IT? THESE MEN ARE. SEE PAGE 49

"It is O. K."—W. C. SUTTON, Bijou Theatre, Xenia, Ohio.

"It is a good idea and seems very complete."—H. W. HEILBERGER, Lehigh Orpheum Theatre, South Baltimore, Pa.

FILMS WILL BOOST "MADE IN AMERICA"

Motion Pictures Expected to Become a Strong Factor in Nation Wide Movement for Booming Industries of the United States—Corporations with an Aggregate Capital of a Hundred Million Pledge Co-operation—Of This \$10,000,000 Represents Photo Play Manufacturers

THE reception accorded the plan to establish a national open-door holiday to be known as Made-in-America Day, to be brought about by a monster publicity campaign which involves the filming of all America, has been a surprise even to the most enthusiastic boosters behind the idea.

With hardly a week devoted to the promulgation of the idea, the response has been so great that the movement is now being placed on a solid footing by the organization of a national executive committee.

Endorsements have come from chambers of commerce, women's organizations, industrial bodies and prominent individuals from all parts of the country. General delight is expressed that at last the preaching of the patriotic American business man, "Patronize American Industry," is to be crystallized into a practical form of expression in the organization of a Made-in-America Day. The co-operation pledged has the ring of spontaneity.

Corporations whose capital aggregates a hundred million dollars have swung into line behind the Made-in-America Day banner bearers. Of this, \$10,000,000 represents capital invested in the motion picture industry.

It is noteworthy that for the first time in their history the motion picture concerns, of whom fully a score have combined forces to further the movement, have put aside all ideas of competition, appreciating the fact that in the realization of a Made-in-America Day their industry, as well as all other established or future forms of American enterprise, will gain to an incalculable extent.

Details of the Movement

In reply to manifold inquiries as to details of the movement, publicity headquarters has issued the following bulletin:

"In view of the spontaneous pledges of support received from thirty nationally-known corporations to date, the movement to secure the establishment of a calendar holiday devoted to furtherance of interest in American-made goods, to be known as Made-in-America Day has been formally launched. These corporations include the Supplee Hardware Syndicate, the United States Lithographing Company, Warner's Features, Inc., the United Film Service, controlling fifty exchanges; Morgan Lithographing Company, United Motion Picture Producers' Association and twenty other motion picture manufacturing companies, publishers, printing firms, mercantile and commercial corporations, with daily accessions to the list being received.

"Earliest efforts of the moving spirits in the Made-in-America Day propaganda have been directed toward securing the support of the above organizations as representing various phases of business life especially helpful in a practical sense in giving the movement its initial impetus.

"For instance, the motion picture firms

which have become affiliated with the movement will share equally the expenses connected with the making of the gigantic film serial, "America," an enterprise which necessitates the sending of an expedition into all parts of the United States and which will be released in weekly sections to all the important motion picture houses throughout the country in furtherance of sentiment for a Made-in-America Day.

"The lithographic firms will contribute thousands of stands of striking posters heralding the coming of the party of boosters which will be part of the filming expedition and will co-operate with local organizations and the newspapers in the respective cities visited in arranging for a concerted expression of the population in favor of a Made-in-America Day.

Weekly Exhibition of Films

"Picture marketing firms and picture exchanges will make arrangements for the weekly showing of the Made-in-America films in the cities where they are located. Financial interests will use their powerful influences in insuring the co-operation of leaders in the business life of the points touched by the campaigners.

"Women's organizations will have a big part in the arrangements, their especial task being the organization of receptions for the Maid of America, as she will be known, the woman to be so advertised, to be chosen by contest for her qualities as a propagandist for the movement.

"At a general meeting of the heads of the New York corporations already pledged to the movement it was agreed to place J. Arthur Nelson, father of the Made-in-America Day movement, in charge of general arrangements. Nelson will accompany the staff of motion picture technicians and

operatives to be sent on the filming tour in a private car, and the films will be made under the joint direction of himself and the Chamber of Commerce interested in exploiting the advantages of the particular territory to be filmed. The Maid of America, to inject a note of human interest, is to appear in these films, supported by a select company of motion picture players, who will be employed in enacting film playlets that will serve to accentuate the particular resources and unique claims to fame of the localities included in the 'filming America' operations."

It is not Mr. Nelson's idea that Made-in-America Day should be set aside as a legal holiday, in the sense that its observance involves the closing of shops and factories and cessation of public business. Mr. Nelson said on this point:

Means for Raising the Money

"Made-in-America Day, as its name suggests, is to be a day for American trade to show itself at its best. Attention is to be attracted to American-made goods by every means open to the ingenuity of the wide-awake advertising man.

"The city government will suspend ordinances prohibitory to street parades, or taxes on such method of advertising, for the benefit of merchants and manufacturers who may want to combine in arranging a trade pageant. Extra special bargain sales, souvenir and free sample distribution and special musical and other entertainment in the department stores would be other forms of attracting notice to American manufactures.

"Made-in-America Day would be the day of inaugural events in fashion show or auto show weeks. There would be special photoplay features exploiting home industries.

Chicago's Mayor Sees "Julius Caesar"

Chief Executive Expresses Keen Interest in Huge Kleine Production Depicting the Life of the Greatest Man in History

Special to MOTION PICTURE NEWS

Chicago, Nov. 11.

MAYOR Carter H. Harrison, of Chicago, and Andrew M. Lawrence, publisher of the Chicago "Examiner," were guests of George Kleine at a private exhibition of Mr. Kleine's big, new six-part spectacle, "Julius Caesar."

The mayor was delighted with the picture and expressed his amazement at the monster scenes. He was particularly impressed with the tremendous climax which occurs at the end of the fifth reel where twenty thousand people, clad as Roman soldiers, Egyptians, Gauls and the representatives of all Rome's captive nations, march before the camera in a single scene.

In actual footage this scene measures 276 feet. Through aisles of cheering, gesticulating people march the costumed thousands ten abreast. The steps, walls and roofs of a score of temples as far as the

camera's eye can reach, present a picture of massed humanity that cannot be easily forgotten.

George Kleine's "Spartacus" was shown Pittsburgh newspaper men at a private exhibition in the New Miles Theatre. C. H. Miles, in association with Marcus Loew and Sullivan-Considine, has opened up the old Pitt Theatre as the New Miles, using vaudeville and pictures.

Jane Addams, of Hull House, Chicago, is one of the many educators who are anxious to see George Kleine's big new multiple, "Julius Caesar." The famous Chicago woman expects to show "Caesar" to the poor children embraced by the charitable work of Hull House, in the very near future.

The magnitude of the spectacle and its strong human interest features make it highly appropriate for children as well as adults.

Motion Picture News

HAS THE QUALITY CIRCULATION OF THE TRADE

MOVING PICTURE NEWS EXHIBITORS' TIMES

Published Every Week by

EXHIBITORS' TIMES, Inc.

220 West 42nd Street, New York City.

TELEPHONE BRYANT 7650

Chicago Office, 233 W. Jackson Boulevard

WILLIAM A. JOHNSTON.....	President
HENRY F. SEWALL.....	Vice-President
E. KENDALL GILLET.....	Secretary
H. ASHTON WYCKOFF.....	Treasurer
WENTWORTH TUCKER.....	Ass't Treasurer.

WILLIAM A. JOHNSTON.....	Editor
LESLEY MASON.....	Managing Editor
WILLIAM RESSMAN ANDREWS.....	News Editor
H. ASHTON WYCKOFF.....	Business Manager
R. M. VANDIVERT.....	Advertising Manager
E. J. HUDSON.....	Circulation Manager
THEODORE S. MEAD.....	Chicago Manager

This publication is owned and published by Exhibitors' Times, incorporated under the laws of the State of New York. The offices and principal place of business are at 220 West 42nd Street, New York City. The address of the officers is the office of the publication.

Entered as Second-Class matter at the New York Post-Office.

Subscription \$2.00 per year, postpaid in the United States, Mexico, Hawaii, Porto Rico and the Philippine Islands. Canada, \$3.00; Foreign \$4.00 per year.

ADVERTISING RATES ON APPLICATION.

Copy for next issue must reach us by Tuesday, 5 p. m.



Cuts and copy are received subject to the approval of the publishers and advertisements are inserted absolutely without condition expressed or implied as to what appears in the text portion of the paper.

Vol. X November 21, 1914 No. 20

Let the Price Rise With the Quality

THE American public habitually has always demanded the best. Fortunately, however, it always has been willing to pay whatever the best costs.

This has been illustrated in so many different lines of business that it seems strange that many exhibitors do not realize how it applies to their business. There are even manufacturers and exchange managers whose view of the situation is equally befogged.

* * *

THE error of these men is that they see only half the truth. Almost to a man they realize that the public demands the best, but not that it will pay for it. Instead of joining the movement which will give the public the best, they sit back and insist "it can't be done."

A few years ago people who went to motion picture shows were satisfied with the mere fact that the pictures "moved." Most of them thought of the films as an amusing toy soon to be cast aside.

Then anyone could wear a smile and say "it can be done," when speaking of giving the public the best.

* * *

SUDDENLY it dawned on manufacturer and public that pictures were not a passing fad, but had become an established provider of entertainment.

As soon as the public understood that the films were to be with them always, they demanded improvement—then and there. The manufacturers were willing enough—they all wanted to boom their business.

Since, quality of motion pictures has increased to an amazing degree. But, inconsistently, the public is still paying practically what it did in the days of the first crude "store-shows."

* * *

THIS is a condition unprecedented, unparalleled in any other industry, except where improvement of product has decreased cost of manufacture.

As everyone knows, the production of the better class films has been attended by tremendous increase in manufacturing costs. This is one of the points most strongly emphasized by Carl Laemmle, president of the Universal Film Company, in his recently inaugurated campaign for higher prices.

Mr. Laemmle urges that exhibitors pay higher rental for their films and charge higher admission prices to cover the difference.

* * *

THIS is the argument which MOTION PICTURE NEWS has advanced for months. It is not a move solely for the benefit of the manufacturers, as it might appear to the undiscerning.

It is something absolutely necessary, if the film industry in all its branches is to be kept healthy, prosperous and constantly moving forward.

* * *

IF better pictures are to be produced, the makers must have more money with which to meet the heavy expenses. The ultimate consumer of motion pictures is the person who pays to see them.

He is now demanding the best, and he is willing to pay for it.

This is the important fact every exhibitor must appreciate. Give your audiences the best you can get, and charge them accordingly.

As soon as the manufacturers see that exhibitors generally are taking this course, they will be glad to spend more on production.

The increase then will not come from the exhibitor, but from the public.

* * *

IT is obvious that admission prices can be raised only when the exhibitors are well organized. If each man is trying to run his theatre regardless of the common good—which means his own permanent good—prices will be kept down and even cut. This is destructive of all progress.

Already numerous examples have been cited in the columns of MOTION PICTURE NEWS of theatre owners who have successfully raised admission prices.

In many cases exhibitors have been led to raise prices through an efficient local organization. The success which has attended such movements can easily be duplicated elsewhere.

By state and national organization along solid lines it can be made even more certain.

* * *

THE one thing necessary is that the exhibitor look to the future.

Organization may mean a small sacrifice of time and money. In the end it is sure to prove an advantage to every manager.

The exhibitor who refuses to ally himself with his companions is only hurting himself in the long run. Why be so short sighted?

Milwaukee Man Predicts Dollar Pictures

Manager Saxe Sure New York Will Not Be Only Place Where Admission Price of This Figure Can Be Obtained—One-Cent Shows for Schools

Special to MOTION PICTURE NEWS

Milwaukee, Wis., Nov. 10. A PROFOUND sensation was created in photoplaydom recently by an interview that Thomas Saxe, head of the Saxe Amusement Company, gave to the local papers, in which he predicted that the time was not far distant when the public would pay one dollar for a photoplay as readily as they now pay \$1.50 for a musical comedy or a dramatic production, and that the dollar photoplay house would not be confined merely to New York, but would soon be in every city.

Though the interview was given primarily to justify the raise in prices at the Alhambra theatre and was a neat bit of press work on Mr. Saxe's part, nevertheless he meant every thing that he said, as he had made the same statement some time previously in a private conversation.

"I am more firmly convinced than ever that the motion picture industry is still in its infancy and its possibilities are just beginning to be realized," said Mr. Saxe. "I am convinced that the photoplay of the near future will be the picture for which the public will pay a dollar without the slightest question.

"Motion picture patrons have been quick to appreciate the better class of pictures which have been shown from time to time at the popular-priced houses and are not willing to accept anything that falls below these standards.

"They demand to see the biggest stars of both the motion picture world and the 'legitimate' stage on the screen. They want big productions lavishly staged and they demand that every detail shall be accurate. The day has gone by when the stage director wrote his own scenario, and when a melodrama of the West filled with cowboys, Indians and bucking bronchos satisfied the public's demand for realism."

On the heels of Mr. Saxe's prediction of the dollar photoplay outside of New York City came the announcement from the school board that the first of photoplay shows at the social centers would be presented that evening and that the admission price would be one cent. These municipal motion pictures are shown under the direction of the social center division of the public schools and are presented in the school houses. They are very well attended, prac-

tically the whole neighborhood turning out for the show, the one cent admission fee proving very attractive.

The local school board is going into the motion picture field very extensively, bids having been asked for three Simplex projectors and complete outfits for use in the schools. The school authorities are meeting with no opposition from the local exhibitors; in fact, the exhibitor rather welcomes this step on the part of the school directors.

Inquiry among the exchange men and exhibitors failed to reveal any antagonism to the one cent pictures. Manager Harry Graham of the Butterfly theatre, voiced the prevailing sentiment when he said of the new educational movement:

"I don't believe that the school board will find any of the exhibitors opposed to the penny films in the schools. As far as being opposition to the theatres, I really believe that they help business, as the schools reach many people who never attend the theatres at present, and they are simply turning out a new crop of film fans. It's certain that no patron will ever be contented with the shows they are putting on, as most of the subjects are old and principally educational and scenic."

Said one of the local exchange men regarding the penny pictures on the schools of Milwaukee:

"Exhibitors need never fear competition from this source as long as the film exchanges control the supply of film. We will always protect our exhibitors and you may rest assured that no real competition will arise from the schools."

FINDS IT INDISPENSABLE
Pekin, Ill.

"Motion Picture News,"
Gentlemen—I have received your sample copies of "Motion Picture News" for which I thank you. I don't see how I got along without it in the past, as I find it one of the best trade journals for the exhibitor.

I am enclosing herewith a check for \$2 to cover a year's subscription in advance.

Yours very truly,
E. C. BOSTICK,
Manager, Bostick Amusement Co.

CRIMMINS IN STRONG KINETO-PHOTE RELEASE

Another actor has about deserted the stage for the film drama in the person of William Crimmins, who is featured as "the Vulture" in the Kinetophote's coming release "The Coming Power," a political story filled with the thrills of a strenuous campaign. "The Coming Power" is Mr. Crimmins' second venture into the feature



WILLIAM CRIMMINS

field in a principal role. Previously he did the heavy comedy lead in "Maria Roma."

On the stage Mr. Crimmins has had a brilliant career. He has been a Belasco player and has played many parts in support of Amelia Bingham, Percy Haswell, George Fawcett, James K. Hackett and others. He was with Edna Goodrich in "Evangeline," and prior to that played with George Beban. Later he had parts in "We Are Seven" and "At Bay."

"LORD FAUNTLEROY" TAKES PLACE OF "MR. PIPP"

"Little Lord Fauntleroy" has been decided upon as the Alco release of November 16. "The Education of Mr. Pipp" which was announced for that date has been postponed until further notice.

STARS OF "THE HOOSIER SCHOOLMASTER" (ALLIANCE-MASTERPIECE) AND SCENES FROM THE PLAY



MAX FIGMAN

THE LOVERS TOGETHER

THE ACCUSATION

LOLITA ROBERTSON

AMONG THE EXCHANGES

DETROIT EXCHANGE MEN AS THEATRE OWNERS

GEORGE WEEKS, manager of the Detroit Universal Film Company, has purchased the Royal Oak Theatre at Royal Oak, Mich., and will make a number of changes that will tend to improve the appearance of that playhouse.

Mr. Weeks now controls the Kercheval Theatre, the Plaza at 2601 Jefferson avenue, the Forest Theatre on Woodward avenue, and the Royal Oak, giving him a total of four in Detroit and vicinity. From time to time he plans to increase the number and hopes before long to have a chain of at least a dozen theatres.

The Royal Oak is under the management of Charles Hyatt; the Plaza under the management of John P. Church; the Kercheval, Grant Deats and the Forest, Rex Minkley. The Royal Oak seats 400; the Kercheval, 400; the Plaza, 800, and the Forest 700 people.

Charles Wesch, treasurer of the Detroit Universal Film Company, is building a theatre on Hamilton Boulevard, Detroit, to be known as the Virginia Park. It is practically completed and the contractors have promised to have it all finished and ready to open by November 25. According to Mr. Wesch, it will be "one of the prettiest playhouses in the city."

LEWIS WILL MANAGE NEW YORK K. C. EXCHANGE

CHARLES LEWIS, who virtually has grown up in the film business, has been engaged to manage the New York exchange of the K. C. Booking Company, Incorporated. Mr. Lewis is well known in local film circles through his association with the Universal and with the Jungle Film Company, which exploited the Paul Rainey pictures.

The K. C. Booking Company, Incorporated, has taken over the bookings of "Born Again," in which Beulah Poynter has been featured. This film will now be handled through the K. C. offices, its branches and affiliated exchanges throughout the country.

The picture will take the place of "The Little Jewess," a Kinetophote production, in the November releases. "The Little Jewess" will be set forward to the December list of Kinetophote releases. Theatres which have booked it for November will have the picture on dates in the following month.

SCHMIDT ENTERTAINS EXCHANGE MEN AT PALO ALTO

MONDAY, October 26, twenty-one, San Francisco film exchange men journeyed to Palo Alto, where they were the guests of H. C. Schmidt, and attended the opening of his new theatre, The

Marquee, a \$20,000 house with a seating capacity of approximately 500.

The opening bill was "Vendetta," a Kleine production, shown for three nights at a general admission price of twenty-five cents. This was followed by "The Spoilers" for four nights at thirty-five and fifty cents.

Following the opening performances at the new theatre a banquet was served by Mr. Schmidt to his guests, the exchange men, and a number of local people.

DAVIE WILL HANDLE ALCO FOR MICHIGAN

CHARLES M. DAVIE has tendered his resignation as general manager of the Wolverine Feature Film Company, Campau building, Detroit, and about the middle of this month will open an office in the same building as Michigan agent for the Alco feature films. He will have entire Michigan rights to all Alco productions.

Mr. Davie will continue as a member of the Wolverine company, and will aid in its management as much as he can.

"I believe the Alco is just as good as any feature concern doing business to-day, and inside of three months I hope to be booking in the neighborhood of from 50 to 75 theatres," he said. Mr. Davie has secured a franchise for five years covering Michigan. Among the first theatres to contract for Alco service was the New Empire on Woodward avenue, which will use a new feature every Monday.

DEMAND FOR FEATURES RISING SAYS EMMICK

ACCORDING to E. H. Emmick, manager of the Alco and Golden Gate exchanges, Los Angeles, there is a greater demand for multiple reel features at the present time than ever before. The two exchanges are swamped with inquiries, and every day there are many exhibitors who personally call to make selections.

"This is the fourth year I have been in the film renting business in Los Angeles and the demand has gradually grown greater each year until now it is all we can take care of even with a force twice as large as we had at this time last year," Mr. Emmick said.

ARE YOU USING IT? THESE MEN ARE. SEE PAGE 49

"I consider it a very good plan."—J. H. FARRINGTON, The Colonial Theatre, Saranac Lake, N. Y.

"The idea is a good one."—WM. H. MACK, Endwell Theatre, Lestershire, N. Y.

ROSENBERG LEAVES GOLDEN GATE

MIKE ROSENBERG, who has been manager of the All-Star Attractions department of the Golden Gate Film Exchange, in Los Angeles, for the past six months, left the latter part of this week for Minneapolis, having purchased States rights for "The Spoilers" for Minnesota, North and South Dakota and Montana.

The Golden Gate Film Exchanges have secured the rights for all future showing of "Cabiria" in the west coast states—California, Washington and Oregon. The picture was shown for the fourth week at the Trinity Auditorium, Los Angeles, to excellent business.

ALCO OPENS EXCHANGE IN KANSAS CITY

THE Alco Film Service of Missouri, 317 Floyd Building, Kansas City, Missouri, under the management of William Sievers, is the eighteenth in the growing list of Alco exchanges. As with all the other exchanges, the Alco Film Service of Missouri have constantly available big features which Alco is putting out.

The Radium Gold Fibre Screen, the product of the Atsco branch of the releasing corporation, and all projection and theatre supplies will be available to the exhibitors of the territory served by this newest exchange.

CASINO AND DULUTH EXCHANGES CLASH IN COURT

BECAUSE of legal complications between the Zenith Feature Film Company, of Duluth, Minn., and the Casino Feature Film Company, of Detroit, a packed house at the Grand Theatre, Menominee, Mich., was disappointed on October 29, when the "Paid in Full" films were replevined under instructions from the Detroit company. The Casino Company claimed that the Duluth concern had no right to book the film in Michigan as they had the State rights.

ACME HEAD RETURNS TO DETROIT

F. JACOBS, of the Acme Feature Film Company, Detroit, returned November 4 from a business trip to New York City. The Acme company was organized some weeks ago and started in business shortly after October 1. It has offices at 215-216 Moffat building.

DICKESON LEAVES WORLD

DOUGLAS DICKESON, formerly manager of the Detroit office of the World Film Corporation, who resigned some weeks ago, is now salesman for the Mutual Film Corporation in this city.

Bosworth Stars a Talented Couple

Phillips Smalley and His Wife Bring Rare Qualifications to Their Work in the Productions of the Company

THE Smalleys, who recently associated themselves with Bosworth, Inc., have been turning out some remarkable films. One of these, "The Traitors," has been pronounced by many authorities to be the most talented single reel that has ever been filmed, and it bears the distinction of having been the only one-reel film that has ever been featured in electric signs at the Strand Theatre, New York.

Rarely, if ever, has it been given to one couple to combine the unusual talents and remarkable qualifications represented in Mr. and Mrs. Phillips Smalley (Lois Weber, author and director of the "Hypocrites"), who are now associated with Bosworth, Inc., as authors, artists and directors.

Mr. Smalley is the son of George W. Smalley, the noted war correspondent of the "New York Tribune," under Horace Greeley, who was later sent to London to represent the "Tribune." Phoebe Garnet, a great-grand-niece of Lafayette, adopted



LOIS WEBER

by Wendell Phillips, met her future husband, who during the period prior to the Civil War was body-guard-in-chief to the great abolitionist.

At the close of the war, Phillips Smalley, with his mother and father, went to Europe, and was later, with his father, locked up in the siege of Paris. Phillips Smalley, on returning to England, was sent to Balliol College, Oxford; while his mother established a salon that for notables of the past generation stands almost without a peer. This salon, now a matter of history, had for constant habitués such notables as Gladstone, Disraeli, Salisbury, Roseberry, Huxley, Tyndall, Browning, Whistler, Alma Tadema, Watts, du Maurier, Swinburne, Oscar Wilde, Sir Henry Irving, Ellen Terry, the Bancrofts, Beerbohm Tree, Mrs. Woods, and the whole interesting family of Robertsons, known for their talent and culture.

Sir Henry Irving's dressing-room at the Lyceum Theatre was Mr. Smalley's "second home." For a period of at least 20 years he did not miss a single "first night" at the Lyceum. The scenery for Sir Henry's production "Coriolanus," designed by Tadema, was architecturally laid out by Mr. Smalley during the time that he was a student in water color under Tadema himself. As an artistic incident of Mr.

Smalley's career he posed for George du Maurier, the artist and novelist, during a period covering fifteen years.

Mr. Smalley was an intimate friend of the present King when he was Prince George, and the two, together with Prince Herbert Bismarck, had many larks together as youths. His leanings from his earliest days were toward the stage, and he shared this with Lois Weber—herself



PHILLIPS SMALLEY

a product of America—born and reared first in Pittsburgh. Miss Weber was a concert pianist at sixteen; joined the Church Army Workers in an earnest effort to help the poor of Pittsburgh. Then, possessed of a voice of more than usual brilliancy, she exchanged book and organ for orchestra and opera score.

It was while playing the leading role in "Why Girls Leave Home" that Miss Weber became engaged to the manager of the company, Phillips Smalley. She and Mr. Smalley have been congenial co-workers during the nine years of their married life; their present work with Bosworth, Inc., giving free scope to their remarkable versatility and ability, gives rise to the conviction that "The Smalleys" will in the near future turn out even more wonderful productions than the "Hypocrites," and similar releases, unapproachable as that production seems at the present time to be in all respects.

WAR CHARITY PERFORMANCES IN NEW YORK THEATRES

The Motion Picture Exhibitors' Association of Greater New York, comprising almost every motion picture theatre in the city, in conjunction with the War Children's Christmas Fund, of which Mrs. John Hays Hammond is national chairman, and Mary Garret Hay is secretary, will give special performances in the various theatres of New York to assist in the collection of gifts for the war-stricken children of Europe.

NEW FIRM LAUNCHES REPORT SERVICE

THE much talked-of company of Morrison and Poppe, whose operations have been kept secret for the past month, causing considerable curiosity throughout the trade, has come forward with their announcement. MOTION PICTURE NEWS is the first to print the news and give the trade a complete description of their plan whereby exhibitors will be advised of the value of all feature films before they are released and fully posted as to the character and merits of each production before it is booked into the theatres.

The idea is one which has crept into the minds of many of the business' most wide-awake men, but one which has never before been put into practical use. The plan is to furnish reports on the quality of feature films to guide the exhibitors in booking.

Mr. Morrison, when seen at his office in the Times building, had this to say:

"The idea came to me over and over again when I was engaged in booking regular service to exhibitors in Chicago and vicinity. Later, when I was running a feature exchange and seeing ten or more exhibitors daily, I took advantage of the opportunity of asking them what they thought of it, and it met with their universal approval.

"The plan is very simple. Mr. Poppe and I see all feature films; that is, the outside features and the features in the regular one-reel programs which are rented at an extra price, before they are released. Arrangements have been made with practically every manufacturer and importer to view these films at the offices of the latter. Reports are then written up and kept on file and are also mailed to exhibitors who subscribe to the service each week so that the subscriber will at all times be posted as to the merits and character of every feature on the market.

"The reports are not written in the form of a review. No attempt is made to please the eye or ear or the literary taste of any subscriber. They are written in as few words as possible and tell plainly whether a picture is good, passable or bad, and name the varying degrees of merit to which pictures are heir. A clear, concise statement is included with each report as to the class of audience the picture is best suited to.

"The reports are typewritten affairs, written personally by either Mr. Poppe or myself, and are made out on uniform size sheets, punched to fit a loose-leaf file which we furnish subscribers.

"Mr. Poppe, like myself, is thoroughly familiar with the game; in fact was reviewing pictures for one of the trade papers many years ago when the Patents Company and Independents were waging war on each other and features were unheard of. He has been in the theatrical business, in the theatre end, ever since he left the publication end, and is in close touch with the exhibitor in many parts of the country."

Mr. Poppe had this to say: "What Mr. Morrison has said thoroughly outlines our company's operation, but I might add that our plan is antagonistic to none of the existing members of the Motion Picture fraternity of interests."

PATHE HAS BIG PLANS FOR AMERICAN FIRM

Jersey City Studios Will Be Placed at the Disposal of Any Producer Whose Ideas Are Acceptable—Plan Insures Certainty of Profit from Productions Made on This Basis—One Picture a Week Too Rapid and Ruinous a Method, He Believes

CHARLES PATHE, who came to this country last spring and made important changes in the affairs of the American Pathe Company, is now here again—with this difference—that he will remain, according to his own statement, for a number of months or a year, or perhaps even longer.

At any rate, it is quite evident that Mr. Pathe has come to carry to a successful issue the plan he had in mind last spring, namely, to put the American branch of Pathe Freres upon the same basis as the European house. This plan briefly means that his producing business will be conducted henceforth upon practically the very same basis as the book publishing business.

Said Mr. Pathe: "It is my desire to gather around me here, in the same manner as I have done in Europe, a number of the most intelligent producers in America who will be stimulated to make the best pictures and earn the most money."

Studio Available for All

To every prospective purchaser whose ideas of production are acceptable to Mr. Pathe he will offer all his many and excellent facilities of studio and factory production, and of film distribution. He will see all such applicants personally and lend his personal services to their work. He will also inspect all negatives that are offered to his company.

"My scheme," said Mr. Pathe, "is a simple one; it is as a matter of fact nothing more, nothing less than that which exists in regard to the stage and the publishing business, with this difference, that instead of giving the producer of film a disputable and uncertain percentage of the profits arising from his production, he will receive from us exactly 50 per cent. of the net profits from his film.

"The receipts from such productions in the way I offer will satisfy the reputation and the interests of the most ambitious film producer in the world."

In this connection, Mr. Pathe cites the profits made through this scheme by the celebrated comedian, Max Linder. As an employee only with Pathe Freres, Mr. Linder earned about \$8,000 a year. His earnings under the new scheme are ten times that amount, or \$80,000 a year.

Topicals Will Form Programs

Mr. Pathe believes that the program in the near future will consist solely of features combined with such topical or news films as the *Pathe News*.

The complete program, in his estimation, is suitable for the small theatre at the present time, but in his estimation even these theatres will change eventually to features.

"Is it your intention to supply the exhibitor with a complete service?" Mr. Pathe was asked.

"We shall undoubtedly be able to do that," said Mr. Pathe, "and very shortly; that is to say, our productions will be sufficiently varied and of a sufficient number

so that the exhibitor can make a selection from them for his program without relying upon any other source. However, it is not our desire to tie them down to an exclusive service. I am stoutly opposed to this idea.

Quality Not Quantity the Rule

"Furthermore, our emphatic policy will be the production of *quality* and not quantity. Producers who heretofore had made it a rule to produce a theme every week will soon learn that their idea is as false as the idea of the dramatic author who tries to produce a half a dozen plays for the theatre in a year.

"Three or four films in such a period properly studied, first from the point of the scenario and then carefully handled and executed, such is the policy that must be followed in the future by the producers who wish to earn money.

"At present," continued Mr. Pathe, "we

are already producing twelve to fifteen reels a week. We shall of course extend the number of these, but our policy first and last is quality production. Our new scheme will enable us to broaden the gage—the variety of our productions.

"The European studios of Pathe Freres are still producing, but of course on a limited scale."

The English market, Mr. Pathe said, is as good as ever. Shipping facilities alone are at fault. Business is also normal in Russia, Spain, Italy and some sections of France. In fact, it is only in the war area at present that the theatre business is affected, and there it has completely ceased. As a matter of sentiment, no comedies are being turned out at present in the Pathe studios in France.

All of the new Pathe productions will be distributed as at present through the Eclectic exchanges.

New Brands Added to Kriterion Program

Mica Company Plans to Market the Paragon, Thistle, Monarch, Navajo, Robin, Santa Barbara, Alhambra and Kriterion Star

EXHIBITORS who have been following the advertising announcements of the new Kriterion Program will be interested in the following announcement given out at the temporary headquarters of the Mica Film Company, 220 West Forty-second street, New York.

About December 1 this company will make its headquarters at 1600 Broadway, where an arrangement has been made with E. V. B. Von Brandenburg, of the Gibraltar Films Corporation.

The Kriterion program will consist of the following brands: Paragon, Thistle, Monarch, Navajo, Robin, Santa Barbara, Alhambra, Kriterion Star and two others, the names of which will be announced later. There will be twenty-one releases a week.

In each will be included six comedies and six dramas. The first release date has been set for Friday, January 1. The Crown City Film Manufacturing Company, of Los Angeles and Pasadena, will produce the Thistle and Paragon brands which will consist of one comedy and one drama each week.

Donald McDonald will be in charge of productions together with Bruce Mitchell and Arthur H. Coldewey. Prominent stars in the comedies will be Rena Rodgers, Ralph McComas and Allen Fralick. Dorothy Davenport will be the lead in the dramatic productions, supported by Joseph Singelton and Ed. Alexander.

The Santa Barbara Company will produce a comedy and a drama each week with A. M. McKennedy, general manager, in full charge of productions. The dramas with Fritzie Brunette as the lead will be directed by William Robert Daly and Bert Angeles will direct the comedies.

Two comedies a week will be produced. The other companies are the Robin Photoplay, Inc., with Jesse Robin as general

manager and director, and J. L. Philips and Margaret Ruby as stars; the Navajo Film Manufacturing Company, of Los Angeles, Charles K. French, general manager, and an old well-known cast producing western dramas; the Monarch Producing Company, Los Angeles, Harry Harvey managing director, formerly with the Nestor and Solax companies.

The Alhambra Film Manufacturing Company's announcement of stars and casts will follow shortly.

The office of the Mica Film Company will also be announced later. Exchanges already exist throughout the United States. These consist of twenty-nine distributing offices, along with which are included twenty main centres. The distributing idea is to give the exhibitor the quickest possible service, together with the cheapest possible shipping rates.

A number of the above companies have been producing for some time, but none of their former productions will be used.

COLONIAL ADDS TOPICALS TO ITS PRODUCTIONS

The Colonial Motion Picture Corporation has entered the topical field by securing the exclusive rights for photographing in motion pictures the annual Yale-Harvard football game on November 21 at New Haven.

VEILLER PLAYS TO BE SEEN ON THE SCREEN

Bayard Veiller, author of "Within the Law," "The Fight" and other plays, has signed a contract with the George W. Lederer Filmotions Corporation for the screen production of the latter play. A strong company has been assembled.

"THE COUNTRY MOUSE"

(Bosworth—Paramount)

REVIEWED BY H. S. FULD

THE present-day exhibitor has much to be thankful for. With one feature after another, each on a par with the others, and all of them good, he is at a loss to pick out a program. And now comes Bosworth with another crackerjack release in "The Country Mouse."

Hobart Bosworth, the inimitable, gives a fine exhibition of his ability in his portrayal of an incorruptible congressman; and his wonderful physique is shown to good advantage when he dresses in evening clothes.

In this production he is supported by an exceptionally well-chosen cast, and even the characters in the minor parts are thoroughly alive to their respective roles.

Billy Balderson (Hobart Bosworth) is elected to the legislature, and taking his wife, the "country mouse" (Adele Farrington), with him, moves to the capital. About to be drawn into the clutches of the lobbyists, George and Myrtle Marshall (Marshall and Myrtle Stedman), Balderson proves himself proof against temptation where politics are concerned.

But the wiles of Mrs. Marshall are fast making him forget his wife Addie, and he spends most of his spare time with the former. Addie overhearing two female gossips referring to her as



"SHE CAN TANGO!"

"a little country mouse, a poor little frump with no spirit," makes up her mind to meet Mrs. Marshall on her own ground.

With a blank signed check from her husband she enlists the services of Mme. Pauline, proprietor of a beauty parlor, and the result is such a complete transformation that she can hardly believe her eyes.

Passing Billy on the street he does not recognize her, but something about her appearance makes him say to himself: "My little country mouse might look like that if—"

An invitation to a ball and reception being accepted, Billy leaves his wife at home and goes alone. Quickly the transformation is once again gone over, and the country mouse appears in the ballroom as a wonderfully charming and brilliant woman. Marshall being among those present, quickly seizes his opportunity to persuade Addie to influence Billy's vote, and Billy finding them together in what looks to him a compromising attitude, is furiously jealous.

The denouement is cleverly turned to a comedy finish, and the picture closes happily, with Addie teaching her hubby the latest tango dances.

The entire production is so interesting throughout that one is hardly conscious that it has taken four reels to tell the story. There is not a dull moment in it, and good clean comedy is there in copious quantities. It should add to the producers' reputation.

STEINER LEAVES ON TRIP TO COAST

William Steiner, of the Photo Drama Company, is off on a trip to cover the territory and offices that are handling "After the Ball." Two companies opened last Monday in Canada, one

at the Grand Opera House in London, Ont., and the other at the Grand Opera House in Toronto.

Mr. Steiner will cover the coast country before he returns because the demand for bookings on "After the Ball" is so great.

"THE QUEST OF THE SACRED GEM"

(Pathe—Four Reels)

REVIEWED BY CLIFFORD H. PANGBURN

THE fine acting and photography and the effective settings of this attractive picture offer a striking example of the good work which is being done in American studios at the present time. A number of the scenes are laid in Indian temples, but so carefully have they been arranged that they have every appearance of having been taken in the Far East.

The views in the temple from which the diamond was stolen are of particular excellence. A great open hall, apparently built of massive materials and in correct oriental architecture is seen. At the far end of it is an idol in the form of a grotesque elephant seated upon a throne.

A crowd of native worshippers are bowing before the image. The theft of the diamond from the idol's forehead is accomplished by an American disguised as a native. The priests are aroused, and a short but exciting fight takes place. All of this is shown in the dim light of the moon, which shines through a few high windows.

It is an exceptionally fine piece of photographic work, and its effectiveness is further enhanced by the attention to details. For example, a Hindu priest with a withered arm is the one who gives the alarm.

When the action of the story is transferred to the United States the scenic effects are even better. A beautiful country estate is utilized, and the interiors are fully in keeping with what one would expect from the outside of the house. Later a fight on the housetops in New York's East Side shows Brooklyn Bridge and the East River as a background. All of this adds to the force of the story, which is full of interest.

The cast is well balanced and includes some capable players. Edna Mayo is seen in the principal feminine role, which she handles in an attractive fashion. Charles Arling appears as the soldier of fortune who stole the diamond. Ernest Truex, as the office boy, adds some good touches of comedy. William Roswell is seen as the fiance of the girl who inherits the wonderful jewel.

One rather startling scene shows one of the Hindu avengers of the desecrated idol hanging by a rope from the roof of a moving Pullman car. Opening the window, he stabs the thief to death, but is knocked to the ground by a telegraph pole before he can get the diamond.

The American soldier of fortune took the jewel from a temple in India. He met his death as mentioned above at the hands of the natives who had followed him. The diamond then went to his



ON THE TRAIL OF THE DIAMOND

niece. Her fiance apparently stole it from here, with the result that the engagement was broken. The mystery is finally solved by a detective, the diamond goes back to India, and the young couple are happily reunited.

As a business getter the film is one of unusual merit in every way, and should please any audience.

SOME OF THE SPECTACULAR SCENES IN KLEINE'S BIG MULTIPLE, "JULIUS CAESAR"



THE CROSSING OF THE RUBICON

THE IDES OF MARCH

THE CONQUEROR OF GAUL

"JULIUS CAESAR"

(George Kleine—Six Reels)

REVIEWED BY H. S. FULD

THOUGH much has been said, and more has been advocated both for and against the long feature—meaning those of four reels and over—nevertheless one is hard put to find any argument or reason that would class this release as too long.

"Julius Caesar" takes about six thousand feet of beautifully tinted film in the telling. There is not a dull moment throughout the story, and the producers have gone to great lengths to make it historically correct. Once started, the film holds one in a grip of tense interest that never relaxes until the final scene.

Beginning with Caesar's courtship and secret marriage to Cornelia, daughter of Lucius Cinna, we are gradually shown the main events of Caesar's life in the order of their occurrence, ending with Caesar's assassination, Mark Antony's speech, and the caption: "Mischief, thou art afoot—take thou what course thou wilt."

Too much cannot be said of the perfectly obvious, painstaking care that the producers have taken to make the different scenes appear true to the atmosphere of the time. The settings for the interiors, the senate chambers, the rooms in the different abiding places of the characters, the tents on the battle fields; all of them appear "real."

If one takes into consideration the magnitude of a production of this kind, it occasions no small matter of wonderment that the scenes "go over" with such smoothness and celerity.

"Painstaking care" does not go half far enough in expressing the careful attention to the most minute detail; the number of rehearsals that must have been necessary in the large ensemble scenes; nor does the expression "real" go far enough in describing the depiction of the Senate chambers.

But mere words have their limitations, and much must be left to the imagination. This production really beggars description, in that a superfluity of praise cannot be given it, nor can an adequate amount of credit, congratulation or appreciation be showered on the directors and producers.

To describe the most interesting scenes would necessitate a detailed account of several. The assembling of the Gallic clans under Vercingetorix to oppose the advance of Caesar, the realistic fight between them and the Roman legions, the capture of Vercingetorix, Caesar's decision to cross the Rubicon, the robbery of the temple of Saturn, the battle between the forces of Caesar and Pompeii, Caesar's magnificent triumphal march through the streets of Rome with the spoils and captives of his many conquests, the assassination of Caesar in the Senate chamber, Mark Antony's oration in the market place, the riot and pandemonium that follows, and the burning of Rome all deserve detailed description. All are examples of wonderful production.

This production will go far to help the cause of the silent drama in its struggle with the house of the "legit." It is a "42 cm." gun, so to speak.

The exteriors, the marching armies of Pompey, of Caesar, of the Gauls under Vercingetorix; the populace waiting in Rome for word of the battle the welcoming of the returning conquerors, when thousands of frantically gesticulating people are in view at one time; these are beyond description.

When one takes into consideration that "Quo Vadis?", "Last

Days of Pompeii" and "Cleopatra" are products of this same company, and that "Julius Caesar" goes them all one better, it is then not hard to realize that powers of description are limited.

The acting of the cast portraying the different characters in this production is beyond criticism. One or two could be singled out and special credit given them, but the entire ensemble is so good that it would be hardly fair to them. Anthony Novelli plays the role of Caesar, and does so in his inimitable manner.

This picture should add to the producer's reputation.

"ONE OF MILLIONS"

(Dyreda-World—Four Reels)

REVIEWED BY PETER MILNE

A TITLE running after the main title of this picture informs us that the film is "A silent drama of protest dealing with the World War." It does not add that it deals with it in a way that will give offense to none of the nations now taking part in the European conflict. This the picture tells us, it takes no particular part whatsoever, which is a large point in its favor.

If there is anyone living who does not realize the horrors of war, this film will straightway give him a correct idea of them, and he will realize the trials and tribulations that many on the other side of the water are now experiencing. In fact the picture makes an urgent appeal for peace, and should be speedily endorsed by all sane persons.

J. Searle Dawley produced the picture, and has presented us with an offering that bears the marks of his wide experience in the field. One fault might be found with it; that is, the characters are not well enough introduced to command the greatest interest at the start, but this fault disappears entirely as the picture passes the half way mark.

Laura Sawyer plays the leading feminine part, the wife of a soldier. Maximilian Jurgens is the soldier who loses his life in battle.

At the outset of the picture the scene shown is a curtain hanging at the top of some steps. From under this curtain runs a stream of dark blood; it trickles down the steps and spells "War." The curtain rises and the story starts. The young soldier is married and an hour afterwards is called to war. It is reported that he is killed in a battle nearby. His mother and wife go in search of him and find him—dead.

His wife is so shocked that her mind is unbalanced. His mother, determined upon revenge, takes it when the rival leader makes his headquarters at her home. She poisons him, then sets the house on fire, and then the scenes fade out.

AMES WITH ALLIANCE

THE Alliance Films Corporation announces the employment of George T. Ames as general director of agencies.

Mr. Ames started his film career in the rewinding room of the General Film Company, with which he was connected for two years. He then became associated with Ward's Exchange, booking features. From there he became identified with Kleine's Exchange, and later with the Weiss Exchange in the same capacity. Mr. Ames continued to make rapid strides in advancement until he became assistant manager of the Mutual exchanges.

"FOR HOME AND COUNTRY"

(Cosmofotofilm—Two Reels)

REVIEWED BY PETER MILNE

OWING to the great success of "England's Menace" and "England Expects—" the two patriotic productions already seen in this country, which were made by the London Film Company, it seems reasonably sure to predict that "For Home and Country" will meet with even greater success, as it is really a better picture.

It concerns war, but is so skillfully handled as to give no offense to the sympathizer of the powers now in conflict. What the picture accomplishes, converting a peace-loving minister to the sword, while not exactly in accordance with the ideals of religious and peace-loving souls, is very cleverly done, so well that it is excusable and not at all repellent.

Scenes of troops departing for the war have been so well scattered in with those scenes in which the principals appear that the



THE DOCUMENT IS DISCOVERED

result is a drama that possesses remarkable unity and coherence. These war scenes are slightly inferior to the others as regards photography, but the fact that they are actual scenes from the front will eclipse this small fault.

Great attention has been paid to the details of the picture, although when the director has secured details that are out of the ordinary he has not called undue attention to them. The scene through the lighthouse window is one of those deserving mention. A row of twinkling lights may be seen, ostensibly shining from the invading fleet of battleships. Again when the spy is shot from the inside of the tent, the hole the bullet made in the canvas may be seen. Small yet important details such as these will materially aid the good effect that the picture will create.

Another very beautiful scene is that in which the home country's ships are to be seen in the harbor, as the sun is setting. In fact the picture is full of artistic scenes, as well as the ones in which detail is attended to.

At the outset of the story we see the minister and his daughter living peacefully. The daughter is loved by a member of the militia, but the father refuses to consent to the marriage owing to his distaste for any military man. But when war breaks out, and he sees helpless persons being mistreated by the enemy, the minister's aspect changes. He even enters the ranks himself, and after the war is over readily consents to his daughter's wishes.

ROBERT H. COCHRANE, JR., COMES TO TOWN

ROBERT H. COCHRANE, secretary and treasurer of the Universal Film Manufacturing Company, has enjoyed for some time sole possession of the name Robert H., but the latest authorized report is that he has a rival for that distinction.

Robert H. Cochrane, Jr., is the name of the "party of the second part," and it is said that he is roundfaced and handsome. Robert H., Jr., came to town October 10, bringing with him a world of happiness for the parents and hearty congratulations from a host of friends.

Along with its ability to report "mother and child doing fine," MOTION PICTURE NEWS offers its unbounded congratulations to Mr. and Mrs. Cochrane.

MIGNON ANDERSON IN HAIR-RAISING AUTO RIDE

MIGNON ANDERSON and Morris Foster, of the Than-houser company, are willing to risk their lives any time. That is probably the reason they accepted Nolan Gane's invitation to try out his new automobile. They did. They also tried a steep hill, two stone fences, a milk wagon and a Stamford trolley car, in quick succession.

Fortunately for all concerned the trolley car was firm on its feet, or rather its wheels. Gane quite unconcernedly backed his car out of the trouble, followed for some distance by an irate train crew and a most loquacious wagon driver. Miss Anderson and Mr. Foster were finally landed (thanks to a kind Providence) at the studio. No, they didn't thank him for the ride!

"LIFE'S SHOP WINDOW"

(Box Office—Five Reels)

REVIEWED BY PETER MILNE

AFTER witnessing sensational productions which profess to be true to life, and then seeing this, it comes as a welcome calm after a storm. This picture is more human and real than any we have seen for some time, and therein lies its merit, as a crowded New York house testified at its termination.

The picture is adapted from the novel which was written by Victoria Cross, and in its adaptation there must have been plenty of opportunities to give the picture a morbid and detestable character, but thanks to the competency of the director those opportunities have been entirely avoided. The production is a clean one, and anyone who has the good fortune to witness it will be glad he has done so.

Leading the cast is Claire Whitney, the central figure of the story. Little is left to be desired in Miss Whitney's characterization of her part. She plays it well and in the right manner. Stuart Holmes plays opposite Miss Whitney. His part is that of a real man, by no means perfect, but unvaryingly sincere. The rest of the cast is well chosen, and go through their parts unusually well.

Some may be so far mistaken as to believe that a story that is in accordance with the ways of real people is uninteresting, but they will find they are much mistaken after witnessing this picture. It is interesting and it is real, the successful combination which is not often attained.



WELCOMING THE NEW ARRIVAL

The scenes have been very appropriately chosen, and are supported by fine photography. The interiors are realistic, none of them ever being so elaborate as to detract from the attention that the characters deserve.

The events that lead up to the clandestine marriage of a servant in the house of an English countryman to a well-to-do boarder, who is learning the art of farming, consume the first part of the picture. Then he departs to make a home for her in America.

Shortly afterwards, the girl gives birth to a child, and her employer not believing that she ever married drives her from his house. She goes to America and lives happily with her husband until an old acquaintance from England appears. His stories and his experiences attract her and she consents to leave the place with him. How she returns because of her child forms a very pretty finale.

"THE BARGAIN"(Ince-Paramount—Five Reels)
REVIEWED BY PETER MILNE

AMONG the present-day directors and script writers of westerns, Thomas H. Ince, aided by William H. Clifford, has a very small number of equals. Whenever we hear the name of Ince it is involuntarily linked with the best of western dramas and melodramas. His wide experience and the wonderful equipment that the forces at Inceville offer are perhaps the best. So that his honors in producing this variety of pictures are well earned.

In "The Bargain" Mr. Ince and Mr. Clifford have produced a wonderfully strong western, which in its own particular class is very good. It contains a typical western story, full of fast, thrilling action, some of which is most sensational. One scene in particular warrants special mention. William S. Hart, who plays the leading part, and his horse, which most certainly must be a trick animal, roll over and over down a steep embankment.

This act in itself is most wonderful, but it seems almost miraculous when we learn that neither of them was seriously injured. Mr. Hart, who plays the part of Bill Stokes, "The Two-Gun Man," is constantly exhibiting his prowess in the saddle throughout the picture. The times when he is not astride his horse he is exhibiting his ability as an actor, and altogether gives an excellent account of himself.

J. Frank Burke is cast as the sheriff, Clara Williams as the girl, J. Barney Sherry as her father, and James Dawley appears in the small part of the traveling minister. Photographically the picture is excellent. Some remarkably extensive scenes have been obtained, and the film is clear in all parts. As the picture was taken in the Grand Canyon of Arizona, scenes have been obtained which are not at all familiar, which give the picture an air of decided freshness.

The experiences and hair-breadth escapes of Stokes, the Two-Gun Man, consume the major portion of the picture. Once he poses as an honest man and wins the heart of the daughter of a miner. Then he has to flee for his life. Finally he is caught on the Mexican border, just as he is about to reform and send the money he robbed the mail of back to the government.



THE HOLDUP IN THE FOREST

The sheriff locks him in a room, then repairs to the gambling hall, where he proves he is not such a competent sheriff after all, by losing all the money. He bargains with his prisoner that if he will get the money back for him he will give him his freedom. This the bandit does in a very clever manner. He returns for his bride, explains matters and the two set off for Mexico to live straight.

KLEINE TO RELEASE "MME. DUBARRY"

George Kleine announces the early release of "Mme. Dubarry," featuring Mrs. Leslie Carter in the title role. In addition to the work of Mrs. Carter, King Louis XV, of France, is played by Richard Thornton; De Cosse, Briçac, Captain of the Guards, by Hamilton Revelle, while Campbell Gollan handles the difficult role of Comte Jean DuBarry. This is the same cast which presented "DuBarry" throughout America.

"THE COMING POWER"(Kinetophone—Four Reels)
REVIEWED BY H. S. FULD

A POWERFUL representation of the suppression of corruption in politics, well acted, carefully staged, and holding one's attention throughout, thereby being just what is needed by the present-day exhibitor.

Frank Norman (Lionel Adams), gaining fame and the nomination for Governor through the inspired writings of Ruth Ellis (Edith Luckett), a crippled girl, is approached by a financier, John Carter (William Crimmins), known as "the vulture."



"THE VULTURE" BUYS POLITICAL FAVOR

Norman being above bribery, several ruses are resorted to in order to compromise him, Miron Mendell, a cat's-paw of Carter's being the go-between. Vera (Anna Rose), the daughter of Mendell, has met and fallen in love with Frank.

Failing in her attempt to bribe him, and stung by Frank's contempt of her, the girl's better nature is aroused. She warns him of the attempts of the plotters, thus becoming the friend of both Ruth and Norman.

Carter, furious at being balked in his designs, plans a frame-up which will land Norman in jail and disqualify him for election. The plot succeeds. Norman is accused of the murder of a gangster, and though realizing he is in the power of "the vulture," Frank cannot help himself.

Resorting to strategy, Vera succeeds in getting a confession from the gangster, who proves to have been only slightly wounded, though rendered unconscious by a blow.

Norman is released, and his enemies are all placed in jail after his triumph at the election. Ruth, dying, places Frank's hand in Vera's, and everything comes out all right.

One of the closing scenes of this release is worth special mention. A wonderful vision appears to Ruth when she is dying, in which she sees Justice helping the workingman and bringing Truth and Honesty together in politics.

The dissolving view where the workingman's chains are struck off by Justice is beautifully executed, and too much credit cannot be given the director.

The story is by Raymond C. Hill, and Catherine Carr pictured it.

HENDERSON, NEW IMP DIRECTOR, COMES FROM THANHOUSER

Lucius Henderson, the new Imp director, has had a wide and varied theatrical experience.

When Mr. Thanhouser formed his first company eight years ago, he selected Mr. Henderson as his second director. Mr. Henderson worked under Mr. Thanhouser at the New Rochelle studios until the company was taken over by the present regime. Mr. Hite, of the new Thanhouser company, transferred Mr. Henderson out to Los Angeles, where he produced, "Cymbeline" and "Carmen." Following this, Mr. Henderson was given control of the Majestic company, where he occupied the position of managing producer.

"THE MAN FROM HOME"

(Lasky—Five Reels)

REVIEWED BY PETER MILNE

THE Lasky company will be obliged to aim at and attain an exceptionally high goal if it intends to surpass the almost unequaled merit of "The Man from Home" in the future. It has not been our pleasure to view all of this company's productions, but of all that we have seen this is by all odds the best.

The photography is up to the usual standard, the scenes and sets are magnificent, the acting is not to be criticized, and the story is so well constructed that the interest is never for a moment lost. And what more could be asked? The answer is plain. And it is also plain that the exhibitor who advertises "The Man from Home" will pack his house.

It was only a few years ago that David Belasco produced Booth Tarkington's novel of this name on the stage, and now he and the Lasky company are to be thanked for offering it in motion pictures. If the picture is to be classified it will come under the head of comedy-dramas, but it is so far removed from the average comedy-drama that it stands in a very small class of this variety of pictures.

It seems rather useless to speak of the excellent photography as this brand of pictures never contains anything but the best photographic work. Some gorgeous scenes have been obtained. And the light and shadow effects are flawless.

Leading the cast is Charles Richman, who plays the role of Daniel Vorhees Pike, an American country lawyer, equipped with all the subtlety which we would suppose such a gentleman to possess. The way he gets the idea of marrying a bankrupt English lord out of his ward's head is both amusing and tense, and the big situation that his machinations lead all the principals of the play to is immensely dramatic and forcible.

Theodore Roberts has been allotted the role of the Grand Duke Vasili Visilivitch of Russia, and makes the most of his part. Many a humorous scene passes between him and Pike, when the breezy American has struck up an acquaintance with him. Fred Montague has a smaller part as the Earl of Hawcastle, and Monroe Salisbury plays the honorable Almeric St. Aubyn (the Earl's bally offspring) in fine style. His part of the young English lord is exaggerated, but very funny.

Dorothy Quincey and Jode Mullally are the two American children of Old Man Simpson (Dick La Reno), who are all but unbooned by the English lord and his son. Horace B. Carpenter as Ivanoff, and Anita King as Countess de Champigny complete the



IVANOFF'S MAID BEGS FOR FREEDOM

cast, which is one of the most well balanced we have seen for some time.

The main plot deals with Pike's efforts to dissuade the Simpson children from becoming adherents of the penniless Englishmen, which he finally succeeds in accomplishing. There is a sub-plot showing how false the older lord is when he elopes with a Russian's wife and sends Ivanoff to Siberia, which is closely allied with the other.

From the very outset there is not a slow moment. Humorous and dramatic situations have been mixed with great intelligence. There is one big situation to which all the smaller ones lead, which is both powerful and gratifying to see. Then, too, the ability of the cast, and the finished manner in which they perform go a long way in helping the production. In short, the picture is perfect in every degree.

"LITTLE SUNBEAM"

(Balboa-Box Office—Three Reels)

REVIEWED BY CLIFFORD H. PANGBURN

THIS is the sort of picture which if it were told in a printed story would be read with interest by every member of the family. In other words, the human element is present to a pleasing extent.



SUNBEAM ON THE FARM

The characters are neither members of aristocratic foreign houses, nor American millionaires. Instead, they represent the fine, every-day persons of moderate means who make up the great bulk of this country's population. Even the villain is a familiar type.

The mere fact that the characters are of this sort makes their interpretation more difficult, but the cast proves itself a decidedly capable one. Jackie Saunders, who is seen in the title role, displays all of that sweetness and charm which has made her so popular. She is a cheerful, fun-loving little girl, whose chief care is to make those about her happy. The other players give her fitting support.

There is a large number of fine rural scenes during the course of the picture, those showing the interior of the farm house in which Little Sunbeam lives with her sister and foster parents being especially realistic.

The village blacksmith adopts Little Sunbeam and her sister. The sister meets a stranger from the city, who exercises an influence over her which Little Sunbeam instinctively recognizes as an evil one. The blacksmith's daughter had eloped with a stranger some years before and this seems to be what the stranger is planning with the innocent sister. Such proves to be the case.

Little Sunbeam goes to the city in search of her sister. The man who took her from her home has cast her off. The boarding house in which the searcher lives is next door to the house in which the blacksmith's daughter is living. Little Sunbeam plays on her violin, and the old songs influence the erring girl next door to go home. Eventually she finds her sister while posing for an artist, who has fallen in love with her

MOST OF ORIGINAL CAST IN "OFFICER 666"

George Kleine's "Officer 666," which is rapidly being completed by Director Frank Powell, will feature the same cast of characters used in the original stage version of the story, with the exception of the lead of Travers Gladwin, which is being handled by Howard Estabrook because of his special adaptability for the part.

"THE FLOATING CALL"

(Reliance-Mutual—Two Reels)

REVIEWED BY PETER MILNE

PICTURES that combine a story of newspaper life, whether it be true to life or not, and a detective story, are always received with great enthusiasm. "The Floating Call" will be a success, but not for this reason alone. Much of its attractiveness relies on the excellent manner in which it is produced, the pronounced ability of the cast, and again because the story is not a common one.

Fred A. Kelsey directed the picture, and the amount of action and the intense scenes that he has put into the two reels sustain one's interest throughout the two thousand feet. Mr. Kelsey's specialty seems to be this variety of story and that in which the crooks and the railroad play important parts. He hardly has a



BELLA IS MADE CAPTIVE

superior in producing pictures of these thrilling varieties, and this picture is an excellent example of what he can do.

As in all such stories the termination is apparent as soon as the plot has formed. Therefore the development of the picture is the keynote to its success. The situations that arise in the short space of two reels are sufficient to make the picture go, and the way they are developed is most interesting.

Of course the love story is secondary, almost entirely neglected in this instance, but it is doubtful if it will be missed. If love sick souls who care only to see a romance depicted on the screen before them witness this offering they will wish for more.

Leading the cast is Irene Hunt, playing the role of Bella, the reporter, who is mainly the cause of bringing a band of counterfeiters to bay. W. E. Lawrence and George Seigmann are the two head counterfeiters. The city editor is Ralph Lewis and the part of a jealous reporter is carried by Vester Perry. Connors, of the U. S. Secret Service, who is Bella's lover, is played by Robert Burns. The cast is exceptionally well balanced.

"RIP VAN WINKLE"

(Rolfe-Alco—Five Reels)

REVIEWED BY CLIFFORD H. PANGBURN

FOR many years Joseph Jefferson toured the country in his stage version of the story of "Rip Van Winkle." So popular did his play become that he became one of the most widely known actors on the American stage. After his death his son, Thomas Jefferson, took up his father's work and won equal distinction. In common with many other legitimate successes "Rip Van Winkle" has now been prepared for the screen, and with most elaborate settings.

Washington Irving's story was arranged for the stage by the elder Jefferson, and his original manuscript has been used in preparing the film version. Besides this, Thomas Jefferson appears in the title role, thus making the production as close to that seen on the stage as is possible.

The atmosphere of the film is convincing. The scenes which take place in and about the old Dutch village on the Hudson are carefully arranged both as to the houses shown and the costumes of the players. Many fine views in the Catskills show the beauty of the country in which Rip loved to roam with his dog, idling away his time to the distraction and anger of his wife.

Another point of much excellence in the picture is the photography. This is of the best, and many fine lighting effects add to the strength of the film. Part of the action takes place in Rip Van Winkle's house during a thunder storm. The incessant lightning flashes which can be seen through the window are unusually realistic, many of them appearing to light up the whole countryside. Firelight and moonlight effects are also used with entire success.

The story of "Rip Van Winkle" is one with which every child is familiar, and it is only necessary to say that it is faithfully followed from Rip's youthful days of conviviality to his return after his twenty years' sleep, and his ultimate happiness with his daughter.

When the picture opens Mr. Jefferson is shown in his study. He picks up a copy of Rip Van Winkle and becomes absorbed in it. Then the story begins. At its close the actor is seen laying



RIP AND THE CHILDREN

RIP FINDS HIS DAUGHTER

down the book, after which he drinks a health to the picture of his distinguished father as he thinks of Washington Irving's immortal story.

Daisy Robinson makes an attractive Meenie Van Winkle, while her cowardly but persistent lover, Cockles Von Beekman, is well portrayed by William Chamberlain. William Cavanaugh is seen as the swaggering, haughty Derrick Von Beekman, a part which he handles commendably.

The characterization of Nick Vedder, the innkeeper, by H. D. Blakemore is particularly good, as is that of his son, Hendrick, by Wallace Scott. Others in the cast are: Maurice Stewart, Clariet Claire, Loel Stewart, G. Sabo and Walter Kendig. Also the Russian police dog who appears as Rip's canine pet must be mentioned, as he is quite as accomplished a four-footed actor as the screen has seen for some time. The actions of this diverting animal indicate a high order of intelligence.

WHY DID
JUNE
RUN AWAY

WHO IS JUNE?

Why, Her Name Is

RUNAWAY JUNE

"THE NINETY BLACK BOXES"

(101 Bison-Universal—Two Reels)

REVIEWED BY PETER MILNE

IT is a well known fact that great difficulties present themselves in filming a picture adapted from a story, much of whose beauty lies in its descriptions, and intercourse between the characters, and those very difficulties must have been exceptionally hard to overcome by the director of this series taken from George Bronson Howard's stories concerning Francois Villon, which ran in the "Century Magazine." But Charles Giblyn has overcome them in a masterly way, and produced in this picture, which is the fourth of the Francois Villon series, a story that is exceptionally powerful.



VILLON IS SENT OUT ON A DARING MISSION

Villon is again sent on a mission by his master to conquer a haughty lord. He enters his kingdom and makes friends with the man he is sent to kill. The lord, John Balue, keeps his prisoners in small cages, appropriately called black boxes. They are small and the prisoners are unable to stand upright or move about.

Balue takes him in to his dungeons and shows him his means of torture with great pride. Villon manages to secure a key to one of the cages and lets its inmate out, who helps him overpower the oppressor, and then sets all the others free.

Then the party gains the free air, but are pursued by soldiers, with whom they engage in a battle royal, overcoming all but their leader, who manages to escape.

Villon, fearing to return to his master as he was not wholly successful in his mission, joins the band of outlaws of which he was once a member before becoming the agent of Louis.

INDIAN AUTHORITY MAKES \$75,000 MOTION PICTURE

AFTER three years among the little known natives of Alaska and northern British Columbia, Edward C. Curtis has just completed a motion picture drama to be called "In the Land of the Head Hunters." A private exhibition of this remarkable production was given last week in the Vanoscope projection rooms, New York City.

Mr. Curtis is the famous North American Indian authority whose photographs are hung in the art galleries and museums throughout this and other countries. But it is as the author of the \$1,500,000 work, "The North American Indian," the field research for which was conducted under the patronage of the late J. Pierpont Morgan, that Mr. Curtis is perhaps best known.

The motion picture "In the Land of the Head Hunters" has naturally great scientific and educational value, and is artistically of much beauty. But it is no mere collection of scenes from Indian life. "In the Land of the Head Hunters" is an Indian epic drama. The films represent an outlay of \$75,000. A feature of its presentation in leading theatres throughout the country will be orchestral rendering of native music symphonized.

"In the 'Head Hunters' all the characters are North Pacific Indians, and all the action is true to native life. Although he has been a "winter dance brother" with several chiefs of the region for a quarter of a century, Mr. Curtis had to live in a North Coast village for a year before the Indians of that village and two others consented to enact for him the dramatic legends of their clans.

Mr. Curtis states that in all his thirty years of life among aborigines from Mexico to Alaska he has never found Indians living under more primitive conditions than do those who took part in "The Head Hunters." Nor has he ever found natives more suspicious of the camera. Those who understand the temper of the real Indian, as contrasted with the "show Indian," know that only "Chief Curtis," with his knowledge of Indian dialects and Indian character, could have made the films of "The Head Hunters."

These Indians are seafarers. From great cedars they fashion canoes to hold as many as 80 persons, and wrest a livelihood from the ocean. A successful hunt for a 90-foot whale and raids on the clustered sea lion rookeries far out to sea figure in the film. The action proper deals with the love of a young chief, Montana, for Naida. To win her, Montana and his clan have to stamp out the head hunting clan of Yaklus and his brother, the Sorcerer, who covets Naida. Head hunting, Mr. Curtis states, ceased among certain clans in this region only about the middle of the last century. Ceremonial cannibalism and head hunting were concurrent.

"THE TAINT"

(Pathe—Four Reels)

REVIEWED BY CLIFFORD H. PANGBURN

THIS is a story of the inherited tendency for crime, and is full of interesting incidents culminating in an exciting and stirring wreck of a large-sized locomotive. It is the sort of film which ought to produce results at almost any type of theatre.

The interior settings are of the ideal sort which are so carefully arranged for their connection with the story that the spectator gives them little or no thought. Besides this, there is a number of attractive exteriors. Most important of all the film presents a rather improbable narrative in a convincing manner.

The cast is a strong one. The leading part is taken by Ruby Hoffman, who plays first the role of a young girl, and then that of a woman of forty or more. Others are Edward José, Creighton Hale, M. O. Penn, Louis Hendricks and Sam Ryan.

Vera Knight, a country girl, obtains a place as an assistant to a woman scientist. The woman's secretary and bookkeeper wins her affection and then betrays her. He has also stolen money from his employer.

Learning of both his acts the scientist orders him to marry the girl under pain of being sent to jail for theft. He consents, but plans to run away, taking all the valuables about the house. He is surprised by the woman, who is killed in trying to stop him.



VERA SEEKS PEACE

The girl is convicted on circumstantial evidence. She spends twenty years in prison, while her son grows up without knowing who his parents are.

She is released for service to the government and becomes a member of the secret service. She discovers that her son has inherited his father's tendencies and is apparently a criminal.

It finally develops that he is the victim of his own father, who is masquerading under an assumed name. He is killed when a locomotive on which he is seeking to escape the government officers is ditched. The son learns who he is and there is a happy ending. The wrecking of the locomotive is a very spectacular effect, and puts a climax on a strong story.

INTERESTING FILM REVIEWS

PRODUCTIONS FROM ALL PROGRAMS

GENERAL FILM PROGRAM

"A Boomerang Swindle." (Lubin. Tues., Nov. 3.)—A couple of crooks try to swindle an old farmer by bidding against each other for an option on his farm. A young lawyer who is engaged to the farmer's daughter gets the money back several times over and lands the crooks in jail. A good, quiet comedy.

"The Sorceress." (Lubin. Two reels. Wed., Nov. 4.)—A woman having decided to leave her dissolute husband gives her little daughter to gypsies. Before she can claim her she dies. Years later the girl's father meets her and without knowing that she is his daughter tries to betray her. He does not succeed, and on learning who the girl is does his best to atone for his act. Extremely melodramatic. The cast is headed by Lillie Leslie, Margaret Moore, Joseph Smiley and Justina Huff.

"The Choice." (Vitagraph. Thurs., Nov. 5.)—A revenue officer accidentally stumbles on a band of smugglers. He falls in love with the daughter of the leader before he discovers who the men are. He succeeds in having the gang arrested, but refuses the girl's plea to let her father go, as he rates duty higher than love. Then he discovers that his sweetheart's father is another officer who has been posing as a smuggler and that though he has chosen duty he has found love.

"The Stolen Yacht." (Lubin. Two reels. Thurs., Nov. 5.)—The son of a boat builder leaves technical school to help his father. He is in love with the daughter of a wealthy man, who thinks he is of too lowly origin to marry her. When he shows himself to be a man, and also saves the father's yacht from some filibusters he finds himself received with favor. The college scenes are not well done, but the story is a good one. Velma Whitman and L. C. Shumway head the cast.

"Butterflies and Orange Blossoms." (Biograph. Thurs., Nov. 5.)—A rather entertaining comedy romance of a young butterfly collector who is a woman hater. He meets a charming girl in a very informal way, and soon finds himself in love with her. A number of strange experiences add to the fun. In the cast are Irene Howley and William Jefferson.

"Thanks for the Lobster." (Vitagraph. Fri., Nov. 6.)—A rollicking piece of slapstick comedy, with Wally Van acting as principal funmaker. It is in the nature of a satire on the present dancing craze.

"Love Triumphs." (Lubin. Fri., Nov. 6.)—A young lawyer secretly marries a nurse. When he thinks that the marriage, if known, will hurt his plans, he lets her go away to an unknown town. There she is discovered by a doctor who knows her husband and a reconciliation is brought about. Rosemary Theby and Harry Myers are the principals.

"A Regular Rip." (Biograph. Fri., Nov. 6.)—On the same reel with "Getting the Sack." Friends of a vaudeville actor and his wife take advantage of the former's hunting trip to teach him a lesson that ends his bad habits. They make him a modern Rip Van Winkle.

"Getting the Sack." (Biograph. Fri., Nov. 6.)—A girl plans a novel elopement in which her lover's rival is to help. The scheme does not work out according to specifications owing to the unexpected arrival of two burglars. Fairly entertaining. On the same reel with "A Regular Rip."

"In the Land of Arcadia." (Vitagraph. Two reels. Sat., Nov. 7.)—Two old professors have brought up the daughter of one, and an adopted son of another on a beautiful island far from the ordinary world. When they have grown up they go to see the world of ordinary persons, but they soon tire of its frivolities and noise, and go back to their island, where they find happiness together. Lillian Walker and Arthur Cozine are seen as the young couple.

"Kidnapping the Kid." (Lubin. Sat., Nov. 7.)—On the same reel with "The Honor of the Force." A burlesque in which two hoboes kidnap a child. He is a spoiled child and soon leaves

their wheelbarrow for a passing motor. A good comedy.

"The Honor of the Force." (Lubin. Sat., Nov. 7.)—A wild slapstick comedy in which pies and other odd missiles figure in a fight between the police and the "Pig Alley Pugs." On the same reel with "Kidnapping the Kid."

"The Dole of Destiny." (Biograph. Sat., Nov. 7.)—The old story of a girl who trusts her lover too far, only to be thrown over. The lover also shows himself to be a beast in other ways. Justice is eventually done. Not suitable for a neighborhood theatre, but should do well in others. In the cast are Claire McDowell, H. A. Barrows, Charles West, Helen Bray, W. J. Butler, Kate Bruce and Frank Evans.

"Miss Tomboy and Freckles." (Vitagraph. Mon., Nov. 9.)—A lively little comedy in which Lillian Walker is featured as an irrepressible tomboy. The older sister tries to leave "Tommie" out of all her parties, but only succeeds in losing her suitor, who is attracted to the younger girl. A story particularly suited for a neighborhood theatre.

"A Better Understanding." (Biograph. Mon., Nov. 9.)—A country girl marries a young composer from the city. Their happiness is made greater by the husband's rapid success. Later he becomes infatuated with another woman. His wife decides to leave him for his own happiness. Of course there is a happy reconciliation. Irene Howley and Jack Mulhall head the cast.

"Butt-ing In." (Lubin. Tues., Nov. 10.)—On the same reel with "A Bargain Table Cloth." A hobo picks up a cigar butt, only to lose it after a chase by a policeman who is not allowed to buy any smokes. Slapstick comedy.

"A Bargain Table Cloth." (Lubin. Tues., Nov. 10.)—Two jealous women buy table cloths of identical design. A tramp steals one, and the victim thinks her neighbor the thief when she sees her cloth out on the line. Complications ensue. An ingenious idea well worked out. On the same reel with "Butt-ing In."

"The New Magdalen." (Biograph. Two reels. Tues., Nov. 10.)—This film is an adaptation of the novel by Wilkie Collins. A woman who has been forced from the path of virtue by stress of circumstances is truly repentant but finds her efforts rendered vain by the way in which her past keeps coming up. In desperation she impersonates a woman who she supposes is dead. A story of wide appeal. The cast includes Vivian Prescott, Charles Mailes, Louise Valc, George Morgan, Franklin Ritchie and Louie Ducey.

"The Senator's Brother." (Vitagraph. Two reels. Tues., Nov. 10.)—The familiar story of a man who makes a secret marriage for business reasons and then abandons his wife. In this case a brother brings up his daughter, and after many years retribution overtakes him just when he thinks he has won his desire by being elected a United States senator. Leah Baird and William Humphrey head the cast.

"In Bridal Attire." (Vitagraph. Wed., Nov. 11.)—An amusing story of a man who is kept from his wedding by a combination of unfortunate petty accidents. He finally overtakes his bride as she is going away in an automobile, and having dragged a minister with him, is married on the spot. Billy Quirk and Constance Talmadge are the principals.

"The Quack." (Lubin. Two reels. Wed., Nov. 11.)—A drama which utilizes the familiar story of a manufacturer of fake patent medicines who finds that a member of his own family is a victim of his vile compound. In this case it is the man's own son, who dies as a result of using his father's so-called cure. Velma Whitman and L. C. Shumway are seen in the leading parts.

"Lola, the Rat." (Vitagraph. Thurs., Nov. 12.)—A story of the underworld. A young Italian girl is rescued from sickness and misery by a philanthropic doctor. She falls in love with him, but he is engaged and does not notice her feeling. Later the girl saves his life but loses her own. The title role is played by Estelle Mardo.

"In the Hills of Kentucky." (Lubin. Two reels. Thurs., Nov. 12.)—Two campers in the Kentucky hills discover coal on the land belonging to one of the ignorant mountaineers. They try to buy the place but he will not sell. They then resort to two tricks to break up the owner's home and make him willing to sell. They are about to succeed when their schemes are discovered and frustrated. Louise Huff and Douglas Sibole head the cast.

"The Fleur-de-lis Ring." (Biograph. Thurs., Nov. 12.)—The action is supposed to take place in France. Circumstantial evidence points to the guilt of two innocent men accused of murder. They are saved by the testimony of a girl, and the mark of a fleur-de-lis ring worn by the murderer. Melodramatic, but not sensational. Alfred Paget and Isabel Rea head the cast.

"Life's Stream." (Biograph. Fri., Nov. 13.)—An innocent mountain girl meets a man who has learned to master himself. The result is different from what it would have been in many cases. An unusual story of particular appeal. Vola Smith and Alan Hale are the principals.

"The Trap." (Lubin. Fri., Nov. 13.)—An American and a Mexican are rivals for the hand of the daughter of a Mexican general. The Mexican is a traitor, while the American fights fairly and carries off the girl. A fast moving story, with rapid action. Velma Whitman and L. C. Shumway are the principals.

"The Rocky Road of Love." (Vitagraph. Fri., Nov. 13.)—A case of a woman who starts out to capture a man, and as is inevitable, succeeds. The courtship is a rather remarkable one, and is interrupted by many mishaps, but it ends as planned. Flora Finch and Jay Dwiggin are the lovers.

"Helen's Sacrifice." (Kalem. Sat., Nov. 14.)—This is the first of a series of one-reel railroad stories to be known under the general head of "The Hazards of Helen." Helen Holmes makes a spectacular chase after a freight which is about to meet a passenger train on the same track. Her horse jumps from a bluff into a river, and later she gets from the horse to the moving locomotive. Miss Holmes will be featured in the series which is designed to be of a spectacular and sensational nature. This first picture meets expectations in that direction. The others in the cast are J. P. McGowan, Ethel Clisbec and Pearl Hoxie.

"Beating the Burglar." (Lubin. Sat., Nov. 14.)—On the same reel with "Magazine Cooking." A comedy in which a country bumpkin disguises himself as the wife of a stranger who has cut him out with his girl. In this way he stops the wedding and also learns that the man is a burglar. A good story.

"Magazine Cooking." (Lubin. Sat., Nov. 14.)—A young wife who knows nothing of cooking prepares a meal to which her husband invites his employer. A good burlesque story.

"Ann, the Blacksmith." (Vitagraph. Two parts. Sat., Nov. 14.)—Ann Schaefer is featured as a modern Amazon, who besides being a partner in a blacksmith shop, hunts down two desperadoes and almost overcomes them single-handed. The sheriff is so impressed that he asks her to be his wife, and receives an affirmative answer.

"His Wife's Pet." (Biograph. Sat., Nov. 14.)—A clever comedy. A man wishes to get rid of his wife's cat. He is overcome by the chloroform he is using just as a burglar arrives on the scene. The crook steals the cat and the other man starts to throw away his silverware. On the same reel with "The Deadly Despatch."

"Sisters." (Vitagraph. Mon., Nov. 16.)—A factory girl and a wealthy settlement worker are brought into close contact by the fact that they are both in love with married men. Together they overcome their temptation. The two girls are played by Margaret Bibson and Myrtle Gonzalez.

"The Deadly Despatch." (Biograph. Sat., Nov. 14.)—A burlesque of the type of picture which deals with intrigues in foreign courts. On the same reel with "His Wife's Pet."

THE BEST OF DRAWING CARDS

THE WEEK OF NOVEMBER 15th



Released Exclusively Through the Mutual Film Corporation

PHOTOS—8 by 10 photos of the following players can be had by sending to the PUBLICITY DEPT. 15 cents for one, 50 cents for set of four, one dollar for set of eight, etc.

Mabel Normand	Charles Ray	Elizabeth Burbridge	Sid Chaplin
Barney Sherry	Roy Laidlaw	Mack Sennett	Roscoe Arbuckle
Thos. H. Ince	C. N. Mortenson	Walter Belasco	Shorty Hamilton
Enid Markey	Charles Chaplin	John Keller	W. S. Hart
Richard Stanton	Margaret Thompson	Jay Hunt	Walter Edwards
Leona Hutton	Frank Borzage	Jerome Storm	Gertrude Claire
Rhea Mitchell	Harry Keenan	Bessie Barriscale	J. Frank Burke
			Herschel Mayall

KEYSTONE MABEL IN TEN NEW STYLES—15 cents for one, 50 cents for set of four, etc.

PENNANTS—Beautiful colored pennants of our four brands, KAY BEE, KEYSTONE, BRONCHO and DOMINO. 25 cents for one, one dollar for set of four.

New York Motion Picture Corporation

Longacre Building, 42nd St. and Broadway

NEW YORK

AD KESSEL, Jr., President

"Countess Swedie." (Essanay. Mon., Nov. 16.)—Reviewed in MOTION PICTURE NEWS, issue of Nov. 14, page 47.

"Adventure of Lost Wife." (Edison, Mon., Nov. 16.)—Review appeared in MOTION PICTURE NEWS, issue of Nov. 7, page 50.

"A Millinery Mixup." (Edison. Split reel. Wed., Nov. 18.)—Review appeared in MOTION PICTURE NEWS, issue of Nov. 7, page 50.

"Lord Cecil Keeps His Word." (Lubin. Mon., Nov. 16.)—This is the tenth of the "Beloved Adventurer" series, Lord Cecil being told by the swindler that the mine which he owns is the property of an orphan named Elizabeth Lee, consents to restore it to her on the return of the purchase price. Meantime Betty Carson marries him in spite of his poverty. Cecil orders the mine stock delivered to Elizabeth Lee, thus preventing Carson from obtaining it as he had hoped to do. Then he finds that Betty Carson is really Elizabeth Lee, and that he is no longer a poor man. The regular cast is seen.

"The Child Thou Gavest Me." (Biograph. Mon., Nov. 16.)—Two women become mothers of girls at about the same time. While their husbands are away one of the women dies. On the same day the other woman's baby dies. The grief-stricken mother substitutes her dead baby for the live one of the other woman. Her act leads to some remarkable and unforeseen complications.

"The Man of Iron." (Kalem. Two reels. Mon., Nov. 16.)—A man of exceedingly strict ideas causes the arrest of his son for a small theft from himself. His daughter leaves him because of his act. She goes to New York where she drifts unknowingly into bad company. Her brother is released from a short term in prison, and having inherited money goes to the same city. He meets his sister in time to take her home for a happy reunion.

"She Was the Other." (Lubin. Tues., Nov. 17.)—On the same reel with "Cheap Transportation." A small town police chief plans to have his pretty sister inspect the force in order to encourage a neat appearance on the part of the men. The men understand that the inspectress is to be an unattractive old maid. A fairly amusing story.

"Cheap Transportation." (Lubin. Tues., Nov. 17.)—A burlesque trick picture in which a motion picture actor is carried from New York to Florida by a series of surprising accidents. On the same reel with "She Was the Other."

"Ernest Maltravers." (Biograph. Two reels. Tues., Nov. 17.)—This is an adaptation of the novel of the same title by Bulwer-Lytton. It tells of the secret marriage of an Englishman of rank to a gypsy girl, their subsequent separation due to her abduction by her father and his companion, and their reunion after many years. The plot is full of interest. It is a costume play. In the cast are Vivian Prescott, Louise Vale, George Morgan and Jack Drummer.

"Hope Foster's Mother." (Vitagraph. Two reels. Tues., Nov. 17.)—An actress by good luck and determination obtains an important role just when her mother becomes very ill. Her first appearance is a great success because of the cheering telephone message from her mother. As a matter of fact, the old lady is almost at the point of death, but pulls through by what the doctor calls a miracle. Edith Storey is featured.

"The Peach at the Beach." (Kalem. Tues., Nov. 17.)—A slapstick comedy dealing with the adventures of Ham when he tried to entertain a flirtatious neighbor with Mrs. Ham's money. They are caught in a motion picture which is seen some weeks later by their respective spouses. Trouble follows. Lloyd Hamilton and the usual cast.

"His Nemesis." (Kalem. Two reels. Wed., Nov. 18.)—A business man averts financial ruin by a theft which he blames on an old employe. The innocent man's daughter realizes the truth but cannot prove it. She gets revenge by infatuating the crook's son and ruining him. Later she realizes what a horrible thing she has done. She becomes a slum worker, and when her father is released, brings about peace. Helen Holmes heads the cast.

"Fixing Their Dads." (Vitagraph. Wed., Nov. 18.)—Two old widowers are rivals for the hand of a widow. In their jealousy they try to break off the engagement between the son of one and the daughter of the other. Meantime the widow marries a former sweetheart. The young people then get the parental blessing and the old men admit their foolishness. Flora Finch and Jay Diggins are the principals. A good, quick comedy.

"The Marriage Wager." (Lubin. Two reels. Wed., Nov. 18.)—A sensational melodrama which includes one killing and several attempts at murder. A jealous man is trying to rob his

brother of the fortune which he believes should be his. A young clubman happens in time to save the day and marry the daughter of the man saved from attack.

"Too Much Burglar." (Vitagraph. Thurs., Nov. 19.)—The familiar incident of fake burglary arranged with a view to making a man a hero, but spoiled by the arrival of two real burglars. Contains some new situations, however. Estelle Mardo is featured.

"On Suspicion." (Lubin. Two reels. Thurs., Nov. 19.)—The fiancée of a prosecuting attorney has a quarrel with him over the use of the third degree in examining prisoners. Later the girl is arrested on suspicion at a hotel. She is charged with theft and admits it under the third degree, although actually innocent. Her lover discovers her predicament and gets her off. He then admits the evil of the system which he had defended. Entertaining although improbable.

"Henpeck Gets a Night Off." (Biograph. Thurs., Nov. 19.)—Henpeck works the "sitting-up-with-a-sick-friend" stunt to get away to a little party. His wife comes to see how sick the friend is, but she is convinced that all is as it should be. On the same reel with "A Fowl Deed."

"A Fowl Deed." (Biograph. Thurs., Nov. 19.)—A tramp wraps a stolen chicken in a waist closely resembling that worn by a servant girl on her day out. The blood-stained garment is found and causes amusing errors. On the same reel with "Henpeck Gets a Night Off."

"Fatty and the Shyster Lawyer." (Kalem. Fri., Nov. 20.)—A fair comedy with the cast headed by John Brennan. Fatty is inveigled into suing the railroad company when he slips on a banana peel. He feigns paralysis in the court, but when 1,000 volts go through him he is very much alive.

"The Professional Scapgoat." (Vitagraph. Fri., Nov. 20.)—An original comedy in which a young man is hired as one to take the blame for all small complaints in a department store. When a customer complains about anything he is called and "fired," meantime going through motions of grief. Later the hero marries a store girl and inherits money. There are many humorous incidents.

"The Unknown Country." (Lubin. Fri., Nov. 20.)—A strange story of astral bodies and wandering spirits. The villain changes his spirit into his rival's body, but cannot make the change work the other way. When he wants to change back he finds his own body dead and becomes a wandering spirit. The whole production is fanciful in the extreme.

"The Girl and the Miser." (Biograph. Fri., Nov. 20.)—A miser aspired to marry a village girl because she was supposed to be "sensible" in money matters. He shortly has the surprise of his life, which makes a good story. Irene Howley heads the cast.

"Blacksmith Ben." (Biograph. Sat., Nov. 21.)—A blacksmith's sweetheart elopes with an artist. Many years later he finds that his young helper is about to get mixed up in the same sort of trouble, and saves him by force.

"The Plot at the R. R. Cut." (Kalem. Sat., Nov. 21.)—The second episode of "The Hazards of Helen" makes an entertaining picture; delving slightly too much into unnecessary detail is its only fault. The main situation could have been made to appear more important, but as it stands it's a good one. Helen Holmes as the operator patches up the telegraph wires after an explosion has broken them, and obtains help for the wounded men.

"Mary Jane Entertains." (Vitagraph. Two reels. Sat., Nov. 21.)—Mary Jane, the maid, and her sweetheart go to a fashionable ball in the clothes of Mary's master and mistress. Mary's employers then find they can go, and missing their clothes, take a policeman with them. Many laughable complications follow. Hughie Mack as the maid's beau, and Flora Finch as Mary Jane, make a remarkable pair.

"The Daddy of Them All." (Lubin. Sat., Nov. 21.)—A burlesque picture in which the smallest man in town receives the prize for the person having the largest number of children. On the same reel with "The Tale of a Coat."

"The Tale of a Coat." (Lubin. Sat., Nov. 21.)—A tailor conceals a love note to one of the workers in a pocket of a customer's coat. The garment is delivered before the tailor takes out the missive. Two men get into trouble as a result of the note. On the same reel with "The Daddy of Them All."

"The Servant Question." (Essanay. Tues., Nov. 17.)—Reviewed in MOTION PICTURE NEWS, issue of Nov. 14, page 47.

"Proving that Spongers Are Found in a Drug Store." (Essanay. Wed., Nov. 18.)—Reviewed in MOTION PICTURE NEWS, issue of Nov. 14, page 47.

"Buster Brown and the German Band." (Edison. Split reel. Wed., Nov. 18.)—Review appeared in MOTION PICTURE NEWS, issue of Nov. 7, page 50.

"Dixon's Diamonds." (Edison. Sat., Nov. 21.)—Review appeared in MOTION PICTURE NEWS, issue of Nov. 7, page 50.

"A Horse on Sophie." (Essanay. Thurs., Nov. 19.)—Reviewed in MOTION PICTURE NEWS, issue of Nov. 14, page 47.

"Broncho Billy's Scheme." (Essanay. Sat., Nov. 21.)—Reviewed in MOTION PICTURE NEWS, issue of Nov. 14, page 47.

"If I Were Young Again." (Selig. Mon., Nov. 16.)—Reviewed in MOTION PICTURE NEWS, issue of Nov. 14, page 47.

"The Sheriff's Reward." (Selig. Tues., Nov. 17.)—Reviewed in MOTION PICTURE NEWS, issue of Nov. 14, page 47.

"The Broken X." (Selig. Wed., Nov. 18.)—Reviewed in MOTION PICTURE NEWS, issue of Nov. 14, page 47.

"The Mysterious Box." (Selig. Fri., Nov. 20.)—Reviewed in MOTION PICTURE NEWS, issue of Nov. 14, page 47.

"Her Sacrifice." (Selig. Sat., Nov. 21.)—Reviewed in MOTION PICTURE NEWS, issue of Nov. 14, page 47.

UNIVERSAL PROGRAM

"The Mystery of Grayson Hall." (Eclair. Two reels. Wed., Oct. 28.)—A detective story that will command interest, played with force by Fred Hearn as the detective and murdered man. The picture is well developed, and although the murderer is known from the start, the detective's methods are entertaining to watch.

"The Strike at Coaldale." (Eclair. Sun., Nov. 1.)—How a railroad employe saved the life of his employer's daughter by running a train in opposition to the strike breakers makes this a very exciting reel. The cast is headed by Stanley Walpole and Mildred Bright. The train crossing the burning trestle creates suspense.

"An Ill Wind." (Sterling. Mon., Nov. 9.)—Max Asher and the burlesque police force disport themselves to good advantage in this farce. Although one scene in the picture is repeated several times, the whole thing will greatly amuse. The burglar whom the police force have had a great time in catching, turns out to be the mayor, and not a burglar at all.

"The Shoemaker's Eleventh." (Rex. Thurs., Nov. 12.)—Ben Wilson directed himself and Frances Nelson in this picture and has made an unconventional comedy, which will be rewarded by a good deal of laughter. The shoemaker has eleven children. They drive him to distraction and he decides to leave one on a doorstep. The policeman, thinking he is a thief, chase him, and when at last he is caught and brought back to the house, someone else has left another child with his baby, and he has to take them both—but he gets a thousand dollars.

"The Dog Raffles." (Sterling. Thurs., Nov. 12.)—Trained dogs are becoming popular, and the one that appears in this reel is quite an actor. The picture is very funny, besides, as the dog chases a number of men with a stick of burning dynamite. The only trouble is that it is out half the time. The police force plays an important part and the acting of its members will call for a deal of laughter.

"The School Teacher at Angel Camp." (Frontier. Sat., Nov. 14.)—Not to be released. The film falls short of the standard set by the company.

"Lizzie's Escape." (L. K. O. Sun., Nov. 15.)—Review appeared in MOTION PICTURE NEWS, issue of Nov. 7, page 50.

"The Chorus Girl's Thanksgiving." (Rex. Two reels. Sun., Nov. 15.)—Review appeared in MOTION PICTURE NEWS, issue of Nov. 7, page 50.

"Her Own Home." (Eclair. Sun., Nov. 15.)—Review appeared in MOTION PICTURE NEWS, issue of Nov. 7, page 51.

"A Bear Escape." (Sterling. Mon., Nov. 16.)—One of the best of the kid comedies. One of the rivals dresses as a bear in hopes of frightening another, but a real bear turns up and scares all the rivals out of their wits. The object of their affections tames the animal with a lump of sugar.

Cosmofotofilm Co



London Film Co.
(Trade Mark)

"Where the REAL FEATURES come from"

Presents

MR. CYRIL MAUDE

In "BEAUTY AND THE BARGE"

A Gem of Sparkling Humor by England's Greatest Comedian

By W. W. JACOBS

Released through The Paramount Pictures Corporation

"The Phantom Cracksman." (Victor. Mon., Nov. 16.)—Review appeared in MOTION PICTURE NEWS, issue of Nov. 14, page 47.

"Oh, You Mummy!" (Crystal. Split reel. Tues., Nov. 17.)—On the same reel with "Naughty Nellie." Pearl White takes the place of a mummy which is the coveted treasure of an old man and scares him horribly when she moves. This is a fair offering and will produce a few laughs.

"Naughty Nellie." (Crystal. Split reel. Tues., Nov. 17.)—On the same reel with "Oh, You Mummy!" This is such an old topic that it is tiresome. In order that her lover may see her, the girl feigns illness, but the ruse is discovered by father and the young man's exit is hasty.

"Treasure Train." (Imp. Two reels. Mon., Nov. 17.)—Review appeared in MOTION PICTURE NEWS, issue of Nov. 14, page 47.

"His Night Out." (Joker. Wed., Nov. 18.)—Review appeared in MOTION PICTURE NEWS, issue of Nov. 14, page 48.

"His Uncle's Will." (Rex., Thurs., Nov. 19.) Review appeared in MOTION PICTURE NEWS, issue of Nov. 14, page 47.

"The Life Savers." (Crystal. Tues., Nov. 19.)—Two Dutchmen intent on becoming life guards repair to the beach. They are mistaken for counts but later their identity is discovered and they have to run. A fair slapstick, lacking in continuity, but laughable.

"Cupid and the Fishes." (Imp.-Universal Boy, No. 10. Thurs., Nov. 19.)—The United States life savers are shown at work in the first few scenes of this picture, and their maneuvers are exceptionally interesting. Matty, besides getting out the life savers to save a man's life, puts the undesired lover to rout, and leads a romance to a very pretty ending.

"A Scenario Editor's Dream." (Powers. Fri., Nov. 20.)—The distracted scenario editor falls asleep and dreams. In his dream he sees a peaceful town wrecked by bombs dropped from a dirigible. Some quick and clever cuts in the film cause the ruins of once inhabitable houses to appear completely devastated. The scenes in the dirigible are easily "fake," but no not mar the picture. On the whole a very desirable burlesque.

"Man to Man." (Frontier. Sat., Nov. 21.)—Not to be released, as the picture failed to come up to the standard set by the company.

"When Lizzie Got Her Polish." (Nestor. Fri., Nov. 20.)—Review appeared in MOTION PICTURE NEWS, issue of Nov. 14, page 48.

"The Battle of the Nation." (Joker. Sat., Nov. 21.)—Review appeared in MOTION PICTURE NEWS, issue of Nov. 14, page 47.

"For the People." (Victor. Two reels. Fri., Nov. 20.)—Review appeared in MOTION PICTURE NEWS, issue of Nov. 14, page 47.

MUTUAL PROGRAM

"When Vice Shuddered." (Princess. Fri., Nov. 6.)—A cashier having stolen from his bank happens to run into burglars who have just been chased from the place by the police. In the confusion everyone takes it for granted that the bagful of money was being carried away by the burglars. The cashier decides to be honest. A story of considerable interest, well acted.

"The Chasm." (Thanouser. Fri., Nov. 6.)—A girl apparently shields a burglar when she is

really protecting her father. The thief relents but the father has him sent to jail. Later, seeing that his daughter has changed the young man's outlook on life he obtains a pardon for him, and allows him to marry the girl. A quiet family story, but interesting.

"Ethel's Roof Party." (Komic. Sun., Nov. 8.)—Ethel, the stenographer, gives a lunch to her friends on top of the office building. Bill, feeling a little sore, since he was repulsed when he attempted to participate, nails the door shut, and sets fire to a pile of rags, scaring the diners considerably. This is an excellent comedy play by the usual "Bill" cast.

"Keeping a Husband." (Thanouser. Sun., Nov. 8.)—A good idea is embodied in this picture. A twenty-year-old girl comes between a couple who have been married for twenty-five years. She only comes between them for a short time, then the old gentleman wakes up, and all ends well.

"His Talented Wife." (Keystone. Mon., Nov. 9.)—Both Mack Sennett and Charles Murray appear to good advantage in this side-splitting comedy. Murray's wife is a talented actress. He becomes jealous of the leading man, and during the performance impersonates the villain, then a riot ensues. Sennett furnishes a lot of fun as the rube in the audience.

"Our Mutual Girl, No. 43." (Reliance. Mon., Nov. 9.)—Margaret has a rather stirring adventure in the course of this chapter. Ralph Hamilton tells her that his uncle has left him his silk mill in Paterson. Margaret goes to the mill to see Ralph and accidentally discovers that the forewoman, who is almost her double in appearance, is planning with the superintendent to make trouble by starting some unfinished machinery. Disguising herself in one of the forewoman's dresses and locking her into a closet Margaret surprises the superintendent in time to stop him. Ralph comes to her aid just in time.

"The Terror of Anger." (Thanouser. Two reels. Tues., Nov. 10.)—A most thrilling fall of an automobile containing two persons over a cliff comes near the beginning of this reel. It is very well done. The husband whose wife has deserted him and who was killed in the accident resolves to bring up his boy as a savage. In a vision he sees the probable results of such an experiment, which are not favorable, and he decides to forgive and forget his wife.

"The Niggard." (Majestic. Mon., Nov. 10.)—A sensitive young man meets some friends at a shore resort while he is looking for his landlord to pay him the rent. He is accused of being a tight-wad, and uses up his cash in having a good time. As a result his mother and himself are evicted from their cottage. In the cast are Wallace Reid, Cora Drew and Billie West. A picture with a good moral.

"The Widow's Children." (Reliance. Wed., Nov. 11.)—The widow's property is in the way of a proposed fence; the under surveyors proceed to burn down her barn after she has driven them from the grounds. One of her children is slightly burned, but rescued by the head surveyor, who takes an interest in the children, and one of them asks him to become their father. Very pleasantly played by Arthur Mackley and Mrs. Arthur Mackley.

"An Incompetent Hero." (Keystone. Thurs., Nov. 12.)—Roscoe Arbuckle again. Fatty's charitable intentions are mistaken for another kind by the husband of the wife in the house next door. Uproarious situations lead up to a very comical climax laid in a bedroom. It is so funnily constructed, however, that it will not offend. A lot of slapstick work appears after this, which is as hilarious as usual.

"How Heroes Are Made." (Keystone. Sat., Nov. 14.)—Family arrangements have it that Chester Conklin is to marry a charming young girl, but the girl will not have it so. Conklin unknowingly bribes the girl's preferred lover to kidnap her so he may play the hero. After a great deal of laughter has been produced by the funny actions of Conklin, the girl marries her true lover. This is a scream throughout.

"Fatty's Jonah Day." (Keystone. Mon., Nov. 16.)—Fatty sits reading "Three Weeks." A girl whose father happens to have fallen asleep comes and reads with him. The jealous lover arrives on the scene and summons father, and then a side-splitting mix-up ensues, including a few dives off a bridge. In the finale Fatty and the girl resume their book in quiet.

"Shorty Falls into a Title." (Broncho. Two reels. Wed., Nov. 18.)—Review appeared in MOTION PICTURE NEWS, issue of Nov. 7, page 51.

"The Master of the House." (Kay-Bee. Two reels. Fri., Nov. 20.)—A powerful melodrama built along lines that are far out of the ordinary. Some may object to seeing the wife of the Westerner tied to a chair and left there until she consents to read to her husband, but it fits in well with the rest of the situations. The Westerner, who is used to laying down the law with his fists, marries the daughter of a family who have nothing to boast of except their name. After the marriage the family attempt to rule the new member, but he rebels, beats up his father-in-law and tames his wife. Richard Stanton plays the name part with great power.

WARNER'S FEATURES

"Romance of Coyote Hill." (Miller Bros.)—A western comedy drama in which many novel laugh-provoking situations are revealed. This film is rather original in using the old "cowboy-fun-stuff" in that one is hardly conscious that it has all been done before, because the ways of presenting it here are so different. A pleasing heart-interest love story runs through it, and while the plot is an old one and has been used over and over again, nevertheless this one is so different in the handling as to class it better than the average. A good comedy release.

"A Harvest Romance." (Miller Bros.)—Another good western comedy drama. This time the harvest is at hand and harvesting machines of the latest type are seen at work. There is a number of mowers towed by a traction engine, a thrashing machine (gasoline), a wagon-loader and so on, giving a good exhibition of the harvesting of wheat. The farm hand is in love with his employer's daughter, and the foreman, his rival, tries in different ways to discredit him in the eyes of both. The attempted burning of the thrashing machine, the capture of the foreman and his fellow conspirators, at the ford, are very graphically shown. Good outdoor scenes are replete in this number, and as the photography is excellent, this number is sure to please.

"Beazleyhopper Ranch." (Miller Bros.)—Two brothers, A. and O. Beazleyhopper, and a cook disguised as an actress, furnish the fun in this rather "out-of-the-ordinary" comedy. The latter goes west to the ranch of the two brothers. They both soon are seekers for her hand, forgetting their two rustic sweethearts. The love-making of the two brothers, their attempts to drown themselves in six inches of water are all amusing, and the exposure of the "actress" makes a fitting climax. Everything comes out all right, the photography is good, and some really excellent comedy situations mark this number.

Day and Date	Titles of Films Booked	Release Date	Brand	No. Reels	Review appears in Motion Picture News of		Posters Used and Size	Regular or Special	Cost	Advertising Used: Newspapers, heralds, slides, photographs, window cards	Weather	Total Admissions	
					Issue	Page						Matinee	Night
MONDAY													
	Remarks												
TUESDAY													
	Remarks												
WEDNESDAY													
	Remarks												
THURSDAY													
	Remarks												
FRIDAY													
	Remarks												
SATURDAY													
	Remarks												
SUNDAY													
	Remarks												

Record of Current and Coming Releases

GENERAL FILM PROGRAM

RELEASES OF NEXT WEEK

Monday, November 16, 1914.

BIOGRAPH —The Child Thou Gavest Me, D., 995.....	16434
EDISON —The Adventure of the Lost Wife, C., 1000..	16439
ESSANAY —Countess Sweedie, C., 1000.....	16441
KALEM —The Man of Iron, D., 2000.....	16434
LUBIN —Lord Cecil Keeps His Word, Beloved Adventurer Series, D., 1000.....	16442
MINA —The Thrilling Adventures of Count Verace, C., 1000	16443
SELIG —If I Were Young Again, D., 2000.....	16436
Hearst-Selig News Pictorial No. 75, N., 1000.....	16440
VITAGRAPH —Sisters, D., 1000.....	16438

Tuesday, November 17, 1914.

BIOGRAPH —Ernest Maltravers, D., 2011.....	16451
EDISON —A Moment of Madness, D., 1000.....	16444
ESSANAY —The Servant Question, C., 1000.....	16445
KALEM —The Peach at the Beach, C., 1000.....	16540
LUBIN —She Was the Other, C., 400.....	16449
Cheap Transportation, C., 600.....	
SELIG —The Sheriff's Reward, D., 1000.....	16446
VITAGRAPH —Hope Foster's Mother, D., 2000.....	16448

Wednesday, November 18, 1914.

EDISON —Buster Brown and the German Band, C., 400	16453
A Millinery Mix-Up, C., 600.....	
ESSANAY —The Fable Proving That Sponges Are Found in a Drug Store, C., 1000.....	16456
KALEM —His Nemesis, D., 2000.....	16454
LUBIN —The Marriage Wager, D., 2000.....	16459
SELIG —The Broken X, D., 1000.....	16458
VITAGRAPH —Fixing Their Dada, C., 1000.....	16457

Thursday, November 19, 1914.

BIOGRAPH —Henpeck Gets a Night Off, C., 471.....	16461
A Fowl Deed, C., 528.....	
ESSANAY —A Horse on Sophie, C., 1000.....	16462
LUBIN —On Suspicion, D., 2000.....	16463
SELIG —Hearst-Selig News Pictorial No. 76, N., 1000..	16466
VITAGRAPH —Too Much Burglar, C., 1000.....	16465

Friday, November 20, 1914.

BIOGRAPH —The Girl and the Miser, D., 999.....	16476
EDISON —What Could She Do? D., 2000.....	16467
ESSANAY —The Means and the End, D., 2000.....	16470
KALEM —Fatty and the Shyster Lawyer, C., 1000.....	16472
LUBIN —The Unknown Country, D., 1000.....	16475
SELIG —The Mysterious Black Box, C., 1000.....	16473
VITAGRAPH —The Professional Scapegoat, C., 1000...	16474

Saturday, November 21, 1914.

BIOGRAPH —Blacksmith Ben, D., 999.....	16483
EDISON —Dickson's Diamonds, D., 1000.....	16477
ESSANAY —Broncho Billy's Scheme, D., 1000.....	16478
KALEM —The Plot at the R. R. Cut, Hazards of Helen, D., 1000	16482
LUBIN —The Tale of a Coat, C., 400.....	16479
The Daddy of Them All, C., 600.....	
SELIG —Her Sacrifice, D., 1000.....	16484
VITAGRAPH —Mary Jane Entertains, C., 2000.....	16380

RELEASES OF THE WEEK AFTER

Monday, November 23, 1914.

BIOGRAPH —All on Account of the Cheese, C., and Thrown Off the Throne, C., 1000.....	
EDISON —His Chorus Girl Wife, D., 1000.....	
ESSANAY —Sweedie at the Fair, C., 1000.....	
KALEM —The Theft of the Crown Jewels, D., 2000....	
LUBIN —The Serpent Comes to Eden, No. 11 of the Beloved Adventurer Series, D., 1000.....	
SELIG —Out of Petticoat Lane, 2 Reels, D., 2000.....	
SELIG —Hearst-Selig News Pictorial No. 77, N., 1000..	
VITAGRAPH —The Level, D., 1000.....	

Tuesday, November 24, 1914.

BIOGRAPH —The Romance of a Poor Young Man, D., 2000	
EDISON —A Gypsy Madcap, D., 1000.....	
ESSANAY —Beyond Youth's Paradise, D., 1000.....	
KALEM —Tough Luck Smith, C., 1000.....	
LUBIN —Mother's Baby Boy, C., and He Wanted Chicken, C., 1000.....	
SELIG —The Scapegoat, W. D., 1000.....	
VITAGRAPH —The Old Flute Player, D., 2000.....	

Wednesday, November 25, 1914.

EDISON —The Temple of Moloch, D., 1000.....	
ESSANAY —The Fable of Aggie and the Aggravated Attacks, C.-D., 1000.....	
KALEM —The Girl and the Explorer, C., 2000.....	
LUBIN —The Making of Him, D., 2000.....	
SELIG —The Butterfly's Wings, D., 1000.....	
VITAGRAPH —Netty or Letty, C., 1000.....	

Thursday, November 26, 1914.

BIOGRAPH —The Way Back, D., 1000.....	
ESSANAY —Snakeville's Reform Wave, C., 1000.....	
LUBIN —Was His Decision Right? D., 2000.....	
SELIG —Hearst-Selig News Pictorial No. 78, N., 1000..	
VITAGRAPH —Cause for Thanksgiving, C., 1000.....	

Friday, November 27, 1914.

BIOGRAPH —His Old Pal's Sacrifice, D., 1000.....	
EDISON —The King's Move in the City, D., 2000.....	
ESSANAY —Scars of Possession, D., 2000.....	
KALEM —Ham the Iceman, C., 1000.....	
LUBIN —He Waits Forever, D., 1000.....	
SELIG —A Surprise Party, C., 1000.....	
VITAGRAPH —The Musical Barber, C., 1000.....	

Saturday, November 28, 1914.

BIOGRAPH —Little Miss Make Believe, C., 1000.....	
EDISON —The Last of the Hargraves, D., 1000.....	
ESSANAY —Broncho Billy's Double Escape, W. D., 1000	
KALEM —The Girl at the Throttle—Third Episode of the "Hazards of Helen," D., 1000.....	
LUBIN —You Can't Beat Them, C., and The Servant Girl's Legacy, C., 1000.....	
SELIG —The Fates and Ryan, D., 1000.....	
VITAGRAPH —Convict, Costumes and Confusion, C., 2000	

What Do You Need?

LISTING IN THE BUYERS' GUIDE, FOR NAME AND ADDRESS, INCLUDING ONE YEAR'S SUBSCRIPTION TO MOTION PICTURE NEWS—\$8.00 A YEAR, CASH IN ADVANCE. FREE TO ADVERTISERS USING \$100.00 OR MORE WORTH OF DISPLAY SPACE DURING THE YEAR. ADDRESS ADVERTISING DEPARTMENT

ADVERTISING NOVELTIES

Philip Hano, 806-810 Greenwich St., New York.

ANNOUNCEMENT SLIDES

Niagara Slide Co., Lockport, N. Y.

ASBESTOS BOOTHS

Sharlow Bros., 442 W. 42nd St., New York.

CLEANING AND RENOVATING FILM

Film Redeveloping Co. of America, 145 W. 45th St., New York.

Multicolor Film Improving Co., Inc., 15 E. 26th St., New York.

COSTUMERS

Miller-Costumier, 236 South 11th St., Philadelphia, Pa.

DEVELOPING TANKS

A. J. Corcoran, Inc., 9½ John St., New York.

ELECTRIC LIGHTING SETS

The Chas. A. Strelinger Co., Box P-2, Detroit, Mich.

FILMS

(Manufacturers, Dealers and Renters)

American Film Mfg. Co., Chicago, Ill.

Thomas A. Edison, Inc., 275 Lakeside Ave., Orange, N. J.

Essanay Film Mfg. Co., First National Bank Bldg., Chicago, Ill.

General Film Co., 200 Fifth Ave., New York.

George Kleine, 166 N. State St., Chicago, Ill.

Lubin Mfg. Co., Philadelphia, Pa.

G. Melies, 204 E. 38th St., New York.

Mutual Film Corp., 71 W. 23rd St., New York.

New York Motion Picture Corp., Longacre Bldg., New York.

Pathé Freres, 1 Congress St., Jersey City, N. J.

Renfax Film Co., Inc., 110 W. 40th St., N. Y.

Selig Polyscope Co., Chicago, Ill.

The Balboa Amusement Producing Co., Long Beach, Cal.

Thauhouser Film Corp., New Rochelle, N. Y.

Universal Film Mfg. Co., 1600 Broadway, N. Y.

FILM ACCESSORIES

Berlin Aniline Works, 213 Water St., New York.

FILM TITLES, PRINTING, DEVELOPING, ETC.

Commercial Motion Pictures Co., Inc., 220 W. 42nd St., New York.

Centaur Film Co., 670-682 Ave. E, Bayonne, N. J.

Evans Film Mfg. Co., 412-22 W. 216th St., at Broadway, New York.

Gunby Bros., Inc., 145 W. 45th St., New York.

Industrial Moving Picture Co., 223-233 W. Erie St., Chicago.

Standard Motion Picture Co., 5 S. Wabash Ave., Chicago.

Standard Filmprint Corp., 120 School St., Yonkers, N. Y.

FILM REELS

Lang Mfg. Works, Olean, N. Y.

Taylor-Shantz Company, 224 Mill St., Rochester, N. Y.

FURNITURE AND FURNISHING ON RENTAL

William Birns, 103-105 West 37th St., New York.

FEATURE FILMS

Alco Film Corp., 218 W. 42d St., New York.

Alliance Films Corp., 126 W. 46th St., New York.

Albuquerque Film Mfg. Co., Inc., 406 Court St., Los Angeles, Calif.

All Star Feature Corp., 220 W. 42d St., New York.

Ambrosio American Co., 15 E. 26th St., New York.

Bosworth, Inc., 640 N. Olive St., Los Angeles, Cal.

Box Office Attraction Film Rental Co., 130 W. 46th St., New York.

Blinkhorn Photoplays Co., 110 W. 40th St., N. Y.

California Motion Picture Corp., San Francisco, Cal.

Cosmofotofilm Co., 110 W. 40th St., New York.

Cosmos Feature Film Corp., 126-130 W. 46th St., New York City.

Direct-From-Broadway Features Co., 46 W. 24th St., New York.

Eclair Film Co., 126 W. 46th St., New York.

Eclectic Film Co., 110 W. 40th St., New York.

Excelsior Feature Film Corp., Inc., 110 W. 40th St., New York.

G. W. Feature Film Corp., 145 W. 45th St., N. Y.

Features Ideal, 126 W. 46th St., New York.

Famous Players Film Co., 213-229 W. 26th St., New York.

Films Lloyds, Inc., 220 W. 42nd St., New York.

General Film Co., 200 Fifth Ave., New York.

General Feature Film Co., 313 Mallery Bldg., Chicago, Ill.

Gaumont Co., 110 W. 40th St., New York.

Greene's Feature Photo Plays, Inc., 110 W. 40th St., New York.

W. W. Hodkinson, 110 W. 40th St., New York.

Imperial Motion Picture Co. of N. Y., Inc., 1476 Broadway, New York.

Inter-Continent Film Co., 110 W. 40th St., N. Y.

George Kleine Attractions, 166 N. State St., Chicago, Ill.

New York Office: 1476 Broadway.

Jesse L. Lasky Feature Play Co., Longacre Theatre, New York.

Life Photo Film Corp., 220 W. 42nd St., N. Y.

Mecca Feature Film Co., Inc., 126 W. 46th St., New York.

Mohawk Film Co., Times Bldg., New York.

Oz Film Mfg. Co., Santa Monica Blvd., Los Angeles, Cal.

Paramount Pictures Corp., 110 W. 40th St., N. Y.

Phoenix Feature Film Corp., 129-131 Columbus Ave., Boston, Mass.

Photo Play Production Co., 220 W. 42nd St., N. Y.

Picture Playhouse Film Co., 110 W. 40th St., New York.

Playgoers Film Co., Lyric Theatre, New York.

Popular Plays and Players Co., 1600 Broadway, New York.

Progress Film Co., 110 W. 40th St., New York.

Progressive Motion Pictures Corp., Times Bldg., New York.

Ramo Films, Inc., Columbia Theatre Bldg., N. Y.

Roland Feature Film Co., 145 W. 45th St., N. Y.

A. H. Sawyer, Inc., 1600 Broadway, New York.

Select Photo Play Producing Co., Inc., 71 W. 23rd St., New York.

Sterling Camera & Film Co., 145 W. 45th St., New York.

Solax Co., Fort Lee, N. J.

The Masterpiece Film Mfg. Co., 1111 Van Nuys Bldg., Los Angeles, Cal.

The Balboa Amusement Producing Co., Long Beach, Cal.

The Photoplay Productions Releasing Co., 37 S. Wabash Ave., Chicago, Ill.

Union Features, 126 W. 46th St., New York.

Universal Film Mfg. Co., 1600 Broadway, N. Y.

University Films, Inc., 110 W. 40th St., N. Y.

Edw. H. Wagner, Agt., Dania Biofilm Co., 38 Park Place, New York.

World Film Corporation, 130 W. 46th St., N. Y.

Warner's Features, Inc., 130 W. 46th St., N. Y.

LANTERN SLIDE MATS AND REEL BANDS

Lantern Slide Mat Co., 149 W. 35th St., N. Y.

LABELS

Every Ready Roll Label Co., 203-7 W. 40th St., New York City.

LIGHTING PLANTS

Cushman Motor Works, Lincoln, Neb.

LOBBY PHOTOS

The Wyanoak Pub. Co., 136 W. 52nd St., N. Y.

MOTION PICTURE MACHINES AND SUPPLIES

Amusement Supply Co., 160 E. North Fifth Ave., Chicago, Ill.

Behrend Motion Picture Supply House, 440 Fourth Ave., New York.

Calehuff Supply Co., 1301 Race St., Philadelphia, Pa.

Enterprise Optical Co., 568 W. Randolph St., Chicago, Ill.

Lears Theatre Supply Co., Sam Lears, Prop., 509 Chestnut St., St. Louis, Mo.

Oliver Moving Picture Supply Co., 647 Euclid Ave., Cleveland, O.

Picture Theatre Equipment Co., 21 E. 14th St., New York.

Precision Machine Co., 317 E. 34th St., N. Y.

Nicholas Power Co., 90 Gold St., New York.

The Phantoscope Mfg. Co., Washington, D. C.

Sweeley's Photo Supply House, 514-516 Erie Ave., Renova, Pa.

Williams, Brown & Earle, Inc., 916-918 Chestnut St., Philadelphia, Pa.

MOTION PICTURE APPARATUS

Burke & James, Inc., 240-258 E. Ontario St., Chicago, Ill.

MUSICAL INSTRUMENTS

American Photo Player Co., 62 W. 45th St., N. Y.

Rudolph Wurlitzer Co., Cincinnati, O.

OPERA CHAIRS

The Hardesty Mfg. Co., Canal Dover, Ohio.

Steel Furniture Co., Grand Rapids, Mich.

POSTER AND PICTURE FRAMES

Menger & Ring, 442 W. 42nd St., New York.

PIPE ORGANS

Henry Pilcher's Sons, 914-920 Mason Ave., Louisville, Ky.

M. P. Moller, Hagerstown, Md.

PROJECTION LENSES

Bausch & Lomb Optical Co., 569 St. Paul St., Rochester, N. Y.

POSTERS

The Morgan Lithograph Co., Cleveland, Ohio.

RAW FILM

Eastman Kodak Co., Rochester, N. Y.

Cellulose Planchon, Inc., 75 Fifth Ave., N. Y.

David Horsley, 1600 Broadway, New York.

Raw Film Supply Co., 15 E. 26th St., New York.

REWINDERS AND GENERAL SUPPLIES

L. C. Smith Co., Schenectady, N. Y.

SCREENS

Atsco, Inc., 218 West 42nd St., New York.

Day & Night Screens, Inc., 110 W. 40th St., N. Y.

Mirror Screen Co., Inc., Shelbyville, Ind.

STEEL FILM EQUIPMENT FOR EXCHANGES AND MFPS.

Columbia Metal Box Co., 226-228 E. 144th St., New York.

TICKETS—ROLL AND COUPON

Rees Ticket Co., 400 S. 10th St., Omaha, Neb.

THEATRE LOBBY FRAMES AND FIXTURES

Newman Mfg. Co., 715 Sycamore St., Cincinnati, O.

UNIFORMS

Fechheimer Bros., Union-made Uniforms, Cincinnati, O.

VENTILATION, COOLING AND HEATING

Typhoon Fan Co., 1544 Broadway, New York.

RECORD OF CURRENT AND COMING RELEASES — Continued

UNIVERSAL PROGRAM RELEASES OF NEXT WEEK

Monday, November 16, 1914.	
IMP—The Treasure Train, D., 2000.....	4266
STERLING—A Bear Escape, C., 1000.....	4269
VICTOR—Mary Fuller in The Phantom Cracksman, D., 1000	4268
STRAND—War News No. 10, N., 1000.....	4270
Tuesday, November 17, 1914.	
CRYSTAL—Oh You Mummy and Naughty Nellie.....	4277
GOLD SEAL—The Opened Shutters, 4000.....	4273
UNIVERSAL SPECIAL—The Master Key.....	4271
Wednesday, November 18, 1914.	
ECLAIR—The Wondrous Melody, D., 2000.....	4279
JOKER—His Night Out, C., 1000.....	4278
Thursday, November 19, 1914.	
IMP—The Universal Boy in Cupid and The Fishes, 1000	4282
REX—His Uncle's Will, D., 2000.....	4283
ANIMATED WEEKLY—No. 141, N., 1000.....	4281
STERLING—Noodles' Return, C., 1000.....	4285
Friday, November 20, 1914.	
NESTOR COMEDY—When Their Brides Got Mixed, C., and India's Defender of the British Empire, E.	4286
POWERS—A Scenario Editor's Dream, C., 1000.....	4287
VICTOR—For the People, D., 2000.....	4288
Saturday, November 21, 1914.	
101 BISON—The Ninety Black Boxes, D., 2000.....	4292
FRONTIER—A Relic of Olden Days, D., 1000.....	4291
JOKER—The Battle of the Nations, C., 1000.....	4290
Sunday, November 22, 1914.	
ECLAIR—A Friend in Need, D., and Our Beloved Country, E., Split Reel.....	4295
L-KO—The Groom's Doom, C., 1000.....	4296
REX—Traffic in Babes, C., 1000.....	4294

RELEASES OF THE WEEK AFTER

Monday, November 23, 1914.	
IMP—His Gratitude (Mary Pickford Reissue), D., 1000.	
VICTOR—Terrence O'Rourke—Gentleman Adventurer —"The Empire of Illusion," D., 1000.....	
STERLING—Black Hands, C., 1000.....	
Tuesday, November 24, 1914.	
GOLD SEAL—The Mysterious Rose, D., 1000.....	
CRYSTAL—Sammie's Vacation, C., 1000.....	
NESTOR—As We Journey Through Life, D., 1000....	
Wednesday, November 25, 1914.	
JOKER—The Tricky Flunkie, C.; La Rochelle, Ed., 1000	
ECLAIR—The Heiress and the Crook, D., 2000.....	
ANIMATED WEEKLY—Weekly No. 142, W., 1000..	
Thursday, November 26, 1914.	
IMP—Human Hearts, D., 3000.....	
REX—No Release this week	
STERLING—Dot's Elopment, C., 1000.....	
Friday, November 27, 1914.	
NESTOR—In Taxi No. 23, C., 1000.....	
POWERS—Sissy Dobbins, Oil Magnate, C. D., 1000..	
VICTOR—The Heart of Night Wind, D., 2000.....	
Saturday, November 28, 1914.	
JOKER—He Married Her Anyhow, C.; Eccentric Comiques, Ed., 1000.....	
FRONTIER—The Best Man, 1000.....	
101 BISON—The Brand of His Tribe, W. D., 2000.....	
Sunday, November 29, 1914.	
REX—Lights and Shadows, D., 2000.....	
L-KO—The Blighted Spaniard, C., 1000.....	
ECLAIR—The Ghost of the Mine, D., 1000.....	

MUTUAL PROGRAM RELEASES OF NEXT WEEK

Monday, November 16, 1914.	
AMERICAN—Old Enough to Be Her Grandpa, C., 1000.	02623
KEYSTONE—Fatty's Jonah Day, C., 1000.....	02607
RELIANCE—Our Mutual Girl No. 44, 1000.....	02606
Tuesday, November 17, 1914.	
BEAUTY—When Queenie Came Back, C., 1000.....	02611
MAJESTIC—The Little Country Mouse, D., 1000.....	02610
THANHOUSER—Pawns of Fate, D., 2000.....	02608
Wednesday, November 18, 1914.	
AMERICAN—Beppo, D., 1000.....	02614
BRONCHO—Shorty Falls Into a Title, C.,.....	02612
RELIANCE—The Hidden Message, D., 1000.....	02615
Thursday, November 19, 1914.	
DOMINO—Nipped, D., 2000.....	02616
KEYSTONE—The Noise of Bombs.....	02618
MUTUAL WEEKLY—No. 99, N., 1000.....	02619
Friday, November 20, 1914.	
AMERICAN—Old Enough to Be Her Grandpa, C., 1000.	02623
KAY BEE—The Master of the House, D., 2000.....	02620
PRINCESS—The Bad Mistake, C., 1000.....	02622
Saturday, November 21, 1914.	
KEYSTONE—Fatty's Wine Party.....	02626
RELIANCE—His Responsibility, D., 2000.....	02624
ROYAL—Love Finds a Way, C., 1000.....	02627
Sunday, November 22, 1914.	
KOMIC—Ethel Has a Steady (Bill No. 11), C., 1000....	02630
MAJESTIC—The Saving Grace, D., 2000.....	02628
THANHOUSER—A Messenger of Gladness, D., 1000..	02631
RELEASES OF THE WEEK AFTER	
Monday, November 23, 1914.	
AMERICAN—In the Candle Light, D., 2000.....	
KEYSTONE—His Taking Ways.....	
RELIANCE—Our Mutual Girl No. 45, 1000.....	
Tuesday, November 24, 1914.	
BEAUTY—As a Man Thinketh, D., 1000.....	
MAJESTIC—Another Chance, 1000.....	
THANHOUSER—Mrs. Van Ruyter's Stratagem, 2000..	
Wednesday, November 25, 1914.	
AMERICAN—The Archaeologist, D., 1000.....	
BRONCHO—The Cross in the Desert, 2000.....	
RELIANCE—They Never Knew, 1000.....	
Thursday, November 26, 1914.	
DOMINO—The Mills of the Gods, 2000.....	
KEYSTONE—Title Not Yet Announced.	
MUTUAL WEEKLY—No. 100, 1000.....	
Friday, November 27, 1914.	
KAY BEE—A Crook's Sweetheart, 2000.....	
RELIANCE—The Hop Smugglers, 1000.....	
PRINCESS—The Wild Woolly West, C., 1000.....	
Saturday, November 28, 1914.	
KEYSTONE—Title Not Yet Announced.	
RELIANCE—The Kaffir's Skull, 2000.....	
ROYAL—Before and After.....	
Sunday, November 29, 1914.	
KOMIC—A Corner in Hats	
MAJESTIC—The Sisters, D., 2000.....	
THANHOUSER—A Denver Romance.....	

"THE STRAIGHT ROAD"

(Famous Players—Faramount—Four Reels)
REVIEWED BY PETER MILNE

A YOUNG girl's rapid journey upon the downward path makes a very interesting, though often distasteful subject for a picture. Therefore when the order is reversed, and we see the girl traveling the opposite direction, the sight is both gratifying and refreshing to the eye. And as the former event doesn't occur half as often as it is professed to, and the latter one happens oftener than is thought by some misguided souls, its depiction on the screen makes it more realistic than the former, and of course pleasanter to witness.

In "The Straight Road," the author, Clyde Fitch, has drawn a strong portrayal of the reformation of a girl, who literally came from the gutter. The play shows to great advantage on the screen; it is impressive, its situations are tense, the characterizations rendered by the players are finished portrayals enacted by stars of an equal calibre.

Gladys Hanson appears as Mary O'Hara, the girl of the slums who rises from the low level of life in which she was reared and who at the risk of her own name lays bare the true and disgraceful character of Aines, who is engaged to a social worker. Arthur Hoops is cast as the man Douglas Aines and impersonates the character admirably.

He brings out the evil and lustful character of his part with striking precision, so well that one is inclined to think it could have been done no better. Ruth Thompson, the well-meaning but misguided young woman who is in love with Aines, is played by Lorraine Huling. William Russell is Bill Hubbell, the saloon keeper. He seems a little too refined-looking for his part, but doubtless there are refined appearing bartenders as well as less reputable men.

He is of athletic build, and when he knocks out a promising white hope in his back room and a little later floors a stalwart negro, any doubts which may have arisen before concerning his ability for his job are speedily squelched. Iva Shepard has a smaller part as Lazy Liz, a woman of the streets.

The sets of the production are realistic and the scenes well chosen; the photography in the print viewed is not quite up to the standard of the company, but the film is delicately tinted and the light is good throughout.

"The Straight Road" will be witnessed with pleasure by all. The story is carefully constructed; the attention is always held; the climax is reached by a series of events each of which has a powerful meaning which is driven home by the good acting of the cast. The ending is happy for all concerned, except the villain, who receives his just deserts. On the whole, "The Straight Road" is a fine picture:

HEARST-SELIG NEWS PICTORIAL NO. 72

UP-TO-DATE and the very latest war news pictures are shown in the Hearst-Selig "News Pictorial No. 72," released Thursday, November 5. There are also news pictures of the great

Illinois mine disaster and other leading features. How the European war has made millions of women and children homeless is vividly portrayed. Other interesting parts of the war section are a batch of German prisoners being led away by Belgian soldiers, King Edward's Regiment of Horse leaving London for the front and English raw recruits being drilled at Aldershot.

The mine disaster at Royalton, Ill., in which fifty men were killed was the most striking of the domestic topics. The scenes were all made the day after the explosion occurred and while the bodies were still being brought to the surface. There is also an excellent picture of the new military aeroplane designed and built by Glenn Martin, being tried out at San Diego, Cal. An interesting novelty is the picture of the girl messengers on rollers.

EDMUND BREESE IN "THE WALLS OF JERICHO"

EDMUND BREESE, who will soon be starred in the Box Office Attraction Company's production of Alfred Sutro's remarkable play, "The Walls of Jericho," is one of America's most intelligent character actors, and has had an enviable career on the stage.

Mr. Breese supported Mme. Rhea. In 1898 he played with James O'Neil in "The Count of Monte Cristo" and "Virginius," after which he was one of the principal members of "The Three Musketeers" with a cast which included Blanche Bates and Margaret Anglin.

His most notable achievement, however, came next when he was cast as John Burkett Ryder in "The Lion and the Mouse." His work in that role established him on the American stage. He then went to London and Americans saw little of Mr. Breese for some time.

He later appeared in "The Spendthrift," Porter Emerson Brown's big success, the author of "A Fool There Was," and recently at the Harris Theatre appeared in "The Master Mind."

COMMERCIAL BIOPHONE CO. EXPANDS

ARRANGEMENTS have just been completed whereby the Commercial Biophone Company, of 110 West 40th street, New York City, takes over the contract formerly held by Pathe Freres controlling the entire output for the United States and Canada of the productions of Messter and Autor films of Berlin, including the Hennie Porten Series.

The first shipment of sample prints has arrived, and announcements to the trade may be expected in the near future.

COXEN IN DARING ROPE-CLIMBING SCENE

A MOTION picture actor's nerve and ability to do the almost impossible is to a great extent illustrated in "The Stolen Masterpiece," a Flying A production in which Ed Coxen and Winnifred Greenwood are featured.

In this picture Mr. Coxen is called upon to climb for considerable distance up a ladder hand over hand, his feet dangling in the air, and old mother earth five stories below.

WHY DID JUNE RUN AWAY

WHO IS JUNE?

Why, Her Name Is

RUNAWAY JUNE

AYOR

WHY DID JUNE RUN AWAY

WHO IS JUNE?

Why, Her Name Is

RUNAWAY JUNE

RELEASE DATES FOR READY REFERENCE

GENERAL FILM PROGRAM

BIOGRAPH

- 11- 6. A Regular Rip, C..... 476
- Getting the Sack, C..... 523
- 11- 7. The Dole of Destiny, D..... 996
- 11- 9. A Better Understanding, D.....1000
- 11-10. The New Magdalen, D.....2073
- 11-12. The Fleur-de-lis Ring, D..... 998
- 11-13. Life's Stream, D.....1000
- 11-14. His Wife's Pet, C..... 477
- The Deadly Despatch, C..... 521
- 11-16. The Child Thou Gavest Me, D..... 995
- 11-17. Ernest Maltravers, D.....2011
- 11-19. Henpeck Gets a Night Off, C..... 471
- A Fowl Deed, C..... 528
- 11-20. The Girl and the Miser, D.....1000
- 11-21. Blacksmith Ben, D..... 999

COLUMBUS

- 10-27. Mulligan's Ghost, C.....1000
- 11- 3. A Twisted Affair, C.....1000
- 11-10. A Family Intermingle, C..... 500
- Oh! What a Dream, C..... 500

EDISON

- 10-27. The Mystery of the Sealed Art Gallery, D.....1000
- 10-28. The Lost Melody, D.....1000
- 10-30. The Midnight Ride of Paul Revere, D.....2000
- 10-31. The Hand of Iron, D.....1000
- 11- 3. Shorty, D.....1000
- 11- 4. Jenks and the Janitor, C..... 500
- Buster Brown, C..... 500
- 11- 7. Getting to the Ball Game, C.....1000
- 11- 9. With Slight Variations, C.....1000
- 11-10. The Heritage of Hamilton Cleek, D.....1000
- 11-13. A Question of Identity, D.....2000
- 11-14. The Everlasting Triangle, D.....1000
- 11-16. The Adventures of the Lost Wife, C.....1000
- 11-17. A Moment of Madness, D.....1000
- 11-18. Buster Brown and the German Band, Cart..... 400
- A Millinery Mix-up, C..... 600
- 11-20. What Could She Do? D.....3000
- 11-21. Dickson's Diamonds, D.....1000
- 11-23. His Chorus Girl Wife, D.....1000
- 11-24. A Gypsy Madcap, D.....1000
- 11-25. The Temple of Moloch, D.....1000
- 11-27. The King's Move in the City, D.....2000
- 11-28. The Last of the Hargroves, D.....1000
- 11-30. Wood B. Wedd Goes Snipe, C.....1000

ESSANAY

- 11-10. Within Three Hundred Pages, D.....1000
- 11-11. Three Boiled Down Fables, C.....1000
- 11-12. Sophie and the Man of Her Choice, C.....1000
- 11-14. Broncho Billy's Decision, D.....1000
- 11-16. Countess Sweedie, C.....1000
- 11-17. The Servant Question, C.....1000
- 11-18. Proving That Spungers Are Found in a Drug Store, C.....1000
- 11-19. A Horse on Sophie, C.....1000
- 11-21. Broncho Billy's Scheme, D.....1000
- 11-23. Sweedie at the Fair, C.....1000
- 11-24. Beyond Youth's Paradise, D.....1000
- 11-25. The Fable of Aggie and the Aggravated Attacks, C.....1000
- 11-26. Broncho Billy's Double Escape, D.....1000

KALEM

- 10-31. The Vengeance of Winona, D.....1000
- 11- 2. His Inspiration, D.....1000
- 11- 3. Lizzie, the Life Saver, C..... 2000
- 11- 4. The Prison Stain, D.....2000
- 11- 6. The Indian Suffragettes, C..... 2000
- 11- 7. The Man in the Vault, D..... 2000
- 11- 9. The Riddle of the Green Umbrella, D..... 2000
- 11-10. The Widow's Might, C..... 2000
- 11-11. A Midnight Tragedy, D..... 2000
- 11-13. Ham, the Piano Mover, C..... 2000
- 11-14. Helen's Sacrifice, D..... 2000
- 11-16. The Man of Iron, D.....2000
- 11-17. The Peach at the Beach, C..... 2000
- 11-18. His Nemesis, D..... 2000
- 11-21. The Plot at the R. R. Cat, D..... 2000
- 11-23. The Theft of the Crown Jewels, D..... 2000
- 11-24. Tough Luck Smith, C..... 2000
- 11-25. The Girl and the Explorer, C..... 2000
- 11-27. Ham the Iceman, C..... 2000
- 11-28. The Girl at the Throttle, D..... 2000
- 11-30. Her Bitter Lesson, D.....2000

KLEINE

- 9-29. A Shot from Ambush, D.....2000
- 10- 6. The Wrecked Special, D.....2000
- 10-13. On the Battle Line, D.....2000

LUBIN

- 11- 3. The Boomerang Swindle, C.....1000
- 11- 4. The Sorceress, D.....2000
- 11- 5. The Stolen Yacht, D.....2000
- 11- 6. Love Triumphs, D.....1000
- 11- 7. Kidnapping the Kid, C..... 400
- The Honor of the Force, C..... 600
- 11- 9. The Beloved Adventurer, Series No. 9, D.....1000
- 11-10. Butt-Ing In, C..... 400
- A Bargain Table Cloth, C..... 600
- 11-11. The Quack, D.....2000
- 11-12. In the Hill of Kentucky, D.....2000
- 11-13. The Trap, D.....1000
- 11-14. Beating the Burglar, C..... 400
- Magazine Cooking, C..... 600
- 11-16. The Beloved Adventurer, No. 10, D.....1000
- 11-17. She Was the Other, C..... 400
- Cheap Transportation, C..... 600
- 11-18. The Marriage Wager, D.....2000
- 11-19. On Suspicion, D.....2000
- 11-20. The Unknown County, D.....1000
- 11-21. The Tale of a Coat, C..... 400
- The Daddy of Them All, C..... 600
- 11-23. The Beloved Adventurer, No. 11, D.....1000
- 11-24. Mother's Baby Boy, C..... 400
- He Wanted Chicken, C..... 600
- 11-25. The Making of Him, D.....2000
- 11-25. Was His Decision Right? D.....2000
- 11-26. He Waits Forever, D.....1000
- 11-27. You Can't Beat Them, C..... 400
- The Servant Girl's Legacy, C..... 600

RELEASE DAYS

GENERAL FILM PROGRAM

- Monday—Biograph, Edison, Essanay, Hearst-Selig News Pictorial, Kalem, Selig, Vitagraph.
- Tuesday—Columbus, Edison, Essanay, Geo. Kleine, Lubin, Selig, Vitagraph.
- Wednesday—Edison, Essanay, Kalem, Lubin, Selig, Vitagraph.
- Thursday—Biograph, Essanay, Hearst-Selig News Pictorial, Lubin, Selig, Vitagraph.
- Friday—Edison, Essanay, Kalem, Selig, Lubin, Vitagraph.
- Saturday—Biograph, Edison, Essanay, Kalem, Lubin, Vitagraph, Selig.

UNIVERSAL PROGRAM

- Monday—Victor, Imp, Powers.
- Tuesday—Gold Seal, Crystal, Nestor.
- Wednesday—Nestor, Joker, Eclair.
- Thursday—Imp, Rex, Frontier, Sterling, Animated Weekly.
- Friday—Nestor, Powers, Victor.
- Saturday—Joker, Frontier, 101 Bison.
- Sunday—Rex, Crystal, Eclair, L-KO.

MUTUAL PROGRAM

- Monday—American, Keystone, Reliance.
- Tuesday—Beauty, Majestic, Thanouser.
- Wednesday—American, Broncho, Reliance.
- Thursday—Domino, Keystone, Mutual Weekly.
- Friday—Kay-Bee, Majestic, Princess.
- Saturday—Keystone, Reliance, Royal.
- Sunday—Majestic, Komic, Thanouser.

MINA

- 11-16. The Thrilling Adventures of Count Verace, C.....1000

SELIG

- 10-31. At the Transfer Corner, C.....1000
- 11- 2. Rosemary, That's for Remembrance, D..... 1500
- 11- 3. The Telltale Knife, D.....1000
- 11- 4. "C. D." D.....1000
- 11- 5. Hearst-Selig News Pictorial, No. 72, N.....1000
- 11- 6. No Wedding Bells for Her, C.....1000
- 11- 7. The Losing Fight, D.....1000
- 11- 9. When His Ship Came In, D.....2000
- 11- 9. Hearst-Selig News Pictorial No. 73, N.....1000
- 11-10. The Ranger's Romance, D.....1000
- 11-11. Peggy, of Primrose Lane, D.....1000

- 11-12. Hearst-Selig News Pictorial No. 74, N.....1000
- 11-13. Cupid Turns the Tables, C.....1000
- 11-14. The Fatal Note, C.....1000
- 11-16. If I Were Young Again, D.....2000
- 11-16. Hearst-Selig News Pictorial No. 75, N.....1000
- 11-17. The Sheriff's Reward, D.....2000
- 11-18. The Broken X, D.....1000
- 11-19. Hearst-Selig News Pictorial No. 76, N.....1000
- 11-20. The Mysterious Black Box, C.....1000
- 11-21. Her Sacrifice, D.....1000

VITAGRAPH

- 11- 2. The Mystery of Brayton Court, D.....1000
- 11- 3. On the Stroke of Five, D.....2000
- 11- 4. The Evolution of Percival, C.....1000
- 11- 5. The Choice, D.....1000
- 11- 6. Thanks for the Lobster, C.....1000
- 11- 7. In the Land of Arcadia, D.....2000
- 11- 9. Miss Tomboy and Freckles, C.....1000
- 11-10. The Senator's Brother, D.....2000
- 11-11. In Bridal Attire, C.....1000
- 11-12. Lola, the Rat, D.....1000
- 11-13. The Rocky Road of Love, C.....1000
- 11-14. Ann, the Blacksmith, D.....1362
- Making of a Newspaper, E..... 638
- 11-16. Sisters, D.....1000
- 11-17. Hope Foster's Mother, D.....2000
- 11-18. Fixing Their Dads, C.....1000
- 11-19. Too Much Burglar, C.....1000
- 11-20. The Professional Scapgoat, C.....1000
- 11-21. Mary Jane Entertains, C.....2000
- 11-23. The Level, D.....1000
- 11-24. The Old Flute Player, D.....2000
- 11-25. Netty or Letty, C.....1000
- 11-26. Cause for Thanksgiving, C.....1000
- 11-27. The Curing of Myra May, C.....1000
- 11-28. Convict, Costumes and Confusion, C.....2000
- 11-30. Everything Against Him, D.....1000

UNIVERSAL PROGRAM

ANIMATED WEEKLY

- 11-11. Weekly No. 140, N.....
- 11-18. Weekly No. 141, N.....
- 11-25. Weekly No. 142, N.....1000

101 BISON

- 11-21. The Ninety Black Boxes, D.....2000
- 11-28. The Brand of His Tribe, D.....1000
- 12- 5. Foundlings of Father Time, D.....2000

CRYSTAL

- 11- 2. They Didn't Know, C.....
- 11-10. The Life Saver, C.....
- 11-17. Oh! You Mummy, and Naughty Nellie, split reel.....
- 11-24. Sammie's Vacation, C.....1000

ECLAIR

- 11- 8. At the Crucial Moment, D.....
- 11-11. The Yellow Streak, D.....2000
- 11-15. Her Own House, D.....
- 11-18. The Wondrous Melody, D.....2000
- 11-22. A Friend in Need, and Our Beloved Country; split reel.....
- 11-25. The Heiress and the Crook.....2000
- 11-29. The Ghost of the Mine, D.....1000
- 12- 2. For the Mastery of the World, D.....3000

FRONTIER

- 10-24. The Scarecrow's Secret, D.....
- 10-31. The Blacksmith's Daughter, D.....
- 11- 7. The Girl from Texas, D.....
- 11-14. The Moccasin Print, D.....
- 11-21. A Relic of Olden Days.....

GOLD SEAL

- 11-10. The Trey o' Hearts, No. 15, D.....3000
- 11-17. The Opened Shutters.....4000
- 11-24. The Mysterious Rose, My Lady Raffles Series, D.....2000
- 12- 1. The Ghost of Smiling Jim, D.....2000

PATHE



Another genuine scene from

THE PATHÉ NEWS

which shows more and better views of today's epoch-making events than any other news film made.

A world-wide organization, a world-wide reputation, and unequalled facilities account for the enviable position of the world's most widely circulated film.

The Pathé News is a voucher for the reputation of the exhibitor who shows it. Show it twice a week. Issued through the Eclectic Feature Film Exchanges.

ECLECTIC FEATURE FILM EXCHANGES FOR YOUR USE

- | | | | | |
|--|--------------------------------------|---|--|--|
| ATLANTA
61 Walton St. | DALLAS
Andrews Bldg. | MINNEAPOLIS
4th and Hennepin Sts. | PHILADELPHIA
1235 Vine St. | SAN FRANCISCO
67 Turk St. |
| BOSTON
3 Tremout Row | DENVER
Nassau Bldg. | NEW ORLEANS
910 Gravier St. | PITTSBURGH
715 Liberty Ave. | SEATTLE
810 Thrd Ave. |
| CHICAGO
5 So. Wabash Ave. | KANSAS CITY
928 Main St. | NEW YORK
115 E. 23rd St. | PORTLAND
392 Burnside Ave. | ST. LOUIS
3210 Locnst St.. |
| CINCINNATI
217 E. 5th St. | LOS ANGELES
114 E. 7th St. | OMAHA
1312 Farnam St. | SALT LAKE CITY
68 South Main St. | SYRACUSE
214 E. Fayette St. |
| CLEVELAND
622 Prospect Ave., S. E. | | | | WASHINGTON
7th & E Sts., N. W. |

THE ECLECTIC
110 West 40th Street



FILM COMPANY
New York City

"The Cream of American and European Studios"

RELEASE DATES FOR READY REFERENCE — Continued

IMP

10—29. In Self-Defense, D.....	2000
11—2. The Turn of the Tide.....	2000
11—5. The Universal Boy in "The Mystery of the New York Docks".....	2000
11—9. The Stronger Love, Mary Pickford Reissue, D.....	
11—12. Peg of the Wilds, D.....	2000
11—16. The Treasure Train, D.....	2000
11—19. The Universal Boy in "Cupid and the Fishes".....	
11—23. His Gratitude, Mary Pickford Reissue, D.....	1000
11—26. Human Hearts, D.....	3000
11—30. The Coward, D.....	2000

JOKER

10—31. When Their Wives Joined the Force, C.....	
11—4. The Hoodoo, and Educational.....	
11—11. The Frankfurter Salesman's Dream, C.....	
11—14. Defeat of Father, and Educational, C.....	
11—18. His Night Out, C.....	
11—21. The Battle of the Nations, C.....	
11—24. The Tricky Flunkie, C., and La Rochelle, E., Split Reel.....	
11—28. He Married Her Anyhow, C., and Eccentric Comiques, E., Split Reel.....	

L-KO

11—22. The Groom's Doom, C.....	
11—29. The Blighted Spaniard, C.....	

NESTOR

10—9. He Never Said a Word, C.....	
10—16. The Way of Life, D.....	
10—23. Cupid Pulls a Tooth, and Mt. St. Bernard, Switzerland; split reel.....	
10—27. The Wall of Flame, D.....	
11—3. The Boy Major, D.....	
11—6. Those Were the Happy Days, C.....	2000
11—10. The Two Thieves, D.....	
11—13. When the Girls Were Shanghaied, C.....	
11—20. When Their Brides Got Mixed, C., and India's Defender of the British Empire, E.....	
11—24. As We Journey Through Life, D.....	1000

NESTOR COMEDY

11—27. In Taxi 23, C.....	1000
---------------------------	------

POWERS

10—30. The Senator's Lady, D.....	
11—6. Nan of the Hills, D.....	
11—13. Sissy Dobbins' Oil Magnet, C.....	
11—20. A Scenario Editor's Dream, C.....	
11—27. Sissy Dobbins, Oil Magnate, D.....	1000
12—4. The Heart of a Magdalene, D.....	1000

REX

10—22. Olaf Erickson—Boss, D.....	2000
10—25. The Little Blond Lady, D.....	
10—29. White Roses, D.....	
11—1. The Vagabond, D.....	2000
11—5. Let Us Have Peace, C.....	2000
11—8. The Link That Binds, D.....	2000
11—12. The Shoemaker's Eleventh, C.....	
11—15. The Chorus Girl's Thanksgiving, D.....	2000
11—19. His Uncle's Will, D.....	2000
11—22. Traffic in Babes, C.....	
11—29. Lights and Shadows, D.....	2000

STERLING

11—12. The Dog Raffles, C.....	
11—16. A Bear Escape, C.....	
11—19. Noodles' Return, C.....	
11—23. Black Hands, C.....	1000
11—26. Dot's Elopement, C.....	1000

UNIVERSAL IKE

10—6. The Neglected Wife.....	
10—13. Mary Green's Husband, and Educational, C.....	
10—13. Mary Green's Husband, and The Monkey Cabaret, C., split reel.....	

VICTOR

11—9. Terrence O'Rourke, Gentleman Adventurer, D.....	2000
11—13. Mary Fuller in "Girl of the People," D.....	2000
11—16. Mary Fuller in "The Phantom Crackman," D.....	
11—20. For the People, D.....	2000
11—23. Terrence O'Rourke, The Empire of Illusion, D.....	2000
11—27. Mary Fuller in The Heart of Night Wind, D.....	2000

MUTUAL FILM PROGRAM

AMERICAN

11—9. Red Bird Wins, D.....	2000
11—11. The Stolen Masterpiece, D.....	1000
11—16. Red Bird Wins, D.....	2000
11—18. Beppo, D.....	1000
11—20. Old Enough to Be Her Grandpa, C.....	1000
11—23. In the Candle Light, D.....	2000
11—25. The Archaeologist, D.....	1000
12—2. The Strength of Ten, D.....	1000

BEAUTY

10—27. A Rude Awakening, C.....	1000
11—3. The Tightwad, D.....	1000
11—10. Motherhood, D.....	1000
11—17. When Queenie Came Back, C.....	1000
11—24. As a Man Thinketh, D.....	1000

BRONCHO

11—2. The City of Darkness.....	
11—18. Shorty Falls Into a Title, C.....	2000
11—25. The Cross in the Desert.....	2000
12—2. A Romance of Old Holland.....	2000

DOMINO

11—5. In Old Italy.....	
11—12. The Friend.....	2000
11—19. Nipped.....	2000
11—26. The Mills of the Gods.....	2000
12—3. The Vigil.....	2000
12—10. Not of the Flock.....	2000
12—17. The Flower in the Desert.....	2000

KAY-BEE

10—30. The Worth of a Life.....	
11—6. In the Clutches of the Gangster.....	2000
11—13. The Hateful God.....	2000
11—20. The Master of the House.....	2000
11—27. A Crook's Sweetheart.....	2000
12—4. Mother of the Shadows.....	2000

KEYSTONE

9—24. The New Janitor, C.....	1000
9—28. Hard Cider, C.....	1000
10—1. Killing Horace, C.....	1000
10—3. Fatty Again, C.....	1000
10—5. Their Ups and Downs, C.....	1000
10—8. Hello Mabel, C.....	1000
10—10. Those Love Pangs, C.....	1000
10—12. Anglers, C.....	1000
10—15. High Spots on Broadway, C.....	1000
10—19. Dash, Love and Splash, and Santa Catalina Islands, split reel.....	
10—22. Love Siege, C.....	1000
10—24. Stout Heart but Weak Knees, C.....	1000
10—26. Shot in the Excitement, C.....	1000
10—26. Dough and Dynamite, C.....	2000
10—29. Gentlemen of Nerve, C.....	1000
10—31. Cursed by His Beauty, C.....	1000
11—2. Lovers' Post Office, C.....	1000
11—5. Curses They Remark'd, C.....	1000
11—7. His Musical Career, C.....	1000
11—9. His Trusting Places, C.....	2000
11—12. An Incompetent Hero, C.....	1000
11—14. How Heroes Are Made, C.....	1000
11—16. Fatty's Jonah Day, C.....	1000

KOMIC

11—1. Casey's Vendetta.....	
11—8. Ethel's Roof Party (No. 10).....	
11—15. Out Again, In Again.....	
11—22. Ethel Has a Steady (No. 11).....	
11—29. A Corner in Hats.....	
12—6. Bill No. 12.....	

MAJESTIC

10—20. Environment.....	
10—25. Paid with Interest.....	2000
10—27. A Mother's Influence.....	
11—1. Paid with Interest.....	
11—3. False Pride.....	
11—8. The Tear That Burned.....	2000
11—10. The Niggard.....	
11—13. The Folly of Ann.....	
11—15. The Odalisque.....	2000
11—22. The Saving Grace.....	2000
11—24. Another Chance.....	
11—29. The Sisters.....	2000
12—1. The Old Good for Nothing.....	

MUTUAL WEEKLY

11—1. No. 92.....	
11—8. No. 93.....	
11—15. No. 94.....	
11—22. No. 95.....	
10—27. No. 96.....	
11—3. No. 97.....	
11—10. No. 98.....	
11—17. No. 99, N.....	1000

PRINCESS

10—9. The One Who Cared, D.....	
10—16. The Touch of a Little Hand.....	
10—23. The Face at the Window.....	
10—30. The Dead Line.....	
11—6. When Vice Shuddered.....	
11—13. Seeds of Jealousy.....	
11—20. The Bad Mistake.....	

RELIANCE

10—24. A Blotted Page.....	2000
10—26. Our Mutual Girl No. 41.....	
10—30. The Availing Prayer.....	
10—31. The Wrong Prescription.....	
11—2. Our Mutual Girl No. 42.....	
11—4. The Miner's Peril.....	
11—7. A Woman Scorned.....	
11—9. Our Mutual Girl No. 43.....	
11—14. The Floating Call.....	
11—16. Our Mutual Girl No. 44.....	
11—18. The Hidden Message.....	
11—21. His Responsibility.....	2000
11—23. Our Mutual Girl No. 45.....	
11—25. They Never Knew.....	
11—27. The Hop Smugglers.....	
11—28. The Kaffir's Skull.....	2000
11—30. Our Mutual Girl No. 46.....	

ROYAL

10—31. Phil's Vacation.....	
11—7. Max's Money.....	
11—14. A Fortune in Pants.....	
11—21. Love Finds a Way.....	
11—28. Before and After.....	
12—5. Sherman Was Right—It's Very Trying.....	

THANHOUSER

10—4. A Dog's Love.....	
10—6. The Cripple.....	
10—9. The Benevolence of Conductor 786.....	
10—11. The Rescue.....	
10—13. The Diamond of Disaster.....	2000
10—18. Left in the Train.....	
10—20. Old Jackson's Girl.....	2000
10—25. Mr. Cinderella.....	
10—27. A Madonna of the Poor.....	2000
11—1. Shep's Race with Death.....	2000
11—3. The Turning of the Road.....	
11—8. Keeping a Husband.....	
11—10. The Terror of Anger.....	
11—13. The Chasm.....	
11—15. The Man with the Hoe.....	
11—17. Pawns of Fate.....	2000
11—22. A Messenger of Gladness.....	
11—24. Mrs. Van Ruyter's Stratagem.....	2000
11—29. A Denver Romance.....	

RELEASE DATES FOR READY REFERENCE — Continued

FEATURE RELEASES

ALCO FILM CORPORATION

ALL STAR

10— 5. The Nightingale, D.....5 parts
 10—19. Shore Acres.....5 parts
 The Easiest Way.....

CALIFORNIA MOTION PICTURE CORP.

11— 2. Salomy Jane.....5 parts
 Mrs. Wiggs of the Cabbage Patch..

LIFE PHOTO FILM CORPORATION

Sept. Captain Swift, D.....5 parts
 Oct. The Ordeal, D.....5 parts
 Dec. Springtime.....

POPULAR PLAYS AND PLAYERS

10—12. The Ragged Earl, D.....
 10—26. Michael Strogoff, D.....5 parts
 11— 9. The Tigress.....

B. A. ROLFE PHOTO PRODUCTIONS

Nov. Rip Van Winkle.....5 parts
 The Three of Us.....

TIFFANY MOTION PICTURE CORP.

Heart of Maryland.....

ALLIANCE FILMS CORPORATION

EXCELSIOR FEATURE FILM CO.

11—23. When Fate Leads Trump.....

FAVORITE PLAYERS

11—16. The Man Who Couldn't Lose.....
 The Last Chapter.....

PROGRESSIVE MOTION PICTURE CO.

11— 2. McVeagh of the South Seas, D....5 parts

SELECT PHOTO-PLAY PRODUCING CO.

10—26. At the Old Cross Roads, D.....5 parts

MASTERPIECE FILM COMPANY

11— 9. The Hoosier Schoolmaster.....5 parts
 The Truth Wagon.....

APEX

Sept. Queen of the Counterfeiters, D.....4 parts
 Oct. Called to the Front; or Europe at War, D.....3 parts

BOX OFFICE ATTRACTION CO.

BALBOA

Sept. Criminal Code.....4 reels
 Oct. Rose of the Valley.....2 reels
 Oct. Test of Manhood.....3 reels
 Oct. Little Sunbeam.....3 reels
 Oct. The End of the Bridge.....3 reels
 Nov. Little Jack.....3 reels
 Nov. Message of the Mind.....3 reels
 Nov. The Call of the Heart.....2 reels

NEMO

Sept. The Winner.....3 reels
 Oct. Through the Night to Light.....3 reels
 Oct. The Vow.....3 reels
 Oct. Through Fire and Water.....2 reels
 Oct. Seeds of Jealousy.....3 reels
 Nov. Bitter Sweets.....3 reels

WHITE STAR

Sept. Storms of Life.....2 reels
 Oct. The Awakening.....3 reels
 Oct. The Judge's Wife.....3 reels
 Oct. A Great Secret.....3 reels
 Oct. The Bracelet.....3 reels
 Nov. The Mask.....2 reels
 Nov. To Love and to Hold.....2 reels
 Nov. Vengeance of the Flames.....3 reels

BOX OFFICE ATTRACTIONS—Special Features

11— 9. Life's Shop Window.....
 11—19. The Walls of Jericho.....
 11—29. The Thief.....

BLINKHORN PHOTOPLAYS

Nov. Lena Rivers, D.....5 reels
 Nov. Jane Eyre, D.....4 reels
 Nov. The Witness Invisible, D.....3 reels
 Nov. The Aviator Traitor, D.....3 reels

COSMOS FEATURE FILM CORPORATION

Lena Rivers, D.....5 parts
 Hearts and Flowers, D.....5 parts
 The Little Girl That He Forgot.....

COSMOFOTOFILM CORPORATION

Sept. England's Menace, D.....3 parts
 Oct. England Expects—, D.....
 Nov. For Home and Country.....2 parts
 Nov. She Stoops to Conquer.....4 parts
 Nov. The Two Columbinas and A Christmas Carol.....

Nov. Called Back.....4 parts
 Nov. Beauty and the Barge.....4 parts

ECLECTIC FILM COMPANY

Perils of Pauline, No. 14, D.....
 Colonel Heeza Liar in the Wilderness, C.....700
 Strange Animals, E.....300
 Pathé Daily News No. 62-1914, Top...
 The Colonel's Wife, D.....
 Pathé Daily News No. 63-1914, Top...
 Pathé Daily News No. 64, Top.....
 Second Door Left, C.....
 War Stricken Louvain, Topical.....
 Pathé Daily News No. 65, Top.....

Oct. The Ticket of Leave Man, D.....3 parts
 Oct. The King of the Air, D.....3 parts
 Oct. The Count That Took the Count, C...
 Oct. The Warning, D.....3 parts
 Oct. The Broken Promise, D.....4 parts
 Oct. Miss Cinderella, C.....

The Poor Little Rich Boy.....
 Whiffles Has a Toothache.....
 A Change of Heart.....
 A World Without Men.....
 The Perils of Pauline, 16th Episode.
 A Soldier's Duty.....
 Nov. The Old Foggy.....
 Nov. The Taint.....4 parts

E. & W. TRANSFILM BUREAU

Oct. Modern Warfare, D.....6 parts

HEPWORTH-AMERICAN

Aug. The Girl from the Sky, C.....
 8—29. The Chimes, D.....3 parts
 The Terror of the Air, D.....2 parts
 Sept. Creatures of Clay, D.....3 parts

HECTOR FILM CORPORATION

Sept. Born Again, D.....5 parts

KINETOPHOTE CORPORATION

10—26. Markia, or The Destruction of Carthage.....5 reels
 11— 2. Born Again.....5 reels
 11—16. The Coming Power.....4 reels
 11—23. The Spirit of the Poppy.....6 reels
 12— 7. The Span of Life.....5 reels
 12—21. The Little Jewess.....4 reels

OZ FILM COMPANY

Oct. Patchwork Girl of Oz.....5 parts
 Oct. His Majesty, The Scarecrow of Oz...5 parts
 Nov. The Last Egyptian.....

PARAMOUNT PICTURES

BOSWORTH

10— 1. Pursuit of the Phantom.....5 parts
 10—19. Hypocrites!.....4 parts
 11—23. The Country Mouse.....4 parts

FAMOUS PLAYERS

10—26. Behind the Scenes.....5 parts
 11— 9. Man from Mexico.....5 parts
 11—30. Mrs. Black Is Back.....
 12—21. Step Sisters, D.....5 parts
 12—28. The Crucible, D.....5 parts
 12—31. The Million, D.....4 parts

JESSE LASKY COMPANY

10—22. What's His Name?.....5 parts
 11—16. The Rose of the Rancho.....5 parts
 11—26. The Man from Home.....5 parts
 12— 7. Ghostbreaker, D.....5 parts

LASKY-LIEBLER

12—24. Cameo Kirby, D.....5 parts

SMALLEYS

12—17. False Colors, D.....5 parts

PLAYGOERS FILM COMPANY

Oct. The Great Diamond Robbery, D....6 parts

PICTURE PLAYHOUSE FILM COMPANY, INC.

11— 2. For King and Country.....
 11—10. The Last Dance.....
 11—18. The Wild Flower.....
 11—26. The Black Envelope.....
 12— 2. Convict 555.....
 12—10. Partners.....

RENOVED PLAYERS

Sept. A Great Mistake, D.....5 parts

UNITED FILM SERVICE

WARNER'S FEATURES, INC.

LUNA

11—12. Reuben's Busy Day, C.....1 reel
 11—19. Sage Brush Leading Lady, C.....1 reel

MITTENTHAL

11— 8. The Tenor of a Great City.....3 reels

PREMIER

11—14. Gypsy's Warning, D.....1 reel
 11—21. Bandit of Devil's Gap, D.....1 reel
 The Prospector's Warning.....1 reel

SAVOIA

11— 8. The Last Chord.....3 reels

STARLIGHT

11—10. The Villain Still Pursued Her, C...1 reel
 11—17. Noisy Neighbors, C.....1 reel

WARNER'S FEATURES

Oct. Hunted Down, D.....
 Oct. In the Duke's Power, D.....
 Oct. Bess of the Blazing Sea, D.....
 Oct. The Adventures of Kitty Cobb, D...
 Oct. False Pride Has a Fall, C.....3 parts
 Oct. The Hypnotic Violinist, D.....3 parts
 Even Unto Death, D.....
 Nov. The Serum of Reason.....4 parts

WORLD FILM CORPORATION

10— 5. A Gentleman from Mississippi....5 parts
 10—12. The Man of the Hour.....5 parts
 10—19. The Mystery of Edwin Drood....5 parts
 10—26. When Broadway Was a Trail....5 parts
 11— 2. Across the Pacific.....5 parts
 11— 9. The Wishing Ring.....5 parts
 11—16. One of Millions.....4 parts
 11—23. Lola.....5 parts
 11—30. The Dancer and the King.....5 parts
 12— 7. The Marked Woman.....
 12—14. As Ye Sow.....
 12—21. The Pit.....5 parts

ANIMATED SONGS

Imperial Motion Picture Co., New York
 Latest Releases:

There's a Lonesome Little Girl in a Lonesome Little Town.
 She Was My Dad's First Sweetheart.
 Down Where the Old Road Turns.
 Push It Along.
 She's Just a Bird in a Gilded Cage.



“SHORE ACRES”

WITH CHARLES A. STEVENSON

JAMES A. HERNE'S

MASTERPIECE IN FIVE PARTS



THE TRUE NEW ENGLAND CLASSIC

Adapted for a Photo-play by
LOUIS REEVES HARRISON

Produced by
AUGUSTUS THOMAS

Released Through
ALCO FILM CORPORATION



ALL STAR FEATURE CORPORATION

220 W. 42nd ST., N. Y.

Studios and Laboratories, Fort Lee, N. J.

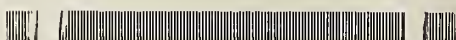

Be sure to mention "MOTION PICTURE NEWS" when writing to advertisers.

EXCLUSIVE MOTION PICTURES OF THE YALE-HARVARD GAME

INCLUDING

THE WONDERFUL NEW YALE BOWL, THE ACTION PARTS OF THE GAME, THE INDIVIDUAL PLAYERS AND STARS, THE OPPOSING COACHES AND THEIR METHODS OF PRACTICING AND TRAINING, THE MASCOTS AND CHEERLEADERS, THE SEVENTY THOUSAND SPECTATORS, THE SNAKE DANCE OF THE STUDENTS; PROMINENT PEOPLE AT THE GAME, INCLUDING EX-PRESIDENTS TAFT AND ROOSEVELT; AND INTERESTING INCIDENTS THAT MAKE THIS GAME THE LARGEST ATTENDED SPORTING EVENT IN THE WORLD.

DISTRIBUTED BY

E & W TRANSFILM BUREAU

110 W. 40th St., New York, (Phone Bryant 4526)

TERRITORY BUYERS—WIRE TO THE DISTRIBUTORS FOR NEW ENGLAND, NEW YORK STATE AND CITY, NEW JERSEY, PENNSYLVANIA, DELAWARE, DISTRICT OF COLUMBIA, AND MARYLAND. FOR RENTALS, COMMUNICATE WITH THE DISTRIBUTORS.

Attractive two-color one-sheets.

This is an Exclusive, will not be shown by film weeklies.

PRODUCED BY THE

COLONIAL MOTION PICTURE CORPORATION

18 E. 41st St., New York

“HARD TIMES” FLY OUT OF THE WINDOW

When MOTION PICTURE NEWS Comes In By The Mail

Ask any live wire Exhibitor if it's true

Are you reading ACCESSORY NEWS?

**WHY DID
JUNE
RUN AWAY**

WHO IS JUNE?
Why, Her Name Is
RUNAWAY JUNE

? ? ? ? ? ? ? ? ? ? ? ?

**WHY DID
JUNE
RUN AWAY**

WHO IS JUNE?
Why, Her Name Is
RUNAWAY JUNE

Cosmofotofilm Co



London Film Co.
(Trade Mark)

"Where the REAL FEATURES come from"
TWO GREAT CHRISTMAS OFFERINGS!
"THE TWO COLUMBINES" (2 Parts)
 AND
"A CHRISTMAS CAROL" (1 Part)
Released through the Paramount Pictures Corporation
World's Tower Bldg., 110 W. 40th St., New York

LORIMER JOHNSTON JOINS BALBOA

The Balboa Amusement Producing Company has contracted with Lorimer Johnston, one of the best known and most talented producers of feature films, to take charge of a newly organized company of players. He has taken up the filming of a three-reel drama, "The Light in a Woman's Eyes," from a scenario written by F. M. Wiltermood, editor at the Balboa studio at Long Beach, Cal. Among the members of the new company are several noted thespians, including Caroline Frances Cooke, Constance Johnson, Douglas Gerrard, Howard Davies, William Carroll and Ben F. Clinton.

KERRIGAN RENEWS CONTRACT WITH UNIVERSAL

The Universal Film Manufacturing Company announces the signing of a new contract with Jack Kerrigan of the Kerrigan-Victor Company, which covers a period of two years. While Mr. Kerrigan's popularity is too well known to require any particular word, it is interesting to learn that during his work with the

Universal he has been awarded first prize in three contests and second and third in seven others. He is at present working on a series by Louis Joseph Vance, called "Terrence O'Rourke."

Jacques Jaccard will continue to act as co-director with Mr. Kerrigan in the production of the future releases.

LIFE PHOTO PLANS STUDIO IN CALIFORNIA

A new western studio at San Diego, California, has been decided upon by the Life-Photo Film Corporation, which is now releasing through Alco. The great variety that the scenery of California offers to the film producer appeals to the officials of the producing organization. It is entirely possible, they say, to have forests, rivers, flat lands, and prairies (at least moving picture prairies) within easy reach of the central plant. At the same time there is of course no restriction on the production in California of modern interiors.

Jesse J. Goldburg, secretary of Life-Photo, and Leonard Abrahams, vice-president, are arranging their business affairs so that they can get away in a few days.

Jane Eyre

BY
CHARLOTTE BRONTE

A FOUR PART

PRODUCTION WHICH WILL MORE THAN SATISFY THE MILLIONS OF READERS OF THE BOOK, AND ONE THAT WILL THRILL THOSE WHO ARE NOT FAMILIAR WITH THIS WONDERFUL STORY OF LOVE AND ADVENTURE.

NOW READY WITH A FULL LINE OF ADVERTISING MATTER

110 W. 40th St. **WHITMAN FEATURES CO.** NEW YORK
 PHONE, 5667 BRYANT

Cosmofotofilm Co



London Film Co.
(Trade Mark)

"Where the REAL FEATURES come from"

"CALLED BACK"

HUGH CONWAY'S GREAT MELODRAMA In Four Parts Produced by the LONDON FILM CO.
For Exclusive Rights, Address us at

World's Tower Bldg., 110 W. 40th St., New York

TITLES

Our *Title Department* has been re-organized, elaborately equipped and placed under the direction of recognized experts.

Its highly perfected apparatus, lino-type machine and job presses enable us to produce the most difficult title work in any language—artistically, accurately and *quickly*—and at *lower prices* than have ever yet been quoted.

DEVELOPING AND PRINTING

Save money and insure the best results by entrusting your work to the *largest and most complete commercial plant in America.*

CENTAUR FILM CO.

Bayonne, N. J., and 1600 Broadway, N. Y.

BALBOA FILM BREAKS LONG BEACH RECORD

Los Angeles, Cal., Nov. 9.

RECORDS were made at the Columbia theatre, Long Beach, Cal., when the Balboa feature, "The Will o' the Wisp," was shown for three nights. Each evening the police department sent four men to the theatre to protect the Pike—the amusement street at the beach resort—from being blocked by the crowds. The former record for the house was made three years ago, when "The Pilgrim's Progress" was shown.

LUBIN FILMS GEORGE ADE COMEDY

THE Lubin company are now staging George Ade's "The College Widow," which will feature Ethel Clayton and George Soule Spencer. The foot ball game will be played with all the vigor of the real battle between rival colleges. The comedy is being staged by Barry O'Neil, who has a free hand to make the comedy one of the features of the season.

It Is a Wise Exhibitor

Who watches what the other fellows are doing. You can get complete information describing business boosting schemes employed by exhibitors everywhere by reading every issue of

MOTION PICTURE NEWS

This ad. pinned to a check, bill or money order for \$2, will bring it to you for one year.



A STORY GRAPHICALLY TOLD OF IRELAND'S STRUGGLE FOR FREEDOM IN 6 PARTS



THE RECORD TO DATE:

- 100 PERFORMANCES AT THE 44th ST. THEATRE, N. Y. CITY.
- 75 PERFORMANCES AT THE CHESTNUT ST. OPERA HOUSE, PHILA., PA.
- 64 PERFORMANCES AT THE CRESCENT THEATRE, BROOKLYN, N. Y.
- NOW IN ITS FOURTH WEEK AT THE NATIONAL THEATRE, BOSTON, MASS.

IRELAND A NATION

PRESS COMMENT

You'll come out of the 44th St. Theatre with wet eyes and smiling lips.—N. Y. American.
A well photographed and interesting movie drama.—N. Y. Times.
Greeted with applause never before given a photo play.—N. Y. Telegraph.
There is much to recommend in this offering.—N. Y. Star.
A very interesting series of moving pictures.—N. Y. Tribune.
A rather unusual entertainment was welcomed.—N. Y. Sun.

FOR STATE RIGHTS AND TERMS, ADDRESS



UNITED BOOKING OFFICE FEATURE PICTURE CO., INC.
Palace Theatre Bldg.,
1564 Broadway, New York.

WESTERN VAUDEVILLE MANAGERS ASSOCIATION
Majestic Theatre Bldg.,
Chicago, Ill.



**ALLIANCE
PROGRAM**

HEARTS AND FLOWERS

In Five Parts

FEATURING **MRS. THOMAS WHIFFEN**

The grand old lady of the dramatic stage, and

MISS BEULAH POYNTER

The popular emotional actress, supported by a large cast. Produced by

COSMOS FEATURE FILM CORP. Released Nov. 30

EXCHANGES

ALLIANCE FILM SERVICE, 115 Fourth Ave., Pittsburgh, Pa. A. A. Weiland, Mgr. Ohio, Western Pennsylvania, and West Virginia.

ALL THEATRES FILM CO., 18 Chapin Block, Buffalo, N. Y. S. S. Webster, Mgr., Times Bldg., Troy; John F. Heffron, Mgr., Troy. New York State.

ALLIANCE FILM SERVICE, 128 West 46th St., New York City. M. F. Tobias, Mgr. New York City.

ALLIANCE FILM SERVICE, controlled by Eastern Feature Film Co., Inc., 57 Church St., Boston, Mass. New England.

ALLIANCE FEATURE FILM SERVICE, controlled by Mecca Feature Film Co., 130 West 46th St., New York City. Northern New Jersey.

ELECTRIC THEATRE SUPPLY CO., Vine and 13th St., Philadelphia, Pa. Southern New Jersey, Eastern Pennsylvania, Maryland, Delaware, District of Columbia.

APEX FEATURE SERVICE, 417 Rhodes Building, Atlanta, Ga. O. P. Hall, Mgr. Virginia, North Carolina, South Carolina, Georgia, Florida, Alabama, Mississippi, and Louisiana.

APEX FEATURE SERVICE, 510 McCall Bldg., Memphis, Tenn. M. Simmonds, Mgr. Tennessee.

APEX FEATURE SERVICE, 311 Andrews Bldg., Dallas, Texas. M. Levison, Mgr. Texas, Arkansas, and Oklahoma.

CASINO FEATURE FILM CO., Dime Savings Bank Bldg. Detroit, Mich. Michigan.

CELEBRATED PLAYERS FILM CO., 64 W. Randolph St., Chicago, Ill. Illinois and Indiana.

NAT A. MAGNER CO., Pacific Bldg., San Francisco, Cal. 218 Superba Theatre Bldg., Los Angeles, Cal. California, Nevada and Arizona.

APEX FEATURE SERVICE, Seattle, Wash. M. Winik, Mgr. Washington, Oregon, Montana and Idaho.

DES MOINES FILM SUPPLY CO., 218 Utica Bldg., Des Moines, Ia. Iowa.

MONARCH FEATURE FILM CO., 12th and Wyandotte Sts., Kansas City, Mo. Missouri, Kansas and Nebraska.

ZENITH FEATURE FILM CO., Lyceum Bldg., Duluth, Minn. Minnesota, North and South Dakota and Wisconsin.

RELEASES

THE KEY TO YESTERDAY
THE PATH FORBIDDEN
AT THE OLD CROSS ROADS
McVEAGH OF THE SOUTH SEAS
THE HOOSIER SCHOOLMASTER

THE MAN WHO COULD NOT LOSE
WHEN FATE LEADS TRUMP
THE UNDER TRAIL
THE LAST CHAPTER
THE TRUTH WAGON

ALLIANCE FILMS CORPORATION

126 W. 46th Street

New York City



*Offices,
110 W. 40th St.
New York* *Studios,
Los Angeles
California.*

Presents

Carlyle Blackwell

In

The Five Part Photo Play

The Man Who Could Not Lose

From The Book By

Richard Harding Davis

A Notable Star

A Popular Story

A Famous Author

Previous Release

The Key To Yesterday

In Four Parts

From the Book By

Chas. Nevil Buck

*Booked Through
the*

*Alliance
Film Corporation*



THE PRODUCTIONS OF
FAMOUS PLAYERS FILM CO. JESSE L. LASKY FEATURE PLAY CO. BOSWORTH INC.
 In Association with Associated with Associated with
 Daniel Frohman David Belasco Lois Weber
 Chas. Frohman-Henry W. Savage The Liebler Company Phillips Smalley
CONSTITUTE

Paramount Pictures



THIS is a reproduction of our latest advertisement in the *Saturday Evening Post*.

Hundreds of thousands of people are reading this ad. who will look up *Paramount Pictures* and go to see them in their local theatres. We are mailing hundreds of booklets daily to these readers who are really interested in *Paramount Pictures*.

In this way a clientele of the best people is being built up for the *Exhibitors of Paramount Pictures*.

Isn't that valuable cooperation ?

Write our nearest exchange *now* about securing *Paramount Service* for your theatre, and thus get the benefit of *Paramount advertising*



Paramount Pictures Corporation
 ONE HUNDRED and TEN WEST FORTIETH STREET
 NEW YORK, N. Y.

"THE BARGAIN"

Produced for
Paramount Pictures Corporation

by
THOMAS H. INCE
PRODUCER OF THE TYPHOON

Featuring **William S. Hart** in feats
of incomparable daring

A Great Western Story of Love
and Chance

Scenes are laid in the magni-
ficent Grand Canyon of Arizona one
of the World Wonder Spots

Every one everywhere should see
this picture

Write our nearest exchange
for bookings



Paramount Pictures Corporation
ONE HUNDRED and TEN WEST FORTIETH STREET
NEW YORK, N.Y.



SPECIAL FEATURES

General Film Company

TITLE	MAKE	No. of Reels	TITLE	MAKE	No. of Reels
THIRD DEGREE	Lubin	5	MAN'S ENEMY	K. & E. Biograph	3
THOR, LORD OF JUNGLE.....	Selig	3	IN TUNE WITH THE WILD.....	Selig	3
THE BATTLE OF SHILOH.....	Lubin	4	THE WOLF	Lubin	6
THE LION AND THE MOUSE.....	Lubin	6	SHADOWS OF THE PAST.....	Vitagraph	3
THROUGH FIRE TO FORTUNE.....	Lubin	5	MR. BINGLES' MELODRAMA.....	Vitagraph	3
JUDITH OF BETHULIA.....	Biograph	4	MEN AND WOMEN.....	K. & E. Biograph	3
GERMINAL	Pathe	5	THE SECRET OF THE RING.....	Kleine	3
LOST IN MID OCEAN.....	Vitagraph	3	MY FRIEND FROM INDIA.....	Edison	3
A ROMANY SPY.....	Pathe	3	LIBERTY BELLES	K. & E. Biograph	3
A CELEBRATED CASE.....	Kalem	4	THE ERRING	Lubin	3
THE FULFILLMENT	Essanay	3	AMBUSHED	Essanay	3
NIGHT RIDERS OF PETERSHAM.....	Vitagraph	3	SONG OF THE SOUL.....	Kleine	3
HARDING'S HERITAGE	Pathe	3	KIT, THE ARKANSAS TRAVELER.....	Kalem	3
DAUGHTERS OF MEN.....	Lubin	5	CHIP OF THE FLYING "U".....	Selig	3
THE OTHER HALF OF THE NOTE.....	Kalem	3	FAIR REBEL	K. & E. Biograph	3
HER LADYSHIP	Selig	3	HOUSE NEXT DOOR.....	Lubin	5
GOODNESS GRACIOUS	Vitagraph	3	MY OFFICIAL WIFE.....	Vitagraph	5
OFFICER JIM	Lubin	3	UNCLE BILL	Vitagraph	3
DEATH SIGN AT HIGH NOON.....	Kalem	3	THE FORTUNE HUNTER.....	Lubin	6
GAME OF LIFE.....	Selig	3	THE VENDETTA.....	Kleine	5
THE MILITANT SUFFRAGETTE.....	Pathe	5	BAREFOOT BOY	Kalem	3
FRANCIS MARION, "THE SWAMP FOX".....	Kalem	3	THE WIFE	K. & E. Biograph	3
A MILLION BID.....	Vitagraph	5	KING OF CHANCE.....	Kalem	3
THE FATAL WEDDING.....	K. & E. Biograph	3	THE WAGES OF SIN.....	K. & E. Biograph	3
THE GAMBLERS	Lubin	5	THE PLUM TREE.....	Essanay	3
ANNE BOLEYN	Kleine	3	THE FIFTH MAN.....	Selig	3
STRUGGLE FOR LIFE.....	Pathe	5	THE GOLDEN BEETLE.....	Kleine	4
MONGREL AND MASTER.....	Essanay	3	THE WEIGHT OF A CROWN.....	Lubin	3
THE ROYAL BOX.....	Selig	4	MARAH, THE PYTHONESS.....	Lubin	3
THE CURSE OF CREED.....	Melies	5	CHARITY BALL	K. & E. Biograph	3
FACING THE FOOTLIGHTS.....	Pathe	3	HEARTS AND MASKS.....	Selig	3
BLOOD WILL TELL.....	Essanay	3	A FLORIDA ENCHANTMENT.....	Vitagraph	5
CONQUEST OF QUEBEC.....	Kalem	5	ROAD TO YESTERDAY.....	K. & E. Biograph	3
THE LILY OF THE VALLEY.....	Selig	3	THE PAINTED WORLD.....	Vitagraph	3
CLASSMATES	K. & E. Biograph	4	JUDGE NOT	Kleine	4
MAN OF THE HOUR.....	Selig	3	GARRISON'S FINISH	Selig	3
MR. BARNES OF NEW YORK.....	Vitagraph	6	POWER OF THE PRESS.....	K. & E. Biograph	4
LOVE, LUCK AND GASOLINE.....	Vitagraph	3	IN THE GLARE OF LIGHTS.....	Essanay	3
THE BILLIONAIRE	K. & E. Biograph	3	THE RED CROSS NURSE.....	Melies	3
SPORT AND TRAVEL IN CENTRAL AFRICA	Pathe	5	THE THREADS OF DESTINY.....	Lubin	5
THE GOOD FOR NOTHING.....	Essanay	4	WHEN THE LIONS ESCAPE.....	Melies	3
THE BOER WAR.....	Kalem	5	THE GENIUS	K. & E. Biograph	3
THE THUMB PRINT.....	Melies	4	STONEWALL JACKSON'S WAY.....	Lubin	3
STRONGHEART	K. & E. Biograph	3	THE INVISIBLE POWER	Kalem	4
LORD CHUMLEY	K. & E. Biograph	4	THE WOMAN IN BLACK.....	K. & E. Biograph	4
SEVEN DAYS	K. & E. Biograph	3	UNDER THE GASLIGHT.....	K. & E. Biograph	4
TREASURE OF ABDAR RAHMAN.....	Pathe	4	"413"	Vitagraph	3
'NEATH THE LION'S PAW.....	Melies	3	THE WIN(K)SOME WIDOW.....	Vitagraph	4
ONE WONDERFUL NIGHT.....	Essanay	4	THE STORY OF THE BLOOD RED ROSE.....	Selig	3
WOMAN AGAINST WOMAN.....	K. & E. Biograph	3	THE TELL TALE HAND.....	Essanay	3
IN DEFIANCE OF LAW.....	Selig	3	A POOR RELATION.....	K. & E. Biograph	3
A KINGDOM AT STAKE.....	Kleine	3	THE LOCKED DOOR.....	Vitagraph	3
CAPTAIN ALVAREZ	Vitagraph	6	THE TANGLE	Vitagraph	4
OTHELLO	Kleine	5	THE SPY'S FATE	Lubin	3
SHANNON OF SIXTH.....	Kalem	5	IN THE DAYS OF THE THUNDERING HERD	Selig	5

Cosmofotofilm Co



London Film Co.
(Trade Mark)

"Where the REAL FEATURES Come From"
"She Stoops To Conquer"

A Classic Dramatic Comedy in 4 Parts
For Exclusive Rights, Address us at
World's Tower Bldg., 110 W. 40th St., New York



B. A. ROLFE PRESENTS
For His First Release the Well Known Classic

RIP VAN WINKLE

With **THOMAS JEFFERSON**
RELEASED NOV. 9th ALCO

TO BE FOLLOWED BY

THE THREE OF US

By Rachel Crothers
With **MISS MABEL TALIAFERRO**
RELEASED DEC. 14th ALCO

THE B. A. ROLFE PHOTO PLAYS INC. 1493 BROADWAY
NEW YORK CITY



"FLYING A" AND AMERICAN

"BEAUTY" FEATURE FILMS

"IN THE CANDLELIGHT"

In Two Acts

Featuring **VIVIAN RICH** and **WM. GARWOOD**

Under direction of Thos. Ricketts

Release Monday, Nov. 23rd, 1914

AMERICAN BEAUTY FILMS

"AS A MAN THINKETH"

(So He Is)

A Superb Psychological Drama

Release Tuesday, Nov. 24th, 1914

"THE ARCHAEOLOGIST"

A Love Drama Featuring **WINNIFRED GREENWOOD** and **ED. COXEN**

Under Direction of Henry Otto

Release Wednesday, Nov. 25th, 1914

Distributed exclusively through the United States and Canada by the Mutual Film Corporation

AMERICAN FILM MANUFACTURING

CHICAGO





THE BIGGEST PUNCH
of the season is coming

This is it:

"THE SPAN OF LIFE"

A Five Part Kinetophote Feature

with **LIONEL BARRYMORE**

Assisted by
Gladys Wynne, Lyster Chambers and others

NOT TO FORGET

THESE KINETOPHOTE RELEASES:

"THE SPIRIT OF THE POPPY"

THE GREATEST MORAL PHOTO-
PLAY EVER WRITTEN

With Edward Mackay, Edith Lockett, Anna
Rose, Nicholas Dunaew and others

"THE COMING POWER"

A GRIPPING POLITICAL STORY

With Lionel Adams, Edith Lockett, William
Crimmins and Anna Rose

and the

SPECTACLE OF THE SEASON

"MARKIA"

The \$200,000 Ambrosio Production
BOOK NOW if you want a chance at them

ALSO

"BORN AGAIN"

with **BEULAH POYNTER**

HERE ARE OUR EXCHANGES:

AMERICAN FEATURE FILM CO., 162 Tremont Street,
Boston, Mass.—Maine, New Hampshire, Vermont,
Massachusetts, Rhode Island and Connecticut—All
New England.

EASTERN BOOKING OFFICES, 1237 Vine St., Phila-
delphia, Pa.—Eastern Pennsylvania, Southern New
Jersey, Virginia, Delaware and District of Columbia.

EASTERN BOOKING OFFICES (Pittsburgh Branch,
432 Wabash Building)—Western Pennsylvania and
West Virginia.

EASTERN BOOKING OFFICES (Cleveland Branch, 218
Columbia Building)—State of Ohio.

K. C. BOOKING CO., INC. (Chicago Branch, Mallery
Bldg., S. E. Cor. Madison and Wabash Sts.)—Illinois
and Wisconsin.

ATLANTIC SERVICE CO., 508 Rhodes Building, At-
lanta, Ga.—Georgia, Alabama, North Carolina, South
Carolina, Mississippi and Florida.

CALIFORNIA FILM SERVICE CORPORATION, 1149
Mission Street, San Francisco, Cal. (with branches in
Salt Lake City, Utah, Denver, Seattle, Portland, Ore.,
and Los Angeles)—California, Oregon, Washington,
New Mexico, Montana, Idaho, Wyoming, Colorado,
Nevada, Arizona and Utah.

DAILLAS FILM CO., Dallas, Tex.—Texas, Louisiana,
Oklahoma and Arkansas.

Feature



Productions

Telephone: 6072 Bryant

126-132 West 46th Street, NEW YORK



**THE ALBUQUERQUE FILM
MFG. COMPANY, Inc.**

Featuring that clever
Comedienne

Miss Dot Farley

Two Comedies Weekly

RELEASING THROUGH
The United Motion Picture Producers, Inc.
WHO DISTRIBUTE THROUGH
Warner's Features, Inc.

By request from many exchanges
we take pleasure in
reviving the

**FRONTIER
TWIN STORIES**

Written and made famous by Miss Dot
Farley. Under direction of

Gilbert P. Hamilton

Farce Comedy Production

BY

ARCHER McMACKIN

Nuf Sed

WESTERN STUDIO

406 Court St.

Los Angeles, Calif.

GILBERT P. HAMILTON, Pres. and Gen. Mgr.

NOVEMBER 21, 1914

Accessory News

THE CONSTRUCTION, EQUIPMENT AND OPERATION OF THE MODERN PICTURE THEATRE
VOLUME X NUMBER 20

BEAUTIFY YOUR THEATRE

It is a fact that our floral decorations in lobbies and theatres have turned theatre failures into successes. We will send you a long list of pleased customers.

Don't start redecorating till you have seen the effect of our flowers and soft lights, electrical screen flowers, palms, etc.

Write for our Catalogue

The Schroeder Art Flower Mfg. Co.

6023 Superior Avenue, N. E.

Cleveland, Ohio

T S M

QUALITY

Our Specialty is in

BRASS

Theatre Lobby Frames Railings and Fixtures

T. S. M. Quality and service is what you want. Get our prices and suggestions before you place your orders.

The Theatre Specialty Mfg. Co.

318 Long Ave., Cleveland, Ohio

19
West
23d Street
New York

WE HAVE MOVED

TO THE

FIFTH AVE. BUILDING

Broadway and 23d Street

19
West
23d Street
New York

The most convenient location in New York for all exhibitors, managers and operators. Large, handsome, ground floor store; no elevators; no stairs to climb.

Mail orders our specialty Write in for anything you want in theatre supplies. Our long established reputation insures reliability. Promptest shipments.

The best of everything for the modern theatre at reasonable prices. The biggest motion picture supply house in America

Picture Theatre Equipment Company

19 West 23d Street, New York

Note our new address

Note our new address

MENGER & RING

302
W. 42nd
Street
New York

TELEPHONE
BRYANT 6621

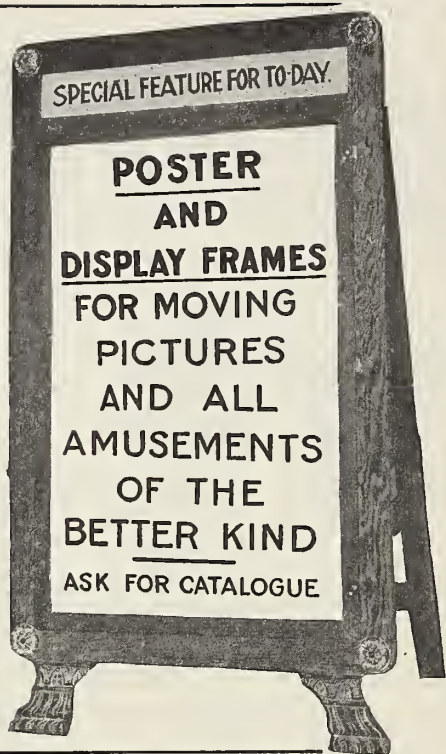

THESE LOBBY PICTURES

are hand colored. They are a work of art. They add tone to the Theatre and denote CLASS. MAKE YOUR LOBBY NEW

Blanche Sweet
Mae Marsh
Mahle Normand
Marguerite Fisher
Fred Mace
Winnifred Greenwood
Maude Fealy
Irene Hunt
Henry Walthall
Robert Harron
Norma Phillips
Florence LaBadie
Anita Stewart
Lillian Walker
John Bunny
Pearl White
Kathlyn Williams
Vivian Rich
Ed. Coxen
Roscoe Arbuckle
Grace Cunard



Francis X. Bushman
Lottie Briscoe
Mary Fuller (2 styles)
Mary Pickford (2 styles)
Crane Wilbur
Chas. Chaplin
Ford Sterling
King Baggott
Arthur Johnson
Paul Panzer
Pearl Sindelar
Warren Kerrigan
Alice Joyce
Cleo Madison
Margaret Snow
James Cruze
Dorothy Gish
Lillian Gish
Francis Ford
Ella Hall
Robert Leonard

Size 22 x 28 Inches. 75 Cents Each.
Framed, \$2.50 Each.
**The Semi-Photo Post Cards,
\$3 Per Thousand**



of over 400 players is the best souvenir extant. It will increase your business. Note our other publications. Post Cards for hand coloring. Hand Colored Post Cards.



PHOTOGRAPHS, SIZE 8 x 10, of all the prominent players, Association and Independent, 400 different names, 20 cents each.

LARGE PICTURE, semi-photo, glazed finish, size 11 x 14, \$1 per doz.; 43 prominent players.

LARGE PICTURES, HAND COLORED, size 11 x 14. Prominent players, \$2.00 per set of 12. 53 players.

Photographs for lobby display of the two and three reel features of all of the Mutual multiple reels—set of 6, \$1.00. Always ready 10 days ahead of release.

KRAUS MFG. CO., 14 E. 17th Street, N. Y.

Middle West Office—Lyric Theatre Bldg., Dayton, O.

Send for Catalogue of over 400 players and samples free. Write us giving details of your dull nights, and we will send you a remedy.

PERFUMES DISINFECTANTS

SPRAYING DISINFECTANTS.

BOUQUET, 1 gal., \$2.50; 5 gal., \$10. Our best. Cannot be equaled in strength and fragrance.

LAVENDER, 1 gal., \$2.00; 5 gal., \$7.50. REFRESHING.

SPEARMINT, 1 gal., \$1.50; 5 gal., \$5.00. POWERFUL.

PRICES INCLUDE LARGE SPRAYER.
50 cent. credit without sprayer.

PERFUMES.

Can be used with Fans or in Clay or Plaster Paris Cones.

Cinnamon	\$2.50	
Spearmint	3.50	CONES 30 cents
Lavender	3.50	each.
Carnation	6.00	
Bouquet	6.00	

YOUR MONEY REFUNDED IF NOT SATISFACTORY

We sold the first perfumed disinfectants in this country, and on account of manufacturing and importing direct, the quality at our price cannot be beat.

GENDISCO

408 36th Street - BROOKLYN, N. Y.

10% May be deducted from above prices on any order no matter how large if check is sent together with this Coupon.

Offer only good up to January 1, 1915

Please send me the following.....

.....

.....

.....

.....

Less discount of 10%.

Name..... Theatre.....

Address

MADE
IN
AMERICA

36 1-9 c.
A SQ. FT.

MIRROROIDE

The World's Best Screen

OVER 8000

IN USE THE WORLD OVER

USED THE
WORLD
OVER

\$3.25
A SQ. YD.

Send for our large free samples—test—any way you desire. Use the eyes God Gave You. Mirroide is guaranteed for five years against cracking—peeling—or deteriorating. You can wash it with soap and water. The only screen on earth sold under a Bon-i-Fide Guarantee.

THE J. H. GENTER CO., Inc.

NEWBURGH, N. Y.

Other products—Pure White Curtain Coating, Metallic Lacquers, Incandescent Lamp Dip Colors and Ready to Use Bronzes. Any Metal or Colors.

SILVER WHITE
OR
SILVER FLESH
OR
PALE GOLD

MIRROROIDE EVENTUALLY

MATTE
FINISH

Construction,
Equipment,
Operation

Accessory News

Everything for
the Modern
Picture Theatre

Tel. 7850 Bryant

NO. 220 WEST FORTY-SECOND STREET

New York City

Volume X

NOVEMBER 21, 1914

Number 20

Modern Achievement in Lobby Fixtures

Adequate Lobby Display is a Vital Feature of Every Theatre—The Output of Several Companies, Here Described, is Indicative of the Opportunities an Exhibitor Has With the Styles and Varieties Now at His Command

(Editor's Note.—Any information as to where to purchase particular styles of frames or other lobby display accessories may be had through our Buyers' Service Department.)

AMONG present day exhibitors there is a class, though getting smaller every day, that still persists in keeping behind the times in regard to lobby displays and proper showing of posters of their current and coming programs. Why in these days of progress and invention an exhibitor should stick in the same

also made in the following finishes which do not have to be polished: burnished brass, brass oxidized, gun metal, brushed or dull brass, german silver, statuary bronze and oxidized.

A patent clip which clamps the poster firmly to the backboard is furnished gratis with all 3-sheet and 6-sheet poster frames. The posters by the use of these clips are quickly attached without using any thumbtacks, and hold fast so that the wind will not tear the poster when no glass is used.

In the following article with the aid of a few cuts, will be made clear how by the proper use of poster-frames and fixtures, an exhibitor can display his posters to best advantage, either in his lobby or in front of his theatre.

How many times is a beautiful marble front or lobby spoiled as far as appearances go by indiscriminate pasting or otherwise covering up with posters and advertising matter! It is all right to paste posters on fences or on the fronts of unoccupied or untenanted buildings, but banish the pastepot from the front or lobbies of theatres.

There are frames and easels for one sheets, and these frames are also made with hooks so they can be hung along the wall, on a long rod running along the wall, at about the height of the average picture molding.

If desired a sign on top of the frames composed of the letters, spelling "COMING," "TODAY," "TOMORROW," and so on, is furnished at a slight additional cost.

The backs are of non-warpable comboard, hinged to the frame in such a manner as to make the insertion

of the poster an easy matter. Once inserted, it is secure. These frames are also made in large sizes for the accommodation of three and even six sheet posters, with or without glass fronts. There are also frames for two, three, or four one sheets, or two one sheets and one three sheet. In fact, if the combination desired cannot be found in the catalog, you can have it made to your own order.

These large frames, using the six sheets for example, are made very strong and substantial, with the comboard backing entirely removable. The poster is held tightly to the backing by twenty-four locking clip attachments, as may be seen from the cut. These are furnished without glass and with two brass legs on the bottom to raise the frame slightly off the ground.



A DOUBLE ONE-SHEET EASEL FRAME (Newman)

old rut and think that, as long as he has given proper attention to the interior of his theatre, looked after the comfort of his patrons in various ways, put on a good show, why he should stop there and not pay any attention to the front of his theatre, is beyond comprehension.

The time has arrived when exhibitors and managers of show houses must make an attractive lobby display and give as much attention to the front of their houses as they do to the booking of their show and the comfort of their audiences.

There are now on the market various forms of poster frames large and small, easels, and so forth, in so many different styles that it should be easy for one to take a catalogue of any of the various firms advertising in ACCESSORY NEWS and pick out the style or styles best suited to his type of theatre front.

Goods That Are "Use-Proof"

The modern lobby frames are made to withstand the roughest usage. Heavy sheet brass is drawn through a die together with a wood-moulding in such a manner that the brass is clinched to the wood so that it is practically one solid piece, with no sharp edges to cut the hand when cleaning or polishing frames.

Besides being finished in polished brass, the lobby frames are



One-Sheet Poster Frame (Levy)

Strong hooks can be substituted instead of legs so as to hang the frame over the lobby or entrance, or easel legs can be attached for back tilting.

The Interchangeable Tile Letter Sign.

Another frame that could be used to advantage at the entrance or side of the lobby is the "Interchangeable Tile-Letter Sign."

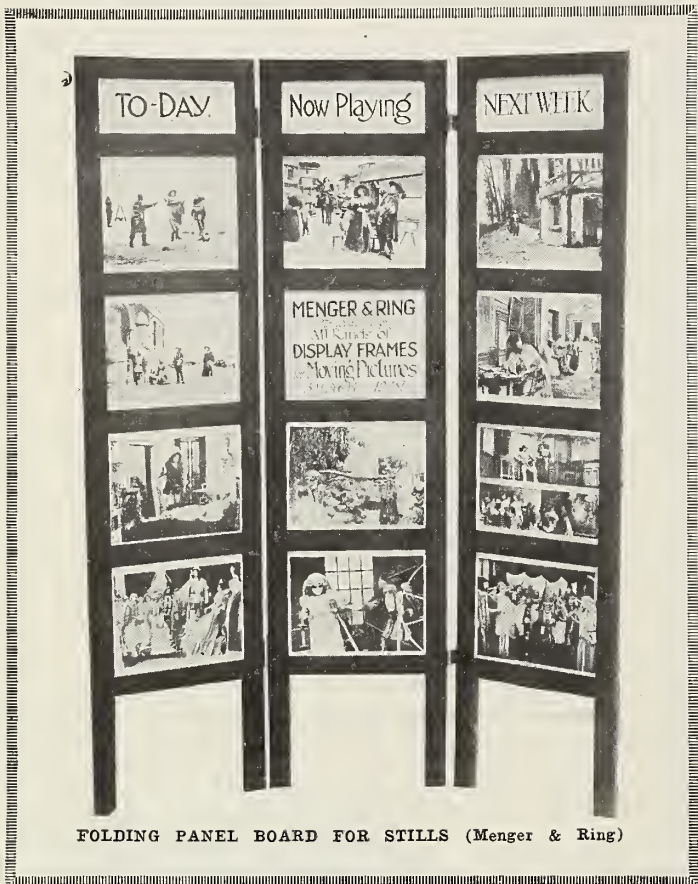

FOLDING PANEL BOARD FOR STILLS (Menger & Ring)

These letters are black on highly glazed white tile blocks, and are easily inserted by sliding into grooves at one end of the board. Announcements can be easily changed. The frame, which can be set on easel or hung from hand rail or on wall, has a locking attachment to prevent the theft of letters.



SIX-SHEET POSTER FRAME (Newman)

The top sign, "Today," shown in cut, is also of tile letters set in a cast brass frame and any other wording up to but not exceeding eight letters, can be substituted.

Another style of poster-frame used by many exhibitors, and in

some cases preferred to the metal frames, is the frame made of wood, painted and finished to harmonize with the surroundings.

These frames can be had from the exhibitor's own design or chosen from various designs from the catalogues of the different manufacturers. They will stand all manner of rough usage and are really more fitting in some lobbies than the metal frames.

Many beautiful designs, some of them very elaborately carved, are on exhibition about first-class houses, and everywhere they are enthusiastically recommended.

In this article there are shown examples of some of the most generally used wooden frames, and a letter to the manufacturer will bring many other varied and beautiful designs.

Another article which will fill a long-felt want for the exhibitor who is handicapped for space is the "combination portable brass ticket booth and poster displayer." This booth is furnished complete with brass grille, brass money shelf and cash drawer. It is made entirely of brass with moulding all around and twenty-one electric sockets along the top projecting brass cornice.

In the front a one-sheet poster compartment is provided with an additional compartment on either side of it for the insertion of cards or announcements. On each side of the booth is a compartment for a three-sheet poster, and in the back are spaces for various size posters, and in this manner an attractive lobby display can be had without losing any valuable space.

The booth is made so that the sides can be folded together, and the booth moved to the wall-out of the way at any time.

The size of this booth is 42 inches wide, 42 inches deep and 86 inches high.

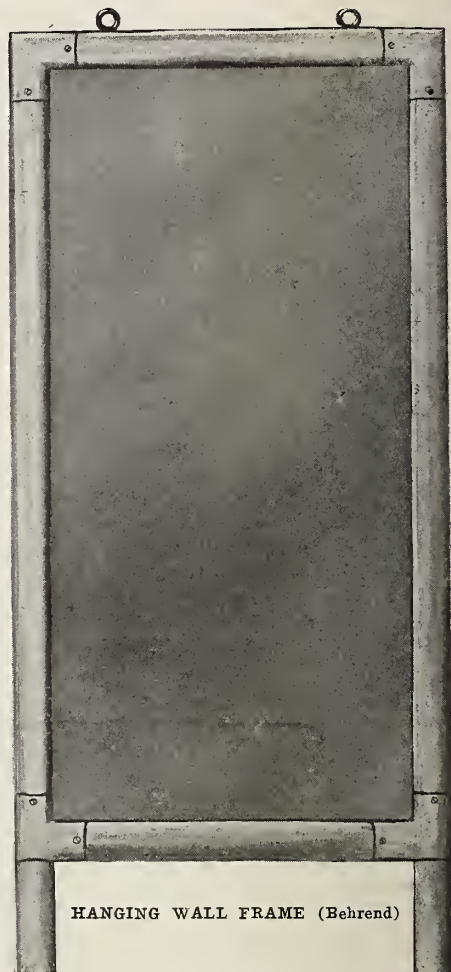

HANGING WALL FRAME (Behrend)

New Wall Covering

Williams, Brown & Earle, 918 Chestnut street, Philadelphia, have recently brought out a new compound for spraying the walls of motion picture theatres.

This compound is intended to be put on the white wall as a finish upon which to project pictures. It is claimed by the manufacturers that the resultant effect is agreeable and that the picture produced is brilliant. The principle of this wash covering is not new and this particular compound is said to be satisfactory.

Novel Slides for Thanksgiving

For Thanksgiving Day an excellent series of attractive slides has been prepared by the Novelty Slide Company, of 67 West Twenty-third street, New York. There is a variety of Thanksgiving Day greeting slides, and an assortment of clever advertising slides with appropriate designs and suitable illustrations for the holiday.

A new pamphlet has just been issued, illustrating these various slides and will be mailed to exhibitors upon request.

Projection

EDITOR'S NOTE.—Mr. Herbert W. Andem, whose articles and answers to questions will appear every week in the "Projection" Department, has just recently been chief examiner of motion picture operators for the City of New York. Previous to this, he was assistant examiner, and had been connected with the City Department of Water, Gas, and Electricity for some time. Mr. Andem's practical experience with projection machines dates back to 1894. From this date on he operated all makes of machines up to 1900, since which time he has acted as a projection expert and electrical engineer, covering a wide and detailed field of work.

Is It the Novelty Only in Motion Pictures That Now Attracts an Audience?

BY HERBERT S. ANDEM

FIFTEEN years, yes, you may say eighteen years ago, the wonder of animated pictures was sufficient to attract. The spectator was not concerned in the picture he was to see. He was anxious to see an exhibition of anything the exhibitor had to show him.

He wanted to see and be convinced that motion picture photography had been discovered as stated in newspapers and publications throughout the country. This fact only was uppermost in the public mind. There was an invention to be seen. The exhibition could be given in most any place. A vacant store, improvised for the occasion and some announcement signs displayed in any but an attractive manner, and you had an audience waiting to see the latest wonder of the twentieth century.

The exhibition would last about twenty minutes to one half hour. The films were made only in fifty-foot lengths. In about twenty seconds this short length of film would have been projected on the screen. This fractional part of a minute was too short a space of time to satisfy the audience with one subject, or scene, and, to facilitate also in the operation of the machine, these fifty-foot lengths of film were joined end to end in belt fashion. This belt of film was then threaded over rollers on a "spool bank." In this manner the subjects could be repeated any number of times. Repeating the scene a second time was the practice.

The Pictures of the Early Days

The subjects shown! What were they? One of the earliest, and a very popular subject, too, was a scene purporting to be in a barber shop. In reality, it was a made-up scene in the first kinetographic theatre erected for this special use in taking of animated pictures at the Edison laboratory.

This theatre building was popularly dubbed the "Black Maria" from the weird appearance of this revolving building. By watching very closely one could see a man being shaved in the barber chair. Another man was having his shoes blackened. While this was going on he was seen smoking a cigar.

The rising smoke from the "puffs" at the cigar created more wonder and excitement than anything else in the picture. It was wonderful! The reproduction of motion to the people was conceivable to one's mind. But the reproduction of smoke, in motion, was a step beyond the conceivable.

What would happen, if today, this same film should be reproduced in any of the numerous theatres? Just imagine for the moment the scope of action portrayed in this scene. The motion of the arms and hands of the barber lathering and shaving a customer! Or, the motion of the bootblack's arm polishing shoes! Could you exhibitors of today hold an audience within a theatre for a longer time than the fifteen seconds it takes to reproduce this season? You certainly could not.

After most two decades have passed since the Lumiere Cinematographe and the Vitascope appeared to the public, this public today has been educated from the wonder of this invention to the entertainment only to be derived from varied scenes shown on

the screen. This entertainment is the only element that now attracts an audience.

The exhibitor to be successful must please his audience. This has never been different. There is this difference in pleasing an audience of today, however, that you have to give them a good show without the element of the wonder of motion picture photography playing a part in the attraction.

Only First-Class Film Can be Used

New material must be given. This means, films that are too much worn, or those that have scratches from long use of the film going repeatedly through projection machines, cannot be used. It is poor economy to exhibit films in this condition. The audience does not know the cause for this appearance in the picture on the screen. It has been described as rain effect, or "rain pictures," which is quite expressive. At any rate, the audience takes notice of it and knows that something must be wrong. They do not see it in all pictures and they will soon discover the reason.

The next important step is to give only good work on the screen. A good motion picture machine is the *all* important thing. Starting with a good machine, it should then be firmly anchored in a manner to absolutely prevent any motion or vibration to the picture on the screen from the work of the operator in turning the crank, putting in of lantern slides, or pushing the arc lamp into position for operating.

Nothing disturbs the vision of an audience as much as this movement of the picture. For the best results in pleasing an audience it also means to have a good operator in the booth. Here is another false economy for the exhibitor paying low wages to the operating help and securing only mediocre operators. Good operators cannot be retained long at small wages. The two star actors at your show are the projection machine and its operator.

Star actors in other classes of theatricals demand first attention and obtain the best in salaries. Why not give these stars of the motion picture theatre their just due in respect to attention and to money? Pay the money for good material in these two places and watch the increased box office receipts.

Next to the annoyance of seeing a picture on the screen shaking as if it had a "chill," is the everlasting trying, on the part of a poor operator, to obtain a sharp focus to the picture being shown. He is turning the adjustment for the focussing back and forth to a greater degree than is necessary for careful work.

The picture blurs unnecessarily and the eyes of the audience alter in sympathy with it. This blurring of the picture causes additional eye strain to the spectators. The eye is already strained from the necessary intermittent motion, or succession, of the individual pictures.

Good Selection the Exhibitor's Duty

Selection of a program having a varied character, as to film subjects, is a topic to which the exhibitor must pay much attention. There are photoplay films, in two or more reel features, in great numbers from which a program may be selected. In fact, there are so many of these photoplay titles marketed, when compared to other classes of subjects, these are almost forgotten.

To give a show containing only photoplay films, varying the program by titles as to whether it is tragic, humorous or emotional, does not satisfy completely. In the other classes of houses, namely, vaudeville and theatre of varieties, a program having *all* the acts of a similar character, viz., one-act playlet, singing, instrumental, monologue, or gymnastic, would soon bring failure.

A varied bill, no two acts similar in character, which is the general run of a program in this class of house, satisfies an audience. This audience, having once been amused and pleased, wants more.

Some exhibitors, outside of New York City, have already awakened to the fact that the novelty in motion pictures does not now attract an audience and are following a policy of giving a well selected and varied program.

A theatre in Montclair, N. J., has adopted such a plan. The

(Continued on page 75.)

Cosmofotofilm Co



London Film Co.
(Trade Mark)

“Where the REAL FEATURES Come From”
“For Home and Country”

A GREAT WAR SUBJECT FULL OF ACTION 2 PARTS
 For Exclusive Rights, Address us at

World's Tower Bldg., 110 W. 40th St., New York

A clear picture
 is as essential as a good
 scenario. Because the
 basic product is right
 the clearest pictures are
 on Eastman Film. Ident-
 ifiable by the stencil
 mark in the margin.

EASTMAN KODAK CO.,
 ROCHESTER, N. Y.

REBUILT MACHINES

We have on hand at all times a number of REBUILT MACHINES.
 All in first class order.

Powers' No. 5 Complete with Fire Shutter.....	\$75.00
Edison Exhibition, one pin movement	65.00
1911 Motiograph, complete	110.00
1912 Motiograph, complete	125.00
Powers' No. 6, complete	125.00
Powers' No. 6, with 1912 Motiograph Lamp House.....	135.00

A-1 condition guaranteed.
 Will sell for CASH or on EASY PAYMENTS.
 Write for new catalog just off the press.

AMUSEMENT SUPPLY COMPANY
 160 No. Fifth Ave., Chicago, Ill.

MOVING PICTURE THEATRE MAILING LISTS FOR SALE

20,192, covering United States and Canada, Price \$40.00, or
 \$3.50 per thousand for such states as you want.

795 Film Exchanges, U. S.	\$3.50
70 Manufacturers and Studios, U. S.....	1.00
34 Moving Picture Machine Mfrs. and Dealers.....	1.00
231 Film Exchanges, Foreign Countries.....	3.00
520 Moving Picture Theatres, Foreign Countries....	3.00

Ask us for full particulars.

TRADE CIRCULAR ADDRESSING CO.
 166 West Adams Street, Chicago
 Established 1880

MOTIOGRAPH
FLICKERLESS PROJECTOR

MOTIOGRAPH SATISFACTION

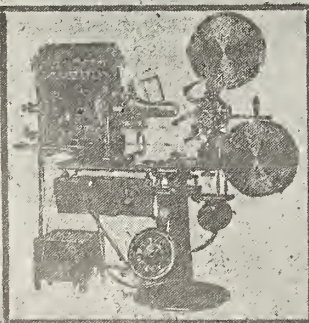

MOTIOGRAPH SIMPLICITY

SMALL UP-KEEP

Are you interested in knowing how to keep
 from buying repairs for your motion picture
 machine? One word answers the question—

MOTIOGRAPH

Install a Motiograph and your repair bills stop. We
 have proof. Write for catalogue and get the facts.

THE ENTERPRISE OPTICAL MFG. CO.

568 W. Randolph St., Chicago, Ill.

Eastern Office
 21 E. 14th St., New York

Western Office
 33 Market St., San Francisco

SAVE 35%

on your

CARBONS

Burn your stubs with a

CARBON Economizer



Pat. applied for.

Fits any lamp, gives perfect contact and conductivity made of special material, screw does not come in contact with carbon and will not weld to body of economizer; will burn upper or lower carbon to 3/4 of an inch.

"MECHANICALLY CORRECT"!!

Guaranteed to give satisfaction

\$1.25 Sizes \$2.00
Each. 1/2"-5/8"-3/4" Set—any sizes.

Sent postpaid upon receipt of New York Draft, Money Order or Cash.

THE CARBON ECONOMIZER CO.

757 W. Onondaga St., Syracuse, N. Y.

Corcoran Tank System

Is a Money Saver

Get Price List No. 6

A. J. CORCORAN, Inc.

9 1/2 John Street New York

LANG'S FILM REELS

THE BEST MADE

14 in. \$1.50 12 in. \$1.25 10 in. \$1.00

CATALOGUE

LANG MFG WORKS, Olean, N. Y.

TESTIMONIALS PROVE remarkable results in the way of increased business, by using our system to advertise your daily program in advance. Our price for any service is 75c. A WEEK.

Write for circular and a sample slide of your own wording.

CUT-OUT SLIDE CO., Emerson Tower Bldg., Baltimore, Md.

Our Factory Is Yours!

Negative assemblers, projecting machines and an equipment second to none, with an organization of experienced people always at your SERVICE for DEVELOPING and PRINTING.

EVANS FILM MFG. CO.

Incorporated

416-22 WEST 216th STREET

Tel. 7652 Audubon at Broadway, New York

PROJECTION

(Continued from page 73.)

program says, "We are giving you the best and solicit your patronage." This theatre is doing as it says. All success to this exhibitor. He will succeed.

Some Mistaken Ideas Regarding Dynamos

BY H. S. ANDEM

"**H**OW much current does this dynamo generate?"

One hears this question asked very frequently. Many operators, no doubt, would ask this question themselves when visiting some generating station and think it perfectly correct. Motion picture machine operators pride themselves on their knowledge of electricity. Can many of them see the technical error in expressing the question of a size of a dynamo by asking: "How much current does it generate?"

A dynamo does not generate current. Then does a dynamo generate electricity? No. A dynamo does not even generate electricity, though this, too, is another familiar expression.

Before answering what does a dynamo generate let us consider two parallel cases of machines known longer in this world than dynamos. A pump is used to force water through a pipe, The pump does not generate water. It merely generates pressure to the water, and causes the water to flow out over any path it may find of the least resistance back to the level of its supply, or to the centre of the earth if it can find such a path.

A blower is caused to revolve at a high velocity for producing a blast of air. But this blower does not generate air. It generates, or produces, pressure to the air only and the air flows through any outlet it may find, until the pressure the blower imparted to the air is spent in overcoming resistance.

A dynamo acts similarly. It generates electrical pressure. This pressure then causes a current of electricity to flow over any path it finds, seeking one of the least resistance. The more lights, motors and other electrical devices connected across the wires from the armature the less resistance is offered to the electrical pressure, generated and the greater the current becomes until the strength of current flowing is so great that the wires on the armature get hot.

This heating of the armature determines its capacity for work. The larger the dynamo the larger the wires that may be placed on the armature and the larger the current it will stand before heating.

This is how the question "How much current does this dynamo generate?" originated, meaning, as we now see, how much current does this dynamo carry, or allow to flow through it, before the armature gets too hot?

Dynamos generate electrical pressure only. Currents cannot exist by themselves. Currents result from pressure overcoming resistances. If there be no pressure there cannot be current. And if there is pressure and a resistance equal to, or greater, than this pressure acting against it, no electrical current can exist either. Pressure only is present.

The Renfax System and Its Use

M. T. asks: I am an experienced operator but I never had an opportunity to handle a talking picture machine. Will you let me know if the Renfax system is very complicated. I think my boss is crazy about it and is just trying to make arrangements with the Renfax people to have their device installed in our theatre at once.

Answer: You must not be frightened by any talking picture system and especially the Renfax which, in my opinion, is the simplest of all. The two figures given below, together with several technical explanations and a confidential visit to the company at 110 West Fortieth street, will put you right. Don't forget to ask for Alfred E. Gold, the chief mechanic, who understands his business and know how to make himself clear to others. If you tell him that I sent you there you will no doubt get the best treatment and enjoy your visit.

WE WANT CAMERA MEN

Who have their own Outfits and can Prove Reliability to write us at once.

INDUSTRIAL MOVING PICTURE CO.
223 West Erie Street CHICAGO

Be sure to mention "ACCESSORY NEWS" when writing to advertisers.



True to Quality Slides

THANKSGIVING DAY SLIDES

Stock Announcements25c.

Advertising Slides, with appropriate design and illustration75c.

ADVANCE SLIDES

for every feature picture and

PHOTO PLAYER SLIDES

Players of all companies 25c. each, postpaid

WAR SLIDES

direct from European battlefields

Write for Catalog N

NOVELTY SLIDE CO.

67 West 23d St., New York

CAMERAS WANTED

Will purchase several second hand motion picture cameras. Must be in good condition. Write at once to

Charles Reid, Millersburg, Pa.



Prices to the Trade
POSITIVE PRINTS .04 1/2 Per Foot
(In Quantities over 5000 feet)

Above price includes printing, developing, tinting, toning and Raw Positive.

Negative Film Developed .01 Per Ft.

Film Titles .08 " "

(Our Special Title Apparatus will match any perforation.) All work guaranteed.

General Offices, 2674 Milwaukee Ave., Chicago
Phone Albany 3125

COMPENSARC

That's the device that saves Moving Picture men two-thirds on their electric light bills, and yet gives better light. Did you see our ad last week? Well, don't look it up. Just write for our

Booklet 5027

FORT WAYNE ELECTRIC WORKS

OF GENERAL ELECTRIC CO.
1704 BROADWAY
FORT WAYNE, INDIANA 733

Projection

The two drawings, Figure 7 and Figure 8, which represent the whole device, give an idea of how simple it is and how easily the system can be worked in conjunction with any projector. Letter *O* is a contact maker of the same type as *N* and is fixed to the spindle rotated by the handle, which operates the projector.

Bearing on each side are two springs O^1 mounted on blocks O^2 of insulating material and having terminals O^3 for the necessary electrical connections.

The contact is established so that when the handle of the projector is rotated it controls the number of times per second that the electro-magnet is energized.

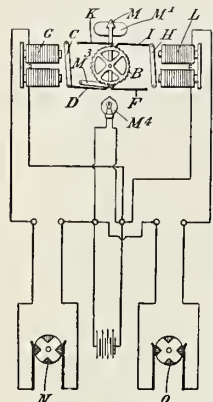

THE RENFAX SYNCHRONIZER

Figure 8 gives a broader idea of the apparatus and its connections than Figure 7 which is only a partial view showing the connections with the handle of the projector. As the contact makes *N* and *O* rotate their respective electro-magnets *G* and *L* become energized whenever a connection is made with the battery through their respective contact makers, and this takes place with the form of contact maker shown in the drawing, four times in every revolution.

As the armature *C* of the electro-magnet *G* for example is attracted, the pawl *D* attached thereto passes over a tooth on the ratchet wheel *B*. When the armature *C* is released owing to the action of the spring *E* the ratchet wheel is rotated through a distance corresponding to one tooth. The same operation takes place with the armature *H* of electro-magnet *L* when the latter is energized. If the speed of the contact makers *N* and *O* are alike, the armatures operated by their respective electro-magnets will rotate the ratchet wheel *B*, but will not move it longitudinally.

However, if the kinematograph or projector is being operated at too high speed, its contact maker will make a higher number of revolutions and consequently make electrical connection more frequently than the corresponding contact maker on the phonograph or talking machine. The result of this will be that the armature *H* will move its pawl *I* more frequently than the armature *C* moves its pawl *D*, and the ratchet wheel receiving a greater number of thrusts at one side than it does at the other will be moved in a longitudinal direction.

When this takes place the pointer *M* attached to the spindle of the ratchet wheel will move so that one or the other half, M^1 or M^2 , of the transparent screen will appear in front of the illuminated circle to the operator, according

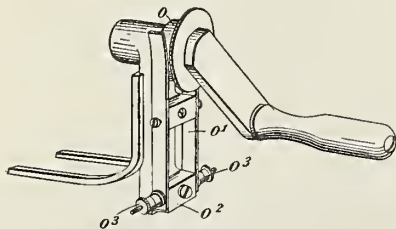

THE COMMUTATOR AND CRANK

on the electric lamp, thereby indicating

to whichever color is assigned to the projector or kinematograph, that such kinematograph is being worked too quickly.

If the operator then lowers the speed of operation of the kinematograph and allows the talking machine to increase its speed slightly, the ratchet wheel will be moved back to its proper position owing to the action of the pawl *D* moving the ratchet wheel *B* against the pawl *K*.

The above description and drawings are rather primitive as the apparatus now distributed by the Renfax company has been greatly improved, and I should add that Alfred E. Gold is constantly improving the apparatus which, as it already is, must be considered the simplest and most reliable talking picture machine to be found on the market. Therefore we think that you will have no trouble in making yourself familiar with the apparatus should your employer finally decide to get you one.

The Importance of Cleansing Lenses

THE importance of keeping all the lenses of a motion picture machine absolutely clean cannot be too firmly impressed on operators' minds. By this caution it is not meant to blow one's breath on the glass and then polish with a handkerchief, even if this handkerchief be a clean one.

However, an old cambric handkerchief that has been laundered several times will answer. But still better for this use is a piece of unglazed tissue paper. Dust off the outer surfaces of the lenses with a good camel's hair brush kept for this use only. Then wipe off the lense with the tissue paper giving a revolving motion to the hand.

Paper has a marked property toward glass, cleansing it and producing a high polish. Paper has been recommended for a long period for use in cleansing window glass. It is also an excellent cleanser for nickel plated surfaces.

The outer surfaces of the lenses ought to be cleansed in the above manner frequently. Especially the surface of the condensing lenses next to the arc lamp, *i. e.*, within the lamp house, to free the carbon dust particles having deposited on it. Each day before starting to operate is not too frequent to cleanse this surface of the condensing lenses. Also the surface of the projecting lense, next the film, needs frequent attention of an operator who takes an intelligent interest in his work.

If these surfaces of the lenses are not kept clean and bright, some of the light is lost.

Any smoky appearance on the lense had best be removed immediately. Light will be absorbed by it as also will some of the light be reflected back in all directions and be lost.

The inner surfaces of the lenses will not require so frequent cleansing. When these do have to be cleansed great care should be used and not disarrange the relative position of the several single lenses.

If any one lense is not replaced exactly as it was originally the focus and correct definition of the lense will be very much impaired.

Manufacturers of the Wonderful
Rembusch Patented Glass MIRROR SCREEN
and all other kinds of
Curtains for Moving Picture Projection

GLASS SCREENS
Mirror Screen
Mirror Screen Split
Glass Transparent Screen
for Rear Projection

Phone Seven-Eleven

METALLIZED SCREENS
Gold Fibre
Silvercloth
Mirror Cloth
Seamless, with stretchers
White Opaque

F. J. REMBUSCH, Pres.

MIRROR SCREEN COMPANY

Incorporated

SHELBYVILLE, INDIANA

Mr. O. P. Sammons of Denison, Texas, bought a "Mirror Screen," and he writes that he cannot take care of the crowds. His picture is simply the talk of the community. A few second-hand screens for sale cheap.

Eastern Representative, Frank Manning, 125 W. 48th St., N. Y. Phone, Bryant 2416.

Building and Furnishings

"The Theatre That Is Different"

OF the 300 or more motion picture houses in Philadelphia none is more unique in appearance than the little Belvidere, situated on Germantown avenue near Graver's Lane, Chestnut Hill, one of the beautiful suburbs of the Quaker City. This being one of the oldest parts of the city, it is filled with many points of interest.

Colonial architecture is the prevailing note in these quaint old structures, and into this atmosphere the Belvidere, designed by Sauer and Hahn, of Philadelphia, fits as though it too were of "ye olden tymes," instead of being erected in this year of grace, 1914. Built of red brick and black headers with buff facings and wrought iron fittings, strictly colonial in line and feeling, the theatre looks like a dignified old mansion, devoted to good cheer and hospitality. Its wrought iron lanterns, while giving all necessary light, add to this illusion, and only the attractive posters announcing the daily program proclaim to the passerby that this is in reality a motion picture house catering to his pleasure and earnestly desiring his patronage.

The interior is as harmonious and artistic as the exterior. There is an attractive little lobby with flooring of red tile. In one corner is the neat and unassuming ticket office; in the other, with entrance inside, a complete retiring room for ladies and children.

On entering one sees the ample space devoted to standing room, and is then attracted to the unusual lighting; although the performance is going on, there is perfect darkness for the pictures, and yet not the darkness one usually finds in all playhouses. Another long look and the reason for this becomes evident.

Four large indirect colonial lamps shed a green glow over the house. This arrangement gives the comfort of finding one's way about with perfect ease and yet in no wise detracting from the proper projection or lighting of the pictures.



EXTERIOR OF THE BELVIDERE THEATRE

The Adam brothers' interior shows white walls with panels, the hangings rich green as are the chairs, the fittings all wrought iron.

There are only 315 seats, but already this is found too small, and the owner, Thomas Dixon, has consulted Sauer and Hahn about the enlargement of the theatre without destroying its harmony.

For this little playhouse Colonial was the name deemed most

fitting, but this having already been pre-empted, Mr. Dixon chose the Belvidere as being euphonious and dignified.

There is a daily change of program, with only Wednesday and Saturday matinees. The prices are ten and twenty cents. A Mary Pickford play is given weekly, as also other Famous Players productions.

Although but recently completed, the Belvidere has gained in a short time a firm hold in its locality and the surrounding country. Not only is it attracting the natives or local contingent from

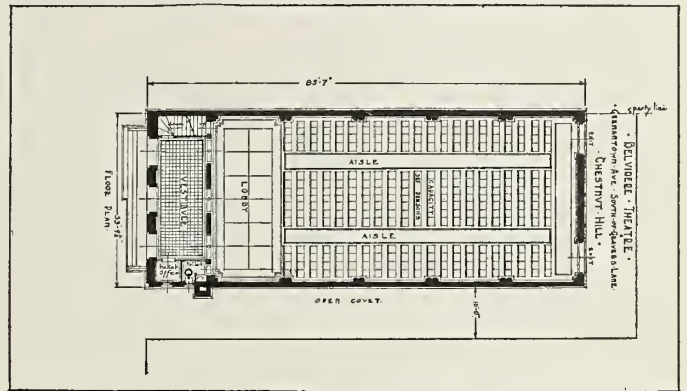

FLOOR PLAN OF THE BELVIDERE THEATRE, CHESTNUT HILL, PHILADELPHIA

Chestnut Hill and thereabout, but the "society" folk in the vicinity are coming in goodly numbers.

On Thursday nights, which the smart set for some occult reason has made its own, it is quite the fad to take in the Belvidere attractions. The string of motor cars stretches for blocks, and the brilliant evening gowns of the women, with the sober background of the "claw hammered" men, give the little Belvidere as gala an appearance as an opera night "downtown."

So noticeable has this patronage become that a society writer of one of Philadelphia's leading dailies commented on it recently in her columns. One thing of which the owner and architects are equally proud is the fact that Carl Pierce, Bosworth's well-known representative, having heard of the Belvidere "way out West," made a point, during his recent stay in Philadelphia, of visiting this "different theatre."

IRENE PAGE SOLOMON.

1500 Seat Theatre in Wisconsin Town

P. J. HANSON and Harvey Hanson, proprietors of the Palace Theatre, Antigo, Wis., will begin the erection next spring of a new photoplay theatre 185x44 feet in dimensions, with a seating capacity of at least 1,500 people.

There will be two balconies, and box seats will be arranged on either side. The seats will be upholstered, and be placed a sufficient distance apart to enable patrons to leave them without disturbing those in the adjoining ones. A pipe organ is to be installed. A site for the theatre has been purchased at an approximate cost of \$11,000.

New Lobby Frame on the Market

A NEW design for lobby display frame has just been put on the market by Menger and Ring.

This particular design is most attractive. The general effect is brown and gold with a blue ribbon effect across the top, on which will be printed the name of the theatre.

The general appearance is one of absolute neatness and it will be a great addition to their already large stock of attractive frames.

Directory of New Theatres

EDITOR'S NOTE.—The information contained in the "Directory of New Theatres" is gathered by the field representatives of "Motion Picture News" and the facts and figures in each instance have been verified by them and are authentic. They may be relied upon by members of the trade.

Dozen Theatres Are Being Erected in Detroit

THAT the motion picture industry is growing by leaps and bounds, as far as Detroit is concerned, is proven by the fact that there are today at least a dozen houses in course of erection, several big ones being contemplated, to say nothing of quite a number that have been completed this past summer.

First, there is the Alhambra, a theatre seating 1,500 that is about ready to open at the corner of Woodward and Kenilworth avenues. It is owned by the Casino Amusement Company, of which John H. Kunsky is president. This house is costing in the neighborhood of a hundred thousand dollars; it will have many new features, and predictions are that it will be among the finest picture houses in the middle west. T. D. Moule, formerly manager of the Liberty, will have charge of the Alhambra. He told a representative of *MOTION PICTURE NEWS* that the house will be ready to open not later than Saturday, November 14.

Another new house that will seat 1,850 people, all on the ground floor, is in course of erection at the corner of Woodward and Willis avenues. Harry Goldstein, the secretary and general manager, says that it will be the largest picture house in the country having all its seats on one floor. There will be no balcony. There will be a lobby capable of holding 1,500 people.

Will Show Features Only

It will be an exclusive picture house, showing high-class features only. It has a frontage of 122 feet on Woodward avenue, and runs back 176 feet. There will be four stories on the Woodward avenue front. The building will be of steel and terra cotta, and fireproof insofar as it is possible to make it. It will have 20 exits.

Among the features of the house will be an electric fountain, auto boxes, huge pipe organ and smoking room. In fact, Mr. Goldstein says it will have features that no other house in the country has ever had. He expects to have his theatre in operation by the middle of January.

Then there is the new Knickerbocker Theatre on Jefferson avenue, east of the Belle Isle bridge approach, being erected by the Ingersoll-Gaukler Company. It will seat 1,000 people, will cost \$70,000, and will be completed by May, 1915.

The Maxime Theatre, on Mack avenue, being erected by A. Arthur Caille, is about completed, and will seat about 1,000. It will open within sixty days.

More Than 125 Theatres in Detroit

Fuller Claflin has let contracts for a house seating 1,500 people, to be erected on the Grand Boulevard by the Boulevard Theatre Company. The house will be on the duplex style, being the first in the United States of its kind.

These are only a few of the dozen that are being put up in Detroit. And still occasionally one hears the remark: "Is the moving picture business going to last?" It is a fact that there are less transfers in the moving picture business, that is the buying and selling of theatres in Detroit, than in any other line of trade.

Men who own houses in Detroit are making money, despite the fact that there are more than 125 in operation. It proves beyond all doubt that the patronage at the movie houses is constantly increasing, and that new patrons are being created every day.

Messrs. Gillingham & Smith, of Grand Rapids, Mich., have secured a long lease on the property at 210-218 Monroe avenue, now occupied by the Star Clothing Company, and as soon as the present tenant vacates, which will be April 1, 1915, work will start on a high class moving picture theatre, seating around 1,800, to be known as the Strand.

Plans for Detroit Strand Complete

Plans for the new Strand Theatre on Jefferson avenue, Detroit, are completed, but the actual construction work has been put off until the spring. Mr. John Kunsky, who will erect this new playhouse, feels that he will have "his hands full" with the Alhambra and the Washington this winter and that spring will be a better time to begin work on the Strand. In this connection, it might be said, Mr. Kunsky is very well satisfied with the way business is coming at the Washington; the patronage is increasing week by week, indicating that the house is becoming known.

C. A. Scheffler plans to erect a \$6,000 picture theatre on West Fulton street, Grand Rapids, Mich.

Morgan W. Jopling, of Marquette, Mich., has ordered six motion picture machines which will be used in the theatres owned by the Delft Theatre Company in Escanaba, Marquette and Munising.

Patriotism Re-opens Calgary Theatre

ANOTHER picture theatre has been opened in Calgary and, although it is not a new one, it is being operated for a new cause. The cause is patriotism. The Rex Theatre, which was built about two years ago, and which is one of the finest buildings both from exterior and interior, was to have been torn down to make room for the building of the new postoffice which when completed will occupy almost half a block.

For a few months the house remained closed, but an enterprising citizen, M. Mannist, was granted leave by the government to re-open the building for the showing of moving pictures. Mr. Mannist stated in his request to the government that the theatre would be operated for the purpose of donating to the patriotic fund which is being raised here.

Some of the biggest features of the season are secured by Mr. Mannist and large crowds are attending the new house. The major part of the proceeds weekly are given to the Daughters of the Empire society in Calgary and the money is being expended for patriotic purposes.

The Rex was practically the first of the larger and more modern film houses to be built in this city. From the outside it presents a most beautiful appearance, being decorated from top to bottom with electric lights.

Delft Theatre Opens in Marquette

THE new Delft Theatre on Washington street, Marquette, Mich., opened at seven o'clock, Wednesday evening, November 4. It is owned by the Delft Theatres, Inc., of which H. S. Gallup is general manager and Morgan W. Jopling, president.

The theatre is one of the most modern in the upper peninsula and is entirely fireproof in construction. Shows will be given twice in the afternoon and twice in the evening, making a total of four shows daily. The theatre seats 300 on the main floor and 80 in the balcony. The decorations, both inside and out, are typical of Holland and harmonize well. The border in the exterior decoration is of blue tile in two colors; above the ticket office are four oval windows with Holland scenes.

The lighting system is distinctly individual; it is known as the "skylight" system and by its means a soft light is diffused throughout the theatre. In the center of the ceiling is a large window of colored glass, above which the electric lamps are placed.

Beneath the balcony are several indirect lamps. The house has installed two Power 6A machines. Miss Ada Mapes is in charge of the theatre. The Delft Theatres, Inc., will shortly open theatres in Munising and Escanaba.

Directory of New Theatres

New Feature Theatre For Dallas

A CONTRACT has been let and work started on November 1 on the construction or rather complete overhauling of a theatre in Dallas, which will be known as the "Feature Theatre." The sum of \$30,000 is to be spent in overhauling the theatre formerly known as the Crystal Theatre, a vaudeville house on Main street. The building is located in the heart of the theatre district of Dallas.

Ben B. Lewis, a local business man, is at the head of the company which has been formed to take over the playhouse. It is the plan of the promoters to show only feature pictures, as the name of the house indicates. Work will be pushed as fast as possible, and it is said that when the work is completed this will be one of the most beautiful picture houses in Dallas of the southwest.

Lakewood, Detroit, Ready Next Spring

ARCHITECT E. C. THULIN has about completed his plans for the new Lakewood motion picture theatre to be erected at Jefferson and Oneida avenues, Detroit. The building will be erected by a company to be known as the Lakewood Theatre Company, whose capital stock will be \$50,000.

The building will have a frontage of 66 feet on Jefferson avenue and will run back 140 feet; the seating capacity will be 1,000. The exterior will be of pressed brick and stucco; the front part will be occupied by stores and offices. The principal stockholders in this new enterprise are John Cutler, Bertha E. Cutler, C. J. Roberts and R. S. Larrabee.

Work will start inside of thirty days and the theatre completed by spring.

\$200,000 Theatre Opens in Milwaukee

THE first downtown photoplay house to open in over a year's time is the new Strand theatre, Fifth street and Grand avenue, which has just opened in Milwaukee. The house is one of the largest in the Northwest, seating 2,000, all on one floor.

It cost \$200,000 to erect and combines all of the most modern innovations with comfort and beauty. The admission price is to be ten cents, with the box seats at twenty cents. A magnificent three manual organ has been installed, which, combined with a splendid orchestra, should provide excellent music. Ethel Barrymore in "The Nightingale" opened the house.

The theatre is owned and operated by the Photoplay Company, and is under the management of Philip Gross, Jr.

Markee, Palo Alto, Has Gala Opening

THE new Markee Theatre of H. C. Schmidt has been opened at Palo Alto, Cal., the opening attraction being "Vendetta." This house is one of the finest on the San Francisco peninsula and caters especially to college folks, this city being the home of Stanford University. Mr. Schmidt is an officer in the Exhibitors League of California, and a large delegation of exhibitors and exchange men were present at the opening of his new house which took place on the evening of October 26.

Theatres Here and There

WORMALD and Thompson, who now operate a photoplay house at Conneautville, Pa., are erecting another house in the town. According to the agreement reached with the contractor the house will be completed by December 1. It will be thoroughly up-to-date and fireproof throughout, and will be erected according to the building code commission's requirements.

It will have a seating capacity of 250, and will cost when completed \$15,000.

Angelo Lazzari has completed the erection of his new house at Monongahela City, Pa. It has a seating capacity of 170, and is well located, and should do a large business. Warner's Features are to be used.

C. W. Shepp, a hotel proprietor of Irwin, Pa., will shortly open a motion picture theatre at Claridge, Pa., a mining town near Harmony, Pa. The new theatre will be called the Palace, and will have a seating capacity of 200.

Work is being rushed on the Garden Theatre, Johnstown, Pa., the work going on day and night so as to have the theatre ready to open by Thanksgiving Day. The theatre will have a seating capacity of 1,000. George Knox, the well known amusement man, will be manager of the theatre.

Carle Carlton's theatre at Butler, Pa., is rapidly nearing completion. The theatre will have a seating capacity of 325 seats, and will use Paramount pictures. It will be fireproof throughout, and will be one of the finest theatres in that section.

A. J. Arkush, who recently assumed charge of the Bell Theatre at Redwood City, Cal., is preparing to make a number of improvements, and will increase the seating capacity by 150.

The Elite Theatre, located in the northern part of Berkeley, Cal., and originally a part of the Turner & Dahnken Circuit, has changed hands, the new owner being C. N. Williams, formerly of Alameda, Cal.

Kahn & Greenfield have had plans drawn for the erection of a moving picture theatre on Fillmore street, at Eddy, San Francisco, and contracts for the construction of the house will be let at once. The theatre will have a seating capacity of one thousand, and will be ready for occupancy by the time the Panama-Pacific International Exposition is in full swing.

John's Theatre has been opened at East Oakland, Cal., by A. John, who also conducts a candy store in the vicinity.

R. E. Gumm, of Lagrange, Ky., has purchased the leases of the Palace and Majestic theatres at Corbin, Ky., and has assumed the management of these houses. Mr. Gumm has had several years' experience in the motion picture business.

Manager Stivers, of the Hipp Theatre, Jackson, Ky., is making a number of improvements in his house. A new hardwood floor, sanitary opera chairs of the latest design, a picture screen and a modern heating plant have been installed.

The Casino Theatre at 304 Federal street, North Side, Pittsburgh, has closed for repairs. Stein and Netzger are the proprietors. The theatre is being re-wired, the space in the operator's booth is being enlarged and the outside and inside are being repainted and decorated.

The Palace Theatre, 4829 Second avenue, Pittsburgh, is undergoing extensive repairs. The place was recently purchased by Max Steinberg. The theatre is to be re-wired, a double booth is replacing the single booth heretofore used and a new Powers 6-A machine is being installed. It is also being repainted throughout and will present a first class appearance when completed.

The Swisher Theatre at Morgantown, W. Va., including the real estate, was recently sold by Prof. Morris to George F. Briggs, of Norfolk. This is a large house of 1,200 capacity and has been used as a theatre. It is said a deal is under way for a lease by a Pittsburgh motion picture syndicate and indications point to it being turned into a motion picture theatre.

The Lyric Theatre at Butler, Pa., a new motion picture house of that town, was opened this week by Carle Carleton, its proprietor. The theatre has a capacity of 1,000 and is said to be the finest theatre in that part of the state. The Famous Players Film service is being used and a string orchestra furnishes the music.

Music and the Picture

The Wrong and the Right Attitude of the Motion Picture Musician

BY H. S. FULD

FROM time to time we have urged, in these pages, that the playing for pictures should not, in most cases, be attempted without the musician having his "stock in trade" by heart. Whether it is a "Photoplayer," a "Wurlitzer," or just a plain piano, try to avoid having a light burning in the orchestra pit. Try playing for the picture in the dark, with the only light that reflected from the screen when the picture is on.

True, there is nothing that sounds better than a good popular classical selection, when played right; but limit the playing of these to "scenic," "educational," or long scenes where the action on the screen would be helped, in your opinion, by such renditions. On these occasions, if you need the sheet music to play the selec-

tion, a light would be needed, and probably not noticed, but if the light is burning only to show the audience the identity of the player, why not use a spotlight and be done with it? Probably not more than a few are paying any attention to the music if the picture is being properly played to, which is as it should be.

"Grand-Stand Plays" Are Out of Place
If the music is right for the picture it will be inconspicuous, and be the right accompaniment for drama or comedy as the case

may be; but any "grand stand playing,"—for there is no better way of terming the playing of operatic or other selections at the wrong time—distracts the audience's attention from the picture. True, again, the artist might have exceptional ability and be not averse to exhibiting his talent, probably with no thought of applause, audible or otherwise; but imagine the clapping of hands at the close of a musical selection and the picture on the screen in the middle of a tense scene!

A New Song on Mary Pickford

The average audience in the motion picture theatre is not a music-loving one in its entirety; but, while most of those who take pleasure in viewing the pictures would, and probably do, appreciate good music, nevertheless the place for rendering these solos is either between pictures or as overtures before or between shows.

The chorus runs as follows:

She's the darling of the movies,
For she's "Such a little Queen,"
And she stepped right down into my heart
From a moving picture screen.
Fairy Mary, dainty as a Dresden doll,
Such a "Good little Devil" could make Satan on the level.
Mary Pickford, you're the darling of them all.

Scranton Will Have \$75,000 Theatre

MARKSVILLE, Pa., is to have a new motion picture theatre. A site has already been secured on the main street of the town, and the work of erection will start within a few days. The new house will have a seating capacity of about 500.

Meyer Davidow, a well known real estate broker of Scranton, Pa., has decided to erect a handsome motion picture theatre in the central city. He announces he will erect a modern fireproof building at the corner of Spruce and Wyoming streets. Plans have been submitted, and the contract will be awarded this week. According to the architect's estimates the new film theatre will cost more than \$75,000, exclusive of furnishings, which it is expected will demand the expenditure of \$40,000, making the building one of the handsomest theatres in the state of Pennsylvania.

The theatre when completed will have a seating capacity of 1,500, but will only have one balcony. There will be two ladies' retiring rooms and two men's smoking apartments on each floor, while a wide promenade will encircle the rear of the main floor. The equipment will include everything that is up-to-the-minute.

Washington, Detroit, Has New Organ

MANAGER HOWARD O. PIERCE feels very proud of the new pipe organ which has just been installed in the Washington Theatre, Detroit. The first recital was given Sunday afternoon, November 1. The organ is said to be the largest in the Middle West, the pipes ranging as high as twenty feet.

LATEST MUSIC FOR NOVEMBER

SONGS	INSTRUMENTAL
Let Them Alone, They're Married.	Do That Funny Fox-Trot.
Let the Whole World Know I Love You.	Gem Dance Folio, 1915.
Mississippi Cabaret.	Davis Fox-Trot.
Valley of the Moon.	Blue-Bird Hesitation.
You're More Than the World to Me.	Piping Rock, Fox-Trot.
When All the World's at Peace.	Dynamite Rag.
Just for Tonight.	Entertainers' Rag.
In the Hills of Old Kentucky.	Love's Melody Hesitation.
Love's Melody.	New Danse Folio.
Over the Alpine Mountains.	

SHAPIRO

REMICK

MORRIS

HAVILAND

WILL ROSSITER

FORSTER

STERN

FEIST

THE NEW BIG PICTURE DANCE BOOK

THE GEM DANCE FOLIO 1915

Containing 35 Complete Instrumental Pieces for the Pictures—A Great Big Book
SENT POSTPAID FOR 35 CENTS IN STAMPS OR MONEY ORDER

SHAPIRO, BERNSTEIN & CO.

224 W. 47th ST., NEW YORK

**THIS
CANNOT
POSSIBLY
MEAN
ANYTHING
TO YOU**

**If you are not
a Live Wire
Exhibitor**

**BECAUSE
ACCESSORY
NEWS
IS BUILT
FOR
LIVE WIRES
ONLY**

**Read It
and
See Why**

*A Hurdy-Gurdy Is Cheap—
But Who in the World Wants
a Hurdy-Gurdy?*



*Join the
happy
family of Exhibitors using the*
fotoplayer

(TRADE MARK REGISTERED)

“All but human orchestra”

Some New Members

*Hurtig & Seaman Circuit, N. Y. C.
72d Street Playhouse, N. Y. C.
Drury Lane, N. Y. C.
Regent Theatre, N. Y. C.
Halsted, East Orange, N. J.
New Grand, Paterson, N. J.
Royal, Perth Amboy, N. J.
Leavitt & Schagrin, Youngstown, O.
Reel, Cleveland, O.
Family, Cleveland, O.
Ivanhoe, Sandusky, O.
Columbia Opera House, Alliance, O.
Majestic, Roseburg, Ore.
Alta Theatre, Pendleton, Ore.
Princess, Murfreesboro, Tenn.
Columbia, East Liverpool, O.
New Theatre, San Francisco, Cal.
Lyceum, Baudette, Minn.
Turner & Dahnen Circuit,
San Francisco, Cal.*

*Alcazar Theatre, Chattanooga, Tenn.
Princess Theatre, Memphis, Tenn.
W. H. Wasserman, Nashville, Tenn.
Cort, Washington, Pa.
Crescent Amusement Co., Nashville,
Tenn.
Rex, Knoxville, Tenn.
Palace, Macon, Ga.
Star, LaGrange, Ga.
Colonial, Milledgeville, Ga.
Starland, St. Paul, Minn.
Casino, Des Moines, Iowa.
Crescent, Greenwood, S. C.
Cozy Tracy Theatre, Boise, Idaho.
J. A. Reeves, Warren, O.
Millers, Los Angeles, Cal.
Orpheum, Susanville, Cal.
Plaza, San Diego, Cal.
Broadway, Oakland, Cal.
Grand, Sioux City, Iowa.*

Write today for our Fotoplayer Special Proposition
(TRADE MARK REG.)



*Miss Norma Phillips
at the Fotoplayer*
(TRADE MARK REG.)

American Photo Player Co.
62 West 45th St., New York City

Moving Picture Scenarios

We are in the market for one and two reel comedies and comedy dramas.

Submit in typewritten form to

"SCENARIO EDITOR"

105 Lawrence Avenue, Dept C,
Dorchester, Mass.

Holland Film Manufacturing Co.



World
Film
Corporation

Presents a Shubert Feature
Clara Kimball Young
the most Popular Star in Pictures



Released

Nov. 23

IN LOLA

By Owen Davis

Arrange Bookings on this through
WORLD FILM CORP A ION
LEWIS J. SEIZNICK
Vice Pres. and Gen'l Mgr.
130 WEST 46TH ST., NEW YORK
27 Branches Throughout the U. S.
and Canada

PICTURE THEATRE EQUIPMENT COMPANY MOVES TO NEW QUARTERS ON TWENTY-THIRD STREET

H. T. Edwards has moved the Picture Theatre Equipment Company, so well known and long established at 21 East Fourteenth street, to a commodious ground floor store in the handsome Fifth Avenue building, New York City. Local exhibitors, managers and operators, as well as Mr. Edwards' large visiting trade will greatly appreciate the convenience and splendid facilities of the new location.

Mr. Edwards is the last of the old guard to leave the Fourteenth street section, which for several years was the centre of the picture industry in this city. He points with pride, however, to the fact that his business on Fourteenth street continued with constantly increasing success even after the trade in general had moved further uptown. This, of course, is due to the fact that the Picture Theatre Equipment Company is known from one end of the country to the other for its large and complete assortment of equipment and for Mr. Edwards' well-known reliability and thorough service to his customers.

In his new location at 19 East Twenty-third street, Mr. Edwards expects to make still more of a specialty of his mail order business. He is prepared to take care of any order, large or small, and to make shipments with the promptness for which his concern is so well and favorably known.

Present indications point to a rapidly increasing business for the firm.

Make Your Lobby Display Attractive

There is nothing more fascinating to the public than a bright brass frame to display your photos or posters.

We make Lobby and Theatre Fixtures and Brass Rails of every description.

Don't fail to visit our Showrooms.
Write for catalog.

THE NEWMAN MFG. CO.
717 Sycamore St., Cincinnati, Ohio
Branch Factories and Show Rooms:
101 Fourth Ave., New York, N. Y.
106-108 W. Lake St., Chicago, Ill.
Established 1882.



Are You Having Booking Trouble?

Are you getting the films you want—or are paying for?

Save trouble, time and money by booking your films through the

Managers Booking Bureau

Suite 1012, Hartford Building, Chicago
Phone—Central 2448

Motion Picture Booking for the States of Illinois, Indiana and Michigan.

Films Reviewed.
Exhibitors' Supply Service.

Information regarding any branch of the Motion Picture business

Write now for particulars.

FURNITURE & FURNISHINGS On RENTAL

We equip your settings complete in accordance with your scenario.

WILLIAM BIRNS

103-105 West 37th St.

Phone: Greeley 6255.

Your negative developed, printed and titled complete
5c per foot delivered **12** hours
within

Titles **6c** per foot

GUNBY BROS., Inc.

145 West 45th Street New York City

ROLL TICKETS Specially Printed and Absolutely Guaranteed

Cash with order. No C. O. D. at these prices.
50,000 for \$5.40 200,000 for \$15.30
30,000 for 4.50 100,000 for 9.00

Write for Samples and Prices on Other Quantities.

Rees Ticket Co., 400 So. 10th St., Omaha, Neb.

CLASSIFIED

FOR SALE

4 REEL FEATURE IVANHOE, by King Bagot, perfect condition, lots of paper, all sizes, taken for debt; must sell. W. K. MILES, Willow Grove, Penn.

PATHÉ PASSION PLAY

BEAUTIFULLY TINTED, 3 REELS, BRAND NEW, WITH
HERALDS AND LITHOGRAPHS, \$250.00

First come, first served. Wire your order now.

FEATURE FILM SALES COMPANY, Ltd.

172 WEST WASHINGTON STREET, CHICAGO

BARGAIN—Pearl screen, saves 60% electricity and gives best results, also talking moving picture machine, perfect, complete with films and records.

Feature Film Sales Co., Ltd.

172 W. Washington Street, Chicago, Ill.

Life Size Lobby PHOTOGRAPHS Boost Box Office Receipts

Original negatives of leading players of all West Coast studios in straight or character poses.

DISPLAYS NOW READY*

The Spoilers
St. Elmo
Little Sunbeam

The Avenging Conscience
Will O' The Wisp
The Hoosier Schoolmaster

The Blood Red Rose
Terrance O'Rourke Series

DISPLAYS OF COMING RELEASES
The Carpet From Bagdad
The Rosary

*Displays include either character or straight photographs. INTRODUCTORY OFFER CLOSES DECEMBER 1ST. WRITE NOW.

PHOTOPLAYERS' STUDIO

342 SO. BROADWAY

LOS ANGELES, CAL.

Only exclusive professional studio on Pacific Coast where 80 per cent. of American motion pictures are made.

ANIMATED SONGS

NOTHING MECHANICAL

NO PHONOGRAPH RECORDS

MOTION PICTURES THAT MOVE TO THE RHYTHM OF SONG

IMPERIAL MOTION PICTURE CO. OF NEW YORK, Inc., 1476 Broadway

Exhibitors—IT'S A— KNOCK-OUT

The Smashing Big New 24-Sheet Stand for the Great "MASTER KEY" Serial—You Could Hunt America from End to End and Not Find Its Equal



GENTLEMEN: In the production of this super-magnificent 24-sheet poster for The Master-Key serial, we have just knocked competition cold. Your competitors will grow green with envy—they will hate you in their hearts, but while they are hating—YOU—(get that) YOU will be getting the merry old coin. We have spent tall dough to work out this stand. It's so strong, so compelling, so all fired powerful as to make you gasp in wonder. It is done in 5 colors, simply lavish, a dream of Art. NOW GET THESE POSTERS. Put them up on extremely prominent boards. THEY WILL JAM YOUR HOUSE. Nothing you've ever seen begins to equal them. They will make the average poster sink into absolute insignificance. These 24-sheet stands are a genuine masterpiece and a veritable "Knock-out." Now do it right. Order these **DIRECT** from your Exchange. Order NOW, this minute. The public will imagine you're running a Broadway show house. The results will knock you silly. Hundreds of "Shrewd" exhibitors are using these 24-sheet posters. **ORDER THEM IMMEDIATELY.** Better wire your exchange as quick as you see this Ad. Or if you can't get them from your own exchange, write or wire

The Morgan Lithograph Company, Cleveland, Ohio

or Service Department

UNIVERSAL FILM MANUFACTURING COMPANY

1600 Broadway

Carl Laemmle, Pres.

New York City

UNITED FILM SERVICE

RELASING the weekly United Program of single-reel comedies and dramas—Features in two and three reels—Specials in four or more reels—all by the world's best producers. The exhibitor can obtain from the United Film Service a complete and diversified program in single and multiple reels to fit his every requirement.

**There are 42
UNITED EXCHANGES**
Write the one nearest you
WARNER'S FEATURES INC.
NEW YORK CITY

NOVEMBER 28, 1914

Motion Picture News

HAS THE QUALITY CIRCULATION OF THE TRADE

PARAMOUNT PICTURES

JESSE L. LASKY

PRESENTS
AMERICA'S PREMIER CHARACTER ACTOR

THEODORE ROBERTS

IN
A VIVID, TELLING ROMANCE OF THE SAW DUST RING
"THE CIRCUS MAN"

FROM THE FAMOUS NOVEL
THE ROSE IN THE RING
BY GEORGE BARR McCUTCHEON

RELEASED NOVEMBER 19

JESSE L. LASKY FEATURE PLAY CO.

LONG ACRE THEATRE W. 48TH STREET N. Y. C.

JESSE L. LASKY SAMUEL GOLDFISH CECIL B. DeMILLE
PRESIDENT TREAS. & GENL. MANAGER DIRECTOR GENERAL



ROBERT LEONARD AND ELLA HALL
IN



THE MASTER KEY

by **JOHN FLEMING WILSON**

*A Thrilling Story of
Mystery and Romance!*

FIFTEEN MONDAY WEEKS
UNIVERSAL
THIRTY REELS
PICTURES

SPECIAL
UNIVERSAL
EPISODE TWO

PARAMOUNT

PICTURES

DANIEL FROHMAN

Presents

The distinguished comedienne,

MAY IRWIN

In her greatest stage success



THE FAMILY CIRCLE
AT LAST COMPLETE.

“MRS. BLACK IS BACK”

By George V. Hobart,

America's foremost comedy-artiste in one of
America's funniest comedies,

In Four Parts of
Motion Pictures,

Released
November 26th.

Produced by the

FAMOUS PLAYERS FILM CO.

ADOLPH ZUKOR, President,

DANIEL FROHMAN, Managing Director EDWIN S. PORTER, Technical Director

Executive Offices,

213-229 W. 26TH STREET, NEW YORK.

36
FAMOUS
FEATURES
A YEAR

36
FAMOUS
FEATURES
A YEAR

BIG MONEY DAYS!



SPECIAL FEATURE DAYS ARE THE BIGGEST AND BEST ADVERTISING YOU CAN GIVE YOUR THEATRE AND THEY PUT CASH IN YOUR POCKET



Fleeing From the Volcano in "The Wrath of the Gods"

BEGIN WITH THIS LIST AND GO THROUGH WITH IT

THE WRATH OF THE GODS

Six smashing, thrilling reels of concentrated drama produced by

THOS. H. INCE

Japanese Story, Japanese Actors, Volcano in Eruption!

Filling theatres. It fattens your box office—book it now

Griffith Produced

THE BATTLE OF THE SEXES

in five reels. The vital material would have made eight but that isn't Griffith's way. Greatest story of the Double Moral Standard ever produced or written. It jams theatres. **BOOK IT!**

A Sensational Feat That Will Set Your Whole Neighborhood Talking Is the Climax of

THE GREAT LEAP

MAE MARSH and **ROBERT HARRON** are the stars; four reels is the length and intense drama wonderfully well presented is the big claim to your attention.

HOME SWEET HOME

THE GREAT GRIFFITH MASTERPIECE IN SIX REELS OF HEART APPEAL, TENSE INTEREST, VITAL ACTION AND GORGEOUS INVESTITURE. WHEN "HOME SWEET HOME" BOOKS IT RE-BOOKS BECAUSE OF POPULAR DEMAND. THIS IS THE PRIME SEASON FOR REALIZING ON THE PROFIT OPPORTUNITY.

All Mutual Exchanges

CONTINENTAL FEATURE

29 UNION SQUARE,

BIG MONEY NIGHTS!

THESE SPECIAL FEATURES WILL FATTEN YOUR BOX OFFICE AND GIVE YOUR HOUSE A REPUTATION FOR PRESENTING THE BEST



*FOR A WAR
FEATURE DAY
SHOW ONE
OF THESE BIG
SUCCESSSES*

MEXICAN WAR PICTURES

By Special Contract with General Villa

THE DISHONORED MEDAL

With French Troops in action

BATTLE OF GETTYSBURG

Greatest War Feature Ever Produced

BIG DAY SPECIALS

THE MOUNTAIN RAT 4 Reels

A tense vital drama of Western Life, telling the story of a human rat

GANGSTERS 4 Reels

Great run at Weber's Theatre, New York. "A great lesson for all."—New York American

RUY BLAS

with William Garwood and
Francelia Billington

THE FLOOR ABOVE

the great Oppenheim mystery
story

FROU FROU

with Maude Fealy, after Au-
gustine Daly's Production

SAPHO

with Florence Roberts

MOTHS

from Ouida's great novel, a
Thanouser Big Production

DOPE

with Laura Nelson Hall

CARDINAL RICH- ELIEU'S WARD

Florence La Badie and James
Cruze

ZU ZU

the BAND LEADER, a two-
reel Keystone, with
Mabel Normand

JOSEPH IN THE LAND OF EGYPT

James Cruze as Joseph, Mar-
guerite Snow as Potiphar's wife

LEGEND OF PRO- VENCE

James Cruze and Maude Fealy

FILM CORPORATION
NEW YORK CITY

*All Mutual
Exchanges*



THE BEST THERE IS

for the week of November 22nd



MUTUAL PROGRAM

MUTUAL PROGRAM

20-103 XROY EBN

PHOTOS—8 by 10 photos of the KAY BEE, KEYSTONE, BRONCHO, and DOMINO players can be secured by sending to the PUBLICITY DEPT., 15 cents for one, 50 cents for set of four, one dollar for set of eight, etc.

KEYSTONE MABEL IN FOUR NEW STYLES—15 cents for one, 50 cents for set of four, etc. PENNANTS—Beautiful colored pennants of our four brands, KAY BEE, KEYSTONE, BRONCHO and DOMINO, 25 cents for one, one dollar for set of four.

NEW YORK MOTION PICTURE CORPORATION

AD KESSEL, Jr., President

LONGACRE BUILDING,

42d ST. and BROADWAY



ABOVE ALL QUALITY

MUTUAL PROGRAM



MUTUAL PROGRAM THE MAJESTIC MOTION PICTURE CO.

Two part feature release

SUNDAY, NOV. 29

THE FAMOUS GISH SISTERS

LILLIAN and DOROTHY



LILLIAN GISH

Appearing for the first time
together in a Majestic
release



DOROTHY GISH

In the splendidly acted and produced heart-
appealing drama

THE SISTERS

Telling a story of absorbing interest

This is a feature release of first quality

MAJESTIC AND KOMIC GUIDE FOR EXHIBITORS

(In which we try to tell only the truth about all Majestic and Komic releases)

- THE LITTLE COUNTRY MOUSE** (1 Reel Majestic) Release date Tuesday, Nov. 17—A pleasing story and picture play featuring Blanche Sweet, in which a young girl is saved from the snares of high society.
- THE SAVING GRACE** (2 Reel Majestic) Release date Sunday, Nov. 22—A decidedly refreshing and entertaining comedy drama, with Dorothy Gish in the leading part. The new parson redeems the simple country girl from ignorance and by his vigorous action saves the father from crime.
- ETHEL HAS A "STEADY"** (1 Reel Komic) Release date Sunday, Nov. 22—No. 11 of the famous Bill, the Office Boy stories of Paul West, featuring Fay Tincher, as Ethel, the stenographer. A good number, in which Bill's love letter causes trouble for Ethel.
- ANOTHER CHANCE** (1 Reel Majestic) Release date Tuesday, Nov. 24—A melodrama of fair interest and quality, in which an ex-convict is saved from a return to crime by the interference of a crippled newsboy whom he had befriended.
- THE SISTERS** (2 Reel Majestic) Release date Sunday, Nov. 29—Featuring Lillian and Dorothy Gish. For our candid opinion see announcement above. The story tells of a mutual love and sacrifice of two young mothers under circumstances that will touch the heartstrings of every spectator.
- A CORNER IN HATS** (1 Reel Komic) Release date, Sunday, Nov. 29—A very good farce with a novel idea, showing how much trouble an industrious dog can create.

MAJESTIC MOTION PICTURE COMPANY

Studios: 4500 Sunset Blvd.
Los Angeles, Calif.

Business offices, 29 Union Sq. W.
New York City.



ABOVE ALL QUALITY

MUTUAL PROGRAM

See Americans First
FLYING "A" and AMERICAN "BEAUTY"
FEATURE FILMS



"THE BEGGAR CHILD"

In Two Reels

A Tense Human Interest Drama

Featuring ED COXEN and WINNIFRED GREENWOOD

Under direction of Henry Otto

Release Monday, November 30th, 1914

AMERICAN BEAUTY FILMS

Featuring MARGARITA FISCHER and HARRY POLLARD

A Refined Gem

"CUPID AND A DRESS COAT"

Release Tuesday, Dec. 1st, 1914

"THE STRENGTH O' TEN"

A "Flying A" drama of Virginia

Featuring WM. GARWOOD and VIVIAN RICH

Release Wednesday, Dec. 2nd, 1914



Distributed exclusively through the United States and Canada by the
Mutual Film Corporation

AMERICAN FILM MFG. CO.
CHICAGO

STATE RIGHTS

ON WHAT ARE CONSIDERED THE GREATEST MASTERPIECES EVER PRODUCED. AN OPPORTUNITY TO GET THE BEST RELEASES ON THE MARKET FOR A STATE RIGHTS PROPOSITION—ADVERTISING PROPS AND SPECIAL MATERIAL ALL READY TO WORK WITH. TERRITORIES OPEN INCLUDE BEST IN THE COUNTRY.

THE ESCAPE

THIS REMARKABLE SEVEN REEL D. W. GRIFFITHS PRODUCTION WILL GET THE MONEY FOR YOU FOR YEARS TO COME. IT IS A STRONG COMPELLING DRAMA TREATING ON A SUBJECT THAT WILL NEVER GROW OLD. THE MASTER HAND OF GRIFFITHS IS SEEN ALL THROUGH THE PRODUCTION AND THE COMPELLING DRAMATIC ACTION WILL FILL ANY AUDIENCE WITH AWE.

THE AVENGING CONSCIENCE

IS AN ADAPTATION OF EDGAR ALLEN POE'S GREAT MASTERPIECE "THE TELLTALE HEART." D. W. GRIFFITHS HAS POSITIVELY REPRODUCED ALL THE SUBTLE, WEIRD EFFECTS AND WONDERFUL DRAMATIC CLIMAXES FOR WHICH POE IS NOTED. THIS SIX REEL PRODUCTION CAN BE RENTED NOT ONLY FOR TODAY AND TOMORROW, BUT WILL LIVE FOREVER. EVERY POSSIBLE ADVERTISING PROP IS READY ON THIS MASTER PHOTO PLAY. A SPECIAL PROPOSITION WILL BE GIVEN TO STATE RIGHTS BUYERS TAKING BOTH SUBJECTS.

SEND AT ONCE FOR FULL PARTICULARS, PRICES, AND TERRITORY OPEN

WESTERN IMPORT CO.
71 WEST 23RD STREET, N.Y.

RUNAWAY JUNE

IS THE NAME OF
THE GREATEST, GRANDEST MOST SENSATIONAL AND ELABORATE
SERIAL EVER PRODUCED

GEORGE RANDOLPH CHESTER

IS KNOWN AS
THE WORLD'S GREATEST WRITER - HIS WORKS HAVE BEEN READ BY
MILLIONS - 4,000,000 COPIES OF HIS J. RUFUS WALLINGFORD
BOOKS HAVE BEEN SOLD. HE WAS PAID A FORTUNE TO WRITE

RUNAWAY JUNE

2500 NEWSPAPERS

ALL OVER THE COUNTRY
WILL CARRY THE STORY OF RUNAWAY JUNE - IT WILL
COMMENCE EARLY IN JANUARY

THE RELIANCE MOTION PICTURE CO.

WILL PRODUCE
RUNAWAY JUNE AND HAVE ALREADY SPENT A FORTUNE ON IT.
PICTORIALLY AND FROM THE DRAMATIC STANDPOINT IT WILL BE
THE GREATEST SERIAL SERIES EVER RELEASED - TWO REELS
A WEEK FOR FIFTEEN WEEKS.

YOU CAN GET FULL INFORMATION REGARDING RUNAWAY JUNE
BY WRITING TO THE RELIANCE MOTION PICTURE CO.

29 UNION SQUARE, NEW YORK CITY, OR

ANY MUTUAL EXCHANGE

22 Episodes Now Appearing THE MILLION DOLLAR MYSTERY

The spectacular acting of Florence La Badie and Sidney Bracy is holding audiences spellbound in these 22 Episodes of astounding thrills and startling surprises. The Million Dollar Mystery is an independent release and may be secured regardless of the regular program being used. Apply to

Syndicate Film Corporation

71 West 23rd St., New York City
Room 411, 5 So. Wabash Ave., Chicago

(Or Syndicate Film Corporation's Representative at any Mutual Exchange in United States and Canada.)

The Thanhouser Three-a-Week

NOTE—*Florence La Badie* and *Sidney Bracy*—America's two foremost photoplay stars who made such pronounced successes in *The Million Dollar Mystery*—appear in regular Thanhouser releases. These releases are distributed exclusively in the United States and Canada by the Mutual Film Corporation.

Tuesday, Nov. 24th—"Mrs. Van Ruyter's Stratagem," (2 reels) a drama depicting the life of a wealthy widow who doubts the character of the relatives who are to inherit her fortune. Her lawyer suggests she change places with her housekeeper and invite the relatives, who live in different states, to visit her. In the position of housekeeper, she discovers a plot between the butler and her niece to discredit the new maid. She succeeds in having this matter righted. She finally makes a new will much to the sorrow of all her relatives. A very interesting play cleverly acted by—*Carey L. Hastings, Ethel Cooke, Harry Benham, Helen Badgley and Muriel Ostriche.*

Sunday, Nov. 29th—"A Denver Romance." This drama centers around a young western girl who has just returned from an eastern college. At the railroad station she meets a young New York bachelor who is traveling West to see the country. Her father is an old Westerner who believes that all Easterners are effeminate and lacking in manhood, but is finally converted by the young New York bachelor after a wonderful display of guns. The cast includes *Mignon Anderson and Morris Foster.*

Thanhouser Film Corporation

NEW ROCHELLE, NEW YORK

Head European Office, Thanhouser Films, Ltd., London, W. C., England

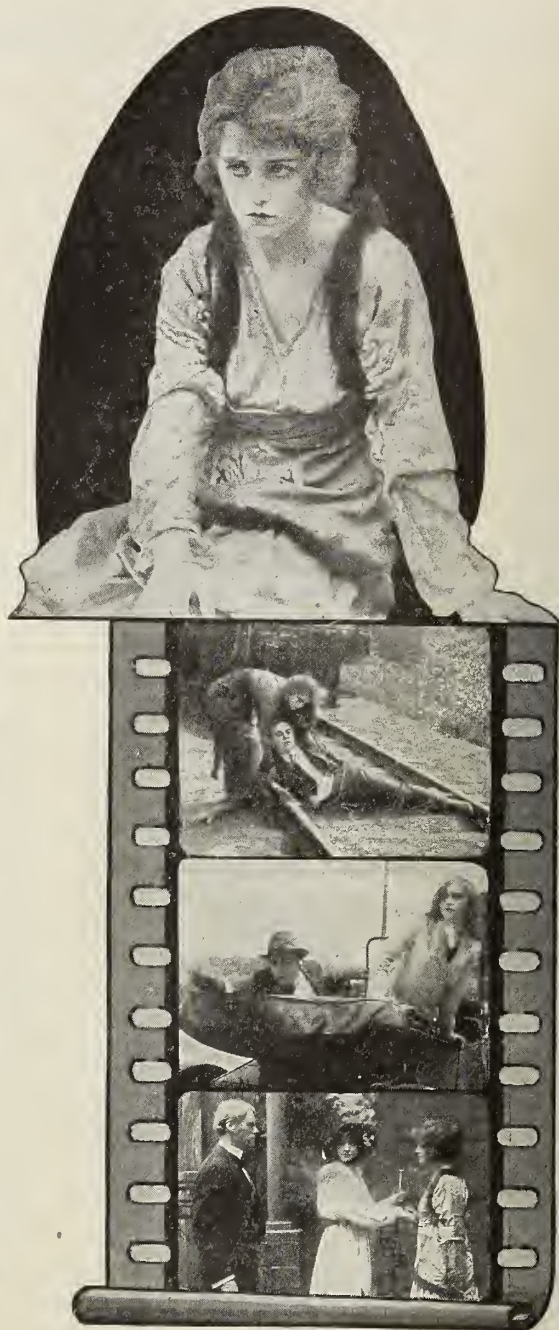

"CABIRIA" STARS IN LATEST ITALA FEATURES

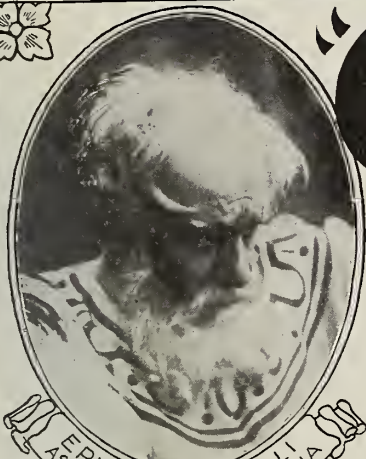

ERNESTI CAMELLI
AS ARCHIMEDES IN "CABIRIA"



LYDIA QUARANTA
AS "CABIRIA"

Jules Porel - Serpent

IN 3 PARTS
AND 110 SCENES



The Treasure of the Louzats



IN 4 PARTS
AND 200 SCENES

STATE RIGHTS OPPORTUNITIES
OF VITAL LIVING STRENGTH

Address

Harry R. Raver

Director General

Itala Film Company of America

Candler Building N.Y.C.

PARAMOUNT PICTURES

BOSWORTH

INC.

LOS ANGELES

PRESENTS

ADELE FARRINGTON



IN

THE COUNTRY MOUSE

A RIPPLING COMEDY, REPLETE WITH STIRRING SOCIAL AND POLITICAL SCENES. A TYPICAL DRAMA OF LOVE, POLITICS AND THE HOME - THE MAKING OF A STATESMAN - THE AWAKENING OF A WOMAN.

RELEASED NOVEMBER 23RD THROUGH THE
PARAMOUNT PROGRAM

BOSWORTH

INC.

FAMOUS PLAYERS FILM CO. THE PRODUCTIONS OF BOGSWORTH INC.
 In Association with Associated with Associated with
 Daniel Frohman David Belasco Lois Weber
 Chas. Frohman-Henry W. Savage The Liebler Company Phillips Smalley
 CONSTITUTE

Paramount Pictures

• Our Contract •

Gives the exhibitor of Paramount Pictures many valuable advantages.

1st—The Paramount Exhibitor has the Best Motion Pictures yet produced.

2nd—He is assured a continuous supply of pictures of the same high standard.

3rd—His efforts to build up a clientele are supported by the Paramount National Advertising Campaign, the results of which are bringing the best people to Paramount Theatres in every section of the United States.

Paramount Pictures are helping the Exhibitor to raise his prices of admission and so conduct his business more profitably.

Are you one of these successful Exhibitors? If not, write our nearest exchange now for information about Paramount Service.



Paramount Pictures Corporation
 ONE HUNDRED and TEN WEST FORTIETH STREET
 NEW YORK, N. Y.





Tremendous Opportunity For Wide-Awake State Right Buyers

THE Balboa Amusement Producing Company, of Long Beach, California, manufacturers of St. Elmo which has smashed box office records all over the country and will continue in popular esteem for years to come, is now ready to dispose of the state rights of

Beulah in 6 Reels

Beulah was written by Augusta J. Evans as a sequel to St. Elmo and has been read by generation after generation of book-loving Americans. It is a wonderful story wonderfully told—a romance of the Southland—a genuine, heart-gripping work of fiction with a bigger plot, more action, deeper mystery, sweeter sentiment and stronger passions than St. Elmo. It adapts itself to the screen with surprising ease and as a motion picture offering that will stand supreme among the masterpieces of cinematography.

What St. Elmo Has Done and Will Do

Since its release St. Elmo has been in constant demand by exhibitors in every section of the United States. It will make more net profit than any other motion picture attraction now before the public.

Beulah in 6 Reels

will be an elaborate production with more than 200 gorgeous scenes. The cast is one of the strongest ever assembled. St. Elmo is great, but Beulah will be greater—greater because of the more extensive experience and improved equipment of the Balboa Company which now has a hundred winning features to its credit.

You Take No Chances With Balboas

Balboa features, always highly dramatic and rife with human interest, are perfect in photography and all those essentials that combine to make crowd-drawing, money-making photo-plays. If you are in the market for the state rights of Beulah, get in touch with us at once. Write or wire without delay. This is the first Beulah announcement, and in view of the unprecedented success of St. Elmo, Will O' the Wisp, The Criminal Code, The Square Triangle, The Rose of the Alley and other Balboa films, there will be a big demand for our latest and greatest motion picture achievement.

THE BALBOA AMUSEMENT PRODUCING CO.

H. M. Horkheimer,
President and General Manager

E. D. Horkheimer,
Secretary and Treasurer

Studios and Executive Offices: LONG BEACH, CALIF.

Exhibitors! Get a Box Office Winner!

NOW READY FOR RELEASE ON
National Tuberculosis Day, Sunday, November 29th



"Dr. De La Roche explains Life theories"

A MASTERFUL 6-PART FILM PLAY WITH SCIENTIFIC PUNCHES AND A SYMPATHETIC LOVE MOTIVE.

Written and
Filmed by

WILLIAM STOERMER

Producer of America's
Oberammergau Passion Play

Theme and Thesis in collaboration with eminent medical specialists and California Health Authorities. With a notable cast of Players, Perfect Photography, Elaborate Settings, Costumes and Photographic Effects.

This is a heart interest story vividly portraying

LIFE—with its
PERPLEXING INCIDENTS!—its
UNEXPECTED PROBLEMS!—its
SENSATIONAL EFFECTS!!

Depicting the Cause, Proper Prevention methods
and the Cure of the Great White Plague—

TUBERCULOSIS

A story compelling your attention. Scientifically correct. A Filmization holding your interest throughout as well as the children.

PRESS—PULPIT AND PUBLIC—MEMBERS OF THE MEDICAL PROFESSION AND SOCIAL WORKERS WILL RECOMMEND AND INDORSE THE PRESENTATION OF THIS REMARKABLE PICTURE TO YOUR CLIENTELE.

NOW READY: A Laugh with that Funny Man, Johnny Brennon, "Skinny's Finish," 1 reel.

Further information given upon request. Write or Wire.

Exhibitors' Producing and Exchange Syndicate

MANUFACTURERS AND PRODUCERS

Los Angeles, Cal., U. S. A.

WILLIAM STOERMER
Pres. & Managing Director

WESTERN LABORATORIES
651 Fairview Ave., Brooklyn Heights

SPECIAL FEATURES

General Film Company

TITLE	MAKE	No. of Reels	TITLE	MAKE	No. of Reels
THIRD DEGREE	Lubin	5	MAN'S ENEMY	K. & E. Biograph	3
THOR, LORD OF JUNGLE.....	Selig	3	IN TUNE WITH THE WILD.....	Selig	3
THE BATTLE OF SHILOH.....	Lubin	4	THE WOLF	Lubin	6
THE LION AND THE MOUSE.....	Lubin	6	SHADOWS OF THE PAST.....	Vitagraph	3
THROUGH FIRE TO FORTUNE.....	Lubin	5	MR. BINGLES' MELODRAMA.....	Vitagraph	3
JUDITH OF BETHULIA.....	Biograph	4	MEN AND WOMEN.....	K. & E. Biograph	3
GERMINAL	Pathe	5	THE SECRET OF THE RING.....	Kleine	3
LOST IN MID OCEAN.....	Vitagraph	3	MY FRIEND FROM INDIA.....	Edison	3
A ROMANY SPY.....	Pathe	3	LIBERTY BELLES	K. & E. Biograph	3
A CELEBRATED CASE.....	Kalem	4	THE ERRING	Lubin	3
THE FULFILLMENT	Essanay	3	AMBUSHED	Essanay	3
NIGHT RIDERS OF PETERSHAM.....	Vitagraph	3	SONG OF THE SOUL.....	Kleine	3
HARDING'S HERITAGE	Pathe	3	KIT, THE ARKANSAS TRAVELER.....	Kalem	3
DAUGHTERS OF MEN.....	Lubin	5	CHIP OF THE FLYING "U".....	Selig	3
THE OTHER HALF OF THE NOTE.....	Kalem	3	FAIR REBEL	K. & E. Biograph	3
HER LADYSHIP	Selig	3	HOUSE NEXT DOOR.....	Lubin	5
GOODNESS GRACIOUS	Vitagraph	3	MY OFFICIAL WIFE.....	Vitagraph	5
OFFICER JIM	Lubin	3	UNCLE BILL	Vitagraph	3
DEATH SIGN AT HIGH NOON.....	Kalem	3	THE FORTUNE HUNTER.....	Lubin	6
GAME OF LIFE.....	Selig	3	THE VENDETTA.....	Kleine	5
THE MILITANT SUFFRAGETTE.....	Pathe	5	BAREFOOT BOY	Kalem	3
FRANCIS MARION, "THE SWAMP FOX".....	Kalem	3	THE WIFE	K. & E. Biograph	3
A MILLION BID.....	Vitagraph	5	KING OF CHANCE.....	Kalem	3
THE FATAL WEDDING.....	K. & E. Biograph	3	THE WAGES OF SIN.....	K. & E. Biograph	3
THE GAMBLERS	Lubin	5	THE PLUM TREE.....	Essanay	3
ANNE BOLEYN	Kleine	3	THE FIFTH MAN.....	Selig	3
STRUGGLE FOR LIFE.....	Pathe	5	THE GOLDEN BEETLE.....	Kleine	4
MONGREL AND MASTER.....	Essanay	3	THE WEIGHT OF A CROWN.....	Lubin	3
THE ROYAL BOX.....	Selig	4	MARAH, THE PYTHONESS.....	Lubin	3
THE CURSE OF OREED.....	Melies	5	CHARITY BALL	K. & E. Biograph	3
FACING THE FOOTLIGHTS.....	Pathe	3	HEARTS AND MASKS.....	Selig	3
BLOOD WILL TELL.....	Essanay	3	A FLORIDA ENCHANTMENT.....	Vitagraph	5
CONQUEST OF QUEBEC.....	Kalem	5	ROAD TO YESTERDAY.....	K. & E. Biograph	3
THE LILY OF THE VALLEY.....	Selig	3	THE PAINTED WORLD.....	Vitagraph	3
CLASSMATES	K. & E. Biograph	4	JUDGE NOT	Kleine	4
MAN OF THE HOUR.....	Selig	3	GARRISON'S FINISH	Selig	3
MR. BARNES OF NEW YORK.....	Vitagraph	6	POWER OF THE PRESS.....	K. & E. Biograph	4
LOVE, LUCK AND GASOLINE.....	Vitagraph	3	IN THE GLARE OF LIGHTS.....	Essanay	3
THE BILLIONAIRE	K. & E. Biograph	3	THE RED CROSS NURSE.....	Melies	3
SPORT AND TRAVEL IN CENTRAL AFRICA	Pathe	5	THE THREADS OF DESTINY.....	Lubin	5
THE GOOD FOR NOTHING.....	Essanay	4	WHEN THE LIONS ESCAPE.....	Melies	3
THE BOER WAR.....	Kalem	5	THE GENIUS	K. & E. Biograph	3
THE THUMB PRINT.....	Melies	4	STONEWALL JACKSON'S WAY.....	Lubin	3
STRONGHEART	K. & E. Biograph	3	THE INVISIBLE POWER	Kalem	4
LORD CHUMLEY	K. & E. Biograph	4	THE WOMAN IN BLACK.....	K. & E. Biograph	4
SEVEN DAYS	K. & E. Biograph	4	UNDER THE GASLIGHT.....	K. & E. Biograph	4
TREASURE OF ABDAR RAHMAN.....	Pathe	4	"413"	Vitagraph	3
'NEATH THE LION'S PAW.....	Melies	3	THE WIN(K)SOME WIDOW.....	Vitagraph	4
ONE WONDERFUL NIGHT.....	Essanay	4	THE STORY OF THE BLOOD RED ROSE.....	Selig	3
WOMAN AGAINST WOMAN.....	K. & E. Biograph	3	THE TELL TALE HAND.....	Essanay	3
IN DEFIANCE OF LAW.....	Selig	3	A POOR RELATION.....	K. & E. Biograph	3
A KINGDOM AT STAKE.....	Kleine	3	THE LOCKED DOOR	Vitagraph	3
CAPTAIN ALVAREZ	Vitagraph	6	THE TANGLE	Vitagraph	4
OTHELLO	Kleine	5	THE SPY'S FATE	Lubin	3
SHANNON OF SIXTH.....	Kalem	5	IN THE DAYS OF THE THUNDERING HERD	Selig	5



EXHIBITORS



When we tell you that our *All American Made* program will be of compelling interest to the most critical moving picture fan, we feel absolutely safe in making such an assertion. We want you, too, Mr. EXHIBITOR, to allow yourself to become interested in the

KRITERION SERVICE

Which means

EVERY DAY A COMEDY

EVERY DAY A DRAMA

EVERY DAY A SPECIAL

and

EVERY SUNDAY A KRITERION ★ SUBJECT

Our early ideas and ambitions to give the Exhibitor something he wanted and really needed will be more than realized when our product is screened.

If you will accept good advice, communicate with us immediately and make arrangements for a screen demonstration, also to get acquainted with our distributing agent in your territory.

FOR

KRITERION SERVICE

MICA FILM CORPORATION

222 West 42nd Street

New York City





**Cast of 1000
3000 Scenes**

ZUDORA

Thanhouser's Greatest Photoplay

An extraordinary cast of 1000—headed by Marguerite Snow, the star of *The Million Dollar Mystery*, James Cruze and Harry Benham—present *Zudora* in 3000 spectacular scenes—20 episodes

Each of these astounding episodes portrays science, love, mysticism, and adventure; bound to thrill—bound to fascinate and capture your audiences. This remarkable story by Harold MacGrath and Daniel Carson Goodman, America's foremost authors, is being released in 20 episodes, two reels each week. First release date was Nov. 23rd.

EXHIBITORS: Remember the wonderful success of *The Million Dollar Mystery* and arrange now to secure *Zudora*. *This is your opportunity.* Apply to the Thanhouser Syndicate Corporation's representative at any Mutual Exchange in the United States and Canada. This is an independent release and may be obtained regardless of regular program being used.



Trade Mark Registered

Thanhouser Syndicate Corporation

71 West 23rd Street, New York

*Produced by Thanhouser Film Corporation, New Rochelle, N. Y.
Producers of The Million Dollar Mystery.*

206

"When You See It
In 'The News'
It's NEWS"

Motion Picture News

HAS THE QUALITY CIRCULATION OF THE TRADE

"The Exhibitors"
Medium of
Communication"

TEL. 7650 BRYANT

TWO-TWENTY WEST FORTY-SECOND STREET

NEW YORK CITY

Volume X

NOVEMBER 28, 1914

Number 21

Getting Down to Brass Tacks

A VERY prominent film executive told me of an interesting incident last week.

He had a letter from a well-known Southern banker and business man asking for a New York appointment and assumed the call would relate—possibly—to railroad or other construction matters.

To his surprise, his caller plunged brusquely into a keen discussion of film exchange and theatre conditions. It appeared he was largely interested in a new chain of picture theatres.

* * *

"THIS is a bit out of your line, isn't it?" asked the film executive, as his caller was leaving. "I am wondering what induced you to become an exhibitor."

Mr. Southerner's reply is significant.

"My associates and I," said he, "after a very careful investigation came to the decision that *good business methods*—largely the same methods that are standard in other lines—would bring very successful results in the exhibiting business.

And so we have found it.

"There is plenty of competition so far as *numbers* of theatres is concerned—*too much*.

"But there's little competition as concerns *keen business management and clear policies*."

* * *

A NEW era is on in the exhibiting business. It has been growing steadily and sturdily. The handwriting is on the wall for every exhibitor to read.

Many more men like the Southern banker are in the business and are going into it—everywhere. They are bringing with them positive methods and thought. They are inducing a new kind of competition—not of numbers of theatres, but of well built, thoroughly equipped theatres run by the rules of the modern, systematic retail store.

And the same new era is on with the producer of pictures.

* * *

THE first and best producing successes were made and continued to be made, simply through the introduction into the business of mathematical reasoning and merchandising sense.

It has been remarked as strange that this has not become more general, but it is—*now*.

Business executives, trained to other and older—if not greater—industries, are entering the ranks here and there and are making themselves felt in no uncertain way. They are patiently introducing system and sense and impatiently crowding out loose action and talk—jealousies, temperament, gossip, exaggeration, *gambling*.

They are getting the business down to brass tacks.

OFTEN it is argued that this is an amusement business and so cannot be ruled economically and methodically. Which is *wrong*.

It is as baldly untrue as to say, concretely, that a picture costing ten thousand dollars and working one day a month can compete successfully with as good a picture costing two thousand and working thirty days' a month.

Again, this business has a small retail price. You can gamble with some percentage with stage productions where the retail—or admission—price is two dollars. But you can't gamble wildly with nickels and dimes in a field where over-production already rules.

* * *

QUALITY production—that is the *first big essential*—and here you have the artistic element that distinguishes the business from most other manufacturing lines. But here the artistic ends.

Elimination of studio and factory waste, elimination of distribution waste—these are just as essential to pictures now as to crackers.

The far-sighted producers—naturally they are the leaders—*know this*.

They are agreed on one point: that this industry will be, *must be*, regulated along the same old and inviolable laws of economy that rule *all* industries. They have forgotten the past.

And they are agreed on another point: *that co-operation and understanding with the exhibitor is a necessity*. Again, the old days are gone.

* * *

THIS isn't a dream—I can hear some exhibitors laughing—it is plain horse sense.

The exhibitor today who thinks the manufacturer his enemy is as far off the track as the producer who jumps into this field without a clear knowledge of exhibitor wants and needs—or is unequipped to supply them.

The progressive manufacturer wants you to succeed, in order that *he* may. He isn't a philanthropist, but he is too good a business man to destroy his own market.

His success is absolutely dependent upon your success. If the market is demoralized, he is decidedly anxious to find out what and where the trouble is and to correct it.

You and he are about the only ones who can correct it. And the only way to accomplish this is for both of you to get together and understand each other.

Suppose you make a trip to see him, like the Southern banker did. It paid the latter.

WILLIAM A. JOHNSTON.

DETROIT EXCHANGES WAGE WAR ON PRICE-CUTTING PIRATES

In Detroit it becomes at times difficult for certain exhibitors to find bookings. It is noticeable that these exhibitors are the ones who will run five to seven reels for a nickel, eight reels for a dime. It should be remarked that the members of the exhibitors' League are pledged to give but three reels for a nickel, five for a dime, and to discourage in every way possible the giving of more.

Also the exhibitors' League has the backing of the film exchanges in this stand. Now what do some of the pirates do, but buy job lots of old film here and there, secure a regular service of three to five reels from a film exchange, add to this program as many of their job lot films as their generosity will permit, and advertise anything up to ten reels, or the limit of the patience of their audiences for a dime. And they seem to have it over the exhibitor who would protect the business. Probably some of these pirates got the films recently stolen from the office of the Progressive Film Company last week. Manager Ward would like to know who got them.

COSMOS NEW RELEASE NEARLY READY

Following "Hearts and Flowers," the Cosmos Feature Film Corporation will release "The Little Girl That He Forgot." This will be a photoplay in five parts.

Beulah Poynter will appear in the title role of this, her own play. Incidentally it may be mentioned that Miss Poynter has written a novel along the same lines, which will shortly be published.

"Lena Rivers," with Miss Poynter in the title role, is going big wherever shown.

The exact release date for "Hearts and Flowers" will be announced shortly.

ASHLEY WITH THANHOUSER

Arthur Ashley, former Vitagraph leading man, has joined the New Rochelle forces of the Thanhouser Film Corporation. Mr. Ashley comes to his new field of activities with a splendid record of screen performances to his credit.

The first release presented Mr. Ashley will be a two-reel racing picture with plenty of seat-gripping thrills.

EDISON WILL RELEASE THREE CHRISTMAS

"On Christmas Eve," "The Birth of Our Saviour" and "'Twas the Night Before Christmas" are the three films of good cheer the Edison company will release as forerunners of "Merry Christmas."

ARE YOU USING IT? THESE MEN ARE. SEE PAGE 51

"Very good; thanks."—LOUIS SITNEK, Lyric Theatre, Uniontown, Pa.

"I consider it a very good thing."—WILTON J. MOORE, Princess Theatre, Janesville, Minn.

Laemmle Visits New Universal City

President, Accompanied by General Manager Bernstein, Makes Tour of Inspection of West Coast Studios and Expresses Satisfaction with Work Accomplished

Special to MOTION PICTURE NEWS

Los Angeles, Nov. 22.

PRESIDENT CARL LAEMMLE, of the Universal company, and Mrs. Laemmle recently arrived in Los Angeles for a stay of ten days or two weeks. Already there are stories of big things that are to be done at the New Universal City, to be heard on every hand.

From an authoritative source, the office of General Manager Bernstein, emanates the report that four or five new companies will soon be formed for production, which will take up the making of three, four and five reel feature pictures from copyrighted novels and plays for the Universal program. The first of these features will be released early in January.

President Laemmle, in company with Mr. Bernstein, T. D. Cochrane, and other Universal officials, made a visit to New Universal City, a tract comprising more than four hundred acres, where seventeen buildings are now complete, together with a private water and sewerage system, a zoo,

hospital, cafeteria, and a number of California bungalows for employees.

Mr. Laemmle had not been to the west coast since the work of building the first and only city in the world given over exclusively to the manufacture of motion picture was commenced, and every turn of the auto wheel brought new causes for ejaculations of surprise to his view.

After a few hours among the wonders of the new home of Universal pictures, and as the car rolled along the smooth boulevard toward Hollywood, the Prexy of the great motion picture company was heard to remark something about someone having used their brains.

Mr. Laemmle, in company with Mr. Bernstein—who, by the way, was taking his first vacation of two days since taking charge of the Universal studios here eighteen months ago—then went to San Francisco to see the exposition grounds, and visited the California Film Exchange, distributor of the Universal program.

J. C. JESSEN.

Council Bluffs Ministers Want Sunday Closing

Clergymen Meet at Y. M. C. A. and Plan Campaign, But Exhibitors, Conscious of Their Own Rights, Calmly Wait First Move

Special to MOTION PICTURE NEWS

Omaha, Neb., Nov. 17.

NEARLY 100 ministers and church laymen of Council Bluffs, Ia., met at the Young Men's Christian Association building in that city Sunday, November 1, and made the preliminary arrangements for a campaign against motion picture theatres remaining open on Sunday afternoons. The Y. M. C. A. Sunday afternoon meetings have not been a success, it was declared, because the motion picture theatres drew the crowds.

The plan of campaign was merely talked over and a strong committee was appointed to begin the fight at once. The Council Bluffs exhibitors comprise a class of progressive citizens, it was admitted at the

meeting, and nothing whatever was said about their being at fault. One minister eulogized the motion picture industry, telling of its wonderful possibilities for education, but deplored the continuance of the Sunday afternoon shows.

That the Council Bluffs exhibitors can take care of themselves there is little doubt. They have a successful organization, which boosted the admission price scale last winter and made it permanent, to their mutual prosperity. That they can again exert their cooperation to "stick up" for their business cannot be doubted. Although they have taken no steps yet, the various exhibitors said they were ready to maintain their rights whenever called upon to do so.

GUY LEAVITT.

Los Angeles League Wants All Exhibitors

Organization Making Strong Efforts to Bring Theatre Owners and Managers Into the Fold as Active Members

Special to MOTION PICTURE NEWS

Los Angeles, Nov. 16.

AN active campaign has been taken up by all members of the local Exhibitors League, and an effort will be made to induce all theatre owners and managers to become active members of the organization.

With the view of beginning this work a special meeting was called by Judge A. P. Tugwell, the president, and every member in good standing was present.

A report of the state convention was first made by Mr. Tugwell, and in conclusion he paid particular attention to the action taken by the state League with the view of increasing the membership. A motion was made and carried that all officers and mem-

bers of the executive committee act as a committee on membership, and they are now actively at work.

At the special meeting five names were presented for membership: Mike Gore, owner of the Metropolitan, Casino, Plaza and Sunbeam theatres; Manager Hawn of the Academy; William Burns, owner of the Butterfly; H. L. Lewis, owner of the Hollywood; and the manager of the Royal on South Main street. All are of Los Angeles.

It is the hope of the membership committee to be able to present the names of practically two-thirds of the local exhibitors, and following this a campaign will be taken up to induce exhibitors of small cities to unite with the League.

Herrington Plans to Unite Pennsylvania

Harrisburg Organizer Sends Out Call for a Get-Together Convention to Be Held January 4-5-6, with the Intention of Affiliating All Factions of the State with the National Association—Predicts Bright Outlook for Co-Operation of Various Bodies

Special to MOTION PICTURE NEWS

Harrisburg, Pa., Nov. 17.

PENNSYLVANIA is to have an aggressive state-wide organization of motion picture exhibitors which will be affiliated with the Motion Picture Exhibitors' League of America, if the widely laid plans for the get-together convention of men of all local organizations, as well as unattached exhibitors, to be held in this city January 4, 5 and 6, meets with the success that is predicted for it by its promoters.

A significant feature of the proposed gathering is that the convention plan originated with a Pittsburgh local association formerly affiliated with the international organization formed by the bolters from the National League in the New York Convention of July, 1913. This organization is Pitt Local No. 1, of the Motion Picture Exhibitors' League of Pennsylvania, which, however, now declares itself independent of any national body.

Representatives of Pitt Local assert they are now perfectly willing to come back into the national fold. Indeed it is their openly expressed desire that the newly proposed state organization shall be a branch of the Motion Picture Exhibitors' League of America.

Fred J. Herrington, of Pittsburgh, organizer of Pitt Local, who was president of that body when it was a part of the bolting International Association, is here, making preliminary arrangements for the convention. He places particular emphasis on the assertion that the co-operation of exhibitors, no matter with what organization they heretofore have been affiliated, as well as men who have been in no organization, is earnestly sought.

Mr. Herrington is understood to be especially eager to have a full representation of the Motion Picture Exhibitors' League of Pennsylvania at the convention. This body, whose membership is confined chiefly to Philadelphia and vicinity, is understood to hold a charter in the national league, but, it is intimated, has not recently entered with very great enthusiasm into organization work of any kind. Samuel F. Wheeler, of Philadelphia, is president of the League of Pennsylvania, and it is understood to be the wish of the prime movers in the convention plans to gain the benefit of his advice and experience in organizing the state-wide branch of the national league. They are hoping he will attend the convention and lend his influence to promote its success.

Mr. Herrington told the representative of MOTION PICTURE NEWS here that he has received encouraging reports from Philadelphia, and that P. J. Cropper, of that city, business manager of the Exhibitors' League of Pennsylvania, has written him a letter expressing his approval of the state-wide movement and promising to be present at the Harrisburg convention. This assurance that Philadelphia is becoming inter-

ested in the project lends great encouragement to the Pittsburgh promoters, who say they have had absolute assurance of the co-operation of exhibitors in all other populous parts of the state.

If the professed aim of the promoters is carried out, the convention will be a wide-open affair, and no slate of officers and no ready-made steam-roller program of any kind will be prepared in advance, it being the desire that the delegates shall elect whom they please and map out their own working campaign.

Mr. Herrington, who is getting around among the exhibitors in all parts of the state, was a conspicuous bolter from the national organization in the convention in New York in 1913, but declares he is now in absolute sympathy with the officers and with the purposes of the present national body.

"Knowing some of the good things that the national organization has done in the past and appreciating the work of the new president, Marion S. Pearce, of Baltimore, and the Washington (D. C.) executive board member, Fulton Brylawski, I feel that it not only is my duty, but the duty of all who bolted in 1913, to come back into the fold. It also is the duty of all other exhibitors to get together in the national organization and show those men I have mentioned, who did such noble work on the question of the war tax in Washington, that we are with them for one organization."

A circular letter has been sent out to about 1,000 exhibitors from the headquarters of Pitt Local, 115 Fourth avenue, Pittsburgh, which briefly sets forth these advantages. Thousands more will be sent. This circular, after emphasizing the fact that the gathering is to be held under the auspices of both the Motion Picture Exhibitors' League and the Motion Picture Exhibitors' Association, as well as the independent exhibitors of the state, "for the purpose of having one compact organization," adds that the selection of the place and date of the meeting are considered as most appropriate.

Harrisburg is the capital of the state, and it is remarked that at the time of the convention here the state legislature will be convening. A number of measures of vital importance to the exhibitors will come before that body. In referring specifically to measures that will receive the attention of the Pennsylvania law makers, the circular says:

"First, the new building code, if passed in its present form, would work a hardship on all exhibitors and would close not less than 60 per cent. of the picture theatres now in operation in the state.

"Second, the new state laws conferring the power on the boroughs to levy certain taxes, will in all probability work a hardship on our business if we are not there to express our ideas.

"Third, the repeal of the censorship law affecting motion pictures and our advertising paper."

V. H. BERGHaus.

WHERE TO FIND IT

Department.	Page.
Live Wire Exhibitors.....	29
Looking Ahead	31
Among the Exchanges.....	33
In and Out of Los Angeles	
Studios	35
Editorials	39
Feature Reviews	41-47
Program Reviews	48-50
Buyers' Guide	54
Current and Coming Releases,	
52, 53	
Release Dates for Ready Reference	55, 60, 62
ACCESSORY NEWS	103-116

"When I bolted the national organization," said Mr. Herrington, in an interview today, "it was because it was in the control of one or two men and the president was a great apostle of censorship. For this and some other reasons the Pittsburgh exhibitors bolted the old national body. At the Dayton convention many of the evils, including the evil of censorship, were eliminated from the national body, so that things are entirely different now.

Ohio Censor Law Before Highest Federal Court

Mutual Attorneys Will Present on December 7 Arguments in Case Testing Constitutionality of Censorship in All Forms

Special to MOTION PICTURE NEWS

Washington, Nov. 18.

ARGUMENTS in the case of the Mutual Film Corporation against the Industrial Commission of the State of Ohio will be begun in the Supreme Court of the United States on Monday, December 7, the motion to advance this case from its regular place on the calendar having been granted last week.

This case is brought to test the constitutionality, both under the constitution of the United States and of the State of Ohio,

of the act passed by the legislature of the State of Ohio creating a board of motion picture censors in that state. It was pointed out to the court that this case is of the greatest importance to all concerned in the motion picture industry, and to the millions of people of this country who daily go to the motion picture houses, and that the Supreme Court of the United States should decide the question as to whether any government authority can rightfully impose a censorship of motion picture films.

An early decision is earnestly desired.

FAMOUS PLAYERS PRODUCE "THE LOVE ROUTE"

The Famous Players Film Company will shortly begin the production of "The Love Route," by Edward Peple, author of "The Spitfire" and the recent success, "A Pair of Sixes." The film version of this noted modern romance will be produced in the West with Marguerite Clark, the dainty star of "Wildflower," who left last week for Los Angeles, to appear in a forthcoming production for the Jesse L. Lasky Feature Photoplay Company, to which company the Famous Players loaned the services of their star for a limited time. Allan Dwan, of the producing staff of the Famous Players, will leave this week for the coast, where he will join Marguerite Clark and begin work on the production.

WHERE IS JULIUS WRIGHT, FORMERLY OF BERMUDA?

A request has come to the office of MOTION PICTURE NEWS for information concerning the whereabouts of Julius Wright, formerly in the motion picture business in Bermuda. He left there in July, intending to settle in the United States, probably in one of the smaller cities.

Any knowledge of his present location will be gratefully received by A. I. Keeler, 3105 Midvale avenue, Germantown, Pa., who is particularly anxious to communicate with Mr. Wright. If any of our readers knows where the missing man can be found, they are requested to get in touch with Mr. Keeler at once.

CENSORS O. K. TWO ALLIANCE FILMS

The National Board of Censorship, after reviewing the five reels of the new Excelsior Feature Film Company, release "When Fate Leads Trump," from the book of John B. Hymer, made the curt remark—"nothing to cut." "That is the way we like to have things," said William H. Wright. "We ourselves carefully consider every detail of a story before we actually produce it, and do not submit it for approval until we are certain that it warrants that approval."

The National Board also reviewed the Favorite Players Film Company's new release, "The Man Who Could Not Lose," taken from Richard Harding Davis' story of the same name, and passed the entire play exactly as it stands. Both are released through Alliance.

MINOR IN "HOME SWEET HOME"

Frank Minor is a comedian who has earned quite a reputation in various musical comedy and vaudeville successes, principally as the lead in "September Morn," which enjoyed quite a run in Chicago theatres this year.

Mr. Minor was given Dave Lewis' part in the production and was acknowledged by the press to be better than the original. Like many other stars, Mr. Minor is giving some of his attention to motion picture work, having arranged with the American Standard Motion Picture Corporation, of Chicago, to appear in a series of one-reel comedies. His first production, which is to be released early in November, is called "Home Sweet Home."

Milwaukee's Commission Seeks Screen Aid

Civic Body Requests Members of Local Association to Help Promulgate "Safety First" Campaign Through Use of Slides

Special to MOTION PICTURE NEWS

Milwaukee, Nov. 16.

ONE of Milwaukee's biggest and most influential organizations has formally recognized motion pictures as one of the most powerful agencies for educating the people available. The Milwaukee Public Safety Commission, through one of its members, Charles Lamb, appealed to the local exhibitors, at the regular meeting of the Milwaukee Exhibitors' Association, held in the Plankinton House club room, to assist that organization in their "Safety First" work.

Mr. Lamb asked that the Milwaukee ex-

hibitor run in his house a "Safety First" slide, and stated that the exhibitor, reaching as he does thousands of people every day, could assist materially in the "Safety First" campaign. The local exhibitors agreed. They were also asked to appoint a representative to the commission, and they bestowed this honor upon Manager George Fischer, of the Alhambra Theatre.

Great interest is being taken in the annual election of the Exhibitors' association, which takes place December 4. The election promises to be a hotly contested one, as a number of aspirants are in the field for each office.
J. W. MARTIN.

Cosmos the Latest to Join the Alliance Program

Company's First Release Under New Arrangement Will Be "Hearts and Flowers," With Mrs. Thomas Whiffen as Central Figure

FOR a week there has been considerable speculation as to what concern the Cosmos Feature Film Corporation intended to release through, having re-entered the producing field. Word now comes from authoritative sources that the Cosmo productions will reach the public and exhibitor exclusively under the banner of the Alliance Program. It is expected that negotiations will be closed within a few days.

The Cosmos company are to produce and

She has appeared in nearly every great success that has gone to make dramatic history for the last half century.

The part which Mrs. Whiffen plays is that of a sweet old fashioned mother who, through her son's carelessness, rather than badness of heart, finds herself destitute. The young woman to whom the son is engaged when she discovers how cruelly he has treated his mother breaks the engagement, and gives to the old lady the love



MRS. WHIFFEN IN "HEARTS AND FLOWERS" (COSMOS-ALLIANCE)

deliver to the Alliance Program one production in five parts every six weeks. Arrangements have just been concluded whereby the latter concern will release on November 30 "Hearts and Flowers," in which Mrs. Thomas Whiffen makes her debut as a screen star.

Mrs. Whiffen, who now enjoys the distinction of being the "Grand Old Lady of the American Stage," needs no introduction to theatregoers in any part of the country.

which ought to come from the son. But no matter how badly her boy has acted, he is still her boy and his happiness is her happiness. She brings the two young people together and bids them be happy.

POLICE DOGS IN EDISON FILM

Two wolf-hounds that have served on the German police force for five years are being used by Director France, of the Edison company in a two-reel drama.

Cashing in on Europe's War

By Arthur J. Lang

(Export Manager, Nicholas Power Company)

There Always Have Been Foreign Markets, but They Have Been Neglected—The War Has Forced American Manufacturers to Pay Attention to Them, and Made It Easier Than Ever Before to Sell American Goods There—Aggressiveness, Intelligence and Patience All That Are Necessary

BUSINESS is always conducted for the profit there is in it, whether you are selling goods in Bangkok, Siam, or Bangor, Me. There is only one excuse for American film producers going after foreign trade, and that is the profits involved. A tremendous volume of export trade may be of the greatest economic benefit to this country, but no manufacturer is so patriotic—or so foolish—as to attempt to contribute to that volume of export trade at a loss to himself.

It is because the money and effort invested will pay dividends that the film manufacturers of this country in increasingly large number are seeking foreign markets.

The people that inhabit this world are human beings first and citizens of any particular country next. That is why motion pictures have taken a hold on them in every quarter of the globe and why they will pay to see American photo plays. Tastes may differ in various countries, but only on the surface.

Motion pictures are enjoyed in every civilized country, and by that I do not mean—as some of our citizens might think—the United States and some of the European countries. I refer to lands such as China and Japan, which have a civilization older than that of Europe, and the countries in South America, which have, for instance, a literature older than that of the United States, where they do not measure art or pleasure or any other of life's most desirable features merely by the cost but by inherent worth and yet where they are always willing to pay the price if they can get the value.

The Opportunity Has Always Existed

Actually speaking, no opportunity for American producers to sell films abroad has been created by the war, for the very good reason that the opportunity has always existed.

There have always been foreign markets, though practically neglected ones. The war has, however, done two things. It has forced the attention of our manufacturers on these markets, and it has made it far easier than it ever was before to introduce their goods into these markets.

Audiences in Asia, Oceania, Africa and Latin-America have always appreciated American films when they have had the opportunity to see them, which has not been very often. The theatre owners and managers in those parts of the world are just like their brethren of this country—eager to please their patrons—and for that reason have always been possible customers.

But American producers until very recently have not gone after them, have not attempted to show them that American films were at least as good as those obtained from Europe.

In spite of that fact, foreign exchanges and theatre owners have occasionally come to us for films, and usually they have come in the only way they knew how—through the medium of the American export commission houses—because they were not in touch with any of the producers themselves.

The results of the latter business obtained in this way will be referred to further on in this article, but it might be mentioned here that commission houses as a rule have been charging the highest prices for the cheapest, poorest and oldest films they could obtain.

The American Producer's Great Chance

The great chance for the American film producer lies in the fact that the neutral markets have been cut off from their usual sources of supply, or that these sources are now greatly hampered in meeting the demand. The extent to which European manufac-



ARTHUR J. LANG

turers of all lines have been in some cases retarded, and in many cases reduced to nothing, is too well known by this time to require more than passing comment here.

The purpose of this article is the application of these well known conditions to American film producers. The opportunity that has always existed has been magnified a hundred fold. The markets that were always there are now easier to approach.

Foreign buyers of films have been in the habit of buying from Europe, and it would take particularly strong and convincing arguments to make them change to American films under ordinary conditions.

That this would be quite possible for aggressive and enterprising film producers is just as true as it is of manufacturers of many other lines that have been successfully introduced in foreign markets in spite of the keenest kind of competition from European manufacturers who had long occupied a monopoly in the field and in spite,

too, if the fact that aside from such questions as quality, price or excellent treatment by European manufacturers, tradition itself prompted purchasing from the latter by buyers who, as a rule, are as steadfast in their business relations as they are in their friendships. But all this has been changed.

You do not have to argue now with foreign film buyers that American films are easily the equal of those of European make or that you will be found fully as intelligent and as fair in your dealings as are the European producers.

The neutral markets are looking to us to supply their needs, and they are ready to buy our films just as they are ready to buy all other lines with which we are in a position to supply them.

Your principal competitors now are not the European film producers, but your fellow American producers.

Any concern that is willing to devote a reasonable proportion of intelligent effort can market its films, not only for the present, but can put its foreign business on a basis from which European competition will find it impossible to shake it after the war.

Two Methods of Seeking Foreign Trade

In a general way there are two methods of seeking foreign trade.

One is to go after it direct and the other is to sell through—or, more correctly speaking, to—export commission merchants.

The latter is probably the easiest way in ordinary circumstances and the hardest way at present, as commission houses have been seriously affected financially as a result of the war. It is also the most unsatisfactory method at any time.

To illustrate—suppose a large producer sold all his films for use in the United States to a distributor over whom he had no control, that there was no connection between the two beyond that of buyer and seller, and that the producer did not know and had no means of learning to whom the distributor was selling.

This would be considered a most unsatisfactory situation from the standpoint of the producer. If at any time, because of a disagreement over even some minor detail or because the distributor could obtain another line of films at a lower cost, the distributor decided not to handle the first producer's films any longer, the latter would have to start in absolutely fresh in building up a clientele.

This is exactly the position any producer is in who sells to a commission house and imagines he is doing an export business. American manufacturers of many lines have discovered this fact to their sorrow. The most successful exporting manufacturers, regardless of the nature of their product, are those who seek direct trade relations with buyers of their goods in other lands.

FRONTIER LIFE IN "THE BAD OLD DAYS" FROM THE INCE-PARAMOUNT FEATURE, "THE BARGAIN"



THE SHERIFF LOSES

STOKES TELLS HIS WIFE THE TRUTH

UNSUCCESSFUL IN THEIR SEARCH

To say that it is easy to get foreign trade means that it is easy for the man of intelligence, because there are many things to learn, and while much export knowledge may be bought in one form or another, much of it must be learned by experience. Moreover, sound judgment must invariably be used.

There are three essentials to building up an export business. In the order of what I consider their importance, they are aggressiveness, intelligence and patience.

I have known manufacturers who have started an export campaign by advertising and because in reply to inquiries they have not returned intelligent letters telling the prospective purchaser just what he wanted to know, they have declared it was impossible to sell their goods in other countries.

Yet other manufacturers making the same kind of goods have made tremendous successes by following up their opportunities carefully and systematically.

Only Surface Details Differ

It is only in surface details that there is any difference in trying to sell to John Gordon in Boston or to Juan Gonzalez in Buenos Aires.

You make your appeal to the latter in Spanish instead of in English; it takes longer for an exchange of letters consummating a sale of your films to him and longer for your films to reach him after they are shipped. But the sale should be just as profitable to you, and his money, after being translated into United States gold, is just as good as that of John Gordon.

On the other hand, your films are just as valuable to him and just as fresh and interesting to the theatre patrons of Buenos Aires as if they had been projected down there within a few days of their production.

In dealing with Latin-American business men I have found them as enterprising and at least as honest as the business men of this country. They are exceedingly appreciative of anything you do for them and they never fail to show their appreciation by buying from you to the limit of their needs.

Back of the three essentials for developing export business—aggressiveness, intelligence and patience—film manufacturers must obtain knowledge of the markets and make use of that knowledge in a systematic sales campaign. In export trade, as in the domestic field, this requires publicity.

Fortunately for the producers, both publicity and detail information concerning all the world's markets may be obtained from the same source at a minimum expense.

The greatest institution for the development of American exports is the National Association of Manufacturers, which has a well organized foreign trade department, while "Export American Industries," the official organ of the association, is a handsome and well edited publication that reaches all the leading buyers throughout the world.

Value of the Association to Exporters

Mr. Steven De Csesznak, of the association, who is publisher of "Export American Industries" (30 Church street), is an authority on export trade and has been devoting much of his time to the opportunities for the export of American films.

The association has more than 1,500 correspondents in various parts of the world who keep the foreign trade department and "Export American Industries" fully informed at all times as to lo-

cal conditions. The association has a foreign trade library and records that have been accumulating for the last twenty years and which are kept up to date in every particular. This organization also has a translation bureau that is without any qualification the best in the United States.

With publicity and service of this character there is no reason why our film producers cannot start after foreign trade in the right way and conduct it properly at every step of the journey toward export profits.

There are many other moves to be made in the game that space does not permit telling here, such as correspondence campaigns supplementing your advertising plans, etc. But each move can be learned when the time comes to make it, and can be learned in such a way that there is no possibility of mistake.

American producers have foreign markets to sell to; they have an unparalleled opportunity to introduce their goods into these markets; they have unsurpassed advantages for formulating and developing sound methods for the sales attack.

All that they need supply is aggressiveness and intelligence, seasoned with just a little patience, to be rewarded by the merry tune of export profits jingling in their pockets.

PHOTOPLAY AUTHORS START WAR ON SCENARIO SCHOOLS

Special to MOTION PICTURE NEWS

Los Angeles, Nov. 16.

MEMBERS of the Photoplay Authors' League have taken up an aggressive fight on the schools pretending to teach scenario writing. Besides devoting considerable space in the national publication, *The Script*, issued from the office of the secretary monthly, a committee has been appointed to try and stop the schools from advertising. Russell Smith, of the Majestic-Reliance scenario department, is chairman of this committee, and has written to publishers, after investigating the schools, condemning every one. The advertisements appear in all classes of publications except the journals of the motion picture trade.

Another matter being taken up by the Pacific Coast branch is that of campaigning for the Willis Bill which will make possible the application of the copyright laws to scenarios.

KANSAS STATE LEAGUE ELECTS OFFICERS

Special to MOTION PICTURE NEWS

Kansas City, Mo., Nov. 18.

AT the annual meeting of the Kansas branch of the Moving Picture Exhibitors League of America, held in Kansas City, it was decided to hold the next annual at Emporia, which is more centrally located for the benefit of all the members. It was decided that the dues should be 50 cents per month, and among the usual routine of resolutions and suggestions, the conclusion of this branch of the League is that too much melodrama is now being produced.

The following officers were elected: National vice-president, Fred Savage, Hutchinson, Kan., president of the Kansas Branch; W. B. Moore, Galena; first vice-president, E. E. Frazier, Pittsburg; second vice-president, Howard Dull, Augusta; secretary, P. J. Concannon, Emporia; treasurer, W. H. Willey, Mullberry; sergeant-at-arms, Roy Bingson, Lingsborg.

The Evils of the Coupon System

By George E. Carpenter

Coupons Are Literally a Plague in Salt Lake City, Where the Exhibitors and Theatre Managers Are Finding Them Boomerangs to Their Business—Two Years Ago the Town Was the Best "Stand" of Its Size—Today Everybody Is Losing Money

THESE has been considerable discussion in MOTION PICTURE NEWS pro and con (mostly con) on the pass problem. Consequently, as a horrible object lesson, permit the writer to present Salt Lake City.

If Denver is the Nickle city of the West, Salt Lake certainly has the dubious distinction of being the Deadhead city of America.

The scheme is being tried elsewhere, consequently the advice to those about to succumb to the siren tones of the circulation manager's argument, is the immortal one given to those about to marry by the London "Punch"—"Don't."

TWO years ago Salt Lake was the best show town for its size anywhere. Today everybody is losing money because the "showmen" are giving away 40,000 free tickets every week!

And this in a city of 100,000 population!

In the meantime the newspapers advertised the fact that their subscribers could see six new shows each week, provided they brought their coupons to the office and exchanged them for seats.

The writer has demonstrated that it is possible to secure free seats without the coupons, provided there is a coupon on the top of the stack.

Just as an example, he received a ticket on the strength of one coupon and two dentist's ads clipped from the same edition, such was the rush for tickets that the young man dispensing the favors did not have time to check up!

EARLY in the spring when conditions became intolerable, those managers who declined to enter the coupon scheme withdrew their advertising from the offending newspapers—with the usual result, you can't buck the newspapers.

OF course, the theory is that if you give a man a free ticket to your show he will go and become a recruit in the army of boosters.

However, Salt Lake managers have overplayed their hand, and have created a Frankenstein, who will take his amusements solely via the coupon route.

Originally the idea was to issue free tickets for matinees only so that the children could go and then talk over the great show at home across the dinner table, thereby enthusing father and mother, who would promptly go in the evening.

But the man whose business was suffering came in and threw down the bars, and now coupons at the majority of houses are good any old time.

THE writer has no interest in any Salt Lake theatre, and has no axe to grind; he simply has set forth the facts as they appear to the man on the side lines.

Liberty

The Motion Picture Palace.

COUPON NO. 291

Three of these coupons clipped in consecutive numbers will be accepted at THE EVENING TELEGRAM business office, 161 South Main street, in full payment for one matinee ticket to the Liberty theatre.

ONE COUPON IN EVERY ISSUE OF THE TELEGRAM.
Not good Sundays or holidays or after 3 p. m. Saturdays.

American

World's Largest Motion Picture House.

COUPON NO. 291

Clip three coupons in consecutive numbers and they will be accepted at THE EVENING TELEGRAM business office, 161 South Main street, in full payment for one matinee ticket to the American theatre.

ONE COUPON IN EVERY ISSUE OF THE TELEGRAM.
Not good Sundays or holidays or after 3 p. m. Saturdays.

PANTAGES THEATRE

The Home of Popular Vaudeville.

COUPON NO. 281

Three coupons in consecutive numbers may be exchanged at the business office of THE EVENING TELEGRAM, 161 South Main street, for free ticket to the theatre.

ONE COUPON IN EVERY ISSUE OF THE TELEGRAM.
Not good nights or holidays.

FREE

A pair of tickets to night performance, Utah theatre, with every classified ad put in The Evening Telegram.

FACSIMILES OF THE NEWSPAPER COUPONS THAT HAVE PROVED A BOOMERANG AS BUSINESS BUILDERS TO SALT LAKE CITY EXHIBITORS

To provide amusement for this 100,000 people there are one legitimate, one combination, three vaudeville, one stock and eight motion picture houses, three of which seat over 1,000, one nearly 3,000.

To outline events that brought about this remarkable state of affairs would require considerable space.

IN brief, however, a bright circulation manager on one of the daily papers conceived the idea of making an arrangement with a prominent vaudeville house, and the largest motion picture theatre, whereby coupons were inserted in the paper. Coupons clipped on three consecutive days entitled the holder to a seat in the theatre.

In exchange for this privilege, the newspaper gave 500 inches of advertising every 30 days to the party of the second part on the contract.

Naturally the opposition, both in newspaper and amusement circles, got busy, with the result that the list of theatres indulging in the coupon system soon included Pantages and Marcus Loew's Empress, the Utah, the American, the Rex and the Liberty, two vaudeville, one stock and three of the largest picture houses.

The theatres standing pat became the target, until they yelled for mercy. They all came back into the advertising columns, but their ads against the full-page displays, special stories and cuts exploiting the wares of the coupon crowd made a very feeble display.

Marcus Loew's Empress, upon the inauguration of the new policy of continuous photoplays and vaudeville, started out in a fashion calculated to bring the cruel war to a showdown.

Tickets racked for the entire week were placed in the most prominent dry goods store, and all one had to do was to walk into the store and ask for tickets and they were forthcoming, free. Entire families visited the Empress as the guests of the dry goods store, and the police had to regulate the mob outside the theatre every night.

The managers who went so gayly into this scheme are now in the unenviable position of the man who had the bull by the tail—they are afraid to let go.

In the meantime the show business in Salt Lake is a horrible object lesson in frenzied advertising and weekly losses.

He herewith has set forth conditions in Salt Lake City as a warning to any exhibitor who may be approached by his local newspaper on a similar scheme.

If he gets in on any such scheme, his opposition will in all probability tie up with a rival newspaper. Then the rest will follow and chaos will result until only the man with the longest purse will eventually weather the storm.

The coupon system has been operated in Salt Lake for nearly a year past, and has resulted in more bad blood, financial loss and general disorganization in the show business than can ever be repaired.

WHEELER RESIGNS AS HEAD OF PHILADELPHIA LEAGUE

Special to MOTION PICTURE NEWS

Philadelphia, Nov. 18.

Mr. Wheeler, owing to press of duties as state president, has resigned as president of the Philadelphia League. As yet no successor has been elected.

There is talk of an Exhibitors' ball early in December, but plans are as yet in abeyance. A decision will be probably reached at the next meeting of the League.

California Organizer Increases Membership

Cory, State Secretary, Makes Five Hundred Mile Auto Trip and Brings Into the Fold Four-fifths of Managers Canvassed

Special to MOTION PICTURE NEWS

San Francisco, Nov. 16.

STATE censorship of the same order as that now effective in Ohio, Sunday closing of all theatres and places of amusement, and prohibition of children under sixteen years of age from attending motion picture theatres unless accompanied by their parents or legally appointed guardians are provided in bills now prepared which will be introduced at the next session of the California Assembly meeting within the next few months.

In fact, the bills have been printed and placed on file for public perusal as required by a California law.

With this fact known exhibitors generally are waking up to the need of a perfect organization, composed of all the motion picture theatre owners, and in the campaign now being conducted by W. A. Cory, state secretary and organizer, it is believed fully 80 per cent. of the exhibitors will be induced to become either members of the League at large or affiliate with one of the five locals.

The campaign has been in progress now three weeks. Mr. Cory recently left San Francisco for an over-state auto trip, to take in practically every city or town in which there is a motion picture theatre. The first week was spent along the Pacific coast, between San Francisco and Los Angeles, during which time he visited every exhibitor in towns along the Southern Pacific Railroad, covering a distance of more than five hundred miles, and securing initiation fees and advance dues from four-fifths of the men he saw.

Arriving in Los Angeles, Mr. Cory, in company with Judge A. P. Tugwell, president of the Los Angeles local, visited cities outside of Los Angeles and in Los Angeles county, and secured applications for membership from practically all the exhibitors.

At the regular monthly meeting of the local League preliminary plans were made for work here in this city. As all arrangements could not be made at this meeting, another was held later at the office of President Tugwell, when it was decided to call a meeting of all exhibitors, by explaining in detail just what legislation is known to be pending, and at this meeting to unite all factions and theatre men in the one organization, the League.

All members of the Theatrical Managers' Association, affiliated with the national organization perfected by the Box Office Attraction Company, and all downtown exhibitors who have recently formed an organization for the purpose of keeping all from paying extra charges demanded by one exchange for two-reel comedies, will be invited to attend this meeting and unite with the League.

Every member of the League as the present time is serving on a committee for new members, and within the next few days it is expected that a majority of the local theatre men will become members.

"As MOTION PICTURE NEWS has said editorially, time after time," President Tugwell told the members of the League, "or-

ganization is the only means for us to save our business. In other sections just such conditions as confront us now have caused exhibitors to see the need. The time is ripe and we are going to have the greatest League of any state in the union by the time the Assembly of California is called to order."

FAMOUS PLAYERS WILL RE-OPEN COAST STUDIO

The Famous Players Film Company have effected plans to re-establish their studio in Los Angeles, where they operated all last winter and Spring, and where were produced such Pickford classic as "Hearts Adrift" and "Tess of the Storm Country."

Albert A. Kaufman, studio manager of the Famous Players, has left for Los Angeles, where he will take command of the producing force and manage the studio. En route to the coast Mr. Kaufman will stop off in most of the principal cities to study film conditions as they apply to the Famous Players program.

Marguerite Clark will be the first Famous Players star to appear in a subject produced at the Western studio, plans for her presentation in "The Pretty Sister of Jose" having already been consummated. Allen



ALBERT KAUFMAN

Dwan, of the producing staff of the Famous Players, will accompany Mr. Kaufman to the coast studio, where he will be stationed.

ECLAIR IN MARKET FOR SCENARIOS

The Eclair Film Company, Inc., whose producing forces are located in Tucson, Ariz., is in the market for good one-reel Western comedies, and one and two-reel Western dramas.

The company is not in a position to film scenes calling for bodies of water or elaborate costuming.

All scenarios should be addressed with stamped envelope for return, to the scenario department of the Eclair Film Company, Inc., 126 West Forty-sixth street, New York City.

ESTABROOK JOINS FILM RANKS

Howard Estabrook is the latest of the Broadway stars to join the ranks of the photo-players. Mr. Estabrook plays the lead of Travers Gladwin in George Kleine's film version of the Cohan and Harris success, "Officer 666."

Mr. Estabrook has appeared under the management of William A. Brady, David



HOWARD ESTABROOK

Belasco and others. He counts among his successes the male leads in "Within the Law," "Divorcons," and "The Vanishing Bride." Mr. Estabrook has been identified with many other Broadway productions, including William Collier in "The Dictator," Blanche Walsh in "The Straight Road," Arnold Daly in "The Boys of Company B," Joe Weber in "Hip Hip Hurray," Holbrook Blinn in "The Boss," Grace George in "Jim's Marriage," and Cyril Scott in "The Fatted Calf."

SAN DIEGO FIRM IS MAKING LOCALS AND INDUSTRIALS

Stineman and Farr, San Diego, Cal., have been making local event, industrial and educational films for the Chamber of Commerce of that city and also for the Panama-California Exposition, to be held in 1915, celebrating the completion of the Panama Canal.

The Maya Film Company has just been incorporated to absorb the interests of the two men, who were engaged as commercial photographers, with offices in the Timken Building, San Diego.

It is the intention of the new company to do commercial work, including industrial films. In addition to this the company will produce travel and animal pictures, taken in the tropics.

The firm has in preparation a picture of a spectacular nature.

BELMORE WILL REMAIN WITH VITAGRAPH

In denial of the reports that he had arranged to direct for another company, Lionel Belmore states most emphatically that he will resume his directorship with the Vitagraph Company as soon as his present theatrical contract expires.

LIVE WIRE EXHIBITORS

EDITOR'S NOTE.—It is the desire of "Motion Picture News" to include under this heading novel advertising ideas, successful schemes in the management, decoration and equipment of the theatre—everything, in fact, done by the exhibitor to stimulate his trade. We invite every exhibitor to write us about any new enterprise he has; also to come to us for advice or information along any line. Address: Editor, "Motion Picture News," 220 West Forty-second Street, New York City

THE GLAMOUR OF A FIVE DOLLAR GOLD PIECE

THE Crystal, on State street, New Haven, Conn., believes that there is no better way of drawing patronage than by offering inducements in the form of cash.

Accordingly, each week sees in that house a drawing for a five-dollar gold piece. Thursday afternoon is set aside regularly for this drawing, and as a rule the theatre is well filled. Mr. Mongillo, proprietor and manager of the house, has shown himself to be an enterprising business man time and again, and is finding that his various boosting schemes are bringing results.

PLAIN BUT EFFECTIVE FOLDERS FOR COMING PICTURES

THE Orpheum Theatre, Canton, Ohio, has worked out the individual problem of local advertising by the use of plain but effective announcements for distribution among the audience.

The management has tried with great success a four leaf folder of buff colored paper containing brief descriptions of coming films. Care has been taken to avoid anything gaudy in its make up. Striking type telling in a few words the main points of each picture, and insures the attention of the public.

THREE SHEETS LARGE ENOUGH FOR THIS EXHIBITOR

DESPITE the fact that every other motion picture house in the downtown district of Washington, D. C., is flying or displaying huge posters, the Leader favors the small 3-sheet displays.

"It is only quite recently that I have used the 6-sheet poster, and then I only use one such display against the inner wall of the theatre. I don't care for it myself, but the public seems to wish it. I have no desire to hide the artistic lines of my theatre front with posters," said Nat Glaser, manager of the Leader.

USES VACANT STORES FOR LOBBY DISPLAYS

THE West End Lyric theatre, Kingshighway and Euclid avenue, St. Louis, which is in the extreme west end of the city, calls the attention of the crowds in the downtown shopping district to its program by a display of photographs of the screen players in its daily bill, which are mounted in lobby frames and set up in the windows of vacant stores.

REDWOOD TREES FOR LOCAL COLOR

THE management of the Broadway theatre, Oakland, Cal., has signed a five years contract for the Alco program. In honor of the opening of Ethel Barrymore in "The Nightingale" the

Jane" for one week, playing to capacity business. A picture has never been presented in the Broadway before for a longer period than four days.

Appreciation of Beatriz Michelena in



THE LOBBY DISPLAY FOR "SALOMY JANE" USED BY THE BROADWAY THEATRE, OAKLAND, CAL.

house was especially decorated. For "Salomy Jane" a setting of redwood trees was provided throughout the house.

The exterior shows the use which was made of them. The Broadway theatre presented Beatriz Michelena in "Salomy

"Salomy Jane" is not confined to the West by any means. At the Ziegfeld theatre in Chicago, "Salomy Jane" had a three weeks run and played to capacity business. Equal records seem to be in store for this picture in other localities.

AN EXHIBITOR'S MANIFESTO TO HIS PATRONS

CHARLES M. A. SMITH, managing the Adele Theatre, which opened at Eatonton, Ga., on November 2, starts his house off with a printed program that would do justice to most any concern. Mr. Smith presents a sixteen-page program, bulging with advertisements that must more than pay for the expense of getting it out.

In announcing the policy of his theatre Mr. Smith says: "We will endeavor to create always—to offer at all times—only such entertainment as will be consistent with the dignity of American manhood. Our house is a theatre for mothers, daughters, sisters and wives, where the purity of their thought will be conserved above all things."

An enterprising feature of the program is the following warning, conspicuously displayed:

"WARNING.—Always bear in mind that

in all of the accidents that have happened in opera houses, halls, etc., more people have been injured because they lost their heads and attempted to rush out of the building instead of walking out of the exits than have been otherwise burned or injured. In case of accident or anything else in a public building—WALK, don't run or rush to get out.

"This building has exits on three sides, and the entire house CAN BE VACATED IN LESS THAN TWO MINUTES if you follow this advice—WALK—as we have, in the construction, the world-wide slogan of 'safety first' worked out to the limit."

AN EXPERIMENT IN HIGHER PRICES

THE management of the Mary Anderson theatre, Louisville, is experimenting to determine how higher-priced motion pictures will appeal to the public

Philadelphia Ball Set For December 8

Exhibitors at Special Meeting Decide on This Date for Their Second Annual Function, to Be Held in Horticultural Hall

Special to MOTION PICTURE NEWS

Philadelphia, Nov. 18.

At a special meeting of the Exhibitors' League it was agreed to give the second ball of the league on Tuesday, December 8. Jay Emanuel, manager of Ridge Avenue Theatre, in spite of his protests, was made chairman of the ball committee.

Mr. Emanuel is determined to make this ball even more successful than the one held last year.

The affair will be given in Horticultural Hall, one of the largest and most attractive ballrooms in the city.

The committee appointed to assist the chairman is as follows: Nat Fisher, Michael J. Walsh, David Sablosky, J. Pollon, M. Speirs and Jack Delmar.

Already several pages of the program have been taken by advertisers, and a great many of the ardent motion picture patrons have signified their intention of being present

at the ball in order to meet their film favorites.

A large delegation from the Lubin company will attend, and it is expected that many other photo-players working in the east will be present on this occasion.

The Reel Fellows' Club had a very enjoyable time on Wednesday evening. As the guests of C. L. Perry, their president, and general manager of The Stanley Company's theatres, they were tendered a box party at the Globe Theatre, a recent addition to the vaudeville and motion picture field.

After the performance the club adjourned to its rooms on Arch street, where the evening was rounded off with song and story and other refreshment. The announcement that Mr. Perry would give these parties every few weeks was received with satisfaction by all.

IRENE PAGE SOLOMON.

and is charging 20 cents for admission to the night show. This theatre is showing nothing but feature films of the United Booking Office. Beginning this week there will be a split program every week, the same pictures being exhibited on Sunday, Monday and Tuesday, with a change beginning Wednesday.

The night attendance so far has been satisfactory, which seems to bear out the opinion of the management that Louisville people will not balk at paying 20 cents to see a good show.

The first program of motion pictures, especially for school children was given at the Mary Anderson Saturday morning. Educational, comedy and drama films were shown and a ventriloquist from Keith's theatre was an added attraction. The idea of having a special show for children proved to be a great success and the house was crowded. Two shows for children will be given every Saturday morning.

EDISON ENGAGED FOR "ON THE NIGHT STAGE"

Heralding the realization of his plans to exploit on the screen the stellar lights of the American theatrical world, Thomas H. Ince, general manager of the New York Motion Picture Corporation, will present shortly Robert Edeson in a gripping five-reel feature of western life, under the title of "On the Night Stage."

The piece is the result of joint efforts on the part of Mr. Ince and his collaborator, C. Gardner Sullivan, and is declared to be the acme of perfection in the production of western dramas.

No pains have been spared to make Mr. Edeson's appearance under the management of Mr. Ince one of unequalled elaboration. The 18,000 acre ranch of the company in the Santa Ynez canyon at Santa Monica, Cal., provided the settings, for which the western atmosphere demanded by the story are unsurpassed.

Mr. Edeson was supported in his work by W. S. Hart, who was also specially engaged, Rhea Mitchell and Herschel Mayall.

MARY PICKFORD TO LEAD GRAND MARCH

It is practically decided that Mary Pickford will lead the grand march of the annual ball of the Screen Club scheduled to take place at the Hotel Astor on Thanksgiving Eve.

Numerous applications for tickets have been received by the entertainment committee, and the affair this year will in all probability have a larger attendance than ever before.

NEW BOOK ON SCENARIO WRITING

A book of interest to the film trade, especially to those who write scripts, has just been issued. It is by Catherine Carr, chief scenario editor of the Kinetophone, and is published by the Hannis-Jordon Publishing Company. The publishers predict a ready sale for the volume, which is called "The Art of Photoplay Writing," and look for a big edition.

"Little Lord Fauntleroy" a Juvenile Classic

All Traditions of the Various Roles in the Drama So Well Established Its Screen Reproduction Was Easy for Producers.

"LITTLE LORD FAUNTLEROY" was for years so popular in the legitimate that all matters connected with the proper presentation of Mrs. Burnett's classic of child life were well established. Consequently the producers of this new Alco release had an advantage which the producers of other film dramas often do not have.

For instance, just how the Earl of Dorincourt should be played has been worked out in the regular theatres by numerous actors

H. Agar Lyons as the Earl of Dorincourt, the fiery old grandfather, has produced as fine a type as any of his predecessors in the legitimate. The "Dearest" of Miss Jane Wells is thought by those who have seen the picture to be a sweet and wholesome characterization, well in keeping with tradition. It has a tenderness of its own. Silas Hobbs, Mary Thomas and all the rest appear as old friends.

In the regular theatres sometimes a boy



SCENE FROM "LITTLE LORD FAUNTLEROY" (Alco Feature)

and stage directors, and the public has been called upon to put its seal of approval or disapproval upon their efforts. Dorincourt, Mr. Hobbs the grocer, Thomas the butler, Higgins the tenant farmer, and "Dearest" are all well established types in the legitimate theatre.

played Fauntleroy and sometimes a girl. About young Royston's characterization there is a certain suggestion of the freshness of youth which the girls of the legitimate were not able to give. Little Royston's work is said by film men to be quite as delightful as that of any in the park.

Looking Ahead With The Producers

"Mrs. Wiggs" Soon Ready for the Public

THE Alco Film Corporation announces November 30 as the date for the release of Beatriz Michelena in "Mrs. Wiggs of the Cabbage Patch," the second production of the California Motion Picture Corporation. The films have just been received and were shown privately in the projection room of the releasing corporation.

Those who have seen this second production say that the great success of the

asleep. A locket in King's possession establishes the identity of Lovey Mary as the heiress. It is necessary above all else for her to obtain this locket without arousing King.

The strong dramatic element is continued in the capture by King of Lovey Mary, after Stuart is out of the way. She is hidden in the cellar of a resort, a prisoner behind steel doors. Stuart is on the trail,



SCENES FROM "MRS. WIGGS OF THE CABBAGE PATCH"
(California Motion Picture Company's Next Release Through Alco)

first California production, "Salomy Jane," will be duplicated. The star is the same, the photography is just as effective and the same artistic supervision is responsible for "Mrs. Wiggs."

The photoplay was founded upon Anne Crawford Flexner's dramatization of Alice Hegan Rice's novels, "Mrs. Wiggs of the Cabbage Patch" and "Lovey Mary." By special arrangement with the Liebler Company, the California Motion Picture Corporation is enabled to present this picturization.

A strong cast supports Beatriz Michelena. Blanche Chapman, who played Mrs. Wiggs in the Liebler production, is in the title role in the photoplay. She was sent to the California Motion Picture Corporation by the Liebler Company. Andrew Robson, who was Yuba Bill in "Salomy Jane," is Hiram Wiggs, while House Peters, who was "the man" in "Salomy Jane," is Bob Stuart.

The circus scenes are barely mentioned in the legitimate drama, but in the photoplay they are shown in detail. They furnish, in fact, the beginning of a series of absorbing adventures. These concern Lovey Mary and her small charge, Little Tommy. Lovey Mary is detained by King, the owner of the circus, who is her uncle by marriage.

One of the strongest scenes in "Mrs. Wiggs" is that in which the girl creeps into the wagon in which King and his wife are

however, and finds that she is a prisoner. He disguises himself, gains admittance to the resort. Then follows a series of fights in which Peter's work is as effective as in "Salomy Jane." He forces his way through the doors and then encounters King and his aides. These he dispatches one by one.

The producers have made this fight as realistic as possible. They leave nothing to chance, and have worked the details out carefully. The result is that the fight appears very natural. These scenes were not in the play when it was shown in the legitimate theatres.

They are shown with a rapid change of scene and quick movement possible only in a photoplay.



CHARACTERISTIC SCENES FROM KLEINE'S SCREEN VERSION OF "OFFICER 666"

PICKFORD WILL PLAY "DAWN OF A TOMORROW"

The Famous Players Film Company have just secured the film rights of another important dramatic success, "The Dawn of a Tomorrow," the great drama of an oppressed girl's splendid faith and triumph, by Mrs. Frances Hodgson Burnett, which will be utilized as a vehicle for Mary Pickford.

"The Dawn of a Tomorrow" created a distinct sensation on the stage, and is bound to extend its wholesome influence in a much further direction as a photoplay. Mary Pickford may well be expected to make the beautiful characterization of Glad an artistic and powerful conception.

"SATAN SANDERSON" TO BE SCREENED BY ROLFE

The well-known novel "Satan Sanderson," by Hallie Erminie Rives, has been decided upon as the next photoplay production of B. A. Rolfe Photo Plays, Inc., to be released by Alco after Mabel Taliaferro in "The Three of Us." The chief feminine role, Jessica, will be played by a well-known star, whose name will be made known later.

FIRST FROHMAN FAMOUS PLAYERS FILM ANNOUNCED

The first release of the Famous Players Film Company in association with Charles Frohman, following the affiliation effected between this company and the celebrated producer last summer, will be John Emerson in the recent theatrical success, "The Conspiracy," a detective comedy-drama.

John Emerson will portray the role of Winthrop Claverling, the eccentric author-detective, originally created by him in the stage presentation of the play. Included in the unusually important supporting cast will be Lois Meredith, an important drawing card in her own right, having been the star of the recent dramatic success, "Help Wanted."

GRANDEE DESCENDANT IN NEXT CALIFORNIA FILM

Don Nicholas Covarrubias, descendant of the old Spanish grantees who ruled California in the romantic early days, and the man who successfully impersonated Don Gaspar de Portola, the reputed discoverer of San Francisco Bay, in the famous Portola festival in San Francisco in 1909, has just been signed by the California Motion Picture Corporation as a film actor. He will appear in the Corporation's next photoplay of early California.

"Don Nick," as his many friends in California call him, is a type. Tall, straight, dignified, a commanding eye, a beard cut in the fashion of the old conquistadores, a skilled horseman, he hardly needs a costume to recall pictures of California's proud rulers "before the Gringo came."

In the Portola celebration five years ago, Don Nick, clad in leather doublet, tall boots, slashed jacket and ostrich-plumed hat, rode a charger through the streets of San Francisco at the head of one of the gayest processions that ever marched through that city. His horse wore a saddle studded with silver dollars.



DON NICHOLAS COVARRUBIAS

Ever since he impersonated Don Gaspar de Portola, Don Nick has desired to repeat the adventurous career of the gallant Spanish explorer before the motion picture camera. Plans are not perfected, but there is more than a possibility that the California Motion Picture Corporation will gratify this ambition. But, at all events, Covarrubias will be shown in the next big film dealing with a western subject.

LOS ANGELES THEATRE OWNER WEDS

Abe Gore, a member of the firm of Gore Brothers, owners of four theatres in Los Angeles, and Miss Ruth Ringer, were united in marriage Monday evening, November 2. The wedding was witnessed by about 50 guests, among them many of the Coast film men.

Lasky Company Releases "The Circus Man"

THE latest production of the Jesse Lasky Feature Play Company, to be released through the Paramount Picture Corporation, is the "Circus Man," with Theodore Roberts, a circus story, typically American, made from the book, "The Rose in the

The "Circus Man," with Theodore Roberts, was released November 19, and will probably be seen for the first time in New York at the Strand Theatre.

The picture was staged by Oscar Apfel, and in order to get the proper circus at-



DAVID DEFIES BRADDOCK, THE CIRCUS MAN

Ring," by George Barr McCutcheon, author of "Brewster's Millions."

In addition to Mr. Roberts, the cast includes Florence Dagmar, Jode Mullally, Monroe Salisbury, James Neill and Mabel Van Buren.

mosphere and the exact locale, Mr. Apfel and the Lasky players journeyed for two weeks with Barnum & Bailey's circus, using the circus equipment each morning for the making of the production. Readers will remember the scene outside the circus tent.

"Cabiria" Rights in Twenty States Closed

Entire Country Soon to Be Disposed of—Werba & Luescher, Lesser, Greene and Fichtenberg Among the Buyers and Bookers

TWENTY states have either been sold outright or the booking rights granted on "Cabiria," the Itala multiple, and active negotiations now in progress promise that two or three weeks will see the whole country contracted for.

Werba & Luescher, Inc., will take care of the bookings in New York and New Jersey. Their office is in the New York Theatre Building. Sol Lesser of San Francisco, will place the super-feature in that territory. W. E. Greene, the New England exchange man, has been entrusted with the New England bookings, to be directed from Greene's office, at 162 Tremont street, Boston.

Frank Samuels has just gone to Chicago to begin operations in Illinois, Wisconsin and Indiana. Mr. Samuels will be particularly remembered for his association with both the first and second Motion Picture Expositions in Grand Central Palace in a managerial capacity.

Harry Bryan will take care of eastern Pennsylvania, Delaware, Maryland and the District of Columbia, from offices at 1316 Vine street, Philadelphia. Mr. Bryan has gained experience as manager of rental offices for W. H. Swanson, George Kleine, All Star Film Rental Company of New York and others.

Louisiana and Mississippi rights have been sold to Herman Fichtenberg, of New Orleans.

Of interest to exhibitors having small houses, is Harry R. River's announcement that, if necessary, the feature may be run as a serial over several days.



SCENE FROM "THE MAKING OF HIM"
(Lubin—November 25)

AMONG THE EXCHANGES

MINNEAPOLIS EXCHANGE NOTES

J. C. GRAHAM, general manager of the Universal, spent a day in town last week. He stopped off en route to Chicago and reported business satisfactory in all the states he visited.

Julius Bernheim, of the Laemmle Film Service, Minneapolis, nephew of Carl Laemmle, returned from Europe last week. He left with the Laemmle party last spring and was held ever since the war broke out. Julius sure has a good many things of interest to tell these days, and he isn't a bit stingy about them, either.

The Annette Kellermann "Neptune's Daughter" Company closed a very successful week's engagement at the Metropolitan Opera House in Minneapolis, November 7. The receipts, according to best obtainable information, ran way above those on "Caboria." The Universal Booking Offices, looking after the Kellermann Company, surely must be very anxious to make a clean-up in a hurry. During the last few weeks not less than five men have arrived from New York to look after the different Kellermann companies and territories all over the Northwest.

E. H. Hoyt and Johnnie Shean are looking after Minnesota and Iowa. Charlie Ringsdorf is in Montana and North Dakota. Armstrong, the latest addition, is here as a sort of special representative. They all agree that business with the Kellermann pictures is excellent.

W. S. Preller, now manager of the World's Film Corporation, has returned after a week's trip to New York, and is now located in his new office.

FOX FILM COMPANY FORMED IN MILWAUKEE

PAPERS of incorporation have been filed by the Fox Film Attraction Company. The company is to be capitalized at \$5,000, and R. C. Fox is named as general manager. According to Mr. Fox, the company will establish offices in this city and Minneapolis. Four of the Box Office Attraction Company's features, "Children of the Ghetto," "St. Elmo," "Life's Shop Window" and the "Walls of Jericho," will be handled by the new company for all of that territory.

ALLIANCE ADDS TO ITS EXCHANGES

THE Celebrated Film Players Company, of Chicago, which handles the Alliance Programme in Illinois, has added Indiana to its territory.

The Zenith Feature Film Company, of Duluth, one of the largest film concerns in the Northwest, has just signed contracts to exclusively control the Alliance output in Minnesota, Wisconsin and North and South Dakota.

KANE NOW WITH WORLD FILM CORPORATION

ONE of the "old heads" of the film business is Arthur S. Kane. His experience has been long, varied and successful. Exhibitor, exchange man and manufacturer, all three branches have been embraced in the activities of Mr. Kane, stretching over the past eight years. Mr. Kane has just become assistant general manager of the World Film Corporation and will assume his new duties on November 30.

"The amounts theatres are willing to pay for films have increased enormously," said Mr. Kane recently. "It merely is a question

rate and he no longer scruples at allotting more than ten or fifteen per cent of his total expenses to film.

"What it will pull into the house and what the after effect will be are now the determining factors, in what the theatre manager will expend. Everywhere houses clamor for attractions of merit and price has become the secondary consideration. One small concrete case will serve for illustration. A friend of mine who up to three or four months ago ran a fifty dollar service now pays more than one hundred and twenty-five dollars each and every week for films. This is typical of numberless theatres."

During the past four years Mr. Kane has held the positions of branch manager, special representative and an assistant to the president with the General Film Company; district manager with the Mutual Film Corporation; and general manager of branches with the Eclectic Film Company.

K. C. BOOKING OPENS CHICAGO OFFICE

THE K. C. Booking Company, Inc., which is handling all of the productions of the Kinetophote, as well as several outside features, has opened an office in Chicago in the Mallers Building, at the southeast corner of Wabash and Madison.

The Chicago office will be under the direct supervision of K. C. Headquarters at 126-132 West Forty-sixth street, New York, and will look after Kinetophote and K. C. business in Illinois and Wisconsin.

HUNTER SELLS OUT TO GOLD, SEATTLE

HARRY HUNTER, who went to Los Angeles in July and opened the Independent Film Exchange, which was later merged with the Union, owned by O. V. Traggardh, has sold his interest to Glen Speck, who has been with the exchange, and has gone to Seattle, where he expects to open an exchange.

Mr. Hunter also owned half interest in the Garden Grove theatre at Garden Grove, Cal., and one at Norwalk, Cal. He disposed of his interests there to his partner, Max Alpert.

LOUISVILLE MUTUAL IN NEW OFFICES

MANAGER FRANK E. HAMMER, of the Louisville office of the Mutual Film Corporation, is now located in his new quarters in the Alamo Theatre building. The Mutual has built up its business considerably in this territory since opening an office here about three months ago.



ARTHUR S. KANE

of how much the pictures will draw into the houses. It was not always that way. Seven years ago a firm I was associated with in St. Louis served a house with three reels of first run changed twice weekly at ten dollars per reel, or sixty dollars for the weekly service. There were periods as long as seventeen straight weeks when the proprietors divided one thousand dollars weekly from that theatre.

"Pretty good results from a sixty dollar film service. Furthermore, this house had been opened on a cash investment of one hundred and forty-five dollars; everything else was paid for out of the box office, that is, from the receipts after it got going.

"What a contrast today. An exhibitor has large sums of money tied up in his plant, fixed charges are going on at a tremendous

ZEELER NOW EXCHANGE MANAGER

SAM ZEELER, formerly head booker of the Universal Exchange, at 23rd street, New York, has climbed to the position of manager of that exchange, taking Mr. Hoffman's place, who is now general manager of the New York exchanges.

Mr. Zeeler has virtually risen from the bottom of the ladder, starting as office boy with one of the small film companies. He



SAM ZEELER

then went with the Empire Film Company, and from there to the Metropolitan company. Leaving the Metropolitan he cast his lot with the Universal, working his way up to head booker, from which position he succeeded Mr. Hoffman as manager of the 23rd street exchange.

WITH THE MILWAUKEE EXCHANGES

THE Imperial Film Company, of Milwaukee, located in the Manhattan building, has been compelled by the increase in business to move into larger and more commodious quarters. They are now located at 401-2 Manhattan building, where they have one of the most pretentious feature offices in the city. Manager L. B. Goulden announces that hereafter they will release from one to three features a week.

Irving P. Rink, the traveling representative of the Wolverine Feature Film Company, is out on a two-weeks' trip through the northern part of the state.

The O. H. Jacobs Film Company is now handling the Apex releases in this state, and reports business as being very heavy.

F. L. Davie, formerly manager of the Wolverine Feature Film Company, has left that company and has turned his attention to Warner's Features, handling them exclusively in Milwaukee.

Arthur R. Wirtenberg has succeeded Davie as manager of the Wolverine.

Balboa Offers \$1,000 Prizes in Gold

Company Will Pay Screen Patrons a Tidy Sum for Correct Guess to Questions Illustrated in Twelve Feature Pictures

Special to MOTION PICTURE NEWS

Long Beach, Cal., Nov. 16.

THE serial photoplay is magnetic because curious Americans, once their interest has been aroused in a story, like to know what becomes of the characters who have commanded their attention. If the first episode excites them, and the action is suspended at a point where the machinations of the villain have dangerously enmeshed the hero and the heroine, no audience will rest content until the rescue is complete. It is a simple matter then to create a continuity of thrilling incidents that will keep thousands in a state of nervous expectation.

The human problem that requires solution—the undecided question that cries for an answer—is doubtless even more attractive than an impersonal regard for the principals in a dramatic cast. This being true, it is beyond dispute that a combination of the two would possess irresistible charm and fascination.

Long before the most celebrated of these serial photoplays were released, H. M. and E. D. Horkheimer, of the Balboa Amusement Producing Company of Long Beach, Cal., were preparing a group of twelve human interest features, each to embrace a vital question of life. The first two of these have been produced and the staging of the others will follow immediately. Their length will vary from two to three thousand feet, and when completed one will be issued every month through a chain of trustworthy exchanges. The first, for instance, will involve a question everybody is familiar with in one form or another. It is an old, old story—as old as love, romance or marriage, but the world has been disagreeing about it ever since the days of Adam and Eve.

Now it must be settled by the motion picture patrons of the United States—settled for once and for all time. It will be propounded in a strong two-reel drama by an all-star cast. The treatment will be a revelation to those who admire superb photography, brilliant scenes and masterful direction, and while ranking the very best and most absorbing features of the day, this photoplay will at the same time elucidate a mighty question that is begging the world for an answer. A trailer at the end of this potent picturization will ask "Who Pays?"

Motion picture patrons of the country must say and to stimulate their active participation the Balboa Company will give one thousand dollars in gold for the nearest correct answers to the simple questions that the twelve features will illustrate. More than one year has been spent in assembling the manuscripts which have been contributed by a dozen of the best writers on this side of the Atlantic.

Deep and continuous thought has been devoted to making these plays, each rife with intensity, superior to anything the Balboa Company has so far turned out. Twelve separate and distinct plots embodying twelve unrelated themes, are not easy to obtain, but they were secured by reading fully two thousand scenarios sent in from all over the country.

After the selections were made came the work of building and painting special scenery, hunting suitable locations and carrying the many important details connected with such a vast undertaking. The Balboa Company is now producing the ten remaining plays of this series and the public may look forward to a novel motion picture treat in the very near future. The company will not disappoint them.

ALLIANCE EXCHANGE IN BROOKLYN

FOR the convenience of exhibitors on Long Island the Alliance has opened a fully equipped exchange at 1482 Broadway, Brooklyn. H. Grossman will be in charge and invites all his friends to drop in and give him the "once over."

This exchange will take care of Brooklyn, the entire of Long Island and will also be at the service of the exhibitors on Staten Island.

As a beginning the Norwood and Duffields theatres have signed yearly contracts for the Alliance Programme. In Manhattan the Odeon, New Law, and Palace theatres have joined the Alliance ranks. Last minute reports from out of town add to this list the Venice of Flushing, Proctor's Troy, Park in Glen Falls, and the Central Park of Buffalo.

WORTHINGTON WITH BOX OFFICE IN QUAKER CITY

THE Greater New York Film Rental Company, Philadelphia, of which Jack Levy is manager, has taken on the Standard releases. Beginning November 10, the Lubin serial, "The Beloved Adventurer," will be handled by this company.

C. L. Worthington will succeed J. A. Levy as manager of the Box Office Attractions. Mr. Worthington comes from Washington, where he successfully conducted the Washington branch of the Electric Film Company.

Previous to that, Mr. Worthington was the first manager of the special feature department of the General Film Company, in New York City.

ALCO WITH GOLDEN GATE IN FRISCO

THE Alco Film Company has decided not to occupy the new quarters recently selected on Eddy street, but will establish headquarters with the Golden Gate Film Exchange, 234 Eddy street, San Francisco, Cal. The offices at this location are being remodeled, and additional space has been secured for the reception of film and poster stock.

VINE STILL AT BOSTON OFFICE

CONTRARY to the statement recently published, F. H. Vine, manager of the Eclectic Feature Film Exchange at Boston, has not resigned and is still on the job for Eclectic.

In and Out of Los Angeles Studios

Special to MOTION PICTURE NEWS

Los Angeles, Nov. 16.

GRETCHEN LEDERER, who will play leads for the Frank Lloyd Rex Universal brand, is a graduate of the Cologne Conservatorio, where she studied for grand opera. After finishing the course she made a season's tour in America.

Here the lure of the picture camera proved to be too strong. She has since placed with Selig, Imp, German Kinemacolor and the New York Motion Picture Company producing companies. Her first appearance in the revolving globe pictures is that of Delphine, Duchess of Lutzelburg, in the Terrance O'Rourke picture, "Inn of the Winged Gods."

With the mercury playing up about the one hundred mark the Otis Turner Special Feature Company members during the past week frolicked in a Siberian snow storm at the Universal studio, in the making of "Called Back," a three reel picture from the Hugh Conway story.

The greatest difficulty the players had in preserving realism was to prevent the perspiration from showing while being bundled up in heavy cloaks, fur caps, robes, etc., during their ride into a specially built Siberian village in a sleigh drawn by four horses. Several tons of salt and five wool-bags of confetti were used for the storm. The picture has been shipped East.

Sidney Ayers is a new member of the Universal directing company, with Tom Walsh as assistant director and Edna Maison playing leads. The first picture will be "On Desert Sands," with decidedly Western atmosphere.

Last Custer Survivor in Films

Alfred L. Chaplin, who has federal war department proofs that he is the only survivor of the Custer Massacre and who personally made a report to General Grant of the famous battle, has been engaged to play a featured part in a two-reel Western picture to be produced by Henry McRea at the new Universal City ranch.

Calder Johnstone, of the Universal scenario department, is spending a week with the Robert Leonard "Master Key" company now filming dock and marine scenes near San Francisco for the fourth, fifth, sixth and seventh installments of the serial by John Fleming Wilson.

Leigh Smith, formerly in charge of the Cleveland National Forest Reserve in Southern California, has been employed to supervise Universal City. Only native plants and trees will be used. Arrangements have been made for two thousand trees of pine and red wood. The California lily, poppy and violet are to be used in the flower beds.

Marie Walcamp, of the 101 Bison U Company, was painfully clawed by King, the big lion at Universal zoo, last week, when

the beast struck her shoulder with his hind foot while jumping over her body during the making of a picture. Five stitches were required.

The newly organized Rex company, directed by Frank Lloyd, began the production of its first picture, "The Gambler," last week. In this Lloyd played the name role, supported by George Larkin, of "Trey o' Hearts" fame, Gretchen Lederer, Helen Holmes and William Robbins. The scenario is by Ruth Ann Baldwin and the picture will consist of two reels. In this is shown that the better side of a man's



GRETCHEN LEDERER

nature, no matter what his vocation or environment may be, will on proper provocation predominate. It is a pretty story of good and evil playing against each other.

Director Lloyd Ingraham, of the U studio, has been trying a comedy for diversion, producing "Fatty's Infatuation" with Willard Gardner, Gertrude Short and George Court playing the leading parts in the love frolic. This picture will be released under the Joker brand.

The other Joker comedy made during the week was "A Mixed-up Honeymoon," under the direction of Allen Curtis.

ARE YOU USING IT? THESE MEN ARE. SEE PAGE 51

"We think the form proposed would be very useful to the careful exhibitor." MR. W. L. HEMENWAY, Picture Parlor, Wellington, Ohio.

"I think it just the thing; cannot see how it could be improved upon. Am using the one you sent."—C. E. ADAMS, Palace, North Baltimore, Ohio.

Charles Ray and Enid Markey are playing the leads in "The Fortunes of War," a picture of the Mexican revolution being filmed at Inceville by Jay Hunt. The plot pertains to the efforts of an American to win the hand of a senorita whose father is opposed to the match. The picture will have a number of thrilling rides and hand-to-hand combats with swords and guns.

Scott Sidney has just put over "A Confidence Game" at the New York Motion Picture studio, in which a fortune teller and a fake detective agency frame-up on a wealthy merchant who breaks with his son because of the latter's marriage. But the frame-up proves to be a weak one, and instead of being lucrative for the crooks, brings about a reconciliation of the family.

Inceville Superintendent Weds

E. H. Allen, general superintendent of the New York Motion Picture Company studio, and Miss Margaret Thompson, leading woman at the studio, culminated a pretty romance that began early this year, when Mr. Allen saved Miss Thompson from drowning, by their marriage, November 16. The actress was swimming in the ocean in front of the studio when she was seized with cramps in her right arm. Allen, in his office near the beach, heard her cries for help.

The superintendent did not hesitate to remove his shoes, but plunged into the water and succeeded in swimming to the shore with the unconscious girl. Mr. and Mrs. Allen have been presented with a handsome silver service by the members of the Inceville producing companies.

Charles Swickard, formerly connected with several big Eastern theatrical organizations, has been added to the Inceville force of directors, increasing the total number now working there to eight. Mr. Swickard is now filming a story of the Kentucky hills.

"The Panther" and "In the Land of the Otter" are two pictures of the north woods just completed for the New York Motion Picture Company's brands by Walter Edwards. The first has to do with the tortures suffered by a young hunter at the hands of a despot of the wilderness, in which Frank Borzage, Walter Edwards and Louise Glaum play the principal parts. A pretty picture of the sacrifices of a man of the timber land and trapping country are featured in a romance "In the Land of the Otter."

Universal City Adds Three Policemen

Los Angeles has added three mounted police to its force for patrolling New Universal City, the new officers are under the jurisdiction of the city department and the only difference in the uniform is that "U. C. M. P." appears on their caps.

In the making of "The Flower of the Desert," at Inceville, a new house, built for

the occasion, was destroyed by fire. In this the principals are Leona Hutton, J. Barney Sherry and Harry G. Keenan and the direction was in charge of Scott Sidney. The story deals with the domestic difficulties of a lowly woman and her dope-fiend husband who desert their child which is rescued.

The interest in writing scenarios the country over can be judged from the number of requests F. M. Wiltermood, scenario editor at the Balboa studio, Long Beach, receives daily. Mr. Wiltermood has prepared a sample sheet from a working script and on the opposite side of this gives instructions relative to writing scenarios. His dissertation is a very helpful one, and while frowned on by some writers has been very favorably commented upon by newspaper and trade paper writers.



NEW UNIVERSAL CITY STAGE, 160 x 360 FEET

Ethel, the stenographer of the "Bill" series, of the Mutual program, in number twelve now being made, thinks she is getting wealthy for sure, when she receives checks of big denomination. But it is learned the sender is an escaped maniac and not one of her employer's clients as the name indicates. The title of this Bill is "Mr. Hadley's Uncle." Eddie Dillon is directing with Fay Tincher, Tammany Young and Tod Browning in the cast.

"The Forest Thieves," made by Arthur Mackley of Reliance release, mixes the love making of a young ranger and the post-mistress with a plot of a wealthy lumberman to bride the forest supervisor to make dummy entries so that valuable timber can be stolen. Bob Burns, George Seigmann and Florence Crawford play the leading parts. The story is by Arthur Chapman.

"Love and Business," featuring Fay Tincher, made by the Eddie Dillon Komic company, portrays the sending of a love note intended for wife to an old maid, and the brief business letter meant for the spinster being received by the wife, and the complications that arise from it. The blame is finally placed upon the bonthead messenger.

Based on Trowbridge Poem

The poem of John T. Trowbridge, "Dorothy of the Garret," has suggested the idea for "Old Maid Dorothy," a two-reel picture made for Majestic by John B. O'Brien. Blanch Sweet plays the lead part, a sweet tempered, lovable old maid, who recalls the romance of her youth when she finds the old spinning wheel in the garret. The cast includes Jack Conway, Spottiswoode Aitken, Mary Alden and Billie West.

"The Cost of Crime," is the title of a Balboa feature produced by William S. Taylor. This picture consists of four reels

and features Daniel Gilfeather, the veteran character actor, supported by Henry King, Jackie Saunders and Gordon Sackville.

Some new ideas in visions and dissolves were introduced in the making of "The Seal of Time," at the American studio, Santa Barbara, under the direction of Henry Otto. This is a two reel picture, the principal parts of which are taken by Winnifred Greenwood, Ed Coxen, and George Fields.

Al E. Christie is home from his jaunt in the east and is the busiest man on the Universal lot. For the second Nestor comedy company he has selected Billie Rhodes, Jack Dillon, Harry Rattenbury and Stella Adams, and retained all his old favorites Eddie Lyons, Lee Moran and Victoria Forde for the other company, which will be directed by Eddie Lyons under the supervision of Mr. Christie. Two comedies are to be made each week.

Manager Thomas Persons of the Selig studios is expected home this week from a vacation trip spent in the East. During his absence Colonel W. H. Selig, himself, took personal charge of the producing plants.

Makes Arrangements for Ball

Manager Charles Stillwell, of the Silver Palace Theatre, San Francisco, and vice-president of the newly organized Screen Club of that city, was in Los Angeles making arrangements with local photoplayers to attend the first annual Thanksgiving ball of the club at Frisco Saturday evening, November 28. Mr. Stillwell was very successful here and has the promise of a large number of the popular screen stars that they will attend the ball.

Max Figman has stepped into the duties of directing himself and players of the Masterpiece Film Company in future releases, owing to Marion De La Parelle filing his resignation. In this work Mr. Figman will be assisted by Elliott Clawson, who will also write the scenarios.

Seymour Hastings has been selected for the position of technical director for the company and Ray Hill manager of the office of the producing company. The second subject of the company, "The Truth Wagon," a newspaper story, is well under way. For this picture local newspaper managers have granted the company use of any part of their offices for the making of scenes, and the managing editor of one paper has materially aided the photoplayers in making the picture true to life.

Elsie Janis was busy every day last week in the making of her first picture, under the direction of Phillips Smalley, of Bosworth, Inc. Up to this time the name for the picture has not been decided upon. The scenario is from a story by Miss Janis and will consist of four reels of comedy, in which the daughter of a deceased millionaire falls in love with an artist (Courtenay Foote) while attending a private school for girls.

The infatuation results in an engagement. When her guardian (Herbert Standing) learns of this he calls her attention to the clause of her father's will which provides that she shall not see or hear from her intended husband for six months prior to marriage, on pain of forfeiting the estate. The lovers comply with the clause.

Macklyn Arbuckle recently arrived at the

Bosworth studio and work was begun on the preparation of the scenario for the first picture in which he will appear. The story is by Mr. Arbuckle and the scenario will be prepared by Lois Weber, who will have charge of the filming of the feature.

"The Whip" Star Opposite Arbuckle

In the film Mr. Arbuckle will play the role of such a type as "The County Chairman," in which the gentle side of the stern man of affairs will be brought out. Frank Elliott, the well known English actor, who starred in the London presentation of "The Whip," has been selected to play the heavy leads opposite Mr. Arbuckle.

Hobart Bosworth has been confined to his home with nervous prostration brought on by an acute attack of neuralgia and weeks of over work at the studio. It will probably be some time before he can resume his work and finish the production of "Buckshot John," from the story of the same name by Charles Van Loan, exteriors for which were made at Manning, Cal., during the past few weeks.

Director Oscar Apfel, Dustin Farnum, and company of twenty-five players spent the past week near San Francisco, where exterior river scenes for "Cameo Kirby," the December 24 release of the Jesse L. Lasky Company, were made along the



RHEA MITCHELL

Sacramento River. At this point the river greatly resembles the Mississippi, and with semi-tropical vegetation and numerous river boats plying the stream at all times ideal scenes were secured.

The "Girl of the Golden West" Lasky Company, directed by Cecil de Mille, was at King's Camp, near Hemet, Cal., in the snow clad mountain district, last week making exteriors in the snow. When the players were ordered to report for the trip all were instructed to bring overcoats and winter clothing, and from reports by letter they are all sorry they did not take more. The change in temperature between the Lasky studio and King's Camp country at this season is seventy to ninety degrees.

President Samuel Long and Auditor C. F. Wilson, of the Kalem Company, of New York City, spent last week in Los Angeles, visiting at the three studios—Glendale, Hollywood and Santa Monica.

Harry Pollard, of the American at Santa Barbara, spent last week in Los Angeles, and Saturday was accompanied to the home of the Flying A by Joseph E. Singleton, Edward Alexander and William Carroll, who will play in the new multiple reel.

Eighth Kalem Serial Film Ready

Walter Newman, assistant general manager and producer of the U. S. Feature Film Company, Oroville, Cal., has spent the past three weeks in Los Angeles, supervising the developing, printing and cutting of the company's picture, "Folly of a Life of Crime," which portrays the life of the Sontag and Evans gang of desperados from the childhood of the men, through their lives of crime, years in prison, and final parole. George Sontag, the gang leader, plays the lead part in the picture, which will be released soon.

The eighth number of the Kalem, each-complete-in-itself series, "The Hazards of Helen," has been completed by J. P. McGowan at the Glendale studio. The producing title of this was "A Daring Deed," in which Helen Holmes seizes a small child and jumps with it from a railroad bridge just as a train thunders past. For this picture a special train was chartered.

One of the one-reel pictures recently made by Hobart Bosworth will be released in the near future under the title of "The Beach Combers," a feature of which is the rescue of Mr. Bosworth, playing the part of a sailor, by Duke Kahanamoku, the Hawaiian, who holds the world championship for short distance swimming.

The picture was made, and later it was found the champion might lose his right as an amateur if swimming for money. Rather than cause the young man such trouble, Mr. Bosworth held up the picture until a decision was rendered by the amateur athletic association officers.

J. A. Ramsey, camera man for the Faust Photoplay Company, has returned from a six weeks' trip in the Yellowstone Park country, where he made more than 4,000 feet of scenic, animal and ranch life pictures.

Newspaper Picture

Director De La Parelle, of the Masterpiece Film Company, in need of a scene of the shipping department of a newspaper office for the second production of the company, "The Truth Wagon," a newspaper picture, was forced to have the picture made from a window of a room occupied by the switchboard of a local telephone company, as from there the desirable view could be secured.

He lived through the ordeal of being besieged by more than a hundred "number" girls, but was forced to fill the back of all the pages of the script with names of applicants.

The Lasky studio accommodations have just been increased in order that an additional company—making a total of four—can work there at one time. Fifteen more dressing rooms have been added, the stage increased, a new scenery storage room erected, and numerous other improvements made.

And while the mechanics were busy getting the studio ready, scenarios, casts and property lists were prepared for four five-

reel pictures, and work was begun on three of these last week.

The productions now under way are "The Girl of the Golden West," from the David Belasco play of that name, featuring Mabel Van Buren, with a supporting cast, including House Peters as the Road Agent and Theodore Roberts as Sheriff Jack Rance, the part made famous on the legitimate stage by Frank Keenan. Cecil de Mille is directing the production of the photoplay.

Director Oscar Apfel is in charge of filming "Cameo Kirby," by Booth Tarkington and Harry Leon Wilson, in which Dustin Farnum will be featured with Winifred Kingston playing the feminine lead.

The fourth company began work the early part of last week, immediately fol-

lowing the arrival of Edith Taliaferro, from New York City, who will appear in "The Stowaway," adapted from the Tracy Louis novel. George Melford, for more than five years managing director at the Kalem studio, in Glendale, finished his work there the latter part of last week and will be connected with the Lasky company as director.

The visit of Mr. Lasky is a very pleasing event to the members of the producing company. He is personally acquainted with everyone, from leads to those playing the most obscure parts, stage carpenters, errand boys, and knows every cowboy by name. His reports from the East are always a feature of his visits, highly appreciated by the players, and his criticisms are sought by all.

Rosenbach Finds Prosperity in Middle West

Cheerful Tone Prevails in All Lines of Business, and Demand for Good Pictures Is on Increase, Says Excelsior Sales Manager

"WE in New York City are liable to believe that we thoroughly represent the conditions throughout the country, and this is usually the case," said Arthur M. Rosenbach, of the Excelsior Feature Film Company. "Just now, however, the European War seriously affects New York far more than it does other parts of the country.

"New York City with its enormous importing, stock and cotton brokerage, and allied interests, has seriously felt the check which the war has imposed upon these industries. Naturally, all business in New York City is affected to some degree by the serious curtailment in these lines.

"Outside of New York I have found conditions very different. The Ohio and Mississippi valleys are enormously prosperous, and even such cities as St. Louis, dependent to a large degree on Southern trade, are optimistic. In fact, throughout the entire section that I traveled over recently, I have never noticed a more cheerful tone and more actual evidence of business success than at the present time.

"Felix Feist, of the Celebrated Feature Film Company, Chicago, was decidedly enthusiastic about trade conditions. His idea coincides so exactly with my own that I take this opportunity of expressing them. His idea was that the more substantial and really reliable exchanges throughout the country were daily strengthening their positions by aligning themselves with the stronger manufacturers, such as the Excelsior Feature Film Company, a combination that could only work for the benefit of the industry at large.

"I fully realize that the wasteful method formerly used by manufacturers in placing their pictures before the public, if not already a thing of the past, is rapidly becoming so, and the older method of State Righting a picture with all of its inherent disadvantages must yield to the more modern methods of marketing. I cannot think of anything that would better tend to strengthen and solidify the motion picture industry than the present movement to concentrate the higher class picture in the hands of the stronger booking organizations.

"A few producers of inferior pictures are to-day loudly wailing over their inability

to find a market, but pictures of genuine quality are always in demand, and Mr. Goldberg, of the Casino Feature Film Company of Detroit, exactly expressed my ideas with the assertion that a strong story, good photography, and high grade acting must always have a recognized commercial value, and that each day increases the number of exhibitors, who appreciate quality even though it might mean a slight increase in the cost of their services.

"I have seldom had a more satisfactory trip in every way than the one which I have just completed. The farming districts through which I passed were all prepared for bumper crops, and the manufacturing sections were all busy to capacity. When a man has had a satisfactory trip, such as I have had, he is naturally optimistic, but I do not believe that my hopeful views are merely a reflection of the success of the Excelsior Feature Film Company. I am confident as the result of my observations that the market for high grade pictures, such as "The Path Forbidden" and "When Fate Leads Trump" is daily growing stronger, more dependable, and in every way more satisfactory."

"UNDER FALSE COLORS" FEATURES FLORENCE LA BADIE

"Under False Colors," a two-reel Than-houser feature in which Florence La Badie will be presented, is the first release of a series of strong dramatic pictures in which this famous young woman will appear. In these forthcoming two-reel features, her admirers will have an opportunity to see this remarkable girl at her best.

ARE YOU USING IT? THESE MEN ARE. SEE PAGE 51

"I think the idea is a good one, and there is no doubt the exhibitor would appreciate same."—BEN H. ZERR, Schuylerville Ave., Reading, Pa.

"It is a first-class idea, and it will save the small exhibitor a printer's bill, as a form like this comes high for him to get printed. It is invaluable."—B. C. WILSON, The Osborne Co., Ltd., Winnipeg, Canada.

CLAUDE PATIN SENDS NEWSY POST CARDS FROM PARIS

Claude Patin, secretary-general manager of the Eclair Company, who left New York last August for Paris to join the French colors, and is serving, with the rank of first lieutenant, as an aide de camp, attached to the staff of the Minister of War, has been heard from by his friends in New York City.

A number of picture post cards were sent by Mr. Patin to MOTION PICTURE NEWS office containing tabloid news items of interest to the trade.

Mr. Patin declares that the Eclair, Gaumont, Pathé and Eclipse companies are working with reduced forces, but have ceased all production for the present. Only a few motion picture theatres are open in France. Mr. Patin has been serving on a detail whose duties consist of watching German prisoners, but he expects to be sent to the front shortly, serving on the English general staff.

Mr. Patin has found time to keep track of the film industry in this country regardless of the demands made upon him by the duties of his position. He has received MOTION PICTURE NEWS with regularity and finds something of interest in every number.

The post cards mailed by Mr. Patin show scenes in and about Paris, a Creusot gun ready for firing and a troop of mountain artillery at manoeuvres.

GREAT NORTHERN HAS NEW SLEUTH PICTURE

The Great Northern Film Company's latest release is a three-reel feature, entitled "The Charlotte Street Mystery." As the names implies, it is a detective drama.

The story is replete with exciting episodes, dealing with the interesting adventures of an exceptionally clever woman, who seeks to elude the law, and succeeds in baffling a shrewd detective for some time, but is finally captured, after several thrilling escapes.

The role of the woman is in the hands of the capable Great Northern leading woman, Miss Elsie Frolich.

ORGAN AT ALLENDALE READY

On Monday, November 9, the management of the Allendale Theatre, Buffalo, N. Y., changed. J. J. Kelly, of Hornell, N. Y., and for the last few months road man for Joe Schuchert, who controls the State rights on "Neptune's Daughter," succeeded E. C. MacFadden.

The organ at the Allendale is about completed and a "try out" of the many applicants for organist will be held next Monday at the Elmwood Theatre.

HARRISH INGRAHAM WITH EACO FILM COMPANY

Harrish Ingraham is one of the latest players to enlist under the banner of the Edwin August Eaco Films Company. Mr. Ingraham before entering pictures held a number of good stock engagements throughout the west. Before joining Edwin August he was with Pathe for some time, and leading man and scenario editor for the Whitman Feature Film Company.

"Nightingale" Successful Wherever Shown

All-Star Alco Release Featuring Ethel Barrymore a Favorite as a Premiere Attraction for New Theatres—Return Engagements Sure

A LARGE number of new motion picture theatres over the country generally are using the Alco release Ethel Barrymore in "The Nightingale" as their initial attraction. The management and patrons of these theatres are making the occasions almost Broadway first nights. According to the local newspapers there are lines of automobiles outside of the theatres, and people seldom seen at motion picture gatherings are crowding the theatres.

Manager Guy C. Smith, of the Oakland Theatre, California, proved unusually enterprising. He remodeled his whole house in honor of Miss Barrymore in "The Nightingale." Decorators transformed the theatre into a spring garden with white lattice work upon which vines climbed were in the lobbies and along the stairways and walls. Throughout the house there was a harmonious Barrymore color scheme.

Manager Smith, who by the way has signed with the Alco Film Corporation for five years' service, was so pleased with the success of "The Nightingale" and with its receipts that he has decided to "dress" his theatre for each engagement of the Alco program.

Miss Barrymore in "The Nightingale" was used in Tacoma, Washington, to open the new Colonial Theatre. According to the Tacoma *Ledger* "thousands of admiring Tacomans kept all available seats filled, and there was a long sidewalk line until late in the evening." This theatre, by the way, cost \$110,000 to complete and equip.

"Shore Acres," "The Education of Mr. Pipp," Beatriz Michelena in "Salomy Jane," "Mrs. Wiggs of the Cabbage Patch" and "Little Lord Fauntleroy," follow Miss Barrymore in this new western theatre.

This use of "The Nightingale" is by no means confined to the west. Columbus, Ohio, has a new and unusually complete and attractive motion picture theatre in The Hippodrome. Miss Barrymore in "The Nightingale" opened this house. Manager Swan, of The Hippodrome, took natural pride in the fact that he had been able to secure the Alco program. Hence before the theatre opened he gave a series of private views of the picture to friends and prominent citizens of the Ohio city.

The same picture opened the new Strand Theatre of Washington, Pennsylvania. This theatre, too, had been remodeled. The local newspapers united in the opinion expressed by *The Washington Observer* that "The Nightingale" was "a stirring drama of heart interest, and one that drew big houses."

And where Miss Barrymore in "The Nightingale" had been they are welcome visitors for a return engagement. In Philadelphia "The Nightingale" broke all house records at the Regent Theatre. There was immediate strong competition among the Philadelphia picture houses for a return engagement. The Locust Theatre was successful, and Augustus Thomas' photoplay of love, hatred and music, which he himself staged, played to crowded houses.

Detroit League Getting Results for Exhibitors

Organization, Inspired with Desire to Do Things of Real Benefit, Watches Dangerous Censor Legislation with Effective Results

Special to MOTION PICTURE NEWS

Detroit, Nov. 17.

AT the last meeting of the Detroit Motion Picture Exhibitors League plans were discussed for arousing exhibitors throughout the state to the necessity for united action to prevent legislation this winter inimical to the motion picture industry. The watchfulness of the exhibitors League has forestalled some of the dangerous efforts of cranks, though it has not been able to entirely suppress them. They will make renewed efforts when the legislature convenes this winter to pass unwholesome censorship measures, unfair tax laws and other just bills.

All this President Peter Jeup set before the exhibitors, together with a recapitulation of some of the things the League has accomplished in checking the efforts of these hostile interests. It has prevented obnoxious censorship in Detroit, has kept state censorship out of Michigan so far, has fought every inch of ground in the matter of inspection fees, has done much to eliminate the film pirates who would give seven and eight reels for a nickel, and in more ways than one proven of benefit to the exhibitors of Detroit and of the state.

Benjamin Converse, an Owosso exhibitor, who was present at the meeting, voiced

the appreciation of the wide-awake state exhibitors of the work of the Detroit men and urged a canvass of the state to get every exhibitor into the Michigan organization. He promised himself to buttonhole every exhibitor in Shiwassee county with whom he could come in contact.

J. J. Fowser, formerly of Lansing, seconded the remarks of Mr. Converse, and told of conditions he had observed in Indiana, and particularly in Gary, where on certain nights pictures were being run to which persons only eighteen years of age or over were admitted, a condition which he said must not be allowed to enter Michigan.

Incidents showing the unfair manner in which inspection is made were related by various members, Mr. Fowser telling of one house in which the rheostat consisted of coils of wire around nails driven into a post in the cellar, an arrangement which would throw one the length of the cellar if he touched it. Yet this house passed inspection, while other houses were condemned for technical offenses against the inspection law, harmless in themselves.

George H. Wiley, former secretary of the Motion Picture Exhibitors League of America, arrived in town during the meeting and was escorted to the hall, where he met some of the exhibitors.

Motion Picture News

HAS THE QUALITY CIRCULATION OF THE TRADE

MOVING PICTURE NEWS EXHIBITORS' TIMES
Published Every Week by

EXHIBITORS' TIMES, Inc.

220 West 42nd Street, New York City.

TELEPHONE BRYANT 7650

Chicago Offices, 223 W. Jackson Boulevard
Los Angeles Offices, 427 S. Figueroa Street

WILLIAM A. JOHNSTON.....President
HENRY F. SEWALL.....Vice-President
E. KENDALL GILLET.....Secretary
H. ASHTON WYCKOFF.....Treasurer
WENTWORTH TUCKER.....Ass't Treasurer.

WILLIAM A. JOHNSTON.....Editor
LESLEY MASON.....Managing Editor
WILLIAM RESSMAN ANDREWS.....News Editor
H. ASHTON WYCKOFF.....Business Manager
R. M. VANDIVERT.....Advertising Manager
E. J. HUDSON.....Circulation Manager
THEODORE S. MEAD.....Chicago Manager
J. C. JESSEN.....Los Angeles Manager

This publication is owned and published by Exhibitors' Times, incorporated under the laws of the State of New York. The offices and principal place of business are at 220 West 42nd Street, New York City. The address of the officers is the office of the publication.

Entered as Second-Class matter at the New York Post-Office.

Subscription \$2.00 per year, postpaid in the United States, Mexico, Hawaii, Porto Rico and the Philippine Islands. Canada, \$3.00; Foreign \$4.00 per year.

ADVERTISING RATES ON APPLICATION.

Copy for next issue must reach us by Tuesday, 5 p. m.

Cuts and copy are received subject to the approval of the publishers and advertisements are inserted absolutely without condition expressed or implied as to what appears in the text portion of the paper.

Vol. X

November 28, 1914

No. 21

Real Quality Vs. Films That Are "Just as Good"

"YOUR editorials on the peril of poor pictures to this business have been hitting a few nails on the head," said a New York State exchange man the other day.

"But there's one nail that your hammer hasn't cracked yet. And it's sticking out just where a good many people are going to stub their toes over it before they're through.

* * *

"I'M not talking about the poor picture now.

"I mean the mediocre picture, the picture that just 'gets by,' the picture that isn't really bad, but about which there's nothing particularly good, the picture that irritates you and disappoints you because it's just good enough to make you feel that there's no excuse for its not being a great deal better.

* * *

"MAYBE you think this is too fine a distinction, or that there are no such pictures at all. To be more specific, then, I mean the picture that has nothing to save it from being a third-rater but the name of a famous stage star, or the title of a famous play or novel.

"This season has brought more of them to the front than any previous year that I can recollect. They have come out like earth-worms after a rain.

"And the worst feature of them—the one that injures the business in general most—is that they are not *extremely* poor from any standpoint. You can't honestly roast them—they're passable, but they're not one-tenth of one degree better than they have to be to 'get by.'

* * *

"READ the publicity that's put out on them, read the advertisements of them, note the name of the star and the name of the book or play from which they are taken, and you are justified in expecting a superlative production.

"You have every right to anticipate fine photography, sumptuous staging, splendid scenery as backgrounds, sterling acting, a production that exhales quality at every foot.

* * *

"INSTEAD of which, what do you get, in eight cases out of ten?

"Photography that is—just fair; acting that is—just fair; settings that are—just fair; a picture, in a word, that is—just fair. The entire production has a cheap, false—I was about to say, fake—tone all the way through.

"It's like playing a fine march on a 10-cent tin cornet. Did you ever hear a German street band try to play 'The Fifth Nocturne?' Well, such productions as this are in the same class.

* * *

"TELL the men who are making these pictures what I'm telling you, and they'll say, 'What are you kicking about? These films will satisfy the audiences that see them; that's all the exhibitor wants. They'll get by.'

"To which remark I'd simply like to retort that the men who believe that have either not been in the business long enough to know better, or they've been in it so long that they can't realize the change in the critical discrimination of motion picture audiences during the last year and a half.

* * *

"IF these were the best pictures being made, I would say that their speculation on 'putting one across' on the patrons of the theatres was a good sportsman's gamble. *But they're not, by a long walk.*

"In every town where these alleged 'quality features' are being shown, there is a theatre where *real quality features* are to be seen. The people have a chance to compare them—if they don't get wise sooner, they will later.

"What's the answer for the exhibitor? You know, and so do I. The theatre that runs *real quality pictures* will get the crowds in the long run.

"The other exhibitor will go down, clawing the air, and execrating the producers that sent him such 'mercerized,' 'just-as-good-as' stuff to meet the other fellow's competition with.

"Worse than that, these imitations will ultimately cause a reaction against *all* features, and the producer of good pictures will suffer with the producers of poor ones.

"Why don't you put the exhibitor and the rest of the business on guard against such productions?"

And we have.

* * *

Business Revival

THE general revival of business conditions expected for months is now here. The New York *Tribune* showed by a thorough canvass made throughout the country only a few days ago a justification of the hopeful view maintained by keen observers of the nation's prosperity.

Business has unquestionably taken an upward trend, and with the widespread resumption of commercial progress in the United States motion pictures have received their meed of benefit. Recent reports from film manufacturers indicate a return of confidence.

The Exhibitors' Forum

MOTION PICTURE NEWS assumes no responsibility for any opinion or assertion made in the columns below, nor does the publication of a letter mean that the statements it contains are endorsed by the NEWS. All letters must be signed. No attention will be paid to anonymous communications

Herrington Calls for United Action in Pennsylvania

Editor, MOTION PICTURE NEWS,
New York City.

Dear Sir: Let our slogan be on to Harrisburg, to attend the convention of the Motion Picture Exhibitors, January 4, 5 and 6, 1915. Let us use the power that invention and science has placed in our hands and get into a higher state as business men, and lay aside your little personal bickerings and quit fighting your imaginary foe and get together in one organization and face the common enemy, the politician and the so-called reformer. It makes no difference if you have a house that seats one hundred or two thousand, your interests are the same, so let's get into one big organization before it's too late, or before they censor or tax us out of business.

Let us look at this question of taxation and see where it started. First we had the mercantile tax, then the city, town or borough tax, then the state tax. Now comes the war tax, and we are asking each other where will it stop. We do not know what will be the next form of tax. It may be an emergency or some other form of tax, we cannot tell. We do not say that we should not pay any tax, but we are not satisfied to pay all the taxes.

All kinds of freak legislation is threatened and used on us. For example, let us name a few of them. There is the censorship of the film, censorship of posters, regulation of admission of children, the segregation of the sexes, and many others. Now the time has come for us to do something, so let the exhibitors get into action at the convention at Harrisburg.

Now let us know that you are with us, and let our motto be one for all and all for one. And don't forget to boost the convention.

For information write to the Motion Picture Exhibitors' Association, No. 113 Fourth avenue, Pittsburgh, Pa.

Fred J. Herrington, Organizer.

Jep Makes Strong Appeal for Membership

Jeter J. Jep, president of State Branch No. 4, of the Motion Picture Exhibitors' League of America, has issued a strong appeal to exhibitors for their support. He has sent out the following letter:

MR. EXHIBITOR,

DEAR SIR: Once more I appeal to you to join the Motion Picture Exhibitors' League,

giving you a few reasons. The legislature is about to convene at Lansing, and some of the laws already mentioned to be introduced are: Closing theatres on Sunday, State license fee of \$100, prohibiting children from attending under sixteen years, unless accompanied by their parents, State and local censors, and etc., all of which we must prevent if possible, and can, if we have a strong organization.

Here are some of the things the league has accomplished: The National League has had the war tax reduced from a flat tax of \$100 to \$25 and \$50 which had passed Congress, but changed in the Senate through the efforts of Marion S. Pearce, national president M. P. E. L. of America. The State League prevented all of the above mentioned laws from being enacted two years ago; brought about the agreement making three reels the limit for a five-cent show and five reels for a ten-cent show; abolished the censor in Detroit; prevented unfavorable ordinances in reference to licensed operators; and recognition of the league by the film exchanges. We intend to fight to have the state inspection fee of \$20 or more repealed or reduced. The admission fee to this league is \$5 and dues fifty cents per month.

Now if there is any valid or good reason why you should not join and give us your moral and a little financial support I would like to know it, as I consider this as much a part of your business as your film supply, for it means your very existence.

The semi-annual meeting of the league will be held in room 255-259 Equity Building, Detroit, Tuesday, December 8, at 10 o'clock a. m. and I would be pleased to see you here at that time.

Fraternally yours,

PETER J. JEP,

President M. P. E. L. of America, State Branch No. 4.

Kohl Not Interested in Trade Paper

MOTION PICTURE EXHIBITORS' LEAGUE,
CLEVELAND LOCAL NO. 1.

Cleveland, O., Nov. 7.

Editor, MOTION PICTURE NEWS,

Dear Sir: I have been instructed to advise you that Mr. Kohl, of Cleveland, national vice-president of Ohio M. P. E. L. of A., has informed us that he is not interested in the trade journal about to be published per our communication to you on October 21.

Yours very truly,

W. H. HORSEY,

Secretary M. P. E. L. of A.,
Cleveland Local No. 1.

Aronowitz States Firm's Aim

Samuel E. Aronowitz, representing the Exhibitors All Feature Film Company, Inc., Albany, N. Y., issues a statement denying the announcement of the Cosmos company appearing under the heading, "Denies Rights to Cosmos Films."

Mr. Aronowitz says that in a prospectus published for the purpose of stating the aim of his company, certain parts of the document are responsible for the misunderstanding of the Cosmos company's position.

He makes the following statement:

"On page four of this prospectus there is the following sentence: 'Among the features already signed and under consideration are the following.' Then follows a list of films most of which has already been signed when this prospectus went to print, and the others of which were actually *under consideration*. Among those under consideration were 'The Key to Yesterday' and 'Lena Rivers.' The only reason the company did not take these pictures was that an agreement could not be reached as to all the details. Neither the officers nor any of the agents of this company ever claimed that the company had signed the two plays referred to, nor has this company ever sent out statements to the exhibitors already booked that they could have those plays."

Mr. Aronowitz also makes a statement concerning the offer of features at \$15 per day, by his company, as follows: "The company has agreed to (and will continue to) furnish those, owning at least ten shares of the stock of the company, features for a period of one year (at least one feature per week) for the price of \$15 for each feature."

"THE THIEF" COMPLETED FOR BOX OFFICE

Edgar Lewis as director for the Box Office Attraction Company has completed his screen production of "The Thief," which is in five parts. Mr. Lewis is now preparing to present a film version of "Samson," another well known drama by Henri Bernstein, author of "The Thief."

ARE YOU USING IT? THESE MEN ARE. SEE PAGE 51

"Very good."—JOHN GUTHINE,
The Majestic Theatre, Grove City, Pa.

"We think the plan fine."—THOS.
FURNISS, Rex Lyric Theatre, Duluth,
Minn.

"THE ROSE OF THE RANCHO"

(Lasky—Five Reels)

REVIEWED BY WILLIAM A. JOHNSTON

THERE can be no division of opinion about the Lasky-Belasco production of "The Rose of the Rancho." It is not only a distinct triumph in itself, but also it marks as does no other production the triumph of the picture drama.

If the best stage plays can be picturized with such success that the picture even excels the play—and now we know that this is possible—then the horizon of the photo-play is practically illimitable.

The first exhibition of this remarkable picture was given on Sunday evening, November 15, to an audience that filled the Belasco theatre and sat spell-bound from the introduction of the characters to the last beautiful scene in the Padre's garden.

It is a fact that never for an instant did the action lag. Heart-interest and atmosphere were always and admirably sustained. The acting was as excellent as that of the well balanced casts of our best stage productions.

David Belasco voiced the feelings of probably every one of the audience when, so it is reported, he said: "This is better than the play."

Great credit is due to everyone concerned in the production, from beginning to end. Richard Walton Tully, co-author with David Belasco of the original play, assisted Cecil De Mille and Wilfred Buckland in the direction. These gentlemen have scored a remarkable success.

Bessie Barriscale as Juanita made her first screen appearance and achieved for herself at the same time a fine reputation in filmdom. Her support by the Lasky Stock Company was excellent throughout—J. W. Johnston as Kearney, Jane Darwell as Senora Castro, James Neill as the Padre, Monroe Salisbury are especially deserving of mention but not without a measure of praise to every single member of the cast.

The cast follow:

Juanita, daughter of Castro family, Bessie Barriscale; Senora Castro Kenton, her mother, Jane Darwell; Esra Kincaid, "Land Jumper," Dick La Reno; Kearney of U. S. Government, J. W. Johnston; Don Luis del Torre, in love with Juanita, Monroe Salisbury; Padre Antonio, of the Mission, James Neill; Espinoza, Ranch Owner, Sydney Deane; Half Breed, Billy Elmer, and Isabelita, Espinoza's daughter, Jeanie McPherson.

The story is set in 1850, when the government at Washington



KEARNEY IS CAPTURED BY THE MILITIA

decreed that all ranch owners must register their properties, and the Spanish rancheros of California, already seemingly humiliated by coming under the rule of the hated "gringos," refused to comply and a system of land jumpers roamed about.

The government learning of the land jumping, and that the 'licit trade was growing, sent Kearney, a secret agent, to California to investigate.

Kincaid, a worthless and conscienceless scoundrel, learns from one of his men that Senor Espinoza, a rich Spanish ranchero, has vowed that he will never register his land, and seizing the opportunity, Kincaid and his men ride down on the Espinoza family when they are at dinner.

Ignoring protests and refusing cash, Kincaid takes possession of the ranch and Isabelita, the eldest daughter, is captured by a half breed, who while fighting for possession of the girl, mortally wounds Espinoza, and Isabelita knowing her fate at the hands of the Indian, kills herself.

The picture will be shown at the Strand, New York City, Sunday, November 29.

"ARISTOCRACY"

(Famous Players-Paramount—Four Reels)

REVIEWED BY PETER MILNE

SOCIETY dramas are not an uncommon variety of pictures. They can be seen any day at any place. They are palmed off on the unsuspecting as true portrayals of modern life in the higher circles of society. Very often they are so untrue that the affect the production borders on the ridiculous, yet they keep on coming. If they didn't, the producers would be at a considerable drawback to find something to produce in their stead.



INTERRUPTED IN HIS VENGEANCE

We won't go as far as to say that "aristocracy" is altogether true to life, but if real persons were placed in the same positions which confront the characters of this story, their actions would, in all probability, be very much like, if not exactly the same as those of the main persons of this picture. Their parts are sincere, none of them are forced and a cast of capable players performs in the leading roles, most obviously well trained in motion-picture technique.

Tyrone Power is the latest legitimate actor added to the long list of Famous Players stars borrowed from the stage for a short time. His rendition of the part of Mr. Stockton, a self-made man of America is sincere, powerful and dramatic. Diana, his wife, is played by Marguerite Skirvin in a manner that leaves no room for improvement. Edna Mayo is sweet, pretty and pathetic as Virginia, the daughter of Stockton and the step-daughter of Diana. Arthur Hoops appears in his familiar role of heavy. He is a penniless foreign prince, utterly without honor, but possessing a magnetic attraction which he exercises over the unfortunate woman whom he happens to desire.

The picture is strong, powerful and gripping every moment of its length. From the time that the happy romance of Virginia and Stuyvesant is broken off, because of the objection of the latter's parents, until they are finally united again, after Virginia and her step-mother have gone through the terrible ordeal of becoming mixed up in the so-called aristocracy of Europe, the story holds one almost entranced.

Scenes which take place in the chamber of Diana, between her and the prince are rendered powerful, whereas they might appear repelling by sharp cuts or quick fadeouts. Just as a matter of form it might be mentioned that all the scenes of the picture are undeniably realistic, and the photography is as good as ever.

A little difficulty may be found in straightening out the characters in the first part of the play, accountable to their somewhat abbreviated introduction, but it is not long before we are thoroughly acquainted with all of them, and it is safe to say that none of us will be sorry for the acquaintance.

"THE MASTER KEY"

(Universal Special—First Episode)

REVIEWED BY PETER MILNE

AFTER the extensive amount of advertising that the Universal Company has given "The Master Key" it seems hardly necessary to announce the fact that it is their new serial. It and all the other following chapters are in two reels and are to be released at intervals of one week, beginning with the week of November 16.

It seems to be the policy of the Universal Company to secure the services of the best writers of the time for all their recurrent stories, and some of the others also. Louis Joseph Vance is responsible for "The Trey o' Hearts" and the "Terence O'Rourke" stories; George Bronson Howard was the creator of the "Francois Villon" pictures, and now we are introduced to the handiwork of John Fleming Wilson, the author of "The Master Key" and numerous other stories and novels.



AN APPARITION APPEARS TO GALLON

Robert Leonard and Calder Johnstone scenarioized the story, and the former is also director and leading man. The other players are the not unfamiliar ones. They have long played under the direction of Mr. Leonard in Rex pictures. Ella Hall, one of the youngest actresses on the screen who interprets grown up parts, will appear throughout the series as the daughter of John Gallon, a mine owner. The part of Gallon, is played by Wilbur Higby. Wilkerson, Gallon's former partner, is impersonated by Harry Carter, who bids fair to develop into the leading villain of the story. Robert Leonard appears as John Dore, a young mining engineer.

The story opens with the spectacle of Gallon and Wilkerson searching for gold. Gallon finds a streak of the ore, and when making notes of it in his book refuses to tell his partner of the facts. His aloofness leads to a fight between the two men, in which Wilkerson is worsted. Gallon flees, believing he has killed him. He learns later that he is still alive, and of course, is in deadly fear of his return.

He opens his mine at the spot of their quarrel, which by virtue of keeping his secret concerning Wilkerson in an iron box locked with a key he calls the "Master Key Mine." Not being able to locate the gold, he sends for the services of a mining engineer and Dore puts in his appearance.

Realism predominates in the scenes about the mine, the cottages of the miners, the house of their employer—the shuttle trains, the bridges, and the heaps of blasted rock are all shown in panoramic views. One thrilling event occurs in this episode, the burning and sinking of a ship on which is Gallon. His plans go to the bottom with the sloop, and for this reason he is unable to locate the gold. The photography and scenes are excellent, and the tinting every bit as good.

At the start "The Master Key" looks like a winner, and bids fair to uphold the high mark set by the two other Universal big serials.

"THE BLOOD-RED ROSE"

(Selig—Three Reel)

REVIEWED BY T. S. MEAD

A CHARMINGLY beautiful fantasy is the story of the origin of the first blood red rose, written by James Oliver Curwood; and not one whit of the charm has been lost by its production upon the screen. In fact, after seeing all the magic of an enchanting fairy tale take place so realistically before your eyes, it is mighty hard to come down to cold earth and give up your recently acquired belief in fairies or rather witches, for it is a witch in this case, though a perfectly nice one.

Kathlyn Williams as Godiva does a lot to make this not merely a fairy tale, but a real drama, and a tragic one at that, of a fanciful kingdom in mediæval times. Supporting her with equally clever acting is Wheeler Oakman in the role of Paulo, her huntsman lover. Charles Clary, Eugenie Besserer, Frank Clark and Camille Astor are also included in the well selected cast.

The exteriors and interiors are well selected and in perfect keeping with the story, while the unusual scenic effects are excellently executed.

Paulo, the handsome young huntsman in the forest of the King of Urania, and his beautiful sweetheart Godiva are friends of the witch Hagar, who, to repay them for a kindness, gives Godiva a magic potion which will change her into a white rose. The two lovers are very happy until one day the King of Urania sees Godiva and, struck by her beauty, forces his attention upon her.

At the sight of this, Paulo in a burst of jealousy seizes the monarch by the throat, and as a result is put into a dungeon underneath the palace. The King, still enamored of the fair Godiva, kidnaps her and places her in a secret chamber of the castle.

The incident comes to the ears of the queen, and she plans to murder her dangerously beautiful rival. The king, angered by Godiva's repulses of his wooing, leads her down to the dungeon where Paulo is held captive, in order that he may exult in the misery the sight of her lover will cause.

While the king's attention is distracted for a moment, Godiva swallows the magic potion and at once is transformed into a white rose, which falls to the waiting hands of Paulo. Confusion follows and Paulo makes his escape. For a year he wanders about the forest, the fragrant white rose as his only companion.



PAULO MEETS GODIVA AFTER THE HUNT

One day he meets the king, and kills him, but in the fight that follows an arrow is sent through his breast, covering the rose with his life blood and staining it a deep red. This releases the soul of Godiva from the rose, and their two spirits are forever united.

BARCELONA FIRM WANTS AGENCY FOR FILMS

WE are in receipt of a communication from the firm of Masjuan-Cuadrada, Barcelona, Spain, in which they state that they are desirous of obtaining the agency rights of films manufactured in this country, for Spain and Portugal. Film companies please address Masjuan-Cuadrada, representantes de películas por España y Portugal Barcelona, Aviñó 18.

STIRRING MOMENTS IN THE LATEST ALLIANCE-FAVORITE RELEASE, "THE MAN WHO COULD NOT LOSE"



WATCHING DROMEDARY WIN

THE INSULT

"THE MAN WHO COULD NOT LOSE"

"THE TOREADOR'S OATH"

(Pathé—Three Reels)

REVIEWED BY CLIFFORD H. PANGBURN

THIS is a film which would convince the most cynical adherent of the legitimate stage that the production of motion pictures is an art. It presents a powerful, dramatic story in a series of beautiful scenes and by means of the finest sort of photography. "The Toreador's Oath" was made at Seville, Spain, with the happy result that the settings are at once realistic and attractive. It is a fine example of the results that can be attained by an almost complete avoidance of studio scenes.

Instead of the cold work of the stage carpenter, the greater part of the scenes in this film have as their backgrounds the streets, squares and terraces of Seville, the patios of Spanish houses, the bull ring, and the open country.

The beautiful effects thus obtained are further heightened by the fine toning of the whole film. It is typical of the production that the most unimportant of the scenes are as well done as the principal ones.

The cast is another fine feature. It is headed by Asta Nielson, who is seen as the toreador's wife. This actress is a Dane, but she is a distinct Spanish type, and makes an alluring and charming Castillian. She handles her difficult part with great skill. The supporting players are well suited to their roles, and are effective.

Juanita, a poor girl who sells cakes in the streets, is noticed by two famous toreadors, Gayetano and Manuel. The former's affection is real, while the latter's is merely lustful. Juanita soon marries Gayetano. They swear on the crucifix to love each other until death. Manuel, with the aid of a poor half-wit who adores Juanita, kidnaps her while her husband is at a bull fight in a nearby town.

The girl escapes, but finds that Manuel has poisoned her husband's mind so that he turns her out of the house. She vows vengeance. At a bull fight she distracts Manuel's attention just as a bull is about to charge, with the result that he is killed. Gayetano gets a divorce and marries Manuel's daughter. At the wedding Juanita appears and fascinates the bridegroom until he follows her to the spot where they had vowed life-long love. There Gayetano realizes too late his folly, and the pair die together.

"THE MAN WHO COULD NOT LOSE"

(Favorite Players-Alliance—Five Reels)

REVIEWED BY PETER MILNE

IF a picture is an adaptation from a well-known play of, as in this instance, a novel, it is practically sure of attracting a reasonable amount of attention. Whether it develops into a success or a failure depends upon the competency of the adapter and the suitability of the work for the screen, but all motion pictures which have appeared before in another form call for more notice than those which are entirely new in the form of pictures.

Sometimes they are worthy of this attention, and sometimes they are not. Concerning this particular production, it is deserving of all the favorable criticism it will receive.

Excellently qualified workers have been behind the story, from its career as a novel until its entrance into the field of screen productions. Richard Harding Davis is the author of the book, and in its adaptation none of the charm of the story has been lost.

It has also been carefully directed by Carlyle Blackwell, who plays the leading role as well. Again, the picture attains a degree of photographic perfection that embraces the highest efforts of a far seeing director and cameraman.

Some exceptionally gorgeous scenes have been filmed, and the same may be said of the sets which demand that property. Those which do not call for elaborate magnificence are fitting and realistic.

Carlyle Blackwell carries the part of a young writer who, in compliance with an editor's wishes, rushes his story through for the next issue of the magazine. We see the story he labors at into the far hours of the night. The leading figure is Carlyle Blackwell again, and again as a novelist, Champneys Carter, who is in love with the daughter of a man bent on marrying her to a bankrupt count.

Naturally, Carter marries her, and then proceeds to play the races, winning every time, finally showing up the count, breaking the bookmaker who ruined his father, and bringing the girl's parent around to the point where he is thankful he has such a lucky son-in-law.

The picture is a comedy-drama, of which class we have been honored with many of late. But however many, they are never tiresome, and are more restful and enjoyable than any other variety. Carter's quick, good natured and sharp personality as portrayed by Mr. Blackwell is ever so well done. The way he scatters one dollar bills around with alarming nonchalance, in fact his whole manner stamps him as the personification of a typical hero of a lively American novel.

Ruth Hartman is Dolly, the heroine, and a charming one she makes. Gipsie Abbott is her sister, who marries the Reverend Orlando Stone, a character played by James J. Sheehan, who has many chances to create laughter, and he fully utilizes them.

William Brunton plays the count, Thomas Delmar is the race track gambler, Harry Kernan the father of the two girls, and Hal Clements is the father of Carter.

The race track scenes, taken on a real course, are realistic. A few scenes of the horses starting, rounding a turn and finishing are employed more than once, but aside from this not a great deal in the picture is to be unfavorably criticised.

KALAMAZOO VOTES FOR SUNDAY SHOWS

Special to MOTION PICTURE NEWS

Detroit, Nov. 18.

ON Tuesday, November 3, Kalamazoo, Mich., voted in favor of Sunday shows, winning by a majority of 150 votes. At first it was announced that the proposed amendment to the city ordinance was lost, but on second count, it was found that a mistake had been made, votes had been placed in the wrong box and that instead of losing the amendment carried.

The amendment has received the stamp of approval from the members of the city council and the mayor, and the first Sunday entertainment in the Celery City will take place November 22.

"THE LAST EGYPTIAN" SHOWN TO 1,000 AT PRIVATE EXHIBITION IN LOS ANGELES

THE premier showing of the Oz company's recent production, "The Last Egyptian," from the novel of the same name by L. Frank Baum, president of the company, was made Monday evening, November 2, in the presence of a thousand people in the gymnasium of the Los Angeles Athletic Association.

Like all previous productions of this company, the picture abounds in beautiful settings, both natural and artificial, and to judge from the hundreds of beautiful scenes, the producer must have spent a good-sized fortune in the making of this picture.

As the title indicates, it is a picture of Egyptian life, with visits to the unexplored crypts of the dead kings, queens, princes and princesses of the now decayed dynasties, into which is woven the characteristic trait of the Oriental for revenge. World travelers who have visited Egypt and who saw the first projection of the picture, marvel at the ingenuity of the producer in preparing exact duplications of Nile river scenes.

The cast is headed by J. Farrell MacDonald, supported by Charles Hayden, Jane Urban, Mae Wells, Vivian Reed and other well known photoplayers.

"THE BRAND OF HIS TRIBE"

(101 Bison-Universal—Two Reels)

REVIEWED BY PETER MILNE

FILMS are very often artistically tinted and shaded to give the appearance that a scene takes place in the dead of night. Excellent imitations are the result of such processes, but it is always obvious that the scenes were really taken in daylight. In this picture, the director, Henry McRae, has introduced a series of scenes which cannot help bring forth the greatest praise and admiration.

Part of the film was actually exposed in the night time. This is the first time that we have seen such an innovation in American films. It has been attempted before, but with no great amount of success. Here it is a success, and the effect that it will produce will go a long way toward the success of the picture.

The event that is transpiring in these few scenes is a desperate battle waged between troops and Indians. They are at quite a distance from the camera, and engage in battle about the campfires of the redskins. The figures of the combatants are silhouetted against the glowing fires behind them and the resulting effect is most beautiful and effective.

Of course, one may not distinguish between the figures to such an extent that their identity may be determined, and in this respect the tinting and shading process has the advantage, but



THE DEATH OF WILCOX

the fact remains, that is plainly obvious, that the film was exposed at night.

Besides this praiseworthy technicality of the film it may be said that taken as a whole the picture is a regular riproaring Western, full of action of the most daring sort. Fast riding, falling, snatching people from the saddle while at full speed and the soldiers defending the stockade from the warring Indians are only a few of the many thrilling events that unite to make the picture one of the most thrilling of its kind.

The story is somewhat complicated, although it has been made

easy to follow by the concise interpretations rendered by the leading players. Val Pal plays Lieutenant Wilcox, who is captured by the Indians and forced to marry a squaw from their ranks. William Clifford is his son, who finally surmounts Captain Duncan's opposition to his marrying his daughter. Sherman Bainbridge is the Indian chief. Marie Walcamp is the white girl, and Rex de Roselli her father.

"LOLA"

(World Film—Five Reels)

REVIEWED BY PETER MILNE

WHEN Owen Davis created the name part of this production, "Lola," he did not, of course, have in mind that Clara Kimball Young was to interpret it on the screen. But if he had been thinking of this star and had modelled the part after her especial qualifications it is doubtful if it would have been more suited to her. Again, if the part had been allotted to a less accomplished artiste than Clara Kimball Young it is more than likely that it would have appeared obtrusive and loathsome. Due to her characterization of the role of "Lola," the obtrusiveness turns into pity for the



FLUWAY MAKES VIOLENT LOVE TO LOLA.

character, and the loathsomeness into admiration for the player.

Regretably, the story is not over pleasant. It is the dominating personality of the star, the excellent manner in which she plays her part with all the sympathy and feeling which have gone to make her famous which is accountable for the success of the picture.

It is well that none of them have important roles except these three. Alec B. Francis plays the father of Lola with all his accustomed feeling and ability. James Young, who is the director and adaptor as well as the leading male character, has the part of Dick Fenway, a dissolute young man, unscrupulous, rich and possessed of a very weak personality.

Tragic though the story is, it is so unconventional that it is pleasant to see. The termination is hardly obvious until the last scene. The situations are excellently developed by players and director, the scenes are appropriate and the photography is of the best.

Lola is the daughter of a doctor who has struggled all his life to perfect an electrical contrivance for restoring life to a body that has been dead only a short time. The girl is happy in aiding the poor; kind, lovable and sweet.

One day she is knocked down by an automobile and brought home, dead. Her father puts his invention to good use and brings her back to life. But instead of being the same sweet girl that she was before, she is irritable, tempestuous, even dishonest. Her good soul has left her, and instead she is the possessor of an exceptionally evil one.

She runs away with Fenway, a man she had before loathed. She becomes tired of him, flirts with a number of others and then finally lives with a man much older than herself.

Her doctor tells her that her heart is weak and that a sudden shock may bring death. She returns to her father to exact his promise to bring her back to life if she dies. They argue, she dies. And the miserable father in a rage destroys the machine.

"THE PERILS OF PAULINE"

(Eclectic—Eighteenth Episode)

REVIEWED BY PETER MILNE

"CAST as usual," reads the synopsis as distributed by the Eclectic Company. The statement is perfectly correct as far as it goes. Pearl White, Crane Wilbur and Paul Panzer are still greatly in evidence, but two new and not at all unknown persons are introduced in this chapter, namely Eleanor Woodruff and Jack Standing. They play important parts; in fact, this episode is woven about the characters which they impersonate, the other players for the time, being less in evidence.



THE CONSPIRATORS ARE THWARTED

Miss Woodruff plays the part of an international spy bent on securing the plans of a new submarine invented by Ensign Summers of the U. S. Navy. She joins forces with Owen, and the two plan that the submarine shall be disabled while at the bottom of the sea, so that the villainous secretary of this story may be successful in his attempt to do away with Pauline, and that Mlle. de Longeon may render the new invention useless to Americans while she may sell the plans to another nation at her own figure.

Their plot, fiendish as it is, comes near working out in a manner altogether favorable with the machinations of the conspirators, but the gallant Ensign, conceives the brilliant plan of shooting Pauline out through the aperture through which torpedoes are projected in times of war. She reaches the surface where Harry is anxiously awaiting the reappearance of the submarine. They reach the shore, inform the wrecking crew of the submarine's predicament, and it is speedily raised. The spy is found out, and the Ensign's happy love affair is rudely terminated.

This peril of Perilous Pauline is truly exciting, yet it may hardly be ranked with the best of her adventures, for the simple reason that it is not real. Although the submarine lying at the bottom of the sea is a very-cleverly executed piece of work, it is obvious that the situation is not real. Aside from this the other scenes are as realistic as ever. The submarine employed in the picture while on the surface of the water is very much the real thing. And the interior views of it are admirable imitations.

Pauline comes out triumphant as usual, yet even now she shows no outward signs of suspecting Owen as her worst enemy. We will, no doubt soon learn the fate of all the people concerned in the story as, it is said, "The Perils" only have two more episodes to run.

"THE TEST OF MANHOOD"

(Balboa—Box Office—Three Reels)

REVIEWED BY CLIFFORD H. PANGBURN

A FIGHT between the captain of a sailing vessel and some of the members of his crew furnishes some excitement of a rather unusual sort in this film, and also gives an opportunity for some effective photographic work. Other stirring scenes and an interesting story combine to make the film one that should please picture audiences.

The scenes present a wide range of attractive backgrounds, including sea and farm views of interest and beauty. In the course of the fight on the ship one of the men, whose part is played by

Bruce Randall, jumps into the sea from the yard arm after some daring climbing about the rigging.

The story tells of the son of a well-to-do farmer who is sent from home because of his reckless ways. He signs on as a sailor, and becomes more manly as a result of his hard work. He finally rebels against the brutality of the captain, and with two other sailors escapes and swims to shore.

He reaches home in time to spoil the plans of a lawyer who was about to obtain his father's farm by fraud. A reformed gambler had been the crook's unwilling partner. The farmer's son and his friends save her from the villain's hands, and she becomes the young man's bride. There are a number of good comedy touches.

The cast is headed by Dorothy Davenport and Henry King, who do good work. Others are Daniel Gilfeather, Archie Gibson, Bruce Randall, Charles Dudley and Fred Whitman.

MRS. WILCOX PREPARING PLAY FOR WARNER

ELLA WHEELER WILCOX will make her debut as a contributor to the literature of the screen by the release, shortly, of a five-reel play based on her famous poem, "The Price He Paid."

This film will be released by the United Film Service (Warner's Features, Inc.) through its 42 branches, and consequently will receive a simultaneous premiere in all the important centers of population throughout America.

The adaptation of "The Price He Paid" for film purposes was made by Louis Reeves Harrison in collaboration with Mrs. Wilcox. The work interested the author of "The Price He Paid" intensely—in fact, so much so that she has taken up the study of the construction of photoplays and will shortly turn to the task of independently converting many of her poems into photoplays.

It is likely that the estate of Mrs. Wilcox at Short Beach, Granite Bay, Connecticut, will figure as a background for the scenes of many of her future film productions. It is one of the most picturesque country places in America and abounds in unusual opportunities for the film photographer.



ELLA WHEELER WILCOX AND GERTRUDE SHIPMAN OF THE HUMANOLGY COMPANY

A bay, a rock-bound coast, woods and fields, a rustic bungalow and gardens are physical aspects of a spot peculiarly blessed with natural advantages.

Realization of this fact has caused Mrs. Wilcox to consider the erection of a studio, this to serve as an adjunct to the plant of the Humanology Film Producing Company, of Medford, Mass., which is manufacturing the adaptations of the Wilcox poems.

Lawrence McGill is the director of the Humanology company, which has only just been organized, with a capitalization of \$250,000 and a directorate comprised of foremost Boston business men.

BOX OFFICE APPOINTS BRANCH MANAGERS

C. L. WORTHINGTON, well known in film circles in Pennsylvania, has been appointed manager of The Box Office Attraction Company's branch located at 1333 Vine street, Philadelphia.

F. W. Mead, has been appointed manager of The Box Office Attraction Company's branch in Boston.

"HIS HEART, HIS HAND, HIS SWORD"

(Victor-Universal—Two Reels)

REVIEWED BY PETER MILNE

THOSE Universal fans who have been longing for a continued story in which their screen friend, J. Warren Kerrigan, should appear are now to be satisfied. "His Heart, His Hand, His Sword," is the first picture of the "Terrence O'Rourke" stories which are being produced for Universal by Jacques Jacard and his Victor company which Kerrigan heads. The pictures of which there are to be over a dozen are adapted from the series of stories written by Louis Joseph Vance, which ran in the "Popular Magazine."

Mr. Vance has already proved his ability to write stories in which the action is of the swiftest and most thrilling variety. If anyone doubts this he can go and see any chapter of "The Trey o' Hearts," and his doubts will be speedily removed. The first

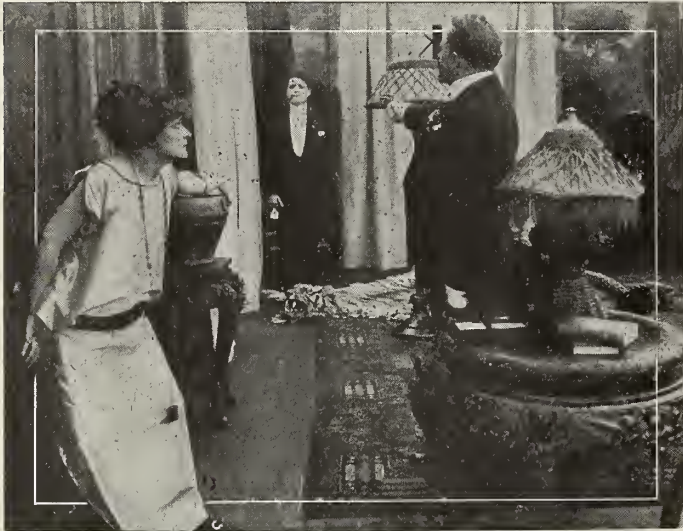

THE PRINCESS INTERRUPTS THE DUEL

of the Terrence O'Rourke series gives promise of great things to follow, although the introduction of the characters leaves small room for any great formation of plot. However, there is enough action in it to afford ample entertainment.

Supporting Kerrigan is the usual cast with which he appears. Vera Sisson needs no introduction to patrons of the Universal program. She plays her part in her usual way; it is not clearly defined just yet who she really is, but we gather that she is married and unhappily at that, so one may expect great things soon, with a dashing young adventurer like Kerrigan flying around. M. B. Robbins is the husband, greedy and selfish, with never a thought for his wife. At the end of this story his mind is preoccupied by devising some scheme by which he can do away with friend Terrence. George Periolot also appears.

Princess Beatrice is the role which Miss Sisson carries, and she being told who this wonderful adventurer is, sends him on a mission of great importance to help her brother, who is establishing an empire in the Soudan desert. It is a thrilling mission, and something well suited to our hero's daring and reckless character.

"THE ADOPTED DAUGHTER"

(Warners—Three Reels)

REVIEWED BY PETER MILNE

THE reappearance of Ethel Grandin on the screen will not pass unnoticed by the large following the dainty little star obtained when with another company. That she is now appearing under the banner of Warner's Features is a credit to them. Miss Grandin, the most recent acquisition of this company, will go a long way to further establish its popularity.

As to the picture itself, it is a fitting vehicle for the engaging personality of its leading player. A dual role has been allotted Miss Grandin, that of the adopted daughter of a police captain, who has been taken care of as if she were the man's real daughter, believing all the time that she is.

On the other hand, she is a girl of the underworld, differing

entirely in character and breeding from her double, who turns out later to be her twin sister. Very naturally the two parts offer a wide field over which Miss Grandin is called upon to exercise a considerable amount of dramatic ability.

She has so succeeded that the two parts are never confused, although there has been an unusual number of opportunities for so doing.

The situations into which the resemblance of the two girls draw the principal characters into are intricate and very cleverly conceived by the writer of the scenario. When Ethel, presumably the daughter of the police captain, is seen by her lover attempting to fathom the reason of the latter's coldness, by delving into the realms of the underworld, he very naturally is confirmed in his previous unfounded suspicions concerning the life she leads.

Likewise when Pearl, the child of the streets, is seen in conference with various members of the police force, the suspicions of her male companion are justly aroused. Each of the two girls are mistaken for the other time and again, but finally with the death of Pearl matters are cleared up and the story ends happily.

The double exposure process is not employed at all. Its absence is not regretted, for nowadays the dual role offers many an opportunity for a double exposure, which is oftentimes confusing as well as unnecessary, as it only affords a chance for the director to prove that he is proficient in all the arts of technical photography, and very little opportunity is afforded the star to exercise his or her individual ability.

Some may be apt to criticize the anti-climax that follows the real termination of the story. It explains the connection of the two girls—how when scarcely a week old their mother died and one of them was adopted by the policeman. But it is fitting that the explanation should follow. It is a trifle long perhaps, but altogether proper and correct.

A good atmosphere is attained and held throughout the picture, the realism of the underworld contrasting strikingly with the faithful precision followed in obtaining the correct settings for a well-to-do police captain's home.

Thomas McEvoy and Hayward Mack are well cast in the respective roles of the lover and father. In its entirety the picture will be heartily appreciated. Success is sure to accompany it.

"THE FIREMAN AND THE GIRL"

(Pathe—Three Reels.)

REVIEWED BY CLIFFORD H. PANGBURN

THERE is an unusually fortunate combination of exciting and humorous incidents in this picture. These are used to tell an interesting story in an entertaining style. The exterior scenes are most attractive, and offer a wide variety of rural and woodland views. Good photography adds to the value of the film, the various scenes about the river and the cave being particularly well done.

The cast includes players who can be depended upon to give a good interpretation of their parts. Thurlow Bergen appears as the stalwart fireman. His acting was by no means all pleasure as with Robin Townlee, who plays Jim, he had to roll downstream through a long series of rapids, which are just a bit too uproarious for comfort.

Elsie Esmond is seen as "the girl." She is a little barefoot country lass, and she is one with whom many men besides the fireman would be charmed. She handles her difficult role without affectation. Frank Brownlee makes a realistic farmer.

Larry, the most popular member of a city fire company, goes to the country for a vacation. An accident to the carriage which is taking him from the station leads to his acquaintance with Sarah Lane, the adopted daughter of a farmer. They are soon in love, but the girl's foster father has planned to have her marry his son, and the two object strongly to the new attachment.

Learning that the girl is planning to elope they carry her to a cave under a waterfall. The fireman locates her and reaches her by a rope let down over the face of the fall.

Surprising the guard they reach the office of the local justice of the peace and sheriff. Taking him in their carriage they hurry to the railroad station. The justice finishes the marriage ceremony on the platform, and the young couple leave on the train just as the angry suitor and foster father arrive. Later they invite the country folks to the city and have a happy reunion. Incidentally the girl calls out the fire department for the benefit of the visitors.

"SCARS OF POSSESSION"

(Essanay—Two Reels)

REVIEWED BY T. S. MEAD

A PICTURE taken from a story in "Munsey's Magazine" that is particularly well suited for production on the screen. The producer has spared no pains in making this a remarkably good piece of work from the start to the finish. The hospital scene in which the operation of transfusing blood from one person to another takes place, is so carefully worked out in every detail that only a surgeon, and a sharp-eyed one at that, would suspect that a real life was not at stake.

The other scenes, laid principally in wealthy homes, require a skill which is not lacking on the part of the producer to keep the entire production up to the high standard set by the hospital scene. These little attentions to detail, and the strict elimination of any incongruity of the settings certainly add much to the realism of the picture and are worthy of the highest praise.

The part of Payne Forsythe gives Francis X. Bushman a chance to display a lot of his ability, and Beverly Bayne will make a decided and perfectly deserved hit as Louise. Bryant Washburn, John Cossar and Harry Duncanson play respectively the devoted brother and the two physicians most convincingly.

The death of his father leaves young Payne Forsythe entirely alone in the world. The Forsythe money has gone; the Forsythe family had died. One desperate situation tumbles after the other. Tossing the last of his fortune into the "street," Payne leaves town for a year. He returns penniless, with nothing in sight. A newspaper advertisement attracts his attention, and he is selected from among a dozen applicants, to give up some healthy blood to save a young woman's life at a nearby hospital. The operation is successfully performed, but Payne is not allowed to see the girl's face, or know her identity.

A week later he leaves the hospital, but with a gnawing desire to know who the girl was. The incident acts as a turning point. Payne meets an old friend and goes to work on the stock exchange. Two years later he is a partner in the business, with a tidy personal fortune.

He meets J. Dukes Cortwright, a young millionaire, and falls in love with Cortwright's charming sister, Louise, at a bridge party. Time passes and Payne realizes his love is not returned. Heart-broken, he questions Louise one evening and is dumbfounded when she shows him a scar on her wrist and tells him she feels she belongs to an unknown young man, who gave his life blood to save her in an operation two years before. That's why J. Dukes Cortwright, coming a moment later, beholds his dearest friend kissing his dearest sister.

"THE CHOCOLATE SOLDIER"

(Daisy Feature Film—Five Reels)

REVIEWED BY H. S. FULD

THIS feature, which is a revival of the musical comedy of the same name, was given a special showing at Weber's theatre. The original comedy was one of the most popular and successful shows of its kind, that ever ran. The unusual hardships in filming a performance of this kind have been encountered, for the original was helped, to a large extent, by the catchy and tuneful airs as well as the spoken parts of the actors.

This means that most of the humor and wit that made the original so successful is not possible in the production. However, the action and situations as brought out by the actors are of such a kind as to make up in a large measure for these losses.

The cast for this film production was made up as far as possible of the original cast as played in the stage production. There is no fault to be found in either the acting or the story itself as filmed. It is complete and all the principal scenes that went so far to make the comedy a success are shown.

The original story, the original cast and from the looks of things the original interior stage settings were resuscitated for this production. The latter is the only fault that stares one in the face through the entire production.

It is really too bad that such a production should be spoilt in this manner. It is really so obvious, these painted interior settings, that the painstaking care of the cast and directors should go for naught. The exterior settings leave nothing to be desired. They are well chosen and the scenes about the castle are wonderfully well taken. Some may think the war scenes in the first two reels a trifle too long and hardly enough soldiers used to make them

seem realistic, but as it is a comedy these minor trifles might be overlooked.

The photography is, on the whole, fair; the double exposure is a little crude and rather indistinct in spots; but all this would be lost sight of if the interior settings had appeared more "real."

The plot of the story, showing the fugitive soldier taking refuge in the house of the enemy's commanding officer, and all the situations brought out where he is protected and shielded in every way by the wife and two daughters, bring out scenes which are really funny. His escape in borrowed clothes with the photograph of each of the three women stowed away in different pockets of his coat unknown to him brings out additional comedy, which is treated in the most humorous manner.

On the whole, if it were not for the interiors as previously mentioned, "The Chocolate Soldier" would make good.

"THE WITNESS INVISIBLE"

(Blinkhorn—Three Reels)

REVIEWED BY CLIFFORD H. PANGBURN

EVEN without the excellent story which is told in this picture it would be well worth seeing as an example of the best in the photographic art. Nearly every scene contains something unusual in the line of photography, while a large number of them are almost unique.

The story concerns the use of a camera to obtain evidence in a murder case. In this connection several scenes take place in a photographic dark room during the developing and printing of the pictures. These scenes are decidedly realistic, the actual appearance of the image on the photographic plates and paper being shown. Several incidents which take place in a chemical laboratory are also shown in a convincing manner. The manufacture of imitation diamonds would hardly deceive anyone familiar with chemistry, but to the ordinary audience will seem very striking.

The acting is in keeping with the photography, and all of the principal parts are handled in a skillful manner, particularly those of the hero and his father.

George Neville, son of a professor of medicine, has promised



"IT WAS THE HAND OF THE UNSEEN!"

a vaudeville actress that he will make her some artificial diamonds by a process he has discovered, and thus win her great publicity. As he does not care at all about the woman and does not want to be seen in her company he wears a mask when he goes to the theatre for some preliminary experiments.

A jealous rival of the actress and her lover arrange a camera so as to take pictures in the dressing room which the chemist is visiting, and thus learn his identity. An accident results in the discharge of a pistol and the death of the actress. The young man's father is compelled to hand him to the police, as he believes him the murderer.

The jealous couple produce the pictures which seem to establish the guilt of the chemist, but withhold others which prove his innocence. The police discover these, and thus learn that the woman's death was an accident. The innocent man is discharged.

Altogether a picture of much merit.

INTERESTING FILM REVIEWS

PRODUCTIONS FROM ALL PROGRAMS

GENERAL FILM PROGRAM

"The Prince Party." (Essanay. Two reels. Fri., Nov. 13.)—A story clever enough in itself to make a decided hit; but add to this Francis X. Bushman at his best and Beverly Bayne in a role particularly well suited to her charming personality, then spare no pains in skilfully producing it, and the result is a picture that is well worth every inch of its 2,000 feet. A gentleman hobo is called upon at the last moment to fill the place of the missing prince in a house party, given by the newly-rich, title-seeking American family. After some thrilling experiences, the supposed hobo falls in love with the beautiful daughter and is discovered to be the lost prince, who disguised himself to seek adventure. He certainly found it and incidentally found his queen in the daughter of the delighted parents.

"The Serpent Comes to Eden." (Lubin. Mon., Nov. 23.)—The eleventh of the "Beloved Adventurer" series. Betty's enemies make her believe that her husband is not only ashamed of her, but in love with another woman. Thus they induce her to leave her happy and faithful husband. He is left almost overcome with grief and with no idea as to the reason for his wife's act. The usual cast is seen.

"The Level." (Vitagraph, Mon., Nov. 23.)—A young settler marries a girl who has been brought up in the wilds, among rough men. She mistakes his kindness for weakness and will have nothing to do with him, until he discovers the cause of her trouble and adopts a brutal attitude. Thus he shows her the mistake she has made and they find happiness. Myrtle Gonzalez and Alfred Voughburgh head the cast.

"Out of Petticoat Lane." (Selig. Two reels. Mon., Nov. 23.)—A melodrama featuring Adda Gleason and Edith Johnson. Meg, a poor laundry girl, is befriended by a wealthy engaged couple. Afterwards she incurs the jealous enmity of Jessie, who works in the same laundry. Jessie unsuccessfully tries to kill Meg. Later, with the aid of her rich benefactor, forgiving Meg reforms Jessie. The brutal bully about whom all the trouble arose is soundly thrashed, and everything is "olvely" again. There are lots of audiences who will find this story not only elevating but interesting. It is well produced, and the acting is good. On the last reel are "The Seligettes of Doc. Yak."

"Seligettes of Doc. Yak." (Selig. Mon., Nov. 23.)—On the same reel with "Out of Petticoat Lane." It shows Sidney Smith, of the Chicago "Tribune," drawing a cartoon of Doc. Yak playing golf. It is a real comedy and will bring many laughs.

"Swedie at the Fair." (Essanay. Mon., Nov. 23.)—A good Swedie comedy with a thrilling automobile scene. Swedie has a great time with her donkey at the county fair. It fails to take any blue ribbons, but Swedie takes one for it. Then, she and her pet get into a racing car and go for a real joy ride around the race track with Ben Turpin and his comic policemen in hot pursuit. Finally, the machine crashes into a tent and is blown up.

"The Theft of the Crown Jewels." (Kalem. Two reels. Mon., Nov. 23.)—Although this story is not new and the ending is quite obvious, it is well constructed and acted commendably. The minor point of an exceptionally small crowd attending a court wedding does not mar it. In this picture it is said that Alice Joyce, the star, wore a million dollars' worth of jewels and was clad in a three-thousand-dollar gown. Guy Coombs plays opposite Miss Joyce and Jere Austin is the heavy. A political marriage is necessary to set two European countries on more substantial ground. The prince objects and goes to America where he meets the princess attempting to pawn the crown jewels. A good series of events terminates the picture.

"Beyond Youth's Paradise." (Essanay. Tues., Nov. 24.)—From a "Munsey magazine" story dealing with the love of an English army officer for an unhappily married woman. The wife refuses to leave her brutal husband, so the officer returns home. Years later, he finds that the widow with whom his nephew is in love, is none other than this woman. Her love for her old

suitor returns, and the nephew realizes that youth's Paradise is ahead of him.

"The Old Flute Player." (Vitagraph. Two parts. Tues., No. 24.)—A flute player in a London theatre goes to America with his pretty daughter. A young man of wealth meets the girl on the steamer and gets her a place as a companion to his mother. That haughty person suspects that her son is in love with the girl, and thinking she sees a chance to discredit her, attempts to do so. She not only discovers her mistake, but that the flute player is a count who has been banished for two years only and can now resume his rank. Edith Storey appears as the count's daughter.

"Mother's Baby Boy." (Lubin. Tues., Nov. 24.)—A slapstick comedy of an effeminate young fellow who writes to his mother of the way in which two rude fellows are annoying him. Mother appears on the scene with a prizefighter hired for the occasion, and trouble follows. On the same reel with "He Wanted Chicken."

"He Wanted Chicken." (Lubin. Tues., Nov. 24.)—A comedy based on the dual meaning of the word chicken. Some amusing situations. On the same reel with "Mother's Baby Boy."

"The Scapegoat." (Selig. Tues., Nov. 24.)—A Tom Mix drama that contains some unusually exciting scenes. There is a real thrill when Tom Mix on horseback snatches Goldie Colwell from a buckboard which is being drawn at a terrific speed by a runaway horse. Tom Mix as sheriff captures a bank robber, and finds that he is a brother of the girl he loves. The robber is allowed to escape, and the sheriff himself leaves the country.

"Tough Luck Smith." (Kalem. Tues., Nov. 24.)—The old story of the poker player attempting to evade his watchful wife. Rather below the average at first, but the climax and the subsequent scenes are humorous. Ethel Tearse as the wife assumes an exceptionally grotesque disguise. John Brennan is the husband.

"The Girl and the Explorer." (Kalem. Two reels. Wed., Nov. 25.)—Tom Moore directed and played the lead in this offering, and made an excellent job of it from all standpoints. In its class of comedy-dramas, the picture is one of the best. Marguerite Courtot plays the girl in the case with all her usual charm, and Richard Purdon is good as her father. Makato Inokuchi is the Japanese butler. In order to obtain the explorer's story, the daughter of the publisher enters his house in the capacity of parlor maid. The romance that follows is very pretty and delightful. No one will regret having seen this.

"The Making of Him." (Lubin. Two reels. Wed., Nov. 25.)—A society girl realizes that her fiancé is leading a useless life which can only result in unhappiness. She tells him that he must take a four months' course in a naval training station or never see her again. He takes the course, while two naval officers industriously court her. She has no intention of accepting them, and when she finds that her lover has been made a man by hard work, and is helping in his father's business, she renews their engagement.

"The Fable of Aggie and the Aggravated Attacks." (Essanay. Wed., Nov. 25.)—A very well-produced Geo. Ade fable, which makes a really clever comedy. Aggie, having survived all the childhood ailments, is hard hit by one fad after another. Photography, physical culture, the stage, art and woman's suffrage—she works each of these to death. When the love microbe strikes her, her long suffering parents receive her suitor as a true deliverer, and rush the match through before the victim has time to change his mind.

"The Butterfly's Wings." (Selig. Wed., Nov. 25.)—A spoiled society girl goes to a quiet seaside town to escape her host of admirers. Here a flirtation with one of the villagers follows his rescue of her from drowning, but in winning his heart, she unexpectedly loses her own. His former sweetheart persuades her to unselfishly give him up, and the butterfly returns home to marry a wealthy suitor. A good play well acted by Bessie Eyton and Thomas Santschi.

"Netty or Letty." (Vitagraph. Wed., Nov. 25.)—A young man at a summer resort is much interested in Netty. She has a twin sister named Letty, who is her exact double in appearance.

Some friends arrange things so that the young man meets the girls in a bewildering succession with laughable results. Dorothy Kelly and James Morrison are featured.

"Snakeville's Reform Wave." (Essanay. Thurs., Nov. 26.)—Sophie, at the head of a band of Suffragettes, succeeds in voting Snakeville dry. The henpecked Slippery Slim and Mustang Pcte, much to their disgust, are forced by their wives to aid them in the dry campaign. The ludicrous situations are well played up by the regular Snakeville cast.

"Cause for Thanksgiving." (Vitagraph. Thurs., Nov. 26.)—Sonny Jim exchanges his father's Thanksgiving turkey for a little black pickaninny, the latter being turned over by an unappreciative sister who longs for turkey. Both find that their families are not exactly pleased. The result, however, is that the negro family are given enough by Sonny Jim's father to make their Thanksgiving a real one.

"Was His Decision Right?" (Lubin. Two reels. Thurs., Nov. 26.)—The familiar melodramatic situation of a young man reformed through his love for a woman, who, unknown to him has been a woman of the streets. The lover is the nephew of a clergyman, who is fully aware of the girl's past. He is about to tell the man, but is restrained by the act of a crippled girl. Lillie Leslie and Joseph Smiley play the leads.

"Ham, the Iceman." (Kalem. Fri., Nov. 27.)—A snappy slapstick comedy featuring Lloyd Hamilton's extraordinary ability in this direction. Ham gives up his job as street cleaner to become an iceman, because he thinks they have an easy time. Ham finds there is nothing easy about it, although it looks fine at the start. A picture which will get a laugh almost anywhere.

"A Surprise Party." (Selig. Fri., Nov. 27.)—A farce comedy containing many humorous situations, which arise from Mrs. Brown appearing with a hat that Mrs. White had seen on Mr. White's office desk. The cast includes Elsie Greeson, John Lancaster, Lillian Leighton and Sid. Smith.

"He Waits Forever." (Lubin. Fri., Nov. 27.)—A poor Mexican is in love with a girl and goes away to make his fortune, the girl promising to wait forever. Having heard nothing from her lover at the end of six years, she marries another man. Later the lover comes back at the head of a rebel army, and seeks vengeance for what he terms the girl's lack of faithfulness. He dies by the plan he had arranged for the girl and her husband.

"The Musical Barber." (Vitagraph. Fri., Nov. 27.)—An entertaining comedy of a barber who discovers to his discomfort that music does not always charm, at least his style of music.

"Convict, Costumes and Confusion." (Vitagraph. Two reels. Sat., Nov. 28.)—A convict escapes and arrives at a hall where a costume ball is being held. An old sport is there with a girl. He learns that his wife is coming and gives the convict one hundred dollars to change costumes. The convict is glad to do it, but when the angry wife arrives he wishes he was back in the dear old prison. He escapes from her but is eventually caught. Billy Quirk appears as the convict.

"The Girl at the Throttle." (Kalem. Sat., Nov. 28.)—The third in the "Hazards of Helen" series. Like the others it is a railroad story and is filled with a number of fine views of moving trains and engines. When a hunter accidentally wounds the engineer of a light engine, the fireman of which has left it, Helen runs a yard engine after the express, catches it and tows it back out of danger while the passenger engine meets the one that is running wild, and stops it successfully. Helen Holmes and the regular cast are seen.

"The Servant Girl's Legacy." (Lubin. Sat., Nov. 28.)—The well known situation of a servant girl of no attraction who becomes the most sought after spinster in the town on receiving a telegram that she is her uncle's sole heir. When his estate is found to be twenty-five dollars the suitors vanish. On the same reel with "You Can't Beat Them."

"You Can't Beat Them." (Lubin. Sat., Nov. 28.)—A tightwad refuses to give his wife any

money. Her mother concocts a scheme which soon makes him loosen up a bit. On the same reel with "The Servant Girl's Legacy."

"The Fates and Ryan." (Selig. Sat., Nov. 28.)—An interesting and exciting drama built around the intelligence of a cleverly-trained police horse, who aids his master in the single-handed capture of a band of counterfeiters. A love story is interwoven, in which the abused niece of one of the counterfeiters marries the mounted policeman.

"Broncho Billy's Double Escape." (Essanay. Sat., Nov. 28.)—Broncho Billy, an outlaw, is captured by the deputy sheriff. That night he not only escaped, but holds up a poker game, at which the deputy sheriff has lost heavily.

UNIVERSAL PROGRAM

"The Moccasin Print." (Frontier. Sat., Nov. 14.)—A lively story of a western girl who becomes insanely jealous of the woman who replaced her in the cowboy's heart. She repents finally and the other two are allowed unmolested happiness. Joe Franz is the leading player. This picture takes the place of "The School Teacher at Angel Camp."

"A Relic of Olden Days." (Frontier. Sat., Nov. 21.)—A man and his daughter unearth an implement used by some member of the Stone Age. The father then tells the girl a love story laid in that time. The story is not exceptionally good but affords fair entertainment. Fred Church is not quite suitable for the part of a prehistoric man. This picture takes the place of "Man to Man."

"The Groom's Doom." (L. Ko. Sat., Nov. 21.)—Rather low comedy, which is humorous until the finale, when all the actors end up wallowing in a mudhole. The muscular suitor finally meets his superior when he forces that gentleman into a boxing match. The photography is poor in places.

"Black Hands." (Sterling. Mon., Nov. 23.)—Felix wanders to the cellar and invades a jar of jam; he then wanders up through the house to the attic leaving marks of his presence behind him. His father, who was threatened by an Italian organ grinder, is in deadly fear that the black hand is after him and consequently calls out the police force and a detective. The police are the funniest part of the picture; they are led by a comedian who gives promise of a bright future.

"Noodle's Return." (Sterling. Not to be released.)

"As We Journey Through Life." (Nestor. Tues., Nov. 24.)—Murdock MacQuarrie in a character role. The picture is a novelty. As an old man MacQuarrie looks through the family album, the pictures fade out, and the important parts of his life are enacted again. This is a very pleasant offering.

"The Heiress and the Crook." (Eclair. Two reels. Wed., Nov. 25.)—An adventurer masquerades as a count and succeeds in winning the heart of a young debutante from her meaner appearing fiancée. Toward the end of the picture the count is unmasked by the other man. This is a fair offering, conventional but interesting. The actors are new, and their actions betray their ignorance of screen technique, yet they are sincere and energetic in the rendition of their parts.

"Dot's Elopement." (Sterling. Thurs., Nov. 26.)—The most laughable feature of this comedy is the chase, in which a watering cart and two automobiles partake. Dot, who is the daughter of a poor man, is given as the wife-to-be of the mortgage holder. Then her real beau discovers he has inherited a fortune, which leads to the elopement and a hasty marriage. Max Asher has a small part as the father.

"The Tricky Flunky." (Joker. Wed., Nov. 25.)—Ernest Shields in another new role. Quite a bit of the action transpires in the kitchen. Many laughs will be caused. The supporting cast is comical.

"In Taxi 23." (Nestor. Fri., Nov. 27.)—Al Christie's company, led by Ed. Lyons, Victoria Forde and Lee Moran in a rollicking, slap-stick burlesque, on the girl from the country being stolen from her lover by the villain. Laughable from start to finish.

"He Married Her, Anyhow." (Joker. Sat., Nov. 28.)—Very humorous. All the sources that Louise Fazenda and William Franey possess for creating fun are utilized to their fullest extent.

MUTUAL PROGRAM

"The Folly of Anne." (Majestic. Fri., Nov. 13.)—A girl goes to the city to sell her stories, but meets only with failure. Turned out of her boarding place, she obtains entry to a fine house by accident. She supposes the owners to be away, and is surprised at a meal of bananas taken from the dining room by the entry of the proprietor, a young publisher. Learning his occupation she makes him read a story at the point of a somewhat shaky revolver. He buys it and others, but no one else will follow his example. When she is about to go home discouraged he tells her of his love, and they are both happy. Well acted and interesting, with a few good comedy touches.

"A Fortune in Pants." (Royal. Sat., Nov. 14.)—A slapstick comedy featuring Louis Simon. A jeweler's confidential messenger is carrying a diamond worth \$30,000. He hides it in his trousers' pocket, as he thinks it a place no one would look for. While taking a bath his trousers are stolen. They then pass through many hands, but are finally recovered with the diamond. The men who have had the pants nearly die of nervous prostration on realizing what they have missed.

"Out Again—In Again." (Komic. Sun., Nov. 15.)—Baldy Belmont. "Tammany Bill" Young and Fay Tincher are featured in this amusing comedy of errors. Henpeck plans to pretend to go crazy. Then two of his pals are to come as policemen, and take him out to enjoy a quiet poker game. Mrs. Henpeck discovers the plan, and when real policemen come in search of a thief beats them up. The burglar causes additional complications and finally everyone lands in jail. Mrs. Henpeck at last consents to get her husband out, but his two pals are left behind the bars to meditate on their sins.

"The Odalisque." (Majestic. Two reels. Sun., Nov. 15.)—In this case the odalisque is a slave of fashion. A simple shop girl, through her longing for good clothes, allows the head buyer to furnish her with money. He attempts to make free with her, but her discarded sweetheart comes to the rescue. Excellently played by Blanche Sweet as the girl, Wallace Reid as the buyer, Henry Walthal as the discarded suitor, and Robert Harron and Miriam Cooper as a happily married couple.

"Redbird Wins." (American. Two reels. Mon., Nov. 16.)—Two professional crooks make the acquaintance of a southern colonel who has a warm heart but little discretion. They win much money by crooked gambling and plan to get the rest by doping his horse which is the favorite in a big race. The suitor of the colonel's daughter discovers the plot, and frustrates it without the crooks knowing of his action. Redbird wins, although the girl has to ride him because the jockey is thrown. Everyone is happy. Good sets and photography, and altogether a picture that will please.

"Our Mutual Girl, No. 44." (Reliance. Mon., Nov. 16.)—Margaret visits Mr. Tappe's millinery establishment and examines the latest fashions in women's hats. Later Margaret and her aunt, Abbie, journey to an old house, and hear a sad love story from its aged inmate, Norma Phillips impersonates the woman in her story. This reel affords Miss Phillips more of a chance to display her ability as an actress than any of the others.

"The Little Country Mouse." (Majestic. Tues., Nov. 17.)—This is a story of a simple country girl who takes a much desired fling at society life, and finds it greatly disappointing. The plot is simple but very well constructed. It is played with force by Blanche Sweet as the girl, R. A. Walsh as the heavy and Wallace Reid in the role of the lieutenant, the savior of the girl.

"Pawns of Fate." (Thanhouser. Two reels. Tues., Nov. 17.)—This story has the marks of a very interesting tale, but unfortunately it is produced poorly. A crook who desires to secure the pardon of his brother kidnaps the governor's twin daughters, and refuses to give them up until a pardon is promised. Thanks to the efforts of a detective they are rescued.

"The Hidden Message." (Reliance. Wed., Nov. 18.)—Directed by Arthur Mackley, who appears in his familiar role of sheriff. The story is that of two tramps, who, after receiving a severe drubbing from a ranch owner, proceed to kidnap his daughter. She is rescued by the sheriff, who is materially helped to make the capture by his little daughter.

"Nipped." (Domino. Two reels. Thurs., Nov. 19.)—A story laid in Mexico, concerning a plot of some Japanese who are attempting to

further their power there. The story takes some time in getting under way, but after it has, it is very entertaining. It is full of action and will surely be well received.

"The Noise of Bombs." (Keystone. Thurs., Nov. 19.)—Charles Murray as a member of the police force gets himself into all manner of awkward situations, some of which are very funny. Dynamite is used with a careless regard of its treacherous nature. Not quite up to Keystone standard, but very funny.

"Love Finds a Way." (Royal. Sat., Nov. 21.)—On the eve of his marriage a bachelor rents his apartment to a man who quarters his bride in the rooms. After a gay party the bachelor forgets he has rented his apartment and goes home as usual. He finds his bedroom occupied, and goes to sleep on the mantel. In the morning the father of the girl who has taken his apartment tries to force him to marry her, fearing that the escapade has compromised her. He is thwarted, and instead the two couples have an impromptu double wedding. Louis Simon is featured. A comedy of semi-slapstick type.

"Fatty's Wine Party." (Keystone. Sat., Nov. 21.)—This picture is a roar from beginning to end. Syd Chaplin makes his first appearance for this company and is excruciatingly funny as a waiter. Roscoe Arbuckle and Mabel Normand also appear. Fatty takes his girl into her favorite cafe, accompanied by a twenty-five cent piece. A number of his rivals enter and proceed to order champagne, ten course dinners, and other expensive eatables. Then they leave. Fatty, being unable to pay the check, is beaten up by the waiter. He leaves the place minus a few of his clothes, but Mabel stays by him.

"In the Candle Light." (American. Two reels. Mon., Nov. 23.)—A fair story, but the introduction of such a large number of characters makes it hard to follow. The photography, scenes and sets are superb. A jealous husband deserts his wife, taking with him his young daughter. Years later, with the marriage of his daughter, the old man discovers that he had grossly misunderstood his wife. In the cast are: Josephine Ditt, Jack Richardson, Harry Von Meter, Vivian Rich, William Garwood and Charlotte Burton.

"The Cross in the Desert." (Broncho. Two reels. Wed., Nov. 25.)—An effective picture, not exactly true to life but well constructed and highly absorbing. Richard Cummings is cast as the leader of a band of tramps, who take a terrible revenge on the division manager of a railroad, who has caused them to be thrown off the train whenever caught. They dress him as a hobo and let him have a taste of his own medicine, and he does not survive the test. A sad story is told in the bargain which fits well with the more prominent plot.

"The Mills of the Gods." (Domino. Two reels. Thurs., Nov. 26.)—The locale of this picture is Holland, and a gentleman who has just returned from there told us that the atmosphere is perfect. At any rate, it is not an American atmosphere; the principals are dressed in Dutch clothes and the scenes and sets are realistic. The story, besides being quite unusual, is entertaining from start to finish. It relates the life of a miserable miser, who lost his wife through the love of money. Finally his son kills him in a quarrel. A love story appears also, and makes the film doubly entertaining.

"A Crook's Sweetheart." (Kay-Bee. Two reels. Fri., Nov. 27.)—The crook's sweetheart becomes jealous, because he is paying so much attention to another woman. She betrays him into the hands of the police, then relents and tries to save him, but is too late. The crook escapes from his captors by jumping off a moving train, and attempts to take the girl's life, but a policeman interferes in the nick of time. The jump from the train is a real thriller. Leona Hutton is cast for the role of the girl.

"Before and After." (Royal. Sat., Nov. 28.)—A burlesque of the most extreme type depicting the change brought about in a man by a transfusion of blood. Louis Simon plays the leading part.

ECLECTIC-PATHE

"Help! Murder! Police!"—A slapstick comedy of the rapid-fire type. There is a number of laughs in this release, and though this number is of the variety that is all the go this season, it has sufficient scenes and situations that are "different" to make a good picture. A grotesque police department, same for department, and some really funny rural characters furnish the fun and altogether are good comedians.

"The Crown of Richard III." (Pathé. Three reels.)—This film presents the history of Richard III from the time when, as the Duke of Gloucester he poisoned the king of England, to the murder of the princes in the Tower and the Duke's seizure of the throne. The historical facts are followed closely. The picture was made in London and Paris and contains a number of effective scenes supposed to be in and about Westminster and other places identified with the story. The costumes and the trappings of the horses are correct, and of much excellence. The acting of most of the characters is good.

"The Police Dog." (Pathé. Split reel.)—An animated cartoon of extraordinary ingenuity. The police dog causes his master no end of trouble while pursuing a suspicious person in the shape of a cat, as well as later. "The Friend of Birds" is on the same reel.

"The Friend of Birds." (Pathé. Split reel.)—A colored picture showing some bird's nests and the method of tagging wild birds for the purpose of studying their migrations. The picture was made in France, but is of special interest in this country now as this method of tagging birds is now practised by American ornithologists. "The Police Dog" is on the same reel.

"Whiffles Wins the Winsome." (Pathé. Split reel.)—One of the popular Whiffles comedies. Whiffles flirts with a girl over the telephone, but when he goes to meet her he has a cruel surprise. Later fortune is kinder, thanks to Whiffles' ingenuity. "Colombo, Ceylon" is on the same reel.

"Colombo, Ceylon." (Pathé. Split reel.)—A beautiful colored film showing points of interest around the famous capital of this tropical island. On the same reel with "Whiffles Wins the Winsome."

"Cupid's Pranks." (Pathé. One reel.)—Father and mother each have picked a husband for their daughter. While they and the suitors are fighting, the man of the girl's choice succeeds in marrying her. What is more, he gets the parents' consent. An entertaining comedy with some lively automobile scenes and many laughable situations.

"Dr. Jekyll and Mr. Hdye." (Starlight.)—A burlesque on the story of Stevenson's and very cleverly put on. Novel situations introduced in a novel manner, mechanical effects galore, and keeping the observer in suspense as to what will happen next all go to help make this number different from the general run of comedies. The final scene is especially novel, in that one is at a loss to see how the author is going to get the hero out of the fix he is in; and the climax is a surprise. The story never lags, and one laugh follows quickly on the heels of another.

"Everyman." (Two reels.)—An allegory featuring Constance Crawley in the part of "Everyman" and Allen Maud as the angle of "Death." This release is replete with double exposures and trick photography, and though dealing with a very delicate subject is handled in a masterly manner. The settings used show great care in the choosing, and the exterior scenes, especially the "Valley of the Shadow," are beautiful. The photography is wonderfully clear and distinct, the cast shows exceptional ability, and too much credit cannot be given to the director. An out of the ordinary run of pictures.

WEEKLIES

"Mutual Weekly, No. 99." (Tues., Nov. 17.)—Some of the interesting events in this number are: The ruins of the lodging house fire in New York in which six people lost their lives; the destruction of the menacing chimneys left standing after the Salem fire, by dynamite; the prize turkeys for the White House table; the illustration of the modern dance, the Lula Fado; besides a few other domestic happenings and several views from the war zone.

"Hearst-Selig News Pictorial, No. 74." (Selig. Thurs., Nov. 12.)—A timely subject which holds much space in this reel is the attempt of the government to stamp out the foot and mouth disease now infecting cattle. Views of the Union Stock Yards of Chicago are shown. Philanthropic work conducted by Americans for the sufferers in the European war, and scenes from Europe are other interesting subjects. A number of home events complete the reel.

"Animated Weekly, No. 139."—This news film features a number of scenes from the war zone, chiefly in the vicinity of St. Armands, Belgium. A number of scenes showing further war preparations in England are also shown, including views of the camel cavalier, of the British Indian troops. Besides the war there is a number of interesting happenings in the United States are shown. The film closes as us Hy Mayer's cartoons.

"Animated Weekly, No. 140."—This reel contains pictures of news events from widely scattered parts of the world. As usual just now the war views are of the most interest. A number of these are from the vicinity of Bruges, Belgium, and among them is the latest picture of Albert, the heroic king of the Belgians. Other views are from England and show the arrival of Canadian troops, the celebration of Trafalgar Day and scenes at the army concentration camps. The German cruisers which figured in the recent fight off the coast of Chile are also pictured. Among the American scenes is one showing President Wilson and ex-President Taft as guests of honor in Washington.

"Hearst-Selig, No. 71."—In this issue will be found a number of interesting pictures from the European seat of war in addition to the regular local events. Among the latter are a specially posed picture of Christabel Pankhurst, famous English suffragette; pictures of the race between Directum I. and William at Grand Rapids, and of a mine test in New York harbor. The U. S. battleship "New York" is shown plowing its way at full speed, under forced draft. The photography is unusually clear and distinct. Among the war pictures are infantry, cavalry and artillery hurrying along roads and through fields in the retreat from Antwerp.

"Mutual Weekly, No. 98."—Some very interesting pictures from Europe, showing refugees pouring from Antwerp; Indian troops joining the Allies; effect of French guns, and a number of others. Eureka, Cal., celebrates the completion of the new \$13,000,000 railroad, which is its first rail connection with the outside world. Pictures of the fight for the lightweight championship of the world, taken in Madison Square Garden, New York, and a number of others, including the U. S. government tests of aeroplanes at San Diego, Cal. Catherine Elliot and Clay Basset demonstrate the new fashions in modern dances. An unusually pleasing number.

"Hearst-Selig, No. 73."—An out of the ordinary run of weeklies in that it shows how the "400" spends its days at fashionable winter resorts. This is from Hot Springs, Virginia. A number of current views of the great war are shown, from Plymouth, England; Ghent, Belgium, and Salisbury, England. Two chimneys left standing as monuments of the Salem fire are razed, making a very spectacular scene. The Poet Longfellow's house is shown at the dedication exercises, and Los Angeles contributes scenes of seven truck loads of Christmas gifts for Europe's war orphans.

WARNER'S FEATURES

"Stung by the Bee." (Premier-Warner.)—Everybody in the western town is "sore on" the "Bee," a paper coming out every Friday, perhaps. The "Bee" owes them all money; the editor and the "devil" duck whenever a person enters the door. An actress enters the town, and hatches the idea of running a popularity contest. Things boom and the two make off with the money. A number of real laughs in this, although the idea is old.

"The Prospector's Warning." (Premier.)—A good offering with the subtitles in verse. The maid is warned by the prospector against going too far in teasing her lover, and by the prospector telling his own story to her she sees her error. The photography is very good and the dissolving of the scenes of the past into those of the present is done in a masterly manner. The cast is well chosen and really marks this release with exceptionally good acting.

INCORPORATIONS

REX FEATURES, INC.; motion pictures and theatrical; \$4,000; Manhattan; Wm. and Celia

ARE YOU USING IT? THESE MEN ARE. SEE PAGE 51

"The plan is good. Extra heavy lines between each day's record would improve appearance of sheet."—A. E. NORTHEY, Orpheum Theatre, Sidney, Mont.

"It looks good to me, and will no doubt prove of value to all live exhibitors who want to keep tabs on their daily business."—W. H. WOOD, Pastime Theatre, State College, Pa.

Weisfeld, Walter J. Toner and one other, of New York.

STANDARD POLYSCOPE CORPORATION; theatrical and motion pictures; Manhattan; Wm. P. Cooper, of Chicago; Ormsby McHarg, Alfred Houston and one other, of New York.

HANCOCK PHOTOPLAY CORPORATION; theatrical and motion picture; \$150,000; Manhattan; H. E. Feldman, C. S. Skinner, E. C. Hill and two others, of New York.

MUTUAL CIRCUIT AND AMUSEMENT COMPANY, INCORPORATED; general theatrical; \$75,000; Manhattan; Jos. Pascocello, Jas. P. Clark, Root A. White and two others, of New York.

GREENBERG AND GORDON AMUSEMENT CO., INC.; theatrical and motion picture; \$5,000; Max and Louis Greenberg, Mayer Gordon and one other, of New York.

WORCESTER MOTION PICTURE COMPANY, INC.; general motion picture business; \$60,000; Manhattan; Harold Fink, of Englewood, N. J.; H. A. La Paugh, of New York, and E. C. Goodwin, of Worcester, N. Y.

MICA FILM CORPORATION; motion picture and theatrical business; \$25,000; Manhattan; Armin H. Mittlemann, of New York; Jacob Charlop, of Brooklyn, and Anna Hyman, of New York.

KINEMA RIFLE RANGE COMPANY, INC.; manufacture Kinematograph rifle ranges, moving pictures, shooting galleries, etc.; \$100,000; Manhattan; E. L. Dolder, Morris Perlman, Wm. Walling, of New York.

TERWILLIGER AND SHACKETT CORPORATION; motion picture business; \$20,000; Albany, N. Y.; Frank G. Terwilliger, Charles L. Shackett and Reuben F. Heaton, of Albany.

THE AMERICAN PLAY COMPANY, INC.; theatrical, music hall, moving pictures, restaurant, etc.; \$800,000; Manhattan; Elizabeth Marbury, Harold S. Budner, Emil Breitenfeld and two others, of New York.

TWIN BEDS CORPORATION; general theatrical, music hall, motion pictures, restaurants, etc.; \$2,000; Manhattan; Archibald and Edgar Selwyn and Crosby Gaige, of New York.

BENNED FILM COMPANY, INC.; motion picture and theatrical; \$2,000; Manhattan; Malvina and Edward Printz, Benj. Weinberg and one other, of New York.

MONTGOMERY-MOORE FILM CORPORATION; motion pictures; \$10,000; Manhattan; Hiram B. Danziger, Uly Hill and Abraham Canter, of New York.

HAMPTON AMUSEMENT COMPANY, INC.; advertising business; theatrical, manufacturing of moving pictures, etc.; \$10,000; Manhattan; Thos. McMahon, Anna Heimburg, William Lockhart, of New York.

FEDERATED FILM CORPORATION, INC.; motion pictures; Manhattan; Jno. M. Flynn, Emil Bulwinkle and Albert Honey, of New York.

At Springfield, Ill.: THE INTERNATIONAL MOTION PICTURE COMPANY, of Chicago. Capital stock, \$2,500; motion picture business. The incorporators are: Perry S. Patterson, Mellen C. Martin and Herbert Bebb.

THE PLAYERS' PRODUCING COMPANY, of Chicago. \$35,000. The company is to enter the theatre, moving picture and amusement business. The incorporators are: Thomas E. Vent, Charles F. Vogel and Henry F. Dickinson.

At Hartford, Conn.: OSCILAGRAPH COMPANY, of New Britain. Incorporated October 24, 1914, to make and deal in films, cameras, etc. Capital stock, \$50,000, divided into 400 shares, of \$25 each, and 400 shares of \$100 each. Commence business with \$1,000. Incorporators: W. M. Sanford, R. S. Kilbourne and J. P. Wakefield, all of Hartford.

At Trenton, N. J.: PANCHROMOTION, INC., Jersey City; production of motion pictures; capital, \$100,000. Incorporators: C. Raleigh, G. P. Kelley, Jersey City; W. V. D. Kelley, Brooklyn, N. Y.

ASTOR THREATRE COMPANY, Plainfield; capital, \$5,000.

At Dover, Del.: THE STAR FILM COMPANY, Wilmington, Del.; capital stock, \$300,000; to manufacture, sell and deal in motion picture films of all kinds; to conduct theatrical amusement of all kinds. Incorporators: F. D. Buck and M. L. Horthy, Wilmington, Del.

THE PERFECTOGRAPH MANUFACTURING COMPANY, New York City; to manufacture, sell and deal in and with moving picture films, projecting pictures, stereoptical views, etc.; capital stock, \$1,000,000. Incorporators: Anthony, B. Cavanaugh, Earle M. Wood and O. L. Holcrist, all of New York.

At Columbus, O.: THE VICTORIA AMUSEMENT COMPANY, Cleveland; moving picture theatre; \$5,000; M. T. Campbell, C. J. Ketts, F. M. Drew, D. C. Van Buren and P. D. Caldwell.

At Little Rock, Ark.: THE AMERICAN PHOTOPLAY COMPANY, a Tennessee corporation capitalized at \$200,000, has been chartered. The corporation has named J. A. Greif as its State agent. The Arkansas theatre operated by the foreign corporation is at 219 Main street in Argenta.

Day and Date	Titles of Films Booked	Release Date	Brand	No. Reels	Review appears in Motion Picture News of		Posters Used and Size	Reg-ular or Spe-cial	Cost	Advertising Used: News-papers, her als, slides, photographs, window cards	Weather	Total Admissions	
					Issue	Page						Matinee	Night
M O N D A Y													
	Remarks												
T U E S D A Y													
	Remarks												
W E D N E S D A Y													
	Remarks												
T H U R S D A Y													
	Remarks												
F R I D A Y													
	Remarks												
S A T U R D A Y													
	Remarks												
S U N D A Y													
	Remarks												

Record of Current and Coming Releases

GENERAL FILM PROGRAM

RELEASES OF NEXT WEEK

Monday, November 23, 1914.

BIOGRAPH—All on Account of the Cheese, C., and Thrown Off the Throne, C., 1000.....	16485
EDISON—His Chorus Girl Wife, D., 1000.....	16491
ESSANAY—Sweedie at the Fair, C., 1000.....	
KALEM—The Theft of the Crown Jewels, D., 2000....	16486
LUBIN—The Serpent Comes to Eden, No. 11 of the Beloved Adventurer Series, D., 1000.....	16494
SELIG—Out of Petticoat Lane, 2 Reels, D., 500, and Doc Yak Plays Golf, 500.....	16488
SELIG—Hearst-Selig News Pictorial No. 77, N., 1000..	
VITAGRAPH—The Level, D., 1000.....	16490

Tuesday, November 24, 1914.

BIOGRAPH—The Romance of a Poor Young Man, D., 2000	
EDISON—A Gypsy Madcap, D., 1000.....	16495
ESSANAY—Beyond Youth's Paradise, D., 1000.....	16496
KALEM—Tough Luck Smith, C., 1000.....	16501
LUBIN—Mother's Baby Boy, C., and He Wanted Chicken, C., 1000.....	16500
SELIG—The Scapegoat, W. D., 1000.....	16497
VITAGRAPH—The Old Flute Player, D., 2000.....	16498

Wednesday, November 25, 1914.

EDISON—The Temple of Moloch, D., 1000.....	16504
ESSANAY—The Fable of Aggie and the Aggravated Attacks, C.-D., 1000.....	16507
KALEM—The Girl and the Explorer, C., 2000.....	16505
LUBIN—The Making of Him, D., 2000.....	16510
SELIG—The Butterfly's Wings, D., 1000.....	16509
VITAGRAPH—Netty or Letty, C., 1000.....	16508

Thursday, November 26, 1914.

BIOGRAPH—The Way Back, D., 1000.....	16512
ESSANAY—Snakeville's Reform Wave, C., 1000.....	16513
LUBIN—Was His Decision Right? D., 2000.....	16514
SELIG—Hearst-Selig News Pictorial No. 78, N., 1000..	16517
VITAGRAPH—Cause for Thanksgiving, C., 1000.....	16516

Friday, November 27, 1914.

BIOGRAPH—His Old Pal's Sacrifice, D., 1000.....	16526
EDISON—The King's Move in the City, D., 2000.....	16518
ESSANAY—Scars of Possession, D., 2000.....	16520
KALEM—Ham the Iceman, C., 1000.....	16522
LUBIN—He Waits Forever, D., 1000.....	16525
SELIG—A Surprise Party, C., 1000.....	16523
VITAGRAPH—The Curing of Myra May, C., 1000.....	16524

Saturday, November 28, 1914.

BIOGRAPH—Little Miss Make Believe, C., 1000.....	16533
EDISON—The Last of the Hargraves, D., 1000.....	16527
ESSANAY—Broncho Billy's Double Escape, W. D., 1000	16528
KALEM—The Girl at the Throttle—Third Episode of the "Hazards of Helen," D., 1000.....	16532
LUBIN—You Can't Beat Them, C., and The Servant Girl's Legacy, C., 1000.....	16529
SELIG—The Fates and Ryan, D., 1000.....	16534
VITAGRAPH—Convict, Costumes and Confusion, C., 2000	16530

RELEASES OF THE WEEK AFTER

Monday, November 30, 1914.

BIOGRAPH—A Mother's Way, D., 1000.....	
EDISON—Wood B. Weed Goes Snipe Hunting, C., 1000	
ESSANAY—A Maid of War, 1000.....	
KALEM—Her Bitter Lesson, D., 2000.....	
LUBIN—Fate's Tangled Threads, Beloved Adventurer No. 12, D., 1000.....	
SELIG SPECIAL—In the Days of the Thundering Herd, D., 5000.....	
SELIG—Unrest, D., 2,000.....	
VITAGRAPH—Everything Against Him, D., 1000.....	
SELIG—Hearst-Selig N. Pictorial No. 79, N., 1000.....	

Tuesday, December 1, 1914.

BIOGRAPH—The Closing Web, D., 2000.....	
EDISON—The Girl of the Open Road, D., 1000.....	
ESSANAY—The Buffer, D., 1000.....	
KALEM—Bud, Bill and the Waiter, C., 1000.....	
LUBIN—Coupon Collectors, C., and for a Widow's Love, C., Split Reel.....	
SELIG—The Rival Stage Lines, C., 1000.....	
VITAGRAPH—Saved from a Life of Crime, D., 2000...	

Wednesday, December 2, 1914.

EDISON—A Double Elopement, C., 1000.....	
ESSANAY—The Club Girls and the Four Times Veteran, C., 1000.....	
KALEM—The Prodigal, D., 2000.....	
LUBIN—The House of D'or, D., 2000.....	
SELIG—The Lion Hunter, D., 1000.....	
VITAGRAPH—The Mysterious Mr. Davey.....	

Thursday, December 3, 1914.

BIOGRAPH—In Quest of a Story, 1000.....	
ESSANAY—Sophie's Fatal Wedding, C., 1000.....	
LUBIN—The Grip of the Past, D., 1000.....	
VITAGRAPH—The Man That Might Have Been, D., 1000	
SELIG—Hearst-Selig News Pictorial No. 80, N., 1000..	

Friday, December 4, 1914.

BIOGRAPH—Making Them Cough Up, C., and Bertha, the Buttonhole Maker, Split Reel.....	
EDISON—Who Goes There? C., 2000.....	
ESSANAY—The Place, the Time and the Man, 2000...	
KALEM—The Devil and Mrs. Walker, C., 1000.....	
LUBIN—A Believer in Dreams, C., 1000.....	
SELIG—Which Ham Is Schnappsmeier's, C., and Love's Acid Test, C., Split Reel.....	
VITAGRAPH—The Methods of Margaret, C., 1000....	

Saturday, December 5, 1914.

BIOGRAPH—The Deacon's Son, D., 1000.....	
EDISON—It's a Bear, C., 1000.....	
ESSANAY—Broncho Billy's Judgment, D., 1000.....	
KALEM—The Stolen Engine, D., 1000.....	
LUBIN—Brown's Cook, C., and He Wanted His Pants, C., Split Reel.....	
SELIG—The Woman Always Must Pay, D., 1000.....	
VITAGRAPH—Bunny's Little Brother, C., 1500, and Flowery California, E., 500.....	

RECORD OF CURRENT AND COMING RELEASES — Continued

UNIVERSAL PROGRAM RELEASES OF NEXT WEEK

Monday, November 23, 1914.

IMP—His Gratitude (Mary Pickford Reissue), D., 1000.	4297
VICTOR—Terrence O'Rourke—Gentleman Adventurer —“The Empire of Illusion,” D., 1000.	4298
STERLING—Black Hands, C., 1000.	4300
STRAND—War News No. 11, N., 1000.	4301

Tuesday, November 24, 1914.

UNIVERSAL SPECIAL—The Master Key No. 2, 2000.	4302
GOLD SEAL—The Mysterious Rose, D., 2000.	4304
CRYSTAL—Sammie's Vacation, C., 1000.	4306
NESTOR—As We Journey Through Life, D., 1000.	4307

Wednesday, November 25, 1914.

JOKER—The Tricky Flunkie, C.; La Rochelle, Ed., 1000	4308
ECLAIR—The Heiress and the Crook, D., 2000.	4309
HEPWORTH—Ghosts, C., 1000.	4311

Thursday, November 26, 1914.

ANIMATED WEEKLY—Weekly No. 142, W., 1000.	4312
IMP—Human Hearts, D., 3000.	4313
STERLING—His New Job, C., 1000.	4316
HEPWORTH—Girl from the Sky.	4317

Friday, November 27, 1914.

NESTOR—In Taxi No. 23, C., 1000.	4318
POWERS—Sissy Dobbins, Oil Magnate, C. D., 1000.	4319
VICTOR—The Heart of Night Wind, D., 2000.	4320

Saturday, November 28, 1914.

JOKER—He Married Her Anyhow, C.; Eccentric Comiques, Ed., 1000.	4322
FRONTIER—The Best Man, 1000.	4323
101 BISON—The Brand of His Tribe, W. D., 2000.	4324

Sunday, November 29, 1914.

REX—Lights and Shadows, D., 2000.	4326
L-KO—The Blighted Spaniard, C., 1000.	4328
ECLAIR—The Ghost of the Mine, D., 1000.	4329

RELEASES OF THE WEEK AFTER

Monday, November 30, 1914.

IMP—The Coward, D., 2000.	
STERLING—Love, Luck and Candy, C., 1000.	
VICTOR—Mary Fuller in “A Lonely Salvation,” D., 1000	

Tuesday, December 1, 1914.

CRYSTAL—Charlie Woos Vivian, and The Barber Shop Fued. Split Reel.	
GOLD SEAL—Called Back, D., 4000.	

Wednesday, December 2, 1914.

ANIMATED WEEKLY—Weekly No. 143, N., 1000.	
ECLAIR—The Girl Stage Driver, D., 2000.	
JOKER—The Wise Guys, C., 1000.	

Thursday, December 3, 1914.

IMP—The Philanthropist, D., 1000.	
REX—The Mystery of the Sea View Hotel, D., 1000.	
STERLING—Snitz's Wedding Day, C., 1000.	

Friday, December 4, 1914.

NESTOR COMEDY—When Lizzie Gets Her Shine, C., 1000	
POWERS—The Heart of a Magdalene, D., 1000.	
VICTOR—Father Buys a Bale, C., 1000.	

Saturday, December 5, 1914.

101 BISON—The Foundlings of Father Time, D., 2000.	
FRONTIER—The Circle of Gold, D., 1000.	
JOKER—A Dream of a Painting, C., and Educational, Split Reel	

Sunday, December 6, 1914.

ECLAIR—The Higher Impulse, D., 1000.	
L-KO—Fido's Dramatic Career, C., 1000.	
REX—The Lion, the Lamb and the Man, D., 1000.	

MUTUAL PROGRAM RELEASES OF NEXT WEEK

Monday, November 23, 1914.

AMERICAN—In the Candle Light, D., 2000.	02632
KEYSTONE—His Taking Ways.	02635
RELIANCE—Our Mutual Girl No. 45, 1000.	02634
KEYSTONE SPECIAL—The Sea Nymphs, 2,000.	

Tuesday, November 24, 1914.

BEAUTY—As a Man Thinketh, D., 1000.	02640
MAJESTIC—Another Chance, 1000.	02639
THANHOUSER—Mrs. Van Ruyter's Stratagem, 2000.	02637

Wednesday, November 25, 1914.

AMERICAN—The Archaeologist, D., 1000.	02644
BRONCHO—The Cross in the Desert, 2000.	02642
RELIANCE—They Never Knew, 1000.	02645

Thursday, November 26, 1914.

DOMINO—The Mills of the Gods, 2000.	02647
KEYSTONE—A Halted Career.	02649
MUTUAL WEEKLY—No. 100, 1000.	02650

Friday, November 27, 1914.

KAY BEE—A Crook's Sweetheart, 2000.	02652
RELIANCE—The Hop Smugglers, 1000.	02655
PRINCESS—The Wild Woolly West, C., 1000.	02654

Saturday, November 28, 1914.

KEYSTONE—Title Not Yet Announced.	02658
RELIANCE—The Kaffir's Skull, 2000.	02657
ROYAL—Before and After.	02659

Sunday, November 29, 1914.

KOMIC—A Corner in Hats.	02662
MAJESTIC—The Sisters, D., 2000.	02660
THANHOUSER—A Denver Romance	02663

RELEASES OF THE WEEK AFTER

Monday, November 30, 1914.

AMERICAN—The Beggar Child, D., 2000.	
RELIANCE—Our Mutual Girl No. 46, 1000.	
KEYSTONE—Title not announced, C., 1000.	

Tuesday, December 1, 1914.

THANHOUSER—The Centre of the Web, D., 2000.	
MAJESTIC—Old Good for Nothing, D., 1000.	
BEAUTY—Cupid and a Dress Coat, C., 1000.	

Wednesday, December 2, 1914.

BRONCHO—A Romance of Old Holland, D., 2000.	
AMERICAN—The Strength of Ten, D., 1000.	
RELIANCE—The Lucky Shot, D., 1000.	

Thursday, December 3, 1914.

DOMINO—The Vigil, D., 2000.	
KEYSTONE—Title not announced.	
MUTUAL WEEKLY—No. 101, 1000.	

Friday, December 4, 1914.

KAY BEE—Mother of the Shadows, D., 2000.	
PRINCESS—The Creator of Hunger, D., 1000.	
THANHOUSER—Naidra the Dream Woman, D., 1000.	

Saturday, December 5, 1914.

RELIANCE—Who Shot Bud Walton? D., 2000.	
KEYSTONE—Title not announced.	
ROYAL—Sherman Was Right—It's Very Trying.	

Sunday, December 6, 1914.

MAJESTIC—A Question of Courage, D., 2000.	
KOMIC—Mr. Hadley's Uncle (Bill No. 12), C., 1000.	
THANHOUSER—The Amateur Detective, C., 1000.	

What Do You Need?

LISTING IN THE BUYERS' GUIDE, FOR NAME AND ADDRESS, INCLUDING ONE YEAR'S SUBSCRIPTION TO MOTION PICTURE NEWS—\$8.00 A YEAR, CASH IN ADVANCE. FREE TO ADVERTISERS USING \$100.00 OR MORE WORTH OF DISPLAY SPACE DURING THE YEAR. ADDRESS ADVERTISING DEPARTMENT

ADVERTISING NOVELTIES

Philip Hano, 806-810 Greenwich St., New York.

ANNOUNCEMENT SLIDES

Niagara Slide Co., Lockport, N. Y.

ASBESTOS BOOTHS

Sharlow Bros., 442 W. 42nd St., New York.

CLEANING AND RENOVATING FILM

Film Redeveloping Co. of America, 145 W. 45th St., New York.

Multicolor Film Improving Co., Inc., 15 E. 26th St., New York.

COSTUMERS

Miller-Costumier, 236 South 11th St., Philadelphia, Pa.

DEVELOPING TANKS

A. J. Corcoran, Inc., 9½ John St., New York.

ELECTRIC LIGHTING SETS

The Chas. A. Strelinger Co., Box P-2, Detroit, Mich.

FILMS

(Manufacturers, Dealers and Renters)

American Film Mfg. Co., Chicago, Ill.
Thomas A. Edison, Inc., 275 Lakeside Ave., Orange, N. J.
Essanay Film Mfg. Co., First National Bank Bldg., Chicago, Ill.

General Film Co., 200 Fifth Ave., New York.

George Kleine, 166 N. State St., Chicago, Ill.

Lubin Mfg. Co., Philadelphia, Pa.

G. Melies, 204 E. 38th St., New York.

Mutual Film Corp., 71 W. 23rd St., New York.

New York Motion Picture Corp., Longacre Bldg., New York.

Pathé Freres, 1 Congress St., Jersey City, N. J.

Renfax Film Co., Inc., 110 W. 40th St., N. Y.

Selig Polyscope Co., Chicago, Ill.

The Balboa Amusement Producing Co., Long Beach, Cal.

Thanouser Film Corp., New Rochelle, N. Y.

Universal Film Mfg. Co., 1600 Broadway, N. Y.

FILM ACCESSORIES

Berlin Aniline Works, 213 Water St., New York.

FILM TITLES, PRINTING, DEVELOPING, ETC.

Commercial Motion Pictures Co., Inc., 220 W. 42nd St., New York.

Centaur Film Co., 670-682 Ave. E, Bayonne, N. J.

Evans Film Mfg. Co., 412-22 W. 216th St., at Broadway, New York.

Gunby Bros., Inc., 145 W. 45th St., New York.

Industrial Moving Picture Co., 223-233 W. Erie St., Chicago.

Standard Motion Picture Co., 5 S. Wabash Ave., Chicago.

Standard Filmprint Corp., 120 School St., Yonkers, N. Y.

FILM REELS

Lang Mfg. Works, Olean, N. Y.

Taylor-Shantz Company, 224 Mill St., Rochester, N. Y.

FURNITURE AND FURNISHING ON RENTAL

William Birns, 103-105 West 37th St., New York.

FEATURE FILMS

Alco Film Corp., 218 W. 42d St., New York.

Alliance Films Corp., 126 W. 46th St., New York.

Albuquerque Film Mfg. Co., Inc., 406 Court St., Los Angeles, Calif.

All Star Feature Corp., 220 W. 42d St., New York.

Amrosio American Co., 15 E. 26th St., New York.

Bosworth, Inc., 640 N. Olive St., Los Angeles, Cal.

Box Office Attraction Film Rental Co., 130 W. 46th St., New York.

Blinkhorn Photoplays Corp., 110 W. 40th St., N. Y.

California Motion Picture Corp., San Francisco, Cal.

Cosmofotofilm Co., 110 W. 40th St., New York.

Cosmos Feature Film Corp., 126-130 W. 46th St., New York City.

Direct-From-Broadway Features Co., 46 W. 24th St., New York.

Eclair Film Co., 126 W. 46th St., New York.

Eclectic Film Co., 110 W. 40th St., New York.

Excelsior Feature Film Corp., Inc., 110 W. 40th St., New York.

G. W. Feature Film Corp., 145 W. 45th St., N. Y.

Features Ideal, 126 W. 46th St., New York.

Famous Players Film Co., 213-229 W. 26th St., New York.

Films Lloyds, Inc., 220 W. 42nd St., New York.

General Film Co., 200 Fifth Ave., New York.

General Feature Film Co., 313 Mallers Bldg., Chicago, Ill.

Gaumont Co., 110 W. 40th St., New York.

Greene's Feature Photo Plays, Inc., 110 W. 40th St., New York.

W. W. Hodkinson, 110 W. 40th St., New York.

Imperial Motion Picture Co. of N. Y., Inc., 1476 Broadway, New York.

Inter-Continent Film Co., 110 W. 40th St., N. Y.

George Kleine Attractions, 166 N. State St., Chicago, Ill.

New York Office: 1476 Broadway.

Jesse L. Lasky Feature Play Co., Longacre Theatre, New York.

Life Photo Film Corp., 220 W. 42nd St., N. Y.

Mecca Feature Film Co., Inc., 126 W. 46th St., New York.

Mohawk Film Co., Times Bldg., New York.

Oz Film Mfg. Co., Santa Monica Blvd., Los Angeles, Cal.

Paramount Pictures Corp., 110 W. 40th St., N. Y.

Phoenix Feature Film Corp., 129-131 Columbus Ave., Boston, Mass.

Photo Play Production Co., 220 W. 42nd St., N. Y.

Picture Playhouse Film Co., 110 W. 40th St., New York.

Playgoers Film Co., Lyric Theatre, New York.

Popular Plays and Players Co., 1600 Broadway, New York.

Progress Film Co., 110 W. 40th St., New York.

Progressive Motion Pictures Corp., Times Bldg., New York.

Ramo Films, Inc., Columbia Theatre Bldg., N. Y.

Rolands Feature Film Co., 145 W. 45th St., N. Y.

A. H. Sawyer, Inc., 1600 Broadway, New York.

Select Photo Play Producing Co., Inc., 71 W. 23rd St., New York.

Sterling Camera & Film Co., 145 W. 45th St., New York.

Solax Co., Fort Lee, N. J.

The Masterpiece Film Mfg. Co., 1111 Van Nuys Bldg., Los Angeles, Cal.

The Balboa Amusement Producing Co., Long Beach, Cal.

The Photoplay Productions Releasing Co., 37 S. Wabash Ave., Chicago, Ill.

Union Features, 126 W. 46th St., New York.

Universal Film Mfg. Co., 1600 Broadway, N. Y.

University Films, Inc., 110 W. 40th St., N. Y.

Edw. H. Wagner, Agt., Dania Biofilm Co., 38 Park Place, New York.

World Film Corporation, 130 W. 46th St., N. Y.

Warner's Features, Inc., 130 W. 46th St., N. Y.

LANTERN SLIDE MATS AND REEL BANDS

Lantern Slide Mat Co., 149 W. 35th St., N. Y.

LABELS

Every Ready Roll Label Co., 203-7 W. 40th St., New York City.

LIGHTING PLANTS

Cushman Motor Works, Lincoln, Neb.

LOBBY PHOTOS

The Wyanoak Pub. Co., 136 W. 52nd St., N. Y.

MOTION PICTURE MACHINES AND SUPPLIES

Amusement Supply Co., 160 E. North Fifth Ave., Chicago, Ill.

Behrend Motion Picture Supply House, 440 Fourth Ave., New York.

Calehuff Supply Co., 1301 Race St., Philadelphia, Pa.

Enterprise Optical Co., 568 W. Randolph St., Chicago, Ill.

Lears Theatre Supply Co., Sam Lears, Prop., 509 Chestnut St., St. Louis, Mo.

Oliver Moving Picture Supply Co., 647 Euclid Ave., Cleveland, O.

Picture Theatre Equipment Co., 21 E. 14th St., New York.

Precision Machine Co., 317 E. 34th St., N. Y.

Nicholas Power Co., 90 Gold St., New York.

The Phantascope Mfg. Co., Washington, D. C.

Sweeley's Photo Supply House, 514-516 Eric Ave., Renova, Pa.

Williams, Brown & Earle, Inc., 916-918 Chestnut St., Philadelphia, Pa.

MOTION PICTURE APPARATUS

Burke & James, Inc., 240-258 E. Ontario St., Chicago, Ill.

MUSICAL INSTRUMENTS

American Photo Player Co., 62 W. 45th St., N. Y.

Rudolph Wurlitzer Co., Cincinnati, O.

OPERA CHAIRS

The Hardesty Mfg. Co., Canal Dover, Ohio.

Steel Furniture Co., Grand Rapids, Mich.

POSTER AND PICTURE FRAMES

Menger & Ring, 442 W. 42nd St., New York.

Newman Mfg. Co., 717 Sycamore St., Cincinnati, O.

PIPE ORGANS

Henry Pilcher's Sons, 914-920 Mason Ave., Louisville, Ky.

M. P. Moller, Hagerstown, Md.

PROJECTION LENSES

Bausch & Lomb Optical Co., 569 St. Paul St., Rochester, N. Y.

POSTERS

The Morgan Lithograph Co., Cleveland, Ohio.

RAW FILM

Eastman Kodak Co., Rochester, N. Y.

Celluloses Planchon, Inc., 75 Fifth Ave., N. Y.

David Horsley, 1600 Broadway, New York.

Raw Film Supply Co., 15 E. 26th St., New York.

REWINDERS AND GENERAL SUPPLIES

L. C. Smith Co., Schenectady, N. Y.

SCREENS

Atsco, Inc., 218 West 42nd St., New York.

Day & Night Screens, Inc., 110 W. 40th St., N. Y.

Mirror Screen Co., Inc., Shelbyville, Ind.

STEEL FILM EQUIPMENT FOR EXCHANGES AND MFERS.

Columbia Metal Box Co., 226-228 E. 144th St., New York.

TICKETS—ROLL AND COUPON

Rees Ticket Co., 400 S. 10th St., Omaha, Neb.

THEATRE LOBBY FRAMES AND FIXTURES

Newman Mfg. Co., 715 Sycamore St., Cincinnati, O.

UNIFORMS

Fechheimer Bros., Union-made Uniforms, Cincinnati, O.

VENTILATION, COOLING AND HEATING

Typoon Fan Co., 1544 Broadway, New York.

RELEASE DATES FOR READY REFERENCE

GENERAL FILM PROGRAM

BIOGRAPH

11-19.	A Fowl Deed, C.	528
11-20.	The Girl and the Miser, D.	1000
11-21.	Blacksmith Ben, D.	999
11-23.	All on Account of the Cheese, C.	305
	Thrown Off the Throne, C.	693
11-24.	The Romance of a Poor Young Man, D.	2023
11-26.	The Way Back, D.	998
11-27.	His Old Pal's Sacrifice, D.	1000
11-28.	Little Miss Make-Believe, D.	1000
11-30.	A Mother's Way, D.	1000
12-1.	The Closing Web, D.	1000
12-3.	In Quest of a Story, D.	1000
12-4.	Making Him Cough Up, C.	1000
	Bertha, the Buttonhole-Maker.	
12-5.	The Deacon's Son, D.	1000

COLUMBUS

10-27.	Mulligan's Ghost, C.	1000
11-3.	A Twisted Affair, C.	1000
11-10.	A Family Intermingle, C.	500
	Oh! What a Dream, C.	500

EDISON

11-3.	Shorty, D.	1000
11-4.	Jenks and the Janitor, C.	500
	Buster Brown, C.	500
11-7.	Getting to the Ball Game, C.	1000
11-9.	With Slight Variations, C.	1000
11-10.	The Heritage of Hamilton Cleek, D.	1000
11-13.	A Question of Identity, D.	2000
11-14.	The Everlasting Triangle, D.	1000
11-16.	The Adventures of the Lost Wife, C.	1000
1-17.	A Moment of Madness, D.	1000
11-18.	Buster Brown and the German Band, Cart.	400
	A Millinery Mix-up, C.	600
11-20.	What Could She Do? D.	3000
11-21.	Dickson's Diamonds, D.	1000
11-23.	His Chorus Girl Wife, D.	1000
11-24.	A Gypsy Madcap, D.	1000
11-25.	The Temple of Moloch, D.	1000
11-27.	The King's Move in the City, D.	2000
11-28.	The Last of the Hargroves, D.	1000
11-30.	Wood B. Wedd Goes Snipe, C.	1000
12-1.	The Girl of the Open Road.	
12-2.	A Double Elopement, C.	1000
12-4.	Who Goes There? C.	2000
12-5.	It's a Bear, C.	1000

ESSANAY

11-17.	The Servant Question, C.	1000
11-18.	Proving That Spongers Are Found in a Drug Store, C.	1000
11-19.	A Horse on Sophie, C.	1000
11-21.	Proncho Billy's Scheme, D.	1000
11-23.	Sweetie at the Fair, C.	1000
11-24.	Beyond Youth's Paradise, D.	1000
11-25.	The Fable of Aggie and the Aggravated Attacks, C.	1000
11-26.	Snakeville's Reform Wave, C.	1000
11-27.	Scars of Possession, D.	2000
11-28.	Proncho Billy's Double Escape, D.	1000
12-1.	The Buffer, D.	1000
12-2.	The Fable of "The Club Girls and the Four Times Veteran," C.	1000
12-3.	Sophie's Fatal Wedding, C.	1000
12-4.	The Time, the Place and the Man.	2000
12-5.	Proncho Billy's Judgment, D.	1000

KALEM

11-6.	The Indian Suffragettes, C.	
11-7.	The Man in the Vault, D.	
11-9.	The Riddle of the Green Umbrella, D.	
11-10.	The Widow's Might, C.	
11-11.	A Midnight Tragedy, D.	2000
11-13.	Ham, the Piano Mover, C.	
11-14.	Helen's Sacrifice, D.	
11-16.	The Man of Iron, D.	2000
11-17.	The Peach at the Beach, C.	
11-18.	His Nemesis, D.	
11-21.	The Plot at the R. R. Cut, D.	
11-23.	The Theft of the Crown Jewels, D.	
11-24.	Tough Luck Smith, C.	
11-25.	The Girl and the Explorer, C.	2000
11-27.	Ham the Iceman, C.	
11-28.	The Girl at the Throttle, D.	
12-30.	Her Bitter Lesson, D.	2000
12-1.	Bud, Bill and the Waiter, C.	1000
12-2.	The Prodigal, D.	2000

12-4.	The Devil and Mrs. Walker, C.	1000
12-5.	The Stolen Engine, D.	1009

KLEINE

9-29.	A Shot from Ambush, D.	2000
10-6.	The Wrecked Special, D.	2000
10-13.	On the Battle Line, D.	2000

LUBIN

11-18.	The Marriage Wager, D.	2000
11-19.	On Suspicion, D.	2000
11-20.	The Unknown County, D.	1000
11-21.	The Tale of a Coat, C.	400
	The Daddy of Them All, C.	600
11-23.	The Beloved Adventurer, No. 11, D.	1000
11-24.	Mother's Baby Boy, C.	400
	He Wanted Chicken, C.	600
11-25.	The Making of Him, D.	2000
11-25.	Was His Decision Right? D.	2000
11-26.	He Waits Forever, D.	1000
11-27.	You Can't Beat Them, C.	400
	The Servant Girl's Legacy, C.	600
11-30.	The Beloved Adventurer, Series No. 12, D.	1000
12-1.	Coupon Collectors, C.	400
	For a Widow's Love, C.	600
12-2.	The House of D'Or, D.	2000
12-3.	The Grip of the Past, D.	2000
12-4.	A Believer in Dreams, D.	1000
12-5.	Brown's Cook, C.	600
	He Wanted His Pants, C.	600
12-7.	The Beloved Adventurer, Series No. 13, D.	1000
12-8.	He Made His Mark, C.	400
	Dob's at the Shore, C.	600
12-9.	A Recent Confederate Victory, D.	2000
12-10.	The Man From the Sea, D.	2000
12-11.	On Moonshine Mountain, D.	1000
12-12.	Sam and the Bully, C.	400
	The Fresh Air Cure, C.	600

RELEASE DAYS

GENERAL FILM PROGRAM

Monday	—Biograph, Edison, Essanay, Hearst-Selig News Pictorial, Kalem, Selig, Vitagraph.
Tuesday	—Biograph, Columbus, Edison, Essanay, Geo. Kleine, Lubin, Selig, Vitagraph.
Wednesday	—Edison, Essanay, Kalem, Lubin, Selig, Vitagraph.
Thursday	—Biograph, Essanay, Hearst-Selig News Pictorial, Lubin, Selig, Vitagraph.
Friday	—Biograph, Edison, Essanay, Kalem, Selig, Lubin, Vitagraph.
Saturday	—Biograph, Edison, Essanay, Kalem, Lubin, Vitagraph, Selig.

UNIVERSAL PROGRAM

Monday	—Victor, Imp, Powers.
Tuesday	—Gold Seal, Crystal, Nestor.
Wednesday	—Nestor, Joker, Eclair.
Thursday	—Imp, Rex, Frontier, Sterling, Animated Weekly.
Friday	—Nestor, Powers, Victor.
Saturday	—Joker, Frontier, 101 Bison.
Sunday	—Rex, Crystal, Eclair, L-KO.
Monday	—American, Keystone, Reliance.
Tuesday	—Beauty, Majestic, Thanhouser.
Wednesday	—American, Broncho, Reliance.
Thursday	—Domino, Keystone, Mutual Weekly.
Friday	—Kay-Bee, Majestic, Princess.
Saturday	—Keystone, Reliance, Royal.
Sunday	—Majestic, Komic, Thanhouser.

MINA

11-16.	The Thrilling Adventures of Count Verace, C.	1000
--------	--	------

SELIG

11-21.	Her Sacrifice, D.	1000
11-23.	Out of Petticoat Lane, D.	1000
	Doc Yak Plays Golf, C.	500
11-23.	Hearst-Selig News Pictorial, N.	1000
11-24.	The Scapegoat, D.	1000
11-25.	The Butterfly's Wings, D.	1000
11-26.	Hearst-Selig News Pictorial, N.	1000
11-27.	A Surprise Party, C.	1000
11-28.	The Fates and Ryan, D.	1000
11-30.	Unrest, D.	1000
12-1.	The Rival Stage Line, C.	1000

12-2.	The Lion Hunter, D.	1000
12-4.	Which Ham Is Schnappmier's? C.	1000
	Lover's Acid Test, C.	1000
12-5.	Her Sister, D.	1000
12-7.	The Mystery of the Seven Chests, D.	2000
12-8.	Saved by a Watch, D.	1000
12-9.	The Abyss	1000
12-11.	One Kiss	1000
12-12.	The Soul Mate.	1000
12-14.	The Lure of the Windigo.	2000
12-15.	The Man From the East.	1025
12-16.	The Test	1000
12-18.	The Tail of a Coat.	850
12-19.	One Traveler Returns.	1000

VITAGRAPH

11-9.	Miss Tomboy and Freckles, C.	1000
11-10.	The Senator's Brother, D.	2000
11-11.	In Bridal Attire, C.	1000
11-12.	Lola, the Rat, D.	1000
11-13.	The Rocky Road of Love, C.	1000
11-14.	Ann, the Blacksmith, D.	1362
	Making of a Newspaper, E.	638
11-16.	Sisters, D.	1000
11-17.	Hope Foster's Mother, D.	2000
11-18.	Fixing Their Dads, C.	1000
11-19.	Too Much Burglar, C.	1000
11-20.	The Professional Scapegoat, C.	1000
11-21.	Mary Jane Entertains, C.	2000
11-23.	The Level, D.	1000
11-24.	The Old Flute Player, D.	2000
11-25.	Netty or Letty, C.	1000
11-26.	Cause for Thanksgiving, C.	1000
11-27.	The Curing of Myra May, C.	1000
11-28.	Convict, Costumes and Confusion, C.	2000
11-30.	Everything Against Him, D.	1000
12-1.	Saved From a Life of Crime, D.	2000
12-2.	The Mysterious Mr. Davey, D.	1000
12-3.	The Man That Might Have Been, D.	1000
12-4.	The Methods of Margaret, C.	1000
12-5.	Bunny's Little Brother, C.	500
	Flowery California, E.	500

UNIVERSAL PROGRAM

ANIMATED WEEKLY

11-18.	Weekly No. 141, N.	
11-25.	Weekly No. 142, N.	1000
12-2.	Weekly No. 143, N.	1000

101 BISON

11-28.	The Brand of His Tribe, D.	1000
12-5.	Foundlings of Father Time, D.	2000
12-6.	The Foundlings of Father Time, D.	2000

CRYSTAL

11-10.	The Life Saver, C.	
11-17.	Oh! You Mummy, and Naughty Nellie, split reel.	
11-24.	Sammie's Vacation, C.	1000
12-1.	Charlie Woos Vivian, and The Barber Shop Feud; split reel.	

ECLAIR

11-15.	Her Own House, D.	
11-18.	The Wondrous Melody, D.	2000
11-22.	A Friend in Need, and Our Beloved Country; split reel.	
11-25.	The Heiress and the Crook.	2000
11-29.	The Ghost of the Mine, D.	1000
12-2.	For the Mastery of the World, D.	3000
12-2.	The Girl Stage Driver, D.	2000
12-6.	The Higher Impulse, D.	1000

FRONTIER

10-31.	The Blacksmith's Daughter, D.	
11-7.	The Girl from Texas, D.	
11-14.	The Moccasin Print, D.	
11-21.	A Relic of Olden Days.	
12-5.	The Circle of Gold, D.	1000

GOLD SEAL

11-10.	The Trey of Hearts, No. 15, D.	3000
11-17.	The Opened Shutters.	4000
11-24.	The Mysterious Rose, My Lady Raffles Series, D.	2000
12-1.	Called Back, D.	4000

ELLA WHEELER WILCOX

*Who wrote the famous
poem on which is
based the powerful
five-part drama*

The Price He Paid



*"For I saw men
everywhere,
Hotfooting the
road of vice;
And women
and preachers
smiled on them
As long as they
paid the price."*

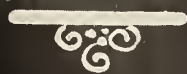

UNITED FILM SERVICE (WARNER'S FEATURES, INC.,) N.Y.

THE PRICE HE PAID

The most gripping drama ever written, based on the famous poem by

Ella Wheeler Wilcox

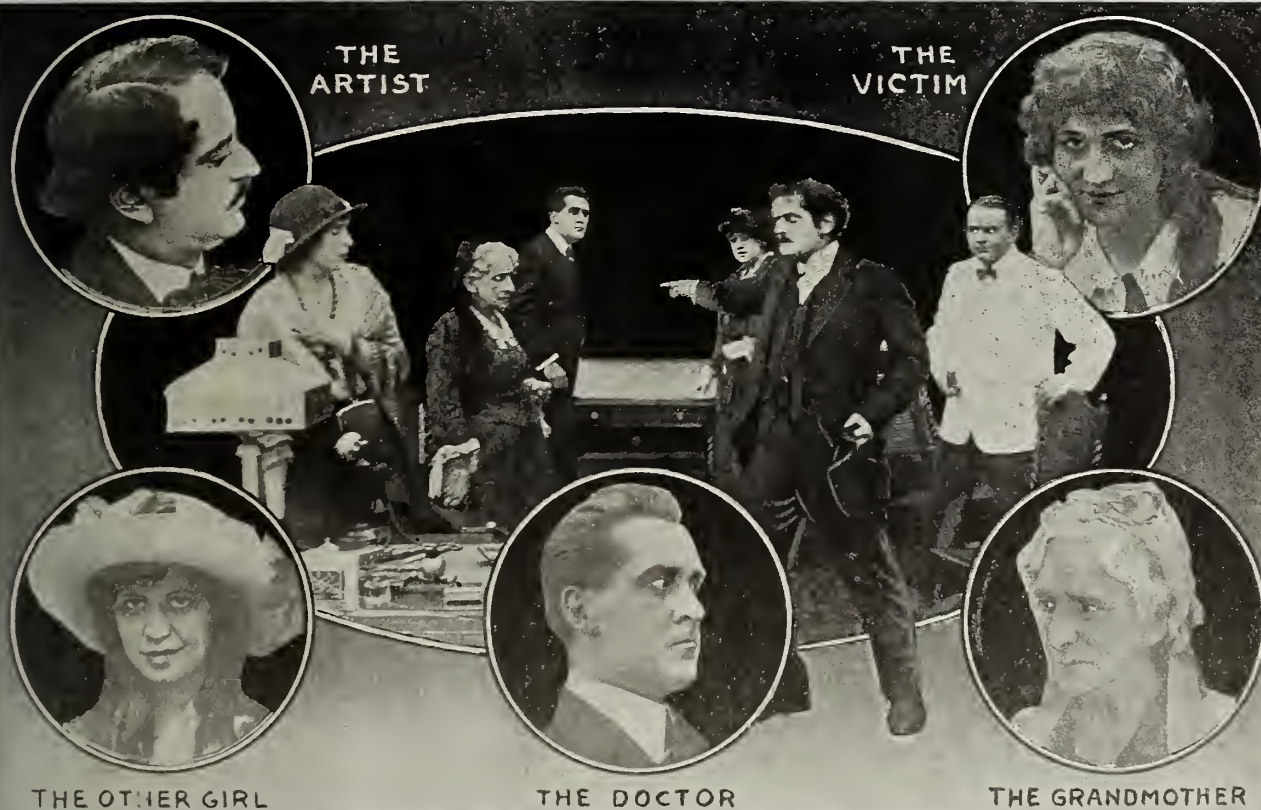

The story this remarkable picture tells is one that touches the heart and stirs the blood. Powerful in its appeal, absorbing in its interest and tremendous in the lesson it teaches, "The Price He Paid" is a fitting tribute to the genius of Ella Wheeler Wilcox and an emphatic credit to the Humanology Film Company, which produced it. The biggest 5-part feature of the year.

UNITED FILM SERVICE (WARNER'S FEATURES, INC.) N.Y.

PAGLIACCI



The first film production *of the* most dramatic masterpiece *of the* operatic stage. "Pagliacci" has brought tears *and* laughter to millions in every corner *of the* world. A beautiful, intensely interesting photo-play, *with* Arthur Maude *and* Constance Crawley *as the* leads.

UNITED FILM SERVICE (WARNER'S FEATURES, INC.,) N.Y.

United Film Service

Releasing the weekly United program
of single-reel comedies and dramas

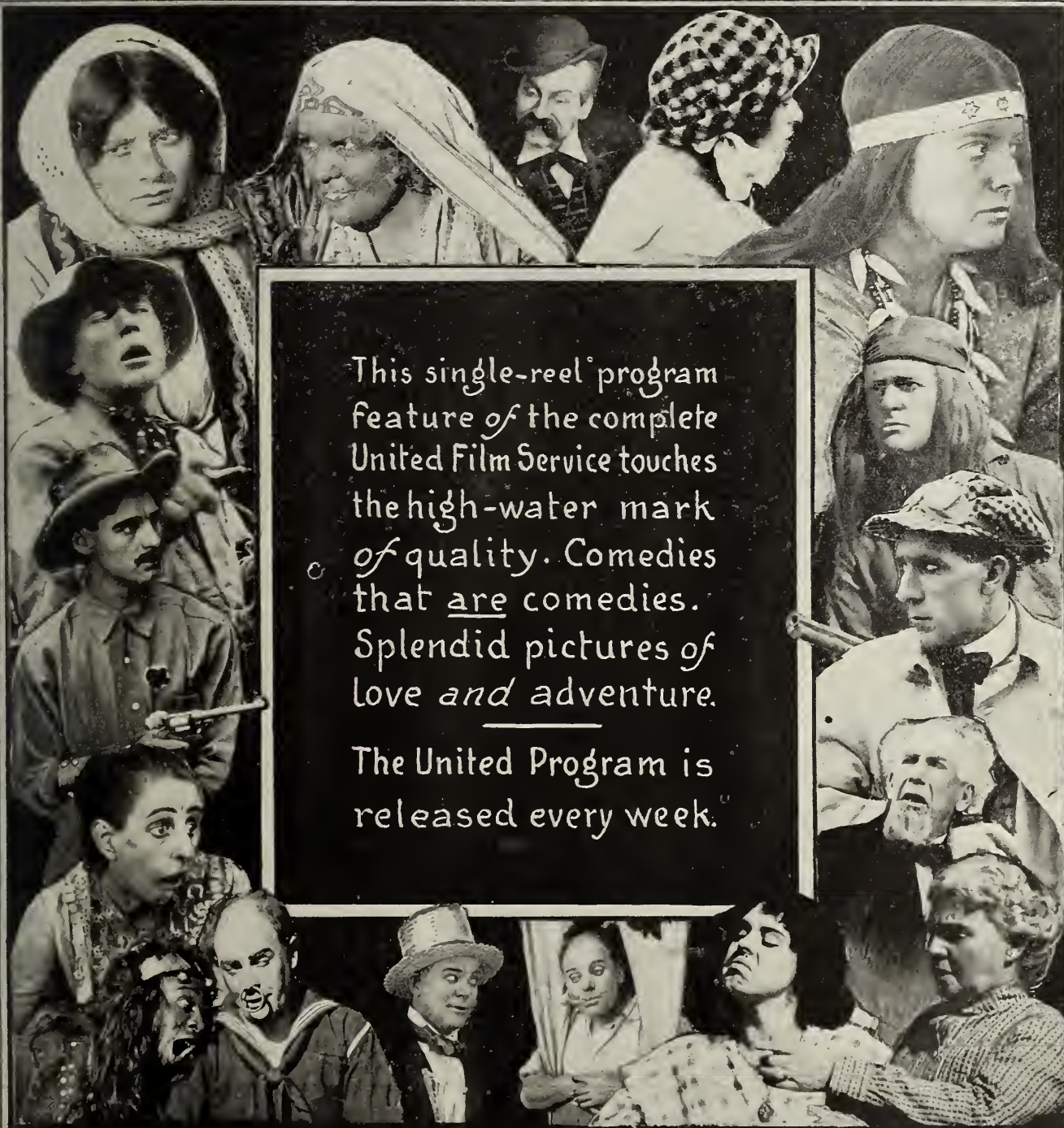

This single-reel program
feature *of* the complete
United Film Service touches
the high-water mark
of quality. Comedies
that are comedies.
Splendid pictures *of*
love *and* adventure.

The United Program is
released every week.

UNITED FILM SERVICE (WARNER'S FEATURES, INC.) N.Y.

Be sure to mention "MOTION PICTURE NEWS" when writing to advertisers.

RELEASE DATES FOR READY REFERENCE — Continued

IMP

11—2.	The Turn of the Tide.....	2000
11—5.	The Universal Boy in "The Mystery of the New York Docks".....	2000
11—9.	The Stronger Love, Mary Pickford Reissue, D.....	2000
11—12.	Peg of the Wilds, D.....	2000
11—16.	The Treasure Train, D.....	2000
11—19.	The Universal Boy in "Cupid and the Fishes".....	2000
11—23.	His Gratitude, Mary Pickford Reissue, D.....	1000
11—26.	Human Hearts, D.....	3000
11—30.	The Coward, D.....	2000
12—3.	The Philanthropist, D.....	1000

JOKER

11—11.	The Frankfurter Salesman's Dream, C.....	
11—14.	Defeat of Father, and Educational, C.....	
11—18.	His Night Out, C.....	
11—21.	The Battle of the Nations, C.....	
11—24.	The Tricky Flunkie, C., and La Rochelle, E., Split Reel.....	
11—28.	He Married Her Anyhow, C., and Eccentric Comiques, E., Split Reel.....	
12—2.	The Wise Guys, C.....	1000
12—5.	A Dream of a Painting, and Educational; split reel.....	

L-KO

11—29.	The Blighted Spaniard, C.....	
12—6.	Fido's Dramatic Career, C.....	1000

NESTOR

10—9.	He Never Said a Word, C.....	
10—16.	The Way of Life, D.....	
10—23.	Cupid Pulls a Tooth, and Mt. St. Bernard, Switzerland; split reel.....	
10—27.	The Wall of Flame, D.....	
11—3.	The Boy Major, D.....	
11—6.	Those Were the Happy Days, C.....	2000
11—10.	The Two Thieves, D.....	
11—13.	When the Girls Were Shanghaied, C.....	
11—20.	When Their Brides Got Mixed, C..... India's Defender of the British Empire, E.....	
11—24.	As We Journey Through Life, D.....	1000

NESTOR COMEDY

12—4.	When Lizzie Got Her Polish, C.....	1000
-------	------------------------------------	------

POWERS

10—30.	The Senator's Lady, D.....	
11—6.	Nan of the Hills, D.....	
11—13.	Sissy Dohins' Oil Magnet, C.....	
11—20.	A Scenario Editor's Dream, C.....	
11—27.	Sissy Dohins, Oil Magnate, D.....	1000
12—4.	The Heart of a Magdalene, D.....	1000

REX

10—29.	White Roses, D.....	
11—1.	The Vagabond, D.....	2000
11—5.	Let Us Have Peace, C.....	2000
11—8.	The Link That Binds, D.....	2000
11—12.	The Shoemaker's Eleventh, C.....	
11—15.	The Chorus Girl's Thanksgiving, D.....	2000
11—19.	His Uncle's Will, D.....	2000
11—22.	Traffic in Bahes, C.....	
11—29.	Lights and Shadows, D.....	2000
12—3.	The Mystery of the Sea View Hotel, D.....	2000
12—6.	The Lion, the Lamh and the Man, D.....	2000

STERLING

11—19.	Dot's Elopement, C.....	
11—23.	Black Hands, C.....	1000
11—26.	His New Job, C.....	1000
11—30.	Love, Luck and Candy, C.....	1000
12—3.	Snitz's Wedding Day, C.....	1000

UNIVERSAL IKE

10—6.	The Neglected Wife.....	
10—13.	Mary Green's Husband, and Educational, C.....	
10—13.	Mary Green's Husband, and The Monkey Cabaret, C., split reel.....	

VICTOR

11—16.	Mary Fuller in "The Phantom Cracksmen," D.....	
11—20.	For the People, D.....	2000
11—23.	Terrence O'Rourke, The Empire of Illusion, D.....	2000
11—27.	Mary Fuller in The Heart of Night Wind, D.....	2000
11—30.	A Lonely Salvation, Mary Fuller, D.....	1000
12—4.	Father Buys a Bale, C.....	1000
12—7.	Terrence O'Rourke—The Inn of the Winged Gods, D.....	2000

MUTUAL FILM PROGRAM

AMERICAN

11—9.	Betty Morse.....	2000
11—11.	The Stolen Masterpiece, D.....	1000
11—16.	Red Bird Wins, D.....	2000
11—18.	Beppo, D.....	1000
11—20.	Old Enough to Be Her Grandpa, C.....	1000
11—23.	In the Candle Light, D.....	2000
11—25.	The Archaeologist, D.....	1000
12—2.	The Strength of Ten, D.....	1000
12—7.	Out of the Darkness, D.....	2000

BEAUTY

11—10.	Motherhood, D.....	1000
11—17.	When Queenie Came Back, C.....	1000
11—24.	As a Man Thinketh, D.....	1000
12—1.	Cupid and a Dress Coat, C.....	1000
12—8.	Limping Into Happiness, C.....	1000

BRONCHO

11—18.	Shorty Falls Into a Title, C.....	2000
11—25.	The Cross in the Desert.....	2000
12—2.	A Romance of Old Holland.....	2000
12—9.	The City of Darkness.....	2000

DOMINO

11—5.	In Old Italy.....	
11—12.	The Friend.....	2000
11—19.	Nipped.....	2000
11—26.	The Mills of the Gods.....	2000
12—3.	The Vigil.....	2000
12—10.	Not of the Flock.....	2000
12—17.	The Flower in the Desert.....	2000

KAY-BEE

10—30.	The Worth of a Life.....	
11—6.	In the Clutches of the Gangster.....	2000
11—13.	The Hateful God.....	2000
11—20.	The Master of the House.....	2000
11—27.	A Crook's Sweetheart.....	2000
12—4.	Mother of the Shadows.....	2000

KEYSTONE

9—24.	The New Janitor, C.....	1000
9—28.	Hard Cider, C.....	1000
10—1.	Killing Horace, C.....	1000
10—3.	Fatty Again, C.....	1000
10—5.	Their Ups and Downs, C.....	1000
10—8.	Hello Mahel, C.....	1000
10—10.	Those Love Pangs, C.....	1000
10—12.	Anglers, C.....	1000
10—15.	High Spots on Broadway, C.....	1000
10—19.	Dash, Love and Splash, and Santa Catalina Islands, split reel.....	
10—22.	Love Siege, C.....	1000
10—24.	Stout Heart but Weak Knees, C.....	1000
10—26.	Shot in the Excitement, C.....	1000
10—26.	Dough and Dynamite, C.....	2000
10—29.	Gentlemen of Nerve, C.....	1000
10—31.	Cursed by His Beauty, C.....	1000
11—2.	Lovers' Post Office, C.....	1000
11—5.	Curses They Remark'd, C.....	1000
11—7.	His Musical Career, C.....	1000
11—9.	His Trysting Places, C.....	2000
11—12.	An Incompetent Hero, C.....	1000
11—14.	How Heroes Are Made, C.....	1000
11—16.	Fatty's Jonah Day, C.....	1000

KOMIC

11—8.	Ethel's Roof Party (No. 10).....	
11—15.	Out Again, In Again.....	
11—22.	Ethel Has a Steady (No. 11).....	
11—29.	A Corner in Hats.....	
12—6.	Bill No. 12.....	
12—13.	The Housebreakers.....	

MAJESTIC

11—3.	False Pride.....	
11—8.	The Tear That Burned.....	2000
11—10.	The Niggard.....	
11—13.	The Folly of Ann.....	
11—15.	The Odalisque.....	2000
11—22.	The Saving Grace.....	2000
11—24.	Another Chance.....	
11—29.	The Sisters.....	2000
12—1.	The Old Good for Nothing.....	
12—6.	A Question of Courage.....	
12—8.	Her Brave Hero.....	
12—11.	Dorothy in the Garret.....	

MUTUAL WEEKLY

11—8.	No. 93.....	
11—15.	No. 94.....	
11—22.	No. 95.....	
10—27.	No. 96.....	
11—3.	No. 97.....	
11—10.	No. 98.....	
11—17.	No. 99, N.....	1000
11—26.	No. 100, N.....	

PRINCESS

10—23.	The Face at the Window.....	
10—30.	The Dead Line.....	
11—6.	When Vice Shuddered.....	
11—13.	Seeds of Jealousy.....	
11—20.	The Bad Mistake.....	
11—27.	The Wild, Woolly West.....	
12—4.	The Creator of Hunger.....	

RELIANCE

11—4.	The Miner's Peril.....	
11—7.	A Woman Scorned.....	
11—9.	Our Mutual Girl No. 43.....	
11—14.	The Floating Call.....	
11—16.	Our Mutual Girl No. 44.....	
11—18.	The Hidden Message.....	
11—21.	His Responsibility.....	2600
11—23.	Our Mutual Girl No. 45.....	
11—25.	They Never Knew.....	
11—27.	The Hop Smugglers.....	
11—28.	The Kaffir's Skull.....	2000
11—30.	Our Mutual Girl No. 46.....	
12—2.	The Lucky Shot.....	
12—5.	Who Shot Bud?.....	
12—7.	Our Mutual Girl, No. 47.....	
12—9.	Forest Thieves.....	
12—12.	On the Ledge.....	

ROYAL

10—31.	Phil's Vacation.....	
11—7.	Max's Money.....	
11—14.	A Fortune in Pants.....	
11—21.	Love Finds a Way.....	
11—28.	Before and After.....	
12—5.	Sherman Was Right—It's Very Trying.....	

THANHOUSER

10—20.	Old Jackson's Girl.....	2000
10—25.	Mr. Cinderella.....	
10—27.	A Madonna of the Poor.....	2000
11—1.	Shep's Race with Death.....	
11—3.	The Turning of the Road.....	
11—8.	Keeping a Husband.....	
11—10.	The Terror of Anger.....	
11—13.	The Chasm.....	
11—15.	The Man with the Hoe.....	
11—17.	Pawns of Fate.....	2000
11—22.	A Messenger of Gladness.....	
11—24.	Mrs. Van Ruyter's Stratagem.....	2000
11—29.	A Denver Romance.....	
12—1.	The Center of the Web.....	2 R.
12—4.	Naidra, the Dream Woman.....	
12—6.	The Amateur Detective.....	
12—8.	The Reader of Minds.....	2 R.
12—13.	When East Meets West.....	
12—15.	The Barrier of Flames.....	2 R.
12—20.	Sid Nee's Finish.....	



DOROTHY DONNELLY



EDMUND BREESE

NOW is the time for all progressive exhibitors to call, wire or write the nearest exchange of *The Box Office Attraction Company* and contract for productions extraordinary.

Artists now appearing for THE BOX OFFICE ATTRACTION COMPANY:

William Farnum
Edmund Breese
Robert Edeson

Wilton Lackaye
Dorothy Donnelly
Charles Richman
Edward Jose

Catherine Countiss
Claire Whitney
Stuart Holmes

Richard Buhler and other Broadway Stars

Here is our imposing array of productions:

Charles Frohman's THE THIEF, by Henri Bernstein
James K. Hackett's THE WALLS OF JERICHO, by Alfred Sutro
Charles Frohman's THE GIRL I LEFT BEHIND ME, by David Belasco
Klaw & Erlanger's A FOOL THERE WAS, by Porter Emerson Browne
Daniel Frohman's THE IDLER, by C. Haddon Chambers
Liebler & Company's THE CHILDREN OF THE GHETTO, by Israel Zangwill
Charles Frohman's SAMSON (not a biblical play), by Henri Bernstein and fifty others in course of preparation



ROBERT EDESON



WILTON LACKAYE

NOW RELEASED

St. Elmo

6 reels by Augusta E. J. Evans

Life's Shop Window

5 reels by Victoria Cross

Box Office Attraction Company

WILLIAM FOX, President

Executive Offices

130 West 46th Street, New York City



CHARLES RICHMAN



WILLIAM FARNUM

NEW YORK CITY, N. Y.—126 W. 46th St. Phone: Bryant 7340.
WASHINGTON, D. C.—434 Ninth St., N. Y. Phone: Main 1426.
BOSTON, MASS.—10-12 Piedmont St. Phone: Oxford 6254.
SYRACUSE, N. Y.—400 Eckel Theatre Bldg. Phone: Warren 119.
PHILADELPHIA, PA.—1333 Vine St. Phone: Walnut 4563.
PITTSBURG, PA.—121 Fourth Ave. Phone: Court 1302.
CLEVELAND, O.—618 Columbia Bldg. Phone: Cuyahoga Central 6260R. Bell: Main 5677.
ST. LOUIS, MO.—3632 Olive St. Phone: Bell: Lindel 795, Kinloch, Delmar 4863.
KANSAS CITY, MO.—928 Main St. Phone: Bell: Main 1008 Home: Main 7253.
DALLAS, TEXAS.—1907 Commerce St. Phone: South Western: Main 2066.
SAN FRANCISCO, CAL.—107 Golden Gate Ave. Phone: 4850 Market.
DENVER, COLO.—Ideal Bldg., 17th and Champa Sts. Phone: Main 5071.
MINNEAPOLIS, MINN.—Jewelers' Exchange Bldg. Phone: North Western Nicollect: 2498.
CHICAGO, ILL.—314 Mallers Bldg., 5 S. Wabash Ave. Phone: Central 1716.
SEATTLE, WASH.—1214 Third Ave. Phone: Elliott 1639.

RELEASE DATES FOR READY REFERENCE — Continued

FEATURE RELEASES

ALCO FILM CORPORATION

ALL STAR

- 10—5. The Nightingale, D.....5 parts
10—19. Shore Acres.....5 parts
The Easiest Way.....

CALIFORNIA MOTION PICTURE CORP.

- 11—2. Salomy Jane.....5 parts
Mrs. Wiggs of the Cabbage Patch..

LIFE PHOTO FILM CORPORATION

- Oct. The Ordeal, D.....5 parts
Dec. Springtime.....

POPULAR PLAYS AND PLAYERS

- 10—12. The Ragged Earl, D.....
10—26. Michael Strogoff, D.....5 parts
11—9. The Tigress.....

B. A. ROLFE PHOTO PRODUCTIONS

- Nov. Rip Van Winkle.....5 parts
The Three of Us.....

TIFFANY MOTION PICTURE CORP.

- Heart of Maryland.....

ALLIANCE FILMS CORPORATION

EXCELSIOR FEATURE FILM CO.

- 11—23. When Fate Leads Trump.....
FAVORITE PLAYERS

FAVORITE PLAYERS

- 11—16. The Man Who Couldn't Lose.....
The Last Chapter.....

PROGRESSIVE MOTION PICTURE CO.

- 11—2. McVeagh of the South Seas, D.....5 parts
SELECT PHOTO-PLAY PRODUCING CO.

SELECT PHOTO-PLAY PRODUCING CO.

- 10—26. At the Old Cross Roads, D.....5 parts
MASTERPIECE FILM COMPANY

MASTERPIECE FILM COMPANY

- 11—9. The Hoosier Schoolmaster.....5 parts
The Truth Wagon.....

BOX OFFICE ATTRACTION CO.

BALBOA

- Oct. Test of Manhood.....3 reels
Oct. Little Sunbeam.....3 reels
Oct. The End of the Bridge.....3 reels
Nov. Little Jack.....3 reels
Nov. Message of the Mind.....3 reels
Nov. The Call of the Heart.....2 reels

NEMO

- Oct. Through the Night to Light.....3 reels
Oct. The Vow.....3 reels
Oct. Through Fire and Water.....2 reels
Oct. Seeds of Jealousy.....3 reels
Nov. Bitter Sweets.....3 reels

WHITE STAR

- Oct. The Judge's Wife.....3 reels
Oct. A Great Secret.....3 reels
Oct. The Bracelet.....3 reels
Nov. The Mask.....2 reels
Nov. To Love and to Hold.....2 reels
Nov. Vengeance of the Flames.....3 reels

BOX OFFICE ATTRACTIONS—Special Features

- 11—9. Life's Shop Window.....
11—19. The Walls of Jericho.....
11—29. The Thief.....

BLINKHORN PHOTOPLAYS

- Nov. Lena Rivers, D.....5 reels
Nov. Jane Eyre, D.....4 reels
Nov. The Witness Invisible, D.....3 reels
Nov. The Aviator Traitor, D.....3 reels

COSMOS FEATURE FILM CORPORATION

- Lena Rivers, D.....5 parts
Hearts and Flowers, D.....5 parts
The Little Girl That He Forgot.....

COSMOFOTOFILM CORPORATION

- Oct. England Expects—, D.....
Nov. For Home and Country.....2 parts
Nov. She Stoops to Conquer.....4 parts
Nov. The Two Columbins and A Christmas Carol.....

- Nov. Called Back.....4 parts
Nov. Beauty and the Barge.....4 parts

ECLECTIC FILM COMPANY

- Nov. Cupid's Pranks, C.....1 part
Nov. The Crown of Richard III, D.....3 parts
Nov. Pathé Daily News, No. 76, N.....1 part
Nov. The Quest of the Sacred Gem, D.....4 parts
Nov. Pathé Daily News, No. 77, N.....1 part
Nov. Perils of Pauline, No. 18, D.....2 parts
Nov. The Police Dog (Bray Cartoon), C.....1 part
Nov. The Friend of Birds, E.....1 part
Nov. The Treador's Oath, D.....3 parts
Nov. Pathé Daily News, No. 78, N.....1 part
Nov. The Fireman and the Girl, D.....3 parts
Nov. Pathé Daily News, No. 79, N.....1 part
Nov. Whiffles Wins the Winsome, C.....675 ft.
Nov. Colombo, Scenis.....300 ft.
Nov. Max and the Fair M.D., C.....1 part
Nov. When Fate Was Kind, D.....3 parts
Nov. Pathé Daily News, No. 80, N.....1 part
Nov. More Than Queen, D.....4 parts
Nov. Pathé Daily News, No. 81, N.....1 part
Nov. Perils of Pauline, No. 19, D.....2 parts
Nov. Jolts of Jealousy, C.....1 part
Nov. Thirty Years of a Gambler's Life, D.....3 parts
Nov. Pathé Daily News, No. 82, N.....1 part
Nov. The Stolen Birthright, D.....3 parts
Nov. Pathé Daily News, No. 83, N.....1 part

E. & W. TRANSFILM BUREAU

- Oct. Modern Warfare, D.....6 parts

KINETOPHOTE CORPORATION

- 10—26. Markia, or The Destruction of Carthage.....5 reels
11—2. Born Again.....5 reels
11—16. The Coming Power.....4 reels
11—23. The Spirit of the Poppy.....6 reels
12—7. The Span of Life.....5 reels
12—21. The Little Jewess.....4 reels

OZ FILM COMPANY

- Oct. Patchwork Girl of Oz.....5 parts
Oct. His Majesty, The Scarecrow of Oz.....5 parts
Nov. The Last Egyptian.....

CONTINENTAL FEATURES

KAY BEE

- The Battle of Gettysburg.....

KEYSTONE

- Zu Zu, the Band Leader.....

MAJESTIC

- Ruy Blas.....

MUTUAL SPECIAL

- Mexican War Pictures.....
Seeing South America with Roosevelt.

NEW MAJESTIC

- Sapho.....

N. Y. MOTION PICTURE

- The Wrath of the Gods.....

R & M

- The Great Leap.....
The Gangsters of New York.....
The Battle of the Sexes.....
The Floor Above.....
The Dishonored Medal.....
The Mountain Rat.....
Home, Sweet Home.....
The Avenging Conscience.....

THANHOUSER

- Moths.....
Robin Hood.....
A Legend of Provence.....
Frou-Frou.....
Joseph In the Land of Egypt.....
Cardinal Richelieu's Ward.....
Dope.....

PARAMOUNT PICTURES

BOSWORTH

- 10—1. Pursuit of the Phantom.....5 parts
10—19. Hypocrites!.....4 parts
11—23. The Country Mouse.....4 parts

FAMOUS PLAYERS

- 10—26. Behind the Scenes.....5 parts
11—9. Man from Mexico.....5 parts
11—30. Mrs. Black Is Back.....
12—21. Step Sisters, D.....5 parts
12—28. The Crucible, D.....5 parts
12—31. The Million, D.....4 parts

JESSE LASKY COMPANY

- 10—22. What's His Name?.....5 parts
11—16. The Rose of the Rancho.....5 parts
11—26. The Man from Home.....5 parts
12—7. Ghostbreaker, D.....5 parts

LASKY-LIEBLER

- 12—24. Cameo Kirby, D.....5 parts

SMALLEYS

- 12—17. False Colors, D.....5 parts

PICTURE PLAYHOUSE FILM COMPANY, INC.

- 11—2. For King and Country.....
11—10. The Last Dance.....
11—18. The Wild Flower.....
11—26. The Black Envelope.....
12—2. Convict 555.....
12—10. Partners.....

UNITED FILM SERVICE

WARNER'S FEATURES, INC.

LUNA

- 11—12. Reuben's Busy Day, C.....1 reel
11—19. Sage Brush Leading Lady, C.....1 reel

MITTENTHAL

- 11—8. The Tenor of a Great City.....3 reels

PREMIER

- 11—14. Gypsy's Warning, D.....1 reel
11—21. Bandit of Devil's Gap, D.....1 reel
The Prospector's Warning.....1 reel

SAVOIA

- 11—8. The Last Chord.....3 reels

STARLIGHT

- 11—10. The Villain Still Pursued Her, C.....1 reel
11—17. Noisy Neighbors, C.....1 reel

WARNER'S FEATURES

- Oct. In the Duke's Power, D.....
Oct. Bess of the Blazing Sea, D.....
Oct. The Adventures of Kitty Cogh, D.....
Oct. False Pride Has a Fall, C.....3 parts
Oct. The Hypnotic Violinist, D.....3 parts
Even Unto Death, D.....
Nov. The Serum of Reason.....4 parts

WORLD FILM CORPORATION

- 10—12. The Man of the Hour.....5 parts
10—19. The Mystery of Edwin Drood.....5 parts
10—26. When Broadway Was a Trail.....5 parts
11—2. Across the Pacific.....5 parts
11—9. The Wishing Ring.....5 parts
11—16. One of Millions.....4 parts
11—23. Lola.....5 parts
11—30. The Dancer and the King.....5 parts
12—7. The Marked Woman.....
12—14. As Ye Sow.....
12—21. The Pit.....5 parts

ANIMATED SONGS

Imperial Motion Picture Co., New York

Latest Releases:

- There's a Lonesome Little Girl in a Lonesome Little Town.
She Was My Dad's First Sweetheart.
Down Where the Old Road Turns.
Push It Along.



Be A Big Man

DON'T confine the limits of your vision to the length of your nose. Don't hug the false idea that you know all there is to know about the motion picture business. Don't be one of those short-sighted nickel-squeezers who condemns everything that doesn't bear his trade-mark. Show yourself to be a man of breadth. Give credit where credit is due.

Great Game of Brains

The motion picture game requires brains—not brains in the crude state that God gave them to you, but brains that sparkle with intelligence, that show signs of training and development. Get down to brass tacks. Be frank, honest and truthful with yourself. Admit that—

Balboa Feature Films

Have invaded the field and forced a lot of old fogies to slip a mournful note into their boastful tune. Balboas have stepped right to the front and on the strength of their merit alone—have carved out permanent places for themselves in the estimation of exhibitors and the hearts of the people.

SURE-FIRE MONEY-GETTERS

Balboas have passed the experimental stage. Their standard of excellence is established and will be maintained. They grow better all the time. So it's up to you—Mr. Exchange Man—to install Balboa guns in your fortifications. Make arrangements to include them in your program. The Balboa Company has a producing capacity of twenty thousand feet of finished negative every six days and is ready to supply you with one or more features each week. Remember St. Elmo, Will O' The Wisp, The Criminal Code, Sacrificial Fires, The Square Triangle, Rose of the Alley and the scores of other Balboas that are making motion picture fans sit up and take notice all over the United States. Get Busy. Write or Wire today.

 THE BALBOA AMUSEMENT PRODUCING CO.

H. M. HORKHEIMER, Pres. and Gen. Mgr.

E. D. HORKHEIMER, Secretary and Treasurer

"THE EDUCATION OF MR. PIPP"

(All Star-Alco—Five Reels)
REVIEWED BY H. S. FULD

IT would seem rather more visionary than practical, on first thought to produce a thoroughly logical and complete story from a set of drawings in such a form as to make a film production. And yet the producers of "The Education of Mr. Pipp" have not only produced such a story, but have picturized it in such a manner as to make it a "better-than-the-average" comedy release.

A picturization by Augustus Thomas of his own play, and based on Charles Dana Gibson's drawings, the film is so complete in its plot and story that one's interest never flags for a moment. With the good clean comedy, catchy and humorous sub-titles, there is a laugh every minute.



"WHERE DID YOU GET THAT MONOCLE?"

The actors of the cast are so good in their respective parts that it would not be fair to single out one or two for special mention. Digby Bell plays the part of Mr. Pipp in so realistic a manner that one is apt to be thinking of "poor John" and "Mr. Henpeck" all through the story.

Kate Jopson is Mrs. Pipp, Ida and Julia Pipp are characterized by Bella Daube and Edna Brun, respectively, Count Charmount is Harry Driscoll, John Willing is played by George Irving, Duc de La Touraine by Stanley Dark, Baron Haussling by H. D. Blakemore, Lady Fitzmaurice and her son Lord Herbert are played by Mona Ryan and Frank Patten; and all are good.

The Pipp family upon the receipt of four million dollars paid by the Steel Trust moves from Pittsburgh to New York and endeavors to break into society.

The mother to further her ambitious designs, engages a bogus French nobleman who proves to be one of a group of three clever crooks. A trip to Europe is decided on and a check for \$75 is given the Frenchman before their departure.

With the aid of his two partners in crime the check is raised to \$75,000 and cashed. Willing, the cashier becomes suspicious and succeeds in getting in communication by cable with Pipp and the check is pronounced a forgery.

The rogues are finally located in Paris, and Pipp and Willing and a detective named Pinkerton brings about their capture with the aid of the French secret police.

Mrs. Pipp, realizing the mistake she has made, begs her husband to take her back to Pittsburgh.

The love affairs of the two daughters and Willing and Lord Herbert are brought to a successful conclusion and everything ends happily.

The photography throughout is clear, and there is no lack of sub-titles. The picture taken altogether should add to the producer's reputation.

HORSLEY BUYS BOSTOCK'S WILD ANIMALS

BY the largest deal of its sort ever recorded in the motion picture business Frank C. Bostock's trained wild animals are coming back to America to appear in motion pictures for David Horsley. The animals are due to arrive November 18 on the Atlantic Trans-

port liner "Minnewaska." While the exact purchase price is not known it may be definitely stated to be in excess of \$100,000.

On arriving in New York the animals will be reshipped to Los Angeles accompanied by M. Tudor and the trainers and handlers. In Los Angeles the animals will be installed in new, large and pretentious quarters now being erected on the grounds occupied by Mr. Horsley's studios where the producing forces of the new Mina comedies will also be located for the winter.

"CALLED BACK"

(Cosmofotofilm—Four Reels)
REVIEWED BY CLIFFORD H. PANGBURN

THIS is an adaptation of Hugh Conway's novel of the same name, and is an extremely satisfactory example of the putting a book on the screen. One important feature which adds much to the realism and general effectiveness of the picture is the fact that the producers have kept to the period in which the author of the novel laid the story.

This is during the time when Garibaldi was able to find support only from hands of secret plotters. The costumes are all correct, while the furniture and the general interior arrangements are all in keeping with the period supposed to be represented.

The excellence of the costumes and settings is sufficient to give the story a good portrayal, but there are other points of importance, which have been well handled. The acting is of an unusually finished nature.

Jane Gail, as Pauline, is effective and convincing, although she has to appear as a partly insane person during a portion of the film. Henry Ainley, as her husband, is equally good, while Charles Rock is an impressive Macari, leader of anarchists.

The exteriors have been selected with a care which results in a number of harmonious effects, and also brings out the strong points of the photography.

The story of "Called Back" is one which is rather involved for a condensed telling, but which is full of interest, and which is brought out with perfect clearness in this version.

Pauline is the niece of Macari, an old Italian, who is well meaning but is interested in what he believes to be the cause of the people in his native land. He uses up the fortune of his niece and nephew for the cause. Fearing that their band will be betrayed to the police if the theft is known one of the men kills the nephew.

His sister sees the crime, and the shock causes her to lose her memory. A blind man who has gotten into the wrong house also walks in while the crime is being committed, but is allowed to go after being drugged because of his blindness. Two years later the blind man is cured, and meets the partly demented girl.

He marries her, and tries to learn of her past. After many complications he gets on the right track, and goes to Siberia, where the girl's uncle is a political prisoner. He gets the whole story from him. On his return his wife has regained her memory, and the murderer meets a just punishment. The young wife and her husband find real happiness.

PIERCE PROPAGANDA BEARS FRUIT

AT least one new motion picture department in a Boston daily newspaper will be the result, it is believed, of a luncheon tendered by Bosworth, Inc., through its special representative, Carl H. Pierce, at the German room of the Hotel Touraine, Boston, Mass., last week, to prominent newspaper, motion picture and theatrical interests.

Mr. McIsaac, of the Boston "American," stated that he was willing to give the industry a motion picture page in his paper, provided he could receive the co-operation of the Boston exchanges. Whereupon Mr. Abrams, president of the Famous Players Film Company of New England, who was present, promised his entire co-operation at once.

Other newspapers, it is believed, will soon follow suit. Among the guests who were invited to be present were: Daniel Frohman, W. E. Green, vice-president Park Theatre Company; Hiram Abrams, president Famous Players Film Company; F. J. McIsaac, Boston "American"; John K. Allen, advertising manager "The Christian Science Monitor"; Charles S. Howard, Boston "Globe"; E. H. Crosby, Boston "Post"; Philip Hale, Boston "Herald"; E. F. Harkins, Boston "Journal"; H. T. Parker, "Transcript"; F. H. Cushman, Boston "Advertiser"; Harry L. Asher and J. A. McConville, of the Famous Players of New England.



A MAMMOTH, SPECTACULAR 5-REEL SELIG SPECIAL

RELEASED MONDAY, NOVEMBER 30

IN THE DAYS OF THE THUNDERING

Written by
GILSON WILLETS

HERD

Featuring **TOM MIX**
and **BESSIE EYTON**

A THRILLING DRAMA OF FRONTIER DAYS

Remarkable and picturesque Western scenes

Majestic mountains and rolling prairies

The biggest herd of buffalo in the world

Seven hundred full-blooded Indians

An army of pioneers and hunters

Hundreds of horses hauling prairie schooners

Indian villages with braves, squaws and papposes

Buffalo hunts by Indians and frontiersmen

Indian massacre of a complete wagon train

Thrilling rescue of whites by buffalo hunters

Daring riding by **TOM MIX** and **BESSIE EYTON**

Five Reels of Historically Correct Action

ORDER FROM SPECIAL FEATURE DEPT., GENERAL FILM CO.

Selig Current Releases for Week of November 30-December 5

UNREST

RELEASED MONDAY, NOVEMBER 30

TWO REELS

A novel and entertaining Selig psychological drama, written by W. E. WING.

A new style of picture play, the characters of which are fittingly portrayed by **BESSIE EYTON** and **THOMAS SANTSCHI**.

Special—In the Days of the Thundering Herd

RELEASED MONDAY, NOVEMBER 30.....FIVE REELS

As described above.

Hearst-Selig News Pictorial No. 79

RELEASED MONDAY, NOVEMBER 30.....ONE REEL

Again ahead of all competitors with latest and most up-to-date European war pictures taken by our camera men on the battlefields.

The Rival Stage Lines

RELEASED TUESDAY, DECEMBER 1.....ONE REEL

One of those unrivalled Selig Western comedies, telling the story of two rivals, who finally lost their sweetheart to a "dark horse." Featuring **TOM MIX** and **GOLDIE COLWELL**.

The Lion Hunter

RELEASED WEDNESDAY, DECEMBER 2.....ONE REEL

A Selig Jungle-Zoo Animal drama, telling a story of love and adventure in South Africa. Featuring the celebrated animal actors, including elephants, lions and other jungle beasts.

Hearst-Selig News Pictorial No. 80

RELEASED THURSDAY, DECEMBER 3.....ONE REEL

First showing in America of current European war-news pictures. Taken by our camera men in besieged cities, on battleships, and other war centers, etc.

Which Ham Is Schnappsmeier's?

RELEASED FRIDAY, DECEMBER 4.....SPLIT REEL

A comical and laughable portrayal of the adventures of two German Americans. On the same reel **LOVE'S ACID TEST**. Another Selig comedy.

Her Sister

RELEASED SATURDAY, DECEMBER 5.....ONE REEL

A high class Selig drama, written by **GILSON WILLETS**. An emotional story telling of the penalty paid by a scoundrel for his duplicity.

RELEASED THROUGH GENERAL FILM CO.

Brilliant 4-color Selig Posters ready for shipment on all releases. Order from your Exchange, or from this office.

THE SELIG POLYSCOPE COMPANY

Executive Offices: 20 East Randolph Street, Chicago, Ill.



18 ALCO FILM SERVICE OFFICES NOW, AND MORE COMING

The ALCO PROGRAM



Beatriz Michelena

A PHOTOPLAY PRODUCTION MUST NOW BE ABOVE THE AVERAGE TO SUCCEED. MANY AN EXCELLENT PICTURE HAS FAILED BECAUSE IT DID NOT HAVE THE PROPER DISTINCTION.

ADD TO A MORE THAN AVERAGE PLAY THE DRAWING POWER OF A BIG STAGE STAR AND IT WILL BEGIN TO DRAW WHERE IT SHOULD -- AT THE START.

ADD TO THIS, PROPER HANDLING AND CLASSY ADVERTISING MATTER FOR THE BUSY EXHIBITOR AND YOU HAVE SOME IDEA WHAT ALCO IS DOING.

ALCO IS PUTTING LIFE INTO DEAD HOUSES BY BUYING THE BEST STORIES AND ENGAGING THE MOST FAMOUS STARS, FOR INSTANCE:

MISS BEATRIZ MICHELENA

Who Appears in the Alco Release of November 30 in Anne Flexner Crawford's Dramatization of Alice Hegan Rice's Novels: **MRS. WIGGS OF THE CABBAGE PATCH** and "Lovey Mary"—Miss Michelena Appearing as "Lovey Mary." Produced by the California M. P. Corp'n by Arrangement with Liebler Co.

ALCO FILM CORPORATION

ALCO BUILDING — 218 WEST 42nd STREET — NEW YORK

NOV. 23 THE ALL STAR FEATURE CORPORATION PRESENTS
THE RENOWNED COMEDIAN, DIGBY BELL IN

The EDUCATION of MR. PIPP

A TYPICALLY AMERICAN
COMEDY DRAMA FROM
CHARLES DANA GIBSON'S
FAMOUS PIPP SERIES OF
DRAWINGS. DRAMATIZED
BY AUGUSTUS THOMAS.

IN THIS PICTURE
WE HAVE A GOOD
ILLUSTRATION OF
THE ALCO IDEA. A
FAMOUS STORY BY
A FAMOUS ARTIST,
DRAMATIZED BY
AN ILLUSTRIOUS
AUTHOR, WITH AN
EMINENT ACTOR
BEING STARRED.

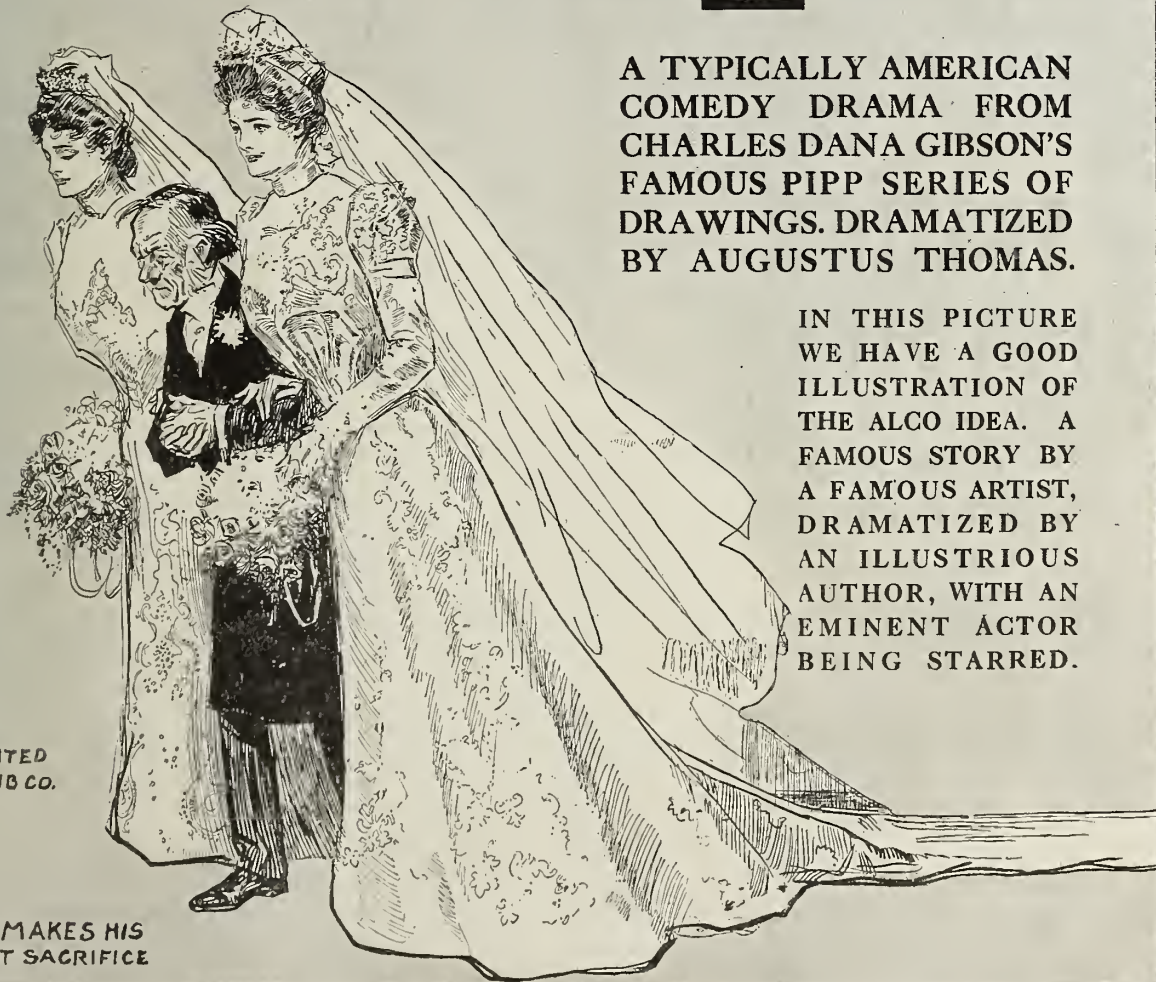

DRAWING
COPYRIGHTED
BY LIFE PUB CO.

MR. PIPP MAKES HIS
GREATEST SACRIFICE

**THE ALBUQUERQUE FILM
MFG. COMPANY, Inc.**

Featuring that clever
Comedienne

Miss Dot Farley

Two Comedies Weekly

RELEASING THROUGH
The United Motion Picture Producers, Inc.
WHO DISTRIBUTE THROUGH
Warner's Features, Inc.

By request from many exchanges
we take pleasure in
reviving the

**FRONTIER
TWIN STORIES**

Written and made famous by Miss Dot
Farley. Under direction of
Gilbert P. Hamilton

Farce Comedy Production
BY

ARCHER McMACKIN

Nuf Sed

WESTERN STUDIO
406 Court St. Los Angeles, Calif.
GILBERT P. HAMILTON, Pres. and Gen. Mgr.

"IN THE DAYS OF THE THUNDERING HERD"

(Selig—Five Reels)

REVIEWED BY T. S. MEAD

COLLIN CAMPBELL has spared no pains nor expense in attempting to produce a wild west drama that will hold the audience's attention through five reels of film. Several quite remarkable features help to make this an interesting and truthful presentation of frontier life in '49.

The largest of the few remaining wild buffalo herds is featured throughout the picture. You see them sleeping, grazing, stampeding, hunted, and killed by both rifle and bow and arrow. There is a regular Indian village with its hundreds of redskins in their original dress, and still maintaining their savage customs. They fight the plainsmen and hunt the buffalo with their bows and arrows, showing a skill with these instruments which has not been dulled by the years of civilization.

Scores of prairie schooners of the kind used in old frontier days and an unlimited supply of horses are unstintingly used in this enormous production. The wild scenery of Pawnee Bill's ranch at Pawnee, Oklahoma, furnishes a particularly good setting for the drama.

There are many realistic fights between the plainsmen and the Indians, and of course, with Tom Mix in the leading role, there is no lack of wonderful horsemanship and breakneck riding. Bessie Eyton makes an attractive heroine, and both Wheeler Oakman and Red Wing play their Indian parts convincingly.

The story is simply a series of the thrilling adventures of Tom Mingle and Sally Madison, who with a band of immigrants attempt a hazardous trip across the plains to the Californian gold fields where Sally's father is awaiting her.

The band is waylaid and wiped out by a strong tribe of Indians. Sally and Tom, the only survivors, are taken prisoner and their lives are spared, because the Indian chief and his sister take a fancy to them. After many adventures they finally manage to escape, and fall in with a band of buffalo hunters, who in turn are almost wiped out by Indians. Help arrives in the nick of time and Sally and Tom at last reach their destination in safety.

STEINER MAY LOCATE ON PACIFIC COAST

"BILL" STEINER, the general manager of the Photo Drama Company, now in Denver, Col., headed for the coast, reports that "After the Ball," featuring Kelcey and Shannon, is being grabbed up all along the line. He has sold several Western States, and opened new offices in many cities, so that bookings will be made more convenient for all exhibitors and save time on deliveries.

The Photo Drama Company have a big surprise in store to be sprung on the trade in the near future. California capitalists are awaiting "Bill's" arrival, and, incidentally, have made arrangements for a large modern studio there.

"Bill" may locate there, while "Jim" Maher will manage the affairs of the company in New York. Pierce Kingsley has been commissioned to look after the selection of the best known stars and film subjects available.

REICHENBACH LEAVES LASKY

HARRY REICHENBACH, advertising and publicity manager of the Jesse L. Lasky Feature Play Company since its beginning last winter, leaves that firm Saturday, November 21, for work in other fields. His plans have not yet been announced.

Novel and effective ideas in advertising and publicity were continually emanating from the Lasky offices during Mr. Reichenbach's tenure of office, as were to be expected from a man of his long experience in both fields. He did much to establish that company's prestige throughout the trade.

H. Whitman Bennett, lately associated with the Mutual and the Shuberts, will be Mr. Reichenbach's successor.

PATHE CAMERAMAN HONORED

General Baumganen, commander of the French troops in Morocco, in a letter to Pathe Freres has highly praised the conduct of their cameraman, who was present during the attack of Taza.

With remarkable coolness the cameraman, M. Pierre Chavarous, while directly in the line of fire, continued to take his pictures with apparently no thought of his own safety. The pictures secured are said to be remarkable.

MINA FILMS

Made in America

One reel comedies are in high popular favor and the demand is growing greater every day.

Yet of all forms of photoplay the short comedy is the most difficult to produce.

MinA Films are the result of careful study and long preparation for this especial work, backed up by years of successful experience in the production of every style of picture.

Not a word was said about the time and money and effort being spent in the perfecting of MinA Films until they had reached the heart-breaking standard set by their producer.

Early in September that high mark had been surpassed and as proof of their extraordinary merit, MinA Films were added to the regular licensed program and, commencing on Thursday, December 17th, the first weekly release will be made through the

GENERAL FILM COMPANY
or other Licensed Exchanges

Place your orders now with the branch office nearest you, or ask for particulars through Melies Mfg. Co., 204 E. 38th St., N. Y.

David Horsley

through careful study and long practical experience has evolved a method and built up an equipment which brings developing, printing, toning, tinting and title work close to perfection.

Several mechanical devices and chemical combinations are Mr. Horsley's own invention. The factory is a model of scientific arrangement, and the prices are right. Only 20 minutes from New York City to the

Centaur Film Co., Bayonne, N. J.

YALE-HARVARD

FOOTBALL GAME

EXCLUSIVE MOTION PICTURES NOT SHOWN IN TOPICAL FILM WEEKLIES

WIRE—PHONE—OR—WRITE E. & W. TRANSFILM BUREAU

110 WEST FORTIETH STREET, NEW YORK

Phone Bryant 4526

FOR BOOKINGS AND TERRITORIAL RIGHTS

THE FOLLOWING THEATRES HAVE ALREADY ARRANGED TO EXHIBIT THIS PICTURE

The Strand Theatre, New York
 B. F. Keith's Palace Theatre, New York
 B. F. Keith's Colonial Theatre, New York
 B. F. Keith's Theatre, Philadelphia
 B. F. Keith's Theatre, Boston
 Poli's Theatres, New England Cities
 Regent Theatre, New York
 Hamilton Theatre, New York
 Claremont Theatre, New York
 Adelphi Theatre, New York

PRODUCED BY THE
COLONIAL MOTION PICTURE CORP.

18 EAST FORTY-FIRST STREET, NEW YORK

RELEASE NOV. 23rd

DIGBY BELL

in

**THE EDUCATION
 OF MR. PIPP**

(5 Parts)

—DECEMBER 28th—

JANE COWL

in

**THE GARDEN OF
 LIES**

All Star Feature Corp.

220 West 42d Street New York

LE COURRIER

Cinematographique

28 Boulevard St. Denis, Paris

Directeur: Charles LE FRAPER

Journal hebdomadaire français, le plus important de l'industrie cinématographique.

Envoie numéro spécimen, sur demande.
 Abonnement 12 FR. 50

"LITTLE JACK"

(Balboa-Box Office—Three Reels)

REVIEWED BY CLIFFORD H. PANGBURN

ANOTHER picture in which Jackie Saunders gives proof of her versatility. The story is one which calls for a wide range of acting. At its opening Miss Saunders is seen as a little country girl, who has been brought up as a boy. She plays the part with great realism, and incidentally runs about barefoot over some country that many actresses would not care to tackle even if fully shod. The unfavorable nature of country does not appear to bother her in the least.

Later Miss Saunders is seen as a young girl living in comfortable surroundings, and still later as a young woman of fashion. She carries off all the parts satisfactorily. Her various impersonations are at all times interesting to watch.

The supporting cast is a strong one. P. E. Peters, who appears opposite Miss Saunders, makes an interesting hero, although it is really the girl who does most of the heroic work.

There is a large number of attractive scenes, among which the closing one is deserving of special mention. It shows the lovers seated on some great boulders at the edge of the sea. The interior scenes are well handled, particularly those showing the offices of the partners in the lumber business.

Little Jack was brought up by her uncle, the leader of a gang of outlaws, and in order to protect her he dresses her as a boy. When Moran, a wealthy lumber dealer, comes to the place for the night she warns him that he will be robbed. Then in fear she runs away.

In the city she falls in with another bunch of thieves who force her to join in robbing an office. She is wounded by the watchman and taken to the hospital. There the lumber dealer discovers that she is the same person who warned him of his danger a few days earlier. He takes her home and her mother cares for her. His partner is cheating him by falsifying the books. Two years later the firm is nearly bankrupt. Little Jack, now an attractive young woman, discovers the partner's crookedness and proves it by a clever ruse. Then she and the honest partner find happiness together.

The picture deserves and will probably attain success.

Be sure to mention "MOTION PICTURE NEWS" when writing to advertisers.

**A Hint Is as Good
 as a Hundred
 Dollars**

if you have sense enough to
 take it and use it in time.

**There Are \$100
 Hints**

in every issue of
MOTION PICTURE NEWS
 Take "Live Wire Exhibitors"
 as an example.

**One Exhibitor
 Added \$300**

to his WEEKLY REVENUE
 with one of the ideas in that
 department.

**BUT—He Was a
 LIVE WIRE:
 ARE YOU?**

Count Your Blessings!

(No. 57. Straight-from-the-Shoulder Talks by Carl Laemmle,
President Universal Film Mfg. Co.)

WE make so many pictures every week that it is simply impossible to do justice to them in our advertising. Week after week we are shoving veritable masterpieces into our regular program **WITH A BARE ANNOUNCEMENT AS TO THEIR TITLE AND RELEASE DATE.**

If any so-called "feature concern" could get its hands on film of such supreme merit it would pack the trade journals with advertising until their covers fairly bulged. It would rent the films out at \$25 to \$50 per day, and plaster the front of the theatres with posters that would cry sensationalism to the high heavens.

But we put them **IN THE REGULAR PROGRAM AND THEY DON'T COST YOU A SINGLE EXTRA CENT!** We save you the \$25 to \$50 that you would have to pay the outside "feature man." This happens not just once in a while, but every week **AND SEVERAL TIMES EVERY WEEK!**

In this way **WE ACTUALLY SAVE YOU MORE THAN YOUR WHOLE FILM SERVICE COSTS.**

Read the last sentence again and let it percolate and percolate and percolate.

Like the old woman who lived in a shoe and had so many children she didn't know what to do, we simply don't know how to tell the story about each great film each and every week. We would be accused of exaggeration. The bare truth about our pictures would sound too good to be true. And we can't find time or space to tell even a tenth part of all the truth about our master productions.

But, as the Scotch writer, McLaurie, puts it, there is "nothing covered that shall not be revealed." The truth about our pictures is revealed to the thousands of exhibitors who use them and to the millions of people who see them. Exhibitors often write to tell us what a wonderful subject this or that one was, and they express surprise that we have not advertised it more liberally.

In other words, no matter how much they expect of us **WE GIVE THEM MORE THAN THEY EXPECT.** This is a mighty healthy basis of operations. Exhibitors who do not use the Universal Program and who, therefore, do not see it regularly have said they thought we drew a long bow in our advertising. But that is merely because they **DO NOT SEE THE UNIVERSAL PROGRAM REGULARLY.** If they did, they would realize that we don't boast half enough about the good things which we crowd into every week's program.

TO UNIVERSAL EXHIBITORS I SAY THIS:—No matter what you are paying for your Universal service you are getting it dirt cheap. You are getting several pictures every week which would cost you \$25 to \$50 a day if we took them off of our regular program and released them as specials or marketed them through

some fake syndicate. You have often paid great big prices for pictures not to be compared with those on our regular weekly program.

The Universal **PUTS ITS OWN NAME ON EVERY PICTURE IT RELEASES.** It has never organized subsidiary companies in order to release pictures at higher prices than our regular customers are paying. We have **ALWAYS PROTECTED UNIVERSAL EXHIBITORS IN THIS AND EVERY OTHER RESPECT.** And we intend to protect them always.

We could have sold state rights on dozens of our two and three-reel features, and we could have made a lot of quick money doing it. But these pictures would have gone into direct competition with the exhibitors who are giving us their **REGULAR SUPPORT.** So, in every instance, we have given Universal exhibitors first crack at all of our masterpieces.

Even now, when we intend to release our next serial, "The Master Key," as a special we are doing it **THROUGH THE REGULAR UNIVERSAL EXCHANGES,** and they in turn are going to give Universal exhibitors the preference in booking it. The exchanges will charge extra money for "The Master Key." They will have to. We are charging them the highest record price for it, and they'll have to make you share the extra cost. That's one of the many reasons why I have been urging you to **INCREASE YOUR PRICE OF ADMISSION** so you can shift part of the burden on to your patrons.

So, when your exchange man breaks the news to you, remember the dozens of features you've had without paying a cent extra. **COUNT YOUR BLESSINGS.**

CARL LAEMMLE,
President.

UNIVERSAL FILM MFG. CO., 1600 Broadway, N. Y. City



LIONEL BARRYMORE

APPEARS IN

"THE SPAN OF LIFE"

(FIVE PARTS)

Just finished
by the

KINETOPHOTE

Released
December 7th

BOOK NOW FOR ALL TERRITORY

MORE KINETOPHOTE FEATURES NOW READY AND BOOKING

"THE SPIRIT OF THE POPPY"

(Six Parts)

The Greatest Moral Photoplay ever written
Endorsed by Clergy, Physicians and Police Officials

"THE COMING POWER"

(Four Parts)

With Lionel Adams, William Crimmins, Edith
Lucket and Anna Rose.

"MARKIA"

or "The Destruction of Carthage"

The big \$200,000 Ambrosio Production

(Five Parts)

also

"BORN AGAIN"

with Beulah Poynter

HERE ARE OUR EXCHANGES:

American Feature Film Co., 162 Tremont
Street, Boston, Mass. — Maine, New
Hampshire, Vermont, Massachusetts,
Rhode Island and Connecticut—all New
England.

Eastern Booking Offices, 1237 Vine St.,
Philadelphia — Eastern Pennsylvania,
Southern New Jersey, Virginia, Delaware
and District of Columbia.

Eastern Booking Offices (Pittsburgh branch,
432 Wabash Building)—Western Penn-
sylvania and West Virginia.

Eastern Booking Offices (Cleveland branch,
218 Columbus Building)—State of Ohio.

K. C. Booking Co., Inc., (Chicago branch,
Mallers Building, S. E. corner of Mad-
ison and Wabash)—Illinois.

Midwest Feature Film Company, Minne-
apolis, Minn.—Minnesota, Iowa, North
and South Dakota and Wisconsin.

Atlantic Service Co., 508 Rhodes Bldg.,
Atlanta, Ga.—Georgia, Alabama, North

Carolina, South Carolina, Mississippi and
Florida.

California Film Service Corporation, 1149
Mission Street, San Francisco, Cal.
(with branches in Salt Lake City, Utah,
Denver, Seattle, Portland, Ore., and Los
Angeles—California, Oregon, Washing-
ton, New Mexico, Montana, Idaho,
Wyoming, Colorado, Nevada, Arizona
and Utah.

Dallas Film Co., Dallas Texas.—Texas,
Louisiana, Oklahoma and Arkansas.

ALL BOOKING THE EXCLUSIVE PROGRAMME OF

Feature

**K. C.
BOOKING
CO.**

Incorporated

Productions

TELEPHONE: *6072 BRYANT

126-132 WEST 46TH ST., NEW YORK



"HARD TIMES" FLY OUT OF THE WINDOW

When MOTION PICTURE NEWS Comes In By The Mail

Ask any live wire Exhibitor if it's true.

Are you reading ACCESSORY NEWS



ANIMATED

SONGS



NOTHING MECHANICAL

NO PHONOGRAPH RECORDS

MOTION PICTURES THAT MOVE TO THE RHYTHM OF SONG

IMPERIAL MOTION PICTURE CO. OF NEW YORK, Inc., 1476 Broadway



1

(Scene from "Mizpah")

MR.
**NATIONAL
 RIGHT
 BUYER!**

Here Is Your Opportunity!

Such a chance to

**GET IN RIGHT
 AT RIGHT PRICES**

on the Ground Floor to

SELL TERRITORY TO OTHERS

may never occur again!

THRILLING FEATURES

(Three and Four Reelers)

- 1—"MIZPAH" (A Little Cabiria)
- 2—"SAVING THE COLORS" (Present War Drama)
- 3—"THROUGH THE FIRING LINE" (Present War Drama)
- 4—"THE DOCTOR'S CRIME" (Sensational Drama)
- 5—"WIFE OF A THIEF" (Sensational Drama)
- 6—"THE BISHOP'S SILENCE" (Love Drama)

and many others—together or separately!

Write today for particulars to

PAUL CROMELIN

112 W. 40TH ST.

Room 501

NEW YORK



2



3



4



5



6

"Master Key" Opens Door of Success

With the Help of Robert Leonard, a Popular Leading Man, and Ella Hall, Known as "the Little Doll of the Films"

THE Universal Film Manufacturing Company is bending every effort to have its newest serial photoplay, "The Master Key," surpass any previous serial ever attempted by the company. John Fleming Wilson has furnished a story of unusual dramatic qualities; those who have already read this script, say that it outdoes the best of his previous works.

engaged him to play juvenile leads. Then he became leading man for the Otis Turner Company, and assisted Mr. Turner in producing "Swede Larson," "The Little Sister," "The Decision," and many others.

Little Ella Hall, Mr. Leonard's leading lady is sometimes called "The Little Doll of the Films." She is a clever little actress and one of the most ambitious players on

able to show all these people at once, moving in a long column, or weaving to and fro across the stage, or in the full retreat of a defeated army.

It has remained for two men—already upsetters of photoplay tradition and creators of new methods—to pass beyond this stage and to leap into prominence with the—one almost might say effrontery, but perhaps it would be more descriptive to say daring, to put 15,000 human beings in one mob into numerous scenes in a brand new film drama.

As soldiers of the United States Army, as members of the famous Ku Klux Klan, as natives of the city in which the dramatic action takes place, and as the objects of the wrath of all these people, are 12,000 of these actors shown. Three thousand more are negroes, fleeing from the wrath to come as from a scourge. The negroes, hunted by the white rescuers of the Southern states from political domination by the blacks, are seen fleeing before the Ku Klux Klan, and saved only by the regiments of Federal troops sent to their aid.

It is in a film dramatization of "The Clansman," Dr. Dixon's famous story of Reconstruction days, that these huge mobs are seen. And the two men who dared to employ so many people, weld them into a homogeneous mass, and then train them to be capable actors, are D. W. Griffith, the \$100,000-a-year director of the Mutual Film Corporation, and Harry E. Aitken, its president.

Mae Marsh, Blanche Sweet, Dorothy and Lillian Gish carry the burden in "The Clansman" of the women leads. Henry Walthall, Spottiswoode Aiken, and other actors of equal renown, take the leading male roles. Always Griffith did the directing, whether one actor was in a scene or ten thousand, and George Bitzer, one of the best known of motion picture camera men, took the pictures.

It has not been definitely announced just when "The Clansman" will be released. Probably it will be within the next two or three weeks. "The Clansman," according to President Aitken's plans, will be seen first on Broadway.

STARS OF UNIVERSAL'S SERIAL "THE MASTER KEY" AND ITS AUTHOR



ROBERT LEONARD

ELLA HALL

J. FLEMING WILSON

John Fleming Wilson is one of the best writers of fiction of our present day and that Robert Leonard and Ella Hall, the stars who will play the leading roles in the "Master Key," are two of the most popular young stars in screendom is admitted.

Mr. Wilson is too well known for comment on his work. He is noted as a writer of fiction which is unsurpassed for realism. Some of his better known works are: "The Land Claimers Across the Latitude," "The Man Who Came Back" and "Princess of Sorry Valley." In the "Master Key," however, he claims he has accomplished the height of his ambition. By especial arrangements, this story will run in serial form in newspapers in the United States and Canada while weekly episodes of two reel lengths will be shown in the leading theatres.

In selecting Robert Leonard to play John Dore, the young mining engineer and the hero of the play, the Universal has indeed made a happy choice. A six-footer, broad-shouldered with a strong, expressive face, he is ideally fitted to play this role.

Mr. Leonard is vitally interested in his work and realizing what a tremendous opportunity the Universal Company has given him in offering the stellar role in "The Master Key," he has devoted all his spare time to study of his part. He has familiarized himself with every scene, every line of action, every detail of the great story so that he has, at his finger tips, everything necessary for the assured scenes of the play. For weeks, his spare moments were devoted to unearthing secrets of the mining engineering clan.

Starting as a chorus man eight years ago in Los Angeles, Mr. Leonard has managed to work his way to the top. It is a little more than three years ago that the call of the films made itself known to him and soon the Universal Company in California

the screen. Her remarkable versatility is being shown in this serial. Here she is called upon to express every emotion and she attains a height which astounds one. That such a young actress—she is barely eighteen—can play the part of a woman torn between conflicting emotions such as are portrayed in "The Master Key" is remarkable.

"CLANSMAN" IS COMPLETE

MANY have been the photoplays of six, seven, or eight reels for which it has been claimed that three or four or five thousand persons acted in their various scenes. So perfect has been the eye of the camera that its bold omnipotence has been



THE DRAMATIC-COMEDY COMPANY OF THE CROWN CITY FILM MFG. COMPANY (Paragon Brand)
(Releasing through Mica Film Corporation—Kriterion Program)

ELEANOR WOODRUFF A RED CROSS NURSE

If Eleanor Woodruff, Pathe leading lady, holds to her decision to go to the European war as a nurse, the world of the screen will suffer a severe loss. There are too few actresses of Miss Woodruff's type at present in films not to give her exit more than passing notice.

Though Miss Woodruff did not get her name in the bright lights on Broadway before her advent into the screen world, she played important parts in "The Gamblers," "Beverley of Graustark," "The Spendthrift," "The Five Frankfurters," and in stock.

At the suggestion of some of her friends she tried film drama and became an instantaneous success. Wonderfully versatile, her chief charm lay in her portrayal of emotional parts. Some of her best known film parts have been Katrina in "The Last Volunteer," as Beth in "All Love Excelling," as Mrs. Stevens in "The Stain," as Helen in "The Ticket of Leave Man," and others. She has just finished a part in another large production staged and produced for Pathe by George Fitzmaurice, which will be released soon.

After the outbreak of the war in Europe she became actively engaged in the work of the American Red Cross Society. Learning that the French house of Pathe had organized a number of Red Cross corps



ELEANOR WOODRUFF

from their large staff which they had equipped and are maintaining at the front at their own expense, and feeling deeply the shortage of hospital help to care for the large number of wounded and sick, she volunteered for this work. Her offer was accepted as the work of the Pathe studios had been largely suspended, and she leaves in a week or two to take charge of one of the Pathe field hospitals.

COHEN OF ALCO A BUSY MAN

Harry Cohen, of the Alco Film Corporation, is one of the busiest men in the film business these days. At present he spends most of his nights and days in taxicabs hurrying films from the various releasing companies to the Alco offices, at 218 West Forty-second street, New York.

War on White Plague Taught In New Feature

"For the Good o' Humanity," by Exhibitors Producing and Exchange Syndicate, Reveals Valuable Lessons on Tuberculosis—Stoermer the Producer

EXHIBITORS' Producing and Exchange Syndicate of Los Angeles has completed its first feature production, "For the Good o' Humanity," a six reel subject with a heart interest story that demonstrates the method used successfully by a well known sanitarium for the cure of tuberculosis if treatment is applied in the early stages of the disease.

The picture was produced by William Stoermer, who also wrote the scenario using an idea from a thesis prepared by a local physician and surgeon for the health department of the federal government.

"We will see the entire picture projected within the next few days," Mr. Stoermer said in the cutting room of the studio the other day, "when prominent members of the medical profession will be asked to see it and find a single scene that is not absolutely technically correct, and at the same time so depicted that it will make a very strong appeal to the laymen, and teach a great lesson with regard to health and happiness."

The company was organized by Mr. Stoermer, a well-known theatrical producer, one of whose greatest successes was the staging of the Oberammergau Passion Play at the Auditorium theatre in Los

Angeles two years ago, in which more than a thousand took part. The producer, who owns the American rights for this, played the part of Christ. Mr. Stoermer is president; Warren Gellilen, retired Los



WILLIAM STOERMER

Angeles banker, vice-president; Lute Gellilen, treasurer and business manager; and E. K. Oswald, secretary. The company has purchased what is known as the "Old Majestic studio," 619 Fairview avenue, Los Angeles. J. C. JESSEN.

Durango, Latest Addition to Alliance Ranks

New Company Locates Studio in Section of Colorado Noted for Wide Variety of Scenery—Will Release Eight Features a Year

ONE of the latest additions to the growing ranks of feature concerns is the Durango Film Producing Company. The organizer is G. V. Garrison, formerly a member of the firm of Middleton and Garrison. The studio has been located at Durango, Colo., thus offering an opportunity to produce pictures in a part of the country which has never been used for that purpose. The wide variety of landscapes which can be found within a short radius of the studio will make it a comparatively easy matter to take pictures calling for every type of scenery.

From Durango to the mines is a matter of only three hours. All kinds of backgrounds for Western and other scenes calling for mining and quarrying locations can be found in this district. Even nearer at hand is an Indian reservation on which about 20,000 Navajos and 3,000 Utes are permanent residents.

As many of these Indians as are needed can be obtained for pictures calling for the appearance of redskins. Another advantage is a large lake and a river on which are motorboats and other craft of many types. This will make it possible to obtain all sorts of water effects. Besides this there is plenty of mountain and prairie scenery, the former being particularly beautiful and for the most part of a type never seen on the screen.

The present plans call for the production of eight five-reel features a year. It is planned to make these first-class productions in every way, and to take full ad-

vantage of the exceptional scenic opportunities afforded by the location of the studio. The films produced will be released through the Alliance program.



ALIXE BEGS DOLTAIRE TO SAVE ROBERT'S LIFE ("Seats of the Mighty")

**ALLIANCE
PROGRAM**

**ALLIANCE
PROGRAM**

HEARTS AND FLOWERS

In Five Parts

FEATURING

MRS. THOMAS WHIFFEN

THE GRAND OLD LADY OF THE AMERICAN STAGE

SUPPORTED BY

MISS BEULAH POYNTER

AND A LARGE CAST. PRODUCED BY

COSMOS FEATURE FILM CORP. Released Nov. 30

RELEASES

**THE KEY TO YESTERDAY
THE PATH FORBIDDEN
AT THE OLD CROSS ROADS
THE HOOSIER SCHOOLMASTER
THE MAN WHO COULD NOT LOSE
WHEN FATE LEADS TRUMP
THE LAST CHAPTER
THE TRUTH WAGON
THE UNDER TRAIL**

From the Novel by
Charles Nevil Buck
From the Novel by
John Hymers
From Arthur C. Aistons'
famous play
From the great American
Story by Edw. Eggleston
By Richard
Harding Davis
From Novel by
Alice M. Roberts
By Richard
Harding Davis
From the play by
Hayden Talbot
From Novel by
Anna Alice Chapin

**CARLYLE BLACKWELL
OCTAVIA HANDWORTH
ESTHA WILLIAMS
MAX FIGMAN
CARLYLE BLACKWELL
OCTAVIA HANDWORTH
CARLYLE BLACKWELL
MAX FIGMAN
OCTAVIA HANDWORTH**

EXCHANGES

ALLIANCE FILM SERVICE, 115 Fourth Ave., Pittsburgh, Pa. A. A. Weiland, Mgr. *Ohio, Western Pennsylvania, Kentucky and West Virginia.*

ALL THEATRES, FILM AND ACC. CO., INC. Owners of Alliance Film Exchanges, New York State. Buffalo Office, 18 Chapin Block; S. S. Webster, Mgr.; I. Cobe, Gen. Rep. New York City Office, 126 West 46th St.

ALLIANCE FILM SERVICE, controlled by Eastern Feature Film Co., Inc., 57 Church St., Boston, Mass. *New England.*

ALLIANCE FEATURE FILM SERVICE, controlled by Mecca Feature Film Co., 130 West 46th St. *Northern New Jersey.*

ELECTRIC THEATRE SUPPLY CO., Vine and 13th St., Phila., Pa. *Southern New Jersey, Eastern Pennsylvania, Maryland, Delaware, District of Columbia.*

APEX FEATURE SERVICE, 417 Rhodes Building, Atlanta, Ga. O. P. Hall, Mgr. *Virginia, North Carolina, South Carolina, Georgia, Florida, Alabama, Mississippi, Louisiana.*

APEX FEATURE SERVICE, 510 McCall Bldg., Memphis, Tenn. M. Simmonds, Mgr. *Tennessee.*

APEX FEATURE SERVICE, 311 Andrews Bldg., Dallas, Texas. M. Levison, Mgr. *Texas, Arkansas and Oklahoma.*

CASINO FEATURE FILM CO., Dime Savings Bank Bldg., Detroit, Mich. *Michigan.*

CELEBRATED PLAYERS FILM CO., 64 West Randolph St., Chicago, Ill. *Illinois and Indiana.*

NAT A. MAGNER CO., Pacific Bldg., San Francisco, Calif.; 218 Superba Theatre Bldg., Los Angeles, Calif. *California, Nevada and Arizona.*

DES MOINES FILM SUPPLY CO., 218 Utica Bldg., Des Moines, Ia. *Iowa.*

MONARCH FEATURE FILM CO., 12th and Wyandotte Sts., Kansas City, Mo. *Missouri, Kansas and Nebraska.*

ZENITH FEATURE FILM CO., Lyceum Bldg., Duluth, Minn. *Minnesota, North and South Dakota and Wisconsin.*

ALLIANCE FILMS CORP.

126 W. 46th STREET
NEW YORK CITY



COSMOS FEATURES

"Made in America"

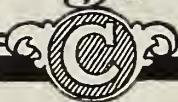

RELEASED NOVEMBER 30

Through Alliance Films Corporation



A
Thrilling
Drama
of Love,
Devotion
and
Sacrifice

Portrayed
in a Way
That Will
Make Your
Heart
Speak with
Sympathy

PRODUCED BY

Cosmos Feature Film Corporation

126-30 WEST 46th STREET

NEW YORK



Offices:
110 W. 40th St.
New York

Studios:
Los Angeles
California.

Presents

Carlyle Blackwell

In

The Five Part Photo Play

“The Man Who Could Not Lose”

From The Book By

Richard Harding Davis

A Notable Star

A Popular Story

A Famous Author

Previous Release

“The Key To Yesterday”

In Four Parts

From the Book By

Chas. Nevil Buck

Booked Through

the

Alliance

Film Corporation





EXCELSIOR

FEATURE FILM CO., INC.

Presenting

"WHEN FATE LEADS TRUMP"

In Four Parts
From the Book by Alice M. Roberts

with

OCTAVIA HANDWORTH GORDON DE MAIN
WILLIAM A. WILLIAMS in the Leading Roles

This story of a woman's trust, suffering
unwitting error, fear and final happiness
must interest all beholders.

Have You Shown?

Released Through

All Branches of
The

"The Path Forbidden"
In Five Parts

ALLIANCE

FILMS CORPORATION

From the Book by John B. Hymer

If Not—Do It!



EXECUTIVE OFFICE
110 WEST 40TH STREET - NEW YORK
SUITE 1002 - PHONE BRYANT 8059
ARTHUR ROSENBACH sales, mgr.

STUDIO
LAKE PLACID
N.Y.

"HEART OF THE NIGHT WIND"

(Victor-Universal—Three Reels)

REVIEWED BY PETER MILNE

WHILE with the Edison company Mary Fuller acquired a reputation as the embodiment of all that was poetic in a dramatic sense. The parts that were built for her especial personality would have been failures if given to a less accomplished actress than Miss Fuller. It was she who created them, and in creating them, her name was established.

From her performances witnessed up to the present time under the brand of Victor, she seems to have advanced considerably along these lines. This, of course, is natural, but would have presented greater difficulties if in the present pictures that she is appearing in, she was not directed by the same director, Walter Edwin, who formerly directed her. And then again, the other lead of the picture is Charles Ogle, whose name has long been associated with that of Mary Fuller.

The rest of the cast is new but fit into the general atmosphere of the picture in a way that calls for praise. Edmund Mortimer plays the hero of this picture, while Mr. Ogle is shifted to the role of heavy. William Morris and H. R. Barker assist the principals and the supers that appear are well trained.

The scenes of this picture are laid in a lumber camp and are very pretty. They seem to possess individuality, accountable in all probability to the fact that they have never appeared in other pictures. They are not familiar at least; are very well chosen, and are backed by photography only slightly below the regular Universal standard.

In plot the picture is simple yet always absorbing; practically two separate stories make their appearance, but they are connected by a well built series of events, and even though the second one neglects the former to a large extent, it will hardly be noticed by anyone.

By helping the lumber camp owner out of a great difficulty, "Heart of the Night Wind," as she is termed by the Indians, wins his everlasting gratitude. Later when she has grown to love him she is led to believe that he is false through a woman who loves the same man.

But he quickly puts matters aright and the story ends happily for the two lovers.

BOX OFFICE HAS STRONG ARRAY OF FEATURES

TWENTY-TWO features dealing with a diversity of problems and staged amidst varying surroundings are being released at stated intervals by The William Fox Box Office Attraction Company under the brand names of Balboa, Nemo and White Star. The players are known to all film fans.

Edwin August, with a Biograph and Universal reputation, Dorothy Davenport and Jackie Saunders, featured in Mutual and Universal films, Henry King, Neva Gerber, Henry Stanley and Daniel Gilfeather, all players who at one time or another have starred in films made by Vitagraph, Biograph, Lubin and other manufacturers, are known wherever pictures are shown throughout the world.

Edwin August is seen to advantage in "The Awakening" and "The Great Secret." Jackie Saunders ascends remarkable heights of histrionic effort characterizations of juveniles in "Little Jack" and "Little Sunbeam," "Rose of the Alley" and "Through Night to Light." Her clever performances are not only certain to attract attention but also bring her close to the heart of every movie fan. The others scintillate in "Storms of Life," "Seeds of Jealousy," "The End of the Bridge," "The Vow" and "Through Fire and Water."

These and a few more just as powerful are being booked through the Box Office exchanges located in New York, Boston, Syracuse, Washington, D. C., Pittsburgh, Kansas City, Cleveland, St. Louis, Dallas, Minneapolis, Denver, Seattle and San Francisco.

TAKING WRECK SCENES OFF MARBLEHEAD

O. A. C. LUND and six of the principals of the cast that is at present working on the production of "The Marked Woman," a five-reel feature that the Peerless Feature Film Company is to release shortly, are at Marblehead, Mass., taking a number of shipwreck scenes. The company will remain at the Massachusetts seacoast resort for about a fortnight. Those who traveled with Mr. Lund are Miss Barbara Tennant, William C. Bailey, George Cowl, William Edmondson, Joseph Baker, Mary Navarro and Fred "Daredevil" Probst.

EDISON AND "MIRROR" START PRIZE CONTEST

FOLLOWERS of motion pictures will be interested in a prize contest about to be started by the New York "Dramatic Mirror" in collaboration with Thomas A. Edison, Inc.

Mark Swan, author of the "Andy Series" and a score of other Edison photoplays, as well as successful plays for the legitimate stage, has written two-thirds of a one-reel photoplay, and "The Mirror" is offering a prize of fifty dollars for the best completion of the story submitted by a reader, four prizes of ten dollars each, for the next best endings, and a prize of ten dollars for the most suitable title.

The completed photoplay will be produced by Thomas A. Edison, Inc., with full credit on the screen to the contestant who supplies the prize winning ending.

The contest starts November 18 and closes January 9. Mark Swan's uncompleted scenario appears in the issue of "The Mirror," published November 18.

PHOTO PLAY PRODUCTIONS RELEASES "FORGIVEN"

THE Photoplay Productions Releasing Company, 37 South Wabash avenue, Chicago, is preparing to place upon the market "Forgiven; or the Jack o' Diamonds," featuring Edwin Forsberg, who played the part of the Jack o' Diamonds in the stage play of "Forgiven."

This picture is in six parts. The owners of the picture are resorting to an unusual method of advertising it by means of four-hundred twenty-four sheet billboards, distributed over Chicago, supplemented by newspaper advertising. They think well of the picture, otherwise, they would not be inclined to enter into such an enormous expense as this will entail. The picture will be out November 27.

HANDLES "NORTHERN LIGHTS" AND "CAPTAIN SWIFT"

NED MALLOUF, up to this time office manager of the Life Photo Film Corporation, has resigned as manager of the Life Photo Corporation, and has been constituted by them their booking agent and representative on the two prior feature releases of that company, "Northern Lights" and "Captain Swift."

Mr. Mallof will maintain his offices in the suite now occupied by the Life Photo Film Corporation at 220 West Forty-second street.

His successor as office manager of the company is William Tobias, formerly the northern New York State representative for that company.

PLAN \$250,000 THEATRE MERGER IN LOUISVILLE

Special to MOTION PICTURE NEWS

Louisville, Ky., Nov. 18.

FRED J. DOLLE, secretary of the Broadway Amusement Company, and some of his associates in the motion picture business are planning to form a new corporation with a capitalization of about a quarter of a million dollars and bring about the consolidation of the different companies which now control the new Alamo Theatre, the Ideal, Baxter, East Broadway, West Broadway, and probably a few other picture houses. It is expected that articles of incorporation will be filed here shortly.

NEW LUBIN SERIES TO RUN FOURTEEN WEEKS

FOLLOWING the series of "The Beloved Adventurer" pictures which has been successful beyond expectations, The Lubin Company will release a new weekly consisting of the adventures and sad experiences of "Patsy Bolivar."

Patsy's misfortunes are continuous and excruciatingly funny. The stories have been written by Clay M. Greene, and the first number will be released December 28, and continue one reel every Monday for fourteen weeks.

NEW ENGLAND SNAPS UP "AFTER THE BALL"

S. E. SHERMAN, manager of Sherman's Famous Feature Films, who owns the New England rights to "After the Ball," reports excellent business throughout this country for this well-known and successful picture. Sherman's Famous Feature Films are now established permanently at 611 Washington street, Boston, Mass., Room 401.



A TREAT AT OUR EXPENSE



THE WORLD FILM CORPORATION

believes in delivering quality plus without charging an extra dollar. That is why General Manager Lewis J. Selznick has arranged to place the great American photoplay masterpiece

"THE SEATS OF THE MIGHTY"

a feature which represents an investment of \$100,000 and eight months to make into the regular service of the

WORLD FILM CORPORATION

This great 6 part film triumph will be released Dec. 7. Exhibitors who are not receiving the World Film service and care to secure their magnetic features should communicate at once with the nearest branch of the

WORLD FILM CORPORATION

General Manager **LEWIS J. SELZNICK**
Is Keeping Up the Good Work

So that the World Film Corporation has the great pleasure of announcing that it has arranged to present that most famous American Star

LILLIAN RUSSELL

in a photoplay based on her greatest stage success

"WILDFIRE"

Written for her by George Broadhurst and George V. Hobart in which she was seen for seasons before crowded houses in every city in the United States and Canada

Work has started on this wonderfully attractive feature and the feature will be released Jan. 11.

For further information on this and numerous other feature magnets, communicate with the nearest exchange of the

WORLD FILM CORPORATION

LEWIS J. SELZNICK, Vice-President and General Manager

130 West 46th Street

New York

34 Branches Throughout the United States and Canada



VITAGRAPH

"EVERYTHING AGAINST HIM," Drama **Monday, Nov 30th**
Circumstantial evidence convicts a man. The reappearance of his supposed victim saves him. An all-star cast.

"SAVED FROM A LIFE OF CRIME," Drama in 2 Parts **Tuesday, Dec. 1st**
A boy's opportunity proves his worth and makes him a man. Give the boys a chance. James Morrison, Dorothy Kelly and George Cooper in the leads.

"THE MYSTERIOUS MR. DAVEY," Comedy **Wednesday, Dec. 2nd**
Quick wit and action saves Henry much marital unhappiness. He took a chance and had a narrow escape. Sidney Drew as Henry.

"THE MAN THAT MIGHT HAVE BEEN," Drama **Thursday, Dec. 3rd**
As we dwell upon what might have been our hearts are filled with happiness or regret. This picture is a dream of happiness. Leah Baird, William Humphrey, Leo Delaney and Anders Randolph are the cast.

"THE METHODS OF MARGARET," Comedy **Friday Dec. 4th**
Sauce for the goose is sauce for the gander. He employs female help, she employs male servants. Lillian Walker as Margaret.

"BUNNY'S LITTLE BROTHER," 2-Part Comedy **Saturday, Dec. 5th**
It's hard to tell him from John. Bunny's wife thinks she sees double. John Bunny, Jay Dwiggins, as his little brother, and Flora Finch are the principals.

SIX A WEEK

"THE MOONSHINE MAID AND THE MAN," Drama, Monday, December 7
"SUNSHINE AND SHADOWS," Two-Part Drama, Tuesday, December 8
"THE ATHLETIC FAMILY," Comedy, Wednesday, December 9
"PURE GOLD," Drama, Thursday, December 10
"A STRAND OF BLOND HAIR," Comedy, Friday, December 11
"BUTT-IN, THE BOOK AGENT," 2-Part Comedy, Saturday, December 12

VITAGRAPH ONE, THREE AND SIX SHEET POSTERS

The Vitagraph Company of America
East 15th St. and Locust Ave. **Brooklyn, N. Y.**

BROADWAY STAR FEATURES

RELEASED

A MILLION BID	5 PARTS	MY OFFICIAL WIFE	5 PARTS
GOODNESS GRACIOUS	3 PARTS	UNCLE BILL	3 PARTS
MR. BARNES OF NEW YORK	6 PARTS	THE PAINTED WORLD	3 PARTS
LOVE, LUCK AND GASOLENE	3 PARTS	FLORIDA ENCHANTMENT	5 PARTS
CAPTAIN ALVAREZ	6 PARTS	413	3 PARTS
SHADOWS OF THE PAST	3 PARTS	THE WIN(K)SOME WIDOW	4 PARTS
BINGLES' MELODRAMA	3 PARTS	THE TANGLE	4 PARTS
		THE LOCKED DOOR	3 PARTS

Produced by THE VITAGRAPH CO. OF AMERICA and Released Through
THE GENERAL FILM COMPANY'S SPECIAL SERVICE
By Arrangement With BROADWAY STAR FEATURE CO., Inc.

COMING

SYLVIA GRAY	4 PARTS	THE SAGE BRUSH GAL	3 PARTS
TWO WOMEN	3 PARTS	THE MAN BEHIND THE DOOR	
THE LITTLE ANGEL	5 PARTS	OF CANYON CREEK	4 PARTS
		From Book	

State Rights **THE CHRISTIAN** Apply Vitagraph-Liebler Feature
Still Available for Film Co., 116 Nassau St., N. Y.



YOU



WANT YOUR THEATRE TO PAY

THIS MEANS

RENFAX MUSICAL MOVIES

RENFAX FILM CO., Inc.

CHICAGO: 154 W. Lake St.

NEW YORK CITY: 110 W. 40th St.

LUBIN

THE PERFECTION OF PHOTO-MOTION

Do Not Overlook These Wonderful Pictures

(Book Through the General Film Special Service)

By Arrangement with Fred Mace

EVELYN NESBIT THAW
and her son, **RUSSELL WILLIAM THAW**, in
"THREADS OF DESTINY"

5 Reel Drama Direction—Joseph W. Smiley By Wm. H. Clifford

"STONEWALL JACKSON'S WAY"

3 Reel Drama Direction—Edgar Jones By Emmett Campbell Hall

TO BE RELEASED SOON

EDWIN ARDEN

8 Reel Drama By Edwin Arden IN "EAGLE'S NEST" Direction—Romaine Fielding

TO BE RELEASED SOON

RAYMOND HITCHCOCK

IN "THE RINGTAILED RHINOCEROS"
5 Reel Comedy Drama By Lawrence McCloskey
Direction—George W. Terwilliger

ROSE COGHLAN

And **ETHEL CLAYTON** in
"THE SPORTING DUCHESS"
7 Reel Comedy Drama By Cecil Raleigh Direction—Barry O'Neil

3 Reel Drama "THE SPY'S FATE" Direction—Joseph W. Smiley
By W. H. Lippert

IN PREPARATION

"THE COLLEGE WIDOW"

Featuring **ETHEL CLAYTON** and **GEORGE SOULE SPENCER**
5 Reel Comedy By George Ade Direction—Barry O'Neil

SIX REGULAR RELEASES EACH WEEK

"THE BELOVED ADVENTURER," Eleventh of Series, "The Serpent Comes to Eden" Drama.....	Monday,	November 23rd
"MOTHER'S BABY BOY"		
"HE WANTED CHICKENS" { Split Reel Comedies.....	Tuesday,	November 24th
"THE MAKING OF HIM"—Two Reel Drama.....	Wednesday,	November 25th
"WAS HIS DECISION RIGHT"—Two Reel Drama.....	Thursday,	November 26th
"HE WAITS FOREVER"—Drama.....	Friday,	November 27th
"YOU CAN'T BEAT THEM"		
"THE SERVANT GIRL'S LEGACY" { Split Reel Comedies....	Saturday,	November 28th

SPECIAL ONE, THREE AND SIX SHEETS.

Lubin Manufacturing Company, Philadelphia, Pa.

Chicago Office:
154 West Lake Street



CALIFORNIA
MOTION PICTURE
CORPORATION

PRESENTS

BEATRIZ MICHELENA
AND A NOTABLE CAST INCLUDING
ANDREW ROBSON AND **HOUSE PETERS** IN

SALOMY JANE

AMERICA'S
GREATEST
PICTURE
PLAY

ADAPTED FROM
BRET HARTES
CELEBRATED ROMANCE
AS DRAMATIZED BY
PAUL ARMSTRONG
AND ORIGINALLY
PRODUCED BY
LIEBLER & COMPANY

EXCLUSIVELY CONTROLLED BY
ALCO FILM CORPORATION.

FILMED IN THE
FAMOUS
CALIFORNIA
REDWOODS
UNDER PERSONAL
SUPERVISION OF
ALEX. E. BEYFUSS

BETTER LIGHT

LESS CURRENT

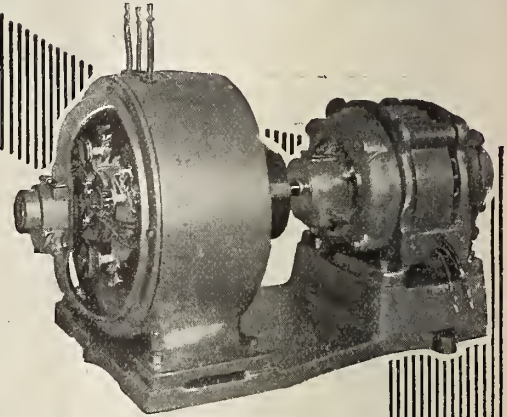
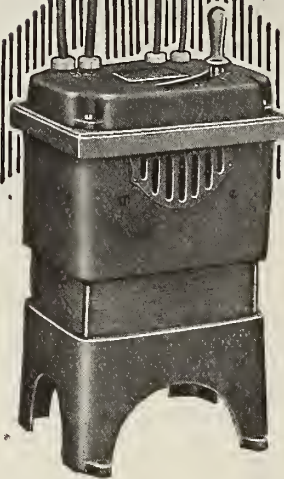
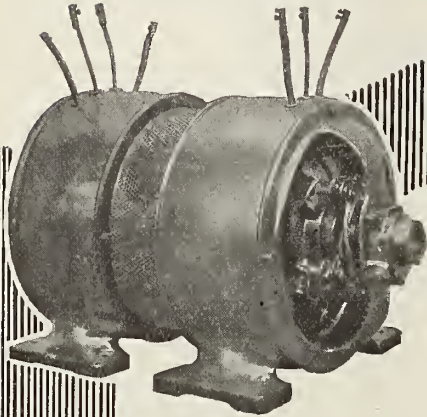

The DC Compensarc lowers the voltage of a direct current supply to that required at the lamp without needless waste.

The AC Compensarc cuts $\frac{2}{3}$ from your lighting bill if you use alternating current.

The AC to DC Compensarc will transform alternating into direct current and reduce the voltage at the same time without need less waste.

No matter what current you have---Alternating or Direct---or what voltage or frequency, one of the

FORT WAYNE COMPENSARCS

will enable you to secure a light that will give those clear, bright pictures that everybody now demands.

What's the use of paying extra money for special screens, projecting machines, and first run films and then spoil the whole result with poor light? With the Fort Wayne Compensarcs you can get any kind of light you want regardless of the kind or quality of your current supply.

The Compensarcs will give you

STEADY LIGHT. No flickering, no sputtering, even when changing intensities or from one machine to another.

WHITE LIGHT. No yellow streaks, no ghosts.

BRIGHT LIGHT. Three times the light with two-thirds the current.

They are safe, efficient, easy to operate, fool proof and reliable.

FORT WAYNE ELECTRIC WORKS

OF GENERAL ELECTRIC COMPANY

1704 BROADWAY

FORT WAYNE, INDIANA

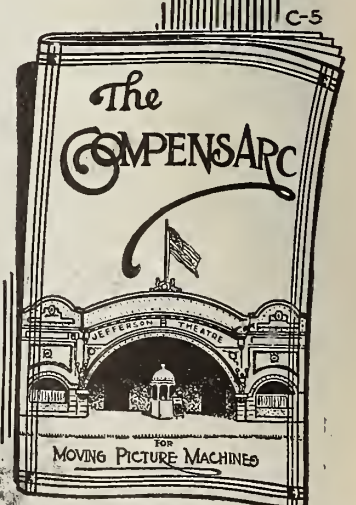

Compensarcs are so commonly found in motion picture theatres that many people now call all current saving and transforming devices by that name.

But Remember

*If it isn't a FORT WAYNE
it isn't a "COMPENSARC"*

*Send TODAY for this
FREE descriptive booklet*

NOVEMBER 28, 1914

Accessory News

THE CONSTRUCTION, EQUIPMENT AND OPERATION OF THE MODERN PICTURE THEATRE
VOLUME X

NUMBER 21

THE MOTIOGRAPH A WINNER

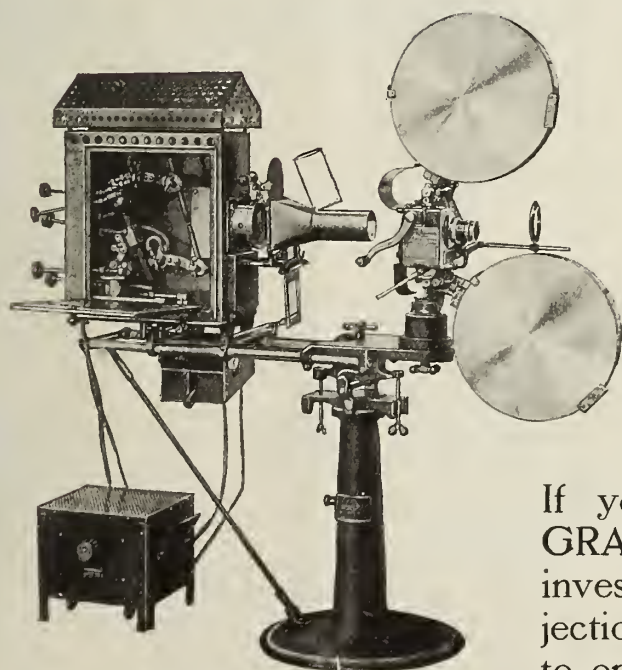

==== AT ====

**THE INDUSTRIAL FAIR
SAN FRANCISCO, CALIF.**

Whenever the MOTIOGRAPH is put to a test for long distance throw, rock steady pictures, bright and clear, even on low amperage, you have a sure *Winner* in the *Motiograph*.

If you are not using the MOTIOGRAPH today, it will pay you to investigate and find out why its projection is superior, life longer and easier to operate than any other machine.

The Enterprise Optical Mfg. Co.

568 W. Randolph Street, Chicago, Ill.

EASTERN OFFICE
19 W. 23d St., New York

WESTERN OFFICE
833 Market St., San Francisco

To WYANOAK PUB. CO.
136 W. 52nd Street,
New York City

Name

At your expense
send complete
information
about your
plan to the
above ad-
dress

WE WILL HELP YOU PACK YOUR THEATRE

THIS STATEMENT IS BACKED
UP BY ANY NUMBER OF TES-
TIMONIALS RECEIVED FROM
SATISFIED EXHIBITORS.

BOTH THE GENERAL AND
UNIVERSAL ENDORSE US
AND GIVE US THE EXCLUSIVE
RIGHT TO OUR PLAN.

CUT OUT COUPON CORNER
OF PAGE—STICK IT ON A
POST CARD, OR PUT IT IN AN
ENVELOPE AND MAIL IT TO
US.

YOU WILL THEN RECEIVE
WITHOUT OBLIGATION, COM-
PLETE INFORMATION RELA-
TIVE TO THE NEATEST,
CLEANEST AND MOST EX-
CLUSIVE ADVERTISING ME-
DIUM EVER OFFERED AN EX-
HIBITOR.

IT'S A BUSINESS BUILDER
BASED ON HUMAN INTEREST
AND WE BACK YOU UP—NOT
ONLY AT THE START—BUT
RIGHT THRU TO A BIG FINISH.

WYANOAK PUB. CO.

136 WEST 52ND STREET

New York City

MENGER & RING

302
W. 42nd
Street
New York

TELEPHONE
BRYANT 6621



PERFUMES DISINFECTANTS

SPRAYING DISINFECTANTS.

BOUQUET, 1 gal., \$2.50; 5 gal., \$10. Our best. Cannot be equaled
in strength and fragrance.
LAVENDER, 1 gal., \$2.00; 5 gal., \$7.50. REFRESHING.
SPEARMINT, 1 gal., \$1.50; 5 gal., \$5.00. POWERFUL.
PRICES INCLUDE LARGE SPRAYER.
50 cent. credit without sprayer.

PERFUMES.

Can be used with Fans or in Clay or Plaster Paris Cones.
Cinnamon \$2.50
Spearment 3.50
Lavender 3.50
Carnation 6.00
Bouquet 6.00
CONES 30 cents each.

YOUR MONEY REFUNDED IF NOT SATISFACTORY

We sold the first perfumed disinfectants in this country, and on ac-
count of manufacturing and importing direct, the quality at our price
cannot be beat.

GENDISCO

408 36th Street - BROOKLYN, N. Y.

10% May be deducted from above prices on
any order no matter how large if check
is sent together with this Coupon.
Offer only good up to January 1, 1915

Please send me the following.....
.....
.....
.....
Less discount of 10%.
Name..... Theatre.....
Address

Construction,
Equipment,
Operation

Accessory News

Everything for
the Modern
Picture Theatre

Tel. 7650 Bryant

NO. 220 WEST FORTY-SECOND STREET

New York City

Volume X

NOVEMBER 28, 1914

Number 21

Putting New Life Into the Balcony

ONE of the most remarkable moves in the recent development of the motion picture theatre is the growing tendency toward convenience for the patrons and installation of machinery which insures greater business efficiency.

The motion picture houses, which are being built in the larger cities of the country particularly, are works of art. They contain the very best of everything and in many cases are far superior to the "legitimate" houses. This is natural, for more people see pictures than go to the theatres.

How Shall I Bring Them Back?

In order to bring these patrons back day after day, courteous attendants, comfortable chairs and the like must be supplied, not to mention the showing of the best obtainable films with carefully studied projection. All these things and more must be looked into and supplied to insure increasing attendance.

While all this is being done by the builder or exhibitor who is remodeling, there is a question of self-protection which must be worked out. "How can I get the most out of my balcony? How can it be made the most attractive part of the house?"

This is a question of vital importance to every manager of a large house.

Present day admission prices to the up-to-date picture houses are far too low. Consider the cost of producing the pictures, the rental price and all the incidental expenses, and then stop to think what you are giving your patrons. When all this has been considered, how can you blame the man who says, "How can I fill every corner of my house?"

Present Prices Too Low

Two shows in the afternoon and two in the evening with but a short intermission in which to empty the house and fill it again means that speed must be employed or money lost. This speed must be effected without the patrons realizing it.

Houses without balconies usually are equipped with large exit doors which solve the question of allowing the audience rapid exit. The balcony type theatre which is the one with the largest seating capacity must be studied more carefully. The main things to be considered are:

First—The saving of time in filling and emptying the balcony.

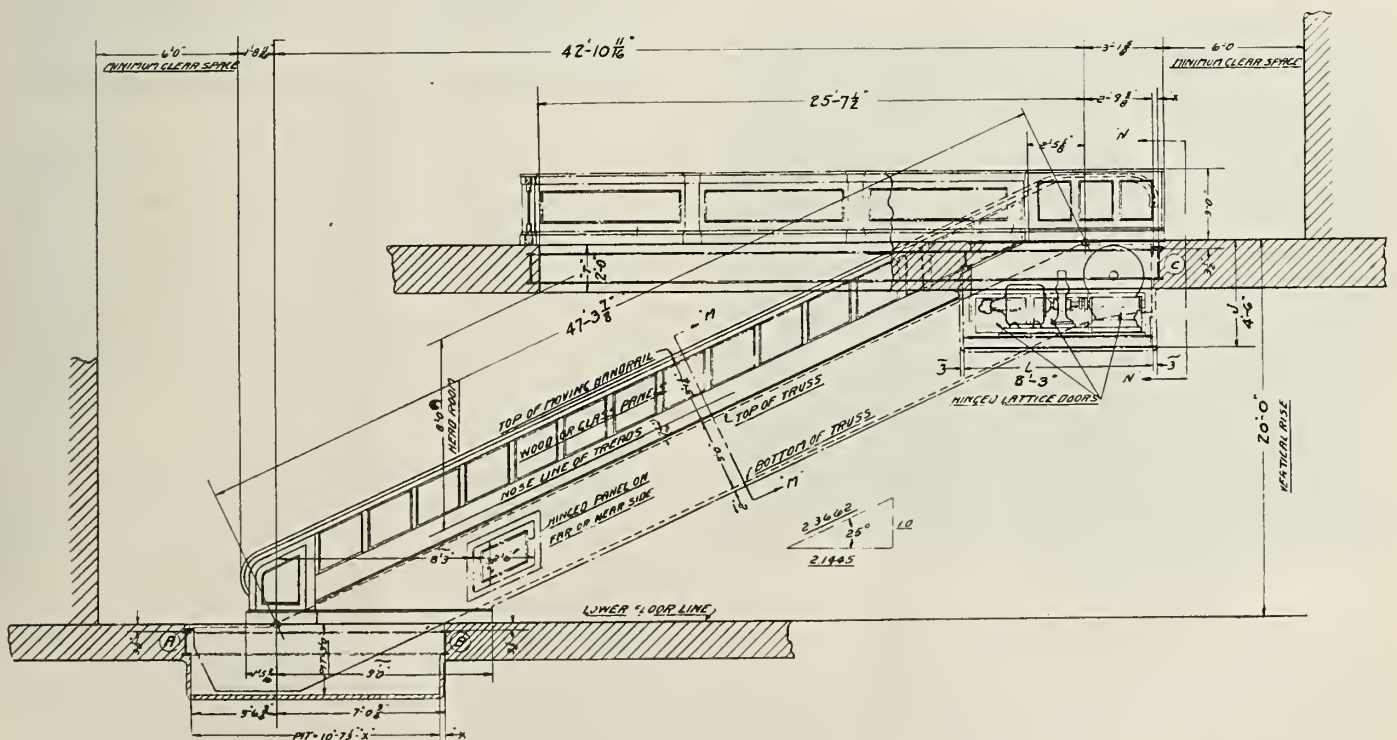

SECTION K-K

SIDE ELEVATION OF CLEAT TYPE, SINGLE FILE DESCENDING OR REVERSIBLE ESCALATOR (TYPE "RPC-B")

Second—The ability to charge higher prices for balcony seats.

Third—Added comfort to the patrons.

Fourth—The economy in room, for every foot is worth its price of admission at every show.

These troubles have been solved by many theatre owners by the installation of the Otis "cleat type" escalator system. This

OTIS ESCALATORS IN THE MODERN THEATRE

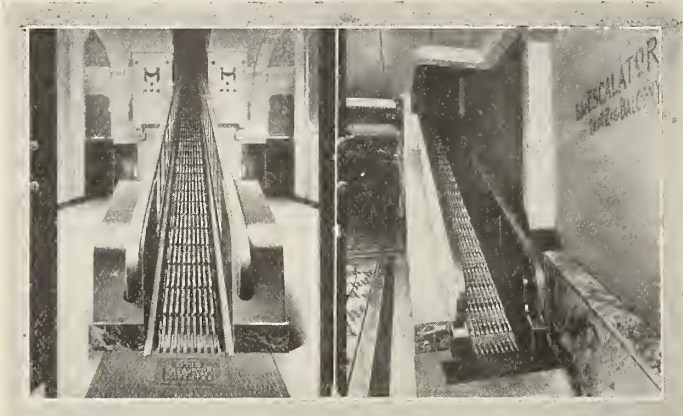

THE ESCALATOR MAY BE PLACED IN THE CENTER OF THE LOBBY OR AGAINST THE SIDE WALLS

does away absolutely with one flight of stairs to the balcony and enables the actual saving of space because the remaining flight need not be as wide as it otherwise would be.

Teach Public to Use Escalator

There would be no real need for a flight of stairs at all, were it not that some people are not educated up to the use of the escalator. The majority, however, prefer this quick and easy method of transportation and without their knowledge they are helping the theatre manager to overcome his greatest problem—the saving of time.

The capacity of the two-foot escalator is 3,600 per hour, while that of the four-foot is 11,000 per hour. This gives an idea of the efficiency of the installation from the time-saving point of view. In addition, it is absolutely noiseless, thus avoiding the usual confusion of stairs.

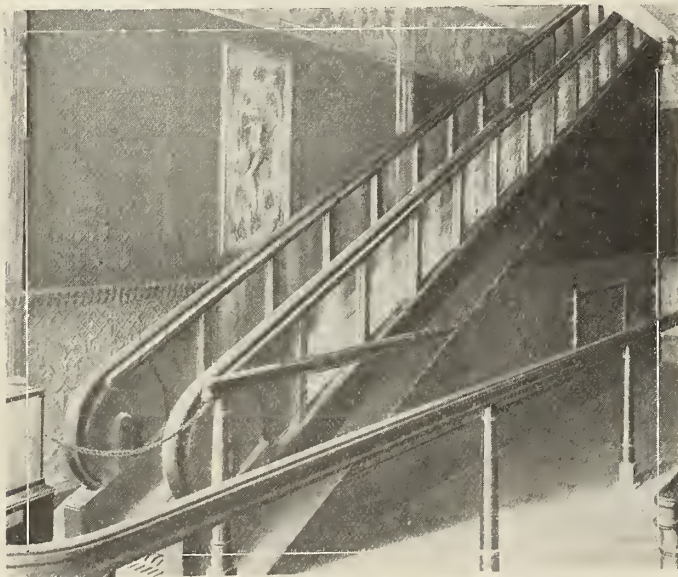

CLEAT TYPE OF ESCALATOR FOR THEATRES

The escalator also makes the balcony a far more profitable part of the house, for together with its ease of access it also means that the admission price can be raised. One of the progressive houses has gone so far as to charge the same price for balcony seats as those in the orchestra. Not satisfied with this it keeps the doors to the orchestra closed till the balcony is filled.

When the prices are not the same it allows the infirm to

attend the show without having to climb stairs or pay the orchestra prices.

The actual working of the escalator is very simple, for it takes but the turning of a switch to change the direction in which it is running. Figuring that the necessary current for running the escalator is but about thirty minutes each day, it is easy to see that the actual cost is light, whereas the saving in time and space makes its installation a decided advantage as well as good investment.

Comfortable for Passengers

The illustration shows the construction of the tread for the "cleat type" escalator which has proven itself to be very practicable and safe in operation.

The step treads are so nearly horizontal, the angle being only twelve and a half degrees, that the foot of the passenger is in



SIDE WALL ESCALATOR FOR THEATRES

a very comfortable position while riding either up or down.

They are made of hard maple bolted to a steel bushed chain which passes over sprocket wheels at the upper and lower ends of the machine. Attached to the treads at intervals of one foot

(Continued on page 116.)

Fire Panic Prevention Devices a Feature of Delft Theatre

UPON completion of his inspection of the new Delft Theatre building in Marquette, Mich., Deputy State Fire Marshal Dewey made the statement that he never inspected a more complete and better protected structure of its kind.

"It is as near perfect in this regard as a theatre could be built. It is the best equipped and most thoroughly protected theatre of its size in the State today."

The exits of the new playhouse and their locking arrangements were said to be exceptionally good. They open very easily and it would be almost impossible for a crowd to jam in the door ways; the slightest shove against them causes the portals to swing wide open to the outside.

Largest House in Buffalo Near Completion

MRS. LILLIAN M. HASTINGS, manager of the Victoria Theatre, Buffalo, and who will manage the New Victoria, announces that she has contracted for the Box Office, Alco and Shubert-Brady features, which means that the New Victoria will be the home of all the big productions in Buffalo.

The New Victoria will be the largest house in Buffalo devoted exclusively to photoplays. It will have a seating capacity of 2,500. A fifteen-piece orchestra under the direction of Herman E. Schultz has been engaged. There will be no balcony in the New Victoria.

Most luxurious fittings will be in evidence everywhere. The house is owned by the Mitchell H. Mark Realty Company, owners of the Strand, New York.

Projection

Fort Wayne AC Compensarcs Make Proper Voltage Reduction

THE Fort Wayne Compensarc is a static transformer device, designed to reduce the voltage of the incoming alternating current to that which is proper for the operation of the motion picture projection arc.

The device is complete in itself, there being no auxiliary device external to it. It is designed to be installed in the operating booth and at a position convenient to the operator, so that without moving from his place, he can, by adjustment of the control switch, vary the current flow through his projection arc.

The standard device is designed to give 30, 40 and 60 amperes, but may be furnished for any other three values of current, 60 amperes and below. The AC Compensarcs are furnished for either 60 or 133 cycle circuits, and for service, either 110 or 220 volts alternating current circuit.

In mechanical and electrical construction, the AC Compensarcs have the same excellence characteristic of power and lighting transformers, the same high grade sheet steel being used in the core, and the highest grade of copper wire and insulation being present in the coils.

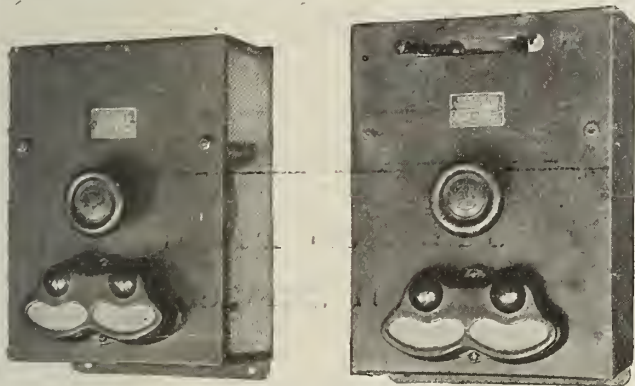

THE AMMETER

With the rheostat control on the 110 volt circuit, the arc being separated for 35 volts, the lost voltage is 110 minus 35, or 75 volts, which is equivalent to 68.2 per cent. The AC Compensarc, by using high grade silicon steel in the core and liberal cross section of rectangular copper in the windings, makes a saving of practically all of this lost energy.

Core on Cast Iron Base

The assembled core and coils are supported by a cast iron base having four legs which hold the device at a convenient height from the floor. The case proper, also made of cast iron, rests on top of the core in such manner as to protect the connections to the coils. A slate top resting on this case acts as a terminal board for the connections and support for the adjusting switch, the handle of which projects through the cast iron cover.

The handle of the adjusting switch is heavily insulated, so that there is no danger of the operator receiving electrical shocks, and the cover prevents any contact with live wires at this point. This adjusting switch is so arranged that the change from one value of current to another is made without breaking the circuit so that there is no need of the operator restriking an arc when adjustment is made.

The AC Compensarcs will not overheat. They are constructed electrically so that if the carbons of the arc lamp be left in contact with the circuits closed, the compensarcs will automatically protect themselves from burning out or blowing the fuses.

The control switch of the compensarcs has besides the three operating positions, a fourth position at which the circuit to the lamp is open; therefore, when the operator wishes to change carbons, it is not necessary for him to open the line switch; all that is necessary being that he set the switch of the compensarc at position marked "off."

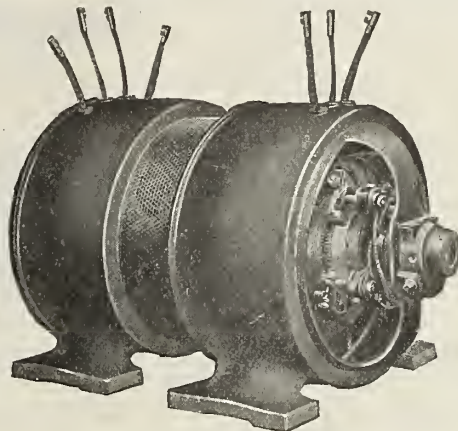

THE DYNAMO OR GENERATOR

The AC Compensarc is simple to connect in circuit. Two leads coming from the top of the device and marked "Line" are for connection to the power circuit, while two other leads labeled "Lamp" must simply be connected to the projection arc lamp.

Fort Wayne DC and AC to DC Compensarcs

The valuable features of the AC Compensarcs are that they are perfectly safe to handle, that they do not generate excessive heat and are absolutely free from danger of burn-out; that they occupy small space and can be placed in the operating room convenient to the operator, and withal, effect big savings of current from the line over that which would be consumed if a rheostat were used to secure the voltage reduction.

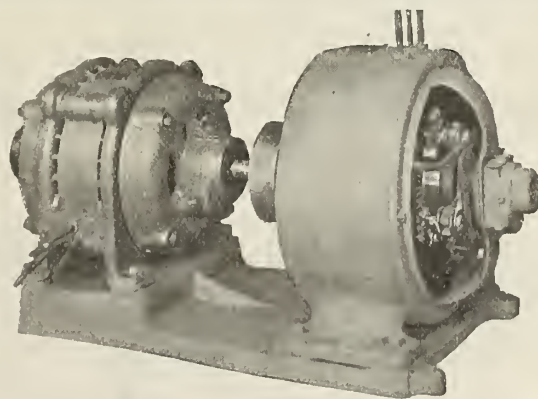

TYPE OF AC TO DC COMPENSARC

The Fort Wayne DC and AC to DC Compensarcs, like the AC Compensarcs, are designed to reduce the voltage of the incoming supply of electrical energy to an amount proper for the operation of the motion picture projection arcs.

Both the DC and AC to DC Compensarcs may be classed as

(Continued on page 109.)

Your Operator Can't Help It

Neither can the maker of your glass announcement slides—they are bound to break!

Our Patented Brass Slides Are Absolutely Indestructible—cannot crack.

They project a neat, clear, easily read announcement, and will last for years.

More than 90 stock designs. Special slides to order.

Stock slides, 25 cents each.

For sale at all branches of the General Film Co., Inc., and all Mutual Film Co.'s Exchanges and all Live Dealers and Glass Slide Manufacturers.

BEHREND MOTION PICTURE SUPPLY HOUSE

440 Fourth Ave. Branch: 71 W. 23rd St.
New York City

SEND FOR COMPLETE LIST

Patented
Serial No.
757689



Stock Slides, 25c.

Patented
Serial No.
757689



Open
Space Slides, 35c.

Patented
Serial No.
757689



Clock Slides, 50c.

A clear picture

is as essential as a good scenario. Because the basic product is right the clearest pictures are on Eastman Film. Identifiable by the stencil mark in the margin.

EASTMAN KODAK CO.,
ROCHESTER, N. Y.

"Master White" Screen and Curtain Coating

The finest white ever produced.

Can be applied to any cloth without sizing.

A child can apply it.

Note: Master White is Fire and Waterproof. It is guaranteed not to crack or peel.

\$500.00 A Bona-Fide Offer **\$500.00**

It contains no lime, glue, or whiting.

It is virtually a pure white glass preparation.

The greatest screen or curtain coating ever produced.

Ready mixed and ready to apply.

Cost first and only cost. \$10.00 per gallon.

One Gallon will coat a screen 18 x 24.

J. H. GENTER CO., Inc.
NEWBURGH, N. Y.

Makers of Mirroide. The
King of all projection surfaces.

Samples of Mirroide—the Greatest, the Best Metalized Screen the
World Ever Produced—Free, Free, Free. Do It Now—Write.

Get The Best From Your Film Service

Hold your patrons by making every picture you show clear and brilliant with sharp detail—do it by projecting through

Bausch^{and} Lomb Projection Lenses

Successful owners now realize the immense value of using Bausch & Lomb objectives, and wise operators are demanding them on the machines they use. Bausch & Lomb Lenses are regularly supplied with Edison and Nicholas Power machines and are procurable at all exchanges.

*Send for our interesting free
booklet for owners and operators.*

Bausch & Lomb Optical Co.
569 ST. PAUL STREET ROCHESTER, N. Y.

ATTENTION!

OPERATORS AND EXHIBITORS

You Use the Best Projector.
Why Not the Best Reel?

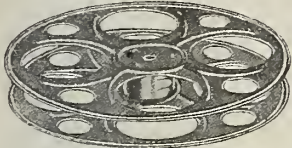

Our Improved Pat'd All-Steel 14-in. Reel. The strongest, the lightest, the most economical, the most efficient. Absolutely rigid rims with flanged edges. Readily accessible and "sure hold" threading device. White nickel finish.

Sent prepaid upon receipt of \$1.25 in New York Draft, Money Order or Cash.

THE TAYLOR-SHANTZ COMPANY

222 Mill St., Rochester, N. Y.

LANG'S FILM REELS

THE BEST MADE

14 in. \$1.50 12 in. \$1.25 10 in. \$1.00

CATALOGUE

LANG MFG WORKS, Olean, N. Y.

"EVERYONE'S USING"

Our Developing Tank System

Get No. 6 Price List

A. J. CORCORAN, Inc.

9 1/2 John Street New York

Send today for a
FREE SAMPLE

of the

NOVELTY TYPEWRITER SLIDE

for quick, inexpensive screen
announcements.

NOVELTY SLIDE COMPANY,

67 West 23d St. New York

Our Factory Is Yours!

Negative assemblers, projecting machines and an equipment second to none, with an organization of experienced people always at your SERVICE for DEVELOPING and PRINTING.

EVANS FILM MFG. CO.

Incorporated

416-22 WEST 216th STREET
Tel. 7652 Audubon at Broadway, New York

PROJECTION

(Continued from page 107.)

motor-generator sets, inasmuch as each machine has two separate armatures and two separate frames, but both compensars are different from the ordinary motor-generator sets in regard to the electrical windings.

In the DC Compensarc, both armatures are mounted on the same shaft supported by two bearings, which are built into the outer end flanges of the magnet frames. A special intermediate flange holds the two magnet frames rigidly in position so that no sub-base is required to maintain them in perfect alignment.

The windings of the DC Compensarc are similar to that used in the ordinary direct current balancer sets but are varied so as to give a peculiar volt-ampere characteristic curve, such that when the current at the arc reduces, the voltage automatically increases in such manner that a stable arc results, without using any lamp steadying resistance.

This winding absolutely protects the machine from the blowing of the fuses, over-heating, or other damage, when the arc carbons are left in contact. This is especially valuable to the operator in that it allows him to fry the carbons together when burning the crater into proper shape.

Motor End Has Three Heads

The motor end of the direct current compensarc has three leads, so that it may be connected to a standard direct current motor starting box equipped with no voltage release, so that in case the supply voltage fails, the machine will be automatically protected.

The generator end of the outfit has two main leads which go to the motion picture arc lamp, and a smaller lead which goes to the small generator field rheostat by means of which the operator controls the machine, easily increasing or decreasing the current in the picture machine arc lamp.

In mechanical and electrical construction the machines have the same excellence that is characteristic of larger power motors and generators. They are so small that they can usually be installed directly in the operating booth, as they require no special foundations and are practically noiseless in operation. They economize in the use of electrical energy from the line and practically eliminate fire risk.

The AC to DC Compensarc besides making the necessary reduction in the voltage of the incoming supply of electrical energy, also converts the alternating current into direct current for use at the projection machine arc lamp. The motor end of the AC to DC Compensarc is a standard induction motor of single-phase, two-phase, or three-phase, depending upon the kind of current supplied to the theatre.

The generator end of the set is mechanically and electrically quite similar to the generator end of the DC Compensarc, but the inner bearing in the motor supports the armature of the generator at the one end through the rigid shaft coupling which joins the shaft of motor and generator.

Peculiar Volt-Ampere Traits

Similar to the DC Compensarc, the generator end of the AC to DC Compensarc has a peculiar volt-ampere characteristic which automatically causes an increase in voltage when the current in the arc is reduced so that the same steady arc results without the use of lamp steadying resistance.

We Can Equip Your Theatre Complete

We are Distributors for the Powers, Edison, Motiograph and Simplex Machines, and Genuine parts, also Poster Frames, Indirect and Semi-Indirect Lighting Fixtures, Tickets, Screens, etc.

We sell for cash or on the easy payment plan.

Write today for our new catalog just off the press.

AMUSEMENT SUPPLY CO.

160 No. Fifth Avenue

Chicago, Illinois

Be sure to mention "ACCESSORY NEWS" when writing to advertisers.

SAVE 35%

on your

CARBONS

Burn your stubs with a

**CARBON
Economizer**



Pat. applied for.

Fits any lamp, gives perfect contact and conductivity made of special material, screw does not come in contact with carbon and will not weld to body of economizer; will burn upper or lower carbon to 3/4 of an inch.

OVER 1000 IN USE

"MECHANICALLY CORRECT"!!

Guaranteed to give satisfaction

\$1.25	Sizes	\$2.00
Each.	1/2"-5/8"-3/4"	Set—any sizes.

Sent postpaid upon receipt of New York Draft, Money Order or Cash.

**THE CARBON
ECONOMIZER CO.**

757 W. Onondaga St., Syracuse, N. Y.

SAVE 5 DAYS!

WHY
NOT

Let us develop your negative and make your prints under your own supervision. We will

SHIP
FROM

our modern laboratories in

LOS ANGELES

Direct to your customers.

**INTERNATIONAL
LABORATORIES**

3123-25 So. Hoover St.,
Los Angeles.

Projection

The machine is automatically protected from the blowing of the fuses, over-heating, and other damages, when the arc carbons are left in contact, so that the operator can fry his carbons together when burning the crater into proper shape.

The motor of the AC to DC Compensarc is connected to the line in the manner regularly employed in connecting induction motors. The generator has the leads necessary for the connecting of the lamp and field controlling rheostat.

The same quality of materials and grade of workmanship used in the construction of large power motors and generators enters into the construction of these sets. They are small and practically noiseless in operation and, since they require no special foundation, they can usually be installed directly in the operating booth. They are economical in the use of electrical energy from the line and practically eliminate fire risk.

Both the DC and AC to DC Compensarcs are built in different sizes so as to be especially suited for the operation of a single arc, or two projection arcs used alternately.

They are supplied for service on all standard commercial supply circuit voltages, so that there is a machine, particularly adapted, for practically every motion picture proposition.

The Value of a Carbon Economizer

WHEN the European war was a certainty many of the exhibitors and exchange managers made an effort to secure all the available imported carbons that they could purchase at the regular price. Many were satisfied to pay more than the normal price because it was evident that there would be a shortage in this necessary commodity and that the article in a short time would be selling at a premium.

This has come true and at the present time imported carbons are 300 per cent. higher than they were three months ago, and those made in this country have also taken a jump in price.

With an article so necessary selling at such an increase, it brought to the minds of many the waste that exhibitors have shown previously and some way in which this unnecessary waste of 40 or 50 per cent. of a carbon could be eliminated.

This waste has been overcome by the Carbon Economizer which



COMPENSARC CURRENT SAVING DEVICE

was invented by Claude Talley, former manager of the Regent Theatre, New York City, and president of the Regent Theatre Company. Mr. Talley conceived the idea of the Carbon Economizer when trouble first started among the European powers and at that time applied for a patent on the device.

The Carbon Economizer is made of brass composition. This is a good conductor, will stand excessive heat and will not increase resistance. They are $3\frac{1}{2}$ inches in length; $1\frac{1}{4}$ inches is allowed for support in the jaw of a lamp, the other $2\frac{1}{2}$ inches to hold the carbon. The device is made in $\frac{1}{2}$ inch, $\frac{5}{8}$ inch and $\frac{3}{4}$ inch sizes, is round to give perfect contact, and will burn a carbon from 6 inches to $\frac{3}{4}$ inch.

The section that holds the carbon is split in the center on both sides to allow for tension on the carbon and will spring back when the tension is released to remove the carbon. As the carbon burns the tension can be released, the carbon moved up until it is held by one-quarter of an inch and then burned until it is from one-half to three-quarters of an inch from the end of the economizer.

In order that the tension screw will not come in contact with the carbon and consequently weld to the body of the device, a collar fits around the top of the economizer, which is pinned to the body; the screw passes through this collar to the outer portion of the body. When the screw is turned it presses the walls of the economizer together and holds the carbon firmly in the container until the screw is loosened. The tension screw is made to allow for expansion of the metal under heat and can be turned without injury when red hot.

The Life Limit of a Motion Picture Machine

THE question has been asked "How long will a motion picture machine last and give good service under present day requirements?"

At a dinner party a couple of years ago, one of the prominent manufacturers expressed the opinion that the average life of a motion picture machine is about two years, but it seems that all manufacturers do not agree on this point.

In December, 1907, the Colonial theatre, of Kalamazoo, Mich., then under the management of W. H. Johnson, purchased the first Motiograph machine that was turned out by the Enterprise Optical Manufacturing Company. After having been in continuous use during the seven years, the factory has the following letter from the present owner of the machine:

"Enterprise Optical Manufacturing Company.

"I would advise that the machine in question is in very good condition and the results obtained with it are very satisfactory.

"Yours truly,

"H. H. B."

Some time later the manufacturers offered within \$75 of the original cost of the machine to be allowed as a credit on a new machine, but the offer was rejected. The incident is, to say the least, a significant one in projection history.

Manufacturers of the Wonderful
Rembusch Patented Glass MIRROR SCREEN
and all other kinds of
Curtains for Moving Picture Projection

GLASS SCREENS	METALLIZED SCREENS
Mirror Screen	Gold Fibre
Mirror Screen Split	Silvercloth
Glass Transparent Screen for Rear Projection	Mirror Cloth
	Seamless, with stretchers
	White Opaque
Phone Seven-Eleven	F. J. REMBUSCH, Pres.

MIRROR SCREEN COMPANY

Incorporated

SHELBYVILLE, INDIANA

Mr. O. P. Sammons of Denison, Texas, bought a "Mirror Screen," and he writes that he cannot take care of the crowds. His picture is simply the talk of the community. A few second-hand screens for sale cheap.

Eastern Representative, Frank Manning, 125 W. 48th St., N. Y. Phone, Bryant 2416.

Building and Furnishings

Beautiful Theatre Adorns Kansas City

A MOTION picture house comparing with anything in the East for architectural beauty is the Willis Wood of Kansas City. It has all the imposing grandeur of an Italian palace, and is a fit structure for the exhibition of the best in film drama. The accompanying illustrations testify to the magnificence of the Willis Wood.



EXTERIOR OF THE WILLIS WOOD, KANSAS CITY

It was formerly a Klaw and Erlanger "legitimate" house, and cost \$300,000. The Lappe and Tigh Amusement Company, the new lessee, spent \$50,000 in remodeling and furnishing. The theatre seats 1,600.

One of the features of the house is a subterranean passage to the Baltimore Hotel, permitting the guests to patronize the theatre on rainy nights without exposing themselves to the weather.

A \$20,000 pipe organ has been installed, and a seventeen piece orchestra will be a drawing card of the entertainment.

Features will be used exclusively—General, Alco and the World Film companies supplying the pictures.

The prices are ten and twenty cents. The theatre opened with Annette Kellermann in "Neptune's Daughter."

There are elaborate waiting rooms, in charge of maids, for women patrons, and smoking and lounging rooms for the men.

The theatre will probably have full houses continually, drawing from the best patronage of the city.

Escanaba Theatre Installs Wurlitzer

MANAGER HINES of the Bijou Theatre, Escanaba, Mich., has installed a new Wurlitzer organ, and daily recitals will be given in connection with photoplays.

Ellen Terry, Buffalo, Will Soon Open

THE new Ellen Terry at the corner of Potomac and Grant streets, Buffalo, N. Y., will open soon under the management of Charles Johnston, formerly manager of the International Theatre at Niagara Falls, N. Y.

The Ellen Terry will be one of Buffalo's highest class theatres devoted exclusively to motion pictures. It is located in the heart

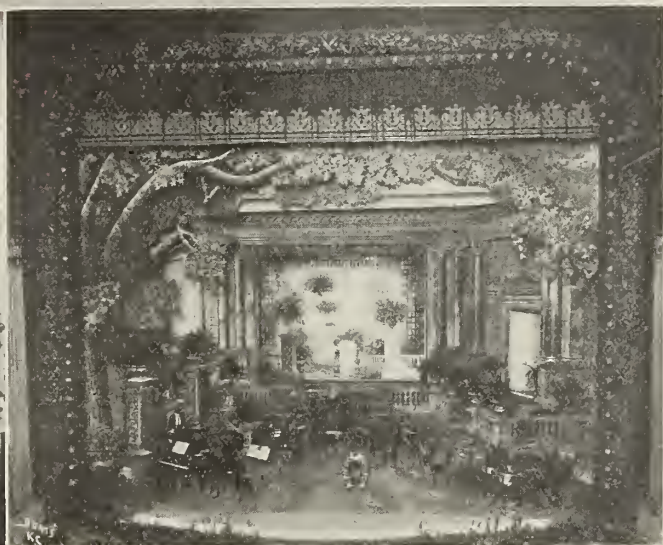

INTERIOR, SHOWING THE STAGE AND SCREEN

of the residential district of the west side and will draw upon the best patronage in the city.

"Better" features and "best" music will soon make the Ellen Terry a popular photoplay house.

Mikado Theatre, S. Louis, Changes Owners

THE Mikado Theatre, at 5900 Easton avenue, St. Louis, has been acquired by Scherer Brothers, who also operate the Palace Theatre, 1310 Franklin avenue. The new management have arranged for an all-picture program for the Mikado, featuring Paramount pictures. The Mikado, one of the largest houses in the city, was built by the O. T. Crawford Company three years ago, and formerly run a mixed bill of vaudeville and pictures.

Regent on the Coast Starts in Spite of Friday

THE New Regent Theatre at Riverside, Cal., owned and managed by Messrs. Howe & Merrill, was opened Friday, November 13, with no sign of a hoodoo in sight. The program consisted of "My Official Wife," and the prices were ten and twenty cents. The theatre has accommodations for about 900, and is spoken of as one of the handsomest small city theatres.

Life Size Lobby PHOTOGRAPHS Boost Box Office Receipts

Original negatives of leading players of all West Coast studios in straight or character poses.

DISPLAYS NOW READY*

The Spoilers
St. Elmo
Little Sunbeam

The Avenging Conscience
Will O' The Wisp
The Hoosier Schoolmaster

The Key to Yesterday
The Man Who Could Not Lose
Terrance O'Rourke Series

The Blood Red Rose

DISPLAYS OF COMING RELEASES
The Carpet From Bagdad

The Rosary

*Displays include either character or straight photographs. Introductory offer closes December 1st. WRITE NOW.

PHOTOPLAYERS' STUDIO

342 SO. BROADWAY

LOS ANGELES, CAL.

Only exclusive professional studio on Pacific Coast where 80 per cent. of American motion pictures are made.

Directory of New Theatres

EDITOR'S NOTE.—The information contained in the "Directory of New Theatres" is gathered by the field representatives of "Motion Picture News" and the facts and figures in each instance have been verified by them and are authentic. They may be relied upon by members of the trade.

Kunsky's Alhambra Opens in Detroit

JOHAN H. KUNSKY'S newest enterprise, the Alhambra Theatre, at 2124 Woodward avenue, corner of Kenilworth, Detroit, Mich., was formally opened Tuesday evening, November 10, or one week previous to his expectations of thirty days ago.

As for the theatre itself, Mr. Kunsky can well be proud. It fully lives up to the caption used in the program which reads "The most beautiful and perfectly appointed photoplay theatre in Detroit." Mr. Kunsky has had the advantage of building other theatres (he now controls eight) and naturally he collaborated with the architect in bringing about as fine a theatre for pictures as it was possible to obtain. No detail was overlooked. Photographs and a more detailed story will appear in a later issue of the *MOTION PICTURE NEWS*.

Suffice it to say that it seats 1,500 people and will cater to the high-class trade. The opening attraction was Mary Pickford in "Behind the Scenes." That is the standard of photoplays which will be given as the permanent policy. The program announces the fact that matinees will be given daily, with an extra one on Saturdays, and that in the evening performances will be continuous from 6:45 to 11. On Sundays and holidays performances will start at 1:45 in the afternoon and run until eleven at night.

Prices are 10 cents for the matinees and 10, 15 and 20 cents at night, 10 being for the first 20 rows, 15 for the balance and 20 cents for the box seats.

T. D. Motle, formerly manager of the Liberty Theatre (also owned by John H. Kunsky), is in charge of the Alhambra. For a while he managed the Garden Theatre, and previous to his coming to Detroit he was connected with one of the big picture producing companies in New York. The orchestra at the Alhambra is conducted by Fred L. Neddermeyer, and the organist is Charles L. Wuerth.

The theatre was designed by C. Howard Crane, architect, who has planned all of the Kunsky theatres, and was built by Frank Farrington & Co., contractors. The total cost of the theatre, with furnishings and equipment, was \$100,000. The Alhambra is four miles away from the downtown section of Detroit, but is in a residential district that is populated with successful business people, and is on the main business thoroughfare of the city, Woodward avenue. Pictures will be changed daily at the Alhambra.

Alamo Opens in Louisville

THE new Alamo theatre, Louisville, claimed to be the most modernly appointed and prettiest motion picture theatre in Kentucky, was opened for the first time to the public on Saturday afternoon, November 14.

Several union men at work on the building were called out on strike a few days ago, when it was found that non-union men were installing seats, but the matter was adjusted.

The interior of the Alamo is most artistic, the walls and ceilings being designed after the style of the Italian renaissance. All of the illuminations are overhead in ivory bowls suspended from copper chains so that the soft rays of the yellow sun globes will be reflected from the ceiling. Outside the theatre, the renaissance front will be bathed in electric lights from twelve showers.

The ventilating system incorporates the very latest ideas to insure an atmosphere conducive to health and pleasure. A large draught fan draws fresh air into the house from the outside and the air passes through porcelain tubes and is thoroughly washed before released.

The Alamo has seven spacious exits, two of which lead to the rear of the stage. A large fountain with vari-colored lights re-

flecting through the spray has been installed on the stage. A twelve-piece orchestra will have a place on the stage directly beneath the picture screen.

Another music feature will be a Wurlitzer orchestration.

The Alamo opened with the Mutual program and has contracted with this corporation for the first and second run of this service in Louisville. One of the features of the opening day was the two-reel Keystone comedy, "Dough and Dynamite," featuring Charles Chaplin.

St. Louis Has Theatre Building Boom

SIX new theatres have been completed in St. Louis during the last three months. The list includes the Strand, at Sixth and St. Charles streets, a continuous house from 10 a. m. to 11 p. m., that seats 500. The Lindell, Grand avenue and Hebert street, with seats for 2,000 patrons. The beautiful West End Lyric, at Delmar and Euclid avenues, with 1,100 seats. The Olympia Theatre, 1420 Market street, a new continuous house, with a capacity of 750.

The Duchess, Grand and Washington avenues, which seats the same number, and the Powhatton, at 7200 Manchester avenue, a 1,000-seat house. The above-named houses are all of the highest class throughout, and cater to the better class of audiences, and all but one charge ten cents admission.

In addition to this a new theatre is being built at Grand and Florissant avenues; another is projected for North Sixth street, near Pine; one for the block on Delmar avenue, between Hamilton and Goodfellow avenues, and a 600-seat house for 1700 South Broadway.

Milwaukee Will Have First Chinese Film Theatre in America

BY next year Milwaukee, Wis., will have the first Chinese motion picture theatre in the country. Charley Toy, 174 Second street, a rich Chinaman, has announced that within the next year he will open a feature photoplay house in the Toy building, playing week stands of the biggest features available.

The theatre, according to Mr. Toy, will be 40 x 150 feet, and a Chinese scheme of decorations will be followed throughout. Chinese artists are to be imported to do the work. According to Mr. Toy, the cost of the decorations alone will go well into the thousands.

He also announces that one of the features of the house may be a Chinese orchestra.

Theatres Here and There

RAY MARVIN and Harry Travis opened a new motion picture theatre in Hoopston, Ill., Saturday, November 14. The theatre is known as the Lyric and is located in the new Dyer building, corner Main and Bank streets. Everything is to be modern throughout and the interior and exterior are to be beautifully decorated.

The Lyric theatre, Upland, Cal., owned by M. Whitmore, is being remodeled to accommodate twice as many people as formerly, and new Powers 6-A machines will be installed.

Charles Robinson, who formerly owned the Alhambra theatre at San Pedro, Cal., has purchased the only theatre in Covina of Wells C. Mervin.

The theatre has a seating capacity of three hundred. For the present the policy of the house will remain the same, Mr. Robin-

Directory of New Theatres

son continuing with a General program and the "Perils of Pauline" series one evening every two weeks.

Frankfort, N. Y., is to have another motion picture theatre. Philes Thibault, of Clayton, recently purchased a lot on Litchfield street and is erecting a theatre. The building is 30 feet front with a depth of 65 feet and the space between joints inside is 18 feet and is built of tapestry brick. The ventilation will be perfect, the building will be fireproof and everything will be up to date. The seating capacity will be 450.

Grand Reopens in Reading, Pa.

The Grand theatre, Reading, Pa., has been reopened as a moving picture house.

D. R. Letson and W. H. Linton, of Little Falls, N. Y., who have been conducting the Empire moving picture theatre in Utica, have sold out that business to H. P. Clark, of Ossining, who has sold to them his Alhambra theatre at the latter place.

Michael Boone, of 799 Hallett street, Bridgeport, Mass., has purchased the Donovan moving picture theatre on Maplewood avenue and is having plans estimated for changes to the building. He will build an addition to the rear and will make interior changes.

The Lyric theatre, Fitchburg, Mass., has passed into the hands of a corporation of moving picture men, showing the Paramount pictures.

The Odeon theatre, Washington, D. C., has reopened for the winter under new management, with T. J. Nicholson at the helm. This is a resident theatre offering only evening performances of five reels for five cents. Sunday, however, is a ten-cent show, when two additional reels form the program.

Grand Closes in Atlanta

The Grand, Atlanta's biggest playhouse, has closed its doors as a moving picture theatre. The fate of the theatre for the rest of the year depends on a conference to be held in New York between Harry B. Hearn, the resident manager, and the lessee, Jake Wells.

Mr. Hearn explained the closing of the Grand as a motion picture house with the statement that really big feature films are extremely scarce and that only about one a month is procurable.

Under the management of Mr. Hearn the Grand has made a splendid record in Atlanta. Mr. Hearn himself holds a high place in the esteem of local exchange men and exhibitors who trust that the closing of the Grand will not take him from Atlanta.

Morris Slotkin, general manager of the Olympic theatre, Buffalo, N. Y., has sold out his interest in the Plaza theatre in William street to L. Michaels and Jacob Rosen. The Plaza will be conducted as a vaudeville and motion picture house, as in the past. Mr. Slotkin will devote his attention entirely to the Olympic theatre.

New Theatres in Louisville

The new Knickerbocker theatre at Eighteenth and Market streets, Louisville, Ky., was thrown open to the public for the first time this week. William Tapp, who has been connected with the Majestic theatre, is managing the new house. The Knickerbocker is of brick construction and presents a pleasing appearance both inside and exteriorly. The capacity is 600. The Universal service is being used and five cents is the admission charge. The theatre is situated in the midst of a thickly-populated neighborhood and the outlook for its success is bright.

The Shelby Amusement Company has accepted plans for a new motion picture theatre to be built at Shelby and Guendaline streets, Louisville. Ground will be broken for the foundation this week. H. B. Strube, manager of the Empire theatre, who is interested in the project, says that he expects the new house will be completed some time in March. The building will be of fireproof construction and will cost about \$22,000. The seating capacity will be 950.

H. K. Bentley, a business man of Monongahela, Pa., is erecting a handsome new building which will be used as a moving-picture theatre.

The structure will cost when new more than \$30,000, and will be one of the best theatres in that section where films are shown. The theatre will have a capacity of 400 seats and will be modern in every respect. It will be opened on Thanksgiving Day.

The Regent Theatre in East Liberty, Pa., was opened several days ago and made a hit right from the start. The theatre is a Clark and Rowland one and is built in the most approved fireproof style. It is a model of beauty and one that pleases as soon as one enters the doors.

\$75,000 Theatre Opens in Pittsburgh

The theatre is in an aristocratic section of Pittsburgh and is patronized by the social set of this section. It cost \$75,000 and shows for every dollar spent on its construction.

Among Northern California Houses

The Webster Playograph theatre, Webster street, Alameda, Cal., has been reopened under the management of G. F. Gillelen, having been remodeled and much new equipment installed.

The Theatre Fresno, Fresno, Cal., has been remodeled and has been opened again under the direction of Fred Voight.

The fine new theatre of Eschelbach & Morton at South San Francisco, Cal., was opened on November 14. The house is equipped with two Powers No. 6-A machines and a Wagner converter.

A new house, known as the Crystal theatre, has been opened at Porterville, Cal.

A cement moving picture booth has been built into the Post Theatre, Battle Creek, located on the second floor, taking the place of a galvanized iron booth on the first floor. The new booth is lined with asbestos, and is equipped with two moving picture machines. The following theatres are in course of contemplation in Michigan: G. E. LeVegue, 1717 Dime Bank building, Detroit, plans to erect a brick theatre building on Farnsworth avenue; Architect W. S. Joy, 516 Stevens building, Detroit, is preparing plans for a theatre to cost \$10,000, 50 by 115 feet in size; the United Theatres Company, 322 Monroe avenue, Grand Rapids, will erect a new theatre, and E. N. Brown, who runs a moving picture house on the west side, Grand Rapids, will soon open another at 430 Bridge street, which will seat 600 people.

Fire recently destroyed the Elite moving picture theatre, near Waynesboro, Miss. The property, which was owned by Trigg Bros. & Company, was valued at \$1,500, with no insurance.

George W. Sarlls has just become joint proprietor of the Majestic theatre at Jackson, Miss., by purchasing a half interest in that popular establishment from H. D. Bowers. Mr. Sarlls, who is a native of Indiana, is highway engineer for the county of which Jackson is the seat, and this is his first venture into the motion picture world. He will hereafter devote a good portion of his time and attention to the theatre.

Salamanca, N. Y., is to have a new theatre. J. C. Groat, who has owned and managed several picture houses in the city, has begun the erection of a \$25,000 theatre. The building will be 70 by 140 feet. Under the same roof will also be a ballroom, bowling alleys, billiard room and restaurant. The building is to be completed by February 15, 1915.

Strand, Pasadena, Will Open November 25

THE Strand is to be the name of the beautiful new theatre on Colorado street, Pasadena, Cal., under the management of Jack Root, and the opening date has been set for November 25. The all-star picture, Ethel Barrymore in "The Nightingale," from the Alco program and the Vitagraph spectacular train wreck offering "413," will constitute the opening program.

The REX FILM RENOVATOR

now doing successful work in 25 of the leading Universal, Mutual and Warner Exchanges and more orders to fill.

Mr. Exhibitor, are you getting your service from an exchange that has a Rex Renovator? if not, demand a clean service, regardless of age. Dirty and Rainy film ruins your patrons' eyes and is damaging your business. Hammer at your exchange until you get what you want.

The MIDGET CLEANER and SILENT REWINDER is now ready for the Exhibitor and Small Exchange. Write for booklet on "Creating Good Will," which also instructs how to make a proper film patch and the best film cement Formula. It is free.

Address

Rex Film Renovator Mfg. Co.
272 N. Third Street Columbus, Ohio

We renovate films. Ask for prices.

Make Your Lobby Display Attractive

There is nothing more fascinating to the public than a bright brass frame to display your photos or posters.

We make Lobby and Theatre Fixtures and Brass Rails of every description.

Don't fail to visit our Showrooms. Write for catalog.

THE NEWMAN MFG. CO.
717 Sycamore St., Cincinnati, Ohio
Branch Factories and Show Rooms:
101 Fourth Ave., New York, N. Y.
106-108 W. Lake St., Chicago, Ill.
Established 1882.

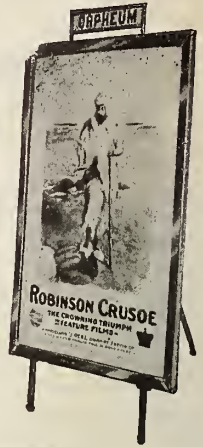

MOVING PICTURE THEATRE MAILING LISTS FOR SALE

20,192, covering United States and Canada, Price \$40.00, or \$3.50 per thousand for such states as you want.

- 795 Film Exchanges, U. S.\$3.50
- 70 Manufacturers and Studios, U. S..... 1.00
- 34 Moving Picture Machine Mfrs. and Dealers.... 1.00
- 231 Film Exchanges, Foreign Countries..... 3.00
- 520 Moving Picture Theatres, Foreign Countries.... 3.00

Ask us for full particulars.

TRADE CIRCULAR ADDRESSING CO.
166 West Adams Street, Chicago
Established 1880

ACCESSORY AID

We stand always ready and willing to help all our readers in making their purchases. We buy nothing but we will tell you where your needs can be supplied to

YOUR BEST ADVANTAGE

Without obligation on my part please tell me where I may purchase the following:

.....

.....

.....

.....

.....

.....

.....

.....

.....

Name

Theatre

Address

PROJECTION PROBLEMS ANSWERED

Troubles are continually coming up in every booth. Why not see whether the other fellow can help you? Our projection expert is ready and willing to answer any and all questions

WHICH YOU MAY ASK

Without obligation on my part please give me full advice on the following:

.....

.....

.....

.....

.....

.....

.....

.....

.....

Name

Theatre

Address

Music and the Picture

Various Ways of Playing the Picture

IN wandering around the city, taking in a picture show here and there, one can hear "music for the picture" played in various ways. One theatre has a "Fotoplayer," another has a "Wurlitzer"; one an orchestra of from three to six pieces, and others just the piano with or without drums.

The Drury Lane theatre on Eighth avenue, New York City, has a "Fotoplayer," and what is more, they have a man that can bring out the good points in it.

The music as rendered on this instrument by this musician is certainly adapted for accompanying the pictures, and the way he can change from one selection to another in keeping with the picture speaks well for the management of this particular theatre.

The Electra theatre on Third avenue, Bay Ridge, Brooklyn, N. Y., has an orchestra of six and a pianist. The cellist there certainly is some player; and in the picture, "The Bond Eternal," where the son comes to the bedside of his mother (the relationship being unknown to him) the audience was held as in a trance by the musician's wonderful playing. There was hardly a dry eye in the house.

This latter is an example of where an orchestra can play for the pictures; but too often there is one selection played after the other in utter disregard of their fitness to the picture. This is where the new "orchestrions," operated from a keyboard, are valuable. Combining all of the advantages and none of the disadvantages of a full orchestra, they have the additional merit of being played by one person, who can change from one musical selection to another, can vary the combination of his different instruments as combined in the orchestration, without any pause or apparent break in the playing, and can therefore suit his music to the picture.

He can change his time, or his selection. He can change from flute and violin to horn and drums and piano or any other combination of instruments as his fancy might dictate; and all this without stopping or hesitating, simply by pressing any combination of stops as on an organ.

Most of these have a separate manual or keyboard on which a solo may be played on any of the instruments, with a piano accompaniment on the other keyboard.

In addition to having the different instruments at the command of one player, to be used in any combination, the orchestrion has all the different "traps" as formerly furnished by the drummer and can bring them in evidence by pressing a button, pulling a leather cord, or pressing a pedal. Drums, snare, bass and kettle; castanets, triangle, tambourine, cymbal, locomotive or steamboat whistle, chimes, horses' hoofs, train bell and so on, are right where he can get them instantly.

Manager-Musician in Charge of Buffalo Hippodrome

THE large audiences at Shea's Hippodrome recently, the enthusiasm which prevailed and the quantities of flowers in the lobby were a flattering testimonial to Manager Shea's appointment of Henry Marcus as the new house manager.

Besides being house manager, he will direct the musical programs, and from time to time will personally conduct the orchestra in selections from the famous composers as well as the latest successes. Mr. Marcus is a musician of artistic cultivation and has had a wide experience as a conductor. He has been until recently the director of the Regent theatre orchestra. For many years he was conductor of Shea's vaudeville house orchestra.

C. W. Perine, manager of the Lyric Theatre at Salem, O., was in Pittsburgh recently and stated that he has just completed remodeling the theatre there. He said business was good. Warner's Features are being used in his house.

Schultz to Direct Music in New Victoria



HERMAN E. SCHULTZ

MRS. LILLIAN M. HASTINGS, at present manager of the Victoria theatre at Grant and East Ferry street, Buffalo, N. Y., announces that she has procured Herman E. Schultz, late director of Shea's theatre orchestra, to take full charge of the music at the New Victoria, when that large and beautiful photoplay house opens in a few weeks.

Mr. Schultz is one of Buffalo's most prominent musicians. He is conductor of the Buffalo Symphony orchestra, a composer of note, and at present furnishes the music at the Hof

Brau, Buffalo's famous German cafe, and the Gayety theatre.

Mrs. Hastings announces that she will have fifteen men in the orchestra at the New Victoria. The theatre will be the second largest in Buffalo, having a seating capacity of over 2,500. It is being built by Mitchell H. Mark, owner of the Strand Theatre, New York. Situated at the corner of Ferry and Grant streets, this theatre will have one of the largest and most densely populated territories in Buffalo to draw upon.

Applications for New Licenses Alarm Minneapolis Exhibitors

IF things keep up at the present rate, Minneapolis will soon have the reputation of having more motion picture theatres than saloons, and it takes some to beat that record.

Three licenses were granted in one day on Plymouth avenue North; two on 20th avenue North; one on 32nd and Penn; one on Lyndale and Lake street; one at 1508 Como avenue S. E., and one at 605 Hennepin, right in the downtown district.

One of the members of the Council remarked that he was in favor of passing every license which might come up, and evidently his word had some bearing on his fellow workers, inasmuch as licenses were granted without any restriction.

This surely is stirring up the exhibitors in local circles, and if things keep up at this rate, Heaven knows what the outcome will be. Something certainly should be done to get the license committee to use some discretion in granting these petitions.

Atlanta Theatre Installs Mirror Screen

Special to MOTION PICTURE NEWS

Atlanta, Ga., Nov. 18.

MANAGER EVANS of the Vaudette has shown his enterprise as an exhibitor by installing a \$1,000 mirror screen last week. Other improvements tell better than words of the prosperity of the Vaudette.

LE COURRIER
Cinematographique
 28 Boulevard St. Denis, Paris
 Directeur: Charles LE FRAPER

Journal hebdomadaire français, le plus important de l'industrie cinématographique.

Envoi numéro spécimen, sur demande

FURNITURE & FURNISHINGS
On RENTAL
 We equip your settings complete in accordance with your scenario.
WILLIAM BIRNS
 103-105 West 37th St.
 Phone: Greeley 6255.

Your negative developed, printed and titled complete
5c delivered per foot within **12** hours
 Titles **6c** per foot
GUNBY BROS., Inc.
 145 West 45th Street New York City

CLASSIFIED

STUDIO TO LEASE
MOTION PICTURE MANUFACTURERS!—We will build a Studio and Film Factory in the Bronx near Biograph Studio and lease to responsible concern for term of years. Buildings fireproof and according to new law. Good opportunity for parties to locate permanently. Address Builder, c/o Motion Picture News.

SITUATION WANTED
PIANIST—First class sight reader and extemporizer wants place. Apply Lunt, Monfort Hotel, West 40th St., New York City.

ROLL TICKETS Specially Printed and Absolutely Guaranteed
 Cash with order. No C. O. D. at these prices.
 50,000 for \$5.40 200,000 for \$15.30
 30,000 for 4.50 100,000 for 9.50
 Write for Samples and Prices on Other Quantities.
 Rees Ticket Co., 400 So. 10th St., Omaha, Neb.

Kinematograph Weekly

\$5.15 a Year

The Leading Motion Picture Publication of Great Britain and Colonies

Sample Copies 10 cents
 For Advertising Rates Write

Associated Moving Picture Press
 250A Kingston Ave., Brooklyn, N. Y.

PLAYER SLIDES

Just what you need, the best made, \$1.75 per dozen. Say Who. There is only one place to get them and that's from the **NIAGARA SLIDE CO.**, Lockport, N. Y.

Putting New Life Into the Balcony

(Continued from page 106.)

are self-lubricating iron wheels which roll up steel tracks. The surface of the moving plane is produced by a series of parallel cleats about one inch apart, forming longitudinal ridges and grooves.

The installation may be either double or single; that is, there may be two escalators running parallel to each other so that one may be moving up while the other goes down, or both in

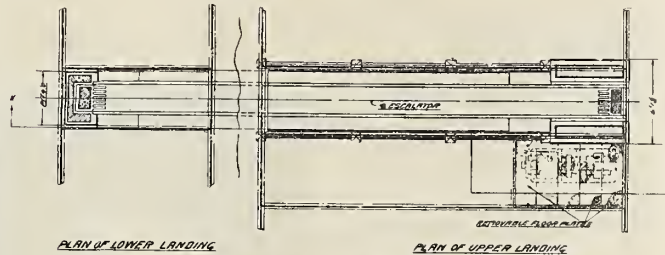

PLAN OF LANDINGS FOR OTIS THEATRE ESCALATORS

the same direction if desired. When running in the opposite directions the descending load counterbalances the ascending with a consequent reduction in power cost.

The accompanying diagrams show the construction details of the

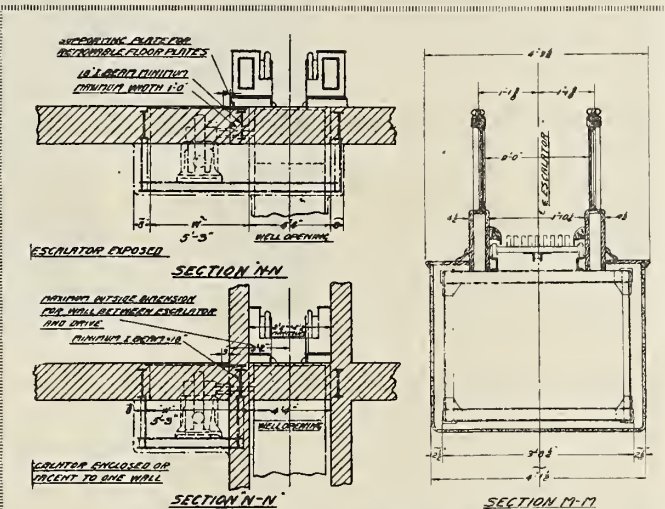

DETAILS OF THE OTIS THEATRE ESCALATOR

the "cleat type" escalator, giving the amount of room occupied, the degree of elevation, and so forth.

The complete installation cost for theatres amounts to \$4,000 as a minimum up to \$10,000, depending upon the finish and extras required. The investment is a good one both for new theatres and those being renovated when the saving in time, space and advance of price is considered.

The question is one worth taking up with your architect and considering if you renovate your present house or are thinking of building a new one. Further information will be given upon request.

"Lucille Love" Is Celebrated in Song

THE Joe Morris Music Company has released a new "moving picture song" entitled "Lucille Love," written by Schurler Green and Otto Motzan of their regular staff. This should be of interest to those seeking "music for the picture."

WE WANT CAMERA MEN
 Who have their own Outfits and can Prove Reliability to write us at once.
INDUSTRIAL MOVING PICTURE CO.
 223 West Erie Street CHICAGO

THIS CANNOT POSSIBLY MEAN ANYTHING TO YOU

If you are not a Live Wire Exhibitor

BECAUSE ACCESSORY NEWS IS BUILT FOR LIVE WIRES ONLY

Read It and See Why

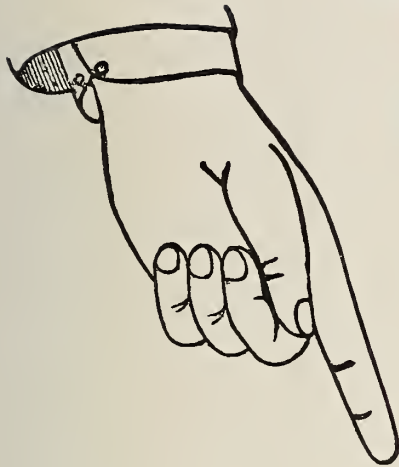

“READ IT!”—

TO ALL EXHIBITORS:—

GENTLEMEN:—

The minute we saw the first release of THE MASTER KEY serial we called in our Poster Artists and gave instructions to spare neither pains nor expense in producing for this remarkable picture the most elaborate 24 sheet poster that money and brains could make, and we say to you candidly, in the entire history of the Moving Picture world we have never yet seen such a work of Art and Power for advertising as this 24 sheet stand.

We have spent a small fortune to have this 24 sheet stand prepared for you. Mr. Laemmle wants YOU to use it. We want every Exhibitor that runs THE MASTER KEY to use it.

It will set your town agog. It will attract people like moths to a flame. Arrange with your local bill poster for as many boards as you can possibly get, then wire your Exchange for all you can possibly use. If you can't get them instantly from your Exchange, wire the MORGAN LITHOGRAPH CO., of Cleveland, Ohio, direct, but *first* go to your Exchange. We have made special arrangements with all Exchanges.

This magnificent 24 sheet stand will bill your house like a circus and what you need and what every living, thinking Exhibitor needs is PUBLICITY and ADVERTISING. This Poster will do the work unlike anything that has ever been attempted in the Movie world. *Wire your Exchange the moment you finish reading this message.*

MORGAN LITHOGRAPH CO.
CLEVELAND, OHIO



—PATHÉ—



MORE THAN QUEEN

A 4-part drama in the superb Pathécolor. The story of a queen who would rather be a woman. The sacrifice of a throne for the perfect love. Perfection in production. Gabrielle Robinne and René Alexandre are featured. 1-3-6-sheet posters.

WHEN FATE WAS KIND

A 3-part American drama. The story of a husband who was betrayed by a friend, yet saved in the eyes of his wife by a strange trick of fate. The unusual in photoplays. 1-3-6-sheet posters.

MAX AND THE FAIR M. D.

Max Linder, funnier than ever, is featured in a 1-reel comedy. He marries a lady doctor but loses his patience while she attends to her patients.

THE PERILS OF PAULINE

Pauline is the modern miracle. She stretches human ingenuity and daring far beyond the ordinary snapping point.

Pauline Keeps a Line Before the Ticket Window.

Exchanges in all the principal cities of the United States

THE ECLECTIC
110 West 40th St.



FILM COMPANY
New York City

"The Cream of American and European Studios"

DECEMBER 5, 1914

Motion Picture News

HAS THE QUALITY CIRCULATION OF THE TRADE

PARAMOUNT PICTURES

JESSE L. LASKY
IN ASSOCIATION WITH
DAVID BELASCO PRESENTS
THE PICTURIZED VERSION OF
THE ROSE of the RANCHO
By DAVID BELASCO AND RICHARD WALTON TULLY
RELEASED NOVEMBER 30TH
JESSE L. LASKY FEATURE PLAY CO.
LONG ACRE THEATRE W. 48TH STREET N.Y.C.

JESSE L. LASKY PRESIDENT
SAMUEL GOLDFISH TREAS. & GEN'L. MANAGER
CECIL B. DE MILLE DIRECTOR GENERAL



ROBERT LEONARD AND ELLA HALL
IN



THE MASTER KEY

by JOHN FLEMING WILSON

*A Thrilling Story of
Mystery and Romance!*

FIFTEEN WEEKS
MOVING PICTURES
UNIVERSAL
THIRTY REELS

MOVING PICTURES
UNIVERSAL



CHARLES FROHMAN
Presents
JOHN EMERSON

In
the recent
theatrical
success,

“THE CONSPIRACY”

By Robert Baker and John Emerson,
A detective comedy-drama
of modern New York,

In Four Parts Released December 10th.

Produced by the

FAMOUS PLAYERS FILM CO

ADOLPH ZUKOR, President,
DANIEL FROHMAN, Managing Director EDWIN S. PORTER, Technical Director
Executive Offices,
213-229 W. 26TH STREET, NEW YORK.





—PATHÉ—



PATHÉ VIEW FROM THE FRONT

Opportunity
Sometimes Knocks More Than Once

THE PATHÉ NEWS

presents an opportunity which knocks twice a week and any wide awake exhibitor may grasp it.

¶ That it is an opportunity worth grasping is best proved by the numbers who grasp it. The Pathé News is today the most widely circulated film in the world.

¶ First in the field of news films, and always leader, its value is doubled today because of the public's white hot interest in the news of current events.

¶ The Pathé News is issued twice a week through the Eclectic Feature Film Exchanges.

¶ Exchanges in all the principal cities of the United States.

THE ECLECTIC
110 W. 40th Street



FILM COMPANY
New York City

"The Cream of American and European Studios"



PATHE

Color Portraits

With Two Sources
of Profit

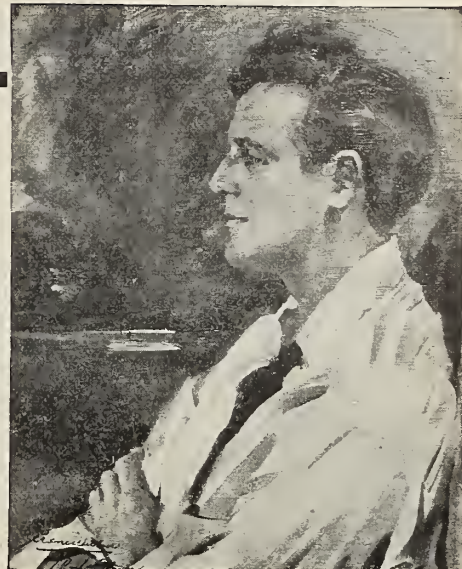

The Pathé reproductions from oil paintings open up a new field to motion picture exhibitors. They are portraits of Pathé's most popular players.

The paintings are reproduced by a new and secret process which retains in detail the full tone, color, richness, and texture of the original.

Sittings were given by Pearl White, Eleanor Woodruff, Crane Wilbur, Paul Panzer, and the artists were the celebrated Goldbeck, Crisp, and Nikolaki. Each picture is a masterpiece in itself, and each was especially selected and approved by the player portrayed. They are autographed by both player and artist.

These reproductions, which cannot be detected from the originals, are produced by the new process at a seemingly incredible price. They are within the reach of every exhibitor and motion picture fan. When framed they are unsurpassed for the lobby of a theatre or for the home.

They have two sources of profit because they increase the popularity of your theatre and add to its distinction and they also create a demand for similar pictures among your patrons. The price to you is so low and the quality of the picture is so high that you can sell them at almost any margin of profit.

The pictures, or information concerning them, may be obtained at any of the Eclectic Feature Film Exchanges, at the home office in New York, or through an exhibitor showing "The Perils of Pauline."

They measure 13 x 17 inches, ready mounted for framing.
Price, \$2.50 each, f.o.b. the Exchange where purchased.

ECLECTIC FEATURE FILM EXCHANGES FOR YOUR USE

- | | |
|---------------------------------------|-------------------------------------|
| ATLANTA
61 Walton St. | NEW YORK
115 E. 23rd St. |
| BOSTON
3 Tremont Row | OMAHA
1312 Farnam St. |
| CHICAGO
5 So. Wabash Ave. | PHILADELPHIA
1235 Vine St. |
| CINCINNATI
217 E. 5th St. | PITTSBURGH
715 Liberty Ave. |
| CLEVELAND
622 Prospect Ave., S. E. | PORTLAND
392 Burnside Ave. |
| DALLAS
Andrews Bldg. | SALT LAKE CITY
68 South Main St. |
| DENVER
Nassau Bldg. | SAN FRANCISCO
67 Turk St. |
| KANSAS CITY
928 Main St. | SEATTLE
810 Third Ave. |
| LOS ANGELES
114 E. 7th St. | ST. LOUIS
3210 Locust St. |
| MINNEAPOLIS
4th and Hennepin Sts. | SYRACUSE
214 E. Fayette St. |
| NEW ORLEANS
910 Gravier St. | WASHINGTON
7th & E Sts., N. W. |

THE ECLECTIC FILM COMPANY

110 West 40th Street, New York City
"The Cream of American and European Studios"



SMASHING SUCCESSES!



"Home, Sweet Home"

GRIFFITH'S HOME SWEET HOME

(Six Reels)
FOR THE HOLIDAYS
BOOK IT NOW

AN IDYL—A SERMON—AN ABSORBING DRAMA
is showing in more theatres to more money than any motion
picture ever produced.

A STUNNINGLY SENSATIONAL FEAT FORMS THE
CLIMAX OF

THE GREAT LEAP

MAE MARSH and ROBERT HARRON are the stars; four
reels is the length and intense drama wonderfully well pre-
sented is the big claim to your attention.

GRIFFITH'S

The BATTLE of the SEXES

in five reels. The vital material would have made eight, but
that isn't Griffith's way. Greatest story of the Double Moral
Standard ever produced or written. It jams theatres.

BOOK IT!

THE WRATH OF THE GODS

SIX SMASHING, THRILLING REELS OF CONCENTRATED
DRAMA PRODUCED BY

THOS. H. INCE

Japanese Story, Japanese Actors, Volcano in Eruption! Filling theatres. It fattens your box office—book it now.



All Mutual
Exchanges

CONTINENTAL FEATURE
29 UNION SQUARE,

STANDING ROOM TRIUMPHS!

BIG DAY SPECIALS

THE MOUNTAIN RAT 4 Reels

A tense vital drama of Western Life

GANGSTERS 4 Reels

Great run at Weber's Theatre, New York. "A great lesson for all."—New York American

RUY BLAS

with William Garwood and
Francelia Billington

THE FLOOR ABOVE

The great Oppenheim mystery
story

FROU FROU

with Maude Fealy, after Augustine
Daly's Production

SAPHO

with Florence Roberts

MOTHS

from Ouida's great novel, a
Thanouser Big Production

DOPE

with Laura Nelson Hall

CARDINAL RICH- ELIEU'S WARD

Florence LaBadie and James
Cruze

ZU ZU

the BAND LEADER, a two reel
Keystone, with Mabel Normand

JOSEPH IN THE LAND OF EGYPT

James Cruze as Joseph, Mar-
guerite Snow as Potiphar's wife

LEGEND OF PRO- VENCE

James Cruze and Maude Fealy

**FOR A WAR
FEATURE DAY
SHOW ONE
OF THESE BIG
SUCCESSSES**

MEXICAN WAR PICTURES

By Special Contract with General Villa

THE DISHONORED MEDAL

With French troops in action

BATTLE OF GETTYSBURG

Greatest War Feature Ever Produced

FILM CORPORATION

NEW YORK CITY

*All Mutual
Exchanges*





MUTUAL PROGRAM THE MAJESTIC MOTION PICTURE CO.

Two part feature release for
SUNDAY, DEC. 6

A QUESTION OF COURAGE

A strong dramatic picture-
story of the civil war

FOUR "GRIFFITH" AND MAJESTIC STARS



Mae Marsh



Lillian Gish



Dorothy Gish



Miriam Cooper

Bromide enlargements of these and other Griffith and Majestic players in all sizes and various new poses can be had for lobby displays at nominal cost by writing to Majestic Studio, 4500 Sunset Boulevard, Los Angeles, Cal.

MAJESTIC AND KOMIC GUIDE FOR EXHIBITORS

(In which we try to tell only the truth about all Majestic and Komic releases)

- ANOTHER CHANCE.** (1 Reel Majestic.) Release date Tuesday, Nov. 24. A melodrama of fair interest and quality, in which an ex-convict is saved from a return to crime by the interference of a crippled newsboy whom he had befriended.
- THE SISTERS.** (2 Reel Majestic.) Release date Sunday, Nov. 29. Featuring Lillian and Dorothy Gish. The story tells of the mutual love and sacrifice of two young mothers under circumstances that will touch the heart-strings of every spectator. Beautifully produced and acted.
- A CORNER IN HATS.** (1 Reel Komic.) Release date Sunday, Nov. 29. A very good farce with a novel idea, showing how much trouble an industrious dog can create.
- THE OLD GOOD-FOR-NOTHING.** (1 Reel Majestic.) Release date Tuesday, Dec. 1. A delightful character comedy drama in which Spottiswoode Aitken plays the part of the lovable old inventor who is thought to be "good-for-nothing," but who finally wins out gloriously.
- A QUESTION OF COURAGE.** (2 Reel Majestic.) Release date Sunday, Dec. 6. A strong, virile picture-drama, reasonably well produced, telling the story of a mother who bravely gave two sons to the war, but rebelled when it came to losing the third son.
- MR. HADLEY'S UNCLE.** (1 Reel Komic.) Release date Sunday, Dec. 6. This is No. 12 of the famous "Bill" stories by Paul West, published in 20 Sunday newspapers in the larger cities. It is an excellent number.

MAJESTIC MOTION PICTURE COMPANY

Studios: 4500 Sunset Blvd.
Los Angeles, Calif.

Business Offices, 29 Union Sq. W.
New York City.



ABOVE ALL QUALITY

MUTUAL PROGRAM

STATE RIGHTS

ON WHAT ARE CONSIDERED THE GREATEST MASTERPIECES EVER PRODUCED. AN OPPORTUNITY TO GET THE BEST RELEASES ON THE MARKET FOR A STATE RIGHTS PROPOSITION—ADVERTISING PROPS AND SPECIAL MATERIAL ALL READY TO WORK WITH. TERRITORIES OPEN INCLUDE BEST IN THE COUNTRY.

THE ESCAPE

THIS REMARKABLE SEVEN REEL D. W. GRIFFITHS PRODUCTION WILL GET THE MONEY FOR YOU FOR YEARS TO COME. IT IS A STRONG COMPELLING DRAMA TREATING ON A SUBJECT THAT WILL NEVER GROW OLD. THE MASTER HAND OF GRIFFITHS IS SEEN ALL THROUGH THE PRODUCTION AND THE COMPELLING DRAMATIC ACTION WILL FILL ANY AUDIENCE WITH AWE.

THE AVENGING CONSCIENCE

IS AN ADAPTATION OF EDGAR ALLEN POE'S GREAT MASTERPIECE "THE TELLTALE HEART." D. W. GRIFFITHS HAS POSITIVELY REPRODUCED ALL THE SUBTLE, WEIRD EFFECTS AND WONDERFUL DRAMATIC CLIMAXES FOR WHICH POE IS NOTED. THIS SIX REEL PRODUCTION CAN BE RENTED NOT ONLY FOR TODAY AND TOMORROW, BUT WILL LIVE FOREVER. EVERY POSSIBLE ADVERTISING PROP IS READY ON THIS MASTER PHOTO PLAY. A SPECIAL PROPOSITION WILL BE GIVEN TO STATE RIGHTS BUYERS TAKING BOTH SUBJECTS.

SEND AT ONCE FOR FULL PARTICULARS, PRICES, AND TERRITORY OPEN

WESTERN IMPORT CO.
71 WEST 23rd STREET, N.Y.

A Page from the Book of Life

RUNAWAY JUNE

BY
GEORGE RANDOLPH CHESTER
 AND
LILLIAN CHESTER

☐ RUNAWAY JUNE was written for the screen. It is the first serial series ever written solely and entirely with this end in view. It is not a story just written and adapted to the screen, but it was written on order for us. ❀

☐ RUNAWAY JUNE deals with money, gold, love, romance, jealousy, hatred, mystery, a woman, a man—it deals with the drama of life. Yet through it all is a fine vein of comedy.

☐ Will be published in 2500 leading newspapers throughout the United States and Canada. ❀ ❀ ❀

☐ RUNAWAY JUNE will start where all other pictures end. It leads off with a wedding. The greatest and most expensive wedding ever shown on the screen. ❀ ❀ ❀ ❀ ❀

☐ RUNAWAY JUNE has action, suspense, dramatic punch, photography, direction, and last but not least the greatest story ever told on the screen.

CL RUNAWAY JUNE will be without a doubt the greatest serial ever released. There will never be one better.

CL RUNAWAY JUNE will get the money for you no matter what program you are using. You will play to capacity when you show it. It runs for fifteen weeks, two reels a week. We want every exhibitor in the country to write to us for our advertising booklet—the greatest help to exhibitors ever put out. A fifteen weeks' campaign all laid out for you by the greatest advertising force in the country. ❀

CL RUNAWAY JUNE is being produced by the Reliance Motion Picture Company, 29 Union Square, New York City, and can be had at any Mutual Exchange. ❀ ❀ ❀ ❀ ❀ ❀ ❀

CL RUNAWAY JUNE is a lesson. It is the problem of life. The rich, the poor, the working man and the millionaire are all interested in the problem that it offers. ❀ ❀ ❀ ❀ ❀ ❀ ❀

CL RUNAWAY JUNE is not a "stunt" picture—not a chase picture—not a lot of situations thrown together in a haphazard way. ❀ ❀ ❀ ❀ ❀ ❀ ❀

CL RUNAWAY JUNE means something more than just picture. George Randolph Chester has put his heart and soul into it. It is his greatest work. It is so good that he is willing to have his wife's name, Lillian Chester, associated with him in it. ❀ ❀ ❀ ❀ ❀ ❀ ❀

See Americans First
FLYING "A" and AMERICAN "BEAUTY"
FEATURE FILMS



"OUT OF THE DARKNESS"

A Two Act Psychological Drama. Tense and Thrilling.

Featuring VIVIAN RICH and WM. GARWOOD. Under direction
of Thos. Ricketts.

Release Monday, December 7th, 1914

AMERICAN "BEAUTY" FILMS "LIMPING TO HAPPINESS"

A Dainty Comedy Farce

Release Tuesday, December 8th, 1914

"THE GIRL IN QUESTION"

A Modern Society Drama depicting a Mother's Strategy

Release Wednesday, December 9th, 1914



Distributed exclusively through the United States and Canada by the
Mutual Film Corporation

AMERICAN FILM MFG. CO.
CHICAGO



?

DO YOU BELIEVE IN THE MAGIC OF NAMES

A magnet that never fails to attract the public.

Look them over—EDMUND BREESE in "THE WALLS OF JERICHO," DOROTHY DONNELLY in "THE THIEF," CHARLES RICHMAN and CATHRINE COUNTISS in "THE IDLER," WILLIAM FARNUM in "SAMSON," the modern play of frenzied finance; WILTON LACKAYE in "THE CHILDREN OF THE GHETTO," EDWARD JOSE in "A FOOL THERE WAS," and ROBERT EDESON in "THE GIRL I LEFT BEHIND ME."

THE MOST BRILLIANT ASSEMBLAGE OF STARS ever aligned under a motion picture trademark. Names known in every city, town and village. We have the "PICTURES," Mr. Exhibitor. Now it's up to you!

NOW BOOKING THE WALLS OF JERICHO

With

EDMUND BREESE

As produced by James K. Hackett at the Hackett Theatre, New York.
A master production by one of England's greatest playwrights.

ALFRED SUTRO

A modern story of the frivolities of the smart set.

BOX OFFICE ATTRACTION COMPANY

WILLIAM FOX, President

Executive Offices: 130 West 46th Street, New York City

NEW YORK CITY, N. Y.—126 W. 46th St. Phone: Bryant 7340.
WASHINGTON, D. C.—434 Ninth St., N. W. Phone: Main 1426.
BOSTON, MASS.—10-12 Piedmont St. Phone: Oxford 6254.
SYRACUSE, N. Y.—400 Eckel Theatre Bldg. Phone: Warren 119.
PHILADELPHIA, PA.—1333 Vine St. Phone: Walnut 4503.
PITTSBURGH, PA.—121 Fourth Ave. Phone: Court 1302.
CLEVELAND, O.—618 Columbia Bldg. Phone: Cuyahoga Central 6260R.
Bell: Main 5677.

ST. LOUIS, MO.—3632 Olive St. Phone: Bell: Lindel 795; Kinloch: Delmar 7253.
KANSAS CITY, MO.—928 Main St. Phone: Bell: Main, 1008; Home: Main 7253.
DALLAS, TEX.—1907 Commerce St. Phone: South Western: Main 2066.
SAN FRANCISCO, CAL.—107 Golden Gate Ave. Phone: 4880 Market.
DENVER, COLO.—Ideal Bldg., 17th and Champa Sts. Phone: Main 5071.
MINNEAPOLIS, MINN.—Jewelers' Exchange Bldg. Phone: North Western
Nicollet, 2498.
CHICAGO, ILL.—314 Mallery Bldg., 5 S. Wabash Ave. Phone: Central 1718.
SEATTLE, WASH.—1214 Third Ave. Phone: Elliott 1039.



Ella Wheeler Wilcox

whose genius produced the famous poem upon which is based the wonderful 5-part drama *The PRICE HE PAID*



"Folks talk
too much of
a soul
From heaven-
ly joys de-
barred--
And not e-
nough of the
babes unborn,
By the sins
of their fa-
thers
scarred."



UNITED FILM SERVICE (WARNER'S FEATURES, INC.) N.Y.

The PRICE HE PAID

Greatest feature *of the year*
by
Ella Wheeler Wilcox



THE VICTIM

THE GRANDMOTHER

THE OTHER GIRL

THE DOCTOR

THE ARTIST

The most powerful and stirring appeal ever made by a photoplay is that of "The Price He Paid". It plays on the heart-strings with a master touch. It tells a story replete with life and action and human interest. And what is more---it teaches a big, broad lesson. Book it now from your nearest United (Warner's) Exchange.

UNITED FILM SERVICE (WARNER'S FEATURES, INC.) N.Y.

THE WOLF'S PREY

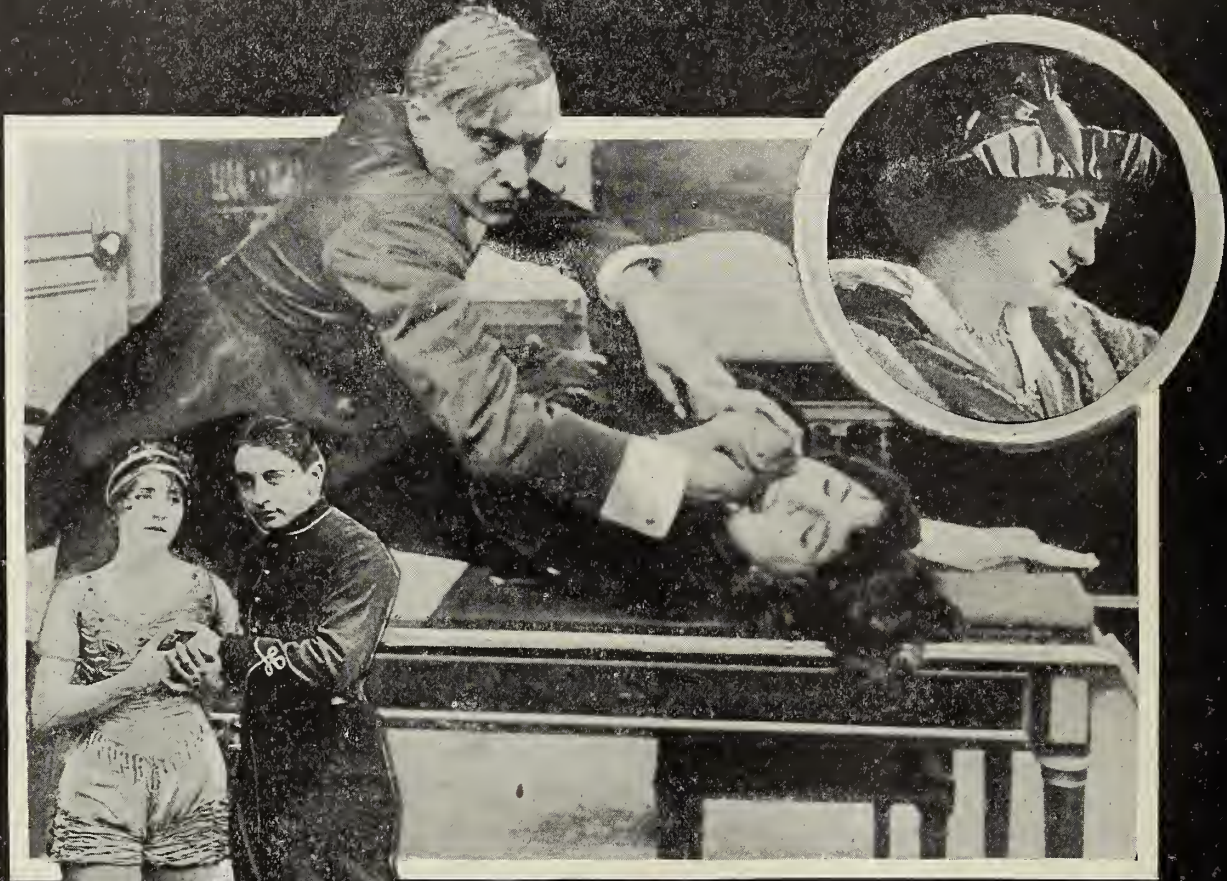

*A bold adventuress and
her wily accomplice tan-
gle the skein of three lives
A great story splendidly acted and
perfectly staged. Three parts.*

FOR THE MOST PROGRESSIVE SINGLE & MULTIPLE REEL
SERVICE WRITE YOUR NEAREST UNITED (WARNER'S) EXCHANGE

UNITED FILM SERVICE (WARNER'S FEATURES INC) N.Y.



On Getting Down to "Brass Tacks"



The trouble the Humanology Film Producing Company experienced in finding a releasing firm with a really sound business-like proposition is thus described by Jack Rose, president of the company, in the New York Sunday Telegraph of Nov. 1:

will be a... appear that with them far above the average lurid depiction of slum life with which the picture show patrons have become familiar.

Rose has spent several weeks in New York with the object of contracting with a service firm for the marketing of his films. After consultation with the heads of the various New York booking concerns, he closed a contract with the United Film Service, which, aside from supplying the well known Warner's Feature Films, now furnishes complete daily change-of-programme service to leading photo-play houses throughout the country.

"I've had my troubles in securing the right outlet for my productions," said Rose. "The propositions made me sounded good until matters got down to brass tacks, and then there was little left but a labyrinth of wasted verbiage. Very much discouraged, I heard of the United Film Service. I opened negotiations and found all the good words I had heard of this firm substantiated. I am satisfied that in entrusting the marketing of my films to the United Film Service I am insuring them the best possible exploitation."

Mrs. Wilcox, now that she has been won over to the motion picture fold, was pre-... to... late how it all came about...

P
D
M
T
was
ditio
reme
adv
var
oth
"that
cha
Tem
tho
th
ou
M
Ar
a
t
on
stand
solve
"T
Lin
gra
"Hu
prop
for

UNITED FILM SERVICE (Warner's Features, Inc.) New York



*Florence La Badie—the world's most famous
motion picture player—A Thanhouser Star*

THE popularity of Thanhouser productions is due to the remarkable strength of the Thanhouser organization. In regular Thanhouser releases you will find such stars as Florence La Badie and Sidney Bracy who made famous *The Million Dollar Mystery*.

The overwhelming success of *The Million Dollar Mystery* demonstrates the ability of the Thanhouser Film Corporation as a producer of high quality photoplays.

The Thanhouser Film Corporation releases three productions every week through the Mutual Film Corporation in the United States and Canada. Exhibitors can arrange bookings in America through the nearest Mutual Exchange.

For the current week we announce these three releases:
Tues., Dec. 1st. "The Center of the Web." A two-reel drama including Claire Kroell and Frank Wood.
Fri., Dec. 4th. "Naidra the Dream Woman." A drama cleverly enacted by Riley Chamberlain, Mignon Anderson, Morris Foster and Carey L. Hastings. **Sun., Dec. 6th.**
 "The Amateur Detective." A drama with Carey L. Hastings and Muriel Ostriche.

Thanhouser Film Corporation

New Rochelle, New York



THE PRODUCTIONS OF

<p>FAMOUS PLAYERS FILM CO</p> <p>In Association with Daniel Frohman Chas. Frohman-Henry W. Savage</p>	<p>JESSE L. LASKY FEATURE PLAY CO</p> <p>Associated with David Belasco The Liebler Company</p>	<p>BOSWORTH INC.</p> <p>Affiliated with Oliver Morosco Photoplay Company</p>
<p>CONSTITUTE</p> <p><i>Paramount Pictures</i></p>		

THE PARAMOUNT SCREEN

shows the greatest aggregation of talent and stars ever released through one concern.

Paramount Program has now been augmented by the affiliation of the Bosworth Company with the distinguished theatrical producers, Oliver Morosco and John Cort.

Have you thought about Paramount Service and what it means to the exhibitor?

If not, write our nearest exchange for information.

Paramount Pictures Corporation
 ONE HUNDRED and TEN WEST FORTIETH STREET
 NEW YORK, N. Y.



V. TROTTA

A Phenomenal Success!

ZUDORA

Thanhouser's Greatest Photoplay

The first episode of Zudora was released Nov. 23rd. The tremendous enthusiasm that greeted Episode No. 1 at the theatres in New York, Chicago and in other cities throughout America stamps this newest Thanhouser production a *phenomenal* success.

It is only natural that a photoplay created and written by two such noted authors as Harold MacGrath and Daniel Carson Goodman, should meet with pronounced success. This stupendous serial is now running at the better theatres. The story is appearing in the biggest metropolitan newspapers. Such wonderful cooperation and a play of extraordinary merit have made this Thanhouser's **GREATEST** Photoplay.

An exceptional cast including Marguerite Snow, Harry Benham and James Cruze interpret this play with all the effects which the authors intended. The entire production will take 20 episodes of 2 reels each. A new episode is being released each week. Exhibitors who are seeking a powerful box office attraction can arrange Zudora bookings by applying to the Thanhouser-Syndicate representative at any Mutual Exchange in America. Zudora is an independant release and may be obtained regardless of the regular program being used. Book NOW!

207



Trade Mark Registered.

Thanhouser Syndicate Corporation

71 West 23rd Street, New York

*Produced by Thanhouser Film Corporation, New Rochelle, N. Y.
Producers of The Million Dollar Mystery.*

207



Trade Mark Registered

"When You See It
In 'The News'
It's NEWS"

Motion Picture News

HAS THE QUALITY CIRCULATION OF THE TRADE

"The Exhibitors"
Medium of
Communication"

TEL. 7650 BRYANT

TWO HUNDRED AND TWENTY WEST FORTY-SECOND STREET

NEW YORK CITY

Volume X

DECEMBER 5, 1914

Number 22

What's the Matter?

IT is no secret that the picture market is at present in considerable disorder. It is confused—to say the least.

Those who are in close touch with field conditions—particularly those in touch with *exhibitor* conditions—realize this fact very clearly.

* * *

WITHIN the week past I have put the question to a number of leading manufacturers: "What is the matter?" Where is the trouble spot—if there is one main spot?

Their replies are remarkably at variance.

There is one common attitude of mind—and that is a real desire to know *what is wrong*. A few are trying urgently to find out.

* * *

ONE manufacturer is a pessimist.

Few exhibitors, he declares, are making money.

The manufacturer is in the same boat.

For which condition, he says, there is one main cause, namely, unbridled competition—*all along the line*.

"There are," he asserts, "an over-production, an over-distribution, and an over-exhibition of pictures.

"There are twice too many houses," he continued.

"If you tallied their number of seats, assessed each its necessary earning capacity, the result would profoundly amaze you.

"Again, pro-rate the number of exchanges to the number of theatres and you'll find the average exchange can't possibly make expenses."

At the same time he admits—and the admission is significant—that there are too few exhibitors who really know their business, too few efficient and successful exchange managers, and a lot of producers who don't know how to make good pictures, nor to make them without exorbitant waste.

* * *

ANOTHER manufacturer believes in efficient distribution.

The business is to be had, he says, and will be had through exchanges systematized along modern efficiency lines and raised to highest endeavor through a profit-sharing scheme on increased business.

But he also makes an admission—that this increase of business is to come to him directly from the exhibitor, who therefore must have an increase from the public, *which increase will only come steadily from good pictures, successfully advertised and exhibited*.

* * *

IN other words, he must do a good deal for the exhibitor in the way of pictures *and service* (advertising help,

principally) if his efficient exchanges are to do a good deal for him and for themselves.

* * *

A FEATURE manufacturer puts his finger definitely on one trouble spot, when he says that picture theatres today are in a state of hopeless and confused competition *because they are not standardized*.

In the legitimate, vaudeville and burlesque fields, theatres are well separated into distinct groups.

There is a wide variance in the cost and quality of their bills and correspondingly in the prices of admission.

But in the picture theatre field, with little range in admission price, big and little houses are scrambling all over each other in an effort to compete with much the same kind of bills.

* * *

"I AM booking features every day," said he, "to exhibitors who, with their limited number of seats and low admission price, can't possibly afford them. At least they are losing money on them."

This brings us to the question of increased prices, which another manufacturer is now prominently advocating.

But here again exceptions must be made.

Increased prices are highly necessary and logical—there is no question about that; moreover they are inevitable.

But you cannot simply *tell* the exhibitor to raise his admission price: you must tell him *how* to do it successfully.

To please the public and make it pay more he has got to have *good pictures, good music and good all around theatre service*; and secondly, *and very importantly*, he must advertise efficiently.

There is a great deal to tell him on these points, a great deal of help to give him, which he wants badly and greatly deserves.

Again, prices will not be raised, on a scale at all general, until the exhibitors are organized.

* * *

THE fundamental spirit of the human race is a fighting one.

It's sad, but it's true; and the European situation today isn't the only glaring example.

We fight much more easily than we reason; and this applies to the whole world in its daily affairs.

Senseless, cut-throat competition exists among exhibitors today simply because they don't know each other and won't become acquainted and reasonable.

They "see red" and start to kill each other off; whereas a conference would probably disclose, first, that each combatant was a pretty good sort and, secondly, that there was enough local business, properly increased and divided, to make each fairly prosperous, instead of bankrupt.

TO recount, then, we may say that the following "wrongs" exist, in more or less degree and sufficiently to bear seriously upon the situation.

There are over-production, over-distribution and over-exhibition of pictures—the normal results of a big, fast-growing industry.

But against these conditions, there are also: generally wasteful production and a good deal of *poor* production; a good deal of wasteful distribution; a large measure of faulty exhibition due principally to confused buying policies, poor house service and inefficient advertising.

In other words, while there is an *over-development* in volume of business, there is an under-development in *efficiency*—all along the line.

And coupled with this situation there are: a lack of standardization among theatres and of organization among exhibitors.

* * *

WHAT is to be done?

Obviously a great many things: but is there any one way to start to put the house in order?

I have purposely delayed one interview because it seems to me that this manufacturer answers the situation. He does so in one word: education.

We all need it, he says; and we need a consistent campaign of it.

It will do little good to generalize and theorize.

We must have concrete facts—details of field conditions and practical suggestions, for the exhibitor and exchange, of how to meet them. Complete data should be secured and presented.

* * *

THIS man believes in the better motion picture and the greater motion picture future.

Several million more people, the more cultured classes, can be—many are being—made regular patrons of the picture theatre.

But to meet the requirements of this greater field and to cope with the exactions of the present great one, we must make ourselves fit and efficient.

* * *

HE doesn't believe that a trade journal can afford to print such articles: but we do.

We believe they will be received in the spirit of fairness with which they will be presented and for the sake of the industry upon which we are all dependent.

At least, we are going to try it. We shall announce these articles shortly.

WILLIAM A. JOHNSTON.

EXCHANGEMEN AND EXHIBITORS LAUNCH PITTSBURGH SCREEN CLUB

Special to MOTION PICTURE NEWS

Pittsburgh, Nov. 25.

THE Pittsburgh Screen Club was formed at the meeting and banquet held last Sunday at the Fort Pitt Hotel in this city, with more than 300 persons attending the opening meeting. It was the greatest gathering of the film men of this section ever held and it is certain that the greatest good possible will be accomplished by the new organization, if the initial gathering has anything to do with its future.

Men of political and civic prominence gathered about the banquet table and assisted materially with the work of organization and State Representative A. C. Stein, who is one of our prominent local attorneys, offered the boys to get them the charter free so that they can get going right as fast as possible.

There was a spirited but friendly gathering of the film men on one side and the exhibitors on the other and politics was played to the limit with the result that the exhibitors proved their strength when they elected to the presidency of the organization H. B. Kester of the East Liberty Cameraphone Theatre.

One word about Kester. He is one of the prominent exhibitors in this section and has a host of friends. He ranks high as a man and is one of the best men that could have been selected from the ranks for the position of president of the new organization. He is a hustler as an exhibitor and as a booster for the film business he is one of its best workers.

William Mayer was elected secretary. He is the publisher of the "Pittsburg Moving Picture Bulletin," a paper that at all times pushed the interests of the film men here. He was elected secretary without any opposition and is sure to prove his worth when it comes to advancing the interests of the business here.

A. J. Hanna, of the Palace Theatre, was elected treasurer. He has been connected with other movie organizations here and is well liked by all the boys who know him.

There were exhibitors from all over the western part of Pennsylvania, West Virginia and Eastern Ohio, and they were all loud in their praise for the getting together of the banqueters for the formation of the Screen Club.

From the amount of interest taken by all present the Screen Club has a bright outlook before it and it is sure to be an organization for the betterment of the business here. It also has for an object of organization, protection of the business from the claws of a few politicians who would bleed the business for the last cent to pay the debts of hot political campaigns.

There is a large amount of work before the members as there are several bills pending in the legislature at Harrisburg that might spell ruin to many of the small exhibitors in the state and it is to the interests of these men that the screen club will look as well as to those of the larger theatres.

G. L. McCoy, Jr.

INDIANA EXCHANGES JUMP RENTAL PRICES

Special to MOTION PICTURE NEWS

Evansville, Ind., Nov. 25.

NOTICE has been served on movie theatre managers by local film exchanges that the cost of films will be increased forty per cent. by the first of December. Those picture shows that have been paying a weekly rental of \$60 will have to pay \$100.

The cause of the increase is said to be the war in Europe. Chemicals used in the manufacture of films which come from Europe cannot now be obtained. The supply now in the United States is said to be fast diminishing.

Managers are also preparing to make their first annual war tax payment on December 1. The schedule of taxes is as follows: seating capacity of 250, \$25; 250 to 500, \$50; 500 to 800, \$75; all over 800, \$100.

HORKHEIMER IN NEW YORK WITH 40,000 FEET OF NEGATIVE

Special to MOTION PICTURE NEWS

E. D. HORKHEIMER, secretary and treasurer of the Balboa Amusement Producing Company, of Long Beach, left the early part of last week for New York City, taking with him 40,000 feet of Balboa Feature negative which he will deliver to a great marketing corporation, recently formed to handle the products of this company.

While in the East Mr. Horkheimer will arrange further details regarding the Balboa series of pictures dealing with problems of today, for which the company will give \$1,000 in prizes for the best letters answering the query, "Who pays?" It has been announced that there will be twelve separate releases, each complete within itself.

A renewal of the contract with Bishop, Pessers & Co., Ltd., of London, for marketing Balboa pictures in Europe will be consummated by Mr. Horkheimer and Mr. Henry Pessers, who is now in New York, having made a special trip across the Atlantic for the purpose of making this contract.

The London firm, by the terms of the new contract, will have charge of marketing all Balboa pictures in India, Australia, South Africa and other foreign lands.

K. C. BOOKING COMPANY OPENS CANADIAN OFFICES

THE K. C. Booking Company, Limited, has been formed and has opened offices in Montreal, Canada. The company will handle all of the Kinetophote features in Canada, including such Kinetophote masterpieces as "The Spirit of the Poppy," "The Span of Life," "The Coming Power" and others.

"Markia," or "The Destruction of Carthage," the Ambrosio production which the Kinetophote owns, will also be booked.

WHERE EXHIBITORS STAND UNDER THE WAR TAX

Motion Picture Houses Will Be Assessed the Same Amounts as "Legitimate" Theatres, According to the Decision of the Assistant Commissioner of Internal Revenue—Transfer of a Lease Not Allowed to Include Tax Payment—Government Scrutinizing Imported Films

Special to MOTION PICTURE NEWS

Washington, D. C., Nov. 25.

MOTION picture theatres will be considered in the same light as the legitimate houses in the assessment of the special tax under the provisions of the act to increase the internal revenue recently passed by Congress, according to a statement contained in a letter addressed to the collector of the eleventh district in Columbus, Ohio, by the assistant commissioner of internal revenue. This decision was arrived at after the matter had been given careful consideration in the commissioner's office.

In a letter addressed to the collectors of internal revenue, Commissioner W. H. Osborn states: "Every person, firm, or company liable to special tax under the act of October 22, 1914, should render a return and pay such special tax, as provided in the case of other special-tax payers. As these special taxes take effect from November 1, 1914, all such returns and payments, for the remaining portion of the special tax year ending June 30, 1915, should be made during the present month or within the month in which the business is subsequently commenced."

The commissioner further states that such returns (applicable to theatres) should be made on Special Form 11A, which will be furnished to collectors at an early date, and in a note appended to the letter the fact is emphasized that returns must be made during the current month.

In the event that blank forms for returns are not received in time for persons to make return within the calendar month thereon, parties requesting the same are to be instructed to make a statement or return of liability on a plain paper, which will be received as a tentative return, and the party making same will thus be relieved from any liability to the penalty of 50 per cent., in addition to the amount of the tax for delinquency.

What the Law Says

Section 6, of the law, which relates to theatres, is as follows:

"Sixth. Proprietors of theatres, museums and concert halls, where a charge for admission is made, having a seating capacity of not more than two hundred and fifty, shall pay \$25; having a seating capacity of more than two hundred and fifty and not exceeding five hundred, shall pay \$50; having a seating capacity exceeding five hundred and not exceeding eight hundred, shall pay \$75; having a seating capacity of more than eight hundred, shall pay \$100.

"Every edifice used for the purpose of dramatic or operatic or other representations, plays or performances, for admission to which entrance money is received, not including halls or armories rented or used occasionally for concerts

or theatrical representations, shall be regarded as a theatre: Provided, That whenever any such edifice is under lease at the passage of this act, the tax shall be paid by the lessee, unless otherwise stipulated between the parties to said lease."

Exceptions to this clause are taken when "theatres are entirely closed to performances during the months of July and August, and only open in the month of September, the special tax is to be

the District of Columbia, although but one tax will be collected for exhibitions within any one of these.

Included in this provision are exhibitions and shows given on fair grounds, but not under management of the fair association; lecturers using a stereopticon to illustrate their lectures, and charging an admission fee.

Watching Imported Films

Instructions have been given to all officers and collectors of the customs to carefully examine into the origin of all motion picture films offered for free entry into the United States from abroad, it having come to the attention of the customs division that in many instances moving picture films have been entered free of duty as of American origin when they were in fact manufactured abroad from negatives exported from the United States.

In a letter to the officials of the customs service, Andrew J. Peters, assistant secretary of the treasury and chief of the division of customs, states:

"From statements made by leading film manufacturers in the United States it is learned that in most cases no positive prints are shipped abroad. The negatives only being shipped and the positives made in Europe. In cases where positive prints are shipped to Europe, they are leased or sold with the understanding that the films are not to be resold or shipped back to the United States.

"In view of the foregoing, you are instructed to examine carefully all moving picture films claimed to be free of duty under paragraph 404 of the tariff act and to refuse free entry in case of doubt unless satisfactory evidence shall be produced as to the American origin of the film. In cases where films of foreign origin are fraudulently invoiced as of American manufacture, they will be released only upon payment of the home value therefor plus the duty."

EARLE A. DYER.

WHERE TO FIND IT

Department.	Page.
Live Wire Exhibitors.....	27
In and Out of Los Angeles Studios	29
Looking Ahead	33
Editorials	35
Among the Exchanges.....	37
Exhibitors' Forum	39
Feature Reviews	41-45
Program Reviews	47-49
Buyers' Guide	54
Current and Coming Releases..	52, 53
Release Dates for Ready Reference	55-57
ACCESSORY NEWS.....	103-116

recorded from the first day of September to the first day of July following, at the rate of \$100 for the year beginning July 1. (Nov. 1, 1914, to June 30, 1915, current year.)

"A special tax stamp taken out by the lessees of a theatre cannot, upon their transferring their lease to other persons, be transferred and made to answer for the latter persons in conducting the theatre."

Proprietors or agents of certain other public exhibitions, not including circuses, or shows for money, shall pay \$10, and this tax paid in the District of Columbia, one State or Territory, will not exempt from payment of a like amount in another State, Territory, or

Only Woman Member of National League

Mrs. Charles Marley, of Los Angeles Branch, Said to Have Such Distinction—Thirteen New Members Recently Enrolled

Special to MOTION PICTURE NEWS

Los Angeles, Nov. 23.

THE League workers in Los Angeles have met with great success. The names of thirteen new members were recently enrolled, the "class" being composed of the following: George A. Howell, Lyric; Bert Lustic, National; Dick Parks, Photoplay No. 1; Seth D. Perkins, New Optic; Manager Sweeney, Novclty; I. Gore, Electric; Fred Seigert, Columbia; F. H. Lowe, Majestic, Glendale; Manager Campbell, Banner; S. U. Anderson, Belvidere, Pamona, and Mrs. Charles Marley,

Liberty. The League officers expect a still greater increase.

With these new members the membership totals about forty, but it is the plan of every member to keep up the good work and eventually have every exhibitor a member.

Securing the membership of Mrs. Charles Marley, the officers believe, brings the distinction to the Los Angeles League of having the first woman member of any organization affiliated with the National League. But then why not? This is one of the first states to adopt equal suffrage.

PATHE TAKES WAR FILMS WITH OFFICIAL SANCTION

It has been officially announced that Pathe Freres has been appointed official cinematographers to the French Government in connection with the war. This much sought for concession will give Pathe a tremendous advantage in the matter of securing authentic and historically valuable pictures of the world's greatest conflict, since it is evident that the prejudice which has existed against the motion picture camera anywhere near the firing line will, to some degree, be lessened when the cameraman bears an official government commission.

In this connection, Pathe Freres announces that the reported arrangement between a branch of theirs in Germany and the German Government for the taking of war pictures with official sanction, is untrue. Such an arrangement they say may have been made with a German film company but certainly not with any connection of theirs.

"CHRISTIAN" WELL HANDLED IN ILLINOIS

Exhibitors throughout Illinois have been favorably attracted by the manner in which The W. H. Bell Feature Film Corporation has been handling their feature film, "The Christian," produced by the Vitagraph-Liebler Company.

The picture is handled and routed along the lines of a road show. Particularly attention is given to the supplying of music cues, elaborate big framed lobby display, valuable publicity aids and effective paper in connection with the distribution of this subject.

"DAMON AND PYTHIAS" TO BE SEEN AT NEW YORK THEATRE

On Monday, November 30, at the New York Theatre, New York, the Universal Company will make the initial presentation of its newest and most costly feature film, "Damon and Pythias," and two performances will be given daily throughout the engagement. Such an important picture will attract attention.

California League Adds Thirty Members

Organizer Cory, on a Thorough Canvass of the State, Sends in Batches of New Names Practically Every Day

Special to MOTION PICTURE NEWS

San Francisco, Nov. 16, SINCE the annual convention of the Motion Picture Exhibitors League, of California, which was held in San Francisco one month ago, more than thirty new members have been added to that organization and scarcely a day passes but what new additions to the list are made by the secretary and organizer, W. A. Cory, who is now in the field visiting exhibitors.

Mr. Cory left San Francisco by automobile on October 28, and when last heard from had reached Los Angeles, where he expects to secure fifty or more new members. Among the houses in the coast section that have been brought into the state organization by the organizer on his present trip are the following:

Liberty Theatre, San José; Gem Theatre, Los Gatos; Jewel and Star Theatres, Santa Cruz; White's Theatre, Salinas; Bagby Theatre, Monterey; Star and Monterey

Theatres, Monterey; Novelty Theatre, Soledad; W. H. Farley, Pacific Grove; Elmo Theatre, San Luis Obispo, and Dixon Theatre, Ventura.

Other houses that have joined since the convention are the Colonial, Oakland; the Princess, Oakland; the Elite, San Rafael; Wonderland, Turlock; Fairyland, Willows; Lyceum and Modesto, Modesto; Sunset, Fowler; P. S. Braun, Monte Rio, and H. D. Hubbard, Calistoga.

Most of these houses are located in small cities on the coast and in the interior, and indicate in a striking fashion the feeling among country exhibitors of the need of organized effort. As the time for the opening of the biennial session of the state legislature draws near, it is becoming apparent that many measures of more than ordinary importance to the moving picture industry will be introduced and exhibitors are determined to be prepared to combat any adverse legislation.

Milwaukee Exhibitors Prepare Ball In January

Preliminary Work Well Under Way—Profits Will Be Devoted to Legislative Fight—Trade Exhibition Will Again Be a Feature

Special to MOTION PICTURE NEWS

Milwaukee, Nov. 25.

THE motion picture ball, which is to be given by the Milwaukee Motion Picture Exhibitors' Association, will be held under the auspices of the newly organized Wisconsin Photoplay Association, which organization will utilize the profits to battle adverse legislation at the state capital. Much of the preparatory work for the ball, which will be given in January, has been started.

An attempt will be made to get just as many photoplay stars as possible to attend the dance, and letters inviting the various companies to send their stars were sent out.

In addition to the ball, it was decided to hold a trade exhibition, the same as last

year, only on a much larger scale. A space for a picture theatre was arranged and a free show will be run all during the dance and exhibition. A cabaret entertainment will also be on the program, the songs going on between dances. J. W. MARTIN.

AUTHORITIES HELP FILMING OF "SPRINGTIME"

The municipal authorities in New Orleans have afforded the Life Photo Film Corporation the use of all the public and private parks in that city in the making of that company's forthcoming feature release "Springtime," in which Florence Nash is being featured. The producers are anxious to preserve the atmosphere of the old "creole days."



THE MINNESOTA STATE EXHIBITORS WHO ATTENDED THE OCTOBER CONVENTION OF 1914

Creator of "J. Rufus" Will Write Reliance Serial

George Randolph Chester, Whose "Get-Rich-Quick" Stories Met with Instant Popularity on Their Appearance in the "Saturday Evening Post," and Later in Book Form, Agrees to Furnish the Mutual Company Fifteen Installments Entitled "Runaway June"

GEORGE RANDOLPH CHESTER, one of the best known writers in America, has been signed by the Reliance Motion Picture Company to write a fifteen instalment serial entitled "Runaway June," which will be ready for release early in January.

It is understood that the price paid Mr. Chester is in the neighborhood of \$25,000, and is said to be the highest ever paid an author to write a serial or any other story for moving pictures.

Mr. Chester's fame is world wide on account of his "Get-Rich-Quick Wallingford" series which appeared in the *Saturday Evening Post* and book form, four million copies of which have been sold to date, and Mr. Chester has already completed sixty-five "Wallingford" stories.

Although "J. Rufus Wallingford" is the best known of Mr. Chester's works, his "Cordelia Blossom" and "The Jingo" also lead toward his fame.

Chester Establishes Precedent

In writing "Runaway June" Mr. Chester has established a precedent, as he has adopted a new scheme in writing stories. Realizing that in order to produce a successful moving picture it is necessary to visualize, Mr. Chester has written his action out first, and then supplanted the word version in his story.

Mrs. Lillian Chester collaborates with her husband in all his works, and she is partly responsible for the success of "Cordelia Blossom," "The Ball of Fire" and "The Enemy," which was Mr. Chester's greatest work prior to "Runaway June."

Owing to the great popularity of George Randolph Chester, over 2,500 newspapers have been signed to run this story in serial form.

The A. P. Robyn Newspaper Syndicate of Chicago has been retained to syndicate

this story in the various newspapers, and several novel and interesting advertising plans have been developed along this line.

Mr. Chester's theme is novel and unique in many ways, and treats with a subject which is world wide and of interest to everyone, inasmuch as it deals entirely with a present-day problem of life.



GEORGE RANDOLPH CHESTER AND MRS. LILLIAN CHESTER

In talking with Mr. Chester he said: "In writing for moving pictures I find that my style must be entirely changed, and should be different from that which I employ in dramatic work and the true literary vein.

"I have analyzed the moving picture situation and realize that the majority of scripts fall short for the simple reason that the author does not visualize his story, but attempts to apply a fiction story to picture purposes.

"In writing 'Runaway June' Mrs. Chester and I have laid out the following plan. We first of all take our main plot and determine upon the lines to pursue. This has taken up considerable time, and after we have thoroughly established the thread of continuity we then take up the question of sub-plots. After that an action plot is written out entirely devoid of the dialogue. When we have this action plot so that it suits us, we then rewrite the whole thing and place our dialogue where it suitably belongs.

"The counter-plots in 'Runaway June' as I have outlined them are unique in many ways, and there is a mystery which runs through the entire story, and will not be disclosed until the fifteenth instalment.

"I have tried to adhere to the truth as much as possible, and the theme I have utilized is one that I have had in mind for years.

How He Writes His Scenario

"I realize also in writing for moving pictures that it is necessary to consider our audience, and I have adopted a theme for 'Runaway June' which is so general in scope that no matter where this picture will be shown it will meet with instant approval. I have tried to refrain from the old stunt pictures, embodying the chase element and blood and thunder, and my ambition is to produce a dramatic story of such intrinsic value that these stunts which have grown tiresome are not necessary."

Some interesting points may be brought to light in the method of Mr. Chester's way of working. One point of particular note is the fact that during their working hours Mr. and Mrs. Chester will not be interrupted and hie themselves off to parts unknown to complete each and every instalment.

Mr. Chester said that often he and Mrs.



ASSOCIATION AT MINNEAPOLIS, TAKEN DURING AN INTERMISSION IN THE CONVENTION PROCEEDINGS.

Chester have worked for eighteen hours at a stretch without even food, as they find that in order to get the best results they must be keyed up and work under pressure.

NAVAJO FILM COMPANY LAUNCHED IN LOS ANGELES

The Navajo Film Company, composed of R. H. Mouser, president; W. H. Bessell, secretary and treasurer; Jack Freise, vice-president; and Charles K. French, managing producer; a California corporation of \$100,000, with \$90,000 paid up, began producing recently at a newly constructed studio at 2450 Tevoit street, Los Angeles.

Mr. French was formerly with the New York Motion Picture Company and previous to that with other well known producers. The company will produce dramas of one and two reels each for the Kriterion programme.

Among the leading people employed by the company are William Parsons, for the past year lead with the Western Lubin Company, and Miss Lucile Younge. The scenario department will be in charge of Jack Freise, who was formerly with Pathé.

"SEATS OF THE MIGHTY" FOR CASINO THEATRE

Commencing Sunday, November 29, "The Seats of the Mighty," a photoplay based on Sir Gilbert Parker's novel of the same name, will be presented at the Casino Theatre, New York, by the World Film Corporation. Lionel Barrymore is featured in "The Seats of the Mighty." Others in this production are Millicent Evans, Glen White, Lois Meredith, Grace Leigh, Marjorie Bonner, Thomas Jefferson.

"The Seats of the Mighty" represents an investment of \$100,000 and eight months' work. This feature was made by the Colonial Motion Picture Corporation. Special music has been written for this picture by Professor Harper Garcia Smyth and Ludwig Marum.

CECIL SPOONER IN "DANCER AND THE KING"

Cecil Spooner has joined the throng of stage stars whose energy is now being turned toward the world of the screen. She has chosen as her starring vehicle her play "The Dancer and the King," which is based on many incidents in recent history. This feature is the second of the Blaney releases to be shown in the World Film Corporation program.

LAUDER VISITS UNIVERSAL CITY

During his stay in Los Angeles, where he appeared at the Majestic theatre, Harry Lauder, his wife and William Morris, his manager, were guests at the Universal's West Coast plant.

The finest issue ever published of a motion picture trade paper will appear under date of December 10. SEE PAGE 102. No orders for additional copies can be taken after December 8.

Pierce Studies Conditions in New England

Special Representative of Bosworth Encounters a Temporary Lull in Film Field But Declares That "Legitimate" Is Dead

Special to MOTION PICTURE NEWS

Boston, Nov. 25.

THE condition of the motion picture attendance in New England theatres is not up to the mark of last year, says Carl H. Pierce, special representative of Bosworth, Inc. Some exhibitors attribute this to the war; some to increased competition; some to general business conditions. There is consolation in the fact, however, that while the photoplay houses have been doing a very satisfactory business—even though it is below the records of last year—the "legitimate" houses have been doing nothing like their usual business.

In fact, the outlook for the "legitimate" houses is discouraging. Even some of the plays that did well in New York have not done well in New England. One reason for this seems to be that the "legitimate" play usually is not represented on the road by the "original" cast that made it

famous in the theatres of the metropolis.

People expect to see the famous star, but are obliged to see a "substitute." Mr. Daniel Frohman brought out strongly this advantage in the photoplay in contradistinction to the stage play at a recent banquet address, emphasizing the fact that not only does the photoplay always carry the original stars, but it shows real true-to-life scenery instead of the painted makeshift to which we have been accustomed with suffering patience.

New Englanders who are studying the situation declare that the day of the two dollar house is rapidly waning, and that the day of the photoplay feature, with its carefully directed and executed "original cast" is more rapidly coming to the front. They also expect, as business conditions improve—and they are right now picking up—that photoplay conditions will also rapidly improve.

Vitagraph Theatre Puts on Strong Bill

"The Sage Brush Gal," a Drama Reincarnating the Spirit of Western Pioneer Days, and "The Man Behind the Door," Make Hit

THE Vitagraph Theatre, New York City, offered a change of program, beginning Sunday, November 22, which included the feature pictures "The Sage Brush Gal," a drama in three parts, and "The Man Behind the Door," a four-part picturization of Archibald Clavering Gunter's entertaining story of the same name.

"The Sage Brush Gal" is a drama of the West during the early '50s, picturized from Frederick Chapin's story by Doris Schroeder and produced by Rollin S. Sturgeon, under whose direction "Captain Alvarez" and "The Little Angel of Canyon Creek" were screened. The story is told to a party of automobilists, while the chauffeur is repairing a break, by a character typical of the early California days, and is replete

with dramatic episodes characteristic of the time. "The Sage Brush Gal" is a cleverly conceived screen story, a photographic achievement whose scenes are vividly realistic, presented by a cast from the Western Vitagraph Company, including Mary Ruby, George Kunkel, William Burke, Myrtle Gonzalez, George Holt and J. A. McGuire.

"The Man Behind the Door" is a comedy and was adapted for the screen by Marguerite Bertsch who, in visualizing Mr. Gunter's novel adhered closely to the story of the book. It was produced by Wally Van, with a cast of Vitagraph comedians, including Mr. Van, Nitra Frazer, Cissy Fitz-Gerald, Albert Roccardi, Charles Wellesley, Harry Morey, William Shea and Louise Beudet.

Who Will Be the "Maid of America"?

The Young Woman Fortunate Enough to Meet All the Requirements for Big Warner's Feature Picture Will Become National Figure

WHAT young woman will tour America as the "Maid of America?"

Here are some of the requirements necessary for a candidate to qualify for the honor:

She must be American born; must be beautiful; must have had college or high school education; must have perfect figure; must dress stylishly and wear clothes well; must have a number of accomplishments that tend to further social prestige; must have personality, must have had instruction and experience in elocution; must be endowed with the dramatic instinct; must have a "screen" face.

The young woman selected will, because of the very nature of her work, become a national figure in filmdom, as she is to appear as leading woman of the organization of photo-play actors, who will interpret the

scenarios written around the various sections of the United States to be put on the screen in theatres throughout the country under the title of "America," releases to be made weekly for 40 weeks.

This monster film, which will comprise something like a hundred thousand feet when the last reel has been taken, is to be made to foster interest in the establishment of a Made in the U. S. A. Day an annual open-shop holiday, first advocated by J. Arthur Nelson, a prominent film producer and manufacturer, who is president of the United States Film Corporation.

Releases will be made through the United Film Service (Warner's Features, Inc.), which, with its 42 branches in the United States, should insure the Made in the U. S. A. Day propaganda ideal publicity.

LIVE WIRE EXHIBITORS

EDITOR'S NOTE.—It is the desire of "Motion Picture News" to include under this heading novel advertising ideas, successful schemes in the management, decoration and equipment of the theatre—everything, in fact, done by the exhibitor to stimulate his trade. We invite every exhibitor to write us about any new enterprise he has; also to come to us for advice or information along any line. Address: Editor, "Motion Picture News," 220 West Forty-second Street, New York City

PROFITING BY THE WAR

THE appearance of a "German infantryman," wearing a helmet and full regalia of the Kaiser's troops, in front of the Dreamland Theatre, 240 West Fifth street, Cincinnati, the other day, caused a furore among Cincinnati's population and at the same time demonstrated the ingenuity of Ed Bauman, manager of the photoplay house as a live-wire exhibitor.

Bauman was showing "The Last Volunteer," a war feature. He obtained the services of a young German who had formerly served in the German army. The man had saved his uniform, which he donned and stood as a sentinel in front of the big six-sheets which Bauman had stretched across his lobby to illustrate the picture.

Some citizens complained that the wearing of this German uniform was a violation of neutrality. Complaint was made to R. E. Simmonds, British consul at Cincinnati, and Chief of Police Copelan by zealous supporters of the Allies, to no avail.

The consul admitted he was powerless to prevent a man appearing on the street in any kind of costume he desired, and the police chief gave a similar dictum. The net result was that the newspapers took up the controversy and soon Bauman's house was being filled during the run of the picture.

"BUY-A-BALE" COUPON FOR SOUTHERN THEATRE

SO popular has an advertising scheme of A. S. Dickinson, manager of the new Alcazar motion picture theatre at Chattanooga, Tenn., proven that the crowds, in their eagerness to secure entrance to the theatre, narrowly missed causing a riot.

In line with other cities throughout the

country this city has been boosting the "buy-a-bale" of cotton movement, and Manager Dickinson purchased a bale, announcing that he would give away to each patron of the Alcazar a coupon, the coupon bearing a number corresponding to that on a card which would be drawn from a box in the presence of the audience entitling the bearer thereof to the bale of cotton.

These coupons were given away by him for several days. The night set aside for the drawing the crowds filled the theatre to its capacity and extended out into the street. It became necessary to close the box office, so great was the congestion. This was all that prevented the riot.

When the number drawn from the box was flashed on the screen a party in the back of the theatre, so it was stated afterward, possessed the lucky number, but was unable to make himself heard. Another number was thrown on the screen which matched that of one of the patrons further down front.

Manager Dickinson, upon learning that the party having the number corresponding to the first one exhibited, was present at the drawing, succeeded in settling the matter satisfactorily between the two lucky patrons.

The Alcazar, although in operation only a short time, is proving popular. Only high-class features are shown there.

PHOTO COUPONS A SUCCESSFUL STUNT

PHOTO coupons are coming into rather extensive use as business boosters among exhibitors in New Haven. They were first given out at the Orpheum theatre, in Savin Rock, being distributed in such large numbers that there are now a great many devotees of the "silent drama" who have private collections of photographs of film stars.

At the Orpheum, one coupon is given with each admission. Ten may be exchanged for one photograph of any popular motion picture actor or actress. Any number of subjects are offered.

PROFITS ON SECOND RUNS

MANAGERS of several of the retail district larger theatres of Los Angeles who have experimented with running pictures that had been shown earlier in the season to good business, found this to be a successful way of eliminating expense and not materially affecting the box office receipts.

Return engagements proved that the feature pictures were as good drawing cards as when first shown.



THE PREMIER, BUFFALO, N. Y.

"THE SCREEN FOR ADVERTISING"

AN example of what can be done in the way of a high-class exhibition in a comparatively small house is furnished by the policy of the Lyric theatre in Greensburg, Pa. This house has a capacity of 288 and uses Paramount World Film Corporation productions and the Mutual schedule.

In telling of the scheme the manager, M. Manos, said he is making money and uses an orchestra in addition to an orchestration. He advertises freely throughout the town and has the people interested and never hesitates to laud his wares on his screen, telling of the pictures to come.

He goes to Pittsburgh and makes his bookings and then returns home and gets his slides ready. Sometimes he is advertising his plays for three weeks in advance of the time they are to run. He is a firm believer in the saying that "It Pays to Advertise," and he is doing plenty of it right in his theatre, where the cost is cut down to practically nothing.

TO GET HIGHER PRICES, ADVERTISE

STUBBS AND PADDUCK, owners of the Savoy theatre at San Bernardino, Cal., tried an increase of prices from ten cents for adults and five for children to twenty for adults and ten for children, three nights last week while showing "The Spoilers," and played to capacity houses.

The Savoy has 800 seats. The three-night engagement was advertised in the local papers, on billboards and a big truck gaily decorated with flags and lithographs visited the whole city.



THE NEW ELLEN TERRY THEATRE, BUFFALO, N. Y.

Industry Is Reaching Solid Basis, Says Wright

He Sees Strong Tendency to Book Pictures Through National Sales Organization, and Declares That This Concentration in the Marketing of Releases Means Benefit to Exhibitors, Who, on the Whole, Are Aligning Themselves with Such a Movement

WILLIAM H. WRIGHT, of the Excelsior Feature Film Company, whose wide business experience gives his views a significant interest, was recently interviewed. Mr. Wright's observations on certain conditions of the motion picture industry follow:

"A man I know has pasted over his desk a printed motto which says: 'There is no fun like work,' and this surely is an excellent motto for the average business man. I find in the motion picture industry, however, a tendency to rearrange this into: 'There is no work like fun,' and while it is true that the object of the motion picture industry is to furnish amusement, I am convinced from my own observations that the industry as a whole would be far better served if the men composing it took their business more seriously than they do at the present time.

"It is a curious thing that in an industry, which has been as profitable as motion pictures, that some of the people in it should be as apparently irresponsible as they are.

"I am inclined to believe that perhaps some of this is due to the comparative newness of the business itself. Any new business developing as rapidly as the motion picture industry has attracts many men, who, for one reason or another, find it advisable to seek a new field for their activities.

"The solution is a comparatively simple one. The strength, financial responsibility and commercial integrity of any industry is exactly proportionate to the individual honesty of the men composing that industry. If, therefore, each manufacturer, exchange man and exhibitor will feel that the honor and integrity of the entire industry

rest in his hands, and will govern his acts accordingly, living up to the highest commercial standards, and observing not only the letter but the spirit of the law, and feeling that his promise or his word, once



WILLIAM H. WRIGHT

given, or a contract entered into, is an absolute bond for the specific performance of which he personally assumes the responsibility, each individual unit will feel its responsibility to the utmost, and the industry as a whole must unquestionably benefit.

"In the present movement concentrating the booking of pictures in the hand of

strong national sales organization, such as the Alliance Films Corporation, through which all Excelsior pictures are released, I can only see a benefit both to the manufacturer and the exhibitor. The men at the head of institutions such as this are men who have proven their ability in commercial life, and stand today as the representative men of the film industry, not only because they are financially solid, but because they are men of moral integrity, men who would not descend to the petty tricks that are unfortunately the characteristics of some of the smaller, I mean mentally smaller, business men in the industry.

"I can see the more substantial and the more solid manufacturers, those who produce the most artistic and meritorious pictures, affiliating themselves with these larger booking organizations, not only because these organizations are more responsible financially, and assure a wide distribution, but because business relations existing between the manufacturer and the booker must be based on much mutual confidence. Confidence can only result from a reputation of previous satisfaction in dealings.

"I can see the better class of exhibitors aligning themselves with these sales organizations, because of the high grade of pictures offered, and they, too must appreciate the satisfaction in dealing with the booker of established reputation, financial worth and personal integrity.

"The days of the shoe string operator, the wild cat booker and others of that tribe are surely numbered, if not already past. The motion picture industry has lived through much abuse, both from the inside and the outside, and today stands an enormous industry, solidly founded on a public demand, representing millions of invested capital and untold thousands of employees."

\$75,000 Studios Planned by Dyreda Corporation

Will Be Located near New York City—Firm Will Release Through World Film Corporation—Will Double Number of Releases

PLANS have been submitted for the erection of a studio and complete motion-picture plant for the Dyreda Art Film Corporation, who has been using the Old Reliance Studios at Yonkers, N. Y., and who have already made two features which will be released through the World Film Corporation, of New York City. This plant will cover several acres and will be equipped with all the modern devices—Cooper Hewitt lights, revolving stages, etc. The exact location of the new studio has not been given out as yet, but it is understood that it will be conveniently located to New York City. The company have decided to spend at least \$75,000 on their new home.

The interior stage will be 70 x 100, and will accommodate several sets at one time. It is the intention of the company to double the number of its releases through the World Film Corporation, and this, of course, will necessitate a large force of actors at all times.

The personnel of the Dyreda company includes Frank L. Dyer, president; J. Parker Read, Jr., vice-president and general manager; J. Searle Dawley, director of productions, and J. H. Redfield, treasurer. Mr. Dyer will be remembered as the former president of the General Film Company and as president of the Thomas A. Edison Company, at East Orange, N. J., for several years. Mr. Read achieved a world-wide reputation as producer of the motion picture "A Trip to the Garden of Allah" and of the picture "Victory."

J. Searle Dawley has been spoken of as the man who made the Famous Players famous, as he produced the first fourteen pictures they turned out.

EDISON REVIVES OLD FAVORITE

Upon the request of many exhibitors the Edison company is reviving in two parts that well-known film of a few years ago, "Where Is My Wandering Boy Tonight?" Marc MacDermott will appear in the role.

ELEANOR WOODRUFF SAILS FOR FRANCE

Eleanor Woodruff, whose plan to depart from France to enter the Red Cross service was announced in these columns last week, has engaged passage on the Fabre liner *Madonna*, sailing on December 7. Miss Woodruff will land at Marseilles, and from there go to Paris, where she will be assigned to the hospital of which she is to have charge. Since the announcement of her contemplated departure for the scene of the war, Miss Woodruff has been in receipt of a great many messages from her friends and admirers wishing her a safe trip and a speedy return.

The finest issue ever published of a motion picture trade paper will appear under date of December 10. SEE PAGE 102. No orders for additional copies can be taken after December 8.

In and Out of Los Angeles Studios

Special to MOTION PICTURE NEWS

Los Angeles, Nov. 23.

FILM players have been given "weather vacations," owing to the cloudy mornings which have prevented work until almost midday, and even with the presence of Carl Laemmle, Samuel Long, S. S. Hutchinson and other notables of the film industry, the production has fallen short of the usual.

The weather conditions have made it possible for officers and players of the Universal, Kalem and American companies, respectfully, to get acquainted, and this will no doubt bring results.

The Charles Giblyn Nestor company has made a one reel drama, "The Dear Old Hypocrite," by Ruth Ann Baldwin, in which Murdock MacQuarrie masquerades as a poor old man who is deaf, without other relatives than a niece—daughter of an estranged brother. He does this to test their fidelity to him, and finding them willing to sacrifice their comfort and happiness in the time of misfortune favors them not only with ready money but in his will. MacQuarrie is supported in this by Agnes Vernon and W. K. Wilson.

The unusual business caused by the parcel post department in an exaggerated form is used as the plot for "The Village Postmaster," a one reel comedy made by the Jack Blystone Joker comedy. Ernest Shields plays the name part with a cast composed of Betty Schade, Phil Durham and Eddie Boland. The scenario is by Phil Walsh.

In returning to the U studio from a location the Frank Lloyd Rex company passed a gypsy camp equipped with unusually fine wagons and tents, and all players, including the director, decided the use of the people and their property would make elegant settings for a romantic story. A request was made for a scenario in which a gypsy camp was needed. The task of writing one was assigned Ruth Ann Baldwin, and until two o'clock in the morning she remained at her typewriter. Being handed the complete script in the morning Director Lloyd announced work on the multiple reel picture, "The Gambler," being produced by the company would be deferred until the gypsy picture was made.

"Captain of Villainy" Delayed

After a change of make-up and costumes to suit the new parts the three auto loads started for the camp of the nomads. But in the night, at the order from the police department, the campers had folded their tents and departed for parts unknown. For hours the autos chased them but with no success. The company now has an excellent scenario for sale, and is back at work on "The Gambler."

The Jack - Kerrigan - Jacques Jaccard

"Terrance O'Rourke" company, delayed in the production of the fourth of the series, "The Captain of Villainy," by the foggy and cloudy weather, are still sojourning in Morocco at Universal City.

Pauline Bush is featured in a semi-western one-reel picture from a scenario by Tom Forman, of the U department: "The Desert Breed," under the direction of Joseph De Grasse, and many of the exterior scenes will be made on the American Sahara desert.



BEATRIZ MICHELENA

"Guv'nor" Otis Turner is now in the midst of filming the second of his "Sanford Quest, Criminologist" series, which will be released under the title of "The Mystery of the Romanoff Ruby." Mr. Turner's regular players, Herbert Rawlinson, William Worthington, Anna Little and Helen Wright play the principal parts.

"Wanted, a Chaperone," is the name of a two reel Nestor comedy photographed under the direction of Al E. Christie, and in which appears all his company—Victoria Ford Lee Moran and Eddie Lyons. Lee Moran has caused retakes of several scenes because of his laugh producing interpretation of the part of an eccentric woman of some forty-odd years.

The finest issue ever published of a motion picture trade paper will appear under date of December 19. SEE PAGE 102. No orders for additional copies can be taken after December 8.

Calder Johnstone with the Bob Leonard company making exterior scenes for "The Master Key" series writes the U scenario department from San Francisco that the company is meeting with unusual success in the work, and results have been far better than anticipations of either Mr. Leonard or himself.

Ford Sterling, Robert Harron, Dorothy Gish, Robert Leonard, Ella Hall, Kathlyn Williams, Roscoe Arbuckle and Charles Chaplin will go to San Francisco, and attend the first annual ball of the Screen Club of that city on the evening of November 28.

Charles Stillwell, vice-president of the club, spent a week here, and in addition to making arrangements for players to attend the ball found the local producers ready to aid the new organization with liberal orders for advertising in the program for the event.

Albuquerque Companies

Both the farce and comedy drama companies of the Albuquerque Film company resumed production last week, the former in charge of Archer McMacken, and the latter under the direction of Gilbert P. Hamilton, and with Dot Farley playing the leads.

Mr. Hamilton is to produce another series of "The Frontier Twins" pictures, originated by Miss Farley some months ago, and while Miss Farley prepared scenarios for this series Mr. Hamilton has been trying to find someone to play the other twin. Miss Farley has completed her work, and now the director has confessed of failure on his part. It is necessary for this reason that the series be delayed.

The Komic company at the Reliance-Majestic studio has made the thirteenth of the "Bill" series and just to show that the members were not superstitious they began work on the production Friday the thirteenth and in order to carry out the scheme several scenes were added to the scenario in order that the picture contain fifty-two—fourth times thirteen.

Ethel, the stenographer in this subject, succeeds in persuading her boss to be the guest of honor at the "S. M. B."—stenographers' masque ball—and Bill, the office boy, mixes up the costumes to be worn by the boss and Ethel's sweetheart, causing numerous cases of mistaken identity which form many ludicrous situations. Fay, Tam, Eddie and Tod play the leads. And Fay wore her fortissimo gown.

The two reel Reliance picture, "The Best of the Year," an adaptation from a story of the same title by Robert Livingston Beecher appearing in *Pearsons' Magazine*, has been completed by a company playing under the direction of Jack Adolf. This picture deals with a baffling murder.

A headless body of a man is found, and the only clue to his identity is a button of a peculiar color on his coat. A cub reporter takes the only cue, and in a Sherlock Holmes, analytical deduction method clears up the mystery. The members of the company include Eugene Pallette, Sam de Grasse and Francelia Billington, and at all times had the co-operation of a local newspaper reporter who served in an advisory capacity.

Love Affair of a Soldier

The Donald Crisp Reliance-Majestic company is producing "At Dawn," from a scenario by Ferdinand Moore, a well known short story writer. The settings are in America and the Philippines, and show the two love affairs of a young soldier. When he left his sweetheart in America he swore he would be true.

A native belle of the Islands attracts him. Then when his American sweetheart inherits a fortune and goes to see him, he tries to break with the Philippine girl. She persists and he finally commits murder. The parts are played by George Seigman, Billie West, Wallace Reid and W. E. Lowery.

Fred Kelsey, R. and M. director, who has the reputation of just accidentally doing



DANIEL GILFEATHER (Balboa)

things that bear him into print, is at it again. He is producing another newspaper story to be released under the name of "The Exposure."

In this Irene Hunt is appearing as the "sob" sister, and in ferreting out a graft story reveals the fact that her fiance is the leader of the crooked politicians. The picture, Kelsey says, will have the smell of printers' ink, and run through the projecting machine just like paper off the roll goes through the press.

Charles Fais, Los Angeles business manager for David Horsley, is the busiest man of the film colony, daily making arrangements for production for the Centaur company on the west coast. Mr. Fais states he has not said a word, but report has it that seven companies will be put to work in the very near future. This rumor has not been denied or confirmed by Mr. Fais, who states he will be in a position to give out definite details within a few days.

Bracken Back at Work

Pertram Bracken, who for two months has been taking a vacation, has resumed

work at the Balboa Amusement Producing company studio at Long Beach, and will in the future act as director general of the producing companies, six of which are being organized at this time. The company has made a long time contract with Mr. Bracken, and it is current in photoplayers' circles that he will receive one of the highest salaries paid on the west coast.



MABEL VAN BUREN (Lasky)

Mr. Bracken, who filmed the six reel production of "St. Elmo" and a score of other features for this company, was the director for Gaston Melies during his worldwide tour, and is in every way a very capable director.

Besides directing his own group of players in the larger features, Mr. Bracken will personally supervise the five other companies engaged in filming pictures required by the contract recently made with the owners of the Balboa company, H. M. and E. D. Horkheimer, by one of the largest film marketing corporations. Under the terms of this contract the Balboa company must produce a minimum of six full reels each week.

The first feature to be made by Mr. Bracken will be an adaptation of Mrs. Augusta Evans' novel, "Beulah," in six reels, which is a sequel to Mrs. Evans' story, "St. Elmo," the film version of which was produced by Mr. Bracken. Some of this producer's current releases are: "The Square Triangle," "The Test of Manhood," "Heart of the Brute," "The Vow" and "The Winner."

The Universal company under the direction of Francis Forde has taken up the production of a six reel feature, "The Campbells Are Coming," which will be of a historical nature relative to the Sepoy rebellion in India. In the preparation of the scenario special attention was given to the correctness of the historical facts, and about this was woven a pretty romance.

Practically all of the sets used in this picture will be large ones. The gates of the city of Delhi are of such size as to permit sixteen soldiers marching abreast

to pass through. The wall about the city is forty-four feet in height and four hundred feet long. Forde will play the part of Nana Sahib, and Grace Cunard will be seen as a Scotch girl. The cast includes Harry Schumm, Duke Warren, Lou Short, A. Denecke, Mary Granville and hundreds of others. Several companies of National Guards are expected to take part, and there will be more than a thousand "extras" in the battle scenes. It is expected one month's time will be required in the filming of this picture.

Leslie Carter Play Under Way

The Tiffany Film Company has perfected its producing organization, and for ten days has been at work on the filming of "The Heart of Maryland," featuring Mrs. Leslie Carter, at a studio on Santa Monica Boulevard. For the battle scenes in this picture a tract of 12,000 acres of land east of Los Angeles has been leased, and a village consisting of replicas of the homes of southern aristocrats, together with a large church, is being built.

This village will be destroyed by dynamite and other explosives. The cast selected by Director Herbert Brennon includes J. Farrell MacDonald, Bert Hadley, Clarence Burton, Raymond Russell and Vivian Reed, besides William E. Shay, who plays the male lead. The company expects to complete the picture by the second week in December.

Max Figman, now in charge of the pro-



HENRY KING (Balboa)

duction of the Masterpiece Film Company in filming "The Truth Wagon," is applying the same rule he used in productions on the legitimate stage—every player be an actor with an education sufficient that he perfectly understands the part he is playing, and be able to interpret it. No marionettes for Mr. Figman.

"The Quest of the Kingdom of Childhood" is a five reel photoplay filmed under the direction of William A. Gibson, of Los Angeles, for showing at the San Diego exposition during the year of 1915. Mr. Gibson has spent five months in the filming of this feature, which is of a fairy-

tale nature, embodying the scenic wonders of southern California. It could well be classed an educational picture. More than ten thousand school children took part in this, and all but three of the members of the cast are children.

"Hi Judd, Old Sunshine," is the name given to the four reel picture featuring Macklyn Arbuckle in the main part, filmed under the direction of Lois Weber at the Bosworth studio. The story for this was written by Mr. Arbuckle himself, and the scenario prepared by Miss Weber. It is of the same type as "The County Chairman" and other legitimate stage successes of this well known actor.

Phillips Smalley is having unusual success in filming the story written by Elsie Janis for her first motion picture appearance. The positive prints of the first two four-hundred-foot spools taken bring out the fact that Miss Janis photographs exceptionally well. The actress is delighted with her work before the camera, and is now writing the story for her second picture.

Another Zoo Picture

Director E. A. Martin has been making another one reel Selig animal picture, "Love and the Leopard," with settings in South Africa—that is the extreme west portion of the Selig Jungle Zoo farm. The leads for this are Billy Stole and Catherine Henry, supported by Joe Hazelton, Lillian Hayward, Edward Wallock and C. C. Holland.

W. C. Clifton, of the Selig scenario department, has written a pretty romance about an eccentric society girl, played by Bessie Eyton, who tires of the idlers and longs for a lover of the primitive type. The son of a railroad president, Tom Santschi, learns of this and pulls off the real Lochinvar stunt. The title for this is "The Primitive Way," and among those of the cast are Helen Castle and Barney Fuery.

It is very probable that the Los Angeles film colony will be represented in the parade of warships through the Panama Canal next March when President Wilson comes to the west coast, as Captain Wilbert Melville, director general of the Lubin Western company, has been advised by ship builders in New York that his recently purchased yacht, which was left on the east coast for the installation of oil burners, will be ready for the cruise the latter part of February. The new yacht, the *Anoma*, carrier a crew of twenty-eight men, is 230 feet in length over all, and has a twenty-two foot beam. This boat was purchased by Captain Melville while on his recent trip in the east, and is to be used exclusively for Lubin features and the pleasure of its owner.

The Lubin players have been filming a two reel subject, "The Song from the Heart," of the same nature as the "Music Master." The lead character part is taken by Melvin Mayo, and the picture features Bertie Priest, a vaudeville dancer, who completed a tour over big time circuit with her appearance here recently. One scene of this picture, that of the interior of a theatre in grand opera season required one hundred and eighty extra people.

Alco Receivership Lasts Just One Day

President Walter Hoff Seely Buys Out Al Lichtman and William Sievers, and Equity Proceedings Are Discontinued—John D. Dunlop Enters Directorate

THE suit in equity which was started by William Sievers, of St. Louis, as treasurer of the Alco Film Corporation, and which resulted in the appointment of a receiver, was discontinued November 21. Stock held in the Alco Film Corporation by Al Lichtman and William Sievers was purchased by President Walter Hoff Seely and his associates. Contracts were signed by which the stock is to be transferred, and the papers were also drawn for the discontinuance of the proceeding.

The receivership lasted for but a single day.

Mr. Seely and his associates, who purchased Mr. Lichtman's stock and that of Mr. Sievers and his associates, have brought new capital into the business. The Alco releases will go forward as scheduled, and many other leading legitimate successes and stars have been signed for features yet to be announced.

At the formal signing of the contract President Seely and his associates were represented by Hon. Job E. Hedges, and Mr. Lichtman and Mr. Sievers by Ex-Congressman William S. Bennet.

Alco exchanges throughout the country have telegraphed to President Seely expressions of their entire confidence in him, his associates and in Alco. They are going ahead vigorously distributing the Alco releases throughout their territory, as well as the radium gold fibre screen and other theatre supplies which are handled by the Atsco department of the releasing corporation.

Releases Will Be Followed

The list of releases which has already been announced will be followed by the reorganized corporation. Florence Nash, Mabel Taliaferro, Madame Olga Petrova, Jane Cowl and Beatriz Michelena will appear as has been stated in photoplays based upon the legitimate successes already announced.

The new impetus which has been given to the releasing corporation is being felt by the producing companies allied with Alco. These are going ahead working vigorously upon their respective photoplay productions. The Alco group of producers, which is composed of the All Star Feature Corporation, the California Motion Picture Corporation, Popular Plays and Players, Inc., B. A. Rolfe Photo Plays, Inc., and the Life-Photo Film Corporation, has expressed its entire confidence in the reorganized releasing corporation.

The reorganization is going forward with the idea of facilitating, if possible, distribution of the Alco program. It is also desired to improve, if possible, every condition under which the parent company and the allied companies work.

Kane Remains as Exchange Head

Robert T. Kane continues as supervisor of exchanges. He will visit, as heretofore, the branches throughout the country and bring them into better relations with one another and the parent company. He acts as a medium through which ideas are passed both between various exchanges,

and between exchanges and the home company.

Harry Cohen becomes the new manager in place of Al Lichtman. Mr. Cohen was for years the feature manager for the General Film Company and established for the General many successful branches over the country.

While he remains with Popular Plays and Players, Inc., many of his duties there will be taken over by one of his assistants who is promoted for the purpose.

J. D. Dunlop Joins Alco

With the opening of court Monday Judge Learned Hand dismissed the suit in equity brought by William Sievers, of St. Louis.

John D. Dunlop, prominent financier and banker, well known in the downtown financial sections of New York, has entered the directorate of the Alco Film Corporation, which action probably gives this enterprise the most substantial financial backing of any firm of similar activity in the field.

Mr. Dunlop, when seen at the office of the Alco Film Corporation, expressed himself as highly gratified at the condition of the corporation, and said he was entering the film field only after having subjected the company to the most rigid scrutiny.

"NEPTUNE'S DAUGHTER" HAS CAPTURED CANADA

"Neptune's Daughter," the big Universal feature, captured Canada. Opening at the Princess, Toronto, for one week the business was so satisfactory that the second week was immediately booked, and continued to play to increased receipts.

In Montreal the same film was presented at His Majesty's Theatre, and business was so good that the second week was booked.

In Ottawa, at the Russel Theatre, the governor-general and members of Parliament, which is now in session, attended the opening performance. The business is excellent. L. N. Scott, manager of the theatres in St. Paul and Minneapolis, who booked "Neptune's Daughter" originally for a week, booked it again for presentation within the month.

VITAGRAPHIANS OFF TO NEWPORT

Theodore Marston, the Vitagraph director, with Dorothy Kelly and James Lorrison, are at Newport, Rhode Island, to portray scenes off the coast. They will employ the guards of the life saving station at that point to rescue Miss Kelly from a sinking vessel. The breeches-buoys will be used and a thrilling scene will be enacted in the surging sea.

The finest issue ever published of a motion picture trade paper will appear under date of December 19. SEE PAGE 102. No orders for additional copies can be taken after December 8.

Admission Prices Rising, Kane of Alco Finds

Demand for Features the Cause—On Account of Superior Quality of Pictures People Meet Advance Without Complaint

ROBERT T. KANE, supervisor of exchanges for the Alco Film Corporation, has just returned to the city after a trip in the interests of his company through Pennsylvania, Michigan, Chicago and Minnesota. He will leave again within a few days to visit the Alco exchanges in other parts of the country. Mr. Kane's mission is to carry the Alco gospel to exhibitors and exchange men. He keeps the various exchanges in constant co-operation with one another and with the parent company in New York.

Mr. Kane got a general idea of film conditions in the sections of the country which he visited.

"I believe," said he, "that the feature has flashed the doom of all short-reels except purely as fillers in. This foreshadows, I think, a general increase in admission prices. Managers who have been getting five and ten cents are now forced by the demand of the public for features to charge from fifteen to twenty-five cents. The average show, I find, which is popular in the great country outside of New York runs an hour and a half. In the larger houses there is an organ and an orchestra. The highest price of admission in any of the cities which I visited is fifty cents.

"In the smaller towns I find that there is a growing tendency for the 'Opera houses' to fill in with feature pictures. Otherwise these Opera Houses would be dark three or four nights a week. There are very few legitimate shows on the road today which visit these smaller houses, so the people are turning in increasing numbers to moving picture features for amusement. Where the projection is good the management of the Opera Houses are easily able to get twenty-five cents admission.

"A new development in motion picture theatres is surprising to the patron and lover of the legitimate. Big feature



ELSIE JANIS—HER FIRST PORTRAIT SINCE HER ARRIVAL ON THE WEST COAST

photoplays are now being put on in the large cities for 'runs.' Just at present these 'runs' are only for three weeks, but undoubtedly the time will be increased. Beatriz Michelena in 'Salomy Jane,' for instance, is at present having a run of three weeks at the Ziegfeld theatre in Chicago. It was preceded by Ethel Barrymore in 'The Nightingale.' 'The Nightingale' ran two weeks and broke all Michigan avenue records.

"Those of our exchanges which I visited reported a constant demand for return dates in the cases of 'The Nightingale' and 'Salomy Jane.' It is a result of this demand that Augustus Thomas is preparing to put Miss Barrymore in two more plays which he is writing for her. And the California Motion Picture Corporation in response to the same demand will follow 'Salomy Jane' with other plays of the real West.

"There is a big demand over the country for Western plays. But they must not be such as many producers have offered in the past. People want no idea of Western life conceived on Broadway. It must be the West as it is today, or the West as it was in the past generation."

VITAGRAPHIANS SEE LACKAYE ACT

Sixty Vitagraph players and members of the executive staff of the Vitagraph Company recently attended a performance of "The High Cost of Loving," Lew Field's presentation, at the Republic Theatre, New York City. Their attendance was complimentary to James Lackaye, their friend and former associate, who was well and popularly known in Vitagraph pictures.

"CIRCUS MAN" RELEASED BY LASKY

"The Circus Man," from George Barr McCutcheon's novel, "The Rose in the Ring," with Theodore Roberts in the name part, was released by the Jesse L. Lasky Feature Play Company, November 19.

Florence Dagmar, a new discovery of Cecil DeMille's, plays opposite Mr. Roberts.

S. H. TWIST CONVALESCING

Stanley H. Twist, recently connected with the Universal Film Manufacturing Company, who has been ill at the Flower Hospital suffering from a nervous breakdown, is convalescent. He left a few days ago for Los Angeles, to go to his mother's home, where he will rest before resuming his activities with the Universal.

The finest issue ever published of a motion picture trade paper will appear under date of December 19. SEE PAGE 102. No orders for additional copies can be taken after December 8.

GERTRUDE McCOY IN EDISON CHRISTMAS FILM

"The Birth of Our Saviour," the Edison Christmas drama, depicting the Nativity in the Stable and the Adoration of the



GERTRUDE McCOY

Magi, affords an excellent opportunity for Gertrude McCoy to display her talents with exceptional ability in the role of the Madonna.

INCEVILLE DIRECTOR BACK AT STUDIO

George Osbourne, the Inceville director, is about to pack up and return to his duties at the studio of the New York Motion Picture Corporation in Santa Monica, Cal., after a vacation of two weeks spent in the northern part of California.

According to letters that have been received from Mr. Osbourne he has been whiling away the time in motoring and water sports. The director was unusually busy during the few weeks prior to his departure for the north. His productions included "Nipped," "The Vigil" and "The Game of Life."

BRONX MOVIES CIRCLE GIVES BALL

The entertainment committee of the Bronx Movies Circle, which set November 22 as the date for the third annual ball of the organization at the Burland Casino, Westchester and Prospect avenues, the Bronx, N. Y., did everything in its power to make the affair the sensation of the year in that part of the city.

They worked day and night to get to popular celebrities, including Clara Kimball Young, and King Baggot to attend and also Maurice Costello, Robert Warwick, Steward Holmes, Darwin Carr, Ned Finley, Lillian Walker, Norma Talmadge, Mary Anderson, Leah Baird and many others.

NEW AMERICAN COMPANY FORMED

Harry Pollard, American Beauty brand director, was in Los Angeles recently and selected a company of players who accompanied him back to Santa Barbara, where they took part in the production of three, four and five-reel pictures. Mr. Pollard and Margarita Fischer play the leads for the new company, and Mr. Pollard has charge of the direction.

Looking Ahead With The Producers

Blanche Sweet Is Engaged by Lasky

SAMUEL GOLDFISH announces a contract has been concluded between the Jesse L. Lasky Feature Play Company and Blanche Sweet, whereby she will appear in the new series of Lasky-Belasco productions now being staged for the screen. Miss Sweet was selected by Mr. Belasco and Cecil B. De Mille, for the Lasky-Belasco productions, and signed a contract for a term of years at a record breaking salary.

Blanche Sweet needs no introduction to lovers of photoplays, for, though she is only eighteen years of age, she has been making history in this art for several seasons. She is especially famous for her intense though restrained gestures and a marvelous command of facial expression for "close up" effects.

Up to the present time Blanche Sweet has been mainly associated with David Griffith, in most of whose leading productions she has appeared. She worked under Mr. Griffith while he was directing for the Biograph Company, and played the title role of "Judith of Bethulia," which electrified all America last spring. More recently she has been working with Griffith for the Reliance and Majestic companies, and has played the leading feminine roles in "Home, Sweet Home," "The Avenging Conscience," "The Escape" and other film plays which have reached Broadway.

Under the management of Mr. Lasky, and appearing in Belasco productions, Miss Sweet will be creating roles for dramas already of international fame, and she will be a member of the family of stars, which includes Dustain Farnum, Robert Edeson, Marguerite Clark, Edith Taliaferro, Edmund Breese, Charles Richman, Edna Goodrich, Theodore Roberts, H. B. Warner and others.

Miss Sweet will make her first appearance as a Lasky-Belasco star in William C. De Mille's famous success, "The Woman," which played at the Republic

Theatre for two seasons, and which will be ready for release on February 15. Work will begin within a week.



BLANCHE SWEET

Blanche Sweet has the distinction of being the first film star to join the Lasky ranks, hitherto made up of stage celebrities.

CATHRINE COUNTISS FOR NEW LIFE PHOTO PRODUCTION

Cathrine Countiss, who was starred in "The Awakening of Helena Ritchie," "The White Sister," and "The Christian," has just been placed under contract by the Life-Photo Film Corporation for photoplay work. Miss Countiss will do her first work for this producing organization in the photoplay field by assuming the lead in "The Avalanche," another recent acquisi-

tion of the Life Photo Film Corporation. Present plans provide for the release of "The Avalanche" through Alco as the next Life-Photo production following "Springtime."

This former Broadway success deals with the attempts of a woman to wreck a man through manipulation of the mining stock Avalanche. Before the man's marriage, he and the woman were engaged. She subsequently married. Her husband died. Meanwhile her former fiance has married. This arouses the hatred of the central feminine figure in the play, which Miss Countiss is to portray.

SCENES TAKEN ON NOTED COLORADO RANCH

"When East Meets West," a forthcoming release by the Thanhouser Film Corporation, was taken on the Walsh ranch, near Denver, the birth place of the famous \$1,000,000 McLean baby. The picture, which has Mignon Anderson and Morris Foster in the leads, furnishes an excellent illustration of life on a well-ordered ranch.

The wild riding and milling herds are the same as in the old days, but great substantial barns and buildings have displaced the "dobe" shacks and fence corrals. This picture is one of the much-heralded releases made by the Thanhouser "Yellowstone" company.

GISH SISTERS TO STAR IN MUTUAL DRAMA

For the first time in more than a year the Gish sisters, Lillian and Dorothy, are featured together. They appear as co-stars in the Majestic-Mutual feature "The Sisters," written especially for them and produced by W. Christy Cabanne.

In working together in "The Sisters" Lillian and Dorothy have succeeded in adding their natural personal touch in their relation to each other as sisters, which makes this charming pastoral feature an excellent offering.

SCREEN FAVORITES WHO WILL FIGURE IN KINETOPHOTE'S NEW FEATURE "THE SPAN OF LIFE"



GLADYS WYNNE

EDWARD MACKAY

LYSTER CHAMBERS

LIONEL BARRYMORE

ALMA MARTIN

"SPAN OF LIFE" FULL OF REALISM

The Kinetophote is expecting big results from the first feature to be released by that corporation with Lionel Barrymore as the star. The picture is "The Span of Life," which has been picturized by Catherine Carr from the late Sutton Vane's famous melodrama of the same name.

Mr. Barrymore has associated with him in the picture such well known players as Gladys Wynne, Alma Martin and Lyster Chambers. Two well known child actors also play in the piece, Ogden Childs and little Barry Phillips. The picture is directed by Edward Mackay, who has appeared with success in several of the Kinetophote features.

"The Span of Life" was not taken without some very trying work on the part of the company. Mr. Chambers came near being thrown from the top of a cliff by his horse. An automobile which was carrying the company down the side of Baldy Mountain went wrong, and the women of the party had to jump for their lives. And in the taking of the great "span" scene Miss Wynne came near falling from the human bridge made by the three acrobats who stretched themselves across a deep chasm. The story is more thrilling than the stage version because of the realism which has been injected into the screen version.

With Barrymore in the picture much is expected from it. It is to be released on December 7.

SPokane COMPANY IS INCORPORATED FOR \$10,000

Special to MOTION PICTURE NEWS

Spokane, Nov. 24.

Local photographers have announced the organization of the Photo-Action Company of Spokane, with an authorized capitalization of \$10,000. The company is in possession of a studio and equipped to do motion picture commercial and feature work.

Charles A. Libby is president and treasurer of the company and Raymond Kahn is vice president and secretary. Others in the enterprise are George Felt, William Moore and Howard Fisher.

"Springtime" Replaces "Tigress" on Alco Schedule

ARRANGEMENT of the Alco release dates permits the public to see Florence Nash in her screen debut, "Springtime," earlier than had been intended. It is a Life-Photo production, released on December 7. Olga Petrova in "The Tigress," which had been scheduled for that date, goes over to December 21.

The readjustment was made necessary because of the large effects which the producers of "The Tigress" are using. The motion picture public benefits from the change, since it permits them to see "Springtime" at an earlier date, and also gives the producers of "The Tigress" ample opportunity for big screen values.

Edward M. Roskam and Miss Nash, with a company of thirty, have almost completed the work of filming the Booth Tarkington photoplay, "Springtime," in New Orleans, in which locale the author placed the story.

Miss Nash has been long and favorably known to the public of the legitimate theatres. Although one of our youngest actresses, she has played important parts. These have been, however, characters with accentuated traits. In "Springtime" she is seen in an ingenue role, pure and simple.

Florence Nash was born in Troy, educated in a Canadian convent and in Albany. Her father was Philip F. Nash, a well-known theatrical man. So it seems only natural that Miss Nash should turn to the stage. She has been equally successful in singing and dramatic companies and in vaudeville. She began her stage career with a short season in stock.

Then came the first of her character creations. She made an instant hit as the lisping girl in "The Boys of Company B."

Later she was with "The Algerian." Following this she joined De Wolf Hopper, and an engagement in "When Sweet Sixteen" followed. Shortly after this she was promoted to the honors of leading woman to Thomas W. Ross, supporting him effectively in "An Everyday Man."

The vaudeville claimed Miss Nash's attention next. She was popular over a wide stretch of country in the sketch "In 1999." Next Miss Nash returned to the legitimate. In "Within the Law" there was an oppor-

tunity which the management felt was eminently suited to her talents. The role of Aggie Lynch, a type of the "tough girl," was entrusted to her.

Mr. Roskam and a company of thirty are still in New Orleans. They report that the weather has been perfect and the picture is nearly complete. They were granted permission by the municipal authorities in New Orleans to make many of the scenes in municipal parks which the action of the story required.

Other scenes were photographed in the localities described by Mr. Tarkington. Some of the scenes of the original "Springtime" were laid in the creole quarter, others in historic mansions. Mr. Roskam and his associates sought out these buildings.

NEW COSMOS RELEASE WILL BE READY SOON

The photoplay which the Cosmos Feature Film Corporation has chosen to succeed "Hearts and Flowers" is entitled "The Little Girl That He Forgot." Beulah Poynter plays the title role with her usual success.

"The Little Girl That He Forgot" was written by Miss Poynter and as a play proved a wonderful success. The story takes place in a lumber camp in Missouri and the characters are the plain but sturdy folk found in that section of the United States.

A commanding love story, in which the little swamp girl meets and learns to love a wealthy engineer from St. Louis, holds the interest throughout. The love breeds a familiarity that causes the girl of the swamps much trouble and sadness and even brings her to prison and a threatened hanging when her lover brings a reprieve and his old-time love to her.

In this story Miss Poynter passes from her pleasing childish fancies to the highly emotional woman in excellent fashion.

Miss Poynter makes the play one of powerful human interest and worth while, and it is especially in the final scene that Miss Poynter is most effective.

REVIVING THE DAYS OF PERIWIGS AND DUELS IN "SPRINGTIME" (ALCO-LIFE PHOTO FEATURE)



THE DUEL



FLORENCE NASH



WAITING BY THE RIVER

Motion Picture News

HAS THE QUALITY CIRCULATION OF THE TRADE

MOVING PICTURE NEWS EXHIBITORS' TIMES
Published Every Week by

EXHIBITORS' TIMES, Inc.

New York Offices 220 West 42nd Street
Chicago Offices.....223 West Jackson Boulevard
Los Angeles Offices.....427 South Figueroa Street

WILLIAM A. JOHNSTON.....President
HENRY F. SEWALL.....Vice-President
E. KENDALL GILLET.....Secretary
H. ASHTON WYCKOFF.....Treasurer
WENTWORTH TUCKER.....Ass't Treasurer.

WILLIAM A. JOHNSTON.....Editor
LESLEY MASON.....Managing Editor
WILLIAM RESSMAN ANDREWS.....News Editor
H. ASHTON WYCKOFF.....Business Manager
R. M. VANDIVERT.....Advertising Manager
E. J. HUDSON.....Circulation Manager
THEODORE S. MEAD.....Chicago Manager
J. C. JESSEN.....Los Angeles Manager

This publication is owned and published by Exhibitors' Times, incorporated under the laws of the State of New York. The offices and principal place of business are at 220 West 42nd Street, New York City. The address of the officers is the office of the publication.

Entered as Second-Class matter at the New York Post-Office.

Subscription \$2.00 per year, postpaid in the United States, Mexico, Hawaii, Porto Rico and the Philippine Islands. Canada, \$3.00; Foreign \$4.00 per year.

ADVERTISING RATES ON APPLICATION.

Copy for next issue must reach us by Tuesday, 5 p. m.

Cuts and copy are received subject to the approval of the publishers and advertisements are inserted absolutely without condition expressed or implied as to what appears in the text portion of the paper.

Vol. X December 5, 1914 No. 22

Two Organizations and the One for the Motion Picture Exhibitor

THERE are two organizations at the present time in this field, bidding for the exhibitor's support.

One is The Motion Picture Exhibitors' League of America—an all-exhibitors' body, of the exhibitors and for the exhibitors.

The other is the United Managers' Protective Association, an organization until very recently composed of the legitimate, vaudeville and burlesque interests, which only at the last meeting were any motion picture men invited to join, and these only the leading manufacturers.

This latter body has now undertaken to enlist all the motion picture exhibitors of the country under its banner. It has sent paid organizers into the field. It is making a canvass by mail and by missionary work in every State to ascertain the willingness of the exhibitors to make the United Managers' Protective Association their body.

* * *

ANYONE who did not know conditions in this industry would declare that no exhibitor in his right mind would dream of allying himself with an organization outside of, and very largely antagonistic to his own business.

Yet there are not a few exhibitors, supposedly in their right minds, who have not only listened to the invitations of the United Managers, but have all but pledged themselves to affiliate with them.

HAVE these exhibitors answered satisfactorily the question, "What will this organization do for me?" Have they even asked themselves that question? If they have not, it is time they did. And while they are in that frame of mind, here are a few other questions they may profitably ask themselves, to avoid repenting at leisure what they are about to do in haste.

* * *

EXHIBITORS have their own peculiar problems, which from the very nature of this business, are not to be found or paralleled in the world of the stage.

Will an association composed of and controlled by men outside the motion picture business do anything to satisfy the needs of their exhibitor members, except where those needs happen to coincide with their own?

Will the United Managers assist the exhibitor to solve the problem of higher prices?

Will the United Managers assist the exhibitor to solve the problem of film rentals?

Will the United Managers assist the exhibitor to fight legalized censorship?

Will the United Managers assist the exhibitor to eliminate cut-throat competition and reduce his business to a solid, substantial and efficient basis?

* * *

WILL the United Managers assist the exhibitor to fight hostile legislation, unless that legislation affects the legitimate, vaudeville and burlesque interests as well as those of the motion picture?

And, finally, will the exhibitor be better satisfied among men who are either competitors of or strangers to his business, than he is among his own kind, whose interests are identical with his?

If exhibitors can not live in harmony in an organization made up solely of exhibitors, can they expect to live without bickerings, brawls and battles in an organization where they are always in a minority, and where they will have the pleasure of seeing their problems and needs continually pushed aside for those of the stronger party?

* * *

THAT any exhibitor should consider it necessary to go outside of his own field to find an organization he is willing to support is a confession of a total lack of common sense and business judgment on his part.

Not one of the services which the exhibitor who joined the United Managers would have a right to expect from them, but could and would be more efficiently performed by the Motion Picture Exhibitors' League.

* * *

THESE things have not been said with malice or prejudice, but simply in a spirit of justice to the exhibitors whom MOTION PICTURE NEWS is bound to serve.

The United Managers' Protective Association does not need the exhibitor any more than the exhibitor needs the Association.

The Best "News" You Ever Received

EVERY issue of "Motion Picture News" is "good News" to the live-wire exhibitor—the man to whom exhibiting pictures is the vocation of a lifetime.

But the issue of December 19 will be an eye-opener from the front cover in colors to the last line of the publication.

The Christmas number of "Motion Picture News" will mark an epoch in special numbers in this field. In arrangement, contents and value it will set a new mark. No extra copies can be had after December 8.

Don't be a watchful waiter. See to it that you get all the copies you want—you'll want all you can get.

Women Will Act as Censors in Detroit

It Is Practically Decided That the Club Federation Will Be in Charge of Film Supervision in Michigan City

Special to MOTION PICTURE NEWS

Detroit, Nov. 24.

SINCE the first of last July, Detroit has been without an official censor, owing to the fact that the board of estimate would not make an allowance for the same in the appropriation asked by the police department. The police department has made no attempt, except in one or two cases, to pass or censor in any way picture films, although plain clothes men, as well as the regular policemen, have been expected to report any films which, in their opinion, were unfit to be on public exhibition. It is a fact the police department received very few complaints.

Theatre managers and proprietors, outside of a few, have had the interests of their patrons at heart and would not permit indecent and immoral pictures to be shown.

At a meeting of a committee from the Detroit Federation of Women's Clubs and secretary of the police department, George A. Walters, it was practically decided that the Detroit Federation of Women's Clubs should take charge of the censorship of

motion pictures in this city, pending the active organization of the recreation committee, provided for by a charter amendment adopted in the November 3 election.

When the committee called on Secretary Walters, November 12, the members were informed that there wasn't any censorship of picture theatres; that improper films have been shown by a number of downtown theatres, and that the general tone of films has been below that maintained while Lester Potter was on censor duty.

The club women volunteered to act as censors, and Secretary Walters assured them that they would be most welcome. He explained that the police department had submitted estimates for a censor, an assistant censor and a motion-picture machine operator, but that the board of estimators had cut all of the items, causing the department to abandon censorship.

He explained that if the club women found instances of improper conditions, they might notify the department, which would gladly send officers to investigate the complaint and to see that the conditions were remedied.

BRODERICK WITH DYREDA

Robert Broderick, leading man of the Dyreda Art Film Corporation, who are using the old Reliance Studios at Yonkers, N. Y., has an international reputation as an actor, having played with such stars as Francis Wilson, Virginia Harned, Thomas Jefferson and many others.

Mr. Broderick's first advent into the pic-



ROBERT BRODERICK

California Solons Ready for "Regulation"

Huge Batch of Uplift Bills, Including One Providing for Three \$2.50-a-Day Censor Jobs, Will Be Considered

Special to MOTION PICTURE NEWS

Los Angeles, Nov. 23.

THAT freak bills for the "regulation" of the motion picture exhibitions will be introduced at the coming meeting of the California assembly in January has become known.

One of these, now filed for public examination, provides that following the projection of each reel of pictures the lights of the theatre shall be turned on and remain lighted for five minutes, in order that the eyes of the patrons may have an opportunity for rest.

A change in another proposed piece of legislation, referred to in a previous article in MOTION PICTURE NEWS, relative to the establishment of a state board of censorship, with offices at the state capital, Sacramento, from which point all pictures must be released, provides that a charge of \$2.50 shall be made for the examination of each reel, and that the board of censors shall consist of three members, one to be selected by the Federation of Women's Clubs, one by the state ministerial association, and the third by the state association of school boards.

These proposed bills, together with the others—prohibiting admission to children under 16 years of age, unless accompanied by parents or legally appointed guardians; permits from state board of censors revocable at their pleasure, for the operation of a motion-picture theatre, and the state censorship bill as originally prepared—are the chief topics of conversation when two or more exhibitors or exchange men meet.

The preparation of these bills and their exhibition are proving to be a good cause for the Exhibitors League, and will result

in strengthening the organization wonderfully in every part of the state. The membership is growing every week.

J. C. JESSEN.

NAVAL RESERVES PLAY IMPORTANT ESSANAY PART

The Illinois naval reserves play an important role in the Essanay drama, "Every Inch a King." Several of the scenes in this play, which is released December 11, are taken aboard the cutter *Dubuque*. Francis X. Bushman takes the leading role in the play, but the reservists play an important part in forming the lesser characters.

ARNOLD IS NEW LIFE-PHOTO CAMERA MAN

John Arnold, vice-president of The Cinema Club, has been engaged as head camera man by the Life-Photo Film Corporation, the new producing ally of Alco. Mr. Arnold left with the company, which went to New Orleans to produce Booth Tarkington's "Springtime" in its original setting. Mr. Arnold is one of the pioneers among motion picture camera men.

ARE YOU USING IT? THESE MEN ARE. SEE PAGE 51

"It is O. K."—W. C. SUTTON, Bijou Theatre, Xenia, Ohio.

"It is a good idea and seems very complete."—H. W. HEILBERGER, Lehigh Orpheum Theatre, South Baltimore, Pa.

ture game was with the Kinemacolor Company, on the coast, where he wrote and played the lead in the old fable, "Jack the Giant Killer." His portrayal of that difficult character was so excellent that he was made an offer by the Western Kalem Company, which he accepted. He then came East and joined the Eastern branch of that company, and from there to the Famous Players Company. When J. Searle Dawley left the Famous Players Company to form his own company, the Dyreda Art Film Corporation, he took Mr. Broderick with him as his leading man.

The Dyreda company up to the present time have made two big features in which Mr. Broderick has played the lead. These pictures are being released through the World Film Corporation.

The first picture, a four-reel subject, "One of Millions," has already been released. The other feature, "In the Name of the Prince of Peace," in four reels, will be released in November.

CHILDREN LIKE THE PATHE CARTOONS

Manager Hudson, of the San Francisco office of the Eclectic Film Company, recently received a note from Mr. Roth, of the Portola theatre, enclosing a letter he had received from a little girl in regard to the Pathe animated cartoons by Bray. The letter is worth quoting:

"San Francisco, Oct. 31.

"Dear Mr. Portola:

"I am a little girl 10 years old. My brother and I were at your pitcher show one night and we liked that one where the elephant chased a man up the mountains. Please have some more like this.

"Yours truly,

"VIOLA RANSOME."

AMONG THE EXCHANGES

SKIRBOLL ACTIVE IN PITTSBURGH TERRITORY

JOSEPH SKIRBOLL, general manager of the Chicago and Pittsburgh Alco exchanges, paid a visit the other day to the Alco Film Corporation's office in Forty-second street. He reports that the demands for big features in Chicago and Pittsburgh are steadily increasing. In both places features plays are put on for runs of several weeks.

Mr. Skirboll has added many new theatres to his list in his territory. The new Regent theatre at East Liberty just completed at a cost of \$100,000, has signed the Regent for the entire Alco program. The theatre opened with "Salomy Jane" as the attraction. The management did extensive advertising. It got out booklets dealing with this first production of the California Motion Picture Corporation and other attractive advertising matter.

Mr. Skirboll has also added the William Penn theatre, of Pittsburgh, to the number to which he is supplying regularly the Alco programme.

CHANGES AT WASHINGTON EXCHANGES

SOME changes have taken place at the exchange offices in the Capital City. Mr. Anderson, of the Greater New York Film Exchange, has added the Box Office Attraction films to his program and has been able to place these films in important theatres.

J. A. Koepel has recently become manager of the General Film offices in Washington. As he is a man who believes in the productions of a corporation being its best spokesman certainly the popularity of the General Film program in Washington is ample proof of its quality. Its features are especially in demand.

H. M. Osborn has succeeded C. L. Worthington as manager of the Eclectic offices. He reports conditions very favorable and announces S. M. Flax, formerly of Warner's Features, to become the road man for his offices. Mr. Worthington has associated himself with the Box Office Attractions of Philadelphia.

ALCO OPENS KANSAS CITY OFFICE

THE Alco Film Service have opened an office in the Gloyd building, Kansas City, Mo., suite 317-318, under the management of William Reichman, who came here from their St. Louis office. Their entrance into this field with up-to-date productions will meet aggressive competition, as all the high class firms are represented in this territory.

The fall trade in the West has shown an increasing demand for moving pictures, and

in fact all lines of business are flourishing. This condition is a natural result of abundant production of food stuff, and at very satisfactory prices, caused, of course, by the struggle of our unfortunate ancestors "across the pond."

There is a decided increase in the demand for the better class of productions, and higher grades of all equipments.

BLINKHORN OPENS COAST OFFICE

THE Blinkhorn Photoplays Corporation has established Pacific Coast headquarters at Mason and Market streets, San Francisco, Cal., in the Mechanics' Bank building, the new branch being in charge of C. L. Williams, formerly of this city, but located for several years past in New York.

Large offices have been established on the sixth floor of this building, and an unusual feature, for San Francisco at least, will be an upstairs exhibiting room. An operating booth is being fitted up, and this will be in operation within a short time. Some film has already been received, and advance bookings have been quite satisfactory. It is the plan of this concern to open several branches in this territory as soon as the main office is running smoothly, these to be at Los Angeles, Denver and at either Seattle or Portland.

MAY REPRESENT ONE OF NEWER COMPANIES

E. R. MENCEL, better known as "Dick," one of the oldest road men out of Minneapolis and formerly with the Mutual, Universal and World Film companies, has resigned his position with the last named firm.

After a few weeks' recuperation he will return to the Twin Cities, probably as representative of one of the newer programs.

WORLD INCREASES STAFF IN ATLANTA

ARTHUR S. HYMAN, manager of the Atlanta branch of the World Film Corporation, has found that the increase in his business has made necessary additions to his forces.

Thomas F. McTyler has been secured as road man, and a special feature department has been added by Manager Hyman.

EXHIBITOR WILL JOIN EXCHANGE

HARRY NAUGLE, who has been manager of Clune's Broadway Theatre, Los Angeles, has tendered his resignation to take effect in the near future and will accept a position as assistant to Manager Harry H. Hicks of the Los Angeles General Film Company exchange.

FROM PITTSBURGH EXCHANGES

MAYER SILVERMAN, who went to New York on business several days ago, has returned to Pittsburgh. Silverman is of the Liberty Renting Film Company. While in the East he closed for "The Great Train Robbery," a four-reel feature, and he states he has other productions under consideration. Mr. Silverman announces the following will be ready for release: "Saints and Sinners," four reels; "The Woman He Wronged," five reels, and "When London Sleeps," four reels.

Adolph Klein, of the Keno Feature Film Company, has added a number of big features to his already large list.

Although he has been in his new office but a few weeks Harvey B. Day, local manager of the Box Office Attractions Company, has already had the carpenters busy remodeling his new plant. He states that it is necessary for him to have more room on account of the expansion of the business and the many new reels that will be shipped in each week.

NASMITH HANDLING STATES RIGHTS

WILLIAM J. NASMITH, who was formerly in Chicago in the exchange business, is back in that city once more and this time selling the rights to feature films. After leaving Chicago Mr. Nasmith went with the "Universal Weekly" and left that company to become associated with the Progress Feature Film Company.

Lately he has had charge of the Eighth Avenue and Burland Theatres, two of the largest photoplay houses in Manhattan and Bronx.

Mr. Nasmith announces that he has the states rights for Illinois and neighboring states of several big features of current releases.

MONTREAL EXCHANGE SIGNS LIFE PHOTO RELEASE

THE Equitable Film Exchange, the head office of which is in Montreal, has just completed negotiations with the Life Photo Film Corporation of New York City, to release in Canada all its features.

The following are the first of the series: "The Ordeal," "The Banker's Daughter," "Capt. Swift," "Northern Lights," and "The Greyhound." Mr. Roskam is the manager.

CRONE VISITS LOS ANGELES

J. R. CRONE, manager of the Pacific Mutual exchange at San Francisco, and who was formerly of Los Angeles, spend a week there in conference with Manager Johns of the Los Angeles exchange.

NEW WORLD FILM MANAGERS

GENERAL Manager Lewis J. Selznick, of the World Film Corporation, announces the appointment of Frank H. Vine as manager of the New England branch of the World Film Corporation, Robert Etris, manager of the Philadelphia branch, and H. C. Holah, manager of the Cleveland branch.

Frank H. Vine is one of the best known figures in the motion picture trade in New England. For four years he was the manager of the Boston office of the General Film Company. Previous to that he was the manager of the Howard Moving Picture Company.

When the Eclectic Film Company decided to open exchanges throughout the United States, Mr. Vine was made manager of the Pittsburgh branch, and he organized the staff for that office. In August, 1913, he was transferred to the management of the Eclectic branch in Boston, and has remained there to this day. He took charge of the World Film office there on November 23.

SHILDS SUCCEEDS DAVIE AT WOLVERINE

H. R. SHILDS has succeeded Charles M. Davie as manager of the Wolverine Feature Film Company, Campau building, Detroit. Mr. Shields has had considerable experience in the moving picture industry, having for the past few months been acting as assistant to Mr. Davie, previous to which time he was representative on the road for the Mutual Film Corporation.

Wesley Schram is president of the Wolverine company. He is also manager and financial stockholder in the Monroe Theatre, on Monroe avenue, Detroit. Early in November he went deer hunting in the northern part of Michigan, and will be back Thanksgiving Day.

ALLIANCE PICTURES IN DEMAND

MESSRS. MARCUS AND WILLIAMSON, managers of the Mission Theatre at Santa Barbara, which they are remodeling to give accommodations to 1,000 instead of 500, were in Los Angeles this week and contracted for Alliance features for the last four days of each week, through H. E. White, manager of the Nat A. Magnar exchange.

Another contract, first made for a short time and now increased to one year, is that made by Bert Lustic, manager of the National Theatre, for first run of Alliance releases in Los Angeles.

BORIES PLANS TRIP TO LOS ANGELES FOR SCREEN CLUB BALL

LEON BORIES, manager of the San Francisco office of the General Film Company, will make a trip to Los Angeles shortly and while there will make arrangements for the presence of a number of moving picture stars of the first magnitude at the Screen Club ball, which is to be given in the Coliseum, San Francisco, on November 28.

It is believed that it will be necessary to charter a special train to bring the visitors from the Southland.

Montana Relieves Exhibitors of Tax Burden

Supreme Court Hands Down Decision Against City Licenses as State Already Exacts \$25 a Year Assessment

Special to MOTION PICTURE NEWS

Butte, Mont., Nov. 23.

MONTANA cities cannot validly tax a motion-picture house in this state for a license in excess of the annual tax of \$25 charged by the state, according to a decision of Judge Albert P. Stark, of the district court, in the case of the city of Livingston against E. P. White, a Livingston picture-house proprietor.

The decision is of interest to every exhibitor in the state. The case will be brought to the supreme court for reversal by the authorities of the city of Livingston. This is the first test case in this state. It is understood that various cities have been waiting to see the success of the move by the city officials of Livingston. A law

passed at the last session of the Montana legislature, setting a tax of \$25 on picture houses and guaranteeing those houses certain rights on payment of the tax, was also held constitutional in Judge Stark's decision.

The city council of Livingston passed an ordinance a year ago taxing Livingston picture houses \$30 per quarter. White objected, and the case was made a test one. Exhibitors throughout the state will await with much interest the decision of the supreme court, which, however, may not be given for some months yet. It is understood that the matter will not rest here. The general feeling among picture men is that the decision of Judge Stark will stand.

JAMES CUMMINS.

Los Angeles Company Ceases Production

Usona, First Affected by War, Was Releasing in Europe Exclusively—Burton King Declares Market There Is Badly Hit

Special to MOTION PICTURE NEWS

Los Angeles, Nov. 23.

THE first producing company of the Los Angeles motion picture colony to announce a close-down because of the European war is the Usona company, composed of Los Angeles parties, who have been releasing in Europe.

The producing end of this company was in charge of Burton King, and for months it has been known as the "mystery film company," as no one knew the releases, and it was believed here all the fifty-odd reels of negative made had been placed on the shelf.

It now develops that all negative was

shipped direct to England, where the positive factory was located. A majority of the subjects went big, according to reports, the most successful being "Mother's Birthday," from which one hundred and forty-two prints were made and sold. The name role of this picture was taken by Eugenia Forde, well known as Rosamond in the "Desperate Desmond" comedy series, of several years ago. The son and daughter parts were played by Robyn Adair and Virginia Kirkley.

According to reports received by Mr. King, direct from England by cable, the market there is badly hit, and further releases will cause losses.

FIRST FOUR ALL STAR FILMS TO BE HANDLED BY CASINO

THAT there may be no misunderstanding as far as Michigan is concerned, the Casino Feature Film Co. will handle the first four releases of the All-Star Producing Company, which have or will come out since October 5.

Outside of these four attractions the complete Alco program in the state of Michigan will be handled by Charles M. Davie, who has just opened offices at 260-262 Equity building, Detroit. Some houses have been under the impression that Mr. Davie would also handle the All-Star productions, but he desires to correct any such impression as above mentioned. The first release in Michigan was "Salomy Jane," which appeared at the Empire, Detroit, Monday and Tuesday, November 23 and 24.

WARNER'S CHICAGO, IN NEW OFFICES

WARNERS' FEATURES are installed in their new offices at 17 North Dearborn street, Chicago. These roomy, well appointed, beautifully furnished offices are a flattering tribute both to Warners' Features and to D. J. Chatkin, the manager of the Chicago Exchange.

BRACKETT GETS SOUTHWEST FOR BUFFALO BILL FILM

ROBERT BRACKETT, of Los Angeles, who has had charge of booking the Buffalo Bill Indian War feature in California and Arizona, has been very successful with the production, so much so that the owner, Historical Film Company, of Chicago, has allotted him additional territory. In the future he will have charge of all booking in Colorado, Utah, Nevada and New Mexico, in addition to this state and Arizona.

HALL IN CHARGE OF DES MOINES OFFICE

MANAGER PAT J. HALL, of the Ramo Film Company, is handling its Des Moines, Iowa, office. Mr. Hall is well known in the western field, and was formerly connected with the territory of Denver and Salt Lake City.

LOWRY GOES TO COAST

IRA M. LOWRY, general manager of the Lubin Manufacturing Company, left last week for a trip to the Pacific Coast. Mr. Lowry will combine business with pleasure, devoting considerable attention to the Lubin plant at Los Angeles.

The Exhibitors' Forum

MOTION PICTURE NEWS assumes no responsibility for any opinion or assertion made in the columns below, nor does the publication of a letter mean that the statements it contains are endorsed by the NEWS. All letters must be signed. No attention will be paid to anonymous communications

Exhibitor's Hint to Reviewers

Editor, MOTION PICTURE NEWS,
New York City:

Dear Sir: Your editorial of November 28 on real quality is assuredly a timely one and the last paragraph is something every reviewer should ponder over. "Why don't you put the exhibitor on guard against such productions?"

Well! Why don't you? The inland exhibitor is obliged to judge his features from the reviews, and his advertising is almost entirely governed by his deductions, which nine times out of ten is most favorable.

Did you ever read a review that was not a boost for any old kind of a big feature? I have before me now two reviews of a standard feature which I just played a few nights ago; one said the picture was lacking all those things that make a big picture—the other said the exhibitor could go as far as he liked boosting; after exhibiting I found out that the latter was right.

Now the man who roasted that picture discredits the profession to which he belongs.

But to get back to the main question. How is the exhibitor going to determine which is the real from the near feature? Not from the general views in the numerous magazines, because they are all "good" in them.

Under present conditions the exhibitor, if hooked up with some standard features, should under no consideration, nibble at the alluring baits of wild cat features.

An editorial directed to the small town exhibitor would be of wonderful assistance in future guidance, for no writer ever thinks further than conditions in New York City.

OLD TIMER.

President Beach on Program Troubles

Since the manufacturers of feature film attractions have entered the field on such a large scale, and it has become necessary for almost all exhibitors to show these features from time to time, in order to vary their programs, theatre owners have complained bitterly of the manner in which film exchanges insist upon payment for a full program, whether it is desired in its entirety or not.

In a communication to his fellow exhibitors, President H. L. Beach, of the California State League, says:

"To undertake to run a show with the regular program means stagnation; to run features alone means lack of variety; therefore we see the need of both, and the suc-

cessful exhibitor must have both in order to satisfy his patrons.

"One of the greatest problems an exhibitor has to meet in the show business is to keep his patrons satisfied and to keep them coming; therefore it must be clearly seen that the exhibitor must have freedom in selecting that which brings him the greatest success, and to have success an exhibitor must have both variety and strength to his program. Under the present conditions the exhibitor is caught between the two factions, and is like being caught between two great millstones—he is being ground exceedingly fine.

"The regular program exchanges seem to feel that they have a first mortgage on the exhibitor, by reason of priority in the field, while on the other hand, the feature man feels that he also has his money invested and desires to make a living, and by the very nature of his productions the price per reel must exceed that of the regular program.

"Now, if the exhibitor has to pay his regular daily service and pay an advanced price per reel on features, taken altogether he frequently finds himself in the hole on the day's business, with the total sum of having worked all day for the film exchanges. To solve this problem exhibitors must have freedom in contracting with exchanges, as their needs require a liberal policy. Surely this will benefit all. What the exchanges desire most is to deal with a prosperous exhibitor, for he does not hesitate to buy good films and pay a fair price. Let our motto be, "Live and let live."

6000 Feet of Film Stolen

Minneapolis, Nov. 16.

Editor, MOTION PICTURE NEWS,
New York City.

Dear Sir:—We have had the misfortune of losing a package of films which was stolen on November 7 from the American Express Company, addressed to Mr. John Masgai, Worthington, Minn. The subjects in question are:

"Their Honeymoon" (Nestor), 1,000 feet; "The Test" (Nestor), 1,000 feet; "Our Daughter" (Eclair), 1,000 feet; "Discord and Harmony" (Bison), 3,000 feet.

As already stated, this package was stolen from the American Express Company's wagon after leaving this office on November 7.

Any publicity you can give or allow will be greatly appreciated, I assure you.

Respectfully yours,
THE LAEMMLE FILM SERVICE.

A Protest Against the Average Comedy

Kansas City, Mo., Nov. 17, 1914.

Editor, MOTION PICTURE NEWS,
New York City.

Dear Sir: Among the severe criticisms of features on exhibition the past few weeks, is the increasing exploiting of scenes in which the infants take a prominent part. The finer feelings of mothers, fathers, brothers and sisters especially, are shocked by the distress, weeping and real sobbing of the little babies, often in the hands of persons not accustomed to handling the little tender ones.

The real thrills of a well-staged drama or emotional play are not produced by distressing a helpless, tender baby.

Eliminate the error, and let us have the laughing, cooing, little ones, or not at all.

Most of the alleged comic plays now produced are too rotten even for the smaller towns. As a matter of fact there is only one production that is in the slightest entertaining. The rolling, tumbling policeman, running over house-tops, the usual plunge in water, and many others of like nature, are getting so stale they are disgusting instead of amusing. Let us have something new or drop them out entirely.

EXHIBITOR.

[Many of the objections made by "Exhibitor" are well taken, but he should remember that the tendency is toward improvement.—EDITOR.]

Casino Has First Four All-Star Features

THE CASINO FEATURE FILM CO.
2206-2211 Dime Bank Building.

Detroit, Nov. 14.

Editor, MOTION PICTURE NEWS,
New York City.

Dear Sir:—I note in your issue of November 21 an announcement to the effect that C. M. Davie has obtained the franchise for the entire Alco program for Michigan.

We would thank you to correct this statement, inasmuch as we have the exclusive rights for the next four All-Star releases, including Ethel Barrymore in "The Nightingale," "Shore Acres," Digby Bell in "The Education of Mr. Pipp," and the release following that. We have also an option for a year following these releases, and any announcement to the effect that the Alco exchange in Michigan controls all Alco productions is a misstatement of facts.

Yours very truly,
CASINO FEATURE FILM CO.,
H. GOLDBERG.

FEATURE "WHEEL" IS PLAN OF CINCINNATI EXHIBITORS

New Organization Closes Deal with Box Office Attractions for a Series of Multiples to Be Shown at Association Houses Before They Are Released to Other Theatres—Each Feature Will Run Ten Days Before General Release—South Dakota Exhibitors Fight Sunday Law

Special to MOTION PICTURE NEWS

Cincinnati, O., Nov. 25.

THE Exhibitors Managers' Association, the new organization of Cincinnati film men representing 10 motion picture theatres of the city, this week closed one of the biggest deals for feature attractions in the history of the city.

At their meeting in the Savoy hotel, the ten members of the association signed agreements by which features of the Box Office Attraction Company will be furnished to these houses for an indefinite period. Mr. Colby, representing the film company, stated that an office will be opened in Cincinnati within a few weeks, and programs will be then furnished to the members of the organization.

It has been so arranged that the features will start at the Alhambra, President Charles Weigel's theatre, and rotate, according to the plans of the organization, through the other houses represented in the membership.

Each Feature to Run Ten Days

Each feature therefor will have a run of ten consecutive days before it will be available for release to other theatres. Theatres represented in the organization are located in different sections of the city, so that the releasing arrangement appears to be an ideal one.

The first of these features, all of which will be five or six reels in length, will be "St. Elmo," it is announced. This is to be followed by "Life's Shop Window" and other pictures of similar character. The association has made similar arrangements for first releases of the Alco and Shubert-Brady features through Clay E. Brehm, manager of the World's Special Film Corporation here.

Charles Weigel, manager of the Alhambra, is president of the organization; A. G. Hettesheimer, manager the Orpheum, vice-president, and Harry Kruse, manager the Park Theatre, Northside, secretary.

Downtown Business Is Booming

Business among exhibitors is reported as fair, considering the fact that many workmen in the factory districts are idle as the result of the general business depression. Interest in the better grade of pictures has naturally increased with the arrival of cold weather. Downtown theatres are playing to exceptionally fine houses, but those of the suburbs are not doing as well as had been expected.

Arrangements for the opening of the new Strand Theatre, under the management of Isaac Libson, on Thanksgiving Day are being completed. The Strand is to be the rejuvenated Gayety Theatre, formerly a high class burlesque house, which will now be devoted to feature films. The Keith interests are behind the new house. It is the largest exclusive picture theatre in the heart of the city, and it is confidently expected that under the man-

agement of Mr. Libson will be immeasurably successful.

Decorators have been busy during the past two weeks rearranging the paintings in the lobby and auditorium. Huge signs announcing the opening of the new theatre have been built around the lobby and completely hide the workmen from view of pedestrians.

The Gayety was the newest theatre building in Cincinnati, and the construction of the auditorium was after the most modern plans. No announcement has yet been made of the programs which it will offer, although it is intimated that the General Film Company will furnish the greater part of the program. ROE S. EASTMAN.

EXHIBITORS FIGHT SUNDAY CLOSING LAW IN SOUTH DAKOTA; CASE IS IN COURTS

Special to MOTION PICTURE NEWS

Minneapolis, Nov. 25.

EVER since motion pictures were exhibited there has been constant wrangling about Sunday shows in various South Dakota towns; some towns are permitted to run on the Sabbath day providing the subjects exhibited are of a scenic, educational or industrial order; in short, most any motion picture which contained no acting or special stage settings were considered appropriate on the day of rest.

At the present time the exhibitors of

Aberdeen, S. D., are having a fight on their hands. A few weeks ago they commenced to run Sunday performances which in every detail complied with the requirements of the Sunday laws; one by one each manager has been arrested, and on two separate counts.

In one case the exhibitor lost out in Municipal Court; carried it to Circuit Court, and also lost out there, and this has now been carried to the Supreme Court of the State. The other exhibitors have been able so far to keep their cases in the Municipal Court as they cannot get a jury to agree.

If the Supreme Court upholds the decision of the Circuit Court it will close every picture show on Sunday in the State of South Dakota, and in some towns such as Sioux Falls they have been running for seven years.

The Aberdeen bunch are determined to make this a test case, and an article was inserted by the theatrical proprietors of Aberdeen, and appeared in the Aberdeen *Daily American* of November 6.

The Aberdeen exhibitors are making such heroic efforts to win their cases that every exhibitor in the Northwest, in fact the entire United States, should lend a helping hand to these fellow exhibitors, and C. T. Smithers, in care of the Idle Hour Theatre, Aberdeen, South Dakota, will be very glad to hear from any one who might have one or the other suggestion to offer. FRED S. MEYER.

Elizabeth Conditions Forecast Business Boom

Exhibitors Feel Good Effects of Action of Singer Sewing Machine Company, Which Is Now Taking Back Operatives

Special to MOTION PICTURE NEWS

Elizabeth, N. J., Nov. 25.

LOCAL theatre managers are unanimous in the belief that the falling off in business that accompanied the beginning of the European war will have but little effect on the future theatre patronage in this city.

Everyone reports that during the past two weeks conditions have materially improved. The laying off of several thousand men at the Singer Sewing Machine plant here and the enforced idleness of hundreds of employees of other manufacturing concerns, were more keenly felt by the moving picture houses than by playhouses that staged other forms of entertainment.

Several managers declared that during the months of August, September and October the attendance dropped off fully 50 per cent. During the present month, however, there has been a gradual restoration of normal conditions until at the present time attendance figures are but little smaller than characterized the pleasing conditions that existed before the advent of the European conflict.

The Singer company has begun taking back hundreds of those who were laid off and better industrial conditions are re-

ported from other sources throughout the city. At the Garden Theatre this week all attendance records have been broken by the capacity crowds that greeted Mary Pickford in "Behind the Scenes." Proctors' Broad street theatre and other motion picture houses report improved conditions of patronage that argue well for a profitable winter season. FRANK M. BOYCE, JR.

HANDWORTH VISITS NEW YORK

The director of the Excelsior Film Company found time to run down from Lake Placid to New York for a day or so last week. Harry Handworth was happy as usual and of course busy. He said he had found time to come to town as the next production of the Excelsior was already completed. Mr. Handworth felt that he deserved a well earned rest.

The finest issue ever published of a motion picture trade paper will appear under date of December 19. SEE PAGE 102. No orders for additional copies can be taken after December 8.

STRIKING FIGURES AND SCENES FROM THE SECOND EPISODE OF THANHOUSER'S NEW SERIAL



THE CHIEFTAIN

OVERCOME IN THE "SLEEPING HOUSE"

ZUDORA AND HER ATTENDANTS

CAUGHT!

"ZUDORA"

(Thanhouser—Second Episode)

REVIEWED BY PETER MILNE

EVEN if the witness of "The Mystery of the Sleeping House," the second episode in the adventures of "Zudora," finds it slightly unfathomable until the termination of the first thousand feet, his interest will be so well sustained by the remarkable atmosphere of mysticism and secluedness which pervades the film that the little complexities in the plot itself will pass unnoticed.

Such delightfully mystifying situations which are continually presenting themselves throughout the two reels, seeming for the reason all too short, were not bettered to any great extent in Zudora's famed predecessor, "The Million Dollar Mystery."

It was not our good fortune to pass judgment on Zudora number one, and so if the actions of the characters, and even the characters themselves, seem, in the beginning, rather obscure, it is because of our negligence, not the fault of the picture. But let the point be made clear that after the action has gained headway, after we have become acquainted with the various members of the cast, and after a few mystic situations have been led up to and developed, the why and whereof of the story is as clear as the sun's rays, and like the sun's rays, again it fairly dazzles with elaborately gorgeous settings and costumes.

But there are other things to awaken and enliven the senses, however dull they may be. When we see Storm, the handsome hero of the story enlocked in a contracting cell with the walls slowly closing in about him, we are seized with abject fear and anxiety that Zudora will not reach the giant Nubian slave who is turning a crank which is closing the walls, in time to save her lover.

She accomplishes this in grand style, however, and the two are united again, ready to start on the next adventure. The way Storm arrived in the cell was the result of a search for Zudora, who had gone to a Hindu den to fathom a mystery allotted to the mind of her guardian. He, however, gives the problem to Zudora to solve, as one of the twenty she has to complete in order to receive his permission to marry Storm.

She only emerges from her perils triumphant after the most trying circumstances, which are calculated to create suspense, and this they certainly do, in a most effective style. In the class of mystery stories, this episode of "Zudora" is most certainly one of the best in every degree.

"THE WALLS OF JERICHO"

(Box Office—Five Reels)

REVIEWED BY PETER MILNE

IF one is not familiar with the fact that "The Walls of Jericho" was formerly a stage success, the conclusion might be that the story was laid back in biblical times, but such is not the case. Distinctly modern in nature, "The Walls of Jericho" mean in reality the walls of social cynicism and hypocrisy, which, thanks to the author, fall down with a crash in the end of the picture, much, as the Bible tells us, resembling the downfall of the walls of the ancient city, when the Israelites blew their trumpets.

As a stage production "The Walls of Jericho" achieved great success, both in New York City and throughout the country at large. In its visualized state it is sure to entertain and enthral many thousands of persons, even more, perhaps than its illustrious

forerunner. It is said that Alfred Sutro, the author of the play, was more than satisfied when he viewed the production in its finished state, so if the author is pleased with his own story in a picturized form, it is safe to surmise that the public will be equally satisfied.

After a somewhat lengthy introduction, showing the habits and characteristics of two miners in our own west, we see one of them, an Englishman, Jack Frobisher, forced to flee to his own country from a crime which he did not commit. Here he falls heir to his father's vast estates, and soon after marries Lady Althea, an English society woman. The rest of the picture is taken up with illustrations of the false and hypocritical ways of society. His wife succumbs to the wiles of a corrupt English society man, and is openly denounced by her husband, but even then he still purposes to keep her, and straightway unveils her eyes to the evil of the man she thinks she loves. This man, in league with an enemy of Frobisher from the States, accuses him of the crime he was supposed to have committed, but the sheriff steps in just in time to tell the truth.

Edmund Breese interprets the role of Frobisher in a way which calls for no unfavorable comment. He is immensely strong as an out of the ordinary Englishman, possessing a character and man-



THE MARRIAGE OF FROBISHER AND LADY ALTHEA

ner of going about his business with a determination to get to the bottom of things, effected by the quick and decisive ways of one who has received hard knocks in a previous life as an American miner.

Claire Whitney is so well suited to the role of his wife, that it seems as if Lady Althea were a part especially created for her. Stuart Holmes has an unsympathetic part as the idle Englishman, which suits him remarkably well. Edward Jose appears to good advantage as the claim-jumper who attempts to accuse Frobisher of murder, but is finally arrested on that charge himself. The rest of the cast is good.

The photography of the offering is very good and the scenes and sets realistic. Credit should be allotted to Lloyd B. Carleton, who directed the picture, and to all others who were concerned in the making of it.

"FOR THE MASTERY OF THE WORLD"

(Eclair-Universal—Three Reels)

REVIEWED BY PETER MILNE

THESE reels follow as a sequel to "Adventures in Diplomacy," a three-part subject released a short time ago by the Eclair Company. The same characters appear, and although the former picture was practically complete in itself, this one adds an ending which is not really necessary, but forms another complete story.

The picture deals with a group of international spies, who have perfected a wireless bomb which they desire to sell to some foreign ambassadors in the United States. Grimm, of the Secret Service, is put upon the case to prevent the deal from going through, and after a number of exciting experiences he is successful.

The leads are played by Alec B. Francis, Belle Adair and Edward Roseman, who have also appeared in the former picture. In the finale of this after the pretty international spy's two brothers have met with death in testing the bomb, she is taken under the protection of Grimm, and the supposition is that they are married.

"HUMAN HEARTS"

(Imp-Universal—Three Reels)

REVIEWED BY PETER MILNE

IF anyone is so far mistaken as to think that the real honest-to-goodness melodrama has passed out of existence, let that person see this picture. Whether it will please him or not depends on his individual tastes, but if he is looking for melodrama, and melodrama of the super-melodramatic sort, he will go into ecstasies over "Human Hearts." In that class of pictures this one is truly of the best.

It will be remembered that "Human Hearts" was once and perhaps still is a stage attraction. On the film it loses none of its force, and will form ample entertainment for the melodramatic-loving soul. To George Lessey goes the credit of having transposed the stage production to the motion picture. He has fully



THE ADVENTRESS ENTERS AND TROUBLE STARTS.

demonstrated his ability in a production of this variety, as will be verified when it has been seen by the public.

To begin with, we have the absolutely merciless, cold and immovable villainess; not even a prayer-meeting, nor the entreaties and beseechings of an old lady will melt her steely heart. Characteristic of all "villainesses," she begs the hero's forgiveness in the end, but he refuses, and she meets death by interfering with a misdirected shot from the villain's gun.

The villain is a bad individual also; his worst act is to stab the hero's father in the back, mistaking him for his offspring. Then the adventress steps in and accuses the son of the vile deed, and he is sent to the state prison. The poor boy's mother weeps bitterly and in weeping becomes blind, but it is she who secures the governor's pardon, which—although the villain has been chased from cover by a tramp who saw the deed committed, and convicted—will be liable to cause tears to come to the eyes of the soft-hearted.

The picture is constructed well and played in a corresponding manner, with King Baggot and Arline Pretty in the roles of the hero and heroine. The entire three reels are absorbing, the action is fast, and the scenes, especially those of the prison grounds, most realistic. Altogether, "Human Hearts" is an excellent melodrama.

"THE BEST MAN"

(Edison—Two Reels)

REVIEWED BY CLIFFORD H. PANGBURN

THIS film is an adaptation of a detective story of such an unusual and absorbing kind that it could hardly fail to be interesting. As a matter of fact the producers have taken full advantage of the novel to make a film which holds the attention from the first.

The production's only fault is one of the rarest known in the



THE UNKNOWN BRIDE

making of motion pictures, namely, it is too short. The book from which the picture is taken is so crowded with exciting incidents and situations that a four reel picture could have been made form it without the slightest padding, had the original been followed closely. It is regrettable that this was not done, for it is seldom a film can be criticised for being too short.

However, as may be imagined, the two reels are full of the fastest sort of action. "The Best Man" differs from most detective stories in that there are few, if any, scenes of actual violence. Instead, there are many startling situations and a surprising romance. Gertrude McCoy makes a charming heroine, while Marc MacDermott is seen in a dual role as the villainous would-be bridegroom, and the detective who found himself so unexpectedly married.

The detective goes to New York to get a copy of an important government cipher message from a band of wealthy crooks. He is introduced at a dinner as an expert on code translating. His task is to steal the cipher and return it to Washington. At great risk he manages to obtain the paper by means of a clever ruse, but is not out of the house before he is pursued. He leaps into a carriage, and is amazed to be driven to a church.

A wedding is about to take place, and the detective is seized and rushed into the church. He thinks he is the best man, or rather has been mistaken for him, and it is not until the ceremony is nearly over that he realizes he is being married to the pretty girl at his side.

He sticks to his place, however, as the crooks are waiting outside. How the bride was so ignorant of her fiance's appearance as to be deceived by a stranger and the ultimate success of the detective, and his wooing of his wife makes the rest a story of decided excellence.

CURFEW IN FORCE IN LOUISVILLE

Special to MOTION PICTURE NEWS

Louisville, Ky., Nov. 25.

THE old curfew ordinance forbidding children to be on the streets after 8 o'clock at night without the consent of their parents, has been revived at Lexington, Ky. Mayor Cassidy has instructed the Commissioner of Public Safety to write to the proprietors of theatres and picture houses requesting them not to permit children under fifteen years of age to enter these places of amusement after 8 o'clock.

"WHEN FATE LEADS TRUMP"

(Excelsior-Alliance—Four Reels)

REVIEWED BY H. S. FULD

THIS production from the book of Alice M. Roberts dealing with a story of a woman's trust, suffering unwitting error, and final happiness must interest all beholding it.

There is not a dull moment thought the entire four parts; the photography is exceptionally clear and distinct. The exteriors, the views of the mountain streams, the lumber camp scenes in the woods, are all fine, and examples of care in the choosing. The interiors are good in the main, only the cave scenes being a little crude. But the story is so interesting that this minor fault is lost sight of.

Gordon, against the wishes of his father, the leader of a band of smugglers, marries Marion Williams (Octavia Handworth), and taking his wife with him to visit his father is just in time to be caught in a raid of the police. He is captured with his father and the rest of the band, but Marion escapes.

After wandering around all night she is found by two lumbermen, and carried by one of them, Jim, to his home. Her privations, suffered in her all-night trip, have unbalanced her mind and she loses all recollection of her life previous to her rescue. Upon her recovery she consents to marry Jim and for a few years they are happy.

One day, Jim, who is now paymaster, comes home and finds Gordon, who has served his time and been released from prison, in the house with Marion. Gordon, not to compromise her remains silent when Jim gives him "one hour to explain or fight." Having first removed the bullets from his own revolver Gordon receives a mortal wound in the duel that follows, and dying, confesses to Jim that she married him years ago and believed him dead.

The acting of the entire cast is beyond criticism, although the fervor and realism of Marion's acting as interpreted by Octavia Handworth deserves special mention. Especially so in her escape from the cave when she climbs the cliff and her subsequent aimless wanderings where she is not averse to falling in the water a few times and getting thoroughly soaked.

Taken all together this production will prove an acceptable release and should add to the producer's reputation.

RESCIND LICENSE TO ENCOURAGE THEATRE OPENING*Special to* MOTION PICTURE NEWS

Buffalo, N. Y., Nov. 25.

IN an effort to have a motion picture theatre open in Falconer, N. Y., near this city, this winter, the village board has just passed a resolution abolishing a license fee for such theatres. In 1911 the same board passed a resolution charging \$500 license for picture shows.

The next year it was reduced to \$50, and in 1913 the fee was brought down to \$25. Each year the theatre in town has had several different proprietors, and each season it has closed down in the middle of the winter. It has been suggested that next year the village board give a bonus to anyone with nerve enough to start the enterprise.

DRAMATIC MOMENTS IN THE EXCELSIOR-ALLIANCE FEATURE, "WHEN FATE LEADS TRUMP"**"THE LAST DANCE"**

(Picture Playhouse—Five Reels)

REVIEWED BY CLIFFORD H. FANGBURN

ONE of the most difficult tasks which ever confronts a motion picture producer is to put on the screen a story of a heavily emotional type. With a company composed of American players such a picture usually falls flat because of the coldness and lack of sympathy of the acting, or else by reason of an unsuccessful imitation of the methods of some famous emotional artist.

If a European company attempts such a picture, and they do so with great frequency, there is an almost inevitable tendency to overact to such an extent as to appear ridiculous to American audiences. "The Last Dance" is acted by a Spanish company, but the last mentioned fault has been avoided, without falling into the first. True, there are a few spots where there is a considerable amount of heaving of bosoms and working of faces, but they are excusable because for the most part the acting is restrained enough to satisfy an American audience, but sufficiently gesticulatory to express the emotions of the characters.

In the matter of settings this picture is also noteworthy. A number of scenes take place in an opera house. For these is used a great auditorium with three tiers of boxes extending around the pit. The seats and boxes are filled with people in fashionable attire. As views from the front, back of the house and the boxes are shown the effect is most excellent.

Another excellent feature of the settings is the extensive use made of glass doors and partitions. These give the scenes a sense of richness, as well as presenting attractive vistas and offering opportunities for some very fine light effects.

The art gallery in which one scene takes place has every appearance of being the real thing. Speaking of art, the producers deserve a compliment on the costume of the hero, who is an artist. A simple, flowing black necktie is the only thing about his costume which differs from the ordinary civilian outfit. After the outlandish rigs which some American directors have used for artists recently this is a pleasant relief.

There are many other fine interiors, and in addition to this the scenes which take place out of doors are enacted before unusually pleasing backgrounds.

The cast is headed by Signorita Conchita Ledesma, a Spanish dancer widely known in southern Europe. Gustavo Serena is seen as her lover. Ninon, the model, is played by Laura Darville, and the part of the artist's friend by Camillo Tovagliari.

A poor artist is attracted by a famous dancer and forgets his faithful model. She induces the dancer to pose for the man she loves, although she realizes that she will probably lose him. She is right and the dancer and painter marry after the latter has won fame through his picture of the woman.

Later they separate to give themselves to their respective arts. The painter loses his money and is dying. His model, still faithful, goes for the dancer. Too late she realizes the folly of their separation. She dances for the last time for her lover, who dies before her. Feeling that life is no longer worth while she kills herself.

**"MY WIFE COMES FIRST!"****"BOYS, SHE'LL MARRY ME!"****HER MIND A BLANK**

"THE COLONEL OF THE RED HUZZARS"

(Edison—Three Reels)

REVIEWED BY CLIFFORD H. PANGBURN

THIS picture is a dramatization of the novel of the same name by John Scott Reed. The book belongs to the school of modern fiction which was made famous by Anthony Hope. It is the type of story which deals with the adventures of an American in some imaginary kingdom of Europe. Usually the American finds himself mixed up with the ruling family, and this instance is no exception. Nevertheless, it is a romance which is full of interest.

The film is marked by a series of effective settings, noticeable among them being those in the grounds about the royal palace. The photography is also of a high order. The cast is a strong one, excellent acting being the rule. Especially good work is done by Robert Conness, Marc MacDermott and Miriam Nesbitt.

Armand Dalberg, a young official in the State Department at Washington, meets the pretty young wife of an aged army officer.



"HERE'S A HEALTH TO THE QUEEN!"

He does not realize her true character until just before leaving to begin his duties as military attache at an American embassy in a small European kingdom.

It happens that the woman's husband dies on the day that Armand is leaving Washington. He calls to say good-bye and express his sympathy. The woman practically throws herself into his arms in the very next room to the one where her husband is lying in his deathbed. This so offends the young attache that he repulses the widow and hastens away.

Dalberg is a lineal descendant of a member of the royal family in the kingdom to which he is going. His noble ancestor had been exiled a century before as a result of a disagreement with the king. The present king, however, thought little of this and soon became so attached to his American cousin that he made him a Grand Duke, and induced him to renounce his American citizenship.

This Dalberg did only at the request of the Princess Dehra, with whom he was in love. Another member of the royal family, fearing that his title to the throne was being endangered by the American and also being jealous of his favor with the Princess, sent for the adventuress who had been spurned by Dalberg in Washington.

She appeared with a forged certificate of marriage and hailed Dalberg as her husband at a garden party. This nearly resulted in the young man's immediate banishment, but with the help of the American ambassador he finally proved the woman an impostor, and once more found favor with the princess and her father.

"CALLED BACK"

(Gold Seal—Universal—Four Reels)

REVIEWED BY CLIFFORD H. PANGBURN

HUGH CONWAY'S novel of the same name forms the basis for this drama. Although the original book purported to point a normal lesson in the matter of the way that workers

for some supposedly worthy cause may harm others its real interest lay in the fact that it presented a good story.

It is for this reason that the book was so widely read, both in this country and England. It is the type of story which is well suited for transfer to the screen, and Otis Turner, who directed the work, has been successful in his task.

The cast includes a list of favorites from Universal companies. Anna Little is seen as the girl who loses her memory but is later "called back." She handles the difficult part without overacting and with a decided charm. Her husband is portrayed by Herbert Rawlinson.

The action of the story takes place in England and on the Continent. As the picture was produced in California Mr. Turner had no easy time in obtaining the right atmosphere. The difficult scenes at the Siberian convict camp are specially well done, and the artificial blizzard is so realistic as to make the spectator shiver. By using modern costumes instead of those of the period in which the story is laid the producer has lost a chance to give the film an added touch, but he avoids the many difficulties surrounding a costume piece.

The story concerns a girl who loses her memory at the shock of seeing her brother killed before her eyes by one of a band of anarchists of whom her uncle is a leader. A blind man is present, but is allowed to go on account of his condition, which leads the murderer to believe that he can never give testimony. Two years later the blind man has been cured.

He has so altered his appearance that he is not recognized when he again encounters the anarchists. He finally marries the girl, and then discovers her condition. He sets himself the task of curing her by finding out the past events of her life. He succeeds in restoring his wife's memory after many adventures, which, among other things, lead to the death of the murderer at the hand of one of the band he has betrayed. There are a number of exciting incidents which cannot be described in so condensed an account of the plot.

"FOUNDLINGS OF FATHER TIME"

(Nestor-Universal—Two Reels)

REVIEWED BY PETER MILNE

A LINE on the first title of this picture remarks that it is "Respectfully submitted to those who have plenty to seek out and render aid to the aged poor," and no better sentiment could be prefixed it, as it makes a great human appeal to those of that class.

Productions that Charles Gyblin, the director, and Murdock MacQuarrie, leading man, turn their hands to, are practically sure to be good, and this is almost the best picture that they have turned out for some time. As a character study it has no superiors and very few equals. Containing little action it relies solely on its sympathetic trend, and the ability of the principals, Mr. MacQuarrie and Mrs. Benson to carry it through, which they do in an excellent manner.

Little else can be said of it, except book it, and it will most surely please any house. The story starts with the scene of an old firm. An aged bookkeeper is its most trusted employe, but a corporation being formed the old man loses his position, and thereafter can get no other, because of his age. Through all his misfortunes his wife remains loyal. They are turned out of their home, and finally out of their wretched room, where they meet death in the terrific rain storm that rages.

PREPARE FOR PHOTOPLAYERS' BALL

Special to MOTION PICTURE NEWS

Los Angeles, Nov. 23.

WHEN the auditing committee of the Photoplayers, Inc., the West Coast organization of actors, directors and others connected with the industry here read its report at the last meeting of the club following the weekly goodfellowship dinner, and it was found the indebtedness over and above all money on hand was about \$1,200, Manager I. Bernstein, of the Universal studios, made the motion that bonds of \$20, \$30, \$40 and \$50 be issued. Within five minutes more than \$1,800 had been subscribed by the players. The membership numbers about five hundred.

At this meeting the first steps in preparing for the second annual photoplayers' ball, at the Shrine auditorium on February 14, were taken when a committee on arrangements, consisting of Isadore Bernstein, Theodore Roberts, Charles Fais and George Melford, was named.

"UNREST"

(Selig—Two Reels)

REVIEWED BY T. S. MEAD

A TWO-REEL picture so thoroughly and uniformly good that it requires no special feature or over-worked thrill to excuse the second reel, and it will certainly be appreciated by every audience. Such a picture is "Unrest," a truthfully called psychological drama. By this be it not understood that the production is devoid of thrilling scenes. An exciting automobile race between Thomas Santschi as Tom Dean and Bessie Eyton as Bessie Garwood, a realistic bar-room fight, Tom's rescue of Bessie from her pretended drowning, would help a lot towards putting any picture over. But here these scenes merely add spice to a consistently good production, and are not used as the high seasoning necessary to make a poor one palatable.

W. E. Wing has hit upon an original idea for the plot of the scenario. Such originality would excuse a multitude of sins, were it necessary. In this case it is not, for the main idea is well supported by a perfectly logical development of the story.

The motherless Tom Dean is the cause of great anxiety to his father. For some unaccountable reason, Tom prefers the company of bar-room rowdies to the refinement and luxury of his own home. He fights for the seemingly uncontrollable love of fighting, and though not morally bad himself, he continually associates with a bad crowd of toughs. These tendencies worry Tom also, but he seems unable to combat them.

Professor Delmar, a loyal friend of Tom's father, becomes interested in this peculiar case, and thinks he finds its solution in the hereditary phenomenon of atavism; that Tom, in other words, has inherited the characteristics of his ancestors generations back, when brawn and muscle ruled, instead of brains. Professor Delmar persuades Bessie Garwood, an attractive society girl, to aid him in the treatment of Tom. Bessie starts in by one day soundly beating Tom in an automobile race, and taunts him with the fact that he has been outdone by a girl.

This, of course, gives Tom's vanity a great shock, but at the same time it arouses his first interest in one of the gentler sex. Shortly after this good beginning, he gets into another scrape, and thoroughly disgusted with himself he leaves home, this time going to the seashore, where he engages as a boatman. Here, Bessie finds him and renews the treatment in a clever manner. Success rewards her. Tom is not only cured, but love develops between them, and a few days later Tom writes his delighted father that he has been cured not by any involved psychological treatment, but simply by love.

"THE TWO COLUMBINES"

(Cosmofotofilm—Two Reels)

REVIEWED BY CLIFFORD H. PANGBURN

THE Christmas spirit stands out in this attractive picture in a most effective manner. There are many touches of pathos, and towards the end a tragic incident, but the outcome of it all is happiness for two young people, and a promise of a bright future for a little girl who had known nothing but the most abject poverty.

The stage scenes are well handled as well as those showing dressing rooms and other parts of the theatre, such as the switchboard. Even the cheerless appearance of the stage entrance on a winter night is depicted with accuracy and realism.

A poor woman who is barely keeping herself and her little girl alive by working as cleaner in a theatre arranges a pitiful little Christmas tree in a broken flower pot for the benefit of the child. Then the woman's past is shown. She had once been a beautiful dancer, and was the toast of the town. As Columbine in the Christmas pantomime she had reached the height of her popularity. In the middle of the gayety she made a false step and fractured her ankle. Her dancing career was thus ended forever, and left without any occupation she soon found herself reduced to the position of a cleaner in a theatre.

Leaving her little girl in bed the former Columbine goes to the theatre. It is Christmas Eve and a final rehearsal of the Christmas pantomime is being held. Columbine and Harlequin are sweethearts, but during the evening they quarrel. After everyone but them had left the theatre the cleaner brought her little girl to the place, and put her in a chair on the stage. Then she donned the costume of Columbine and tried to dance. Her lameness hampers her, but the little girl is delighted.

Overcome by the unusual exertion and her own weakness she faints, and is discovered by Harlequin as he is leaving the theatre. He calls for help and Columbine comes in, followed by the stage door-keeper and a policeman. It develops that the unfortunate cleaner is dead. Brought together by the incident Harlequin and Columbine forget their quarrel, and further decide to adopt the motherless little girl, and give her a good home. A simple story, but one which should please any audience.

"MORE THAN QUEEN"

(Pathe—Four Reels)

REVIEWED BY CLIFFORD H. PANGBURN

AN idea of the countless magnificent effects which will be seen when color photography is perfected can be obtained from this beautiful picture. The entire four reels are colored by the Pathe hand coloring process, and the work has been done with such consummate skill that it appears to be a natural color film. All things considered, this is one of the most beautiful pictures which has been shown in this country for many months.

Not satisfied with the color effects the producers have crowded the film with remarkable photographic feats, and scenes which are really extraordinary. Examples of the latter are most common in the parts which take place in and about the palace of the Queen of Norovia.

The Queen's drawing room opens by a great bay window on a long straight avenue of Lombardy poplars. Up and down this avenue gaily uniformed officers and stylishly dressed civilians can be seen riding horseback. The realism of the picture is brought out by another scene showing the same avenue some months later.

The leaves are nearly all off the trees showing that the view was actually taken some time after the first one. This may be only a detail but it is significant of the thorough excellence of the picture.

The most remarkable scenes are those showing the burning



THE BURNING OF THE PALACE

palace. Instead of the one small set as is usual for such a picture, a large number of interior and exterior views of the burning building are shown. The start of the fire and the attempt of the servants to extinguish it is also depicted with the greatest realism.

In fact the photographic quality of the film is so high that it is impossible to praise it too strongly. The acting is also a strong feature. The cast is headed by Mlle. Gabrielle Robinne, of the Comedie Francaise and M. Rene Alexander of the same theatre. They are supported by a capable cast.

The story is the weakest point, but it is one which holds the interest, and its only fault is that it is rather conventional. It tells of the widowed queen of Norovia, and her love for a lieutenant in the army.

A duchess causes the queen to lose faith in her humble lover, and later the unhappy woman loses her little son. She then abdicates the throne, and learning of the undying faithfulness of the man she had thought untrue finds happiness with him, and starts life anew.

Picker and Bennett Plan Theatre String

Latter Buys Half Interest in Burland and Eighth Avenue Houses—New Firm Expects to Have Broadway Location Soon

DAVID V. PICKER and H. Whitman Bennett announce that they have joined forces for the purpose of founding an extended circuit of large theatres. The alliance has been brought about through the sale by Mr. Picker to Mr. Bennett of a half interest in the control of the Burland and Eighth Avenue theatres.

Mr. Picker, who has long been widely known in mercantile circles, assumed the lease of the Burland theatre at 985 Prospect avenue, Bronx, even before the erection of the house and was indeed responsible for the building of a theatre of such unusual proportions.

He assumed direct personal management in June of the current year, and since that time the Burland has become the admitted center of Bronx motion picture events. The Burland is an absolutely modern fireproof building and has the largest seating capacity of any playhouse in the Bronx, in addition to an immense "open air" for warm weather use. It was here "Cabiria" was recently presented for a number of consecutive days to record-

breaking business for uptown New York.

The Eighth Avenue theatre was formerly known as Miner's Eighth Avenue. As in the case of the Burland, this house is now devoted to the very best motion pictures obtainable. It has recently been remodelled and all obstructions removed from the auditorium.

Though a positive announcement would be premature at the present moment, Picker and Bennett expect soon to have a theatre on Broadway, where they will establish central offices for the circuit, which is also to include houses in Brooklyn and nearby cities. Mr. Picker will remain in personal executive charge of the joint enterprises on behalf of himself and Mr. Bennett.

Mr. Bennett is well known as a newspaper man and press agent, and was for several seasons the general press representative of the Shuberts. He severed his last previous connection with the Mutual Film Corporation to become press representative for the Jesse Lasky Feature Play Company and to enter into his new affiliation with Mr. Picker.

Additions to Edison Studio Now Finished

Four-Story Concrete Structure Replaces Old Frame Building Destroyed by Fire—New Offices and Dressing Rooms in New Edifice

THE alterations and additions to the Edison Studio in the Bronx, New York City, made necessary by the fire of a few months ago, are now completed and in use by the company.

The large stage floor and the massive glass dome which the flames destroyed, have been replaced, while the work of production was carried on without interruption. On the site where the frame building, which consisted of directors' offices and projecting room, once stood, has been erected a new four-story concrete structure to be used especially as dressing rooms for the "extras."

On the second floor is the costume department, where every conceivable costume from that of messenger boy to king may be had. There is a private entrance for

the extras, direct from the street to the dressing rooms, thus eliminating the necessity of their passing through the studio proper and interfering with the regular routine. On the ground floor is the kitchen, presided over by a chef, who supplies luncheon to all desirous of remaining in the studio during the noon hour.

Aside from the dressing rooms in the main building, four large and completely appointed dressing rooms are for use by the regular staff artists. A section of this new structure consists of a suite of ten offices for the sole use of directors and stage managers.

These much-needed changes will greatly improve conditions for all concerned, and will greatly facilitate the making of new pictures.

Blaisdell Joins Mica Film Corporation

Former Treasurer of Centaur Company, Who Knows the Film Industry in Its Various Branches, Will Assume Duties of General Manager

ROLAND BLAISDELL has joined the forces of the Mica Film Corporation, issuing the "Kriterion Program." Mr. Blaisdell, while well known in film circles, is one of the young "old timers" of the business. His experience covers practically every branch of film industry from the studio to the exchange.

He was for several years assistant cashier in one of the largest banking institutions in the city. Leaving this position, broken down from several years of overwork, he became a salesman for several lines in New York and vicinity, but finally decided that the film business presented the

best opportunity in the country. He entered one of the General Film exchanges, but in less than two months he received another offer and accepted. Later he was general-manager of the American Lumiere Film Agency for over a year, and treasurer of the Centaur Film Company, of Bayonne, a year.

His film experience, therefore, covers nearly the entire field from raw stock, laboratory, studies and exchanges to features. In his new position he will be secretary to the general-manager, and will be practically assistant general manager of the company.

AUGUST AND TERRISS JOIN KINETOPHOTE

Edwin August and Tom Terriss have joined forces with the Kinetophote. They have already begun to cast for the first of a series of photoplays taken from famous plays and books which each will produce and appear in for the Kinetophote.



EDWIN AUGUST

Edward Mackay, who has been directing for the Kinetophote, will remain with the company and continue as director and star in other features which will be produced by the corporation.

The arrangements between Mr. Terriss and Mr. August and the Kinetophote were made complete this week and each of these sterling screen players has established himself in the offices of the corporation, at 126-132 West 46th street.

Mr. August has arranged to take up at once work on one of two popular novels the rights of which have been bought by the Kinetophote. Mr. August will work with the author of the one selected as the first feature which he will produce, and will closely follow the original ideas regarding the characters. Each member of the cast will, therefore, be carefully selected as to looks and ability for the particular role which he is to play.

Mr. Terriss will produce and star in the famous Terriss plays made noteworthy not only by his father, the great English actor, but by himself as well.

The rise which Edwin August has had in pictures has been steady from the time when he played leads with Mary Pickford and Blanche Sweet in the old Biograph days. In addition to writing and producing, Mr. August has been the star in many of the screen dramas which have been made by him.

BEVERLY BAYNE ALMOST BITTEN BY COPPERHEAD

Beverly Bayne narrowly escaped death when attacked by a deadly copperhead snake while taking a scene for the Essanay production, "Every Inch a King," in the woods near Niles Centre, Ill.

INTERESTING FILM REVIEWS

PRODUCTIONS FROM ALL PROGRAMS

GENERAL FILM PROGRAM

"The Means and the End." (Essanay. Two reels. Fri., Nov. 20.)—This is a strong drama of the struggle between capital and labor, in which a sociological worker, by a threat to expose an old crime, forces a capitalist into erecting a model tenement house. The sociological worker falls in love with the capitalist's daughter, and comes to the conclusion that he is not justified in forcing money from Hildebrand, even for a good cause. The daughter has, in the meanwhile, fallen in love with him. Everything clears up and ends happily. The picture contains a very thrilling scene of a fight in a darkened room and it is well acted by Rapley Holmes, Gerta Holmes and Richard C. Travers.

"All on Account of the Cheese." (Biograph. Mon., Nov. 23.)—An amusing comedy founded on the familiar situation of a woman who mistakes the noise made by some mice for evidence of burglars in the house. Madge Kirby, Clarence Barr and Dave Morris are in the cast. On the same reel with "Thrown Off the Throne."

"Thrown Off the Throne." (Biograph. Mon., Nov. 23.)—A burlesque involving a mixture of kings, queens and delicatessen. In the cast are Clarence Barr, Gus Pixley, Florence Lee and Dave Morris. On the same reel with "All on Account of the Cheese."

"The Romance of a Poor Young Man." (Biograph. Two reels. Tues., Nov. 24.)—This is a screen adaptation of the widely read novel of the same name by Octave Feuillet. The story of the adventures of the poor young man in the course of his attempt to regain his property and win the girl whose father had stolen it is one which is full of interest. There is a strong cast headed by Edward Cecil, Gretchen Hartman and Marie Newton.

"The Way Back." (Biograph. Wed., Nov. 25.)—A clergyman saves a girl who is in a bad way, and brings about her happy marriage to a friend. Later he leaves the ministry to become a novelist. He meets success but takes to drinking. When he has sunk to a very low condition he is rescued by the girl he had saved from the same life. In the cast are Alfred Paget, Hector Sarno and Vivian Prescott.

"His Old Pal's Sacrifice." (Biograph. Fri., Nov. 27.)—A crook saves his pal's life in a fire, and is badly hurt. At the hospital he falls in love with his nurse, reforms and marries her. All is well for a time until a great temptation to make money causes him to fall back into evil ways. Then the man whose life he has saved has a chance to save his friend's happiness, and does so. In the cast are Charles West, William Hartman, Frank Evans and Claire McDowell.

"Little Miss Make-Believe." (Biograph. Sat., Nov. 28.)—A princess telegraphs at the last minute that she cannot attend a reception to be given in her honor. They get a governess to take her part as they are set on having the reception go off as planned. A wealthy young bachelor falls in love with her, and to the surprise and dismay of the other girls marries her, when he learns to his relief that she is not a real princess. Irene Howley and Jack Mulhall head the cast.

"Fate's Tangled Threads." (Lubin. Mon., Nov. 30.)—The twelfth of the "Beloved Adventurer" series. In the last installment Betty has been deceived into leaving her loving husband under the belief that he no longer cares for her. Her husband has searched for her in vain. He goes to the aid of a farmer's daughter on his estate, who has been abducted by a man from the city. He saves the girl, and in doing so happens upon the lost Betty. She is just leaving a pier in a motor boat with her crooked guardian and before he can get another craft she has disappeared into the darkness. Lottie Briscoe and Arthur Johnson, with the usual cast, are seen.

"Everything Against Him." (Vitagraph. Mon., Nov. 30.)—Circumstantial evidence results in the arrest of an innocent man for the killing of a friend who is actually alive and well. The return of the supposed dead man results in the other's release. A story with little action.

"A Maid of War." (Essanay. Mon., Nov. 30.)—Two hoboes play havoc with Sweedie's dramshop while Sweedie is explaining the European war situation to her friends, the donkey and the rooster. A chase through the rigging of a vessel, an interrupted marriage ceremony and a fight in the saloon flooded by the contents of an opened keg follow.

"Her Bitter Lesson." (Kalem. Two reels. Mon., Nov. 30.)—A story centering about a wife whose selfishness is so great that she uses every cent of her husband's money that she can get for useless things. The husband is putting across a big deal and needs every dollar. He borrows \$1,000 and puts it in the safe at home. This is to be used as a last resort. When the husband goes for it he discovers that his wife has used it. He puts the deal across successfully, but resolves to teach his wife a lesson. He tells her that they are practically bankrupt, and moves to a cheap apartment, where she has to do her own housework. Finally she learns her lesson, and they go home in happiness. The situation is complicated by another man who vainly seeks to induce the wife to leave her husband. In the cast are Harry Millarde, Alice Hollister, Robert Walker and Helen Lindroth. Emotional but well acted.

"Wood B. Wedd Goes Snipe Hunting." (Edison. Mon., Nov. 30.)—Reviewed in MOTION PICTURE NEWS, issue of Nov. 14, page 47.

"Temple of Moloch." (Edison. Wed., Nov. 25.)—Reviewed in MOTION PICTURE NEWS, issue of Nov. 14, page 47.

"Last of the Hargraves." (Edison. Sat., Nov. 28.)—Reviewed in MOTION PICTURE NEWS, issue of Nov. 14, page 47.

"His Chorus Girl Wife." (Edison. Mon., Nov. 23.)—Reviewed in MOTION PICTURE NEWS, issue of Nov. 14, page 47.

"A Gypsy Madcap." (Edison. Tues., Nov. 24.)—Reviewed in MOTION PICTURE NEWS, issue of Nov. 14, page 47.

"Coupon Collectors." (Lubin. Tues., Dec. 1.)—A burlesque of the coupon and trading stamp fiends. A burglar steals a great collection of coupons only to have them taken by a policeman. On the same reel with "For a Widow's Love."

"For a Widow's Love." (Lubin. Tues., Dec. 1.)—The doctor and the judge are rivals for the widow. They fight a duel with blank cartridges, and have other exciting adventures. The doctor finally wins the widow. An amusing burlesque. On the same reel with "Coupon Collectors."

"Saved from a Life of Crime." (Vitagraph. Two reels. Tues., Dec. 1.)—A small boy of the streets is guilty of a highway robbery at the age of twelve. Fortunately he is arrested and put under the care of a wise probation officer who sees his inherent good qualities. This officer suggests the boy to a wealthy man who is seeking someone to adopt. The rich man adopts the boy, who becomes a fine young lawyer. He falls in love with his benefactor's daughter, but has no intention of proposing because of his lowly birth. A fire at which the young lawyer proves himself a hero leads to his marriage with the girl and proves the cowardice of a wealthy suitor.

"Bill, Bud and the Waiter." (Kalem. Tues., Dec. 1.)—A burlesque comedy featuring Ruth Roland, Marshal Neilan, Lloyd Hamilton and Bud Duncan in a series of amusing situations. Bill cuts out his young brother, but comes to grief owing to a too frequent use of the system of putting a fly into the ice cream and then refusing to pay for his meal. Confronted by six former sweethearts and an angry restaurant manager Bill leaves hurriedly and Bud is happy.

"The Buffer." (Essanay. Tues., Dec. 1.)—A high finance drama in which a youngster of six prevents his father from sacrificing an older son in order to reap vengeance upon a rival magnate. Rapley Holmes, Richard C. Travers and Master Rockwell are the cast.

"The Rival Stage Line." (Selig. Tues., Dec. 1.)—A Western comedy with sufficient plot to enable Tom Mix to put across an exciting break-neck race between two stage coaches. The prize is an express contract and the heart of a girl hoth stage owners love. Each stage coach breaks down, and the two rivals lose the contract and the girl, but the misfortune turns them from bitter enemies into close friends.

"The Fable of the Club Girls and the Four-Times Veteran." (Essanay. Wed., Dec. 2.)—Another of George Ade's clever comedies. A stern faced widow, veteran of four trips to the altar, hears the amateur wives discuss the greatest current evil, "Man." Then she proceeds to tell them a thing or two which they have not learned on the subject of husbands. Her most popular one of the four was a railroad man who was never home. Moral: Absence makes the heart grow accustomed.

"The Lion Hunter." (Selig. Wed., Dec. 2.)—A realistic and well produced South African drama featuring the animals of the Selig jungle-zoo. A young Boer, enraged because his sweetheart's love has been stolen from him by an Englishman in a party of lion hunters, engages a tribe of hostile blacks to make way with the hunting party. His sweetheart, in endeavoring to frustrate the plot, is herself captured by the savage tribe, and rescued only after many privations. In the joy of her recovery all is forgotten and forgiven. This picture is made doubly interesting by the remarkable jungle scenes.

"The House of D'Or." (Lubin. Two reels. Wed., Dec. 2.)—The heir to a great estate is cleaned out of his fortune by the financial tricks of his father's chief rival. He sinks until he becomes almost a hobo. Twenty years later he is led by a series of incidents to brace up and make something of himself. He soon meets with such success that he breaks the man who broke him. In the cast are W. E. Parsons, George Routh, Velma Whitman, Melvin Mayo, L. C. Shumway and Rose Morris.

"The Prodigal." (Kalem. Two reels. Wed., Dec. 2.)—By a coincidence a country girl obtains work as a stenographer in the office of a man who had tried to force his acquaintance on her on a former occasion. Seriously in love with her, the man induces the girl to marry him, much to the disgust of an adventuress who had been victimizing him. She tries to separate the pair, and succeeds in forcing the young wife to go home. The husband realizes what a beast he has been and follows her. Making a firm resolution to reform permanently the husband comes to his wife as a penitent, and they find happiness together. In the cast are Tom Moore, Gertrude Barnes and Marguerite Courtot. A well acted and effective film.

"The Mysterious Mr. Davy." (Vitagraph. Wed., Dec. 2.)—Vanity leads a man who is happily married to carry on a flirtation with a woman. He tells his wife that his mysterious dinners are with a "Mr. Davy," and she believes him until he mixes notes. Even then he makes things all right by getting an obituary of Mr. Davy printed, and ending his flirtation.

"The Man That Might Have Been." (Vitagraph. Thurs., Dec. 3.)—The wife and baby son of a poor clerk die on the same day. The father becomes almost crazy, and during the years that follow imagines the things his son might have done, and sees them all accomplished by his employer's boy. When the young man has achieved great success the old clerk dies happily. A psychological study.

"Sophie's Fatal Wedding." (Essanay. Thurs., Dec. 3.)—Slippery Slim, a rejected suitor, prevents the wedding of Sophie and Mustang Pete by waylaying the minister and tacking a small-pox sign on the door of the justice of the peace. Sophie is naturally discouraged by Mustang Pete's inefficiency as a bridegroom, and receives Slippery Slim with open arms.

"The Time, the Place and the Man." (Essanay. Two reels. Thurs., Dec. 4.)—Another "Munsey Magazine" story which makes a most interesting picture drama. The feature scenes of this well produced picture are the fight in the darkened mine tunnel, and a panic at the stock exchange. The story, though rather involved, is made perfectly clear. A young civil engineer, whose life is plotted against by a rival railroad magnate, accidentally discovers a way to connect two competing lines and thereby bring financial ruin to its unscrupulous rival road. It is well acted by a cast including Richard Travers, Rapley Holmes and Gerda Holmes.

"A Believer in Dreams." (Lubin. Fri., Dec. 4.)—A girl becomes infatuated with a man largely as the result of a dream. Later the second

installment of what appears to be a serial dream comes along and warns her in time so that she jilts the man at the church. Ormi Hawley, Edward J. Pell and Richard Morris play the leads.

"Which Ham Is Schnappsmeier's?" (Selig. Fri., Dec. 4.)—A nonsensical comedy with many good laughs arising from the mistaken identity of two separate and distinct hams. On the same reel is "Love's Acid Test."

"Love's Acid Test." (Selig. Fri., Dec. 4.)—On the same reel with "Which Ham Is Schnappsmeier's?" Another really funny comedy. A lovesick drug clerk puts poison in a prescription, but after a wild chase succeeds in warning the unsuspecting patient before any harm has been done.

"The Devil and Mrs. Walker." (Kalem. Fri., Dec. 4.)—A slapstick comedy in which a henpecked husband becomes head of the family for about twenty-four hours as the result of wearing a devil's costume. When his wife discovers the trick his lot is worse than ever. In the cast are Carrie Ward, John Brennan, Ethel Teare, Frederick Hornby, Josephine Rice and Lee Hill.

"The Methods of Margaret." (Vitagraph. Fri., Dec. 4.)—The flirtatious stenographer employed by a young married man causes his wife some worry, but her husband refuses to dismiss her, saying that he lets his wife's household servants alone. When the wife dismisses her maid and hires a man as a secretary, and has only male servants her husband changes his mind. An entertaining comedy.

"Bunny's Little Brother." (Vitagraph. Two reels. Sat., Dec. 5.)—An amusing comedy depicting the woes of the ponderous Bunny when forced by his wife to take Dr. Shrinkum's treatment for reducing weight. Bunny's thin twin brother enters into the complications which follow and many ludicrous incidents result.

"The Stolen Engine." (Kalem. Sat., Dec. 5.)—Another of the "Hazards of Helen" series. Some thieves make off on a stolen locomotive with a valuable package. With another locomotive Helen goes in pursuit on a parallel track. Overtaking the flying engine the girl and her helpers jump from their's to it and capture the thieves. The picture is filled with the usual excellent railroad scenes, and the thrills are pronounced. Helen Holmes and the regular cast appear.

"Broncho Billy's Judgment." (Essanay, Sat., Dec. 5.)—Broncho Billy and his pal love the same girl, but she marries a good-for-nothing gambler. Years later Broncho Billy, now sheriff, is called upon to arrest a murderer in a neighboring town. He finds that this murderer is his old pal, who shot the brutal husband of the girl they both had loved. Broncho Billy takes off his star rather than arrest his old friend.

"Her Sister." (Selig. Sat., Dec. 5.)—A floor-walker in a large department store plays upon a girl employee's fear of his authority to compromise her. Her sister seeks to avenge the wrong, only to find that retribution had already come to him in the deadly sting of a wasp. Both girls marry their real lovers, and all is forgotten. A good treatment of a much used subject. The acting of Stella Razeto and Adda Gleason is excellent.

"It's a Bear." (Edison. Sat., Dec. 5.)—Tramps find a lost trunk containing an outfit for masquerading as a bear. They visit a summer hotel just in time to give a youth a chance to prove himself a hero. He is very reluctant to do so, and when the real nature of the bear finally comes out he is worse off than ever. A quiet, but entertaining comedy.

"He Wanted His Pants." (Lubin. Sat., Dec. 5.)—The familiar incident of a wife searching her husband's pockets is the basis of this comedy. The husband calls in the police and gets back the cash. On the same reel with "Brown's Cook."

"Brown's Cook." (Lubin. Sat., Dec. 5.)—An entertaining bit of slapstick concerning the servant problem as it confronted one man. On the same reel with "He Wanted His Pants."

UNIVERSAL PROGRAM

"For the People." (Victor. Fri., Nov. 20.)—Reviewed in MOTION PICTURE NEWS, issue Nov. 14, page 47.

"The Bachelor's Baby." (Rex. Sun., Nov. 22.)—Reviewed in MOTION PICTURE NEWS, issue of Nov. 14, page 47.

"Our Beloved Country" and "A Friend in Need." (Eclair. Split reel. Sun., Nov. 22.)—Reviewed in MOTION PICTURE NEWS, issue of Nov. 14, page 47.

"Sammy's Vacation." (Crystal. Tues., Nov. 24.)—What little comedy that appears in this reel could have been told in a very few feet. Some of the actions of the police force and their effeminate appearing captain might pass under the head of humor, but it is doubtful whether they will please the average person seeking for that variety of entertainment. The plot is so neglected that it counts for little.

"A Lonely Salvation." (Victor. Mon., Nov. 30.)—Mary Fuller, in the role of a thief, is led to reform through her captor (Charles Ogle). She is sent to work in the West, and after withstanding many temptations and becoming engaged to the man by letter, returns to surprise him, and finds that he has died. A pathetic offering, far out of the ordinary, and well acted.

"The Mystery of the Sea View Hotel." (Rex. Two reels. Thurs., Dec. 3.)—Ben Wilson directed and played the lead in this picture. He still retains his familiar role of detective and solves a mystery which is so deep that no one will have the faintest suspicion of the culprit. As a detective story this is one of the best.

"The Coward." (Imp. Two reels. Mon., Nov. 30.)—A distasteful subject, but played well by Dorothy Phillips and Edmund Mortimer, supported by Alexander Gaden and Howard Crampton. The man is a member of a regiment. His wife is addicted to the drink habit. When war occurs he remains at home and finally cures her. He is branded as a coward by his fellow members, but finally the truth is learned and all is well. Some of the scenes, especially those in which the wife is fighting against her craving for drink, could be shortened.

"Charlie Woos Vivian." (Crystal. Split reel. Tues., Dec. 1.)—On the same reel with "The Barber Shop Feud." Almost every picture arouses our expectations and after this one has done so it drops them with a thud. The ending here is abrupt and can well be called incomplete. Charlie volunteers to show his bashful clerk how to propose to the stenographer; she, much to his surprise, accepts him, and when he says it's all a joke, she sues for breach of promise, so Charlie resolves to be contented with her. Charlie DeForrest and Vivian Prescott are in the leading parts.

"A Barber Shop Feud." (Crystal. Split reel. Tues., Dec. 1.)—On the same reel with "Charlie Woos Vivian." This comedy is little better than its mate in regard to termination, but it contains a few rough comedy moments which will be appreciated by some few of motion picture goers. Two barbers are in love with the manicure girl, and after they have put themselves through a number of awkward antics for the amusement of the audience, one of them succeeds in squeezing "yes" from her.

"The Ghost of Smiling Jim." (101 Bison. Two reels. Thurs., Dec. 1.)—This produced great suspense and will therefore pass as an excellent melodrama. Francis Ford and Grace Cunard are the principals. The prospector is reported dead to his wife, and she dies from the shock. But the prospector is not dead; he loses his mind, and several years later he is found by his daughter. Seeing her restores his memory.

"The Wise Guy." (Joker. Wed., Dec. 2.)—Two gentlemen are rivals in love, one impersonated by Ernest Shields, is very absentminded; his actions are extremely funny. The husband of the girl shows up in the end.

"The Young Philanthropist." (Imp. Universal Boy, No. 11. Thurs., Dec. 3.)—A series of instructive scenes are shown here illustrating the manner in which milk is pasteurized. Matty appears in his usual role of comforter to the distressed and finally manages to turn the attentions of an agent to the welfare of his tenants.

"The Heart of a Magdalen." (Powers. Two reels. Fri., Dec. 4.)—A forcible story presented by De Grasse's company, headed by Edna Mason, Bert Hadley, Beatrice Van and Joe King. Through posing as a Madonna for an artist the aspect of the woman of the world is completely changed. She learns to love him, but he prefers his former love. This latter statement may be questioned, as the picture leaves the artist comforting his model.

"Father Buys a Bale of Cotton." (Victor. Fri., Dec. 4.)—A real laugh maker, produced by C. J. Williams, with Elsie McLeod in the leading feminine role. Elsie's sweetheart changes her father's order for one bale into one hundred, and the consequence is the old gentleman is swamped with it, but the citizens seeing his good and philanthropic ways, nominate him for mayor. The man who plays the part of the father is a real comedian; he has many chances to put in humorous touches and makes use of all of them.

"The Best Man." (Frontier. Sat., Dec. 5.)—This is a pleasant subject but handled none too well by the actors and director. A few good scenes have been caught by the camera, but the photography is below the average of the day. The Western man, believing his wife in love with another, leaves her, intending to take a fling at highway robbery, but he is prevented from so doing by seeing a vision of her. Later he is found and brought home by another man who loves his wife. Walter Rodgers is the husband, Lillian Christy his wife, and Jay Morely the other man.

"A Circle of Gold." (Frontier. Sat., Dec. 5.)—This is a fascinating and well developed story, which runs along very smoothly until a drunken hobo is lifted from the gutter and made the leading man of a motion picture producing company. This fact may cause the audience to smile, as such days are supposed to be over. However, it paves the way for the reunion between husband and wife, and opens their eyes to each other as they married when the man was under the influence of liquor. Fred Church and Edythe Sterling are the principals.

"A Dream of Painting." (Joker. Sat., Dec. 5.)—Mr. Peck dreams, and in his dream a painting of an Egyptian princess comes to life and persists in hugging him, to his great fear. Fairly funny. William Franey, Louise Fazenda and Gale Henry are the principals.

MUTUAL PROGRAM

"Old Enough to Be Her Grandpa." (American. Fri., Nov. 20.)—A very good comedy drama showing the way in which an elderly merchant cured his grandson of a passion for an actress. He makes love in a rather public manner to an attractive girl who is employed in the store. The grandson is given every encouragement in his match with the actress, but is so attracted by the girl his grandfather has picked out that he throws over the woman of the stage, and starts to cut out his grandfather. This is just what the old gentleman wanted, and he gives his blessing to the couple. Vivian Rich and William Garwood head the cast.

"His Responsibility." (Reliance. Two reels. Sat., Nov. 21.)—A forceful and gripping drama with an unusually effective plot. A girl, refusing to marry at her father's direction, elopes with a young broker. Three years later the husband finds himself on the verge of bankruptcy as the result of a theft by a trusted messenger. He contemplates suicide, but finds that in case of such a course his insurance will not be paid. He then hires a desperate crook to kill a man passing a certain corner at ten that night. He walks past, intending to die, but detectives who have followed the man prevent it. On going home he finds a letter which his wife had forgotten to give him. It is from the messenger, and states that he has made money and incloses the stolen funds with interest. Irene Hunt and Ralph Lewis head the cast.

"The Saving Grace." (Majestic. Two reels. Sun., Nov. 22.)—The wild young daughter of a drunkard in a Western town is induced to go to school by the minister. She grows much attached to him and on seeing him kiss a strange girl becomes so jealous that she gets her drunken father to promise help in getting revenge. Fortunately the minister's life is saved by the excessive drunkenness of the man. Then the girl learns that the minister had been kissing his sister. George Seigmann is particularly effective as the father. Fred Burns as the minister tends too much towards comedy, while Dorothy Gish is unconvincing. However, the picture is one which has considerable interest.

"Nature's Celebrities." (Thanouser. Split reel. Sun., Nov. 22.)—An educational subject, on the same reel with "A Messenger of Gladness," showing the peculiarities of the African chameleon and the Indian cobra. A very interesting half reel.

"Ethel Has a Steady." (Komic. Sun., Nov. 22.)—The eleventh of the Bill series featuring "Tammany Bill" Young and Fay Tincher. An entertaining comedy in which the stenographer and her employer both have trouble with their sweethearts as the result of a letter which Bill intended for a fair typist across the hall. Fay Tincher's costume is best described as a scream.

"Our Mutual Girl, No. 45." (Reliance. Mon., Nov. 23.)—Besides visiting a famous modiste's, and seeing a number of points of interest about New York, Margaret has the good fortune to reunite a man and his wife who have been separated for years. This she accomplishes by means of a strange feeling which makes her believe that an old clerk who faints while she is in the modiste's is the man for whom she is looking. This proves to be the case.

"A Messenger of Gladness." (Thanouser. Split reel. Sun., Nov. 22.)—This picture is bubbling over with the good spirit of Thanksgiving. Helen Badgely plays the good Samaritan in a number of instances when she reconciles a husband and wife, re-arranges an upset love affair, et cetera. It is a picture that will make everyone happy and is shown on the same reel with "Nature's Celebrities."

"Mrs. Van Ruyter's Stratagem." (Thanouser. Two reels. Tues., Nov. 24.)—Although we have seen the same idea that is the basis of this drama pictured before, it is so different from the general run of dramas that it has an air of originality. The rich widow is in a quandary as to which of her relatives shall receive her fortune. At the suggestion of her lawyer she changes places with her housekeeper and invites them all to stay at her home for some length of time. They are all imposing, haughty or artificially friendly, except one who happens to be serving the widow in the capacity of maid. She wins the fortune and also the young lawyer's heart. Carey L. Hastings is the widow, Muriel Ostriche the heiress and Harry Benham the lawyer.

"As a Man Thinketh." (Beauty. Tues., Nov. 24.)—A boss-ridden and henpecked clerk goes to a fortune teller, who says that he is a man of iron will intended to be a leader of men. He takes the words so seriously that it makes a man of him. In one day he makes a big sale, gets his salary almost doubled, and becomes boss of his home.

"The Archaeologist." (American. Wed., Nov. 25.)—A comedy in which two girls bury some antiques for the purpose of having some fun with an ardent but youthful archaeologist. The plan works so well that he is soon engaged to one of the girls. Many pretty scenes. The supposed scholarly attitude of the student is entirely overdone.

"They Never Knew." (Reliance. Wed., Nov. 25.)—Things happen and cease happening with remarkable suddenness in this picture, but for all that it will please everyone. Arthur Mackley directed the picture and has managed to get an unusual amount of action into the one reel, more than what often appears in two. The country girl, enamoured of a city salesman, consents to elope with him, forgetting the man she had promised her heart to. She leaves a note to her parents to the effect that she is going to marry the man she loves. Her true lover sees the city man tempting her with wine in a cafe, enters, beats him up and then marries the girl. R. A. Walsh is the hero and Vester Perry the heavy.

"A Bum Mistake." (Princess. Fri., Nov. 30.)—The old case of mistaken identity creates a great rumpus in this reel, and a few humorous moments appear. The horse, worked by two men on the inside of some queer skin, is perhaps the funniest point in the picture. A real tramp is mistaken for an actor tramp, and receives the dinner set for the other. Quite a bit of rough work appears toward the end of the reel, which is devoid of humor.

"A Romance of Old Holland." (Broncho. Two reels. Wed., Dec. 2.)—An excellently constructed offering, containing a story that is absorbing throughout. The Dutch atmosphere has been admirably obtained. The aged ship owner desires the hand of a girl many years his junior, and bribes the captain of one of his ships to do away with her lover while on a voyage. The young man is deserted and left in a small boat, but he reaches a derelict, steers it to port, and arrives just in time to prevent the old man from marrying the girl.

"The Vigil." (Domino. Two reels. Thurs., Dec. 3.)—A story laid in Japan, acted by the Japanese cast headed by Tsuri Aoki and Sessue Hayawaka. The plot is un-American until the end, when a touch of American melodrama creeps in. The interest is admirably sustained throughout both the reels, and the story, which deals with the attempted revenge of a disappointed suitor, is extremely well constructed. Some beautiful light effects have been obtained and the photography is excellent in all the scenes.

"Mother of the Shadows." (Kay-Bee. Two reels. Fri., Dec. 4.)—This is one of the best offerings that the Kay-Bee forces have offered us for some time. The story is so logically developed and contains such an appealing theme, that as a two-reeler this picture is of the best class. Tsuri Aoki has the pathetic part of an Indian girl, betrayed by a soldier, who finally sees the evil of his ways and marries her, more to prevent an uprising of the Indians than for love, however. Later the Indian girl's stratagem saves the fort from the hostile Indians, but she receives a very serious wound. After she has been attended to she realizes that her husband is ashamed of her and tears the bandages from her wound and bleeds to death. John Keller is the soldier. Realism predominates in the battle scenes, in fact through-

out the whole picture, but it is the sympathetic subject dealt with in such an appealing manner that will be responsible for its success.

WARNER'S FEATURES

"Slippery Sadie, the Diamond Biter." (Starlight. One reel.)—A burlesque on an old time melodrama. The girl crook robs divers persons of their diamonds using her teeth to good advantage. The wrong girl is accused and sent up for eighty years, but her lover rescues her.

"All at Sea." (Albuquerque. Split reel.)—On the same reel with "Rural Romeos." The girl elopes with the city chap in his motor boat. The minister and her father happen to be in the row boat trailing behind. They enjoy quite a wild and fearful ride before they are upset, rescued and consent to the marriage.

"Rural Romeos." (Albuquerque. Split reel.)—On the same reel with "All at Sea." Concerning the adventures of three of the gentlemen mentioned in the title at odds about a country girl. The huskiest one wins her after a number of laughs.

"Father—A Member of the Purity League." (Premier.)—Mother rules both her husband and daughter with an iron hand; she even attempts to make the former stay home while she holds a Purity meeting. This reel will furnish some amusement. The comedy is rather low, but funny, at times.

"Camille as She Never Was." (Superba.)—This makes a fair burlesque with Charlie De Forrest in the leading role; not the name part, however. The humor is rather crude, but some of it may strike people as funny.

"A Mender of Ways." (Premier.)—A pleasing drama in which a minister causes the reformation of an habitual inebriate, who is married to the preacher's former sweetheart. Walter Rodgers is the husband.

"Shot in the Fracas." (Luna.)—Two stalwart tramps drop off into a town, whose sheriff and deputy have just decided that all Knights of the Road shall be allotted thirty days. They are afraid of the hoboes, however, and a wild mixup ensues in which the tramps are triumphant.

"Stockings." (Starlight.)—A hod carrier dreams of becoming a renowned detective, but he makes blunders every way he turns in looking for a girl thief with striped stockings. He arrests several, and in attempting to arrest several more is soundly beaten up.

"The Love of Princess Yolande." (Warner's. Two reels.)—A pretty romance with Elsie Albert in the title role. The princess must marry the prince of a neighboring kingdom. For weeks before her wedding she masquerades as a shepherdess, and meets the prince who is assuming the guise of a minstrel. Their love is mutual, but both desire to please their respective kingdoms more than themselves. When they discover that they are to marry each other after all, their joy is boundless.

ECLECTIC-PATHÉ

"When Fate Was Kind." (Pathe. Three reels.)—A melodrama in which a false friend tries to destroy the happiness of a married couple by causing the husband to appear to be too much interested in another girl. The girl in question has suffered a misfortune in the past which she wishes kept secret, and thus comes under the control of the villain. Finally the scapegrace brother of the husband discloses the plot, and there is general happiness.

"Max and the Fair M. D." (Pathe. One reel.)—An entertaining comedy featuring the clever Max Linder, who is now at the front with the French army. After much trouble he wins a woman doctor as his bride, but then he has troubles of his own owing to her extensive practice. Finally he ejects all the patients and feels happy.

WORLD FILM CORPORATION

"The Dancer and the King." (Five reels. Monday., Nov. 30.)—Featuring Cecil Spooner as the Dancer. Victor Southerland is the King, Arthur Evers the Minister, Howard Lang is Giles and Marquita Dwight the Countess. The supporting cast is quite poor, and some of the principals do not perform as well as might be expected. The dancer, who has been made a duchess by the king, puts the evil powers in

the kingdom who attempt to dethrone him to rout. The photography of the offering is not up to standard. There are some good chances for dramatic moments during the story, but for some reason they have been spoiled by the queer actions of some of the actors. As a whole the picture will amuse.

HEPWORTH-AMERICAN

"Through the Valley of Shadows." (Turner films. Four reels.)—Although the idea embodied in this picture is rather old it is rendered exceptionally entertaining by the concise and finished interpretations given by the members of the cast, principals and supernumeraries alike. Some excellent situations enliven the story, and not one of them has been at all neglected. Detailed and pleasant touches give the film a distinct air of realism. At the opening of the story we see the physician, so busy in his profession that he has no time to devote to his wife. She becomes strangely attracted to an actor, and one day her husband surprises her in the other man's arms. She is commanded to leave her home, and after many trials and tribulations she is finally reconciled to him. The only improbable point in the story appears when Alice, the doctor's wife, steps in and plays the leading part in a motion picture. Here she meets the man who came between her and her husband. She stabs him while going over a scene of the play, but he recovers. Florence Turner appears as Alice and Mr. Clifford as her husband. Henry Vibart is cast as Mailing, the heavy. The rest of the cast are entirely capable and well suited to their parts.

"Universal Animated Weekly, No. 141." (Wed., Nov. 18.)—Of the twelve subjects that comprise this reel six of them have reference to the European war which still affords interesting material for the pictures. The other items of note are: President Wilson attending the unveiling of the statue erected to commemorate General Philip Kearney, at Arlington, Va.; Governor Colquitt, of Texas, presenting a silver service set to the U. S. S. *Texas*, and the closing of the Chicago Stock Yards. The reel ends with more of Hy Mayer's famous cartoons.

A Hint Is as Good as a Hundred Dollars

if you have sense enough to take it and use it in time.

There Are \$100 Hints

in every issue of

Motion Picture News
Take "Live Wire Exhibitors"
as an example.

One Exhibitor Added \$300

to his WEEKLY REVENUE
with one of the ideas in that
department.

BUT—He Was a
LIVE WIRE:
ARE YOU?

"THE CIRCUS MAN"

(Lasky-Paramount—Five Reels)

REVIEWED BY PETER MILNE

ONE cannot but assume that "The Rose in the Ring," was exceptionally difficult to transform into a picture. This will be all the more apparent after one has seen "The Circus Man," which is based on the celebrated novel by George Barr McCutcheon. The hard obstacles which loomed up in the path of the director, Oscar Apfel, were, no doubt, many and trying to surpass, in order to give the picture the finished completeness that it possesses.

In the first place there are three distinct stories in the picture, which are not very strongly connected. This fact, of course, necessitated the introduction of a greater number of characters than one usually sees in a five reel picture.

The fact that they are only slightly confused and then only in a few scenes, is a strong point in favor of the producers. The



BRADDOCK THREATENS COL. GRAND'S LIFE

stories, even though they bear only slight relation to one another until the end, are cleverly constructed and entertaining.

The first few scenes are devoted to a youth, David Jennison, who is accused of killing his father, when in reality a scheming relation is the offender. He escapes from the law and joins a traveling circus, where he falls in love with the daughter of the circus man. After his name has been cleared by the manoeuvrings of a newly found friend, Dick Cronk, he leaves the circus. The picture then drops David for a time, and shows how Braddock, the circus man, quarrels and leaves his wife, because he thinks her false. Later after Colonel Grand, the other man, has been killed by Dick's crippled brother, husband and wife are reunited, and David and Christine are happily married.

Theodore Roberts has the stellar role of Braddock, the circus man. He has a reputation to uphold as a character man and most certainly accomplishes it. In the first part of the picture he is a disgraceful inebriate, and in the latter part, is fully repentant, begging the forgiveness of his wife, which he receives. Mr. Roberts is such a good actor that one wouldn't mind seeing a little bit more of him, as he is scarcely in evidence until the final scenes.

Jode Mullally has the juvenile role of David Jennison, and Florence Dagmar is Christine, the girl he marries. The rest of the cast consisting of Fred Montague, Howard Hielsman, Raymond Halton, Mable Van Buren, Billy Elmer, Herbert Whitehead and James Neil are capable and thoroughly versed in their respective parts.

As a great part of the action takes place beneath the circus tent, the realism of these scenes is essentially important for the success of the picture. Life in the saw dust ring has been admirably portrayed, scenes in the dressing rooms, under the tent itself, with the attending audience, and the various acts taking place in the ring are as realistic as one could ask for. The photography in all the scenes is very good.

Except for the fact that the plots wander apart from one another in a few places the film is an excellent one. And even though this fact will cause slight confusion, the entire production is so much better than many multiple reel subjects, that it is better than the ordinary picture.

"THIRTY YEARS OF A GAMBLER'S LIFE"

(Pathe—Three Reels)

REVIEWED BY CLIFFORD H. PANGBURN

ALTHOUGH it must be admitted that this picture is a little depressing, it holds the interest, and at the same time presents a powerful picture of the misery which is sure to follow if a passion for gambling is indulged in.

Made in France, the film shows that care and elaborateness of settings which characterize most of the productions of Continental studios. The cast is composed of French actors who have learned that gesticulatory acting is not appreciated by American audiences and have reduced it to a welcome minimum.

A young man of some wealth is engaged to a beautiful girl. His father gives him \$20,000 with which to buy her a wedding present. A false friend induces him to gamble with the money and it is all lost in a crooked gambling house. This trouble almost leads to the young man's arrest, as he gives notes for a similar necklace at a "fence."

The affair is patched up and the wedding takes place, but the husband has become fascinated by gambling and dissipates his wife's fortune as well as his own. After thirty years he is practically on the streets and his wife lives in a cellar. Finally he plans a murder, only to discover in time that his intended victim is his own son, who had been sent away to an uncle when a little boy. This sobers him so that he never gambles again, but his life is nevertheless ruined.

"A CHRISTMAS CAROL"

(Cosmofotofilm—One Reel)

REVIEWED BY CLIFFORD H. PANGBURN

MANY productions of Charles Dickens' most popular story have been made for the screen, but there has never been one which surpassed this. In the matter of photography alone it is a model. As everyone knows, a large part of the action concerns ghosts. This calls for an extended amount of trick photography, but it is so well done in this film that the spectator forgets that there is any trick about. He seems to be seeing real ghosts, if the expression be allowed.

The cast is a good one, and the settings are well handled. The general result is a film which the great author himself could view without a shock were he alive today.

ALBUQUERQUE BUILDS NEW STUDIO

Special to MOTION PICTURE NEWS

Los Angeles, Nov. 23.

WORK on the erection of studio buildings on a 3,000-acre tract of ground in the San Fernando valley, 21 miles north of Los Angeles, leased by the Albuquerque Film Company, was commenced the first of this week. Negotiations for the use of the land have been completed by Gilbert P. Hamilton, president of the company, and he hopes to be working his companies at the new studio within 30 days.

The tract of ground enables the company to make every kind of a valley or mountain scene, and is so situated that the players may be transported either to a city location or one by the ocean in 30 minutes by the automobiles of the company.

The first picture to be made at the new studio, no doubt, will be one of three reels, the company's contract calling for one picture a month for the United Motion Picture Producers' program.

LOUISVILLE LOCAL COLOR IN CALIFORNIA

THE cabbage patch of "Mrs. Wiggs of the Cabbage Patch" is not a cabbage patch at all, but a little alley in Louisville, Ky.

When the California Motion Picture Corporation decided to present Mrs. Rice's story in photoplay form it wished to show the cabbage patch. So camera men were sent to Louisville, where many photographs of the little alley were made.

These were sent to the San Rafael studios of the producing organization, and there in the center of its eight acre tract the little cabbage patch was rebuilt.

Record of Current and Coming Releases

GENERAL FILM PROGRAM

RELEASES OF NEXT WEEK

Monday, November 30, 1914.

BIOGRAPH—A Mother's Way, D., 1000.....	16535
EDISON—Wood B. Weed Goes Snipe Hunting, C., 1000	16541
ESSANAY—A Maid of War, 1000.....	16543
KALEM—Her Bitter Lesson, D., 2000.....	16536
LUBIN—Fate's Tangled Threads, Beloved Adventurer No. 12, D., 1000.....	16544
SELIG SPECIAL—In the Days of the Thundering Herd, D., 5000.....	16544
SELIG—Unrest, D., 2000.....	16538
VITAGRAPH—Everything Against Him, D., 1000.....	16540
SELIG—Hearst-Selig N. Pictorial No. 79, N., 1000.....	16542

Tuesday, December 1, 1914.

BIOGRAPH—The Closing Web, D., 2000.....	16552
EDISON—The Girl of the Open Road, D., 1000.....	16545
ESSANAY—The Buffer, D., 1000.....	16546
KALEM—Bud, Bill and the Waiter, C., 1000.....	16551
LUBIN—Coupon Collectors, C., and for a Widow's Love, C., Split Reel.....	16550
SELIG—The Rival Stage Lines, C., 1000.....	16547
VITAGRAPH—Saved from a Life of Crime, D., 2000..	16548

Wednesday, December 2, 1914.

EDISON—A Double Elopement, C., 1000.....	16554
ESSANAY—The Club Girls and the Four Times Veteran, C., 1000.....	16557
KALEM—The Prodigal, D., 2000.....	16555
LUBIN—The House of d'Or, D., 2000.....	16560
SELIG—The Lion Hunter, D., 1000.....	16559
VITAGRAPH—The Mysterious Mr. Davey.....	16558

Thursday, December 3, 1914.

BIOGRAPH—In Quest of a Story, 1000.....	16562
ESSANAY—Sophie's Fatal Wedding, C., 1000.....	16563
LUBIN—The Grip of the Past, D., 1000.....	16564
VITAGRAPH—The Man That Might Have Been, D., 1000	16566
SELIG—Hearst-Selig News Pictorial No. 80, N., 1000..	16567

Friday, December 4, 1914.

BIOGRAPH—Making Them Cough Up, C., and Bertha, the Buttonhole Maker, Split Reel.....	16576
EDISON—Who Goes There? C., 2000.....	16568
ESSANAY—The Place, the Time and the Man, D., 2000	16570
KALEM—The Devil and Mrs. Walker, C., 1000.....	16572
LUBIN—A Believer in Dreams, D., 1000.....	16575
SELIG—Which Ham Is Schnappsmeier's, C., and Love's Acid Test, C., Split Reel.....	16573
VITAGRAPH—The Methods of Margaret, C., 1000....	16574

Saturday, December 5, 1914.

BIOGRAPH—The Deacon's Son, D., 1000.....	16583
EDISON—It's a Bear, C., 1000.....	16577
ESSANAY—Broncho Billy's Judgment, D., 1000.....	16578
KALEM—The Stolen Engine, D., 1000.....	16582
LUBIN—Brown's Cook, C., and He Wanted His Pants, C., Split Reel.....	16579
SELIG—Her Sister, D., 1000.....	16584
VITAGRAPH—Bunny's Little Brother, C., 1500, and Flowery California, E., 500.....	16580

RELEASES OF THE WEEK AFTER

Monday, December 7, 1914.

BIOGRAPH—Just a Kid, C., 1000.....	16535
EDISON—Crystals, Their Making, Habits and Beauty, E., 500, and Buster Brown Causes a Commotion, C., 500	16536
ESSANAY—Sweedie and The Hypnotist, C., 1000.....	16543
KALEM—The Price of Silence, D., 2000.....	16536
LUBIN—Through Desperate Hazards, D., 1000.....	16544
SELIG—The Mystery of the Seven Chests, D., 2000....	16544
SELIG—Hearst-Selig News Pictorial, No. 81, N., 1000.	16542
VITAGRAPH—The Moonshine Maid and the Man, D., 1000	16540

Tuesday, December 8, 1914.

BIOGRAPH—Cousin Pons, D., 2000.....	16552
EDISON—The Rose at the Door, D., 1000.....	16545
ESSANAY—Mrs. Trenwith Comes Home, C., 1000....	16546
KALEM—In Dutch, C., 1000.....	16551
LUBIN—He Made His Mark, C., and Dobs at the Shore, C., Split Reel	16550
SELIG—Saved by a Watch, D., 1000	16547
VITAGRAPH—Sunshine and Shadows, D., 2000.....	16548

Wednesday, December 9, 1914.

EDISON—A Matter of High Explosives, C., 1000.....	16554
ESSANAY—The Fable of the Bush-League Lover Who Failed to Qualify, C., 1000.....	16557
KALEM—The Mystery of the Yellow Sunbonnet, D., 2000	16555
LUBIN—A Recent Confederate Victory, C., 2000.....	16560
SELIG—The Abyss, D., 1000	16559
VITAGRAPH—The Athletic Family, C., 1000.....	16558

Thursday, December 10, 1914.

BIOGRAPH—For Her People, D., 1000.....	16562
ESSANAY—Sophie's Sweetheart, C., 1000.....	16563
LUBIN—The Man from the Sea, D., 2000.....	16564
SELIG—Hearst-Selig No. 82, N., 1000.....	16566
VITAGRAPH—Pure Gold, D., 1000.....	16567

Friday, December 11, 1914.

BIOGRAPH—And She Never Knew, D., 1000.....	16576
EDISON—The Best Man, D., 2000.....	16568
ESSANAY—Every Inch a King, D., 2000.....	16570
KALEM—The Bold Banditti and the Rah Rah Boys, C., 1000	16572
LUBIN—On Moonshine Mountain, D., 1000.....	16575
SELIG—One Kiss, 1000.....	16573
VITAGRAPH—A Strand of Blonde Hair, C., 1000.....	16574

Saturday, December 12, 1914.

BIOGRAPH—Diogenes Weekly No. 13, C., and Saved by Their Chee-ild, C., Split Reel.....	16583
EDISON—The Stenographer, D., 1000.....	16577
ESSANAY—Broncho Billy's Dad, D., 1000.....	16578
KALEM—The Flying Freight's Captive, D., 1000.....	16582
LUBIN—Sam and the Bully, C., and The Fresh-Air Cure, C., Split Reel	16579
SELIG—The Soul Mate, C., 1000.....	16584
VITAGRAPH—How to Do It and Why, or Cutey at College, C., 2000.....	16580



CRITERION



DANIEL WEBSTER

gave as his definition for that word: Any approved or established rule for test by which facts, principles, opinions and conduct are tried in forming a correct judgment respecting them; briefly—a standard

KRITERION SERVICE

MEANS ALL OF THAT

EVERY DAY A COMEDY

EVERY DAY A DRAMA

EVERY DAY A SPECIAL

EVERY SUNDAY A KRITERION ★ SUBJECT

Registered Under Following Brands

ROBBIN—Drama
 PARAGON—Drama
 THISTLE—Comedy
 NAVAJO—Drama
 SANTA BARBARA—Comedy and Drama
 ALHAMBRA—Comedy and Drama
 PUNCH—Comedy
 TRUMPS—Drama

If you will accept good advice, communicate with us immediately and make arrangements for a screen demonstration, also to get acquainted with our distributing agent in your territory.

KRITERION SERVICE

MICA FILM CORPORATION

220 West 42nd Street

New York City



RECORD OF CURRENT AND COMING RELEASES — Continued

UNIVERSAL PROGRAM RELEASES OF NEXT WEEK

Monday, November 30, 1914.

IMP—The Coward, D., 2000..... 4330
 VICTOR—Mary Fuller in "A Lonely Salvation," D.... 4332

Tuesday, December 1, 1914.

CRYSTAL—Charlie Woos Vivian, and The Barber Shop
 Feud, Split Reel 4341
 GOLD SEAL—Called Back, D., 4000..... 4337

Wednesday, December 2, 1914.

ANIMATED WEEKLY—Weekly No. 143, N., 1000.... 4346
 ECLAIR—The Girl Stage Driver, D., 2000..... 4343
 JOKER—The Wise Guys, C., 1000..... 4342

Thursday, December 3, 1914.

IMP—The Philanthropist, D., 1000..... 4347
 REX—The Mystery of the Sea View Hotel, D., 1000... 4348
 STERLING—Snitz's Wedding Day, C., 1000..... 4350

Friday, December 4, 1914.

NESTOR COMEDY—When Lizzie Gets Her Shine, C.,
 1000 4357
 POWERS—The Heart of a Magdalene, D., 1000..... 4352
 VICTOR—Father Buys a Bale, C., 1000..... 4354

Saturday, December 5, 1914.

101 BISON—The Foundlings of Father Time, D., 2000 4357
 FRONTIER—The Circle of Gold, D., 1000..... 4356
 JOKER—A Dream of a Painting, C., and Educational
 Split Reel 4355

Sunday, December 6, 1914.

ECLAIR—The Higher Impulse, D., 1000..... 4362
 L-KO—Fido's Dramatic Career, C., 1000..... 4361
 REX—The Lion, the Lamb and the Man, D., 2000..... 4359

RELEASES OF THE WEEK AFTER

Monday, December 7, 1914.

IMP—The Outcome, Mary Pickford Reissue, D., 1 Reel.
 STERLING—Billy's Charge, C., 1 Reel.....
 VICTOR—Terrence O'Rourke, The Inn of the Winged
 Gods, D., 2 Reels.....

Tuesday, December 8, 1914.

CRYSTAL—Vivian's Cookies and Whose Baby, C., Split
 Reel
 GOLD SEAL—The District Attorney's Brother, D., 2
 Reels
 NESTOR—The Widow's Last, D., 1 Reel.....

Wednesday, December 9, 1914.

ANIMATED WEEKLY—Weekly No. 144, N., 1 Reel.
 ECLAIR—For the Mastery of the World, D., 3 Reels..
 JOKER—The Genii of the Vase, and Educational.....

Thursday, December 10, 1914.

IMP—Three Men Who Knew, D., 2 Reels.....
 REX—No release this week.....
 STERLING—His New Job, C., 1 Reel.....

Friday, December 11, 1914.

NESTOR—Their Ups and Downs, C., 1 Reel.....
 POWERS—Adventures of the Nimble Dollar, D., 1 Reel
 VICTOR—The Little Gray Home, D., 2 Reels.....

Saturday, December 12, 1914.

101 BISON—The Trail Breakers, D., 2 Reels.....
 FRONTIER—Her Higher Ambition, D., 1 Reel.....
 JOKER—Love Disguised, and Educational, Split Reel..

Sunday, December 13, 1914.

ECLAIR—The Mountain Traitor, D., 1 Reel.....
 L-KO—The Rural Demons, C., 1 Reel.....
 REX—A Night of Thrills, D., 2 Reels.....

MUTUAL PROGRAM RELEASES OF NEXT WEEK

Monday, November 30, 1914.

AMERICAN—The Beggar Child, D., 2000..... 02664
 RELIANCE—Our Mutual Girl No. 46, 1000..... 02666
 KEYSTONE—Leading Lizzy Astray, C., 1000..... 02667

Tuesday, December 1, 1914.

THANHOUSER—The Centre of the Web, D., 2000.... 02669
 MAJESTIC—Old Good for Nothing, D., 1000..... 02671
 BEAUTY—Cupid and a Dress Coat, C., 1000..... 02672

Wednesday, December 2, 1914.

BRONCHO—A Romance of Old Holland, D., 2000.... 02674
 AMERICAN—The Strength of Ten, D., 1000..... 02676
 RELIANCE—The Lucky Shot, D., 1000..... 02677

Thursday, December 3, 1914.

DOMINO—The Vigil, D., 2000..... 02679
 KEYSTONE—Shot Guns That Kick..... 02681
 MUTUAL WEEKLY—No. 101, 1000..... 02682

Friday, December 4, 1914.

KAY BEE—Mother of the Shadows, D., 2000..... 02684
 PRINCESS—The Creator of Hunger, D., 1000..... 02686
 THANHOUSER—Naidra the Dream Woman, D., 1000. 02687

Saturday, December 5, 1914.

RELIANCE—Who Shot Bud Walton? D., 2000..... 02688
 KEYSTONE—Getting Acquainted 02690
 ROYAL—Sherman Was Right—It's Very Trying..... 02691

Sunday, December 6, 1914.

MAJESTIC—A Question of Courage, D., 2000..... 02692
 KOMIC—Mr. Hadley's Uncle (Bill No. 12), C., 1000... 02694
 THANHOUSER—The Amatur Detective, C., 1000.... 02695

RELEASES OF THE WEEK AFTER

Monday, December 7, 1914.

AMERICAN—Out of the Darkness, D., 2000.....
 KEYSTONE SPECIAL—His Pre-historic Past, C., 2000
 KEYSTONE—Title not announced, C., 1000.....
 RELIANCE—Our Mutual Girl No. 47, 1000.....

Tuesday, December 8, 1914.

BEAUTY—Limping Into Happiness, C., 1000.....
 MAJESTIC—Her Brave Hero, 1000.....
 THANHOUSER—The Reader of Minds, D., 2000.....

Wednesday, December 9, 1914.

AMERICAN—The Girl in Question, D., 1000.....
 BRONCHO—The City of Darkness, D., 2000.....
 RELIANCE—Forest Thieves, D., 1000.....

Thursday, December 10, 1914.

DOMINO—Not of the Flock, D., 2000.....
 KEYSTONE—Not yet announced, C., 1000.....
 MUTUAL WEEKLY—No. 102, N., 1000.....

Friday, December 11, 1914.

KAY BEE—Fortunes of War, D., 2000.....
 PRINCESS—In the Conservatory, D., 1000.....
 MAJESTIC—In Wild Man's Land, D., 1000.....

Saturday, December 12, 1914.

KEYSTONE—Not yet announced, C., 1000.....
 RELIANCE—On the Ledge, D., 2000.....
 ROYAL—Percy the Milliner, C., 1000.....

Sunday, December 13, 1914.

KOMIC—The House Breakers, C., 1000.....
 MAJESTIC—Dorothy in the Garret, 1000.....
 THANHOUSER—When East Meets West, 1000.....

RELEASE DATES FOR READY REFERENCE

GENERAL FILM PROGRAM

BIOGRAPH

- 11-19. A Fowl Deed, C..... 528
- 11-20. The Girl and the Miser, D.....1000
- 11-21. Blacksmith Ben, D..... 999
- 11-23. All on Account of the Cheese, C..... 305
 Thrown Off the Throne, C..... 693
- 11-24. The Romance of a Poor Young Man,
 D..... 2023
- 11-26. The Way Back, D..... 998
- 11-27. His Old Pal's Sacrifice, D.....1000
- 11-28. Little Miss Make-Believe, D.....1000
- 11-30. A Mother's Way, D.....1000
- 12- 1. The Closing Web, D.....1000
- 12- 3. In Quest of a Story, D.....1000
- 12- 4. Making Him Cough Up, C.....
 Bertha, the Buttonhole-Maker.....
- 12- 5. The Deacon's Son, D..... 1000
- 12- 7. Just a Kid, C.....1000
- 12- 8. Cousin Pons, D.....2000
- 12-10. For Her People, D.....1000
- 12-11. And She Never Knew, D.....1000
- 12-12. Saved by Their Chee-ild! and Diogenes
 Weekly No. 13, C.....1000

EDISON

- 1-17. A Moment of Madness, D.....1000
- 11-18. Buster Brown and the German Band,
 Cart..... 400
 A Millinery Mix-up, C..... 600
- 11-20. What Could She Do? D.....3000
- 11-21. Dickson's Diamonds, D.....1000
- 11-23. His Chorus Girl Wife, D.....1000
- 11-24. A Gypsy Madcap, D.....1000
- 11-25. The Temple of Moloch, D.....1000
- 11-27. The King's Move in the City, D.....2000
- 11-28. The Last of the Hargroves, D.....1000
- 11-30. Wood B. Wedd Goes Snipe, C.....1000
- 12- 1. The Girl of the Open Road.....
- 12- 2. A Double Elopement, C.....1000
- 12- 4. Who Goes There? C.....2000
- 12- 5. It's a Bear, C.....1000
- 12- 7. Crystals, Their Making and Beauty, E.. 500
 Buster Brown Causes a Commotion, C.. 500
- 12- 8. The Rose at the Door, D.....1000
- 12- 9. A Matter of High Explosives, C.....1000
- 12-11. The Best Man, D.....2000
- 12-12. The Stenographer, D.....1000
- 12-14. The Flirt, C.....1000
- 12-15. The Vanishing of Olive, D.....1000
- 12-16. On Christmas Eve, D.....1000
- 12-18. The Colonel of the Red Hussars, D.....1000
- 12-19. The Birth of Our Saviour, D.....1000

ESSANAY

- 11-21. Broncho Billy's Scheme, D.....1000
- 11-23. Sweedie at the Fair, C.....1000
- 11-24. Beyond Youth's Paradise, D.....1000
- 11-25. The Fable of Aggie and the Aggra-
 vated Attacks, C.....1000
- 11-26. Snakeville's Reform Wave, C.....1000
- 11-27. Scars of Possession, D.....2000
- 11-28. Broncho Billy's Double Escape, D.....1000
- 12- 1. The Buffer, D.....1000
- 12- 2. The Fable of "The Club Girls and the
 Four Times Veteran," C.....1000
- 12- 3. Sophie's Fatal Wedding, C.....1000
- 12- 4. The Time, the Place and the Man.....2000
- 12- 5. Broncho Billy's Judgment, D.....1000
- 12- 7. Sweedie and the Hypnotist, C.....1000
- 12- 8. Mrs. Trenwith Comes Home, C.....1000
- 12- 9. The Fable of the Bush-League Lover
 Who Failed to Qualify, C.....1000
- 12-10. Sophie's Sweetheart, C.....1000
- 12-11. Every Inch a King, two reels, D.....2000
- 12-12. Broncho Billy's Dad, D.....1000

KALEM

- 11-28. The Girl at the Throttle, D.....
- 11-30. Her Bitter Lesson, D.....2000
- 12- 1. Bud, Bill and the Waiter, C.....1000
- 12- 2. The Prodigal, D.....2000
- 12- 4. The Devil and Mrs. Walker, C.....1000
- 12- 5. The Stolen Engine, D.....1000
- 11-24. Tough Luck Smith, C.....
- 11-25. The Girl and the Explorer, C.....2000
- 11-27. Ham the Iceman, C.....
- 12- 7. The Price of Silence, Alice Joyce
 Series, D.....2 reels
- 12- 8. In Dutch, C.....1 reel
- 12- 9. The Mystery of the Yellow Sun-
 bonnet, D.....2 reels

- 12-11. The Bold Bandit and the Rah Rah
 Boys, C.....1 reel
 The Invisible Power, Special, D....4 reels
- 12-12. The Flying Freight's Captive, The
 Hazards of Helen, D.....1 reel
- 12-14. The Smugglers of Lone Isle, D...2 reels
- 12-15. Cupid Backs the Winners, C.....1 reel
- 12-16. The Hate That Withers, D.....2 reels
 The School for Scandal, D.....4 reels
- 12-18. Through the Keyhole, C.....1 reel
- 12-19. The Black Diamond Express, Haz-
 ards of Helen, D.....1 reel

LUBIN

- 11-23. The Beloved Adventurer, No. 11, D..1000
- 11-24. Mother's Baby Boy, C..... 400
 He Wanted Chicken, C..... 600
- 11-25. The Making of Him, D.....2000
- 11-25. Was His Decision Right? D.....2000
- 11-26. He Waits Forever, D.....1000
- 11-27. You Can't Beat Them, C..... 400
 The Servant Girl's Legacy, C..... 600
- 11-30. The Beloved Adventurer, Series No.
 12, D.....1000
- 12- 1. Coupon Collectors, C..... 400
 For a Widow's Love, C..... 600
- 12- 2. The House of D'Or, D.....2000
- 12- 3. The Grip of the Past, D.....2000
- 12- 4. A Believer in Dreams, D.....1000
- 12- 5. Brown's Cook, C..... 400
 He Wanted His Pants, C..... 600
- 12- 7. The Beloved Adventurer, Series No.
 13, D.....1000
- 12- 8. He Made His Mark, C..... 400
 Dob's at the Shore, C..... 600
- 12- 9. A Recent Confederate Victory, D....2000
- 12-10. The Man From the Sea, D.....2000
- 12-11. On Moonshine Mountain, D.....1000
- 12-12. Sam and the Bully, C..... 400
 The Fresh Air Cure, C..... 600
- 12-14. The Beloved Adventurer, No. 14, D..1000
- 12-15. It Lured Hubby, C..... 400
 Weary Willie's Rags, C..... 600
- 12-16. The Bomb, D.....2000
- 12-17. When the Blind See, D.....2000
- 12-18. The Comedienne's Strategy, C.....1000
- 12-19. Who's Who? C..... 400
 Shall Curfew Ring To-Night? C..... 600

- 11-24. The Scapegoat, D.....1000
- 11-25. The Butterfly's Wings, D.....1000
- 11-26. Hearst-Selig News Pictorial, N.....1000
- 11-27. A Surprise Party, C.....1000
- 11-28. The Fates and Ryan, D.....1000
- 11-30. Unrest, D.....2000
- 12- 1. The Rival Stage Line, C.....1000
- 12- 2. The Lion Hunter, D.....1000
- 12- 4. Which Ham Is Schnappmier's? C.....1000
 Lover's Acid Test, C.....1000
- 12- 5. Her Sister, D.....1000
- 12- 7. The Mystery of the Seven Chests, D.2000
- 12- 8. Saved by a Watch, D.....1000
- 12- 9. The Abyss.....1000
- 12-11. One Kiss.....1000
- 12-12. The Soul Mate.....1000
- 12-14. The Lure of the Windigo.....2000
- 12-15. The Man From the East.....1025
- 12-16. The Test.....1000
- 12-18. The Tail of a Coat..... 850
- 12-19. One Traveler Returns.....1000

VITAGRAPH

- 11-18. Fixing Their Dads, C.....1000
- 11-19. Too Much Burglar, C.....1000
- 11-20. The Professional Scapegoat, C.....1000
- 11-21. Mary Jane Entertains, C.....2000
- 11-23. The Level, D.....1000
- 11-24. The Old Flute Player, D.....2000
- 11-25. Netty or Letty, C.....1000
- 11-26. Cause for Thanksgiving, C.....1000
- 11-27. The Curing of Myra May, C.....1000
- 11-28. Convict, Costumes and Confusion, C..2000
- 11-30. Everything Against Him, D.....1000
- 12- 1. Saved From a Life of Crime, D.....2000
- 12- 2. The Mysterious Mr. Davey, D.....1000
- 12- 3. The Man That Might Have Been, D..1000
- 12- 4. The Methods of Margaret, C.....1000
- 12- 5. Bunny's Little Brother, C..... 500
 Flowers California, E..... 500
- 12- 7. The Moonshine Maid and the Man, D.1000
- 12- 8. Sunshine and Shadows, D.....2000
- 12- 9. The Athletic Family, C.....1000
- 12-10. Pure Gold, D.....1000
- 12-11. A Strand of Blond Hair, C.....1000
- 12-12. How to Do It and Why, or Cutey at
 College, C.....2000

RELEASE DAYS

GENERAL FILM PROGRAM

- Monday—Biograph, Edison, Essanay, Hearst-Selig News Pictorial, Kalem, Selig, Vitagraph.
- Tuesday—Biograph, Columbus, Edison, Essanay, Geo. Kleine, Lubin, Selig, Vitagraph.
- Wednesday—Edison, Essanay, Kalem, Lubin, Selig, Vitagraph.
- Thursday—Biograph, Essanay, Hearst-Selig News Pictorial, Lubin, Selig, Vitagraph.
- Friday—Biograph, Edison, Essanay, Kalem, Selig, Lubin, Vitagraph.
- Saturday—Biograph, Edison, Essanay, Kalem, Lubin, Vitagraph, Selig.

UNIVERSAL PROGRAM

- Monday—Victor, Imp, Powers.
- Tuesday—Gold Seal, Crystal, Nestor.
- Wednesday—Nestor, Joker, Eclair.
- Thursday—Imp, Rex, Frontier, Sterling, Ani-
 mated Weekly.
- Friday—Nestor, Powers, Victor.
- Saturday—Joker, Frontier, 101 Bison.
- Sunday—Rex, Crystal, Eclair, L-KO.

MUTUAL PROGRAM

- Monday—American, Keystone, Reliance.
- Tuesday—Beauty, Majestic, Thanouser.
- Wednesday—American, Broncho, Reliance.
- Thursday—Domino, Keystone, Mutual Weekly.
- Friday—Kay-Bee, Majestic, Princess.
- Saturday—Keystone, Reliance, Royal.
- Sunday—Majestic, Komic, Thanouser.

MINA

- 12-17. The Thrilling Adventures of Count
 Verace, C.....1000

SELIG

- 11-21. Her Sacrifice, D.....1000
- 11-23. Out of Petticoat Lane, D.....1500
 Doc Yak Plays Golf, C..... 500
- 11-23. Hearst-Selig News Pictorial, N.....1000

UNIVERSAL PROGRAM

ANIMATED WEEKLY

- 11-25. Weekly No. 142, N.....1000
- 12- 2. Weekly No. 143, N.....1000
- 12- 9. Weekly, No. 144, N.....1 reel

101 BISON

- 12- 5. Foundlings of Father Time, D.....2000
- 12- 6. The Foundlings of Father Time, D..2000
- 12-12. The Trail Breakers, D.....2 reels

CRYSTAL

- 11-17. Oh! You Mummy, and Naughty
 Nellie, split reel.....
- 11-24. Sammie's Vacation, C.....1000
- 12- 1. Charlie Woos Vivian, and The Bar-
 ber Shop Feud; split reel.....
- 12- 8. Vivian's Cookies, and Whose Baby, C.,
 split reel.....

ECLAIR

- 11-25. The Heiress and the Crook.....2000
- 11-29. The Ghost of the Mine, D.....1000
- 12- 2. For the Mastery of the World, D...3000
- 12- 2. The Girl Stage Driver, D.....2000
- 12- 6. The Higher Impulse, D.....1000
- 12- 9. For the Mastery of the World, D...3 reels
- 12-13. The Mountain Traitor, D.....1 reel

FRONTIER

- 11-21. A Relic of Olden Days.....
- 12- 5. The Circle of Gold, D.....1000
- 12-12. Her Higher Ambition, D.....1 reel

GOLD SEAL

- 11-24. The Mysterious Rose, My Lady
 Raffles Series, D.....2000
- 12- 1. Called Back, D.....4000
- 12- 8. The District Attorney's Brother, D..2 reels
- 12-15. The Ghost of Smiling Jim, D.....2 reels



So new in method—so fresh in manner—these one reel comedies will mark an era in the progress of the motion picture art. No funnier or more skillfully executed pictures have ever enriched the service of the

General Film Co.,

whose incomparable program has always been the exhibitors' standard of quality. MinA Films will add just that tingle of youth and spirit necessary now and then to rouse up and stimulate the interest of the motion picture fan. Arrange for the first MinA Film Release

December 17th

Book it through your nearest "G. F." branch office or other licensed exchanges, and remember that a failure to serve you with MinA Films means a loss of business to you. High art posters, ones and threes and an extraordinary publicity campaign go with every release.

The first MinA Film will be The Thrilling Adventures of Count Verace, one reel.



This comedy features Mlle. Valkyrien, the famous Danish film star, and was directed by Milton H. Fahrney.

MELIES MFG. CO. N.Y.

RELEASE DATES FOR READY REFERENCE — Continued

IMP

- 11—9. The Stronger Love, Mary Pickford Reissue, D.2000
 11—12. Peg of the Wilds, D.2000
 11—16. The Treasure Train, D.2000
 11—19. The Universal Boy in "Cupid and the Fishes"2000
 11—23. His Gratitude, Mary Pickford Reissue, D.1000
 11—26. Human Hearts, D.3000
 11—30. The Coward, D.2000
 12—3. The Young Philanthropist, D.1000
 12—7. The Outcome, Mary Pickford Reissue, D.1 reel
 12—10. Three Men Who Knew, D.2 reels
 12—14. The Mill Stream, D.2 reels

JOKER

- 11—24. The Tricky Flunkie, C., and La Rochelle, E., Split Reel.
 11—28. He Married Her Anyhow, C., and Eccentric Comiques, E., Split Reel.
 12—2. The Wise Guys, C., and The Ascension of Theschynig Platt, Switzerland1000
 12—5. A Dream of a Painting, and The Porpoise Fisheries, E.; split reel.
 12—9. The Genii of the Vase, and Educational, D., split reel.
 12—12. Love Disguised, and Educational, split reel.

L-KO

- 12—6. Fido's Dramatic Career, C.1000
 12—13. The Rural Demons, C.1 reel

NESTOR

- 10—23. Cupid Pulls a Tooth, and Mt. St. Bernard, Switzerland; split reel.
 10—27. The Wall of Flame, D.
 11—3. The Boy Major, D.
 11—6. Those Were the Happy Days, C.2000
 11—10. The Two Thieves, D.
 11—13. When the Girls Were Shanghaied, C.
 11—20. When Their Brides Got Mixed, C.
 India's Defender of the British Empire, E.
 11—24. As We Journey Through Life, D.1000
 12—8. The Widows Last, D.1 reel
 12—11. Their Ups and Downs, C.1 reel

NESTOR COMEDY

- 12—4. When Lizzie Got Her Polish, C.1000

POWERS

- 11—6. Nan of the Hills, D.
 11—13. Sissy Dobbins' Oil Magnet, C.
 11—20. A Scenarist's Dream, C.
 11—27. Sissy Dobbins, Oil Magnet, D.1000
 12—4. The Heart of a Magdalene, D.1000
 12—11. Adventures of the Nimble Dollar, D.1 reel

REX

- 11—1. The Vagabond, D.2000
 11—5. Let Us Have Peace, C.2000
 11—8. The Link That Binds, D.2000
 11—12. The Shoemaker's Eleventh, C.
 11—15. The Chorus Girl's Thanksgiving, D.2000
 11—19. His Uncle's Will, D.2000
 11—22. Traffic in Babies, C.
 11—26. Slow, but Sure, C.2000
 11—29. Lights and Shadows, D.
 12—3. The Mystery of the Sea View Hotel, D.2000
 12—6. The Lion, the Lamb and the Man, D.2000
 12—13. A Night of Thrills, D.2 reels

STERLING

- 12—3. Love, Luck and Candy, C.1000
 12—7. Billy's Charge, C.1 reel
 12—10. His New Job, C.1 reel

UNIVERSAL L&E

- 10—6. The Neglected Wife.
 10—13. Mary Green's Husband, and Educational, C.
 10—13. Mary Green's Husband, and The Monkey Cabaret, C., split reel.

VICTOR

- 11—20. For the People, D.2000
 11—23. Terrence O'Rourke, The Empire of Illusion, D.2000
 11—27. Mary Fuller in The Heart of Night Wind, D.2000
 11—30. A Lonely Salvation, Mary Fuller, D.1000
 12—4. Father Buys a Bale, C.1000
 12—7. Terrence O'Rourke—The Inn of the Winged Gods, D.2000
 12—11. The Little Gray House, D.2 reels

MUTUAL FILM PROGRAM

AMERICAN

- 11—18. Beppo, D.1000
 11—20. Old Enough to Be Her Grandpa, C.1000
 11—23. In the Candle Light, D.2000
 11—25. The Archaeologist, D.1000
 12—2. The Strength of Ten, D.1000
 12—7. Out of the Darkness, D.2000
 12—9. The Girl in Question, D.1000
 12—14. In Tune, D.2000
 12—16. The Silent Way, D.1000

BEAUTY

- 11—17. When Queenie Came Back, C.1000
 11—24. As a Man Thinketh, D.1000
 12—1. Cupid and a Dress Coat, C.1000
 12—8. Limping Into Happiness, C.1000
 12—15. Her Younger Sister, D.1000

BRONCHO

- 11—25. The Cross in the Desert.2000
 12—2. A Romance of Old Holland.2000
 12—9. The City of Darkness.2000
 12—16. The Panther.

DOMINO

- 11—12. The Friend.2000
 11—19. Nipped.2000
 11—26. The Mills of the Gods.2000
 12—3. The Vigil.2000
 12—10. Not of the Flock.2000
 12—17. The Political Feud.2000

KAY-BEE

- 11—6. In the Clutches of the Gangster.2000
 11—13. The Hateful God.2000
 11—20. The Master of the House.2000
 11—27. A Crook's Sweetheart.2000
 12—4. Mother of the Shadows.2000
 12—11. Fortunes of War.

KEYSTONE

- Catalina Islands, split reel.
 10—22. Love Siege, C.1000
 10—24. Stout Heart but Weak Knees, C.1000
 10—26. Shot in the Excitement, C.1000
 10—26. Dough and Dynamite, C.2000
 10—29. Gentlemen of Nerve, C.1000
 10—31. Cursed by His Beauty, C.1000
 11—2. Lovers' Post Office, C.1000
 11—5. Curses They Remark'd, C.1000
 11—7. His Musical Career, C.1000
 11—9. His Trysting Places, C.2000
 11—12. An Incompetent Hero, C.1000
 11—14. How Heroes Are Made, C.1000
 11—16. Fatty's Jonah Day, C.1000
 11—19. The Noise of Bombs, C.1 reel
 11—21. Fatty's Wine Party, C.1 reel
 11—23. His Taking Ways, C.1 reel
 11—23. The Sea Nymphs, C., special.
 11—26. His Halted Career, C.1 reel
 11—28. Among the Mourners, C.1 reel
 11—30. Leading Lizzie Astray, C.1 reel
 12—3. Shotgun That Kick, C.1 reel
 12—5. Getting Acquainted, C.1 reel
 12—7. His Pre-Historic Past, special.2 reels

KOMIC

- 11—22. Ethel Has a Steady (No. 11)
 11—29. A Corner in Hats.
 12—6. Bill No. 12.
 12—13. The Housebreakers.
 12—20. Bill and Ethel at the Ball (No. 13) ..
 12—27. Love and Business.

MAJESTIC

- 11—8. The Tear That Burned.2000
 11—10. The Niggard.
 11—13. The Folly of Ann.
 11—15. The Odalisque.2000
 11—22. The Saving Grace.2000
 11—24. Another Chance.
 11—29. The Sisters.2000
 12—1. The Old Good for Nothing.
 12—6. A Question of Courage.
 12—8. Her Brave Hero.
 12—11. In Wildman's Land.
 12—13. Dorothy in the Garret.
 12—15. At Dawn.

MUTUAL WEEKLY

- 11—15. No. 94.
 11—22. No. 95.
 10—27. No. 96.
 11—3. No. 97.
 11—10. No. 98.
 11—17. No. 99, N.1000
 11—26. No. 100, N.
 12—3. Weekly, No. 101, N.

PRINCESS

- 10—23. The Face at the Window.
 10—30. The Dead Line.
 11—6. When Vice Shuddered.
 11—13. Seeds of Jealousy.
 11—20. The Bad Mistake.
 11—27. The Wild, Woolly West.
 12—4. The Creator of Hunger.
 12—11. In the Conservatory, D.1000
 12—18. When Fate Rebelled, D.1000

RELIANCE

- 11—16. Our Mutual Girl No. 44.
 11—18. The Hidden Message.
 11—21. His Responsibility.2000
 11—23. Our Mutual Girl No. 45.
 11—25. They Never Knew.
 11—27. The Hop Smugglers.
 11—28. The Kaffir's Skull.2000
 11—30. Our Mutual Girl No. 46.
 12—2. The Lucky Shot.
 12—5. Who Shot Bud?
 12—7. Our Mutual Girl, No. 47.
 12—9. Forest Thieves.
 12—12. On the Ledge.2000
 12—14. Our Mutual Girl, No. 48.
 12—16. The Joke on Yelltown.
 12—19. The Beat of the Year.
 12—21. Our Mutual Girl, No. 49.

ROYAL

- 11—7. Max's Money.
 11—14. A Fortune in Pants.
 11—21. Love Finds a Way.
 11—28. Before and After.
 12—5. Sherman Was Right—It's Very Trying
 12—12. Percy the Milliner, C.1000

THANHOUSER

- 10—20. Old Jackson's Girl.2000
 10—25. Mr. Cinderella.
 10—27. A Madonna of the Poor.2000
 11—1. Shep's Race with Death.
 11—3. The Turning of the Road.
 11—8. Keeping a Husband.
 11—10. The Terror of Anger.
 11—13. The Chasm.
 11—15. The Man with the Hoe.
 11—17. Pawns of Fate.2000
 11—22. A Messenger of Gladness.
 11—24. Mrs. Van Ruyter's Stratagem.2000
 11—29. A Denver Romance.
 12—1. The Center of the Web.2 R.
 12—4. Naidra, the Dream Woman.
 12—6. The Amateur Detective.
 12—8. The Reader of Minds.2 R.
 12—13. When East Meets West.
 12—15. The Barrier of Flames.2 R.
 12—20. Sid Nee's Finish.

RELEASE DATES FOR READY REFERENCE — Continued

FEATURE RELEASES

ALCO FILM CORPORATION

ALL STAR

- 10— 5. The Nightingale, D.....5 parts
- 10—19. Shore Acres5 parts
- Nov. 23. Education of Mr. Pipp.....4 parts
- Dec. 28. Garden of Lies.....

CALIFORNIA MOTION PICTURE CORP.

- 11— 2. Salomy Jane5 parts
- Mrs. Wiggs of the Cabbage Patch..

LIFE PHOTO FILM CORPORATION

- Oct. The Ordeal, D.....5 parts
- Dec. 7. Springtime
- The Avalanche

POPULAR PLAYS AND PLAYERS

- 10—12. The Ragged Earl, D.....
- 10—26. Michael Strogoff, D.....5 parts
- 12—21. The Tigress

B. A. ROLFE PHOTO PRODUCTIONS

- Nov. Rip Van Winkle.....5 parts
- The Three of Us.....

TIFFANY MOTION PICTURE CORP.

- Heart of Maryland.....

ALLIANCE FILMS CORPORATION

COSMOS FEATURE FILM CORPORATION

- Lena Rivers, D.....5 parts
- Nov. 30. Hearts and Flowers, D.....5 parts
- The Little Girl That He Forgot...

EXCELSIOR FEATURE FILM CO.

- 11—23. When Fate Leads Trump.....
- The Under Trail.....

FAVORITE PLAYERS

- 11—16. The Man Who Could Not Lose...
- The Last Chapter.....

MASTERPIECE FILM COMPANY

- 11— 9. The Hoosier Schoolmaster.....5 parts
- The Truth Wagon.....

PROGRESSIVE MOTION PICTURE CO.

- 11— 2. McVeagh of the South Seas, D.....5 parts

SELECT PHOTO-PLAY PRODUCING CO.

- 10—26. At the Old Cross Roads, D.....5 parts

BOX OFFICE ATTRACTION CO.

BALBOA

- Nov. Little Jack3 reels
- Nov. 10. Message of the Mind.....3 reels
- Nov. 17. The Call of the Heart.....2 reels

NEMO

- Oct. Through Fire and Water.....2 reels
- Oct. Seeds of Jealousy.....3 reels
- Nov. Bitter Sweets3 reels

WHITE STAR

- Nov. The Mask2 reels
- Nov. 10. To Love and to Hold.....2 reels
- Nov. 17. Vengeance of the Flames.....3 reels

BOX OFFICE ATTRACTIONS—Special Features

- 11— 9. Life's Shop Window.....
- 11—19. The Walls of Jericho.....
- 11—29. The Thief

BLINKHORN PHOTOPLAYS

- Nov. The Witness Invisible, D.....3 reels
- Nov. The Aviator Trait, D.....3 reels

COSMOFOTOFILM CORPORATION

- Nov. For Home and Country.....2 parts
- Nov. She Stoops to Conquer.....4 parts
- Nov. The Two Columbinas and A Christmas Carol
- Nov. Called Back4 parts
- Nov. Beauty and the Barge.....4 parts

ECLECTIC FILM COMPANY

- Nov. Pathé Daily News, No. 77, N.....1 part
- Nov. Perils of Pauline, No. 18, D.....2 parts
- Nov. The Police Dog (Bray Cartoon), C...1 part
- Nov. The Friend of Birds, E.....1 part
- Nov. The Toreador's Oath, D.....3 parts
- Nov. Pathé Daily News, No. 78, N.....1 part
- Nov. The Fireman and the Girl, D.....3 parts
- Nov. Pathé Daily News, No. 79, N.....1 part
- Nov. Whiffles Wins the Winsome, C.....675 ft.
- Nov. Colombo, Scenis300 ft.
- Nov. Max and the Fair M.L.D., C.....1 part
- Nov. When Fate Was Kind, D.....3 parts
- Nov. Pathé Daily News, No. 80, N.....1 part
- Nov. More Than Queen, D.....4 parts
- Nov. Pathé Daily News, No. 81, N.....1 part
- Nov. Perils of Pauline, No. 19, D.....2 parts
- Nov. Jolts of Jealousy, C.....1 part
- Nov. Thirty Years of a Gambler's Life, D.3 parts
- Nov. Pathé Daily News, No. 82, N.....1 part
- Nov. The Stolen Birthright, D.....3 parts
- Nov. Pathé Daily News, No. 83, N.....1 part

ITALA FILM COMPANY

- Nov. Cabiria
- Nov. Treasure of the Louzats.....4 parts
- Nov. Jules Porel—Serpent.....3 parts

KINETOPHOTE CORPORATION

- 10—26. Markia, or The Destruction of Carthage5 reels
- 11— 2. Born Again5 reels
- 11—16. The Coming Power.....4 reels
- 11—23. The Spirit of the Poppy.....6 reels
- 12— 7. The Span of Life.....5 reels
- 12—21. The Little Jewess.....4 reels

OZ FILM COMPANY

- Oct. Patchwork Girl of Oz.....5 parts
- Oct. His Majesty, The Scarecrow of Oz.5 parts
- Nov. The Last Egyptian.....5 parts

CONTINENTAL FEATURES

KAY BEE

- The Battle of Gettysburg.....

KEYSTONE

- Zu Zu, the Band Leader.....

MAJESTIC

- Ruy Blas

MUTUAL SPECIAL

- Mexican War Pictures.....
- Seeing South America with Roosevelt.

NEW MAJESTIC

- Sapho

N. Y. MOTION PICTURE

- The Wrath of the Gods.....

R & M

- The Great Leap.....
- The Gangsters of New York.....
- The Battle of the Sexes.....
- The Floor Above.....
- The Dishonored Medal.....
- The Mountain Rat.....
- Home, Sweet Home.....
- The Avenging Conscience.....

THANHOUSER

- Moths
- Robin Hood
- A Legend of Provence.....
- Frou-Frou
- Joseph In the Land of Egypt.....
- Cardinal Richelieu's Ward.....
- Dope

PARAMOUNT PICTURES

BOSWORTH

- 10— 1. Pursuit of the Phantom.....5 parts
- 10—19. Hypocrites!
- 11—23. The Country Mouse, C.-D.....4 parts

BOSWORTH-SMALLEYS

- 12—17. False Colors, D.....5 parts

FAMOUS PLAYERS

- 11— 9. Man from Mexico.....5 parts
- 11—30. Mrs. Black Is Back.....
- 12—21. Step Sisters, D.....5 parts
- 12—28. The Crucible, D.....5 parts
- 12—31. The Millien, D.....4 parts

JESSE LASKY COMPANY

- 11—16. The Rose of the Rancho.....5 parts
- 11—26. The Man from Home.....5 parts
- 12— 7. Ghostbreaker, D.....5 parts

LASKY-LIEBLER

- 12—24. Cameo Kirby, D.....5 parts

PICTURE PLAYHOUSE FILM COMPANY, INC.

- 11— 2. For King and Country.....
- 11—10. The Last Dance.....
- 11—18. The Wild Flower.....
- 11—26. The Black Envelope.....
- 12— 2. Convict 555
- 12—10. Partners

UNITED FILM SERVICE

WARNER'S FEATURES, INC.

EVANS

- 11—27. Pagliacci, D.2000
- 12— 7. Everyone, D.2000

FEATURES IDEAL

- 11— 9. The Last Chord, D.....3000
- 11—16. The Nihilist's Daughter, D.....3000
- 11—25. Zandori's Secret, D.....3000
- 12— 1. The Wolf's Prey, D.....3000

GAUNTIER

- 11—30. The Little Rebel, D.....2000
- HUMANOLOGY FILM PRODUCING CO.
- 12— 7. The Price He Paid, D.....5000

LUNA

- 11—12. Reuben's Busy Day, C.....1 reel
- 11—19. Sage Brush Leading Lady, C.....1 reel
- 12—26. Soul Mates, C.....1000
- 12— 2. Mountain Goat, C.....1000

MILLER BROTHERS

- 11—16. Rainbow's End, D.....3000
- 11—23. Mexican Hatred, D.....3000
- 11—30. Harvest Romance, D.....1000
- 12— 7. Romance of Coyote Hill, D.....1000

MITTENTHAL

- 11— 8. The Terror of a Great City.....3 reels

PREMIER

- 11—14. Gypsy's Warning, D.....1 reel
- 11—21. Bandit of Devil's Gap, D.....1 reel
- The Prospector's Warning.....1 reel
- 11—28. As a Man Chooses, D.....1 reel
- 12— 5. Prospector's Warning, D.....1 reel
- 12— 5. Stung by a Bee, C.....1 reel

SAVOIA

- 11— 8. The Last Chord.....3 reels

STARLIGHT

- 11—10. The Villain Still Pursued Her, C..1 reel
- 11—17. Noisy Neighbors, C.....1 reel
- 11—23. Help! Murder! Police! C.....1 reel
- 12— 1. Sadie as She Never Was, C.....1 reel

SUPERBA

- 11— 8. Prince Charlie, C.....1 reel
- 11—15. Taste of High Life, C.....1 reel
- 11—23. Dr. Jekyll and Mr. Hyde, D.....1 reel
- 11—29. Camille as She Never Was, C.....1 reel

WARNER'S FEATURES

- Oct. The Adventures of Kitty Cobb, D...
- Oct. False Pride Has a Fall, C.....3 parts
- Oct. The Hypnotic Violinist, D.....3 parts
- Even Unto Death, D.....
- Nov. The Serum of Reason.....4 parts

WORLD FILM CORPORATION

- 10—26. When Broadway Was a Trail...5 parts
- 11— 2. Across the Pacific.....5 parts
- 11— 9. The Wishing Ring.....5 parts
- 11—16. One of Millions.....4 parts
- 11—23. Lola
- 11—30. The Dancer and the King.....5 parts
- 12— 7. The Seats of the Mighty.....
- 12—14. The Marked Woman.....
- 12—21. As Ye Sow.....
- 12—28. The Pit
- 1—11. Wildfire

By Arrangement with the Liebler Co., California M. P. Corporation Presents

BEATRIZ MICHELENA

AS

"LOVEY MARY"

in

MRS. WIGGS

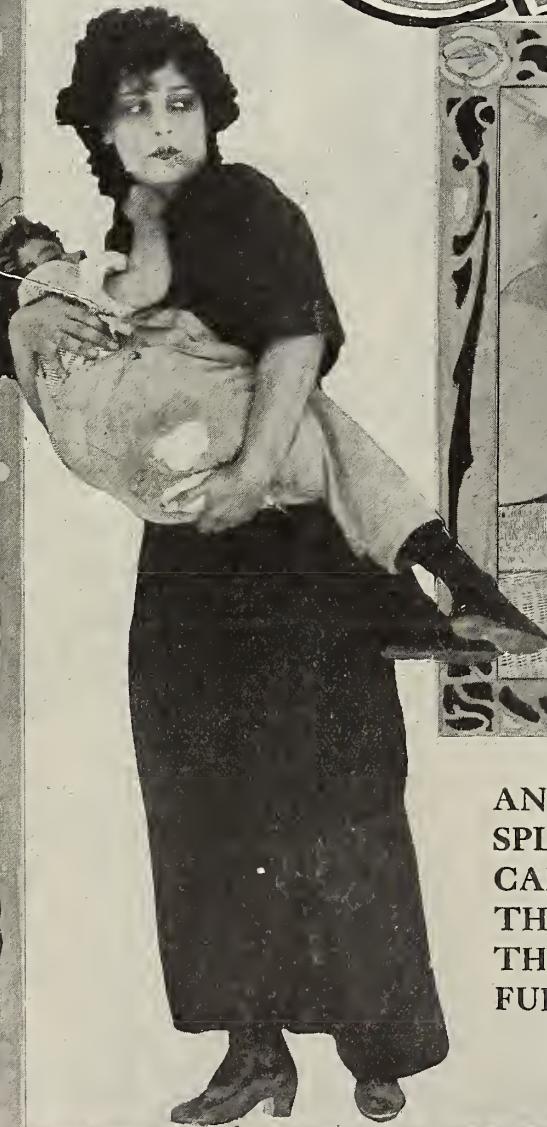

ANYONE WHO HAS READ THOSE TWO
SPLENDID BOOKS BY ALICE HEGAN RICE
CAN WELL IMAGINE THE POSSIBILITIES
THEY CONTAIN FOR A MOTION PICTURE.
THESE POSSIBILITIES HAVE BEEN TAKEN
FULL ADVANTAGE OF WITH FINE RESULTS.

of the CABBAGE PATCH

FOUNDED UPON ANNE CRAWFORD FLEXNER'S DRAMATIZATION OF ALICE HEGAN RICE'S CELEBRATED NOVELS—"LOVEY MARY" AND "MRS. WIGGS OF THE CABBAGE PATCH." A SUPERB CAST, INCLUDING BLANCHE CHAPMAN—ANDREW ROBSON AND HOUSE PETERS AND MANY OTHERS.

RELEASED NOV. 30 ON THE

ALCO PROGRAM

THE ALCO PROGRAM IS ONE OF THE BEST PROPOSITIONS FOR THE EXHIBITOR THAT COULD BE.

IT IS A CAREFULLY THOUGHT OUT SYSTEM OF FILM SERVICE.

FROM MANUFACTURER TO EXHIBITOR IS PART OF THE IDEA.

DRAWING POWER IS THE MAIN IDEA. THE BEST KNOWN ACTORS PLAYING IN THE BEST KNOWN PLAYS DRAW THE CROWDS FOR THOSE WHO HAVE ALCO SERVICE.

ALCO FILM CORP'N
ALCO BUILDING—218 W. 42ND ST.—NEW YORK



The Wedding of Miss Hazy and Mr. Stubbins

HUGH HOFFMAN

TURNER FILMS LIMITED

PRESENTS

MISS FLORENCE TURNER

The World's Best Known Moving
Picture Artist

IN

THROUGH THE VALLEY OF SHADOWS

A Drama in Four Parts That
Compels Interest

DAISY DOODAD'S DIAL

A Comedy With A Laugh From
Start to Finish

For Open Territory, etc.,
WIRE

HEPWORTH

AMERICAN FILM CORPN.

110 West 40th St. New York City

THE ALBUQUERQUE FILM MFG. COMPANY, Inc.

Featuring that clever
Comedienne

Miss Dot Farley

Two Comedies Weekly

RELEASING THROUGH
The United Motion Picture Producers, Inc.
WHO DISTRIBUTE THROUGH
Warner's Features, Inc.

By request from many exchanges
we take pleasure in
reviving the

FRONTIER TWIN STORIES

Written and made famous by Miss Dot
Farley. Under direction of

Gilbert P. Hamilton

Farce Comedy Production
BY



ARCHER McMACKIN

Nuf Sed

WESTERN STUDIO

406 Court St. Los Angeles, Calif.

GILBERT P. HAMILTON, Pres. and Gen. Mgr.

SHUBERT FEATURES
World Film Corporation
Exclusive Rights to all
Louis J. Selznick Vice Pres & Genl. Mgr.
WILLIAM A. BRADY
 Picture Play Co. inc.
FEATURES



"The Seats of the Mighty"

By SIR GILBERT PARKER

Produced by the Colonial Motion Picture Company under the direction of T. Hayes Hunter, with

LIONEL BARRYMORE

6 ACTS

Released

December 7

A SHUBERT
FEATURE

**"THE MARKED
WOMAN"**

By OWEN DAVIS

with **BARBARA TENNANT**

5 ACTS

Released

December 14



EDELMAN

Exchanges at

BOSTON
BUFFALO
CHICAGO
ATLANTA

CLEVELAND
CINCINNATI
DETROIT
DALLAS

DENVER
INDIANAPOLIS
KANSAS CITY
LOS ANGELES

MINNEAPOLIS
NEW YORK
NEW ORLEANS
PHILADELPHIA

PITTSBURGH
SEATTLE
ST. LOUIS
SAN FRANCISCO

SALT LAKE CITY
WASHINGTON

CANADA: VANCOUVER

TORONTO

WINNIPEG

CALGARY

MONTREAL

Home Office: 130 West 46th Street, New York City

Cosmofotofilm Co

"Where the REAL FEATURES come from"

Presents Simultaneously

TWO BIG HITS



(Trade Mark)
London Film Co.



(Trade Mark)
London Film Co.



SCENE FROM "FOR HOME AND COUNTRY"
The aviator starts on his perilous duty



SCENE FROM "SHE STOOPS TO CONQUER"
'Now, you Rascal, we've caught you!'

This is a Patriotic War Drama
in Two Parts

"FOR HOME AND COUNTRY"

Produced by Harold Shaw

Filmed by the London Film Co. Copyright 1914.

A Picture full of
"Punches" and "Thrills"
in Rapid Succession:

The Best Neutral War Film of all we have had to date

This is the Original Classic Four-Reel
Comedy-Drama by Oliver Goldsmith

"SHE STOOPS TO CONQUER"

Produced by George Loane Tucker

Filmed by the London Film Co. Copyright 1914.

Featuring
JANE GAIL, HENRY AINLEY
CHARLES ROCK, and other Stars
Sparkling in subtle humor throughout and superbly enacted

STATE RIGHTS NOW SELLING!

Wire us at our expense for exclusive rights
At 501 World's Tower Building, 110 West 40th Street, New York

Cosmofotofilm Co



Tigris

TWO BIG ITALA Serials Coming



Maciste



Answering the insistent call of universal demand, a wonderful character will not be suffered to die. Tigris the Terrible, than whom in film history there is none greater, returns, the Super-Criminal, in a series of exploits extraordinary. To the many millions who witnessed his deeds of daring in the first "Tigris" no motion picture announcement could hold more promise. As "Cabiria" surpassed all other spectacles so will this transcend in power and plot and superb staging all serials filmed before.

"Maciste," the modern Apollo, whose colossal proportions make ordinary folk seem as pygmies, rightly earned in "Cabiria" the title of "the most talked about character in fictional filmdom." Round this character has been written tales of adventure, deeds accomplishable only by one whose daring dauntlessness is backed by strength immeasurable. Into imagination's depths one can go in finding tasks befitting this 20th Century Hercules. Each episode complete in itself —an entertainment entire.

EACH RELEASE APPROXIMATING FOUR REELS
STRENGTHENED BY THE MOST ELABORATE LINE OF
ADVERTISING MATTER EVER DESIGNED

TERRITORIAL RIGHTS WILL BE SOLD TO RESPONSIBLE PERSONS

Address

Harry R. Raver

Director General

Itala Film Company of America

220 West 42nd St. N.Y.C.

**ALLIANCE
PROGRAM**

**ALLIANCE
PROGRAM**

The Last Egyptian

In Five Parts

A GORGEOUS ORIENTAL ROMANCE

WITH

J. FARRELL McDONALD in the Title Role

PRODUCED BY THE OZ FILM CO.

Released Dec. 7

RELEASES

**THE KEY TO YESTERDAY
THE PATH FORBIDDEN
AT THE OLD CROSS ROADS
THE HOOSIER SCHOOLMASTER
THE MAN WHO COULD NOT LOSE
WHEN FATE LEADS TRUMP
HEARTS AND FLOWERS
THE LAST CHAPTER
THE TRUTH WAGON
THE UNDER TRAIL**

From the Novel by
Charles Nevil Buck
From the Novel by
John Hymor
From Arthur C. Aistons'
famous play
From the great American
Story by Edw. Eggleston
By Richard
Harding Davis
From Novel by
Alice M. Roberts
From the celebrated
play of the same name
By Richard
Harding Davis
From the play by
Hayden Talbot
From Novel by
Anna Alice Chapin

**CARLYLE BLACKWELL
OCTAVIA HANDWORTH
ESTHA WILLIAMS
MAX FIGMAN
CARLYLE BLACKWELL
OCTAVIA HANDWORTH
MRS. THOMAS WHIFFEN
CARLYLE BLACKWELL
MAX FIGMAN
OCTAVIA HANDWORTH**

EXCHANGES

ALLIANCE FILM SERVICE, 115 Fourth Ave., Pittsburg, Pa. A. A. Welland, Mgr. *Ohio, Western Pennsylvania, Kentucky and West Virginia.* (Kentucky exhibitors will be served from Cincinnati office after Dec. 1.)

ALL THEATRES, FILM AND ACC. CO., INC. Owners of Alliance Film Exchanges, New York State. Buffalo Office, 18 Chapin Block; S. S. Webster, Mgr.; I. Cobe, Gen. Rep. New York City Office, 126 West 46th St.

ALLIANCE FILM SERVICE, controlled by Eastern Feature Film Co., Inc., 57 Church St., Boston, Mass. *New England.*

ALLIANCE FEATURE FILM SERVICE, controlled by Mecca Feature Film Co., 130 West 46th St. *Northern New Jersey.*

ELECTRIC THEATRE SUPPLY CO., Vine and 13th St., Phila., Pa. *Southern New Jersey, Eastern Pennsylvania, Maryland, Delaware, District of Columbia.*

APEX FEATURE SERVICE, 311 Andrews Bldg., Dallas, Texas. M. Levlson, Mgr. *Texas, Arkansas and Oklahoma.*

APEX FEATURE SERVICE, 417 Rhodes Building, Atlanta, Ga. O. P. Hall, Mgr. *Virginia, North Carolina, South Carolina, Georgia, Florida, Alabama, Mississippi, Louisiana.*

CASINO FEATURE FILM CO., Dime Savings Bank Bldg., Detroit, Mich. *Michigan.*

CELEBRATED PLAYERS FILM CO., 64 West Randolph St., Chicago, Ill. *Illinois and Indiana.*

NAT A. MAGNER CO., Pacific Bldg., San Francisco, Calif.; 218 Superba Theatre Bldg., Los Angeles, Calif. *California, Nevada and Arizona.*

DES MOINES FILM SUPPLY CO., 218 Utica Bldg., Des Moines, Ia. *Iowa.*

MONARCH FEATURE FILM CO., 12th and Wyandotte Sts., Kansas City, Mo. *Missouri, Kansas and Nebraska.*

ZENITH FEATURE FILM CO., Lyceum Bldg., Duluth, Minn. *Minnesota, North and South Dakota and Wisconsin.* Milwaukee Office, 407 Manhattan Bldg.

ALLIANCE FILMS CORP.

**126 W. 46th STREET
NEW YORK CITY**

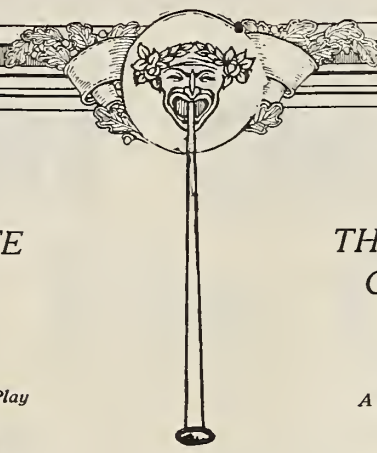

**WHEN FATE
LEADS
TRUMP**

A FOUR Part Photo Play

From the Book by

ALICE M. ROBERTS

with

GORDON DE MAINE

OCTAVIA HANDWORTH

WILLIAM A. WILLIAMS

in the Leading Roles

**THE MAN WHO
COULD NOT
LOSE**

A FIVE Part Photo Play

From the Book by

RICHARD HARDING DAVIS

with

CARLYLE BLACKWELL

*Supported by a cast of
the greatest merit*

A story of heart nterest that ranges from the heights to the depths of emotional dramatic action.

This picture is a Comedy-Drama, never tire-some and entertaining throughout its entire length.

*Previously
Released*

**THE PATH
FORBIDDEN**

*A FIVE PART
Photo Play From
The Book By
John B. Hymer*

*Released through
The
ALLIANCE
Films Corporation*



*Previously
Released*

**THE KEY TO
YESTERDAY**

*A FOUR PART
Photo Play From
The Book By
Richard Harding Davis*

Produced By



*Office:
110 W. 40th Street
New York*

*Studio:
Lake Placid
N. Y.*

Produced By



*Office
110 W. 40th St.
New York.*

*Studios
Los Angeles
California.*

GIVING THANKS!



(No. 58. Straight-from-the-Shoulder Talks by Carl Laemmle, President.)

THE man who waits for Thanksgiving before he expresses his gratitude for good bestowed upon him will never have much to be grateful for. I have never hesitated to express gratitude and appreciation. That's why I have so much to be thankful for this Thanksgiving and the other 364 days of the year.

Just now I wish to publish the Universal company's appreciation of its wonderful organization of men and women who have made it successful.

If it were not for what the French call the "esprit du corps" of the Universal staff I don't know where the Universal would be now. People who come to the Universal from other film companies are thunderstruck at the co-operation shown by each Universal employe for all of the others. They say they never saw the "happy family" theory put into practice so perfectly as it is done in the Universal family.

Every big and little department of the Universal is headed by picked men or women; experts in their lines; people who represent the survival of the fittest; men and women we have chosen by the process of elimination. For all of this the Universal is deeply grateful.

Away out in California we have a tremendous organization that is spending vast fortunes in cash every day of every week of the year. It is a vital cog in the huge Universal machinery. But it is so well oiled that it runs smoothly, without friction, without trouble of any kind. We in New York seldom have to give it thought. So perfect is the co-operation of every member of our western staff that the great Universal City is being constructed and many pictures are being produced every week without a hitch. For all of this the Universal is deeply grateful.

Away over in England is the headquarters of our whole European business. It is a tremendous organization in itself, with tremendous responsibilities. But in spite of the devastation of war it is making splendid headway. Not on the continent, of course, but in every spot that is not actually occupied by warring troops. For all of this the Universal is deeply grateful.

Our New York and New Jersey studios and factories are nearer the home office, but we rely upon the men who manage them as we do upon our western and European men. They deliver the

goods, and that is all we ask. For all of this the Universal is deeply grateful.

Away down in South America and away over in India, China, Japan and Africa the Universal organization is being built up by our own men and reaching spots never before thought of as a market for American-made moving pictures. We get brief cable reports, but outside of that we do not have to detract our attention from the greater plans which we are always making. For all of this the Universal is deeply grateful.

All over the United States and Canada there are Universal exchanges, some of which we own and some of which are privately owned. All are on exactly the same basis, and all are co-operating with a spirit that makes the heart beat a little faster with appreciation. We rely upon the men in charge and they never fail us. For all of this the Universal is deeply grateful.

All over the world we are sending men on various missions; some to take pictures; some to sell them; some to build up weak markets; some to do any other little or big thing which they are commissioned to do. Some of them we do not see for months at a time, but we know they are using their brains all the time, for they are producing results. For all of this the Universal is deeply grateful.

Here in the home office the same spirit of "all for one and one for all" pervades the atmosphere. There is no petty jealousy among departments. Each is glad to suggest schemes to another or to accept suggestions from others. The Universal is proud of every person on its staff, and we have a sneaking suspicion that they are proud of the Universal.

It was not like this in the olden days. We've not always had such a fine machine. It has creaked and groaned in the distant past. It has sputtered and spluttered, screamed and cried in business agony. But the dead past has buried its past. We are living in the NOW.

And, finally, as a climax to this Thanksgiving straight-from-the-shoulder talk, I want to say that the Universal is doubly, trebly grateful to those exhibitors who have stuck to the Universal through storm and stress; who used our program in the long ago when they even thought it was poor; but who had faith in us, and who have given us the opportunity to demonstrate the truth of the fact that their faith was not misplaced.

SPECIAL FEATURES

General Film Company

TITLE	MAKE	No. of Reels	TITLE	MAKE	No. of Reels
THIRD DEGREE	Lubin	5	MAN'S ENEMY	K. & E. Biograph	3
THOR, LORD OF JUNGLE	Selig	3	IN TUNE WITH THE WILD.....	Selig	3
THE BATTLE OF SHILOH.....	Lubin	4	THE WOLF	Lubin	6
THE LION AND THE MOUSE.....	Lubin	6	SHADOWS OF THE PAST.....	Vitagraph	3
THROUGH FIRE TO FORTUNE.....	Lubin	5	MR. BINGLES' MELODRAMA.....	Vitagraph	3
JUDITH OF BETHULIA.....	Biograph	4	MEN AND WOMEN.....	K. & E. Biograph	3
GERMINAL	Pathe	5	THE SECRET OF THE RING.....	Kleine	3
LOST IN MID OCEAN.....	Vitagraph	3	MY FRIEND FROM INDIA.....	Edison	3
A ROMANY SPY.....	Pathe	3	LIBERTY BELLES	K. & E. Biograph	3
A CELEBRATED CASE.....	Kalem	4	THE ERRING	Lubin	3
THE FULFILLMENT	Essanay	3	AMBUSHED	Essanay	3
NIGHT RIDERS OF PETERSHAM.....	Vitagraph	3	SONG OF THE SOUL.....	Kleine	3
HARDING'S HERITAGE	Pathe	3	KIT, THE ARKANSAS TRAVELER.....	Kalem	3
DAUGHTERS OF MEN.....	Lubin	5	CHIP OF THE FLYING "U".....	Selig	3
THE OTHER HALF OF THE NOTE.....	Kalem	3	FAIR REBEL	K. & E. Biograph	3
HER LADYSHIP	Selig	3	HOUSE NEXT DOOR.....	Lubin	51
GOODNESS GRACIOUS	Vitagraph	3	MY OFFICIAL WIFE.....	Vitagraph	5
OFFICER JIM	Lubin	3	UNCLE BILL	Vitagraph	3
DEATH SIGN AT HIGH NOON.....	Kalem	3	THE FORTUNE HUNTER.....	Lubin	6
GAME OF LIFE.....	Selig	3	THE VENDETTA.....	Kleine	5
THE MILITANT SUFFRAGETTE.....	Pathe	5	BAREFOOT BOY	Kalem	3
FRANCIS MARION, "THE SWAMP FOX".....	Kalem	3	THE WIFE	K. & E. Biograph	3
A MILLION BID.....	Vitagraph	5	KING OF CHANCE.....	Kalem	3
THE FATAL WEDDING.....	K. & E. Biograph	3	THE WAGES OF SIN.....	K. & E. Biograph	3
THE GAMBLERS	Lubin	5	THE PLUM TREE.....	Essanay	3
ANNE BOLEYN	Kleine	3	THE FIFTH MAN.....	Selig	3
STRUGGLE FOR LIFE.....	Pathe	5	THE GOLDEN BEETLE.....	Kleine	4
MONGREL AND MASTER.....	Essanay	3	THE WEIGHT OF A CROWN.....	Lubin	3
THE ROYAL BOX.....	Selig	4	MARAH, THE PYTHONESS.....	Lubin	3
THE CURSE OF CREED.....	Melies	5	CHARITY BALL	K. & E. Biograph	3
FACING THE FOOTLIGHTS.....	Pathe	3	HEARTS AND MASKS.....	Selig	3
BLOOD WILL TELL.....	Essanay	3	A FLORIDA ENCHANTMENT.....	Vitagraph	5
CONQUEST OF QUEBEC.....	Kalem	5	ROAD TO YESTERDAY.....	K. & E. Biograph	3
THE LIL OF THE VALLEY.....	Selig	3	THE PAINTED WORLD.....	Vitagraph	3
CLASSMATES	K. & E. Biograph	4	JUDGE NOT	Kleine	4
MAN OF THE HOUR.....	Selig	3	GARRISON'S FINISH	Selig	3
MR. BARNES OF NEW YORK.....	Vitagraph	6	POWER OF THE PRESS.....	K. & E. Biograph	4
LOVE, LUCK AND GASOLINE.....	Vitagraph	3	IN THE GLARE OF LIGHTS.....	Essanay	3
THE BILLIONAIRE	K. & E. Biograph	3	THE RED CROSS NURSE.....	Melies	3
SPORT AND TRAVEL IN CENTRAL AFRICA	Pathe	5	THE THREADS OF DESTINY.....	Lubin	5
THE GOOD FOR NOTHING.....	Essanay	4	WHEN THE LIONS ESCAPE.....	Melies	3
THE BOER WAR.....	Kalem	5	THE GENIUS	K. & E. Biograph	3
THE THUMB PRINT.....	Melies	4	STONEWALL JACKSON'S WAY.....	Lubin	3
STRONGHEART	K. & E. Biograph	3	THE INVISIBLE POWER	Kalem	4
LORD CHUMLEY	K. & E. Biograph	4	THE WOMAN IN BLACK.....	K. & E. Biograph	4
SEVEN DAYS	K. & E. Biograph	3	UNDER THE GASLIGHT.....	K. & E. Biograph	4
TREASURE OF ABDAR RAHMAN.....	Pathe	4	"413"	Vitagraph	3
'NEATH THE LION'S PAW.....	Melies	3	THE WIN(K)SOME WIDOW.....	Vitagraph	4
ONE WONDERFUL NIGHT.....	Essanay	4	THE STORY OF THE BLOOD RED ROSE.....	Selig	3
WOMAN AGAINST WOMAN.....	K. & E. Biograph	3	THE TELL TALE HAND.....	Essanay	3
IN DEFIANCE OF LAW.....	Selig	3	A POOR RELATION.....	K. & E. Biograph	3
A KINGDOM AT STAKE.....	Kleine	3	THE LOCKED DOOR	Vitagraph	3
CAPTAIN ALVAREZ	Vitagraph	6	THE TANGLE	Vitagraph	4
OTHELLO	Kleine	5	THE SPY'S FATE	Lubin	3
SHANNON OF SIXTH.....	Kalem	5	IN THE DAYS OF THE THUNDERING HERD	Selig	5
			THE STRANGE STORY OF SYLVIA GRAY.....	Vitagraph	4

VITAGRAPH

"EVERYTHING AGAINST HIM," Drama **Monday, Nov. 30th**
Circumstantial evidence convicts a man. The reappearance of his supposed victim saves him. An all-star cast.

"SAVED FROM A LIFE OF CRIME," 2-Part Drama **Tuesday, Dec. 1st**
A boy's opportunity proves his worth and makes him a man. Give the boys a chance. James Morrison, Dorothy Kelly and George Cooper in the leads.

"THE MYSTERIOUS MR. DAVEY," Comedy **Wednesday, Dec. 2nd**
Quick wit and action saves Henry much marital unhappiness. He took a chance and had a narrow escape. Sidney Drew as Henry.

"THE MAN THAT MIGHT HAVE BEEN," Drama **Thursday, Dec. 3rd**
As we dwell upon what might have been our hearts are filled with happiness or regret. This picture is a dream of happiness. Leah Baird, William Humphrey, Leo Delaney and Anders Randolph are the cast.

"THE METHODS OF MARGARET," Comedy **Friday Dec. 4th**
Sauce for the goose is sauce for the gander. He employs female help, she employs male servants. Lillian Walker as Margaret.

"BUNNY'S LITTLE BROTHER," 2-Part Comedy **Saturday, Dec. 5th**
It's hard to tell him from John. Bunny's wife thinks she sees double. John Bunny, Jay Dwiggins, as his little brother, and Flora Finch are the principals.

SIX A WEEK

"THE MOONSHINE MAID AND THE MAN," Drama. **Monday, December 7**
"SUNSHINE AND SHADOWS," Two-Part Drama. **Tuesday, December 8**
"THE ATHLETIC FAMILY," Comedy. **Wednesday, December 9**
"PURE GOLD," Drama. **Thursday, December 10**
"A STRAND OF BLOND HAIR," Comedy. **Friday, December 11**
"HOW TO DO IT AND WHY" or **"CUTEY AT COLLEGE,"**
2-Part Comedy, **Saturday, December 12**

VITAGRAPH ONE, THREE AND SIX SHEET POSTERS

The Vitagraph Company of America
East 15th St. and Locust Ave. **Brooklyn, N. Y.**

BROADWAY STAR FEATURES

RELEASED

A MILLION BID	5 PARTS	MY OFFICIAL WIFE	5 PARTS
GOODNESS GRACIOUS	3 PARTS	UNCLE BILL	3 PARTS
MR. BARNES OF NEW YORK	6 PARTS	THE PAINTED WORLD	3 PARTS
LOVE, LUCK AND GASOLENE	3 PARTS	FLORIDA ENCHANTMENT	5 PARTS
CAPTAIN ALVAREZ	6 PARTS	413	3 PARTS
SHADOWS OF THE PAST	3 PARTS	THE WIN(X)SOME WIDOW	4 PARTS
BINGLES' MELODRAMA	3 PARTS	THE TANGLE	4 PARTS
		THE LOCKED DOOR	3 PARTS

Produced by THE VITAGRAPH CO. OF AMERICA and Released Through
THE GENERAL FILM COMPANY'S SPECIAL SERVICE
By Arrangement With BROADWAY STAR FEATURE CO., Inc.

COMING

SYLVIA GRAY	4 PARTS	THE SAGE BRUSH GAL	3 PARTS
TWO WOMEN	3 PARTS	THE MAN BEHIND THE DOOR	4 PARTS
THE LITTLE ANGEL	5 PARTS	OF CANYON CREEK	From Book

State Rights Still Available for **THE CHRISTIAN** Apply Vitagraph-Liebler Feature Film Co., 116 Nassau St., N. Y.

LUBIN

THE PERFECTION OF PHOTO-MOTION

Every Exhibitor Should Book These Wonderful Pictures
(Through the General Film Special Service)

By Arrangement with Fred Mace
EVELYN NESBIT THAW
and her son, **RUSSELL WILLIAM THAW**, in
"THREADS OF DESTINY"

By Wm. H. Clifford *Direction—Joseph W. Smiley*

"STONEWALL JACKSON'S WAY"

The Best War Picture Ever Made
The Battle Scene Taken At Midnight

By Emmett Campbell Hall *Direction—Edgar Jones*

READY FOR EARLY RELEASE

EDWIN ARDEN
IN **"EAGLE'S NEST"** *Direction—Romaine Fielding*

By Edwin Arden

RAYMOND HITCHCOCK

(The Funniest Man on the Stage)

IN **"THE RINGTAILED RHINOCEROS"**

By Lawrence S. McCloskey
Direction—George W. Terwilliger

ROSE COGHLAN

And **ETHEL CLAYTON** in

"THE SPORTING DUCHESS"

By Cecil Raleigh

Direction—Barry O'Neil

By W. H. Lippert *Direction—Joseph W. Smiley*
"THE SPY'S FATE"
The Thrilling Experience of a U. S. Envoy

IN PREPARATION

A Comedy
By George Ade

"THE COLLEGE WIDOW"

Featuring **ETHEL CLAYTON** and **GEORGE SOULE SPENCER**

Direction—Barry O'Neil

SIX REGULAR RELEASES EACH WEEK

"THE BELOVED ADVENTURER," No. 12, Drama	Monday,	November 30th
"Fate's Tangled Threads"		
"COUPON COLLECTORS" { Split Reel Comedies	Tuesday,	December 1st
"FOR A WIDOW'S LOVE" {		
"THE HOUSE OF D'OR"—Two Reel Drama	Wednesday,	December 2nd
"THE GRIP OF THE PAST"—Two Reel Drama	Thursday,	December 3rd
"A BELIEVER IN DREAMS"—Drama	Friday,	December 4th
"BROWN'S COOK"		
"HE WANTED HIS PANTS" { Split Reel Comedies	Saturday,	December 5th

SPECIAL—ONE, THREE AND SIX SHEETS.

Lubin Manufacturing Company, Philadelphia, Pa.

Chicago Office:
154 West Lake Street



Marc MacDermott in a Double Role—as a Real and as a Counterfeit Bridegroom

HOW a bride, waiting at the altar for an over-due bridegroom, can actually marry a counterfeit presentment of the man she expected to wed is a wonder. Marc MacDermott takes the part of the jilted bridegroom as well as of the real benedict. The fun doesn't end there, for, as they start on their honeymoon, a detective overshadows them on the Pullman. Gertrude McCoy plays the part of the bride.

It is a dramatic adaptation of the novel entitled "The Best Man" by Grace L. H. Lutz, and is in two parts. The plot is well wrought out, the acting of a high order, while the merriment at the embarrassing situations created, make for this a lively

EDISON

reel that is bound to delight a host of pleasure seekers.

Marc MacDermott is also featured as Lord Stranleigh in "The Premature Compromise" (an adaptation of the famous "Young Lord Stranleigh" Stories, by Robert Barr), to be released Friday, Dec. 21st, in the Edison list of reels for December.

OTHER LOVE AFFAIRS IN THE DECEMBER EDISON LIST OF REELS:
"OLIVE'S OPPORTUNITIES," a series (one of which is to be released every Tuesday in December), in which Mabel Trunnelle takes

the part of "Olive." **WHO GOES THERE?** in which Walter E. Perkins again plays the part of "Topsy," as in the original play. (To be released Dec. 4th.) **A DOUBLE ELOPEMENT** (To be released Dec. 5th.) **IT'S A BEAR**—a would-be heroic swain tries to win a bride by pretending to have killed a bear. (To be released Dec. 5th.) **THE FLIRT**, who deserts his latest attraction while she is in deep water about to learn how to swim. (To be released Dec. 14th.) **ON CHRISTMAS EVE**. A young couple take back as "Santa Claus" the grandfather they have set adrift from their home. (To be released Dec. 16th.) **COLONEL OF THE RED HUSSARS**, a magnificent reel in three parts. (To be released Dec. 18th.) **MR. DALY'S WEDDING DAY**. A swindler and counterfeiter tries to bribe cabbie and police. (To be released Dec. 28th.) **THE COURTSHIP OF THE COOKS**, who compete for the widow that discovers her husband is alive and is the policeman who appears just in time. (To be released Dec. 30th.)

TRADE MARK
Thomas A. Edison
Makers of the Edison Kinetoscope, Model "D"

Thomas A. Edison, Inc. 275 Lakeside Ave.
ORANGE, N. J.

RELEASE NOV. 23rd

DIGBY BELL

in

**THE EDUCATION
OF MR. PIPP**

(5 Parts)

—DECEMBER 28th—

JANE COWL

in

**THE GARDEN OF
LIES****All Star Feature Corp.**

220 West 42d Street New York

TIGHTEN ENFORCEMENT OF FILM STORAGE LAW

NEW YORK exchanges, manufacturers, film brokers and manufacturers' agents with offices in the vicinity of Times Square are facing a serious situation following the revival of an ordinance passed January 1, 1912, at the instigation of the Bureau of Combustibles, prohibiting the storing or keeping of more than ten reels of film in a building within fifty feet of a theatre.

Summonses have been issued to a number of film concerns, demanding their appearance in General Sessions on Friday of this week, to show cause for their violation of this ordinance. This followed unexpected visits by fire and building inspectors to the offices of the companies. Where their visits were anticipated safes were found locked and bolted, and in two instances the only men who had the combinations were out of the city.

Strict enforcement of the ordinance has been rumored for several weeks, but, it is said, the matter was brought to a focus last Thursday, immediately after a fire in the offices of the American and European Film Company, in a building at 145 West Forty-fifth street. The fire started in the testing room of the company, and did damage estimated at \$50,000. Other buildings in the vicinity of Broadway and Forty-second street where film companies are located were immediately inspected, and violations of the ordinance were found in perhaps twenty places.

Amendments were made to the ordinance at the request of several of the larger exchanges. They were permitted to construct fireproof storage vaults, enclosed with a double brick wall, and a reasonable distance from elevators, stairways and air shafts.

Charles Abrams and Joseph Miles, of Films Lloyd, 220 West Forty-second street, applied to the Bureau several weeks ago for permission to construct a vault in their offices. Inspectors advised that the floor space was inadequate. Anticipating the present agitation and proposed action against film concerns, they leased a loft in a fireproof building at 345 West Fortieth street. Two big fireproof vaults will be constructed there from plans approved by the Bureau.

PENNANTS**PILLOWS****FELT AND LEATHER
NOVELTIES FOR****Premiums and
Advertising**

**INCREASE YOUR BUSINESS—
LET US FURNISH YOU SPECIAL ATTRACTIVE PREMIUMS WHICH WILL DRAW THE CROWDS.** We make a specialty of premiums for advertising purposes.

We can furnish attractive and inexpensive novelties of all kinds which will more than double your attendance whenever used. Try it! You will be more than pleased with results obtained.

*Write us for full particulars,
prices, etc.*

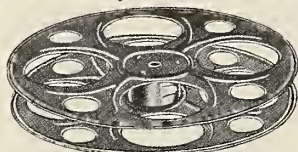
**PACIFIC PENNANT &
NOVELTY CO.**246 No. New High Street
LOS ANGELES, CAL**Perfect Projection — That's It****Our 14-in. Reel Helps**

Sent prepaid upon receipt of \$1.25 in N. Y. Draft, Money Order or Cash.

The Taylor-Shantz Co.

222 Mill St., Rochester, N. Y.

**YOU****WANT YOUR THEATRE TO PAY.****THIS MEANS****RENFAX MUSICAL
MOVIES****RENFAX FILM CO., Inc.****CHICAGO: 154 W. Lake St.****NEW YORK CITY: 110 W. 40th St.**



EDWIN AUGUST

Master Actor of the Films
has joined forces with the

KINETOPHOTE

and will produce famous plays under the K. C. emblem

EXHIBITORS EVERYWHERE ARE STILL BOOKING THE BIG KINETOPHOTE FEATURES

"THE SPIRIT OF THE POPPY"

with Edward Mackay

"THE COMING POWER"

with Lionel Adams

"THE SPAN OF LIFE"

with Lionel Barrymore

"MARKIA"

the Ambrosio Wonder Film

These exchanges are for your convenience

American Feature Film Co., 162 Tremont Street, Boston, Mass.—Maine, New Hampshire, Vermont, Massachusetts, Rhode Island and Connecticut—All New England.

Eastern Booking Offices, 1237 Vine Street, Philadelphia—Eastern Pennsylvania, Southern New Jersey, Virginia, Delaware and District of Columbia.

Eastern Booking Offices (Pittsburgh Branch, 432 Wabash Building)—Western Pennsylvania and West Virginia.

Eastern Booking Offices (Cleveland Branch, 218 Columbus Building)—State of Ohio.

K. C. Booking Co., Inc. (Chicago Branch, Mallery Building, S. E. corner of Madison and Wabash)—Illinois.

Midwest Feature Film Co., Loeb Arcade Building, Minneapolis, Minn.—Minnesota, Iowa, North and South Dakota and Wisconsin.

Atlantic Service Co., 508 Rhodes Bldg., Atlanta, Ga.—Georgia, Alabama, North Carolina, South Carolina, Mississippi and Florida.

California Film Service Corporation, 1149 Mission Street, San Francisco, Cal. (with branches in Salt Lake City, Utah, Denver, Seattle, Portland, Ore., and Los Angeles)—California, Oregon, Washington, New Mexico, Montana, Idaho, Wyoming, Colorado, Nevada, Arizona and Utah.

Dallas Film Co., Dallas Texas—Texas, Louisiana, Oklahoma and Arkansas.

ALL BOOKING THE EXCLUSIVE KINETOPHOTE PROGRAMME OF

Feature

**K. C.
BOOKING
CO.**

Incorporated

Productions

TELEPHONE: 6072 BRYANT

NEW YORK CITY

126 WEST 46TH STREET

The Christmas Motion Picture News

will have many special features covering every branch of the trade; an exceptionally striking cover in gold, red and brown; inside color pages, with specially designed head and foot pieces, in gold and green, gold, red and green and orange and black, and a six color insert—suitable for framing—of a most popular motion picture actress. All of this in addition to the regular features carried each week. The circulation is larger—at least 20%—although the advertising rates are the same. Speak now if you wish to advertise in the color pages. Forms close Dec. 8.

DECEMBER 5, 1914

Accessory News

THE CONSTRUCTION, EQUIPMENT AND OPERATION OF THE MODERN PICTURE THEATRE
VOLUME X NUMBER 22

DON'T

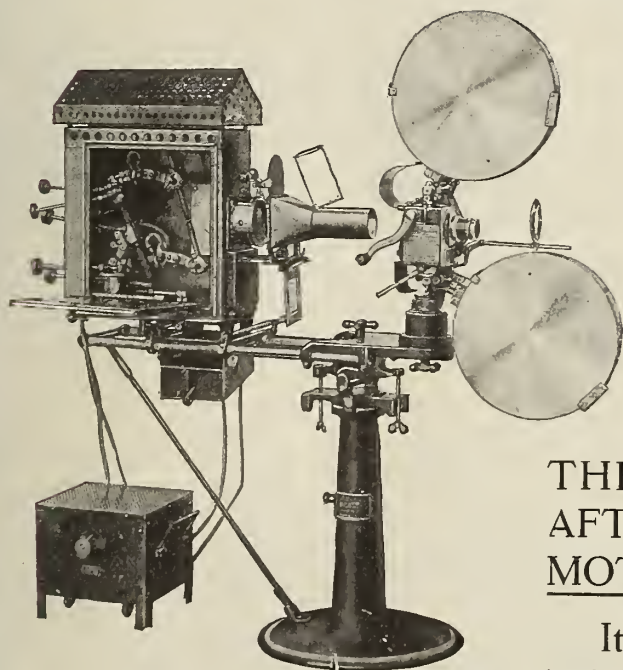

OVERLOOK THE KIND OF A PICTURE A machine will project when selecting a projector.

FOR BRIGHT PICTURES, FOR FLICKERLESS, and THAT SOFT VELVET KIND (NOT THOSE GLOOMY PICTURES WHICH HURT THE EYES FOR AN HOUR AFTERWARD) use a LATE MODEL MOTIOGRAPH.

It's the machine that uses the two inside shutters that travel in opposite direction and produce the BEST picture of any machine manufactured today. If you don't know about the MOTIOGRAPH, write us today for Motiograph Literature.

The Enterprise Optical Mfg. Co.
568 W. Randolph Street, Chicago, Ill.

EASTERN OFFICE
19 W. 23d St., New York

WESTERN OFFICE
833 Market St., San Francisco



Name

.....

.....

WYANOAK,
136 W. 52d St., N. Y.

At your expense
send full information on
publicity plan

No. 1

**We
Will Help
You Pack
Your Theatre**

**We Have Two Special
and Distinct
Exhibitor Advertising Plans**

ENDORSED BY
General Film Co.
Mutual Film Co.
Universal Film Co.

**Both Business Builders With
Human Interest Appeal**

**SEND COUPONS
FOR PARTICULARS NOW**



At your
expense
send complete
information on
advertising plan

No. 2

**Wyanoak Pub.
Company**

136 W. 52nd St.
NEW YORK

Name

.....

.....

WYANOAK PUB. CO.,
136 W. 52d St., New York.

**MENGER
& RING**

SPECIAL FEATURE FOR TO-DAY

**POSTER
AND
DISPLAY FRAMES**

**FOR MOVING
PICTURES
AND ALL
AMUSEMENTS
OF THE
BETTER KIND**

ASK FOR CATALOGUE

**302
W. 42nd
Street
New York**

**TELEPHONE
BRYANT 6621**



**PERFUMES
DISINFECTANTS**

SPRAYING DISINFECTANTS.

BOUQUET, 1 gal., \$2.50; 5 gal., \$10. Our best. Cannot be equaled in strength and fragrance.

LAVENDER, 1 gal., \$2.00; 5 gal., \$7.50. REFRESHING.

SPEARMINT, 1 gal., \$1.50; 5 gal., \$5.00. POWERFUL.

PRICES INCLUDE LARGE SPRAYER.
50 cent. credit without sprayer.

PERFUMES.

Can be used with Fans or in Clay or Plaster Paris Cones.

Cinnamon	\$2.50	
Spearmint	3.50	CONES 30 cents each.
Lavender	3.50	
Carnation	6.00	
Bouquet	6.00	

YOUR MONEY REFUNDED IF NOT SATISFACTORY

We sold the first perfumed disinfectants in this country, and on account of manufacturing and importing direct, the quality at our price cannot be beat.

GENDISCO

408 36th Street - BROOHLYN, N. Y.

10% May be deducted from above prices on any order no matter how large if check is sent together with this Coupon.

Offer only good up to January 1, 1915

Please send me the following.....

.....

.....

.....

Less discount of 10%.

Name..... Theatre.....

Address

Construction,
Equipment
and Operation

Accessory News

Everything for
the Modern
Picture Theatre

TEL. 7650 BRYANT

TWO HUNDRED AND TWENTY WEST FORTY-SECOND STREET

NEW YORK CITY

Volume X

DECEMBER 5, 1914

Number 22

A Well-Ordered Photoplay Theatre

FOR the theatre of today the best decoration and the most modern equipment go hand in hand. The time has passed when either can be neglected with any regard for receipts, from a box-office standpoint. The evolution from narrow, painted halls and converted stores to the magnificent structures especially built for the projection of motion pictures has been gradual but none the less sure.

The motion picture industry today can boast of as fine a collection of beautiful specially constructed buildings, designed for the greatest amount of comfort to the patrons, large seating capacity, and superior to the average home of the legitimate drama.

Watch Maximum Seating Capacity

As a model of what an up-to-the-minute motion picture theatre should be the Southern theatre, of Wheeling, W. Va., is a good example. Conforming throughout with the rigid city building code specifications; built of concrete, stone, and brick with steel frame; every modern improvement that would go to give better projection or more comfort to the patrons, has been installed.

The importance of proper seating is what every prospective builder of a theatre should have before him, whether contemplating erecting a new building or altering an old one.

Since the seating capacity affects the box office receipts, the tendency to put in the maximum seating capacity sometimes tends to detract from the comfort of the patrons.

The law, in some states, governs the width of an aisle, but where there is no law or ordinance and the point is left to the builder, an aisle not less than three feet six inches should be provided. Of course in a wide house two or three aisles and sometimes four are used. The plans given herewith of the Southern theatre show how this matter was treated. In no case has the width of any of the aisles been sacrificed to give space for more seats, and the width at the narrowest point exceeds five feet. Here again is the axiom "safety first" given preeminence, and a patron does not have to pass more than six seats to reach an aisle.

The elevations and plans show all the conveniences, such as retiring rooms for the audience, dressing rooms, stage and other parts of the auditorium, also the seating arrangements. The building has a ground plan of 51 x 100 feet and a seating capacity of 660. The balcony seats 160, and there is ample standing room, allowing for some 200 extra standees.

This theatre is one of the finest of its size in the South, and the plans will go further to show the modern innovations and advantages as embodied in this theatre than any mere written article.

The arrangement of the lobby, the comfort rooms, the exits, the seats, the boxes, in fact everything that would enhance the convenience and comfort of its patrons, show such careful study and thought on the part of the designer as to leave nothing to be desired from the audience's standpoint.



FRONT ELEVATION, SOUTHERN THEATRE, WHEELING, W. VA.

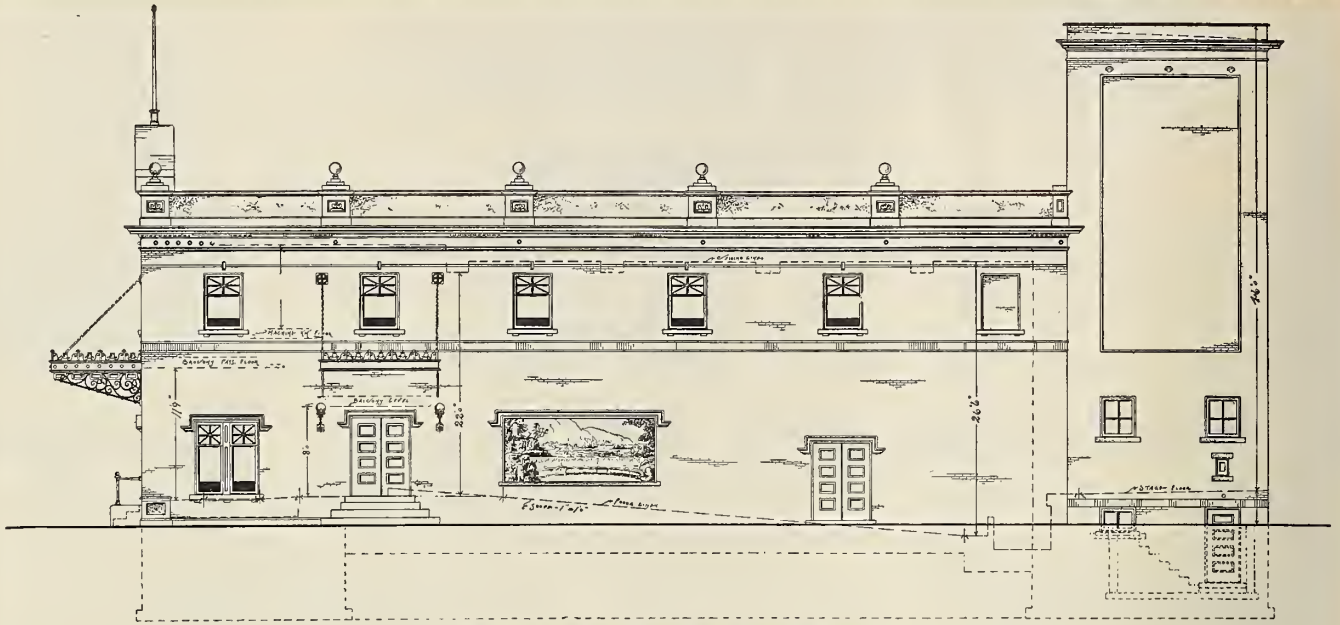

SOUTHERN THEATRE, SIDE ELEVATION

In considering the comfort of the patrons the builders had in mind, as mentioned previously, that each seat should give the maximum degree of comfort with the minimum of waste space. Particular stress was laid on "better to forego a few seats than make the aisles too narrow."

But one thing that the plans don't show is the interior decorations. That intangible something which painters call "atmosphere" in a picture is nowhere in greater demand than in theatre decoration. Especially so for the interiors. Its influence is felt to a greater extent than is generally imagined. It gives the theatre tone, and this subconscious force acting on the feelings of the audience decides as to whether or no steady patronage shall follow the initial visit to the theatre.

It is not putting it too strong when the statement is made that

"the average theatregoer has no knowledge of period styles and perhaps cares less; he does not know the difference between a Louis XV wall decoration and an Italian Renaissance panel; but as no man is absolutely dead to a sense of color and form, his latent artistic sensibilities are capable of being aroused by the subtle appeal of a harmonious blend of tints and graceful lines."

The interior decorations of the Southern theatre leave nothing to be desired, and further attention is called to this by the system of indirect lighting used to illuminate the interior.

The equipment of the theatre includes two Motiographs, a Fort Wayne compensarc, Gold Radium screen, 19 x 21 feet, and one General Electric spotlight. The seats throughout are from A. H. Andrews Co., and George H. Dieringer, with whom theatre buildings are a specialty, was the architect.

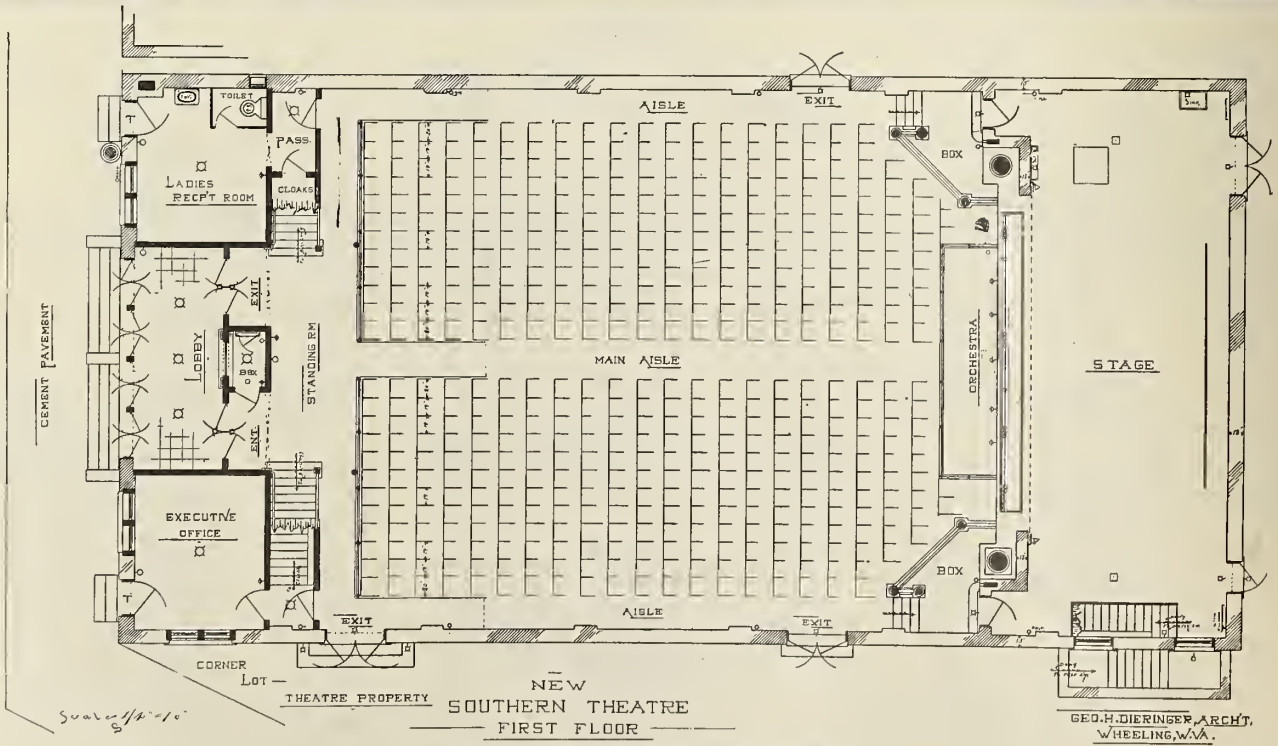

FLOOR PLAN OF THE SOUTHERN THEATRE

Projection

CONDUCTED BY HERBERT W. ANDEM

Problems That Puzzle Projection People

B. T. U., Good Ground, L. I.—Will you please tell me the ruling in New York for the size wire for the arc lamps in motion picture machine booths? Can motor machines be used? What kind of fuses are used?

Answer.—(a) The City of New York publishes, for free use to contractors, a code of rulings for electrical installations of all kinds. In this handbook it gives under "Arc lamps used as a part of a moving picture machine"—wiring to same. (lamp) must not be of a less capacity than No. 6 B. & S. gauge.

Electrical supply houses sell a class of wire called moving picture machine cable. A catalogue of a leading supply house describes it as "a cable designed for use in connection with moving picture machines where the conductor is likely to be subjected to a high temperature. The strands are of fine wires, so as to procure an extra flexible cable, and the insulation is made up of one or two braids of cotton, impregnated with a slow-burning paint, and finished on the outside with a braid of asbestos."

Such a wire is generally used for the wiring to the lamp and rheostat and is approved for this use. This code also states, under "Wires" that stranded wire (except in flexible cords) must be soldered before being fastened under clamps, or binding screws, and whether stranded or solid, when they have a conductivity greater than that of No. 8 B. & S. gauge, they must be soldered into lugs for all terminal connections, except where an approved solderless terminal connector is used.

(b) Yes, under certain conditions. It must be of an improved type. If driven by a motor, must be of a type expressly designed and approved for such operation, and when so approved, motor driven machines, when in charge of a skilled operator, may be authorized under special permission in writing, given in advance.

(c) To answer this *all* important question the code is also here-with quoted: "The leads to the lamp and its rheostat or equivalent device, must be protected by a plug cutout or open link fuses, the latter enclosed in an approved cabinet with self-closing door. Cartridge fuses will not be permitted." The tendency of operators to "tamper" with the fuses, especially of the cartridge type, has compelled a ruling that the condition of the protecting device can at all times be easily seen.

E. M. F., Ampere, N. J.—Does a small dynamo act in the same manner as a large one? Could a series wound dynamo be used for an arc lamp?

Answer.—(a) It makes no difference as to the size of a dynamo machine in its effect to generate electrical pressure, or voltage. In the smaller sized machines there will likely be difficulty experienced, at times, to get it to "pick up its voltage."

These small machines are not as efficient in transforming power and generally run at very high speed. This means more trouble to prevent vibration, and brush contact with the commutator will give trouble. (b) If you want to use a series wound machine, for the arc lamp only of a picture machine, you would be in trouble most of the time.

The burning of the carbons making a greater distance between the two carbons would create more resistance in the circuit. This would then lower the voltage of the dynamo just when it should generate more, to overcome this greater resistance. The arc across the carbons would perhaps then go out. Then it would be necessary to "build up the voltage" by holding the carbons together. Do not use this type of dynamo unless you want to have some fun for awhile. It would soon become tiresome. It is also not practical.

F. P. S., Chicago.—(a) Does a dynamo, when generating electricity, gather it from the air? (b) Does the location of a dynamo, in regard to the supply of air, influence the generating powers of the dynamo, and consequently the illuminating power of the

lights? (c) Will a dynamo, when placed in a vacuum, generate electricity?

Answer.—Sounds as if you must have worked cranking a Wims-hurst machine in a doctor's office before taking up cranking a picture machine. It is presumed that you refer to frictional or static electricity, which is seen in the air in the form of lightning, or which may be also seen from belting in cold weather.

Dynamic electricity is not produced by friction, but by induction. What is meant by induction is that a wire moved past a "pole" of a magnet so as to cut the magnetism emanating from it, the wire will be found to have set up in it electrical pressure.

The electrical pressure, or electricity, is not gathered from the air. (b) Yes, the cooler the dynamo is kept the greater the output that can be taken from it. Dry cool air should have free access to a dynamo. As the dynamo heats the voltage drops from the greater resistance offered in the windings and the field regulating rheostat will have to be adjusted to raise the voltage to that of the lamps, to make them burn brightly. (c) If a dynamo was run in a vacuum it certainly would generate.

However, its output could not be carried to the limit that it could be if air had free admission to it.

Don't Use Too Much Light for the Picture

LIGHT is necessary to project a picture. It is also true that too much light can be used for this work. An excess of light produces harsh and very disagreeable pictures.

It is the same in the projection field as it is in other fields of life; there is the person calling for more and more, as also in an audience calling louder—LOUDER—LOUDER! This person seems never satisfied.

There should be sufficient light to project a picture plainly. It does not demand, however, that a great quantity of light be used, as seems to be standard among many exhibitors.

Beyond that amount of light to give a plain picture, the operator's duty is to call the attention of his employer, be he of the more and more type, to the increased cost for electric power.

The arguments for not using too much light are many. First, the operator may mention one which ought to interest his employer's purse. "Money talks." Why not let it talk on the subject of too bright a light in a picture? It is interesting.

The "High Cost" of Light

More light beyond the point of projecting a good picture means more current consumed at the arc lamp. The bill rendered for power used is also larger. Let's see how it figures out.

At the rate of ten cents per kilowatt hour the cutting down of the current used in the arc lamp only a few amperes will amount to a goodly sum in a year's time. For an example:

For ease in the computation, we will take the figure 25.

To obtain the power in kilowatt hours we multiply the voltage by the amperes and this product in turn by the number of hours. Giving both matinee and evening shows, about six hours daily, the arc lamp is kept burning.

Then $110 \times 25 \times 6 = 16,500$ watt hours, or, 16.5 kilowatt hours each day. Running seven days the week makes this $16.5 \times 7 = 115.5$ kilowatt hours per week. For a month it is then four times this, or 460 kilowatt hours.

Now, at a ten-cent basis for power, your monthly bill for the power consumed, in the arc lamp only, is \$46.

What It Amounts to in a Year

Your employer insists that he *must* have a bright light in his pictures. So you adjust the rheostat to give, say, five more amperes, making it 30 amperes at the arc.

Recalculate, as before, but change the figure 25 to 30 amperes.

(Continued on page 110.)

NOW LISTEN!

To prove our Film Reel the BEST MADE FREE
Without any cost to you we will give you

Lang's No. 4 Film Rewinders

Your choice of one only

LANG'S 10, 12, or 14" Film Reels

THE U. S. GOVERNMENT ADOPTED REEL

The only Machine Screw assembled reel made

The only one piece Hub-Three Keyway reel on the market

The only reel that can be threaded from the outside

THE STRONGEST REEL IN EXISTENCE

10 inch, \$1.00. 12 inch, \$1.25. 14 inch, \$1.50.

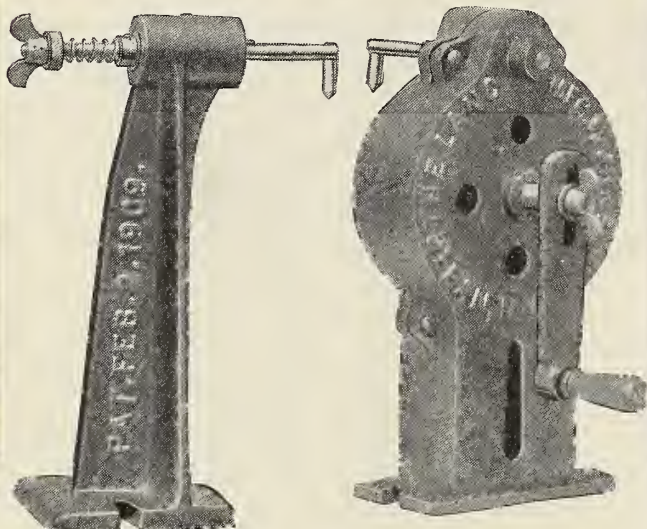

LANG'S No. 4 Film Rewinder, price \$7.50. Jointed Spindles—Adjustable Crank—Oil Cups for the Tension Bearing (Patented), Enameled Green Lettered in Gold. Massive in Construction, takes reels up to 18 inches
THE LANG MFG. WORKS, Olean, N. Y., U. S. A.

A clear picture

is as essential as a good scenario. Because the basic product is right the clearest pictures are on Eastman Film. Identifiable by the stencil mark in the margin.

EASTMAN KODAK CO.,
ROCHESTER, N. Y.

The Rex Film Renovator

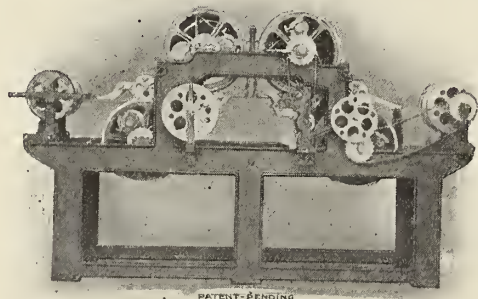

PATENT-PENDING

It is now successfully operating in three of the Laemmle Film Service Offices, working day and night, located at

No. 204 W. Lake St., Chicago, Ill.
No. 1122 Farnum St., Omaha, Neb.
Nos. 811-819 Hubbel Bldg., Des Moines, Iowa.

If it is good enough for Laemmle Offices, why is it not good for any other exchange?

Twenty-two other leading Universal, Mutual and Warner Exchanges have one.

The midget Cleaner and Noiseless Rewinder is a dandy; no more horrible noise in the operating booth while show is going on to annoy your patrons. Every Exhibitor and small exchange should have one.

Write for booklet, "Creating Good Will," which also has the best film Cement Formula. It is free.

The Rex Film Renovator Mfg. Co.

272 N. Third Street

Columbus, Ohio

WE RENOVATE FILM. WRITE FOR PRICES.

Did They Ask You To Be The Goat?

SPECULATORS—not legitimate supply men—bought large stocks of foreign carbons, hoping to unload them at fancy prices.

THEY WANTED TO TRIPLE THEIR MONEY THEY EXPECTED YOU TO PAY THE FREIGHT

Projector Carbons, "made in America," are now being successfully used throughout the country. Join the boosters. Save your money. Try out our carbons before placing your next order. Do it now.

LOOK AT THESE PRICES.

1/2 x 6 Solid	Proj. @ \$15.00	per 1000
1/2 x 6 Cored	Proj. @ 17.00	per 1000
1/2 x 12 Solid	Proj. @ 27.50	per 1000
1/2 x 12 Cored	Proj. @ 30.00	per 1000
5/8 x 6 Solid	Proj. @ 18.50	per 1000
5/8 x 6 Cored	Proj. @ 20.00	per 1000
5/8 x 12 Solid	Proj. @ 35.00	per 1000
5/8 x 12 Cored	Proj. @ 37.50	per 1000
3/4 x 6 Cored	Proj. @ 27.50	per 1000
3/4 x 12 Cored	Proj. @ 50.00	per 1000

Cash with order.

F. O. B. Cleveland, O.

What does the other fellow want you to pay?

National Carbon Company
CLEVELAND, OHIO

Projection

What have you now for the month's bill? It should be 554.4 kilowatt hours at ten cents, or \$55.44.

The difference is so near to an even ten, we may say, that to please his vanity for a bright light, the exhibitor is throwing away \$10 each month. In a year's time it is \$120. It is not a large sum.

It is worth considering, however, where a saving can be made. There are many other things to be gained along with it. If the exhibitor is not interested in this saving for himself, why not then increase the wages for your operating help to this amount per year and obtain the higher grade of operators this increased wages will attract?

By not using more light than is necessary to project a good picture there are many more things to be gained in addition to the less cost for power. Among the more important things, a more pleasing and satisfactory picture is shown the patrons of the theatre; less heat is radiated in the operator's booth; less carbon consumption in the lamp; the fewer condensing lenses cracked; films will last for a longer service, and there is less danger from film fires.

There is much that may be said about these things, and they will be taken up later. The exhibitor and the operator cannot give too much thought along these lines of economics. The audience, the exhibitor and the operator are all three materially benefited therefrom.

The Location for a Screen

THE location of a screen on the stage in motion picture theatres seems to have not concerned the exhibitor to the extent that it should. It is important, however.

There are many exhibitors who set up a screen directly in front and in the place where the stage curtain is usually hung. This location is *decidedly* wrong. The only thing that can be said in favor of such a plan is that it saves the expense for scenery or boarders to obscure the view from the stage walls.

Also, it may be said, the stage back of the screen, can then be utilized for storage room or for other purposes. Beyond this, everything stands against this location for a screen.

Why does the audience fill the middle and rear seats first and leave the front seats for the late arrivals? Simply because the screen is too near these front seats. The vision is impaired and it is much more difficult for the eyes, at this short range, to see all the action taking place in the picture.

Especially so, if the front seat be also a side one. The turning of the eyes alone cannot cover the vision from one side of the picture to the other. The head must also be turned to follow a figure crossing to the other side of the picture.

When a screen is hung further back on the stage, not only does it allow persons in the front seats to see the full picture clearly and without any physical exertion from the turning of the head, but a decidedly improved appearance of the whole front and stage of the theatre is thus obtained.

The space gained from putting the screen further back on the stage permits of placing flowers or ferns in artistically arranged

groups. This style of stage decoration always conveys a very pleasing effect to the audience.

Locating the screen further back on the stage adds only a few feet to the greater distance to the rear seats. It is so small a percentage of this distance, that the vision of the spectator is not materially affected.

Questions and Answers

Q.—Do you think a 110-volt generator would generate enough electricity to throw a clear picture on an average size motion picture screen?

A.—This question does not give sufficient information for a positive direct answer. First, the strength of current to be used should have been given. It is assumed this operator is to use direct current. About 25 amperes will give sufficient light for the average sized screen. Then, if the dynamo he wants to use has the manufacturer's name plate stating the dynamo will carry 25 amperes or more, he may be safe in using it.

Q.—How many H. P. gasoline engine would I need to turn the generator at its required speed?

A.—The smallest sized H. P. engine that may be used to run the above small generator may be determined in this manner. The unit of work in electrical energy is expressed in watts. The watt is the voltage multiplied by the strength of current given in amperes. Hence, $110 \times 25 = 2,750$ watts.

This calculation does not take into account the energy lost and gives the actual energy used at the arc. It is not necessary to go too deeply into efficiency and lost energy in the transforming of the power. It is sufficient to say, in the small generator this operator is inquiring about, the efficiency will not be above 50 per cent.

The relative H. P. of 2,750 watts equals 746 watts (equal to 1 H. P.) divided into 2,750 watts: $2,750 \div 746 = 3.68$ H. P. Add to this the 50 per cent. lost in the dynamo, which gives 5.52 H. P.

It will be wise, then, not to use a smaller sized engine to generate this small amount of electrical energy for the arc light only, than a 10 H. P. engine. This additional capacity for the engine is to take care of the loss in friction for a belt drive.

Seasoning the Program with "Local Color"

MANY motion picture operators throughout the country have hand cameras and are, perhaps, advanced amateurs in the taking of photographs. Has the idea of taking local scenes of current events and then making these views into lantern slides, been suggested by them to the manager?

There have been some. And the plan has proven a success. The wise, broad minded exhibitor will gain much free advertising by encouraging his operator in this direction of adding local color to the show.

Projecting one or two slides only, at the beginning of the show, will suffice to season the program. These slides of local scenes will create much talk from the patrons of the theatre to their

Manufacturers of the Wonderful

Rembusch Patented Glass MIRROR SCREEN

and all other kinds of

Curtains for Moving Picture Projection

GLASS SCREENS

Mirror Screen
Mirror Screen Split
Glass Transparent Screen
for Rear Projection

Phone Seven-Eleven

METALLIZED SCREENS

Gold Fibre
Silvercloth
Mirror Cloth
Seamless, with stretchers
White Opaque

F. J. REMBUSCH, Pres.

MIRROR SCREEN COMPANY

Incorporated

SHELBYVILLE, INDIANA

Mr. O. P. Sammons of Denison, Texas, bought a "Mirror Screen," and he writes that he cannot take care of the crowds. His picture is simply the talk of the community. A few second-hand screens for sale cheap.

Eastern Representative, Frank Manning, 125 W. 48th St., N. Y. Phone, Bryant 2416.

SAVE 35%
on your
CARBONS
Burn your
stubs with a
CARBON
Economizer



Pat. applied for.

Fits any lamp, gives perfect contact and conductivity made of special material, screw does not come in contact with carbon and will not weld to body of economizer; will burn upper or lower carbon to 3/4 of an inch.

OVER 1000 IN USE
"MECHANICALLY CORRECT"!!
Guaranteed to give satisfaction

\$1.25 Each. Sizes 1/2" - 3/4" - 1" Set—any sizes. \$2.00

Sent postpaid upon receipt of New York Draft, Money Order or Cash.

THE CARBON ECONOMIZER CO.
757 W. Onondaga St. Syracuse, N.Y.

THE CORCORAN RACK IS THE BEST EVER
Get No. 6 Price List
A. J. CORCORAN, INC.
9 1/2 John Street New York

There Are Several interesting business boosting schemes outlined in the "Live Wire Exhibitors" department of this issue. It will pay you to read every one of them.

friends, and their friends in turn, will be the more tempted to visit the theatre to see these pictures. Unless the scenes have been well taken in the camera, and from these good negatives slides are then made, and well made, this plan had best not be attempted. Good slides will, however, add much interest to the show. Later on **MOTION PICTURE NEWS** will print an article covering the best methods to follow in the making of good lantern slides, to assist the operators that may not have any information at hand on this interesting subject.

Puts New Curtain Coating on Market

THE J. H. Genter Co., Inc., Newburgh, N. Y., maker of the celebrated Mirroroide screen, has just placed on the market a new screen and curtain coating known as Master White. This coating is a very fine white glass preparation, guaranteed not to contain lime, glue, or whitening, and to be fire and water proof. It is very easily applied and comes ready mixed, and meets a long felt want.

During the past two weeks this firm has shipped Mirroroide screens to the following exhibitors:

H. C. Farley, Empire Theatre, Montgomery, Ala.; Kozy Theatre, Galesburg, Ill.; Lemanski Theatre, Marshfield, Oregon; Belle & Scanlon, Alamo Theatre, Jackson, Miss.; Danville Film Exchange, 107 N. Vermillion street, Danville, Ill.; L. E. Radcliff, Lancaster, Ohio; Rae Amusement Corp., University Theatre, Fordham road & Jerome av., Bronx, N. Y.; Frank Parker, Romeo, Mich.; Victor Animatograph Co., Davenport, Iowa; Mr. Stanch, Liberty Theatre, 1075 Springfield avenue, Irvington, N. J.; Thomas Lynch, Pictureland Theatre, 600 Potter street, Saginaw, Mich.; B. Frankfeld & Co., 211 Produce Exchange, New York City for Santiago, Cuba; Matlock & Foley, Ames, Ia.; The Electric Shop, Basil, O.

We Can Equip Your Theatre Complete

We are Distributors for the Powers, Edison, Motiograph and Simplex Machines, and Genuine parts, also Poster Frames, Indirect and Semi-Indirect Lighting Fixtures, Tickets, Screens, etc.

We sell for cash or on the easy payment plan.

Write today for our new catalog just off the press.

AMUSEMENT SUPPLY CO.

160 No. Fifth Avenue Chicago, Illinois

COMPENSARC

That's the device that saves Moving Picture men two-thirds on their electric light bills, and yet gives better light. Did you see our ad last week? Well, don't look it up. Just write for our

Booklet 5027

FORT WAYNE ELECTRIC WORKS
OF GENERAL ELECTRIC CO.
1704 BROADWAY
FORT WAYNE, INDIANA 733

Our Factory Is Yours!

Negative assemblers, projecting machines and an equipment second to none, with an organization of experienced people always at your **SERVICE** for **DEVELOPING** and **PRINTING**.

EVANS FILM MFG. CO.
Incorporated

416-22 WEST 216th STREET
Tel. 7652 Audubon at Broadway, New York

The **CHRISTMAS NEWS**

will be the most attractive issue of a trade journal ever published in this field. Dated December 19.

Order your extra copies **NOW**.

No orders taken after December 8.

DO IT NOW AND HAVE NO REGRETS

MANY EXHIBITORS HAVE PROVEN THE FACT THAT BY **I**NSTALLING A **M**IRROROIDE THEY HAVE **R**ECEIVED A **G**REATER **P**ATRONAGE **R**ESULTING NOT ONLY IN **S**ATISFACTION TO BOTH BUT **O**N ALL OCCASIONS THE **R**ETURNS FROM THE **I**NVESTMENT HAVE **D**EMONSTRATED **O**UR CLAIMS TO THE **I**MPORTANCE OF **P**ERFECT **P**ROJECTION **I**N YOUR CASE HAVE YOU **D**ECIDED TO **S**ATISFY YOURSELF? **E**NROLL AT ONCE IN THE **G**REAT **A**RMY OF **S**ATISFIED **U**SERS OF **MIRROROIDE**

SEND FOR SAMPLES, 3 TINTS { SILVER WHITE
SILVER FLESH
PALE GOLD } 2 FINISHES { ROUGH
OR
MATTE } OVER 8000 IN USE

Our Latest Tried—Tested—True Master White—Ready to Apply—The Whitest of the White—It Can't Crack, Peel or Rub Off—It's Fire Proof—Get a Sample of Master White—It Contains no Glue, Whiting or Lime—Be Wise—Deal With Responsible Manufacturers—Avoid the Fly By Nighters.

THE J. H. GENTER CO., INC., NEWBURGH, N. Y. The Oldest—The Only Real Screen Manufacturers With a Factory in the World.

Building and Furnishings

The Theatre as a Social Centre

HOW to keep the theatre filled at each performance. This problem is hard to solve in the small town. The exhibitor in the large cities is able to meet the situation by extensive advertising. But the available publicity in small places is limited to the use of heralds, posters and handbills of various kinds. The local paper is hardly effective. It generally comes out only once a week, and where the announcement of frequent changes of bill is necessary, fails to be of service.

How, then, can the manager of a theatre in a small town make every seat a source of perpetual income?

One way is to start a club.

Start a club?

Exactly. A club properly conducted will solve the difficulty for the small community audiences.

But in order to carry out such a scheme a manager must have a club house. He must be able to furnish the conveniences implied in the name.

But will it pay; won't it cost too much to maintain?

Not if an exhibitor carries out a plan adapted to the peculiarities of his location. Certain general rules obtain in practically every region capable of supporting a motion picture theatre.

The club idea has been made possible as an outcome of the tendency on the part of many property owners to erect a two-story structure when building a photo play house.

But there is only one way to accomplish the desired result—the club.

How can it be done on practical lines? Offer inducements to your fellow townspeople.

Broadly speaking, the plan is this: Issue season tickets, which

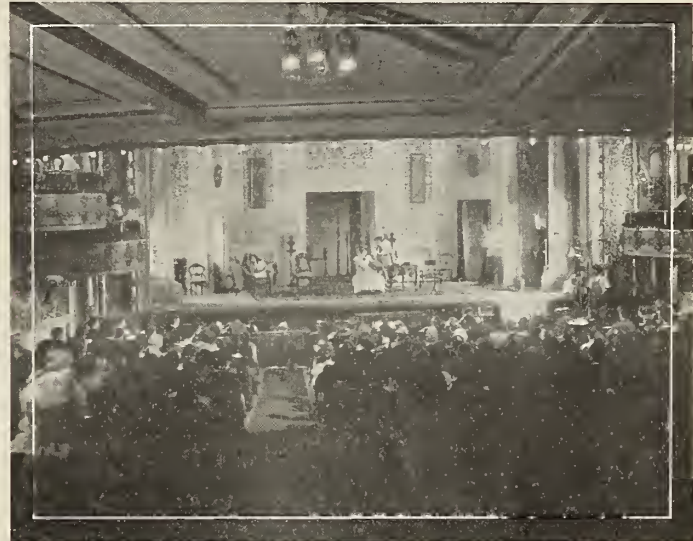

SCENE IN "FALSE COLORS" (BOSWORTH-SMALLEY FEATURE)
(Taken by Use of Winfield-Kerner Lamps)

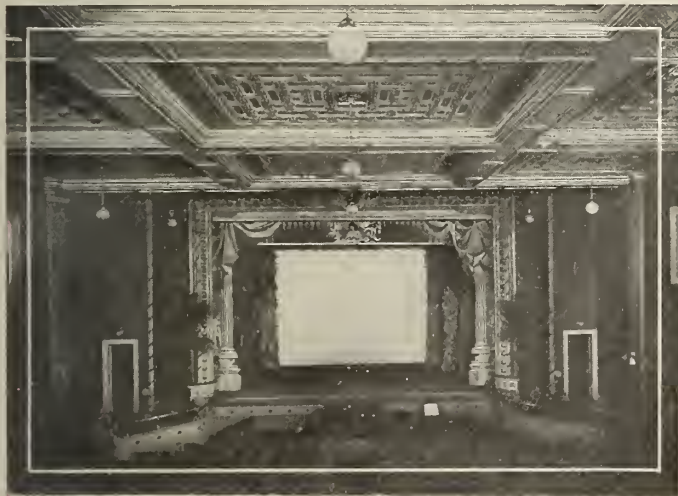

INTERIOR, SOUTHERN THEATRE, WHEELING, W. VA.

The upper floor is designed for the use of lodge meetings and other assemblages, and generally the lessee of the theatre is supposed to take the whole building.

The inauguration of a club will in all probability bring in a larger income at the end of a year than the occasional rental of the rooms for these private affairs.

A prudent manager can make his theatre an important center. This is not a hard task in a town whose social activities are limited and where the public mode of entertainment is practically confined to the motion picture theatre.

entitle the holder not only to the same seat for every new performance, but gives him the privilege of a club member. Install reading rooms, where magazines and illustrated papers are on file for the use of members. Allow them the use of the ball-room for social functions and meetings of their lodges.

Of course, the charge would have to be above the actual price of admission to the theatre in order to bring the gross receipts on a par with the amount a manager would receive from rentals.

As an additional attraction a bowling alley could be installed in the basement. Charge a fee a trifle below the price generally asked for the use of alleys.

Of course, it would be unprofitable to let members have the use of the ball-room for lodge meetings and social occasions at the bare price of the season tickets. But if the rental is calculated carefully, the manager will be able to let the club members have the use of the rooms at a figure that is an inducement. At the same time, the proprietor will not lose money by putting the rooms at the disposal of members at a rate lower than the ordinary rental.

Patrons cannot expect that. But the happy mean can be struck which will be an inducement on one hand, and on the other, give the lessee a reasonable profit.

A theatre capable of use for such a plan is the Globe, in San Pedro, California, designed by L. B. and A. L. Valk, the well-known motion picture house architects of Los Angeles.

In this building has been built bowling alleys, smoking rooms for men, a ball-room on the second floor, and, if located in a

(Continued on page 116)

Life Size Lobby PHOTOGRAPHS Boost Box Office Receipts

Original negatives of leading players of all West Coast studios in straight or character poses.

DISPLAYS NOW READY*

DISPLAYS OF COMING RELEASES

The Spoilers
St. Elmo
Little Sunbeam
The Key to Yesterday

The Man Who Could Not Lose
Terrance O'Rourke Series
Blood Red Rose
The Escape

The Avenging Conscience
Will O' The Wisp
The Hoosier Schoolmaster

The Carpet From Bagdad
The Rosary

The Truth Wagon
The Last Chapter

*Displays include either character or straight photographs.
SIZES: 8x10's, 16x20's, 30x40's, and 30x60's. WRITE NOW.

PHOTOPLAYERS' STUDIO

342 SO. BROADWAY

LOS ANGELES, CAL.

Only exclusive professional studio on Pacific Coast where 80 per cent. of American motion pictures are made.

Be sure to mention "ACCESSORY NEWS" when writing to advertisers.

Directory of New Theatres

EDITOR'S NOTE.—The information contained in the "Directory of New Theatres" is gathered by the field representatives of "Motion Picture News" and the facts and figures in each instance have been verified by them and are authentic. They may be relied upon by members of the trade.

Two Spokane Theatres Nearing Completion

EACH hoping to beat the other in its opening, contractors for the new Clemmer and Ye Liberty theatres, Spokane, Wash., located two blocks apart, are running the prettiest sort of a race. Crews work all night and all day on the construction, and each hopes for a "christening" during Christmas week. The combined cost of the houses will be close to half a million dollars.

Both theatres are to house feature films. The Clemmer previously had announced that the Paramount corporation's products would make up its programs. This week Ye Liberty announced the signing of a contract for Alco service.

Ye Liberty has contracted for an orchestra-organ from the Wurlitzer Company. The Clemmer has ordered an organ from the Eilers house.

Einar Peterson, a young artist who did the interior paintings for the new million-dollar Davenport hotel, has been engaged to do a series of murals for the Clemmer, which is across the street from the hotel.

Plan Chain of Theatres In Northwest

SAM W. B. Cohn, manager of the Empress picture house and the New Spokane, Spokane, Wash., which uses both pictures and vaudeville, is associated with Eugene Levy of Seattle in a plan to establish a chain of film and variety houses from Spokane to the Coast.

Mr. Levy is announced to have completed negotiations for the purchase of the Cord Theatre at Pasco, and the Queen Theatre at Ellensburg. He already controls the Grand Opera House in Seattle, three theatres in Tacoma, and one in North Yakima. He has named Mr. Cohn as general manager of his houses, with headquarters in Spokane.

Mr. Cohn will assume his new duties December 1, and will be succeeded as resident manager of the New Spokane and the Empress by A. D. Myers.

Theatres Here and There

THE Bijou Dream, Buffalo, N. Y., which was recently taken over by the Tift estate, the original owners, has been redecorated and a new policy adopted. The management has put in the General Film service, and John Ross, a Buffalo artist, has been engaged to paint posters for the features. The admission price will remain at five cents.

The Globe Theatre at the corner of Main and Ferry streets, Buffalo, N. Y., is again under the control of the original owner, G. Morton Wolfe, architect of the Ellicott Square.

New Theatre In West Manhattan

Another moving picture theatre is planned for the west side of Manhattan as the result of a twenty-one years' lease just obtained by a syndicate headed by Lewis C. Van Riper from the Coe estate of the property at 2182 to 2186 Broadway, fronting 77 feet between Seventy-seventh and Seventy-eighth streets, New York City, with an extension to 227 to 231 West Seventy-seventh street, fronting 50 feet there.

A two-story building, which has been used as a market and a garage, occupies the plot, and it will be remodeled from plans by Thomas W. Lamb for the projected theatre. The aggregate lease for the term will be about \$350,000.

The Alpine Theatre, a moving picture house in Cortlandt street, Tarrytown, N. Y., was destroyed by fire recently. The loss is estimated at \$7,000. The cause of the fire is unknown.

A motion picture theatre with a seating capacity of 500 seats is being built by Lewis Ahlemp for G. H. Chapman, at Second street Pike and Loudon streets, Philadelphia, at a cost of \$7,000. The structure is to be 109x100 feet, of fireproof steel and concrete construction.

The old Danish Lutheran church at Troy, N. Y., is to be transformed into a moving picture house. Raymond Schoonmaker, of Castleton, who purchased the building for \$3,100, will begin remodeling the church within a few days.

J. A. Menard has sold the Majestic Theatre, business and building to A. J. Hendrickson, No. 37 West Colton avenue, Redlands, Cal. The consideration was \$22,500.

Mr. Menard received \$12,000 in cash, local property and Long Beach lots valued at \$10,500. The Majestic is one of the largest motion picture houses in the city, and one of the best businesses in that section.

New Wilmington Theatre Under Way

Work has been started on the motion picture theatre building to be erected at Nos. 810-12 French street, Wilmington, Del., for Dr. S. G. Elbert, at a cost of \$25,000. Plans for the structure were prepared by Eugene Wallace Hance, architect. The new building will be one of the handsomest structures of the kind in the city.

Many innovations just introduced into some of the largest theatre structures in New York and other cities will be included. Special attention has been paid by Mr. Hance to ventilation, seating arrangements, etc. The theatre will be completed in about five months.

Thompson, Hubman & Fisher have completed the handsome new building at the corner of Broad and Delaware streets, North Tonawanda, N. Y., which will be occupied as a moving picture theatre and bowling alleys. The building represents an outlay of \$30,000 irrespective of equipment.

Charles Hetrick is building on Spruce street, Cedarhurst, L. I., a theatre to be occupied by Arthur Silverman, a Far Rockaway moving picture exhibitor. The new theatre will be a modern building, fitted with stage and balcony. It will accommodate 500 people, and will be opened before New Year's Day, it is expected, and will be devoted to the movies.

Hyman Gereson has bought the Brunier hair factory property, 18-30 Garrison Lane, south of Baltimore street, in West Baltimore, Md. It is 120 by 350 feet, and contains several factory buildings and dwellings. Mr. Gereson will build a moving picture theatre, bowling alleys and dance hall on the site. The deal was made through the office of William Martien & Co.

Announcement is made that the title of the property on South Broadway and Prospect street, Yonkers, N. Y., the site of the new theatre now in the course of construction, has been transferred from the Edgar Allen M. S. Epstein company to the A. E. R. Corporation, of New York City.

The Western Ausement Company has taken over the old Swissh Opera House in Morgantown, W. Va. It has been remodeled and christened "The Strand." John P. Harris is managing director. This new theatre has signed for the Alco service.

Goldfinger & Berkowitz have been granted a permit by Fire Marshall Haynes to erect a moving picture house on Sixth avenue, north of Glen avenue, to cost \$5,000. Work on the building has been begun.

Village Offers Reduced Fee for Exhibitor

In an effort to have a moving picture theatre open in Falconer, N. Y., this winter the village board has just passed a resolution abolishing a license fee for such theatres. In 1911 the same board

Directory of New Theatres

passed a resolution charging \$500 license for picture shows. The next year it was reduced to \$50 and in 1913 the fee was brought down to \$25. Each year the theatre has had several different proprietors and each season it has closed down in the middle of the winter.

It has been suggested that next year the village board give a bonus to anyone with nerve enough to start the enterprise.

The remainder of the property on Jefferson and State streets, Perth Amboy, N. J., belonging to the McDonough estate has not been disposed of by Isaac Alpern, who is the trustee. This will probably be held through the winter and it is rumored that in the spring a moving picture theatre will be erected there. Jonathan Compton, of South Amboy, who is erecting a house at Melvira Park, on the South River road, has already sold it to Mrs. Louisa Price, and is contemplating the erection of another residence at that tract.

It is practically assured that the Keith vaudeville interests will have a new theatre in Grand Rapids, Mich., by next season. John J. Murdock, head of the Keith Circuit, has made several personal visits to Grand Rapids of late looking over various sites, and it is understood he has about closed for one. The Keith vaudeville is now playing at the Columbia Theatre, owned by Messrs. Gillingham and Smith. In the event that the Keith circuit has its own house, the Columbia, would, no doubt, go to high-class motion pictures.

Contracts have been let for the remodelling of the brick building at the corner of Woodward and Harper avenues, Detroit, Mich., which will be changed into a moving picture theatre to be known as the Harper. It will have a seating capacity of over 300.

Work is progressing unusually fast on the new Knickerbocker Theatre at Jefferson avenue, near the Belle Isle bridge approach, Detroit. The walls are up and the roof is now being put on. The owners plan to have it ready for occupancy not later than May 1, 1915. Adjoining the theatre will be a hall called "Hunting in the Ozarks" which will have booths selling various articles.

Rosedale Opening in Detroit Postponed

The new Rosedale Theatre opening in Detroit, Mich., has been postponed from Thanksgiving day (the date originally planned) to December 15. The seats have been ordered for December 10 and it is fully believed that the theatre will be completely finished and in readiness to open by the 15.

The Rosedale is located at 2395 Woodward avenue, and will seat 1,200 people; it will have a large foyer capable of holding at least several hundred people more. The Rosedale belongs to William F. Klatt, who now operates a chain of theatres in this city. His newest venture, the Jewell Theatre, at 448 Gratiot avenue, seating 600, formally opened November 14.

Offices have been opened at 2033 Dime Bank building, Detroit, Mich., by the Grand Boulevard Theatre Co., which plans to erect a large picture theatre on the Grand Boulevard, near Woodward avenue. The property has been purchased and the plans completed; all that remains now is for the money to be raised, when contracts will be let and the work rushed. The company has increased the capital stock from \$100,000 to \$150,000, and the stock will now be offered to the public. Fuller Claflin is the architect.

B. Harlan Starr, manager of the New Empire Theatre on Woodward avenue, Detroit, since the house opened, has resigned and has been succeeded by H. W. Smith, formerly assistant manager.

Pierre Lindout, architect in Grand Rapids, Mich., is preparing plans for a theatre to seat 450, to be devoted to pictures.

Looking Over Michigan Theatres

Robert G. Peltier, owner of the Bijou Theatre in Mt. Clemens, Mich., is erecting a new home at a cost of \$5,000. It will be 32 by 45 feet in size, 1½ stories high.

The Alladin Theatre in Bay City, Mich., opens November 30 with Ethel Barrymore in "The Nightingale." This is Bay City's newest picture house, and it is up-to-date and modern in every respect. The management has arranged for the use of the Alliance program.

The Kerridge Theatre in Hancock, Mich., Ray Kerridge, manager, has secured the exclusive rights for Hancock and Houghton to Paramount films. An admission price of 25 cents will be charged.

Capt. W. D. Ament has disposed of the Bently Grand Theatre on the Pike at Long Beach, Cal. to W. H. Kuhn and several associates. Mr. Kuhn will act as manager. Capt. Ament, who was formerly in vaudeville, is again appearing back of the footlights, and will soon depart for the east over one of the large circuits. The new manager of the Grand has made a contract with the Nat A. Magnar company of Los Angeles through local manager A. H. White for four days feature service weekly, including all the Alliance program releases.

Manager A. H. Reeves, of the Auditorium theatre, San Bernardino, Cal., will hereafter show Alliance program features three days of each week.

Bernstein & Shepherd, proprietors of the Capitol and Casino theatres in Springfield, Ill., are to open another theatre in that city. The new motion picture house is being erected at Eleventh street and South Grand avenue by J. J. Scanlan, who has leased it to Bernstein & Shepherd. The new theatre is to be of brick and concrete and will be thoroughly modern in every respect. It will cost complete, approximately \$8,000.

Buys Turner & Dahnken Theatre

The Berkeley Theatre, conducted for the past four years at Berkeley, Cal., by Turner & Dahnken, who conduct a circuit of seven houses in the San Francisco territory, has been disposed of to C. A. Reavis, who is to assume the management before the end of November. Turner & Dahnken are just completing the construction of a new house in this city with a seating capacity of about 2,000 and will open this early in December, the opening attraction to be "Neptune's Daughter," according to present plans of the house. A. H. Moore is now the resident manager of this firm, having succeeded E. V. Clover.

Active construction work has been commenced on the new moving picture house to be opened in the Spring at Eddy and Fillmore streets, San Francisco, Cal., by the Kahn & Greenfield Circuit. It is planned to have this ready for occupancy about the time of the opening of the Panama-Pacific International Exposition.

Boston Theatre Installs Austin Organ

A \$25,000 Austin organ has been installed in the New Park Theatre, Boston, scheduled for opening December 1. Special arrangements have been made to supply the theatre with an orchestra which will render the best music in an efficient manner.

The theatre will be devoted exclusively to the Paramount program.

W. E. Greene, Moe Mark and several other associates operate the Park Theatre Company.

One hundred thousand dollars was spent in renovating and remodeling the theatre. The old gallery was taken out and supplanted by a modern balcony. It has every convenience, even to the filtration of the air.

When it is remembered that Boston is the individual and sole mecca for all of New England, and that most of its advantages and individual interests and social customs emanate in the Hub, the fact of such a house running Paramount features will be apparent.

Music and the Picture

Editor's Note.—This department is prepared to answer all questions from exhibitors relating to the use of music in connection with photoplays, and to suggest suitable music for current pictures. Correspondence will be welcomed

Fitting the Words of a Song to the Picture

By H. S. FULD

FROM time to time we have advocated in these columns the use of popular songs and melodies for the pictures wherever they might, in the judgment of the player, fit the scene on the screen. And yet while the suggestion still stands, it seems there are times when it is overdone. Witness the following letter from a player at one of the better class of motion-picture theatres:

"I am enclosing a letter I received at the theatre from a friend of mine that is self-explanatory. You may use it any way you want, but please give me your idea on it." The letter follows:

"Your playing pleases in the main, and you follow the pictures, and the audience is very much pleased with that part of it. The part that the patrons and the management of the house do not like is where you "kid" a dramatic picture."

"Another criticism is that you do not play recent tunes. As far as I remember, this has always been one of your faults. And you go back too far for your old tunes."

A dramatic picture must be played straight drama, otherwise, if you try to "kid" and play tunes with a suggestive meaning, or tunes to convey a meaning other than the action calls for, it detracts from the story or action on the screen.

While you no doubt deserve the first criticism, and probably "killed" a scene by kidding it—maybe you played "It Looks To Me Like a Big Night To-night" when a couple were getting married, or something equally suggestive—nevertheless the last one about old songs I do not agree with your friend.

No matter how old a song or melody, if you know it and it fits the picture, play it. There are in all probability others in the audience who will recognize it.

For instance, the old songs "She Was Happy 'Til She Met You," "Bird in a Gilded Cage," "Hello, Central, Give Me Heaven," "Alice, Where Art Thou," and so on, are still known by the present generation, and if fitted to their proper place for the scenes calling for the particular words in a particular song, nothing would be more in place than the playing of that song or melody.

Take the words of "In the gloaming, Best for you and best for me that we should part." 'Tis old, but what is more fitting for a parting scene than it, or "Oh, my darling, Nelly Grey, they have taken you away, and I'll never see my darling any more"?

As long as the words fit the situation or action on the screen, use the song of those words, no matter how old the tune. But in a serious drama, if an old woman puts on an outlandish hat, don't play "Where Did You Get that Hat," even though the words do fit. In such a place "kidding" is out of place, and it was no doubt some such "faux pas" that brought you that criticism in the first place.

While on this subject it might not be amiss to state that another party writing for the same department page on one of our numerous contemporaries, agrees with us, in that "playing a lot of classic stuff regardless of its fitness may please the music lovers, but it does not help the show as a whole." Stick to the popular and catchy numbers and save your overtures for before shows, between shows, educational films, or exit marches.

"Piano-Orchestrions" versus Orchestras

FROM time to time in these columns we have had occasion to refer to the accompaniment of pictures in various ways: piano, or piano with drums, full orchestra, Photo-player, and Orchestrions, such as the Wurlitzer. We have frequently expressed the opinion that one of the best ways to find arguments in favor of these Orchestrions, or piano-orchestras as they are

most commonly termed, is for a person to visit one of the numerous theatres where one is being used and played by a fairly capable performer and hear it accompany the pictures.

The gradual perfection of these instruments has made it possible for one person to supplant an entire orchestra, and not only obtain the same results, and retain the same advantages, but have the additional advantages in the shape of organ tones, Vox-Humana and so on, that would be impossible for an orchestra to render.

It seems to us that the logical solution of the problem of proper musical accompaniment for the pictures, lies with one of these instruments under the immediate control of one person, and that person a competent piano player.

In the hands of a competent player we listen to the music, and it is not so obtrusive as to destroy the musical effect, because the music is so blended with the action of the picture as to make a most desirable combination. The entire musical accompaniment is directed and controlled by this one performer on the instrument, and the atmosphere required in a musical sense to improve the picture is never lacking.

With an orchestra it is only possible to play selections, and on most occasions these selections are rendered so creditably as to detract the audience from the picture in favor of the music, and close attention to the photo play is out of the question.

Of course, it is hardly possible for an orchestra to follow a picture closely, though in a few instances where a theatre runs a picture for a week there is ample time to arrange a program that will fit the picture. And this is the exception rather than the rule. One would be hard put to rehearse an orchestra every day so that the proper music be selected so that the picture could be followed closely.

Where there is a sudden and extreme change of treatment in the picture, an orchestra could hardly make the quick change to follow this action, consequently, the selection being played would be entirely unsuited for this particular part of the photo play. And right here is where the great advantages of the Orchestrion comes in. Whether it is a sentimental scene in a heavy drama suddenly changing to comedy, or a humorous situation suddenly becoming serious the music changes on the instant, to suit that particular scene.

The different instruments that go to make up the Orchestrion, violin, flute, horn, cello, bass, clarinet, chimes, are all at the command of the one operator either singly for solo, or in groups, or in entirety. Also kettle, bass, and snare drums, bells, whistles, auto-horn, fire or locomotive bell, tambourine, and so on, in fact almost any sound effect called for by the action on the screen is immediately available.

An overture played on one of these instruments, whether it be operatic or only a popular melody that is being rendered, is always a treat to a music loving audience.

Well Known Singers Accompany Montreal Pictures

FOR the first time in Canada there is being shown at the Tivoli, Montreal, motion-picture songs. Mr. English, manager of the house, who is always to the fore in securing the latest successes for his theatre, engaged one of Montreal's leading vocalists to sing in conjunction with the pictures.

The attraction has drawn some record houses, and the opinion was generally expressed that the whole effect was very charming, and as great an improvement on the old stationary slide pictures as the present-day feature compares with the old-time flickering one-reeler.

Perfumes and Disinfectants

THE use of either one or both as air deodorizers has become almost universal. It is estimated that 90 per cent. of the motion-picture theatres in the country are users of perfumes and disinfectants. For example, in St. Louis, 97 per cent. of the houses are said to be constant consumers. The amount spent by each theatre averages from \$50 to \$200 each year, the average being about \$75. It is interesting to note that throughout the South and West a higher class of goods are being used than in the East, where quantity and not quality seems to figure.

The various forms of disinfectant contain a certain amount of formaldehyde, together with the essence of the perfume desired, as well as a percentage of menthol. This is distributed ordinarily by means of a sprayer of one quarter capacity.

This scatters the disinfectant in the finest kind of spray which reaches every corner of the house when applied. The life of one load of the sprayer is, under ordinary circumstances, four days; for, by continuous pumping, it takes more than two hours to empty a full load. The odor of the high-class disinfectant is refreshing and always pleasing.

In some states, the authorities absolutely compel theatre owners to use disinfectants regularly, and in several of the mining districts, the local authorities take matters in their own hands and see that the disinfectant is used in all public gathering places, which, of course, include the picture houses.

The perfumes, which are in no way disinfectants, are applied by several methods, cone sprayers or electric fans being the most popular. The cones, which are made of a porous material and are hung up about the theatres, are filled with the perfume, which is allowed to evaporate. From six to eight compose a complete equipment for a 300-seat house. In order to make these receptacles attractive aside from their neat designs, artificial flowers are often decorated over them so that they resemble a jardiniere, and rather than being an eye-sore are a decided attraction to the house.

For example, wistaria can be draped from a cone which is filled with the wistaria perfume. This may be also applied to lilac and various other flowers. In the summer, when fans are used, sponges or other porous material which are saturated with perfume are fastened in front of the fan, thus distributing it throughout the house.

In the case of perfumes, they are composed of a portion of alcohol which forms the evaporating substance, together with the essence of the perfume which is desired. There is one use to which perfumes can be put which is not universally known. This is in dispelling and neutralizing tobacco smoke, and in all houses where smoking is allowed, perfume should be used abundantly in order to keep the fumes from becoming objectionable.

PAULIS GENERAL MANAGER OF COAST CAMERA FIRM

H. PAULIS, for several years with the camera firm of Keufel & Esser, New York City, and since connected with the Adolph Freese company in this city, is the new general manager of the Los Angeles Motion Picture Company, manufacturers of Angelus motion picture cameras, tripods and other equipment for camera-men. The company is weekly increasing the output of their factory to meet the demands of the trade and in addition to many orders from professional camera-men and exhibitors in America, are making many foreign shipments.

Carl Sternlov, formerly manager, found himself too busy in the management of a studio and a 120-acre orange ranch, to superintend the factory, and is now connected with the sales department only.

THEATRE BUYS GIANT MIRROROIDE SCREEN

THE Regent Theatre at Paterson, N. J., has just installed the largest screen in any theatre in the state of New Jersey. The screen is "Mirroroide," made by J. H. Genter Co., and is 17 feet and 8 inches high by 22 feet and 6 inches wide. This screen replaces the one destroyed by a slight fire in the theatre last week, and was sold by Mr. Morrell, of the Genter Co.

SAFARI IS SHOWN IN BROOKLYN

"SAFARI," J. C. Hemment's latest African pictures, was shown at Kismet Temple, Brooklyn, N. Y., on Saturday, November 7. The pictures, which were taken with an "Eclair-Gillon" camera, were enthusiastically received by a large and appreciative audience.

Our Electrical Holly Wreaths

EXTEND THE REAL CHRISTMAS GREETINGS TO YOUR PATRONS

A CHRISTMAS HOLLY WREATH that is full of life and beauty.

\$6.00 Each

These Wreaths are made of rich CHRISTMAS GREEN FIREPROOFED holly leaves, studded with (8) Red 14 volt one candle power miniature lamps.

18 inches in Diameter.

Bright Red Holly Berries showered among the leaves, giving it the CHRISTMAS ATMOSPHERE.

Can be attached to any receptacle.

For the front of the BOX OFFICE.

One on each side of the Screen.

Along the walls of your Theatre.

Get your order in early.

Manufactured by

The Schroeder Art Flower Mfg. Co.
6023 Superior St., Cleveland, O.

Make Your Lobby Display Attractive

There is nothing more fascinating to the public than a bright brass frame to display your photos or posters.

We make Lobby and Theatre Fixtures and Brass Rails of every description.

Don't fail to visit our Showrooms. Write for catalog.

THE NEWMAN MFG. CO.
717 Sycamore St., Cincinnati, Ohio
Branch Factories and Show Rooms:
101 Fourth Ave., New York, N. Y.
106-108 W. Lake St., Chicago, Ill.
Established 1882.

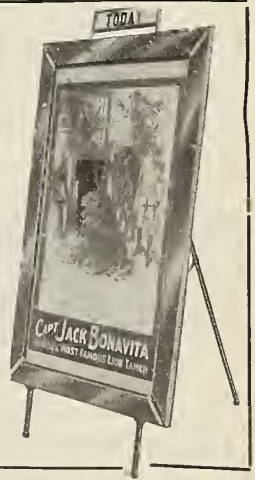

MOVING PICTURE THEATRE MAILING LISTS FOR SALE

20,192, covering United States and Canada, Price \$40.00, or \$3.50 per thousand for such states as you want.

- 795 Film Exchanges, U. S. \$3.50
- 70 Manufacturers and Studios, U. S. 1.00
- 34 Moving Picture Machine Mfrs. and Dealers.... 1.00
- 231 Film Exchanges, Foreign Countries..... 3.00
- 520 Moving Picture Theatres, Foreign Countries.... 3.00

Ask us for full particulars.

TRADE CIRCULAR ADDRESSING CO.

166 West Adams Street, Chicago
Established 1880

The Theatre as a Social Centre

(Continued from page 111)

smaller town, would be ideally constructed for carrying out the club plan.

The Globe is a tribute to the skill of the designer. The building is of brick, with concrete for the foundation walls, having cement for the exterior put on over the brick. Staff composition is used for the ornamental work on the front. The ball room extends the length and breadth of the building, which is fifty by one hundred feet. The ball-room has all modern conveniences such as cloak rooms, and toilets for men and women. There is a handsome music platform at the end of the ball-room.

The main entrance lobby to the theatre has tile floor and marble wainscoting all around the sides, including the box office. There is plate glass in the entrance doors and the front of the box office.

The stairs leading up to the ball-room are located at the left of the main entrance, and at the right is a small cigar store.

The building has proved exceedingly popular on account of the bowling alley in the basement, the theatre on the main floor and the ball-room over the theatre. It is packed nightly from top to bottom and brings the owner an income of \$95 for the basement, \$325 for the theatre, \$125 for the lodge rooms, a total of \$545 per month.

The building complete without the opera chairs, carpets, curtains and draperies and stage scenery and the apparatus in the operating booth, cost \$30,000. The ground is valued at another thirty thousand, making a total investment of \$60,000. The owner receives a little over ten per cent. on the investment as rent.

The theatre and ball-room and the basement are ventilated by means of two intake and two exhaust electric fans, supplying the proper amount of fresh air, and exhausting the foul air at all times.

The operating room is equipped with two Powers 6-A projection machines, one dissolving stereoptican, one spot light, and a mercury arc rectifier.

There has been installed an indirect lighting system, consisting of six staff bowls containing three 100 watt tungstan lamps with X-ray reflectors on three circuits, so that it is possible to have at will one, two, or all three lights. The ceiling lights as well as the foot and the border lights are all controlled from the operating room, and also from the switchboard from the lobby.

The entire front of the building is outlined and illuminated with electric lights. The lamps are arranged on circuits so that any part can be extinguished at will.

The total seating capacity is 480, including 88 loge seats, surrounded by a brass rail. Ceiling and side walls are decorated with hand-painted emblems. There are neat stencil borders in the ceiling panels. All the ornaments of the staff work are high-lighted with gold leaf.

MOTION PICTURES PART OF CAFE CABARET

CAPT. JAMES CHURCHILL, who owns and operates one of the largest restaurants in New York, has instituted something brand new in the entertainment line to augment the regular evening cabaret entertainment offered.

On Monday night, November 16, Mr. Churchill began showing pictures for the benefit of his patrons, who had begun, so it was reported, to lose interest in the dancing. Capt. Churchill has fitted up his hall with a Johns-Manville booth, a Powers 6-A machine and a day and night screen, which last enables him to run his pictures while the lights are still on. Universal service is being shown, with special emphasis placed on the comedy end of the program.

NEWMAN PUTS LACQUER ON THE MARKET

THE Newman Manufacturing Company has just put a new preparation on the market known as lacquer. This is a transparent liquid which when applied to metal surface is guaranteed to prevent tarnishing.

It not only keeps and preserves the metal, but insures the luster for years. A pint will cover ten one-sheet brass frames.

PERFECT DEVELOPING AND PRINTING

For Amateurs and Professionals in any Quantities.
WE GUARANTEE QUALITY PLUS PROMPT DELIVERY AND PERSONAL SERVICE.
Prices, References and Factory Description Sent at Your Request
INDUSTRIAL MOVING PICTURE COMPANY
223-233 West Erie Street, Chicago

Be sure to mention "ACCESSORY NEWS" when writing to advertisers.

Xmas Slides

Write for Catalog

Novelty Slide Co.
 67 West 23d St. New York

WANTED SCENARIOS

One Reel Comedies
 Three Reel Dramas

ESPERANTO FILM MFG. CO.
 216-222 Monroe Avenue, DETROIT

FURNITURE & FURNISHINGS

On RENTAL

We equip your settings complete in accordance with your scenario.

WILLIAM BIRNS
 103-105 West 37th St.
 Phone: Greeley 6255.

Your negative developed, printed and titled complete
5c delivered per foot within **12** hours

Titles **6c** per foot

GUNBY BROS., Inc.
 145 West 45th Street New York City

ROLL TICKETS Specially Printed and Absolutely Guaranteed

Cash with order. No C.O.D. at these prices.
 50,000 for \$5.40 200,000 for \$15.30
 30,000 for 4.50 100,000 for 9.00
 Write for Samples and Prices on Other Quantities.

Rees Ticket Co., 400 So. 10th St., Omaha, Neb.

PLAYER SLIDES

Just what you need, the best made, \$1.75 per dozen. Say Who. There is only one place to get them and that's from the **NIAGARA SLIDE CO.**, Lockport, N. Y.

SLIDES

OF ALL DESCRIPTIONS
Excelsior Illustrating Co.
 219 6th Avenue, New York City
 Tel. 7760-7761 Chelsea

LE COURRIER

Cinematographique

28 Boulevard St. Denis, Paris

Directeur: Charles LE FRAPER

Journal hebdomadaire français, le plus important de l'industrie cinematographique.

Envoie numéro spécimen, sur demande.

CLASSIFIED

FILMS

FOR SALE—A few exceptionally strong features, wonderful photography, two, three and four reels. American and Canadian rights. Reasonable offers considered but no sacrifices. G., care Motion Picture News.

THIS CANNOT POSSIBLY MEAN ANYTHING TO YOU

If you are not a Live Wire Exhibitor

BECAUSE ACCESSORY NEWS IS BUILT FOR LIVE WIRES ONLY

Read It and See Why

For goodness sake
Use Clean Posters

Using raggedy, torn, dirty posters is like putting on a torn dirty shirt on a fine Sunshiny Sunday Morning to go to Church. A clean front betokens a clean inside, clean shows and clean management, and this poster question is one of supreme importance to every Exhibitor's Success.

You can trace the tremendous success of the big circuses like Ringling Bros.—and all the other big shows to the tremendous pulling power of Posters. You may not be Ringling Bros., but you are not asked to advertise on this scale, BUT you are asked, advised and urged to use posters on the scale you can afford.

If you will pick out the proper spots in your town and use Universal Posters liberally,—put up artistically, clean and in good shape, these stands will work for you day and night. A powerful poster in a good live spot will bring greater results than a lot of cheap heralds thrown around promiscuously by incompetent distributors.

We have spent and are spending fortunes each year on posters. We don't know what expense means when it comes to getting out the wonder stuff in this line. If you will use your brains and co-operate with us, following our suggestions about putting up CLEAN POSTERS in clean places the results will amaze you. Write your Exchange, or if you can't get quick action, write or wire

THE MORGAN LITHOGRAPH CO., CLEVELAND, OHIO.

Write or Wire Your Exchange First

DECEMBER 12, 1914

Motion Picture News

HAS THE QUALITY CIRCULATION OF THE TRADE

PARAMOUNT PICTURES

JESSE L. LASKY
PRESENTS



H. B. WARNER IN **THE GHOST BREAKER**



*PLAYING HIS ORIGINAL ROLE IN
THE PICTURIZATION OF THIS THRILLING BROADWAY SUCCESS
BY PAUL DICKEY & CHARLES W. GODDARD*

RELEASED DECEMBER 7TH

JESSE L. LASKY FEATURE PLAY CO.

LONG ACRE THEATRE W. 48TH STREET N. Y. C.

JESSE L. LASKY SAMUEL GOLDFISH CECIL B. DeMILLE
PRESIDENT TREAS & GEN. MANAGER DIRECTOR GENERAL



ROBERT LEONARD AND ELLA HALL
IN



THE MASTER KEY

by JOHN FLEMING WILSON

*A Thrilling Story of
Mystery and Romance!*

FIFTEEN
MOVING
WEEKS

UNIVERSAL

PICTURES

THIRTY
REELS

MOVING

UNIVERSAL

PICTURE



DANIEL FROHMAN
PRESENTS
THE FASCINATING, IRRESISTIBLE
MARGUERITE CLARK
IN
"THE CRUCIBLE"

By
MARK LEE LUTHER

IN
FIVE
PARTS



The stirring portrayal of an agonized
soul's triumph, through suffering, over
threatening evils.

RELEASED DECEMBER 21ST.

Produced by the

FAMOUS PLAYERS FILM CO

ADOLPH ZUKOR, President,

DANIEL FROHMAN, Managing Director EDWIN S. PORTER, Technical Director

Executive Offices,

213-229 W. 26TH STREET, NEW YORK.



PROVED SUCCESSES



"Home, Sweet Home"

GRIFFITH'S

HOME SWEET HOME

(Six Reels)

FOR THE HOLIDAYS

BOOK IT NOW

AN IDYL—A SERMON—AN ABSORBING DRAMA
is showing in more theatres to more money than any motion
picture ever produced.

THE MOUNTAIN RAT

(Four Reel)

A tense, vital drama of Western Life.—A house-filler.

GRIFFITH'S

The BATTLE of the SEXES

in five reels. The vital material would have made eight but
that isn't Griffith's way. Greatest story of the Double Moral
Standard ever produced or written. It jams theatres.

BOOK IT!

THE WRATH OF THE GODS

SIX SMASHING, THRILLING REELS OF CONCENTRATED
DRAMA PRODUCED BY

THOS. H. INCE

Japanese Story, Japanese Actors, Volcano in Eruption! Filling theatres. It fattens your box office—book it now.



All Mutual
Exchanges

CONTINENTAL FEATURE
29 UNION SQUARE,

FOR CASH PROFITS

BOOK

THE GREAT LEAP

MAE MARSH and ROBERT HARRON are the stars; four reels is the length and intense drama wonderfully well presented is the big claim to your attention. The finish is smashing drama. Book it now.

GANGSTERS

(Four Reels)

Long run at Weber's Theatre, New York. "A great lesson to all."—New York American.

Big Day Specials

RUY BLAS
THE FLOOR ABOVE
FROU FROU
JOSEPH IN THE
LAND OF EGYPT
CARDINAL RICH-
ELIEU'S WARD

DOPE
SAPHO
ZU ZU
MOTHS
LEGEND OF
PROVENCE

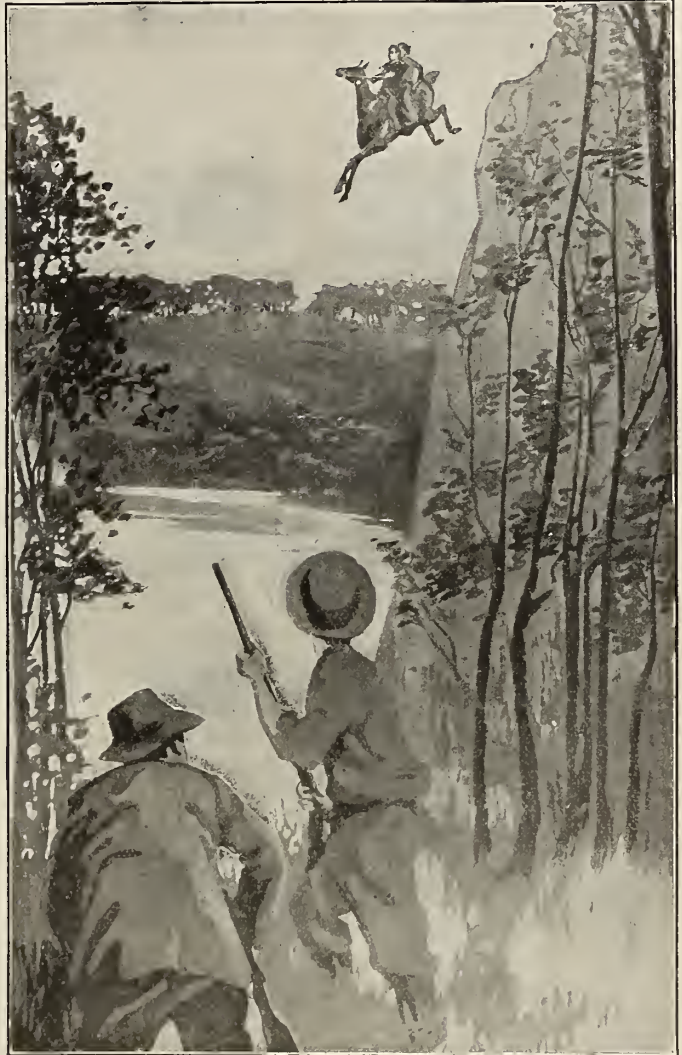

Scene from "The Great Leap"

**FOR A WAR
FEATURE DAY
SHOW ONE
OF THESE BIG
SUCCESSSES**

MEXICAN WAR PICTURES
By Special Contract with General Villa
THE DISHONORED MEDAL
With French troops in action
BATTLE OF GETTYSBURG
Greatest War Feature Ever Produced

FILM CORPORATION
NEW YORK CITY

*All Mutual
Exchanges*





THE MUTUAL PROGRAM

Special Two-part feature

SUNDAY, DEC. 13

There is a remarkable double characterization in the poetic picture story

THE OLD MAID

A production that should prove itself an artistic creation of exceptional merit, suggested in part by the beautiful poem "DOROTHY IN THE GARRET" by JOHN TOWNSEND TROWBRIDGE. In the cast **BLANCHE SWEET**, **MARY ALDEN**, **SPOTTISWOODE AITKEN** and **JACK CONWAY**.

THE MAJESTIC AND KOMIC GUIDE FOR EXHIBITORS

(In which we try to tell only the truth about all Majestic and Komic releases)

- THE OLD GOOD-FOR-NOTHING.** (1 Reel Majestic.) Release date Tuesday, Dec. 1. A delightful character comedy drama in which Spottiswoode Aitken plays the part of the lovable old inventor who is thought to be "good-for-nothing," but who finally wins out gloriously.
- A QUESTION OF COURAGE.** (2 Reel Majestic.) Release date Sunday, Dec. 6. A strong, virile picture-drama, reasonably well produced, telling the story of a mother who bravely gave two sons to the war but rebelled when it came to losing the third son.
- MR. HADLEY'S UNCLE.** (1 Reel Komic.) Release date Sunday, Dec. 6. This is No. 12 of the famous "Bill" stories by Paul West, published in 20 Sunday newspapers in the larger cities. It is an excellent number.
- HER BRAVE HERO.** (1 Reel Majestic.) Release date Tuesday, Dec. 8. A fair farce comedy, but not quite up to standard. Hubby becomes a hero under false pretences.
- IN WILDMAN'S LAND.** (1 Reel Majestic.) Release date Friday, Dec. 11. A comedy drama quite out of the ordinary, cleverly produced and acted, telling a weird story of a strange tribe of wild people.
- THE OLD MAID.** (2 Reel Majestic.) Release date Sunday, Dec. 13. An unusual, artistic offering, especially recommended for the higher class houses, featuring Blanche Sweet. The "Old Maid" recalls the story of the youth.
- THE HOUSEBREAKERS.** (1 Reel Komic.) Release date Sunday, Dec. 13. Above the average Komic. Eddie Dillon as the timid sweetheart proves his courage.

MAJESTIC MOTION PICTURE COMPANY

Studios: 4500 Sunset Blvd.
Los Angeles, Calif.

Business Offices, 29 Union Sq. W.
New York City.



ABOVE ALL QUALITY

MUTUAL PROGRAM

KAY-BEE
FRIDAY DEC. 11TH
 Features of WAR

KEYSTONE
MONDAY DEC. 7TH
 The Pelican's Nest

BRONCHO
WED. DEC. 9TH
 The City of Darkness

DOMINO
THURSDAY DEC. 10TH
 No. 9 of the Flock

Released Exclusively Through the MUTUAL FILM CORPORATION

At The Front

Photos of our Players can be had by sending to Publicity Dept. 15 cents for one 50 cents for set of four.

22x28 Photo Layouts in character make-up of Mable Normand, Chas. Chaplin, and Roscoe Arbuckle. 20 cents each

GREAT BRANDS OF FILM
 KAY-BEE KEYSTONE
 DOMINO BRONCHO

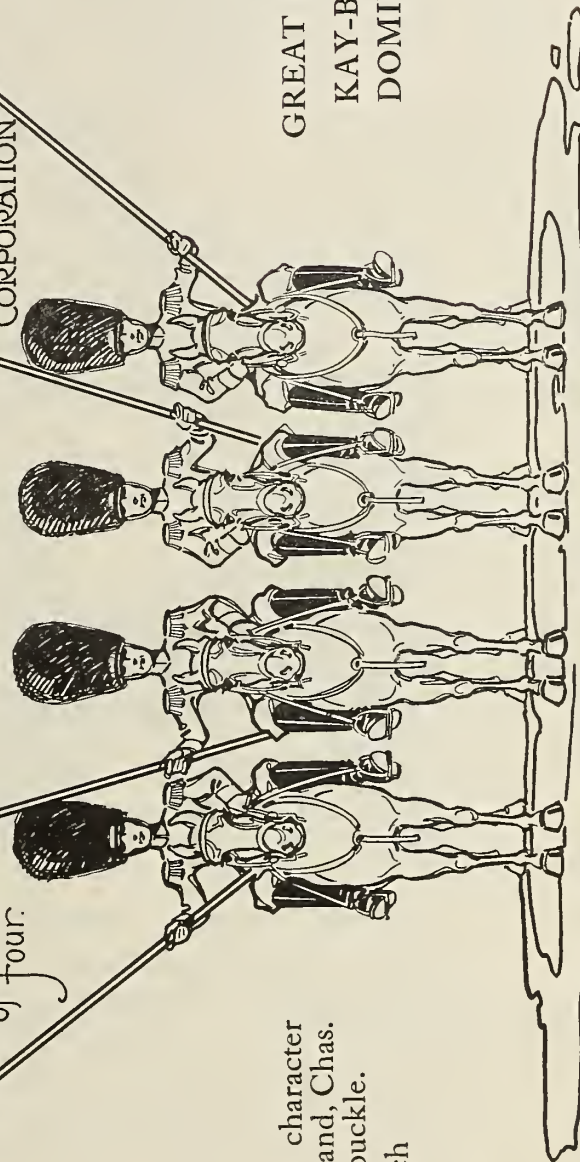

NEW YORK MOTION PICTURE CORPORATION

LONGACRE BUILDING 42^d Str. and BROADWAY
 NEW YORK

Thanhouser Photoplays

FIRST in Stars!
FIRST in Settings!
FIRST in Photography!

—and Now—*FIRST in the
 Minds of the Movie Fans!*

STARS such as Florence La Badie, Sidney Bracy, James Cruze, Marguerite Snow, Harry Benham, Muriel Ostriche, Morris Foster, Mignon Anderson, Arthur Ashley, Helen Badgley, The Thanhouser Twins—and a score of others—are found in Thanhouser casts. No other motion picture producer can boast of such a group of stars! Thanhouser is **FIRST** in Stars!

Settings composed of the beautiful natural scenery near New Rochelle and a property equipment for interiors that knows no rival for artistic and distinctive effects. Thanhouser is **FIRST** in Settings!

Photography that is sharp and clear—the kind that makes an audience think of the master minds that evolved it—the kind that exhibitors the world over have pronounced *exceptional*. Thanhouser is **FIRST** in Photography!

—And *now*—because of its all-star company—because of its wonderful settings—because of its remarkable photography—because of such successes like *The Million Dollar Mystery* and *Zudora*—Thanhouser is **FIRST** in the minds of all movie fans.

You'll find all these Thanhouser advantages in the regular releases of the Thanhouser Film Corporation. Three new photoplays are released each week exclusively through the Mutual Film Corporation in the United States and Canada. Demand Thanhouser productions. The name alone guarantees **PACKED HOUSES**.

For the current week we announce:

Sunday, Dec. 13th. "When East Meets West." A drama enacted in beautiful Yellowstone Park. The cast includes Mignon Anderson and Morris Foster.

Tuesday, Dec. 5th. "The Barrier of Flames" (2 reels). This wonderful drama portrays the great devotion of a young child for her "shep." Cleverly acted by Morgan Jones, Helen Badgley, Carey L. Hastings.

Thanhouser Film Corporation
 New Rochelle, New York



SEE AMERICANS FIRST
 Flying "A" and American "Beauty" Feature Films
MADE IN U.S.A.

IN TUNE

RELEASE, DEC. 14, 1914



A Portrayal
 of Causes
 Underlying Fire-
 side Tragedies
 In Two Acts



Direction of
 Henry Otto.
Featuring
 Winifred Greenwood
 and Ed. Coxen

GORGEOUS

ARTISTIC

AMERICAN BEAUTY FILMS

"HER YOUNGER SISTER"

A Love Drama with a Touching Heart Interest Direction of Frank Cooley
 Release Tuesday, December 15th, 1914

FLYING "A" HITS OF THE WEEK

"THE SILENT WAY"

An adept presentation of life under the canopy of a blue sky. Release Wed., Dec. 16th, 1914.

"TRAPPED BY HELIOGRAPH"

A timely production of a soldier's joys and tribulations. Release Fri., Dec. 18th, 1914.



AMERICAN FILM MFG. CO.
 CHICAGO

RUNAWAY JUNE

Runaway June has the most daring and original plot ever seen on the screen. It thrills from title to tale-piece.

Runaway June is not a serial but a *serial series*. Each installment is a complete story dealing with the most vital problem of life.



GEORGE RANDOLPH CHESTER

Every leading paper in the United States and Canada will carry the story of Runaway June.

George Randolph Chester and Lillian Chester are the authors of Runaway June. It is their best work.

Money—the great God gold is the fundamental plot on which the action of Runaway June depends—it is responsible for all the situations in the story.

This great serial series will be released in January —if you are a live exhibitor, no matter what program you are using, you will



LILLIAN CHESTER

BY

GEORGE RANDOLPH CHESTER

— AND —

LILLIAN CHESTER

The most wonderful cast ever seen in pictures will appear in Runaway June. Over sixty members are in the Stock Company.

The action in Runaway June is unique in many ways. The picture and series do not depend on one star but the whole company act big live heart interest parts.

WRITE - WIRE - PHONE
RELIANCE MOTION PICTURE CO.
29 UNION SQUARE, NEW YORK CITY.



World Film Corporation

LEWIS J. SELZNICK, Vice-Pres. and General Manager

Announce their Appointment as
Sole Distributors of the Distinctive
Feature Productions of

the

CALIFORNIA MOTION PICTURE CO.

BEATRIZ MICHELENA

in

"MRS. WIGGS of the CABBAGE PATCH"

The famous Liebler Stage Success

Released January 4th

and

"MIGNON"

After the great opera with
the same star

Released January 18

In Preparation

"LILY OF POVERTY FLATS"

By Bret Harte

Dramatized by Marion Russell

In Preparation

"SALVATION NELL"

By Edward Sheldon

"THE PRICE SHE PAID"

By David Graham Phillips

WORLD FILM CORPORATION, LEWIS J. SELZNICK,
Vice-Pres.

Home Office, 130 W. 46th St., N. Y.

BRANCHES EVERYWHERE

BRANCHES EVERYWHERE

THE PRICE HE PAID

A powerful picture of the world-famous poem by
Ella Wheeler Wilcox



This vital, vivid and vigorous production holds its audiences spell-bound from beginning to end. And it also teaches a tremendous lesson of vast importance. Book it now.

UNITED FILM SERVICE (WARNERS FEATURES INC) N.Y.



PATHE

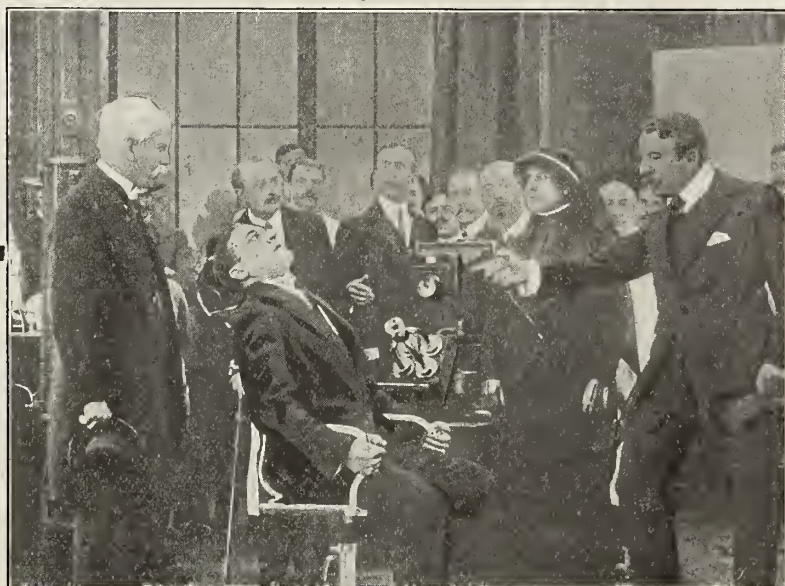

The Silent Accuser

2-part Pathé drama. The adventures of an inventor with his telephone that enables the user to see the person he is talking to. It is stolen from him, but by its use he brings the criminal to justice, and saves the girl he loves. Powerfully dramatic. 1-3-6-sheet posters.

The Quality of Mercy

2-part Pathé drama. A man is shot by the father of the girl he loves, but forgiveness proves to be profitable as well as noble. A strong, red-blooded play.

The Runaway Leopard

A Pathé animal comedy—one of the funniest ever—and run on the same reel with SOME NON-POISONOUS SNAKES, an unusual educational in natural colors.

A Temperamental Whiffles

Pathé comedy in 2 parts. Whiffles finds that some mothers-in-law are impossible and learns how to get rid of them. 1-sheet posters.

ASK ABOUT the prices on the magnificent 7-part production in superb coloring—THE LIFE OF OUR SAVIOR—1/2-1-3-8, and 24-sheet posters.

The Perils of Pauline

There's one sure bet in the world that is sure, and that's Pauline. She never fails to draw the crowds wherever she goes. PAULINE WILL START YOUR BANK ACCOUNT.

Exchanges in all the important cities of the United States

THE ECLECTIC
110 W. 40th Street



FILM COMPANY
New York City

"The Cream of American and European Studios"

Be sure to mention "MOTION PICTURE NEWS" when writing to advertisers.

Paramount Magazine

is a High Grade Magazine containing matter of universal interest.

It will present articles written by prominent artists in theatrical and motion picture circles, with photographs of the authors.

Copies of PARAMOUNT MAGAZINE may be given away as souvenirs at performances in Paramount Theatres beginning with an edition for Christmas.

Are you one of the exhibitors who will benefit by this plan?

If not, write our nearest exchange for information.



Paramount Pictures Corporation
ONE HUNDRED and TEN WEST FORTIETH STREET
NEW YORK, N. Y.



SPECIAL FEATURES

General Film Company

TITLE	MAKE	No. of Reels	TITLE	MAKE	No. of Reels
THIRD DEGREE	Lubin	5	MAN'S ENEMY	K. & E. Biograph	3
THOR, LORD OF JUNGLE.....	Selig	3	IN TUNE WITH THE WILD.....	Selig	3
THE BATTLE OF SHILOH.....	Lubin	4	THE WOLF	Lubin	6
THE LION AND THE MOUSE.....	Lubin	6	SHADOWS OF THE PAST.....	Vitagraph	3
THROUGH FIRE TO FORTUNE.....	Lubin	5	MR. BINGLES' MELODRAMA.....	Vitagraph	3
JUDITH OF BETHULIA.....	Biograph	4	MEN AND WOMEN.....	K. & E. Biograph	3
GERMINAL	Pathe	5	THE SECRET OF THE RING.....	Kleine	3
LOST IN MID OCEAN.....	Vitagraph	3	MY FRIEND FROM INDIA.....	Edison	3
A ROMANY SPY.....	Pathe	3	LIBERTY BELLES	K. & E. Biograph	3
A CELEBRATED CASE.....	Kalem	4	THE ERRING	Lubin	3
THE FULFILLMENT	Essanay	3	AMBUSHED	Essanay	3
NIGHT RIDERS OF PETERSHAM.....	Vitagraph	3	SONG OF THE SOUL.....	Kleine	3
HARDING'S HERITAGE	Pathe	3	KIT, THE ARKANSAS TRAVELER.....	Kalem	3
DAUGHTERS OF MEN.....	Lubin	5	CHIP OF THE FLYING "U".....	Selig	3
THE OTHER HALF OF THE NOTE.....	Kalem	3	FAIR REBEL	K. & E. Biograph	3
HER LADYSHIP	Selig	3	HOUSE NEXT DOOR.....	Lubin	5
GOODNESS GRACIOUS	Vitagraph	3	MY OFFICIAL WIFE.....	Vitagraph	5
OFFICER JIM	Lubin	3	UNCLE BILL	Vitagraph	3
DEATH SIGN AT HIGH NOON.....	Kalem	3	THE FORTUNE HUNTER.....	Lubin	6
GAME OF LIFE.....	Selig	3	THE VENDETTA.....	Kleine	5
THE MILITANT SUFFRAGETTE.....	Pathe	5	BAREFOOT BOY	Kalem	3
FRANCIS MARION, "THE SWAMP FOX".....	Kalem	3	THE WIFE	K. & E. Biograph	3
A MILLION BID.....	Vitagraph	5	KING OF CHANCE.....	Kalem	3
THE FATAL WEDDING.....	K. & E. Biograph	3	THE WAGES OF SIN.....	K. & E. Biograph	3
THE GAMBLERS	Lubin	5	THE PLUM TREE.....	Essanay	3
ANNE BOLEYN	Kleine	3	THE FIFTH MAN.....	Selig	3
STRUGGLE FOR LIFE.....	Pathe	5	THE GOLDEN BEETLE.....	Kleine	4
MONGREL AND MASTER.....	Essanay	3	THE WEIGHT OF A CROWN.....	Lubin	3
THE ROYAL BOX.....	Selig	4	MARAH, THE PYTHONESS.....	Lubin	3
THE CURSE OF CREED.....	Melies	5	CHARITY BALL	K. & E. Biograph	3
FACING THE FOOTLIGHTS.....	Pathe	3	HEARTS AND MASKS.....	Selig	3
BLOOD WILL TELL.....	Essanay	3	A FLORIDA ENCHANTMENT.....	Vitagraph	5
CONQUEST OF QUEBEC.....	Kalem	5	ROAD TO YESTERDAY.....	K. & E. Biograph	3
THE LILY OF THE VALLEY.....	Selig	3	THE PAINTED WORLD.....	Vitagraph	3
CLASSMATES	K. & E. Biograph	4	JUDGE NOT	Kleine	4
MAN OF THE HOUR.....	Selig	3	GARRISON'S FINISH	Selig	3
MR. BARNES OF NEW YORK.....	Vitagraph	6	POWER OF THE PRESS.....	K. & E. Biograph	4
LOVE, LUCK AND GASOLINE.....	Vitagraph	3	IN THE GLARE OF LIGHTS.....	Essanay	3
THE BILLIONAIRE	K. & E. Biograph	3	THE RED CROSS NURSE.....	Melies	3
SPORT AND TRAVEL IN CENTRAL AFRICA	Pathe	5	THE THREADS OF DESTINY.....	Lubin	5
THE GOOD FOR NOTHING.....	Essanay	4	WHEN THE LIONS ESCAPE.....	Melies	3
THE BOER WAR.....	Kalem	5	THE GENIUS	K. & E. Biograph	3
THE THUMB PRINT.....	Melies	4	STONEWALL JACKSON'S WAY.....	Lubin	3
STRONGHEART	K. & E. Biograph	3	THE INVISIBLE POWER	Kalem	4
LORD CHUMLEY	K. & E. Biograph	4	THE WOMAN IN BLACK.....	K. & E. Biograph	4
SEVEN DAYS	K. & E. Biograph	3	UNDER THE GASLIGHT.....	K. & E. Biograph	4
TREASURE OF ABDAR RAHMAN.....	Pathe	4	"413"	Vitagraph	4
'NEATH THE LION'S PAW.....	Melies	3	THE WIN(K)SOME WIDOW.....	Vitagraph	4
ONE WONDERFUL NIGHT.....	Essanay	4	THE STORY OF THE BLOOD RED ROSE.....	Selig	3
WOMAN AGAINST WOMAN.....	K. & E. Biograph	3	THE TELL TALE HAND.....	Essanay	3
IN DEFIANCE OF LAW.....	Selig	3	A POOR RELATION.....	K. & E. Biograph	3
A KINGDOM AT STAKE.....	Kleine	3	THE LOCKED DOOR	Vitagraph	3
CAPTAIN ALVAREZ	Vitagraph	6	THE TANGLE	Vitagraph	4
OTHELLO	Kleine	5	THE SPY'S FATE	Lubin	3
SHANNON OF SIXTH.....	Kalem	5	IN THE DAYS OF THE THUNDERING HERD	Selig	3
			THE STRANGE STORY OF SYLVIA GRAY.....	Vitagraph	4
			THE BATTLE OF LOVE.....	Essanay	3



WILLIAM FOX

Productions Extraordinary

NOW BOOKING

THE WALLS OF JERICHO, by Alfred Sutro, with Edmund Breese and an all-star cast. This production was produced by James K. Hackett at the Hackett Theatre, New York, and ran 550 performances.

THE THIEF, by Henri Bernstein, with Dorothy Donnelly, creator of "Madame X", as produced by Charles Frohman at the Lyceum Theatre, New York, with Margaret Illington and Kyrle Bellew. Played to capacity for two years.

THE IDLER, by C. Haddon Chambers, with Charles Richman and Cathrine Countiss, as produced by Daniel Frohman with an all-star cast at the Lyceum Theatre, New York.

SAMSON, by Henri Bernstein (not the biblical play), with William Farnum, as produced by Charles Frohman at the Criterion Theatre, New York, with William Gillette and Constance Collier and had a remarkable run.

A FOOL THERE WAS, by Porter Emerson Browne, with Edward Jose and Thedda Barra, as produced by Klaw and Erlanger at the Liberty Theatre, New York. Was Robert Hilliard's greatest triumph.

Coming: **The Children of the Ghetto** with Wilton Lackaye and **The Girl I Left Behind Me** with Robert Edeson.

Some of the Biggest Hits in 20 Years

BOX OFFICE ATTRACTION COMPANY

WILLIAM FOX, President

Executive Offices: 130 West 46th Street, New York City

NEW YORK CITY, N. Y.—126 W. 46th St. Phone: Bryant 7340.
 WASHINGTON, D. C.—434 Ninth St., N. W. Phone: Main 1426.
 BOSTON, MASS.—10-12 Piedmont St. Phone: Oxford 6254.
 SYRACUSE, N. Y.—400 Eckel Theatre Bldg. Phone: Warren 119.
 PHILADELPHIA, PA.—1333 Vine St. Phone: Walnut 4503.
 PITTSBURGH, PA.—121 Fourth Ave. Phone: Court 1302.
 CLEVELAND, O.—618 Columbia Bldg. Phone: Cuyahoga Central 6260R.
 Bell: Main 5677.
 ST. LOUIS, MO.—3632 Olive St. Phone: Bell: Lindel 795; Kinloch: Delmar 7253.

KANSAS CITY, MO.—928 Main St. Phone: Bell: Main, 1008; Home: Main 7253.
 DALLAS, TEX.—1907 Commerce St. Phone: South Western: Main 2066.
 SAN FRANCISCO, CAL.—107 Golden Gate Ave. Phone: 4880 Market.
 DENVER, COLO.—Ideal Bldg., 17th and Champa Sts. Phone: Main 5071.
 MINNEAPOLIS, MINN.—Jewelers' Exchange Bldg. Phone: North Western
 Nicollect, 2498.
 SALT LAKE CITY, UTAH—McIntyre Bldg.
 CHICAGO, ILL.—314 Mallers Bldg., 5 S. Wabash Ave. Phone: Central 1716.
 SEATTLE, WASH.—1214 Third Ave. Phone: Elliott 1039.



Attendance Records Shattered *AGAIN!*

ZUDORA

Thanhouser's Greatest Photoplay

AGAIN all attendance records are shattered by a **Thanhouser** success. This time it's **Zudora**—the biggest, most elaborate and most unique motion picture production that has ever been offered exhibitors. Although only three episodes have thus far been released, reports of **CROWDED HOUSES** come from all over America.

Zudora is the creation of **Daniel Carson Goodman**, author, philosopher and scientist. The novelized version of **Zudora** has been written by **Harold MacGrath** and is now appearing in hundreds of newspapers throughout the country. The motion pictures of **Zudora** will be presented in 20 episodes of 2 reels each. A new episode is being released each week. The cast includes **Marguerite Snow**, **Harry Benham** and **James Cruze**.

Exhibitors: If you want a box office attraction that is bound to draw **PACKED HOUSES**—Book **Zudora**. See the **Thanhouser** Syndicate representative at any Mutual Exchange in the United States or Canada.



Trade Mark Registered.

Thanhouser Syndicate Corporation

71 West 23rd Street, New York

*Produced by Thanhouser Film Corporation, New Rochelle, N. Y.
Producers of The Million Dollar Mystery.*

208



Trade Mark Registered

DEC 14 1914

"When You See It
In 'The News'
It's NEWS"

Motion Picture News

HAS THE QUALITY CIRCULATION OF THE TRADE

"The Exhibitors"
Medium of
Communication"

TEL. 7650 BRYANT

TWO HUNDRED AND TWENTY WEST FORTY-SECOND STREET

NEW YORK CITY

Volume X

DECEMBER 12, 1914

Number 23

REPEAL OF KEYSTONE CENSOR LAW IS NEAR

United States Senator Penrose Assures Pennsylvania Exhibitors in Conference He is Opposed to Censorship and Promises Them Every Possible Aid—Thirty Thousand Dollars a Year Paid to Censor in Film Fees—Complain of Tax Injustices

Special to MOTION PICTURE NEWS

Philadelphia, Dec. 2. AS the result of vigorous representation made by members of the Exhibitors' League in Pennsylvania and the efforts of MOTION PICTURE NEWS in their behalf against censorship under the supervision of Federal, State or local officials, culminating in an interview of a delegation of producers and exhibitors with United States Senator Penrose on November 30, the repeal of the censor law in that state by the next legislature is almost an assured fact.

Senator Penrose made a statement favoring the repeal of the law, after hearing the reasons advanced by the committee and recognizing the justness of the views entertained by exhibitors throughout the state on this important question.

The Delegates in Conference with Penrose

The delegation comprised Fred J. Herrington, representing the exhibitors of Pittsburgh and vicinity, whose work as an organizer is well known; Morris Spiers, of Philadelphia; V. R. Carrick, of the Interstate Film Company; J. H. Butner, manager of the Mutual Film Exchange; Benjamin Zerr, of Reading; George Leavitt, of New York; P. Cropper, of the Exhibitors' League, and State Senator Joseph H. Thompson, of Beaver county, who obtained an audience for the delegation.

The spokesman of the film men, P. Cropper, pointed out to Senator Penrose the nature of the hardships now affecting exhibitors through the loose construction of the law. As it now stands the censor can determine, on his own volition, rather than through a strict interpretation of the measure, whether managers can display posters outside of their theatres, it was pointed out to the senator. The representative also declared that the law compels the payment on duplicate films, and that with the fees charged for this "service" and the state, federal and war tax exacted from them, cuts down the chances of making a reasonable profit to almost zero.

Senator Penrose was impressed with the arguments presented to him by the delegation, and declared that he would aid the film men in every possible way to remove the unjust conditions, a statement which, coming from such a source, made the representatives feel that the end of state censorship in Pennsylvania is in sight.

Exhibitors Caught Napping

State Senator Thompson stated that when the law was passed the exhibitors were caught napping, not realizing the manner in which the bill had been drawn. He made it clear that the exhibitors wanted no compromise on the situation, and declared in emphatic terms that an amendment of the law would not be satisfactory—nothing short of absolute repeal of the obnoxious law would remove the causes working a grave injustice to managers of motion picture theatres.

"This is class legislation," declared Senator Thompson.

(Copyright, 1914, by Exhibitors' Times, Inc.)

V. R. Carrick told Senator Penrose that in six months the censor had averaged 233 reels a week, making an average of \$30,000 a year in fees, an onerous charge on the producing companies. Mr. Carrick cited as an instance of the hardship entailed by the law that he had paid \$2,627 to date, including a fee on duplicates. In addition to this expense he had been obliged to pay a federal tax of \$600. Mr. Carrick, voicing the sentiment of the delegation, as well as the exhibiting body he represented, declared that the public should be the censor of films.

It was brought out at the interview that when the censor law was passed in 1911 J. Louis Breiting, the present censor, was a member of the House of Representatives, which, according to Senator Penrose, disqualifies him from holding his present office.

Pave Way for Fusion of Keystone Exhibitors

Special to MOTION PICTURE NEWS

Harrisburg, Pa., Dec. 2.

AN interesting meeting of the state officers of the motion picture exhibitors' league of Pennsylvania, held at the Commonwealth hotel, Harrisburg, Wednesday, November 18, for the purpose of conferring with the Motion Picture Exhibitors' Association as to amalgamating into one organization, proved most successful.

Those who attended the conference included: Ben. H. Zerr, J. G. Hansen, Frank A. Gould, Reading; Gilbert C. Miller, Plymouth; E. F. McAtee, Mahanoy City; Francis E. Devlin, Wilkes Barre. The association, which comprises the exhibitors from Pittsburgh and vicinity, was represented by Fred J. Herrington.

Mr. Zerr acted as chairman owing to the absence of President Sam. F. Wheeler. Chairman Zerr was given authority to make necessary appointments and arrangements for the convention.

Concluding the conference the following Harrisburg exhibitors were authorized to make the necessary arrangements for holding the convention and exhibit: I. Silverman, Clyde D. Klinger, Anthony George, C. Floyd Hopkins, John M. Lenney, I. Marcus and P. Magaro.

A general committee appointed by Chairman Zerr include the following: Reading: Frank D. Hill, J. G. Hansen, Harry J. Schad, I. A. Deisher and Frank A. Gould. Philadelphia: Dr. Walter Stuempfig, E. A. Jefferies, George Roth, M. J. Walsh, Jay Emanuel, F. Benn and S. Segall. Wilkes Barre: Fred W. Herrmann, Francis E. Devlin, Gilbert C. Miller, Edward J. Brislin. Scranton: M. E. Comeford, Geo. S. Thomas. Hazleton: Miss Mae Carr. Mahanoy City: E. F. McAtee. Ashley: Frank P. Gilligan. Bloomsburg: Wm. W. Fagely. Duryea: Harry Friedman. State College: Jos. P. Aikens. Nanticoke: A. Geo. Strojny. Beaver Falls: W. A. Pittis. Lucerne: Lewis Marinos. Wellsboro: A. H. Darrt. Larksville: R. J. McGowan.

Additional names will be added during the next ten days.

HAZEL DAWN RE-ENGAGED FOR "THE LOVE ROUTE"

Hazel Dawn, one of the most charming and talented of the younger favorites of the American stage, who made her debut before the motion picture camera in the Famous Players production of Bronson Howard's play, "One of Our Girls," has been re-engaged by that concern to star in



HAZEL DAWN

a film version of the famous comedy-drama, "The Love Route."

"The Love Route," by Edward Peple, author of "The Spitfire," and the recent comedy success, "A Pair of Sixes," is a romance of the ranch and the railroad.

TEST SUNDAY OPENING CASE IN KENTUCKY COURT

Special to MOTION PICTURE NEWS

Louisville, Ky., Dec. 2.

If it is shown that the ordinance of the city of Frankfort, Ky., passed in 1812, prohibiting business on Sunday has not been suspended, the Franklin Circuit Court must grant a writ of mandamus requiring Police Judge W. C. Herndon to issue a warrant at the instance of a citizen for the arrest of motion picture managers operating their shows on Sunday. Judgment of the Franklin Circuit Court refusing the writ has been reversed by the Court of Appeals.

The opinion handed down by the Court of Appeals is the result of a test suit brought by the city prosecutor. The police court has refused a warrant for E. K. Lyon, proprietor of a moving picture theatre, charging him with violating the Sunday law. Lyon came into the case and alleged that the ordinance had been repealed.

LEAH BAIRD MARRIED

Leah Baird, of the Vitagraph players, was married on Wednesday, November 28. After the ceremony, she attended the Screen Club Ball at the Hotel Astor, where her many friends of the profession had the opportunity of offering their congratulations.

Jeup Urges Co-operation In Detroit

Important Amendments to Motion Picture Laws Demand Presence Every Exhibitor at December 15 Meeting, Declares President

Special to MOTION PICTURE NEWS

Detroit, Dec. 2.

CO-OPERATION was the key-note of the regular weekly meeting of the Michigan Association of Motion Picture Exhibitors at the club rooms in the Equity building, Tuesday afternoon, November 24.

A number of matters were brought up showing how some exhibitors were violating the constitution; for instance, one playhouse on the east side was giving free matinees, or had given one free matinee and had intended to give others; another theatre had conducted raffle contests previous to Thanksgiving. The subjects caused considerable discussion.

President Jeup again referred to the coming semi-annual meeting, the definite date of which will be December 15, head-

quarters being at the club rooms, 255 Equity building.

"We have any number of important matters that we want to thrash out, which are of concern to every theatre and manager in the state," he said. "We cannot accomplish anything but having the co-operation of just a few exhibitors, but must have the help of all. The coming convention will be purely for business, no social entertainment being provided. We want the members to come here prepared to talk business and nothing else.

"We must get together before the legislature convenes and find out how our members feel relative to the various new amendments that are proposed to the moving picture laws," said President Jeup with emphasis.

R. U. THORNBURG.

California Will Release Through World Film

Beyfuss Completes Arrangements for Marketing on This Program "Mrs. Wiggs of the Cabbage Patch," and Other Important Pictures

THE California Motion Picture Corporation, through Alex. E. Beyfuss, general manager, has effected a plan to release its feature productions through the World Film Corporation. The initial offering will be a five-reel production of "Mrs. Wiggs of the Cabbage Patch," adapted from the novel by Alice Hegan Rice, as dramatized by herself and Anne Crawford Flexner, and originally presented by Liebler and company.

This feature will be released on January 4. Beatriz Michelena, whose work in "Salomy Jane" has made her famous in filmdom, will be starred as "Lovey Mary."

On January 18, the California corporation will release "Mignon," in a prologue and four parts, through the World Corporation. Beatriz Michelena's portrayal of the title part is said to be as nearly perfect as the art of acting in pictures can be effected.

The third release will be "The Lily of

Poverty Flats," a story based upon Bret Harte's poem "Her Letter, His Answer and Her Last Letter." In this production the California Motion Picture Corporation will try to outdo even "Salomy Jane" for scenic effects and stirring action.

Other subjects in preparation are "Salvation Nell," the famous play by Edward Sheldon, and "The Price She Paid," David Graham Phillips' story.

JURY APPROVES SUNDAY OPENING

Special to MOTION PICTURE NEWS

Jeffersonville, Ind., Dec. 2.

Ernest Deal, manager of the Dream Theatre, Louisville, was recently acquitted by a jury on the charge of a violation of the Sunday law by keeping open the theatre on the Sabbath.

There is no public sentiment in favor of Sunday closing and the verdict of the jury was a popular one.



NORMA PHILLIPS ("OUR MUTUAL GIRL") AND THE PRINCETON STUDENT BODY ON THE CAMPUS, PRINCETON, N. J.

Minneapolis League Is Getting Results

Aggressive Measures Inaugurated by Members Include Establishment of a Bureau of Theatre Sales, Employment Office, an Information and Interstate Relations Bureau and a Vigilant Legislation Committee—
Dues, Based on Seating Capacity May Be Abolished by Organization

Special to MOTION PICTURE NEWS
Minneapolis, Dec. 2.

ACTING on instructions granted at the convention of the Minnesota Motion Picture Exhibitors' Association, which give them a wide latitude, members of the executive committee are putting into operation new business systems which will more than double the service to the individual exhibitors. The aggressive work of this and other committees has already attracted the attention of older and wealthier trade organizations in other branches and by the next convention date there will be a new kind of exhibitors' league boosting the motion picture business.

The committee declares that it will have an organization by May 1 that will not have to have membership fees to keep it going. This point they wish especially to gain to prove the Minnesota association's side in its contention with the national body.

As most exhibitors know, the Minnesota association, since the bolt at the national convention in 1913, has not been affiliated with the larger body and the chief contention is that the assessment per capita is too much and is wholly unnecessary.

Plan to Do Away with Dues

By having every theatre in the state run an advertising slide and by careful management of the expositions conducted at the times of the annual and semi-annual conventions, the executive committee plans to do away with the dues which are now based on seating capacity of theatres. Each theatre now pays 1 cent a seat.

The association has moved into a new suite of offices on the fourth floor of the Temple Court building, and from there the officers will conduct this and other campaigns.

The new work includes establishing a permanent legislative committee, an employment bureau, a bureau for theatre sales, an information bureau and a bureau for interstate relations.

The constant danger of new laws that will work against the best interests of the business will be fought openly, and other trade organizations will co-operate in a large measure. To further the strength of this department, the executive committee will go to the Wisconsin convention in Milwaukee December 10, and there invite all exhibitors to join the Minnesota association. The Wisconsin men will pay a nominal fee for membership until the fees are done away with.

Next Convention, May 3-7

An interstate agreement by which Minnesota will help Wisconsin and Wisconsin help Minnesota will be worked out. Wisconsin men will be asked to participate in the next Minnesota convention and to come loaded with ideas.

The next convention date has been set for May 3-7, 1915, in Minneapolis, and

there will be another exposition in connection.

In the meantime the executive committee is going ahead with its service work. It already has its purchasing department in good working order. Now all theatres which are for sale will be posted in the offices and advertised in the association's bulletins.

The notices of persons who want to buy theatres will also be posted and the buyer and seller will be brought together at a

ers, musicians, ticket sellers and all others who are available for extra or permanent work.

The information department is already doing good service and the members are keeping W. A. Steffes, the secretary, informed as to all conditions affecting the business.

An example of the way in which this plan is working out was evidenced by the receipt of letters from sixty of the members regarding the decision to pay no return express charges on films. The charges are not being paid and the officers in this way learn how the convention's wishes are being carried out.

Practical Aids for the Members

The meetings of the local organizations are reported to Mr. Steffes. There are reports on films, on the way they are received by the patrons, the efforts of local authorities to aid or hinder the exhibitors, and in fact every feature bearing on the business.

The executive committee is making the association a year-around organization, with offices open at all business hours.

Members of the association have regretted that David Rodgers, of the Nicollet Theatre, Nicollet avenue and Grant street, has been compelled to give up his work as treasurer because of a prolonged trip to California, but they feel also that they are fortunate in having O. C. Stelzner, manager of the Star Theatre, 905 Twentieth avenue N., to handle the finances.

R. G. MARSHALL.

WHERE TO FIND IT

Department.	Page.
Live Wire Exhibitors.....	27
In and Out of Los Angeles Studios	37
Looking Ahead	31
Editorials	35
Among the Exchanges.....	33
Exhibitors' Forum	29
Feature Reviews	41-47
Program Reviews	48-50
Weekly Release Chart.....	115
Current and Coming Releases..	52-54
Release Dates for Ready Reference	55-57
ACCESSORY NEWS.....	103-116

saving to both. The commissions, which are often high, will be eliminated. This service will be free, as will all others.

In the employment bureau there will be kept a list of operators, electricians, sing-

Censors Resign; Urge End of Censorship

Los Angeles Board Sees No Need of Further Service as Manufacturers' Output Is Free From Objectionable Scenes

Special to MOTION PICTURE NEWS

Los Angeles, Nov. 30.

MRS. E. K. FOSTER, president; Florence Moore, secretary, and George W. Parsons, of the Los Angeles board of motion picture censors, filed resignations with Mayor Rose recently, and at the same time urged that the board be dissolved, as they believed there was no longer need for the members to spend their time viewing pictures, as the manufacturers had raised the standards to such an extent that censorship was not necessary.

The recommendations of the three retiring members was not heeded by the city officers and others have been named to fill the vacancies. Judge A. P. Tugwell, president of the local League, and member of the executive committee of the National League, has been named president of the board until the board is reorganized.

Judge Tugwell and other members of the local league were present at a recent meeting of the city council for the purpose of seeing that the recommendations of the retiring members were not carried

out. He was desirous of censorship.

"Local exhibitors are heartily in favor of a municipal board of censors," Judge Tugwell said, "because it gives us additional protection. We are not in favor of state or national censorship."

Mrs. Foster is a prominent society and club woman and has been president of the censor board since first organized three years ago, and Miss Moore has held the office of secretary for a like period. All members of the board, with the exception of the secretary, who receives \$75 per month, serve without pay.

The members take turn about viewing pictures and Friday of each week all go over the ones any members find below the standard.

FOR
BOX OFFICE TROUBLES
TRY
MOTION PICTURE NEWS
Those who have
are still taking it

Film Firms to Have Central Storage Plant

Entire Seventh Floor of Fireproof Building Will Be Devoted to Property of New York Concerns—Corporation Counsel Approves Project

WITH about forty-five tenants of the World's Tower and Candler buildings in trouble with the law because of their storage of film in violation to the fire ordinances, and similar difficulties hanging over the heads of occupants of other buildings in the theatrical center, the need of a central storage place for film has been focused into action. The entire seventh floor of the fireproof building at 345 West 40th street, New York City, is now being made ready for this purpose, and will be ready for occupancy December 15.

The New York City ordinance forbidding the storage of motion picture film within fifty feet of a theatre has for months been giving many motion picture companies anxious moments.

With the heart of the industry located in the theatrical district it is almost impossible to find accommodations in buildings not subject to fire violation visitations.

Film company representatives spent much time in consultation with the assistant corporation counsel of New York City in charge of the cases in point now in the courts, and evolved the project of building a general film storage headquarters in a fireproof building, legally distant from a theatre and yet convenient to the motion picture executive offices.

The exact specifications which would pass the regulations of the building and fire departments have been given out for

the installation of vaults of twelve inch concrete, with metal interiors. Double vault doors will give added protection.

The system of charges and handling of the film has been worked out carefully with the view of bringing the rates to a practical working basis. The film will be doubly protected by fire and burglar insurance. If the subscribing companies want their films called for and delivered this will be done at a commensurately small fee.

The assistant corporation counsel has declared to Joseph R. Miles that there will be no objection to the projecting of films in any building where the rules as to projecting are carried out. He also affirms that assurance to the court by the defendant film firms that they have made arrangements to store their films elsewhere will be accepted as a stay of proceedings, and that upon taken action within a reasonable length of time the suits will be dropped.

Dodgers of the law will be punished, he declares. It is even necessary to avoid the appearance of film storage, and inspectors will be entirely within their rights in breaking into lockers, trunks, desks, cabinets or anything they may suspect as concealing the proscribed combustible.

A direct telephone wire will be run to the Fortieth street building from the offices of the Films Lloyds, Inc., in the Candler building, who will conduct the storage operation.

HARRY WOODRUFF SIGNS WITH LASKY

The latest addition to the ranks of the special motion picture stars is Harry Woodruff, who, ever since the days of "Brown of Harvard," has been one of the most popular actors in America and whose fame has always been especially great with the matinee element Mr. Woodruff last



HARRY WOODRUFF

Acme of Photo Artistry for "Runaway June"

Reliance Company Obtains Services of Dr. Genthe, World Famous Expert, to Make Pictures of New Release

IN the new serial "Runaway June," by George Randolph Chester, now being produced by the Reliance Motion Picture Company, a novel mode of procedure is being adopted.

The Reliance company has realized the necessity of improving pictures from the artistic standpoint, and in its search for a man thoroughly versed in the pictorial side and artistic end of the business, hit upon Dr. Arnold Genthe, whose fame is world-wide as a still photographer.

Dr. Genthe, whose studio is located on Fifth avenue, has made a study for a great many years of light effects and color photography, and he is probably one of the best versed men in America in this particular line.

The minute details of motion picture photography are far too numerous to

trust entirely to the average camera man, and Dr. Genthe and his assistants make it a point to study all the conditions surrounding the taking of the various sets used in this production. In other words, before Oscar Eagle, the chief producer of "Runaway June," even sees a set, Dr. Genthe has had the same in hand and has completed all the details of lighting effects, camera work and such other points as are under his supervision.

HOW LUBIN DIRECTOR AIDED BELGIANS

Edgar Jones, the Lubin actor-director, hit upon a practical and far-reaching plan by which generous aid could be given the starving Belgians. He personally canvassed hundreds of farmers in his native county in Ohio, and by this means added a carload of foodstuffs to the cargo of the relief ship leaving Thanksgiving Day from Philadelphia.

"SUCH A LITTLE QUEEN" A HIT

Special to MOTION PICTURE NEWS

Washington, D. C., Dec. 1.

Mary Pickford in "Such a Little Queen" with a week's run at Moore's Garden did the biggest business that theatre has ever had, going \$600 above any previous attraction.

week signed a contract with the Jesse L. Lasky Feature Play Company whereby he is to play the stellar role in "A Gentleman of Leisure." Mr. Woodruff left for the Lasky studios in Hollywood, Calif., last Saturday. The taking of the picture will begin immediately, as it is already announced for release in February.

"A Gentleman of Leisure," which is to serve for Mr. Woodruff's entrance into the "picture field," had a very successful engagement in its original dramatic form at the Globe theatre about two years ago.

"SHE STOOPS TO CONQUER" A STRONG FILM

The Cosmofotofilm Company was fortunate in securing the London Film Company's four reel comedy, "She Stoops to Conquer." This perennial classic, which has endeared itself to the hearts of millions during the last one hundred and fifty years is well adapted to film presentation.

The producing company has evinced excellent judgment in the selection of a cast for creating the life and spirit of "ye olden time."

Jane Gail, Harry Ainley and Charles Rock make Goldsmith's famous characters live again.

This picture cannot help appealing to the most discriminating audiences. The reader who loves the wonderful old play and has read it time and time again, until the characters seem like living people, will be delighted to see these friends brought to life on the screen.

YOU DON'T EXPECT A FORTUNE TELLER TO GIVE YOU AUTHENTIC INFORMATION ABOUT THE FUTURE—

But you do insist upon it in the release charts of a motion picture trade journal. ACCURACY AND COMPLETENESS ARE THE STRONG POINTS OF

**MOTION PICTURE NEWS
RELEASE CHARTS**

FIVE PAGES IN EVERY ISSUE.
THE BEST TO BE HAD.

LIVE WIRE EXHIBITORS

EDITOR'S NOTE.—It is the desire of "Motion Picture News" to include under this heading novel advertising ideas, successful schemes in the management, decoration and equipment of the theatre—everything, in fact, done by the exhibitor to stimulate his trade. We invite every exhibitor to write us about any new enterprise he has; also to come to us for advice or information along any line. Address: Editor, "Motion Picture News," 220 West Forty-second Street, New York City

"SELIG WEEK" IN LOS ANGELES A SUCCESS

ONE of the features that helped to make "Selig Week" at Clune's Broadway Theatre, Los Angeles, a big success was the very excellent photographic lobby display. Three almost life size photographs—actual size 30 x 60 inches—were placed in the frames in the walls on each side of the lobby, while the large frame containing the small photographs designed in an "S" inside the Selig diamond, regularly stood in the center at the front of the lobby.

Manager Harry Hicks, of the General Los Angeles Exchange, selected the programme of five subjects and six reels in which all the leading people of the six Selig companies playing at Los Angeles studios appeared. No player appeared in more than one subject.

The photographic lobby display was prepared by the Photoplayers Studio, of Los Angeles, which makes a specialty of professional photographs, and has one large department devoted exclusively to the preparation of displays for motion picture theatres.

"Selig Week" was originated in compliment to Col. William Selig during his visit to the West Coast studios, and the first eve-

ning the program was shown all members of the Selig companies attended the performance in a body, as the guests of W. H. Clune, owner of the theatre.

LOBBY CLOCK PLEASURES PATRONS

THE patrons of the Garden Theatre, Battle Creek, Mich., are very much pleased with the management for installing a very fine mahogany clock above the ticket booth in the lobby. Around the sides are beveled glass signs containing advertisements.

AT LEAST FOUR REELS A NIGHT

THE Princess Theatre, Sturgis, Ky., has inaugurated the policy of showing not less than four reels every night. The "Trey o' Hearts" is now running at this house and getting big returns.

PRIZE FOR "AD" DESIGNS

A PRIZE of \$25 was awarded by the management of the Delft Theatre in Escanaba, Mich., for the best design submitted to be used on advertising matter.

AMERICAN BEAUTY ROSES FOR AMERICAN FILM

THAT a single reel picture can be featured and made to draw a heavy patronage by clever advertising was proven this week by Joseph Goldberg, manager of the Olympic Theatre, Louisville, who did a big business with "Motherhood," an American Beauty release on the Mutual program. Manager Goldberg, by means of circulars, advertised extensively through his neighborhood that this picture would be shown on a certain date and that to every woman patron an American Beauty rose would be presented. The interest of the women, especially, was aroused and the picture proved a great drawing card.

The Olympic is also conducting a "Missing Syllable" contest which is drawing patrons to the house in large numbers. Several sentences with the syllables of words omitted are shown on the screen and also on the theatre program and patrons are required to supply the missing syllables. A part of the last sentence, with one syllable missing, will not be known until it is shown on the picture screen on the last day of the contest. Tickets to the theatre are the prizes offered.

TWO WAYS OF DOING THE SAME THING; ONLY ONE PAYS

H. M. ANDERSON, owner of the Clay Theatre, Clay avenue, Detroit, Mich., and the Acme Theatre, Highland Park, has demonstrated the value of making something for nothing cost the receiver a little effort.

Mr. Anderson recently gave pictures of Ford Sterling as souvenirs at each of his theatres. At the Acme the pictures were handed out on a certain night without any previous announcement, and the audience received them languidly.

At the Clay Mr. Anderson announced several days ahead that on a certain night a picture of Ford Sterling would be given to each patron of the theatre. On the night in question the attendance was considerably increased and there was an eager reaching for the pictures on the part of the patrons.

PATRONAGE THROUGH PREMIUMS

THE Gem Theatre at Somerset, Ky., is increasing its patronage considerably by giving away premiums on certain nights of the week.

The only condition attached is that every one receiving a present shall have in his possession a copy of the Somerset "Herald" of the same date.



LOBBY DISPLAY AT CLUNE'S BROADWAY THEATRE, LOS ANGELES, DURING "SELIG WEEK"

RHEA HAINES MAKES HIT IN "COUNTRY MOUSE"

Rhea Haines, who plays Nell in the Bosworth production of "Burning Daylight" and Mrs. Van Zandt in "The Pursuit of the Phantom," by the same company, is a young actress who has come into prominence with the series of feature plays re-



RHEA HAINES

leased by Bosworth during the past year, and whose beauty and talent have aroused a great deal of favorable comment on every hand.

Miss Haines was born in Indiana, coming to California four years ago to make her home in Los Angeles. A chance visit to the Los Angeles studios with some girl chums resulted in an engagement.

Later she was engaged by Bosworth for Lizzie Connelly, in "Martin Eden," as being an unusually fine type for the role. Her work was so good and her screen appearance so striking that she has continued with the Bosworth company, playing leading parts.

United Film Service Is Now Well Under Way

Ludwig G. B. Erb's Company Putting Out Daily Releases of One and Two-Reel Subjects On This Program

THE United Motion Picture Producers, Inc., which has been organized with Ludwig G. B. Erb as president, has already begun operations under particularly auspicious circumstances.

The United Film Service is distributing the output of the new concern, which is comprised of single and double reel photoplays. Daily releases are being made and already a month's supply of subjects is ready for the market.

Mr. Erb, it will be recalled, was the first independent manufacturer of films in America. In association with David Horsley he organized, in 1908, the Centaur Film Company.

Mr. Erb next became associated with P. A. Powers, now president of the United Film Service (Warner's Features, Inc.), in the Powers photo-play company and was an important factor in the success that crowned that enterprise.

In 1911 Mr. Erb organized the Crystal Film company, which is one of the units to comprise the newly established program service. The inauguration of the new daily service will not interfere with the United Film Service's feature service, which is being continued as a separate service. The new daily service represents an augmentation of that firm's scope of activities—and a tremendous added responsibility that can be assumed on such short notice and with such complete mastery of detail because of its wonderfully developed facilities.

Among the talent brought under the wing of the United Motion Picture Producers, Inc., are Gene Gauntier, Dot Farley, Ethel Grandin, Charles de Forrest, Natalie De Lontan, Helen Gay, Mary Ainslee, Winna Brown, Florence Gail, Gerlaise Graham, Master Gilrod and Grace St. Claire.

Of the above, Gene Gauntier is the leading woman of the Gauntier Feature Play-

ers, long a producing arm of Warner's Features, Inc.

Ethel Grandin is the youngest leading woman before the camera. Miss Grandin appeared at different times, in support of Joseph Jefferson, Cecil Spooner and



LUDWIG G. B. ERB

Chauncey Olcott, as well as in vaudeville on the U. B. O. and Orpheum time.

Dot Farley is known to motion picture patrons not only as an actress of superlative qualities, but as a clever deviser of many of the dramas she appears in. Miss Farley is leading woman of the Albuquerque Film Company, producers of the famous Luna Brand.

EDISON PLAYERS SEE THEMSELVES ON SCREEN

An "Edison Night," held at the Regent Theatre, Lenox avenue and 116th street, New York, last week, attracted a large patronage on account of the novelty of the occasion.

Seven Edison players, guests of the evening, enjoyed the curious sensation of seeing themselves on the screen. They were Mabel Trunelle, Gladys Hulette, Miriam Nesbitt, Andy Clark, August Phillips, Herbert Prior and Marc McDermott. Horace Plympton, director of the studio, and Frank G. Bannon, the press representative of the Edison Company, acted as masters of ceremony.

CHICAGO REEL FELLOWS HOLD DINNER

Special to MOTION PICTURE NEWS

Chicago, Dec. 1. The Reel Fellows Club of Chicago held their monthly dinner on Wednesday evening, November 18, in the Italian Room of the Sherman House.

Not only was a large majority of the old members present, but several new names were added to the membership.



THE REGENT, NEW YORK, READY FOR "EDISON NIGHT"

The Exhibitors' Forum

MOTION PICTURE NEWS assumes no responsibility for any opinion or assertion made in the columns below, nor does the publication of a letter mean that the statements it contains are endorsed by the NEWS. All letters must be signed. No attention will be paid to anonymous communications

President Pearce Addresses the Producers

PRESIDENT MARION S. PEARCE, of the National League, has sent a letter to every film manufacturer in the country pointing out the efficient work of the League and citing the fight against the recent war tax. Mr. Pearce asks for the co-operation of the manufacturers in the efforts being made by the exhibitors in pushing various projects they have in view, and more especially in making the next annual convention and exhibit an unprecedented success.

An opinion is asked as to the selection of the 1915 convention city. The manufacturers were asked to state their preference. Up to date, Mr. Pearce has received replies from nearly all of the leading manufacturers and every letter speaks warmly of the regard in which the exhibitors' organization is held by the manufacturers.

What Exhibitors' League Has Done

A number of suggestions are made as to the choice for a convention city, but the latter will not be made public until after a meeting of the executive committee. This meeting will be held in the very near future, when a city will be decided upon for the 1915 annual meeting of the League.

The letter issued by Mr. Pearce to the manufacturers follows:

"Gentlemen:—I feel that I need do no more than remind you that the Exhibitors' League, each and every member of it, sincerely wish the heartiest co-operation possible between you and them. It's a thing you, of course, fully appreciate, and if proofs were necessary I feel that you need but recall the splendid work done by the League at Washington, and the efforts put forth to gain a reduction in the war tax.

"The finance committee (to which this bill was referred) agreed with us that a graded scale was more equitable and fair than a flat rate of taxation, but feared that a graded scale would tend to lessen the revenue from the bill, and that to reap this, in the measure desired, it would be best to include a tax for the manufacturer.

"We fought this to the end, and fought it successfully, as you know, with the result that the League brought out all sorts of influence to eliminate the tax on manufacturers—and it *was* eliminated!

"The National League will very shortly hold an executive meeting at which one of the important matters will be the choice of the city for the next annual convention and exposition.

Choice of a Convention City

"We want to select a city that will meet the approval of the exhibitors, at the same time prove agreeable to the manufacturers. We realize fully that in some instances in the past the manufacturers have had honest and just cause for complaint.

"We're going to avoid all this at our next convention and exhibition. We're going to conduct it along business lines, so it will be a pleasure to every manufacturer to have an exhibit included, and so he will realize some real business benefit from the expense this exhibit has cost him, and make this benefit so large that he'll be glad to have participated in it.

"The convention will be so conducted that it will be a real help; it will be a real budget of helpful information in handy form, and the incidents and various portions of the features of such a nature that an exhibitor may return to his home with valuable information which he can turn into profits in his own business.

"Not the least feature will be the assurance of your having ample time to place your products before him and get in touch with him in a way that is sure to impress him and bring results to you.

"The League is growing! It's growing healthily! Frictions and factions are being eliminated, and amalgamation is going on apace.

Asks for Views of Manufacturers

"We've had many suggestions as to the city for the next convention and exposition. Some favor San Francisco, on account of the Panama-Pacific Exposition, feeling that thousands would like to attend the two. Others feel that New York City is the logical place, being the headquarters of the motion picture industry. Still others seem inclined toward Chicago and Philadelphia, in view of the fact that New York has been the scene of several previous conventions.

"We'd appreciate your views and your preference in this connection. I'd thank you for an expression as to which city you think best, and assure you that your choice will have weight enough to assist us greatly in locating the next convention.

"With best wishes, I am

"Very truly yours,

"(Signed) MARION S. PEARCE, Pres.,
"M. P. E. L. of America."

The Censorship Situation in Ohio

"Cleveland, Ohio, Dec. 1, 1914.

"Editor, MOTION PICTURE NEWS, New York City.

"Dear Sir: The elections being over in Ohio, the situation now appears favorable to ridding this free state of ours from the Russianized idea of censorship.

"The proposition to foster this un-American idea through the medium of a proposed so-called 'official trade organ' has been nipped in the bud, at least one of its sponsors having 'backed up' on the official censors' 'medium of communication between the censor and his victim.'

"Just now is the time for the big fellows in New York to 'put up' the necessary funds to scotch and kill the Ohio law by repealing it during the coming session in January.

"We know what the sentiment in Ohio is. It took a lot of hard work and considerable money to conduct a campaign to find it out. Cleveland stood for it all and not one cent would the big manufacturing groups in New York contribute, though an appeal was made to all of them.

"The only individual to subscribe was C. G. Thompson, of the Victor Film Company, of Cleveland.

"Exhibitors are entitled to film under contract without having to fight the state to prove that it is 'clean.'

"The producer, after consenting to the 'cleaning' process through the medium of the National Censor Board, should fight off at their own expense the political grafters of Ohio and elsewhere and leave the exhibitor free from stigma and expense to show their goods 'clean' from the studio.

"That is what he pays for and that he is entitled to.

"Heretofore they, each of them, as manufacturers, have allowed a little group of grafters to proceed as they saw fit.

"Beautiful productions have been mutilated shamefully. Hosts of feature and regular film agents have camped at Columbus awaiting the pleasure of the official 'cleaners' to get their film out.

"Scores of valuable bookings have been canceled through delay. It is a daily occurrence yet for green, out-of-town, would-be-showmen-who-never-subscribe-to-trade-papers to phone in 'Where's the Ohio censor leaders for film so-and-so that you sent me today?'

(Continued on page 46)

TENSE MOMENTS FROM SOME OF THE COMING RELEASES ON THE MUTUAL PROGRAM



"NAIDRA, THE DREAM WOMAN"
(Thanouser, Dec. 4)



"THE FOREST THIEVES"
(Reliance, Dec. 9)



"THE BARRIER OF FLAMES"
(Thanouser, Dec. 15)

Mica Plans National Publicity Campaign

Corporation Will Use 1,800 Daily Newspapers, At an Expense of \$500,000 a Year, for Making the Name "Kriterion" Well Known Everywhere

UNDOUBTEDLY the greatest surprise hitherto announced of the series of surprises which has marked the development of the Kriterion program is the one announced this week by the Mica Film Corporation, the company producing Kriterion pictures.

A nation-wide advertising and publicity campaign will be commenced immediately

The cost of such a campaign as the Mica Film Corporation contemplates will be, it is estimated by the officers of the company, not less than \$500,000 a year. But the results to be obtained justify this expenditure, they declare.

To help the exhibitor make a success of the Kriterion program, to share the advertising and publicity expense with him, is the thought underlying the campaign. In every town where the Kriterion pictures are to be shown there will be advertisements in the newspaper which is a member of Mr. Fagan's service, introducing Kriterion pictures to the public and announcing the name and location of the theatre which will be the home of the Kriterion program for that vicinity.

Accompanying these advertisements at suitable intervals there will appear reading notices in the columns of these newspapers to acquaint the public and keep them familiar with the Kriterion productions, their stars, plays and qualities.

In this manner the producers of Kriterion pictures will awaken and stimulate the necessary demand for Kriterion film at their own expense, of which the exhibitor who is showing them will reap the profits. The exhibitor will pay nothing extra for this service. It will accompany every Kriterion contract, for the Mica Film Corporation considers that such co-operation between manufacturer and exhibitor is the surest, fairest and most practical method of marketing its product.



MYRON C. FAGAN

by the Mica Film Corporation in hundreds of newspapers all over the United States for the benefit of Kriterion pictures, and the exhibitors who are to use them.

This has been made possible by a contract with the National Newspaper Publishers' Drama Service Bureau, of New York City, of which Myron C. Fagan is editor-in-chief, and which represents the dramatic departments of approximately 1,800 American newspapers.

Exhibitors are already well acquainted with Mr. Fagan since he became identified with the movement for better pictures and commonsense censorship.

LUBIN FILMS FIVE FEATURES AT SAME TIME

To commence four big features, two of them five reel length and one six, and produce them practically simultaneously, is a feat that is seldom attempted or encouraged among producers. Romaine Fielding, producer, author and leading man for the Lubin company, has accomplished this feat, however.

"In the Hour of Disaster," in five reels, "The Disaster" in five reels, "The Brute in the Jug," in two reels, and "The Valley of Lost Hope" in six reels, are the titles of the plays in question.

GASKILL WRITES VITAGRAPH PLAY

Charles L. Gaskill has written a new play for the Vitagraph Company, to be produced under his personal direction, and calling for a display in full of the dramatic art of Helen Gardner, and demanding sets of striking originality.

BLISS MILFORD WITH AUGUST AT KINETOPHOTE

Edwin August has started on the first picture which he will make for the Kinetophote Corporation, which he recently joined, and for which he will produce as well as star in several famous stories. Bliss Milford, who has been playing leads with the Edison Company for three years, will be leading woman for Mr. August and will appear in his first production for the Kinetophote.

Miss Milford comes to the Kinetophote with a fine record and a long list of films in which she has appeared. During the time that she played with the Edison she



BLISS MILFORD

appeared in 125 different films, and her roles ran the whole gamut from pathos to broad comedy. She was on the stage for five years previous to going into pictures.

Miss Milford was born in Fargo, North Dakota. Her family removed to New Orleans while she was a young child, and she was later taken to Chicago, where she was educated.

Looking Ahead With The Producers

"The Last Egyptian" to Be Next Alliance Release

CONTRACTS have been signed by Andrew J. Cobe, general manager of the Alliance Film Corporation, and the Oz Film Company, whereby all future productions of the latter concerns are to be released on the Alliance program.

The first offering will be "The Last Egyptian." This picture is a radical departure from anything yet produced by the Oz company. It will be released December 7.

The film tells a strong and well constructed dramatic story of modern Egypt. L. Frank Baum, who wrote the scenario and put the picture on, proves that he is as adept and ingenious as a dramatic pro-

ducer as he is a creator of fantastic romances of Ozland.

Mr. Baum has given the picture magnificent settings. An agreement has been arrived at between the two firms whereby Mr. Baum is to produce popular plays and novels to be selected by the Alliance heads.

Mr. Cobe, in speaking of this clause in the contract, said: "This will eliminate the making of productions for which there are no markets. Through our exchanges we keep a close watch upon the pulse of public demand, and we trust that we will be able to know whether the public want a picture before it is made and not afterwards."

FAMOUS PLAYERS SECURES BARRYMORE TO APPEAR IN, BROADWAY SUCCESS

The Famous Players Film Company has secured two such noted stage successes as "Are You a Mason?" and "The Dictator," in which they will present their popular star, John Barrymore, who made his first appearance in motion pictures in



JOHN BARRYMORE

the Famous Players production, "An American Citizen," and who achieved an unusual comedy triumph in that company's recent release, "The Man From Mexico."

"Are You a Mason?" and "The Dictator" were selected as vehicles for Mr. Barrymore for the reason that they represent, more than any other comedies of a similar reputation, the type of dramatic humor best adapted to the inimitable talents of this star.

YACHT SUNK FOR LUBIN PRODUCTION

The sinking of a Herreshoff steam yacht off Jacksonville, Florida, and the plunge of a touring car from a wharf into the ocean are two of the sensational features of the two-reel photoplay "The Man from the Sea," which is released by the Lubin Manufacturing Company, December 10.

"The Man from the Sea" was written by Charles Goddard and Paul Dickey, authors of "The Ghost Breaker" and "The Misleading Lady" and was adapted for the camera by George Terwilliger, of the Lubin staff of directors.

In order to get the proper background for the story, Mr. Lubin sent a special company to Florida.

Real Dinosaur Bones for McCay Comedy

WINFIELD R. SHEEHAN, general manager of The Box Office Attraction Company, through the good offices of the directors of The Museum of Natural History, secured the use of the classic museum building as a setting for some of the scenes in the unique Winsor McCay comedy, "Gertie, the Dinosaurus."

The skeleton of the dinosaur on exhibition at the museum is an extraordinary specimen. The bones weigh about a ton, and it stretches almost the entire length of the museum floor. There are more than four hundred separate joints to the skeleton framework of this pre-historic monster. Winsor McCay's "Gertie" shows what a dinosaur may have done in the dark past

and what it would do were it living in the immediate present.

Besides Winsor McCay, Roy McCardell, the humorist, and George McManus, of Newlywed fame, appear in the picture.

CAST FOR "LAST CHAPTER" IS ANNOUNCED

The cast for the January release of the Favorite Players production, "The Last Chapter," for the Alliance program, has been announced by Director William Taylor, which includes Carlyle Blackwell, Ruth Hartman, Ollie Kirkby, Mrs. Pratt, John J. Sheehan, Henry Kernan, and William Brunton.



SCENE FROM "THE LAST EGYPTIAN" (Oz-Alliance Feature)

TERRISS PUTS ON "A MAN'S SHADOW"

Tom Terriss has started work at the Kinetophote studios at Coney Island on the first of the series of famous Terriss plays, which he will produce and star in for the Kinetophote. He chose "A Man's Shadow," which he wrote for his father, the great William Terriss of the London stage.



ANNA LUTHER

Anna Luther, who has been a Lubin star for more than a year and who previous to that was a member of the old Reliance Company, where she went to leads within two months after having been cast for her first screen drama, has been chosen by Mr. Terriss to play opposite to him in the new piece. She will have the part of the wife in "A Man's Shadow."

Miss Luther is not only known for her beauty, which gained for her the titles "The Poster Girl" and "The Fifth Avenue Girl," but also for the many daring things which she has done in pictures. She was born in Newark, N. J., not so very many years ago and went in for pictures about two and half years ago.

BALBOA ENGAGES DOROTHY GRANVILLE

Contract has been made by Messrs. Horkheimer, of the Balboa company, at Long Beach, Cal., with Miss Dorothy Granville, well-known legitimate stage star, to play leads in their feature productions, and the first in which she takes part will shortly be taken up. The company is now having elaborate sets made.

Miss Dorothy Granville's first appearance on the stage was in San Francisco, following her common school education and two years at Wellesley College, in Massachusetts, where she became a member of the Alcazar Theatre Stock Company, playing ingenue and character parts. Later she played with the Kolb & Dill Company at Fischer's Theatre, in the same city. Next she played an important part in the Mort Singer Company's production of "His Highness, The Bey."

Alco Announces Schedule of Releases

THE Alco Film Corporation, under the guidance of its new directorate, with President Walter Hoff Seely at the helm, announces a long list of high class releases beginning with the Popular Plays and Players production of "The Tigress," which, with Madame Olga Petrova, will be seen Monday, December 7.

Through the producing companies affiliated with the Alco, the following high class plays and acknowledged stars will be introduced to the screen.

December 7, Olga Petrova, star of Panthea in "The Tigress," from the studios of Popular Plays and Players Company.

December 14, Mabel Taliaferro, formerly seen in "Polly of the Circus," "Springtime," "Young Wisdom," etc., in B. A. Rolfe's production of "The Three of Us," based on the stage production of the same name.

December 21, Mack Sennett's production of the exhilarating comedy, "Tillie's Punctured Romance," in which Marie Dressler, Charles Chaplin and Mabel Normand are featured.

December 28, "Springtime," from the plays, by Booth Tarkington, with Florence Nash in the leading role. Life Photo Film Corporation, producers.

January 4, Jane Cowl, the stage's most attractive star, in the All-Star Feature Corporation's production of "The Garden of Lies."

Successful plays, with real stars, will feature the Alco program in the future. Another prominent producing concern will announce affiliation with Alco shortly, after which the entire program from the first quarter, ending March 1, will be announced.

HARRY MESTAYER TO PLAY LEAD IN "STOP THIEF"

George Kleine announces that Harry Mestayer has been secured to play the "lead" of the thief in his film version of the Cohan-Harris comedy "Stop Thief," work on which has already commenced at the George Kleine studio, 11 East Fourteenth street, New York.

"Sign of the Cross" Released December 21



WILLIAM FARNUM (RIGHT) IN "THE SIGN OF THE CROSS"
(Famous Players-Paramount Feature—December 21)

THE Famous Players have decided to change the release date of the spectacular film version of Wilson Barrett's immortal drama, "The Sign of the Cross," originally scheduled for release in February, to December 21. The change was made because of the peculiar appropriateness of the subject as a pre-Christmas release.

The Famous Players impressive production of this sublime drama created a furore throughout England, where it was released during the summer in order to fill booking dates secured as early in advance of the production as last February.

"The Sign of the Cross," derived from

the symbol which to scores of millions has for many centuries borne so profound a significance, has been filmed by the Famous Players with an extravagance of scenic and spectacular effects and a faithfulness to the original settings and atmosphere seldom seen in motion pictures. For the most part it glows with coloring, as befits a fearless picture of life in the Rome of the Emperor Nero.

It would be impossible to over-estimate the emotional power of the film. In the role of Marcus Superbus, William Farnum attains the loftiest dramatic heights of his career. Miss Rosina Henley makes a sweet and womanly Mercia.

AMONG THE EXCHANGES

FROM LOS ANGELES EXCHANGES

AL JOHNSON, for the past year salesman for the General Film Company, Los Angeles branch, has been transferred to the Denver exchange, and has departed for that place.

Charles Cochard, who has been manager of the poster department of the Los Angeles general exchange, has resigned and will return East, and W. H. Hepburn, manager of the projecting machine department, will in the future superintend both the poster and machine departments.

Arthur Lamb, auditor for Warner's Features, Inc., is spending a couple of weeks at the Los Angeles exchange at 527 West Eighth street, with Manager G. R. Sirwell.

Leon D. Netter, manager of the San Francisco exchange of the Alco Film Corporation of California, spent the past week here getting acquainted with the methods of Manager E. H. Emmick, and making a general study of the conditions regarding feature films.

Upon the release date of the two latest serial pictures, "The Master Key," Universal, and "Zudora," Thanhouser Film Corporation, Los Angeles exchanges reported very successful booking, both having contracts with thirty odd theatres for the use of these pictures.

"The serial picture has been very successful with us," Dave Bershon, manager of the Los Angeles branch of the California Film exchanges, said. "We are still making booking for the first number of 'Lucile Love,' and the demand for 'The Trey o' Hearts' is now practically as good as when first released. Of course we do not receive the rental now that we did sixteen weeks ago."

CASINO CONFISCATES FILM

THE Casino Feature Film Co., of Detroit, confiscated the "Fangs of Hate" feature film, which was shown without permission at the Rosebud Theatre on November 17. The Casino company have full Michigan rights on all Ramo features, and although the owners of the Rosebud had purchased a copy of the film from some outside party, they were violating the rights of the Casino company in attempting to exhibit same.

OLD FACES IN NEW PLACES

RICHARD BRODERICK, of Detroit, who has been temporarily at the St. Louis office, is now taking charge of the Warner's Features in Kansas City as manager.

The film exchanges of Philadelphia report business good and everybody happy. There have been several interesting shifts in managerial circles recently.

Harry Schwalbe, former manager of the

General Film Company in Philadelphia, is now in charge of the Electric Theatre Supply Company, in which he is interested. Mr. Schwalbe succeeds "Bill" Heenan in the management of Electric affairs.

Mr. Heenan has taken over the general management of the Stanley Booking Company, succeeding George L. Mann, the latter having gone to Washington to take charge of the Famous Players Exchange in that city.

KANSAS CITY UNIVERSAL ENLARGES QUARTERS

THE Kansas City manager of the Universal, R. C. Crooper, is having the quarters enlarged and making many changes since the disastrous fire. The firm will occupy all of the second floor over the Empress theatre, except the three rooms at the east end of the building.

Under Mr. Crooper's management the business has grown very rapidly, and while they have a short time lease, more space and conveniences are necessary to keep up with their orders. Among the improvements is a fireproof vault with storage capacity for about 2,000 films.

JENSEN WITH CELEBRATED PLAYERS

EMIL C. JENSEN, for three years with the Kinemacolor Company of America, first in New York, and then as branch office manager in Chicago, goes back to the Chicago field, with which he is well acquainted, on November 30, as assistant to Felix Feist, the general manager of the Celebrated Players Film Company.

Mr. Jensen, while still a young man, is pushing himself forward, and recently he was the senior partner in the Feature Booking Office of Brooklyn.

EIGHTEEN LOUISVILLE HOUSES TAKE "ZUDORA"

J. G. CONNER, the Thanhouser representative in the Louisville territory has just closed contracts with eighteen motion picture theatres in Louisville for the serial production "Zudora." Simultaneously with the release of the films installments of the story of the play will appear in the "Louisville Times." The first installment of the play was shown Monday, November 23.

SPITZER KANSAS CITY MANAGER

S. DEMBOW, the district manager of Box Office Attraction Company, has secured the services of N. H. Spitzer as manager of its Kansas City office. Mr. Spitzer was former president of the Kansas City Exhibitors' League. The success of "The Million Dollar Mystery", locally is credited to his forceful efforts.

WEEKLY WASHINGTON RECEIPTS INCREASED FROM \$150 TO \$2,000

ON November 19 the Washington change of the World Film Corporation celebrated its first anniversary in Washington, during which time it has been under the able management of Wm. H. Irvine, with his son, Alex. G. Irvine, as assistant. Speaking of the development of this office, the elder Mr. Irvine had this to say:

"I am thoroughly pleased with the progress we have made in our territory, and the outlook is that we will make even greater progress in the future. From weekly receipts of \$150 we have increased to \$2,000 a week, and we have been able to place our program in all the important houses in the large cities."

"Washington and Baltimore especially have appreciated the worth of productions under our control, particularly the Shubert productions.

"The introduction of features in the South has not been an easy task, sometimes because the managers will not risk the extra expense and sometimes simply because they lack the spirit of making a change. Besides, the Southerner must be handled diplomatically, according to his ideas of business.

"On this particular point have so many exchange men failed. It is to my previous experience in theatrical managing in the South that I owe my present success in placing the World Film Corporation features, but there is much more work to be done."

DETROIT EXHIBITORS AFTER "MASTER KEY"

FROM the bookings that the Detroit Universal Film Company is making and the flood of inquiries it is receiving, it appears that "The Master Key" will be one of the most popular serials that has ever been presented in Detroit.

The exchange is having all that it can do to take care of the exhibitors who want the serial, and incidentally some very clever advertising matter has been put out in behalf of the feature by the management of the Detroit office.

ALCO FILMS POPULAR ON COAST

THE Alco program is receiving a very welcome reception in Los Angeles, Southern California and Arizona, and the first releases of the program made through the Alco company of California, under the management of E. H. Emmick, are now booked solid until the middle of January. The demand from out-of-town exhibitors has been greater than could be accommodated.

MORGAN BUYS INTEREST IN LOS ANGELES EXCHANGE

O. V. TRAGGARDH, owner of the Union Film and Supply Company, with main office at San Francisco and branch in Los Angeles, was here this week looking after local conditions. Incidentally he made the announcement that W. J. Morgan, pioneer film exchange man of the west coast, has purchased an interest in and will take charge of the Los Angeles exchange, December 7.

Mr. Morgan is perhaps one of the best known men engaged in the film renting business. He engaged in this business here ten years ago, at that time being connected with the Edison Display Company. This company later became the Amalgamated Film Exchange, which was taken over by the General company. When the General took over the business Mr. Morgan went to Australia, where he spent a year, and has since been general manager of the Pacific Mutual exchanges at Seattle, Portland and Spokane.

The sale of an interest in this exchange was made by Mr. Traggardh, who is president and general manager of the Supreme Feature Film Company, of San Francisco, in order that he would be in position to give more time to the sale of feature films by state rights. At this time the company is marketing "Beasts of the Jungle," a very unusual wild animal picture made by the E. & R. Jungle Film Company, of Los Angeles.

ALLIANCE INVADES CANADA

ANDREW J. COBE, general manager of the Alliance Films Corporation, has just returned from Montreal where he has made arrangements with the Noted Players Feature Film Company, to handle all Alliance releases in the Dominion.

J. D. Goldie, the head of the Noted Players, will shortly have in addition to the Montreal exchange, fully equipped offices in Toronto and Winnipeg. These are to be followed by other branches in the larger Canadian centres.

The projected offices will be located in St. Johns, Calgary and Regina. The St. Johns office will handle the Nova Scotia, New Brunswick, and Prince Edward's Island territory. Winnipeg will take care of the Manitoba, Saskatchewan, Alberta, and British Columbia.

UNITED FILM SERVICE OPENS TOLEDO OFFICE

THE United Film Service has established a branch office in Toledo, Ohio. The new exchange is located at 413 Summit street and is in charge of Bert Diener. Expansion of business has dictated the establishment of the new office, which brings the list of United Film Service exchanges up to 43.

WEST WANTS UNITED PROGRAM

J. C. WOOLF, manager of Warner's Features, Inc., in Kansas City, is wearing the "smile that won't come off." He has accepted the inter-mountain territory for his firm, and reports a big demand for the new United Program.

Los Angeles Exhibitors Fight City Supervision

Proposed Change in Charter of Coast City Would Bring Theatres Under Autocratic Rule of a "Manager"—Slide Campaign Has Begun

Special to MOTION PICTURE NEWS

Los Angeles, Nov. 30.

IN addition to the five bills relative to motion pictures and theatres to be introduced at the coming session of the California legislature, Los Angeles and Los Angeles county motion picture theatre men are facing proposed local legislation of a very drastic and undesirable character, which means placing all motion picture films and theatres under the supervision of the police department.

On December 31 the citizens will vote on whether the city should adopt the "manager" system, and broaden the scope of the present city charter. Should the proposed change be favored by a majority of the voters, the questions provide that there shall be a manager of the police department who shall supervise all saloons, billiard and dance halls and motion picture theatres, as well as inspect all films to be shown in the city.

The bills as presented to the voters provide further that this manager shall have the power to censor any subject, reel or portion of a reel of motion pictures, and personally regulate the motion picture theatres.

This proposed legislation further provides for the disposal of the municipal board of censors, which was established

three years ago by an ordinance adopted by the city council.

The matter was the principal subject discussed at the special meeting of the local Exhibitors' League, held November 25, and plans were formulated and will be completed at the next regular meeting, for a very strenuous campaign against the measures. Inasmuch as the censor board, of which Judge A. P. Tugwell, president of the League, is president, has always worked in harmony with the exhibitors, it is the desire of all that present conditions should continue.

By the time this issue reaches the readers of the News all exhibitors of this country, numbering 150 or more, will be showing at their theatres various slides pointing out the injustice of the proposed municipal and county legislation.

Complaints were made by exhibitors at the special meeting of the League concerning one local film exchange cutting off service and giving it to another exhibitor who offered higher prices, without first affording the first user an opportunity to meet the bid of the second. A special committee was appointed to investigate the charges, and if conditions warrant, members will probably boycott this exchange unless assurance is given that speedy reparation will be made.

J. C. JESSEN.

How "Productions Extraordinary" Are Made

Realism to a Startling Degree Attends William Farnum's Action in "Samson," Now Being Filmed for William Fox at Jersey City Studios

"MAURICE BRACHARD," William Farnum, star of "Ben Hur," "The Littlest Rebel," "The White Sister," "Ingomar" and countless classical productions, was having his knuckles "taped" in one corner of the big Pathe studios in Jersey City, now leased by the William Fox Box Office Attraction Company, preparatory to smashing in with his fists a heavy door. The play, being filmed under the direction of Producer Edgar Lewis, was Henri Bernstein's "Samson."

Three cameras were posted to take the door-smashing stunt for a re-take. Ten of the huskiest stage hands employed in the studio braced themselves against the back of the set, representing an upper hall in Brachard's (Samson's) home. Mr. Farnum, with a "house-breaking" matrimonial grouch vividly depicted on his features, grimly marched up the stairway to the boudoir door. First came a gentle knocking from importunate hubby on the closed portal, a sort of hint as it were. Then ensued the assault of the big siege guns in the form of an angry battering. This bringing no result the handle of the barrier was violently rattled.

"Now let her have it!" yelled Mr. Lewis. Bing! Bang! "Ouch!" Arnica was sent for and, after his bruised knuckles had been bathed, Mr. Farnum resumed his search for his "wife," played by Maud Gilbert.

The above is just a sample of the thor-

oughness with which every detail in the William Fox Productions Extraordinary are carried out. The three big studios permit of productions being built with thoroughness. Light, after all the most important element entering into photography, be it "still" or "motion," is a question that has been attended to by actinic experts and as the studios are comparatively new they have the advantage of possessing practically the very latest developments in this science. Recently three big sets were staged at once in the No. 1 studio and three directors worked on as many scenes without conflict over space or lights.

Since the Box Office Attraction Company took possession of the studios such famous stars as Charles Richman, William Farnum, Robert Edson, Edmund Breese, Stuart Holmes, Walter Hitchcock, Dorothy Donnelly, Catherine Countiss, Claire Whitney, Maud Gilbert, Maud Turner Gordon and many others have appeared within their walls.

YOU CAN'T FAIL
to find what you want in
MOTION PICTURE NEWS

because

MOTION PICTURE NEWS IS MADE TO
MEET EVERY ONE OF YOUR WANTS
BY MEN WHO KNOW WHAT
YOUR WANTS ARE.

Motion Picture News

HAS THE QUALITY CIRCULATION OF THE TRADE

MOVING PICTURE NEWS EXHIBITORS' TIMES
Published Every Week by

EXHIBITORS' TIMES, Inc.

New York Offices 220 West 42nd Street
Chicago Offices..... 223 West Jackson Boulevard
Los Angeles Offices..... 427 South Figueroa Street

WILLIAM A. JOHNSTON.....President
HENRY F. SEWALL.....Vice-President
E. KENDALL GILLET.....Secretary
H. ASHTON WYCKOFF.....Treasurer
WENTWORTH TUCKER.....Ass't Treasurer

WILLIAM A. JOHNSTON.....Editor
LESLEY MASON.....Managing Editor
WILLIAM RESSMAN ANDREWS.....News Editor
H. ASHTON WYCKOFF.....Business Manager
R. M. VANDIVERT.....Advertising Manager
E. J. HUDSON.....Circulation Manager
THEODORE S. MEAD.....Chicago Manager
J. C. JESSEN.....Los Angeles Manager

This publication is owned and published by Exhibitors' Times, incorporated under the laws of the State of New York. The offices and principal place of business are at 220 West 42nd Street, New York City. The address of the officers is the office of the publication.

Entered as Second-Class matter at the New York Post-Office.

Subscription \$2.00 per year, postpaid in the United States, Mexico, Hawaii, Porto Rico and the Philippine Islands. Canada, \$3.00; Foreign \$4.00 per year.

ADVERTISING RATES ON APPLICATION.

Copy for next issue must reach us by Tuesday, 5 p. m.

Cuts and copy are received subject to the approval of the publishers and advertisements are inserted absolutely without condition expressed or implied as to what appears in the text portion of the paper.

Vol. X December 12, 1914 No. 23

The Growth of the League

“THE League is growing,” says President Marion S. Pearce, of the Motion Picture Exhibitors League of America, in a recent letter addressed to the motion picture manufacturers.

“It’s growing healthily. Frictions and factions are being eliminated, and amalgamation is going on apace.”

One of the best evidences of the truth of President Pearce’s observation is to be found in the history of the activities of the California State League since the October convention of exhibitors in that state.

* * *

AT that meeting, when President Beach was elected to the state leadership, W. A. Cory was, at his own suggestion, made “state organizer,” as it were, commissioned to canvas California and bring new members into the ranks.

Mr. Cory has been engaged in this work for five or, at the most, six weeks.

The results have been gratifying, even to the staunchest believers in the League. They have been astonishing to the croakers and the pessimists.

* * *

TO-DAY, as the direct result of Mr. Cory’s endeavors, the California State League is one of the most flourishing in the country, and the Los Angeles local shows the greatest percentage of exhibitor enrollment in the West.

Eighty per cent. of the exhibitors of Los Angeles and vicinity are members, and both Judge A. P. Tugwell, the President, and Mr. Cory, who is also state secretary, expect that every motion picture theatre manager will be one of them before the campaign is concluded.

It is a fact of further significance that before the arrival of Mr. Cory in Los Angeles, there were no less than three exhibitor organizations in that city.

He accomplished a triple amalgamation, working with the officers of the local, and merged the factions into a single group.

* * *

WITH no fanfare or ostentation, but with a quiet determination of purpose that is irresistible, similar work is being done in many other quarters of the field.

The effects of it are already beginning to be felt. The right note seems this time to have been struck.

Well may President Pearce and his associates confidently assert that the League is growing, and growing healthily. Healthy growth is permanent growth. The foundations of an enduring exhibitors’ organization are being built upon to good purpose.

The Boycott on Fake War Films

ONE of the best indications of the healthy condition of the motion picture industry, and the general attitude of those engaged in it—that the days of underhanded methods are passed—is seen in the welcome absence of fake war pictures.

Many extremely interesting views are shown each week on the various news pictorials, but it is seldom that any of these purport to show actual fighting. It is a comparatively easy matter to turn out fake fighting scenes.

In fact, it can be done so well that were ideals in the business as loose as they were some years ago this would be done constantly.

* * *

THE film industry is to be congratulated for this stand even more strongly in view of the actions of important newspapers. Only a few days ago a famous evening paper in New York printed a photograph of a Russian battleship which it reported sunk. It was shown immediately afterward that there was never any such a vessel in the Russian navy.

Besides this, nearly all of the papers are publishing views which the experienced eye can see are simply posed somewhere on the outskirts of the armies.

Photography is destined to play an important part in recording the history of this great war, but thousands of spurious pictures will have to be sorted from the genuine. It is a credit to the motion picture industry that it has supplied few or none of these falsified records.

Building a Christmas Issue

IN building the Christmas issue of MOTION PICTURE NEWS, it has been our aim to give an artistic issue to an industry in which the artistic rules.

Other trades, in which art production is much less or not at all a factor, are favored with journals often distinguished by pleasing color covers, inserts and pages. In particular, the advertising pages are illuminated by fine color schemes and layouts.

It would seem that the advertisers of quality pictures, above advertisers of almost any product, deserve and should have this decided advantage.

This is the idea back of the Christmas issue of MOTION PICTURE NEWS, dated December 19. It is a good idea and a laudable one; and we are pleased that the trade so regards it. It will be a notable issue.

CLEVER DOUBLE EXPOSURE IN "OUR MUTUAL GIRL"

An interesting bit of double exposure was recently performed in "Our Mutual Girl, No. 43," which has deviated somewhat from the paths of the former reels, inasmuch as Norma Phillips, who plays the part of Margaret, the Mutual Girl, admirably portrays two parts in this instalment.

The scenes are laid in an actual silk mill located in Paterson, N. J., and deals with a striking resemblance between Margaret and the factory forewoman. Margaret, when she discovers this resemblance, decides to uncover a plot laid to destroy the finances of her sweetheart.

The particularly interesting double exposures are when the forewoman, which is played by Margaret, passes in front of Margaret herself as the Mutual Girl, and this is considered the first time that a double exposure has ever been taken wherein a character passes over the line.

ENGAGE CAST FOR "ARE YOU A MASON?"

The Famous Players have gathered an important cast of Broadway favorites in support of John Barrymore in the forthcoming production, "Are You a Mason?" Leo Ditrichstein's successful farce. This cast includes Alfred Hickman, who created the original "Billy" in the stage presentation of this play, Charles Dixon, Charles Butler, Ida Waterman, Dodson Mitchell, Helen Freeman, Jean Acker, Lorraine Huling, Harold Lockwood, Kitty Baldwin.

OLDEST AMERICAN ACTOR IN WORLD FILM PHOTOPLAY

W. J. Ferguson, who appears in his original role of Pop Clarke in the photoplay version of "The Deep Purple," in which Clara Kimball is starring, under the direction of the World Film Corporation, has the honor of being the oldest American actor on the stage. He is the sole surviving member of the cast that supported Laura Keane at Ford's Theatre, Washington, the night President Lincoln was assassinated.

FAMOUS PLAYERS RE-ISSUE LOBBY BULLETINS

Upon the requests of many exhibitors throughout the country, the Famous Players Film Company have recontinued the publication and issue of the special lobby bulletins which were sent in advance of this company's releases last year. Beginning with the release of "The Conspiracy," exhibitors can again obtain these bulletins by sending a request to the Famous Players Film Company, or at their local exchanges.

GIVE YOURSELF A PRESENT THIS YEAR

of a year's subscription to
MOTION PICTURE NEWS
and start with the Christmas Issue,
the High Water Mark of Motion
Picture Journalism

Flamingo Prize Film Released December 20

"Without Hope," by Elaine Sterne, One of the Winners of the Chartered Theatres Contest, to Be Brought Out by Comedy Company

THE Flamingo Film Company announces dates for its first releases, beginning on December 20 with Elaine Sterne's comedy drama in four reels entitled "Without Hope." This comedy was awarded the second prize in the *Morning Telegraph* Chartered Theatres' Corporation National Scenario Contest, which closed September 15.

The dramatic features of the story are built around a conspiracy on the part of

in three reels entitled "Puritan Conscience," produced by Mr. Mace and practically the same company as seen in "Without Hope." The comedy will be released January 10. Miss Wells was awarded third prize in the scenario contest mentioned above.

Three weeks later Samuel C. Appleby's unique comedy drama entitled "The Sybil of the Film" will be released. This comedy was fourth in the contest, and it is believed will create a sensation. The producer is



SCENE FROM "WITHOUT HOPE" (Flamingo-Sawyer, Inc.)

spies employed by a foreign government to steal from the inventor his formula for noiseless gunpowder about to be tested by the United States government.

Fred Mace is the producer of "Without Hope," and surrounded himself with a notable company of players. Marguerite Loveridge, one of the best known players for the film drama, was specially engaged for the part of Hope. Mary Charleson, of Vitagraph fame, was given the important role of Irene, daughter of the inventor and sweetheart of the playwright, Van Alstyn. Both Miss Loveridge and Miss Charleson will be seen at their best advantage.

The advent of Catherine Proctor, famous as a Belasco star of many seasons in "Paid in Full," "The Easiest Way" and "The Governor's Lady," in each of which she played the leading part, into motion pictures, is made in "Without Hope." William Mandeville, Caroline Rankin, David Andrada, Johnny Doyle, Gertrude Barrett and Harry Kendall were entrusted with the other leads for the comedy in which 104 persons appear.

The settings of the comedy were all manufactured expressly for it. The exteriors, largely taken along the Hudson, present some magnificent views of the river and highlands, both by day and by night.

The second release under the Flamingo brand will be Carolyn Wells' farce comedy

Mr. David Miles, of Los Angeles, with a picked cast for its interpretation.

The February release of the Flamingo company will be Roy McCardell's satirical comedy, "A Jay in Peacock Alley," given first prize in the national scenario contest. Under Flamingo brand will shortly be announced a series of single reel comedies, extensive preparations for which are now under way.

D'ARCY LECTURES ON PHOTO MOTION

On Thanksgiving Eve H. A. D'Arcy, publicity man of the Lubin company, delivered a lecture to five hundred members of the National Commercial Gas Association at the Y. M. C. A. Building in Philadelphia. Mr. D'Arcy described "The Origin, the Evolution and Development of Photo Motion." The audience gave earnest attention to the speech and rewarded the reader with considerable applause.

After the lecture Mr. D'Arcy, by request, read his famous poem, "The Face Upon the Floor."

AUGUST AT BOSTON BALL

Edwin August, who is now being starred in features produced by the Kinetophote, attended the Exhibitors' Ball in Boston on December 2, as representative of the Kinetophote, accompanied by Hal August.

In and Out of Los Angeles Studios

Special to MOTION PICTURE NEWS

Los Angeles, Nov. 30.

HENRY WALTHALL, universally spoken of by members of the Los Angeles motion picture colony as one of the greatest dramatic actors of the celluloid drama, now in the East on a vacation of two months, has accepted an offer made him by E. D. and H. M. Horkheimer, owners of the Balboa Amusement Producing Company, at Long Beach, to appear exclusively in their features for a term of three years, and is to reach Los Angeles to take up his work there by December 15.

Mr. Walthall is to be starred in the Balboa features, according to the plans now being made, and will appear only in multiple reel features from copyrighted novels and well known successful plays, rights on which have been secured by this company.

Just now negotiations are being made for a director for the Walthall company and also a leading woman to play opposite him in some of the features. At this time the parties have been contracted, but owing to

ceived by the greatest men of the trade as masterpieces. Especially is this true of the latter named subject. Mr. Walthall's last work in Los Angeles was that of playing the lead part in the coming release "The Clansman."

As soon as the telegram accepting the terms of the Balboa owners was received,

man to escape from the Custer massacre, was begun the early part of last week by the Henry McRea company.

Bess Meredith is the cause of Murdock MacQuarrie making hurried changes recently. He played a character part in one and doubled in the juvenile lead parts of another one reeler produced by Charles Giblyn. In "The Last Performance" he was the hypnotist of a tank town wagon show when misfortunes caused the closing of the show at a time when the leading player's aged wife was dangerously ill. "The Fulfilling of the Law" is a drama with an unusual story, in which an invalid twin brother takes the place of the other twin being held for trial on the charge of murder, into which a pretty love story is woven and the cruelties heaped upon working girls depicted.

New Features of Rex Company

Five new features are promised in the two-reel subject, "The Game of Chess," being filmed by the Frank Lloyd Rex brand company, written by Ruth Ann Baldwin, from a suggestion of Publicity Man Bebee of the U studio, who spent five years with a Mexican government surveying corps. Gretchen Lederer plays the character part of a seniorita, and other members are Mark



E. D. HORKHEIMER

orders were given for the preparation of a special dressing room for Mr. Walthall. This will be made as comfortable and cozy as possible and fitted with all conveniences possible.

Isadore Bernstein, besides entertaining President Laemmle, reading all the company mail, giving the official O. K. to all acceptable scenarios, showing all finished pictures, superintending the construction of the new Universal City, keeping all fourteen companies working at the Hollywood studio, and the nine hundred and ninety-nine other matters pertaining to the management of the U. interests, has written a two-reel photoplay story, which has been put into scenario form by Bess Meredith, under the title "What a Woman Will Do."

In his play Cleo Madison is to be the woman, and the direction will be in charge of Wilfred Lucas. Joe King is the juvenile lead, Edward Sloman the heavy, and Ray Hanford is playing the character part.

Filming of "Custer's Last Scout," featuring Alfred L. Chapman, the only white



HENRY WALTHALL

B. Robbins, George Larkin and Helen Leslie.

"Lorenzo of Sorrento" is the title of the Italian story almost completed by the Sidney Ayers Powers brand company. In this the ambitious young Italian is first shown with his family in his native land. When he comes to America he soon learns the ways from his Americanized countrymen, and forgets about the wife and kiddies at home when he becomes infatuated with an



H. M. HORKHEIMER

previously made agreements they are to finish work in which they are engaged.

The contract with Mr. Walthall was made after four weeks of wiring back and forth across the continent. The exact terms of the instrument are not made known, but friends intimately in touch with the actor, who in fact served as his local representatives, state the salary is larger than that stipulated in any contract of Los Angeles photoplayers.

In Mr. Walthall's career in pictures he has been far more successful than on the stage, owing to opportunities. He was first featured in the big productions of an Eastern manufacturer. Among his greatest successes of the past year are the lead parts in "The Classmates," "Home Sweet Home," "The Gangsters" and "The Avenging Conscience," all of which have been re-

American girl. Finding all is not gold that glitters he returns to his own family, who have come in search of him.

The U comedy makers are all busy. Al Christie is making "When His Lordship Proposed"; Eddie Lyons, "For the Good of the Cause"; Allen Curtis, "Christmas Festivities"; and Jack Blystone, "All's Well That Ends Well," for Nestor and Joker release.

Calder Johnstone, scenario editor for "The Master Key," and incidentally chaperone for the company, arrived home the first of week from San Francisco, where exteriors for fifth, sixth and seventh episodes were made. From photographs replicas of interior scenes of the famous Maux hotel at the Golden Gate city have been built on the U stage and the players are now working at these sets.

At San Francisco scenes were taken at Golden Gate Park, the Japanese Gardens, the famous Cliff House, the beaches, Chinatown, and for a night scene the harbor commission lighted Fairy tower, and this in connection with Market street was taken at the same time.

It has been decided to make the "Campbells Are Coming," the picture of the East India war and incidents leading up to it of but four reels, and to release a week prior to this a two-reel picture introducing the characters and giving a prologue to the war features. The two-reel picture is being made under the title "The Curse of the

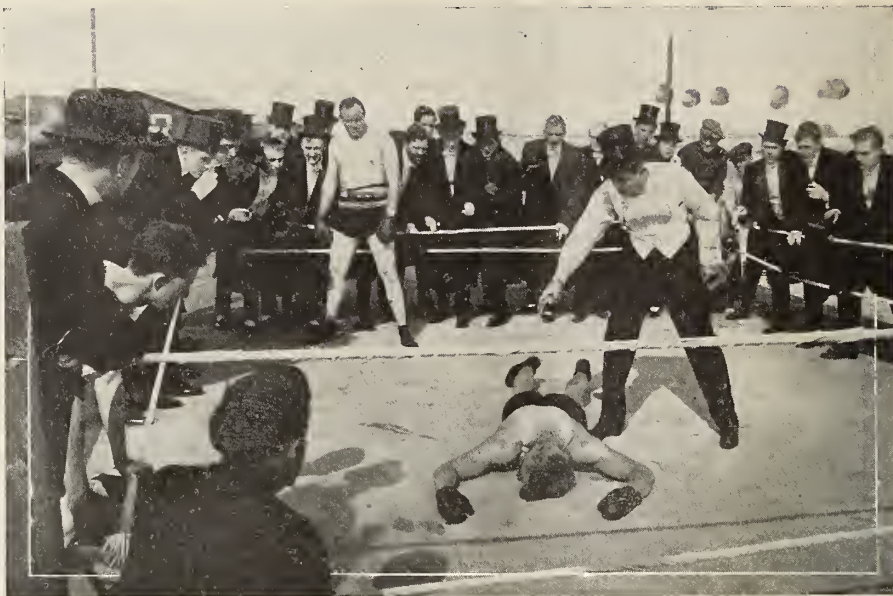

ONE OF THE "LITTLE JOKER'S" SOCIETY JOKES IN "THE TRUTH WAGON"
(Masterpiece-Alliance—December 21)

Chicago after spending four weeks at the coast studios, and witnessing the filming of many of the important scenes of "The Rosary." The last of the Irish village pictures were completed the first of last week and all members of the troop taking part believe the most wonderful pictures of Selig films have been made.

At Portuguese Bend the village was built back fully two miles from the ocean shore, on the tops of Malibu ranch hills, and in all the street scenes the ocean—two miles distant—will form the back ground. Just as the camera was ready to film a scene of the mother of Father Kelly waving goodbye to her son as he departed for America, a big ocean steamer hove into sight and added an additional feature to the scene as it majestically moved across the range of the camera. The Selig company has a number of goats, donkeys, pigs and other animals—no snakes—used in the Irish village scenes for sale.

Preparing for Rainy Season

General Manager Edmund Mitchell and players of the Climax company have completed filming the first production, "Lone Star Rush," and the photographic plant is now making the first print, which will have a private showing within the next few days. The laboratories are in charge of Gene Guissart and E. J. Sherman. The former was with the Melies company, and Mr. Sherman recently left the local Majestic studio.

Los Angeles studio managers are making preparations for the rainy season which is due most any time now. On the Lasky lot a glass-steel-concrete studio with floor space for a stage 60 x 60 feet is being built, and when completed will give the company a stage 60 x 160 feet. Other improvements made necessary by the addition of another company are two long rows of dressing rooms.

The Climax company, 1225 Lillian Way, is having plans made for a glass studio, and this will be completed by the first of the year.

The New York Motion Picture Company

studio at Santa Monica, the Keystone studio on Allessandro street, and the Sterling Motion Picture company studio in Hollywood have all been equipped with Winfield Kerner electric lights, which will make it possible to keep busy no matter how many clouds hide California's Old Sol.

Bosworth, Inc., is also building an additional stage made necessary by a third company, and will have the studio equipped for day and night work.

At the Majestic-Reliance studio two new buildings are being erected. One will contain about one hundred large dressing rooms and another is a two-story structure to be used as a work room for the carpenters and papier mache workers. The latter

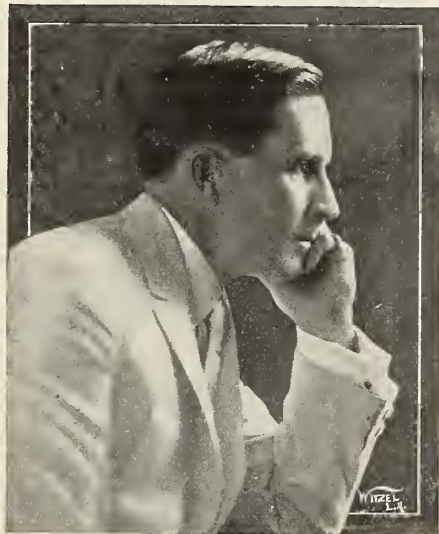

WILLIAM D. TAYLOR

Desert," by Francis Forde, while the massive sets for the four-reel picture are being completed.

Beranger Has Own Company

George A. Beranger, who for two years and a half has been assistant to D. W. Griffith, with the Biograph, and since with the Majestic, has been given a company, and this week began directing. His first picture will be a two-reel Majestic release, "The Baby's Ride," featuring Wallace Reid and Loretta Blake. This will show the experience of a two-year old, whom the parents believe has been kidnapped, but later is found amid pleasant scenes playing with other children.

Col. William M. Selig has returned to



HOBART BOSWORTH, GORDON GRIFFITH AND CHARLIE VAN LOAN

building is equipped with all kinds of machinery to be found in a saw or planing mill and is modern in every respect.

The first Smalley-Bosworth picture featuring Elsie Janis was completed last week, and has been named "The Caprices of Kitty." The story for this, by Miss Janis herself, gives the popular actress wonderful opportunity to display her talent. Some exceptional features have been introduced in this subject, which will reflect great credit on both Miss Janis and her director, Phillips Smalley, and no doubt prove one of the popular releases of the Paramount program. The company has taken up the

filming of the second picture, featuring Miss Janis. The story for this, like the first one, is by the actress, with scenario by Lois Weber (Mrs. Smalley).

Hobart Bosworth, who has been ill for four weeks, suffering with nervous prostration, is again at the studio, engaged in completing the four-reel picture from the Charles Van Loan Western story, "Buck-shot John."

Public Opening of Selig Zoo

Plans are now being made for the public opening of the Selig Jungle Zoo, the date of which has been set for January 1, at which time Col. William M. Selig will again come to Los Angeles to see that the event is properly exploited for the benefit of an appreciative public.

Director Tom Santschi and his company were filming last week a two-reel East India story written by James Oliver Curwood, "The Red Blood of Courage." The plot revolves about the kidnapping of an English girl by East Indians and her recovery. There will be a number of big scenes in this, for which special sets are being made. The leads are played by Bessie Eyton and Mr. Santschi.

A one-reel drama with an unusual twist is being made under the direction of E. A. Martin at the Selig Zoo. The working title of this is "The Prima Donna's Mother," and features Miss Marion Warren. The story is by Nellie Brown Duff, a scenario writer of considerable power.

"The Van Norton Diamonds" is the name of a two-reel gentleman crook and detective story being filmed by Frank J. Grandon for the Selig program. In this Franklin Hall plays the heavy, and the other leads are Lamar Johnstone and Edith Johnson.

A straight comedy, "The Lady Killer," which has an underlying thought, is being filmed under the direction of Norval MacGregor at the Selig studio. The title promises a treat for the public.

The second release of the Masterpiece company, "The Truth Wagon," a newspaper story, was completed last week. The release date has been fixed for December 21. The company will next film the modern novel "Jack Chanty," by a well known author, and scenario for this is now nearing completion in the office of Elliott Clawson.

Servant Problem Worked Out

The servant problem has received attention at the Majestic in the making of a one-reel picture, "The Better Way," under direction of Christy Cabanne. Dorothy Gish interprets the role of a servant girl, and Fred Turner is in his familiar character part of Father. In addition to giving light on the domestic help question, the picture will show the troubles of the young girl in reforming her parent, an ex-convict.

A very unusual mob scene was filmed by Donald Crisp, when he found he had but one more set to finish "His Lesson," a two-reeler for Majestic release. No 'xtras were to be found so he called all the heads of departments and everyone else at the studio in to take part. Included were F. E. Woods, scenario manager; Directors Griffith, Cabanne, Dillon, Mackley, Kelsey and O'Brien; three or four camera men.

including Billy Bitzner, who made his first appearance before the lens. Crisp is authority for the statement that every one of his mob belongs to the class known as "lens lice."

The picture story is one dealing with a young man of poverty, but with an ambition to rise that he may be in position to justify his asking the woman of his choice—surrounded by wealth—to become his

Picture company studio by Jay Hunt. The story is built around an Indian legend, and portrays the craftiness of an Indian chief, whose son breaks the father's promise by attacking the white settlers. When the chief discovers this he slays his son, and then to hide his disgrace, convinces the garrison at the fort that the son was shot by the Indians while he was protecting the paymaster. There are none to disprove the story.

The first picture to be completed under the direction of William S. Hart, recent addition to the New York studio directing force, is "The Passing of Two-Gun Hicks," in two reels. This may be classed as a character sketch of a particularly deadly type of gun fighters, now extinct in the West, in which the director plays the title role. A love interest is carried through the story. In the cast are Arthur Maude, Leons Hutton, and Barney Sherry, players suitably cast for the parts.

Inceville Studio's Fire Department

The Inceville studio now has a regular organized fire department and modern equipment of every necessary sort, with the exception of bells for the fire hose truck. Every Wednesday is fire drill day, and the laddies will have opportunity to show their ability in fighting flames when a dwelling house, now being built, will be lighted and burned for the making of a picture. When the camera stops, however, the members of the department have been advised, it will not mean that they may stop. Instead they must extinguish the fire.

Frank E. Woods is the author of "Rays of Sunshine," filmed last week by Director Jack O'Brien, and featuring Mary Alden, assisted by Jack Conway and Spottiswoode Aitken. The story deals with the ups and downs of an ex-convict railroaded to prison. Forced by an adventuress to rob the home of his employer, the ex-convict revolts at the last moment. This incident, staged in a new and thrilling manner, makes a very remarkable climax for this subject.



MARGARET THOMPSON

bride. In his early manhood days he turned away from his sweetheart because she was poor. When he is overtaken by misfortune, he is brought to realize the fickleness of society, and then learns his sweetheart, though plain, is true. Big George Seigmann, Billie West and Vester Pegg play the leading parts—except in the mob scenes. It is a story with a big idea, and will make people think.

"Last of the Line"

A military story, "The Last of the Line," is being filmed at the New York Motion



THE NEW POWERS-UNIVERSAL COMPANY AT THE WEST COAST STUDIOS

Sidney Ayres (standing, center), Tom Walsh (left, standing), Val Paul (right, sitting), Jane Bernandy (at right).

BOX OFFICE RELEASE A "BEST SELLER"

Victoria Cross, who wrote "Life's Shop Window," produced by William Fox's Box Office Attraction Company, in five reels, is also the author of "The Yoke" and "The Man's Law." "Life's Shop Window" and "The Yoke" won instant recognition. It made Victoria Cross an international figure.

It is asserted on good authority that these two "best sellers" ran up sales to 2,000,000 copies. Victoria Cross is a nom de plume; her real name is Harriet B. Rogers. Her publishers have instructions not to give out any information regarding her private life nor to publish photographs. It is generally known, however, that Miss Rogers is well connected in English social life and that she is the head of a private school for girls. She is very active in sociological work.

"CINDERELLA" TO BE FAMOUS PLAYERS XMAS RELEASE

When the Famous Players included in a recent announcement of forthcoming productions, Mary Pickford in a subject entitled, "The Stepsister," the company termed it "a genuine surprise." Just how much of a surprise it is, was recently disclosed when it was explained that "The Stepsister" is nothing else than a modern and original version of the century-old classic, "Cinderella." The subject is to appear on the Paramount Program December 28, and is described as the Paramount Christmas release.

GREAT NORTHERN RELEASES NEW "GAR EL HAMA" FILM

The Great Northern Film Company announces as its current release "The Adventures of Gar El Hama" in four parts. The picture is especially interesting in that its central character is one which figured in two former Great Northern releases about two years ago, at which time the hero attained great popularity.

Five Hundred Take Part In Wheat Pit Spectacle

THE WHEAT PIT SCENE FROM "THE PIT" (World Film)

THE biggest interior scene ever made anywhere was produced at the World Film studio at Fort Lee, New Jersey, on Saturday, November 28, by Director Maurice Tourneur. It was the board of trade scene in the Wilton Lackaye photoplay based on the great stage success, "The Pit."

Five hundred men took part in the picture, and Director Tourneur secured the services of sixty brokers from Wall street, the New street curb, the Consolidated Exchange and the New York Stock Exchange. These brokers were under the direction of P. C. Mullen, 51 Exchange street.

Several of the brokers had bought and sold wheat in the very pit which was being reproduced for the camera in the pit

scenes. Forty Western Union and Postal messenger boys were used to add to the realism of the settings.

Wilton Lackaye recently made a special trip to Chicago and took special scenes on the floor of the famous wheat pit there, in order to obtain the exact atmosphere for the spectacle.

"FALSE COLORS" MAKES TRUE PICTURE OF LIFE

A forthcoming Bosworth release through the Paramount Corporation, entitled "False Colors," written by Lois Weber and produced by Lois Weber and Phillips Smalley, contains an unusually constructed story, strong and sincere in its strength of plot and dramatic action.

"False Colors" is so named from the fact that practically every character of importance in the cast is laboring under false impressions of life. The story affords all the players an unlimited chance for the expression of human emotions. Similar to others of Miss Weber's conception the plot tends to teach a lesson; this one the uselessness of appearing under false colors before the world.

Miss Weber, who appears in a dual role, that of Mrs. Moore in love with the theatrical star Lloyd Phillips, and her daughter. Mr. Smalley is cast for the part of Phillips. Adele Farrington is said to be as good as ever in the role of the housekeeper. Courtenay Foote appears as the unprincipled son, and Herbert Standing is the playwright. Others in the cast are Charles Marriott, Dixie Carr, Roberta Hickman, Will Harrison, Fred Wilson and Marjorie Watt.

The camera work under the direction of Dal Clawson is said to be unusually excellent. One scene in particular, showing the interior of a theatre, is well photographed and effective.



THE PRINCE FITS CINDERELLA'S FOOT TO THE SLIPPER
(Famous Players—Paramount Feature)

"THE SEATS OF THE MIGHTY"

(Colonial-World—Seven Reels)

REVIEWED BY PETER MILNE

SIR GILBERT PARKER'S novel, "The Seats of the Mighty," as adapted for the screen, forms a picture which, according to the standard of historical productions, is far out of the ordinary. In the first place, instead of being mainly historical, with a group of long since forgotten political personages continually in the foreground, it is mainly a story. And in the second place it is a story of the most thrilling variety with a plot often seen nowadays but doubtless quite original at the time of its creation. Handled as it is, it retains all its power.

Unavoidable difficulties are always present in a picture laid in another time, more especially when it is historical in nature, but they have been overcome by the producer of "The Seats of the Mighty." The great number of characters introduced in the first reel is slightly confusing, the more so because their wearing ap-



THE END OF ALIXE'S DANCE BEFORE BIGOT

parel is almost alike. But after the main story has gained headway, which it does soon after the beginning of the second reel, the characters are straightened out in the minds of the spectators, their exact place in the story becomes obvious; and after this they are seen so often that even if their costumes are similar they are no more confusing.

While on the subject of costumes, it may be remarked that they are gorgeous, correct in every detail, and worn with a grace and ease by the players that never betray their true selves nor the actual period in which they live.

The settings, whether they be magnificent or lowly, as the case may demand, deserve praise for the same reasons. In these respects and again in the movements of the players, the entire film will call for none but unstinted commendation.

An exceptionally large cast appears. The three principals are Lionel Barrymore, who gives an excellent account of himself in the role of Monsieur Doltaire, the grasping and greedy lieutenant of Louis XV in the French Canadian possessions. Millicent Evans plays the part of Alixe Duvarney, the girl whom Doltaire desires. She is the figure that attracts most attention as the story progresses. Glen White, who has the role of Robert Moray, the hero of the tale that receives the true affections of the girl, neglects none of the excellent opportunities that have been provided him to exercise his ability.

When Moray is made prisoner by the villainous Doltaire, and from then on until he is released, due to the capture of Quebec by the English, whole hearted interest is maintained. The situations that appear are powerful, well constructed, and procure and retain a powerful grip on the spectator.

The fascination of the story of course is mostly due to the unceasing efforts of T. Hayes Hunter, the director. He had a hard task allotted him, to cause the story to be interesting and not dry and meaningless, and he has accomplished it in excellent style.

Photographically the picture is good, too. A little more tinting here and there would do no harm, but this may be attended to. The picture was shown at the Casino Theatre, New York, during the week of November 29.

"THE LITTLE REBEL"

(Gauntier-Warners—Two Reels)

REVIEWED BY PETER MILNE

A DRAMA concerning our own war between the North and the South will, no doubt, appeal to all classes of people for many years to come. Such a subject is one of those which never grows tiresome, and so, unless the feelings and sympathies of the public have changed over night, "The Little Rebel" is bound to be a success. One gratifying thing about it is that it isn't a production of greater length. Directors often think that as long as the picture in hand concerns the Civil War they are licensed to string it out over a great amount of space, and by so doing the charm of the story is lost.

"The Little Rebel" is just the right length. It is interesting throughout the entire two reels; furthermore, it is not wholly a drama. True, the story is largely serious, but there have been some excellent comedy moments injected into the main plot which go a long way in maintaining the interest.

As for the acting, the Gene Gauntier players have always offered us excellent work. Gene Gauntier herself heads the list and reappears on the celluloid after a prolonged absence in the countries now at war on the other side of the water. Her part is that of a Southern girl, who is the daughter of a Southern commander, and what is more to the point, in love with a Northern soldier. Jack J. Clark is the Northerner, and a fine, daring, reckless soldier he makes. He is sent to spy on the Southern fortifications and is only rescued by his sweetheart, who dresses him as a colored mammy and so takes him through the lines. Arthur Donaldson is a fine Southern colonel. The picture was produced by Sid Olcott.

No scenes of battle appear until near the end. The scenes are not too long then, but short and terrific and most realistic. The fight of the opposing forces on the stairs at only sword's length is most thrilling, and well staged.

The story ends happily for all concerned. As a whole "The Little Rebel" is sure to please.

"THE BELOVED ADVENTURER"

(Lubin—Thirteenth Episode)

THE series of "The Beloved Adventurer" is drawing to a close, but still Lord Cecil is kept busy with opportunities to show his cool courage and to grasp the most exciting situations with good results. In this number, "Through Desperate Hazards," his nerve is taxed to the limit. Aside from his own affair in rescuing his wife, he is drawn into a romance in which he has no concern except that he must take part in the interest of right. In this story he and his wife are rescued from a burning ship, and the



IN THE SUMMER HOUSE

arch villain, Carson, meets his end in a fair fight with the heroic Englishman.

The picture is one of the best and very dramatic, and will make many picture fans sorry that only two more numbers remain to tell of the romances of "The Beloved Adventurer."

Emmett Campbell Hall's book has been faithfully illustrated in the Lubin pictures.

"Decidedly Distinctive"



KRITERION SERVICE

INTRODUCING
SOME OF OUR
TALENT



HELEN K. FRENCH
NAVAJO



J.L. PHIPPS
ROBBIN



DOROTHY DAVENPORT
PARAGON



ALLAN FRALICK
THISTLE



MARY RUBY
ROBBIN

A PROGRAMME REPLETE WITH FAVORITES

PROGRAMME
EVERY DAY A COMEDY
EVERY DAY A DRAMA
EVERY DAY A SPECIAL
EVERY SUNDAY
A KRITERION SUBJECT

CAST :-
ROBBIN..... COMEDY
PARAGON..... DRAMA
THISTLE..... COMEDY
NAVAJO..... DRAMA
SANTA BARBARA..... COMEDY
SANTA BARBARA..... DRAMA
ALHAMBRA..... COMEDY
ALHAMBRA..... DRAMA
PUNCH..... COMEDY
TRUMPS..... DRAMA
NOLEGE..... SCIENTIFIC & EDUCATIONAL

You will be proud of the Kriterion

IF

YOU are perfectly satisfied with the business you are now getting, the next page will not interest you.

MICA FILM CORPORATION

Temporary Headquarters, 222 West 42nd Street

Permanent Offices, 1600 Broadway, 6th Floor

NEW YORK CITY

Be sure to mention "MOTION PICTURE NEWS" when writing to advertisers.



You have heard some exhibitors say:

"Oh, I guess I am getting my share of the business in my town."

Was it you who said it? Well, never mind, if you are only getting your share you ought to be ashamed of yourself. The Kriterion Program demands and will bring the business of your town to your theatre. It has the quality, it has the service, it has the price, it is just what you have been waiting for. In other words we mean:

WE WORK WITH YOU YOU WORK WITH US

THIS SPELLS CO-OPERATION, the greatest business asset in the world today.

The good book *says*:—"He who hesitates is," but get in touch with our *nearest exchange* to be *convinced* of this fact or cannot we see you *personally* in our own *headquarters*? Those who have seen our film are *enthused* over our program. *You* can now see our product for *yourself* and know what we mean when we say that the *Kriterion Program* is "*Decidedly Distinctive.*" Our *latch-key* is always hanging out for you—**USE IT.**

This is *not* a program on paper,
it is a program on film.



"ZUDORA"

(Thanouser—Third Episode)

REVIEWED BY PETER MILNE

IF the succeeding seventeen problems allotted to "Zudora" to solve by Hassam Ali become any more complicated than those he has given her already, she will be more than worthy the right to marry Storm when she has emerged from all of them successfully.

Although we don't desire to slander any denizens of the law, it might be remarked in passing that the two tangles already straightened out by the beautiful heroine of the story would baffle even our foremost detectives and secret service agents. At any rate, the solution of the problems are so well concealed by the producers of the picture that no inkling of the most minute sort is given as to the outcome.

Much of the credit for this should go to Frank Sullivan. Of course, the situations were conceived by the writer, Daniel Carson Goodman, but brilliant situations would be utterly spoiled if the director was not competent and well versed in his art. To put a picture on and conceal its termination is no easy proposition, and it is therefore to Mr. Sullivan that a great amount of praise should go.

Regarding the story of this separate episode, it concerns cheese and diamonds, being entitled "The Mystery of the Dutch Cheese Maker." The cheese maker has the misfortune to own a store directly above the office of a diamond manufacturer. Storm frequents this store, on numerous occasions, purchasing various brands of cheese which he carries home, there partaking of a midnight feast, perhaps with crackers and milk on the side.

Hassam Ali is in league with the diamond maker, who one day finds that his diamonds are mysteriously vanishing from a sealed closet. The two are unable to find the thief. But "Zudora," who finds her way into the den, discovers that a



HASSAM ALI SHADOWS THE LOVERS

group of mice are the culprits. The mice dine on cheese in the store above, and then neglecting to wipe their noses descend to the closet in which are the diamonds. The diamonds on being smelt firmly adhere to the noses of the mice, who carry them upstairs and in partaking of more Limburger lose them in their repast.

Storm, the cheese maker and his entire family are imprisoned as thieves, until this fact is made known to the police by Zudora. It surely was a deep mystery to solve, as one would never think of associating cheese and mice with diamonds, but such was the case, and Zudora was the person who discovered it. Therefore all the more credit to her. The succeeding mysteries may seem deep and unfathomable, but they can hardly surpass "The Mystery of the Dutch Cheese Maker."

NELSON JOINS UNITED FILM SERVICE

THE Nelson Film Corporation is the latest concern to become affiliated with the United Motion Picture Producers, Inc., which was formed recently to furnish the daily service to the United Film Service (Warner's Features, Inc.).

"THE MASTER KEY"

(Universal Special—Second Episode)

REVIEWED BY PETER MILNE

GR EAT things, just delicately hinted at in this episode, are in store for those who are to take "The Master Key" as a steady diet in the future. In the first two reels, the story gave the general appearance that it would be just the villain and the hero fighting it out without a great bit of outside interference.

But here we are given to understand that a mysterious woman, one without a past, or more probably one that she doesn't care to publish, and a youth who was Dore's rival in college, are behind the man, Wilkerson, the former partner of Gallon, who is bent on taking revenge on him.



DORE SAVES THE MINER'S LIFE

Alan Forrest is Drake, the young man and Gene Hathaway, the woman. Aside from these two no other characters of importance are introduced into the story. When Wilkerson finally succeeds in locating Gallon he joyfully communicates the good news to Mlle. Darnell, and after that he retreats from the limelight for the time being.

Gallon, who it has been narrated, is always in deadly fear of the return of Wilkerson, is terribly shocked when he does appear, and accosts him on the step of his house. He sinks down in fear and buries his face in his hands. Dore and his daughter Ruth seeing him and not the other man, as he has disappeared, run to his side, and when he looks up he sees Dore standing where Wilkerson was before, and his natural conclusion is that he has seen a vision, as the poor man is often affected that way.

The big scene in this chapter comes in the latter reel, when Dore, who is taking a ride in a car that runs on a wire, saves Ruth from a runaway scuttle running on the track beneath. Dore hangs on the edge of the car by his knees and pulls the girl out with his hands. The car in which she was riding runs on and plunges off the end of the track. This is an excellent thriller, and all praise should go to Robert Leonard and Ella Hall, the only two who were concerned in it.

Although not as yet showing any indications of eclipsing "The Trey o' Hearts" in the way of thrills, "The Master Key" gives great promise of equaling it. It contains a different sort of a story than its famed predecessor, one that consumes a greater amount of space in introducing the characters and getting under way. But now that these two things have been accomplished, it is about time that our greatest expectations concerning it be fulfilled.

ENGAGE CAST FOR DORO FILM

THE Famous Players Film Company has engaged a distinguished cast of Broadway performers to support Marie Doro in the film version of her greatest success, "The Morals of Marcus," by William J. Locke. This notable cast includes Eugene Ormond, who will appear in the role of Sir Marcus, and Julian L'Estrange, who will play the part of Pasquale, originally created by him in the stage production at His Majesty's Theatre in London.

CHARACTERISTIC SCENES FROM THE LUBIN EIGHT-REEL FEATURE "EAGLE'S NEST"



BLAISDEN REVEALS HIS IDENTITY

JACK DISCOVERS THE WHIP

THE REAL MURDERER REVEALED

"EAGLE'S NEST"

(Lubin—Eight Reels)

REVIEWED BY PETER MILNE

EIGHT-REEL pictures are often steered clear of, owing to the general supposition that they could have been told in half the length. "Eagle's Nest," an eight-reel subject, could hardly be condensed, as it stands now; there is not a tiring or heavy moment in it. You may question this, as praise has been meted out so liberally of late that it has lost some of its force; an "excellent" picture means only an "average" picture, perhaps. But when we say that this production is excellent, we mean excellent in all the senses of the word.

Adapted from the old stage play of the same name, "Eagle's Nest" is essentially a melodrama, but not melodrama of the exaggerated "blood and thunder" variety. It may have been this sort of a play on the stage, but on the screen, combined with the beautiful and magnificent backgrounds, and these supported by perfectly clear photography, the entire aspect of the picture undergoes a change.

Melodramatic sentences when mouthed by actors on the stage do, generally, seem insincere and grossly exaggerated, overspoken and bad. When we read the lines ourselves in a book they seem better, and when we see screen characters interpreting the lines by concise actions, facial expression and the like, it is even better yet. In other words, all the faults that are present in stage melodrama disappear when the production is handled skilfully on the screen.

In regard to the photography, no room is left for any sort of improvement. Artistic scenes, some of them filmed in "The Garden of the Gods" of Colorado, offer themselves as such beautiful backgrounds to the story, yet do not eclipse the action, that scenically there is no cause for any unfavorable comment. One scene in particular, taken at a great altitude, shows a ridge of light clouds beyond the tops of the mountains, an effect only obtained after the greatest trouble.

Romaine Fielding directed the picture, and was assisted by Harry Chandlee in adapting it from the play, besides playing the heavy of the cast. Taking every side of the picture into consideration, one cannot help but extend to Mr. Fielding the heartiest praise and thanks for the obvious success he has attained in his efforts. In the part of Blaisden, the heavy of the story, the one who causes all the trouble by desiring a girl's hand who does not desire his, Mr. Fielding seems to be as villainous a villain as one could wish for.

Edwin Arden, who played in the original production as Jack Trail, the western lover of the girl, has the same part. Although slightly old for the part of a young man, this fact is hardly obvious on the film, as the scenes have been carefully arranged, causing him to appear to the best advantage.

When we stop to consider that the picture is eight reels, which, by the way, is the first picture of that length that the Lubin company has turned out, when the supporting cast was almost totally uninitiated in the art of photoplay technique, when so many unseasoned extras were employed, the excellent results achieved warrant extensive commendation. There are punches, too, a most realistic fight between Indians and immigrants occurs in the end, which further our opinion that the picture will make a big impression.

"THE END OF THE BRIDGE"

(Balboa-Box Office—Three Reels)

REVIEWED BY PETER MILNE

THERE is always something engaging about a story concerning the ways and methods of a band of crooks, all the more so when a detective is after them. These three reels, crammed full of action, make the time fly so quickly that the picture will seem all too short.

One very thrilling event is pictured toward the end of the last reel, when two of the principals of the cast start across a railroad drawbridge on a hand car. When they are almost at the middle, the bridge is raised by their pursuers, and, luckily enough, the car balances on the end. The man runs back, gets the best of his enemies, and lowers the drawbridge and then the two proceed on their way.

The story relates how a detective on the track of a band of thieves, smugglers and other criminals disguises himself as a stevedore, discovers that one of their number desires to reform, and after rounding the others up he saves him and marries his sister.



DAVID PREVENTS A CATASTROPHE

The scenes on the wharf and about the mud flats are the real thing and are of course as realistic as one could wish. The men who play the parts of the crooks have obviously spared no pains in making themselves appear just as a crook should.

There are fights galore; one takes place between the detective and a crook in the water, others are staged on the mud flats, and for the reason that the participants don't mind at all about falling in the mud and apparently delivering solid and hearty blows on the bodies of their opponents, seem more sensational, more thrilling and more realistic.

Those in the cast that carry the principal parts are J. Francis McDonald, who is the detective; Madeline Pardee as the girl, and Fred Whitman as the crook brother of the girl.

"MRS. BLACK IS BACK"

(Famous Players-Paramount—Four Reels)

REVIEWED BY PETER MILNE

FOUR reels of clean, wholesome, sidesplitting comedy, with a plot linking the laughs together, is what "Mrs. Black is Back" offers to the exhibitor. From almost the very first scene until the very last, anyone who watches the performances rendered by the players will indulge in laughter, loud and long.

May Irwin appears in the title role of Mrs. Black, who before she becomes the wife of Professor Black, tells him that her age is twenty-nine instead of thirty-six. She also informs him that her son Jack is ten, whereas he is really flirting around the latter 'teens.

When she is married she finds herself in a great fix, one lie leads to another, and every minute she finds herself in water a great deal deeper than what she cares for. At length after her son on his arrival home has assumed the guise of cook for a time, and when he is seen making love to his valet, whom Mrs. Black informed her husband was the mate of a mythical Aunt Prue, the truth comes out.

Then follows a chase to bring Mrs. Black back, and back she is brought, after having the experience of being blown up in her Ford car. The Professor laughs the whole thing off, and a real family reunion follows.

All the scenes of the picture lead up to the comical climax of the Professor discovering his wife's deception. They are as funny as one could wish, and never in the least tiresome. When the Professor brings home toys for Little Johnnie, as he calls him, and again when Mrs. Black passes her son off as the gasman, and later on dresses him up as cook of the establishment, no one will be able to resist breaking into the heartiest laughter.



DECORATING JACK AS THE NEW COOK

Scenically the picture is excellent. The exteriors were taken on the estate of Miss Irwin on the St. Lawrence River. The interiors are up to Famous Players standard, and all the scenes are supported by excellent photography.

Others besides May Irwin in the cast are Charles Lane, who carries the part of the Professor; Elmer Booth as son John, Marie Pavis as his fiancee and Clara Blandick, Wellington A. Playter, James Hester and Cyril Chadwick appear in the remaining parts. The cast is remarkably well balanced, in fact, the entire picture should prove as great a success as the play scored while on the stage.

"IN THE NAME OF THE PRINCE OF PEACE"

(Dyreda-World—Four Reels)

REVIEWED BY PETER MILNE

THERE is one thing that most persons will be glad to hear of in connection with this picture. The director, J. Searle Dawley, has departed from the practice of introducing men obviously dressed in uniform of the warring countries in Europe. It would

be insanity to try to pass them off as if belonging to some imaginary country.

The story presented is one of great interest after the first reel, which contains a rather unnecessary but unconventional introduction.

This is the second appeal for peace coming from the Dyreda studio, and if to be peaceful we have to see the horrible results of war, results which we don't like to think of, "In the Name of the Prince of Peace" will make its mark. The story is strong and



UNMOVED BY THE PRIEST'S APPEALS

no fault can be found in its production. The battle scenes are terribly realistic, and the last one brings the tragedy of the film to a close with two of the members of the once happy family dead, and the other, the brother, who was insane before the outset of the war, unmentioned and unaccounted for in the finale.

NEW PATHE SERIAL WITH SAME CAST

IT is announced that with the ending of "The Perils of Pauline," Pathe will release another serial with substantially the same cast, but showing adventures of a different sort.

The remarkable success of the "Perils" has been the cause of many requests from the exhibitors for another Pathe serial with the same "punches" that have characterized the last.

PRODUCTION AT STANDSTILL IN EUROPE

NEYROUD & SONS, Regent House, Kingsway, London, W. C., British agents for MOTION PICTURE NEWS, report that there is a dearth of films in Italy, Denmark, Spain and Russia. In Spain and Russia the local producers have shut down; "every thing points to the fact their 'back numbers' could be disposed of to a decided advantage, as the houses still fill well."

THE CENSORSHIP SITUATION IN OHIO

(Continued from page 29)

"They do not know—never reading the papers—that Judge Sanders discharged the writer last September when I refused to use the leaders in order to test the law and that Judge Lowe discharged Ralph Fitzwater, of the Cozy theatre at Lorain, Ohio, last week for the same thing.

"The average exhibitor stands in fear and trembling of the awful censor and the police who have been 'egged on' to get after the showmen and film men.

"The men who represent the 'censor group' are received smilingly and graciously at the film offices, as befits their exalted and important positions.

"When they leave the atmosphere is blue with profanity. "I have seen it and know whereof I speak. Now it is up to the New York producers to finance the legitimate work necessary to repeal the cause of all this.

"Exhibitors are in no mood to be bamboozled any longer. Film service has already taken an upward jump and I am stating publicly what all exhibitors hereabouts are grumbling about and protesting against privately.

(Signed) "SAM BULLOCK, Cleveland, Ohio."

NUNS AND CHILDREN VISIT AMERICAN STUDIO

TWELVE nuns and more than one hundred children from the St. Vincent school at Santa Barbara, Cal., were guests at the American studio November 25, where they saw pictures made, developed and projected. But few of the children had ever before seen a motion picture, and it was the first time any of the Sisters had viewed pictures or seen them made.

The film shown was "Beppo," made under the direction of Henry Otto, and in which two children—twins—play an important part.

"FANTASMA"

(Edison—Five Reels)

REVIEWED BY CLIFFORD H. PANGBURN

A DECIDED departure from the usual thing in motion pictures is provided in this offering. It is founded on the stage spectacle of the same name put on by Hanlon Brothers, and presents George Hanlon, Jr., in the role of Pico, the clown. In addition to his work in the picture Mr. Hanlon prepared the film version from the original.

However cynical and practical people may be nowadays, the fact remains that nearly everyone likes a fairy story. Although they are generally supposed to be of interest only to children, grown-ups always enjoy a good one even if they will not admit it. "Fantasma" is more than a fairy story. It introduces all the delightful features of the Hans Christian Andersen tales, including the prince and his sweetheart, the princess, the queen of the fairies, the devil and some of his assistants and animals which talk.

In addition to this there is a number of excellent touches of humor, well calculated to keep the audience laughing. Altogether it is a picture which will furnish endless delight to children, and at the same time give their elders a welcome relief from the battle, murder and sudden death which they are so accustomed to see on the screen.

The scenic effects are deserving of special mention. Those which are entirely natural are of an unusual beauty, as they are

Marie La Manna is seen as Princess Lena, and Edwin Clark as her royal lover. George Hanlon, Jr., as mentioned above, keeps everyone in good humor by his antics as the clown. Others in



PRINCESS LENA AND HER SWEETHEART

the cast are William Carlton, George Schrode, William Ruge, Grace Goodall, Richard Neill, Mathide Baring and William Fables.

"DAMON AND PYTHIAS"

(Universal Six Reel Special Feature)

THERE are many things essential to the success of a feature film. The majority of them will be found in "Damon and Pythias," the six reel special produced by the Universal Film Manufacturing Company. Human interest, thrills, novelties, and a moral make an ideal combination on the screen.

The picture was given its premier at the New York Theatre on Monday night. An audience that taxed the capacity of the house greeted the first public showing of the production.

Primarily its chief interest is for members of the Knights of Pythias. The story gives in detail the ritualistic theme of the order. To the general public it presents a theme of good heart interest, well garnished with the spectacular and unusual.

The first of the six reels is given to views of Athens and Greece, which succeeds in creating an atmosphere befitting the production. The story is slightly vague for the first reel. This in part may be due to introductory scenes showing the principals in modern dress, with the difficulty of penetrating disguises and makeups and establishing identities while story names are being committed to memory.

Damon, a senator and one of the governors of the city of Syracuse, is opposed by Dionysius, its chief of generals, who covets the throne. Pythias, the soldier, is a favorite of Dionysius. Damon, the senator, and Pythias, the soldier, are friends. Their attachment for each other is famed in the city.

Dionysius meets Calanthe, daughter of Arria and affianced of Pythias. Her charms attract him, and he sends Pythias to Agrigentum with a body of soldiery to aid in defending that city against the Carthaginians, feeling certain that the young warrior will be killed in battle. But he returns victorious, and Syracuse bestows a wonderful welcome. On the fete day Dionysius pits him against Aristotle, the champion of charioteers in Sicily. Again Pythias is victorious, and his popularity with the masses trebles. Dionysius then conspires to obtain the throne.

On the day of the wedding of Pythias and Calanthe, the senators in secret conclave elect Dionysius king. Damon denounces him as a traitor and attempts to kill him, and is sentenced to die. Pythias in the midst of the wedding festivities hastens to Damon's side, and gives himself as hostage while Damon goes to bid farewell to his wife and son.

His return after many delays is fraught with real heart interest. Dionysius, appalled by the depths of their friendship, pardons Damon.

Double exposures add much to the technical interest in the picture.



AT THE FAIRIES' POOL

the result of a careful selection of the most imposing spots about one of the finest estates in Connecticut.

The specially constructed settings are of corresponding excellence. These include the homes of Zamaliel, the prince of darkness, and of Fantasma, Queen of the Good and Light, as well as under the sea views. The mechanical effects introduced during the adventures of Pico in the haunted house are at once startling and funny, and to those unfamiliar with the technique of picture making will seem remarkable.

The story, insofar as there may be said to be any, concerns the adventures of Prince Arthur while in search of Princess Lena, his sweetheart, who has been carried off by Zamaliel. Fantasma sends the clown Pico to help the prince, and also gives him her own aid, even appearing in a mysterious flower bedecked chariot, which careful scrutiny shows to be one of the ubiquitous Fords.

INTERESTING FILM REVIEWS

PRODUCTIONS FROM ALL PROGRAMS

GENERAL FILM PROGRAM

"A Mother's Way." (Biograph. Mon., Nov. 30.)—A young man who has met with some success as a broker in a large city is ashamed of his mother's old-fashioned appearance and manner when she comes to the city to join him. She realizes his attitude, but instead of becoming bitter she secretly supplies him with funds from her small savings when he is in desperate need. A strong story well acted by a cast headed by Kate Brice.

"The Closing Web." (Biograph. Two reels. Tues., Dec. 1.)—In order to get money to help her father a girl becomes the accomplice of a gambler. Later she falls in love with one of their intended victims, and leaves the gambler to marry him. Her husband supposes the crook to be her father, while her own father thinks she is married to the man. After a number of years this mistake results in what is almost a tragedy. There is a good cast headed by Jack Drumier, Louise Vale and Franklin Ritchie.

"The Girl of the Open Road." (Edison. Tues., Dec. 1.)—The second of the "Olives Opportunities" series, and is a pleasing number. The story deals with a gypsy girl who is an adept on the violin, and another girl and the man. It is a case of the eternal triangle, and the gypsy girl wins out by saving the man's life when he is about to drown. This number is replete with beautiful water and mountain scenes, and the clear photography makes them all the more evident. Directed by Richard Ridgley.

"A Double Elopement." (Edison. Wed., Dec. 2.)—A good comedy number. The young couple are surprised at the railroad station as they are about to elope, by the older couple intent upon the same proceeding. The final scene, where the two couples are seen seated on the rear platform of a speeding train is a fine example of what can be done by a good camera man.

"In Quest of a Story." (Biograph. Thurs., Dec. 3.)—In order to have some experiences on which to base a magazine article a girl disguises herself as a blind beggar and goes into a poor part of the city. There she meets a reporter who, ignorant of her identity, helps her in some charitable work. The pair are thus drawn together and a romance results. Gretchen Hartman and William Jefferson head the cast.

"Making Them Cough Up." (Biograph. Fri., Dec. 4.)—A split reel comedy introducing the familiar incident of a person who announces in a speedy restaurant that the man who is there with another man's wife will do well to leave unless he is looking for trouble. In this case they are invited to contribute to a reform cause. On the same reel with "Bertha, the Buttonhole Maker."

"Bertha, the Buttonhole Maker." (Biograph. Fri., Dec. 4.)—A burlesque in which the melodramas depicting the trials of factory girls are parodied with considerable effect. It is a split reel, being with "Making Them Cough Up." In the cast are Madge Kirby, Clarence Barr and Walter Coyle.

"Who Goes There?" (Edison. Two reels. Fri., Dec. 4.)—A rapid-fire comedy from the play of H. A. De Sauchet, in which one laugh-provoking situation follows the other in quick succession. On the screen it is funnier. There is not a dull moment in the entire two thousand feet, and the different impersonations of the young officer to help the love affairs of his two brother officers, culminating in his finally winning his own lady-love, by impersonating the aunt, are all cleverly worked out. The good photography, coupled with splendid acting of an exceptionally good cast, makes this an excellent comedy number. Directed by Ashley Miller.

"The Deacon's Son." (Biograph. Sat., Dec. 5.)—The deacon's son is a profligate, and the deacon himself a man of sanctimoniousness carried to an extreme. This is a combination which results in much trouble and a great amount of bitterness and suffering for all concerned. Lew Hart, Vivian Prescott and Hector Sarno head the cast.

"The Price of Silence." (Kalem. Two reels. Mon., Dec. 7.)—A dramatic story of business with a strong and unusual romance. Believing that a factory girl has had a part in a strike which has caused his financial ruin a young mill owner forces her to marry him as the price of silence concerning a murder committed by her father. His idea is to make her share his poverty. He soon meets with success and meantime falls in love with his wife. When father dies her former lover attempts to take her away, but he fails because she, too, has fallen in love with her faithful spouse. Alice Joyce plays the role of the factory girl with much effectiveness.

"The Moonshine Maid and the Man." (Vitagraph. Mon., Dec. 7.)—A touching tragedy of the highlands of the South. A girl tells her suitor that they must have some money to start life with, and that she will marry when he has \$1,000. He furnishes information concerning an illicit still to revenue officers in order to secure the sum. It turns out that the girl's father owns the place, and in the fight the young lover is mortally wounded. The girl forgives him as he dies. In the cast are Helen Gardner, Rex Hitchcock and Ned Finley.

"The Mystery of the Seven Chests." (Selig. Two reels. Mon., Dec. 7.)—A story concerning the strange adventures which took place in the pursuit of seven chests left in a storage warehouse by an ex-criminal. The chests are sold for storage charges, and are purchased by a wealthy young man who takes them on his yacht intending to open them for the amusement of his guests. The sister of the crook to whom they had belonged wants to get them because she is convinced that they contain articles of value, while a convict's daughter is just as anxious to obtain possession of them in order to establish the innocence of her father. After many remarkable experiences the last mentioned girl succeeds in opening the chests and finding evidence which leads to freedom for her father. In the cast are Edwin Wallock, Adda Gleason, C. C. Holland, Lillian Hayward, William Stowell and William Hutchinson.

"Crystals." (Edison. Mon., Dec. 7.)—An interesting split reel of a semi-educational nature. The formation of the characteristic crystals of a number of familiar chemical compounds is shown by means of micro-photography. The effects obtained are novel and beautiful.

"Through Desperate Hazards." (Lubin. Mon., Dec. 7.)—The thirteenth in the "Beloved Adventurer" series. Lord Cecil again meets with success in his own task through aiding someone else who is in distress. The master of a small schooner has stolen all of a poor woman's life-long savings. Lord Cecil happens to meet her and goes after the man. It turns out that his wife and her abductor are on the vessel. Then follows a duel, fire and rescue at sea, and general happiness. There are many good water scenes in the film. Arthur Johnson and Lottie Briscoe with the usual cast are seen.

"Sweedie and the Hypnotist." (Essanay. Mon., Dec. 7.)—A scrubwoman at a theatre falls asleep in her garden, and has a long dream in which she becomes a famous prima donna. She wakes to find that it is a stray goat which is receiving her caresses. Wallace Beery is seen as the scrubwoman.

"In Dutch." (Kalem. Tues., Dec. 8.)—A slapstick comedy based on the adventures of a man who attended a prize fight which was raided. He takes one of the men home with him where they have a hard time frustrating attacks by the sheriff and the man's wife. In the cast are John Brennan, Ethel Teare, Fred Hornby and Lee Hill.

BE SURE YOUR RELEASE DATES
ARE RIGHT—THEN GO AHEAD

YOU CAN ALWAYS BE SURE THEY ARE
RIGHT IF YOU GET

MOTION PICTURE NEWS

Five pages of every issue are devoted to nothing but release dates—the most complete and correct to be found anywhere. Comparison has proved it.

"Dobs at the Shore." (Lubin. Tues., Dec. 8.)—A wild series of rough and tumble scenes in which slapstick comedy is seen at its height. It is all started by a married man who tries to flirt with a girl at the beach. On the same reel is "He Made His Mark."

"He Made His Mark." (Lubin. Tues., Dec. 8.)—A comedy consisting largely of a series of beatings administered to a man who is too fond of kissing. The lesson taught is "the wages of kisses is kicks." On the same reel with "Dobs at the Shore."

"A Recent Confederate Victory." (Lubin. Two reels. Wed., Dec. 9.)—The plot of this drama is one which holds the interest closely. An old negro, now living in the North, goes back to Virginia where he finds his "Young Master" an old man in poverty, but still clinging to his estate. It is generally known that \$50,000 in bonds is concealed somewhere on the estate. The old negro knows where, and gets a mortgage shark to buy the place for a good figure by agreeing to tell where the bonds are hidden. He does so, but the bonds are Confederate. However, "Young Master" is happy.

"Sunshine and Shadows." (Vitagraph. Two reels. Tues., Dec. 8.)—The failure of jealousy in the face of true love is shown in this strong drama. A bank cashier is falsely accused of theft and leaves town. His fiancée throws him over. He meets and marries a girl, knowing that her past has been rather checkered. Later he is reinstated on the discovery of his innocence. His former sweetheart is bitter on learning of his marriage, and discovering his wife's past forces her to leave town under threats of exposure. The husband tells the girl his opinion of her and goes after his wife. Norma Talmadge and Gladden James head the cast.

"The Rose at the Door." (Edison. Tues., Dec. 8.)—The third of the series featuring Mabel Trunelle in "Olives Opportunities." A crooked relative of a wealthy man has hired assassins to kill the heir who stands between him and the fortune. A visitor in the house gets wind of the idea, and learns that the room of the victim is to be marked by a rose left at the hall door. She changes the rose to the door of the conspirator, who is seized, bound and taken away only to turn out the wrong man. Well acted and interesting.

"Saved by a Watch." (Selig. Tues., Dec. 8.)—A Tom Mix picture which includes a stage coach robbery and other diverting incidents. The hero is saved from death when a bullet strikes a watch in which he has the picture of the heroine. A Western story which is full of action.

"Mrs. Trenwith Comes Home." (Essanay. Tues., Dec. 8.)—A little girl is neglected by her parents. Her mother is a selfish society woman, and her father spends all his time looking after his business. The child's serious illness brings the parents to a realization of their faults and results in a change and a happy family life. In the cast are Helen Dunbar, Garda Holmes and John Coszar.

"The Fable of the Bush-League Lover Who Failed to Qualify." (Essanay. Wed., Dec. 9.)—One of George Ade's entertaining fables in slang. Homer Splits is far from being a lady-killer. Instead it almost kills him to talk to one of the frails. He tries a number of systems, only to fail and to rush from the house of his adored one on the appearance of her father. Moral: "It has to be done in just a certain way."

"A Matter of High Explosives." (Edison. Wed., Dec. 9.)—A chemist invents a new explosive. His wife becomes worried and walks in her sleep. Neighbors seeing her carry a bomb imagine it is filled with the new explosive and give her plenty of room. Her husband rescues her after she has climbed to the top of a telephone pole. The bomb is an empty one. Bess Milford and William Wadsworth are featured.

"The Athletic Family." (Vitagraph. Wed., Dec. 9.)—Pugilism is the fad in the Punchin family, and the father keeps everyone practicing the manly art, including his two daughters. One of the girls does not like her father's ideas and the other does. A number of funny complications follow the arrival of two suitors on the scene. The roles of Mr. and Mrs. Punchin are played by William Rea and Kate Price.

"The Mystery of the Yellow Sunbonnet." (Kalem. Two reels. Wed., Dec. 9.)—An adventuress who turns out to be a heroine is the leading figure of this excellent melodrama. Her part is played by Alice Hollister, with Harry Millarde as her sweetheart. The adventuress is aiding a foreign spy in an effort to steal some government plans from a naval officer. She falls in love with her intended victim, and repents sufficiently to save the papers and risk her life for the officer. Of course she marries the officer.

"The Abyss." (Selig. Wed., Dec. 9.)—A tragedy which points a moral by means of a story full of interest. A wealthy young man becomes infatuated with a girl, and the couple live together without the formality of a marriage. Both become addicted to drink. They go to the wilderness in an effort to throw off the habit, but there they meet death together. Thomas Santschi and Bessie Eytan are featured.

"Sophie's Sweetheart." (Essanay. Thurs., Dec. 10.)—Sophie's father announces her engagement to Mustang Pete, while her mother sends out a similar notice regarding Slippery Slim. Meantime Sophie goes off and marries a third man. A Western comedy of the regular series featuring Victor Potel and Margaret Joslin.

"The Man From the Sea." (Lubin. Two reels. Thurs., Dec. 10.)—A ghost story in which a dead man comes back to claim the girl who was stolen from him by a crook and murderer who posed as his friend. The two men had agreed to draw one poker hand, the winner to be left alone to court the girl. The crook cheats and later kills his rival. He keeps receiving wireless messages from the dead man to the effect that he will be with him on his wedding night. On that night the ghost appears, the girl is killed when her auto plunges into the sea, and the murderer commits suicide. The cast consists of Kempton Greene, Earl Metcalf and Anna Luther.

"Pure Gold." (Vitagraph. Wed., Dec. 10.)—This story introduces the favorite situation of a man who is bitter towards society, and particularly towards women, and has his whole character changed by contact with a woman of high ideals and noble spirit. The man is a miner, and the woman is a dancer from the nearby mining camp. Anne Schaefer and William Duncan play the difficult parts of the woman and the man.

"One Kiss." (Selig. Fri., Dec. 11.)—A farce comedy dealing with the way in which Col. Pippin finds himself tricked by his son and the son's sweetheart Trixy Bliss. The colonel is opposed to his son's marriage and cuts off his allowance. Trixy has a friend who runs a manicure establishment, and who induces the old gentleman to become so regular and attentive a patron of her place that he is forced to grant forgiveness as the price of silence.

"The Bold Banditti and the Rah Rah Boys." (Kalem. Fri., Dec. 11.)—An entertaining comedy in which some students plan a fake blackhand outrage at the same time that some real blackmailers start their work. Strange complications follow. The comedy nature of the film excuses the lack of proper college atmosphere. Lloyd Hamilton and Marshal Neilan are featured.

"On Moonshine Mountain." (Lubin. Fri., Dec. 11.)—A fast-moving melodrama of the Southern Mountains. A revenue officer and a reporter on a vacation become rivals for the hand of a mountain girl. The officer is so overcome by jealousy that he seeks to win out by calling the reporter a revenue officer. A hanging is narrowly averted. In the cast are Edgar Jones, Louise Huff, Robert Whittier and Tom Walsh.

"A Strand of Blond Hair." (Vitagraph. Thurs., Dec. 11.)—The comedy in this film is of a rather original nature. Bunny gets a lock of blond hair in his pocket as the result of a practical joker's prank. His wife sallies forth and tries to match the hair to that of all the blonds she meets, with surprising results, but no success. Later she comes upon Bunny actually in company with the blond in question, and there is almost a riot. Bunny is quite innocent and finally explains. Jay Dwiggin is seen as Bunny, with Flora Finch as his wife.

"The Stenographer." (Edison. Sat., Dec. 12.)—A girl needing money to care for her sick sister consents to take a place in the office of a rival of her employer, and act as a spy. She thus gets two salaries. She is suspected by the intended victim, and is given false information which leads to trouble for the other man. Ashamed of her course, especially when her new employer pays her much attention she confesses. He comforts her and tells her of his love. A simple but interesting story, which is well acted. Gertrude McCoy is seen in the title role.

"The Soul Mate." (Selig. Sat., Dec. 12.)—A foolish laundry girl believes in soul mates and as a result will not accept the honest attentions of a young man of her acquaintance. Also she narrowly misses serious trouble at the hands of an unscrupulous fellow. Finally she is informed forcibly of her foolishness, and finds happiness with her humble but worthy lover.

"Broncho Billy's Dad." (Essanay. Sat., Dec. 12.)—When Broncho Billy becomes sheriff his father tells him to do his duty no matter what happens. Later Billy has to arrest his own father for a shooting. It turns out that the old man fired in self defence, and that his victim is not fatally hurt. G. M. Anderson and the usual cast are featured.

"Sam and the Bully" and "The Fresh Air Cure." (Lubin. Sat., Dec. 12.)—Two slapstick comedies with the fast action usual in such production, and in the first-mentioned a rather effective plot.

"How to Do It and Why," or "Cutey at College." (Vitagraph. Two reels. Sat., Dec. 12.)—The first half of the title would have been sufficient as this picture has nothing to do with anything that suggests any college. It is, however, a fair piece of comedy. Cutey seeks financial support in some of his pleasures by making his uncle believe he is a serious investigator in the realms of spiritualism. When the uncle unexpectedly appears to attend one of his nephew's seances there is trouble right away and it lasts for some time. Wally Van, Cissy Fitzgerald, Harry Morey, Albert Roccardi, Alice Lake and Arthur Cozine are in the cast.

"The Flying Freight's Captive." (Kalem. Sat., Dec. 12.)—Another in the series depicting the "Hazards of Helen." Helen tracks the jewel thieves who had robbed the express messenger in the preceding story. He captures her and throws her into a freight car in which he is making his escape. She gets him unaware, and after wounding him jumps from the train and sends a wire ahead which leads to his capture. Helen Holmes is featured at the head of the usual cast.

UNIVERSAL PROGRAM

"The Empire of Illusion." (Victor. Two reels. Mon., Nov. 23.)—This is the second episode in the adventures of Terrence O'Rourke, Gentleman Adventurer, a part ably portrayed by J. Warren Kerrigan. In this he completes the feat he commenced in the first chapter. His mission takes him to the Sahara desert, where he is successful in saving the Princess' brother from establishing an empire, a wild idea that the boy has conceived at the instigation of the Princess' plotting husband. The Prince meets death in this chapter, and thereafter O'Rourke and the girl are free to love as they will. These two reels are full of excitement, there are battles, plots and all the other accompaniments of a thrilling tale.

"His New Job." (Sterling. Thurs., Nov. 26.)—This picture concerns for the most part a hotel mixup, in which the prominent figures are the new janitor, who creates havoc by brandishing a floor mop with amazing carelessness, two gentlemen much the worse for frequenting the bar, a waiter and a young lady. The gyrations of these persons are fairly funny, but not excruciatingly so. They might have a more humorous effect if they were less rough, and literally cleaner. The waiter, who appears seldom is the funniest and best comedian of the lot.

"The Girl Stage Driver." (Eclair. Two reels. Wed., Dec. 2.)—Virtually a one reel subject, and so it appears a little lengthy as two. A little too much escaping and recapturing occurs to sustain the interest. The scenes and photography, however, are faultless. Leaving out the introduction the girl stage driver is robbed of a bag of gold by two Mexicans. After a number of adventures the girl's sweetheart, the sheriff aided by the girl, herself succeed in making the two men captive. Edna Payne and Norbert Miles are the principals.

A GOOD RESOLUTION IS AS GOOD NOW AS IT WILL BE JANUARY 1—

Why not start your subscription in time to get

THE CHRISTMAS ISSUE OF MOTION PICTURE NEWS

Out December 19?

"Love, Luck and Candy." (Sterling. Thurs., Dec. 3.)—The actions of the principals of this reel are hampered by a plot that was assigned the back door some time since. The man poisons his sweetheart, then discovers she still loves him. In the end the poison turns out to be sugar. If we were permitted to suggest improvement, we might say a little less of the close-up, facial contortion idea. Max Asher seems to be the chief offender in this matter.

"The Higher Impulse." (Eclair. Sun., Dec. 6.)—Rather disagreeable, too much brutality and bloodshed. The reformation of an inebriate is only brought about after his wife and son have suffered terribly because of his craving for drink.

"Fido's Dramatic Career." (L. Ko. Sun., Dec. 6.)—A collection of well trained dogs, with a monkey, a goat, and a few other animals perform in this picture and will furnish great amusement.

"The Lion, the Man and the Lamb." (Rex. Two reels. Sun., Dec. 6.)—Dealing with the psychological development of man and produced in a telling manner by Joseph De Grasse. Pauline Bush, Lon Chaney and W. K. Wilson are well cast. In conclusion we are given to understand that stone age methods are about cast off, and that force is no longer a ruler. The director has fitted the remote past with the present in a fine way, and the two reels are always entertaining.

"The Inn of the Winged God." (Victor. Two reels. Mon., Dec. 7.)—Terrence O'Rourke appears in his third venture, and as it is along another line than the one which he completed in the last one, it forms a complete story, so that anyone will understand it, even though they have not seen the preceding chapters. At the request of Adolph Chamber, the legal advisor of the Princess, O'Rourke goes to the aid of another Princess, a character played by Gretchen Lederer. After helping her out of her difficulty she persuasively invites his love, and, being a care-free soul, Terrence is about to succumb to her charms when a vision of the other Princess arises before him, and, summoning all his strength, he refrains.

"Billy's Charge." (Sterling. Mon., Dec. 7.)—Billy the Sterling juvenile lead returns to the film after quite an absence. Those who appreciate the kid comedies will enjoy this. The whole thing might be more enjoyable if the baby, who is continually appearing, had less jam on its face, wore cleaner clothes, and again if the director had practised "swatting the fly" before filming the picture, as the flies that swarm over the characters, especially the baby, are not any too pleasant to see, nor are they exactly necessary in the story.

"Vivian's Cookies." (Crystal. Split reel. Tues., Dec. 8.)—On the same reel with "Whose Baby." This reel might appear laughable if handled by capable players, but in its own state it so far misses its intended mark that to call it a comedy would be little less than ridiculous. The wife of the nominee for judge bakes some cookies, into which a child pours some external application for rheumatism. When she presents the nominating committee with some of the cookies, and when they taste them, very naturally hubby loses his nomination.

"Whose Baby." (Crystal. Split reel. Tues., Dec. 8.)—On the same reel with "Vivian's Cookies." About on a par with its reel-mate in regard to funmaking qualities. The plot is not quite as good. To teach her nurse a lesson, the mistress steals her child. It is then stolen from her, and a great mixup ensues. Why the characters are so grotesquely made-up is beyond the imagination.

"The Widow's Last." (Nestor. Tues., Dec. 8.)—Murdoch MacQuarrie in a character portrayal supported by Helen Leslie. This time he plays the role of an old shoemaker, who is taken ill. The widow comes to his shop with the purpose of upbraiding him, but instead nurses him back to health.

"The District Attorney's Brother." (Gold Seal. Two reels. Tues., Dec. 8.)—The wierd tricks that the remarkable resemblance of two brothers played, ending with the death of one and his impersonation being carried off successfully by the other, are well portrayed here. Francis Ford directs the picture and plays the brothers. Grace Cunard appears opposite him. Several good double exposures appear, and some realistic fights are staged.

"The Genii of the Case." (Joker. Wed., Dec. 9.)—Ernest Shields again in a perfectly ridiculous picture, but very funny. He dreams and is transported back to some odd counties, perhaps in Egypt. The trick photography will afford much amusement. The picture is a laugh throughout.

"The Three Men Who Knew." (Imp. Two reels. Thurs., Dec. 10.)—Frank Crane, Alex-

ander Gaden and Edmund Mortimer are the three men; Dorothy Phillips is the former's wife. The story deals with the terrible revenge meted out to three men who ridiculed the gods of the Hindoos. One of them disappears, another dies from fright, and a third after killing his wife takes his own life. The acting is good. That the whole story is being read from a book comes as a surprise in the last scene.

"The Little Grey Home." (Victor. Two reels. Fri., Dec. 11.)—Harry Meyers, Rosemary Theby and Bransley Shaw play the leading parts. The playwright who has gained fame neglects his wife for the leading lady of the show (this part of the picture seems improbable as the two women are incomparable). Through the influence and actions of his friend he returns to his wife later. This will surely entertain.

"Adventures of the Nimble Dollar." (Powers. Fri., Dec. 11.)—An allegorical tale along totally different lines than others in pictures. The idea cannot be called original for it has been used heretofore on the stage. Pessimism, a black bandit, captures Dollar and Confidence, and so brings Panic to the town. Past Experience is consulted, and Confidence and its army soon kills Pessimist.

"The Trail Wreckers." (101 Bison. Two reels. Sat., Dec. 12.)—Acted by Henry MacRae's company with William Clifford, Sherman Bainbridge, Val Pal and Marie Walcamp in the cast. A regular rip-roaring western, containing plenty of action and a good lot of sensationalism of the most thrilling sort. Those who love western melodrama will find in this their hearts' desire.

MUTUAL PROGRAM

"His Taking Ways." (Keystone. Mon., Nov. 23.)—This film was seen without any semblance of subtitles, and was therefore rather incoherent, but the story is that of the rivals for the girl, two of them in number of which the most important is Chester Conklin. He is as funny as usual, and his queer actions will call for many outbursts of laughter.

"A Halted Career." (Keystone. Thurs., Nov. 26.)—Charles Murray is funnier than ever in the role of a painter, not an artist, but a non-union man, with a strong liking for alcoholic beverages. His profuse use of all kinds of paint while under the influence of many glasses of Scotch are humorous to a great degree. Toward the end of the picture he gets out on the scaffolding, and leaves his blow torch burning one of the ropes. Naturally the rope breaks and Murray is obliged to hang on to one strand, refusing to be rescued, and then falling down on the heads of the people below.

"The Hop Smugglers." (Reliance. Fri., Nov. 27.)—Irene Hunt appears in her familiar role of reporter. This time she is trying for a job, and is told to fathom the mystery of the hop smugglers. She does this with the aid of a secret service man in a manner which would be convincing, if we didn't see her fight three men for a considerable length of time before being worsted. But the picture will please; it is full of rapid action and numerous realistic fights are screened, with the characteristic fierceness of all Reliance physical encounters.

"A Corner in Hats." (Komic. Sun., Nov. 29.)—An excellent comedy of such a pleasing variety as this does not appear often. It is a little lengthy, perhaps, but people will heartily enjoy it, because it contains genuine humor. Tod Browning and Fay Tincher are the husband and wife. The wife has a bull dog presented her, which has a strong liking for men's head gear. He steals numerous hats and leaves them in the parlor, and hubby comes to the natural conclusion that his wife is carrying on numerous love affairs. The canine is a well trained animal, and adds a good bit of zest and life to the picture.

"The Old Good-for-Nothing." (Majestic. Tues., Dec. 1.)—An amusing comedy-drama most of which is devoted to the character portrayal rendered by Spottiswoode Aitken, who appears in the name part. Signe Auen is cast for the part of his loving piece. The Good-for-Nothing is an inventor who is pooh poohed by his sister and pitied by his niece. But his invention proves a success, and the young man who is engaged to the girl receives his invested money back tenfold. Aside from the fact that the photography is poor in places, this is a fine release.

"Cupid and a Dress Coat." (Beauty. Tues., Dec. 1.)—This is a most amusing and clean comedy which concerns two rivals, a girl, a ring and a dress suit coat ripped up the back. In the cast are Margarita Fischer, Harry Pollard and Joseph Harris. Some excellent sets and scenes have been chosen as backgrounds for the story, and the photography throughout the entire reel

is excellent. No slapstick tactics are resorted to for creating laughter. It is the story itself, even though conventional, and the hearty manner in which the players perform which will be responsible for the picture's success.

"The Strength o' Ten." (American. Wed., Dec. 2.)—This might be termed a temperance romance, laid midst the mountains. On the one side are ten men who imbibe frequently; on the other is one who drinks nothing but pure mountain water. He, however, proves more than the equal of the ten, when they come to thrash him for presuming to make love to the daughter of their leader. The one wins the girl and reforms the ten. William Garwood and Vivian Rich are the lovers. Gorgeous photography and beautiful scenes give the picture a decided artistic touch.

"The Lucky Shot." (Reliance. Wed., Dec. 2.)—A story concerning a desperate young man who goes west to earn money for his wife and child. He is intrusted with a large sum of money to carry to a bank, and is, of course, tempted, but a bandit's shot transforms him from a thief to a hero, and also knocks a piece of rock off a wall of sandstone wherein gold is found. An entertaining subject, slightly artificial, but played well. A slight atmosphere of socialism has been brought out by Arthur Mackley, the director.

"The City of Darkness." (Broncho. Two reels. Wed., Dec. 9.)—We are not very often honored with such a strong, powerful, gripping drama as "The City of Darkness." The one big situation which confronts the newly elected governor of the state, as to whether he shall save his brother from the electric chair by pardoning him when he has no ground on which to do so, or whether he shall let him die, despite the entreaties of his mother, is the one which is played up in a most powerful manner. Walter Edwards, who has a number of scenes to go through largely alone, proves himself a master of character acting in the role of the governor, his wonderful facial expression and his entire attitude convey the struggle that is taking place in his brain with remarkable strength. His successful attempt to save the boy comes only after the man whose evidence convicted him comes to gloat over the situation before the governor. He prevents his brother from dying by turning off the electric power of the whole city. Charles Ray gives a fine performance as the convicted man, and Herschel Mayall is good as the heavy. The production cannot help but be a great success; from the beginning to the end it is absorbingly tense, horrible at moments, but ending pleasantly.

"Not of the Flock." (Domino. Two reels. Thurs., Dec. 10.)—This is a vividly powerful drama depicting the reformation of the wild daughter of a saloon keeper, through the kind teachings of a broad-minded young minister, who, besides having the lawless girl to deal with has to overcome the bigotted and narrow minded prejudice of his own congregation. The situations that arise in the story are well built and carefully carried out by the principals of the cast. Charles Ray is well suited for the part of the young minister, and Enid Markey plays the role of the wild girl with force and ability. The film is entertaining throughout and teaches an excellent lesson.

WARNER'S FEATURES

"The Hello Girl of Angel Camp." (Premier.)—A thrilling western drama of the melodramatic type, with Fred Church, Edythe Sterling and Joe Franz in the respective roles of hero, heroine and heavy. The effect of anxiety that the train sweeping on toward the wounded girl lying across the tracks creates is almost terrifying. The Italian gardener, who, because he once rescued a young girl by stopping her runaway horse, believes that he has a right to love her. When he is soundly abused by the girl's lover he determines on revenge. But in the end he meets death, after he has wounded both the girl and her father. This one reel contains more action than is usually found in two, and will hold the attention from beginning to end.

"One on Charlie." (Superba.)—Rather an old idea is embodied in this comedy, but no doubt it will amuse some audiences. If the picture were shortened it would appear funnier. Charlie De Forrest in his usual comic role is in love with a woman who refuses him because he is poor. Charlie pays a man to kill him that night and soon after discovers he has inherited a fortune. Then follows a chase until the murderer at last captures Charlie and tells him the widow will have him after all.

"Through Shadows to Sunshine." (Mittenthal. Two reels.)—Devotees of the old fashioned melodrama may take pleasure in witnessing this production, if they are able to overlook the bad acting and direction. All the characters are the conventional melodramatic types, the villain and the heroine being the most important in the

cast. With educated persons the picture will pass as a farce. It may go better with the uneducated, although the faults are glaring.

WEEKLIES

"Hearst-Selig News Pictorial, No. 77." (Selig. Mon., Nov. 23.)—The throngs entering the stadium at Princeton to witness the football game between the Tigers and Yale is an interesting feature of this number. The scenes from the seat of war still occupy a good amount of space, and are as interesting as ever. An event which should arouse interest is the pictures of the delegates to the American Federation of Labor in Philadelphia. Preparing to feed the hungry on Thanksgiving Day brings the reel to a close.

"Hearst-Selig News Pictorial, No. 76." (Selig. Thurs., Nov. 19.)—The United States troops arrive at Paint Creek, Ark., to quiet the miners in that district; training police dogs at Mamaroneck, N. Y.; a picture of Chicago's mammoth pier which will extend a mile into Lake Michigan; the new Columbian military order for women on drill; members of the Salvation Army in Boston tear sterilized linen into bandages; the moving of the statue of General Sherman in New York to make way for the subway; scenes from California showing the manufacture of wine, and war news.

"Mutual Weekly, No. 100." (Thurs., Nov. 26.)—Forty-five thousand persons see Yale vanquish Princeton: the U. S. steamer *Tennessee*, which was fired upon by the Turks; the late Lord Roberts, England's commander, shortly before he died; Admiral Sir Christopher Craddock and his ship the *Good Hope*, which was sunk by Germans off the coast of Chile; illustrated dances, No. 3, the fox trot. Other war news besides a few more domestic happenings.

INCORPORATIONS

At Albany, N. Y.: THE INTERNATIONAL SCENARIO AUTHORS' CORPORATION. Deal in moving picture scenarios, plots, themes; to manufacture films, machines, etc.; to conduct theatre and amusement business; \$25,000; Manhattan. M. F. Bartling, C. S. McCullum and Arthur F. Pierce, Jr., New York.

PHOTO PLAYS PROPERTIES CORPORATION. To manage theatres and motion picture exhibitions; \$500,000; Brooklyn. Thomas A. Kennedy, Malvina Beyer and Clarence Britton, of Brooklyn.

ALLIED FILM DEALERS' INCORPORATED. General motion picture business; mountain ticket and tourist agencies; \$1,000; Manhattan. Harry O. Coughlin, Sidney A. Anderson and Jos. F. Curtain, of New York.

At Trenton, N. J.: THE LEXINGTON AMUSEMENT COMPANY. Total authorized capital stock is \$10,000, divided into 100 shares, valued at \$100 each. The amount with which the concern is starting business is \$1,200, subscribed by the following: Charles D. Cavanaugh, eight shares; Stephen J. Kelley, three shares; and David H. Burtz, one share.

At Dover, Del.: MASTERPEN MOTION PICTURE CORPORATION. New York City. Capital stock, \$500,000; to conduct places of amusement, dealing in films. Incorporators: Frank Hendrick, 347 Fifth avenue, New York; John T. McGovern and Harry K. Karst, 141 Broadway, New York.

MERCHANTS' THEATRE TICKET COMPANY, Wilmington, Del.; capital stock, \$100,000; to carry on a general advertising business in all its branches. Incorporators: Herbert E. Latter, William J. Maloney, Oscar J. Reichard, all of Wilmington, Del.

THE S. K. SCREEN COMPANY, Dover, Del. Capital stock, \$50,000; to manufacture, sell and deal in and with motion picture screens, etc. Incorporators: William Boyd, William F. P. Lofland, W. I. N. Lofland, all of Dover.

At Richmond, Va.: THIRTY LEAGUES UNDER THE SEA, Norfolk. Capital stock, \$50,000 to \$100,000. Objects: leasing and selling submarine films or photoplays. G. M. Williamson, president, Norfolk; Paul H. Davis, secretary and treasurer, Chicago, Ill.

At Harrisburg, Pa.: THE CLARION FEATURES COMPANY, of Pittsburgh. To manufacture motion picture machines, slides, etc.; capitalized at \$40,000. The incorporators are: G. J. Bailey, A. E. Kuntz, A. B. Wolf, W. J. Graham and Arthur Bamford, all of Pittsburgh.

At Springfield, Ill.: THE ILLINOIS FILM CORPORATION, of Springfield, has been licensed to incorporate. The capital stock is given as \$500, and the company is to manufacture motion picture films. The incorporators are: C. M. Williams, J. W. Brown and Charles P. McLaughlin.

THE R. & B. FILM COMPANY, of Chicago, has been incorporated with a capital stock of \$25,000. It is to manufacture and deal in moving picture films, etc. The incorporators are: Herman A. Bahr, Frederic A. Fischel and Ignatz Spitz.

Cosmofotofilm Co

"Where the REAL FEATURES come from"

Presents to Exhibitors Through the
Paramount Pictures Corporation

Two Exquisite Christmas Films



(Trade Mark)
London Film Co.



(Trade Mark)
London Film Co.



Scene from "The Two Columbines." Transformation Scene at the Pantomime.
This is a lovely Christmas Film.
Written and produced by George Loane Tucker and Harold Shaw.

Scene from "A Christmas Carol." The boys snowball old Scrooge.
A Christmas Picture that is a treat for Young and Old.
Produced by Harold Shaw.

"THE TWO COLUMBINES"

(TWO REELS)

Both filmed by THE LONDON FILM CO.; Copyright 1914

Featuring Edna Flugrath, Christine Raynor, Charles Rock and Hubert Willis

THE NATIONAL BOARD OF CENSORS

in passing these two pictures says:

(A Christmas Carol) "Charles Dickens' well-known Classic perfectly given; every detail of costume and English setting has had attention—Fine Acting."
(The Two Columbines) "An artistic picture—many beautiful scenes."
The MOTION PICTURE NEWS says:
"Many productions of Charles Dickens' most popular story (A Christmas Carol) have been made for the Screen, BUT THERE HAS NEVER BEEN ONE WHICH SURPASSED THIS—It is a film which the great Author himself could view without a shock were he alive today."—Clifford H. Pangburn.
"The Christmas spirit stands out in this attractive picture (The Two Columbines) in a most effective manner—the Stage scenes are well handled and depicted with accuracy and realism—a simple story which should please any audience."—C. H. Pangburn.

"A CHRISTMAS CAROL"

(ONE REEL)

MR. EXHIBITOR!

SECURE EARLY BOOKINGS ON BOTH THE ABOVE CHRISTMAS FILMS!
AND REAP A RICH HARVEST!

See or address Your Nearest Paramount Exchange or address

Cosmofotofilm Co

110 WEST FORTIETH STREET, NEW YORK

Be sure to mention "MOTION PICTURE NEWS" when writing to advertisers.

Record of Current and Coming Releases

GENERAL FILM PROGRAM

RELEASES OF NEXT WEEK

Monday, December 7, 1914.

BIOGRAPH—Just a Kid, C., 1000.....	16585
EDISON—Crystals, Their Making, Habits and Beauty, E., 500, and Buster Brown Causes a Commotion, C., 500	16591
ESSANAY—Sweedie and The Hypnotist, C., 1000.....	16593
KALEM—The Price of Silence, D., 2000.....	16586
LUBIN—Through Desperate Hazards, D., 1000.....	16594
SELIG—The Mystery of the Seven Chests, D., 2000....	16588
SELIG—Hearst-Selig News Pictorial, No. 81, N., 1000.	16592
VITAGRAPH—The Moonshine Maid and the Man, D., 1000	16590

Tuesday, December 8, 1914.

BIOGRAPH—Cousin Pons, D., 2000.....	16602
EDISON—The Rose at the Door, D., 1000.....	16595
ESSANAY—Mrs. Trenwith Comes Home, C., 1000....	16596
KALEM—In Dutch, C., 1000.....	16601
LUBIN—He Made His Mark, C., and Dobs at the Shore, C., Split Reel	16600
SELIG—Saved by a Watch, D., 1000	16597
VITAGRAPH—Sunshine and Shadows, D., 2000.....	16598

Wednesday, December 9, 1914.

EDISON—A Matter of High Explosives, C., 1000.....	16604
ESSANAY—The Fable of the Bush-League Lover Who Failed to Qualify, C., 1000.....	16607
KALEM—The Mystery of the Yellow Sunbonnet, D., 2000	16605
LUBIN—A Recent Confederate Victory, C., 2000.....	16610
SELIG—The Abyss, D., 1000	16609
VITAGRAPH—The Athletic Family, C., 1000.....	16608

Thursday, December 10, 1914.

BIOGRAPH—For Her People, D., 1000.....	11612
ESSANAY—Sophie's Sweetheart, C., 1000.....	16613
LUBIN—The Man from the Sea, D., 2000.....	16614
SELIG—Hearst-Selig No. 82, N., 1000.....	16617
VITAGRAPH—Pure Gold, D., 1000.....	16616

Friday, December 11, 1914.

BIOGRAPH—And She Never Knew, D., 1000.....	16626
EDISON—The Best Man, D., 2000.....	16618
ESSANAY—Every Inch a King, D., 2000.....	16620
KALEM—The Bold Banditti and the Rah Rah Boys, C., 1000	16622
LUBIN—On Moonshine Mountain, D., 1000.....	16625
SELIG—One Kiss, 1000.....	16623
VITAGRAPH—A Strand of Blonde Hair, C., 1000.....	16624

Saturday, December 12, 1914.

BIOGRAPH—Diogenes Weekly No. 13, C., and Saved by Their Chee-ild, C., Split Reel.....	16633
EDISON—The Stenographer, D., 1000.....	16627
ESSANAY—Broncho Billy's Dad, D., 1000.....	16628
KALEM—The Flying Freight's Captive, D., 1000.....	16632
LUBIN—Sam and the Bully, C., and The Fresh-Air Cure, C., Split Reel	16629
SELIG—The Soul Mate, C., 1000.....	16634
VITAGRAPH—How to Do It and Why, or Cutey at College, C., 2000.....	16630

RELEASES OF THE WEEK AFTER

Monday, December 14, 1914.

BIOGRAPH—The Sheriff of Willow Gulch, D., 1000...
EDISON—The Flirt, C., 1000.....
ESSANAY—Madame Double X, C., 1000.....
KALEM—The Smugglers of Lone Isle, D., 2000.....
LUBIN—A Perilous Passage, D., 1000.....
SELIG—The Lure of the Windigo, 2000.....
SELIG—Hearst-Selig News Pictorial, No. 83, N., 1000
VITAGRAPH—The Greater Love, D., 1000.....

Tuesday, December 15, 1914.

BIOGRAPH—A Scrap of Paper, D., 2000.....
EDISON—The Vanishing of Olive, D., 1000.....
ESSANAY—The Loose Change of Chance, D., 1000....
KALEM—Cupid Backs the Winners, C., 1000.....
LUBIN—It Cured Hubby, C., and Weary Willie Rags, C., Split Reel.....
SELIG—The Man from the East, D., 1025.....
VITAGRAPH—Out of the Past, D., 2000.....

Wednesday, December 16, 1914.

EDISON—On Christmas Eve, D., 1000.....
ESSANAY—Two Pop-Up Fables, C., 1000.....
KALEM—The Hate That Withers, D., 2000.....
LUBIN—The Bomb, D., 2000.....
SELIG—The Test, D., 1000.....
VITAGRAPH—The Egyptian Mummy, C., 1000.....

Thursday, December 17, 1914.

BIOGRAPH—A Natural Mistake, C., and Red Dye, C., Split Reel
ESSANAY—Snakeville's Blind Pig, C., 1000.....
MINA—The Thrilling Adventures of Verance, C., 1000.
LUBIN—When the Blind See, D., 2000.....
SELIG—Hearst-Selig News Pictorial No. 84, N., 1000..
VITAGRAPH—A Question of Clothes, C., 1000.....

Friday, December 18, 1914.

BIOGRAPH—His Prior Claim, D., 1000.....
EDISON—The Colonel of the Red Hussars, D., 2000...
ESSANAY—The Girl from Thunder Mountain, D., 2000
KALEM—Through the Keyhole, C., 1000.....
LUBIN—The Comedienne's Strategy, C., 1000.....
SELIG—The Tail of a Coat, C., 1000.....
VITAGRAPH—Who's Who in Hogg's Hollow, C., 1000

Saturday, December 19, 1914.

BIOGRAPH—The Bond Sinister, D., 1000.....
EDISON—The Birth of Our Saviour, D., 1000.....
ESSANAY—Broncho Billy's Christmas Spirit, D., 1000..
ESSANAY SPECIAL—The Battle of Love, D., 3000...
KALEM—The Black Diamond Express, D., 1000.....
LUBIN—Who's Who, C., and Shall Curfew Ring Tonight, C., Split Reel.....
SELIG—One Traveler Returns, D., 1000.....
VITAGRAPH—Mr. Santa Claus, C., 2000.....

RECORD OF CURRENT AND COMING RELEASES — Continued

UNIVERSAL PROGRAM RELEASES OF NEXT WEEK

Monday, December 7, 1914.

IMP—The Outcome, Mary Pickford Reissue, D., 1 Reel. 4363
STERLING—Billy's Charge, C., 1 Reel..... 4366
VICTOR—Terrence O'Rourke, Inn of the Winged
Gods, D., 2 Reels..... 4364

Tuesday, December 8, 1914.

CRYSTAL—Vivian's Cookies and Whose Baby, C., S. R. 4371
GOLD SEAL—The District Attorney's Brother, D., 2
Reels 4369
NESTOR—The Widow's Last, D., 1 Reel..... 4372

Wednesday, December 9, 1914.

ANIMATED WEEKLY—Weekly No. 144, N., 1 Reel. 4378
ECLAIR—For the Mastery of the World, D., 3 Reels.. 4374
JOKER—The Genii of the Vase, and Educational..... 4373

Thursday, December 10, 1914.

IMP—Three Men Who Knew, D., 2 Reels..... 4379
REX—No release this week.....
STERLING—His New Job, C., 1 Reel..... 4381

Friday, December 11, 1914.

NESTOR—Their Ups and Downs, C., 1 Reel..... 4383
POWERS—Adventures of the Nimble Dollar, D., 1 Reel 4384
VICTOR—The Little Gray Home, D., 2 Reels..... 4385

Saturday, December 12, 1914.

101 BISON—The Trail Breakers, D., 2 Reels..... 4389
FRONTIER—Her Higher Ambition, D., 1 Reel..... 4388
JOKER—Love Disguised, and Educational, Split Reel.. 4387

Sunday, December 13, 1914.

ECLAIR—The Mountain Traitor, D., 1 Reel..... 4394
L-KO—The Rural Demons, C., 1 Reel..... 4393
REX—A Night of Thrills, D., 2 Reels..... 4391

RELEASES OF THE WEEK AFTER

Monday, December 14, 1914.

IMP—The Mill Stream, D., 2000.....
STERLING—Lizzie's Fortune, C., 1000.....
VICTOR—The Wayward Son, D., 1000.....

Tuesday, December 15, 1914.

CRYSTAL—Such a Mistake, and the Glass Pistol, S. R.
GOLD SEAL—The Ghost of Smiling Jim, D., 2000....
NESTOR—The Boy Mayor, D.....

Wednesday, December 16, 1914.

ANIMATED WEEKLY—No. 145, N., 1000.....
ECLAIR—A Game of Wits, D., 2000.....
JOKER—How Father Won Out, and the Advent of the
Ingrar Neilson, Split Reel.....

Thursday, December 17, 1914.

IMP—Within the Gates of Paradise, D., 1000.....
REX—Ambition, S., 2000.....
STERLING—The Fatal Hansom, C., 1000.....

Friday, December 18, 1914.

NESTOR COMEDY—His Dog Gone Luck, and Here
and There in Japan with Homer Croy, C., 1000...
POWERS—No Release This Week.....
VICTOR—Mary Fuller, in "Heart of the Hills," D., 3000

Saturday, December 19, 1914.

101 BISON—The Christmas Spirit, D., 2000.....
FRONTIER—Title Not Decided.....
JOKER—His Doctor's Orders, C., 1000.....

Sunday, December 20, 1914.

ECLAIR—The Jewel of Allah, D., 1000.....
L-KO—The Baron's Bear Escape, C., 1000.....
REX—A Page from Life, D., 2000.....

MUTUAL PROGRAM RELEASES OF NEXT WEEK

Monday, December 7, 1914.

AMERICAN—Out of the Darkness, D., 2000..... 02696
KEYSTONE SPECIAL—His Pre-historic Past, C., 2000 02694
KEYSTONE—Other People's Business, C., 1000..... 02699
RELIANCE—Our Mutual Girl No. 47, 1000..... 02698

Tuesday, December 8, 1914.

BEAUTY—Limping Into Happiness, C., 1000..... 02704
MAJESTIC—Her Brave Hero, 1000..... 02703
THANHOUSER—The Reader of Minds, D., 2000..... 02701

Wednesday, December 9, 1914.

AMERICAN—The Girl in Question, D., 1000..... 02708
BRONCHO—The City of Darkness, D., 2000..... 02706
RELIANCE—Forest Thieves, D., 1000..... 02709

Thursday, December 10, 1914.

DOMINO—Not of the Flock, D., 2000..... 02711
KEYSTONE—The Plumber, C., 1000..... 02713
MUTUAL WEEKLY—No. 102, N., 1000..... 02714

Friday, December 11, 1914.

KAY BEE—Fortunes of War, D., 2000..... 02716
PRINCESS—In the Conservatory, D., 1000..... 02718
MAJESTIC—In Wild Man's Land, D., 1000..... 02719

Saturday, December 12, 1914.

KEYSTONE—Not yet announced, C., 1000..... 02722
RELIANCE—On the Ledge, D., 2000..... 02720
ROYAL—Percy the Milliner, C., 1000..... 02723

Sunday, December 13, 1914.

KOMIC—The House Breakers, C., 1000..... 02726
THANHOUSER—When East Meets West, 1000..... 02727
MAJESTIC—The Old Maid, D., 2000..... 02724

RELEASES OF THE WEEK AFTER

Monday, December 14, 1914.

AMERICAN—In Tune, D., 2000.....
KEYSTONE—Not Decided, C., 1000.....
RELIANCE—Our Mutual Girl, 1000.....

Tuesday, December 15, 1914.

BEAUTY—Her Younger Sister, D., 1000.....
MAJESTIC—At Dawn, D., 1000.....
THANHOUSER—The Barrier of Flames, D., 2000.....

Wednesday, December 16, 1914.

AMERICAN—The Silent Way, D., 1000.....
BRONCHO—The Panther, D., 1000.....
RELIANCE—The Joke on Yelltown, C., 1000.....

Thursday, December 17, 1914.

DOMINO—The Political Feud, D., 1000.....
KEYSTONE—Not Announced, C., 1000.....
MUTUAL WEEKLY—No. 103, N., 1000.....

Friday, December 18, 1914.

KAY BEE—The Game of Life, D., 2000.....
AMERICAN—Trapped by a Heliograph, D., 1000....
PRINCESS—When Fate Rebelled, D., 1000.....

Saturday, December 19, 1914.

KEYSTONE—Not Decided, C., 1000.....
RELIANCE—The Beat of the Year, 1000.....
ROYAL—Two Kisses, 1000.....

Sunday, December 20, 1914.

KOMIC—Bill and Ethel at the Ball, No. 13, C., 1000...
MAJESTIC—In Fear of His Past, 2000.....
THANHOUSER—Sid Nee's Finish, C., 1000.....

RELEASE DATES FOR READY REFERENCE

GENERAL FILM PROGRAM

BIOGRAPH

- 11-24. The Romance of a Poor Young Man, D.2023
- 11-26. The Way Back, D. 998
- 11-27. His Old Pal's Sacrifice, D.1000
- 11-28. Little Miss Make-Believe, D.1000
- 11-30. A Mother's Way, D.1000
- 12- 1. The Closing Web, D.1000
- 12- 3. In Quest of a Story, D.1000
- 12- 4. Making Him Cough Up, C. Bertha, the Buttonhole-Maker.
- 12- 5. The Deacon's Son, D.1000
- 12- 7. Just a Kid, C.1000
- 12- 8. Cousin Pons, D.2000
- 12-10. For Her People, D.1000
- 12-11. And She Never Knew, D.1000
- 12-12. Saved by Their Chee-ild! and Diogenes Weekly No. 13, C.1000
- 12-14. The Sheriff of Willow Gulch, D.1000
- 12-15. A Scrap of Paper, D.2000
- 12-17. A Natural Mistake, C. and Red Dye, C., split reel
- 12-18. His Prior Claim, D.1000
- 12-19. The Bond Sinister, D.1000

EDISON

- 11-30. Wood B. Wedd Goes Snipe, C.1000
- 12- 1. The Girl of the Open Road.
- 12- 2. A Double Elopement, C.1000
- 12- 4. Who Goes There? C.2000
- 12- 5. It's a Bear, C.1000
- 12- 7. Crystals, Their Making and Beauty, E. 500
Buster Brown Causes a Commotion, C. 500
- 12- 8. The Rose at the Door, D.1000
- 12- 9. A Matter of High Explosives, C.1000
- 12-11. The Best Man, D.2000
- 12-12. The Stenographer, D.1000
- 12-14. The Flirt, C.1000
- 12-15. The Vanishing of Olive, D.1000
- 12-16. On Christmas Eve, D.1000
- 12-18. The Colonel of the Red Hussars, D.1000
- 12-19. The Birth of Our Saviour, D.1000
- 12-21. The Adventures of the Wrong Santa Claus, C.1000
- 12-22. Olive Is Dismissed, D.1000
- 12-23. 'Twas the Night Before Christmas, Fant. 550
The Tip of the Dark Continent, E. 450
- 12-25. The Premature Compromise, D.2000
- 12-26. The Man Who Vanished, D.1000
- 12-28. Dr. Daly's Wedding Day, C.1000
- 12-29. The Lesson of the Flames, D.1000
- 12-30. The Courtship of the Cooks, C.1000

ESSANAY

- 12- 1. The Buffer, D.1000
- 12- 2. The Fable of "The Club Girls and the Four Times Veteran," C.1000
- 12- 3. Sophie's Fatal Wedding, C.1000
- 12- 4. The Time, the Place and the Man.2000
- 12- 5. Broncho Billy's Judgment, D.1000
- 12- 7. Sweedie and the Hypnotist, C.1000
- 12- 8. Mrs. Trenwith Comes Home, C.1000
- 12- 9. The Fable of the Bush-League Lover Who Failed to Qualify, C.1000
- 12-10. Sophie's Sweetheart, C.1000
- 12-11. Every Inch a King, two reels, D.2000
- 12-12. Broncho Billy's Dad, D.1000
- 12-14. Madam Double X, C.1000
- 12-15. Loose Change of Chance.
- 12-16. Two Pop-Up Fables, C.
- 12-17. Snakeville's Blind Pig, C.1000
- 12-18. The Girl from Thunder Mountain, D.1000
- 12-19. Broncho Billy's Christmas Spirit, D.1000
- 12-19. The Battle of Love (Special Feature), D.3000

KALEM

- 12- 7. The Price of Silence, Alice Joyce Series, D.2 reels
- 12- 8. In Dutch, C.1 reel
- 12- 9. The Mystery of the Yellow Sunbonnet, D.2 reels
- 12-11. The Bold Bandit and the Rah Rah Boys, C.1 reel
The Invisible Power, Special, D.4 reels
- 12-12. The Flying Freight's Captive, The Hazards of Helen, D.1 reel
- 12-14. The Smugglers of Lone Isle, D.2 reels
- 12-15. Cupid Backs the Winners, C.1 reel
- 12-16. The Hate That Withers, D.2 reels
The School for Scandal, D.4 reels

- 12-18. Through the Keyhole, C.1 reel
- 12-19. The Black Diamond Express, Hazards of Helen, D.1 reel
- 12-21. The Mayor's Secretary, Alice Joyce Series, D.2000
- 12-22. The Winning Whiskers, C.1000
- 12-23. The Fatal Opal, D.2000
- 12-25. The Reformation of Ham, C.1000
- 12-26. The Escape on the Limited, D.1000
- 12-28. The Black Sheep, D.2000
- 12-29. Love, Oil and Grease, C.1000
- 12-30. The Derelict, D.2000

LUBIN

- 12- 3. The Grip of the Past, D.2000
- 12- 4. A Believer in Dreams, D.1000
- 12- 5. Brown's Cook, C.400
He Wanted His Pants, C.600
- 12- 7. The Beloved Adventurer, Series No. 13, D.1000
- 12- 8. He Made His Mark, C.400
Dob's at the Shore, C.600
- 12- 9. A Recent Confederate Victory, D.2000
- 12-10. The Man From the Sea, D.2000
- 12-11. On Moonshine Mountain, D.1000
- 12-12. Sam and the Bully, C.400
The Fresh Air Cure, C.600
- 12-14. The Beloved Adventurer, No. 14, D.1000
- 12-15. It Lured Hubby, C.400
Weary Willie's Rags, C.600
- 12-16. The Bomb, D.2000
- 12-17. When the Blind See, D.2000
- 12-18. The Comedienne's Strategy, C.1000
- 12-19. Who's Who? C.400
Shall Curfew Ring To-Night? C.600
- 12-21. The Beloved Adventurer, No. 15, D.1000
- 12-22. His Suicide, C.400
Flossie's Daring Loyalty, C.600
- 12-23. The Single Act, D.2000
- 12-24. A Soldier of Peace, D.2000
- 12-25. The Lure of the Green Table, D.1000
- 12-26. Brannigan's Band, C.400
A Troublesome Cat, C.600
- 12-28. Patsy Bolivar Series, No. L, Patsy at School, C.1000
- 12-29. A Cowboy Pastime, C.1000
- 12-30. The Intriguers, D.2000
- 12-31. Fate and Fugitive, D.2000

- 12-11. One Kiss1000
- 12-12. The Soul Mate.1000
- 12-14. The Lure of the Windigo.2000
- 12-15. The Man From the East.1025
- 12-16. The Test1000
- 12-18. The Tail of a Coat.850
- 12-19. One Traveler Returns.1000
- 12-21. Not Announced.
- 12-22. Wade Brent Pays, D.1000
- 12-22. Hearst-Selig News Pictorial No. 83, N.1000
- 12-23. The Lady or the Tiger, D.1000
- 12-24. Hearst-Selig News Pictorial No. 84, N.1000
- 12-25. Wipe Yer Feet, C.950
- 12-26. Between Matinee and Night.1025
- 12-28. Not Announced.
- 12-29. Cactus Jake, Heart-Breaker, C.1000
- 12-29. Hearst-Selig News Pictorial No. 85, N.1000
- 12-30. The Old Letter, D.1000
- 12-31. Hearst-Selig News Pictorial No. 86, N.1000
1- 1. The Champion Bear Slayer.1000
1- 2. Heart's Desire1000

VITAGRAPH

- 12- 7. The Moonshine Maid and the Man, D.1000
- 12- 8. Sunshine and Shadows, D.2000
- 12- 9. The Athletic Family, C.1000
- 12-10. Pure Gold, D.1000
- 12-11. A Strand of Blond Hair, C.1000
- 12-12. How to Do It and Why, or Cutey at College, C.2000
- 12-14. The Greater Love, D.1000
- 12-15. Out of the Past, D.2000
- 12-16. The Egyptian Mummy, C.1000
- 12-17. A Question of Cloths, C.1000
- 12-18. Who Was Who in Hogg's Hollow, C.1000
- 12-19. Mr. Santa Claus, C.2000
- 12-21. Arthur Truman's Ward, D.1000
- 12-22. By the Governor's Order, D.2000
- 12-23. The Professor's Romance, C.1000
- 12-24. The Knight Before Christmas, D.1000
- 12-25. Sweeney's Christmas Bird, C.1000
- 12-26. An Affair for the Police, C.2000
- 12-28. The Product, D.1000
- 12-29. The Plot, D.2000
- 12-30. Forcing Dad's Consent, C.1000
- 12-31. Love Will Out, C.1000

RELEASE DAYS

GENERAL FILM PROGRAM

- Monday—Biograph, Edison, Essanay, Hearst-Selig News Pictorial, Kalem, Selig, Vitagraph.
- Tuesday—Biograph, Edison, Essanay, Lubin, Selig, Vitagraph.
- Wednesday—Edison, Essanay, Kalem, Lubin, Selig, Vitagraph.
- Thursday—Biograph, Essanay, Hearst-Selig News Pictorial, Lubin, Mina, Selig, Vitagraph.
- Friday—Biograph, Edison, Essanay, Kalem, Selig, Lubin, Vitagraph.
- Saturday—Biograph, Edison, Essanay, Kalem, Lubin, Vitagraph, Selig.

UNIVERSAL PROGRAM

- Monday—Victor, Imp, Powers.
- Tuesday—Gold Seal, Crystal, Nestor.
- Wednesday—Nestor, Joker, Eclair.
- Thursday—Imp, Rex, Frontier, Sterling, Animated Weekly.
- Friday—Nestor, Powers, Victor.
- Saturday—Joker, Frontier, 101 Bison.
- Sunday—Rex, Crystal, Eclair, L-KO.

MUTUAL PROGRAM

- Monday—American, Keystone, Reliance.
- Tuesday—Beauty, Majestic, Thanouser.
- Wednesday—American, Broncho, Reliance.
- Thursday—Domino, Keystone, Mutual Weekly.
- Friday—Kay-Bee, Majestic, Princess.
- Saturday—Keystone, Reliance, Royal.
- Sunday—Majestic, Komic, Thanouser.

MINA

- 12-17. The Thrilling Adventures of Count Verance, C.1000

SELIG

- 12- 5. Her Sister, D.1000
- 12- 7. The Mystery of the Seven Chests, D.2000
- 12- 8. Saved by a Watch, D.1000
- 12- 9. The Abyss1000

UNIVERSAL PROGRAM

ANIMATED WEEKLY

- 12- 2. Weekly No. 143, N.1000
- 12- 9. Weekly, No. 144, N.1 reel
- 12-16. Weekly No. 145, N.1000

101 BISON

- 12- 6. The Foundlings of Father Time, D.2000
- 12-12. The Trail Breakers, D.2 reels
- 12-19. The Christmas Spirit, D.2000

CRYSTAL

- 11-24. Sammie's Vacation, C.1000
- 12- 1. Charlie Woos Vivian, and The Barber Shop Feud; split reel.
- 12- 8. Vivian's Cookies, and Whose Baby, C., split reel.
- 12-15. Such a Mistake, and The Glass Pistol, split reel.

ECLAIR

- 11-29. The Ghost of the Mine, D.1000
- 12- 2. For the Mastery of the World, D.3000
- 12- 2. The Girl Stage Driver, D.2000
- 12- 6. The Higher Impulse, D.1000
- 12- 9. For the Mastery of the World, D.3 reels
- 12-13. The Mountain Traitor, D.1 reel
- 12-16. A Game of Wits, D.2000

FRONTIER

- 11-21. A Relic of Olden Days.
- 12- 5. The Circle of Gold, D.1000
- 12-12. Her Higher Ambition, D.1 reel

GOLD SEAL

- 11-24. The Mysterious Rose, My Lady Raffles Series, D.2000
- 12- 1. Called Back, D.4000
- 12- 8. The District Attorney's Brother, D.2 reels
- 12-15. The Ghost of Smiling Jim, D.2000



REMEMBER DECEMBER 17TH

MinA Films are being exploited by the most gigantic publicity campaign ever conducted for a single brand of pictures.

Never in the whole history of the industry has publicity been attempted on such a grand scale except by three of the large distributing organizations, and they confused the public by trying to popularize several brands at once. *MinA publicity is concentrated on MinA Films alone.*

MINA

ADE MERICA

For six months the people in every city in America—THE PEOPLE OF YOUR TOWN—have been reading in the newspapers and magazines of the actors, authors, directors, and peculiarities of manufacture which go to make MinA Films different and better than any one reel comedies they have ever known.

This remarkable advertising *to the public and to the trade* has been done *for you*. It means ready made audiences, and a continued ever growing demand because honest quality of product stands squarely back of the advertising. Book MinA Films through all licensed exchange commencing Dec. 17th and continuing every week thereafter on 1

GENERAL FILM PROGRAM

Be sure to mention "MOTION PICTURE NEWS" when writing to advertisers.

RELEASE DATES FOR READY REFERENCE — Continued

IMP

11-12.	Peg of the Wilds, D.....	2000
11-16.	The Treasure Train, D.....	2000
11-19.	The Universal Boy in "Cupid and the Fishes".....	2000
11-23.	His Gratitude, Mary Pickford Reissue, D.....	1000
11-26.	Human Hearts, D.....	3000
11-30.	The Coward, D.....	2000
12- 3.	The Young Philanthropist, D.....	1000
12- 7.	The Outcome, Mary Pickford Reissue, D.....	1 reel
12-10.	Three Men Who Knew, D.....	2 reels
12-14.	The Mill Stream, D.....	2 reels
12-17.	Within the Gates of Paradise, Christmas Drama, D.....	1000

JOKER

11-28.	He Married Her Anyhow, C., and Eccentric Comiques, E., Split Reel.	
12- 2.	The Wise Guys, C., and The Ascension of Theschynig Platt, Switzerland.....	1000
12- 5.	A Dream of a Painting, and The Porpoise Fisheries, E.; split reel.....	
12- 9.	The Genii of the Vase, and Alaska, E., split reel.....	
12-12.	Love Disguised, and Building a Locomotive, E., split reel.....	
12-16.	How Father Won Out, and The Advent of the Ingrar Neilson, D.....	2000
12-19.	His Doctor's Orders, C.....	1000

L-KO

12-13.	The Rural Demons, C.....	1 reel
12-20.	The Baron's Bear Escape, C.....	1000

NESTOR

10-27.	The Wall of Flame, D.....	
11- 3.	The Boy Major, D.....	
11- 6.	Those Were the Happy Days, C.....	2000
11-10.	The Two Thieves, D.....	
11-13.	When the Girls Were Shanghaied, C.....	
11-20.	When Their Brides Got Mixed, C.....	
	India's Defender of the British Empire, E.....	
11-24.	As We Journey Through Life, D.....	1000
12- 8.	The Widows Last, D.....	1 reel
12-11.	Their Ups and Downs, C.....	1 reel
12-15.	The Boy Mayor, D.....	1000

NESTOR COMEDY

12-18.	His Dog Gone Luck, and Here and There in Japan with Homer Croy, C.....	
--------	--	--

POWERS

11- 6.	Nan of the Hills, D.....	
11-13.	Sissy Dobins' Oil Magnet, C.....	
11-20.	A Scenario Editor's Dream, C.....	
11-27.	Sissy Dobbins, Oil Magnate, D.....	1000
12- 4.	The Heart of a Magdalene, D.....	1000
12-11.	Adventures of the Nimble Dollar, D.....	1 reel

REX

11- 8.	The Link That Binds, D.....	2000
11-12.	The Shoemaker's Eleventh, C.....	
11-15.	The Chorus Girl's Thanksgiving, D.....	2000
11-19.	His Uncle's Will, D.....	2000
11-22.	Traffic in Babes, C.....	
11-26.	Slow, but Sure, C.....	
11-29.	Lights and Shadows, D.....	2000
12- 3.	The Mystery of the Sea View Hotel, D.....	2000
12- 6.	The Lion, the Lamb and the Man, D.....	2000
12-13.	A Night of Thrills, D.....	2 reels
12-17.	Ambition, D.....	2000
12-20.	A Page from Life, D.....	2000

STERLING

- 7.	Billy's Charge, C.....	1 reel
-10.	His New Job, C.....	1 reel
-17.	The Fatal Hansom, C.....	1000

UNIVERSAL IKE

16.	The Neglected Wife.....	
3.	Mary Green's Husband, and Educational, C.....	
10.	Mary Green's Husband, and The Monkey Cabaret, C., split reel.....	

VICTOR

11-27.	Mary Fuller in The Heart of Night Wind, D.....	2000
11-30.	A Lonely Salvation, Mary Fuller, D.....	1000
12- 4.	Father Buys a Bale, C.....	1000
12- 7.	Terence O'Rourke—The Inn of the Winged Gods, D.....	2000
12-11.	The Little Gray House, D.....	2 reels
12-14.	The Wayward Son, D.....	1000
12-18.	Mary Fuller, in Heart of the Hills, D.....	3000

MUTUAL FILM PROGRAM

AMERICAN

11-25.	The Archaeologist, D.....	1000
12- 2.	The Strength of Ten, D.....	1000
12- 7.	Out of the Darkness, D.....	2000
12- 9.	The Girl in Question, D.....	1000
12-14.	In Tune, D.....	2000
12-16.	The Silent Way, D.....	1000
12-18.	Trapped by a Heliograph, D.....	1000
12-21.	The Sower Reaps, D.....	2000
12-23.	The Tin Can Shack, D.....	1000

BEAUTY

11-24.	As a Man Thinketh, D.....	1000
12- 1.	Cupid and a Dress Coat, C.....	1000
12- 8.	Limping Into Happiness, C.....	1000
12-15.	Her Younger Sister, D.....	1000
12-22.	Brass Buttons, C.....	1000

BRONCHO

12- 2.	A Romance of Old Holland.....	2000
12- 9.	The City of Darkness.....	2000
12-16.	The Panther.....	
12-28.	The Passing of Two Gun Hicks.....	

DOMINO

11-26.	The Mills of the Gods.....	2000
12- 3.	The Vigil.....	2000
12-10.	Not of the Flock.....	2000
12-17.	The Political Feud.....	2000
12-24.	The Last of the Line, D.....	2000
12-31.	Flower in the Desert, D.....	2000

KAY-BEE

11-13.	The Hateful God.....	2000
11-20.	The Master of the House.....	2000
11-27.	A Crook's Sweetheart.....	2000
12- 4.	Mother of the Shadows.....	2000
12-11.	Fortunes of War.....	
12-18.	The Game of Life, D.....	2000

KEYSTONE

10-22.	Love Siege, C.....	1000
10-24.	Stout Heart but Weak Knees, C.....	1000
10-26.	Shot in the Excitement, C.....	1000
10-26.	Dough and Dynamite, C.....	2000
10-29.	Gentlemen of Nerve, C.....	1000
10-31.	Cursed by His Beauty, C.....	1000
11- 2.	Lovers' Post Office, C.....	1000
11- 5.	Curses They Remark'd, C.....	1000
11- 7.	His Musical Career, C.....	1000
11- 9.	His Trysting Places, C.....	2000
11-12.	An Incomplete Hero, C.....	1000
11-14.	How Heroes Are Made, C.....	1000
11-16.	Fatty's Jonah Day, C.....	1000
11-19.	The Noise of Bombs, C.....	1 reel
11-21.	Fatty's Wine Party, C.....	1 reel
11-23.	His Taking Ways, C.....	1 reel
11-23.	The Sea Nymphs, C., special.....	
11-26.	His Halted Career, C.....	1 reel
11-28.	Among the Mourners, C.....	1 reel
11-30.	Leading Lizzie Astray, C.....	1 reel
12- 3.	Shotguns That Kick, C.....	1 reel
12- 5.	Getting Acquainted, C.....	1 reel
12- 7.	His Pre-Historic Past, special.....	2 reels
12- 7.	Other People's Business, C.....	1000
12-10.	The Plumber, C.....	1 reel

KOMIC

11-22.	Ethel Has a Steady (No. 11).....	
11-29.	A Corner in Hats.....	
12- 6.	Bill No. 12.....	
12-13.	The Housebreakers.....	
12-20.	Bill and Ethel at the Ball (No. 13).....	
12-27.	Love and Business.....	

MAJESTIC

11-22.	The Saving Grace.....	2000
11-24.	Another Chance.....	
11-29.	The Sisters.....	2000
12- 1.	The Old Good for Nothing.....	
12- 6.	A Question of Courage.....	
12- 8.	Her Brave Hero.....	
12-11.	In Wildman's Land.....	
12-13.	The Old Maid, D.....	2000
12-15.	At Dawn.....	
12-20.	In Fear of His Past.....	2000
12-22.	The Better Way.....	
12-27.	How Hazel Got Even.....	2000
12-29.	His Lesson.....	

MUTUAL WEEKLY

11-22.	No. 95.....	
10-27.	No. 96.....	
11- 3.	No. 97.....	
11-10.	No. 98.....	
11-17.	No. 99, N.....	
11-26.	No. 100, N.....	
12- 3.	Weekly, No. 101, N.....	
12-10.	No. 102.....	

PRINCESS

11- 6.	When Vice Shuddered.....	
11-13.	Seeds of Jealousy.....	
11-20.	The Bad Mistake.....	
11-27.	The Wild, Woolly West.....	
12- 4.	The Creator of Hunger.....	
12-11.	In the Conservatory, D.....	1000
12-18.	When Fate Rebelled, D.....	1000

RELIANCE

11-16.	Our Mutual Girl No. 44.....	
11-18.	The Hidden Message.....	
11-21.	His Responsibility.....	2000
11-23.	Our Mutual Girl No. 45.....	
11-25.	They Never Knew.....	
11-27.	The Hop Smugglers.....	
11-28.	The Kafir's Skull.....	2000
11-30.	Our Mutual Girl No. 46.....	
12- 2.	The Lucky Shot.....	
12- 5.	Who Shot Bud?.....	
12- 7.	Our Mutual Girl, No. 47.....	
12- 9.	Forest Thieves.....	
12-12.	On the Ledge.....	2000
12-14.	Our Mutual Girl, No. 48.....	
12-16.	The Joke on Yellentown.....	
12-19.	The Beat of the Year.....	
12-21.	Our Mutual Girl, No. 49.....	

ROYAL

11- 7.	Max's Money.....	
11-14.	A Fortune in Pants.....	
11-21.	Love Finds a Way.....	
11-28.	Before and After.....	
12- 5.	Sherman Was Right—It's Very Trying.....	
12-12.	Percy the Milliner, C.....	1000
12-19.	Two Kisses.....	
12-26.	Her Mother's Voice.....	

THANHOUSER

10-20.	Old Jackson's Girl.....	2000
10-25.	Mr. Cinderella.....	
10-27.	A Madonna of the Poor.....	2000
11- 1.	Shep's Race with Death.....	
11- 3.	The Turning of the Road.....	
11- 8.	Keeping a Husband.....	
11-10.	The Terror of Anger.....	
11-13.	The Chasm.....	
11-15.	The Man with the Hoe.....	
11-17.	Pawns of Fate.....	2000
11-22.	A Messenger of Gladness.....	
11-24.	Mrs. Van Ruyter's Stratagem.....	2000
11-29.	A Denver Romance.....	
12- 1.	The Center of the Web.....	2 R.
12- 4.	Naidra, the Dream Woman.....	
12- 6.	The Amateur Detective.....	
12- 8.	The Reader of Minds.....	2 R.
12-13.	When East Meets West.....	
12-15.	The Barrier of Flames.....	2 R.
12-20.	Sid Nee's Finish.....	

RELEASE DATES FOR READY REFERENCE — Continued

FEATURE RELEASES

ALCO FILM CORPORATION

ALL STAR

- 10— 5. The Nightingale, D.....5 parts
- 10—19. Shore Acres.....5 parts
- Nov. 23. Education of Mr. Pipp.....4 parts
- Dec. 28. Garden of Lies.....

LIFE PHOTO FILM CORPORATION

- Dec. 7. Springtime.....
- The Avalanche.....

POPULAR PLAYS AND PLAYERS

- 10—12. The Ragged Earl, D.....
- 10—26. Michael Strogoff, D.....5 parts
- 12—21. The Tigress.....

B. A. ROLFE PHOTO PRODUCTIONS

- Nov. Rip Van Winkle.....5 parts
- The Three of Us.....

TIFFANY MOTION PICTURE CORP.

- Heart of Maryland.....

ALLIANCE FILMS CORPORATION

COSMOS FEATURE FILM CORPORATION

- Lena Rivers, D.....5 parts
- Nov. 30. Hearts and Flowers, D.....5 parts
- The Little Girl That He Forgot...

EXCELSIOR FEATURE FILM CO.

- 11—23. When Fate Leads Trump.....
- The Under Trail.....

FAVORITE PLAYERS

- 11—16. The Man Who Could Not Lose....
- The Last Chapter.....

MASTERPIECE FILM COMPANY

- 11— 9. The Hoosier Schoolmaster.....5 parts
- The Truth Wagon.....

PROGRESSIVE MOTION PICTURE CO.

- 11— 2. McVeagh of the South Seas, D.....5 parts

SELECT PHOTO-PLAY PRODUCING CO.

- 10—26. At the Old Cross Roads, D.....5 parts

BOX OFFICE ATTRACTION CO.

BALBOA

- Nov. Little Jack.....3 reels
- Nov. 10. Message of the Mind.....3 reels
- Nov. 17. The Call of the Heart.....2 reels

NEMO

- Nov. Bitter Sweets.....3 reels

WHITE STAR

- Nov. The Mask.....2 reels
- Nov. 10. To Love and to Hold.....2 reels
- Nov. 17. Vengeance of the Flames.....3 reels

BOX OFFICE ATTRACTIONS—Special Features

- 11— 9. Life's Shop Window.....
- 11—19. The Walls of Jericho.....
- 11—29. The Thief.....

BLINKHORN PHOTOPLAYS

- Nov. The Witness Invisible, D.....3 reels
- Nov. The Aviator Traitor, D.....3 reels

COSMOFOTOFILM CORPORATION

- Nov. For Home and Country.....2 parts
- Nov. She Stoops to Conquer.....4 parts
- Nov. The Two Columbines and A Christmas Carol.....

- Nov. Called Back.....4 parts
- Nov. Beauty and the Barge.....4 parts

ECLECTIC FILM COMPANY

- Nov. Max and the Fair M.D., C.....1 part
- Nov. When Fate Was Kind, D.....3 parts
- Nov. Pathé Daily News, No. 80, N.....1 part
- Nov. More Than Queen, D.....4 parts
- Nov. Pathé Daily News, No. 81, N.....1 part
- Nov. Perils of Pauline, No. 19, D.....2 parts
- Nov. Jolts of Jealousy, C.....1 part
- Nov. Thirty Years of a Gambler's Life, D.....3 parts
- Nov. Pathé Daily News, No. 82, N.....1 part
- Nov. The Stolen Birthright, D.....3 parts
- Nov. Pathé Daily News, No. 83, N.....1 part

ITALA FILM COMPANY

- Nov. Cabiria.....
- Nov. Treasure of the Louzats.....4 parts
- Nov. Jules Porel—Serpent.....3 parts

KINETOPHOTE CORPORATION

- 10—26. Markia, or The Destruction of Carthage.....5 reels
- 11— 2. Born Again.....5 reels
- 11—16. The Coming Power.....4 reels
- 11—23. The Spirit of the Poppy.....6 reels
- 12— 7. The Span of Life.....5 reels
- 12—21. The Little Jewess.....4 reels

OZ FILM COMPANY

- Oct. Patchwork Girl of Oz.....5 parts
- Oct. His Majesty, The Scarecrow of Oz.....5 parts
- Nov. The Last Egyptian.....5 parts

CONTINENTAL FEATURES

KAY BEE

- The Battle of Gettysburg.....

KEYSTONE

- Zu Zu, the Band Leader.....

MAJESTIC

- Ruy Blas.....

MUTUAL SPECIAL

- Mexican War Pictures.....
- Seeing South America with Roosevelt.....

NEW MAJESTIC

- Sapho.....

N. Y. MOTION PICTURE

- The Wrath of the Gods.....

R & M

- The Great Leap.....
- The Gangsters of New York.....
- The Battle of the Sexes.....
- The Floor Above.....
- The Dishonored Medal.....
- The Mountain Rat.....
- Home, Sweet Home.....
- The Avenging Conscience.....

THANHOUSER

- Moths.....
- Robin Hood.....
- A Legend of Provence.....
- Frou-Frou.....
- Joseph In the Land of Egypt.....
- Cardinal Richelieu's Ward.....
- Dope.....

PARAMOUNT PICTURES

BOSWORTH

- 10— 1. Pursuit of the Phantom.....5 parts
- 10—19. Hypocrites!.....4 parts
- 11—23. The Country Mouse, C.D.....4 parts

BOSWORTH-SMALLEYS

- 12—17. False Colors, D.....5 parts
- 1—14. Aurora Leigh.....5 reels

FAMOUS PLAYERS

- 12—10. The Conspiracy.....4 reels
- 12—14. The Crucible.....5 reels
- 12—21. The Sign of the Cross.....5 reels
- 12—28. Cinderella.....5 reels
- 12—31. The Million.....4 reels
- 1—11. The Dancing Girl.....5 reels
- 1—18. The Morals of Marcus.....5 reels

JESSE LASKY COMPANY

- 12— 7. Ghostbreaker, D.....5 parts
- 1—21. Young Romance.....5 reels
- 1—25. The Goose Girl.....5 reels

LASKY-BELASCO

- 1— 4. The Girl of the Golden West.....5 reels

LASKY-LIEBLER

- 1—28. After Five.....5 reels

PICTURE PLAYHOUSE FILM COMPANY, INC.

- 12— 2. Convict 555.....
- 12—10. Partners.....

SAWYER, Inc.

- Doc.....4 reels
- The Envoy Extraordinary.....5 reels
- Thais.....4 reels
- The Fatal Night.....4 reels
- The Virgin of the Rocks.....4 reels
- Loves and Adventures of Shakespeare.....6 reels
- Saved by the Boys in Blue.....3 reels
- King of the Bowery.....4 reels
- Mona Darkfeather, Series.....2 reels
- Nell of the Circus, Cecil Spooner.....4 reels
- Spirit of the Conqueror.....5 reels
- Catch of the Sword.....3 reels
- Without Hope.....4 reels
- As a Man Sows.....5 reels
- A Factory Magdalen.....5 reels
- The Lady of Lyons.....5 reels

UNITED FILM SERVICE

WARNER'S FEATURES, INC.

EVANS

- 11—27. Pagliacci, D.....2000
- 12— 7. Everyone, D.....2900

FEATURES IDEAL

- 11— 9. The Last Chord, D.....3000
- 11—16. The Nihilist's Daughter, D.....3000
- 11—25. Zandori's Secret, D.....3000
- 12— 1. The Wolf's Prey, D.....3000

GAUNTIER

- 11—30. The Little Rebel, D.....2000

HUMANOLGY FILM PRODUCING CO.

- 12— 7. The Price He Paid, D.....5000

LUNA

- 11—12. Reuben's Busy Day, C.....1 reel
- 11—19. Sage Brush Leading Lady, C.....1 reel
- 12—26. Soul Mates, C.....1000
- 12— 2. Mountain Goat, C.....1000

MILLER BROTHERS

- 11—16. Rainbow's End, D.....3000
- 11—23. Mexican Hatred, D.....3000
- 11—30. Harvest Romance, D.....1000
- 12— 7. Romance of Coyote Hill, D.....1000

MITTENTHAL

- 11— 8. The Terror of a Great City.....3 reels

PREMIER

- 11—14. Gypsy's Warning, D.....1 reel
- 11—21. Bandit of Devil's Gap, D.....1 reel
- The Prospector's Warning.....1 reel
- 11—28. As a Man Chooses, D.....1 reel
- 12— 5. Prospector's Warning, D.....1 reel
- 12— 5. Stung by a Bee, C.....1 reel

SAVOIA

- 11— 8. The Last Chord.....3 reels

STARLIGHT

- 11—10. The Villain Still Pursued Her, C.....1 reel
- 11—17. Noisy Neighbors, C.....1 reel
- 11—23. Murder! Police! C.....1 reel
- 12— 1. Sadie as She Never Was, C.....1 reel

SUPERBA

- 11— 8. Prince Charlie, C.....1 reel
- 11—15. Taste of High Life, C.....1 reel
- 11—23. Dr. Jekyll and Mr. Hyde, D.....1 reel
- 11—29. Camille as She Never Was, C.....1 reel

WARNER'S FEATURES

- Nov. Even Unto Death, D.....
- Nov. The Serum of Reason.....4 parts

WORLD FILM CORPORATION

- 10—26. When Broadway Was a Trail.....5 parts
- 11— 2. Across the Pacific.....5 parts
- 11— 9. The Wishing Ring.....5 parts
- 11—16. One of Millions.....4 parts
- 11—23. Lola.....5 parts
- 11—30. The Dancer and the King.....5 parts
- 12— 7. The Seats of the Mighty.....
- 12—14. The Marked Woman.....
- 12—21. As Ye Sow.....
- 12—28. The Pit.....
- 1—11. Wildfire.....

CALIFORNIA MOTION PICTURE CORP.

- 11— 2. Salomy Jane.....5 parts
- 1— 4. Mrs. Wiggs of the Cabbage Patch.....
- 1—18. Mignon.....4 parts
- Lily of Poverty Flats.....
- Salvation Nell.....

Standard Polyscope Announces Its Plans

Cooper, President; H. C. Hoagland, Vice-President and General Manager of \$1,000,000 Company—List of 22 Exchanges to Be Announced Shortly

WILLIAM P. COOPER is president and H. C. Hoagland is general manager of the Standard Polyscope Corporation, a New York corporation capitalized at \$1,000,000, with temporary offices at 115 Broadway, New York City. The Standard Polyscope Corporation will put out the "Standard Program" in co-operation with the Standard Program Association, an Illinois corporation with main offices at Chicago, and with the following well known exchange men as officers: Joseph Hopp, Chicago, president; Nelson Evans, of Cleveland, and D. S. Markowitz, of Los Angeles, vice-presidents; E. T. Peter, Dallas, Texas, secretary, and Sam Werner, of St. Louis, treasurer. These gentlemen also constitute the board of directors of the Standard Program Association.

In addition to Messrs. Cooper and Hoagland, Herbert Blache, the well known producer of Fort Lee, N. J., a prominent New York lawyer, are among the present directors of the Standard Polyscope Corporation. This directorate will be increased at the next meeting on December 9 by two well known capitalists whose names will be announced later. One of these will serve as vice-president and the other as treasurer of the Standard Polyscope Corporation.

H. C. Hoagland, general manager of the Standard Polyscope Corporation, needs no introduction to the film world. He has been with Pathe Freres for six years in various and responsible capacities, serving both as advertising manager, assistant to the vice-president and as general manager of Pathe Freres. He is not only an executive of ability, but also of exceptional experience in all branches of the field.

William P. Cooper is one of the founders of the Moffett studios of Chicago and a photographic expert of wide experience who within the past few years has given himself a practical education in motion pictures. In this connection he has spent a year and a half studying modern methods of productions in the leading studios of Europe and the United States.

It is announced that the Standard program will be backed by a very large advertising appropriation. Newspapers will be used, following the line of distribution of the Standard program.

The names of the manufacturers affiliated with the Standard program will be announced later; also the nature of the program. The first date of release is set in January. The entire list of 22 exchanges will also be announced shortly.

The scheme of distribution and the appointment of the exchanges are in the capable hands of Messrs. Hopp, Evans, Markowitz, Peter and Werner, all of whom have won their laurels as efficient and successful exchange men. G. H. Virbeck will probably handle Buffalo and Boston. Detroit and Cleveland will be in the charge of Mr. Evans.

Mr. Peter will look after Texas; Atlanta and New Orleans will be under separate and central management. Baltimore and Washington will be handled from Phil-

adelphia. The Swanson-Crawford Company of St. Louis will take care of the surrounding section. A separate corporation in California, of which D. S. Markowitz is vice-president has already been formed, and will handle the coast territory as far east as Salt Lake City. Prominent exchanges will be established in Minneapolis, Omaha, Kansas City, Denver, Pittsburgh and other prominent exchange centres of the United States.

SEXTET GRAND MARCH FOR EXHIBITOR'S BALL

One of the features of the ball to be given by the Motion Picture Exhibitors' Association of Great New York in Grand Central Palace, New York City, on December 7, will be the sextet grand march. Instead of the old-time formation the front rank will be headed by six couples, well-known photoplay favorites.

These have been designated as follows: Mary Pickford and Francis X. Bushman, Mary Fuller and King Baggott, Marguerite Snow and James Cruze, Anita Stewart and Earl Williams, Clara K. Young and Marc McDermott, and Gene Gauntier and Jack Clarke.

Under the lead of these almost every other celebrity in filmdom will participate.

NEW YORK M. P. COMPANY MAY BUY WILLAT STUDIOS

It is rumored that the New York Motion Picture Company is negotiating for the purchase of the Willat laboratories and studios, at Fort Lee, N. J. This will mean the production of some of their releases in the East, a thing the company has not done for three years.

JACK DILLON A GRADUATE OF GRIFFITH COMPANIES

Jack Dillon, playing heavies for the Santa Barbara Motion Picture Company, of the Kriterion program, is perhaps one of the best known players in the field. He is one of Griffith's old associates, having been



JACK DILLON

with D. W. Griffith since the old Biograph days. Some of his best roles have been Biff Hogan in "The Gangsters"—one of Griffith's best productions—Jim Wilson in K. and E.'s "Seven Days," and Lord Chumley in "The Road to Yesterday."

ARMY OFFICER'S DAUGHTER IN FILMS

Dixie Rucker, the youngest daughter of Colonel George K. Armes, U. S. A., is one of the latest additions to the screen world.

Belasco Associate Directs "Runaway June"

Oscar Eagle, Who Was Also in Charge of the Selig Chicago Studio, Spent Last Two Months Casting the Play

"RUNAWAY JUNE," the new Reliance serial which will be released early in January will be produced by Oscar Eagle, who has just finished

been at the head of the Selig Polyscope's Chicago studio producing feature dramas, and prior to that was associated with David Belasco, the greatest producer of the age.

Oscar Eagle entered the dramatic profession as an actor in the company of McKee Rankin, was successful and followed with engagements in support of many famous players, including Frank Mayo, Frank Chanfrau, John McCulloch, Fanny Davenport, Mrs. Fiske, Viola Allen, Kyrle Bellew, Francis Starr and David Warfield, playing a repertoire of over 350 parts.

Over eighteen years ago he turned his attention to stage direction, and has since made many successful productions, notably for Liebler and Company.

Mr. Eagle has spent the last two months in rehearsing and casting "Runaway June," and at present the stock company for this gigantic production comprises over sixty members, the majority of whom come from the dramatic stage.



THE WEDDING IN "RUNAWAY JUNE"
Reliance's Forthcoming Serial

six one-reel features, each with a recognized star, for Sawyer, Inc.

Mr. Eagle for the past two years has

CHARLES PATHE

The master picture maker of the world, viewed forty thousand feet of

Balboa Feature Films

He pronounced these productions to be the finest American made pictures he had ever seen on the screen.

IMMEDIATELY

he closed a contract for the entire amount consisting of 2, 3 and 4 reel dramas and one reel comedies. These pictures will be released soon and distributed through THE ECLECTIC FILM COMPANY. Write, telegraph or telephone their nearest exchange for

BALBOA-PATHE

“The Pictures Beautiful”

Merit counts and we will continue to give the Exhibitor and public pictures that are worth while

BALBOA AMUSEMENT PRODUCING CO.

H. M. HORKHEIMER
President and General Manager

E. D. HORKHEIMER
Secretary and Treasurer

Studios and Executive Offices
LONG BEACH, CALIFORNIA

ALLIANCE

The Last Egyptian

A Sensational Egyptian Story



Perfect
Photo-
graphy
In Five
Parts

Exquisite
Light
Effects
Released
Dec. 7th

WITH

Farrell McDonald AND Miss Vivian Reed

IN THE LEADING ROLES

Produced by the Oz Film Company

Released on

ALLIANCE PROGRAMME

Be sure to mention "MOTION PICTURE NEWS" when writing to advertisers.

PROGRAMME

CURRENT RELEASES

THE KEY TO YESTERDAY

From the Novel by
Charles Nevil Buck

with

CARLYLE BLACKWELL

THE PATH FORBIDDEN

From the Novel by
John Hymer

with

OCTAVIA HANDWORTH

AT THE OLD CROSS ROADS

From Arthur C. Aistons'
famous play

with

ESTHA WILLIAMS

THE HOOSIER SCHOOLMASTER

From the great American
Story by Edw. Eggleston

with

MAX FIGMAN

THE MAN WHO COULD NOT LOSE

By Richard
Harding Davis

with

CARLYLE BLACKWELL

WHEN FATE LEADS TRUMP

From Novel by
Alice M. Roberts

with

OCTAVIA HANDWORTH

FORTHCOMING RELEASES

HEARTS AND FLOWERS

From the celebrated
play of the same name

with

MRS. THOMAS WHIFFEN

THE LAST EGYPTIAN

From the book by
L. Frank Baum

with

FARRELL McDONALD and VIVIAN REED

THE LAST CHAPTER

By Richard
Harding Davis

with

CARLYLE BLACKWELL

THE TRUTH WAGON

From the play by
Hayden Talbot

with

MAX FIGMAN

EXCHANGES

ALLIANCE FILM SERVICE, 115 Fourth Ave., Pittsburgh, Pa. A. A. Welland, Mgr. *Ohio, Western Pennsylvania, Kentucky and West Virginia.* (Kentucky exhibitors will be served from Cincinnati office after Dec. 1.)

ALL THEATRES, FILM AND ACC. CO., INC. Owners of Alliance Film Exchanges, New York State. Buffalo Office, 18 Chapin Block; S. S. Webster, Mgr.; I. Cobe, Gen. Rep. New York City Office, 126 West 46th St.

ALLIANCE FILM SERVICE, controlled by Eastern Feature Film Co., Inc., 57 Church St., Boston, Mass. *New England*

ALLIANCE FEATURE FILM SERVICE, controlled by Mecca Feature Film Co., 130 West 46th St. *Northern New Jersey.*

ELECTRIC THEATRE SUPPLY CO., Vine and 13th St., Phila., Pa. *Southern New Jersey, Eastern Pennsylvania, Maryland, Delaware, District of Columbia.*

APEX FEATURE SERVICE, 311 Andrews Bldg., Dallas, Texas. M. LeVison, Mgr. *Texas, Arkansas and Oklahoma.*

APEX FEATURE SERVICE, 417 Rhodes Building, Atlanta, Ga. O. P. Hall, Mgr. *Virginia, North Carolina, South Carolina, Georgia, Florida, Alabama, Mississippi, Louisiana.*

CASINO FEATURE FILM CO., Dime Savings Bank Bldg., Detroit, Mich. *Michigan.*

CELEBRATED PLAYERS FILM CO., 64 West Randolph St., Chicago, Ill. *Illinois and Indiana.*

NAT A. MAGNER CO., Pacific Bldg., San Francisco, Calif.; 218 Superba Theatre Bldg., Los Angeles, Calif. *California, Nevada and Arizona.*

DES MOINES FILM SUPPLY CO., 218 Utica Bldg., Des Moines, Ia. *Iowa.*

MONARCH FEATURE FILM CO., 12th and Wyandotte Sts., Kansas City, Mo. *Missouri, Kansas and Nebraska.*

ZENITH FEATURE FILM CO., Lyceum Bldg., Duluth, Minn. *Minnesota, North and South Dakota and Wisconsin.* Milwaukee Office, 407 Manhattan Bldg.

ALLIANCE FILM SERVICE, controlled by Noted Players Feature Film Co., 613 New Birks Bldg., Montreal. Jas. D. Goldie, Gen. Mgr., *Canada.*

ALLIANCE FILMS CORPORATION 126 W. 46th STREET
NEW YORK CITY

Be sure to mention "MOTION PICTURE NEWS" when writing to advertisers.

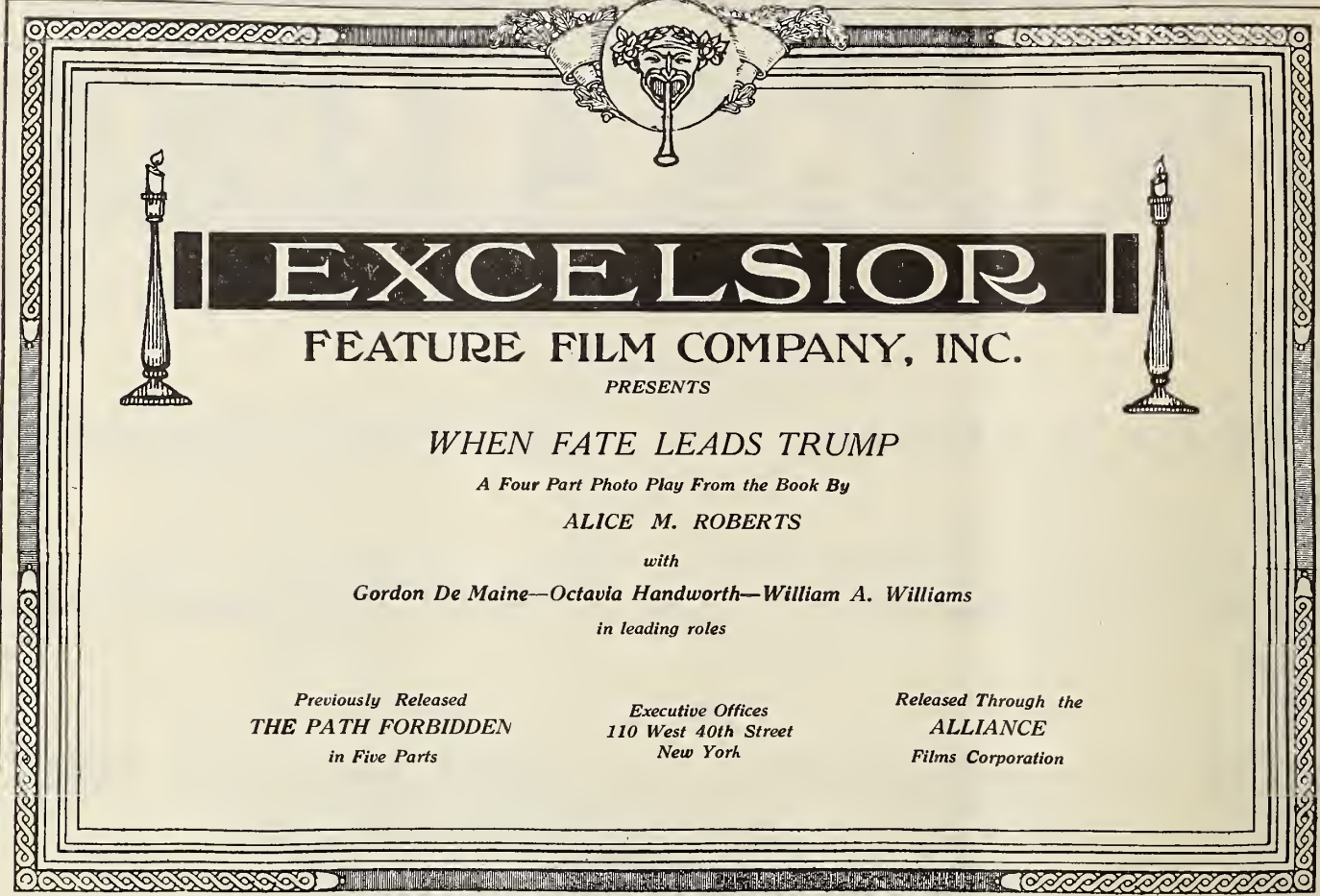

EXCELSIOR
FEATURE FILM COMPANY, INC.
PRESENTS

WHEN FATE LEADS TRUMP
A Four Part Photo Play From the Book By
ALICE M. ROBERTS
with
Gordon De Maine—Octavia Handworth—William A. Williams
in leading roles

Previously Released
THE PATH FORBIDDEN
in Five Parts

Executive Offices
110 West 40th Street
New York

Released Through the
ALLIANCE
Films Corporation

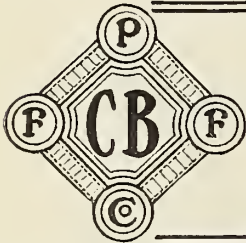

FAVORITE PLAYERS FILM COMPANY

PRESENT

"THE MAN WHO COULD NOT LOSE"

A Five Part Photo Play From the Book By
RICHARD HARDING DAVIS

Previously Released
THE KEY TO YESTERDAY

Executive Offices:
110 W. 40th St., N. Y. C.

Released Through the
ALLIANCE FILM CORP.

WE

**OWN AND CONTROL
50 THEATRES—
USE FEATURES—
BUY SUPPLIES—FOR
OUR OWN HOUSES
WHAT HAVE YOU TO
OFFER?—COME AND
SEE US**

50

LEADING PHOTOPLAY EXHIBITORS, Inc.

Room 403, 110 West 40th Street, New York City

Phone, Bryant 4201

"HARD TIMES" FLY OUT OF THE WINDOW

When MOTION PICTURE NEWS Comes In By The Mail

Ask any live wire Exhibitor if it's true.

Order your CHRISTMAS ISSUE Now

A KINETOPHOTE FEATURE WINS QUICK RETURNS

THE ENTIRE COUNTRY IS BOOKING
THESE KINETOPHOTE RELEASES

“THE SPIRIT OF THE POPPY”

with Edward Mackay

“THE SPAN OF LIFE”

with Lionel Barrymore

“THE COMING POWER”

with Lionel Adams

“MARKIA” or “THE DESTRUCTION OF CARTHAGE”

the \$200,000 Ambrosio Production

WRITE TO THE NEAREST
EXCHANGE NOW!

AMERICAN FEATURE FILM CO., 162 Tremont St., Boston, Mass.—Maine, New Hampshire, Vermont, Massachusetts, Rhode Island and Connecticut—All New England.

EASTERN BOOKING OFFICES, 1237 Vine St., Philadelphia—Eastern Pennsylvania, Southern New Jersey, Virginia, Delaware and District of Columbia.

EASTERN BOOKING OFFICES (Pittsburgh Branch, 432 Wabash Bldg.)—Western Pennsylvania and West Virginia.

EASTERN BOOKING OFFICES (Cleveland Branch, 218 Columbia Bldg.)—State of Ohio.

K. C. BOOKING CO., INC. (Chicago Branch, Mallery Bldg., S. E. corner Madison and Wabash)—Illinois.

MIDWEST FEATURE FILM CO., Loeb Arcade Bldg., Minneapolis, Minn.—Minnesota, Iowa, North and South Dakota and Wisconsin.

CALIFORNIA FILM SERVICE CORP., 1149 Mission St., San Francisco, Cal. (with branches in Salt Lake City, Utah, Denver, Seattle, Portland, Ore., and Los Angeles)—California, Oregon, Washington, New Mexico, Montana, Idaho, Wyoming, Colorado, Nevada, Arizona and Utah.

DALLAS FILM CO., Dallas, Texas—Texas, Louisiana, Oklahoma and Arkansas.

ALL BOOKING THE EXCLUSIVE PROGRAM OF



Feature

Productions

Telephone: *6072 Bryant

126-132 West 46th Street, NEW YORK

THE ALBUQUERQUE FILM MFG. COMPANY, Inc.

Featuring that clever
Comedienne

Miss Dot Farley

Two Comedies Weekly

RELEASING THROUGH
The United Motion Picture Producers, Inc.
WHO DISTRIBUTE THROUGH
Warner's Features, Inc.

By request from many exchanges
we take pleasure in
reviving the

FRONTIER TWIN STORIES

Written and made famous by Miss Dot
Farley. Under direction of
Gilbert P. Hamilton

Farce Comedy Production

BY

ARCHER McMACKIN

Nuf Sed

WESTERN STUDIO

406 Court St. Los Angeles, Calif.

GILBERT P. HAMILTON, Pres. and Gen. Mgr.

MRS. WILCOX VISITS WARNER STUDIOS.

AN inspection of the general offices of the United Film Service (Warner's Features, Inc.), in the Leavitt Building, was made several days ago by Ella Wheeler Wilcox, the poetess, who recently became interested in motion picture writing. Mrs. Wilcox was much impressed with the magnitude of the United Enterprise, and the widespread popularity of screen drama.

"I have never realized until this day what a wonderful force in modern life has become this comparatively recent innovation, the moving picture," she said. "I believe the day is near when the screen drama will enlist the services of our most adept playwrights and novelists to furnish the themes and our foremost actors and actresses of the legitimate stage to interpret them. In fact, I think that photoplays will be primarily and exclusively responsible for a new school of acting in this country—a school of acting which will be far more subtle and artistic than that now to be seen on our stage.

"As you may be aware," continued Mrs. Wilcox, turning to P. A. Powers, president of the United Film Service, who was conducting Mrs. Wilcox through the various offices of the film organization, "The art of pantomime, which is so interesting a department of dramatic art in Europe, is virtually unknown in this country. Pantomime, of necessity, is the great requirement of the photoplay."

Mrs. Wilcox has completed a version in photoplay form of "The Price He Paid," one of her most famous poems, which the Humanology Film Producing Company, of which Jack Rose is president, has produced for distribution by the United Film Service (Warner's Features, Inc.) in December.

ANIMATED WEEKLY COVERS FOOTBALL GAME

FINE pictures were obtained by the "Animated Weekly" camera man of the Yale-Harvard game at New Haven on Saturday, November 21.

The same evening prints of the "Weekly" were shipped to the exchanges, and were received and run by them on Monday.

Give Your Lobby A Christmas Gift!

Life size photographs of your patrons' favorites—or smaller sizes—from original negatives add wonderfully to your display

- stops the passers,
- brings them into the ticket booth,
- increases box office receipts.

Numerous poses of famous photoplayers—straight and character. Prints in all standard sizes and finishes.

Write

PHOTOPLAYERS STUDIOS
342 South Broadway
LOS ANGELES

RELEASE NOV. 23rd

DIGBY BELL
in
THE EDUCATION OF MR. PIPP
(5 Parts)

—DECEMBER 28th—

JANE COWL
in
THE GARDEN OF LIES

All Star Feature Corp.
220 West 42d Street New York

LE COURRIER
Cinematographique
28 Boulevard St. Denis, Paris
Directeur: Charles LE FRAPER

Journal hebdomadaire français, le plus important de l'industrie cinématographique.

Envoie numéro spécimen, sur demande.

VITAGRAPH

"THE MOONSHINE MAID AND THE MAN", Drama Monday, Dec. 7th
Dave is after the moonshiners and \$1,000 reward to marry Nance. He is shot by his prey and learns they are Nance and her father. HELEN GARDNER and NED FINLEY in the leads.

"SUNSHINE AND SHADOWS", Drama in Two Parts Tuesday, Dec. 8th
Far from their enemies, husband and wife forget the past. Their happiness is again disturbed by their persecutors, but they triumph in their love and the overthrow of their traducers. An all-star cast.

"THE ATHLETIC FAMILY", Comedy Wednesday, Dec. 9th
Always in training. They do some startling things; full of laughs and surprises. The twins are a great team and add to the fun. WILLIAM SHEA and KATE PRICE are part of the family.

"PURE GOLD", Drama Thursday, Dec. 10th
The man's disrespect for women changes to love and esteem when he discovers Anne's real worth and character. ANNE SCHAEFER and WILLIAM DUNCAN are the principals.

"A STRAND OF BLOND HAIR", Comedy Friday, Dec. 11th
It gets into Bunny's pocket. FLORA FINCH discovers it there and traces it to another woman. You can guess the rest.

"HOW TO DO IT AND WHY" or "CUTEY AT COLLEGE", Comedy in Two Parts Saturday, Dec. 12th
Cutey finds the hook-agent a ready help in time of need. He hypnotizes and interests. He wins the landlady for himself and her daughter for Cutey. He puts everybody in good humor. An all-star cast.

SIX A WEEK

"THE GREATER LOVE", Drama Monday, Dec. 14
"OUT OF THE PAST", Drama Tuesday, Dec. 15
"THE EGYPTIAN MUMMY", Comedy Wednesday, Dec. 16
"A QUESTION OF CLOTHES", Comedy Thursday, Dec. 17
"WHO WAS WHO IN HOGG'S HOLLOW", Comedy Friday, Dec. 18
"MR. SANTA CLAUS", Comedy-Drama in Two Parts Saturday, Dec. 19

VITAGRAPH ONE, THREE AND SIX SHEET POSTERS

The Vitagraph Company of America
East 15th St. and Locust Ave. Brooklyn, N. Y.

BROADWAY STAR FEATURES

RELEASED

- A Million Bid 5 Parts
- Goodness Gracious 3 Parts
- Mr. Barnes of N. Y. 6 Parts
- Love, Luck and Gasolene 3 Parts
- Captain Alvarez 6 Parts
- Shadows of the Past 3 Parts
- Mr. Bingles' Melodrama 3 Parts
- My Official Wife 5 Parts
- Uncle Bill 3 Parts
- The Painted World 3 Parts
- A Florida Enchantment 5 Parts
- 413 3 Parts
- The Win(k) some Widow 4 Parts
- The Tangle 4 Parts
- The Locked Door 3 Parts
- Sylvia Gray 4 Parts
- The Little Angel of Canyon Creek 5 Parts

COMING

- 3-Part Drama of Life
TWO WOMEN
- 3-Part Western Drama
THE SAGEBRUSH GAL
A Powerful Screen Story
From Frederick Chapin's Novel
- 4-Part Comedy
THE MAN BEHIND THE DOOR
From A. C. Gunter's Story
- 4-Part Comedy
C. O. D.
A Wonderful Screen Version of Frederick Chapin's Laughing Story

As presented at the VITAGRAPH THEATRE, New York City
For terms and particulars apply
GENERAL FILM COMPANY'S SPECIAL SERVICE
By Arrangement With BROADWAY STAR FEATURE CO.,(Inc.)

QUALITY FIRST



STANDARD POLYSCOPE CORPORATION
 OF NEW YORK
 (Authorized Capital \$1,000,000)

PRESENTS
STANDARD PROGRAM

A new program of superlative quality of single and multiple reel subjects, including an excellent comedy every day!

REGULAR WEEKLY RELEASES BEGIN
JANUARY 18th, 1915

THROUGH THE **STANDARD PROGRAM ASSOCIATION**
 (Incorporated under the Laws of Illinois)

JOSEPH HOPP, PRES.
 164 W. Washington St.
 Chicago, Ill.

OFFICERS
SAMUEL WERNER, TREAS.
 14 North Ninth St.
 Chicago, Ill.

E. T. PETERS, SECY.
 Dallas, Texas

OLD TIME EXCHANGEMEN — EXPERT MANUFACTURERS
AND A BRAND NEW BASIC PRINCIPLE—

NOTHING TOO GOOD FOR THE EXHIBITOR!

STANDARD POLYSCOPE CORPORATION

115 BROADWAY

NEW YORK CITY

WILLIAM P. COOPER
 President

H. C. HOAGLAND
 General Manager



STATE RIGHT BUYERS

Our Next Release

“**The** **Little** **Girl** **That** **He** **Forgot**”

FEATURING **Beulah Hoynter**

IN
Her Greatest
Dramatic Triumph

A Five Part Photoplay
With:
Well Balanced Cast
Pretty Scenic Effects
Superb Photography

WIRE OR WRITE IMMEDIATELY!

Cosmos Feature Film Corporation

126-130 WEST 46th STREET, NEW YORK

TOM TERRISS

The Famous English Player has joined the

KINETOPHOTE

Mr. Terriss will produce and star in the Famous Terriss Plays under the K. C. Emblem

He will be assisted by

ANNA LUTHER

in the first of the series

“A MAN’S SHADOW”

Ask for an Early Booking through the

Feature

**K. C.
BOOKING
CO.**

Productions

Incorporated

TELEPHONE * 6072 BRYANT

NEW YORK CITY

126 WEST 46TH STREET

“Comedies
OF
Realization”



“Comedies
THAT
Will Live”

FIRST RELEASES

OF THE

Flamingo Film Company

FOUR GREAT COMEDIES

resulting from The Morning Telegraph-Chartered Theatres Corporation

NATIONAL PRIZE SCENARIO CONTEST

RELEASED DECEMBER 20

Elaine Sterne's Great Comedy-Drama in Four Reels

“WITHOUT HOPE”

Produced by Fred Mace and an All Star Company
Great in Story—Rich in Humor—A Masterpiece of Photography

Released January 10

“Puritan Conscience”

A 3 Reel Farce Comedy by
Caroline Wells

Released January 31

“The Sibyl of the Film”

A 2 Reel Comedy Drama by
Samuel C. Appleby

FEBRUARY RELEASE

“A JAY IN PEACOCK ALLEY”

A Satirical Comedy in 2 Reels by Roy L. McCardell

Book this great series of Comedies Now

Sole Distributor of Flamingo Comedies

SAWYER, Inc.

1600 Broadway, New York



GNATS AND CAMELS

(No. 60. Straight-from-the-Shoulder Talks by Carl Laemmle, President.)

I PUBLISHED an editorial a few weeks ago in which I made the remark that we gave Universal exhibitors such serials as "LUCILLE LOVE" and "THE TREY O' HEARTS" at such a low price that we lost money on the deal. I added that we intended to get more for "THE MASTER KEY."

Since then I have been receiving occasional letters from exhibitors, saying that they had to pay extra for the two serials mentioned. They feared their exchanges had put something over on them, as they expressed it.

It is true that in some Universal exchanges an extra charge was made for the two serials in question. But in no case was the extra charge ANYTHING LIKE THE EXTRA MONEY THAT THE EXHIBITORS MADE ON THE PICTURES. And the only exchanges adopting this policy were those charging so little for their regular service that it would have been folly to add the serials to a measure of value that was already heaping.

One of the exhibitors who made a complaint because he feared he had been overcharged was a man who paid \$10 a day for "LUCILLE LOVE" and \$10 a day for "THE TREY O' HEARTS". I happened to know that this very same exhibitor has on many occasions paid from \$25 to \$40 a day for some of the so-called "features" made by amateur concerns in an amateur way. The pictures that he paid such prices for were not in the same class with our serials, NOR DID THEY DRAW ANYTHING LIKE THE CROWDS. Nor were they advertised in such a tremendous way as we have advertised the Universal serials. Nothing like the advertising campaign that we have waged for Universal serials has ever been undertaken in the moving picture business. It has been one of the greatest things ever done for the exhibitor, who, by the way, gets the

first direct results of the big amounts of money we spend in advertising.

The exhibitor mentioned in the foregoing paragraph strained at the goat of paying \$10 extra for a big drawing card, but he swallowed the camel of paying \$25 to \$40 for something that DIDN'T GET HIM ANYTHING.

I said that we HANDED THE EXHIBITORS OUR SERIALS ON A PLATTER, and I still repeat the remark, even if some exhibitor did pay the sum of \$10 or \$15 a day for a Universal serial that brought him in several times that amount; or if his weekly service price was increased during the time that he ran the serial.

Exhibitors should not forget that each one of our serials HAS GUARANTEED HIM STEADY PATRONAGE FOR AT LEAST FIFTEEN WEEKS. If we had skimmed on the quality of our serials, or if we had let up in our advertising expenditures his patronage might not have been so steady. But we protected him to the last minute.

When I look about at the many fakirs, in New York and elsewhere, who are marketing pictures that the Universal REFUSED BECAUSE THEY WERE SO MISERABLE; when I see such men getting great big fancy prices for their junk; when I see charlatans WHO HAVE NEVER INVESTED A CENT IN THE BUSINESS doing a big trade JUST BECAUSE THEY ASK ATROCIOUS PRICES, I sometimes wonder if the Universal's policy of giving the people more than their money's worth is good sense or rank folly.

Then the consoling thought comes to me that the house that gives the big honest value is going to win in the long run; and that the fakir will in time destroy himself, even though there are still some exhibitors who strain at gnats and swallow camels.

(From The Universal Weekly. Exhibitors, regardless of what program they are using, may have the Universal Weekly EVERY WEEK by writing the Editor, at 1600 Broadway, New York.)

LUBIN

LUBIN MASTERPIECES

Now Ready and About To Be Released
(Through the General Film Special Service)

EDWIN ARDEN

Drama IN "EAGLE'S NEST" *Direction—*
By Edwin Arden *Romaine Fielding*

RAYMOND HITCHCOCK

(The Funniest Man on the Stage)
IN "THE RINGTAILED RHINOCEROS"
Comedy Drama *Direction—*
By Lawrence S. McCloskey *George W. Terwilliger*

"THE WHITE MASK"

FEATURING LILIE LESLIE
Drama *By Clay M. Greene* *Direction—Joseph W. Smiley*

ROSE COGHLAN

And ETHEL CLAYTON in
"THE SPORTING DUCHESS"
Comedy Drama *By Cecil Raleigh* *Direction—Barry O'Neil*

"THE COLLEGE WIDOW"

Featuring Ethel Clayton and George Soule Spencer
Comedy *Direction—*
By George Ade *Barry O'Neil*

"THE VALLEY OF LOST HOPE"

Drama *By Shannon Fife* *Direction—Romaine Fielding*

NOW SHOWING WITH SUCCESS (BY ARRANGEMENT)
(WITH FRED MACE)

EVELYN NESBIT THAW and her son RUSSELL
WILLIAM THAW in "THREADS OF DESTINY"
Drama *By William H. Clifford* *Direction Joseph W. Smiley*

SIX REGULAR RELEASES EACH WEEK

"THE BELOVED ADVENTURER," No. 13, {	<i>Drama</i>	Monday,	December 7th
"Through Desperate Hazards"			
"HE MADE HIS MARK" {	Split Reel Comedies.....	Tuesday,	December 8th
"DOBS AT THE SHORE" {			
"A RECENT CONFEDERATE VICTORY"—Two Reel Drama..		Wednesday,	December 9th
"THE MAN FROM THE SEA"—Two Reel Drama.....		Thursday,	December 10th
"ON MOONSHINE MOUNTAIN"—Drama.....		Friday,	December 11th
"SAM AND THE BULLY" {	Split Reel Comedies.....	Saturday,	December 12th
"THE FRESH AIR CURE" {			

SPECIAL—ONE, THREE AND SIX SHEETS.

Lubin Manufacturing Company, Philadelphia, Pa.

Chicago Office:
154 West Lake Street



WARNING

"All releases of Keystone films are now being copyrighted. All infringers and 'dupers' will be apprehended and punished to the extent of the law."

THE KEYSTONE FILM COMPANY

A. KESSEL, JR., President

Longacre Building, Broadway and 42nd Street

NEW YORK CITY

BETTER LIGHT

LESS CURRENT

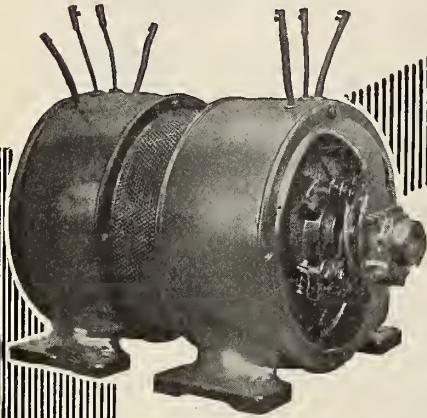

The DC Compensarc lowers the voltage of a direct current supply to that required at the lamp without needless waste.

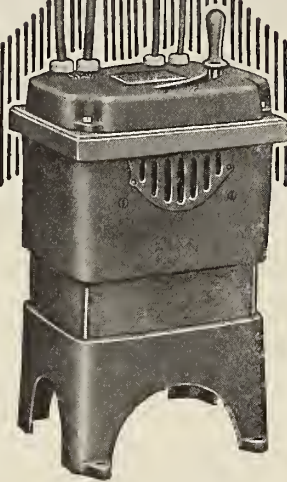

The AC Compensarc cuts $\frac{2}{3}$ from your lighting bill if you use alternating current.

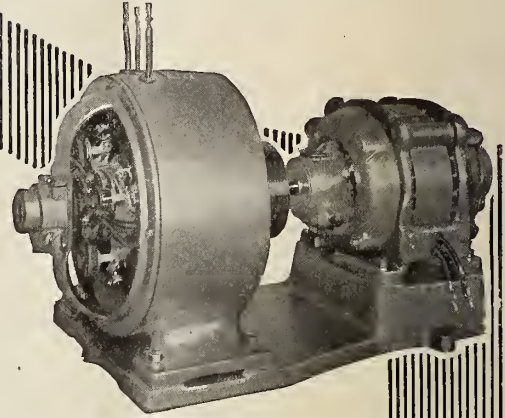

The AC to DC Compensarc will transform alternating into direct current and reduce the voltage at the same time without need less waste.

No matter what current you have---Alternating or Direct---or what voltage or frequency, one of the

FORT WAYNE COMPENSARCS

will enable you to secure a light that will give those clear, bright pictures that everybody now demands.

What's the use of paying extra money for special screens, projecting machines, and first run films and then spoil the whole result with poor light? With the Fort Wayne Compensarcs you can get any kind of light you want regardless of the kind or quality of your current supply.

The Compensarcs will give you

STEADY LIGHT. No flickering, no sputtering, even when changing intensities or from one machine to another.

WHITE LIGHT. No yellow streaks, no ghosts.

BRIGHT LIGHT. Three times the light with two-thirds the current.

They are safe, efficient, easy to operate, fool proof and reliable.

FORT WAYNE ELECTRIC WORKS

OF GENERAL ELECTRIC COMPANY

1704 BROADWAY

FORT WAYNE, INDIANA

Compensarcs are so commonly found in motion picture theatres that many people now call all current saving and transforming devices by that name.

But Remember

*If it isn't a FORT WAYNE
it isn't a "COMPENSARC"*

*Send TODAY for this
FREE descriptive booklet*

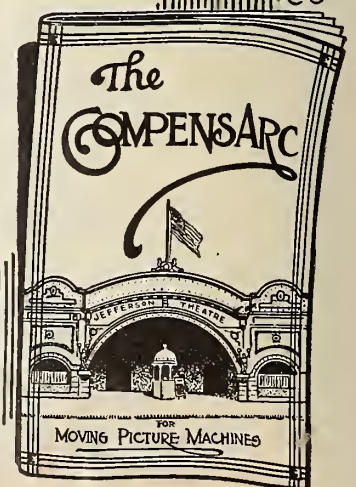

DECEMBER 12, 1914

Accessory News

THE CONSTRUCTION, EQUIPMENT AND OPERATION OF THE MODERN PICTURE THEATRE
VOLUME X

NUMBER 23

STUDIO FOR RENT

Because our entire producing force has been transferred for the winter to Horsley Park in Los Angeles, we are offering for rent at moderate terms one of the most modern and thoroughly equipped studios in America. Only 20 minutes from 42d Street, New York

CENTAUR FILM CO.
BAYONNE NEW JERSEY



MOTIOGRAPH



When buying a MOTIOGRAPH Projector, you get more machine value per dollar than when purchasing any other machine.

— READ THE PROOFS —

Very large well-ventilated lamp-house.

Condenser Mounts well-ventilated.

Slide Carrier Swing. Allows 20 per cent. more illumination. No other machine has it.

Motiograph Arc Lamp with all adjustments necessary to produce a perfect arc.

Light Cone Tube. Keeps operating room dark, saves operator's eyes. Can be thrown back as shown.

Very large lamphouse door which all operators like.

Mechanism dust proof and made of high grade gray iron. All parts within are of the finest quality steel accurately machined. Wearing parts hardened and ground to insure accuracy. Inside double cone interrupter shutters which permit the utilization of more light and prevents shutters from getting out of time, and insures your projection against what is known as "travelghost"

Speed Control. Will control speed from 8 to 20 minutes per thousand feet of film.

Adjustable Grid Rheostat 20 to 55 amperes.

Magazines. Made of heavy material and has spring doors. Will hold two thousand feet of film.

Lamphouse brace to eliminate vibration.

One-eighth H. P. Motor, fully enclosed. Can be attached to all past models.

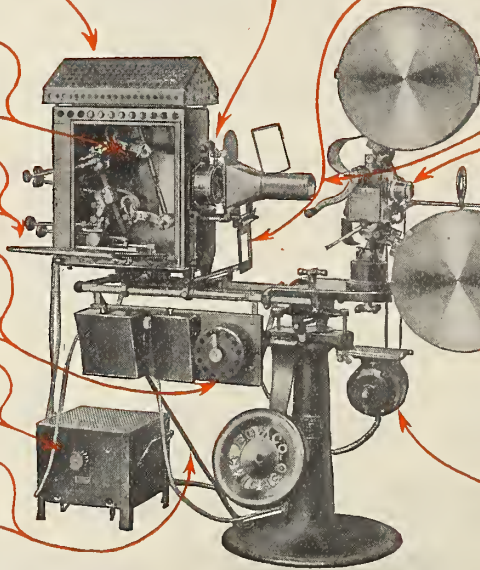

Intermittent movement the most vital part of all projectors. Can be installed in Motiograph in 30 seconds. This extra movement will insure your show at all times.

Star and Cam ground and hardened to insure accuracy.

Sprockets of solid steel carefully finished in the Motiograph way.

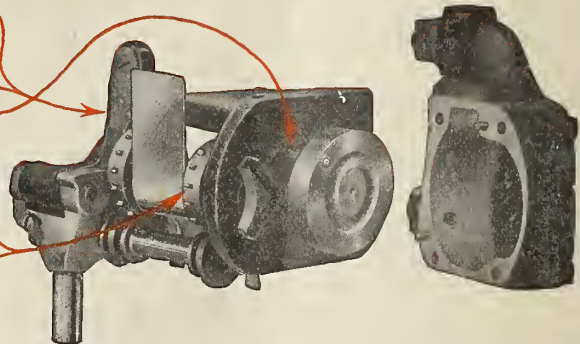

I have had a Motiograph for two years, to date, have been running steady since day of purchase without one cent of repairs on it. It is actually the best piece of machinery I have ever seen, gives a perfect steady, clear projection.

Star Theatre, Zelenpole, Pa.

Permit us to inform you the Motiograph gives us entire satisfaction and very much to our surprise was able to project a picture on a screen in broad daylight so that it could be seen by people passing by on the street.

Chicago Herald Movies.

I do not see how a machine can be made any better. My Motiographs have been running constantly for two years with no trouble.

Rex Theatre, St. Petersburg, Fla.

THE ENTERPRISE OPTICAL MFG. CO.

568 West Randolph Street, . . . CHICAGO, ILL.

EASTERN OFFICE: 19 West Twenty-third Street, NEW YORK

WESTERN OFFICE: 833 Market Street, SAN FRANCISCO



MOTIOGRAPH



Construction,
Equipment
and Operation

Accessory News

Everything for
the Modern
Picture Theatre

TEL. 7650 BRYANT

TWO HUNDRED AND TWENTY WEST FORTY-SECOND STREET

NEW YORK CITY

Volume X

DECEMBER 12, 1914

Number 23

Making a Church Into a Successful Theatre

CHANGING a church building into a theatre building, and entirely losing the "churchy" feeling and instilling a distinct theatrical effect into the same building, is not often done, but from the illustrations shown of the interior and exterior of the Liberty theatre, one can see how completely this change has been brought about, without expending an undue amount of money.

The Liberty is owned and operated by John H. Kunsky, of Detroit, and is one of the most successful of theatres devoted exclusively to moving pictures in that city. Although this theatre is located on a side street, off from the main travel, it is decidedly popular, and the people seem to like its clean defined lines and the cozy atmosphere that prevails throughout the entire house.

In order to entirely lose the church effect on the exterior, the tower, or steeple, was completely removed, the old win-

A rather elaborate ventilating system has also been installed which provides plenty of fresh air for the patrons and also exhausts the foul air, making a complete change of air every few minutes.

There is a large pipe organ installed at the rear of the theatre, over the operating room, with a keyboard controlling the same in the orchestra pit. This arrangement seemed rather impractical, when it was first suggested, but as there was absolutely no other place for the organ, it was decided to install it in this location. The effects are everything that can be desired and very satisfactory; in fact, the organ and orchestra play together just as well as if, the organ were in the pit with the musicians.

The interior effects lean a little to the garden order; that is, lattice work, trellis work and artificial flowers are the principal form of decorations. There is something cool and re-

FROM CHURCH TO PLAYHOUSE—THE EVOLUTION OF THE LIBERTY THEATRE, DETROIT

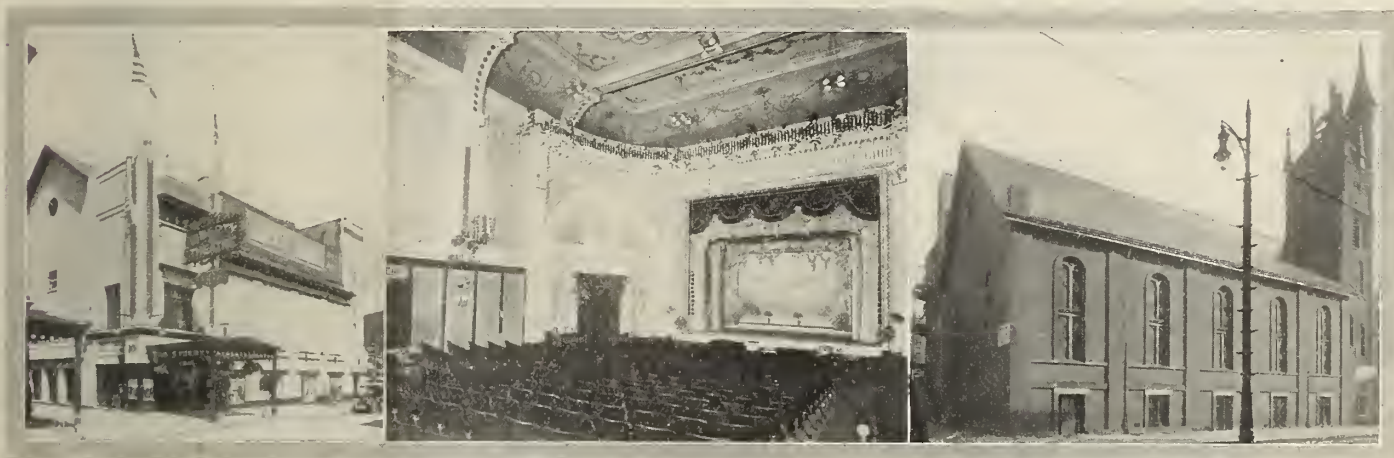

AS IT IS

INTERIOR OF THE LIBERTY

AS IT WAS

dows bricked up, and the entire exterior of the building covered with cement plaster. At the point where the entrance was to be located a special design was used and a very pleasing effect obtained with the use of green tile, marble and imposing electric lights.

The marquee, built of iron and glass, extends to the curb and instead of the usual small center box office, a large roomy one has been provided at the side. Ample space has been provided for posters of all sizes, and this space is so arranged that plenty of advertising can be obtained without unduly blocking up the entrances and covering the fronts of the theatre with unsightly frames.

The theatre has a seating capacity of over seven hundred and the interior is very high and spacious, as it was found to be more economical to retain the old church ceiling height than to lower it by putting in a false ceiling. This arrangement makes the theatre ideal in summer and it is very cool and refreshing to sit in the Liberty and feel that there is lots of air for everyone.

freshing looking in a theatre decorated in this way and with the aid of small incandescent lights studded in the flowers the effect is beautiful.

Rich green carpet covers the foyer and aisles, and these aisles are lighted up by special fixtures which are attached to the sides of the end chairs. This is something that all modern theatres of this kind should have, for the reason that 90 per cent. of the time they are practically dark, at any rate, so it seems to the patrons entering the auditorium from the bright lights of the lobby while the performance is in progress. This aisle illumination prevents stumbling and in no way does it affect the pictures or stage.

The operating room is located directly over the lobby and is of large and roomy dimensions. This room is well ventilated and has sufficient space for installing all the apparatus that is necessary in a room of this kind.

The manager's office is so located that an excellent view of the stage and theatre can be had from this point. He is also

(Continued on page 116)

Projection

CONDUCTED BY HERBERT W. ANDEM

The Operators' Wire Gauge And Its Use

AMONG questions asked of motion-picture machine operators taking examinations for licensed operator, is to gauge wires. Many fail to have gauges of their own, borrowing or hiring one for the occasion.

It is not essential for candidates now to have gauges. Nevertheless it is a wise thing for them to possess one. Perhaps one-half will not know how to use the gauge properly when given a gauge to use. Some may pass successfully, failing in this one point. The question in itself is not of sufficient weight to turn a candidate down when he is qualified otherwise. But, have many successful candidates deficient in this point found out afterwards how to use the gauge properly? A brief review on this subject is well worth a moment's time.

Unfortunately various standards of gauges have been adopted. The only one the operator need to acquaint himself with is the American Standard or Brown and Sharp, commonly expressed as the B. and S. gauge.



FACSIMILE OF OPERATORS' B. & S. WIRE GAUGE

Wires are designated by numbers, representing the diameter of the wires in thousandths of an inch, or mills. Its sectional area in circular mills. A mill is equal to 1/1,000 inch; that is, 1 mill = .001 inch.

Circular Style the Best Gauge

The best gauge to use is of the circular style, as represented in Fig. 1. On one side numbers from 5 to 36 are stamped, corresponding to the sizes of wires. On the other side are numbers giving their decimal equivalents in thousandths of an inch, or mills.

To determine the size, or number of a wire, the gauge is slipped over the wire, trying the several slots, until one is found to just touch the wire on each side. That is, the wire will not go into the next slot bearing a number less than the number on the slot the wire has been found to pass into without any feeling of "looseness."

The round holes are not for the purpose of gauging wires. They are there for mechanical reasons in construction of the gauges. The straight openings only are to be used for gauging. There are many that do not this and try to gauge a wire by putting it in the round holes, and even then do not remove any insulating covering the wire may have over it.

The number opposite the slot that "just pinches" the wire passing in it is the number or size of the wire. Turn the gauge over and reading the corresponding diameter, given decimally, the area in circular mills may be found by multiplying this number by itself. For instance, a wire is tried and found to just go into the slot stamped 6 on it. It is therefore a No. 6 wire. Turning the gauge over, we find .162 stamped opposite this same slot. The wire is then .162 of an inch in diameter, or 162 mills. And $162 \times 162 = 26,244$ circular mills.

Gauging of Stranded Conductors

Stranded conductors have to be gauged a little differently. Any one of the several wires is gauged as explained for a solid single wire. Then the size of a stranded conductor is the sum of the individual wires expressed in circular mills. For example, one strand is found to be No. 14, equivalent to 64 mills diameter. Then $64 \times 64 \times 7 = 26,244$ circular mills for a stranded conductor having seven wires.

This stranded conductor of seven No. 14 gauge wires has a current-carrying capacity, for rubber insulation, equal to a No. 6 solid wire, as given above. This size of copper wire is approved for motion-picture machine circuits. Operators should have this fact well in mind and remember these three figures. No. 6 size wire has an allowable current-carrying capacity of 50 amperes, and its area of 26,244 circular mills, or more exactly and a number more easily remembered, 26,250 circular mills.

This size of wire, namely, No. 6, should never have a fuse to protect it from over heating greater than 50 amperes. There is no danger, however, if a fuse of a less number of amperes is used, provided this smaller size fuse has a sufficient rating and a little above the number of amperes being used. The voltage stamped on the fuse casing makes no difference as to its protecting value, if it is in excess of the voltage being used.

It is also worth while to know the types of insulation used on copper wires. The several insulating coverings are designated in the trade by rubber-covered, slow-burning weatherproof. For iron conduit, only rubber-covered wire may be used. It should also have for pipe work two braids woven over the rubber.

Watch for Tinned Coating

If it is to be used in open work on insulating knobs, or cleats, one braid only complies with the National Electrical Code rulings. As a quick indicator to tell whether the copper wire has a rubber covering, bare the wire from its insulating cover for a short length at one end, say about one-quarter of an inch, and, without scraping the wire, see if it has a tinned coating. The tinning of the copper is necessary to prevent the sulphur in the rubber from corroding the wire. When the wire has the appearance of copper only, under its insulating covering, it generally can be said to have one of the other than rubber insulations; viz., weather-proof or the slow-burning coverings.

Another Means of Economy

WHEN the European war was a certainty many of the exhibitors and exchange managers made an effort to secure all the available imported carbons that they could purchase at the regular price. Many were satisfied to pay more than the normal price because it was evident that there would be a shortage in this necessary commodity and that the article in a short time would be selling at a premium.

A clear picture

is as essential as a good scenario. Because the basic product is right the clearest pictures are on Eastman Film. Identifiable by the stencil mark in the margin.

EASTMAN KODAK CO.,
ROCHESTER, N. Y.

**Pictures That Help The
Box Office**

Next to the story told, the quality of the picture is what draws patrons to your door. Good film service controls the first point—good lens equipment in your machine has everything to do with the last. You can protect yourself best by using

**Bausch^{and} Lomb
Projection Lenses**

Bausch & Lomb objectives are scientifically computed to illuminate the entire picture to the corners and show up every detail clearly.

Regularly supplied with Edison and Nicholas Power Machines and procurable at all exchanges.

*Send for our interesting free
booklet for owners and operators.*

Bausch & Lomb Optical Co.
569 ST. PAUL STREET ROCHESTER, N. Y.

The Rex Film Renovator

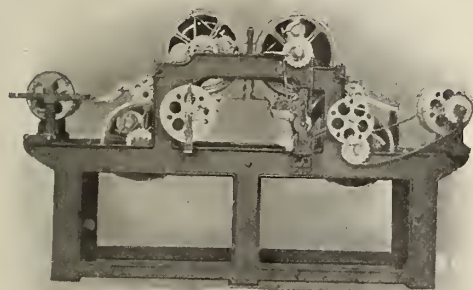

PATENT PENDING

It is now successfully operating in three of the Laemmle Film Service Offices, working day and night, located at

No. 204 W. Lake St., Chicago, Ill.
No. 1122 Farnum St., Omaha, Neb.
Nos. 311-319 Hubbel Bldg., Des Moines, Iowa.

If it is good enough for Laemmle Offices, why is it not good for any other exchange?

Twenty-two other leading Universal, Mutual and Warner Exchanges have one.

The midget Cleaner and Noiseless Rewinder is a dandy; no more horrible noise in the operating booth while show is going on to annoy your patrons. Every Exhibitor and small exchange should have one.

Write for booklet, "Creating Good Will," which also has the best film Cement Formula. It is free.

The Rex Film Renovator Mfg. Co.

272 N. Third Street Columbus, Ohio

WE RENOVATE FILM. WRITE FOR PRICES.

**MOVING PICTURE THEATRE
MAILING LISTS FOR SALE**

20,192, covering United States and Canada, Price \$40.00, or \$3.50 per thousand for such states as you want.

- 795 Film Exchanges, U. S.\$3.50
- 70 Manufacturers and Studios, U. S..... 1.00
- 34 Moving Picture Machine Mfrs. and Dealers..... 1.00
- 231 Film Exchanges, Foreign Countries..... 3.00
- 520 Moving Picture Theatres, Foreign Countries.... 3.00

Ask us for full particulars.

TRADE CIRCULAR ADDRESSING CO.

166 West Adams Street, Chicago
Established 1880

We Can Equip Your Theatre Complete

We are Distributors for the Powers, Edison, Motiograph and Simplex Machines, and Genuine parts, also Poster Frames, Indirect and Semi-Indirect Lighting Fixtures, Tickets, Screens, etc.

We sell for cash or on the easy payment plan.

Write today for our new catalog just off the press.

AMUSEMENT SUPPLY CO.

160 No. Fifth Avenue Chicago, Illinois

Novelty Slides

XMAS SLIDES

PHOTO PLAYER SLIDES

STOCK ANNOUNCEMENT SLIDES

WAR SLIDES

SONG SLIDES

Write for Complete Catalogs

Novelty Slide Co.

67 West 23 St., New York

This has come true and at the present time imported carbons are 300 per cent. higher than they were three months ago and those made in this country have also taken a jump in price.

With an article so necessary selling at such an increase it brought to the minds of many the waste that exhibitors have shown previously and some way in which this unnecessary waste of 40 or 50 per cent. of a carbon could be eliminated.

This waste has been overcome by the Carbon Economizer which was invented by Claude Talley, former manager of the Regent theatre, New York City, and president of the Regent Theatre Company. Mr. Talley conceived the idea of the Carbon Economizer when trouble first started among the European powers, and at that time he applied for a patent on the device.

Made of Brass Composition

The Carbon Economizer is made of a brass composition. This is a good conductor, will stand excessive heat and will not increase resistance. They are $3\frac{1}{2}$ inches in length, $1\frac{1}{4}$ inches is allowed for support in the jaw of a lamp, the other $2\frac{1}{2}$ inches to hold the carbon.

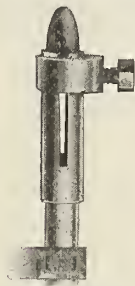

CARBON IN POSITION

The device is made in $\frac{1}{2}$ inch, $\frac{3}{8}$ inch and $\frac{3}{4}$ inch sizes, is round to give perfect contact, and will burn a carbon from 6 inches to $\frac{3}{4}$ of an inch. The section that holds the carbon is split in the center on both sides to allow for tension on the carbon and will spring back when the tension is released to remove the carbon.

As the carbon burns the tension can be released, the carbon moved up until it is held by $\frac{1}{4}$ of an inch and then burned until it is from $\frac{1}{2}$ to $\frac{3}{4}$ of an inch from the end of the Economizer.

In order that the tension screw will not come in contact with the carbon and consequently weld to the body of the device, a collar fits around the top of the economizer which is pinned to the body; the screw passes through this collar to the outer portion of the body.

When the screw is turned it presses the walls of the economizer together and holds the carbon firmly in the container until the screw is loosened. The tension screw is made to allow for expansion of the metal under heat and can be turned without injury when red hot.

The Carbon Economizer can be used a long time if not abused, for it is mechanically correct. It can be used for either upper or lower carbon and will prove to be a great saving on an exhibitor's carbon bill.

This Economizer is being used mostly for burning the carbons shorter after they have been used as much as possible under ordinary conditions. It gives complete satisfaction.



ECONOMIZER AND CARBON STUBS IN POSITION.

SAVE 35%

on your

CARBONS

Burn your stubs with a

CARBON

Economizer



Pat. applied for.

Fits any lamp, gives perfect contact and conductivity made of special material, screw does not come in contact with carbon and will not weld to body of economizer; will burn upper or lower carbon to $\frac{3}{4}$ of an inch.

OVER 1000 IN USE

"MECHANICALLY CORRECT"!!

Guaranteed to give satisfaction

\$1.25 Each. Sizes $\frac{1}{2}$ " - $\frac{3}{8}$ " - $\frac{3}{4}$ " Set—any sizes. \$2.00

Sent postpaid upon receipt of New York Draft, Money Order or Cash.

THE CARBON ECONOMIZER CO.

757 W. Onondaga St. Syracuse, N. Y.

Milwaukee Operators Celebrate Thanksgiving

Special to MOTION PICTURE NEWS

Milwaukee, Wis., December 2.

THE Motion Picture Operators' Union No. 164 of Milwaukee, Wis., gave their first annual Thanksgiving party at the Freie Gemeinde Hall, Wednesday, November 25. It was a novel affair, held between 11 P. M. and 3 A. M. A representative crowd was in attendance and many unusual features were supplied by the committee in charge of the affair. Those on the entertainment committee were John Black, C. Colter, Nick Delorenzo, F. Lower, George Witteman and Arthur Weaver.

The affair proved such a success that the organization will arrange next year to hold another Thanksgiving ball.

Plans are also under way for an Operators' Masked Ball to be given at the Auditorium some time in February.

Dan Cupid has evidently picked out the local operators as his special victims in the last few weeks. For this is the only way in which the wholesale marrying among the operators that took place the first week in November can be explained. No less than three operators fell victims to the darts of the sly little God of Love in that week. They were Elmer Klase, the chief operator at the Strand, and George Witteman and Walter Klein at the Modjeska.

Be sure to mention "ACCESSORY NEWS" when writing to advertisers.

SAVE 5 DAYS

Have your prints made and Shipped from

LOS ANGELES

Direct to your exchanges.

Process invented by an European cinema scientist, used exclusively in our plant, gives us extraordinary facilities for

—**SPEED**
—**DETAIL**
—**TINTING**
—**TONING**

Every print perfect.

Every order finished at the time promised.

INTERNATIONAL LABORATORIES

3123-25 So. Hoover St.,
Sunset Phone West 792
Los Angeles

CLASSIFIED

FOR SALE

Five Powers' Machines, one 3-reel feature, one 2-reel feature, for sale, cheap. No reasonable offer refused. Exhibitors, R. 403, 110 W. 40th St., New York.

FILMS FOR SALE

500 Single Reel Subjects, all popular makes, comedies, dramas, etc., full and split reels, in A1 condition. J. B. O. Feature Film Service, American Theatre Bldg., Milwaukee, Wisconsin.

CAMERAS FOR SALE

2 Moving Picture Cameras, complete with Lenses and Tripod, Perforator and Printer. Will sell cheap. J. B. Olinger, American Theatre, Milwaukee, Wis.

HELP WANTED

Local representative in each State to handle exclusive State Right Features on percentage basis; bond required. J. B. O. Feature Film Service, American Theatre Building, Milwaukee, Wis.

AT LIBERTY

Experienced Exchange Manager, thoroughly acquainted with renting conditions, Chicago territory. If you can offer live wire proposition, address Phil H. Solomon, 5744 Indiana Ave., Chicago, Ill.

DO YOU WANT a theatre manager? One who has managed four other large theatres and knows from experience, all the details of profitable booking, effective presentation, advertising, efficiency among employees, projection, theatre personality. If you want loyalty, business ability, brains and energy to manage your theatre, address M. H., care Motion Picture News.

What Do You Need?
CONSULT ACCESSORY NEWS

Problems That Puzzle Projection People

O. L. D., Rye, N. Y.—What is the difference between moving pictures and motion pictures? What is the thing called a zoetrope?

ANSWER.—(a) Obviously the same meaning is intended to be conveyed by these two terms. Motion pictures would seem to be the better form of expression to use to properly express a reproduction of motion by means of pictures. That is, motion reproduced within the picture. The picture itself does not move when being seen. The other expression—moving pictures—is very expressive, and may convey the idea also that the pictures themselves move.

When the reproduction is faulty, or imperfect, from the picture not being steady on the screen, this expression is the more apt one. Animated pictures was a term used in past years. Living pictures were popular then also, and this word animate means to make alive—to enliven, confused the minds of some. Paying the price of admission to see living pictures, as they thought, they were firm in their demands for refunding the money.

The Wheel of Life

Hence, the good reason for not continuing the use of this word for this branch of photography. (b) Zoetrope, or wheel of life, is the word used for the toy to amuse children and has been for sale in the toy shops for years. The initial principle of moving images was suggested by this simple toy. Not until the celluloid film was perfected and placed on the market did this idea of motion in pictures, so long known to be possible of solution, make any advancement. This little toy was all.

It is made of a cylinder of cardboard, about ten inches in diameter, open at the top. Around the lower and interior rim is placed strips of paper, having drawn on them, by hand, pictures related to each other by separate phases in positions of motion. The cylinder is rapidly revolved by a touch of the hand, and the eye of the spectator is directed to the narrow and vertical slits made in the upper rim of the cardboard cylinder. One then sees the pictures assume motion from the rapid succession of the individual pictures conveyed to the eye through these slits.

The toy is easily made and is inexpensive, except the drawing of the pictures. The drawing of these pictures should afford the operator much amusement and advance his knowledge of motion picture phenomena. The film subject "Heezaliar—a Farmer" shows how one mind has developed hand-drawn pictures. To see a reproduction of this film is worth a hundred times the price of an admission ticket.

B. U. M., London, O.—To decide a bet, will you kindly tell me if it is possible to hold an inflammable film still, without the machine being in motion and the fire-shutter raised, and not have it catch fire from the light striking on it? What makes a film catch fire if this is possible?

ANSWER.—(a) As strange as it may seem, this is possible under certain conditions of the film. This fact was stumbled onto when a fire marshal was having exhibited to him the possible chance of

fire from a film catching fire when standing still in a machine and the light on it. The film was threaded in the machine, putting the end, or spacer, in first. This spacer was a piece of film without any pictures on it. This is used to join short lengths of films to make up a reel. Much to the surprise of the demonstrator, the film did not catch fire.

What Can Be Done with a Film

It is possible to have the light on a clean, clear celluloid film (remember the three "Cs," not "Rs"), and not have the film catch fire, even for a space of time. (b) When there is any color, or black coating, on a film, the light is prevented from passing through. This is necessary to produce the picture on the screen. The high lights—no color or coating—and the shadows—deep coating—produced by photography on the film.

Then what happens to this light prevented from passing through the film medium? You cannot destroy matter. There always has to be a balance. Light and heat are very closely related. One is generally present when there is the other. So they both appear as heat and are absorbed till the temperature is at the igniting point of celluloid. In only a few seconds' time it reaches this point.

In the case of the clear celluloid, if only a small area is covered with a little ink, this point will then become heated and catch fire. Films that have photographs of rooms or interiors with dark colored walls or backgrounds, are subject to fire in a higher degree than the films of outdoor scenes with large sky areas of uncoated surfaces.

M. D. S., Cohoes, N. Y.—Does it make any difference if the condensing lenses are put with the curved surfaces turned out? Are short focus lenses more liable to crack than long focus lenses?

ANSWER.—(a) Yes. There have been many attempts to improve the arrangement of the condensing lenses. The two lenses with the curved surfaces turned towards each other and inside of the mounting, has not been improved by any other arrangement of them. (b) Short focus lenses are more sensitive to changes in temperatures from the fact of being thicker at the center than longer or less curved lenses. Short focus lenses are therefore more liable to crack from any cold air striking on them when opening the door to trim the lamp. Lamp houses allowing of the lamp to be withdrawn from the back are to be preferred to those that have the side door only.

News of California Theatres

The Majestic theatre, Redlands, Cal., has been sold by J. A. Menard to W. Clyde Henderson, who has taken possession.

Beginning Monday, November 30, The Century theatre, 523 South Main street, Los Angeles, became a motion picture house, contract having been made for Mutual service. The Century has 900 seats and has been the home of comic opera stock company for the past few years. By this change the Optic theatre, 533 So. Main street, loses the Mutual program.

**MANY EXHIBITORS HAVE PROVEN THE FACT THAT BY
INSTALLING A MIRROROIDE THEY HAVE
RECEIVED A GREATER PATRONAGE
RESULTING NOT ONLY IN SATISFACTION TO BOTH BUT
ON ALL OCCASIONS THE
RETURNS FROM THE INVESTMENT HAVE DEMONSTRATED
OUR CLAIMS TO THE IMPORTANCE OF PERFECT PROJECTION
IN YOUR CASE HAVE YOU
DECIDED TO SATISFY YOURSELF?
ENROLL AT ONCE IN THE GREAT ARMY OF SATISFIED USERS OF
MIRROROIDE**

SEND FOR SAMPLES, 3 TINTS { SILVER WHITE
SILVER FLESH
PALE GOLD } 2 FINISHES { ROUGH
OR
MATTE } OVER
8000
IN USE

Our Latest Tried—Tested—True Master White—Ready to Apply—The Whitest of the White—It Can't Crack, Peel or Rub Off—It's Fire Proof—Get a Sample of Master White—It Contains no Glue, Whiting or Lime—Be Wise—Deal With Responsible Manufacturers—Avoid the Fly By Nighters.

THE J. H. GENTER CO., INC., NEWBURGH, N. Y. The Oldest—The Only Real Screen Manufacturers With a Factory in the World.

Building and Furnishings

Some Official Hints on Fire Prevention

IN the last Bulletin issued by the State Insurance Department of Michigan, the following articles on "fire prevention" are contained. They are worthy of consideration by motion picture theatres, and could be used very advantageously by proprietors and managers who get out weekly programs by reproducing them:

KEEP EXITS UNLOCKED

Section 5 of Act 257 for the regulation of moving picture theatres provides that all exit doors must open outwardly, and shall not be locked where the building is open to the public. Recently a representative of the State Fire Marshal's Bureau discovered the exit doors in a Michigan theatre locked during a performance and promptly caused the arrest of the manager.

On June 18 a fire which originated from a moving picture equipment destroyed nearly all of the village of Dollarville, Luce County.

On October 22, a conflagration which started from a moving picture outfit burned to the ground more than half of the village of Walkerville, Oceana County. A village situated a considerable distance from any railroad and so remotely located that the State Fire Marshal's Department had not been informed of or been made acquainted with the fact that moving pictures were being shown there.

In both of these instances the moving picture outfits which caused the trouble had not been either inspected or approved by the State Fire Marshal's Department, according to law.

An investigation made by a representative of the State Fire Marshal's Department of the Walkerville fire shows that the exhibition was being given in a second story hall contrary to Section 4 of Act 257, of 1913, which prohibits the locating of shows of this kind in any except first-story halls. The operating booth was not constructed according to law, and the entire hall and equipment presented a dangerous menace to the village.

The fires at Dollarville and Walkerville demonstrate two facts: First, chiefs of fire departments, township clerks, owners of theatres and patrons should notify the State Fire Marshal's Department when moving picture exhibitions are being given without the proper approval of the department.

Second, every moving picture theatre or exhibition is a fire menace, unless it conforms to the law, and should either meet with the requirements of the law or be put out of business.

THE PATRONS' DUTY

The moving picture theatre managers of Michigan are compelled by law to have their places equipped and arranged according to certain fixed rules and regulations and to conduct them according to the provisions of the same law. How about the patrons? They at least should be governed by a law of common sense. In most cases where there has been loss of life in theatre fires it has been due largely to panic and not to fire. When a fire is discovered people lose their heads. Here are a few simple suggestions:

If some one yells "fire" in a theatre, or you suspect that there is a fire make sure that there is one before you try to get out of the building. Don't run and scramble when you start to leave the building, but keep your feet and your head. Always learn where the exits are located when you first take your seats and when you try to leave the building use a regular exit and not either a window or perhaps some door which is not an exit at all. Don't try to beat

everybody else to the exits, for you cannot all get through the door at the same time anyway. Remember you are a human being and don't fight and try to save your life whether anyone else is saved or not. Don't stand up and yell "fire" unless you know there is a fire.

A "Small Town" House That Measures Up to "Big Town" Standards

IT is seldom if ever that one can go into a town of 9,000 inhabitants and find a theatre seating close to one thousand people, a house which can be compared favorably with the largest theatres in the country's metropolis, that is playing pictures at ten cents.

Such a house is the Auditorium theatre at Waukesha, Wis. Though Waukesha is a small town, its theatre-goers have big town ideas, and the electric line to Milwaukee has placed its exhibitors in almost direct competition with the Milwaukee exhibitor. It is only an hour's ride to Milwaukee, and if an exhibitor wishes to succeed, he must keep his house and shows up to the Milwaukee downtown standard.

This probably is why Manager George B. Frelson has been so successful. The house is modern in every respect. It was built this year and is owned by the Frelson Amusement Company, which is controlled by George B. and Gustave Frelson.

The theatre, 50 x 150 feet, has a most spacious and artistic lobby. The display fixtures are frames, indented in the wall, with a border of electric lights illuminating them. From the lobby one steps into the foyer, completely cut off from the theatre proper by a plate glass partition with doors on each aisle.

There is but one floor, with seats for 914. The decorations are most tasteful, being in old rose, ivory and gold. The lighting is the indirect system with direct lighting side brackets. The seats are in keeping with the general decorative scheme and are all leather-upholstered and most comfortable and spacious. Music is furnished by a four-piece orchestra.

The ventilating system, which was installed by the Milwaukee Corrugated Company, is the same that has been adopted by the United States Government, and it keeps the theatre sweet and dry at all times.

The operator's booth, in charge of Benjamin Shock, contains two Motiograph machines and mercury arc rectifiers. The throw is 120 feet to a specially prepared quartz screen. Two shows of four reels each are given a day, the General Service being used.

Though Waukesha has no daily paper, every method that is open to him is used by Manager Frelson to boost his house.

\$60,000 Quaker City Theatre Nearly Ready

WHEN it comes to new motion picture houses, Philadelphia deserves not its reputation of a slow town.

Rather is it in the vanguard of the procession. Among several now building, a notable addition to the field is the "Tioga," almost completed—in fact, this up-to-the-minute play house will be opened on Christmas day.

The Tioga is owned by the Tioga Realty Company and will cost in the neighborhood of \$60,000. Sauer & Kahn, 1112 Chestnut street, Philadelphia, are the architects and have put into the house some very new and original ideas.

It will be one of the largest in the city, with seats for about 2,000 people.

New Harper, Detroit, Will Open December 1

THE new Harper theatre, at Woodward avenue and Harper avenue, Detroit, was ready to open December 1. It accommodates about 400 persons. Alvin D. Hirsch, attorney at 329 Majestic building, is the proprietor. A Masterlite Screen and a Powers machine have already been installed. Although small, it is one of the prettiest and coziest playhouses in the city.

MENGER & RING

302
W. 42nd
Street
New York

TELEPHONE
BRYANT 6621

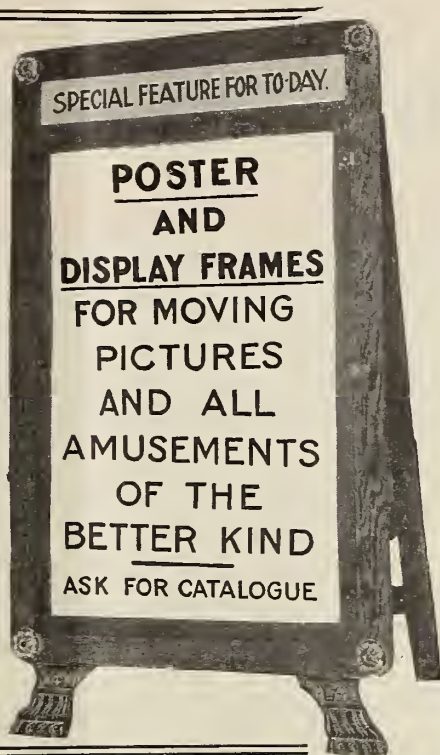

Mr. Exhibitor!

¶ We know that one of your greatest problems is how to keep your attendance and receipts up above the average.

¶ At no expense whatsoever you can become acquainted with the neatest, cleanest and most exclusive business builder ever offered to a motion picture theatre owner or manager.

¶ We are daily receiving testimonials from satisfied exhibitors all over the U. S. and Canada.

¶ Fill in coupon below and send it to us today.

Wyanoak Publishing Co.
136-146 W. 52nd Street, New York, N. Y.

COUPON

Wyanoak Publishing Co.,
New York, N. Y.

Gentlemen:

At your expense send complete information regarding your Business Builder, to

Name

Address

City

PERFUMES DISINFECTANTS

SPRAYING DISINFECTANTS.

BOUQUET, 1 gal., \$2.50; 5 gal., \$10. Our best. Cannot be equaled in strength and fragrance.
LAVENDER, 1 gal., \$2.00; 5 gal., \$7.50. REFRESHING.
SPEARMINT, 1 gal., \$1.50; 5 gal., \$5.00. POWERFUL.
PRICES INCLUDE LARGE SPRAYER.
50 cent. credit without sprayer.

PERFUMES.

Can be used with Fans or in Clay or Plaster Paris Cones.
Cinnamon \$2.50
Spearmint 3.50
Lavender 3.50
Carnation 6.00
Bonquet 6.00

CONES 30 cents
each.

YOUR MONEY REFUNDED IF NOT SATISFACTORY

We sold the first perfumed disinfectants in this country, and on account of manufacturing and importing direct, the quality at our price cannot be hoat.

GENDISCO

408 36th Street - BROOKLYN, N. Y.

10% May be deducted from above prices on any order no matter how large if check is sent together with this Coupon.

Offer only good up to January 1, 1915

Please send me the following.....

.....

.....

.....

Less discount of 10%.

Name..... Theatre.....

Address

Directory of New Theatres

EDITOR'S NOTE.—The information contained in the "Directory of New Theatres" is gathered by the field representatives of "Motion Picture News" and the facts and figures in each instance have been verified by them and are authentic. They may be relied upon by members of the trade.

Eleventh Allentown Theatre in Operation

ALLENTOWN, Penna., now has its eleventh moving picture theatre since the new "Franklin," on Tilghman street, near Fourth, was opened to the public Thanksgiving Day. This theatre is one of the prettiest and safest moving picture theatres in the city. The theatre is owned and operated by Frank F. Seiberling, of No. 604 North Sixth street, Allentown, former proprietor and present owner of the Forest Inn, located eight miles east of Weissport, Pa.

The building which was erected and furnished at a cost of about twelve thousand dollars, has been in the course of erection for almost a year. It is a single story building with a large shell front effect. The rule of "Safety First," has been carried out to the letter in the new theatre. There are seven fire exits and when necessary, the theatre can be emptied in less than a minute's time.

Wood and Concrete Flooring Used

The new theatre has a frontage of 52 feet and is 86 feet deep. It is constructed of concrete foundations with brick side, rear and front walls, laid in cement plaster and finished in white coating. The metal ceiling in the auditorium is 25 feet high and has a truss roof which is finished in herringbone concrete. The floor is of concrete covered by wood.

Ladies' and gentlemen's retiring rooms have been built in the front portion of the building. There are also sanitary drinking fountains, and a large business office constructed within the shell in the front. The moving picture booth is of the Johns-Manville type, which is thoroughly approved by the underwriters and the kind used in most of the modern moving picture theatres throughout the country.

In the booth are installed two No. 6-A Powers motion picture machines of the latest style.

The interior of the theatre is all in a pure white body with a pale green border, with the woodwork all mahogany. One of the features of the auditorium is the beautiful lighting system. At different points of vantage and suspended from the ceiling are elaborate chandelier electric lights of the indirect illumination system. Little red bulbs are above each fire exit.

Eleven Theatres Now Running in Allentown

The ventilation is of the underground conduit system, such as is used in most of the modern theatres.

With the opening of the Franklin there are now eleven moving picture houses in the city, the Franklin, Hippodrome, Victor, Pergola, Madison, Washington, Temperance, Allen, Palace, Regent and Nedson.

Cincinnati's Strand Has Holiday Opening

THANKSGIVING DAY saw the opening of the Strand, the largest downtown motion-picture theatre in Cincinnati, O. It will be essentially a feature house and its opening marks a new era in the motion-picture industry here. The Strand, which has a seating capacity of 1,550, under the management of Isaac Libson, who has already successfully steered the destinies of two big theatres—the Family and the Bijou—has begun a campaign of newspaper advertising which has placed it on a par with the legitimate houses, as far as publicity is concerned.

This means that advance notices and reviews of its pictures will be printed in the columns devoted to theatrical news in the Cincinnati papers. Exhibitors in charge of the larger theatres of the city are preparing to follow the lead of the Strand in case its policies should prove of material value.

In connection with its newspaper advertising campaign, the

management of the Strand has added a press agent to its corps of employes, and the results so far have seemed ample to justify the expense. The first move of the press representative was an invitation to all newspaper men in the city to attend the opening performance.

The theatre, which was constructed only a year ago as a burlesque house, has been transformed throughout. The scheme of decorations and lights has been changed to harmonize with the pictures, and a \$20,000 Wurlitzer organ has been installed. This organ is similar to the one which has been used by Libson for some time past in the Family theatre, where its music has been one of the attractions.

\$50,000 Theatre Started in Jackson

A \$50,000 theatre is to be erected at once on the fifty-foot strip of property just west of the New Majestic motion picture house, Jackson, Miss., by John Livelar, of Canton. This statement was made by Houston Bowers, manager of the New Majestic, who will be associated with Mr. Livelar in the management of the new playhouse.

The work of tearing down an old frame structure on the property has begun, and as soon as the contract for the new building is let work on the erection of the new opera house will begin.

It is planned to erect a two-story building, with a frontage of fifty feet. The plans call for a theatre building that will accommodate the largest dramatic attractions, in addition to motion picture programs.

The new theatre will have a seating capacity of between 1,500 and 2,000 people. Whether there will be one or two galleries has not been decided.

The building will be of brick, highly artistic in decorative features.

When the new theatre is ready for operation the New Majestic will be divided into two store apartments and rented out to retail business firms.

\$60,000 Theatre Promised in Detroit

DELRAY, a suburb of Detroit, is to have another fine theatre that will seat in the neighborhood of a thousand people. It will be a combination theatre, store and flat building, one of the most modern on the west side of the city, costing approximately \$60,000. The owner is John Kaczur, who came to this country about 25 years ago with the clothing that he had on his back and the sum of five cents in his pocket.

It will be known as the Pulaski theatre building, and situated at the corner of West Jefferson and Pulaski avenues. The theatre proper fronts on West Jefferson, the corner store on the two streets, and five other stores on Pulaski street. The six flats are above the store building.

Work on the building is advancing rapidly and it is fully anticipated by Mr. Kaczur that the theatre will be ready by the first of February at the latest. The walls and roof are finished, and all that remains now is the interior work, putting on the final touches and installing the proper equipment.

Old Faces at New Detroit Theatres

EDDIE MURPHY, who tendered his resignation as assistant manager of the Columbia theatre, Detroit, Mich., about a month ago and who went to the Bijou theatre in Saginaw, Mich., will return to Detroit early in December to

Directory of New Theatres

be manager of the new William Penn theatre, at the corner of Woodward and Philadelphia avenues, which is rapidly being completed.

The theatre will be added to the chain already operated by the Calvert Theatre Company, of which David King is president, and Lester Levey, general manager. Mr. Murphy was connected with the Columbia since it opened three years ago.

A. J. Gillingham, proprietor of the New Empire theatre on Woodward avenue, Detroit, has appointed W. H. Smith to succeed B. Harlan Starr as manager, owing to the latter's resigning. Mr. Smith has been assistant at that playhouse for the past six months, having come to the Empire from Albany, N. Y.

T. J. McCarron, son of J. H. McCarron, manager of the Family theatre, has been appointed assistant manager.

Theatres Here and There

THE Forest Theatre on Burnet avenue, Cincinnati, gains where Keith's theatre loses in the person of George Schoettle, former treasurer at Keith's theatre, who has been made manager of the picture house out in Avondale. Schoettle has been in the ticket office of Keith's theatre for fifteen years and knows the ins and outs of the profession.

F. Brown has leased the Lyric Theatre at Pembroke, Ky., from Mrs. J. R. Paine, and changed the name to the Novelty. A new picture machine has been installed and a show is given nightly at five and ten cents admission.

The South End Amusement Company of Louisville has been incorporated with a capital of \$25,000. The incorporators are H. B. Strube, J. M. Keaney, H. C. Peltier and W. C. Dugan. The company is planning to erect a new motion picture theatre.

Work on the construction of the new motion picture theatre in Hollywood avenue, near Long avenue, Elizabeth, N. J., will be started in a few days. The building will be of concrete construction and will cost between \$6,000 and \$7,000.

Plans are being prepared by Carl P. Berger for a one-story moving picture theatre, 130 by 147 feet, to be built at the north-east corner of Germantown avenue and Venango street, Philadelphia, for Mrs. J. Effinger.

W. H. Linton, proprietor of the Hippodrome theatre, Little Falls, N. Y., has purchased from Mrs. Grace the property on Main street now occupied by the Hagar & Haskell lunch room and cigar stand and which extends to the rear of the theatre. Mr. Linton will build an addition, 43 by 50 in size, at the rear of the Hippodrome. The work will be started in the spring. Carl Haug & Sons, the architects, will prepare the plans.

Shakespeare Theatre, Chicago, Is Leased

A noteworthy transaction in Chicago moving theatre property has just been closed in the acquirement by the United Moving Pictures company, G. G. Schoneberg, president, from the Alfred Amusement Company of the lease of the Shakespeare theatre, at the northwest corner of East Forty-third street and Ellis avenue, Chicago, for a reported bonus of \$35,000. The lease has ten years to run and the Moving Pictures company also secured an option for an extension of ten additional years at a reported annual rent of \$8,000.

The Shakespeare theatre was opened last June, has a seating capacity of 1,000, and is one of the best appointed playhouses of its kind in the city. Hume & Co. were the brokers, representing both parties.

It is rumored that James Washington and Chas. Wolters have bought the opera house and film business at Ruthven, Ia., from L. T. Clark.

Mr. and Mrs. J. W. Jeffers opened the Electric Moving Picture theatre at Litchville, N. D., in the old Bowan Hotel building.

The members of the Morningside Heights Improvement As-

sociation of Grand Rapids, Mich., may go into the moving picture business if they can get a lease of the old Curling rink in that neighborhood and if the city council will grant them a permit to do that kind of business during the summer months. The members will all take stock in the company and undertake to get some of the financial benefits that someone else coming to that section of the city might get.

The proposed Keith theatre to be erected in Grand Rapids, Mich., was brought one step nearer in the past few days with the visit to the city of George L. Rapp, Chicago, of the firm of C. W. & George L. Rapp, architects for the western district of the Keith interests. Mr. Rapp went over the various sites which have been given tentative consideration. Mr. Rapp returned to Chicago with the preliminary figures and at once will prepare sketches, estimates and plans for the new playhouse.

Doing of Michigan Theatre Owners

The Gem and Electric Theatre Company, Manistee, Mich., has been incorporated for \$3,500.

Stockholders of the Alhambra theatre, Toledo, Ohio, adjoining the Second National Bank building on Summit street, have incorporated as the Citizens' Alhambra Theatre Company, with a capital stock of \$65,000. The principal stockholders are John J. Gardiner, Fletcher C. Hull and Richard D. Logan.

The Delft theatre opened November 16 with vaudeville and pictures at the popular price of ten cents. The house is leased by the Delft Theatre Company, who recently opened a theatre in Marquette. Lawrence Jacobs is the house manager. The theatre seats 700 people and cost \$70,000.

Mason Hopper, producer of motion pictures, and who has been working in the western part of Michigan for some time with a company, contemplates the erection of a manufacturing plant at Reeds Lake, Mich., which is also to include the erection of a theatre for the staging of the plays.

J. C. Peterson, of Traverse City, Mich., is drawing plans for a moving picture and dance hall to be erected in Frankfort, Mich. It will be of brick and steel, two stories high, 75 by 105 feet in size.

T. A. Fowler, architect, 7 State street, Hillsdale, Mich., is drawing plans for a theatre to cost \$38,000 for C. W. McClave, of the Smith Hotel. It will be of concrete, steel, brick and terra cotta; will be fireproof, three stories high, 62 by 122 feet in size.

It is reported that the Marcus Loew interests are planning to erect a large picture theatre in Grand Rapids, Mich.

Theatres of Kalamazoo, Mich., which opened Sunday, November 22, the first time in seven years, did a thriving business, indicating that citizens are in favor of photoplays on the Sabbath.

\$50,000 Theatre for Logan, Pa.

Horace Groskin has closed negotiations with Theodore M. Delany, representing a moving picture company for a site on Broad, between Ruscomb and Rockland streets, Logan, Pa., upon which the buyers will build a moving picture theatre, seating 1,000 persons. They have had plans prepared and work will be begun upon the building shortly. The cost of the structure and site combined, will be about \$50,000.

There is talk of building a large moving picture theatre in Garfield, N. J. Several managers have been looking the field over the past few days. It is proposed to build a place that will seat at least 600 people, and to get it on one of the main streets, if possible.

Minnesota motion picture theatres generally will aid the sale of Red Cross Christmas seals between now and the holidays. Nearly all of them will run at least once some picture that teaches a lesson in charitable giving, or will show the ravages of tuberculosis. The theatres are looked on as the greatest aids in the campaign.

Music and the Picture

Editor's Note.—This department is prepared to answer all questions from exhibitors relating to the use of music in connection with photoplays, and to suggest suitable music for current pictures. Correspondence will be welcomed

Using the Resources of an Orchestra to Interpret a Photoplay

By H. S. FULD

YOU will have noticed in these columns that my argument has always been against orchestras in theatres for motion pictures. But I will have to retract a bit. I have seen and heard a large orchestra, wonderfully handled, rehearse the musical accompaniment for a five reel picture. Try if you can to imagine an orchestra of twenty-one pieces, follow a picture scene by scene, carry a theme through the entire production, varying the tempo and so on, and really carry the story as it were with melody.

I had heard of the Strand Theatre and its wonderful orchestra under the direction of Carl Eduarde, but as I could never quite grasp the idea of an orchestra playing for the picture, I was under the impression that it was no different from the average theatre with an orchestra, with the probable exception of the music being better rendered. To say that I was astounded would be putting it mildly.

It is the custom of Mr. Rothapfel, the manager of the Strand, to have a rehearsal every Saturday morning, where he personally selects and arranges the different musical numbers to be played the following week for the accompaniment of the picture. It is wonderful, to say the least, to see how and with what apparent ease these scores—and they are truly scores—are arranged. One of the most remarkable facts, if not the predominant one, is that here this large orchestra works with him as though it were a piano player alone.

Mr. Rothapfel paces up and down the floor of the stage, giving directions in a short, snappy tone entirely foreign to his "office behavior." The picture is on the screen and he has a telephone in his hand with which he is constantly in communication with the operator. His stenographer sits at one side of the stage taking down his suggestions, the changes as he directs them in the music, and the fast or slow orders as given to the operator. Watching all this is so fascinating that one is apt to forget that a rehearsal is in progress, but the sudden stopping of the picture for a change from, or repetition of, the selection then being played brings one back to earth as it were. Here a little is added, there a little taken away, here a little slower or a little faster, until the music just dovetails, as it were, into each scene.

At the afternoon performance the next day the music flowed without a hitch or pause as though it had been rehearsed for weeks—never a false move, and to think that this can be done with but two and a half hours' preparation the day previous, and with an orchestra of twenty-one.

The picture that is mentioned in this article is Lasky's "Rose of the Rancho" in five parts, and the theme that is prominent throughout the entire musical accompaniment is "Drigo's Serenade," and selections from "Carmen" are continually in evidence.

The idea of having a theme carried through an entire production has been advocated in these columns over and over again, but Mr. Rothapfel goes us one better.

He has done what on first thought seemed impossible. These columns have spoken often enough on the proper accompaniment of the picture, fitting the music as it were with each scene separately, and if necessary to improvise. But always the pianist, or Wurlitzer, or other one-man orchestras were in mind; never was an orchestra, especially a large one at that, deemed capable of so doing. To illustrate:

In "The Rose of the Rancho" the theme as previously men-

tioned in "Drigo's Serenade," and into every scene in which Kearney, of the U. S. Government Service, appears with Juanita, daughter of the Rancho, this melody is prominent. As the other scenes intervene the melody is subdued, with counterpoint or counter melody, thus carrying the story, as it were, by linking the scenes together. The theme being identified with Kearney and Juanita, the idea that they are to be always thought of as being in love and helpless when separated is always in evidence.

Rothapfel from the notes of his stenographer arranges a sort of time-table or schedule, or score—call it anything you will—and this is what is used for the picture's accompaniment. Just as an instance appended here is a transcript from Rothapfel's score for the photodrama.

Play "Middleton Book," No. 4 (a musician's score book) until title "Lieut. Larkin of the California militia";

No. 5, "Middleton Book," until "Miss Bessie Barriscale as Juanita, daughter of the Ancient House, etc.";

"La Paloma"—D. S. until "Espinoza hasn't registered, you copy the boundaries";

"Carmen" from letter G until Kinkaid walks into dining room.

Introduction from "Carmen" until action commences;

Hurry No. 33, "Middleton Book," until girl stabs herself;

"Carmen" from after Letter F until half-breed laughs and exits;

Hurry No. 33, "Middleton Book" until Senol, the Indian, enters bedroom;

"Carmen" after letter F again until Indian staggers out of room; and

Hurry No. 33, "Middleton Book" until Rose of the Rancho takes her morning outing, and so on.

The numbers and letters refer to the numbers and letters in the "Middleton Book."

The foregoing article you must remember deals with an exception. There is in all probability no other theatre that has an orchestra playing the pictures in this inimitable manner. In the first place the orchestra must act as a unit and be capable of grasping the ideas of its director on the instant.

Secondly, it means lots of practice, but most of all it absolutely requires a master musical mind to direct it.

Theatres that use a picture for a week and have an orchestra that is half way competent would do well to send a representative to one of the Strand theatre's rehearsals, see how the music is fitted to the picture, have a talk with Rothapfel and get his ideas.

Of course where the one-man-orchestras are in vogue this method of "playing to the pictures" is not alone possible, but it is the *only* way that the music should be rendered.

Tell the story of the picture as it were with the music. Fit in a song or theme where the words or even the melody will fit the unspoken words or the action on the screen. Avoid the long, classical selections that will run through numerous scenes without any possibility of being appropriate or in any way fitting to the action on the screen.

It cannot be advocated any too emphatically: *Change your music with each change of action.*

To explain: The scene now on is a Spanish love scene; the two lovers are in the garden; you are playing "Senorita"; the next scene shows the soldiers in the barracks for probably two or three minutes, and then reverts back to the garden scene. The moment the barrack scene appears break away from the melody with counterpoint and back again when the garden scene appears. *Try and make your music fit.*

Day and Date	Titles of Films Booked	Release Date	Brand	No. Reels	Review appears in Motion Picture News of		Posters Used and Size	Regular or Special	Cost	Advertising Used: Newspapers, heralds, slides, photographs, window cards	Weather	Total Admissions	
					Issue	Page						Matinee	Night
MONDAY													
											Remarks		
TUESDAY													
											Remarks		
WEDNESDAY													
											Remarks		
THURSDAY													
											Remarks		
FRIDAY													
											Remarks		
SATURDAY													
											Remarks		
SUNDAY													
											Remarks		

Make Your Lobby Display Attractive

There is nothing more fascinating to the public than a bright brass frame to display your photos or posters.

We make Lobby and Theatre Fixtures and Brass Rails of every description.

Don't fail to visit our Showrooms. Write for catalog.

THE NEWMAN MFG. CO.
717 Sycamore St., Cincinnati, Ohio
Branch Factories and Show Rooms:
101 Fourth Ave., New York, N. Y.
106-108 W. Lake St., Chicago, Ill.
Established 1882.



Making a Church Into a Successful Theatre

(Continued from page 105)

in direct communication with the operating booth, which is located right next to his office.

This theatre has a stage 14 feet in depth from the curtain line back, which is fully equipped in every particular, including a large stage switchboard, which controls all the lights, both in the auditorium and on the stage. The theatre is so wired so that the entire auditorium can also be controlled from the operating room, thus doing away with all employees on the stage, when pictures only are being shown.

Suitable retiring rooms are provided for the ladies, and sanitary drinking fountains are installed in the lobby.

This building was remodelled and opened to the public in three months from the date that the contractors began work, and from the beginning enjoyed success.

A sprinkler system is installed over the stage, and the dressing rooms, which are located above the stage floor, at the side, are also equipped in a like manner.

A vacuum cleaning plant is one more detail that has been added to make this theatre one of the most complete of its kind.

The theatre is fifty by one hundred feet, and all the material used in its construction is fireproof, such as brick, concrete, hollow tile, metal lath, and plaster.

There are forty box seats, and the two projection machines have a motor control. The length of the throw is about ninety feet. The seats were furnished by Heywood Brothers and Wakefield. A Gold Radium fibre screen is also part of the equipment.

Besides a large pipe organ, music is furnished by the aid of a six-piece orchestra. Hillgreen, Lane & Company, Alliance, Ohio, are the makers of the instruments.

Paramount pictures are shown, and six shows a day are given.

The admission is ten cents at matinees and ten, fifteen and twenty at night. The theatre is located in the heart of the business district.

C. Howard, 2321 Dime Savings Bank building, Detroit, is the architect.

Enterprise Machines in California

THE Enterprise Optical Manufacturing Company reports these recent California sales:

Sperry Flour Company, San Francisco, Cal., a late model Motiograph for advertising purposes; Christ Church, Alameda, Cal., a late model Motiograph for entertainment and educational purposes, and Pilgrim Church, East Oakland, Cal., a late model Motiograph.

These sales were made through their western representative, E. H. Kemp, 833 Market street, San Francisco, Cal.

Eastman Opens Branch in Los Angeles

THE Eastman Kodak Company has placed a representative, Perry E. Conner, representing the motion picture film department, in Los Angeles, and he has established headquarters at 510 South Broadway. It is understood Mr. Conner will remain there permanently to look after the wants of the many manufacturers, thus assuring more prompt and better service.

New Typewriter Slide on Market

THE Novelty Slide Company has just put out a new typewriter slide. Through this method exhibitors can make their own slides form type at very short notice.

Exhibitors who wish to add another feature to their program could by this means show news bulletins at any time during the performance.

New Motiograph Installations

M. H. LIVINGSTON, of The Peoria Film Exchange, Peoria, Ill., has ordered late models of the motor-driven Motiograph machines to be shipped as follows:

Jesse Chance, Lyric theatre, Farmington, Ill.; Majestic Theatre, Lincoln, Ill.; R. W. Berry, Tremont, Ill., and L. C. Higbee, Wyoming, Ill.

LANG'S FILM REELS
THE BEST MADE
14 in. \$1.50 12 in. \$1.25 10 in. \$1.00
CATALOGUE
LANG MFG. WORKS, Olean, N. Y.

Your negative developed, printed and titled complete
5c delivered **12** hours
per foot within
Titles **6c** per foot
GUNBY BROS., Inc.
145 West 45th Street New York City

SAVE TIME—SOLUTION
Use Corcoran Tank System
Get Price List No. 6
A. J. CORCORAN, Inc.
9½ John Street New York

ROLL TICKETS Specially Printed and Absolutely Guaranteed
Cash with order. No C.O.D. at these prices.
50,000 for \$5.40 200,000 for \$15.30
30,000 for 4.50 100,000 for 9.00
Write for Samples and Prices on Other Quantities.
Rees Ticket Co., 400 So. 10th St., Omaha, Neb.

FURNITURE & FURNISHINGS
On RENTAL
We equip your settings complete in accordance with your scenario.
WILLIAM BIRNS
103-105 West 37th St.
Phone: Greeley 6255.

SLIDES
OF ALL DESCRIPTIONS
Excelsior Illustrating Co.
219 6th Avenue, New York City
Tel. 7760-7761 Chelsea

PLAYER SLIDES
Just what you need, the best made, \$1.75 per dozen. Say Who. There is only one place to get them and that's from the NIAGARA SLIDE CO., Lockport, N. Y.

There Are Several interesting business boosting schemes outlined in the "Live Wire Exhibitors'" department of this issue. It will pay you to read every one of them.

Our Factory Is Yours!
Negative assemblers, projecting machines and an equipment second to none, with an organization of experienced people always at your SERVICE for DEVELOPING and PRINTING.
EVANS FILM MFG. CO.
Incorporated
416-22 WEST 216th STREET
Tel. 7652 Audubon at Broadway, New York

FREE SEATING PLAN
If you will send in your measurements.
OPERA CHAIRS
Steel and cast iron, maple folding chairs. Immediate shipment in many styles. Mention this paper and you can secure a special rate.
ATLAS SEATING CO.
501 Fifth Avenue, New York
Second-hand chairs if you want them.

PERFECT DEVELOPING AND PRINTING
For Amateurs and Professionals in any Quantities.
WE GUARANTEE QUALITY PLUS PROMPT DELIVERY AND PERSONAL SERVICE.
Prices, References and Factory Description Sent at Your Request
INDUSTRIAL MOVING PICTURE COMPANY
223-233 West Erie Street, Chicago

Get Poster Portraits of All The Universal Stars

A word about the pulling power of Portrait Posters when artistically displayed in your Theatre Lobby

UNCONSCIOUSLY, Exhibitors have a most powerful weapon placed in their hands in the shape of Public Hero Worship, but many of the supposedly wise Exhibitors have failed to take advantage of this magnificent possibility. The Public have learned to idolize all the Universal Movie Stars. They want to see their favorites all the time. Why not commercialize this desire by showing in an artistic manner, the beautiful poster portraits of all the Universal Stars in your Lobby? We have beautiful paper in 6 colors of every Universal Star. When well grouped these posters make a rich display.

Write your Exchange and order these poster portraits of the entire Universal crowd. Have someone with an eye for Art, display these posters in your lobby (frame them for your walls, if possible) and note the stunning effect. If you can't get these poster portraits from your Exchange, write or wire the Morgan Lithograph Co., of Cleveland, Ohio, and they will ship them to you direct, **BUT FIRST WRITE YOUR EXCHANGE.** Do it today.

Another Universal Winner

Three Sheet Posters for Single Reels

From the East-West-North-South—from every point of the compass—letters pour in to The Universal Offices every day, complimenting us on the new and unique ideas always produced first for the advancement of Universal Moving Pictures.

The latest stunt is our production (at immense expense) of 3-sheet posters for single-reel pictures. This is a radical departure from the ordinary routine. One-sheet stands were considered a luxury for single reelers, but the Universal stops at nothing.

No idea, no matter how good it is, is good enough for Universal Exhibitors; therefore, without regard to cost, we now have ready 3-sheet posters for from 7 to 9 single-reel pictures every week, allowing you to play up your single reelers as strong as the multiple-reel pictures.

You can get these 3-sheet stands from your Exchange, or if your Exchange cannot supply you promptly write or wire the **Morgan Lithograph Company, at Cleveland, Ohio,** and they will supply you direct. Try this new Universal winner. 'Twill pay you big returns. Write today.

THE LAST EGYPTIAN



IN FIVE PARTS

Released Dec. 7th on the

ALLIANCE PROGRAMME

A weird and spectacular modern drama staged in Egypt and London on a colossal scale, presenting a story abounding in thrilling scenes and powerful dramatic situations.

A sensational photodrama combining the mysterious atmosphere of the Orient with the "punch" of American production and American actors.

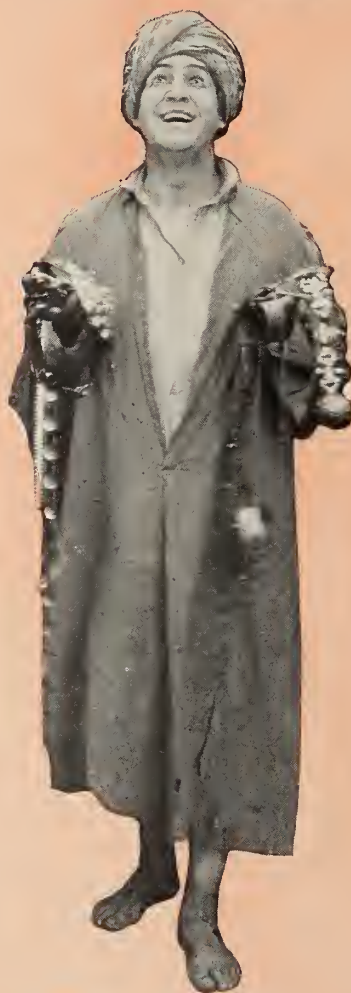

Terrific Battle to Death in the Secret Treasure Chamber Has Been Pronounced

The Greatest and Most Realistic Fight Ever Seen in a Motion Picture

Gorgeous Costumes and Magnificent Settings

The Famous Oz Cast of Beautiful Women

FARRELL MacDONALD
"The Last Egyptian"
with VIVIAN REED and the usual strong Oz cast.

THE OZ FILM MFG. CO.

SANTA MONICA BOULEVARD—GOWER to LODI STS.
LOS ANGELES - - CALIFORNIA



CHRISTMAS

Motion Picture News

HAS THE QUALITY CIRCULATION OF THE TRADE

PARAMOUNT PICTURES

JESSE L. LASKY

PRESENTS



H. B. WARNER IN **The GHOST BREAKER**

PLAYING HIS ORIGINAL ROLE IN
THE PICTORIZATION OF THIS THRILLING BROADWAY SUCCESS
BY PAUL DICKEY AND CHARLES W. GODDARD

RELEASED DECEMBER 7TH

JESSE L. LASKY FEATURE PLAY CO.

220 WEST 48TH STREET NEW YORK CITY

JESSE L. LASKY PRESIDENT	SAMUEL GOLDFISH TREAS. & GENL. MANAGER	CECIL B. DeMILLE DIRECTOR GENERAL
-----------------------------	---	--------------------------------------



ROBERT LEONARD AND ELLA HALL

III



THE MASTER KEY

by JOHN FLEMING WILSON

*A Thrilling Story of
Mystery and Romance!*

FIFTEEN MOVING WEEKS
UNIVERSAL
THIRTY PICTURES REELS

MOVING

UNIVERSAL



DANIEL FROHMAN

PRESENTS

WILLIAM FARNUM

IN A STUPENDOUS AND IMPRESSIVE FILM VERSION OF

WILSON BARRETT'S

SUBLIME AND IMMORTAL DRAMA

"The Sign of The Cross"

IN FIVE PARTS

RELEASED DECEMBER 21ST.



THE FOREMOST FILM CLASSIC EVER PRODUCED IN AMERICA.

Produced by the

FAMOUS PLAYERS FILM CO.

ADOLPH ZUKOR, President,

DANIEL FROHMAN, Managing Director EDWIN S. PORTER, Technical Director

Executive Offices,

213-229 W. 26TH. STREET, NEW YORK.



MONEY TO YOUR HOUSE



"Home, Sweet Home"

GRIFFITH'S HOME SWEET HOME

(Six Reels)
FOR THE HOLIDAYS
BOOK IT NOW

AN IDYL—A SERMON—AN ABSORBING DRAMA
is showing in more theatres to more money than any motion
picture ever produced.

THE MOUNTAIN RAT

(Four Reel)
A tense, vital drama of Western Life.—A house-filler.

GRIFFITH'S BATTLE OF SEXES

in five reels. The vital material would have made eight but
that isn't Griffith's way. Greatest story of the Double Moral
Standard ever produced or written. It jams theatres.

BOOK IT!

THE WRATH OF THE GODS

SIX SMASHING, THRILLING REELS OF CONCENTRATED
DRAMA PRODUCED BY
THOS. H. INCE

Japanese Story, Japanese Actors, Volcano in Eruption! Filling theatres. It fattens your box office—book it now.



All Mutual
Exchanges

CONTINENTAL FEATURE
29 UNION SQUARE,

CASH TO YOUR POCKET

BOOK

THE GREAT LEAP

MAE MARSH and ROBERT HARRON are the stars; four reels is the length and intense drama wonderfully well presented is the big claim to your attention. The finish is smashing drama. Book it now.

GANGSTERS

(Four Reels)

Long run at Weber's Theatre, New York. "A great lesson to all."—New York American.

Big Day Specials

RUY BLAS
THE FLOOR ABOVE
FROU FROU
JOSEPH IN THE
LAND OF EGYPT
PAPHO

CARDINAL RICH-
ELIEU'S WARD
DOPE
ZU ZU
MOTHS
LEGEND OF PROVENCE



Scene from "The Great Leap"

**FOR A WAR
FEATURE DAY
SHOW ONE
OF THESE BIG
SUCCESSES**

MEXICAN WAR PICTURES
By Special Contract with General Villa
THE DISHONORED MEDAL
With French troops in action
BATTLE OF GETTYSBURG
Greatest War Feature Ever Produced

FILM CORPORATION
NEW YORK CITY

*All Mutual
Exchanges*



STATE RIGHTS

MAKE ARRANGEMENTS TO BUY THESE GREAT STATE RIGHTS PICTURES NOW SO THAT YOU WILL BE IN A POSITION TO TAKE ADVANTAGE OF THE OPPORTUNITY THAT WILL PRESENT ITSELF AFTER THE HOLIDAYS—THE TIME WHEN THE PUBLIC WILL BE FREE TO PATRONIZE THE EXHIBITOR.

THE ESCAPE

THIS WONDERFUL SEVEN REEL PICTURE DEALING WITH A GREAT PROBLEM OF LIFE HAS SO MUCH PUNCH THAT IT WILL KEEP THE AUDIENCES TALKING FOR WEEKS AFTER THEY HAVE SEEN THE SHOW. REALISM IS PREDOMINANT AND THE THEME IS ACTUALLY TRUE TO LIFE. D. W. GRIFFITH CONSIDERS THIS ONE OF HIS MASTERPIECES.

THE AVENGING CONSCIENCE

EDGAR ALLEN POE, THE GREAT MYSTERY WRITER, THE FIRST OF HIS LINE TO WRITE A DETECTIVE STORY IS RESPONSIBLE FOR THE "AVENGING CONSCIENCE." HIS GREAT MASTERPIECE "THE TELLTALE HEART" HAS BEEN ADOPTED BY D. W. GRIFFITH AS A MASTER THEME FOR THIS GREAT SIX REELER.

WRITE WIRE, PHONE AT ONCE AS TERRITORY IS GOING FAST ON THESE GREAT SENSATIONAL FEATURES.

ALL POSSIBLE ADVERTISING ASSISTANCE HAS BEEN PREPARED FOR YOU WITH THIS GREAT LINE OF FEATURES AND YOU MUST ACT QUICKLY TO GET THE TERRITORY YOU DESIRE.

SEND AT ONCE FOR PARTICULARS TO

WESTERN IMPORT CO.
71 WEST 23rd STREET, N.Y.

SMASHING ALL OPPOSITION

for Week of **DEC. 13.**



KEYSTONE

ROSCOE ARBUTHNOT
 MABEL NORMAN
 MARY CHAPMAN
 MARY SWEET
 MARY CHAPMAN
 MARY SWEET

BRONCHO

The Panther
Wednesday Dec. 16

The Game of Life

Friday Dec 18

DOMINO

A Political Feud
Thursday Dec. 17

8"-10" Photos of our Players can be had by sending to Publicity Dept. 15 Cents for one-50 Cents for set of 4.

A WONDERFUL LOBBY DISPLAY

22"-28" Photo layouts in Character makeup of Trilby Normand, Chas Chaplin & Rescoe Arbuthnot

20 Cents each.

Released Exclusively through the Mutual Film Corporation

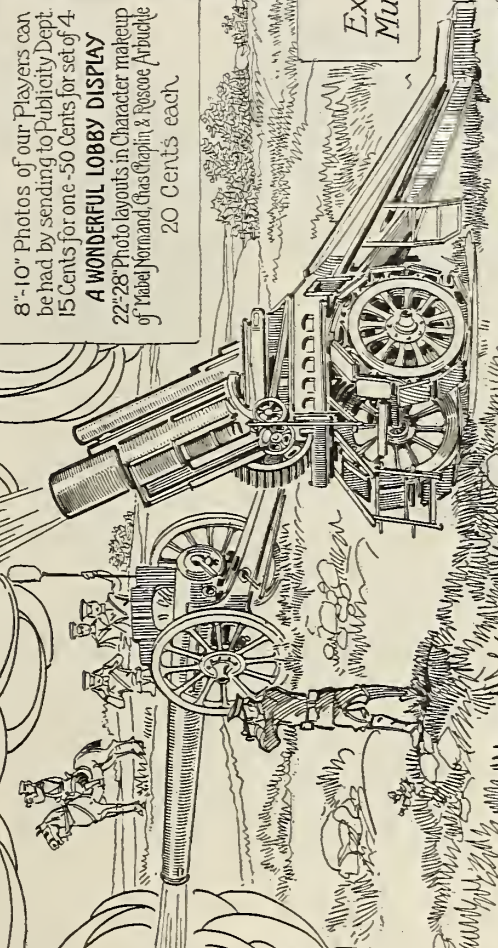

NEW YORK MOTION PICTURE CORPORATION

LONGACRE BUILDING 425 Str and BROADWAY NEW YORK





Frank Farrington

— the Thanhouser star

who was made famous in the character of Braine in *The Million Dollar Mystery*—now appears in regular releases of

Thanhouser Photoplays

This is simply another indication of the strength of the Thanhouser organization—a group of the most noted film stars known. Three Thanhouser productions are released each week through the Mutual Film Corporation in the United States and Canada. Book Thanhouser productions and draw *packed houses*.

For the current week we announce:

Sunday, Dec. 20th. "Sid Nee's Finish." A play depicting the life of the Chinese laundryman, Sid Nee. Enacted by a star cast including Sidney Bracy, Fan Burke, Joe Phillips.

Tuesday, December 22nd. "Under False Colors." This drama is the first Thanhouser release featuring Florence La Badie since *The Million Dollar Mystery* appeared. It is an exceptional two-reel play with Florence La Badie in the title role, assisted by Miss Forbes, Virginia Waite, Mrs. Farrington and Frank Wood.

Thanhouser Film Corporation
New Rochelle, N. Y.



See Americans First

Flying "A" and American "Beauty" Feature Films

MADE IN U.S.A.



"THE SOWER REAPS"

Thrilling Drama of Political Intrigue in Two Acts.
 Featuring Wm. Garwood and Vivian Rich. Direction of Thos. Ricketts.
 Release Monday, December 21st, 1914.

AMERICAN BEAUTY FILMS

"BRASS BUTTONS"

A Farce Featuring an Excellent Cast of Beauty Stars.
 Release Tuesday, December 22nd, 1914.

"TIN CAN SHACK"

A domestic drama replete with intense and throbbing situations.
 Featuring Ed Coxen and Winnifred Greenwood. Direction of Henry Otto.
 Release Wednesday, December 23rd, 1914.

Distributed exclusively through the United States and Canada
 by the Mutual Film Corporation.

AMERICAN FILM MFG. CO.
 CHICAGO

RUNAWAY JUNE

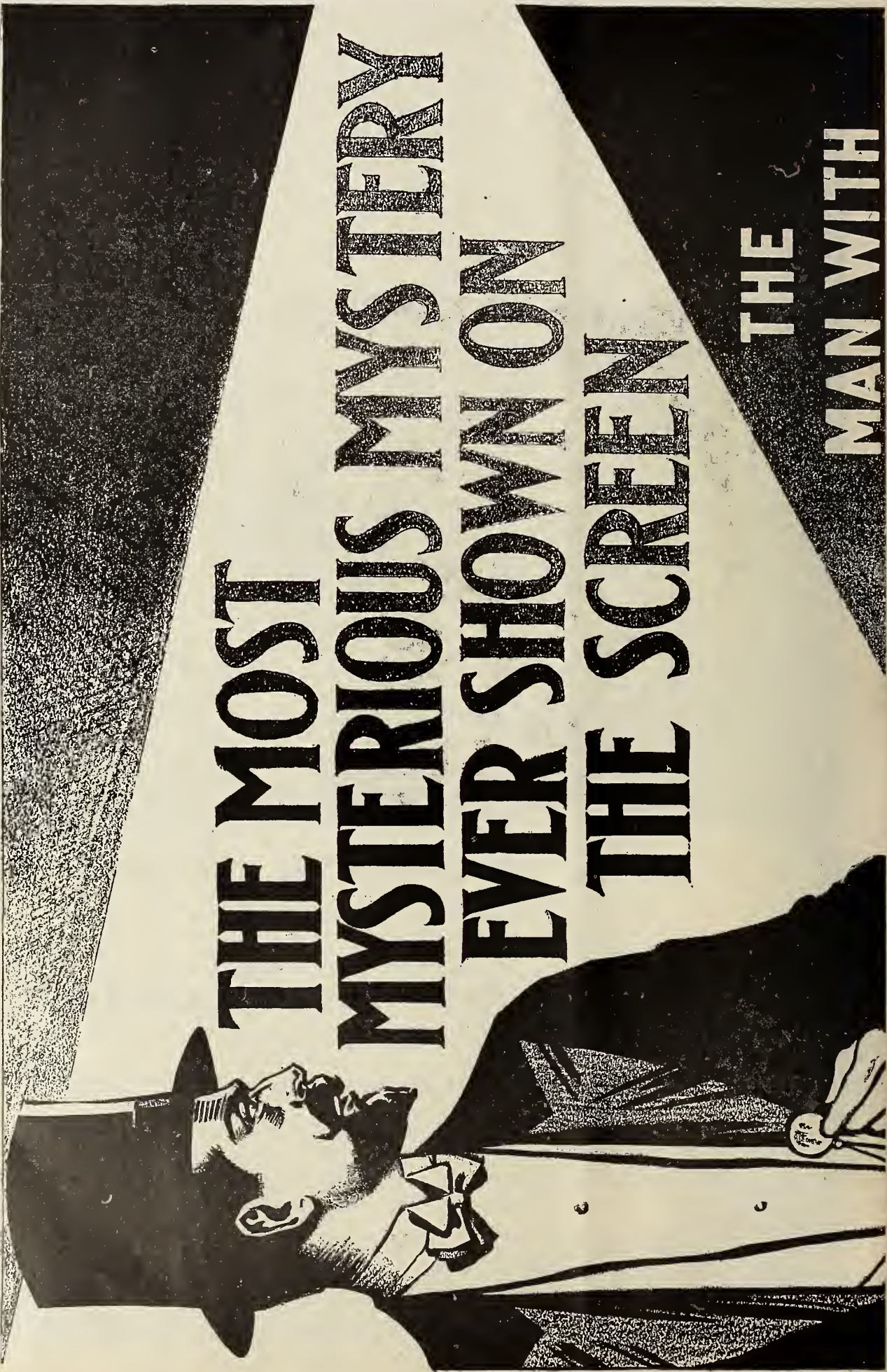

**THE MOST
MYSTERIOUS MYSTERY
EVER SHOWN ON
THE SCREEN**

**THE
MAN WITH**

THE BLACK VAN DYKE

HE SHADOWS RUNAWAY JUNE
WHEREVER SHE GOES - HE BREATHES
MYSTERY-EVERY MOVE HE MAKES IS CLOTHED
IN SHADOW - HE IS THE ENIGMA - TALL OF
STATURE - AS SILENT AS A SPHINX.

HE WILL BE THE TALK OF THE MOVING
PICTURE WORLD - 2500 NEWSPAPERS WILL
WRITE VOLUMES ABOUT HIM, AND THOUSANDS
OF YOUR PATRONS WILL WANT TO SEE
HIM ON THE SCREEN.

GO TO YOUR NEAREST MUTUAL EXCHANGE
NOW - SEE OUR REPRESENTATIVE - BOOK
"RUNAWAY JUNE" BEFORE IT IS TOO LATE.

IVAN FILM PRODUCTIONS, Inc.

— JUST RELEASED —

SHOULD A WOMAN DIVORCE?

(Five Reels)

A TIMELY MASTERPIECE OF GREAT MONEY MAKING POSSIBILITIES

A Photo-play based on the most perplexing problem of the day.

Magnetic story—full of pathos and human interest.

ALL STAR CAST—STUPENDOUS STAGING—MASTERFUL
PHOTOGRAPHY

SINS of the PARENTS

(Five Reels)

Featuring the world's renowned Tragedienne

Madam Sarah Adler

A Powerful
Realistic Drama
based on a
Big Theme

Full of
Gripping Situations
and
Dramatic Climaxes

THE FEATURE WHICH HAS PROVEN A
HOUSE JAMMER

LIFE in the HOLY LAND

(Six Reels)

160 Scenes—Biblical—Historic—Modern
showing the life, conditions and customs of the
inhabitants in Palestine

FASCINATING ENTHUSING
INSTRUCTIVE

Appeals to all creeds, races and religions

PACKS THE HOUSE
FILLS THE TILL

EXCHANGES

IVAN FILM PRODUCTIONS, INC., 32 Union Square, New York. Telephone, 1292 Stuyvesant.
For: GREATER NEW YORK, NEW YORK STATE and NORTHERN NEW JERSEY.

NORTHERN FEATURE FILM EXCHANGE,
610 Schiller Bldg., Chicago.
For: ILLINOIS and WISCONSIN.

McWILLIAMS AND HENRY, PEERLESS FEAT-
URE FILM EX., 824 Columbia Bldg, Cleveland.
For: OHIO.

MONARCH FEATURE FILM COMPANY, 12th and Wyandotte Streets, Kansas City.
For: MISSOURI, KANSAS, IOWA, MINNESOTA and NEBRASKA.

NAT A. MAGNER COMPANY, INC., Fourth Floor, Pacific Building, San Francisco.
For: CALIFORNIA, NEVADA and ARIZONA.

THE CONSOLIDATED FILM CO., LIMITED, 295 St. Catherine Street W., Montreal; 62 Richmond
Street E., Toronto; 212 Phoenix Block, Winnipeg; 411 I.e. Bldg., Vancouver, B. C.
For: CANADA.

State Rights Still Available for all of the above features. Apply

IVAN FILM PRODUCTIONS, Inc.

32 Union Square, New York

Ivan Abramson, Pres.

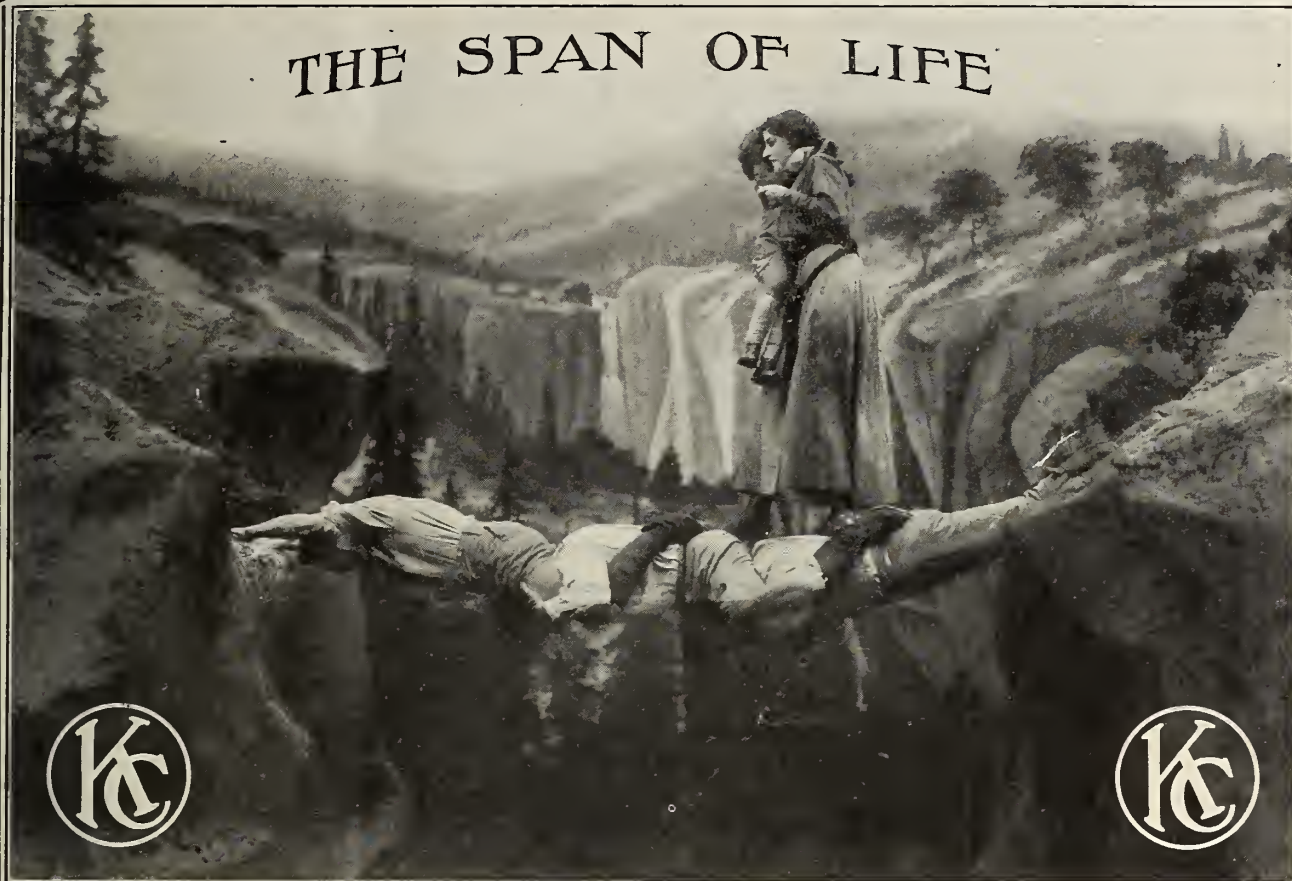

(5 Parts) **Sutton Vane's Great Melodrama** (5 Parts)

WITH

LIONEL BARRYMORE

A Kinetophote Production

That Tells It All

DON'T DELAY!

GET IT NOW!

Through These Exchanges

American Feature Film Co., 162 Tremont St., Boston, Mass.—
 Maine, New Hampshire, Vermont, Massachusetts, Rhode Island
 and Connecticut—All New England.
 Eastern Booking Offices, 1237 Vine St., Philadelphia, Pa.—Eastern
 Pennsylvania, Southern New Jersey, Virginia, Delaware and
 District of Columbia.
 Eastern Booking Offices (Pittsburgh Branch, 432 Wabash Bldg.)—
 Eastern Pennsylvania and West Virginia.
 Eastern Booking Offices (Cleveland Branch, 218 Columbia Bldg.)—
 State of Ohio.
 Dallas Film Co., Dallas, Texas—Texas, Louisiana, Oklahoma and
 Arkansas.

Midwest Feature Film Co., Loeb Arcade Bldg., Minneapolis, Minn.
 —North Dakota, South Dakota, Iowa, Minnesota, Wisconsin.
 K. C. Booking Co., Incorporated, Maller's Bldg., Chicago, Ill.—
 Illinois and Wisconsin.
 Pacific Coast Feature Service, 117-119 Golden Gate Ave., San
 Francisco, Cal. With Branches in Salt Lake City, Utah; Port-
 land, Oregon; Seattle, Washington; Denver, Colorado, and Los
 Angeles (403-404 Marsh Strong Bldg.)—Cal.—California, Oregon,
 Washington, New Mexico, Montana, Idaho, Wyoming, Colorado,
 Nevada, Arizona and Utah.
 K. C. Booking Co., Incorporated, 126-132 West 46th St., New York
 City—New York State and Northern New Jersey.

All Booking the Exclusive Programme of

Feature



Productions

TELEPHONE * 6072 BRYANT

NEW YORK CITY

126-132 WEST 46TH STREET



ALCO FILM

B·A·ROLFE

Presents

The Charming
Dramatic Star

Mabel Taliaferro

Rachael Crothers' Super
Cameo of the Stage



THE 7 OF 7 US

A 5 PART TALE
OF INFINITE
HEART INTEREST

RELEASE
DEC. 14

ALCO FILM

218 W. 42ND ST.

ALCO

CORPORATION

ALL STAR FEATURES POPULAR PLAYS & PLAYERS B.A.ROLFE PHOTO PLAYS
LIFE PHOTO FILM CORPORATION

OFFER
THE FORTHCOMING RELEASES ON THE ALCO PROGRAM

- DEC. 7 MADAME OLGA PETROVAIN. "THE TIGRESS"
- DEC. 14 MABEL TALIAFERROIN. "THE THREE OF US"
- DEC. 21 MARIE DRESSLERIN. "TILLIE'S PUNCTURED ROMANCE"
- DEC. 28 FLORENCE NASHIN. "SPRINGTIME"

THE FORTHCOMING RELEASES ARE BUT A CONTINUANCE OF
THE POLICY TO PRODUCE ONLY QUALITY

— . . . —
NOW PLAYING
AND PROCURABLE AT ALL ALCO EXCHANGES

- ETHEL BARRYMOREIN. "THE NIGHTINGALE"
- ANDREW MACKIN. "THE RAGGED EARL"
- JACOB P. ADLERIN. "MICHAEL STROGOFF"
- CHAS. A. STEVENSONIN. "SHORE ACRES"
- BEATRIZ MICHELENAIN. "SALOMY JANE"
- THOS. JEFFERSONIN. "RIP VAN WINKLE"
- ALL STAR CASTIN. "LITTLE LORD FAUNTLEROY"
- DIGBY BELLIN. "EDUCATION OF MR. PIPP"

IN TERRITORY HERETOFORE UNSOLD

- LINA CAVALIERIIN. "MANON LESCAUT"

CORPORATION NEW YORK CITY.

ALCO



WILLIAM FOX

Responsible for such money-getters as "Life's Shop Window" and "The Walls of Jericho" offers for booking through the Box Office Attraction Company the Charles Frohman New York Lyceum Theatre success

THE THIEF

In five parts—a production extraordinary from the William Fox Studios. A powerful and gripping domestic drama of unusual climacteric force—a production accredited by the critics to be the most notable film achievement of the season. (See the Morning Telegraph, December 7—the Moving Picture World and the Motion Picture News.)

DOROTHY DONNELLY

CREATOR OF MADAME X

In the star role with a supporting company of all-star players including Richard Buhler, Harry Spingler and others. Produced by Edger Lewis. Big assortment of advertising and publicity matter.

Arrange for Booking Before Your Competitor Does It

BOX OFFICE ATTRACTION COMPANY

WILLIAM FOX, President

Executive Offices: 130 West 46th Street, New York City

NEW YORK CITY, N. Y.—126 W. 46th St. Phone: Bryant 7340.
 WASHINGTON, D. C.—434 Ninth St., N. W. Phone: Main 1426.
 BOSTON, MASS.—10-12 Piedmont St. Phone: Oxford 6254.
 SYRACUSE, N. Y.—400 Eckel Theatre Bldg. Phone: Warren 119.
 PHILADELPHIA, PA.—1333 Vine St. Phone: Walnut 4503.
 PITTSBURGH, PA.—121 Fourth Ave. Phone: Court 1302.
 CLEVELAND, O.—618 Columbla Bldg. Phone: Cuyahoga Central 6260R.
 Bell: Main 5677.
 ST. LOUIS, MO.—3632 Olive St. Phone: Bell: Lindel 795; Kinloch: Delmar 7253.

KANSAS CITY, MO.—328 Main St. Phone: Bell: Main, 1008; Home: Main 7253.
 DALLAS, TEX.—1907 Commerce St. Phone: South Western: Main 2066.
 SAN FRANCISCO, CAL.—107 Golden Gate Ave. Phone: 4880 Market.
 DENVER, COLO.—Ideal Bldg., 17th and Champa Sts. Phone: Main 5071.
 MINNEAPOLIS, MINN.—Jewelers' Exchange Bldg. Phone: North Western
 Nicollect, 2498.
 SALT LAKE CITY, UTAH—McIntyre Bldg.
 CHICAGO, ILL.—314 Mallers Bldg., 5 S. Wabash Ave. Phone: Central 1716.
 SEATTLE, WASH.—1214 Thrd Ave. Phone: Elliott 1039.



Be sure to mention "MOTION PICTURE NEWS" when writing to advertisers.



He Coupled Up the Newspapers and the "Movies"

He placed the "Adventures of Kathlyn" in newspapers throughout the country. His latest great successes are "Lucille Love," "Trey O' Hearts," "The Master Key."

For two years he was syndicate manager of the Chicago Tribune and also its Sunday Editor. Then, he made newspaper stars of Lillian Russell and Laura Jean Libby; he syndicated the political writings of Finley Peter Dunne and Sam Blythe; he secured national audiences for Jim Corbett and "Mr. Dooley." To cut a very long list short, a great number of the important new features in American journalism have been nationalized by A. P. Robyn.

The newspapers know he has no use for dead ones. He has kept their respect for his endorsements by giving them service. He will handle nothing except that which is good; and his customers believe in his say-so.

If you have an important idea for a feature, confer with him.

The A. P. Robyn Newspaper Syndicate, American Trust Bldg., Chicago



THE DAWN of A NEW ERA

Better Pictures
Finer Theatres
Higher Admission Prices



Compliments of —
Paramount Pictures Corporation
To the Trade
Christmas-1914

V. Trotto

HER DUPLICATE HUSBAND



An unusual picture showing the remarkable situation brought about by the combination of a prison ship, an innocent convict and a skillful surgeon. Released in the daily United Service of single and multiple reels.

UNITED FILM SERVICE (WARNER'S FEATURES, INC.) N.Y.

A
\$4,000,000
CONTRACT

For the exclusive purpose of providing the single and double reel daily releases of the United Film Service, fourteen individual companies of the world's best producers were combined.

With this big, strong organization (the first of its kind ever formed) the

UNITED
FILM
SERVICE

at once executed a contract involving the payment of over \$4,000,000 for pictures.

These pictures---superb one and two reel comedies and dramas ---are being released daily to the thousands of discriminating exhibitors who have selected the United Film Service.

The making of the \$4,000,000 contract was the final step in the year's preparation for the establishment of the United Film Service on a solid, permanent foundation. Write your nearest United Exchange.

UNITED FILM SERVICE (Warner's Features, Inc.) **New York**

THE PRICE HE PAID

A vital, vigorous five part drama by

Ella Wheeler Wilcox



The most powerful photo play of the year. Intense in action absorbing in interest, irresistible in appeal. Now ready for booking. Write your nearest United Exchange

UNITED FILM SERVICE (WARNER'S FEATURES INC.) N.Y.

SPECIAL FEATURES

General Film Company

TITLE	MAKE	No. of Reels	TITLE	MAKE	No. of Reels
THIRD DEGREE	Lubin	5	IN TUNE WITH THE WILD.....	Selig	3
THOR, LORD OF JUNGLE.....	Selig	3	THE WOLF	Lubin	6
THE BATTLE OF SHILOH.....	Lubin	4	SHADOWS OF THE PAST.....	Vitagraph	3
THE LION AND THE MOUSE.....	Lubin	6	MR. BINGLES' MELODRAMA.....	Vitagraph	3
THROUGH FIRE TO FORTUNE.....	Lubin	5	MEN AND WOMEN.....	K. & E. Biograph	3
JUDITH OF BETHULIA.....	Biograph	4	THE SECRET OF THE RING.....	Kleine	3
GERMINAL	Pathe	5	MY FRIEND FROM INDIA.....	Edison	3
LOST IN MID OCEAN.....	Vitagraph	3	LIBERTY BELLES	K. & E. Biograph	3
A ROMANY SPY.....	Pathe	3	THE ERRING	Lubin	3
A CELEBRATED CASE.....	Kalem	4	AMBUSHED	Essanay	3
THE FULFILLMENT	Essanay	3	SONG OF THE SOUL.....	Kleine	3
NIGHT RIDERS OF PETERSHAM.....	Vitagraph	3	KIT, THE ARKANSAS TRAVELER.....	Kalem	3
HARDING'S HERITAGE	Pathe	3	CHIP OF THE FLYING "U".....	Selig	3
DAUGHTERS OF MEN.....	Lubin	5	FAIR REBEL	K. & E. Biograph	3
THE OTHER HALF OF THE NOTE.....	Kalem	3	HOUSE NEXT DOOR.....	Lubin	5
HER LADYSHIP	Selig	3	MY OFFICIAL WIFE.....	Vitagraph	5
GOODNESS GRACIOUS	Vitagraph	3	UNCLE BILL	Vitagraph	3
OFFICER JIM	Lubin	3	THE FORTUNE HUNTER.....	Lubin	6
DEATH SIGN AT HIGH NOON.....	Kalem	3	THE VENDETTA.....	Kleine	5
GAME OF LIFE.....	Selig	3	BAREFOOT BOY	Kalem	3
THE MILITANT SUFFRAGETTE.....	Pathe	5	THE WIFE	K. & E. Biograph	3
FRANCIS MARION, "THE SWAMP FOX".....	Kalem	3	KING OF CHANCE.....	Kalem	3
A MILLION BID.....	Vitagraph	5	THE WAGES OF SIN.....	K. & E. Biograph	3
THE FATAL WEDDING.....	K. & E. Biograph	3	THE PLUM TREE.....	Essanay	3
THE GAMBLERS	Lubin	5	THE FIFTH MAN.....	Selig	3
ANNE BOLEYN	Kleine	3	THE GOLDEN BEETLE.....	Kleine	4
STRUGGLE FOR LIFE.....	Pathe	5	THE WEIGHT OF A CROWN.....	Lubin	3
MONGREL AND MASTER.....	Essanay	3	MARAH, THE PYTHONESS.....	Lubin	3
THE ROYAL BOX.....	Selig	4	CHARITY BALL	K. & E. Biograph	3
THE CURSE OF CREED.....	Melies	5	HEARTS AND MASKS.....	Selig	3
FACING THE FOOTLIGHTS.....	Pathe	3	A FLORIDA ENCHANTMENT.....	Vitagraph	5
BLOOD WILL TELL.....	Essanay	3	ROAD TO YESTERDAY.....	K. & E. Biograph	3
CONQUEST OF QUEBEC.....	Kalem	5	THE PAINTED WORLD.....	Vitagraph	3
THE LILLY OF THE VALLEY.....	Selig	3	JUDGE NOT	Kleine	4
CLASSMATES	K. & E. Biograph	4	GARRISON'S FINISH	Selig	3
MAN OF THE HOUR.....	Selig	3	POWER OF THE PRESS.....	K. & E. Biograph	4
MR. BARNES OF NEW YORK.....	Vitagraph	6	IN THE GLARE OF LIGHTS.....	Essanay	3
LOVE, LUCK AND GASOLINE.....	Vitagraph	3	THE RED CROSS NURSE.....	Melies	3
THE BILLIONAIRE	K. & E. Biograph	3	THE THREADS OF DESTINY.....	Lubin	5
SPORT AND TRAVEL IN CENTRAL AFRICA	Pathe	5	WHEN THE LIONS ESCAPE.....	Melies	3
THE GOOD FOR NOTHING.....	Essanay	4	THE GENIUS	K. & E. Biograph	3
THE BOER WAR.....	Kalem	5	STONEWALL JACKSON'S WAX.....	Lubin	3
THE THUMB PRINT.....	Melies	4	THE INVISIBLE POWER	Kalem	4
STRONGHEART	K. & E. Biograph	3	THE WOMAN IN BLACK.....	K. & E. Biograph	4
LORD CHUMBLEY	K. & E. Biograph	4	UNDER THE GASLIGHT.....	K. & E. Biograph	4
SEVEN DAYS	K. & E. Biograph	3	"413"	Vitagraph	3
TREASURE OF ABDAR RAHMAN.....	Pathe	4	THE WIN(K)SOME WIDOW.....	Vitagraph	4
'NEATH THE LION'S PAW.....	Melies	3	THE STORY OF THE BLOOD RED ROSE.....	Selig	3
ONE WONDERFUL NIGHT.....	Essanay	4	THE TELL TALE HAND.....	Essanay	3
WOMAN AGAINST WOMAN.....	K. & E. Biograph	3	A POOR RELATION.....	K. & E. Biograph	3
IN DEFIANCE OF LAW.....	Selig	3	THE LOCKED DOOR	Vitagraph	3
A KINGDOM AT STAKE.....	Kleine	3	THE TANGLE	Vitagraph	4
CAPTAIN ALVAREZ	Vitagraph	6	THE SPY'S FATE	Lubin	3
OTHELLO	Kleine	5	IN THE DAYS OF THE THUNDERING HERD	Selig	5
SEANNON OF SIXTH.....	Kalem	5	THE STRANGE STORY OF SYLVIA GRAY.....	Vitagraph	4
MAN'S ENEMY	K. & E. Biograph	3	THE BATTLE OF LOVE.....	Essanay	3
			FANTASMA	Edison	5
			THE SCHOOL FOR SCANDAL	Kalem	4



**WORLD'S LARGEST
SAWYER
FILM MART
1600 BROADWAY-NEW YORK**

**Merry
Christmas!**

Good Pictures mean more to Film Men than Christmas Presents. Sawyer is ready to give you good pictures every day of the year. Get wise!

SAWYER SERVICE Is getting to mean more every day
Pictures like these tell why!

Our next release—sensational 5-Reel “Aquila” Production—every player a famous star

“AS A MAN SOWS”

Thrilling Tale of a Master Criminal and Modern Society Life

“THAIS”

With the Popular Stars
Constance Crowley and
Arthur Maude

The Daring Story of a
Passionate Love that has
thrilled millions. 4 Reels.

First of Prize Winning
Comedy Series

“WITHOUT HOPE”

A FOUR REEL
FLAMINGO FILM

Release Date, Dec. 20

**THE LADY
OF LYONS**

All Star Cast in gorgeous
4-Reel picturization of
Lord Bulwer Lytton's
world famous love story.

CECIL SPOONER

In Her Own 4 Reel
Drama of Circus and Society

“Nell of the Circus”

EDYTH TOTTEN

In Her Famous Dramatic Success
—500 Thrills in 5 Reels

“A Factory Magdalen”

MONTREAL—Allied Features, New Berks Bldg.
INDIANAPOLIS—Union Film Co., 705 State Bank Bldg.
ATLANTA—“Southern Sawyer,” Forsyth Bldg.

ALBANY—Terwilliger & Shackett, 29 N. Pearl St.
BOSTON—Phoenix F. Co., 129 Columbus Ave.
BUFFALO—Terwilliger & Shackett.
CHICAGO—Union Film Co., 164 W. Washington St.

LOS ANGELES—Nat A. Magner, Inc.
MINNEAPOLIS—Sherman F. F. Co., Temple Court Bldg.
NASHVILLE—Anderson F. Exch., 1st Nat. Bank Bldg.
NEW YORK—Colossus F. Co., 110 W. 40th St.

DALLAS—Dallas Film Co., Andrews Bldg.
DENVER—“Sawyer.”
DETROIT—Casino F. Co., Dime Bank Bldg.; Progressive Film & Equ. Co., 97 Woodward Ave.
KANSAS CITY—Interstate Film Co., Gloyd Bldg.
OMAHA—“Sawyer,” 1404 Douglas St.

PITTSBURG—“Sawyer.”
PHILADELPHIA—Interstate F. Co., 1304 Vine St.; Fairmont F. F. Co., Ninth St.
SAN FRANCISCO—Nat A. Magner, Inc.
ST. LOUIS—“Sawyer.”
SEATTLE—“Sawyer.”
SALT LAKE CITY—“Sawyer.”
WINNIPEG—“Allied Features.”

"ZUDORA" STOPS TRAFFIC ON SOUTH JACKSON STREET MORE THAN THREE HOURS



**Read
This!**

The Monroe theater appeared to be the mecca of all the people in town last evening, the sidewalk in front of the show being completely filled with men, women and children from shortly after seven until long after ten o'clock. At one time the press was so great that Chief of Police Blunt had to interfere. The tremendous crowd, the largest in the history of the show house, was occasioned by the showing of "Zudora," the Thanouser series picture so extensively advertised in the Chicago Tribune. The management states that over 1,600 people saw the picture, and undoubtedly many hundreds more were unable to get in at all. As it was, the show ran until almost midnight.

ZUDORA

Thanouser's Greatest Photoplay

Do You Want Crowds Like This?



Trade Mark Registered.

For booking arrangements of this crowd-getting motion picture serial, apply *at once* to Thanouser Syndicate Corporation's representative at any Mutual Exchange in the United States or Canada.

Thanouser Syndicate Corporation
71 W. 23rd St., New York City, N. Y.

Produced by the Thanouser Film Corporation, New Rochelle, N. Y.
Producers of The Million Dollar Mystery



Trade Mark Registered

"When You See It
In 'The News'
It's NEWS"

Motion Picture News

HAS THE QUALITY CIRCULATION OF THE TRADE

"The Exhibitors"
Medium of
Communication"

TEL. 7650 BRYANT

TWO HUNDRED AND TWENTY WEST FORTY-SECOND STREET

NEW YORK CITY

Volume X

DECEMBER 19, 1914

Number 24

1915, As Seen From 1914

AND yet again this has been the greatest year in motion pictures.

A year ago, or, rather, in the early spring of last year, I put this question to an experienced observer of conditions:

"Don't you think that the industry has now over-reached itself—that it is in a boom condition, up to and beyond its normal crest of development?"

◆◆ ◆◆

"**W**ELL, I might," said he, "except for the fact I have laid this charge against the industry every year for the past seven years and each time found myself in error.

"Every year I have said to myself: Here, surely, is the apex of development! Now, look out for subsidence. But the industry did not subside. On the contrary, new and greater heights of development were attained. We swerve off at some great angle or angles and, all in all, we keep on growing despite weaknesses and in an amazing way. There seem to be no end and no limitations."

All of which is very true. But, for analysis, I should change the last sentence and say:

"There seems to be no end because there are no limitations."

◆◆ ◆◆

LAST Christmas, on this page, some prophecies were attempted and some truths asserted. Like most prophecies, many did not come true, within the year; and the assertions all may not have been truths.

But one at least was; and today it is more deeply significant than ever. As a reason, it is at the bottom of this year's, last year's and each year's amazing development of this industry.

It will be the fundamental reason for the surprising growth to come.

It is the elasticity of the motion picture.

◆◆ ◆◆

THE motion picture is the expression of life itself.

As such, its field of supply, its sources for expression, are only limited by the world and the history of the world. Its appeal is only limited by those of the human race who do not see, or seeing, cannot comprehend.

◆◆ ◆◆

AT first the picture was only a novelty.

Its appeal was confined to novelty-seekers.

But those who judged that it would remain a novelty were no more hopelessly wrong than are those today who still believe it to be a mediocre form of amusement, whose chief attraction consists of showing things in motion.

This year we have proven that the motion picture is dramatic.

People sneered at this possibility only a year ago. But dramatic success has been accomplished.

Mistakes had been made. Great stars have been miscast, and good looks and plays were spoiled in their adaptation to pictures.

The exasperated public and exhibitor have cried out:

"Cease, gentlemen, and give us just good pictures. We don't want big names for drawing-cards: give us good pictures."

◆◆ ◆◆

BUT here and there real successes have been evolved; and the achievement is great; it is wonderful.

We know now that we can and will make

good pictures of good books and plays—and this on a general scale.

We even know—because it has been fully proven—that the picturization of a play can be made more attractive than the play itself, better in atmosphere, story, construction, artistic presentation, and, at least, as good in acting.

And from this we know that books and plays can now be successfully picturized—many, indeed, improved upon—and through this agency made imperishable and accessible to the inhabitants of the civilized world.

Indeed a wonderful—and a new—achievement!

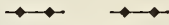

A GAIN, this year we have increasingly proven the motion picture to be a big, vital adjunct to daily journalism.

The still photographs of the daily newspaper are in motion now, not only in the big centers of population, but wherever the newspaper goes.

A great field, just started!

We have proven the motion picture to be serial fiction, and this with a most varied subject matter and through very wide channels of distribution.

All this progress within a year! All of it along new lines! And yet a few years ago it seemed as though the picture had reached its commercial limit of development.

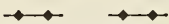

THE reason is the picture's elasticity—the fact that so many new lines of development are constantly available and that as each comes into being, a new class of patrons, perhaps millions, are brought regularly to the theatre door.

Thus the potential market is so great, its absorption of what it wants so ready, that the industry races along, surprisingly, overpoweringly, despite over production and poor production along certain lines, despite much faulty exhibition, and a measure of uneconomic distribution.

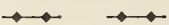

IT is a fact, which often we fail to reckon on, that several millions more of people see motion pictures this year than last year.

They are not "fans." They are not tickled with mere novelty or photographic motion.

They go to see the kind of pictures that were not generally produced last year—excellent dramatic, topical and educational pictures—pictures which were deemed impossible but three

years ago, and which were called masterpieces but a year and a half ago.



FOR the comfortable housing of this newer and greater audience there have sprung up all over the country—from Broadway to Vancouver—large and beautiful edifices, devoted wholly to motion pictures.

Never in the entire history of the amusement business has there been a building era so remarkable in every way.

The better picture, the better class of patrons, the better theatre—these are the developments of the year past, in so remarkable a degree that 1914 will remain a red letter year in the history of the industry.

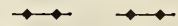

JUST what new lines of the ever-elastic picture will develop in 1915—in its production, distribution and exhibition—we do not clearly know: but we do know that new lines will develop and that a much greater market will again spring into being.

There is the unbroken ground of the educational field—the one we talk so much about and do so little for—the utilization of several hundred thousand schools, churches and colleges, for motion pictures.

Here is a field, undeveloped simply because no force sufficiently resourced and organized has been applied to it.

It is the writer's opinion that the most signal advance in 1915 will be another enterprise, also much discussed but thus far incompletely undertaken—namely, the national advertising of pictures.

Here again is an undertaking which demands adequate resources and organization: but these are not lacking within the industry today.

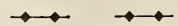

AS an element in 1914's progress, however modest, I wish in closing to speak a word for the MOTION PICTURE NEWS.

The things we stand for have been made patent in these columns. They need not be enumerated.

Suffice to say they spell progress within and for the whole industry, in which we consider the exhibitor to be the fundamental factor. We, too, have progressed in 1914—that is as patent as our policy. Perhaps the best indication of our progress is this number, which with some pride, we place before the trade.

WILLIAM A. JOHNSTON.

CHRISTMAS SEASON FINDS HEADS OF PROGRAMS OPTIMISTIC OVER FUTURE OF FILM INDUSTRY

A Banner Year in Sight, Says President Aitken of the Mutual



Harry E. Aitken, president of the Mutual Film Corporation, in response to a request for a seasonable expression to MOTION PICTURE NEWS, said:

"The responsible, enterprising factors in motion pictures are confronted by a season of opportunity and profit which I believe will be the greatest in the history of this tremendous industry.

"Business methods are being applied to business conditions, and the art of pictures has been developed to a point almost undreamed of by those who began with motion pictures in their earlier stages of development.

"There are bound to be disappointments for those who have entered a technical field without first having mastered its requirements, but the experienced organizations will not be among those to share in these.

"In this connection it may be the proper time to sound a note of warning to those of the public who regard the motion picture business as presenting the same sort of possibilities offered by the gold mining and oil opportunities of a few decades ago. Those who seek the profits of the motion picture industry should remember the large amount of capital essential to successful operation under present conditions, and they should exercise care in choosing only those of ripened and successful experience in the industry to handle their investments.

"I have had occasion before to call attention to the fact that isolated concerns cannot hope to compete with the large companies in presenting features, because the larger companies can present them as by-products and at a price which the smaller companies cannot hope to meet.

"I merely make mention of these circumstances to discourage reckless investment in an important business, which has a technique which must be learned and which requires tremendous capital to operate.

"Motion pictures are better today than ever before—millions are interested in their presentation.

"Astounding Development"—Hodkinson of Paramount Pictures



W. W. Hodkinson, president of Paramount Pictures Corporation declares:

"It is indeed interesting to trace the development of the film business as step by step it has progressed from the stage of being a toy or scientific novelty to where it ranks fourth in the industries of the United States where it has superseded largely the entire field of theatrical activities, and to where it rivals the printing press itself in shaping opinion

and providing education and pleasure for the public.

"The motion picture industry has been the wonder of the financial world, because it has been able to reach its present stage of development without enlisting outside capital, as has been customary with all other new enterprises of similar magnitude.

"The limited capital of individuals combined with their energy has been ample to develop the business to its present stage. In the future, however, the motion picture industry must be conducted along conservative business lines rather than in the haphazard manner that has prevailed. A few of the thinkers have long realized that this was necessary.

"The Paramount Pictures Corporation was the first recognition in a large way of the necessity of proceeding according to definite business principles in the distribution of films.

"The efficient distribution of the superior product is the problem of the future, and Paramount is devoting and will continue to devote every energy along this line."

Powers, of Unitea Film Service, Sees Big Business Ahead for Producers



"It is wrongly argued that periods of general depression bring stringency or disaster to enterprises that have for their prime object the mission of relieving the mind of its unpleasant burdens," says P. A. Powers, president, United Film Service.

"In other words, the 'business' of entertaining should, by a rule of inverse reasoning, which, nevertheless, is correct reasoning in this instance, be in its most flourishing condition when other lines of endeavor are adversely affected. Therefore, it is apparent that the moving picture industry is not subservient to the general panicky feeling that now exists in the markets of the world on account of the war.

"Instances which seem to prove that my above deductions are incorrect cannot be traced to general conditions. Rather are they the manifestation of organic weakness as regards individual enterprises in this field. Where sound principles of business are applied and where methods dictated by experience are in vogue, a corporation embarked in the manufacture or marketing of photoplays cannot fail of success.

"I figure that the coming year will be a period of solidification in the motion picture business. I feel that much knowledge will be derived during that period which will tend toward the systematization of the business. I also believe that a genuine literature of the screen is being gradually developed, and that the grade of offerings during the season now approaching will be of a much higher grade than has generally been the case.

"I see in the present lack of stability in financial circles nothing more than a natural readjustment which, logically, will result in a firmer foundation on which to base future administration of business affairs."

The day has really gone by when a slight fluctuation in general business conditions brings about depression in the film industry. The public insists upon being amused come what may.

Seely of Alco is Pleased With Bright Outlook for the Coming Year



With calamity howlers on every side, the average producer and distributor proclaiming the ruination of the business, upheaval of present-day methods, the losing game of the exhibitor and the impossibility of securing consistently good material, President Seely, of Alco, "sits tight" and speaks in glowing terms of the outlook.

"There is not a day passes," says Mr. Seely, "during which a new batch of

contracts does not arrive.

"Our temporary clients are fast becoming permanent, and the Alco program slides majestically to the heights we originally aspired to.

"Within the past two weeks, nineteen new houses have contracted for Alco service. The managers of these houses are tried and true picture men and are not experimenting.

"The veriest tyro of an exhibitor realizes the advantage of a feature program over an ordinary run of pictures and are, according to our results, acting accordingly.

"Our exchanges report improvement in the financial condition of their various territory. Our peculiarly constructed contract, which eliminates all hardships, insofar as the exhibitor is concerned, has struck a most popular chord and we are reaping the reward.

"Our original idea of allowing the exhibitor to try our program, then, if he found it a burden, to discontinue it, proved salt on the festive table. It is the seasoning with which the exhibitor can temper his futures."

Cobe a Firm Believer in the Feature



Andrew J. Cobe, the director of the destinies of the Alliance Film Corporation, while admitting that the single reel has a place to fill, believes that the great possibilities of the motion picture art will and can only be realized by the film that is in multiple reels.

"The feature is here," says Mr. Cobe, "but if it is to stay and be a source of entertainment and inspiration to the spectator and a source of profit and prestige to the producer, it will have to be more than the average feature is today.

"The ideal feature is a mixture of art, sentiment, action, suspense, good acting and intelligence. I believe that this type of film is on the way, and when it arrives the public will welcome it. There are pictures that are made intelligently but lack sentiment, and pictures with sentiment that are ridiculous because the intelligence is missing.

"It was this faith in the public and faith in the real feature that prompted me to launch the Alliance program into the already crowded waters of the film industry. The success that has attended the venture has substantiated the faith. The features on my program all conform in a more or less degree to my ideas and ideals."

Clements Enthusiastic Over 1915 Prospects



B. E. Clements, Kriterion Service Mica Film Corporation, says:

"You can put me down on record as having said that I predict that the year 1915 will be a banner year in the moving picture business. I have heard people say, and I know myself, that business in general throughout the United States in the past year has been nothing to brag about.

"This has been due to several things, including the tariff revision, unsettled conditions in financial circles, the turmoil in Europe and the tendency of big busi-

ness to sit tight. This, however, has not been the case with the moving picture business, as this year has surpassed all previous years in prosperity.

"I believe these very things that have effected the business world adversely in the past year are permanently and effectually straightening out, and there should be no reason why business in general should not experience a most successful year in 1915.

"This, of course, will have its effect in the film business and give it increased prosperity. You ask me regarding the Kriterion Program? I will sum it up in a few words: Good stories, good photography, and co-operation with the exhibitor. And these, I know, are absolutely essential. The people demand quality, for they are educated in this line, and we manufacturers must give it to them.

"Allow me to join the others in wishing everyone a very Merry Christmas and a most prosperous New Year.

NEW YORK ASSOCIATION HOLDS MASS MEETING

A MASS MEETING of the Motion Picture Exhibitors' Association of Greater New York was held at the Marlborough Hotel on Wednesday morning, December 2.

Matters relative to legislation for the coming year was taken under consideration and a legislation committee was appointed with Mr. Rosenson as its chairman for the purpose of drafting a bill for the admission of minors in motion picture theatres and also a bill permitting standees, which the exhibitors will endeavor to have passed during this legislative term.

The matter of the ball was taken up and much enthusiasm was shown by the exhibitors for the hearty co-operation which the manufacturers and tradesmen have extended to them.

After matters relative to the ball have been straightened out the entire Association will be reorganized in accordance with the new constitution and by-laws and its principles will be strictly adhered to.

Selznick Predicts Disappearance of Daily Changes of Programs Everywhere



Lewis J. Selznick, vice-president and general manager of the World Film Corporation, is very enthusiastic over the prospect for good business in the film field.

Mr. Selznick declares that the demand for features is larger than ever. The public has taken to the idea of multiple reels for the development of a story that the popularity of these pictures is increasing with leaps and bounds.

At the same time Mr. Selznick has observed that the people attending motion picture theatres are impatient with padded feature pictures. He says that the days of mere yardage and footage is over. A feature in order to take well must be a real feature—every foot of film must help tell the story of the plot effectively.

Mr. Selznick also declares that the day of the daily change of program is going by. A producer cannot do any picture justice if it must be turned out in a hurry to meet the demands of the daily change plan. Time, thought and money must be spent on any production to make it acceptable, according to the high standards now set for motion pictures by the public.

He expects to see the day not far distant when there will not be any daily changes. All theatres will have a few good pictures showing at least several days, and probably a week.

ITALY A MARKET FOR AMERICAN FILMS

THE war has not only opened the South American film market to producers in the United States, but has made Italy a possible user of American made pictures. This is the result of the sudden curtailment of production among English, German and French studios.

Italy has been a generous buyer of films manufactured in these countries, but in the present crisis is forced to turn elsewhere for pictures. America thus benefits by the situation.

Our producers in supplying the present need of Italy may open up a permanent market for American photoplays of the highest class.

Letters from abroad recently received by MOTION PICTURE NEWS indicate an opportunity in Italy for films made in this country. One in particular from Aldo P. Zucchi, Milano, 23 Viale Bianca-Maria, follows:

"I am a large user of films and wish to communicate with a few important American firms. Formerly I obtained a large proportion of my reels from Germany, England and France, but on account of the war, the supply is now practically cut off.

"I might mention incidentally that there is an excellent opportunity for American manufacturers of high class pictures and accessories in my country. They would find this market a very profitable one. It will certainly pay such firms to investigate the situation here."

FIREPROOF FILM BUILDING FOR MINNEAPOLIS EXCHANGE MEN IS CONTEMPLATED

Special to MOTION PICTURE NEWS

Minneapolis, Dec. 8.

A MODERN fireproof building built especially to meet the needs of film companies and which will house practically all the agencies in Minneapolis is now practically assured. The plans call for a five or six-story building with foundation for other stories to be erected in the heart of the business center of the city.

A Minneapolis business man who so far has requested that his name be not given out has met the distributors and asked them to agree to take leases in the proposed structure. Many have already agreed to and the promoter believes all of them will sign.

The plans are for a building that will rank with any in the world built for the motion picture business. There will be an exhibition hall, club and reception rooms, facilities for entertaining the visiting patrons and an abundance of room and light for all kinds of work.

THE NEED OF STRONG CO-OPERATION

BY MARION S. PEARCE,
President, Motion Picture Exhibitors' League of America.

National Executive Board Desires to Conduct Affairs of the Organization with the Idea of Laying a Good Foundation for Making the Association a Gibraltar of Strength, and, While Recognizing Excellent Work Already Done by Earnest Members, Issues Call for More Concerted Effort

WITH the last half of the year 1914 gone, the outlook for the League is very encouraging. The exhibitors all over the country are awakening to the absolute need of a strong state and national organization, realizing that it is through this, and this alone, that they may enjoy every advantage that is their right.

And that when it comes to the regulation of legislation that concerns and affects the motion picture interests, the law-makers, politicians and censor-cranks will find we have something to say that commands attention and gets results.

I am sure you realize that the exhibitors' league is being run by exhibitors who have the welfare of every exhibitor in the United States and Canada at heart, who are doing that which will accomplish for them the greatest good, as it is the earnest desire of the National executive board to conduct the affairs of the league in such a way that a good foundation will be laid for the building of one of the strongest organizations possible—an organization that will be a pride for every member to be a part of.

Yet it is true, that a comparatively few exhibitors are carrying the burden for the advantage and benefit of the many.

It's a good deal like an incident I once heard of, when a ship's crew were making their way from an abandoned ship to the nearest land in a rowboat. Every man served his allotted time at the oars, pulling for all he was worth to gain the mainland, with the exception of one. And this fellow, for one reason or another, wouldn't get in and do his share. He wanted his life saved as much as anyone, but depended on the efforts of his fellows. That man was a "boarder."

Exhibitors' Shoulders to the Wheel

Throughout the country, I'm mighty glad to say that a great many exhibitors have their shoulders to the wheel—doing things—working hard—showing results. But there are some "boarders" in the boat. And there are a number of exhibitors who are not putting out this sort of effort, with the result that the league is denied the efficiency it might so fully and so easily enjoy, if every man would only do his fair share.

Cooperation—that's the one thing that is nearest your hand right now. It doesn't make a bit of difference whether you are the largest or the smallest exhibitor, the league *must* receive your cooperation in order that it may wield the influence you have a perfect right to expect of it, and which it will have if every exhibitor will give it his hearty cooperation.

An absolute need for a national league was never more plainly proven than by

the reduction accomplished in the war tax. Just imagine how much greater a reduction might have been realized had we but had a proper organization.

Do you realize the absolute necessity for the national league to receive promptly the per capita tax from the various state branches? We know that nothing can be accomplished without money.

the exhibitors alone. The national executive board is giving their untiring efforts—the very best that is in them—and don't you think that they should at least receive your encouragement and support through your cooperation?

Strong Enough to Aid All

I don't want to continually urge the payment of money. I don't want to harp on financial needs to a degree that proves unpleasant.

But I never want to see a time when some exhibitor, no matter how small he may be, turns to this league of ours for advice, assistance, or aid of any sort, in times that are to him of the utmost importance, and for help that may prove vital to his individual business, and find that the league isn't big enough, strong enough, or influential enough to give that exhibitor every good thing he expected of it.

The only thing that will make this true will be lack of funds, which the exhibitor himself may have failed, in the past, to provide.

It isn't lack of interest—it isn't that the average exhibitor doesn't realize that some day, under some circumstances, he may want to ask of the league something of tremendous importance to him and his own individual business, that prevents him from doing his part to provide the league with the necessary equipment, financially; but it simply amounts to the fact of not having been brought home to each exhibitor with the forcefulness, the importance, and (if you please) the "punch" that will make an active, helpful factor for the league of each exhibitor, instead of a man who means well, intends to do his share sometime—but merely wants a bit of friendly urging to make that "sometime"—NOW.

WHERE TO FIND IT	
Department.	Page.
Live Wire Exhibitors.....	37
Looking Ahead	39
Exhibitors' Forum	41
In and Out of Los Angeles Studios	42
Among the Exchanges.....	47
Feature Reviews.....	49, 50, 60-66
Editorials	51
Program Reviews	83-85
Current and Coming Releases..	86-87
Release Dates for Ready Reference	88, 93, 94
Weekly Release Chart.....	115
ACCESSORY NEWS	133-146

And do you realize that the officers have advanced hundreds of dollars of their own money to further the interests of a league that is trying to be of a great benefit to you? Do you know that a number of states are crying for a national organizer to assist them in organizing, and re-organizing their states—and that the only financial resources we have is through our per capita tax?

Of course, we could probably get all the money we needed from other sources, but should this happen we would cease to be an organization that was working for the interests of the exhibitors and

Fischer Elected President of Milwaukee Branch

Olinger Is Made Vice-President, Harry Graham, Treasurer—Frank Cook, William Jacobs, Henry Trinz, E. Langwack Become Board Directors

Special to MOTION PICTURE NEWS
Milwaukee, Wis., Dec. 8.

AT the annual election of officers held at the regular meeting at the Plank-ing Club rooms, Friday afternoon, the Milwaukee Motion Picture Exhibitors' Association elected George Fischer, president; J. B. Olinger, vice-president; Sam Trinz, secretary, and Harry Graham, treasurer. Frank Cook, William Jacobs, Henry Trinz, E. Langwack and Bert K. Fischer were elected to the board of directors, and Oliver Bradford as sergeant-at-arms.

The meeting was a record one and the election was hotly contested. The election of Sam Trinz as secretary to succeed himself was in recognition of the splendid work he has done for the association during the past year in that office.

Owing to the fact that it was impossible to secure a definite date for the use of the Auditorium, it was decided to call off the ball which had been announced for January 30. It was discovered that an error had been made relative to the date the Auditorium would be available and, rather than accept a later date, it was decided to call the ball off. This action has caused a great deal of regret among exhibitors and their friends, as the members of local film circles have looked forward to the affair with considerable interest.

This move on the part of the Milwaukee exhibitors will come as a distinct disappointment to the photoplay world as a whole, as well as the local exhibitor, but circumstances were such that no other move was possible.

J. W. MARTIN.

SUNDAY OPENING CASES DISMISSED

Special to MOTION PICTURE NEWS

Nashville, Tenn., Dec. 8.

The cases of W. H. Wassman and William Hartman, proprietors of local motion picture theatres, charged with operating their houses on Sunday, were dismissed at a hearing in police court. Mr. Wassman is proprietor of the Crystal and Rex theatres on Fifth avenue, while Mr. Hartman owns a motion picture playhouse on Cedar street.

The defense attacked the constitutionality of the ordinance prohibiting the operation of places of amusement on Sunday. The disposition of these cases, it is believed, will result in the opening of a number of other motion picture theatres and places of amusement on Sunday.

AUGUST SELECTS CAST

Edwin August has begun to cast for a new picture which he will produce and in which he will star for the Kinetophote. He is selecting several well known film people for the parts and expects to start work at the Kinetophote studio at Coney Island within a week.

BETWEEN SCENES AT SANTA BARBARA

Louise Lester has started her annual "Do Your Christmas Shopping Early," at the American Studios in Santa Barbara, Cal. Miss Lester says her campaign will reach all her friends in Santa Barbara this year.

NEW HAVEN UNIVERSAL MOVES

The Universal Film Exchange, New Haven, Conn., branch, has removed from 850 Chapel street to its new, thoroughly equipped office at 227-229 Meadow street.

Great Northern Picture Filmed in Sweden

"The Adventures of Gar El Hamar," Staged Amid Beautiful Scenery of the North, Features Hertel, Continental Star

THE Great Northern Film Company's latest feature, entitled "The Adventures of Gar El Hama," is an unusually picturesque production. It was staged amid the beautiful rugged scenery on the southern coast of Sweden, on the high

thus secured. Three different kinds of seagoing ships were utilized in producing this photoplay, namely, a schooner, a tug and a yacht. The latter belonged to the American magnate, Mr. Singer, of the Singer Sewing Machine Company.



AN UNUSUAL SCENE FROM "THE ADVENTURES OF GAR EL HAMA" (Great Northern Feature)

seas between Denmark and Sweden, and on a deserted island in that vicinity. That section is unsurpassed for scenic splendor by any other coast locations.

Many novel and spectacular scenes were

Mr. Singer visited Denmark last summer, and while he was there the Great Northern Company arranged to use his handsome yacht in the picture. Many different views of the yacht were photographed, including a picture of the engine room. Some very thrilling incidents were enacted on the yacht.

The title role in the photoplay is portrayed by the prominent continental dramatic star, A. Hertel, who also essayed the name part in the two former Gar El Hama pictures. This actor recently distinguished himself by his wonderful acting of a difficult character part in the recent Great Northern feature, "After Thirty Years." In the present production, he is surrounded by a strong supporting cast.

Kinetophote Markets Hollandia Pictures

American Company Will Release Through K. C. Booking Films Made in the Land of the Dykes—Jan Leendertz on Visit to United States

THE Kinetophote has just completed arrangements with the Hollandia Film Manufacturing Company, Haarlem, Holland, whereby the Kinetophote will take over such of the Hollandia pictures as are available for the United States, Canada and New Foundland.

Such films as the Kinetophote takes over will be released through the K. C. Booking Company, Inc., in the United States and the K. C. Booking Company, Limited, of Montreal, as well as through the exchanges affiliated with the K. C. company.

Jan Leendertz, representative of the Hollandia company, arrived in this country on the *Rotterdam* a week or more ago, bringing with him 25,000 feet of film, a part of which was accepted by the Kinetophote as being of sufficient merit to take with American audiences.

Mr. Leendertz, who is an expert in the land of dykes on the question of motion pictures, is stopping at the McAlpin, but expects to return to Holland on the *Nieuw Amsterdam* when that ship sails on December 12. Mr. Leendertz knows the film game in Holland from start to finish and talks most interestingly of conditions in

the business there which have arisen as the result of the war.

"Our company is the only company in Holland manufacturing films and we find an excellent market for our output. We do not, however, market any of our films ourselves; we sell through the oldest agent in Holland, who distributes films all over Holland and Dutch colonies.

"But we do not have the proposition of a feature every day in many motion picture theatres, such as you do here. In Holland a theatre books a feature for one week or, at the most, two each week.

"After the war broke out there was a great boom in the motion picture trade because so many of what you call the legitimate theatres were closed. At once there was a demand for a cheaper amusement and the motion pictures supplied it. However, prices were lowered a little in the film houses, due to the depression caused by the war, and because there was a fear that Holland might be dragged into it. Now we know that we shall not be implicated in the controversy, and things were brightening up to a considerable extent when I left Holland."

BLACKWELL MAKES THOROUGH PREPARATION FOR EACH PLAY

Carlyle Blackwell, of the Favorite Players, has his own way of preparing for his photoplays. There is virtually a committee of four to discuss productions. The scenario writer prepares the script and it is then discussed by Carlyle Blackwell, William D. Taylor, his assistant, Henry Kernan, and the writer of the photoplay.

The script will probably be altered and another evening spent in licking it into shape, two if necessary. The costumes and sets are then discussed and decided upon and numerous drawing made. Finally, the company is picked, types being selected, and the photoplay is read to them, after which every member of the company is furnished with a copy of the script to study. Many rehearsals are then held before the play is started.

THE TRANSFORMATION OF A NICKEL TOWN

By Louis Marcus

Denver, Long in the Throes of a Five Cent Nightmare, Due to Cut-Throat Policies of Exhibitors Failing to Realize the Fate in Store for a Manager Who Employs Unbusiness-Like Tactics, Is Beginning to Observe the Slogan, "Live and Let Live"

EDITORIAL NOTE.—*Louis Marcus is the pioneer film exchange man of the inter-mountain territory, being one of the first to enter the business and one who has watched the growth and development of the industry from its infancy. As president and general manager of the Notable Feature Film Company, with head offices in Salt Lake, there is probably no other man in his territory who is better posted on conditions past and present.*

CONDITIONS in Denver are improving. Exhibitors in the Queen City of the Plains have long held the reputation for being the most aggressive and tenacious showmen in this inter-mountain country, whose struggle for existence has been accompanied by cut-throat methods and a suicidal policy, while the slogan has been, "No matter if you lose money, don't let the other fellow get any patronage."

This short-sighted course has resulted in Denver being universally known as "the Nickel City of the West." Newspaper writers unacquainted with the inside workings of the film business apparently gloried in this dubious distinction for their city, while numerous other conditions contributed to this unenviable quality.

In vain did the various exchanges operating in the territory endeavor to arrive at a solution of the problem. The proposition was seriously discussed at one time of a gentlemen's agreement whereby the distributing agents would decline to provide more than a certain number of reels to an exhibitor operating a five-cent house.

It was proposed to establish a clearing house on bookings so that this agreement could be maintained. However, as the United States District Attorney might look upon such a move as being one in restraint of trade and bring to bear upon the exchanges the Sherman anti-trust law, this was abandoned.

Now the situation is beginning to adjust itself. The ice has been broken and the writer predicts that the day is not far distant when the nickel theatre will give a nickel show, and the better class house will cater to the classes, as it should be.

No Ten-Cent House for Years

For years there has been no ten-cent house in Denver. True, occasionally when a manager has advertised a special feature he has advanced the price for the time being. His competitors promptly have put in the strongest subjects available and kept the price at a nickel. A case in point occurred last spring when one house presented "Les Miserables" at twenty cents, and the Isis promptly put on "Million Bid" at a nickel!

The Plaza, it is true, started in on a ten-cent basis. Unfortunately it was unable to get a suitable program; it was summer-time, business was poor and everything was against the successful operation of the proposition.

Today a great number of the theatres in Denver not on Curtis street are running one or two nights each week on a ten-cent basis. This condition is not altogether a happy one, for it confuses the public, and people coming down town for an evening's enjoyment never know what they are going to pay or see.

The constant changing of programs, inadequate advertising that always is associated with the frequent change and the sand-wiching in of mediocre programs with productions of merit, all contribute to placing the business in Denver on a chaotic basis.

Denver will pay ten cents. That was proved recently when the Isis turned over to the Red Cross Association a sum in excess of \$400, which represented the box office receipts for the day.

Both theatres and exchanges realize that the advent of a new era in the motion picture business, as far as Denver is concerned, is at hand. The opening wedge came with the capitulation of the neighborhood houses, and now the advance is closing in on the Curtis street citadel. It was hard work to convince the neighborhood houses that they could get ten cents—provided, of course, they furnished their patrons productions of merit.

York Leads Way to Ten Cents

The first to see the light was the York, a pretty suburban house, which started to exhibit the Isis five-cent productions for a dime. Judiciously advertised, the experiment proved an unqualified success. The Colfax, Bide-a-Wee and Rex, which at first would not listen to the proposition of a ten-cent night, fell into line and are making money out of Lasky, Famous Players, Bosworth and other productions of similar caliber.

Now the opening gun has been fired on Curtis street at the Princess Theatre, by George H. Greaves and his associates, who can be justly named the pioneers of the ten-cent show in Colorado, and whose experience has been that when you

have the wares you can get the business.

The Princess Theatre has been redecorated and a number of improvements instituted, including the installation of an orchestra of twenty musicians. Paramount, World and Alco subjects are shown exclusively, and the public apparently is recognizing a good thing.

The Princess is one of a string of motion picture theatres in Colorado operated by Mr. Greaves and his associates. In Colorado Springs, Pueblo and Cheyenne they were the pioneers in advanced prices, and Mr. Greaves' success has encouraged others to raise their prices, but it was a hard fight, as always is the case in pioneering.

The newspapers in the past have been an obstacle, because to the newspapers all motion pictures look alike, but the press, too, is seeing the light and the flippant writer who used to scoff at "the movies" now is beginning to wax enthusiastic over "motion picture productions."

Importance of Films Recognized

Where they hurt the game a year ago, they are now paving the way in educational fashion, and when the Denver "Post" concedes that there are lots of good pictures worth more than a nickel, times verily are changing!

When men of the calibre of F. W. White, the veteran dramatic critic on the "Post" and Richard Milton, of the "Times," take up motion pictures seriously as they have done, and segregate them into classifications to assert that the best and most pretentious productions warrant better prices, the dawn of an equitable adjustment is at hand.

There will always be room in Denver for five-cent houses, but even "The Nickel City of the West" is beginning to concede that it has come to the parting of the ways, and the big production with its huge initial outlay in scenic effects, salaries for great artists and the hundred and one expenses connected with the modern production merits an advance in prices, even if only to uphold the good old adage of "live and let live."

Movement for Higher Prices in Washington

Leader Has Ten Cent Scale on Sunday, Garden Raises Gallery Prices, Penn Gardens a Ten-Cent Feature House—Patrons Offer No Objections

Special to MOTION PICTURE NEWS

Washington, D. C., December 8. **A**RISE in prices is becoming more general in the Capital City. The Leader, which has always offered an excellent five-cent program, asks ten cents for its Sunday shows, when an extra feature is added. The week days continue at five cents, except on occasions of exceptional productions.

Moore's Garden Theatre has raised its gallery prices to ten cents, with no diminution in attendance. In the residential sections the Sunday admission has almost be-

come universally ten cents, and a mid-week performance is also of the same price. The Auditorium asks fifteen cents on feature nights.

The opening of the Penn Gardens offers an exclusive feature house in the residential section with a ten-cent program that is well worth the money.

The encouraging aspect in this condition is that there is small complaint on the part of patrons, and more encouraging still is that there is no appreciable decrease in attendance at these theatres. The public is demanding more elaborate photoplays,

which are more costly and should bring a higher price of admission.

It appears that the public is ready to meet this demand and are satisfied with the performances offered. Of course there are still the nickel shows for those who cannot pay more or who will not pay more, and in these houses patrons certainly get their money's worth.

THEODORE FRANKLIN.

TWO ST. LOUIS THEATRES RAISE PRICES

Special to MOTION PICTURE NEWS

St. Louis, Dec. 8.

H. Steinmeyer, proprietor of the Chipewa Theatre, at 3807 South Broadway, is gradually raising the admission prices of his house. When the place first opened, ten cents was charged, but competition arrived and the prices were forced down to five cents. Mr. Steinmeyer managed the place for a long time at that price, and then, as an experiment, he began charging ten cents on Sundays and holidays.

There was no falling off in patronage; the people seemed just as willing to pay ten cents as they did five. Of course this was not done until a reputation was established by the theatre which guaranteed that a good and well-selected program would be shown.

Ten cents is now the rule for Sundays and holidays, and in a very short time that price will be the standard for all performances.

The Carroll Theatre, at 1500 South Broadway, has raised the admission price to ten cents on Sundays, when a six-reel program will be given instead of the regular four reels that are used ordinarily.

LIMITS FIVE CENT PROGRAM TO THREE REELS

Special to MOTION PICTURE NEWS

Los Angeles, Dec. 7.

Believing three reels is sufficient for a five-cent theatre program, W. W. Dunlap, manager of the Comedy Theatre, 542 South Broadway, which was formerly the "Exclusive" for women and children only, has smashed precedent in that respect, and furthermore will run all future programs two weeks. The smallest program in Los Angeles and surrounding cities consists of four reels, while the average is six reels. Some of the retail district theatres show as many as nine reels for five cents. Comedy pictures will constitute the program at the Comedy.

This new plan has been used for the past four weeks and is a winner. The Saturday and Sunday receipts are almost as large as those of the other theatre owned by the same company, diagonally across the street, where ten, fifteen and twenty cents are the prices and six reels are shown. The larger house has more than 800 seats, while the Comedy has less than 300.

WASHINGTON THEATRE OWNER KILLED IN ACCIDENT

Dr. W. H. Wunder, former owner of the Maryland Theatre and member of the syndicate which built the Imperial Theatre, now operated by Tom Moore as the Garden Theatre, died in Washington, D. C., last week as a result of an automobile accident.

1,200 Extras Used in Bosworth-Smalley Film

"False Colors," Produced Under Supervision of Lois Weber and Phillips Smalley, Contains Striking Theatre Interior Scene

A FEATURE film unusual in plot and strong in dramatic action is "False Colors," by Lois Weber, and produced under the personal direction of Mr. and Mrs. Phillips Smalley. It is a daring story, unfolded in a dexterous manner, and is car-

sincere in her interpretation of a woman who loves. The rest of the cast includes the well-known screen artists, Adele Farrington, Courtenay Foote, Charles Marriott, Herbert Standing and Dixie Carr.

One of the spectacular scenes is the in-



(LEFT TO RIGHT) LOIS WEBER, PHILLIPS SMALLEY, HERBERT STANDING AND DIXIE CARR IN "FALSE COLORS" (Smalley-Bosworth)

ried out artistically by convincing acting. "False Colors" is so named for the reason that it exposes the futility of deceit and hypocrisy. Phillips Smalley plays the title role of Lloyd Phillips, the actor, and Mrs. Phillips Smalley (Lois Weber) is

terior of the theatre, for which 1,200 people were engaged. Credit must be given to Dal Clawson, the camera man, who has achieved some remarkable effects in the numerous pictures produced by Bosworth, Inc.

Keystone Wins Marie Dressler Injunction Suit

Justice Newberger Denies Application of Actress to Restrain the Company from Disposing of "Tillie's Punctured Romance" to Alco Corporation

JUSTICE NEWBERGER, of the Supreme Court of New York State, on Tuesday denied the application of Marie Dressler for a receiver of the picture, "Tillie's Punctured Romance," and an injunction restraining the Keystone Film Company from disposing of the picture to Alco Film Corporation, her claim being that both parties jointly owned the picture, and that she had not been consulted about the disposition of it.

The defendant, through its attorneys, Graham & Stevenson, exhibited the contract to the court, which, while giving Marie Dressler a right in the negative, gave the Keystone Film Company the right, so that company claimed, to handle the picture and dispose of it as it thought best, and Justice Newberger denied the plaintiff's application and said:

"Plaintiff claims that under paragraph fourth of her contract between her and the defendant, that the pictures of the play in which the plaintiff acted as star should always remain the joint property of both parties, and should not be sold, only rented

and leased; that the defendant has threatened to sell and dispose of the same. The defendant denies that it intends to sell or dispose of the films, but proposed to lease the same for certain territories on what is known as 'state rights' basis. I can find nothing in the moving picture papers that would warrant this court in holding that the disposition proposed by the defendant would be a sale, or that the plaintiff would be injured by any such act. The application for a receiver and an injunction pendente lite must be denied."

YOU CAN'T FAIL

to find what you want in

MOTION PICTURE NEWS

because

MOTION PICTURE NEWS IS MADE TO
MEET EVERY ONE OF YOUR WANTS
BY MEN WHO KNOW WHAT
YOUR WANTS ARE.

PATHE SERIAL MARKS ERA IN FILM HISTORY

Arnold Daly, with International Reputation as Impersonator of Characters in Shaw Dramas, Will Appear in "The Exploits of Elaine," by Arthur Reeve, Who as Author of the "Craig Kennedy" Detective Stories Ranks Next to A. Conan Doyle

THE new Pathé serial, which will succeed "The Perils of Pauline," and the first number of which will be released on December 28, is to be called "The Exploits of Elaine."

Those who say that there is nothing new under the sun may be correct in the strictest sense of the word, but the fact remains that there occasionally appears something which if not absolutely new is such an ingenious combination of things already known as to appear actually novel.

the readers' attention closely, but an added value is given to them by the fact that his hero makes use of genuine scientific methods in the detection of crime.

The author keeps so closely in touch with the newest discoveries in all branches of science that he is able to solve mysteries by means which are as genuine as they are startling. An example of this is furnished by the case of the detectaphone. In some of his earliest stories of the exploits of "Craig Kennedy" Mr. Reeve had his hero make use of the detectaphone, an instrument which at that time was known to only a few persons.

Not long after the Detectaphone Company of America wrote to Mr. Reeve saying: "We feel that to 'Craig Kennedy' is due the fact that Mr. Burns has adopted the detectaphone for all his work, at present having nearly 100 machines at the disposal of his offices."

Story Will Be Widely Spread

So effective is the use which Mr. Reeve makes of new devices which might be of value in detecting crime that many such instruments have been sent to him by the manufacturers with the request that he make use of them in his stories.

This is Mr. Reeve's first work for the screen, but there is no danger that the scenarios will suffer for this reason, as he is collaborating with Charles L. Goddard, the author of the "Perils of Pauline." Each installment will be written out by Mr. Reeve as a short story, and these will be published not only in all the Hearst newspapers throughout the country, but also in leading newspapers in almost every city or town of any size.

This widespread publication of the story will give it a great amount of advertising, and should make it an easy thing for an exhibitor to keep his patrons posted.

The cast of the picture is another feature which deserves special comment. In the title role Pearl White will be seen. Miss White's work in "The Perils of Pauline" has made her very popular with all of the followers of that picture, and she should prove equally attractive as Elaine.

A most important change from the preceding serial will be made in the matter of the leading man. Arnold Daly will appear in this part. Mr. Daly, who is one of the most widely known legitimate actors in this country, has appeared only once before in motion pictures. Judging from his work on that occasion and his established reputation as an actor, Mr. Daly should do



ARTHUR B. REEVE

To look for such a state of affairs in serial films might seem unduly optimistic, since these productions have appeared on the market in such large numbers, but there seems to be every reason to believe that the new Pathé serial, "The Exploits of Elaine," will be decidedly unusual, to say the least.

In the first place, there is the strongest possible assurance that the stories will be good ones. This is a most important point, and one that manufacturers are too likely to overlook. The mere throwing together of a series of events, however exciting they may be, can never be as effective as a carefully worked out plot written by someone who knows story construction.

"The Exploits of Elaine" are being written by Arthur B. Reeve, author of the "Craig Kennedy" stories which have been running in the "Cosmopolitan Magazine" for the past four years. Mr. Reeve is without any question one of the foremost short story writers of the present day, and in the field of detective stories probably has no equal, unless it be A. Conan Doyle.

Reeve Stories Unusual

Mr. Reeve's stories are of an unusual sort. The episodes on which they are based and their plots are of a nature which hold



CHARLES L. GODDARD

much to increase the popularity of the new serial.

Leo Wharton, who has been directing Wharton films for some time, will be the director.

The general scheme of the serial will be to present a series of high class scientific detective stories. Instead of thrills created by smashing property, there will be those caused by tense situations and marvelous achievements of science. The first picture will be called "The Clutching Hand." There will be fourteen episodes of two reels each released weekly.

Hill Explosion Thrills "Zudora" Episode

Earth Mound, Domicile of Two Inventors Who Make Contrivance for Setting Fire to Distance Objects, Blows Up in Part Five

AN entire hill more than one-quarter of a mile in circumference was blown up in episode five of "Zudora," Thanhouser's big serial. This hill is the home of two aged inventors who have given to the world an instrument which makes a "perpetual glare." This contrivance, too, can set any object on fire at a distance of several miles. Hassam Ali, played by James Cruze, uses this invention to further harass his niece, Zudora, given admirable portrayal by Marguerite Snow.

Harry Benham, in the role of John Storm, traces the source of this mysterious

power, after he and Zudora have almost fallen victims to it. Hassam Ali, seeing he is about to be discovered and his treachery made clear, decides to do away with Zudora and Storm at the same time. The hill is mined and the master fuse laid to a safe spot where Hassam Ali and the inventors watch.

Storm destroys the "perpetual glare" machine and Hassam Ali gives the signal to touch off the charge. It goes. And with such force that the big hill is sent skyward, clouds of earth flying hundreds of feet.

Screen Magnetism Distinguishes Blanche Sweet

Eighteen Year Old Star, Who Signs with the Jesse Lasky-David Belasco Forces, Gains Reputation for Variety of Achievements at Early Age—Her Versatility Exemplified in a Wide Range of Plays
Calling for Exercise of Rare Artistic Judgment

BLANCHE SWEET, the announcement of whose engagement to star in the new series of Jesse Lasky-David Belasco picturizations of Belasco successes, has been one of the most notable news events of the past few weeks in the moving picture field, is famous among picture artists for the variety of her achievements at the age of only eighteen. Her picture appears elsewhere in this issue of *MOTION PICTURE NEWS*.

Of course, it must be remembered that Miss Sweet began young, and under the most expert direction—but even making all allowances for youth and instruction there can be no question about her versatility.

From "Judith of Bethulia" to "The Escape" is a far cry indeed; and from "The Escape" to "The Warrens of Virginia," "The Woman," "Sweet Kitty Bellaire" and other Belasco offerings means a series of even greater contrasts.

As a question of artistic judgment it is interesting to note that David Belasco and Cecil B. De Mille, who directs the Belasco productions for the screen, should have chosen a girl whose reputation has been made solely and entirely in pictures.

MISS SWEET was once on the legitimate stage for a short period, but it was at the very beginning of her career.

She was discovered by D. W. Griffith, who was then at the height of his fame as a producer, because there was something about her type that was obviously suitable for photography and because she had that responsive temperament so essential to obtaining realistic effects.

It has been said of Blanche Sweet that she does not act; she merely does things. Weeping, laughing and the other extreme emotions cannot be faked, even in part, for the screen, as they can be faked for the stage, with the turned back and the heaving shoulders—and the artist all the time thinking of something quite different in no way connected with the drama itself. In pictures, on the contrary, the audience demands direct visual evidence of the emotions, and crying must be obvious, and to be obvious it must be real. The same is true of laughter, and of the expressions of love and hate. Just as the picture screen is no place for a stage kiss, so the screen is in almost all respects far more important in realism than the stage.

And Blanche Sweet has in her beautiful face, her fine young body and her expressive hands a wonderful instrument on which to play the gamut of emotions. The underlying spirit is willing, curiously quick to respond to suggestions of all sorts, and the flesh is almost miraculously a mirror of what passes in soul or brain.

THE wonderful fact of Blanche Sweet is that she does not act; instead, she lives through the experience of the stories which she is made to interpret with such fervor that the audience correctly believes it is not witnessing the illusion of life but life itself.

Personal magnetism for the screen is one of the most puzzling of all qualities. Half of the men and two-thirds of the women who have magnetism for the stage somehow lack it when only the shadow of them appears before an audience. Magnetism is a mystery; some people contend it is a sort of electric connection linking artist and audience and that a picture, moving or otherwise, cannot properly be magnetic.

Yet Blanche Sweet absolutely proves this not to be the case. For the man doesn't live who could watch a good Sweet picture without feeling a sense of her actual presence—without almost believing that he could touch flesh if only his hand could come in contact with the figure on the screen.

In other words, the personal magnetism that is screenable is a rare and unusual attribute, for, with many women, so much of personality is conveyed by intonations of the voice and oddities of enunciation and articulation.

To speak of the personality of a picture may seem almost an essential contradiction, but Blanche Sweet proves that the artist trained to the expression of emotions in silence and naturally gifted in that manner may acquire a photographic personality in motion pictures.

YOUR imagination conveys to you the sense of touch just as if the picture were a woman in the body. What she "says in silence" is so real that, though she

has marvellously mastered the difficulty of suppressing lip movement, you almost hear the voice.

It is even possible for the millions who have seen her for the last three or four years, always seeing her in silence, to imagine what her voice would be like; for her actions indicate a fullness of youthful charm which would seem to make a rich voice natural.

Nobody is aiming to make Blanche Sweet just a pretty girl on the screen. On the contrary, she will have the widest range of opportunity in the Belasco dramas, and the ambition of Mr. De Mille is that she shall be not only great in appeal but supreme as an artist in her field of endeavor. For there is less place on the screen than on the stage for the ingenue, and Miss Sweet is too vital with personality herself to be or to consider being the sweet little thing of the sort that has won Broadway dramatic success in high comedy of a certain domestic sort.

LOTS of big scenes, hundreds of thrilling incidents, a wide variety of great emotional opportunities are waiting for the eighteen-year-old Lasky star. But this does not mean that her name is to be connected with the dramas of the unhappy side of life. On the contrary, youth and sympathetic appeal make her particularly adapted to interpret the happy and joyous emotions, and the new Blanche Sweet will be the star of sunshine.

Crown City Studios Teeming with Activity

Company Making Two Paragon Reels and One Thistle a Week for the Kriterion Program at Pasadena

THE producing companies of the Crown City Film Manufacturing Company at Pasadena, Cal., making two reels of Paragon drama and one reel of Thistle brand comedy weekly for the Kriterion program, are hard at work getting out the first releases.

The dramatic company is under the direction of Donald Macdonald, with a cast of Dorothy Davenport, Ben Horning, Lee Hill and Felix Modjeska are now engaged in filming "The Adventurer," a Raffles story, after having completed three others each of two reels. The title of these are "His Brother's Wife," a society drama; "The Crystal Globe," an East India mystery story, and "The Doctor," a character study featuring Ben Horning, of San Diego Mission Play fame. All of these subjects are from scenarios by Anthony W. Coldey, head of that department and studio manager.

The Thistle brand company is under the direction of Bruce Mitchell and Rena Rogers, and Allen Fralick will be featured. The stage for the company's studio will be 60 by 60 feet, and is nearing completion. The laboratory building is being con-

structed of concrete, is 30 by 60, and will contain a large and spacious projection room.

The officers of the company are: M. Spero, president; F. A. Ryan, vice-president; D. E. Baird, secretary; H. A. Parker, treasurer, and R. D. Sorver, auditor, all of Pasadena and Los Angeles.

A LESSON IN CO-OPERATION

Special to *MOTION PICTURE NEWS*

Detroit, Dec. 9.

Co-operation is to supplant competition among the three moving picture theatres of South Haven, Mich., located on Lake Michigan in the western part of the state. Their owners have agreed to try for a month the closing of two of the houses and holding all shows at the O. K. Theatre, the largest.

Should the trial prove satisfactory, the plan will be continued until June 1, when the other two houses will re-open to provide for the crowds that usually come during the summer season.

Managers of all three houses will get a share of the O. K. Theatre's receipts during the winter months.

If I Were An Exhibitor

A few friendly "words to the wise" from the patron who always has ten cents to spend in the right theatre, spoken, not in a spirit of criticism, but to give the man on the inside the benefit of the outside point of view.



IF I WERE AN EXHIBITOR, I would not stay in any little cubby hole of an office tucked away under the balcony stairs any longer than was necessary to give an extra shine to my shoes, or a little touch that might serve to spruce me up and make me more pleasing in appearance to my audience. I would be in the lobby, in the box office, up and down the aisles, everywhere, that I might know everything that was going on, and always at the instant call of attaches or patrons of the house.

IF I WERE AN EXHIBITOR, I would make friends with every man, woman and child that visited my theatre, and when I noticed a stranger, I would do like all the popular preachers do—I would lay for that fellow and I would say a pleasant word to him, I would ask him how he liked the show, and I would invite him to come again, and send him away with the feeling that my theatre was a pleasant place to visit.

IF I WERE AN EXHIBITOR, and the doormen or ushers encouraged their friends to stand around the door or in the aisles talking to them, I would fire those ushers or doormen bodily if they did not stop the practice.

IF I WERE AN EXHIBITOR, I would try to impress on every one around the place that loafing, by either the employees or patrons of any business, is fatal to the business. I would have it understood that there must be no loitering in the lobby. There are only two things people should be doing around a well conducted theatre, they should either be standing in line at the box office waiting for a ticket, or coming out of the exits with a pleasant reminiscent smile on their faces.

IF I WERE AN EXHIBITOR, and had to close my theatre during the hot months, I would give the place a thorough scrubbing when I opened up in the fall, and I would save all the soap wrappers and all the empty cans of cleaning compound used in the process, and I would make a display of them with a neat card calling attention to the public that my theatre had been treated to a good old-fashioned bath, and I would point to the number of pounds of soap and speak of the thousand gallons of water used, and I would thereby get myself and my theatre talked about. Folks would say, "They are clean down at the Cineamatograph Palace, or the Theatorium, or the Dreamland Auditorium."

IF I WERE AN EXHIBITOR, I would demonstrate that I had gray matter enough to pick a sensible, appropriate name for my theatre, instead of behaving as foolishly about it as the light-headed woman who lives on paper-covered novels and names her daughters after their heroines.

IF I WERE AN EXHIBITOR, I would think twice before I plastered the front of my theatre with posters until it looked like a cross between a cut-price drug store and a subway excavation. German students glory in faces scarred and seamed with sabre-cuts, swathed in bandages and stuck with court plasters, but that is no reason why an exhibitor should apply the same principle to the front of his theatre.

IF I WERE AN EXHIBITOR, I would beat everybody to it on the censorship proposition, and prove to them all, from manufacturers in the trade to city officials out of it, that I could

do my own censoring better than anyone could do it for me. I would show them that I could give a clean show, no matter how humble my theatre and the people to whom it catered. And I would start a new kind of censorship that would be as merciless against the cheap, badly produced picture as against the flauntingly immoral and suggestive one.

IF I WERE AN EXHIBITOR, I would decide in my own mind, once and for all, just what kind of a show I wanted to give my patrons, and then charge them a price that would yield me a profit and be justified by the pictures. It might be a nickel. It might be a quarter. But if I made up my mind that I couldn't charge more than five cents, I wouldn't lay myself open to the charge of insanity by loading myself with the costliest features I could find, knowing I could never break even on them, in a mad endeavor to beat my competitor down the street. I would give my patrons the best five-cent pictures to be had for a nickel, and when I couldn't resist the temptation to rent a film that ought to bring ten, fifteen or twenty-five cents, I would have the sound horse sense to charge the right price for it.

IF I WERE AN EXHIBITOR, and had a gum-chewing cashier, and she was too valuable to discharge and I could not break her of the habit by moral suasion, I would buy a large supply of jaw exerciser and give her a night off with instructions to do all her chewing in a lump, and get it over with. Under no condition would I allow her to Fletcherize in the box office.

IF I WERE AN EXHIBITOR, and a photoplaywright were to ask me to show a picture that had been made from his scenario, I would run a slide announcing the fact that "Mr. Ferdinand Umph, of 1415 Neighborhood Avenue, will have a film at my theatre on a given night," and I would pretty near pack the house that night, because nine out of every ten people who come to the theatre are trying to write plays, and they all want to see what the other fellow's stuff looks like; and I would make an everlasting friend out of the writer and all his friends.

IF I WERE AN EXHIBITOR, I would study my audience. I would find out what kind of pictures they want, and to do that I would use the method that I will use to count the words in this article when it is finished. I will not count each word, space writers' time is too valuable for that, I will just count every tenth line and average the rest up by that standard, and I would use the same method in measuring up my audience. I would stop every tenth patron some night and ask his or her opinion of the show, and when I had talked to about six or seven, I would have a pretty fair notion of what the people in the neighborhood wanted, and then I would give it to them.

IF I WERE AN EXHIBITOR, and a patron were to tell me that there were pictures shown in my theatre that he did not like, I would not go into a long-winded explanation of how I was tied up with an exchange and did not know what my program was to be till I got it. If such were the case, I would be ashamed to admit it.

IF I WERE AN EXHIBITOR, I would preach organization to my fellow exhibitors. I would forget trying to beat my competitor; instead, I would get in touch with him, organize with him, fraternize with him, and in a short time, instead of being enemies, we would be brothers, fighting and overcoming most of the evils that now beset our industry.

FLORENCE LA BADIE IN "CRAFT VERSUS LOVE"

"The Million Dollar Mystery" fans will have an opportunity to see their favorites in "Craft Versus Love," a forthcoming two-reel feature release by Thanhouser.

Florence La Badie, the heroine of the famous serial in the lead, has an unusual chance to display her great histrionic ability so wondrously set off by her girlish charm. Supporting Miss La Badie is Sidney Bracy, known country-wide as Jones the Butler.



SCENE FROM "CRAFT VS. LOVE"
(Thanhouser)

Mr. Bracy offers a remarkable contribution to the silent drama in "Craft Versus Love." The combination of Miss La Badie and Mr. Bracy has brought scores of telegrams of congratulations to the Thanhouser management, which shows how these two stars stand with the country's motion picture fans.

CHANGE OF DATE IN EDISON RELEASE

The Edison company have found it necessary to substitute for "Mr. Daly's Wedding Day," announced for release December 28, a comedy drama, "The Calico Cat," wherein the droll comedian, William Wadsworth, is at his best as the eccentric old man whose hatred of cats involves him in a criminal case. Unable to resist a shot at a calico cat, he apparently shoots an Italian stealing chickens.

The lawyer fastens the charge on a young boy. The amusing situation is complicated by the old man being drawn as one of the jurors, whose conscience continually bothers him, finally forcing him to confess—to find that the injury was trumped up, the exposure coming by a woman's detective work. The one-reel photoplay is an adaptation of the story by Mr. Charles M. Thompson.

EDITH STOREY AND HUGHIE MACK AT BOSTON BALL

Edith Storey and Hughie Mack, of the Vitagraph Company, were in evidence at the Exhibitors' Ball of Boston, Mass. Hughie's imposing presence and expansive smile were notable features, and Edith Storey's popularity was evidenced by the recognition she received when she entered the Boston arena.

Pike's Peak Company to Make Westerns for United

Colorado Company, Newly Organized, Will Produce Pictures Depicting the Life of the West Under the Brand Name of Lariat

NEWS has just been received of the organization of the Pike's Peak Film Company at Colorado Springs, Col., as a unit of the recently-organized United Motion Picture Producers, Inc. The new firm is to produce Western pictures for the daily program being released by the United Film Service. In keeping with the character of its output the firm has adopted the brand name of Lariat.

Otis B. Thayer is the producing director of the new company. Thayer will be remembered as the producing director of the Colorado Motion Picture Company, which filmed "Across the Border," released by the Warner's Features, Inc., now known as the United Film Service, in its augmented

form, last July, and in the making of which the leading woman, Grace McHugh, lost her life, while attempting to ford a stream.

Charles Gebhart, whose appearances in the past as leading man with the Bison, Vitagraph and Edison companies had made him possibly the most familiar leading man of the day, and who recently was general director of the Ramo Features, will appear in the leading roles of the new series, acting, also, as assistant of Mr. Thayer.

The leading woman of the Pike's Peak Film Company is Josephine West. Miss West is an adept horsewoman, versed in the use of the lariat, and a hardy mountaineer.

A. H. Sawyer, Inc., Increases Capital Stock

Company Files Papers for Authorization to Raise Figures from \$500,000 to \$600,000 and Change Name to Sawyer Film Corporation

KEEN interest has been excited by the announcement that A. H. Sawyer, Inc., has filed papers for the increase of its capitalization of \$500,000, making the total capital stock issue \$600,000. There was also filed a change in name, and hereafter the Sawyer interests will be called the Sawyer Film Corporation.

Six months ago A. H. Sawyer, known as one of the brilliant men in filmdom, started his film mart with a relatively small capital. His idea in starting was to progress only on a firm business basis, and to try out his marketing ideas before going too heavily into the investment. This was just at the critical period when, it is said, the bottom dropped out of state rights selling propositions, and Sawyer was the first in the field to start establishing a chain of branch or zone offices to handle an output of feature films from an international basis.

Today the Sawyer field organization comprises twenty-six zone offices in the best feature film distributing points in the United States and Canada, and these zone office affiliations are with the leading feature film exchanges of the country.

The New England territory is handled by the Phoenix Film Company, of Boston; the Chicago district by the Union Film Company, of which Joe Hopp, president of the Standard Program Association, is the leading spirit; in Montreal the Allied Features has the main Canadian office; and in Philadelphia the Interstate and Fairmount exchanges handle the Sawyer business.

Representative men are in charge of the other twenty offices, making the Sawyer marketing forces as well represented as that of any company in the field.

Contracts were recently concluded by which one of the largest English film concerns will handle Sawyer pictures on the other side of the Atlantic.

The increase of capitalization has been forced upon Sawyer by the expansion of business which the last few weeks have witnessed. A syndicate of downtown

bankers are all ready to take the new stock issue, and it was on their urging that the increase was made.

The Sawyer Film Corporation will inaugurate a new policy, inasmuch as in addition to its system of marketing film for manufacturers, with increased capital it will be in a position to purchase feature films negatives outright, and will also finance producing companies releasing exclusively through it by giving cash advances on royalties of negatives turned over to it for marketing.

DYREDA SIGNS DE BELLEVILLE

The Dyreda Art Film Corporation has signed Frederick De Belleville to act in a feature motion picture which will be produced under the direction of J. Searle Dawley.

Mr. De Belleville is one of the best known actors in this country and has long occupied an important place on the Ameri-



FREDERICK DE BELLEVILLE

can stage, having been leading man for Minnie Maddern Fiske, James O'Neill, Rose Coghlan and others.

Mr. De Belleville will be seen for the first time in motion pictures in the feature, "A Daughter of the People," which will be released through The World Film Corporation some time in January.

Live Wire Exhibitors

EDITOR'S NOTE.—It is the desire of "Motion Picture News" to include under this heading novel advertising ideas, successful schemes in the management, decoration and equipment of the theatre—everything, in fact, done by the exhibitor to stimulate his trade. We invite every exhibitor to write us about any new enterprise he has; also to come to us for advice or information along any line. Address: Editor, "Motion Picture News," 220 West Forty-second Street, New York City

A PLEA FOR HIGHER PRICES

S. I. SHAFER, manager of the Empress Theatre, Montrose, Colo., has raised his prices, says "Real Reels," the house organ of the Notable Feature Film Company, of Salt Lake City, and in a neatly printed announcement to his patrons says among other things:

"Some people say that a picture show is not worth more than a dime.

"To claim that there is only one admission price due on a moving picture is worse than foolish. It is an open statement that whatever they paid for clothes twenty years ago is the price they pay today. And it may be so. But if they pay no more today than they did twenty years ago, their appearance will tell the story.

"The twenty-cent picture means no more to us than the ten-cent one from a standpoint of profit. If we charge you more to see the picture it is a sure thing that we pay more to get it. The respect of our mental development demands that we get the best.

"Nothing would give us greater pleasure than to be able to present nothing but the great productions made in moving pictures, featuring the great actors and actresses of our day. The prestige gained for this theatre from showing the best is worth more than all the dollars we may ever hope to make. Remember, we are trying to please you, but to do so we must have your help and friendship."

HOW A WOMAN PLANS TO RUN A THEATRE

A NEW theatre that has just been opened in Washington, D. C., is the Elite, situated in the residential northwest section. It is a neat and attractive house, with a seating capacity of three hundred and fifty. This is a ten-cent theatre, with five cents for children, and the program will always include a feature, which is at present being selected from the General Film specials. Arrangements are being made to include the big productions of other corporations.

The Elite is equipped with two Edison simplex projection machines, which permit the showing of pictures without interruption. This theatre is under the management of C. W. Madert, who speaks encouragingly of the outlook for business.

From the attendance and the aspect of the theatre outside and in, the observer is aware that the Lafayette has changed hands, and this to advantage. The present

manager is Mrs. A. C. M. Sturgis, who had this to say about her policy: "I mean to keep the Lafayette clean, comfortable and well ventilated. By the frequent use of the big exhaust fans, the air in the theatre is changed in four minutes, and by the hourly spraying with a perfumed deodorizer the atmosphere is kept healthful and pleasant.

"It is attention of this nature that is a strong point in a woman's management of a picture house. Already I have been able to increase the attendance of women and the young folks. My program will include the best that can be afforded by a five-cent house. I am making arrangements to show the suffrage play, 'Your Girl and Mine,' and I mean to do all I can to interest the women in the Lafayette, and I am inviting suggestions from my patrons as to what they want. That is the best way to create good fellowship between manager and patrons and an effective manner of studying your attendance."

Mrs. Sturgis claims her pianists are among the highest paid, as she believes this is an important asset to a house.

The music is in the able hands of George Emmonds and A. L. Oehmann.

CONVERTING BIRTHDAYS INTO CASH

MANAGER FRED SEIGERT, of the Columbia Theatre, 2117 West Jefferson street, Los Angeles, has a semi-annual feature for his theatre that is a winner.

Six months ago his little daughter celebrated her birthday anniversary, and Mr. Seigert invited all the children of the vicinity to attend the "party" at the Columbia, where it took two separate performances to entertain all as the seating capacity consists of only 400.

The other day he gave a "party" for his little son's birthday. At each he had motion pictures made of the children, which are shown for several evenings, in addition to the regular program, and at regular prices, ten cents. More than a thousand children attended the son's "party."

"ANNIVERSARY WEEK"

THE Family Theatre, Cincinnati, recently decorated its lobby by draping it with smilax and bunting and a neatly printed card hung from the middle of the lobby, announcing that the theatre was celebrating "Anniversary Week."

Manager Libson strained every nerve to give his patrons something unusual in his programs the week in which he celebrated the fourth anniversary of the theatre.

THE PROPER ATTITUDE

THE Manhattan Photo Play Theatre at 109th street and Manhattan avenue, New York City, has sent out a circular letter to its patrons, that has some very good points in it. In fact, parts of it are especially worth mentioning. One paragraph contains the following:

"We ask you to help us make this theatre—the popular theatre in this section—it should be YOUR theatre—for without your co-operation we cannot hope for success.

"On your patronage depends our financial future and we heartily solicit your support. We will aim to please, and if by chance we fall short of our mark—tell us, for we are but human, and if we do make mistakes, they are of the head and not of the heart.

"We invite criticism and solicit your hearty co-operation." The communication is signed, "Yours for 'Manhattan Success,' Gertler & Halpern."

Herman Gertler, formerly with Warner's and World Film Companies, is the manager and on the programme issued by the theatre he states, "We aim to present an assorted entertainment of photo-plays accompanied by and interspersed with selected musical numbers.

"We may find it necessary at times to change our programme or make substitutions, in which case, we will be pleased to refund admission fees if our patrons are disappointed with the substituted pictures."

SUCCESSFUL RESERVATION OF SEATS BY PHONE

AN arrangement whereby patrons may phone for reserved seats has been instituted at the Butterfly Theatre, Milwaukee. The Butterfly contains long rows of box seats on each of the aisles. Although the general admission fee is ten cents, double that amount is charged for the box seats. Patrons phone that they want a certain number of seats in a particular box.

As the box seats are not numbered the cashier puts away the correct amount of tickets and then tells the usher to reserve the desired seats until a certain hour. When Mr. and Mrs. Patron arrive their seats are awaiting them. Mr. Graham, the manager, believes in making his audience feel that an effort is being made to add to their comfort, and consequently realizes that the plan is well worth the small amount of trouble his employees are put to. A slide announces this convenience, and Mr. Graham hopes to win over the regular theatregoers to the realm of film drama.

Live Wire Exhibitors

CHECK YOUR CIGARS

THE Washington theatre, at Delmar avenue and Kingshighway, St. Louis, has an absolutely new wrinkle designed for the comfort and convenience of its patrons. At the side of the box office is a rack holding eight neat and attractively decorated porcelain cigar containers, each with a number at the top; to the right of this is a rack with eight metal rimmed checks, each bearing a number corresponding to the one on the container. A neat sign invites patrons to check their cigars before going in the theatre.

The patron needs no help or attention from any one; he simply takes a check from the rack and puts his cigar in the container bearing the duplicate number; on coming out he takes his cigar and hangs the check back on its proper hook. A large, generously filled match box is kept hanging in close proximity to the cigar check rack.

E. V. Dittlinger, Jr., son of the manager of the Washington, is the inventor of the idea.

HE WANTS PHOTOGRAPHS, NOT GLARING POSTERS

HARRY CRANDALL, proprietor of Crandall's Theatre, is the first man in Washington, D. C., to possess and display the life-sized portrait of Alice Joyce before his theatre. This is a work of art, "a symphony in green," and it at once attracted the passers-by.

The picture shows Miss Joyce of the Kalem Company wearing a \$3,000 gown with a million dollars' worth of jewelry.

"I consider this one of my biggest advertising assets I have yet ventured into," said Mr. Crandall, "and if I could get all the photoplay stars in pictures of this class, I would do away with glaring posters."

LOOKING AFTER THE KIDDIES WITH CHILDREN'S DAY

HOW to attract afternoon crowds to his two theatres in an outlying residence section beyond the shopping district is a problem that J. M. Lenney believes he has solved, at least in part.

Mr. Lenney is proprietor of the Lenney theatre, 5 to 7 South Thirteenth street, and the Grand, a new house he has just constructed at Fourteenth and Derry streets. Both houses are in a part of Harrisburg where motion picture theatres depend on neighborhood patronage rather than on transient patronage, as is the case with theatres in the business sections.

A "neighborhood" theatre, Mr. Lenney finds, has no trouble attracting large houses in the evenings, but to run it in the afternoon under ordinary circumstances is far from profitable. The theatres in the business sections are patronized in the day time by people who find them convenient resting places during shopping trips or sources of temporary relaxation from business cares, but the theatres beyond the region of the office buildings and shops are likely to be empty in the afternoons unless some special inducement is provided to attract the neighborhood folk from their homes before evening, when they turn out in large numbers.

The overhead expenses of a motion picture theatre in these days of city taxes, state taxes and—what may come in the near future, federal war taxes, are very heavy and make it almost essential to devise a method of attracting profitable afternoon crowds. With this in mind, Mr. Lenney has hit upon a plan, the details of which he is now working out, to give matinee shows twice a week in his two theatres, the performances to be designed especially to appeal to children.

Mr. Lenney believes that he will be able to obtain enough films on subjects of interest to little folks, such as fairy tales or similar pictures, and with this in view he is now in communication with various film dealers to learn whether he can regularly obtain enough pictures of this class to make his project possible. If he finds that he can get enough children's films to fill out programs twice each week he is going to open his theatres each Wednesday and Saturday afternoon and advertise special children's shows. He expects in this way to attract not only the little folks, but also their parents or other grown-ups who will go along to "look after" the youngsters.

Mr. Lenney proposes to advertise his children's shows extensively, not only in the newspapers, but by sending circulars to the parents of all the school children in his section of the city, and, if possible, to interest the school authorities.

WORKING A BOOSTERS' NIGHT

"BOOSTERS' NIGHT" proved a big success for the Broadway Theatre, 2404 North Broadway, Los Angeles. Manager D. S. Mitchell induced ten merchants—one of each line—to give one dollar in trade to patrons, once each week, of the theatre who held the lucky numbers, in exchange for a mention on the screen at each performance, and a 28 x 42 card with all names on in the lobby.

"The ten dollars' worth of merchandise orders bring the people to the theatre on Booster Night," Mr. Mitchell said in telling of his new business-getting plan, "and the scheme has created the best bunch of boosting merchants for my show of anything I have ever heard of. Everyone of the ten merchants send their patrons there.

A SEXTETTE OF STARS IDENTIFIED WITH PRODUCTIONS ON THE MUTUAL PROGRAM



LILLIAN GISH

FLO LA BADIE

RHEA MITCHELL

WINIFRED GREENWOOD

MARGUERITE SNOW

MABEL NORMAND

Looking Ahead With The Producers

"THE THREE OF US" RELEASED DECEMBER 14

Mabel Taliaferro has just completed her first work before the camera in B. A. Rolfe's production of the famous play, "The Three of Us," in which Irving Cummings, Creighton Hale, Edwin Carewe and Madame Claire play important roles.

Miss Taliaferro, best remembered from her work in Frederick Thompson's production of "Polly of the Circus" and Klaw & Erlanger's production of "Springtime,"

prominent producing concern commissioned a famous English author to create a part for her, equal to that of Maude Adams in "Peter Pan."

Miss Taliaferro is now working at the Rolfe studios, Yonkers, N. Y., and her first effort, "The Three of Us," will be seen on the Alco program, Monday, December 14. The actress is contracted for by B. A. Rolfe for appearance in several other picture productions, announcement of which will be made later.

Edith Taliaferro by the terms of which Miss Taliaferro is to be seen in the near future in an elaborate photo-dramatic production.

Miss Taliaferro will be remembered as a leading artist in such widely-known Broadway productions as "Rebecca of Sunnybrook Farm" and "Young Wisdom."

For Miss Taliaferro's photo-drama debut Mr. Lasky has selected a play entitled "Young Romance," which is by William C. De Mille. The production will be directed by Cecil B. De Mille, brother of the author.



MABEL TALIAFERRO

created so favorable an impression upon the occasion of her most recent appearance here in "Young Wisdom," in which she was supported by her sister, Edith, that a

"THE SHADOW," AN EXCELSIOR RELEASE, WELL ACTED

The next Excelsior release will be entitled "In the Shadows." This story is taken from the book "The Shadow," by John B. Hymer, and is a story of the loyalty and friendship of two men starting in their college days and continuing through a series of incidents, in which one of them is suspected of murder.

Through it all runs the love of the hero for the sister of his chum and companion, and she by her grit and ready wit aids in unravelling the chain of circumstantial evidence which tends to the false conviction of her future husband. Throughout the story the breath of open-air life, and the sweet purity of true affection are strongly characterized in the actions of all the principals in the story.

The competent players of the Excelsior Feature Film company aptly portray the stirring events that occur throughout the five-reel story of this photoplay.

ROUNAN IN NEW YORK WITH ANIMAL FILMS

John Rounan, of the E. and R. Jungle Film Company, who recently came to New York City from Los Angeles and is now stopping at the Hotel Hermitage, intending to remain in the city for several days, has brought with him two two-reel, one three-reel and one one-reel animal pictures taken at the Los Angeles studio of the company.

The zoo contains one of the largest collections of rare animals in the country, enabling the company to produce pictures of extraordinary interest. The E. and R. Jungle Film Company announces the near completion of other unique animal pictures of great educational value. The studio is located at 1720 North Soto street, Los Angeles.

JESSE LASKY ENGAGES EDITH TALIAFERRO

Samuel Goldfish announces that a contract has been concluded between Jesse L. Lasky, as president of the Jesse L. Lasky Feature Play Company, and Miss

EDNA GOODRICH ON WAY FROM EUROPE FOR LASKY FILM

Edna Goodrich, equally famous as dramatic star and stage beauty, is at last on the way home from Europe to fulfil her contract with Jesse L. Lasky to star in

A FEW OF THE STARS TO BE FOUND ON THE SCREEN IN FAMOUS PLAYERS FEATURES



MARGUERITE CLARK



EDWARD ABELES



MARY PICKFORD



JOHN BARRYMORE



MARIE DORO

Looking Ahead With The Producers

one of the leading productions of the Jesse L. Lasky Feature Play Company.

Miss Goodrich was unfortunately in Europe at the beginning of the war and had some very thrilling experiences in Ostend. When she finally managed to get to London she was so exhausted that she had to recuperate under medical treatment. After a few days in New York City, Miss Goodrich will leave for the Lasky studios in Hollywood, Cal.

"GARDEN OF LIES" COMPANY BACK FROM FLORIDA

Jane Cowl, the widely successful dramatic star, who makes her screen debut in the Alco release, "The Garden of Lies," has just returned from St. Augustine with the party which the All-Star Feature Corporation sent to the old Florida city for the making of the exteriors in the Justus Miles Forman story.

The party was under the general direction of John H. Pratt, chief director of the All Star, and Assistant Director George Kline. Members of the supporting cast included: William Russell, David Wall, Philip Hahn, Claude Cooper, Ethelbert Hales, Adele Carson and Violet Horner. The party left New York on November 22.

"The Garden of Lies" was successfully produced in the legitimate in London by Sir George Alexander. The scenario was written by Louis Reeves Harrison.

MARIE LA MANNA, A YOUNG STAR

Less than a year ago Marie La Manna, an eighteen-year-old schoolgirl, had no theatrical aspirations, but today she is a stellar attraction of the Edison company. She has been selected for the principal part in the company's new five-part feature spectacle, "Fantasma," released December 19.

Miss La Manna is possessed of rare beauty, made more appealing by a girlishness, vivacity and sweetness that no acting can simulate. A mixture of French and Irish blood, she represents the charm of the beautiful Irish colleen and the vivacious French girl.

Following her success in "Fantasma," she was cast for the lead in "In His Father's Footsteps," soon to be released, and is now in the South working on a Southern play.

ROSSMAN IN CHARGE OF WATKIN CIRCUIT

Earl Rossman, Gloversville, N. Y., is at present in charge of the circuit of theatres controlled by the H. W. Watkins Enterprises. He was manager for William Morris at the New York theatre.

Los Angeles Screen Club Plans Charity Ball

Occasion Scheduled for Early Part of January in Shriners' Auditorium, and Twenty-five Per Cent. of Receipts Will Be Devoted to Worthy Causes

Special to MOTION PICTURE NEWS

Los Angeles, Dec. 7.

THE gratifying news that the San Francisco Screen Club cleared more than \$2,300 by a dance given there Saturday evening, November 28, has served to revive the desire of members of the Los Angeles League, and at the meeting held Wednesday the initial plans were made for the biggest event of the kind ever pulled off on the west coast.

When the question was brought up the reason stated for the need of funds was the proposed legislation which California exhibitors must try to keep off the statute books. Already five bills are prepared for introduction and it is probable there will be others.

The committee selected to make all arrangements for the ball will be composed of Seth D. Perkins, of the Optic theatre, chairman; J. S. Lustig, Starland; Bert Lustig, National; Vick Parks, Photoplay, all of Los Angeles; and H. W. Warner, of Pasadena, Cal.

While plans have not been definitely made, it is the intention of the committee to invite President Pearce, of the Exhibitors' League of America, to lead the grand march, and in all probability his partner will be selected by a popularity contest either conducted by the theatres of Los Angeles and Southern California or through the sale of tickets.

Arrangements will be made for all the leading photo-players of the west coast, fully 90 per cent. being engaged at Los Angeles studios. Between the numbers of the dance it is planned there shall be vaudeville acts given by actors and actresses. The date will be set for early in January and the ball will be held at

the Shriners Auditorium, the largest building of its kind west of Chicago. Twenty-five per cent. of the net receipts of the ball will be given to charity, the organization to handle the fund to be announced later.

Another important matter brought before the exhibitors at this meeting was what is termed unjust treatment of an exhibitor by a local exchange. At a recent meeting a committee was appointed to investigate the charges made by Seth D. Perkins, manager of the Optic theatre on Main street. After hearing the report of this committee, a motion was made providing that resolutions giving details of the treatment accorded the theatre manager, the view the members of the league take of the treatment, and their recommendations be prepared by the local officers and copies be forwarded to the president of the company in New York. The motion was carried unanimously.

J. C. JESSEN.

"AD" AIDS FOR "MASTER KEY" EXHIBITORS

The Universal Company besides bringing out clever pictures taking instantly with the public and assured of long runs by their appeal to all tastes, aids the exhibitor with unique advertising matter.

For the "Master Key," its latest serial, a thirty-reeler, the company has prepared for the use of managers who desire to conduct an effective publicity campaign, a cloth herald in the form of a pennant. The pennant is made from substantial blue felt on which is pasted a white cloth key. At the base of the triangle appears the name of the theatre booking the film.

It is a clever device which cannot fail to attract attention, and will act as a constant reminder to patrons taking it home as a souvenir.

SELIG ZOO OPENING IS PROMISED FOR FEBRUARY

It is probable that the great Selig Jungle-Zoo at Los Angeles will be opened formally the early part of the new year. Just how near February 1 this can be effected still is a question, but it will not be far from that date. First, there will be a special exhibitors' day, when theatrical men from far and near will be guests of the management. Next will be the official opening for waiting Los Angeles. Mr. Selig will be present upon both occasions.

ONE OF THE "ORIGINAL SIGNERS"

Motion Picture News, New York City.

Gentlemen: We have been reading the "News" for about two years, ever since it has been sold by the Wilkie News Co., the first firm to sell it on a news stand here, that we know of, and, in the words of the immortal discoverer of the "River of Doubt," it is "Bully."

Very truly,
FAMOUS FEATURE FILM CO.,
Per J. M. Kramer, Pres.
Dayton, Ohio.

The Exhibitors' Forum

Motion Pictures Should Have More Sub-titles

New York City, Dec. 4.

Editor, MOTION PICTURE NEWS,
New York City.

Dear Sir.—Why do so many producers imagine that they must bring out pictures practically without sub-titles? By some curious kink they have become obsessed with the idea that a screen drama cannot measure up to the highest standards of the motion picture art unless the story is told only in pantomime.

To my mind, and in the opinion of the vast majority of patrons, this is a mistake. And it is a serious mistake, for if the practice is carried to the limit people will begin to lose interest, due to the impossibility of keeping track of a plot without the exercise of fatiguing concentration.

People go to see pictures to be amused, and not to be compelled to keep their attention glued so hard to the story to find out what it is all about, that they use as much gray matter as if they were trying to solve a mathematical problem. Such compulsion is far from relaxation. It is a hard task. Nobody wants to go to the theatre in that spirit.

Consequently, if the "tired business man," who wants to divert his mind, finds that his evening's entertainment is going to defeat such a purpose he will soon get out of the habit of dropping in the nearest motion picture house for recreation. He will feel that solving chess problems to win the prizes in the Sunday papers, or trying to dope out their "strategy" editorials on the war, means less work for his jaded brain.

Producers should not lose sight of the fact that an audience expects to be amused. No one expects to see a play on the "legitimate" stage with the dialogue left out. No manager would ask his audience to sit through the four acts in a dead silence, depending upon the gesticulations and facial expressions of the players to follow the story. Why then should any one expect the same sufferance from motion picture audiences?

Sub-titles in motion pictures correspond to the speeches of the legitimate drama for a complete understanding of the development of a plot.

I have been told that some producers are influenced by the supposition that pantomime is the logical model for photoplay acting. On the face of it, this appears to be true. But on a closer inspection it will be found that this idea is based on a half truth.

I grant that a story told solely by pantomime is the best method for effective work in motion pictures—if it were possible. But, unfortunately, it is not possible.

An important part of pantomime is facial expression. Human passions are best shown through the lineaments of the features. Without it there would be no pantomime, but it must be remembered that on the legitimate stage the audience can see the faces of the players from practically every angle. Thus nothing necessary to carry on the action is lost on the spectators.

But in the case of motion pictures the moment the actor tries to convey the emotion felt by the character he is portraying solely through grimaces the player is compelled to look directly into the camera. This action is generally accompanied by a feeling of self-consciousness which spoils the effect. Hence pantomime is impracticable on account of the camera's limitations.

Let us have more instead of fewer sub-titles. A continuance of the popularity of motion pictures depends upon this vital matter.

EARNEST PROTEST.

Force vs. Persuasion

Detroit, Dec. 4.

Editor, MOTION PICTURE NEWS,
New York City.

Dear Sir.—It seems to me that the best way to get theatres to live up to the rules of the association is not by using "strong-arm" methods, or to do anything antagonistic.

For instance, if one theatre offers four or five reels for five cents, the theatre nearest him feels that it has to do the same. If this complaint would be referred to the association and then a committee appointed to call on the proprietor or manager, that would, in a diplomatic way, point out the evil that comes to the industry by giving more than the standard number of reels for the price, I am sure that the theatre proprietor or manager in question would gladly change his tactics and "give in."

Some theatres do things because they do not know any better, not because they deliberately want to be contrary to the general rules or understanding.

No man in business likes to have a club held over his head and told that he must or must not do certain things.

I don't want to say that such tactics have been used in Detroit, but I just want to call attention to the fact that a personal talk with the wrongdoer will do more good than trying to force him to come your way.

A PROMINENT EXHIBITOR.

The News Release Pages

Dec. 7, 1914.

Editor, MOTION PICTURE NEWS,
New York City.

Dear Sir.—Just a line or two to let you know that I have at last secured through

MOTION PICTURE NEWS what might seem small in your eyes, but looms up in great proportions in mine.

My operator showed me the other morning a copy of your paper and pointed out to me the release pages, and to say that I was pleased would be putting it mildly.

It was just what is needed, in my mind, for an exhibitor that wants to keep tabs on his show.

You no doubt know that the film exchanges designate all their reels with numbers, and I was delighted when I saw these numbers attached to the titles of the releases on the pages specified.

It seems to me the ideal way of giving the exhibitor the information as to coming releases, and no doubt I am not the only one to have so voiced my appreciation. It certainly fills a long felt want, and I am going to have a special holder made so that I can file them in order.

The pages will go far to speak for the enterprise of your paper, and, coupled with the page designated as "Ready Reference" on which the different features are listed by companies and programs, there is no better help for the harassed exhibitor.

This letter is rather longer than I had intended it, but I feel that I cannot thank you enough for the release pages of the MOTION PICTURE NEWS. With best wishes for the paper that is really a paper for the exhibitor, believe me,

Gratefully yours,

A JERSEY EXHIBITOR.

Hoboken, N. J.

MINNIE DUPREE SIGNS WITH LIFE PHOTO

The Life Photo Film Corporation has secured an option on the services of Minnie Dupree, the vaudeville and legitimate star, to appear in a forthcoming five part feature release to be produced by that company.

The Life Photo will shortly announce a succession of five part feature releases, adaptations from stage plays, options having been secured by them on twelve of the greatest dramatic successes produced in this country.

The Life Photo Film Corporation, beginning with January, will produce two 5-part features a month. It is possible that the additional program will be released under another name.

ARLINE PRETTY ACTS AS BRIDESMAID

Arline Pretty, who at present is supporting King Baggot in "A Five Pound Note," was recently bridesmaid for one of her nearest friends, a moving picture actress well known in filmdom. Miss Pretty plans to spend the Christmas holidays at home.

In and Out of Los Angeles Studios

Special to MOTION PICTURE NEWS

Los Angeles, Dec. 7.

PLANS for Christmas festivities are being made by the photoplayers of practically every studio in the Los Angeles district. Every studio will be closed on both Christmas and New Year's Day, and in some instances extra work is being done on Sundays that vacations of several days may be taken by players.

Daily, scores of actors and actresses are taking part in benefits for raising money to spread Christmas cheer, working with club and social workers in raising money for such funds. For two weeks leading players have been taking part in productions at the local theatres, where a portion of the receipts go to this or that fund, or for the children's hospital, where over 700 children, under six years, are daily treated free.

Managers of this institution a few days ago announced that it would be necessary to close the hospital about the first of the year for want of funds. Many of the leading people of the studios immediately offered their services, and it is expected that



E. J. LE SAINT (Selig)

by the first of the year sufficient money will be in the treasury for another year's expenses.

Romantic Story of Mission Days

Elsie Janis is now appearing before the Bosworth camera for her second release, this being a picture from another story by the actress herself, produced by Phillips Smalley. The title is "Betty in Search of a Thrill," and in this four-reeler, of the order of a comedy-melodrama, the international star will pull off a score of new breath-shortening stunts on land and sea. Owen Moore, late of the Famous Players, will play opposite Miss Janis, and the cast will be made up of the star players of the Bosworth stock company.

Lois Weber Smalley last week took up the filming of "Captain Courtesy," from the story and play by Edward Charles Carpenter, in which Dustin Farnum played the leading role. This is a very romantic story of the nature of Robin Hood, with scenes laid in California and Mexico in the year of 1846—the Mission days.

Macklyn Arbuckle has finished his engagement with the Bosworth players, and returned to the East. This feature, which was made under the working title, "Hi Judd, Old Sunshine," was from a story by



SCENE FROM "IN TUNE" (American-Mutual—Released December 14)

Mr. Arbuckle, and included in the cast are: Phillips Smalley, Adele Farrington, Frank Elliott and Myrtle Stedman.

In the making of one of the last scenes for "Buckshot John," Hobart Bosworth, playing the name part and enacting an escape of a convict, dashed across the track in front of a fast approaching limited train, and so close did the front of the locomotive come to hitting him that members of the producing company expected to find him along the right of way after the twelve coaches passed. The camera was stationed so near the tracks that it was impossible for the crank turner, George Hill, to operate in the usual way, but instead he pushed the handle with the tips of his fingers.

Manager Albert Kaufman, Allan Dawn, Cameraman H. H. Broeing and Jack Pickford, of the Famous Players company, have arrived here and begun the production of "The Pretty Sister of José," with Marguerite Clark in the leading part.

For the present the company will work at the Bosworth and Lasky studios, but ul-

timately will lease or build a studio which will be used permanently by one of the producing companies, it being the intention of the managers to keep at least one producing company in Los Angeles all of the time. James Kirkwood and Mary Pickford and others will come to the West Coast about the first of the year. John Mason will come here to play in "The Fatal Card," and Hazel Dawn in "The Love Root."

There are several new faces at the Sterling studio, Johnny Brennon and Lloyd Ingraham both having been signed by Manager Fred Balshoffer.

"Innocent Dad" Burlesque

Director Frank Griffin has filmed "Innocent Dad," with a cast including Gus Erdman and Dot Gould. This is a burlesque on Father, who is taken into speedy society by his son.

Lloyd Ingraham is playing the role of a temperamental French chef, filmed under the direction of David Kirkland for the Sterling brand, and to be released under the title, "The Chef's Revenge." And even though the papers are daily telling stories of the expected shortage in beef because



MACLYN ARBUCKLE (Bosworth)

of the mouth and hoof disease, the props for this film consist of great juicy steaks, roasts and tempting chops, all of which take the place of cannon balls and bullets in the battle that is staged.

The juvenile company has made "Carmine's Romance," featuring four-year-old Billie Jacobs, under the direction of Robert Thornby. All the parts are played by children.

Director-General Cecil de Mille, of the Lasky studio, has decided that Blanche

In and Out of Los Angeles Studios

Sweet shall make her first appearance under the Paramount banner in "The Warrens of Virginia," the Belasco legitimate stage success by William C. DeMille, and the work of filming this was taken up last week. Included in the cast will be House Peters and James Neil.

Edward Abeles has returned to the Lasky

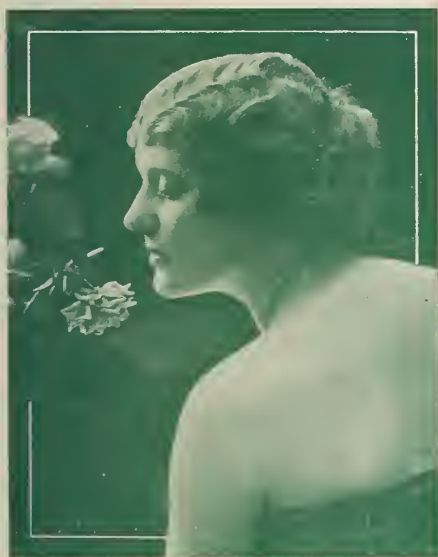

MARIE WOLCAMP

studio and is playing the featured part in "After Five," by William C. and Cecil de Mille, under the direction of Oscar Apfel.

"Golden West" Finished

Harry Woodruff is expected at the Lasky studio from the East within the next few days, but as yet it has not been decided what picture he will appear in.

The "Girl of the Golden West" was finished during the past week, and after projection at the studio was sent to the factory at New York. Edith Taliaferro has completed her work in "Merely Mary Ann," the stage success of Eleanor Robson, and has returned to New York to take an engagement in a new play.

Director Henry McRea, of the 101 Bison Universal company, is preparing a scenario for "Ridgeway of Montana," from the successful novel by William McLead Raine, which will be filmed in four reels with members of the McRea company playing the leading parts, as soon as the present production, "The Governor's Lady," is completed.

This picture will be completed in two reels, depicting a romance in which capital, labor and politics play important parts. In the four-reel production will be the third of the big features released on the regular Universal program. Arrangements have

been made with George Hume, millionaire owner of the big timber reserve at Hume, Cal., for exclusive motion picture rights, and all exteriors will be made there.

The mountains in that section are now covered with deep snow, and some of the big scenes will be those of the snow slides and snow storms. The first of the story is laid in the western mountain country, one portion in Wall street, and another in California mining district.

Six Reeler by Colin Campbell

"My Lady Peggy Goes to Town," from the story by the same name by Frances Aymar Mathews, will be filmed in six reels by Colin Campbell and company of Selig players, following the completion of "The Rosary." The scenario is being prepared by Lanier Bartlett, and the picture will consist of six reels. It was originally intended that Mr. Campbell and players should go to the Panama Canal zone for the filming of exteriors for "The Ne'er Do Well," from the story by Rex Beach, but it is found necessary to delay making of this picture because of climatic conditions in Panama at this time.

The Thistle Brand comedy company, of Crown Film Manufacturing Company, of Pasadena, took advantage of the Corona 301-mile road race Thanksgiving day and secured exteriors for "The Boob's Racing Career," in which Frank Moore, Rena Rogers and Allen Fraulic play the leading parts. Donald Macdonald's Paragon brand dramatic company of the same firm this week filmed "The Witness," featuring Dorothy Davenport, supported by Ben Horning and Lee Hall.

This picture is of a semi-western character in which the title character prevents the conviction of innocent parties by circumstantial evidence gathered by the prosecutor and his aids. Both subjects are for the Criterion program.

The Rex Universal company has completed the scenes for the fifth, sixth and seventh installment of the serial, "The Master Key," from the story by John Fleming Wilson, and scenario by Calder Johnstone. Number seven shows many of the beautiful scenes of San Francisco when the two leading characters, John Dore and Ruth Gallon (Robert Leonard and Ella Hall) make a trip over the city in a taxicab.

In the eighth episode, which will be taken up the first of the week, some of the principal scenes will be made at Southern California mines, where the destitute condition of the miners, following a close-down of the mines, will be depicted.

Busy Nestor Companies

Both companies of Nestor comedy makers were busy last week. Al. E. Christie made "When His Lordship Proposed," a

burlesque on royalty, with Lee Moran, Jack Dillon, Harry Rattenberry and Miss Billie Rhodes; and Eddie Lyons, with Victoria Forde and Stella Adams were filming "For the Good of the Cause," in which Mr. Newlywed has troubles in ridding his household of his mother-in-law, who is an ardent suffragette.

The Joker company produced two single-reel comedies by Phil Walsh. In "The Butler's Baby," a pug dog of the housekeeper, an elderly spinster, and the infant of the butler and housemaid, who have been secretly wedded, cause many trying moments for both the master and all members of the household when they get mixed in companion compartments of a large sideboard.

A persistent salesman, who wishes to be attentive to a nurse in charge of a demented man being taken to a hospital for treatment, is made the butt of a joke by the



LILLIAN AND DOROTHY GISH

nurse, when her patient escapes, in "All's Well That Ends Well."

The Wilfred Lucas Gold Seal Universal company is engaged in the production of "Their Hour," by Bess Meredith, which deals with a man and a woman whose home lives are everything but pleasant, and who meet while on vacations. During the hour they are together both come to realize they love each other, but in the end sacrifice their future happiness and return to their respective families. The leads are taken by Cleo Madison and Joe King.

Max Davidson and Fay Tincher are playing leads in "Cupid and the Pest," in which a printer, by a transposition of lines in the marriage license column causes embarrassment for two pairs of lovers and incidentally sees a way of causing his own

In and Out of Los Angeles Studios

temperamental sweetheart to fall for his line of talk. Tod Browning and Billie West also take part and the production is under the direction of Edward Dillon.

Irene Hunt as a Newspaper Woman

"The Exposure" is the name of the "sob sister" story in which Irene Hunt is playing the part of the newspaper woman, being filmed for the Mutual program at the Reliance-Majestic studio. In this the reporter shows up the detective and police force and finally brings the criminals to justice. For two days the producing company made scenes at the Los Angeles central station and receiving hospital.

Frank E. Woods, manager scenario department of Reliance-Majestic studio, dropped the remark that he occasionally enjoyed an auto ride. Within an hour there were salesmen calling on him from local buzz car agencies. The number of callers increased, and their persistency finally drove the scribe to prepare a statement to the effect that he was filing a petition in bankruptcy. This is not a scenario, but all rights are reserved.

Dark Cloud, the Majestic Reliance Indian actor; his wife, Dove Eye, together with Fred Burns and Vester Pegg, are playing parts in "The Navajo Maiden," a one-reel Western being filmed by Arthur Mackley with Irene Hunt in the name role. In this subject the unscrupulous acts of the white people in taking advantage of the native Indians is shown in a new and decidedly novel manner.

Production of "How Hazel Got Even" has twice been stopped. First, Director Donald Crisp, in charge of making this two-reel Majestic comedy, was taken ill with pneumonia. George Seigman was initiated as director. While on her way home from the studio Dorothy Gish, being featured in the subject, was run down by an automobile, and the wheel passing over

her foot, broke several bones, making it impossible for her to appear before the camera for several weeks.

In the comedy Miss Gish appears as a cashier of a restaurant, and her sweetheart drives a bus. Later he becomes a prize-fighter and his head swells. The cashier hires a strapping big cowboy to soundly thrash the pug, and in the negotiations a romance is started. Eugene Palette and W. E. Lawrence play important parts. The subject will be completed as soon as Miss Gish recovers.

Continental Picture Thrilling

Christy Cabanne is in charge of the direction of a four-reel subject for release through the Continental Feature Film Corporation, "The Lost House," from the story of the same title by Richard Harding Davis. This promises to be one of the most spectacular and thrilling productions of this company, the script containing many thrilling and novel situations. This is the story of a Kentucky heiress whose uncle determined upon securing all her legacy, plots to get rid of her by the aid of crooked physicians. She is finally rescued by a newspaper reporter discovering and telling the police of the plot against the life of the girl.

The police, in order to gain access to the building in which she is held, are forced to use gatling guns. The building is accidentally fired and collapses just after the girl and reporter are rescued. Lillian Gish is playing the part of the heiress, Fred A. Turner, the uncle, and Wallace Reid the reporter.

Francis Spottiswood Aitken, character actor of the Griffith-Mutual players, has a smile that won't wear off. The cause is that his little daughter, Frances, carried away the blue ribbon at a baby show recently conducted in Pasadena, Cal., the city of millionaires.

W. S. Hart directed and played the leading part in a decidedly western subject, "In the Sage Brush Country," which was completed at the New York M. P. company studio last week. The picture tells the story of a bandit who becomes smitten on the girl he starts out to rob, and when he finds another has kidnapped and robbed her of the money to pay off the workmen at her father's mine, while she is taking it from the express office to the mine office, he sets out to effect a rescue. The cast includes Rhea Mitchell, Herschel Mayall and Thomas Kurihara.

Lively Football Stars

An interesting football story is woven around the sacrifice of a player who tells his friend his secret of passing a ball, thus making the friend successful, in "The Scrub," produced at the New York studio last week by Scott Sidney. Many of the game scenes were made when Whittier and University of Southern California teams clashed on a local field. The pictures were later projected for the benefit of the University players, and when run through the projection machine slowly it was possible for some of the players to see where they made mistakes which cost their team points on the score.

Charles Swickard is directing the filming of a moonshine country story, "The Still on Sunset Mountain." In this the revenue officer falls in love with the moonshiner's daughter. The information he secures while deceiving the mountain people, makes it possible for the officers to raid the home of his sweetheart.

The girl is wounded but remains faithful to her lover, when he is captured by the law breakers and is to be shot. She aids him to escape. This is the first subject filmed by Mr. Swickard since joining the Inceville forces.

A QUINTET OF STARS TO BE FOUND IN THE BOSWORTH FEATURE FILMS



MARGARET EDWARDS

ADELE FARRINGTON

LOIS WEBER

ELSIE JANIS

MYRTLE STEDMAN

In and Out of Los Angeles Studios

Richard Stanton and a company of Domino, Kay-Bee and Broncho players spent a week at San Francisco making dock and water scenes for a coming release.

J. Barney Sherry, of the New York Motion Picture Company studio, known as The Irish Prince, and Mabel Normand, the Keystone Girl, led the grand march at the Beach pavilion, Venice, Thanksgiving evening, where a special ball was given for motion picture players.

Figman Company in "Jack Chanty"

Max Figman, director for Masterpiece productions; Elliott Clawson, scenario editor, and George Rizard, cameraman, have left for the upper region of the Sacramento River, in the northern part of California, where they will select locations for exteriors for the film version of "Jack Chanty," a novel by Hulbert Footner. They will return by way of the Yosemite Valley, where other locations will be selected. The setting of the novel is in Northern Canada, but the mountain country of Northern California affords similar scenery.

The David Miles Company, producing for Sawyer release, has filmed a picture which will consist of several reels. The title is "The Sibyl of the Films." This is a story of a fortune teller and some of the extravagant yarns she tells her clients are shown by fadeouts. In the end the faker is exposed. In the cast are: Linda Griffith, Charles Fleming, Charles Perley and John C. Brammell. The company has just completed making "The Girl Who Smiles," a drama featuring Linda Griffith. This is a heart interest story in which a girl brings peace and harmony into a discordant family.

Tom Mix and his band of cowboys at the Selig Glendale studio staged a Western during the past week, "The Stage Coach and the Girl," with the director, Goldie Caldwell and Lucretia Maxium in the leading parts. One of the big scenes is that of the coach turning over down the side of a cliff when the wheel came off at a sharp turn in the road, and this thrill was put over without anyone being injured, notwithstanding Mix and Miss Caldwell were on the box, and two were inside when the "accident" happened. This week the company is making a two-reel subject under the working title, "The Child of the Fray."

Selig Studios Active

Director Norval McGregor is staging a one-reel comedy, "The Clam Shell Suffragette," with Lillian Browne Leighton in the name role, at the Selig Jungle Zoo studio, which tends to disprove the everyday belief that this representative of the female of the species is of recent origin.

The time of the picture is the stone age, and many costly sets were required.

Every company of the Selig studios is working every minute of sunlight, as the players have been promised vacations during the holidays if their respective company is ahead a release or two. Lillian Leighton is assured she will have two or three weeks to spend in Chicago, and Edith Johnstone will visit relatives and friends at Philadelphia and Rochester, N. Y.

Carl von Pagh-Winther, known as the Baron, cameraman for the Balboa company, spent Sunday afternoon at the harbor at San Pedro, and later, while dining at a cafe at the beach town, discussed submarine boats of various types. From the time the Baron left the cafe until he ar-



SPOTTISWOODE AITKEN

ived at his hotel at Long Beach, he was shadowed by government officers. A few minutes later he was taken by Long Beach police to the central station and there questioned in a manner that did not hide the fact that the officers thought him a German spy.

It required President Horkheimer, of the Balboa company just twenty minutes to secure the expert crank turner's release. Local players say the mustache the Baron wears is the cause of it all.

Ruth Roland, for four years featured in Kalem releases, has been contracted to appear in Balboa releases, and will be featured in the coming prize series, to be known as "Who Pays?" for which the Balboa company will pay \$1,000 for the letter giving the best answer to the twelve two-reel subjects, each of which will be sep-

arate stories connected only in the fact that they bring out one of the leading social questions of today.

Miss Roland has been in pictures for the past four years, and since her first appearance before the camera has always played leads. For a long time she was associated with Johnny Brennan in comedy releases, and later was transferred to the Glendale Kalem studio, where she was assigned emotional and heavy dramatic parts.

Otis Filming Three Novel Pictures

The actress will take up her new engagement December 15, and will first play the leading female parts in the twelve releases, scenarios for which have been completed.

Director-General Otis Turner and his company of players are engaged in filming a three-reel release, "Changed Lives," scenario for which was written by the "Guvener" himself. Mr. Turner has also prepared the scripts for three additional "Sanford Quest, Criminologist," detective stories which will be taken up next.

A play based on incidents of the Civil War is being filmed this week by Edward J. LeSaint at the Selig Edendale studio, the title of which is "The Passer By." The plot contains a pretty romance in which a Yankee miss induces a friend to take her brother's place in the ranks in order that the brother may remain at home to earn a living for the family. The admirer is given a present as a token of love by the girl, which later serves to identify him when found on the battlefield.

HAINES IN CHARGE OF MUTUAL LOUISVILLE OFFICE

FRANK E. HAMMER, who has been manager of the Louisville, Ky., office of the Mutual Film Corporation since quarters were opened here a few months ago, has severed his connection with that company.

He has gone to Indianapolis. F. H. Haines, who has been in the Cincinnati office of the Mutual, has taken charge in Louisville.

CALMY RETURNS TO FRISCO

THE many friends of M. Calmy, formerly of San Francisco, were gratified this week to learn that this popular exchange man, who has had charge of the Denver branch of the Golden Gate Film Exchange since last spring, is to again make his headquarters in San Francisco and is to be an assistant of Sol Lesser.

Mr. Calmy is returning to San Francisco on account of the fact that the Denver branch has been disposed of to other parties.

STAGE FAVORITES WHO ARE APPEARING IN BOX OFFICE "PRODUCTIONS EXTRAORDINARY"



CHARLES RICHMAN

CLAIRE WHITNEY

WILTON LACKAYE

DOROTHY DONNELLY

EDMUND BREESE

THREE BIG FEATURES ENGAGE INCE'S ATTENTION

Thomas H. Ince rapidly is acquiring the title of "the busiest man in the movies."

He devoted the entire summer to two of his biggest features, "The Two Gun Man" and "On the Night Stage," and although they are scarcely off his hands, he now is superintending the production of a third masterpiece, "The Italian." "The Two Gun Man" is a seven-reel Western thriller that will serve to present William S. Hart in the stellar role. "On the Night Stage" is another Western story, but of a different type.

This will offer Robert Edeson, William S. Hart and Rhea Mitchell in a tri-star combination. "The Italian" is a tense dramatic narrative of the slums and will have George Beban as its principal.

"THE CRUCIBLE" NEXT FAMOUS PLAYERS RELEASE

Following her first triumphant appearance in motion pictures, in the title role of "Wildflower," Marguerite Clark will again appear on the Famous Players-Paramount program December 14, in Mark Lee Luther's powerful story, "The Crucible."

In this production Marguerite Clark portrays the role of Jean Fanshaw, at first hoyden and tomboy, unjustly condemned to a reformatory, but who later triumphs over the shame of her imprisonment and the sordid corruptness of her environment.

FERGUSON TO BOOK LARGE CIRCUIT

Frederick L. Ferguson, manager of the New York branch of the George Kleine attractions, Candler Theatre building, for the past year, has resigned. His action in relinquishing this position was resultant from his acceptance of a lucrative offer to book a large circuit of motion picture theatres throughout New York state. His headquarters, commencing next Monday, will be in the Strand Theatre building.

ALCO SIGNS THREE MORE THEATRES FOR "SPOILERS"

The New York Alco Exchange, which owns the state rights for New York to "The Spoilers," reports a brisk demand for this feature. The latest theatres to be signed are the Clinton Square, Albany, and the Case, Troy.

"Damon and Pythias" Finds Favor with Public

Picture Telling the Most Famous Friendship in the History of the World Attracts Immense Crowds at New York Theatre

THE Universal production of "Damon and Pythias" has won immediate favor at the New York Theatre, and is playing to good business. It has made a strong impression with its fascinating and dramatic scenario, its splendid portraying company, its great scenes and perfection in photography.

In addition to drawing splendidly with playgoers the feature appeals strongly to the Knights of Pythias, who are booking in large parties for dates during the engagement. Wednesday night, December 2, all of the lower floor and boxes were occupied by the Army and Navy officers stationed at Governor's Island, all of the harbor forts and the Brooklyn navy yard. Officers of the battleships Wyoming and Florida were also present. Twelve lodges of the Knights of Pythias of New York City were in attendance December 3, and large parties are being booked throughout the engagement.

To accommodate these and also the general playgoing public, extra performances

have been added at the New York theatres. From now on two performances will be given every Saturday and Sunday nights and also holiday evenings at 7 and 9 o'clock.

Under the direction of the Universal, the New York Theatre presents an enterprising and attractive appearance. The opening on Monday, November 30, was a brilliant one and was a typical Broadway first night. On Monday night, December 7, "Damon and Pythias" had its inaugural presentation at the Fine Arts Theatre, Chicago, which the Universal has taken over for a run of this feature. A brilliant audience attended the premiere.

The Universal Booking offices are very active and getting fine returns from the companies now on tour. The film is meeting with big success in all of its towns and in many cities is being booked for return engagements. On Monday, December 14, "Damon and Pythias" opens for a fortnight at the DeKalb Avenue Theatre, Brooklyn.

All Vitagraph Players on Bill at Once

Thirty-Four Principals and One Hundred and Forty-Two Other Members of Stock Company Shown on Novelty Program

THIRTY-FOUR of the principals and 142 other members of the Vitagraph stock company are represented in the new Vitagraph Theatre, New York City, novelty program which the Broadway Star Feature Company, Inc., is presenting.

The principal novelty is a spoken drama in one act, "What the Moon Saw," written by S. Rankin Drew and presented by Sidney Drew and a company of Vitagraph players in person, including: Sidney Drew, S. Rankin Drew, Jane Morrow, Edwina Robbins, Paul Scardon and J. Herbert Frank. "What the Moon Saw," which is a psychological drama of absorbing interest, is being given at every evening performance and at the Saturday and Sunday matinees only, on account of the players having to be at the studio during the day.

The feature picture part of the program includes a four-part adaptation of Frederick Chapin's comedy play, "C. O. D.," arranged

for the screen by Charles Brown, produced by Tefft Johnson and presented by a notable cast of Vitagraph comedians, among whom will be found: Harry Davenport, Hughie Mack, Charles Brown, Eulalie Jensen, Mabel Kelly, Edwina Robbins, Jack Bulger, William Dunn, William Shea, Ethel Corcoran, Mary Anderson and Charles Edwards.

"C. O. D." comes nearer being the acme of comedy productions than any previous screen story. It is a straight comedy telling a laughable chance encounter of three husbands, who are trying to enjoy a bachelor holiday, and their three wives posing as widows and spending the week-end at a country hotel.

Supplementing the features will be two single reel comedies, "The Athletic Family" and "A Strand of Blond Hair," and a two-part drama, "Sunshine and Shadows," a powerful story of devotion.

AMONG THE EXCHANGES

AROUND OMAHA EXCHANGES

NEBRASKA exhibitors are finding that features pay. More theatres are joining the ranks of those showing features more frequent than ever before and the third feature dealing exchange has been established in Omaha. All three feature exchanges have sprung up there within the last eight months.

E. R. Pearson, formerly manager of the General Film Company, Omaha, and later with the Eclectic exchange here as manager, has accepted the managership of the World Film Corporation at Fifteenth and Harney streets, on the floor above the Hipp theatre.

Omaha now has the World, Warner and Eclectic exchanges. J. E. Kirk, formerly with Mr. Pearson in the service of the General, then road man and assistant with him in the Eclectic, is now manager of the Eclectic exchange there and is making a success of it. Manager Pearson, of the World, declares there has been a remarkable start made by his exchange during the last two weeks. The exchange was opened only two weeks ago.

Manager Frank Harris, of the Empress theatre, Omaha, showing regular service, has switched to features, saying they pay. He says they are practically needed in advertising. Other theatres all over Omaha's territory, including Nebraska, Iowa, Kansas and the Dakotas, are increasing their feature business.

PICTURE PLAYHOUSE OFFICE IN PITTSBURGH

THE Picture Playhouse Film Company, since its organization, has opened new offices on the average of almost two a month, and now has nine branch offices in all the leading cities as far west as Chicago, taking in two branch offices in Canada.

The Pittsburgh office will be at No. 420 Pennsylvania avenue, and the general manager, William J. Lee, has just returned from an extended trip to all of the branches and reports them to be in a flourishing condition.

The exhibitors of Pittsburgh have already demonstrated their co-operation with this new office by sending in a number of advance bookings, and the new branch manager reports a bright outlook for successful business the rest of the winter.

KANE OF WORLD FILM A VISITOR AT CAPITAL EXCHANGE

A. S. KANE, assistant general manager of the World Film Corporation, was a recent visitor to the Washington offices.

MANY MOVIES IN ST. LOUIS EXCHANGE CIRCLES

ST. LOUIS Filmdom has been going through a general move-up and shake-up during the past two months. First, Charles Werner, manager of the American Feature Film Company, in the Navarre building, assumed charge of the World Features offices in place of W. P. Cuff, who went to Springfield, Mo., to become an exhibitor.

Then Ralph Pinkham, manager for Warner's Features, in the Benoist building, resigned, and opened up the new office for Wm. Fox's Box Office Attractions, at 2632 Olive street, and Lou Bent, from the Mutual Exchange, at Fourteenth and Pine streets, joined the box office forces as assistant manager. Next the Alco opened their fine new office at 3630 Olive street. Warner's Features, with Richard Broderick, who came on from Chicago as manager, on the resignation of Mr. Pinkham, packed up and moved out to Film Row, with a fine new suite of offices at 3628 Olive street.

GREATER NEW YORK TAKES LARGER QUARTERS

THE Greater New York Film Exchange, under the management of J. P. Anderson, has moved into larger and more commodious quarters on Ninth street, Washington, D. C. In addition to the program of the General Film Company, this office also handled the Box Office Attractions, which is partially responsible for the present change.

When thoroughly established, the shipping, paper and rental departments will be greatly facilitated by larger space and an increased force. A feature of the exchange, which occupies two large floors, will be an exhibition room for the accommodation of

Later, Ralph Pinkham resigned his managership of the Box Office Attractions, and went back to New York, and his place was taken by Wm. Moore, from the Indianapolis office.

A week later Charles Werner, of the World's Features, quit, to take charge of the Box Office Attractions, and N. F. Robinson, his traveling man, came along as assistant manager. Then August Froebel, for years connected with the St. Louis Motion Picture Company, at Twenty-fifth and Montgomery streets, assumed charge of Warner's Features, and Richard Broderick went to Kansas City to the Warner's office there. Then J. D. Bone moved the Atlas Film Exchange to 3931 Olive street.

And now the news is that the World's Features Corporation has leased a new office in the Polar Wave building, which will bring them and Manager White, who assumed charge when Charles Werner resigned, into Film Row.

exchange men and the press. There will be frequent exhibitions of photoplays before release. There will also be a large committee room, which Mr. Anderson promises to place at the disposal of the local Exhibitors' League, if desired by that organization.

The furnishings are attractive and practical, and if present plans are carried out the Greater New York Film Exchange will possess the most artistic offices in the national capital.

It must not be overlooked that Mr. Anderson has an able assistant in the person of Miss Mary Jeffries.

STANDARD HEADS MAP OUT EXCHANGE SYSTEM

AT a meeting of directors and stockholders of the Standard Film Program, Inc., a California corporation, which will establish exchanges for handling the Standard Polyscope Company program at Denver, Salk Lake City, Portland, Seattle, San Francisco and Los Angeles, held at San Francisco recently, final arrangements were made and officers of the corporation elected.

D. S. Markowitz, who is vice-president of the Standard Program Association, with main offices at 115 Broadway, New York City, will be general manager of this company, with office in Los Angeles, and in addition will be president and general manager of a producing company releasing one two-reel comedy-drama on this program each week, which will be known as the "Empire" brand.

At the present the men back of this new organization have kept their identity concealed, but it is expected announcement will be made within the next week or two in which the locations of the offices, names of managers, and officers of the corporation will be given.

FEATURE DEMAND IN NEW YORK SAYS TAYLOR

GENERAL business conditions are much better throughout the state, according to C. A. Taylor, who is travelling about New York in the interests of the New York Alco Exchange. He believes that a revival of general business activity is not far off. He reports that film demands are steadily increasing, with the demand for features always in the lead.

"Zudora" Makes City Look Like Orient

Players, Dressed in Glittering Trappings of Far East, Astonish Peaceful Inhabitants of New Rochelle in March to Thanouser Studio

PEACEFUL New Rochelle recently saw war refugees pack their prized belongings through its streets. An East Indian caravan, princes, potentates, dancers, horsemen, carrying with them all the panoply, typical of the Oriental's love of display, it was. Down to the Thanouser Park swarmed the mighty army and there a halt was made. The foreigners arrived some time ago from their country where their homes had been pillaged and their villages burned by the now fiercely marauding Turk.

They fled to the coast, bringing with them the swords, guns, rugs, vases, et cetera, which had been prominently placed in their now ruined homes for years, perhaps for centuries; for from father to son, are the family weapons handed down as the smiling daughters of that sun-kissed land receive the laces, the handiwork of their mothers.

Now will they be seen in motion pictures, in "Zudora," Thanouser's photoplay serial which had its first release on November 23. The natives pitched a camp in one of the big buildings at the New Rochelle studio and within the confines of friendly walls, ate and slept in safety, for the first time in many weeks.

The wearing apparel of these natives, genuine in material and workmanship, the wonderful rugs and their crude effects were given a value of \$40,000 by an estimator as the Thanouser management desired and did protect its safety—against fire and thievery by insurance, and in addition placing three watchmen on duty.

In "Zudora" these men and women, garbed in the actual costumes of their war-ridden country, will offer a picture hardly before equalled upon the screen, for the camera, ever accurate, will promptly show the great expense the Thanouser Company is making in order to give this greatest of photoplays a setting in keeping with the genius of its creator, Dr. Daniel Carson Goodman, the superiority of the cast headed by Marguerite Snow, James Cruze, and Harry Benham, and the wonderful stage-craft of the director, Frederic Sullivan, who, by the way, is a nephew of Sir Arthur Sullivan of "Pinafore" and "Mikado" fame.

The set, a throne room scene, one of the largest ever used in a motion picture pro-

duction, is 90 feet long by 40 feet wide. It is such a background that the nimble East Indians will dance and fight, flash their Damascus swords, parade and make merry in order that the motion picture public may be given an accurate representation of their life.

NEW ELBERTON OPENS IN ATLANTA

Special to MOTION PICTURE NEWS

Atlanta, Ga., Dec. 9.

The New Elberton has opened at Elberton, Ga., under the management of A. E. Lange. The New Elberton is located on the site of the old Bonita, which has been built over and remodelled throughout.

Mr. Lange has announced that he will show World and Mutual films to a large extent.

NEW COMMERCIAL COMPANY FORMED IN DETROIT

Special to MOTION PICTURE NEWS

Detroit, Dec. 9.

Commercial films principally will be the specialty of the Atlas Motion Picture Com-

"IMPARTIAL TO ALL"

Motion Picture News, New York City.

Gentlemen: Kindly enter my name on your list of weekly subscribers for the "News." Mr. Braemmer, of the Universal Exchange, Milwaukee, recommended your publication as the "only real movie journal that was impartial to all."

Very truly yours,

F. W. BELLMAN,

417 State Street, Madison, Wis.

pany, of Detroit, Mich., just organized. An office and printing room has been opened at No. 600, Liggett building. Later the company expects to produce one-reel comedy pictures. The officers are: President, C. G. Rose; vice-president, Frank J. Schaffer, and secretary-treasurer, Percy R. Upton. The capital stock of the company is \$20,000, most of which is held by the officers.

LUCKY MISS TRUNNELLE WAS NOT BORN ON FRIDAY

"I'm glad I wasn't born on a Friday," said Mabel Trunnelle, the Edison leading lady, after her narrow escape from serious injury while en route in an automobile to West Hampton Beach a few days ago.

As John H. Collins required the real desert atmosphere for his picture, "The Everlasting Triangle," two automobiles



MABEL TRUNNELLE

were pressed into service to convey his people to the white sands of West Hampton.

While the cars were traveling at a high rate of speed along the Motor Parkway the driver of the car behind discovered that a large bolt from the rear axle of the car in front, in which Mabel Trunnelle was seated, had become loosened and dropped to the roadway.

A warning was shouted and the brakes were applied, while Miss Trunnelle was assisted out. An attempt was made to drive the car to the nearest garage, but only a short distance had been covered at slow speed when the axle broke, the driver escaping injury by holding to the wheel.

COHN SCORES FOOTBALL BEAT

Jack Cohn, editor of the Universal "Animated Weekly," for the third time this season has scored a beat over all other news pictorials in the filming of the Army-Navy football game at Philadelphia.

SOME OF THE CELEBRITIES SHORTLY TO BE SEEN IN ALCO FILM CORPORATION RELEASES



ADELAIDE THURSTON

JANE COWL

MABEL TALIAFERRO

OLGA PETROVA

LINA CAVALIERI

"THE CONSPIRACY"

(Famous Players-Paramount—Four Reels)

REVIEWED BY PETER MILNE

THE Famous Players company has released an unusual number of excellent pictures of late, most all of them adapted from stage successes, and presented by Daniel Frohman. Henry W. Savage has also offered some of them, but "The Conspiracy" is the first picturized play presented by Charles Frohman.

Credit for its success should go largely to Alan Dwan, the director. In practically every point he has shown us that as a director he has no large number of superiors, if any. In adapting the play for the screen, which was originally written by Robert Baker and John Emerson, Mr. Dwan has plainly retained its attractive powers, besides changing it to suit the requirements of the motion picture.

John Emerson himself appears in the principal part, which he created when the story began its life as a play. Although there is quite a long time when he is scarcely in evidence at all, when he does put in an appearance, his characterization of Winthrop Clavering, the eccentric author-detective, is one which will long be remembered.

The man's queer actions, such as dictating into the small hours of the morning to a sleepy stenographer, quitting this pastime



CLAVERING APPREHENDS A MEMBER OF THE SCARLET BAND

with a suddenness that is startling, to perform a few physical exercises, and then in the finale capturing the members of the vice ring with all the melodramatic settings, which he proposes to put into his story, will call for outbursts of appreciative laughter.

Lois Meredith embodies all that one could ask for in the part of Margaret Holt, the sister of a detective who works according to the ridiculed lines laid out for him by Clavering. It is mainly she who brings the vice ring into the law's hands, and the manner in which she accomplishes it, aided by a few other characters, is tense and absorbing as the author-detective's actions are humorous from beginning to end.

Holt, the detective, is played by Francis Byrne, who is really more like a genuine detective than any we have seen for some time. Harold Lockwood, the cub reporter, is breezy and intruding as usual. It would be better if he was called a star reporter instead of cub, however.

Iva Sheperd appears as a member of the corrupt gang, and Hal Clarendon appears to excellent advantage as Morton, the leader of the gang who is stabbed after a furious set-to with Margaret. Dodson Mitchell as Flynn and Edward Durand as Cavelli, complete the cast, which, characteristic of all Famous Players casts, is perfectly well balanced.

Heralds distributed by the company define the picture as a detective comedy-drama, which it truly is. Such a lucky combination is not often achieved. The comedy in it is of the best, as are the dramatic moments, and the detective story links the various phases of the plot even stronger together, so that it is unusually interesting, even more so than just a plain comedy-drama or a detective picture.

"THE SAGE BRUSH GAL"

(Broadway Star Features-Vitagraph—Three Reels)

REVIEWED BY PETER MILNE

IN "The Sage Brush Gal," Rollin Sturgeon has produced a Western picture, containing a story, the like of which we are not often fortunate enough to see. Although not exactly unconventional, it possesses a story-like magnetism, due to which the closest attention is always maintained, even though nothing exceptionally thrilling occurs until toward the end.

The first scene shows the main street of a Western town, the inhabitants of which are only conspicuous for their absence, except for the oldest one, who is seated on a log dreaming of better days. Along comes a touring party. A tire on the car blows out and it has to be fixed. The old man sees an opportunity to unburden his mind of memories of the days in the early 50's and doesn't need much coaxing to go ahead.

Then follows a story just as we would expect an old man who had lived through it and seen it all, to tell it. The story of a girl deserted in the East, the deserter coming West, falling in love with another girl, she finding out the truth and sending him back home, a better man.

Of course, there are other characters, a gambler "on the square," who is also in love with "The Sage Brush Gal" and who finally wins her. There is a bandit, too, who succeeds in leading the boy to stealing. But all ends well for all concerned, except the bandit, who meets death when a mine blast catches him in a small house, which is destroyed.

Of the cast George Kunkel is the ablest in the part of the gambler; he has a sympathetic role which he plays well. Mary Ruby, as the Western girl, is good at times, but if she had rid herself of her smile, natural or forced, whichever it may be, we would admire her work more. William Burke as the scapegrace is fairly good. J. A. McGuire, Myrtle Gonzalez, George Holt, and Dan Duffy complete the cast of the story. Otto Lederer is the old-timer who relates it.

BALBOA ENGAGES HARVEY AS DIRECTOR

HARRY HARVEY, who for twelve years has been successful in the production of photoplays, has been employed by the Balboa Amusement Producing Company, and will have charge of the direction of one of their leading companies. His first feature for this company will be "The Light in a Woman's Eye," from scenario by F. M. Wiltermood, a drama built around an episode in the life of a world-famous eye specialist compelled at a pistol point to perform an operation on a blind woman whom he had jilted in his youth.

Mr. Harvey has a record of having written thirty-seven photoplays, and produced twenty-nine of that number himself. His first work was with the Idoloscope company, in New York, twelve years ago. Since he has been employed by the Mutoscope company, the Edison, Cameraphone, Pathe Freres, Gaumont (in France), Yankee, Solax, Kay Bee, Frontier, Universal and Reliance. He was Pathe's first American leading man and was managing director and superintendent of the Solax plant in New Jersey.

VITAGRAPH PUTS ON ATTRACTIVE BILL

THE Vitagraph theatre offered its patrons, commencing Monday, December 7, a distinct novelty in an original one-act playlet, "What the Moon Saw," by S. Rankin Drew, and presented by a cast headed by Sidney Drew.

"What the Moon Saw" is a psychological drama, written by a Vitagraph player, to be presented by a cast of Vitagraphers, including S. Rankin Drew, Sidney Drew, Jane Morrow, Edwina Robbins, Paul Scardon and J. Herbert Frank, and will have its first performance and only performances at the Vitagraph theatre, under the management of the Vitagraph Company.

DOUGHERTY FINDS WEST ENTHUSIASTIC OVER FEATURES

RUSSELL K. DOUGHERTY, director of the Kinetophote Corporation, was in Boston last week to look over the situation there, and, incidentally, to attend the Exhibitors Ball as a representative of the Kinetophote. Mr. Dougherty had just returned from a trip to Chicago where he visited the new K. C. Booking Company office in the Ballers Building. He said that he found the Western exhibitors very enthusiastic about features.

"THE THIEF"

(Box Office—Five Reels)

REVIEWED BY CLIFFORD H. PANGBURN

WHATEVER the general views of the public may be towards the equality of the sexes the fact remains that when a woman commits a crime she receives much more sympathy than does a man under the same circumstances. In this story it is a woman who is the thief, and in order to protect herself she almost wrecks the life of a man who is willing to shield her. At the last minute her better nature comes to the front, and she saves the man and faces a new start in life.

One of the most noticeable features of the picture is the success which the producers have met with in obtaining a realistic European atmosphere. By the simple use of European telephones, a foreign license number on an automobile and other attention to small but important details the foreign effect is obtained with more success than is at all usual in American made pictures. Another feature which is used rather extensively is that of cross section scenes, so arranged as to show the action in two rooms on opposite sides of a hallway at the same time.

The principal role is played by Dorothy Donnelly, whose ability at handling heavily emotional parts makes her an ideal player for the character of the misguided woman who thought herself forced to steal in order to hold her husband's love. The other principals are Richard Buhler, Harry Spingler and George De Calton.

Marie, the leading character, is in love with a man who at first takes no interest in her. She discovers, however, that he is very fond of handsome gowns, and always is attracted by a well dressed woman.

In order to wear fine dresses she obtains credit at an expensive dressmaking establishment on the strength of being



THE WIFE ADMITS STEALING

residuary legatee of a wealthy uncle. Her plan is successful in that she is soon married to the man she had sought, but she is terrified when she learns that after settling other claims there is no money left for her from her uncle's estate.

She fears that if her husband knows of the large bills she has run up she will lose his affection, and so she steals money from the private funds of a wealthy friend at whose home she is visiting. The step-son of the woman from whom she has been stealing has a foolish infatuation for her, and when she is about to be discovered he takes the blame for the thefts. As he is about to leave home the woman confesses, and all ends well.

DAMON AND PYTHIAS AT NEW YORK THEATRE

MONDAY, November 30, at the New York Theatre, the Universal Film Company will present its newest and biggest photo-play, "Damon and Pythias" in six parts. Two performances daily will be given during the engagement, matinee and evening.

The Supreme Lodge of the Knights of Pythias have endorsed the photo-play not only for its illustration of the order's principles of friendship, but also for its wondrous beauty and dramatic story.

"THE STAR OF GENIUS"

(Pathé—Three Reels)

REVIEWED BY H. S. FULD

A STORY of the stage, its successes and failures, in which the famous French star, Mlle. Napierkowska, is featured, playing the role of the flower girl, Valerie.

The three reels which go to tell the story are replete with action, and special pains taken on the interior settings, all tend toward the recommendation of this offering.

Hurlbert, a composer, adopts a poor flower girl, whom he meets on his way home from an unsuccessful presentation of an opera he has just finished. He finds in her the making of a wonderful dancer and casts her as such in his new opera, which is more suc-



VALERIE'S DANCE THE HIT OF THE OPERA

cessful than his other venture. Some time later, filled with confidence both in his protegee, Valerie, and his new opera, Hurlbert learns of Valerie's love for a former admirer, and that she will not continue with her part in his play.

Heartsick at the loss of the girl whose benefactor he has been, Hurlbert feels the importance of securing her for his new opera, as without her as the dancer the play would prove another failure. How he finally wins her over and the final scenes of the production are masterpieces of acting.

Among the interior settings, rather unusual in that they are truly elaborate, are scenes of the interior of a theatre showing the stage and a large part of the audience, and a stage scene where a cage of wild animals is shown in the distance.

Taken all in all, the picture is one of the best offerings of the month, with clear photography, good acting and a story that holds the observer's interest throughout.

START EXPOSE OF SCENARIO SCHOOLS

LOS ANGELES members of the Photoplay Authors' League are intent upon putting the fake correspondence schools teaching scenario writing out of business, and in a coming issue of their periodical, will give an expose of three schools. The article will give the promises of the schools, their prospectus and results obtained by "students."

One so-called school carries an endorsement from a well known motion picture star who states positively that he never knew of the school until the letter of endorsement was referred to him by the Authors' League. A Brooklyn minister tells what he received for \$27.50. A Honolulu victim gives a recital of his woes. Three managers of schools have been using endorsements which were secured under false pretenses.

UNITED FILM ENTERS FIELD

THE United Film Manufacturing Company is the latest to enter the motion picture field, with offices at 1431-33 Broadway. It is their intention to produce comedy and dramatic photoplays.

Frank P. Donovan, who started the motion picture section of the New York "Star," is with the company, with Percy R. Wernick and Bert Kirkman.

Motion Picture News

HAS THE QUALITY CIRCULATION OF THE TRADE

MOVING PICTURE NEWS EXHIBITORS' TIMES

Published Every Week by

EXHIBITORS' TIMES, Inc.

New York Offices..... 220 West 42nd Street

Chicago Offices..... 223 West Jackson Boulevard

Los Angeles Offices..... 427 South Figueroa Street

WILLIAM A. JOHNSTON.....President
 HENRY F. SEWALL.....Vice-President
 E. KENDALL GILLETT.....Secretary
 H. ASHTON WYCKOFF.....Treasurer
 WENTWORTH TUCKER.....Ass't Treasurer

WILLIAM A. JOHNSTON.....Editor
 LESLEY MASON.....Managing Editor
 WILLIAM RESSMAN ANDREWS.....News Editor
 H. ASHTON WYCKOFF.....Business Manager
 R. M. VANDIVERT.....Advertising Manager
 E. J. HUDSON.....Circulation Manager
 THEODORE S. MEAD.....Chicago Manager
 J. C. JESSEN.....Los Angeles Manager

This publication is owned and published by Exhibitors' Times, incorporated under the laws of the State of New York. The offices and principal place of business are at 220 West 42nd Street, New York City. The address of the officers is the office of the publication.

Entered as Second-Class matter at the New York Post-Office.

Subscription \$2.00 per year, postpaid in the United States, Mexico, Hawaii, Porto Rico and the Philippine Islands. Canada, \$3.00; Foreign \$4.00 per year.

ADVERTISING RATES ON APPLICATION.

Copy for next issue must reach us by Tuesday, 5 p. m.



Cuts and copy are received subject to the approval of the publishers and advertisements are inserted absolutely without condition expressed or implied as to what appears in the text portion of the paper.

Vol. X December 19, 1914. No. 24

Regulating Prices While Raising Them

THE present season marks the end of a year, throughout which MOTION PICTURE NEWS has consistently and persistently urged upon exhibitors the wisdom and profitableness of higher prices of admission.

Other trade publications have followed the example of the NEWS, and become advocates of such a course of action; none, however, with the earnestness or conviction of the NEWS.

* * *

THE campaign has begun to bear fruit. Exhibitors first saw that it was profitable to raise prices—most of them never imagined it would be otherwise—but it was not for some time that they admitted it to be generally possible.

Now, with every exhibitor in the country seriously turning the question over in his own mind, is the time to clear away some misunderstandings, and offer some prudent reminders.

* * *

REMINDER number one is this: the five-cent theatre will never be completely eliminated.

Reminder number two is this: no exhibitor can blindly and arbitrarily raise his prices, without first taking into consideration all the conditions that affect his particular theatre. There are others of equal importance; we will touch upon them presently.

THE question should really be regarded as one of regulation of prices, rather than one of raising prices.

The solution is not the universal adoption of a higher price by exhibitors. It is rather the separation of the five-cent theatres from the ten and fifteen and twenty-five-cent theatres, and the end of the suicidal attempts of the five-cent theatres to compete with the larger and higher-priced houses and with each other by overloading their programs and bankrupting themselves to run one more reel for a nickel than the man across the street.

* * *

THIS maxim may be safely laid down: wherever prices can be successfully raised, they should be raised.

There are too many five-cent theatres. The business has to a great degree emancipated itself from the slavery of the nickel, but it is not yet altogether free.

At the same time, there are towns, or localities in towns, where only a five-cent theatre can live.

The problem is, to take every theatre possible out of the nickel class, and place it where it belongs.

There is not a doubt that from twenty-five to fifty per cent. of the five-cent theatres could successfully raise their prices, if their managers had courage, confidence in themselves and their patrons, and the knowledge of the proper campaign to set in motion for justifying the increase.

* * *

EVERY successful exhibitor knows, or should know, the tastes and the spending powers of his actual and his prospective patrons.

Every exhibitor should be giving his patrons the best he can afford for the price he charges.

The word "afford" is important, because too many are offering the best they can get, regardless of whether they can afford it or not. Usually they can't.

If such an exhibitor is giving the best program he can afford, and he finds a substantial demand for still better pictures, it is safe to assume that his patrons are willing to help him pay the increased cost, to him, of such pictures.

* * *

THE motion picture business at the present time offers one striking contrast.

It is plain that the five-cent theatre is passing, as the representative theatre of the business.

It is equally plain, on the other hand, that there was never such an abundance of good pictures within the reach of the five-cent exhibitor as there is today.

This condition is due almost entirely to the development and multiplication of programs.

It is practically possible, at this moment, for the man who is convinced that his theatre is in a five-cent community and that his existence must be measured by nickels and not dimes or quarters, to offer better pictures, at an expense within his limits, than ever before.

* * *

THEY may not be as elaborate, or as sumptuously staged as the films de luxe exhibited at the great feature theatres of the country. They may be totally devoid of stage celebrities, and unhonored by having their scenarios written by the authors of "best sellers."

But in the basic requirements of a good picture—photography, directorship, action and harmonious setting—without which no star or author can confer success upon any picture, these pictures do, and can be made to compare favorably with the highest-priced films on the market.

For that reason the five-cent exhibitor has no excuse for bankrupting himself to get reasonably good film.

He has no business to be a five-cent exhibitor, if he can escape from it.

But if he lacks either the courage, or the clientele, or both, to enable him to raise his prices, he can at least have the good sense to conduct his business within his means.

IVY CLOSE WINS ENGLISH BEAUTY CONTEST

The most envied girl in England, whose beauty has been universally commented upon, is appearing before American photoplay audiences for the first time.

Ivy Close, the young woman in question, is the star of a five-reel film production, "Lost in London," which has just been released by the United Film Service (Warner's Features, Inc.).

Miss Close was adjudged the prettiest girl in all England recently, when the foremost illustrated newspaper of London, "The Daily Mirror," closed its famous beauty contest.

The contest continued for six months. There were 8,000 entrants. The object of the contest was to discover a woman not only boasting beauty of face, but possessing a perfect figure—in short, a perfect type of English womanhood.



IVY CLOSE

The judges of the contest were among the foremost citizens of England, all members of the Royal Academy. The committee was unanimous in its choice of Miss Close.

DOMAN SUCCEEDS GATES AT UNIVERSAL

R. S. Doman, recently with Philip Mindil, and before that on the staff of the Mutual Film Corporation's house organs, "Reel Life" and "Our Mutual Girl Weekly," has joined Paul Gulick in the Universal Press Department, succeeding Harvey Gates as associate editor of The Universal Weekly.

Doman and "Rufe" Gaynor, son of the late Mayor, conducted *The Evening Sun* motion-picture section two years ago.

MRS. WILCOX MAY BUILD STUDIO

Ella Wheeler Wilcox is contemplating the erection of a motion picture studio on her beautiful estate at Short Beach, Granite Bay, Conn. Her idea is to make it an adjunct to the plant of the Humanology Film Producing Company, at Medford, Mass., which has the exclusive right to produce her famous poems in motion pictures, for release by the United Film Service (Warner's Features, Inc.).

Lubin Burns Down Hotel for "College Widow"

Two and a Half Story Brick Structure of Colonial Design Specially Erected for Star Scene in Ade Comedy

A LARGE throng of spectators in general had an unusually good opportunity recently to see what daring chances motion picture actors and actresses will take when necessity demands, when the



BARRY O'NEIL AND "THE COLLEGE WIDOW" COMPANY (Lubin)

Lubin Company of Philadelphia burned to the ground a two and a half story hotel, and over one hundred performers were rescued from the building.

The fire will be one of the climaxes in

George Ade's famous comedy, "The College Widow," which is now being made by the Lubin Company. Barry O'Neil, who is directing the production, hunted far and wide for a hotel to burn, but couldn't find one, so the Lubin company built one for him. The hotel was complete in practically every detail. It was a 2½-story brick affair of Colonial design and was erected on the big Lubin farm at Betzwood, Pa.

It cost Mr. Lubin several thousand dollars to erect the hotel for the scene. Before setting it on fire gasoline and oil was spread throughout the interior and this made such an intense fire that the entire building was in ruins in ten minutes.

OSBOURNE BACK AT INCEVILLE

George Osbourne, the Inceville director, is about to pack up and return to his duties at the studio of the New York Motion Picture Corporation in Santa Monica after a vacation of two weeks, spent in the northern part of California.

According to letters that have been received from Mr. Osborne, he has been whiling away the time by motoring.

Vitagraph Receipts Given to Xmas Fund

Company Holds Large Benefit on December 9 to Raise Means for Swelling "American" Yule Tide Contributions

THE Vitagraph Company of America, with the liberality characteristic of the three heads of the company—William T. Rock, Albert E. Smith and J. Stuart Blackton—donated to the New York "American's" Christmas Fund the entire receipts of a monster benefit at their Broadway photoplay house, the Vitagraph Theatre, on Wednesday, December 9.

For variety, attractiveness and personal endeavor, its sponsors aimed to have it eclipse any entertainment of a similar character. The special program as arranged by the treasurer of the Vitagraph Company, A. E. Smith, included the personal appearance of the distinguished actor, Sidney Drew, and a company of Vitagraphers, in the powerful one-act psychological drama, "What the Moon Saw," a two-part comedy, "Wild Animals at Large," replete with laughter and thrills, the popular Mezzanotte Trio in song classics, and two of the most popular feature pictures ever thrown upon the screen, "A Million Bid," in five parts, and "Love, Luck and Gasolene," a three-part comedy.

These last two pictures were selected

from among a hundred feature pictures because of thousands of letters requesting a reshewing, from moving picture patrons who were unable to attend the regular performance at the Vitagraph Theatre, where "A Million Bid," registered 250 performances on Broadway and the combined run of the two nearly 400 showings.

All of the prettiest girls of the famous Vitagraph Stock Company, including the stars, were in attendance to offer assistance in the selling of programs.



CATHARINE COUNTISS (Aleo-Life Photo)

"THE TRADE JOURNAL OF NO REGRETS"

Motion Picture News, New York City. Gentlemen: We like the "News" very much, and I am very glad I subscribed to it for a year.

Very truly yours,
L. G. GRIFFITH, Manager,
Vermilion Amusement Co.,
Danville, Ill.

CROWDS THROG NEW YORK BALL

Thousands Brave Bad Weather to Attend the Fifth Annual Entertainment of the Motion Picture Exhibitors Association of Greater New York, Held in the Grand Central Palace, December 7—Prominent Firms Are Box Holders and Numerous Screen Stars on the Floor

EVEN though the weather was of the worst sort, the throng that attended the fifth annual ball given by the Motion Picture Exhibitors' Association of Greater New York on Monday, December 7, could hardly have been larger.

The reception was held on the main and mezzanine floors of the Grand Central Palace, New York City. Owing to the difficulties that were met with last year, when the affair was given in a smaller place, the committee decided on the Palace. The attending persons, who throughout the evening numbered upwards of several thousand, were well taken care of.

So cosmopolitan in nature was the gathering that it is evident that all classes of people are far more than mildly interested in the trade. Prominent exhibitors from New York City and a few more from New York state and other places were on hand in great numbers. The affair accorded them an unusual opportunity to get together and talk business, if they were not too busy meeting and seeing the photo play stars.

As the evening progressed many of the players were introduced to their admirers from a platform. Everyone was welcomed by a rousing reception. Among those introduced were: Clara Kimball Young, Anita Stewart, Earl Williams, King Baggot, Francis X. Bushman, Ben Wilson, Mary Fuller, Rosemary Theby, Kate Price, Edward Earle, Augustus Phillips, Harry Spingler, Irving Cummings, James Cruz, Muriel Ostriche, Marguerite Snow, William Garwood and Nicholas Dunaew.

Dancing was the order of the evening on the main floor, while on the mezzanine three theatres were temporarily installed, in which a great number of the well known companies exhibited their latest and best films. One of these theatres was equipped with a Powers 6-A projection machine, another with a Simplex, while the pictures were projected on a Radium Gold Fibre screen. The third theatre employed a Standard machine, casting the picture on a Moon screen.

Crowds Throng Around Screen Favorites

From the way the crowd roared with laughter at "Tillie's Punctured Romance," the six reel Keystone picture just purchased by Alco, with Marie Dressler, Charles Chaplin and Mabel Normand in the cast, it can easily be seen why the picture received such commendable reviews in the trade papers.

On three sides of the main floor more than a hundred boxes were installed, held by various producing companies, exhibitors, trade concerns and the press. Around the boxes in which were the popular stars of the day great throngs crowded. Mary Pickford, who came in too late to be formally introduced to her many admirers, was the center of a raging mob. Clara Kimball Young and Anita Stewart

were equally heartily received by the crowd.

The box holders of the evening were: The Famous Players Film Company, Alco, Paramount, the Screen Club, Ramo, Kinetophote, All-Star, the World Film Corporation and its subsidiary companies, Vitagraph, Universal, Box Office Attraction Company, Picture Playhouse, Eclectic, Alliance Films' Corporation, Thanouser, Pathé, Mutual, Life-Photo, New York Motion, Crystal, Exclusive Features, Kalem, George Kleine Attractions, Warner's Features, Jesse Laske Feature Play Company, Biograph, Greene's Features, and the Cinema Club.

Committees in Charge

Others were Sam Trigger, the International Exposition Company, E. Elmore, the Precision Machine Company, Eclectic Carbons, H. E. Levy, the New York State Association, the Rudolph Wurlitzer Company, Max Tischler, W. B. Fulmer, William Brandt, I. N. Hartstall. Leading Photoplay exhibitors: Charles Goldreyer, Lee A. Ochs, Haring and Blumenthal, Unger and Buxman, Herman Mayer, the M. and S. Amusement Company, the Nicholas Power Company, the Greater New York Film Rental Company, White's M. P. Enterprises, the Motion Picture Exhibitors' League of America, MOTION PICTURE NEWS, "Moving Picture World," and the "Morning Telegraph."

San Francisco Screen Club Gives Successful Ball

Special to MOTION PICTURE NEWS

San Francisco, Dec. 7.

THE San Francisco Screen Club, organized a short time ago by exhibitors and exchange men in the Exposition City, tendered a grand ball at the Coliseum, Saturday evening, November 28, and scored such a marked success that the event is being hailed as being the greatest of its kind ever held in this city, or on the coast, for that matter. Conservative estimates of the number that gathered in the Coliseum range between 7,000 and 8,000.

The securing of such a remarkable attendance at the ball was made possible by a publicity campaign that easily eclipsed anything of the kind ever seen here. For weeks the publicity committee, of which Joseph Huff was chairman, worked on the details of the press notices and outdoor advertising.

All of the daily papers gave space freely to the event, and for a week preceding the ball, twenty-four sheet posters covered the billboards calling particular attention to the fact that some of the leading actors and actresses in the moving picture business would be present in person, a long list of these being given.

In addition, every theatre ran slides attracting attention to the event; signs were hung in lobbies and thousands of dodgers

Great credit for the successful management of the affair should go to the various committees in charge. Adolph Weiss was chairman of the ball committee; Morris Needle headed the floor committee; I. N. Hartstall recognized everyone and received them well; William Hilkemerer was chairman of the entertainment committee, and Robert Whitten and E. Rosenson supervised the ball and the box committees, respectively.

Members of both the New York State and the national organization were also present, including Marion S. Pearce, the national president, William A. Landau, president of the state organization, and George Wiley, Mark Corey and Peter Jeup.

The grand march, which started slightly before midnight, had considerable difficulty in forming and marching, so great was the crowd that eagerly thronged the lines. It was led by a galaxy of prominent stars who are not often seen together. Mary Pickford and Francis X. Bushman, Anita Stewart and Earl Williams, Clara Kimball Young and Paul Panzer were among the first, and were followed by others of hardly less fame.

After the grand march, a picture of Mary Fuller was offered to the people at ten cents a chance, the proceeds to go to the School Girl's Luncheon Fund. Money was still pouring in at a late hour. The ball was a huge success.

were distributed to patrons of theatres. About a week before the ball banners were hung on all of the cross-wires of the trolley lines on Market street, so that even he who ran might read.

Mayor Rolph and Wife Attend

Although the event was scheduled as an all-night affair, crowds began to flock to the Coliseum shortly after eight o'clock.

Mayor James Rolph, Jr., and Mrs. Rolph arrived shortly after nine o'clock, accompanied by the largest number of city officials ever brought together at a public affair of this character. By the time the music for the grand march began, the building was filled to such an extent that it was impossible to fully clear the floor.

The march was led by Mayor and Mrs. Rolph, followed by the officials of the Screen Club and the moving picture stars who had come to join in the festivities.

In one corner of the hall James Keane, of the Keanograph Company, superintended the taking of a moving picture of the crowd, with some of the prominent player folks in the foreground, while in another section singers from various theatres entertained large audiences.

During the evening Mayor Rolph appeared in the balcony and made a short address, expressing his pleasure at being a

guest of the Screen Club and wishing it a long existence. A number of the moving picture stars were then introduced and all were accorded a great ovation. The Snakeville Trio of the Essanay Company were the first to appear, and their antics, even in evening dress, brought forth a roar of laughter. Then came Ernest Van Pelt, of the Essanay Company; Charles Chaplin, of the Keystone Company; Max Asher, of the Universal; Roscoe Arbuckle, and Mabel Normand, of the Keystone company, and Mrs. Roscoe Arbuckle.

West Coast Studios Represented

The credit for securing the attendance of the players from Los Angeles studios is due to the untiring efforts of a committee appointed for this purpose, with Leon Borjes, of the General Film Company, as chairman. Charles Stillwell, of the Silver Palace, made a special trip to Los Angeles to interview players and studio managers and several other exhibitors worked hard on this proposition while in the Southern city, including Claude Langley and E. B. Johnson, of the Turner & Dahnken Circuit.

The principal committees having the ball in charge were as follows: Hall—F. L. Hudson (chairman), M. Davis, H. Gosliner and B. Abraham. Auditing—R. L. Marks (chairman), Chas. Stillwell, Fred Dahnken and B. K. Herzog. Finance—J. T. Turner (chairman), Leon Borjes and S. L.

Lesser. Publicity—Joe Huff, Tom North, W. McArthur and S. Pincus. Badges—A. Goldberg.

Tickets—B. Quive (chairman), R. L. Marks, W. Citron and A. Markowitz. Printing—Tom North (chairman), F. L. Hudson, I. Lichtenstein and E. Starko. Decorating—R. Abraham (chairman), Bruce Johnson, J. Partington and S. H. Levin. Concessions—E. B. Johnson (chairman), L. Netter, M. Zar, N. K. Herzog and Chas. Stillwell. Program—Charles Stillwell (chairman), Marion Kohn, E. Asher, A. Goldberg, J. Partington.

Handsome Program Distributed

The floor committee consisted of Sid Graham, chairman, with all of the officers of the organization and a number of other members, while fifty-seven members of the club composed the reception committee.

A very handsome program was distributed, and this was much in demand, containing as it did pictures of leading moving picture actors and actresses, together with pictures of the officers of the Screen Club. It was well filled with advertisements of the leading exchanges on the Coast, as well as with those of the leading local moving picture houses. Noticeable among these advertisements were those of the Tivoli Opera House, conducted by Turner & Dahnken, these appearing on every other page throughout the program.

M. L. LANGHART.

FLORENCE NASH HAS HAD VARIED CAREER

Florence Nash, now playing the lead with the Life Photo Film Corporation, is the daughter of the late Philip F. Nash, theatrical man, so it seems only natural that Miss Nash should turn to the stage.

She began her stage career with a short season in stock. Vaudeville has also



FLORENCE NASH.

claimed Miss Nash's attention. She was popular over a wide stretch of country in the sketch "In 1999."

Next Miss Nash returned to the legitimate in "Within the Law."

BABY MORRISON WINS EUGENIC PRIZE

The flying "A" is mighty proud of having a prize baby in its family circle in the small person of little Jack Morrison, the tiny son of Mr. and Mrs. Chick Morrison, who won over all contestants in the recent eugenic exhibition.

Hundreds Turned Away at Boston Function

Special to MOTION PICTURE NEWS

Boston, Dec. 9.

STAIID old "Bawston" came out of its lethargy Wednesday evening, December 2, and in groups of thousands turned out at the Arena to welcome the guests of the New England Exhibitors' Association.

The affair was given unusual eclat by the presence of the Governor of Massachusetts, David I. Walsh, together with several members of his staff, who picked their way through a mass of humanity inside and outside the hall at 11:30 p. m. and took the places assigned to them in the boxes.

It is safe to assume that 10,000 persons found their way into the Arena and 5,000 went home disappointed when the fire department officials closed the door to entrants.

The arrival in the immense building of any particular star was the signal for enthusiastic outbursts and clamoring by the public to get a "close-up" of the moving-picture stars.

Who Was Who at the Function

Mary Pickford, Frances X. Bushman, Edwin August, Paul Panzer, Pearl White, Marguerite Snow, Orrin Johnson, Hal August, Hughie Mack, Gladys Hulette and Claire Young were the principal attractions, while Bert Ennis and Harry Reichbach's dress suits were the principal comedy embellishments.

Louis Selznick, of the World Film, tried to one-step, Hughie Mack occupied the entire floor space for one hesitation, and Governor Walsh, Walter Hoff Seely and Mary Pickford were associated in the presentation of the Pickford and Alco cups.

In addition to those above mentioned, Jesse L. Lasky, Adolph Zukor, Jacob Wilk, C. O. Baumann, Ad. Kessel, Sam Spedon and others made the trip, returning the following day in a special club car.

In charge of the arrangements were the League officers, E. H. Horstmann, president; J. H. Patten and P. F. Lydon, vice-presidents; R. W. Drown, secretary, and G. M. Clark, treasurer. They were assisted by a committee of the following: Samuel Grant, chairman; F. B. Murphy, J. A. Eslow, E. J. Farrell, H. L. Kincaide, J. F. Patten, T. Spry, A. E. Lord, H. F. Campbell, F. J. Howard, C. W. Fraser, W. H. Bradley, H. Asher, H. I. Wasserman, H. A. Sivovlos, J. Laurie, H. Rifkin and S. Levin.

Tickets Sold Out Early

So great was the interest in the motion picture stars that speculators reaped a rich harvest in the early evening. Tickets were bringing far in excess of their face value, and the crowd snapped them up with eagerness. None but ticket holders were admitted after 8:30 p. m.

After the festivities at the Arena the League treated the Stars to a spread at the Georgian. The Copley-Plaza Hotel was made the headquarters for the night, and Thursday afternoon the party returned to New York, sounding high praise for their Boston reception.

MANNING WITH ALL-STAR RENTAL

Frank Manning has become booking manager for the All Star Rental Company, 110 West Fortieth street, New York, and also represents the Mirror Screen Company.

JUST A MOMENT!

Did you get the beautiful six-color portrait of Blanche Sweet that belongs to your copy of "Motion Picture News?"

Look for it as soon as the magazine reaches you. If you don't, someone else will. It's too handsome to be neglected.

THEN WATCH FOR OTHERS OF THE SERIES TO FOLLOW.

"NEWS" SUBSCRIBERS WILL RECEIVE THE COMPLETE SET.

SELIG ATTORNEY DEFINES PRODUCERS' RIGHTS

Nathan Burkan Declares That the First Company to Use a Title in Connection with Any Play so That It Becomes Universally Known to the Public Has Absolute Ownership of the Name and Should Be Protected from Infringement

Special to MOTION PICTURE NEWS

Chicago, Dec. 8.

THE Selig Polyscope Company issues a warning to all exhibitors and exchanges to the effect that all and any persons who exhibit any photoplay bearing the title of "Mizpah" unless the use of same shall have been granted by the Selig Polyscope Company, will be vigorously prosecuted.

Some time ago, the Selig Polyscope Company purchased from Ella Wheeler Wilcox the exclusive motion picture rights to her drama entitled "Mizpah." Another concern has announced a release under the title of "Mizpah." Therefore, the Selig Polyscope Company insists that its rights to the name shall not be infringed upon.

Nathan Burkan, attorney for the Selig Polyscope Company in this matter, expresses the legal status of the case:

"The question of law involved in this matter is as follows:

"One who was the first to use the name 'Mizpah' in connection with a play and has made the name known to the public as the title of his play so that the public has come to connect that title with his play, acquires a right to the exclusive use of that name as the title of the play. He can assert his rights by an injunction suit to restrain another from using the same name as the title of a play or of a photoplay.

Use of Name Only Important

"For the purpose of such an action, it would be immaterial whether any part of the incidents, scenes, characters or ideas of the play have been appropriated. The case would rest upon the question as to whether the use of that name by the infringer is likely to lead the public to believe that the photoplay offered by it is the play to which the title was first applied. The rights would rest on the principle of unfair competition.

"In the case of 'Mizpah' there is no question that the owner of the play 'Mizpah' could stop any concern from using the name as the title of a photoplay.

"Under certain circumstances it has also been held that one who has acquired the exclusive motion picture rights in a play can protect the name against one who uses it for another photoplay."

In view of the frequent duplicating of titles, or the releasing of titles almost similar, this step by the Selig Polyscope Company is a very important one and means a great deal to the manufacturers.

Mr. Selig states that he will protect his rights vigorously without fear or favor against all who shall infringe upon his rights to any titles.

Della Connor, the ex-Pathé star who has just completed her work as Sadie Small in "Officer 666," has been engaged by George Kleine for one of the important parts in his coming play "Stop Thief." Miss Connor will work with Mary Ryan, who is playing the feminine lead of the maid to Harry Mestayer's thief.

Miss Connor is a petite blond and was formerly one of Gus Edwards' proteges. She was lured to the silent stage under protest and spent a year with the Pathé Freres forces in the Jersey hills. Miss Connor thinks that the best work of her career was done under the management of Frank Powell in George Kleine's "Officer 666," which is on the eve of release.

The enthusiastic way in which she speaks of the pleasure she derives from her work, leads one to believe there would be more than a protest if she were asked to leave the studio for the stage once more.

W. D. Cooper, branch manager for George Kleine at Toronto, visited the home offices last week. "Picture conditions are infinitely better in eastern Canada than one would expect," said Mr. Cooper.

"Despite the fact that many lines of industry are paralyzed and that Canada is suffering a heavy draft of men and war materials, picture theatres are well patronized and pay normal prices for all their features.

"Possibly the fact that the streets are full of idle men who, having nothing important to occupy their time, spend spare hours and stray in theatres that would not otherwise be so affected."

Abramson Makes Contract with Samoloff

Star Will Appear in Four Important Features Made by the Ivan Film Productions, Inc., Which Releases "Should a Woman Divorce?"

IVAN ABRAMSON, president and general manager of the Ivan Film Productions, Inc., has entered into a contract with Mr. Samoloff to play the leads in

the quality of his voice that he sent Mr. Samoloff to Milan, Italy, at his own expense, to study under well known Italian masters of vocal instruction with gratifying results to both.

After completing his studies in singing and acting, Mr. Samoloff was engaged as the leading tenor of the opera companies in the principal cities of Italy, France and Switzerland. Six years ago Mr. Abramson engaged him for his opera company which toured the country, to sing the leading parts in "Aida," "Othello," "Faust," "Pagilacci," "Trovatore" and "Gioconda."

Mr. Abramson is well known in theatrical circles as a playwright and director. He recently wrote the scenario of the photo-drama, "Sins of the Parents," featuring Madam Sarah Adler, and proving a "house-jammer." Mr. Abramson has also written the scenario of "Should a Woman Divorce?" based upon one of the vital problems of the day.

"Should a Woman Divorce?" has for one of its principal parts a character which requires for interpretation an artist possessing extraordinary dramatic ability. Mr. Samoloff, having these qualifications, was engaged for this role, and has acquitted himself meritoriously.

In the cast are Lea Leland, Anna Lehr, Mabel Wright, Ordean Stark, Robert Taber, Frederic Roberts and Milton S. Gould.



LEONID SAMOLOFF

four high-class features that his company will release. Eight years ago while Mr. Abramson was the impresario of the Ivan Abramson's Italian grand opera company, whose productions at one dollar were then favorably compared by the critics and the public to high-class five dollar opera, discovered in Mr. Samoloff a powerful dramatic tenor. He was so impressed with

CARTER VISITS EASTERN CITIES FOR THEATRE HINTS

J. R. Carter of Little Rock, Ark., a progressive exhibitor well known in the Southwest, is in New York. He will visit Philadelphia, Buffalo, Baltimore and Washington, looking over the newest theatres.

He is getting ideas for his own house, which is nearing completion.

HE'LL USE IT TO GOOD ADVANTAGE

Motion Picture News, New York City.
Gentlemen: I will use the "News" to a very good advantage. Keep it up.

Very truly yours,

W. C. YUTZY,

Olympic Theatre, Lebanon, Ind.

CALIFORNIA MEMBERSHIP IN SMALL TOWNS

Special to MOTION PICTURE NEWS

San Francisco, Dec. 7.

Practically all of the new members of the California League have come from the smaller towns, there having been no active campaign commenced, as yet, to interest exhibitors in the larger cities, although Los Angeles has been thoroughly canvassed during the stay of State Organizer Cory in the southern part of the state. A prominent exhibitor of Riverside said to Mr. Cory, the organizer: "The fee should be a much larger one. If the league does nothing more than to defeat one bill before the Legislature, I shall feel more than repaid for joining, as it would cost me from \$50 to \$100 to go to Sacramento, and after I got there I could not accomplish much as an individual."

At Long Beach Mr. Cory found business quiet, with an over-abundance of theatres and many exhibitors trying to draw trade through long programs at a small price. At this city he enrolled the Joyland Theatre, the Auditorium, the American and Wigwam, and others promised to join before the first of the year.

HEDWIG LEAVES HARVARD FILM

William K. Hedwig, well and favorably known in the trade, has sold out his interest in the Harvard Film Corporation, and is engaged in preparing a series of productions which will shortly be placed on the market, with headquarters in the Knickerbocker Theatre Building.

During his long term of administration as laboratory superintendent of the Imp and Universal companies, and since then in the office of executive and technical superintendent for the Harvard Film Corporation, Mr. Hedwig has made his capabilities well recognized.

It is reported that Mr. Hedwig is prepared to entertain film propositions of any nature.

CONSTANCE BRINSLEY BACK FROM VACATION

Constance Brinsley, of the eastern scenario staff of the Universal, has recovered from her illness and is now back at work on her new story, "Charity."

JUST A MOMENT!

Did you get the beautiful six-color portrait of Blanche Sweet that belongs to your copy of "Motion Picture News?"

Look for it as soon as the magazine reaches you. If you don't, someone else will. It's too handsome to be neglected.

AND WATCH FOR OTHERS OF THE SERIES TO FOLLOW.

"NEWS" SUBSCRIBERS WILL RECEIVE THE COMPLETE SET.

Important Issues Confront Detroit Exhibitors

Sunday Closing Law, State Censorship, Fire Marshal Bill All Demand Utmost Efforts of the League at December 15 Meeting

Special to MOTION PICTURE NEWS

Detroit, December 8.

THE meeting to be held by the Detroit Motion Picture Exhibitors' League will be the most important in the history of the organization, according to a statement by Peter J. Jeup, president.

"What are the questions to come up?" he was asked by a representative of the MOTION PICTURE NEWS.

"Well," he said, "in the first place, there is the Sunday closing law; we have received assurances that efforts will be made to enact such a law.

"Then there is state censorship. Just how this could be brought about is beyond me, but we have been informed that some members of the legislature favor such a law. Two years ago someone proposed having a state license fee of \$100 for moving picture theatres, and it was defeated, but we are told that this matter is to come up again when the legislature convenes after the New Year.

"Then there is the State Fire Marshal bill. Twice a year, we must be inspected by the State Department, the fee being \$10

each time, making a total cost to us of \$20. This is absolutely unnecessary, once a year being entirely sufficient. Moving picture theatres now have three departments making inspections: 1, the local fire authorities; 2, the public lighting commission who inspect the electric wiring, and the building inspector.

"On top of this we have two inspections from the State Fire Marshal, which, as I said before, are entirely unnecessary and only make us spend \$20 'for nothing,' as it were."

Mr. Jeup attended the meeting in New York of the executive committee of the National Association, held on Monday, December 7.

The Detroit association reports good results with its requirement that theatres give only three reels of pictures for five cents, and five reels for ten cents. In a number of instances this understanding has been violated, but the matter was referred to the film exchanges, who are giving their support and co-operation to the association in helping to eliminate this evil of the business. A. R. THORNBURG.

Milwaukee Exhibitors Hold Meeting on Posters

Association at Session, from Which Everybody Is Excluded Not a Member, Considers Stringent Poster Ordinance

Special to MOTION PICTURE NEWS

Milwaukee, Dec. 8.

AT a meeting held behind closed doors at the club rooms of the Plankinton House and from which all press representatives were barred, the Milwaukee Motion Picture Exhibitors Association took action on a letter sent out from the city attorney's office in which the exhibitors' attention was called to sections 1051-1052 of the city ordinances which provide that:

"The posting, exhibiting or displaying so as to be exposed to view from any public street, alleyway, public way, or public grounds, of pictorial prints, pictures or paintings, or of bills, posters advertising matter or words of any kind, that exhibit or portray the nude human form, or parts thereof, between the shoulders and the knees, or that so portray the human form whether nude or not, as to be suggestive of lewdness or obscenity, or that contain words, letters or characters which convey a lewd or obscene idea or that portray murderous or criminal personal actions, encounters or assaults, shall be unlawful." Section 1052 "provides a penalty for any person, firm or corporation, or any officer of any corporation, who shall violate or cause to be violated any of the provisions of section 1051 of a fine of not less than \$5 nor more than \$200."

In his letter Assistant City Attorney Bartell, who is handling the matter, stated that "many exhibitors are trying to evade this ordinance by pasting or sticking a piece of paper over the revolver, gun or knife. That does not make such posters legal. It merely emphasizes the weapons which are in the hands of the parties, and will therefore not be in any way a defense

in a prosecution under this ordinance. We therefore kindly request that you stop using such posters at once."

At a previous meeting a committee was appointed to wait on Attorney Bartell, and they assured him that the exhibitors had no intention of violating the law and were anxious to cooperate with his office in the matter. Two months' time was given them to eliminate these objectional posters.

NOT AUTHORIZED TO BOOK "CALLED TO THE FRONT"

The Jacobs Film Company, Manhattan building, Milwaukee, Wis., which is booking the Apex releases in Wisconsin for the Casino Feature Film Company of Detroit, requests Wisconsin exhibitors to notify them immediately of any person or persons seeking to book the three-reel Apex feature, "Called to the Front."

It has come to the notice of the company that certain people are booking this picture without authority. W. A. Baier, manager of the Jacobs Film Company, states that any person or persons found booking this picture in the State of Wisconsin without authority will be prosecuted.

ON ROAD FOR KINETOPHOTE

"Big Ben" Abrams, well known throughout the United States as a successful film salesman, is in the West procuring contracts with western exchanges to handle the booking of pictures from the K. C. Booking Company, Incorporated, the concern which looks after all the pictures produced or controlled by the Kinetophote Corporation.

Ruth Roland Goes to Balboa for Three Years

Famous "Kalem Girl" Joins West Coast Producing Company at Salary of \$1,000 a Week, Following Henry B. Walthall—Several Other Stars Will Be Added to the Aggregation in Pursuance of the Company's Policy to Live Up to Their Standard, "Pictures Beautiful" in Catering to Exhibitors

RUTH ROLAND, esteemed by millions of theatre-goers throughout the world as "The Kalem Girl," has signed a three-year contract with the Balboa Amusement Producing Company, of Long Beach, Calif., and will be the star leading woman of one of the corporation's dramatic companies, her engagement following closely upon that made with Henry B. Walthall, known as "the world's greatest moving picture actor," who recently joined the Balboa corporation at a salary of \$1,000 a week.

Several other famous stars are soon to be enrolled with the Balboa's aggregation of players. The company is doubling its studio equipment, erecting buildings, purchasing large supplies of costumes and scenic accessories and expending many thousands of dollars in a vast campaign of business expansion, these improvements becoming imperative as a result of the highly remarkable success of Balboa feature films during the last twelve months, which triumphs caused a pressing demand from exhibitors everywhere for larger supplies of "the pictures beautiful."

The Messrs. H. M. and E. D. Horkheimer, owners of the Balboa studios, are therefore striving energetically to cope with the insistent calls of theatre proprietors for the big feature releases.

First Famous in "Cinderella"

Miss Roland was born in San Francisco, August 21, 1893. At the age of four years she made her theatrical debut by appearing as the mascot in "Cinderella," in a song and dance specialty, thereby winning fame as "California's wonder child." Later she enacted child's parts with the Ed Holden Stock Company.

She then was in vaudeville for a time with the Broadway Trio, the organization making an extended tour of the Eastern cities. Finally, after returning to San Francisco, Miss Roland was featured in Morosco and Belasco productions as a child actress, enacting roles in "Uncle Tom's Cabin," "The Ensign," "Bootle's Baby," and other plays. She next had two years' work in the Orpheum circuit, being featured as "Baby Ruth," following which her mother took her to Honolulu, where she appeared at the leading theatre and, during her six months' engagement, became the favorite of the surviving members of the royal Hawaiian family, once headed by King Kalakau. She received many handsome presents from Prince David and the other Hawaiian nobles.

After returning to California, she enacted for many months the star role of "Little Lord Fauntleroy." She then played a season in vaudeville and, as she was still a child, attended school in Los Angeles until she was 16 years of age. After leaving school she enacted important roles in a stock company, worked for a time in vaudeville and then joined the Kalem moving picture company's players, where she has remained four years and has won

world-wide fame as "The Kalem Girl." During her first fourteen months with the Kalem forces she enacted the part of the heroine in scores of Western and Indian-military dramas, among these films being



RUTH ROLAND

"The Chance Shot," "Round-Up at Dawn," "In Peril of Their Lives," "The Indian Maid's Sacrifice," "Biel's Flute," "The Sheep Man's Triumph," etc., etc.

Later she was starred in some big Kalem comedies, including "The Pasadena Peach," "Ruth's Hat," "Hypnotic Nell," "When Women Are Police," "Romance of a Dry Town," "The Slavery of Foxius," "Elopement in Rome" and hundreds of other comedies. One of Miss Roland's big comedy-drama successes was her star characterization in "Wanted, an Heir," which film was released lately. The "Ruth Roland, Detective" series of releases also proved a great success.

Starred in Kalem Comedies

In "The Kalem Girl," a feature film written especially for her, she displayed all the athletic prowess required of a moving picture heroine. She gave a wonderful exhibition of riding, swimming and fencing.

Several months ago Miss Roland enacted the leading role in a big series of Kalem dramas written especially for her and entitled "The Escapades of Ruth." During this work she won great commendation for her first class portrayal of highly dramatic roles and proved herself to be in every way one of the world's most versatile actresses, both in comedy characterizations and in parts requiring the most tragic emotions.

Miss Roland's engagement with the Balboa company is, in a way, a return by her to her work as a dramatic player, for it was in serious roles that she first achieved success as a cinema actress.

Her youth, beauty, genius, talents and long experience as a star in the cinematographic art will all contribute to her forthcoming triumphs as a featured player for the Balboa films.

Neglect of Federal War Tax Means Heavy Fine

Exhibitors Will Be Mulcted Fifty Per Cent. if They Do Not Pay War Revenue Promptly—Exact Date Not Yet Settled

A FINE of 50 per cent. will be levied upon all exhibitors who have not paid their theatre war tax.

This penalty for negligence is provided in the bill as it was passed. It was agreed, however, owing to the short time intervening between the actual date on which the bill became a law, and the date for the payment of the tax in Washington, that a stay of "a reasonable length of time" would be granted.

Whether "a reasonable length of time" may be determined as a week, or two weeks, or a month is unknown. It is generally believed among Washington officials and attorneys having to do with the theatre tax, that the extension was designed to be limited to two weeks as a maximum. This makes the tax returnable, at the latest, by December 15. Others say that December 8 is the last day.

Enforcement of the penalty will serve to materially increase the exhibitors' burden.

The tax, although figured on a basis of one year, is levied for an actual period of

eight months, beginning November 1, 1914, and ending July 1, 1915. Remittances should be made for this period.

Exhibitors with theatres of three hundred seats capacity, or less, assessed at \$25 a year, will send in but \$16.67, the tax for eight months. Failure to pay this immediately means that the fifty per cent. penalty would bring the total to the same sum which would have to be paid for one year's tax.

**BE SURE YOUR RELEASE DATES
ARE RIGHT—THEN GO AHEAD**

**YOU CAN ALWAYS BE SURE THEY ARE
RIGHT IF YOU GET**

MOTION PICTURE NEWS

Five pages of every issue are devoted to nothing but release dates—the most complete and correct to be found anywhere. Comparison has proved it.



A SCENE ON THE FILM GRIDIRON



KRITERION PUTS ONE OVER

M. F. O'K
W.P.T.

MICA'S "ALL-AMERICAN" SELECTION

NAME	POSITION	COLLEGE
Monarch	Left End	Comedy
Santa Barbara	Left Tackle	Drama
Alhambra	Left Guard	Comedy
Thistle	Centre	Comedy
Alhambra	Right Guard	Drama
Santa Barbara	Right Tackle	Comedy
Navajo	Right End	Drama
Nolege (Capt.)	Quarter Back	Sci. & Educ.
Paragon	Left Half Back	Drama
Trump	Right Half Back	Drama
Punch	Full Back	Comedy
Reserve	"Kriterion Star Subject," of "Kriterion College"	
Manager	"Mica Film Corporation"	
Head Coach	B. E. Clements	
Asst. Coaches	"Our Exchanges"	



(Continued on the next page.)





By "MICA"

In making my "All-American" selection, I have tried to be impartial as to sectional prejudice. I have scoured both East and West for my material and have picked the best for their respective positions. The public in general will admit that the two colleges that have the best teams are "Comedy" and "Drama" and I, therefore, had to select several of the best from each of these colleges. Although "Scientific & Educational" college is small, I could not leave "Nolege" out. The same applies to "Kriterion Star Subject" of "Kriterion" college as I will show you in the following:—

The Line

In choosing my ends, I could not overlook "Monarch" and "Navajo." Their ability to get right down the field and nail their people assured them of their places.

The tackles are the "Santa Barbara" brothers whose head work in figuring out what the opposition was doing and then stopping the play before it was started are peers in their respective positions.

For my guards, I also chose brothers in the "Alhambras." Their steadfastness and firmness in resisting attacks place them as bulwarks.

An "All-American" team needs in a centre position one who blossoms forth at all times. Thistle is this very man.

The Backfield

In a Captain, the team needs a general and I believe I have made no mistake in choosing "Nolege" who has the scientific rudiments, together with three seasons of educational work in the game.

For perfection in circling the ends, either "Trump" or "Paragon" are fast, but this is not their best asset. When this team would have to make large gains, the manager would be able to count on his "Trump" or "Paragon" to receive the forward pass from my full back, "Punch," to make the required gain. For strength in bucking the line, "Punch" sets the pace. He sure hits it with a vim that is unequalled by any other.

For my reserve, I choose "Kriterion Star Subject." I put him in this position because my other men are strong enough to hold any opposition during the week, and when the big games come along at the end of each week this man could certainly be counted on to win the feature.

Management

"Mica Film Corporation," by its organization and its giant strides, is too well known in the field to select any other and is perfectly capable of handling this sterling line of material.

Head Coach

Who other than B. E. Clements could I choose? He has proven by his past performances each year to be in a class by himself.

Assistant Coaches

I choose "Our Exchanges" to assist my head coach. Their years of high standing in the game place them on my staff without doubt. They are known and recognized to be the ones that instil respect into all who come in contact with them.

Honorable Mention

for

the "All-American"

- | | | |
|-------------------|-------------------|-----------------|
| "Bob" Daly | Frank Montgomery | Crauford Kent |
| "Bert" Angeles | Charles K. French | Lee Hill |
| Donald MacDonald | John Dillon | "Bud" Rose |
| Fritzi Brunette | Edw. Alexander | Wm. E. Parsons |
| Dorothy Davenport | Wallace MacDonald | J. L. Phipps |
| Mary Ruby | Jack Prescott | Allen Fralick |
| Mona Darkfeather | Harry Fisher | Eva Lewis |
| Lucille Young | Sidney DeGray | Harry Davenport |
| Rena Rogers | Benj. Horning | Chester Whitey |

I also wish to mention "Exhibitors" of "Theatre" college who have shown great promise this season, and trust I may get in more personal touch with them so as to get a better line on them. I predict you will see them on my selection next season.

All of my "All-American" selections and my "Honorable Mention" have passed the stage of inexperience by their previous work in the last five years and are without a doubt able to cope with this—

The Best Team in the Country

Individual Pictures of this team will be shown in the best theatres throughout the United States.

Reserve NOW at our Exchanges in any of the following cities:

- | | | | |
|--------------|-------------|---------------|------------------|
| NEW YORK | DALLAS | CLEVELAND | LOS ANGELES |
| PHILADELPHIA | ATLANTA | CINCINNATI | SEATTLE |
| BOSTON | CHICAGO | INDIANAPOLIS | DENVER |
| PITTSBURG | ST. LOUIS | KANSAS CITY | MINNEAPOLIS |
| BUFFALO | DETROIT | SAN FRANCISCO | MONTREAL |
| | | | WINNIPEG |
| BALTIMORE | WILKESBARRE | EVANSVILLE | LOUISVILLE |
| NEWARK | COLUMBUS | SPRINGFIELD | WICHITA |
| SYRACUSE | CHARLESTOWN | DES MOINES | OMAHA |
| ALBANY | FT. WAYNE | NEW ORLEANS | SALT LAKE CITY |
| | | | PHOENIX |
| | | | PORTLAND |
| | | | VANCOUVER, B. C. |
| | | | TORONTO |
| | | | ST. JOHNS |

or

MICA FILM CORPORATION

Sixth Floor

1600 BROADWAY

NEW YORK CITY



(Copyrighted.)



FILMS AID WORK OF SAGE FOUNDATION

MOTION pictures are now a recognized mode for the propagation of the work of the Russell Sage Foundation in its building at 130 East Twenty-second street. A complete projection outfit and a Radium Gold Fibre screen have been installed in the lecture rooms by Louis Kalvin, electrical engineer in the Atsco department of the Alco Film Corporation.

The machine and its accessories are on a movable platform so that they may be wheeled from one room to another. The screen is so set up that it can be taken down and installed in a second lecture room within three minutes.

This apparatus is primarily intended for the gathering of the workers associated with the Foundation in its welfare work. Several scenarios have been written by officials of the Sage organization which aim to illustrate points of human betterment sought by the Foundation.

Each of these scenarios has been manufactured by a producing organization and each presents an argument in story fashion. One deals with the need of sane and safe Fourths of July, and another with recreation centers.

MILWAUKEE OPERATORS GIVE A GALA PARTY

THE Thanksgiving party given by the Motion Picture Operators' Union No. 164 at Freie Gemeinde Hall, Milwaukee, Wis., Wednesday evening, November 25, was a most successful affair. Two hundred operators, their wives, sweethearts and friends



AFTER THE BALL OF THE MILWAUKEE OPERATORS

crowded the hall and enjoyed themselves hugely. Sandwiches and refreshments were provided the guests. A five-piece orchestra under the direction of Glenn R. Crum provided the dance music.

HOLDS SECOND EDISON NIGHT IN BRONX

MANAGER BALSDON, of the Dyckman Theatre, at 207th street and Broadway, New York, was so pleased with the success of an "Edison Night," held recently at his other theatre, the Regent, that he repeated it at the Dyckman, December 1.

Despite the inclement weather, the faithful fans were there in such numbers that before 9 o'clock the doors had to be closed. The program was exclusively Edison, featuring Augustus Phillips in the "Midnight Ride of Paul Revere"; also shown were: "Bootle's Baby," "The Everlasting Triangle" and "Two's Company."

When the stars who appeared in the films were introduced from the stage they were given an ovation, the girls of the party each receiving a huge bouquet. Manager Horace G. Plimpton occupied a box with the Edison players: Viola Dana, Gladys Hulette, Mabel Trunnelle, Robert Connes, Herbert Prior and Augustus Phillips. Manager Balsdon tendered the party a banquet at the Hotel Cecil after the performance.

TISDALE NOT WITH INDUSTRIAL MOVING PICTURE

S. R. WARE, manager of the Dixie theatre, Sparta, Tenn., declares that a F. M. Tisdale is traveling through Tennessee taking local moving pictures and is using the name of the Industrial Moving Picture Company. The company states that F. M. Tisdale is not and never has been connected with the company, and is using its name without authority.

"THE STOLEN BIRTHRIGHT"

(Pathé—Three Reels)

REVIEWED BY CLIFFORD H. PANGBURN

THE attractive scenes which abound in the vicinity of the Wharton studios at Ithaca, where this picture was made, have been used in a way which adds much to the beauty of the production as a whole. The open farm country and rolling hills which surround Cayuga Lake make backgrounds of unusual charm, and the effect has been heightened by the careful toning of the film to warm shades of brown and green.

Near the close of the picture there is a particularly fine series of double exposures. These show the two principal male characters hurrying to their homes. One is rushing west and the other east. The two are shown boarding different trains, and the trains are seen on their respective tracks in this series of double exposures. As a climax to this photographic effect the two men are seen on opposite sides of the screen, one clasping his wife and the other his sweetheart in his arms.

There are a number of clever effects, such as the scene in which the hero draws a caricature of himself and his sweetheart, using the end of an old log as his drawing surface. The principal parts are played by Wharton favorites. Elsie Esmond is seen in the dual role of the twin sisters, who grow up far apart. Others are Thurlow Bergen, Harry Carr and Frank Brownlee.

A heartless landlord seeks to evict a poor farmer tenant just after his wife has given birth to a daughter. The farmer holds the sheriff off for awhile, but during the trouble his baby dies. By a strange chance he gets a chance to substitute the dead baby for one of the landlord's.

The farmer then moves to Phoenix, Arizona, his wife supposing the baby to be hers. Twenty years later the daughter, who has been left in her rightful home finds herself an orphan and goes to a city to work as a stenographer. She marries a man who knows nothing of her past. She is mistaken, for her sister is recognized by a man who knows the supposedly dead girl, and a strange set of complications follow, which all go to make a story which holds the interest closely. The two sisters eventually discover each other, and all ends happily.

CASINO THEATRES WILL HAVE PUBLICITY ORGANIZATION OF THEIR OWN

THE Casino Amusement Company, of Detroit, controlling a chain of nine theatres, will hereafter have its own publicity director and will also issue a weekly publication devoted to its theatres which will be distributed to the patrons. The person to handle this new department will be Howard O. Pierce, who has been in charge of the Washington Theatre since it opened, previous to which time he was manager of the Liberty Theatre.

Mr. Pierce has already assumed his new position and expects to have the first issue of the new publication, to be known as the "Weekly Film News," ready the latter part of December. It will be eight by nine inches, and contain sixteen pages. The attractions at the various theatres will be contained therein, there will be general news items relating to the moving picture industry, illustrations and photographs, and a few pages devoted to advertising. The weekly distribution will be about 50,000 copies. It will be the first publication of its kind in the city.

Other changes announced by the Casino company are: H. W. Irons as successor to Howard Pierce, as manager of the Washington; Mr. Irons for the past few weeks has been handling affairs at the Liberty, succeeding T. D. Moule, who went to the new Alhambra. The transfer of Mr. Irons to the Washington has resulted in the appointment of Harlan W. Starr as manager of the Liberty. Mr. Starr has been associated with A. J. Gillingham, of Detroit, for seven years, for the past four years managing the New Empire.

PRESS CLUB SEES BATTLE FIELD FILMS

Special to MOTION PICTURE NEWS

Washington, D. C., Dec. 9.

THE National Press Club was highly entertained by an exhibition of motion pictures taken on the Belgian battlefield by the daring operator, Edward Weigle. The pictures are on their way to London for exhibition. There were 5,000 feet of film.

Aside from the members of the Press Club, there were also present many national and local officials.

"GOADED JEALOUSY"

(Santa Barbara-Kriterion—Two Reels)

REVIEWED BY PETER MILNE

ALTHOUGH this picture contains a plot which seems rather exaggerated, that of a husband's foolish jealousy of his wife, it is played in a really capable manner by the cast. Motion picture characters are known as the most jealous species of humanity, so if their affliction sometimes seems unwonted, we have come to the point where allowances have to be made.

"Goaded Jealousy" among its class of pictures is certainly one of the best. It is melodrama, and melodrama of the highest sort, played as convincingly as possible by the leading players, and obviously carefully directed.

Fritzi Brunette has been awarded the part of the wife of the story, who because her husband is insanely jealous of her suffers considerably. Edward Alexander has quite an emotional role as the husband, and plays it with force. The friend of the family is John Prescott. Jack Dillon, one time of the Griffith forces, is the gardner. The picture was produced by William Robert Daly.

Photographically and scenically the picture leaves little room for improvement. There is one inconsistency in the picture which stands a fair show of being noticed by the unobserving. When the husband walks out of one scene clothed in a dark suit and into another garbed in a light one, people may question his rapid change abilities. This small discrepancy comes far from marring the whole production, and it is practically the only avoidable error that has crept in it.

The story is well built, and its situations, which are well developed by the players and the director, keep one in continual suspense. The husband's jealousy, aroused by the innocent actions of his friend, are about calmed when he reads a telegram from his wife's brother to her signed by Jack, which is the name of his friend. The husband has never heard of his brother-in-law and naturally or unnaturally is enraged, but things end happily.

One pleasing thing about the picture is that even though a melodrama, it lacks one melodramatic convention, that is the ruthless villain. There is no villain in the play of any account at all. A thing like this will be noticed, and no doubt appreciated, as will the whole picture.

"THE BELOVED ADVENTURER"

(Lubin—Fourteenth Episode)

IN this picture Lady Betty plays a very conspicuous part and shows her Western training by the expert use of the lariat on horseback. A nephew of the good Lord Cecil returns from India, being entrusted with a priceless diamond to be delivered to the King of England, to express the future loyalty of a conquered prince.



TALKING IT OVER

The jewel is stolen by the gang of conspirators of which the Countess Lurovich is the chief. Betty lassoes the thief, and the peasants of Croftlough drive the conspirators to the edge of a cliff, which collapses, carrying them to death.

This is the fourteenth chapter of the series. There is one more to come.

"THE BATTLE OF LOVE"

(Essanay—Three Reels)

REVIEWED BY T. S. MEAD.

MR. WILSON WOODROW is the author of the fourth prize mystery play produced in conjunction with "The Ladies' World" for release on December 19. A triangular love-story is at the base of the plot, but it is treated in an exceptionally wholesome manner; unusual situations and clean action rather than sordidness being relied upon to hold the interest for three reels.

The part of Arthur Chandler, a wealthy young clubman, is well suited to the rare ability which has made Francis H. Bushman so popular in roles of this kind. Ruth Stonehouse, as Bessie Wells, is charmingly spontaneous and natural. The principals are supported by the excellent cast of Rapley Holmes as John Wells, and Thomas Commerford as Ezra Chandler, Lillian Drew as Vivian La Mar, Harry Dunkinson as Jack Fixit, Helen Dunbar and Leo White.



THE DISCOVERY.

To the delight of their parents, Arthur Chandler and Bessie Wells become engaged and are most devoted until an actress enters upon the scene. Bessie Wells' jealousy is aroused and she breaks the engagement. Jack Fixit makes a wager with two fathers who are much upset by the incident that he can still bring about the marriage within twenty-four hours.

He obtains the aid of Vivian La Mar, the actress, who agrees to help in the plot. She takes Chandler for an automobile ride and, after inducing him to get out of the car, leaves him stranded in the country. Miss Wells is then notified that the actress has been murdered, Chandler being the one upon whom suspicion has fallen. She immediately locates Chandler, who, of course, denies the charge, but the two families, knowing the plot, refuse to hear his explanation. Miss Wells stands by him, and upon the advice of Fixit they decide to board the Chandler yacht, be quickly married and escape until things blow over. On the yacht they find their relatives and friends all assembled. The couple take it in good part and a novel wedding ceremony is celebrated.

ALBUQUERQUE ELECTS NEW OFFICERS

Special to MOTION PICTURE NEWS

Los Angeles, Dec. 7.

AT a meeting of the directors of the Albuquerque Film Manufacturing Company, a new Mexico corporation, capitalized at \$50,000 with \$28,000 paid up, held the first of last week, a change was made in the personnel of the board and the officers by the sale of stock held by William E. Rogers, who was secretary and treasurer, to Thomas B. Leddy, a prominent Los Angeles attorney.

H. F. Connelly, who has served as vice-president, resigned from that office and was elected secretary and treasurer, and Mr. Leddy was elected vice-president. Gilbert P. Hamilton remains as president and general manager of the company, and is also vice-president of The United Motion Picture Producers, Inc. The Albuquerque company is now making one reel of comedy drama featuring Dot Farley and one reel of farce comedy each week, for the United Film Service program, successor of Warner's Features.

"THE LURE OF THE WINDIGO"

(Selig—Two Reels)

REVIEWED BY T. S. MEAD

THE North Woods, with its vastness, its wholesomeness and its vigor, furnish particularly charming settings for a picture. In this one the scenes of the trapper's home, the Indian cabin, the frontier settlements, the lumber camp, the forests and the rivers are worthy of special praise. They, together with the excellent costumes and the remarkably fine acting of every member of the cast, make this production most realistic, interesting and thoroughly worth-while.

Edith Johnson as Annette Le Clerq, the beautiful daughter of the old trapper Hugo Le Clerq, played by Lafayette McKee; Barney Furey as Gerard McChesney, the sergeant of the Northwestern Mounted Police; Lamar Johnstone as Kiawa, a Cree Indian, render the principle roles very cleverly. Almost equally good are the rest of the cast, which includes Charles Wheelock as Jaques Le Bree, the honest lover of Annette; Frank Mayo as Louis Le Clerq, her brother; Lillian Hayward as Mrs. Le Clerq, her mother; Lucile Joy as Minna, the Indian squaw of Kiawa.

The story, though it deals with the time-worn subject of the betrayal of innocent love and the unwritten law, is nevertheless so well developed by the use of entirely original ideas that it is far removed from any criticism of being hackneyed. Gerard McChesney a young sergeant of the Northwest Mounted Police, wins the love of pretty Annette away from her long devoted suitor, Jacques Le Bree. McChesney turns out to be dissolute and without any moral sense. He grossly betrays the confidence bestowed upon him by Annette and her family and breaks his promise of soon returning to make her his wife.

In her wanderings, after she and her unwelcome baby have been turned out of her father's house, Annette runs upon Kiawa, her old Indian friend, whose undying hate had previously been aroused against McChesney. To avenge himself he decides to lead Annette and her child to McChesney, who he knows is at the settlement, and to confront with the prof



KIAWA BEFRIENDS ANNETTE

of his dishonorable act. He imitates the sighing of the wind through the trees and thus lures Annette, who believes in the old Cree superstition of the voice of the Windigo, mile after mile through the forests.

At the settlement, McChesney is forced to marry Annette. The simple ceremony completed, her brother demands satisfaction and chokes McChesney in the fight that follows. Thus right triumphs and to Annette is eventually restored the true love of the forgiving Jacques.

LOS ANGELES CENSORS REORGANIZE

THE Los Angeles Board of Censorship has been reorganized with the following permanent officers: A. P. Tugwell, who is president of the Exhibitors' League and owner of a big motion picture theatre at Jefferson street and Central avenue, is president; E. T. Jorgensen, secretary, and Elbert Deffebach, vice-president. Mrs. Elizabeth S. Hutchins has been appointed to the board.

"THE GHOST BREAKER"

(Lasky-Paramount—Five Reels)

REVIEWED BY PETER MILNE.

THERE can be hardly a cause for doubting the success of "The Ghost Breaker." Such a long and successful run as the play had on the stage would be almost sure to pack the house in which the picture was shown, even if it had nothing else to favorably commend it, aside from its sensational triumph in another form.

But the happy part of the proposition is that there is a great deal else to praise aside from the above mentioned fact. To begin with, the picture, retains the same star as the legitimate play, H. B. Warner. In the role of Warren Jarvis, the part which he carried so easily and successfully on the stage, Mr. Warner is seen at his best.

Again, there is hardly a play which has adapted itself, or rather that has been adapted for screen use, that is better suited for this purpose. Starting as a drama, the picture continues as such until the end of the second reel, when Jarvis enters, and thereafter the



JARVIS ESCAPES VIA THE TRUNK LINE

comedy starts, varied here and there with more touches of the dramatic.

The scenes in which Jarvis and his colored servant, Rusty, a character played faultlessly by J. W. Burton, explore the treacherous rooms of the haunted castle, while mainly humorous, are both exciting and fearful. They are so well built and worked out that while this part of the picture is on the screen, the interest is kept at the greatest conceivable height.

There may be some slight difficulty in placing the numerous characters that are introduced in the first reel. Most of them play such small parts, however, that when the principals enter their places are clearly apparent or forgotten.

Others that appear in the cast are Rita Stanwood in the role of the distressed Princess Maria Theresa, the girl that Jarvis takes as his wife after he has solved the mystery of her hidden jewels and penetrated the black cloud which was forever hovering about herself and the other members of her family. The villain of the play, Duke D'Alva, is played well by Horace B. Carpenter. Billy Elmer, Dick La Strange and Fred Montague are cast in the roles of his hirelings. The princess' brother is carried off by Jode Mulally. Theodore Roberts as his father, is killed before many feet have passed and has little opportunity to display his talents.

It will be remarkable indeed if "The Ghost Breaker" does not meet with success. It has an admirable plot, combined with excellent acting and superior direction; and again it has the country-wide reputation that the play created for it.

KENTUCKY EXHIBITORS TO HOLD CONVENTION

THE Motion Picture Exhibitors' League of Kentucky is planning to hold a meeting soon to discuss various topics pertaining to the business and of importance to exhibitors. It is probable that the convention will be held the latter part of December at either Louisville or Lexington, but no date has been definitely set.



A FEW OF THE "HIGH-LIGHT" SCENES FROM "THE LAST EGYPTIAN," OZ FEATURE—RELEASED THROUGH ALLIANCE

"THE LAST EGYPTIAN"

(Oz Film—Five Reels)

REVIEWED BY CLIFFORD H. PANGBURN

EXHIBITORS who are seeking for novel effects will find this picture one that is well worth showing. This should not be taken to imply that it has only novelty to recommend it. On the contrary, it has a good plot, excellent acting and realistic settings.

Kara, the last Egyptian, is something of a villain, but his actions are prompted by an oath which he swore to his dying grandmother. He vowed to be revenged for the harm an Englishman had done his family. The sympathies of the spectator are so well aroused that it seems almost unfortunate that he did not succeed.

The story is one of modern Egypt, and by a careful selection of outdoor scenes, and an intelligent arrangement of interior settings a most realistic atmosphere has been attained. Farrell McDonald in the title role heads a large and capable cast.

Mr. McDonald has a particularly trying part, as in addition to its other difficulties he has to appear in a sort of light blackface make-up in order to portray the swarthy Egyptian. However, the character is effectively played whether the man is seen in the rags of an Egyptian laborer or in evening clothes and in the decorations of a prince of the realm.

Jefferson Osborne gives a perfect characterization of the weak and worthless Viscount Consinor, while Vivian Reed is equally good as his attractive sister, Aneth Consinor. Others in the cast are Mai Wells, Howard Davies, Frank Moore, Jane Urban, Charles Haydon, and Ora Buckley.

At the opening of the story Kara is told by his dying grandmother of the way in which she was betrayed by a young Englishman, Lord Roane. She exacts a promise of vengeance from Kara and gives him the key to a secret treasure vault in which she tells him the family wealth is concealed. Kara, it appears, is the last of the ancient line of Egyptian kings.

Kara goes into the treasure vault and at once realizes that he is a man of wealth. He goes to Cairo, where he sets himself up in royal style, with a harem and all the other features of an Oriental home of wealth. It happens that Lord Roane, now an old man, has come with his son to Egypt, both of them holding positions in connection with the diplomatic service.

Kara meets the two Englishmen as well as Aneth, Roane's daughter. He plans to ruin the son financially and to marry the daughter by a fake ceremony, just as Lord Roane had done to his grandmother. By gambling he gets the son heavily into debt, and uses this as a means to force consent to his marriage.

It happens that he has earned the lasting enmity of a certain dragoman, and his plot is frustrated by the man's desire for revenge. At the close of the picture Kara is shut into his treasure cave, and left to die behind a rock door than can only be opened from the outside. The girl Aneth is rescued and finds happiness with her sweetheart.

DISCUSS LENGTH OF PERFORMANCES

MEMBERS of the Detroit Exhibitors' League met in conference with representatives of all of the local exchanges recently to discuss the present dissatisfaction respecting the length of shows, and to reach some equitable arrangement for the limitations on three and five reel accounts.

Officers of the league have worked for weeks to prevent the unfair competition which has resulted in many instances.

"THE MASTER KEY"

(Universal Special—Fourth Episode)

REVIEWED BY PETER MILNE

FOLLOWERS of "The Master Key" will be introduced to something sensationally thrilling in the latter part of the last reel of this episode. It is something that will create a gasp and murmur to come from everyone in the house, more than likely accompanied with the exclamation "Don't they do marvelous things in the pictures nowadays?" or some other sentence expressing similar thoughts.

It is the spectacle of an automobile in which is a number of men, including John Dore, bound on his way to the railroad



WILKERSON THREATENS GALLON

station. The car has been disabled by Wilkerson, which accounts for the inability of the driver to control it. All of the men leap from it while it is tearing along at full speed, except Dore who sticks on.

Wilkerson, to make doubly sure of putting Dore out of the way, has set fire to a bridge which the car will have to traverse. When on the middle of the bridge Dore jumps, and he is in the nick of time, as the bridge gives way and the automobile crashes into a deep gorge below and is totally wrecked, though its occupants escape.

Dore, however, manages to reach the train just in time, and the last we see of him is while on the rear platform shaking his fist at Wilkerson, bound on his way to the city to look into the mystery surrounding the disappearance of Ruth, who has fallen into the hands of Mlle. Darnell.

Dore, however, is ignorant of this fact, and what success will meet him will be made known in the next episode. Thrilling incidents have commenced now, and it looks as if the producers were going to treat us to a good many more before the serial comes to a close.

Excitement is beginning to crowd on excitement in the episodes and thrills are becoming so numerous that it seems as though every foot had one to offer.

STARS AND SCENES FROM TWO OF THE FIRST KRITERION RELEASES (MICA FILM CORPORATION)



DOROTHY DAVENPORT

SHEILA PREPARES TO
ATTEND THE DANCEFRITZI BRUNETTE IN
"GOADED JEALOUSY"SHEILA IN THE MYSTIC'S
DEN

FRITZI BRUNETTE

"THE CRYSTAL GLOBE"

(Paragon-Kriterion—Two Reels)

REVIEWED BY PETER MILNE

IT seems quite a hackneyed remark to make in reference to the future Kriterion pictures, but if they are all as good as "The Crystal Globe," their success is assured.

By no means is this a spectacular or sensational production. The story it presents, however, is one which will call forth great interest. While the theme is not unconventional it is handled and developed in an unconventional manner.

The director as usual should come in for a great part of the praise that is sure to follow the picture. Donald McDonald has produced the picture in such an effective and telling manner that our interest is not lost for one moment.

Dorothy Davenport, who appears in the leading part, gives an astonishingly excellent portrayal of the girl, Shiela, adopted while yet a baby by wealthy people, then growing to womanhood, to refuse a self-made man. Thanks to the man she sees her rather foolish decision and in the finale, after the girl has learned her true past, the two are married. Lee Hill plays opposite Miss Davenport, and his acting is equally good.

Photographically the picture is beautiful. Although none of the scenes are a glaring white, they are pleasing to the eye, and well taken, showing that they were handled by a skilled cameraman.

The exteriors have been well chosen, and the interiors are entirely in keeping with the story. One of these in particular, the Hindu mystic's den, is lavish and especially effective. It is here that Shiela has gone, drawn by the magnetism of the magician, and here she learns her past, which affords an opportunity for a little Western action to come into play, which is as well put on as the rest, and exciting.

In the scenes in which Shiela is gazing into the crystal globe, Miss Davenport renders one of the best performances she gives in the picture. Her expressions, which are fully expressive, are assumed so well and are at the same time so natural, that we are inclined to think she will be well heard from in the future.

"THE MASTER KEY"

(Universal Special—Third Episode)

REVIEWED BY PETER MILNE

WHAT will, no doubt, impress many people as a remarkable fact concerning this episode is the realistic and human-appearing mob scenes, which play no mean part as the story progresses. They are to be seen once crowded about the house of Gallon, their kind-hearted employer, waiting to hear the worst, which comes after a long hour. Gallon dies in this chapter, and the effect that it produces among his faithful employes is plainly shown by the expressions on their faces.

That the extras who took part in this scene were well trained is so plainly obvious as to warrant the heartiest of praise for the director, Robert Leonard. Their actions are realistic and true to life. It is sometimes neglected things like this, the training of the supernumeraries, that when not neglected go to make a picture perfect. They instil an air of faithful realism into the picture,

one which will most surely make its mark and earn great credit for the producers.

As said before, Gallon dies in this episode. The absence of Gallon is not to be greatly regretted, as we were hardly well acquainted with him to bemoan his loss, but the man who plays the part of Gallon, Wilbur Higby, was worthy of a greater showing than five reels. Of course, Gallon had to die to further the story, but just the same the absence of Mr. Higby is regrettable.

At the outset of this episode Gallon realizes that Wilkerson has really found him, and that it is not a vision that keeps appearing before him. Wilkerson demands a job as superintendent of the mines, and Gallon submits to his wishes much against his will. Shortly afterwards he dies. In his will he leaves all his property to his daughter, Ruth, with the exaction that she retain Wilkerson as superintendent, and that Dore be her executor.

When Dore sides with the miners in their fight against the decrease of wages effected by Wilkerson, he is discharged, but when he calms the strike a little later, the superintendent realizes

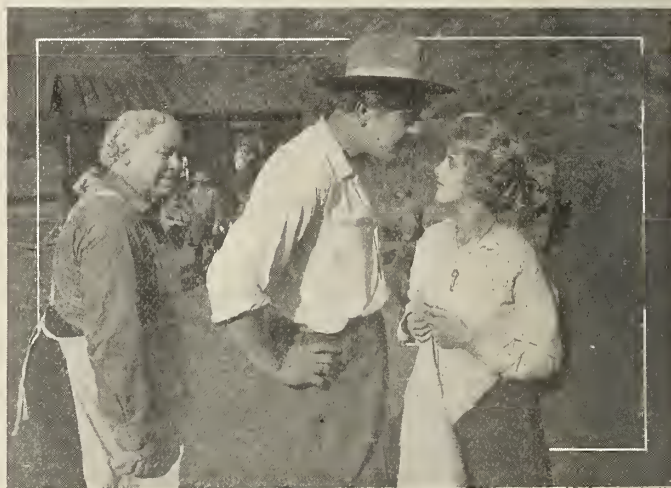
**"YOU MUST GO TO SAN FRANCISCO"**

that he is too valuable a man to lose, and reinstates him. On her father's death Ruth came into possession of "The Master Key."

With the establishment of the villain in such a commanding position, and with him already at odds with his employes, whom Dore champions, we may look for some exciting events to befall all parties in the very near future. Such a situation as is now in existence can hardly last peacefully for any length of time; an eruption is sure to occur, and with it some sensational action is due to arrive.

LIFE PHOTO CAST BACK FROM NEW ORLEANS

EDWARD M. ROSKAM, president of the Life Photo Film Corporation, returned from New Orleans with the cast which completed the filming of Booth Tarkington's drama "Springtime." Mr. Roskam was almost beside himself with enthusiasm when recounting the beauties of the production.

"WITHOUT HOPE"

(Flamingo-Sawyer—Four Reels)

REVIEWED BY H. S. FULD

"WITHOUT HOPE," the first release of the Flamingo Film Company through Sawyer, is a comedy drama in four acts, by Elaine Sterne, and a release of the first water.

Hope (Margaret Loveridge), a slavy in a restaurant, is adopted by two maiden spinsters, and taken with them when they go to a summer resort. Wetherill, a millionaire inventor (Wm. Mandeville), has perfected a formula for the manufacture of noiseless gunpowder, and while waiting for government approval goes to the same hotel with his daughter, Irene (Mary Charleson).

Van Alstyne, a writer (Harry Kendall), in love with Irene, goes to the same hotel and secures employment there disguised as a waiter, in the hopes of getting material for a story.

La Belle, a political spy in the employ of a foreign government (Catherine Proctor), with the aid of a bogus count, endeavors to get Wetherill in her toils and obtain the coveted formula.

Through the intervention of Hope, who exposes the bogus count, and Van Alstyne, who prevents La Belle from poisoning the inventor, the foreign agents are frustrated and captured.

Comedy and humorous situations follow each other in rapid succession through the course of the story. The attempts of Hope to act the lady and appear at ease in her new surroundings, her flirtation with the different male characters that come her way are masterpieces of acting.

The interior settings show extreme care in the choosing and the exteriors, especially those showing the Hudson River in the background, are beautiful, with clear photography.

The acting of the entire cast is beyond criticism, and the story is so well told by the action on the screen as to hold the attention of the observer throughout. There is not a moment in the entire four reels that does not interest, and the little humorous touches introduced in the love making scenes between Hope and her swain are truly laugh provokers.



HOPE RECOGNIZES THE BOGUS COUNT

Two love stories run their course through this film, for Irene gets Van at the end, and both she and Hope get theirs.

This release has so many redeeming points about it that it classes itself as being above the average, and should add to the producer's reputation.

SMALLWOOD PLANS NEW SERIES

THE Smallwood Film Corporation, which is now releasing one and two-reel Grandin Films, featuring Ethel Grandin through the United Film Service, will shortly begin the production of one and two-reel subjects under another brand name which has not been selected as yet.

The second release will have as leads two popular players, one of whom has been prominent in licensed programs for several years. The Smallwood Film Corporation has enlarged its industrial and educational department and has opened new offices in Chicago, St. Louis and New Haven, Conn., for the distribution and sale of these subjects.

"WHEN WEALTH ASPIRED"

(Pathé—Three Reels)

REVIEWED BY H. S. FULD

THE story of the mother who aspires to a title, and the sacrifice of a daughter to acquire such a coveted honor, is old, and has been used over and over again.

But the producers of "When Wealth Aspires" have given a new twist to it, and introduced so many novel situations as to make a rather hackneyed plot seem new. It is nothing out of the ordinary for a producer to go to great pains to make a production



THE CLIMAX AT THE DINNER

seem real by giving special attention to the stage settings for interiors or to go to great lengths to make the local color fit a particular scene.

When perfect settings that leave nothing to be desired are coupled with a cast that is alive to its respective roles, a cast whose every member seems fitted to and acts the part true to life, the production is worth seeing.

Some unexpected twists make the plot doubly interesting, and a duel scene, where the mercenary duke is wounded by the prince and subsequently pleads with Paola for forgiveness, is really above the average for such depictions.

There are so many good points in this release that it should add to the producers' reputation; and though the plot is not new, this fault is lost sight of by the masterly handling of the directors and the acting of the principals.

The total absence of padding, so noticeable in many recent so-called features, is no little item for the recommendation of this number.

"ZUDORA"

(Thanouser—Fourth Installment)

REVIEWED BY CLIFFORD H. PANGBURN

IN this installment of the newest Thanouser serial the heroine is confronted by another mystery in the solving of which she not only helps her fiance, but restores peace and happiness to his parents' home. The fact that to do so very nearly costs her her life does not seem to trouble the plucky girl in the least.

At the opening of the picture John Storm has a quarrel with Hassam Ali, during which he is saved from death at the hands of an Oriental servant only by the timely arrival of Zudora. Following this Storm goes to his parents' home in the country, having received a letter from his mother telling of a strange spectre which is haunting the region, and which is seen almost anywhere.

Arrived at his home he learns that the apparition takes the form of a skeleton hand which appears sometimes in a room, and sometimes out-of-doors, but always against some fairly flat surface. He writes of the thing to Zudora, who joins him at once. It finally develops that the skeleton hand is produced by a projecting lantern, and a slide made from an old X-ray photograph. A half-witted farm hand has been using it to frighten people. When Zudora discovers him he seizes and binds her, and is actually engaged in hanging her when her lover arrives and comes to the rescue. The regular cast appears. Marguerite Snow being very effective as Zudora.

"MORE THAN QUEEN" STAR KILLED AT FRONT

ALMOST simultaneously with the release of "More Than Queen," the fine Pathe colored picture in which Rene Alexandre starred, comes the news from France that the talented actor has been killed in the war.

Alexandre was to the Pathe French drama what Max Linder (who was recently wounded) is to the Pathe French comedy. Tall, broad shouldered and notably dignified in bearing, he invariably played opposite his beautiful wife, better known to the American public as Gabrielle Robinne.

The French Pathe actors and employees are acquitting themselves with credit in the titanic war which is convulsing Europe. So far the honor list is as follows: Rene Alexandre, killed; Max Linder, wounded, and M. Escoffier, decorated. In addition to these men two employees of the Jersey City studio who went back to fight have written to friends in this country that they are wounded—Rene Monca and M. Tricot.

"THE SILENT ACCUSER"

(Pathe—Three Reels)

REVIEWED BY CLIFFORD H. PANGBURN

THIS French-made film is not only well acted, but it is filled with the fine lighting effects and striking backgrounds which one expects in Continental pictures. A number of the scenes in the last reel are taken in the Pyrenees, and show many beautiful glimpses of deep valleys, lofty mountains and small villages nestled among the heights.

The story is one which introduces a number of complications, but which is entirely clear, and holds the attention closely. An inventor, Robert Macey, devises a telephone which projects a picture of the person using it on a screen at the other end of the line. Macey interests a capitalist, who has him live at his house while conducting his experiments.

The rich man's daughter is attracted by the inventor, who thus incurs the enmity of a bankrupt cousin, who had hoped to marry her. He succeeds in discrediting Macey so that he has to leave his patron's home. Later the capitalist dies, and the unscrupulous cousin proceeds to make some copies of Macey's telephone, and



THE INVENTOR IN TROUBLE

even tries to get his cousin to give him financial aid. This she refuses to do.

The inventor disguises himself and goes to demonstrate his device, having sent out a notice of his death and a message leaving all rights to the girl. While testing the device he sees by means of it an attack on his sweetheart and hastens to her rescue. He overtakes her and her captors, only to be seized and locked into an automobile, which is started down a hill. His youthful brother, who has been extremely useful before, saves the couple from death, as he has been hiding on the roof of the limousine, and is able to climb down and stop it. Meantime the crooked cousin kills himself by touching an overcharged wire while trying to demonstrate the telephone. The real inventor arrives and proves the worth of his device, after which he finds complete happiness in the love of the girl, who has been through so many perils on his account.

"THE BEGGAR CHILD"

(American-Mutual—Two Reels)

REVIEWED BY PETER MILNE

TWO reels of heart interest action is what "The Beggar Child" offers us, ably interpreted by the players that appear. It was released on November 30 on the regular Mutual program, but really deserves the name of feature. It is not too long and not too short—exactly the right length in fact, and a story that holds the attention all the way through.

The American company has long had a reputation for offering the trade practically the best to be had in the way of photography, and they don't fail to maintain it in this production. It is clear and distinct every foot of the way, beautifully tinted. Excellent scenes have been chosen as backgrounds for the action, which is supposed to transpire in Italy.



ROSA TELLS LYCIA THE TRUTH

In the cast are Ed Coxen, at first a poor artist who adopts a deserted little girl, and brings her up as his own daughter. The girl in her advanced age is played by Winnifred Greenwood, and because of her the artist gains fame and fortune. George Field plays the Count who falls in love with Lycia. Charlotte Burton is the woman he has wronged, and who prevents his marriage to the other woman.

"HARVARD-YALE FOOTBALL GAME"

(Colonial)

SUCH an event as the annual gridiron contest between Harvard and Yale, which attracts the attention of practically the whole country, makes a most interesting topic for the pictures. Although the game itself is interesting to watch, especially the ninety-five yard run made by Coolidge of Harvard, the incidental views will attract the eye of all, even the person who cares little for the game.

Pictures of Walter Camp, Charles Brickley and Captain Talbot, the last two the captains of the rival teams, scenes in the grandstands, especially in the cheering sections, give an excellent idea of the monstrous proportions of the much talked about Yale bowl. All in all this will prove an interesting film both for sportsmen and to those who care nothing for the game.

NO MATTER WHO YOU ARE IN THE TRADE—

manufacturer, exchange man, exhibitor, operator,
musician,

THERE IS SOMETHING FOR YOU EVERY WEEK

IN

MOTION PICTURE NEWS

and you always know
WHERE TO FIND IT

INTERESTING FILM REVIEWS

PRODUCTIONS FROM ALL PROGRAMS

GENERAL FILM PROGRAM

"Just a Kid." (Biograph. Mon., Dec. 7.)—A good heart interest story. A young chap misses a dance and incurs the displeasure of the girl he is courting in order to help a small boy who is under the control of a tramp. Later the tramp disappears, and the boy and his protector rescue the girl from a fire, and everyone is happy. The cast is headed by Charles West and Claire McDowell. Special attention has been given to the fire scene.

"Cousin Pons." (Biograph. Two reels. Tues., Dec. 8.)—This is an adaptation of the famous novel of the same name by Balzac. The story is a study of the various effects which money has on its possessors. A fine old gentleman of wealth is snubbed by his relatives until they discover that he has money. Then they not only seek his society, but bribe his housekeeper to give him a slow poison so that he will die before making a will and thus leave them his estate. Instead he makes a will leaving all his property to a friend. This is a mere skeleton of the story which is a very strong and interesting one. Charles Hill Mailes is seen in the title role. Others in the cast are Edward Cecil, Ivan Christy, Vivian Prescott, A. C. Marston and Thornton Cole.

"For Her People." (Biograph. Thurs., Dec. 10.)—An effective story of much interest. The queen of a small country is living incognito in a distant city. She meets some art students, and one of them falls in love with the young queen, who heartily reciprocates his feeling. Hearing of this, her ministers recall her to the country. There she discovers that the regent who has ruled in her absence, and who will rule if she abdicates, has been a cruel monarch. She realizes that for her people she must keep the throne. Irene Hawley and Jack Mulhall head the cast.

"And She Never Knew." (Biograph. Fri., Dec. 11.)—When an old tramp took advantage of the fact that a lonely woman thought him her long-lost brother, because he came on her birthday, he considered it a clever bit of work. Soon he repented, but then he saw that to go away would break the old lady's heart, and the story becomes still more pathetic. In the cast are Kate Bruce, Jack Young and Hector V. Sarno.

"Saved By Their Chee-ild." (Biograph. Sat., Dec. 12.)—A split reel comedy on the same reel with "Diogenes's Weekly, No. 13." A burlesque comedy satirizing the type of story in which a furious father refuses to allow his daughter to marry as she wishes, and when she elopes, captures her and is about to compel her marriage as he wishes when the hero saves the day.

"Diogenes's Weekly, No. 13." (Biograph. Sat., Dec. 12.)—A burlesque of the news pictorials. On the same reel with "Saved By Their Chee-ild."

"Buster Brown Sticks to It." (Edison. Mon., Dec. 14.)—Buster obtains a pot of powerful glue with which he fastens his grandfather to the floor, the servants to their chairs, and causes various other persons trouble. A film that should please the children. A split reel completed by a good scenic called "A Trip Through Uganda."

"The Sheriff of Willow Gulch." (Biograph. Mon., Dec. 14.)—This makes an absorbing story. The locale is the West. The action might well be termed absorbing, and the photography reaches the height of Biograph artistry. The self-sacrifice of a man for the love of a girl who likes but does not love him must always be an appealing story, and as interpreted by Isabel Rea, Franklin Ritchie and Curtis Cooksey, the plot retains a firm hold on the spectator.

"A Perilous Passage." (Lubin. Mon., Dec. 14.)—The fourteenth of the "Beloved Adventurer" series. Lord and Lady Cecil seem to have reached a peaceful career at last, but their calm is disturbed by further plots of the adroit Countess Luovich, who has stolen a diamond entrusted to the care of Lord Cecil's nephew. Betty fortunately learns who the thief is, and by an extremely plucky trick gets the jewel. The Countess and her gang are killed shortly afterwards by a landslide.

"Madame Double X." (Essanay. Mon., Dec. 14.)—A Swedie comedy with a rough-house trial the chief source of fun. Swedie as Madame Double X is arraigned on the charge of having tickled her husband to death. The husband comes to life, appears in the midst of the trial, and a free-for-all fight follows.

"The Greater Love." (Vitagraph. Mon., Dec. 14.)—Seldom has anyone in real life shown such true devotion as the hero of this strong drama. John Brown returns to his sweetheart after a year in South America. He comes home without writing and intends to surprise the girl. In the garden he overhears her tell another man that if her fiancé were dead she could love him. Believing that the girl will be happier with the other man he goes home and by means of death notices of a man of the same name leads the girl to think him dead. She then marries the other man. Dorothy Kelly and James Morrison head the cast.

"The Flirt." (Edison. Mon., Dec. 14.)—The flirt changes from one girl to another so rapidly that he soon has a band of enraged and determined females on his trail. He finally has to resort to a fake suicide, but it does not save him. Edward O'Connor is a good comic policeman. William Wadsworth and Elsie MacLeod are also in the cast.

"The Loose Change of Chance." (Essanay. Tues., Dec. 15.)—A picture adopted from a "Munsey Magazine" story dealing with the double theft of a diamond and some valuable papers. The hero is accused of the crime, but later discovers the real thieves and secures the large reward which enables him to marry his sweetheart. A good though rather involved plot, well acted by Richard Travers, Beverly Bain, Bryant Washburn and Lester Cuneo.

"A Scrap of Paper." (Biograph. Two reels. Tues., Dec. 15.)—This film story is taken from J. Palgrave Simpson's adaptation of Sardou's famous stage comedy, and as rendered by Alan Hale and William Jefferson in the parts of the lovers and Vola Smith and Louise Vale as the girls, it makes a choice comedy which all will appreciate. Others in the cast are Mrs. LaVarnie, Jack Drummer, Mary Malatesta and H. Barrington. Part of the action transpires in our own country and part abroad. It develops that a scrap of paper, or a letter, furnishes all the difficulty for the characters and all the fun for the audience.

"Out of the Past." (Vitagraph. Two reels. Tues., Dec. 15.)—In a brawl an Italian woman kills her husband in order to save her life. Later when she is happily married to an American, one of her rejected Italian suitors appears with her father and they attempt to extort from her the combination to her husband's safe under threat to blacken her reputation to such an extent that her husband will cast her off. She pleads for mercy so eloquently that her father comes to her aid and kills the other man in a stiletto duel, after which he dies of the wounds received, thus saving the wife from awkward explanations. Eulalie Jensen, William Dunn, Edward Elkas, J. Herbert Frank and Arthur Ashley compose the cast.

"The Man from the East." (Selig. Tues., Dec. 15.)—As a result of a misunderstanding between Tom Mix and his fiancée in the East, Tom returns to his former life of a Western cowboy. His sweetheart soon learns of her mistake. While she is on her way to visit an aunt on a Western ranch, Tom rescues her from a runaway stage coach, and they are happily reunited. The rescue is a remarkable piece of dare-devil riding.

"The Vanishing of Olive." (Edison. Tues., Dec. 15.)—Another of the series known under the title of "Olive's Opportunities," in which Mabel Trunelle is featured. In this story Olive is captured by crooks in the employ of her persecutors. A Chinese keeper of an opium den arranges the capture, but is terribly punished by killing his own daughter instead of Olive, when the police raid his place. Olive is rescued by her sweetheart and the officers.

"Weary Willie's Rags." (Lubin. Tues., Dec. 15.)—A split reel comedy based on the familiar situation of a tramp changing clothes with a prosperous citizen. On the same reel with "It Cured Hubby."

"It Cured Hubby." (Lubin. Tues., Dec. 15.)—A young wife tries to teach her husband a lesson by pretending to be drunk when he comes home from one of his convivial parties. By mistake she drinks some of the real stuff instead of the sarsaparilla she intended to use. The effect is surprising. Mabel Paige and C. W. Ritchie head the cast. On the same reel with "Weary Willie's Rags."

"The Egyptian Mummy." (Vitagraph. Wed., Dec. 16.)—A lively comedy concerning a professor who thinks he has discovered an elixir of life which will restore mummies to their pristine liveliness. His daughter's sweetheart sells him a "mummy" made of a hobo in a mummy case. The elixir brings him to life in a hurry. Of course, the young chap gets the girl. Billy Quirk and Constance Talmadge head the cast.

"The Test." (Selig. Wed., Dec. 16.)—Good acting by Bessie Eyton and Thomas Santschi as principles, an exciting escape from a burning vessel and excellent nautical scenes are the features of this sea drama. A fire on board the ship reveals to the captain's daughter the real worth of the mate, who loves her devotedly, and the cowardice of a wealthy passenger who has temporarily fascinated her. She marries her true lover and happiness follows.

"Two Pop Up Fables." (Essanay. Wed., Dec. 16.)—"A Fable of a Girl Who Shifted the System" is about a chatty girl who did not make a hit with the boys until she stopped talking about herself, and made them the sole subject of the conversation. Moral: "If he likes syrup, feed it to him by the gallon."

"The Fable of the Sarcastic Husband and the Lady Shopper" is about the husband of a top-speed shopper who laughs at the spool of thread that his wife brings him as a result of a whole day's shopping. The next afternoon two trucks are required to deliver her purchases. Moral: "Never arouse a sleeping shopper."

"The Bomb." (Lubin. Two reels. Wed., Dec. 16.)—The daughter of a Russian count swears to be revenged on a Grand Duke. As a matter of fact, he has only done his duty in reading a notice of banishment to her father, the shock of which had killed him. Joining the Nihilists the girl plans to aid in the assassination of the Grand Duke. He is in love with her and she cannot resist the attraction for him. When the time for killing him arrives she saves him but betrays all of her friends. Lilie Leslie and William Cohill are the principals.

"On Christmas Eve." (Edison. Wed., Dec. 16.)—A Christmas story built along the lines of a family reunion, but differing from the usual picture in the details of the plot. An extravagant wife drives her father from her home, and nearly ruins her husband. On Christmas eve she learns her errors in a strange way, and happiness for the future seems certain. In the cast are William West, Bliss Milford and Bigelow Cooper.

"The Tip of the Dark Continent." (Edison. Wed., Dec. 16.)—An interesting split reel scenic picture showing views in and about Cape Town. Some of the surf effects at the Cape of Good Hope are particularly fine.

"A Question of Clothes." (Vitagraph. Thurs., Dec. 17.)—The familiar story of the girl whose guardian orders her to marry and who runs away disguised in man's clothes in order to avoid this difficulty. A number of good comedy twists are introduced, and of course all turns out happily in the end. Van Dyke Brooke as the uncle, and Norma Talmadge as the niece are the principals.

"Red Dye." (Biograph. Split reel. Thurs., Dec. 17.)—The situations that follow when a gang of crooks live above a "sweet young thing," and above them an actress in the habit of using dye, which she spills, are almost bound to be humorous, although slightly conventional. The dye is red, so it is thought to be blood. The burlesque police enter and create added fun. This is on the same reel with "A Natural Mistake," and the cast includes Madge Kirby, who plays the lead in the other also.

"A Natural Mistake." (Biograph. Split reel. Thurs., Dec. 17.)—This is quite a lively little comedy concerning hubby's jealousy over his wife's amateur theatrical friends. A wild chase is one of the features of the picture. This and

most of the other events will strike all as humorous. The cast includes Florence Lee, Madge Kirby, D. Morris and Walter Coyle. On the same reel with "Red Dye."

"When the Blind See." (Lubin. Two reels. Thurs., Dec. 17.)—The "practical" son of a farmer inherits the farm and orders his studious younger brother off the place. He goes to the city where he works his way through a medical school with the help of his sister. Years later he has become a great eye specialist and is called in to operate on the eyes of a wealthy oil operator who turns out to be his brother. At first he refuses to treat his hard hearted relative, but his sister induces him to do so, and on the successful restoration of his sight the brothers forget their past hate. L. C. Shunway and William Parsons are seen as the brothers, and Velma Whitman as the sister.

"Snakeville's Blind Pig." (Essanay. Thurs., Dec. 17.)—A good Snakeville comedy showing the dreary existence of the male population after the women have obtained the vote. A little joy enters the men's lives with the opening of a blind pig, but Sophie, the sheriff, discovers it and puts kerosene in the whiskey. Poor Slim, deathly sick, is dragged home by the ear.

"His Prior Claim." (Biograph. Fri., Dec. 18.)—This is a pathetic offering in which an elder brother refuses to recognize the younger, after he has married a frivolous girl. After the birth of a baby girl, both the parents die, and in time the other brother learns he has a niece. He is captivated by her and urges his right to adopt it, but the child prefers to go with the woman who had adopted her before.

"The Comedienne's Strategy." (Lubin. Fri., Dec. 18.)—One of the type of silly old "gay boys" is annoying an actress by his constant proposals of marriage. To get rid of him she shows her a photograph of an acquaintance who is her husband according to her story. About that time the old man's daughter elopes and sends back the same picture as that of her husband. Trouble follows fast and heavy. In the cast are Rosemary Theby, Harry Myers, Ruth Bryan and Bartley McCullum.

"Who's Who in Hogg's Hollow." (Vitagraph. Fri., Dec. 18.)—The amusing adventures of an automobile party who are stranded in a remote town by the breaking down of their car. They discover that Phineas Hogg is the main guy in the place. In fact he holds every public and most of the private offices. As they have incurred his displeasures their lot is not a happy one. Sidney Drew is seen as Phineas.

"Girl from Thunder Mountain." (Essanay. Two reels. Fri., Dec. 18.)—This is a story of the transformation of a ragged, ignorant Virginia mountain girl into a beautiful debutante of New York society. A young engineer, who holds the poor Southern white trash in contempt, fails to recognize the girl whom he had met in the Virginia mountains after her year in New York. Of course, he falls in love and upon learning the truth is very much ashamed of his previous prejudice. The scenes are good and the photography is excellent. It is well acted by a cast with Richard Travers and Ruth Stonehouse as principals.

"The Tale of a Coat." (Selig. Fri., Dec. 18.)—An amusing comedy depicting the futile attempts of an impossible new rich family to enter society. The suitor for the pretty daughter's hand loses his coat-tail in a disagreement with father, but in spite of this succeeds in secretly marrying the daughter, and the marriage is hilariously celebrated. In the cast are John Lancaster, Elsie Greason, Lillian Leighton and Sidney Smith.

"The Birth of Our Saviour." (Edison. Sat., Dec. 19.)—A Christmas picture which handles the first Christmas in an effective and reverent manner. It shows the appearance of the angels to the shepherds and the coming of the Wise Men, and carries the story of the Saviour's childhood up to the departure of Mary and Joseph for Egypt. Gertrude McCoy appears as the Virgin, and effectively portrays this exceedingly difficult role.

"The Bond Sister." (Biograph. Sat., Dec. 19.)—This picture is aptly termed by its producers "melodrama with a moral," and it is certain that all will agree with them after once witnessing it. A member of a band of crooks attempts to reform for a girl's sake, but he is killed by his old confederates before he has had a chance to show his worth. This is played exceptionally well by Charles West and Claire McDowell in the principal roles, W. J. Buter, Frank Evans and Sidney D'Albrock supporting.

"Mr. Santa Claus." (Vitagraph. Two reels. Sat., Dec. 19.)—A touching story of the lonely Christmas which faced the widow of a French

soldier killed in the European war, and the way in which her sorrow was turned to gladness. A young fellow who has just inherited some money is responsible for her happiness, although at the start he thought that he was merely helping out an unknown and disappointed little girl. The little girl turned out to be the daughter of the pretty widow. Lillian Herbert and Arthur Ashley are the principals.

"Who's Who." (Lubin. Sat., Dec. 19.)—A blackface comedy in which a colored doctor is mistaken for a negro who has been running amuck. On the same reel with "Shall Curfew Ring To-Night?"

"Shall Curfew Ring To-Night?" (Lubin. Sat., Dec. 19.)—A burlesque of the famous story of similar name. Mabel Paige is seen as the heroine. "Who's Who" is on the same reel.

"Broncho Billy's Christmas Spirit." (Essanay. Sat., Dec. 19.)—A touching Christmas story, well done by G. M. Anderson, Lee Willard, Evelyn Selby, Eugene Clinchard and True Boardman, Jr. A poor prospector steals Broncho Billy's horse in order to buy some toys for his expectant children. Broncho Billy learns the identity of the thief, and on Christmas day comes to his cabin with a posse to hang him for the crime. On seeing the happy children and learning the motive behind the theft, each member of the posse contributes some money, and leave without carrying out their original intention.

UNIVERSAL PROGRAM

"Her Higher Ambition." (Frontier. Sat., Dec. 12.)—While the termination of this picture is supposed to depict a great sacrifice on the part of the hero of the story, it is not apparent just what the sacrifice is, due to insufficient explanation in the preceding scenes. An actor, on his vacation in the West, meets a girl who is laboring under the impression that she can sing. He knows she can't, but gives her money with which to go to the city and have her voice tried. She soon returns, much disappointed to find the actor dead. Fred Church and Edythe Sterling are in the principal roles.

"The Rural Demons." (L. K. O. Sun., Dec. 13.)—A slapstick comedy in which the profuse use of bad eggs occurs. The comedy is interrupted when at its height, to introduce scenes showing the manufacture of automobile tires, which is most interesting but seems rather out of place. It would have been better as a separate subject. Billie Ritchie and Henry Lehreman are the lovers seeking the hand of Gertrude Selby, supposedly a dainty rural maid. Lehreman has a small cyclecar in which and out of which he furnishes a lot of laughter.

"The Mountain Traitor." (Eclair. Sun., Dec. 13.)—A spicy drama of the West, concerning the life of a group of moonshiners, the treachery of one of their number because of jealousy, ending with the happy scene of two lovers reunited. Photographically and scenically the picture leaves little room for improvement, and the theory is clear, concise and well built. Altogether an excellent one reeler. Stanley Walpole and Irma Earle are the lovers.

"The Mill Stream." (Imp. Two reels. Mon., Dec. 14.)—This production is noticeable for the artistry and appropriateness of its scenes, which are laid in the country about an old mill. The young mill owner, in protecting the girl he loves from a new friend, is accused of murdering him, when in reality he is killed by a thief. Evidence is brought to light that clears his name and all ends well. King Baggot plays the leading part and is ably assisted by Arline Pretty and Robert Hill.

"The Wayward Son." (Victor. Mon., Dec. 14.)—This picture brings into the limelight Daddy Manley, as he is called by his co-actors, who, directed by H. C. Mathews, has been given a role exactly suited to his personality. As an old man he expectantly awaits for the return of his prodigal son, whom a young girl is making into a man before she allows him to return. Elsie Albert is the girl. This offering will draw on the sympathies of all and will not fail to make its mark.

"Lizzie's Fortune." (Sterling. Mon., Dec. 14.)—Three boarders in a tenth rate boarding house dislike the maid-of-all-work until they see half a letter which says she has inherited a fortune. Then they all proceed to make love to the young lady. One is accepted, and then it is discovered that all the fortune was used in paying the lawyer's fee. The accepted gentleman tries his best to free himself from the girl, but she pursues him, even into the water. Louise Fazenda is the girl, and Max Asher plays the part of one of the lovers. The reel is rather dull.

"Such a Mistake." (Crystal. Split reel. Tues., Dec. 15.)—The Crystal company seems to be afflicted with the malady of producing pictures without a point, and which have no real result; this is an excellent sample of that variety. Charlie and Vivian are both jealous of each other and proceed to flirt with their servants, finally compromising and making love to each other. On the same reel with "The Glass Pistol."

"The Glass Pistol." (Crystal. Split reel. Tues., Dec. 15.)—Slightly funnier than its mate, but falling way short of real humor. A tramp procures a glass pistol from two boys and proceeds to hold everyone up with it until he is captured by the police. On the same reel with "Such a Mistake."

"The Boy Mayor." (Nestor. Tues., Dec. 15.)—This picture is put out with the idea of giving a portrayal of the methods of which the Junior Municipal Organization of Portland, Ore., does its work, and is a very entertaining reel. A gang of thieves is captured through their efforts in this film.

"A Game of Wits." (Eclair. Two reels. Wed., Dec. 16.)—This is a fascinating story of love and politics, which holds one's attention every minute of the way. The stolen treaties by an under secretary, who desires to give them to a spy; their recovery by a secret service agent, who pardons the secretary, form the basis of the story, which is alive with action all the way through. In the cast are Ernest Evers, Carol Holloway, Stanley Walpole and Will Sheerer.

"How Father Won Out." (Joker. Wed., Dec., 16.)—Rather an old theme, that of dad beating out his son for the hand of a young girl, but cleverly played by Ernest Shields as the son and Ed. Boland as his rival. Shields' eccentricities, which are forever cropping out in the parts he plays, are of the funniest sort, and will not pass without creating a lot of laughter.

"The Fatal Hansom." (Sterling. Thurs., Dec. 17.)—Two cabmen are rivals in love as well as business, and their antagonism leads them into many a quarrel. When one of them is seated in the cab with the object of his and the other's affections, and the other is perched aloft driving the vehicle at great speed, the chances are that the spectacle will strike many on the humorous side. All the principals end up struggling in the water in the finale.

"Gates of Paradise." (Imp. Thurs., Dec. 17.)—This picture affords a striking contrast in the homes of the rich and the poor before Christmas. A pretty store is presented full of the Christmas spirit, and although slightful old, will surely be enjoyed by all Violet Mercereau, William Shay and William Welsh are the principals.

"Ambition." (Rex. Two reels. Thurs., Dec. 17.)—An engaging offering produced by Ben Wilson. The theme is not new by any means but is entertaining as one could desire. The scenes in the theatre, behind the scenes, and on the stage are undeniably realistic. An artist's wife deserts her husband, taking with her her child, with the former's permission and returns to the stage, in which profession she reaches the topmost notch of popularity. She neglects her child and it dies. Then we have a little touch of the melodramatic when her husband dashes through the orchestra in the middle of a performance and denounces his wife before a crowded house. She relents and the subsequent reunion of husband and wife is very touching.

"Heart of the Hills." (Victor. Three reels. Fri., Dec. 18.)—A Mary Fuller picture that deserves more than average praise. Supporting Miss Fuller is Charles Ogle, who seems a little too old to play the lover. A land grabber learns through his son that he has swindled the father of a wild mountain girl whom his son loves, he then gives the land back. In the city the girl is the victim of the jealousy of the man's sister, but when she meets her old friend all ends well.

"His Dog-Gone Luck." (Nestor. Fri., Dec. 18.)—Ed Lyons as the penniless actor-boarder robs his landlady of her dog, and then to receive her good graces he returns it. This is a humorous offering that contains no rough work.

"His Doctor's Orders." (Joker. Sat., Dec. 19.)—This comedy has such an unconventional conclusion after the everyday beginning that it is truly refreshing to witness. William Franey, Ralph McComas and Louise Fazenda are the chief comedians, and all three appear at their best. In order to escape from his mother-in-law the husband feigns illness and is ordered to take an ocean trip by his friend, the doctor. Instead they both journey to the seashore where their wives also decide to come. News is brought to the hotel that the ship the two men were on has gone to the bottom, so they pretend to be shipwrecked and arrive at the beach on an upturned boat. Then comes the startling surprise that the ship wasn't wrecked at all, and then mother-in-law and wife get busy.

"The Christmas Spirit." (101 Bison. Two reels. Sat., Dec. 19.)—How a tramp poses as Santa Claus for the children at the instigation of their parents, and how on telling his story it develops that he is the father of one of his listeners, makes a very good story. Played by Murdock, MacQuarrie and supporting company in a very good way.

MUTUAL PROGRAM

"The Wild and Woolly West." (Princess. Fri., Nov. 27.)—An Eastern farm hand reads tales of the West and, buying a cowboy outfit from a Chicago mail order house goes to Colorado Springs. There he finds his costume fully as ridiculous as it would have been in Boston. He is glad to take a job on a farm, as soon as his money gives out. A considerable part of the film is taken up with scenic views in the Garden of the Gods.

"Among the Mourners." (Keystone. Sat., Nov. 28.)—The usual riot of slapstick comedy which one expects in a Keystone picture, but also the usual generous supply of laughs. The story concerns a man who pretends to be dead and the results which follow when he sees various mourners already seeking the hand of his supposed widow.

"The Kaffir's Skull." (Reliance. Two reels. Sat., Nov. 28.)—An unusual sort of story, which holds the attention closely. A South African diamond miner sends an uncut diamond to the United States. He packs it in a skull, placed inside of a hat box, and forwards it to himself under an assumed name. This he tells his niece in a letter. On the arrival of the steamer the girl finds her uncle is not on board. With her sweetheart she makes an unsuccessful attempt to get the hat box from the express company, but has to wait until the annual sale of unclaimed baggage. There the two oriental thieves who have followed the box bid against them, but the lovers get the box, and after some more adventures, end their troubles and convert the gem into cash on which to start married life.

"A Denver Romance." (Thanouser. Sun., Nov. 29.)—A Western girl elopes with a young man from the East, who is visiting her at her father's ranch. Then they go home, and the young husband, after a little rather silly waving of pistols, gets the father's blessing. A long section of the picture is devoted to showing scenes about the city of Denver. Mignon Anderson, John Lehnberg and Morris Foster make up the cast.

"The Sisters." (Majestic. Two reels. Sun., Nov. 29.)—The first appearance together of the sisters, Lillian and Dorothy Gish, who are seen as May and Carol, from whom the play is named. The acting of the two young players is excellent, especially when the difficult nature of their parts is considered. Elmer Clifton and W. E. Lawrence as the lovers and later the husbands of the two girls, also do some effective work. The younger sister is courted by a country youth, but she favors the attention of a young chap from the city, who is much interested in her. He then meets her older sister and at once forgets Carol. The younger sister is so overcome with jealousy that she even thinks of killing the older girl. Later she marries her country suitor. Both girls have babies at about the same time, but May's dies immediately, and the mother is in great danger of becoming insane with worry. Her husband induces the younger sister to loan her baby until the condition of the other mother allows her to be told of the truth. Carol does this, although it nearly breaks her heart to give up her baby even for a short time. Finally the older sister learns the truth by accident, and the two sisters are brought together in a happy reconciliation.

"Leading Lizzie Astray." (Keystone. Mon., Nov. 30.)—One of the Fatty series of Keystone comedies, and one of the best of these yet issued. It is a burlesque of the story of the villain who takes a girl to the great city. Fatty goes to the rescue. The scenes in the "low dive" beggar description.

"The Center of the Web." (Thanouser. Tues., Dec. 1.)—A very interesting feature of this picture is the work of the police dogs, which chase the counterfeiters and follow them into all sorts of strange places for dogs to go, one of them even climbing a tree. A secret service officer is in love with a girl who is secretly in league with a gang of counterfeiters. The girl at first decides to reform, then becomes worse than ever as a result of jealousy, but finally saves the detective's life when the gang of crooks attacks him. The action of the story is very rapid and, as mentioned above, the police dogs add much to the interest. In the cast are Claire Kroell, Frank Wood and Sam Niblack.

"Shotguns That Kick." (Keystone. Thurs., Dec. 3.)—An excellent comedy introducing some decidedly novel situations, such as Fatty playing William Tell, and shooting an apple from his sweetheart's head with a shotgun. At the conclusion of the story Fatty literally falls into a camp of three crooks, and holds them at bay until the sheriff and his men arrive.

"Naidra, the Dream Woman." (Thanouser. Fri., Dec. 4.)—The dream of an old scientist, who has hoped to discover the secret of artificially creating life. He dreams that he has created a beautiful woman, and falls in love with her, only to have a young organist win the girl on sight. Mignon Anderson is seen as Naidra, with Riley Chamberlain as the scientist.

"The Creator of 'Hunger.'" (Princess. Fri., Dec. 4.)—A very plain yet engaging offering concerning an artist and the theft of his painting by a woman, jealous of his model and a confederate. The thieves win the prize with the picture, but the model turns up just in time, accompanied by her blind father, to denounce the culprits. Boyd Marshall is the artist and Mayre Hall the poor girl, who so wins the artist's heart by her every action that he marries her.

"Who Shot Bud Walton?" (Reliance. Two reels. Sat., Dec. 5.)—George Patullo, writer of Western stories, is responsible for this tale of the old days in the cattle country. Bud Walton, a cheap bad man, tries to run Slim out of town so that he can get his girl. During a row in a saloon Bud is shot, but the wound is found to have been caused by a 30-30 rifle bullet. This had been fired by Slim's sweetheart, but evidence points to Slim as the murderer. He is about to be convicted, having refused to comment on the case, when the girl appears in court and tells her story. The verdict is that "Bud jest nacherly died." Francelia Billington is seen as the girl.

"Getting Acquainted." (Keystone. Sat., Dec. 5.)—Mabel Normand and Charles Chapman in a fast moving slapstick comedy of errors. Two married couples are in a park and each husband tries to flirt with the other one's wife. A policeman wishes to prevent all kinds of flirting, and attacks both husbands indiscriminately. Not a dull minute.

"Sherman Was Right—It's Very Trying." (Royal. Sat., Dec. 5.)—A queer jumble almost without the semblance of a plot but very funny, due to the humorous actions of two bodies of soldiers who are at war with each other. Everything conceivable is burlesqued. The Royal horse, which is becoming familiar in these comedies, plays quite an important part and furnishes many laughs. Louis Simon appears as Napoleon.

"Mr Hadley's Uncle." (Komic. Sun., Dec. 6.)—The twelfth of the Bill series featuring Tammany Bill Young and Fay Tincher. Bill's employer is expecting his wealthy uncle who has agreed to back him in a deal. During his absence an escaped lunatic arrives, and is received by the stenographer as Mr. Hadley's uncle. He buys the typist an automobile and gives her a check for \$5,000 for candy, but before long her sweet dream is shattered, when the mistake is discovered.

"The Amateur Detective." (Thanouser. Sun., Dec. 6.)—Burdened with a conventional plot, the players of this offering make the most of their opportunities and afford a number of laughs. Father refuses his daughter's suitor, until he procures \$5,000, which he does by threatening the gentleman with secret signs and then charging him the required sum to fathom the mystery. Muriel Ostriche is the girl, and Carey L. Hastings is in the role of the cook of the establishment, and will create a number of laughs.

"A Question of Courage." (Majestic. Two reels. Sun., Dec. 6.)—There is a rare touch of real dramatic strength in this story of war. A mother sends her three sons to fight for the Union. Two of them are killed, and then the last and youngest stops for a visit as he rides by to a battle. His mother, overcome by grief, forces him to drink some coffee in which she has placed sleeping powders. Thus she keeps him from the battle. After it is over he is arrested as a deserter, and his mother goes to ask for his pardon. General Grant stops at the house and the old family servant tells him the whole story. He rides on to the camp, where the boy is being tried and orders his release. Mrs. Crowell does a remarkable piece of acting as the mother.

"Other People's Business." (Keystone. Mon., Dec. 7.)—The willingness with which many persons pass about supposed scandal forms the basis for this amusing burlesque. A gossiping man at a picnic thinks to catch a friend's wife flirting with another man, but instead catches his own spouse, and makes himself the laughing stock of the whole party.

"Out of the Darkness." (American. Two reels. Mon., Dec. 7.)—How an old convict apparently beyond any hope of reformation was influenced to take a risk that cost him his life is depicted in this picture. It was his love for his daughter which prompted him to restore some stolen money after he learned that his daughter was the sweetheart of the man who would be blamed for the loss of the cash. The girl's lover had been released from prison on the same day with her father, but was living a straight life. The older man took advantage of the younger one's kindness to steal his keys and go to the office where he worked. On discovering that his act would probably ruin his daughter's life he returned the money, but in doing so was fatally wounded by a shot from the watchman. He dies in the presence of the wife and daughter he had treated so cruelly in the past. Vivian Rich and William Garwood are featured. A strong picture.

"Our Mutual Girl, No. 47." (Reliance. Mon., Dec. 7.)—In the first scene of this chapter Margaret meets Douglas Fairbanks, the actor, and then, accompanied by Ralph Hamilton, repairs to the Yale-Princeton football game at Princeton. Various points of interest in the college town are shown, and besides the game the antics of the collegians after it is over are reproduced on the film. This is a very interesting number, and will be well appreciated.

"Her Brave Hero." (Majestic. Tues., Dec. 8.)—In this comedy a sleeping powder is the basis of all the fun. Hubby buys it for his wife, as he wishes to go out to a masquerade. She discovers this and places it all in a decanter of whiskey. This the maid takes and gives some of it to her lover, the cop. A burglar then enters the house and takes a drink and straightway falls asleep. The husband comes home and arrests the burglar and then they all take a drink. Baldy Belmont is seen to excellent advantage in the role of the husband, and Billie West is funny as the maid. Nothing bordering on the rough slapstick appears, and for this very reason the comedy will highly please.

"Limping to Happiness." (Beauty. Tues., Dec. 8.)—An engaging little comedy dealing with two lovers, their quarrel and how they are reconciled. This latter process is effected by both of the young people feigning lameness so as to attract the other's sympathy. Joseph Harris and Afton Mineer are the lovers and Kathie Fischer appears as the girl's sister. Although this story is old, it is dealt with in such a delightfully clean and capable manner by the players that it will both please and charm.

"The Reader of Minds." (Thanouser. Two reels. Tues., Dec. 8.)—This drama has for its nucleus an invention, based on such far-fetched principles, that of photographing the thoughts of the human mind, that the dramatic effect is lowered. This invention is utilized by a spy to obtain the plans of another invention, belonging to a young army officer. When it becomes known that the plans have been stolen, the young man is disgraced, but later he is cleared by his sweetheart, a telephone operator, who overhears the spies conferring. The action is rapid and the story entertaining; the acting of the two heavies is in particular very good. Muriel Ostriche appears as the telephone girl.

"The Forest Thieves." (Reliance. Wed., Dec. 9.)—This is somewhat of a detective drama, containing nothing unusual but, nevertheless, it is entertaining, and will be enjoyed by everyone. How a forest-ranger assisted by his sweetheart, the post mistress, apprehended and arrested two land grabbing officials is the theme. It is played convincingly by Fred Burns as the hero, Florence Crawford as the girl and George Siegemann as the chief offender.

"The Girl in Question." (American. Wed., Dec. 9.)—Such a genuinely pleasing comedy-drama is not very often produced. This picture shows how a dear old mother influenced her son to marry a decent girl instead of a woman unworthy of any man's affections. She accomplishes this by inviting the coarse woman and her friends to dine with her, and then she so shocks her son by acting just as they do, that he soon sees the folly of his ways. Louise Lester is seen at her best in the role of the mother and William Garwood is good as her son. Vivian Rich appears as the girl the young man eventually marries, and Josephine Ditt is the other woman.

"The Fortunes of War." (Kaybee. Two reels. Fri., Dec. 11.)—Fast action and effective scenery characterize this fine picture. The Mexican revolution is used as the basis of the story, which for this reason suggests the many Westerns with Mexican characters which have been produced. "The Fortunes of War," however, is different from the general run of such pictures and much superior. Besides the interesting and exciting story, the perfect photography and beautiful scenes add to the entertainment value of the film.

(Continued on page 96.)

Record of Current and Coming Releases

GENERAL FILM PROGRAM

RELEASES OF NEXT WEEK

Monday, December 14, 1914.

BIOGRAPH—The Sheriff of Willow Gulch, D., 1000...	16635
EDISON—The Flirt, C., 1000.....	16641
ESSANAY—Madame Double X, C., 1000.....	16643
KALEM—The Smugglers of Lone Isle, D., 2000.....	16636
LUBIN—A Perilous Passage, D., 1000.....	16644
SELIG—The Lure of the Windigo, 2000.....	16638
SELIG—Hearst-Selig News Pictorial, No. 83, N., 1000..	16642
VITAGRAPH—The Greater Love, D., 1000.....	16640

Tuesday, December 15, 1914.

BIOGRAPH—A Scrap of Paper, D., 2000.....	16652
EDISON—The Vanishing of Olive, D., 1000.....	16645
ESSANAY—The Loose Change of Chance, D., 1000....	16646
KALEM—Cupid Backs the Winners, C., 1000.....	16651
LUBIN—It Cured Hubby, C., and Weary Willie Rags, C., Split Reel.....	16650
SELIG—The Man from the East, D., 1025.....	16647
VITAGRAPH—Out of the Past, D., 2000.....	16648

Wednesday, December 16, 1914.

EDISON—On Christmas Eve., D., 1000.....	16654
ESSANAY—Two Pop-Up Fables, C., 1000.....	16657
KALEM—The Hate that Withers, D., 2000.....	16655
LUBIN—The Bomb, D., 2000.....	16660
SELIG—The Test, D., 1000.....	16659
VITAGRAPH—The Egyptian Mummy, C., 1000.....	16658

Thursday, December 17, 1914.

BIOGRAPH—A Natural Mistake, C., and Red Dye., C., Split Reel.....	16662
ESSANAY—Snakeville's Blind Pig, C., 1000.....	16663
MINA—The Thrilling Adventures of Verance, C., 1000.	16668
LUBIN—When the Blind See, D., 2000.....	16664
SELIG—Hearst-Selig News Pictorial No. 84, N., 1000..	16667
VITAGRAPH—A Question of Clothes, C., 1000.....	16666

Friday, December 18, 1914.

BIOGRAPH—His Prior Claim, D., 1000.....	16678
EDISON—The Colonel of the Red Hussars, D., 3000...	16691
ESSANAY—The Girl from Thunder Mountain, D., 2000.	16672
KALEM—Through the Keyhole, C., 1000.....	16674
LUBIN—The Comedienne's Strategy, C., 1000.....	16677
SELIG—The Tail of a Coat, C., 1000.....	16675
VITAGRAPH—Who's Who in Hogg's Hollow, C., 1000.	16676

Saturday, December 19, 1914.

BIOGRAPH—The Bond Sinister, D., 1000.....	16684
EDISON—The Birth of Our Saviour, D., 1000.....	16679
ESSANAY—Broncho Billy's Christmas Spirit, D., 1000.	16680
ESSANAY SPECIAL—The Battle of Love, D., 3000...	
KALEM—The Black Diamond Express, D., 1000.....	16684
LUBIN—Who's Who, C., and Shall Curfew Ring To- night, C., Split Reel.....	16681
SELIG—The Lady or the Tigers, D., 1000.....	16686
VITAGRAPH—Mr. Santa Claus, C., 2000.....	16682

RELEASES OF THE WEEK AFTER

Monday, December 21, 1914.

BIOGRAPH—A Matter of Court, and The Dentist's Janitor, C., Split Reel.....	
EDISON—The Adventure of the Wrong Santa Claus, C., 1000.....	
ESSANAY—Their Cheap Vacation, C., 1000.....	
KALEM—The Mayor's Secretary, D., 2000.....	
LUBIN—In Port o' Dreams, D., 1000.....	
SELIG—Hearst-Selig News Pictorial, No. 85, N., 1000..	
SELIG—Till Death Us Do Part, D., 2000.....	
VITAGRAPH—Arthur Truman's Ward, D., 1000.....	

Tuesday, December 22, 1914.

BIOGRAPH—On the Heights, D., 2000.....	
EDISON—Olive Is Dismissed, D., 1000.....	
ESSANAY—The Volunteer Burglar, D., 1000.....	
KALEM—The Winning Whiskers, C., 1000.....	
LUBIN—His Suicide, and Flossie's Daring Loyalty, C., Split Reel.....	
SELIG—Wade Brent Pays, D., 1000.....	
VITAGRAPH—By the Governor's Order, D., 2000.....	

Wednesday, December 23, 1914.

EDISON—'Twas the Night Before Christmas (Fantasy), and The Tip of the Dark Continent, E., Split Reel..	
ESSANAY—The Fable of the Husband Who Showed Up and Did His Duty, C., 1000.....	
KALEM—The Fatal Opal, D., 2000.....	
LUBIN—The Single Act, D., 2000.....	
SELIG—One Traveler Returns, D., 1000.....	
VITAGRAPH—The Professor's Romance, C., 1000....	

Thursday, December 24, 1914.

BIOGRAPH—The Suffering of Susan, C., 1000.....	
ESSANAY—Slippery Slim Gets Fair, C., 1000.....	
LUBIN—A Soldier of Peace, D., 2000.....	
MINA—A High Old Time, C., 1000.....	
SELIG—Hearst-Selig News Pictorial, No. 86, N., 1000..	
VITAGRAPH—The Knight Before Christmas, C., 1000.	

Friday, December 25, 1914.

BIOGRAPH—The Way Home, D., 1000.....	
EDISON—The Premature Compromise, D., 2000.....	
ESSANAY—Any Woman's Choice, D., 1000.....	
KALEM—The Reformation of Ham, C., 1000.....	
LUBIN—The Lure of the Green Table, D., 1000.....	
SELIG—Doc Yak and Santa Claus, C., 1000.....	
VITAGRAPH—Sweeney's Christmas Bird, C., 1000....	

Saturday, December 26, 1914.

BIOGRAPH—His Unwitting Conquest, D., 1000.....	
EDISON—The Man Who Vanished, D., 1000.....	
ESSANAY—Broncho Billy and the Sheriff's Office, D., 1000.....	
KALEM—The Escape on the Limited, D., 1000.....	
LUBIN—Brannigan's Band, C., and A Troublesome Cat, C., Split Reel.....	
SELIG—The Champion Bear Slayer, C., 1000.....	
VITAGRAPH—An Affair for the Police, C., 2000.....	

RECORD OF CURRENT AND COMING RELEASES — Continued

UNIVERSAL PROGRAM RELEASES OF NEXT WEEK

Monday, December 14, 1914.

IMP—The Mill Stream, D., 2000..... 4395
STERLING—Lizzie's Fortune, C., 1000..... 4398
VICTOR—The Wayward Son, D., 1000..... 4397

Tuesday, December 15, 1914.

CRYSTAL—Such a Mistake, and The Glass Pistol, S. R. 4403
GOLD SEAL—The Ghost of Smiling Jim, D., 2000.... 4401
NESTOR—The Boy Mayor, D..... 4404

Wednesday, December 16, 1914.

ANIMATED WEEKLY—No. 145, N., 1000..... 4409
ECLAIR—A Game of Wits, D., 2000..... 4406
JOKER—How Father Won Out, and The Ascent of the
Ingrar Neilson, Split Reel..... 4405

Thursday, December 17, 1914.

IMP—Within the Gates of Paradise, D., 1000..... 4410
REX—Ambition, S., 2000..... 4411
STERLING—The Fatal Hansom, C., 1000..... 4413

Friday, December 18, 1914.

NESTOR COMEDY—His Dog Gone Luck, and Here
and There in Japan with Homer Croy, C., 1000.... 4414
POWERS—Ghost of Sea View Manor..... 4418
VICTOR—Mary Fuller, in "Heart of the Hills," D., 3000 4415

Saturday, December 19, 1914.

101 BISON—The Christmas Spirit, D., 2000..... 4421
FRONTIER—School Teacher of Angel Camp..... 4420
JOKER—His Doctor's Orders, C., 1000..... 4419

Sunday, December 20, 1914.

ECLAIR—The Jewel of Allah, D., 1000..... 4426
L-KO—The Baron's Bear Escape, C., 1000..... 4425
REX—A Page from Life, D., 2000..... 4423

RELEASES OF THE WEEK AFTER

Monday, December 21, 1914.

IMP—In Sunny Spain, Mary Pickford Reissue, C., 1000.
STERLING—Carmen's Romance, C., 1000.....
VICTOR—Terence O'Rourke, "The King and the Man,"
2000

Tuesday, December 22, 1914.

CRYSTAL—Vivian's Beauty Test, C., 1000.....
GOLD SEAL—The Call of the Waves, D., 2000.....
NESTOR—For I Have Toiled, D., 1000.....

Wednesday, December 23, 1914.

ANIMATED WEEKLY—Weekly No. 146, N., 1000....
ECLAIR—The Fortunes of Margaret, D., 2000.....
JOKER—Love and Spirits, C., 1000.....

Thursday, December 24, 1914.

IMP—No Release This Week.....
REX—The Big Sister's Christmas, D., 2000.....
STERLING—Innocent Dad, C., 1000.....

Friday, December 25, 1914.

NESTOR—Who Stole the Bridegroom, C., 1000.....
POWERS—Hunting in Crazyland, Cart., and Japanese
Silk Industry, E., Split Reel.....
VICTOR—The Accusation, D., 2000.....

Saturday, December 26, 1914.

101 BISON—The Law of the Range, D., 3000.....
FRONTIER—The Rustler Outwitted, D., 1000.....
JOKER—Hot Stuff, C., 1000.....

Sunday, December 27, 1914.

ECLAIR—For the Defence, D., 1000.....
L-KO—The Manicure, C., 1000.....
REX—Her Escape, D., 2000.....

MUTUAL PROGRAM RELEASES OF NEXT WEEK

Monday, December 14, 1914.

AMERICAN—In Tune, D., 2000..... 02728
KEYSTONE—Fatty's Magic Pants, C., 1000..... 02731
RELIANCE—Our Mutual Girl, 1000..... 02730

Tuesday, December 15, 1914.

BEAUTY—Her Younger Sister, D., 1000..... 02736
MAJESTIC—At Dawn, D., 1000..... 02735
THANHOUSER—The Barrier of Flames, D., 2000.... 02733

Wednesday, December 16, 1914.

AMERICAN—The Silent Way, D., 1000..... 02740
BRONCHO—The Panther, D., 2000..... 02738
RELIANCE—The Joke on Yellentown, C., 1000..... 02741

Thursday, December 17, 1914.

DOMINO—The Political Feud, D., 2000..... 02743
KEYSTONE—Hogan's Annual Spree, C., 1000..... 02745
MUTUAL WEEKLY—No. 103, N., 1000..... 02746

Friday, December 18, 1914.

KAY BEE—The Game of Life, D., 2000..... 02748
AMERICAN—Trapped by a Heliograph, D., 1000.... 02751
PRINCESS—Shadows and Sunshine..... 02750

Saturday, December 19, 1914.

KEYSTONE—Not Decided, C., 1000..... 02754
RELIANCE—The Beat of the Year, 2000..... 02752
ROYAL—Two Kisses, 1000..... 02755

Sunday, December 20, 1914.

KOMIC—Bill and Ethel at the Ball, No. 13, C., 1000.... 02758
MAJESTIC—In Fear of His Past, 2000..... 02756
THANHOUSER—Sid Nee's Finish, C., 1000..... 02759

RELEASES OF THE WEEK AFTER

Monday, December 21, 1914.

AMERICAN—The Sower Reaps, D., 2000.....
KEYSTONE (Special)—Fatty and Minnie He-Haw, 2000
KEYSTONE—Title Not Announced.....
RELIANCE—Our Mutual Girl, No. 49, 1000.....

Tuesday, December 22, 1914.

BEAUTY—Brass Buttons, C., 1000.....
MAJESTIC—The Better Way, D., 1000.....
THANHOUSER—Under False Colors, D., 2000.....

Wednesday, December 23, 1914.

AMERICAN—The Tin Can Shack, D., 1000.....
BRONCHO—The Passing of Two Gun Hicks, D., 2000..
RELIANCE—A Lucky Disappointment, 1000.....

Thursday, December 24, 1914.

DOMINO—The Last of the Line, D., 2000.....
KEYSTONE—Title Not Announced.....
MUTUAL WEEKLY—Weekly No. 104, N., 1000.....

Friday, December 25, 1914.

PRINCESS—When Fate Rebelled, D., 1000.....
RELIANCE—Bobby's Medal, D., 1000.....
KAY BEE—In the Sage Bush Country, D., 2000.....

Saturday, December 26, 1914.

KEYSTONE—Title Not Announced.....
RELIANCE—The Exposure, D., 2000.....
ROYAL—Her Mother's Voice, D., 1000.....

Sunday, December 27, 1914.

KOMIC—Love and Business, C., 1000.....
MAJESTIC—How Hazel Got Even, 2000.....
THANHOUSER—A Hatful of Trouble, C., 1000.....

RELEASE DATES FOR READY REFERENCE

GENERAL FILM PROGRAM

BIOGRAPH

- 11-26. The Way Back, D..... 998
- 11-27. His Old Pal's Sacrifice, D.....1000
- 11-28. Little Miss Make-Believe, D.....1000
- 11-30. A Mother's Way, D.....1000
- 12-1. The Closing Web, D.....1000
- 12-3. In Quest of a Story, D.....1000
- 12-4. Making Him Cough Up, C..... Bertha, the Buttonhole-Maker..... 1000
- 12-5. The Deacon's Son, D.....1000
- 12-7. Just a Kid, C.....1000
- 12-8. Cousin Pons, D.....2000
- 12-10. For Her People, D.....1000
- 12-11. And She Never Knew, D.....1000
- 12-12. Saved by Their Chee-ild! and Diogenes Weekly No. 13, C.....1000
- 12-14. The Sheriff of Willow Gulch, D.....1000
- 12-15. A Scrap of Paper, D.....2000
- 12-17. A Natural Mistake, C., and Red Dye, C., split reel..... 1000
- 12-18. His Prior Claim, D.....1000
- 12-19. The Bond Sinister, D.....1000
- 12-21. A Matter of Court, C., and The Dentist's Janitor, C..... Split reel
- 12-22. On the Heights, D.....2000
- 12-24. The Suffering of Susan, C.....1000
- 12-25. The Way Home, D.....1000
- 12-26. His Unwitting Conquest..... 1000

EDISON

- 11-30. Wood B. Wedd Goes Snipe, C.....1000
- 12-1. The Girl of the Open Road..... 1000
- 12-2. A Double Elopement, C.....1000
- 12-4. Who Goes There? C.....2000
- 12-5. It's a Bear, C.....1000
- 12-7. Crystals, Their Making and Beauty, E. 500 Buster Brown Causes a Commotion, C..... 500
- 12-8. The Rose at the Door, D.....1000
- 12-9. A Matter of High Explosives, C.....1000
- 12-11. The Best Man, D.....2000
- 12-12. The Stenographer, D.....1000
- 12-14. The Flirt, C.....1000
- 12-15. The Vanishing of Olive, D.....1000
- 12-16. On Christmas Eve, D.....1000
- 12-18. The Colonel of the Red Hussars, D.....1000
- 12-19. The Birth of Our Saviour, D.....1000
- 12-21. The Adventures of the Wrong Santa Claus, C.....1000
- 12-22. Olive Is Dismissed, D.....1000
- 12-23. 'Twas the Night Before Christmas, Fant..... 550 The Tip of the Dark Continent, E..... 450
- 12-25. The Premature Promise, D.....2000
- 12-26. The Man Who Vanished, D.....1000
- 12-28. Dr. Daly's Wedding Day, C.....1000
- 12-29. The Lesson of the Flames, D.....1000
- 12-30. The Courtship of the Cooks, C.....1000

ESSANAY

- 12-1. The Buffer, D.....1000
- 12-2. The Fable of "The Club Girls and the Four Times Veteran," C.....1000
- 12-3. Sophie's Fatal Wedding, C.....1000
- 12-4. The Time, the Place and the Man...2000
- 12-5. Broncho Billy's Judgment, D.....1000
- 12-7. Sweedie and the Hypnotist, C.....1000
- 12-8. Mrs. Trenwith Comes Home, C.....1000
- 12-9. The Fable of the Bush-League Lover Who Failed to Qualify, C.....1000
- 12-10. Sophie's Sweetheart, C.....1000
- 12-11. Every Inch a King, two reels, D.....2000
- 12-12. Broncho Billy's Dad, D.....1000
- 12-14. Madam Double X, C.....1000
- 12-15. Loose Change of Chance..... 1000
- 12-16. Two Pop-Up Fables, C.....1000
- 12-17. Snakeville's Blind Pig, C.....1000
- 12-18. The Girl from Thunder Mountain, D.....1000
- 12-19. Broncho Billy's Christmas Spirit, D.....1000
- 12-19. The Battle of Love (Special Feature), D.....3000
- 12-21. Their Cheap Vacation, C.....1000
- 12-22. The Volunteer Burglar, D.....1000
- 12-23. The Fable of "The Husband Who Showed Up and Did His Duty," C.....1000
- 12-24. Slippery Slim Gets Square, C.....1000
- 12-26. Broncho Billy and the Sheriff's Office, D.....1000

KALEM

- 12-7. The Price of Silence, Alice Joyce Series, D.....2 reels
- 12-8. In Dutch, C.....1 reel

- 12-9. The Mystery of the Yellow Sunbonnet, D.....2 reels
- 12-11. The Bold Bandit and the Rah Rah Boys, C.....1 reel The Invisible Power, Special, D.....4 reels
- 12-12. The Flying Freight's Captive, The Hazards of Helen, D.....1 reel
- 12-14. The Smugglers of Lone Isle, D.....2 reels
- 12-15. Cupid Backs the Winners, C.....1 reel
- 12-16. The Hate That Withers, D.....2 reels The School for Scandal, D.....4 reels
- 12-18. Through the Keyhole, C.....1 reel
- 12-19. The Black Diamond Express, Hazards of Helen, D.....1 reel
- 12-21. The Mayor's Secretary, Alice Joyce Series, D.....2000
- 12-22. The Winning Whiskers, C.....1000
- 12-23. The Fatal Opal, D.....2000
- 12-25. The Reformation of Ham, C.....1000
- 12-26. The Escape on the Limited, D.....1000
- 12-28. The Black Sheep, D.....2000
- 12-29. Love, Oil and Grease, C.....1000
- 12-30. The Derelict, D.....2000

LUBIN

- 12-3. The Grip of the Past, D.....2000
- 12-4. A Believer in Dreams, D.....1000
- 12-5. Brown's Cook, C.....400 He Wanted His Pants, C.....600
- 12-7. The Beloved Adventurer, Series No. 13, D.....1000
- 12-8. He Made His Mark, C.....400 Dob's at the Shore, C.....600

RELEASE DAYS

GENERAL FILM PROGRAM

- Monday—Biograph, Edison, Essanay, Hearst-Selig News Pictorial, Kalem, Selig, Vitagraph.
- Tuesday—Biograph, Edison, Essanay, Lubin, Selig, Vitagraph.
- Wednesday—Edison, Essanay, Kalem, Lubin, Selig, Vitagraph.
- Thursday—Biograph, Essanay, Hearst-Selig News Pictorial, Lubin, Mina, Selig, Vitagraph.
- Friday—Biograph, Edison, Essanay, Kalem, Selig, Lubin, Vitagraph.
- Saturday—Biograph, Edison, Essanay, Kalem, Lubin, Vitagraph, Selig.

UNIVERSAL PROGRAM

- Monday—Victor, Imp, Powers.
- Tuesday—Gold Seal, Crystal, Nestor.
- Wednesday—Nestor, Joker, Eclair.
- Thursday—Imp, Rex, Frontier, Sterling, Animated Weekly.
- Friday—Nestor, Powers, Victor.
- Saturday—Joker, Frontier, 101 Bison.
- Sunday—Rex, Crystal, Eclair, L-KO.

MUTUAL PROGRAM

- Monday—American, Keystone, Reliance.
- Tuesday—Beauty, Majestic, Thanouser.
- Wednesday—American, Broncho, Reliance.
- Thursday—Domino, Keystone, Mutual Weekly.
- Friday—Kay-Bee, Majestic, Princess.
- Saturday—Keystone, Reliance, Royal.
- Sunday—Majestic, Komic, Thanouser.

- 12-9. A Recent Confederate Victory, D...2000
- 12-10. The Man From the Sea, D.....2000
- 12-11. On Moonshine Mountain, D.....1,000
- 12-12. Sam and the Bully, C.....400 The Fresh Air Cure, C.....600
- 12-14. The Beloved Adventurer, No. 14, D.....1000
- 12-15. It Lured Hubby, C.....400 Weary Willie's Rags, C.....600
- 12-16. The Bomb, D.....2000
- 12-17. When the Blind See, D.....2000
- 12-18. The Comedienne's Strategy, C.....1000
- 12-19. Who's Who? C.....400 Shall Curfew Ring To-Night? C.....600
- 12-21. The Beloved Adventurer, No. 15, D.....1000
- 12-22. His Suicide, C.....400 Flossie's Daring Loyalty, C.....600
- 12-23. The Single Act, D.....2000
- 12-24. A Soldier of Peace, D.....2000
- 12-25. The Lure of the Green Table, D.....1000
- 12-26. Brannigan's Band, C.....400 A Troublesome Cat, C.....600
- 12-28. Patsy Bolivar Series, No. L, Patsy at School, C.....1000
- 12-29. A Cowboy Pastime, C.....1000
- 12-30. The Intriguers, D.....2000
- 12-31. Fate and Fugitive, D.....2000

MINA

- 12-17. The Thrilling Adventures of Count Verance, C.....1000
- 12-24. A High Old Time, C.....1000
- 12-31. The Siege of Liege, C.....1000

SELIG

- 12-5. Her Sister, D.....1000
- 12-7. The Mystery of the Seven Chests, D.....2000
- 12-8. Saved by a Watch, D.....1000
- 12-9. The Abyss.....1000
- 12-11. One Kiss.....1000
- 12-12. The Soul Mate.....1000
- 12-14. The Lure of the Windigo.....2000
- 12-15. The Man From the East.....1025
- 12-16. The Test.....1000
- 12-18. The Tail of a Coat.....850
- 12-19. The Lady or the Tiger, D.....1000
- 12-21. Not Announced.
- 12-22. Wade Brent Pays, D.....1000
- 12-22. Hearst-Selig News Pictorial No. 83, N.....1000
- 12-23. One Traveler Returns.....1000
- 12-24. Hearst-Selig News Pictorial No. 84, N.....1000
- 12-25. Wife Yer Feet, C.....950
- 12-26. Between Matinee and Night.....1025
- 12-28. Not Announced.
- 12-29. Cactus Jake, Heart-Breaker, C.....1000
- 12-29. Hearst-Selig News Pictorial No. 85, N.....1000
- 12-30. The Old Letter, D.....1000
- 12-31. Hearst-Selig News Pictorial No. 86, N.....1000
- 1-1. The Champion Bear Slayer.....1000
- 1-2. Heart's Desire.....1000

VITAGRAPH

- 12-7. The Moonshine Maid and the Man, D.....1000
- 12-8. Sunshine and Shadows, D.....2000
- 12-9. The Athletic Family, C.....1000
- 12-10. Pure Gold, D.....1000
- 12-11. A Strand of Blond Hair, C.....1000
- 12-12. How to Do It and Why, or Cutey at College, C.....2000
- 12-14. The Greater Love, D.....1000
- 12-15. Out of the Past, D.....2000
- 12-16. The Egyptian Mummy, C.....1000
- 12-17. A Question of Clothes, C.....1000
- 12-18. Who Was Who in Hogg's Hollow, C.....1000
- 12-19. Mr. Santa Claus, C.....2000
- 12-21. Arthur Truman's Ward, D.....1000
- 12-22. By the Governor's Order, D.....2000
- 12-23. The Professor's Romance, C.....1000
- 12-24. The Knight Before Christmas, D.....1000
- 12-25. Sweeney's Christmas Bird, C.....1000
- 12-26. An Affair for the Police, C.....2000
- 12-28. The Product, D.....1000
- 12-29. The Plot, D.....2000
- 12-30. Forcing Dad's Consent, C.....1000
- 12-31. Love Will Out, C.....1000

UNIVERSAL PROGRAM

ANIMATED WEEKLY

- 12-9. Weekly No. 144, N.....1 reel
- 12-16. Weekly No. 145, N.....1000
- 12-23. Weekly No. 146, N.....1000

101 BISON

- 12-19. The Christmas Spirit, D.....2000
- 12-26. The Law of the Range, D.....3000
- 1-2. In Jungle Wilds, D.....2000

CRYSTAL

- 11-24. Sammie's Vacation, C.....1000
- 12-1. Charlie Woos Vivian, and The Barber Shop Feud; split reel..... 1000
- 12-8. Vivian's Cookies, and Whose Baby, C., split reel..... 1000
- 12-15. Such a Mistake, and The Glass Pistol, split reel.....1000
- 12-22. Vivian's Beauty, C.....1000

ECLAIR

- 12-6. The Higher Impulse, D.....1000
- 12-9. For the Mastery of the World, D...3 reels
- 12-13. The Mountain Traitor, D.....1 reel
- 12-16. A Game of Wits, D.....2000
- 12-23. The Fortunes of Margaret, D.....2000
- 12-27. For the Defence, D.....1000
- 12-30. Within an Inch of His Life, D.....2000

FRONTIER

- 11-21. A Relic of Olden Days..... 1000
- 12-5. The Circle of Gold, D.....1000
- 12-12. Her Higher Ambition, D.....1 reel

NOTICE

Commencing on December 17th and continuing every Thursday thereafter, the regular licensed program will include a new one reel comedy of unusual merit.

Public demand for "funny pictures" is so overwhelming that one reel comedies have become a vital requisite to every daily program.

Exhibitors find it difficult—in many cases impossible—to secure **consistently good** comedies, and it is to meet precisely this condition that MinA Films have been devised.

They are the result of long, special study and practical test by one of the oldest and most successful manufacturers in the industry. MinA Films are recommended for your immediate consideration. Through all licensed exchanges and branches of the

General Film Co.

PA

Mr. Exhibitor, here is the fattest pot of gold you ever

THE EXPLOITS

The biggest and best serial yet. To be released

Played by a truly remarkable

ARNOLD DALY

and directed by Leopold Whar
the WHART

Written by Arthur B. Reeve, the novelist and creator of the collaboration with Charles L. Goddard, the famous playwright, suspense that rare scientific knowledge united with the most

THE WIDEST

will be given ELAINE since the stories of the exploits will appear American, Chicago Examiner, San Francisco Examiner, and Los other leading papers in every city in the country.

Every one will read THE EXPLOITS OF ELA

MR. EXHIBITOR: THIS WILL BE THE BIGGEST MONEY GETTER OF THE DE

ECLECTIC FEATURE FILM

Atlanta61 Walton St.
Dallas202 Andrews Bldg.
Chicago.....5 So. Wabash Ave.
Minneapolis109 Kasota Bldg.
New York115 E. 23d St.

Boston3 Tremont Row
Los Angeles114 E. 7th St.
St. Louis.....3210 Locust St.
San Francisco.....67 Turk St.
Syracuse.....214 E. Fayette St.
Pittsburgh715 Liberty Ave.

ECLECTIC FILM COMPANY, 110

THE

saw and it isn't at the foot of a rainbow either. It's

TS OF ELAINE

two reels every Monday beginning December 28th

rkable cast, headed by

and **PEARL WHITE**

ton, famous as the producer of
ON pictures

famous scientific detective character of "Craig Kennedy," in this great serial will bring into motion pictures all the thrills and able literary talent can give.

PUBLICITY

as released in the New York American, Boston American, Atlanta Angeles Examiner, with their millions of readers, as well as in

INE and every one will want to see the pictures.

GADE. WIRE OR WRITE OUR NEAREST EXCHANGE AT ONCE FOR BOOKINGS.

EXCHANGES FOR YOUR USE.

Cincinnati217 E. 5th St.
Cleveland622 Prospect Ave., S. E.
Portland392 Burnside Ave.
Philadelphia1235 Vine St.
New Orleans910 Gravier St.
Washington7th & E. Sts., N. W.

Kansas City928 Main St.
Denver16th & Larimer Sts.
Omaha1312 Farnam St.
Seattle810 Third Ave.
Salt Lake City68 So. Main St.

West 40th Street, New York, N. Y.



— PATHÉ —

There is many a person who has learned
the motion picture habit through seeing

THE PATHÉ NEWS

Why? Because it's always interesting,
always educational, and always up to
the minute.

That's why it is always profitable to the
exhibitor.

Now issued twice a week and may be
booked through the Eclectic Feature Film
Exchanges in all the principal cities of
the United States.

THE ECLECTIC



FILM COMPANY

110 WEST 40th STREET

NEW YORK, N. Y.

RELEASE DATES FOR READY REFERENCE — Continued

GOLD SEAL

- 12— 1. Called Back, D.....4000
- 12— 8. The District Attorney's Brother, D.....2 reels
- 12—15. The Ghost of Smiling Jim, D.....2000
- 12—22. The Call of the Waves, D.....2000
- 12—29. A Study in Scarlet, D.....2000

IMP

- 11—19. The Universal Boy in "Cupid and the Fishes"
- 11—23. His Gratitude, Mary Pickford, Reissue, D.....1000
- 11—26. Human Hearts, D.....3000
- 11—30. The Coward, D.....2000
- 12— 3. The Young Philanthropist, D.....1000
- 12— 7. The Outcome, Mary Pickford Reissue, D.....1 reel
- 12—10. Three Men Who Knew, D.....2 reels
- 12—14. The Mill Stream, D.....2 reels
- 12—17. Within the Gates of Paradise, Christmas Drama, D.....1000
- 12—21. In Sunny Spain, Mary Pickford Reissue, C.....1000
- 12—28. The Submarine Spy, D.....2000

JOKER

- 12— 2. The Wise Guys, C., and The Ascension of Theschyng Platt, Switzerland.....1000
- 12— 5. A Dream of a Painting, and The Porpoise Fisheries, E., split reel.....1000
- 12— 9. The Genii of the Vase, and Alaska, E., split reel.....1000
- 12—12. Love Disguised, and Building a Locomotive, E., split reel.....1000
- 12—16. How Father Won Out, and The Advent of the Ingrar Neilson, D.....2000
- 12—19. His Doctor's Orders, C.....1000
- 12—23. Love and Spirits, C.....1000
- 12—26. Christmas Festivities, C.....1000

L-KO

- 12—13. The Rural Demons, C.....1 reel
- 12—20. The Baron's Bear Escape, C.....1000
- 12—27. The Manicure Girl, C.....1000

NESTOR

- 11— 6. Those Were the Happy Days, C.....2000
- 11—10. The Two Thieves, D.....1000
- 11—13. When the Girls Were Shanghaied, C.....1000
- 11—20. When Their Brides Got Mixed, C.....1000
- 11—24. As We Journey Through Life, D.....1000
- 11—28. The Widows Last, D.....1 reel
- 12—11. Their Ups and Downs, C.....1 reel
- 12—15. The Boy Mayor, D.....1000
- 12—22. For I Have Toiled, D.....1000
- 12—25. Who Stole the Bridegroom? C.....1000

NESTOR COMEDY

- 12—18. His Dog Gone Luck, and Here and There in Japan with Homer Croy, C.....1000

POWERS

- 11—20. A Scenario Editor's Dream, C.....1000
- 11—27. Sissy Dobbins, Oil Magnate, D.....1000
- 12— 4. The Heart of a Magdalene, D.....1000
- 12—11. Adventures of the Nimble Dollar, D.....1 reel
- 12—25. Hunting in Crazyland, Cart., and The Japanese Silk Industry, E.....Split reel

REX

- 11—15. The Chorus Girl's Thanksgiving, D.....2000
- 11—19. His Uncle's Will, D.....2000
- 11—22. Traffic in Babes, C.....2000
- 11—26. Slow, but Sure, C.....2000
- 11—29. Lights and Shadows, D.....2000
- 12— 3. The Mystery of the Sea View Hotel, D.....2000
- 12— 6. The Lion, the Lamb and the Man, D.....2000
- 12—13. A Night of Thrills, D.....2 reels
- 12—17. Ambition, D.....2000
- 12—20. A Page from Life, D.....2000
- 12—24. The Big Sister's Christmas, D.....2000
- 12—27. Her Escape, D.....2000

STERLING

- 12—17. The Fatal Hansom, C.....1000
- 12—21. Carmen's Romance, C.....1000
- 12—24. Innocent Dad, C.....1000

UNIVERSAL IKE

- 10— 6. The Neglected Wife.....1000
- 10—13. Mary Green's Husband, and Educational, C.....1000
- 10—13. Mary Green's Husband, and The Monkey Cabaret, C., split reel....1000

VICTOR

- 11—30. A Lonely Salvation, Mary Fuller, D.....1000
- 12— 4. Father Buys a Bale, C.....1000
- 12— 7. Terence O'Rourke—The Inn of the Winged Gods, D.....2000
- 12—11. The Little Gray House, D.....2 reels
- 12—14. The Wayward Son, D.....1000
- 12—18. Mary Fuller, in Heart of the Hills, D.....3000
- 12—21. Terence O'Rourke, "The King and The Man," D.....2000
- 12—25. The Accusation, D.....2000

MUTUAL FILM PROGRAM

AMERICAN

- 12— 7. Out of the Darkness, D.....2000
- 12— 9. The Girl in Question, D.....1000
- 12—14. In Tune, D.....2000
- 12—16. The Silent Way, D.....1000
- 12—18. Trapped by a Heliograph, D.....1000
- 12—21. The Sower Reaps, D.....2000
- 12—23. The Tin Can Shack, D.....1000
- 12—28. When a Woman Waits, D.....2000
- 12—30. The Unseen Vengeance, D.....1000

BEAUTY

- 12— 1. Cupid and a Dress Coat, C.....1000
- 12— 8. Limping Into Happiness, C.....1000
- 12—15. Her Younger Sister, D.....1000
- 12—22. Brass Buttons, C.....1000
- 12—29. Love Knows No Law, D.....1000

BRONCHO

- 12— 9. The City of Darkness.....2000
- 12—16. The Panther.....1000
- 12—28. The Passing of Two Gun Hicks.....1000
- 12—30.—Face on the Ceiling, D.....2000

DOMINO

- 11—26. The Mills of the Gods.....2000
- 12— 3. The Vigil.....2000
- 12—10. Not of the Flock.....2000
- 12—17. The Political Feud.....2000
- 12—24. The Last of the Line, D.....2000
- 12—31. Flower in the Desert, D.....2000

KAY-BEE

- 11—20. The Master of the House.....2000
- 11—27. A Crook's Sweetheart.....2000
- 12— 4. Mother of the Shadows.....2000
- 12—11. Fortunes of War.....2000
- 12—18. The Game of Life, D.....2000
- 12—25. In the Sage Bush Country, D.....2000

KEYSTONE

- 10—26. Shot in the Excitement, C.....1000
- 10—26. Dough and Dynamite, C.....2000
- 10—29. Gentlemen of Nerve, C.....1000
- 10—31. Cursed by His Beauty, C.....1000
- 11— 2. Lovers' Post Office, C.....1000
- 11— 5. Curses They Remark'd, C.....1000
- 11— 7. His Musical Career, C.....1000
- 11— 9. His Trysting Places, C.....2000
- 11—12. An Incomplete Hero, C.....1000
- 11—14. How Heroes Are Made, C.....1000
- 11—16. Fatty's Jonah Day, C.....1000
- 11—19. The Noise of Bombs, C.....1 reel
- 11—21. Fatty's Wine Party, C.....1 reel
- 11—23. His Taking Ways, C.....1 reel
- 11—23. The Sea Nymphs, C., special.....1 reel
- 11—26. His Halted Career, C.....1 reel
- 11—28. Among the Mourners, C.....1 reel
- 11—30. Leading Lizzie Astray, C.....1 reel
- 12— 3. Shotguns That Kick, C.....1 reel
- 12— 5. Getting Acquainted, C.....1 reel
- 12— 7. His Pre-Historic Past, special.....2 reels
- 12— 7. Other People's Business, C.....1000
- 12—10. The Plumber, C.....1 reel
- 12—12. Ambrosio's First Falsehood, C.....1000
- 12—14. Fatty's Magic Pants, C.....1000
- 12—17. Hogan's Annual Spee, C.....1000
- 12—21. Fatty and Minnie He-Haw (Special).....2000

KOMIC

- 11—29. A Corner in Hats.....1000
- 12— 6. Bill No. 12.....1000
- 12—13. The Housebreakers.....1000
- 12—20. Bill and Ethel at the Ball (No. 13).....1000
- 12—27. Love and Business.....1000
- 1— 3. A Flurry in Art.....1000

MAJESTIC

- 11—22. The Saving Grace.....2000
- 11—24. Another Chance.....2000
- 11—29. The Sisters.....2000
- 12— 1. The Old Good for Nothing.....1000
- 12— 6. A Question of Courage.....1000
- 12— 8. Her Brave Hero.....1000
- 12—11. In Wildman's Land.....1000
- 12—13. The Old Maid, D.....2000
- 12—15. At Dawn.....2000
- 12—20. In Fear of His Past.....2000
- 12—22. The Better Way.....2000
- 12—27. How Hazel Got Even.....2000
- 12—29. His Lesson.....2000

MUTUAL WEEKLY

- 11— 3. No. 97.....1000
- 11—10. No. 98.....1000
- 11—17. No. 99, N.....1000
- 11—26. No. 100, N.....1000
- 12— 3. Weekly, No. 101, N.....1000
- 12—10. No. 102.....1000
- 12—17. No. 103, N.....1000
- 12—24. No. 104, N.....1000
- 12—31. No. 105, N.....1000

PRINCESS

- 11—20. The Bad Mistake.....1000
- 11—27. The Wild, Woolly West.....1000
- 12— 4. The Creator of Hunger.....1000
- 12—11. In the Conservatory, D.....1000
- 12—18. Shadows and Sunshine, D.....1000
- 12—25. When Fate Rebelled, D.....1000

RELIANCE

- 11—21. His Responsibility.....2000
- 11—23. Our Mutual Girl No. 45.....2000
- 11—25. They Never Knew.....2000
- 11—27. The Hop Smugglers.....2000
- 11—28. The Kafir's Skull.....2000
- 11—30. Our Mutual Girl No. 46.....2000
- 12— 2. The Lucky Shot.....2000
- 12— 5. Who Shot Bud?.....2000
- 12— 7. Our Mutual Girl, No. 47.....2000
- 12— 9. Forest Thieves.....2000
- 12—12. On the Ledge.....2000
- 12—14. Our Mutual Girl, No. 48.....2000
- 12—16. The Joke on Yelltown.....2000
- 12—19. The Beat of the Year.....2000
- 12—21. Our Mutual Girl, No. 49.....2000
- 12—23. A Lucky Disappointment.....2000
- 12—25. Bobby's Medal.....2000
- 12—26.—The Exposure.....2000
- 12—28. Our Mutual Girl, No. 50.....2000
- 12—30. The Navajo Maiden.....2000

ROYAL

- 11—21. Love Finds a Way.....1000
- 11—28. Before and After.....1000
- 12— 5. Sherman Was Right—It's Very Trying.....1000
- 12—12. Percy the Milliner, C.....1000
- 12—19. Two Kisses.....1000
- 12—26. Her Mother's Voice.....1000
- 1— 2. Putting It Over, C.....1000
- 1— 9. Married by Installment, C.....1000

THANHOUSER

- 10—27. A Madonna of the Poor.....2000
- 11— 1. Shep's Race with Death.....2000
- 11— 3. The Turning of the Road.....2000
- 11— 8. Keeping a Husband.....2000
- 11—10. The Terror of Anger.....2000
- 11—13. The Chasm.....2000
- 11—15. The Man with the Hoe.....2000
- 11—17. Pawns of Fate.....2000
- 11—22. A Messenger of Gladness.....2000
- 11—24. Mrs. Van Ruyter's Stratagem.....2000
- 11—29. A Denver Romance.....2000
- 12— 1. The Center of the Web.....2 R.
- 12— 4. Naidra, the Dream Woman.....2 R.
- 12— 6. The Amateur Detective.....2 R.
- 12— 8. The Reader of Minds.....2 R.
- 12—13. When East Meets West.....2 R.
- 12—15. The Barrier of Flames.....2 R.
- 12—20. Sid Nee's Finish.....2000
- 12—22. Under False Colors.....2000
- 12—27. A Hatful of Trouble.....2000
- 12—29. Lucy's Elopement.....2000

RELEASE DATES FOR READY REFERENCE — Continued

FEATURE RELEASES

ALCO FILM CORPORATION

ALL STAR

- 10— 5. The Nightingale, D.....5 parts
- 10—19. Shore Acres.....5 parts
- Nov. 23. Education of Mr. Pipp.....4 parts
- Dec. 28. Garden of Lies.....

LIFE PHOTO FILM CORPORATION

- Dec. 7. Springtime.....
- The Avalanche.....

POPULAR PLAYS AND PLAYERS

- 10—12. The Ragged Earl, D.....
- 10—26. Michael Strogoff, D.....5 parts
- 12—21. The Tigress.....

B. A. ROLFE PHOTO PRODUCTIONS

- Nov. Rip Van Winkle.....5 parts
- The Three of Us.....

TIFFANY MOTION PICTURE CORP.

- Heart of Maryland.....

ALLIANCE FILMS CORPORATION

COSMOS FEATURE FILM CORPORATION

- Lena Rivers, D.....5 parts
- Nov. 30. Hearts and Flowers, D.....5 parts
- The Little Girl That He Forgot..

EXCELSIOR FEATURE FILM CO.

- The Path Forbidden.....
- 11—23. When Fate Leads Trump.....
- The Under Trail.....

FAVORITE PLAYERS

- The Key to Yesterday.....5 parts
- 11—16. The Man Who Could Not Lose... 2 parts
- The Last Chapter.....

MASTERPIECE FILM COMPANY

- 11— 9. The Hoosier Schoolmaster.....5 parts
- The Truth Wagon.....

OZ FILM COMPANY

- 12— 7. The Last Egyptian.....5 parts

SELECT PHOTO-PLAY PRODUCING CO.

- 10—26. At the Old Cross Roads, D.....5 parts

BOX OFFICE ATTRACTION CO.

BALBOA

- Nov. Little Jack.....3 reels
- Nov. 10. Message of the Mind.....3 reels
- Nov. 17. The Call of the Heart.....2 reels

NEMO

- Nov. Bitter Sweets.....3 reels

WHITE STAR

- Nov. The Mask.....2 reels
- Nov. 10. To Love and to Hold.....2 reels
- Nov. 17. Vengeance of the Flames.....3 reels

BOX OFFICE ATTRACTIONS—Special Features

- 11— 9. Life's Shop Window.....
- 11—19. The Walls of Jericho.....
- 11—29. The Thief.....

BLINKHORN PHOTOPLAYS

- Nov. The Witness Invisible, D.....3 reels
- Nov. The Aviator Traitor, D.....3 reels

COSMOFOTOFILM CORPORATION

- Nov. For Home and Country.....2 parts
- Nov. She Stoops to Conquer.....4 parts
- Nov. Called Back.....4 parts
- Nov. Beauty and the Barge.....4 parts

ECLECTIC FILM COMPANY

- Nov. Perils of Pauline, No. 19, D.....2 parts
- Nov. Jolts of Jealousy, C.....1 part
- Nov. Thirty Years of a Gambler's Life, D.3 parts
- Nov. Pathé Daily News, No. 82, N.....1 part
- Nov. The Stolen Birthright, D.....3 parts
- Nov. Pathé Daily News, No. 83, N.....1 part
- Dec. The Silent Accuser, D.....3000
- Dec. A Temperamental Whiffles, C.....2000
- Dec. The Quality of Mercy, D.....2000
- Dec. When Wealth Aspires.....4000
- Dec. Star of Genius.....3000

ITALA FILM COMPANY

- Nov. Cabiria.....
- Nov. Treasure of the Louzats.....4 parts
- Nov. Jules Porel—Serpent.....3 parts

KINETOPHOTE CORPORATION

- 10—26. Markia, or The Destruction of Carthage.....5 reels
- 11— 2. Born Again.....5 reels
- 11—16. The Coming Power.....4 reels
- 11—23. The Spirit of the Poppy.....6 reels
- 12— 7. The Span of Life.....5 reels
- 12—21. The Little Jewess.....4 reels

OZ FILM COMPANY

- Oct. Patchwork Girl of Oz.....5 parts

CONTINENTAL FEATURES

KAY BEE

- The Battle of Gettysburg.....

KEYSTONE

- Zu Zu, the Band Leader.....

MAJESTIC

- Ruy Blas.....

MUTUAL SPECIAL

- Mexican War Pictures.....
- Seeing South America with Roosevelt

NEW MAJESTIC

- Sapho.....

N. Y. MOTION PICTURE

- The Wrath of the Gods.....

R & M

- The Great Leap.....
- The Gangsters of New York.....
- The Battle of the Sexes.....
- The Floor Above.....
- The Dishonored Medal.....
- The Mountain Rat.....
- Home, Sweet Home.....
- The Avenging Conscience.....

THANHOUSER

- Moths.....
- Robin Hood.....
- A Legend of Provence.....
- Frou-Frou.....
- Joseph In the Land of Egypt.....
- Cardinal Richelieu's Ward.....
- Dope.....

PARAMOUNT PICTURES

BOSWORTH

- 11—23. The Country Mouse, C-D.....4 parts

SMALLEYS

- 12—17. False Colors, D.....5 parts
- 1—14. Aurora Leigh.....5 reels

COSMOFOTOFILM

- Dec. The Two Columbines.....2 parts
- Dec. A Christmas Carol.....1 reel

FAMOUS PLAYERS

- 12—10. The Conspiracy.....4 reels
- 12—14. The Crucible.....5 reels
- 12—21. The Sign of the Cross.....5 reels
- 12—28. Cinderella.....5 reels
- 12—31. The Million.....4 reels
- 1—11. The Dancing Girl.....5 reels
- 1—18. The Morals of Marcus.....5 reels

JESSE LASKY COMPANY

- 12— 7. Ghostbreaker, D.....5 parts
- 1—21. Young Romance.....5 reels
- 1—25. The Goose Girl.....5 reels

LASKY-BELASCO

- 1— 4. The Girl of the Golden West.....5 reels

LASKY-LIEBLER

- 1—28. After Five.....5 reels

PICTURE PLAYHOUSE FILM COMPANY, INC.

- 12— 2. Convict 555.....
- 12—10. Partners.....

SAWYER, Inc.

- Doc.....4 reels
- The Envoy Extraordinary.....5 reels
- Thais.....4 reels
- The Fatal Night.....4 reels
- The Virgin of the Rocks.....4 reels
- Loves and Adventures of Shakespeare.....6 reels
- Saved by the Boys in Blue.....3 reels
- King of the Bowery.....4 reels
- Mona Darkfeather, Series.....2 reels
- Nell of the Circus, Cecil Spooner.....4 reels
- Spirit of the Conqueror.....5 reels
- Catch of the Sword.....3 reels
- Without Hope.....4 reels
- As a Man Sows.....5 reels
- A Factory Magdalen.....5 reels
- The Lady of Lyons.....5 reels

UNITED FILM SERVICE

WARNER'S FEATURES, INC.

EVANS

- 11—27. Pagliacci, D.....2000
- 12— 7. Everyone, D.....2000

FEATURES IDEAL

- 11— 9. The Last Chord, D.....3000
- 11—16. The Nihilist's Daughter, D.....3000
- 11—25. Zandori's Secret, D.....3000
- 12— 1. The Wolf's Prey, D.....3000

GAUNTIER

- 11—30. The Little Rebel, D.....2000

HUMANOLOGY FILM PRODUCING CO.

- 12— 7. The Price He Paid, D.....5000

LUNA

- 11—12. Reuben's Busy Day, C.....1 reel
- 11—19. Sage Brush Leading Lady, C.....1 reel
- 12—26. Soul Mates, C.....1000
- 12— 2. Mountain Goat, C.....1000

MILLER BROTHERS

- 11—16. Rainbow's End, D.....3000
- 11—23. Mexican Hatred, D.....3000
- 11—30. Harvest Romance, D.....1000
- 12— 7. Romance of Coyote Hill, D.....1000

MITTENTHAL

- 11— 8. The Terror of a Great City.....3 reels

PREMIER

- 11—14. Gypsy's Warning, D.....1 reel
- 11—21. Bandit of Devil's Gap, D.....1 reel
- The Prospector's Warning.....1 reel
- 11—28. As a Man Chooses, D.....1 reel
- 12— 5. Prospector's Warning, D.....1 reel
- 12— 5. Stung by a Bee, C.....1 reel

SAVOIA

- 11— 8. The Last Chord.....3 reels

STARLIGHT

- 11—10. The Villain Still Pursued Her, C.....1 reel
- 11—17. Noisy Neighbors, C.....1 reel
- 11—23. Help! Murder! Police! C.....1 reel
- 12— 1. Sadie as She Never Was, C.....1 reel

SUPERBA

- 11— 8. Prince Charlie, C.....1 reel
- 11—15. Taste of High Life, C.....1 reel
- 11—23. Dr. Jekyll and Mr. Hyde, D.....1 reel
- 11—29. Camille as She Never Was, C.....1 reel

WARNER'S FEATURES

- Nov. Even Unto Death, D.....
- Nov. The Serum of Reason.....4 parts

WORLD FILM CORPORATION

- 10—26. When Broadway Was a Trail.....5 parts
- 11— 2. Across the Pacific.....5 parts
- 11— 9. The Wishing Ring.....5 parts
- 11—16. One of Millions.....4 parts
- 11—23. Lola.....5 parts
- 11—30. The Dancer and the King.....5 parts
- 12— 7. The Seats of the Mighty.....
- 12—14. The Marked Woman.....
- 12—21. As Ye Sow.....
- 12—28. The Pit.....
- 1—11. Wildfire.....

CALIFORNIA MOTION PICTURE CORP.

- 11— 2. Salomy Jane.....5 parts
- 1— 4. Mrs. Wiggs of the Cabbage Patch.....
- 1—18. Mignon.....4 parts
- Lily of Poverty Flats.....
- Salvation Nell.....

MISS RUTH ROLAND

“THE FAMOUS KALEM GIRL”

Has Been Engaged by the Balboa Company

Because she is the best and most favorably known motion picture actress in the United States today—

She has scored big in dramas and bigger still in comedies—

But she is not wedded to one or the other. On the contrary—

She is a versatile young woman whose talents are as brilliant as her beauty—

With the Balboa Company she will have an opportunity to utilize her versatility to its fullest extent.

At the start she will appear in a number of remarkable dramas, impersonating roles that demand a combination of all the wonderful ability she has displayed during her past four years with the Kalem Company.

Miss Roland is a real star with a personality that stands out vividly on the screen—

A personality that commands and holds attention while it pleases and thrills her audiences.

She has cultivated the art of motion picture expression to a high point of perfection.

Her performances are unvaryingly strong and she has established herself in the esteem of exhibitors everywhere.

The Balboa Company knows that her name is magnetic knows that those who release and play its productions will be gratified to learn that it has Ruth Roland—

And yet this was not the thought that influenced her engagement.

It is the ambition of the Balboa Company to make the best picture plays in the United States, and it is convinced that Miss Ruth Roland is a necessary element in the achievement of that worthy aim.

She was chosen because she represents the higher and more finished type of motion picture actress—because she is an exponent of the more refined school of dramatic expression as it relates to the science of cinematography.

The Balboa Company has faith in Miss Roland and is determined to furnish her with vehicles that will enable her to harmoniously blend her inherent powers over the possibilities of amusement loving humanity.

She is lavishly endowed with rare gifts—beauty, grace, charm and intelligence.

A mind naturally bright has been carefully trained to meet the loftier requirements of her profession—

And under the direction of the Balboa Company her aspirations will be encouraged.



MISS RUTH ROLAND

The Famous Kalem Girl, is now with the Balboa Company

She will be given ample latitude in which to demonstrate the fact that, great as she is, it is possible for her to become greater.

BALBOA AMUSEMENT PRODUCING CO.

H. M. HORKHEIMER
President and General Manager

E. D. HORKHEIMER
Secretary and Treasurer

“Makers of Pictures Beautiful”

Studios and Executive Offices
LONG BEACH, CALIFORNIA

INTERESTING FILM REVIEWS

(Continued from page 85.)

"The Plumber." (Keystone. Thurs., Dec. 10.)—The humor of this picture is not of a rapiere-quality, and might jar aesthetic souls, but the fact remains that it is sidesplittingly funny. The story concerns a plumber who comes to fix a leak in a water pipe, and in fixing it succeeds in filling the cellar with water, and then burning down the house. A perfect masterpiece of non-sense.

"In Wildman's Land." (Majestic. Fri., Dec. 11.)—Whether this picture will strike the spectators as humorous or pathetic will depend entirely on their attitude. The grotesque actions of some imaginary cave dwellers as seen in the modern woman's dream are in a great sense true to life and then again humorous. In her dream these prehistoric people capture the woman's child and kill her husband. Her awakening is totally unexpected, as we did not see her fall asleep. At any rate the picture is so far out of the ordinary that it will not fail to awaken interest and to create considerable comment.

"Percy the Milliner." (Royal. Sat., Dec. 12.)—This reel featuring Louis Simon totally misses its intended mark as a comedy. There will be a few laughs toward the end when the dupe of the picture is shut out on a balcony by the wife of the house, and is drenched with rain. The plot, however, is rather vague, and the actions of the players quite meaningless.

"The Panther." (Broncho. Two reels. Wed., Dec. 16.)—Probably Walter Edwards is one of the most capable character actors of the day. He has played many roles and appears to excellent advantage in all of them. In this picture he is burdened with the unpleasant part of a maliciously vile character. He has his mind set on procuring a certain girl as his wife, and treats her husband with unmerciful cruelty. Justice is finally meted out to him by an Indian, a great friend of the father of the girl, whom the factor killed. Louise Glaum is the girl and Frank Borzage her husband. The story is exceptionally strong, repellent at some moments, but altogether most entertaining.

"A Political Feud." (Domino. Two reels. Thurs., Dec. 17.)—A story built on the familiar plot of a life-long rivalry between a poor boy

and a rich one. Their trouble begins when they are children and continues through college and until the poor man defeats the other for the governorship of the state.

WARNER'S FEATURES

"Her Duplicate Husband." (Features Ideal. Three reels.)—This film was originally of greater length, and in its present state it bears the marks of cutting. The story is not very clear, due probably to this fact, and the sub-titles are slightly too long and complicated to be easily comprehended. The final situation, which, if handled in the correct manner, could have been made to appear powerful, is rather unconvincing. The photography throughout is good, the settings appropriate, and what few exteriors that appear are well chosen. Jean Brunt, an escaped convict, is made, in some miraculous manner, to appear as a count, who has previously died. He returns to the count's house, and, after straightening out various troubles which he had no hand in causing, enters upon a peaceful life. Later his mother dies, and his old housekeeper then tells him that she and no other knows that he is guilty of the crime for which Jean Brunt was imprisoned for, years ago. Brunt, alias the count, is in a quandary as to what he will do, but that night his mansion catches fire and he perishes in the flames.

"Puss in the Well." (Starlight.)—After warning her little daughter and her playmates to keep away from an old well, the mother falls asleep and dreams. In her dream the children enact a melodrama which will be apt to cause admiration for the child players, but few laughs.

"Dr. Killem's Dope." (Premier.)—Although the theme of this reel is quite familiar, it could have been made humorous if the director had developed it to a greater extent; as it is, the actions lag before the picture draws to a close. Dr. Killem brings some dope to a lazy town. The dope is guaranteed to cure any malady. Little else happens except that it smoothes down an old maid's temper, and her suitor is accepted.

"Her Birthday Present." (Premier.)—A fairly good dramatic number with Joe Franz, Fred Church and Edythe Sterling in the leading parts.

Joe accuses his rival of a murder which he did not commit, so that he is forced to flee. When Fred does not return the girl accepts Joe. Five years later, after Joe has become an habitual gambler, he plans to rob his own house. The same night Fred returns and attacks him. Joe is shot by the sheriff. "What might have been" if the other two had married is then shown.

"Two Smarties." (Superba.)—A flirtatious husband causes all the characters of this comedy to deceive each other. The cop is about the funniest character. Charlie De Forrest plays the leading part. The comedy moments that appear in this reel are not unusually great in number; those that do appear are of the rough variety.

"The Man in Skirts." (Superba.)—Charlie De Forrest appears as a tramp in this number, and enters the house of a henpecked husband whose place is being assumed by a friend who is in love with the man's wife. A few of the rough comedy moments may strike some as rather vulgar, although Charlie makes as much out of them as he can.

"The White Pirate." (Starlight.)—There are some humorous moments in this number which are unconventional and really funny. They present themselves when one gentleman is disporting himself at another's expense by causing him to believe that he is in a haunted house. The plot, too, is amusing and all in all the picture will afford good entertainment.

"The Chaser." (Luna. Split reel.)—On the same reel with "His Neighbor's Pants." Two tramps conceive the idea of falling down in front of a bar-room and then calling for a drink to be revived. But they meet with little success and get soundly beaten up a couple of times. This will amuse.

"His Neighbor's Pants." (Luna. Split reel.)—On the same reel with "The Chaser." A good comedy number, in which a clever bull dog causes all the trouble by bringing a pair of pants into his mistress' house. Her husband grows suspicious, and pursues a person into a closet, thinking that he has captured a man, but it turns out to be his mother-in-law, who after being so rudely treated refuses to leave her daughter any of her promised fortune.

LUBIN

LUBIN MASTERPIECES

Now Ready and About To Be Released
(Through the General Film Special Service)

EDWIN ARDEN

Drama By Edwin Arden IN "EAGLE'S NEST" Direction—Romaine Fielding

RAYMOND HITCHCOCK

(The Funniest Man on the Stage) IN "THE RINGTAILED RHINOCEROS" Comedy Drama By Lawrence S. McCloskey Direction—George W. Terwilliger

"THE WHITE MASK"

Drama FEATURING LILIE LESLIE By Clay M. Greene Direction—Joseph W. Smiley

ROSE COGLAN

And ETHEL CLAYTON in "THE SPORTING DUCHESS" Comedy Drama By Cecil Raleigh Direction—Barry O'Neil

"THE COLLEGE WIDOW"

Featuring Ethel Clayton and George Soule Spencer Comedy Drama By George Ade Direction—Barry O'Neil

"THE VALLEY OF LOST HOPE"

Drama By Shannon Fife Direction—Romaine Fielding

NOW SHOWING WITH SUCCESS (BY ARRANGEMENT) WITH FRED MACE

EVELYN NESBIT THAW and her son **RUSSELL WILLIAM THAW** in "THREADS OF DESTINY" Drama By William H. Clifford Direction Joseph W. Smiley

SIX REGULAR RELEASES EACH WEEK

SPECIAL ONE, THREE AND SIX SHEETS



"THE BELOVED ADVENTURER," Fourteenth of Series, "A Perilous Passage" { Drama..... Monday,	December 14th
"IT CURED HUBBY" { Split Reel Comedy..... Tuesday,	December 15th
"WEARY WILLIE'S RAGS" { Split Reel Comedy..... Tuesday,	December 15th
"THE BOMB"—Two Reel Drama..... Wednesday,	December 16th
"WHEN THE BLIND SEE"—Two Reel Drama..... Thursday,	December 17th
"THE COMEDIENNE'S STRATEGY"—Comedy..... Friday,	December 18th
"WHO'S WHO" { Split Reel Comedy..... Saturday,	December 19th
"SHALL CURFEW RING TONIGHT?" { Split Reel Comedy..... Saturday,	December 19th

Lubin Manufacturing Company, Philadelphia, Pa.

Chicago Office: 154 West Lake Street

"THE RESCUE OF THE STEFANSSON ARCTIC EXPEDITION"

(Sunset Film—Eight Reels)

REVIEWED BY PETER MILNE

ALTHOUGH all of us have heard more or less about life in Alaska, and northeastern Siberia, very few of us have ever had the pleasure of visiting these countries and studying the habits of the natives. When these educational and interest-



THE LAST PICTURE OF STEFANSSON

ing facts are cast upon the screen, combined with a story, or rather an event, which is practically sure to become a tragedy, the result is an educational and historic production of almost priceless worth.

As the title implies, the picture concerns the rescue party which went in search of the Stefansson exploring party, the leader of which has never been heard from since he set out to reach the North Pole in the early part of last summer. We are even furnished with scenes in which Stefansson, himself the central figure, scenes which cannot possibly pass without causing an unusually big impression, as it is now almost certain that the brave explorer is dead.

The rescue party sent out to search for the members of the fatal exploring party were accompanied by a camera man in the employ of the Sunset Film Company. He has secured remarkable pictures, concerning both the tragic occurrence and incidentally scenes in the far off countries which we seldom are fortunate enough to hear of.

That the camera man, F. L. Granville, knew his business

from A to Z is so evident as to warrant the heartiest praise and thanks for his excellently-attained efforts. The photography that marks his work is of an unequalled variety, and the film has been aptly tinted to obliterate the eye strain that would surely result if the snow had been left in its natural whiteness in all the scenes.

Some of the views obtained in the film ought to be described at length, but it is enough to say that they are par excellence. They can only be mentioned. Huge herds of Alaskan and Siberian deer have been caught by the camera; polar bears and comfortable appearing bruins; herds, if they may be termed that, of huge walruses, which the camera has come upon with startling proximity; the harpooning and killing of whales and afterwards their dissection by the natives, besides hundreds of valuable skins of all varieties which will call forth cries of admiration from the feminine part of the audience, at least.

Besides these scenes, various types of Alaskan and Russian natives have been procured, posed in groups, for the most part. Throughout the picture some of the most beautiful scenes have been obtained, largely on the water. The cloud effect, long sought after by many a director, seems to be an easy thing to procure in the Far North as it is in evidence quite often.

In its class of pictures this one is truly one of the best. It is almost indescribable, and as is most always the case in scenic pictures, must be seen to be appreciated. If you are looking for an educational film, crammed full of the most entertaining and instructive scenes, combined with bits of the tragic story of the great Stefansson, these eight reels will suit the most fastidious, as well as please any audience.

TIME LIMIT EXTENDED ON WAR TAX PAYMENTS IN PITTSBURGH

THE time of paying the war tax in Pittsburgh was extended one day in order to give some of the exhibitors out of the city extra time to meet the requirements of the law.

Last Monday there was a crush of tax payers at the Federal building in Pittsburgh, and the clerks were not able to handle them fast enough. The office employees worked fast, but several hundred of the taxpayers appeared and tendered their money, and the result was that the office was so rushed that the clerks were not able to get the receipts made out in time to get through with the crowd.

It is said at the government building that many of the exhibitors failed to appear and pay their assessment, and they are now liable to a fine and imprisonment. The officers here are inclined to be lenient, and will make allowances in cases where it was impossible for the taxpayer to appear in the specified time. All, however, have been told to appear and prepare for the worst as the law is plain regarding the fine and increase in the taxation for delinquents.

REPRESENTATIVE SCENES FROM "THE PRICE HE PAID" (WARNER-HUMANOLGY FEATURE)



THE MODEL OF HIS DAYS OF WEALTH

PAINTING "THE OTHER WOMAN"

THE MODEL OF THE ARTIST'S DAYS OF STRUGGLE

VITAGRAPH

"THE GREATER LOVE", Drama Monday, Dec. 14th

For the happiness of the girl he loves, he departs from her life forever. It gives her freedom to marry another and forget his existence. DOROTHY KELLY, JAMES MORRISON and GEORGE COOPER are the principals.

"OUT OF THE PAST", Drama in Two Parts Tuesday, Dec. 15th

Past reminders haunt the happiness of the present. Like spectres they vanish from the sacredness of love and goodness. An all star cast.

"THE EGYPTIAN MUMMY", Comedy Wednesday, Dec. 16th

It shows itself to be very much alive and proves an excellent matchmaker. It puts life and action into everybody. It is not a "dead one." BILLY QUIRK, LEE BEGGS and CONSTANCE TALMADGE.

"A QUESTION OF CLOTHES", Comedy Thursday, Dec. 17th

True love isn't measured by a woman's dress. The young curate gives Madge up when she dons boy's clothes and she marries the other fellow who really loves her. NORMA TALMADGE and an all star cast.

"WHO'S WHO IN HOGGS HOLLOW", Comedy Friday, Dec. 18th

The automobilists find out, when Sheriff Hogg arrests them. Justice Hogg fines them and hotel proprietor Hogg bleeds them. Hogg is the whole thing. SIDNEY DREY as Hogg.

"MR. SANTA CLAUS", Drama in Two Parts Saturday Dec. 19th

Poor little Celeste and her mother do not expect him. He calls just the same, provides for a Merry Christmas and many more of the same kind. JAY DWIGGINS, MARY MAURICE and selected cast.

SIX A WEEK

"ARTHUR TRUMAN'S WARD," Drama.....MONDAY, DEC. 21

"BY THE GOVERNOR'S ORDER," Drama in Two Parts.

TUESDAY, DEC. 22

"THE PROFESSOR'S ROMANCE," Comedy.....WEDNESDAY, DEC. 23

"THE KNIGHT BEFORE CHRISTMAS," Comedy.....Drama.

THURSDAY, DEC. 24

"SWEENEY'S CHRISTMAS BIRD," Comedy.....FRIDAY, DEC. 25

"AN AFFAIR FOR THE POLICE," Two-Part Comedy.

SATURDAY, DEC. 26

VITAGRAPH ONE, THREE AND SIX SHEET POSTERS

The Vitagraph Company of America

East 15th St. and Locust Ave. Brooklyn, N. Y.

BROADWAY STAR FEATURES

RELEASED

A MILLION BID	5 PARTS	THE PAINTED WORLD	3 PARTS
GOODNESS GRACIOUS	3 PARTS	FLORIDA ENCHANTMENT	5 PARTS
MR. BARNES OF NEW YORK	3 PARTS	413	3 PARTS
LOVE, LUCK AND GASOLENE	6 PARTS	THE WIN(K)SOME WIDOW	4 PARTS
CAPTAIN ALVAREZ	3 PARTS	THE TANGLE	4 PARTS
SHADOWS OF THE PAST	6 PARTS	THE LOCKED DOOR	3 PARTS
BINGLES' MELODRAMA	3 PARTS	SYLVIA GRAY	4 PARTS
MY OFFICIAL WIFE	5 PARTS	THE LITTLE ANGEL	5 PARTS
UNCLE BILL	3 PARTS	OF CANYON CREEK	From Book

As Presented at the **VITAGRAPH THEATRE** New York City

COMING

TWO WOMEN	3 PARTS	C. O. D	4 PARTS
THE SAGE BRUSH GAL	3 PARTS		From Play
THE MAN BEHIND	4 PARTS	UNDERNEATH THE PAINT	3 PARTS
THE DOOR	From Book		

Produced by THE VITAGRAPH CO. OF AMERICA and Released Through

THE GENERAL FILM COMPANY'S SPECIAL SERVICE

By Arrangement With BROADWAY STAR FEATURE CO., Inc.

WARNING!

THE SELIG POLYSCOPE COMPANY is the sole owner of the world's photoplay rights of a certain drama, written by ELLA WHEELER WILCOX, and known to the public as

"MIZPAH"

In accordance with our rights, we hereby give warning that we will vigorously prosecute all persons exhibiting any photoplay bearing same title, whether story of such photoplay is similar to that of our property or not. The law is clearly defined that THE SELIG POLYSCOPE COMPANY only may use the title "MIZPAH" in connection with any dramatic or spectacular action in motion pictures of whatsoever nature.

THE SELIG POLYSCOPE COMPANY

CHICAGO, ILL. DEC. 5, 1914.

NATHAN BURKAN, Attorney
165 Broadway, New York City

VITAGRAPH

Get Wise to This

SPECIAL ARRANGEMENTS HAVE BEEN MADE WITH
THE BROADWAY STAR FEATURE CO. TO RELEASE

ALL 3 PART BROADWAY STAR FEATURES IN THE REGULAR GENERAL FILM SERVICE

EVERY TUESDAY OF EVERY WEEK
BEGINNING TUESDAY, JANUARY 5TH

The First Month

- "TWO WOMEN" Released Jan. 5th
- "THE SAGE BRUSH GAL" Released Jan. 12th
- "UNDERNEATH THE PAINT" Released Jan. 19th
NOW RUNNING AT THE VITAGRAPH THEATRE
- "THE EVIL MEN DO" Released Jan. 26th

ALL HAVE AND WILL HAVE THEIR FIRST SHOWING AT THE
VITAGRAPH THEATRE, N. Y. CITY, PROVING THEM

All Tested Triumphs All Instantaneous Irresistible Successes

The Broadway Star Features are replete with dramatic power and indomitable punch.
All the famous Vitagraph players appear in them. A regular FEATURE service every week.
There's a reason for the Vitagraph being where it is—at the top.

The Vitagraph Monday releases will be changed from a Drama to a Comedy. This makes three Vita-
graph Comedies each week—Monday, Wednesday and Friday.

On every Saturday of each week, a two-part Vitagraph Comedy or Drama will be released.

VITAGRAPH CO. OF AMERICA, BROOKLYN, N. Y.



Dan Mason as "The Widower"



Dan Mason as "Uncle Crusty"

Dan Mason in a New Kind of Edison Comedy

IF DAN MASON had lived in the days when gallants staked their marital fortunes and their lives on being able to make the beautiful princess smile despite her solemn vow never to do so again, he would have had a whole collection of beautiful princesses, for he is one of the gifted few who never fail to get a laugh. He is a master of all things comic, his ludicrous facial expressions and the laughter-provoking gestures are irresistibly clever. Be it a straight comedy part or a grotesque, clownish figure, Mr. Mason projects his personality into it—and it is a success.

It is difficult to think of a comedian taking his part seriously, yet that is, in fact, Mr. Mason's attitude toward his work. He makes a careful study of every part that he plays and determines exactly how the role is to be played. He experiments with his grease paints until he has found a make-up that suits his conception of the character and then he is the janitor, the clergyman, the henpecked husband, or whatever the part may be.

Dan Mason as the "WIDOWER" in "A DOUBLE ELOPEMENT"

The rapid action of this comedy, coupled with the splendid character impersonations throughout, gives it a charm all its own and will insure for it an enthusiastic reception.

Released December 2nd, 1914

Dan Mason as "UNCLE CRUSTY" in a play of the same name

In this excellent photoplay we see a crusty old man, annoyed by children, transformed into a liberal child-loving character. The situations are ludicrous, and the impersonation of the characters assumed capital.

To be Released in January, 1915

Some Forthcoming Edison Releases:

Friday, December 25th.	A Premature Compromise.....	Drama, 2000 ft.
Saturday, " 26th.	The Man Who Vanished.....	Drama, 1000 "
Monday, " 28th.	The Calico Cat	Comedy, 1000 "
Tuesday, " 29th.	The Lesson of the Flames.....	Drama, 1000 "
Wednesday, " 30th.	The Courtship of the Cooks.....	Farce Comedy, 1000 "

Order Edison Posters of the Morgan Lithograph Co., Cleveland, Ohio, direct.



THOMAS A. EDISON, Inc.
275 Lakeside Avenue
Orange, N. J.

MAKERS OF EDISON KINETOSCOPE, MODEL D.

FANTASMA—IS A GOLD MINE



Hanlon Bros.' Great Feast of Fun and Fairyland Beauty—More Gorgeous Than Ever

Featuring George Hanlon, Jr., as the Clown

Released Saturday, December 19th through the General Film Co., in 5 parts

Fantasma, the most famous spectacle and the greatest moneymaker ever produced by the celebrated Hanlon Brothers, makes even a better fantasy in the film than on the stage where it has been popular for 30 years. George Hanlon, of the famed family of clown and pantomimists, appears in his original role of Pico, the drollest clown that was ever created. W. T. Carleton, the greatest Mephisto on the American stage, plays Zamaliel, prince of Darkness and Evil, while George Schrode and William Ruge, celebrated in these parts, make the Imps a devilish pair. The lovely Marie La Manna graces the Princess role with fairylike charm.

For over thirty years Fantasma has fascinated all from the child to the grandfather with its wonderful blending of amusement and beauty, romance and fairyfolk, visualized as only the fancy of youth can picture.

The originators of this famous spectacle, Hanlon Brothers, were known over two continents as the greatest inventors of stage tricks, effects and illusions which they always used with bewildering beauty of effect. The Edison Company has preserved all the charm and atmosphere of the original production, adding new and surprisingly beautiful photographic effects never possible on the stage. Funniness, mystery, weird experiences, mystifying illusions and an unending panorama of gorgeous scenes in Fairyland are pictured with brilliant photography remarkable for color treatment.

Prince Arthur enraptured with the lovely Princess Lena wins her as his betrothed. But such bliss is not long for him, for Zamaliel, monarch of the infernal regions, sets his covetous eye upon the fair princess. Then ensues a mighty battle between the Prince of Darkness and Fantasma, all powerful Queen of Good and Light, who watches ever over the lovers. The Princess, torn from her lover, is carried to the lower regions and then under the sea where weird and terrible trials beset her. The Prince is ever accompanied by the droll Pico in his wanderings in search for Lena and they undergo trials and wonderful experiences. The lovers, reunited, sail away at last on the Sea of Happiness—one of the most exquisite and original effects ever introduced into photography.

Fantasma, in thirty years, made ten millions gross. Book this greatest of features and cash in on its undying popularity and appeal.



TRADE MARK
Thomas A. Edison
Makers of the Edison Kinetoscope, Model "D"

THOMAS A. EDISON, Inc.
275 LAKESIDE AVENUE
ORANGE, N. J.



EXHIBITOR WANTS COMEDY WITH FEATURES

Special to MOTION PICTURE NEWS

Milwaukee, Wis., Dec. 8.

"Let the feature film concerns supply a reel of comedy with each of their feature productions and they will have a lot easier time getting bookings," is the suggestion made by A. Trinz, of the Rainbow theatre, Twenty-seventh street and Lisbon avenue.

"Many of the houses are in a position to play exclusive feature programs, but cannot afford to play features all the week around and pay for the regular service which is not used, with the exception of the comedy reel.

"If all four and five-reel features had a reel of comedy with them, it would be possible for the exhibitor to get away from his film exchange if he was in a position to play features right through the week. As it is, he has to pay as much for the occasional reel of comedy as he would for an entire program."

UNIVERSAL GETS LONERGAN

Lloyd F. Lonergan, author of "The Million Dollar Mystery" and of almost every big Thanhouser photoplay from the inception of that concern, has quit his position of producing manager of the Thanhouser establishment to become a writer of features for the Universal Eastern Stars. He is now spending time in conference with Julius Stern, manager of the Imp Studio, and with Ben Wilson, William Garwood and Miss Mary Fuller, for whom latter stars he will create his first Universal stories.

RAVER AND THOMAS LEAVE ALL STAR

Harry R. Raver has severed his connection with the All Star Feature Corporation, having disposed of his stock in that company.

Augustus Thomas, director general of the company, has also disposed of his holdings in All Star.

HE CAN'T AFFORD TO MISS A SINGLE ISSUE; CAN YOU?

Motion Picture News, New York City. Gentlemen: Will you kindly forward me copy of your issue of November 21, to complete my files. I do not wish to miss any of the valuable suggestions which your newsy paper contains.

The "News" certainly has a large field for usefulness, by not trying to cover too much ground perfunctorily. We need "quality" in the trade magazine as much as in the pictures. We must have the encyclopedia for occasional reference, but we must say we like to get our "Late news" in attractive dress. Your circulation must be growing fast.

Very truly yours,
GEO. N. SHERRY,
Southern States Theatre Company,
Knoxville, Tenn.

Orrin Johnson Joins Rolfe Photoplay Forces

Well-Known Stage Actor Will Appear in "Satan Sanderson," Forthcoming Release on the Alco Program—Has Played 200 Roles

ORRIN JOHNSON, who has just been engaged by the B. A. Rolfe Photo Plays, Inc., to play the lead in "Satan Sanderson," the forthcoming Alco release, began his career in the legitimate much earlier than the average actor and made his success in less time.

He was born in Louisville, Ky. He went on the stage with Effie Ellsler in 1887. In two months he was leading man. For three seasons he continued with Miss Ellsler as her chief male support.

In 1890 he was engaged by Charles Frohman for the juvenile part in "Men and Women." This was Charles Frohman's original stock company at Proctor's Twenty-third street theatre. The play ran for one year.

The next season, that of 1892-93, Mr. Johnson created the leading juvenile role in David Belasco's "The Girl I Left Behind Me," with practically the same company. This bill opened the Empire in 1893.

At the opening of the season 1900-1901 he joined Annie Russell in "The Royal Family." In 1901-1902 Mr. Johnson continued with Miss Russell, creating the Judge, in Clyde Fitch's "The Girl and the Judge." He also played the leading juvenile role in "Mice and Men" with Miss Russell.

The young actor was now prepared for stardom. In the latter part of 1904, at Daly's Theatre, he was starred with Margaret Illington in Onoto Watanna's "The Japanese Nightingale."

He was also starred in "Hearts Cour-

ageous." In the subsequent seasons engagements in the principal roles of "Ben Hur," "The Heart of Maryland" and "The Shepherd King" followed.

The entire season of 1907-08 he played the lead in George Bradhurst's "The Man of the Hour." The following season he



ORRIN JOHNSON

was featured with Marie Doro in "The Richest Girl."

Mr. Johnson's last work in New York was the creation of the lead in "The Marriage Game," and also that in "The Rule of Three." During his career to date he has played more than two hundred roles.

League Committee Meets in New York

Executive Body Created at Dayton Convention Last July Discuss Association Problems at Hotel McAlpin—Accepts Wiley Financial Report

THE executive committee of the Motion Picture Exhibitors' League of America met in conference at the Hotel McAlpin, New York City, December 8 and 9.

Marion S. Pearce, president of the League, presided ex-officio. Other members of the committee were: W. A. Cory, of San Francisco; Fulton Brylawski, of Washington, D. C.; Secretary Wilson, of Columbus, Ohio, and Peter Jeup, of Detroit, Mich. President Pearce held the proxy of T. P. Finnigan, of Dallas, Tex.

The committee accepted the financial report of George Wiley, managing director and chairman of the special convention committee appointed at Dayton, Ohio, last July. The McAlpin committee went over the report of Mr. Wiley Tuesday night and found that Mr. Wiley had prepared his report with unusual care, all items proving correct in every respect.

Another matter brought under consideration by the committee was the selection of a city for the next annual convention of the league. The choice lay between New York and San Francisco at a late hour of the conference on Tuesday afternoon. The final decision, it was thought,

would be made before the adjournment of the committee.

A subject occupying a great deal of the attention of the members of the executive committee was amalgamation. Various plans were under advisement for devising ways and means for promoting widespread interest in the league movement and increasing membership throughout the country. The details of the methods meeting the approval of the conferring members at the New York session will be announced later.

The executive board nominated two members to fill vacancies created by the members of the league at the Ohio convention. They were Judge A. P. Tugwell, of Los Angeles, and Fulton Brylawski.

ARE YOU USING IT? THESE MEN ARE. SEE PAGE 120

"You are using the brains God gave you."—CHARLES A. GATES, Lyric Theatre, Austin, Minn.

"It is fine business."—Edson Theatre, Fort Wayne, Ind.

The Balboa Amusement Producing Company
of Long Beach, California

Announces the engagement under a long time contract
of that eminent motion picture artist—

Henry Walthall

- The world's greatest and most popular cinematographic star—
- The marvelous actor who has dignified and enobled the moving picture drama—
- The man whose impersonation of difficult roles is a revelation of artistic achievement—
- The man who has won the enthusiastic applause of the multitudes—
- The man with a million loyal friends in the United States—
- The man with a name that guarantees box office success—

- The man whom the famous D. W. Griffith featured in "The Avenging Conscience"—
- The man whom the same wizard of direction selected for the lead in "Home, Sweet Home"—
- The man whom the infallible Griffith elected for the lead in "Judith of Bethulia"—
- The man who was depended upon by Mr. Griffith to make "The Clansman" last through twelve tremendous reels—
- The man who has scored more individual successes than any other living artist before the camera—the same

Henry Walthall

- Who supported Henry Miller during his triumphant runs in New York and his many tours of the principal cities of the United States—
- The man who made his debut in motion pictures with the Biograph Company of America under the direction of Mr. D. W. Griffith, and—

- Who later became leading man for the American Pathe-Freres Company.
- The man whom D. W. Griffith made the undisputed star of the Reliance and Majestic productions for the Mutual Film Corporation—

has signed with the

Balboa Amusement Producing Company

Henry Walthall, the inimitable and pre-eminent motion picture actor, will henceforth bear the Balboa colors. This is the first of a long list of important acquisitions that will be made by the Balboa Company. Watch for the other sensational announcements in the near future—announcements that will startle the entire motion picture fraternity.

The Balboa Amusement Producing Company

H. M. HORKHEIMER
Pres. and Gen. Manager

E. D. HORKHEIMER
Sec. and Treasurer

"Makers of Pictures Beautiful"

Studios and Executive Offices, LONG BEACH, CALIFORNIA

MAX FIGMAN IN "THE TRUTH WAGON," NEXT ALLIANCE RELEASE

Andrew J. Cobe, general manager of the Alliance Films Corp., was very much elated when he made the announcement that the next Masterpiece Film Co.'s release with Max Figman and Lolita Robertson in the leading parts would be "The Truth Wagon."



MAX FIGMAN

The picture was produced under the personal direction of Mr. Figman, who plays John Ross, the truth teller. The supporting company includes Al. W. Filson and



LOLITA ROBERTSON

H. A. Livingston. The scenario was adapted by Elliot J. Clawson from Hayden Talbot's play, while credit for the successful photographic results are due to Georges Rizard.

Object to Raising Building Funds on Sunday

Chattanooga Ministers Try to Oppose Plan, but Authorities Refuse to Revoke Licenses of Theatres Enlisted in Labor Temple Cause.

Special to MOTION PICTURE NEWS

Chattanooga, Tenn., Dec. 9.

THAT the Sunday opening of motion picture theatres at Chattanooga, Tenn., would draw capacity crowds and would result in many extra nickels going into the coffers of exhibitors is clearly shown from the fact that on a recent Sunday, when the theatres were allowed to open for the purpose of raising funds toward the erection of a labor temple, they were visited by more than ten thousand people.

Approximately 5,900 people visited the Theato, Colonial, Alhambra and Crescent theatres of Howell Graham and the Picto picture house, managed by M. Mugnier. These five theatres are located in the heart of the city on the principal downtown street within two blocks of one another.

The Alcazar Theatre, also situated in the same section, drew a crowd of 1,400. In

the neighborhood of 1,700 people attended the performances at the Royal in the southern part of the city, while the two East Ninth street houses estimated their attendance at 1,700.

Efforts were made by Chattanooga ministers to prevent the picture theatres opening on the Sunday in question and the board of city commissioners were criticized for allowing such a course of procedure. The chairman of a committee from the Chattanooga Baptist Pastors' Association appeared before the board and protested against allowing the theatres to open as had been planned.

He was told that the commissioners had granted permission to the exhibitors several weeks beforehand and as the labor union had gone to considerable expense preparing for the event the board's action could not be rescinded.

Los Angeles Membership Greatest in West

Eighty Per Cent. of Exhibitors In and Near City in Branch—Organizer Cory Expects All Shortly to Become Members of the Local

Special to MOTION PICTURE NEWS

Los Angeles, Dec. 7.

WITH fifty-three members in good standing, the Los Angeles League can now boast of the greatest organization of motion picture theatre owners of any city west of Chicago. The members represent fully eighty per cent. of the theatres of Los Angeles and vicinity.

The campaign for membership, started upon the arrival of W. A. Cory, state secretary and organizer, of San Francisco, was closed the early part of last week, when Mr. Cory left for his home, making the trip by auto and seeing all picture theatre managers and owners

along the inland route while on the way.

Local officers are not satisfied with eighty per cent. and expect to call on those not enlisted shortly, in an effort to raise the membership list to still nearer the 100 per cent. mark. A get-together meeting will be held for the purpose of outlining the work of the league.

Prior to the visit of Mr. Cory there were two other organizations besides the League here, the Theatrical Managers' Association and the M. P. Managers' Mutual Protective Association. The three organizations are now combined in one, the League.

OLGA PETROVA BEGINS "THE TIGRESS"

Work recently began at the Fort Lee studios of Popular Plays and Players, Inc., on the Alco release of December 21, Olga Petrova in "The Tigress."

"The Tigress" is the first picture to be done in the new studios. The equipment is the best that money can buy and the technical experts are among the highest salaried men in the profession.

The cast which supports Madame Petrova is a large one. Many of the scenes are spectacular in the extreme. There are many exteriors on a large scale.

BUCK HUNTING A FEATURE OF EXCELSIOR FILM

The opening scenes in "In the Shadows" are laid in the Adirondack woods, and the hero, Gordon De Maine, and his chum, William A. Williams, are shown stalking a deer. After much patient preparation and endless watching the camera was successful in catching a beautiful buck, grazing peacefully, unconscious of the impending danger. Suddenly he rears his head, and just as he scents his foe the danger overtakes him, and he sinks lifeless, a tribute to the prowess of the hunter.

Not only does this picture show excellent marksmanship, but the beautiful photography of this scene is certainly remarkable, more especially when one appreciates



GORDON DE MAINE IN "THE SHADOW"
(Excelsior-Alliance)

the hours of patient waiting that were necessary to secure what is after all only an incident in a five-reel story that is crammed with stirring incidents.

TENSE MOMENTS IN "THE SOWER REAPS," AMERICAN TWO REEL RELEASE ON MUTUAL PROGRAM



SCRANTON LYCEUM TURNS TO FILMS

Scranton's leading theatre turned to pictures not so very many days ago. Paramount pictures are being offered to Scrantonians. The theatre opened to a capacity audience. H. B. Warner in "The Lost Paradise" was the opening attraction.

Arrangements for the Paramount features in Scranton were made by Hiram B. Danziger, general manager for the Ries circuit of theatres in Pennsylvania, New York, Ohio and West Virginia. The same program will be installed in all of the Ries theatres, but will be broken only when a first class company in an assured success can be booked for local presentation.

Mr. Danziger has arranged a novel advertising scheme for the Lyceum. He gained considerable publicity and the good will of the people of Scranton when he announced that the Lyceum would contribute a percentage of the first month's receipts to swell the fund for the Red Cross of Scranton. The money was turned over to the Century Club, December 10, which will in turn hand it over to Robert Hull, of the Scranton Trust Company, treasurer of the local Red Cross. That will give the Red Cross fund a percentage of the receipts of twenty-eight days, with four performances a day.

Joseph Sexton has been engaged to operate the mammoth organ that is in the Lyceum.

COLLEGES BUY PRINTS OF FOOTBALL GAME

The athletic picture, the Yale-Harvard Game, which was produced by the Colonial Motion Picture Corporation, is meeting with unprecedented success as a topical feature. Aside from the better motion picture theatres throughout the East and Middle West, B. F. Keith has booked this as a special production on his regular vaudeville programs in all of the Eastern cities.

One print has been booked solid for thirty days to the central branch of the Young Men's Christian Association, which will show it in their associations and various branches throughout the East. Another new channel open to the picture are the Yale and Harvard clubs, which are buying copies outright, to be shown at the various banquets and gatherings of the respective clubs.

NEW COMPANY WILL BRING OUT UNUSUAL FILMS

A company backed by some of the biggest business men of New Haven, Conn., and headed by George R. Kelsey, secretary and treasurer, Algonquin Amusement Company, New Haven, has recently been organized for the purpose of putting on the market high class films for release through

ten offices, located throughout the country later.

According to the announcement of Robert M. Foot, who has become associated with the new concern as managing director, an entirely different line of motion pictures will be exploited.

The name of the company has not been decided upon, but it will be symbolic of the class of films produced in its studios. Plans are under way, which, when disclosed, will be a revelation to the film world, and will attract instant attention on account of the results expected from their practical scope.

Best Drama Unknown to Dramatic Critics

Not Many, But a Few, Allow Prejudice to Interfere With an Appreciation of Motion Pictures, Declares Carl H. Pierce, of Bosworth, Inc.

IN many places throughout the country the dramatic critic of the daily newspaper even in such cities as Boston, Buffalo, Pittsburgh, Columbus, have never heard of the better class of photoplays; they never attend the photoplay houses; they believe that nothing will ever supplant the "legitimate" drama, and they close their eyes to the tidal wave that is sweeping over the country known as the motion picture industry with its ever increasing quality-excellence in production.

Carl H. Pierce, special representative for Bosworth, Inc., who is making a tour of some of the principal exchanges of the country, substantiating this, says:

"I talked with one of the foremost dramatic critics of Boston last week. He said that he had never been to a photoplay in his life, had no idea what it is like, and had no interest to go. He may be said to be fairly typical of the dramatic editor of the average American newspaper.

"In Pittsburgh," continued Mr. Pierce, "I talked with three of the leading dramatic critics: Mr. Bahmer, of the *Post*; Mr. Bregg, of the *Gazette-Times*, and Mr. Rupp, of the *Pittsburgh Dispatch*. One of them said that he had never been to a motion picture show in his life; another said that he believed it would never supplant the legitimate drama, while the other said: 'Why should we interest ourselves in them?'"

"To those who are in the midst of photoplay production and exhibition such remarks may sound as absurd as to have

someone remark that he had heard of automobiles and aeroplanes, but why should he interest himself in them, the obvious answer being that one owes it to himself to be abreast of the times, especially if the community is looking to him for light upon the subject upon which he is supposed to be an authority.

"As is usually true of any industry—the general public learns about it first through its wideawake trade paper. One may trace the development of the motion picture industry to such active papers as *MOTION PICTURE NEWS*, because it is from such papers that the exhibitor gets his news, and hence—to a large extent—forms his impression of the films that are to be shown to his patrons.

"Would it not seem wise, however, for the dramatic critics—instead of being 'trailers'—to be 'leaders'? Does it seem reason in this day and age for men, supposed to be posted on things dramatic, to ignore an industry which bids fair to support more dramatists and more actors than have ever been supported before?"

"Does it seem reasonable that this greatest opportunity in our civilization for enlightening and uplifting people should be passed by unnoticed by the men who should notice it? No, it does not. And it will probably remain for such papers as *MOTION PICTURE NEWS* to take up the burden of this educational program, thereby proving to their brethren of the daily press that in many respects the trade paper man is the more awake to news conditions."

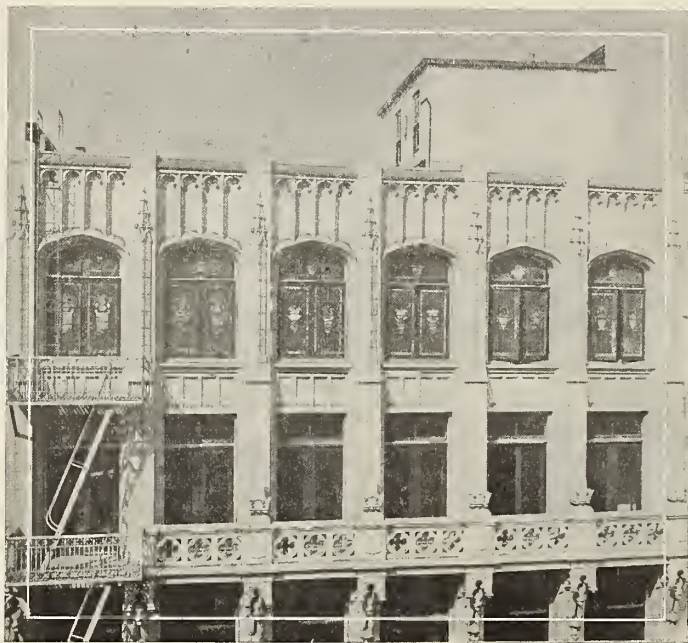

HOME OF THE INDUSTRIES EDUCATIONAL COMPANY



OFFICE OF W. M. FREESE, PRESIDENT

FREESE, ORGANIZER OF INDUSTRIES EDUCATIONAL

AFTER a study of the production of motion pictures by American and foreign manufacturers, W. M. Freese, has organized the Industries Educational Film Company, and will begin production at the new studio on the ninth and tenth floors and roof of the Knickerbocker Building, Los Angeles.

This company will manufacture motion pictures of all kinds, including educational, comedies, one and two-reel dramas, as well as multiple reel features. In addition to this the company will conduct a commercial studio, where sets may be leased for the day, week, month or year.

Every feature of the manufacturing business has been looked after by Mr. Freese, and he has so arranged and constructed this studio that the cost of production can be decreased from fifty to seventy-five per cent. At the

same time the settings provided will tend to increase the quality of the pictures by reason of their being far superior to artificial sets.

For the past three months scores of workmen have been engaged in transforming the two upper floors and roof of the Knickerbocker Building, 643-45 South Olive street, into a studio, with permanent sets that give practically every desired effect without a change of anything except such props as chairs and tables.

Mr. Freese long ago came to the conclusion that it would be far less *expensive* to move the *players* and *camera* than the sets, and this studio is built upon this advanced plan. Without the change of decoration or moving any regular piece of furniture, it is possible to make interiors of the kitchen, dining room, parlor, library,



TWO OF THE BEAUTIFUL PARLOR, CONSERVATORY OR CHAPEL SETS OF THE STUDIO



PRESIDENT FREESE AT ENTRANCE TO ENGLISH INN SET



VIEW OF MAIN AUDITORIUM IN THE STUDIO

FILM COMPANY, LAUNCHES NEW PRODUCING PLAN

chapel, conservatory, offices, theater stage, street scenes, English Inn, and scores of others.

One of the unique effects is that of the windows. There are twenty-eight in all, which provide three times that many effects. This is accomplished by each one being fitted with a prism glass window, one of leaded glass, and a third of the old English style. Besides these, each opening is fitted with reflectors and light-proof shutter.

The lighting is accomplished by means of skylights of prism glass and open traps, fitted with mirrors and mammoth reflectors. Every part of the studio is wired for

artificial lighting and the latest improved electric lighting system has been installed.

The laboratory is located at the rear of the ninth floor. Here the drum system is in use, with ruby light windows, automatic door locking devices, and other new features.

There are offices for director, large dressing rooms for the stars, ten for stock people and 'extras' dressing rooms to accommodate two hundred, fitted with shower baths, hot and cold water, overhead reflecting mirrors, and every convenience to be found in the finest theater dressing rooms.



EXTRA DRESSING ROOM



STAR'S DRESSING ROOM



CORRIDOR OF WOMEN'S DRESSING ROOMS

"THE MAN BEHIND THE DOOR"

(Broadway Star Features-Vitagraph—Four Reels)

REVIEWED BY PETER MILNE

THIS is a comedy that resembles the stage farce, the kind that still entertains and draws full houses. It is of the variety that has been thought unsuitable for the screen, simply because the large number of characters that appear and the complicated story in hand has presented too great difficulties for the director to overcome.

These same evils are not always overcome by stage directors, but here the story is perfectly plain, only slightly lengthy. It could and in all probability will be cut, and thus be presented in a more compact form, and will therefore be a better and more laughable comedy.

Wally Van has directed the picture, which was picturized by Marguerite Bersch, from the book by Archibald Clavering Gunter. Mr. Van also plays the name part in his usually funny style. Nitra Frazer is the professor's daughter, with whom De Lacey is in love and who he finally marries after they have quarreled and gone through innumerable funny and startling experiences.

Others in the cast who contribute to the general fun in the picture are Harry Morey, Cissy Fitzgerald, Albert Roccardi, Charles Wellesley, William Shea and Louise Beaudet. All have been assigned many humorous opportunities, and all make good use of them.

Like the stage farce again, the picture's moral is "Have a good time while you're young," and for that matter, while you're old, too. Anyone who sees "The Man Behind the Door" will forget that he ever had a care.

MINA FILM FEATURES A COUNT

COUNT VERACE, a dapper little fellow, makes a great hit with the pretty girls at a summer hotel, especially with Dora. George, her sweetheart, is jealous and forbids her to see the count. But she flirts with the count by dropping her parasol for him to pick up. George, seeing them together, is more jealous than ever and hires a gang of thugs to revenge him on the count.

The gangsters drop the count from the roof of a tall building but he jumps up uninjured. They tie the count to a railroad track but he loosens the ropes and jumps onto the cowcatcher of the onrushing engine. The count is recaptured by the thugs after a chase through the woods and bound to the rear seat of an automobile. The automobile is sent over a precipice with a thrilling crash, but the count crawls out from under the wreckage uninjured, and goes back to the hotel. He is making love to Dora when George comes in, sees him and faints away, crushed by the count's triumph.

VALENCIA THEATRE, FRISCO, REOPENED

Special to MOTION PICTURE NEWS

San Francisco, Dec. 7.

THE Valencia theatre, located on Valencia street, near Fourteenth, San Francisco, has been reopened as a picture house and every effort will be made to make the venture a success. Feature photoplays are to be shown at five and ten cents, with children under twelve years of age admitted free, when accompanied by parents. A full string orchestra has been installed and on Sundays a vaudeville performance is given.

The house opened under the new policy on November 20. This theatre was one of the first permanent houses to be erected following the great fire of 1906 and for a time was the home of a large stock company.

Later it was devoted to grand opera and has been opened as a moving picture house several times with indifferent success.

WANTED RESERVED AT PRICE OF ORDINARY SEAT

Special to MOTION PICTURE NEWS

Omaha, Neb., Dec. 8.

CAN a motion picture theatre, giving several shows a day, retain its reserved seats at a higher cost? The question is before the district court. A man started suit for \$2,995 damages from Manager Frank Harris and the Empress theatre because he could not occupy a reserved seat for 10 cents, the price of general admission. The reserved seats sell for 20 cents. It is a sort of trial case. It started before a jury, but the parties took it from the jury and presented their arguments before a judge. The decision has not yet been made.

"SHOULD A WOMAN DIVORCE?"

(Ivan Productions—Five Reels)

REVIEWED BY WILLIAM RESSMAN ANDREWS

THE increase of divorce in the United States in the last few years has reached such an alarming extent that it has not only called forth the anathemas of the pulpit, but has become the subject of innumerable novels and dramas.

From time to time it has also been made the theme of film plays. The latest photo drama to treat this incubus of modern American life is "Should a Woman Divorce?"

The Ivan Film Productions Company has handled in a masterly manner in this play some of the chief causes of divorce.

The play does not attempt to present any solution of the problem and is free from didactic treatment. It wisely gives—in excellent pictorial form—some of the evils responsible for the upheaval of domestic relations, and rests its case, as it were, before the jury—the public. The facts are there—take them or leave them, according to your temperament. If you are severe in your judgment of the actions of your fellow creatures the conclusions you will draw will have a wide divergence from your more lenient neighbors. A great deal is evident in this strong play on a vital national subject which will afford food for reflection for both types of thinkers.

The producers have by no means lost sight of the demand of the law of contrast in dramatic construction. The tense moments are relieved by judiciously placed scenes of lighter touch.

In this respect the producer, Ivan Abramson, deserves great credit. His episodes show a mastery of stage technique.

He has also demonstrated rare judgment in his selection of a cast capable of interpreting difficult roles.

NEW DISSOLVE FEATURE IN "MUTUAL GIRL"

IN the coming numbers of the "Mutual Girl" release, made by the Reliance Motion Picture Company, a novel plan has been adopted wherein certain prominent people tell a story to Margaret, "Our Mutual Girl."

In the coming three or four releases, some of America's foremost illustrators and writers have agreed to furnish the Reliance with material for these releases, among them William Faversham, George Barr McCutcheon and May Wilson Preston.

Instead of having a story or scenario, the Reliance Company have been making arrangements with America's foremost authors, illustrators, society people and financiers to tell Margaret a story which they consider one of the most interesting episodes of their lives.

The reel will open with Margaret meeting the individual in question, and will then fade into the story told, which will be enacted by a large stock company, especially engaged to fill the bill.

The first of this series is when Margaret meets William Faversham, one of America's foremost actors; and he tells her the story of "The Hawk," which is the name of the play he is now appearing in. George Barr McCutcheon has also met Miss Phillips, and has told her of a new plot which he intends working into a story.

CLASSIFIED

Man thoroughly familiar with every branch of film business, now employed in an executive capacity, desires to make a change. My record is my best reference. If you have need for a man who can do things, write William, care of "News."

THE NEWS FOR INFORMATION

Motion Picture News,
New York City.

Gentlemen: I rely on the
"Motion Picture News" for
information each week.

Very truly yours,
W. F. HARRIS,
Richmond, Va.
Superior Theatre.

RELEASE NOV. 23rd

DIGBY BELL

in

THE EDUCATION
OF MR. PIPP
(5 Parts)

—DECEMBER 28th—

JANE COWL

in

THE GARDEN OF
LIES

All Star Feature Corp.

220 West 42d Street New York

“Rescue of the Stefansson Arctic Expedition”

Russian Official and Native Life in Siberia

ANIMALS OF THE FROZEN NORTH THREE FEATURE PICTURES IN ONE

The Best of 50,000 Feet of Film Condensed into the Greatest
Eight Reel Feature Ever Released



“WATCHFUL WAITING.” CHIEF ENGINEER MONROE OF THE “KAR-LUK” TAKING HIS TURN ON THE LOOKOUT

This Picture has had wonderful Newspaper and Magazine Publicity

The World Is Waiting To See It

State Rights Now Selling

Film buyers communicate at once regarding your territory



LAST PICTURE OF STEFANSSON (LEFT) AND CHUCKCHEE INDIAN SQUAW (EAST CAPE, SIBERIA), PREPARING DINNER (RIGHT)

Sunset Motion Picture Company

401, 110 W. 40th St., New York Hearst Building, San Francisco, Cal.



STEFANSSON STARTING ON HIS LAST DASH NORTH OVER THE ICE IN HIS EFFORT TO REACH BANKSLAND. (SINCE STARTING, THE PARTY HAS NOT BEEN HEARD FROM).

Many Film Companies Must Find New Homes

The recent ruling of the New York Fire Department has forced some of the leading moving picture concerns to seek other quarters. So strict are the new orders that only a very few buildings in New York can house film companies. One of them is the

Masonic Building

Sixth Ave. and Twenty-third St.

This splendid 19-story structure is absolutely fireproof. It has automatic sprinklers, cement floors, unobstructed light on four sides, steam heat, seven passenger and five freight elevators (the latter with independent entrances) and 11-foot ceilings. Many film companies are already in the building. There remain

Three Floors To-Let

The fifteenth, sixteenth and seventeenth, each containing 14,000 square feet, at \$8,000 per floor per annum, making the rent but 57.1 cents per square foot. Will divide, if necessary.

Before you sign lease, be sure you are "Within the Law"

For particulars address:

Charles F. Noyes Company

92 William St. Phone—John 2000

WHAT DO YOU NEED AS AN EXHIBITOR ?

- Accurate Release Pages?
- Exhaustive Reviews?
- Money-Making "Live-Wire" Hints?
- Helps on Projection?
- Idea-Inspiring Features?
- Eye-Opening Construction Articles?
- Musical Advice by Practical Musicians?
- Exhibitors' League News?
- Last Minute Information on Everything?

ALL THIS AND MORE

MOTION PICTURE NEWS

IS OFFERING YOU

IN EVERY ISSUE — EVERY WEEK

Five pages of the most complete release charts to be had—

Ten to fifteen pages of film reviews—

Fifteen pages devoted solely to equipment and accessories—

The news of the trade classified and arranged to meet your busiest moments—

YOUR EVERY NEED ANTICIPATED AND MET BY MEN WHOSE BUSINESS IT IS TO KNOW THEM

Can you afford to be without such a Trade Journal?

PREPARES FOR "WARRENS OF VIRGINIA" PRODUCTION

THE Jesse L. Lasky Feature Play Company's studio in Hollywood, Calif., has suddenly assumed an extraordinarily martial aspect owing to the special preparations which are being made for the production there of Blanche Sweet's first Lasky-Belasco release—"The Warrens of Virginia."

It will be remembered that this play, which was written by William C. De Mille, and produced under the management of David Belasco, is a story of the Civil War. As produced on the stage the war-like effects were necessarily restricted to a degree, but as seen on the screen this is positively to be the most elaborately realistic romance of war-times ever presented.

Guns, sabres, uniforms, all the equipment for infantry, cavalry and artillery, are being acquired almost by the carload. Field artillery, siege guns, mortars, rapid fire guns and all other weapons which were extant at the time of the Civil War are literally heaped all over the premises. Extra players are being engaged by the hundred, and the photodrama is surely going to reproduce the boys of '63 on both sides of the contest not only individually, but in masses and hosts of marching men.

General Cecil B. De Mille, who is only ordinarily director general, but now seems to have acquired a military meaning for his title is in command of the allied forces to pose on both sides of the battle line. He says it is a good thing that the encampment is not too near the border as the Lasky organization might fall under suspicion of violating neutrality.

BUSINESS REVIVAL THROUGHOUT TEXAS

TEXAS exhibitors and exchangemen are experiencing a business resurrection.

The general improvement of financial conditions, starting with the first movements of the huge cotton crop, has reopened a great number of theatres, and increased exchange receipts accordingly.

Statements from the south tell of an almost complete suspension of business among exhibitors in the smaller towns in the early fall. This was due to the scarcity of funds among planters, who had taxed their finances to the utmost to move the great harvest of cotton. This, in turn, reacted upon the public by creating a sort of enforced wave of strict economy.

August and September, and in some sections, October witnessed closed doors in many of the smaller theatres. Patronage fell at an alarming rate during the summer months. Gross proceeds dwindled to less than the cost of service. Exhibitors demanded cheaper rentals.

With the reawakening of business activity a decided change in the demands of theatre patrons has been experienced. Features are in greater demand than ever, it is said. Sensational pictures have a certain demand, but it has lessened considerably in preference to interest in productions of superior quality.

From certain sections come reports of instances where exhibitors are obtaining admission prices varying from ten cents to twenty cents and a quarter for features, with a dime for regular program entertainment.

ESSANAY PLAYERS GO TO NEW YORK FOR SCENES IN "GRAUSTARK"

MISS BEVERLY BAYNE, Helen Dunbar and Thomas Commerford left for New York, Saturday, December 5, where they joined Francis X. Bushman, who went to New York earlier in the week to take scenes in Essanay's "Graustark," by George Barr McCutcheon.

Francis X. Bushman will play the leading role, that of Grenfall Lorry, the young American who falls in love with a princess of "Graustark." Miss Bayne will be the Princess Yvonne, and Thomas Commerford and Miss Dunbar will take the parts of her uncle and aunt who are traveling through America with her.

The scene in which Lorry rushes to New York to get a last glimpse of his princess, whose rank he is entirely ignorant of, will be taken on the wharfs of the Atlantic liners to make it absolutely true to the story.

The players will then go to Washington, where all the scenes that took place there in the story will be reproduced with exactness to the text. Other scenes will be taken on the very line Lorry met the princess traveling from Denver to New York via Washington.

1915 SHOULD BE A YEAR OF HIGHER PRICES, SAYS PRESIDENT LAEMMLE



Carl Laemmle, president of the Universal Film Manufacturing Company, sent this greeting to the trade through MOTION PICTURE NEWS:

"My New Year's greeting to you is the hope that you may have the best year's business in your life. If you work with me you will have, too. I believe we are going to have much better times from now on. We have begun to put the picture business on a higher paying

scale. The Universal has done wonders in raising the quality of the program.

"My best wish for you is that you may receive the full benefit of that advance in quality by raising your own box office prices and your consequent standing in your community.

"An opportunity is open to you with the beginning of the new year. By all means grasp it. Your patrons know that you have a better show than you did on January 1, 1914. If they didn't they wouldn't be your patrons. They would be going to some other theatre. They know, too, that they do not pay any more for this better show than they did on January 1, 1914.

"Your patrons are not more unreasonable than any other people, and they will see that you are right if you present the matter to them in the proper light. Don't be afraid to do it. And 1915 will be the best year in your life."

CAPITAL EXHIBITORS SUBMIT GRACEFULLY TO WAR TAX

Special to MOTION PICTURE NEWS

Washington, D. C., Dec. 8.

THE day for the initial paying of the war tax on the motion picture theatres has come and gone and, so far as ascertained, there is no grumbling here. Generally speaking, this amuse-ment is in quite a prosperous condition, with even a more favorable aspect.

Of course, one must realize that the exhibitor is in the time of the passing of the small, nickel theatre, and the one that is unattractive and uncommodious. There are scattered theatres that are not doing a prosperous business, but bad management is usually responsible for this. The up-to-date manager reports favorable conditions financially.

President Herbst, of the local Motion Picture Exhibitors' League, offered assistance to exhibitors prior to the day of paying the war tax by reminding them of this assessment and thus saved some of the exhibitors the additional fifty per centage that failure would have caused.

JACK ROSE WILL MAKE HUMAN INTEREST PICTURES

JACK ROSE is enthusiastic over the prospects of the Humanology Film Producing Company, of which he is president. Already he has enrolled Ella Wheeler Wilcox to contribute toward the output of his firm, which, he avers, will be distinctive and is to be distributed through the forty-two exchanges of the United Film Service (Warner's Features, Inc.).

Rose feels elated, too, that by his entrance into the motion picture business he establishes himself in a business that will vouchsafe his energies a wide latitude for legitimate activity. Since the crisis that came into his life with the hearing of the sensational Rosenthal case, he has eschewed former haunts and habits and has devoted his efforts toward aiding sociologists in solving the problems connected with that condition of life which is vaguely known as "the underworld."

"There, but for MOTION PICTURE NEWS, is where I would have been,"

said a western exhibitor not long ago, as he stopped to read the sheriff's notice on a competitor's theatre.

IS THE FIRE DEPARTMENT AFTER YOU
DO YOU HAVE TO MOVE



Film Storage Vaults
Convenient—Accessible—Safe
Will Solve Your Troubles

Fireproof Construction and Full Insurance

Deliveries on Five Minutes' Notice



LLOYDS FILM STORAGE, 220 West 42d Street
Bryant 5600

The Most Sensational Hit of the Year

“IRELAND A NATION”

Written and Produced by

WALTER MACNAMARA



A Merry Christmas to All

MACNAMARA FEATURE FILM CO., Inc., 126 West 46th Street
Telephone 3023 3024 Bryant
NEW YORK

THE POLICE AND MR. BROWN

ONE of Nat. I. Brown's latest experiences is the trouble he encountered the other night with the police. Mr. Brown, one of the Alco Film Corporation's live wires, received telegraphic orders late in the evening, demanding at once 30,000 heralds for "Little Lord Fauntleroy" and "The Education of Mr. Pipp." There were few employees in the Alco building. With the aid of these, Mr. Brown made up three bundles of 10,000 heralds each and chartered a taxicab. He and his assistants hurled the bundles to the waiting taxi.

Knowing that a train would leave the Grand Central shortly which would enable good connections to be made all the way through to the coast, Mr. Brown was anxious to put the heralds aboard this train. As he was putting the last of the bundles in the taxicab, three uniformed policemen stepped up, and wanted to know what he was doing "taking stuff" out of the building at that time of night.

Mr. Brown tried to explain. The police assured him they knew that he and a "gang" were looting the building. Only upon the production of business cards, and the assistance of other persons in the building, did they finally permit Mr. Brown to hurry away on his errand. The heralds barely got the train.

WILL FILM KENTUCKY INDUSTRIES FOR FAIR

Special to MOTION PICTURE NEWS

Cincinnati, Dec. 9.

THE International Film Products Company, of Dixmyth and Clifton avenue, this city, has bought the rights for making motion pictures of Kentucky industries, for exhibition at the Panama-Pacific Exposition next year.

The deal will make it possible to pay for the erection of the Kentucky State Building at the exposition, as the sum of \$75,000 is mentioned as the settlement for the rights.

The negotiations were closed by Frank E. Aid, general manager of the local film concern, and Harry P. Meyers, treasurer of the Kentucky Exposition Committee.

QUADRUPLE EXPOSURE WORK IN ESSANAY FILM

A TRIPLE masked exposure marks an unusual feature in the new Essanay prize mystery play, "The Battle of Love," released December 19. In this scene Francis X. Bushman is discovered in his office at the telephone on one side, and Ruth Stonehouse, his sweetheart, at the phone on the other side. In the center is a picture of a street with the telephone wires. From these wires flash out the message on the screen, letter by letter. This requires a fourth exposure to work the letters into the central picture, making it practically a quadruple exposure to finish the picture.

DEMAND
GRANDIN FILMS
Featuring Miss Ethel Grandin
From your nearest United Film Service Office (Warner's Features)



*Send for
Special
Advertising
Matter
Now*

ETHEL GRANDIN	framed lobby display: A beautiful set of six real (5x7 & 8x10) photographs with mission finish frame, glass, back etc.	\$3.00
ETHEL GRANDIN	framed poster. Beautifully finished, seven colors. Varnished and backed. One sheet size.	1.50
ETHEL GRANDIN	one sheet litho posters (three styles)	each .10
ETHEL GRANDIN	hand colored announcement slides	each .15
ETHEL GRANDIN	Electros (1 column for newspapers)	each .25
ETHEL GRANDIN	Special process colored post cards	per thousand 3.75
ETHEL GRANDIN	photographs (11x14 inches for lobby)	each .25
ETHEL GRANDIN	Photo buttons: For souvenirs	per thousand 3.50
ETHEL GRANDIN	Photo Mirrors	per hundred 2.20
ETHEL GRANDIN	Posterette Stamps	per thousand 1.50
ETHEL GRANDIN	Pillow tops (Heavy Gold Satine 18x18)	each .50

Scenario Writers—We can use Two reel comedy dramas suitable for featuring, Miss Grandin.

SMALLWOOD FILM CORPORATION
175 FIFTH AVENUE, NEW YORK, NEW YORK.

Ray C. Smallwood. Arthur N. Smallwood.
V. Pres. & Secy. Pres & General Mgr

**AN ENGINEER COULD RUN SAFELY
WITHOUT ANY SIGNALS—**

sooner than an exhibitor could safely get along without full and complete release date charts.

That's why the exhibitors who take MOTION PICTURE NEWS wouldn't give it up.

BOOK
WHEN
FATE
LEADS
TRUMP
(Four Parts)

EXCELSIOR

FEATURE FILM COMPANY, INC.

110 WEST 40th STREET, NEW YORK CITY

BOOK
THE PATH
FORBIDDEN
ALLIANCE
PROGRAM

B. A. ROLFE

PRESENTS

MABEL TALIAFERRO

in

"The Three of Us"

By

Rachel Cruthers

Released Dec. 14th

Under the direction of John W. Noble.

.. ALCO PROGRAM ..

Produced by the ROLFE PHOTO PLAYS, Inc.

1483 BROADWAY, NEW YORK

Next Release

ORRIN JOHNSON

(His first appearance on the Screen)

in

"Satan Sanderson"

By

Hallie Ermine Rives



NAME

THEATRE

ADDRESS

MOTION PICTURE
NEWS

220 W. 42nd STREET

Enclosed find \$2
for which en-
ter my Sub-
scription
for 1
year.**FREE****PORTRAITS OF STARS
IN SIX COLORS**

The beautiful portrait of Blanche Sweet in this issue of MOTION PICTURE NEWS will be followed by those of many others during 1915. The second of the series will appear in an early issue in January.

Each one of the series will be an equally beautiful portrait of a well known picture star; each in six colors, same artistic offset process, same size, same quality throughout. All will be loose inserts, ready for framing for your lobby.

This series, nothing equal to which has ever been obtainable before, is FREE only to yearly subscribers to MOTION PICTURE NEWS.

New Subscribers, those who subscribe *now*, will secure the entire series free. Old subscribers must renew promptly in order not to miss any.

Do you subscribe? If not tear off the above coupon.

Mail it to us with \$2—check, money order, or bill—NOW while the page is before you.

MOTION PICTURE NEWS
220 West 42nd Street New York

THE LAST EGYPTIAN



IN FIVE PARTS

Released Dec. 7th on the

ALLIANCE PROGRAMME

A weird and spectacular modern drama staged in Egypt and London on a colossal scale, presenting a story abounding in thrilling scenes and powerful dramatic situations.

A sensational photodrama combining the mysterious atmosphere of the Orient with the "punch" of American production and American actors.



Terrific Battle to Death in the Secret Treasure Chamber Has Been Pronounced

The Greatest and Most Realistic Fight Ever Seen in a Motion Picture

Gorgeous Costumes and Magnificent Settings, combined with the famous Oz Cast of beautiful women make "The Last Egyptian" a film to be long remembered

FARRELL MacDONALD
"The Last Egyptian"
with VIVIAN REED and the usual strong Oz cast.

THE OZ FILM MFG. CO.

SANTA MONICA BOULEVARD—GOWER to LODI STS.
LOS ANGELES - - CALIFORNIA



Banishing The Five-Cent Jinx

By E. Christy Erk

When Harry Nichols Took the Garden Theatre in Hand, It Was Languishing Under the Tyranny of the Nickle—Nichols Found it a Nিকেlette and Raised it to a Theatre, and This Is How it was Done.

INTRODUCING Harry Nichols, manager of the Garden theatre, Waterbury, Conn., and at the same time settling once and for all—at least so far as Waterbury is concerned—how far the manager of a theatre dedicated to the silent drama will go when he has the backing of the rank and file of the city's motion picture lovers.

When Mr. Nichols took hold of the Garden last January it was in the "down and out" class. The theatre wasn't "pulling," even enough to keep its head above water.

But when he took charge it was the beginning of a new regime, a regime destined to be a lasting one. Indeed, the story of Mr. Nichols's success reads like a tale from the Arabian Nights, something little less than meteoric.

"How are you doing it?" he was asked, and then the facts came out—uncensored.

THE early chapters are familiar to most exhibitors. It was a case of working up, getting the confidence of the people and then keeping it. Mr. Nichols secured a program of pictures which he thought the public would like.

And they did. That was the start, the passing of the first milestone on the road that leads to success. Soon he decided to give away gold pieces on "dull" afternoons.

In this way he patched up the weak spots. Next he admitted children under twelve years of age free to matinee performances when accompanied by adults. Score one for Mr. Nichols.

Keeping his eyes and ears open he soon discovered that his patrons were vitally interested in the program for the different days of the week.

"Why not have a 'Garden Weekly'?" "Good idea, I will." Patrons were surprised on coming into the theatre one day to have flashed on the screen the announcement that if they left their name and address at the box office, the Garden Weekly would be mailed to them every week.

AND so matters went on until after a few weeks when Mr. Nichols decided to enter the "Steve Brody" class and take a regular chance. Here's what he did. Had his house—quite a pretentious one—rehung with tapestries, a white background set in with roses.

On the stage he had giant rose bushes and vines set up with electric American beauty roses. The same went for all over the house, even out in the lobby.

In other words he transferred his theatre into a garden of American beauty roses. All the vines, bushes and roses are fireproof and have been tested by the fire commissioner and acclaimed so.

He didn't just like his stage and began burning the midnight oil and tallow in an effort to ring in a "scoop." What was the result. To-day the Garden stage is the pride of the city.

MR. NICHOLS terms it a "futurist stage." On the right side is an Oriental living room and on the left a den. When the new lighting effect is switched on the scene presented beggars description. All the new stage settings are hand painted, there being not a bit of stencil work.

Did his patrons appreciate what he was doing for them? They did. And how did they show their appreciation? Listen! They did it in the right way—by simply jamming the house every afternoon and evening.

At 8 p. m. it's an impossibility to gain access to the Garden, which seats 1,000. Playing to capacity? Well, it looks that way, doesn't it?

"I am making more money right now than I ever made before," is one of Mr. Nichols statements made only last week.

IN back of this mirroroid, Mr. Nichols has a transparent screen through which the audience views tableaux. A ship-wreck scene has been used the past week or so, and when the moving picture curtain ascends and the variegated lights are lit it means vociferous applause from the audience.

Mr. Nichols began by using the Famous Players program and booking his Sunday features from the open market. The daily program consisted of five feature reels with two or three single ones as "fillers."

The Garden showed the Famous Players program until October 3, when the Paramount program was put in operation, with the Lasky features, such as Dustin Farnum in "The Virginian," H. B. Warner in "Lost Paradise," etc.

Pretty good for a city of 85,000 inhabitants. But Mr. Nichols is a big

manager and to meet the added expense he is going to pull his house out of the "nickelette class."

THE Garden is now under way as a ten and fifteen cent house. "I want to give the public something better than they are getting," says Mr. Nichols, "and in order to do this I secured the Paramount program.

While it's a big expense by raising my prices I know I can meet it.

"Of course, it's going to drive away my five cent patrons, but it means that a better class is coming in. My theatre is altogether too nice to be classed with the five cent houses. I am going to put on a new three piece orchestra consisting of violin, piano and cello.

"Right now I am sending out 5,000 pamphlets to my clientele telling of the new change in program and increase in prices.

"I plan to run only one show an evening when I start the Paramount, although I may be obliged to run two of the reels a second time for the tardy ones.

I PROPOSE to increase my force of girl ushers by two more, making four in all. Pretty good plan, don't you think so?"

Mr. Nichols has got the public writing to the newspapers about his house. The following from a recent issue of the Waterbury Sunday Republican is self explanatory:

Sir:—The manager of the Garden theatre is to be congratulated. I thought he would be the first to show the much desired Mary Pickford productions as well as the other first-class pictures he is showing lately. This is not a new scheme for advertising, but the well deserved praise of

A SATISFIED GARDENER.

This manager put personal ambition to the rear and his house to the front, and then reaped the harvest when the crop ripened.

Director Handled Recruits Like a General

T. Hayes Hunter of the Colonial Had His Work Cut Out for Him Commanding Seven Hundred "Soldiers" in the Parker Picture

GREAT care was taken and no end of trouble was caused Director T. Hayes Hunter, of the Colonial Motion Picture Company, in the production of a few incidental battle scenes in its feature, "The Seats of the Mighty," founded on Sir Gilbert Parker's novel of that name.

That the scenes were simply incidental, and that few of the important characters appeared in them, only goes to show what great trouble producers

will go to in order to make their pictures complete and realistic.

Mr. Hamilton has had many years of experience as director, both in stage and in motion picture productions, and if the task had been in the hands of a beginner, there would have been mutiny at Edgewater, N. J., where the scenes were taken, before the day's end.

As it was, Mr. Hamilton handled the six or seven hundred raw recruits like a general.



QUALITY FIRST

“NOTHING TOO GOOD FOR THE EXHIBITORS!”

THIS slogan—the basic principle of the newest, keenest, livest organization of exchangemen in the United States—is guaranteed by the entire capital of the

**STANDARD
POLYSCOPE CORPORATION**

(Authorized Capital \$1,000,000)

and by the expenditure of half a million dollars in newspaper publicity—in the newspapers in *your own home town*, Mr. Exhibitor, boosting *your* theatre and the fact that *you* show the

STANDARD PROGRAM

a wholesome, clean, entertaining, instructive program of superlative quality released by

STANDARD PROGRAM ASSOCIATION

BEGINNING JANUARY 18th, 1915

AND BOOSTED BY 600 LIVE NEWSPAPERS

STANDARD POLYSCOPE CORPORATION

WM. P. COOPER, President

115 BROADWAY

H. C. HOAGLAND, Gen'l M'g'r.

NEW YORK CITY

**FOR INFORMATION REGARDING THIS NEW SERVICE
WRITE THE STANDARD PROGRAM ASSOCIATION**

JOSEPH HOPP, Pres.
164 W. Washington St.
Chicago, Ill.

NELSON F. EVANS, Vice-Pres.
Commercial Bldg.
Cleveland, Ohio.

D. S. MARKOWITZ, Vice-Pres.
California Film Ex.
Los Angeles, Cal.

SAM'L WERNER, Treas.
14 N. Ninth St., St. Louis, Mo.

E. T. PETER, Secy.
Dallas, Texas.

What Do You Need?

LISTING IN THE BUYERS' GUIDE, FOR NAME AND ADDRESS, INCLUDING ONE YEAR'S SUBSCRIPTION TO MOTION PICTURE NEWS—\$8.00 A YEAR, CASH IN ADVANCE. FREE TO ADVERTISERS USING \$100.00 OR MORE WORTH OF DISPLAY SPACE DURING THE YEAR. ADDRESS ADVERTISING DEPARTMENT

ADVERTISING NOVELTIES

Philip Hano, 806-810 Greenwich St., New York.

ANNOUNCEMENT SLIDES

Niagara Slide Co., Lockport, N. Y.

ASBESTOS BOOTHS

Sharlow Bros., 442 W. 42nd St., New York.

CLEANING AND RENOVATING FILM

Film Redeveloping Co. of America, 145 W. 45th St., New York.

Multicolor Film Improving Co., Inc., 15 E. 26th St., New York.

COSTUMERS

Miller-Costumier, 236 South 11th St., Philadelphia, Pa.

DEVELOPING TANKS

A. J. Corcoran, Inc., 9½ John St., New York.

ELECTRIC LIGHTING SETS

The Chas. A. Strelinger Co., Box P-2, Detroit, Mich.

FILMS

(Manufacturers, Dealers and Renters)

American Film Mfg. Co., Chicago, Ill.

Thomas A. Edison, Inc., 275 Lakeside Ave., Orange, N. J.

Essanay Film Mfg. Co., First National Bank Bldg., Chicago, Ill.

General Film Co., 200 Fifth Ave., New York.

George Kleine, 166 N. State St., Chicago, Ill.

Lubin Mfg. Co., Philadelphia, Pa.

G. Melies, 204 E. 38th St., New York.

Mutual Film Corp., 71 W. 23rd St., New York.

New York Motion Picture Corp., Longacre Bldg., New York.

Pathé Freres, 1 Congress St., Jersey City, N. J.

Renfax Film Co., Inc., 110 W. 40th St., N. Y.

Selig Polyscope Co., Chicago, Ill.

The Balboa Amusement Producing Co., Long Beach, Cal.

Thanouser Film Corp., New Rochelle, N. Y.

Universal Film Mfg. Co., 1600 Broadway, N. Y.

FILM ACCESSORIES

Berlin Aniline Works, 213 Water St., New York.

FILM TITLES, PRINTING, DEVELOPING, ETC.

Commercial Motion Pictures Co., Inc., 220 W. 42nd St., New York.

Centaur Film Co., 670-682 Ave. E, Bayonne, N. J.

Evans Film Mfg. Co., 412-22 W. 216th St., at Broadway, New York.

Gunby Bros., Inc., 145 W. 45th St., New York.

Industrial Moving Picture Co., 223-233 W. Erie St., Chicago.

Standard Motion Picture Co., 5 S. Wabash Ave., Chicago.

Standard Filmprint Corp., 120 School St., Yonkers, N. Y.

FILM REELS

Lang Mfg. Works, Olean, N. Y.

Taylor-Shantz Company, 224 Mill St., Rochester, N. Y.

FURNITURE AND FURNISHING ON RENTAL

William Birns, 103-105 West 37th St., New York.

FEATURE FILMS

Alco Film Corp., 218 W. 42d St., New York.

Alliance Films Corp., 126 W. 46th St., New York.

Albuquerque Film Mfg. Co., Inc., 406 Court St., Los Angeles, Calif.

All Star Feature Corp., 220 W. 42d St., New York.

Ambrosio American Co., 15 E. 26th St., New York.

Bosworth, Inc., 648 South Olive St., Los Angeles, Cal.; New York office, 440 Fourth Ave.

Box Office Attraction Film Rental Co., 130 W. 46th St., New York.

Blinckhorn Photoplays Corp., 110 W. 40th St., N. Y.

California Motion Picture Corp., San Francisco, Cal.

Cosmofotofilm Co., 110 W. 40th St., New York.

Cosmos Feature Film Corp., 126-130 W. 46th St., New York City.

Direct-From-Broadway Features Co., 46 W. 24th St., New York.

Eclair Film Co., 126 W. 46th St., New York.

Eclectic Film Co., 110 W. 40th St., New York.

Excelsior Feature Film Corp., Inc., 110 W. 40th St., New York.

Favorite Players Film Co., 110 West 40th St., New York.

Features Ideal, 126 W. 46th St., New York.

Famous Players Film Co., 213-229 W. 26th St., New York.

Films Lloyds, Inc., 220 W. 42nd St., New York.

G. W. Feature Film Corp., 145 W. 45th St., N. Y.

General Film Co., 200 Fifth Ave., New York.

General Feature Film Co., 313 Mallers Bldg., Chicago, Ill.

Gaumont Co., 110 W. 40th St., New York.

Greene's Feature Photo Plays, Inc., 110 W. 40th St., New York.

W. W. Hodkinson, 110 W. 40th St., New York.

Imperial Motion Picture Co. of N. Y., Inc., 1476 Broadway, New York.

Inter-Continent Film Co., 110 W. 40th St., N. Y.

George Kleine Attractions, 166 N. State St., Chicago, Ill.

New York Office: 1476 Broadway.

Jesse L. Lasky Feature Play Co., Longacre Theatre, New York.

Life Photo Film Corp., 220 W. 42nd St., N. Y.

Mecca Feature Film Co., Inc., 126 W. 46th St., New York.

Mohawk Film Co., Times Bldg., New York.

Oz Film Mfg. Co., Santa Monica Blvd., Los Angeles, Cal.

Paramount Pictures Corp., 110 W. 40th St., N. Y.

Phoenix Feature Film Corp., 129-131 Columbus Ave., Boston, Mass.

Photo Play Production Co., 220 W. 42nd St., N. Y.

Picture Playhouse Film Co., 110 W. 40th St., New York.

Playgoers Film Co., Lyric Theatre, New York.

Popular Plays and Players Co., 1600 Broadway, New York.

Progress Film Co., 110 W. 40th St., New York.

Progressive Motion Pictures Corp., Times Bldg., New York.

Ramo Films, Inc., Columbia Theatre Bldg., N. Y.

Rolands Feature Film Co., 145 W. 45th St., N. Y.

A. H. Sawyer, Inc., 1600 Broadway, New York.

Select Photo Play Producing Co., Inc., 71 W. 23rd St., New York.

Sterling Camera & Film Co., 145 W. 45th St., New York.

Solax Co., Fort Lee, N. J.

The Masterpiece Film Mfg. Co., 1111 Van Nuys Bldg., Los Angeles, Cal.

The Balboa Amusement Producing Co., Long Beach, Cal.

The Photoplay Productions Releasing Co., 37 S. Wabash Ave., Chicago, Ill.

Union Features, 126 W. 46th St., New York.

Universal Film Mfg. Co., 1600 Broadway, N. Y.

University Films, Inc., 110 W. 40th St., N. Y.

Edw. H. Wagner, Agt., Dania Biofilm Co., 38 Park Place, New York.

World Film Corporation, 130 W. 46th St., N. Y.

Warner's Features, Inc., 130 W. 46th St., N. Y.

LANTERN SLIDE MATS AND REEL BANDS

Lantern Slide Mat Co., 149 W. 35th St., N. Y.

LABELS

Every Ready Roll Label Co., 203-7 W. 40th St., New York City.

LIGHTING PLANTS

Cushman Motor Works, Lincoln, Neb.

LOBBY PHOTOS

The Wyanoak Pub. Co., 136 W. 52nd St., N. Y.

MOTION PICTURE MACHINES AND SUPPLIES

Amusement Supply Co., 160 E. North Fifth Ave., Chicago, Ill.

Behrend Motion Picture Supply House, 440 Fourth Ave., New York.

Calehuff Supply Co., 1301 Race St., Philadelphia, Pa.

Enterprise Optical Co., 568 W. Randolph St., Chicago, Ill.

Lears Theatre Supply Co., Sam Lears, Prop., 509 Chestnut St., St. Louis, Mo.

Oliver Moving Picture Supply Co., 647 Euclid Ave., Cleveland, O.

Picture Theatre Equipment Co., 21 E. 14th St., New York.

Precision Machine Co., 317 E. 34th St., N. Y.

Nicholas Power Co., 90 Gold St., New York.

The Phantoscope Mfg. Co., Washington, D. C.

Sweeley's Photo Supply House, 514-516 Erie Ave., Renova, Pa.

Williams, Brown & Earle, Inc., 916-918 Chestnut St., Philadelphia, Pa.

MOTION PICTURE APPARATUS

Burke & James, Inc., 240-258 E. Ontario St., Chicago, Ill.

MUSICAL INSTRUMENTS

American Photo Player Co., 62 W. 45th St., N. Y.

Rudolph Wurlitzer Co., Cincinnati, O.

OPERA CHAIRS

The Hardesty Mfg. Co., Canal Dover, Ohio.

Steel Furniture Co., Grand Rapids, Mich.

POSTER AND PICTURE FRAMES

Menger & Ring, 442 W. 42nd St., New York.

Newman Mfg. Co., 717 Sycamore St., Cincinnati, O.

PIPE ORGANS

Henry Pilcher's Sons, 914-920 Mason Ave., Louisville, Ky.

M. P. Moller, Hagerstown, Md.

PROJECTION LENSES

Bausch & Lomb Optical Co., 569 St. Paul St., Rochester, N. Y.

POSTERS

The Morgan Lithograph Co., Cleveland, Ohio.

RAW FILM

Eastman Kodak Co., Rochester, N. Y.

Celluloses Planchon, Inc., 75 Fifth Ave., N. Y.

David Horsley, 1600 Broadway, New York.

Raw Film Supply Co., 15 E. 26th St., New York.

REWINDERS AND GENERAL SUPPLIES

L. C. Smith Co., Schenectady, N. Y.

SCREENS

Atsco, Inc., 218 West 42nd St., New York.

Day & Night Screens, Inc., 110 W. 40th St., N. Y.

Mirror Screen Co., Inc., Shelbyville, Ind.

STEEL FILM EQUIPMENT FOR EXCHANGES AND MFERS.

Columbia Metal Box Co., 226-228 E. 144th St., New York.

TICKETS—ROLL AND COUPON

Rees Ticket Co., 400 S. 10th St., Omaha, Neb.

THEATRE LOBBY FRAMES AND FIXTURES

Newman Mfg. Co., 715 Sycamore St., Cincinnati, O.

UNIFORMS

Fechheimer Bros., Union-made Uniforms, Cincinnati, O.

VENTILATION, COOLING AND HEATING

Typhoon Fan Co., 1544 Broadway, New York.

"THE ADVENTURES OF GAR EL HAMA"

An Exciting, Spectacular Melodrama
In Four Parts

TEEMING WITH THRILLS

Featuring the Distinguished European Dramatic Star,
A. HERTEL

AN ELABORATE PRODUCTION OF A ROMANTIC,
INTEREST-COMPELLING STORY

STARTLING SITUATIONS, STIRRING CLIMAXES,
EXCEPTIONALLY PICTURESQUE SCENERY
NOVEL AND WONDERFUL PHOTOGRAPHIC EFFECTS

STATE RIGHT MEN!!!

Gar El Hama Is Here Again, and Better
Than Ever. He Made Money for You
Before. He Will Do It Again.

Ready Now Order Quickly

UNUSUAL LITHOGRAPHS

In Ones, Threes and Six Sheets. Attractive Heralds,
Photographs and Slides

MAKE NO MISTAKE!!!

**THIS FEATURE WILL BE A GREAT
MONEY-MAKER!!!**



GREAT NORTHERN FILM COMPANY

110 West 40th St.
NEW YORK

Day and Date	Titles of Films Booked	Release Date	Brand	No. Reels	Review appears in MOTION PICTURE NEWS of		Posters Used and Size	Regular or Special	Cost	Advertising Used: Newspapers, heralds, slides, photographs, window cards	Weather	Total Admissions	
					Issue	Page						Matinee	Night
MONDAY													
												Remarks	
TUESDAY													
												Remarks	
WEDNESDAY													
												Remarks	
THURSDAY													
												Remarks	
FRIDAY													
												Remarks	
SATURDAY													
												Remarks	
SUNDAY													
												Remarks	

Cosmofotofilm Co



London Film Co.
(Trade Mark)



London Film Co.
(Trade Mark)

"Where the REAL FEATURES come from"

Announces two IMMINENT Releases:

"THE VICTORIA CROSS" (3 Parts)

(Copyright 1914)

A Thrilling story of Heroism on the Battle-front (Neutral)
WRITTEN AND PRODUCED BY ANNE AND BANNISTER MERWIN
Featuring

Edna Flugrath, Charles Rock, Ben Webster and Gwynne Herbert

Filmed by the London Film Company, Ltd.

(Producers of "THE HOUSE OF TEMPERLEY" (Conan Doyle), "ENGLAND'S MENACE," "ENGLAND EXPECTS—," "SHE STOOPS TO CONQUER," "FOR HOME AND COUNTRY," "CALLED BACK," "THE BOSUN'S MATE," "LAWYER QUINCE," "THE THIRD STRING," "BEAUTY AND THE BARGE," etc.), and also

"THE BLACK SPOT" (4 Parts)

(Copyright 1914)

One of the most thrilling and most cleverly enacted Dramas ever filmed by the London Film Company

PRODUCED BY HAROLD SHAW

Featuring

Jane Gail, Charles Rock, Stella St. Audrie and other Stars

EXHIBITORS!!!

ONCE MORE WE REMIND YOU THAT

OUR TWO CHRISTMAS FILMS

"THE TWO COLUMBINES" and "A CHRISTMAS CAROL"

(2 REELS)

(1 REEL)

(Both filmed by the famous London Film Company, Limited)
can now be booked in advance through The Exchanges of the

PARAMOUNT PICTURES CORPORATION

If any difficulty is experienced in booking, address
World Tower Building, 110-112 West 40th St., New York



Cosmofotofilm Co

Be sure to mention "MOTION PICTURE NEWS" when writing to advertisers.

"THE TRUTH WAGON"

Produced by Masterpiece Film Mfg. Co., in Five Reels

FROM THE PLAY BY HAYDEN TALBOT, FEATURING

Mr. MAX FIGMAN
and **MISS LOLITA ROBERTSON**

Released December 14

CURRENT RELEASES

THE KEY TO YESTERDAY

From the Novel by Charles Nevil Buck
with **CARLYLE BLACKWELL**

THE PATH FORBIDDEN

From the Novel by John Hymor
with **OCTAVIA HANDWORTH**

AT THE OLD CROSS ROADS

From Arthur C. Aistons' famous play
with **ESTHA WILLIAMS**

THE HOOSIER SCHOOLMASTER

From the great American Story by Edw. Eggleston
with **MAX FIGMAN**

THE MAN WHO COULD NOT LOSE

By Richard Harding Davis
with **CARLYLE BLACKWELL**

WHEN FATE LEADS TRUMP

From Novel by Alice M. Roberts
with **OCTAVIA HANDWORTH**

FORTHCOMING RELEASES

HEARTS AND FLOWERS

From the celebrated play of the same name
with **MRS. THOMAS WHIFFEN**

THE LAST EGYPTIAN

From the book by L. Frank Baum
with **FARRELL McDONALD** and **VIVIAN REED**

THE LAST CHAPTER

By Richard Harding Davis
with **CARLYLE BLACKWELL**

THE TRUTH WAGON

From the play by Hayden Talbot
with **MAX FIGMAN**

EXCHANGES

- ALLIANCE FILM SERVICE, 115 Fourth Ave., Pittsburgh, Pa. A. A. Welland, Mgr. *Ohio, Western Pennsylvania, Kentucky and West Virginia.* (Kentucky exhibitors will be served from Cincinnati office after Dec. 1.)
- ALL THEATRES, FILM AND ACC. CO., INC. Owners of Alliance Film Exchanges, New York State. Buffalo Office, 18 Chapln Block; S. S. Webster, Mgr.; I. Cobe, Gen. Rep. New York City Office, 126 West 46th St.
- ALLIANCE FILM SERVICE, controlled by Eastern Feature Film Co., Inc., 57 Church St., Boston, Mass. *New England*
- ALLIANCE FEATURE FILM SERVICE, controlled by Mecca Feature Film Co., 130 West 46th St. *Northern New Jersey.*
- ELECTRIC THEATRE SUPPLY CO., Vine and 13th St., Phila., Pa. *Southern New Jersey, Eastern Pennsylvania, Maryland, Delaware, District of Columbia.*
- APEX FEATURE SERVICE, 311 Andrews Bldg., Dallas, Texas. M. Levson, Mgr. *Texas, Arkansas and Oklahoma.*
- APEX FEATURE SERVICE, 417 Rhodes Building, Atlanta, Ga. O. P. Hall, Mgr. *Virginia, North Carolina, South Carolina, Georgia, Florida, Alabama, Mississippi, Louisiana.*
- CASINO FEATURE FILM CO., Dime Savings Bank Bldg., Detroit, Mich. *Michigan.*
- CELEBRATED PLAYERS FILM CO., 64 West Randolph St., Chicago, Ill. *Illinois and Indiana.*
- NAT A. MAGNER CO., Pacific Bldg., San Francisco, Calif.; 218 Superba Theatre Bldg., Los Angeles, Calif. *California, Nevada and Arizona.*
- DES MOINES FILM SUPPLY CO., 218 Utica Bldg., Des Moines, Ia. *Iowa.*
- MONARCH FEATURE FILM CO., 12th and Wyandotte Sts., Kansas City, Mo. *Missouri, Kansas and Nebraska.*
- ZENITH FEATURE FILM CO., Lyceum Bldg., Duluth, Minn. *Minnesota, North and South Dakota and Wisconsin.* Milwaukee Office, 407 Manhattan Bldg.
- ALLIANCE FILM SERVICE, Controlled by Noted Players Feature Film Co., 613 New Birks Bldg., Montreal. Jas. D. Goldie, Gen. Mgr., *Canada.*
- ALLIANCE PROGRAMME FEATURE SERVICE. Exchanges located at 710 Northwestern Bank Bldg., Portland, Ore.; 1214 Third Ave., Seattle, Wash.; 809 Trent St., Spokane, Wash.; 27 N. Park St., Butte, Mont.; 607 Ideal Bldg., Denver, Col. Supplying States of Washington, Oregon, Montana, Idaho, Wyoming, Colorado, Utah, and New Mexico.

ALLIANCE FILMS CORPORATION

TIMELY WORDS

The announcement of the Alliance Program was somewhat of a surprise to the trade in general.

Not so, however, to those who knew the many months of patient labor spent in crystallizing the scheme and in building the machinery of the gigantic organization.

The wheels have been turning since the 12th day of October, increasing in velocity and speed, until today the Alliance stands forth a tower of strength, and is growing stronger every day.

The advertising of the Alliance has been honest. No false promises have been made. No wild statements of financial backing have been disseminated. What difference does it make to the exhibitor if plain Jim Smith or a high sounding financial name is behind a company? The exhibitor's only interest is the picture on the screen, and the sole aim of the Alliance Films Corporation is to place on its program the best feature films that can be had, and it has done so.

The Alliance Films Corporation is not hampered or controlled by any manufacturing company. It reserves the right to buy film on the screen, and it sets the standard for its film productions.

This plan has the complete approval of such manufacturers as are sincere in their determination to produce good film and really put the money into them.

The quality of the productions will increase steadily. It must not be forgotten that the Alliance Program was launched in the midst of certain conditions existing in the trade, and that it has steadily pulled away from these conditions. It has accomplished wonders in a very short time, and in the near future will stand apart and alone,—and unquestionably the best program in the world.

Future announcements will show that the biggest and best things in filmdom are being done in the Alliance ranks, and that the exhibitor handling the Alliance Program will have reason to congratulate himself.

A. J. COBE, General Manager.

126 W. 46th St.

LEAVITT
BLDG.

New York City

THE MASTERPIECE FILM MFG. CO.
 PRESENTS
MR. MAX FIGMAN
 SUPPORTED BY
 MISS LOLITA ROBERTSON *in*
The **TRUTH WAGON**
 (5 REELS)



A comedy-drama adapted from the play
 BY HAYDEN TALBOT
 Produced under the personal direction of
 Mr. Figman, who collaborated with Mr.
 Talbot in the writing of the play, and
 for whom the play was especially written

ON ALLIANCE PROGRAM DEC. 14

MASTERPIECE FILM MFG. CO.

1111 Van Nuys Bldg.

Los Angeles, Cal.

MAX FIGMAN, General Director

WESTON



making you
 a Merry and
 May the New Year find you
 The Man Who Could Not Lose
 Carlyle Blackwell

FAVORITE PLAYERS FILM CO.
 PRODUCERS OF
 "THE HEY TO YESTERDAY"
 "THE MAN WHO COULD NOT LOSE"
 "THE LAST CHAPTER"
 ALLIANCE PROGRAM



STATE RIGHT BUYERS



A few territories still left unsold on each of our 5 part dramatic masterpieces

- "The Banker's Daughter"by Bronson Howard
 "The Greyhound"by Paul Armstrong and Wilson Mizner
 "Northern Lights"by Barbour and Harkins
 "Capt. Swift"by C. Haddon Chambers
 "The Ordeal"an adaptation

All future releases are controlled by the Alco Film Corporation

Exhibitors: New York State and New Jersey can book "Capt. Swift" and "Northern Lights" direct through our executive offices

Beautiful lithographs, heralds and other advertising matter

Samples forwarded on request

Advise us of your territory interested in, and we will wire our terms

LIFE PHOTO FILM CORPORATION

Executive Offices
220 West 42nd St., New York
Phone, Bryant 7852

Studio and Laboratory
Grantwood, N. J.
Phone, Cliffside 323

Perfect Laboratory Work Is as Essential to Perfect Pictures as Photography, Acting or Story

With our superior laboratory, constructed to meet every requirement of the trade, we guarantee all work intrusted to us.

Our prices based on perfect work.

Developing Negative, 1c. per foot

Printing Positive, 4c. per foot

Including Tinting and Toning

Others may quote lower figure, but as a rule "what is cheap, is dear."

COMMERCIAL MOTION PICTURES CO., Inc.

Laboratory, Grantwood, N. J. Phone, Cliffside 323

Executive Offices, 220 West Forty-second Street, New York City Phone, Bryant 7852

"THERE IS SENSATIONAL BOX OFFICE INTEREST IN 'THREE WEEKS,' "A VARIETY. "VIVID IN INTEREST AND GIVES NO OFFENSE."—N. Y. HERALD. "WILL SWEEP THE COUNTRY."—EVG. MAIL. "APPLAUSE LASTED SEVERAL MINUTES."—MORNING TELEGRAPH. "AWAKENED A FUROR OF INTEREST."—MOTION PICTURE NEWS. "ESTIMATED COST OF PRODUCING THE PICTURE IS \$83,000."—DRAMATIC MIRROR. "ONE OF THE MOST ATTRACTIVE PICTURES SHOWN IN NEW YORK IN A LONG, LONG TIME."—CLIPPER. "A WONDERFUL PICTURE."—N. Y. STAR. ETC., ETC., ETC.

PASSED BY THE NATIONAL BOARD OF CENSORSHIP!

LAST CALL, \$TATE RIGHT\$ HURRY UP CALL, RENTAL\$
GOOD BYE TO OPTION\$ NOTHING \$UCCEED\$ LIKE \$UCCE\$\$
THE FUROR PHOTO-PLAY \$EN\$ATION

B. S. MOSS' EXQUISITE PRODUCTION OF
ELINOR GLYN'S EPOCH MAKING LOVE DRAMA

"3 WEEKS"

IN FIVE PARTS

ONLY AUTHORIZED VERSION. ALL INFRINGEMENTS PROSECUTED.

\$68,503.00 Sold from First Advertisement

Chicago and State of Ill., with Middle
Western States, to Jones, Linick and
Schaefer **\$20,000**

SOLD San Francisco and
all California for **\$10,000**

BOUGHT BY SIDNEY HARRIS, SAN FRANCISCO, CAL.

SOLD New York City and
New York State for **\$12,000**

BOUGHT BY THE AMALGAMATED PHOTO FEATURE BOOKING CORP., NEW YORK, N. Y.

(1 Print Only for Each State. Extra Prints, \$500 additional)

BIDS Ohio, \$2,000. Holding for \$3,000. New Jersey, \$1,500. Holding for \$2,500. Penn-
sylvania, \$4,000. Holding for \$5,000. Ten Southern States, including Texas, \$8,000.
Holding for \$12,000, or selling separately at \$800 to \$1,500 each.

Will Ourselves Take 50 Per Cent. Interest in Any of This Territory With Experienced,
Live Business Getters.

Will Turn Over to All States Buyers Thousands of Dollars in Rental Offers Already
Received After Film Is Exhausted As An Exhibition Show Feature.

FIRST PRINTS READY FOR SHIPMENT DEC. 1 FIRST RELEASES IN NEW YORK DEC. 1

Beautiful Line of Illuminated Art Posters. 24 Sheets 2 kinds; 6 Sheets 2
kinds; 3 Sheets 2 kinds; 1 Sheet 3 kinds

ALSO ANIMATED TWO-TONE ADVANCE PICTORIAL HERALDS

WRITE!!

PHONE!!

WIRE!!

B. S. MOSS

RELIABLE FEATURE FILM CORPORATION

Columbia Theatre Building, Broadway and 47th Street, New York



THE ALBUQUERQUE

FILM MANUFACTURING CO., Inc.

LUNA BRAND

Two Comedies Weekly, Featuring

Miss Dot Farley

Releasing Through

**THE UNITED MOTION PICTURE
PRODUCERS, Inc.**

Who Distribute Through

UNITED FILM SERVICE

(Warner's Features, Inc.)

Releases

- Nov. 12—REUBEN'S BUSY DAY
 " 19—THE SAGE BRUSH LEADING LADY
 " 26—SOUL MATES
 Dec. 3—A MOUNTAIN GOAT
 " 10—SHOT IN THE FRACAS
 " 17—FINISHED AT SEA
 " 17—RURAL ROMEO'S
 " 24—HIS NEIGHBOR'S PANTS
 " 24—THE CHASER
 " 31—THE BIG STICK
 " 31—TOO MANY WIVES
 Jan. 7—WITH DADDY'S AID

Farce Comedy Production

By

ARCHER McMACKIN

With Years of Success with the Essanay

Watch for Pleasant Surprises

Under Direction of

GILBERT P. HAMILTON

Pres. and Gen. Mgr.

OFFICE AND STUDIO

406 Court St., Los Angeles, Cal.



"THE SERUM OF REASON"

(Leading Players-Warners—Four Reels)

REVIEWED BY H. S. FULD

A RATHER interesting offering, in that, while the plot might seem to some rather farfetched, it holds the interest of the spectator throughout. The cast in this release is one of exceptionally good choosing and though there are only four principals there is a number of minor roles well taken care of.

It seems that special attention must have been given to the acting of this story by the director, and the result is a smoothness and celerity that make the scenes in this production more "real" than the average.

More than the usual attention would also seem to have been given the exteriors, on board the steamer and on the grounds of the laboratory; and the interiors, especially the close-ups, are wonderful examples of good clear photography.

Doctor Landay (Raymund Fabre) in a laboratory discovers a new serum which when used right by any physician, is a preventive of madness. The secret of his discovery is known to his two assistants, both of whom are in love with the doctor's daughter Jennie (Renee Sylvaire).

The one, Jude (Henri Guuget), plots to discredit the other, Frank Ferndale (G. Tramont), in the eyes of the doctor and his daughter, by disclosing the secret to a newspaper in a communication signed with the other's name. The plot succeeds and the discredited one leaves for Africa.

Jude succeeds after numerous efforts in incarcerating Jennie and her father in a sanitarium, while he proceeds to enjoy his ill-gotten gains, and the father and daughter soon go insane.

Jennie's maid succeeds in getting word to Frank in Africa, and he hurries back. By contriving to gain admittance to the sanitarium by impersonating a nurse, the maid is enabled to get access to both the imprisoned ones. Frank, by a cleverly executed night raid on the laboratory, secures the serum and gives Jennie and her father a dose. Both recover their reason, and Jude, discovering that his duplicity is known, goes mad himself and is taken to the same asylum the two so recently left.

Everything is cleared up to the satisfaction of everyone and Frank marries Jennie. A good offering and is bound to please.

"LITTLE GIRL THAT HE FORGOT" FOR STATE RIGHTS

THE coming release of the Cosmos Feature Film Corporation, featuring Beulah Poynter in her own play "The Little Girl That He Forgot," in five parts, will be marketed as a state right proposition. Arthur H. Jacobs, vice-president of the above mentioned concern, left for Chicago on December 4, and from latest advices received, the disposal of prints is going on rapidly.

"The Little Girl That He Forgot" is a tale of intense heart interest, full of thrills, not spectacular, but of the human order. The acting is most capable, the photography excellent and from a scenic standpoint the production is beautiful. There is little doubt that the value of a feature of this order will be much appreciated by the masses.

Any story that is true to life and that is well depicted generally meets with success when screened. Joseph A. Golden, who directed the film version of "The Little Girl That He Forgot" needs no introduction; his past performances speak for themselves. Those that have seen "The Little Girl That He Forgot" predict for it great success.

850 CAPACITY THEATRE FOR GEORGIA TOWN

Special to MOTION PICTURE NEWS

Atlanta, Ga., Dec. 9.

COLUMBUS, Georgia, is to have by the middle of January a new theatre which, it is said, will be the most splendidly equipped in the city. Roy E. Martin and H. L. Wood have just closed a deal by which Mr. Martin has leased the property at 1131 and 1133 Broad street for ten years. He announces that he will erect there one of the largest motion picture houses in the Southeastern part of Georgia.

Mr. Martin plans to have plenty of exhaust fans, rest rooms and various comforts, and states that the ceiling will be high and the rows of seats 37 inches apart. The theatre will have a balcony that will seat 200 and an auditorium with a seating capacity of 650.

Paramount pictures will be shown in the new theatre, according to Mr. Martin.

PERFECT DEVELOPING AND PRINTING

FOR AMATEURS AND PROFESSIONALS IN ANY QUANTITIES

WE GUARANTEE QUALITY PLUS PROMPT DELIVERY AND PERSONAL SERVICE

Our unexcelled facilities, complete factory equipment, special service bureau, combined with our experience and successful record extending over a period of more than four years, qualifies us to best serve you.

PRICES, REFERENCES AND FACTORY DESCRIPTION SENT AT YOUR REQUEST

WE SUPPLY FRESH EASTMAN NEGATIVE

to our customers as a matter of accommodation, and guarantee to make shipment same day order is received. All film stock guaranteed highest grade with perfect Bell & Howell perforations.

INDUSTRIAL MOVING PICTURE COMPANY

WATERSON R. ROTHACKER, Gen. Mgr.

223-233 WEST ERIE STREET

CHICAGO

Save Five Days!

This time given to your producing company will make it possible for them to improve the product —Why is this not better than having the film tied up that time in transit.

Our laboratories, though new, are in charge of old heads in the business, who know the HOW of getting best results from the raw exposed negative film, and they are NOW doing it for some of the greatest producers of today.

We want an opportunity to prove that our work cannot be surpassed. Few, if any, can equal it.

INTERNATIONAL Laboratories

Phone West 792

3123-25 South Hoover St.

Los Angeles

MR. EXHIBITOR:

And all others interested in Motion Pictures:

It will be to your interest as well as to my interest, for you to investigate the line of

Cameras **Tripods**
Printers **Film Meters**

and other studio equipment handled by me.

The line is complete.

Yours for better pictures,

Carl (E. Fr.) Sternlov

291 E. Washington Street, Los Angeles

Motion Pictures to Order, Developing and Printing.

Compliments of the Season

To Our Friends

Developing and Printing Laboratories

of

Evans Film Manufacturing Co.

416-24 West 216th Street

Phone 6881-6882 Audubon

New York

WARNING

“All releases of Keystone films are now being copyrighted. All infringers and ‘dupers’ will be apprehended and punished to the extent of the law.”

THE KEYSTONE FILM COMPANY

A. KESSEL, JR., President

Longacre Building, Broadway and 42nd Street

NEW YORK CITY

ALWAYS

Draw the Crowds

RENFAX MUSICAL MOVIES

NEED NO SINGER

Cheap enough for the smallest house.

Good enough for the largest.

Hundreds using service every week.

RENFAX FILM CO., Inc.

NEW YORK: 110 West 40th St. CHICAGO: 154 West Lake St.

PITTSBURGH, PA.: 417 Fourth Avenue

“The final measure of a magazine’s success is the INCREASE in the amount of advertising it carries.”

Christmas 1913 “News” 15,524 lines.

Christmas 1914 “News” 39,260 lines.

**An increase of
23,676 lines—153%.**

ONE YEAR AGO a lightning success such as this was not believed possible.

TODAY the “News” has proved it.

ONE YEAR FROM NOW this lightning success will have been repeated.

THIS YEAR—DON’T WAIT FOR THE “NEWS” TO PROVE IT TO YOU AGAIN.

BETTER LIGHT

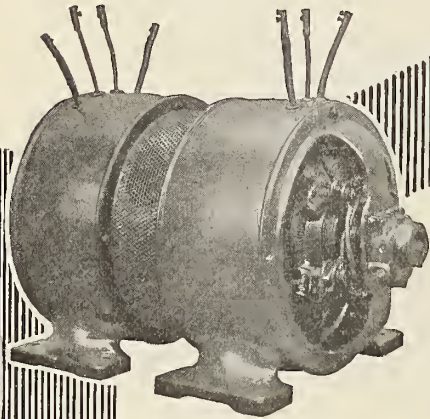

The DC Compensarc lowers the voltage of a direct current supply to that required at the lamp without needless waste.

LESS CURRENT

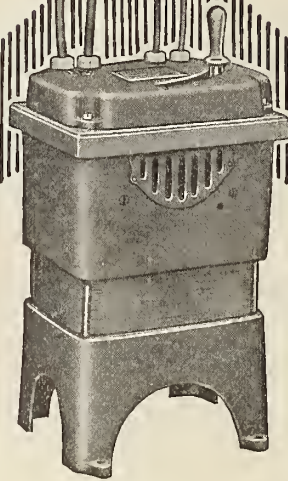

The AC Compensarc cuts $\frac{2}{3}$ from your lighting bill if you use alternating current.

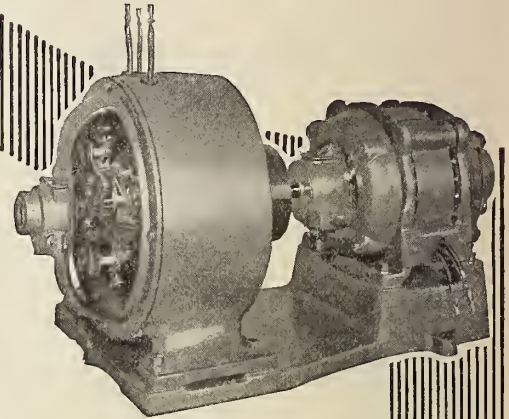

The AC to DC Compensarc will transform alternating into direct current and reduce the voltage at the same time without needless waste.

No matter what current you have---Alternating or Direct---or what voltage or frequency, one of the

FORT WAYNE COMPENSARCS

will enable you to secure a light that will give those clear, bright pictures that everybody now demands.

What's the use of paying extra money for special screens, projecting machines, and first run films and then spoil the whole result with poor light? With the Fort Wayne Compensarcs you can get any kind of light you want regardless of the kind or quality of your current supply.

The Compensarcs will give you

STEADY LIGHT. No flickering, no sputtering, even when changing intensities or from one machine to another.

WHITE LIGHT. No yellow streaks, no ghosts.

BRIGHT LIGHT. Three times the light with two-thirds the current.

They are safe, efficient, easy to operate, fool proof and reliable.

FORT WAYNE ELECTRIC WORKS

OF GENERAL ELECTRIC COMPANY

1704 BROADWAY

FORT WAYNE, INDIANA

Compensarcs are so commonly found in motion picture theatres that many people now call all current saving and transforming devices by that name.

But Remember

*If it isn't a FORT WAYNE
it isn't a "COMPENSARC"*



*Send TODAY for this
FREE descriptive booklet*

DECEMBER 19, 1914

Accessory News

THE CONSTRUCTION, EQUIPMENT AND OPERATION OF THE MODERN PICTURE THEATRE
VOLUME X NUMBER 24

SHOW YOUR APPRECIATION TO YOUR PATRONS

PRESENT THEM WITH A PHOTO OF THEIR FAVORITE STAR
A MOST ACCEPTABLE XMAS REMEMBRANCE

Write

for
Catalogue
and
Price List

To-day



Florence Lawrence



Mary Fuller



Wallie Van

Ask Us

about our
Two Plans
Designed
to Increase
your

Receipts

If your patrons desire our elaborate Hand-colored Photos, take their order and we will fill it with a special discount to you.

First Ask Your Exchange or Dealer

WYANOAK PUBLISHING CO.
136 WEST 52d STREET NEW YORK CITY

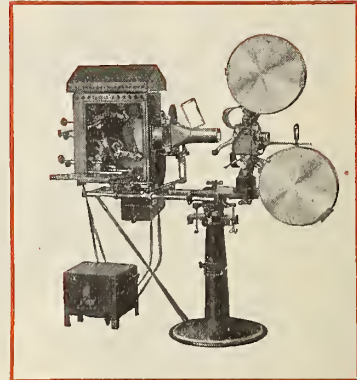
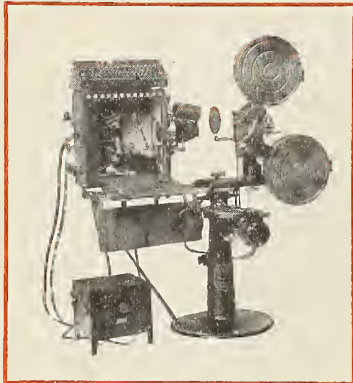

MOTIOGRAPH

Projectors are years in advance of the many motion picture machines. The inside shutters will enable you to get a brighter picture at twenty amperes than other machines at thirty amperes. Did you ever stop to think what you will save in twelve months by using less current? It will be more than enough to buy a new motion picture machine—and this is not all. Think of the steel bushings, the sprockets, steel star and cam, hardened and ground, which will insure accuracy and rock steady pictures, and besides this a very wonderful saving in repair parts. This is not a mere statement but facts that have been proven. The Motiograph has been tried year after year, and every user will tell you of its superior projections and wonderful wearing qualities. So if you want a machine that will give long life and small upkeep, why not buy a Motiograph.

Send for the latest catalog of the

MOTIOGRAPH

Enterprise Optical Manufacturing Co.

568 W. Randolph St.
CHICAGO

Eastern Office, 19 W. 23rd St.
New York

Western Office, 833 Market St.
San Francisco

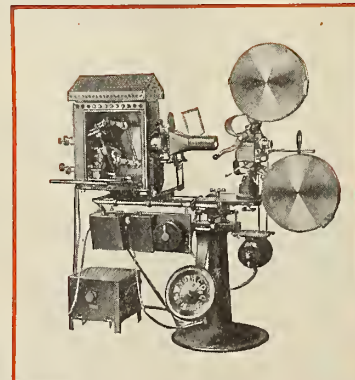

Construction,
Equipment
and Operation

Accessory News

Everything for
the Modern
Picture Theatre

TEL. 7650 BRYANT

TWO HUNDRED AND TWENTY WEST FORTY-SECOND STREET

NEW YORK CITY

Volume X

DECEMBER 19, 1914

Number 24

OLD FILMS MADE NEW BY A SPECIAL PROCESS

Good Will of a Theatre, a Vital Quality Depending on the Pictures More Than Anything Else, Can Be Maintained Only Through a Proper Supervision of the Service—Celluloid, Affected by Fluctuations of Temperature and Other Causes, Loses Transparency

THE good will asset of a moving picture theatre, or, in other words, the property created in establishing good will for such a theatre is purely psychological. The good will consists solely of the mental attitude toward the theatre which is found in the minds of the general public from which the patrons of the theatre come. The good will takes the form of, or tendency, or inclination to patronize the theatre and a predisposition to derive pleasure and satisfaction from the patronage.

Good will for a motion picture theatre manifests itself in the favoring attitude of the public toward the theatre. People who have the favoring attitude toward a theatre are less critical of its service and are more easily satisfied with the films which are shown. People who are animated by good will are looking for satisfaction. They are in a state of expectant attention which leads them to overlook defects and to see and magnify merits.

The good will created for a theater grows from the pleasure and satisfaction which are regularly experienced by those who view the pictures shown there. One who uniformly experiences pleasure and satisfaction in viewing the films exhibited in a certain theatre becomes favorably disposed toward that theatre. When such a person desires to go to a picture show, he will make it a point to go to the place which his past experience has shown him to have regularly a satisfactory film service.

Attractive exterior and interior finishing, comfortable seating, lighting and heating, generous ventilation, cleanliness and courteous and efficient ushers contribute largely to the satisfaction of the patrons, but without good film service they are like the play of Hamlet with Hamlet left out. Films which give pleasure and satisfaction are the most important factor in making a regular patron out of the casual visitor. The chief endeavor of the exhibitor who wishes to create good will must be to secure the best quality of film service.

Good Film Service Essential to Patronage

The service of the film exchange which supplies the theatre creates good will for the theatre when the films it furnishes give such pleasure to the spectator that he feels inclined to visit the theatre again. Such a satisfied visitor becomes an advertising agent, as by his conversation he influences others to visit the theatre.

Good will for the film service rendered by the exchange will crystallize clearly and definitely in the mind of the man who manages the motion picture theatre, as experience shows him that the films furnished by the exchange please his patrons and to increase their number.

The manager of a motion picture theatre will naturally become a regular patron of an exchange that regularly furnishes him films of such quality that they attract a desirable class of people to become regular patrons of his theatre.

Good will must be continually renewed to keep it alive. When an exchange fails to give film service which satisfies the patrons of the theatre, it creates ill will for the theatre. Unsatisfactory service is a positive injury to the business and will cost too dearly, no matter how low the price. Whether an exchange service is creating ill will or good will for the theatres which use its films depends largely on the condition of the films it furnishes.

The wise exhibitor is looking out for a film service of such excellent quality that his patrons will leave the theatre cheered and invigorated. When he has shown good judgment in selecting which should please his patrons, it is very annoying for the exhibitor to find that his films are in such bad condition that they fail to give satisfaction.

The greatest bane of the film service is the tendency of films to become streaked and blurred with advancing age. The blotched and "rainy" appearance which a film takes on after it has been run a few times causes annoying eye strain to the patrons of the theatre. One leaves with a feeling of ill will and disgust for a place where he has been imposed upon with a film which is noticeably in bad condition. The desire to prevent such ill will and to gain and hold the good will of their patrons is responsible for the "age craze" among the exhibitors, and for their demand for films which have just been released.

The Causes of Bad Film Conditions

A film consists of a strip of celluloid which has been treated with an emulsion of gelatin containing photographic chemicals.

The exposure of the film to heat and light while it is being exhibited causes changes to take place in both the celluloid and the gelatin coating. The celluloid loses some of its transparency and becomes dry and brittle, so that it breaks easily. The moisture driven from the gelatin coating by the heat causes the film to shrink and curl, or warp, or buckle. A film in this condition produces unsatisfactory pictures and wears out rapidly.

When running a film the first time the gelatin coating of the film may adhere to the tension of the projecting machine and gather on it in small pointed masses. The pin-like points of these masses of gelatin adhering to the tension spring tend to cut the film and weaken the edge containing the sprocket holes. Insufficient oiling will cause the idlers to stick. In that case the gelatin adheres to the idlers and scratches the film in the center. Such scratches mar the beauty of the pictures.

A film "sweats" as the result of exposure to heat and to changing atmospheric conditions. This so-called "sweat" causes fine particles of carbon from the electric arc and particles of atmospheric dust to adhere to the film. The accumulation on the film of sweat and of opaque particles of dirt obstructs the transmission of light through the film. The loss of transparency is distributed irregularly over the film and gives it the blurred or blotchy appearance known as oil spots, or rain streaks. One who looks at the pictures produced by a film in such a condition finds it difficult to distinguish the various features and experiences a painful eye strain.

The dirt adhering to the film obstructs the transmitting light. A small opaque spot will be magnified many thousand times in the picture. A little dirt may cause very objectionable blurring. But this is not all. The sharp particles of dirt scratch and corrode the film as it is being wound and rewound. The adhering dirt thus causes a rapid deterioration of the film.

It must be evident to every film exchange man and every exhibitor of motion pictures that any process which will prevent or remove these causes of bad condition in films will prove of great value to the motion picture business.

(Continued on page 146.)

Projection

CONDUCTED BY HERBERT W. ANDEM

Operating a Projection Machine Scientifically

THE success of the Strand, New York, has been justly earned by the close attention given to the several factors making up the excellent performance seen at that theatre.

An important part of the supervision is good projection. Naturally, out-of-town exhibitors are much concerned in the high reputation this theatre has earned for itself, and want to know of some of the things that may be copied to assist them in making a success to their own theatres.



LESTER BOWEN

Those visiting New York City come directly to the Strand, and the operating room is one branch holding special interest to them; more so for the operators. For the benefit of those operators that cannot avail themselves of a visit, this article is written. Here we are going to see how good projection is obtained at the Strand.

Permission was given to visit the operating room by S. L. Rothapfel, managing director. His stage door attendant, wearing a neat gray and black

uniform, led the way from this entrance, back on the large stage, across to the passageway behind the proscenium boxes. Then up the aisle and stairways to the operating room, located at the top and back of the immense balcony.

This trip—and it was a trip indeed—impressed one with the “bigness” of this theatre building. More so than from entering on Broadway or the main lobby.

Small Projection Booth

Unfortunately, the architect did not design the operating room along the lines of “largeness” given to the rest of the building. It is the only small thing to be seen. It can be said in defense to this weak spot that the original idea was not to feature motion pictures. These were given as a forerunner to the regular theatricals to be started at the commencement of the winter season.

When the picture machine equipment arrived, some alterations were necessary to obtain sufficient head-room. All the more praise is to be given the operating force “delivering the goods” working in so limited a space within the operating room.

This booth is constructed of iron and concrete and is a part of the regular building. A vertical iron ladder fixed to the side wall forms the means of entrance to it. Entrance is first had to the rewinding room separated by a solid wall from the operating room. The floor space of this room is 16 feet by 9 feet, and a slanting roof of an average height of 10 feet, in the center of which is the ventilating outlet.

The ventilation is augmented in summer by an exhaust fan installed in this outlet. Also, the heat from within the lamp houses are led to this vent through a small diameter stovepipe. There is a large window located in the back wall, and this gives ample light during the day. This window also assists in good ventilation and in keeping the room temperature down in hot weather.

The projection is in charge of capable men who are thinking always of good projection, and endeavoring to do just one better than their brother operators are doing. They realize there are things to be learned, and exchange ideas freely on points of good projection. Lester W. Bowen is chief operator. His lieutenants are Jack Kieley and Walter Pichert. Their license cards to oper-



JACK KIELEY

ate machines are neatly framed under a glass cover, to protect them from soiling, and hang on a side wall.

The operating room equipment consists of two motor driven Simplex projectors having the new type large lamp houses. These machines are rigidly secured to the floor by means of bolts in the base of the pedestal. All the iron of the machines is electrically grounded to earth through a ground wire. This is required in New York in all booths having iron in its construction.

Use Two Simplex Machines

A very ingenious device is used on these machines termed “An automatic dowser.” With this device the projection is taken from one machine to the other without any interruption, the picture dissolving on the screen. The film reels have a capacity of 2,000 feet and 5-inch diameter hubs. Continuous projection can be maintained for any length of time. It is not necessary to announce part one or part two, etc., to photoplays in this theatre. The complete play is projected without interruption.

Another very good practice followed is to frame all films before projecting. The very objectionable view of two parts of pictures being seen by the audience while the operator is adjusting the framing is thus avoided. Also, it's a wise thing to start motor-driven outfits with the usual cranking handle.

This assures the machine starting immediately and prevents the belts slipping or stalling the motor. An iron box hung at a convenient place on the machine stand is used to put waste carbon stubs in until these are cooled down. A large wall-type clock, an intercommunicating telephone with the stage, musicians and manager, and a special call bell from the organ, used at rehearsals to stop projection while appropriate music is decided on, shows that conveniences have not been spared. A tool rack mounted on the wall is within reach of the operators and is liberally provided with tools.

Opera Glasses for Detection of Flams

To detect enemies of good projection, use is made of a pair of field glasses. It is to be remembered the screen in this theatre is 167 feet distant from the projectors. Any blurring from want of adjustment to the objective lens, or other defects in the pictures, can easily be seen through these field glasses by the operators and correction made without detection by the audience.

It all goes to show that GOOD PROJECTION means to give a picture to the audience without any indications of the workings of the machines, operators, or view back of the scenes, as it might be said. The audience sees a picture quietly and artistically appear on the screen and *stay there from start to finish*, with no indications of how it is being done. This constitutes GOOD PROJECTION.

Two very essential aids to the operator in giving good work is to have motor-driven machines and automatic feeding for the carbons. The operator can then give his attention to the smaller things necessary to his work. It has been expressed as having a one-handed man in the operating room when the machines are hand-operated only. It also compels this one-handed operator to remain in one position—a stationary post, to use a police term.

The Strand has both of these aids installed in the operating room. Sufficient light for the 16-foot x 19-foot Gold Fibre screen located back on the stage and reflecting a good picture to all parts of the house, seating 3,500 people, is had by using 70 to 80 amperes at 110 volts d. c., reduced by proper resistance. With this high current Bio carbons (cored) of $\frac{7}{8}$ -inch diameter for the



WALTER PICHERT

A clear picture

is as essential as a good scenario. Because the basic product is right the clearest pictures are on Eastman Film. Identifiable by the stencil mark in the margin.

EASTMAN KODAK CO.,
ROCHESTER, N. Y.

HOWELL SALES COMPANY

Motion Picture Equipment

711 First National Bank Building

CHICAGO, ILL.

Simplex Projector

Martin Rotary Converter

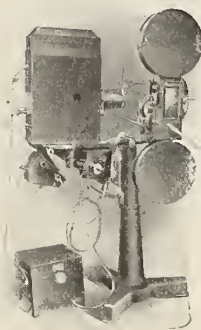

The SIMPLEX DE LUXE PROJECTOR

1915 Model now ready for delivery, equipped with the Kimble Variable Speed Motor Drive, with control on operating side of machine (A. C. only).

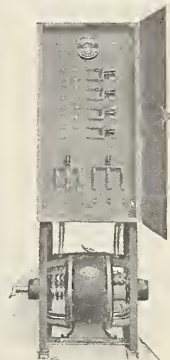

The MARTIN ROTARY CONVERTER

Three phase; Special Emergency Panel; permitting the use of alternating current through the transformer built into the machine, and thereby saving the usual cost of separate emergency resistance and the extra wiring incidental thereto (about two-thirds). The MARTIN ROTARY CONVERTER is a self-contained unit of high efficiency, producing pure white light from either 110 or 220 volt alternating current with a loss of less than twenty per cent. Average cost of current consumption 15 cents to 18 cents per hour of operation.

Architects and prospective theatre builders should consult our Engineering Department for valuable information on the correct designing of theatres for projection purposes.

Our Advisory and Maintenance Department is at your Service.

PROJECTION PROBLEMS ANSWERED

Troubles are continually coming up in every booth. Why not see whether the other fellow can help you? Our projection expert is ready and willing to answer any and all questions

WHICH YOU MAY ASK

Without obligation on my part please give me full advice on the following:

.....
.....
Name ..
Theatre ..
Address ..

Millions of Carbons

When the European war broke out, thousands of moving picture operators found themselves up against it.

They didn't know where their next supply of carbons was coming from.

We Supplied Them

Even though we had done little in this line, we got busy—worked our factory day and night. You know how we came across with the goods.

We Kept Thousands of Shows Open

The fact that we have shipped millions of carbons which have given splendid results, sold them at the right price—not speculators' prices—has meant money in your pocket. It's the best way we had of wishing you

Merry Christmas

NATIONAL CARBON CO.

CLEVELAND, OHIO

ATTENTION!

OPERATORS AND EXHIBITORS

You Use the Best Projector,
Why Not the Best Reel?

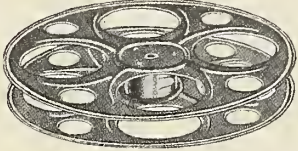

Our Improved Pat'd All-Steel 14-in. Reel. The strongest, the lightest, the most economical, the most efficient. Absolutely rigid rims with flanged edges. Readily accessible and "sure hold" threading device. White nickel finish.

Sent prepaid upon receipt of \$1.25 in New York Draft, Money Order or Cash.

**THE TAYLOR-SHANTZ
COMPANY**

222 Mill St., Rochester, N. Y.

Improve- ment

Is the Order
of the Age

OUR No. 2
CARBON
Economizer

Is the
Last Word

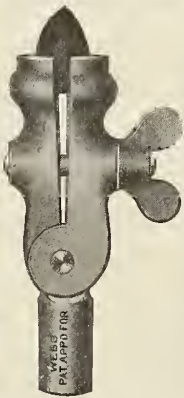

"BUILT CORRECTLY"

Highest conductivity and perfect contact. All working parts

AWAY FROM THE INTENSE HEAT OF THE ARC

Steel studs and wing nut cannot bind. Operators using them claim to get a Brighter Light.

PRICE \$1.00, Postpaid

Give size of carbons used when ordering.

**Motion Picture Specialty
& Repair Co.**

326 3rd Ave. Pittsburg, Pa.

PROJECTION

(Continued from page 136)

positive (upper), and $\frac{3}{4}$ -inch lower, set with the positive a little in advance of the negative, have been found to give good results.

Simple Eye Protection Device

For protection to the eyes a simple device, made of thin iron, is placed or hung so as to obstruct the rays reflected back from the cooling plate. The metal is bent at a right angle, forming a shield to the light at the top and side toward the operator. When it is necessary to inspect the arc, or position of the light cone on the cooling plate, further protection to the eyes is had by wearing spectacles with smoked or black glass lenses. These glasses are also used when removing any accumulation of dust, film particles or obstructions held in the picture opening.

A very ingenious device is used here for removing these obstructions. A glass medicine dropper with a bent nozzle having a rubber tube attached about 8 inches long, and a rubber bulb of good size at the other end of this tube, forms a very efficient blower for this work. It has also the great advantage of not showing in the picture while being used.

There is a switchboard enclosed panel with the necessary knife blade switches, link fuses, meters and indicating ground lights. The lamp houses are insulated from the balance of the iron work of the projectors and a ground wire is attached separately to the lamp houses to the indicating lights on the switchboard. Any grounding of the wiring to or within the lamp houses are immediately shown by one of these lamps burning brightly.

Optical System in Use

The optical system used on these projectors consists of the standard $4\frac{1}{2}$ -inch diameter plano-convex condenser lenses, each of $7\frac{1}{2}$ -inch focus, mounted with the curved surfaces towards each other in the condenser cells. The objective lens is an 8-inch focus Gundlach (No. 2), mounted with a rack and pinion adjusting screw. The lenses are cleaned twice a day.

The film rewinding device is motor-driven. A measuring attachment, a film patching device and a piece of plate glass inlaid in the table top with a lamp bulb underneath, are all aids in quickly putting films in order to again project in the machines. A Mortimer film cleanser is used often to keep the films in condition.

Any minor defects seen on the screen or any unusual noise in passing through the projectors are recorded and examined upon rewinding. Interruption from film breakage is unknown in this house, from the constant watching of the condition of the films.

Saturday mornings are used for rehearsals for the next week's performance of film subjects and appropriate music. Close attention is paid to these two things. Any special films submitted to be shown in this house can be projected on a smaller scale in the office of the managing director, where a projecting outfit is installed for this use.

A good projecting machine, a capable operator, motor drive for the projector and automatic feeding of the carbons, then a good screen are essentials in obtaining GOOD PROJECTION.

Automatic Electric Economizer Means Better Pictures

A DEMONSTRATION was recently given of the a. c. to d. c. economizer and excellent results were shown. This outfit consists of an induction motor of about 5 h. p. directly connected to a specially wound d. c. generator of about 4 k. w. capacity. Both are rigidly mounted on an iron base frame. The flexible coupling may be used also as a pulley drive to the generator in case of a shutdown to the outside service, provided, of course, a small gas engine is installed for these emergencies.

The field windings are so constructed that when one arc only is to be used at a time no resistor is necessary to regulate the current strength. The arc is transferred from one machine to the other without any touching of the generator or switches.

The act of striking a new arc in the machine coming on, extinguishes the arc in the machine left burning. A dissolving effect of the two pictures is thus produced on the screen. Should the two carbons become "frozen" or held together, there is no overload to the generator and no danger of burning out the armature.

By means of a double throw switch, mounted conveniently for

Be sure to mention "ACCESSORY NEWS" when writing to advertisers.

Novelty Slides

Just off the Press

1915 Catalog

of

STOCK ANNOUNCEMENT SLIDES

Largest line of

ADVERTISING PHOTO-PLAYER FEATURE ADVANCE WAR NEWS AND SONG

SLIDES

Novelty Slide Co.

67 West 23d St., New York

SAVE 35%

on your

CARBONS

Burn your studs with a

CARBON Economizer



Pat. applied for.

Fits any lamp, gives perfect contact and conductivity made of special material, screw does not come in contact with carbon and will not weld to body of economizer; will burn upper or lower carbon to $\frac{3}{4}$ of an inch.

OVER 1500 IN USE
"MECHANICALLY CORRECT"!!

Guaranteed to give satisfaction

\$1.25 Each. Sizes $\frac{1}{2}$ "- $\frac{5}{8}$ "- $\frac{3}{4}$ " \$2.00 Set—any sizes.

Sent postpaid upon receipt of New York Draft, Money Order or Cash.

THE CARBON ECONOMIZER CO.

757 W. Onondaga St. Syracuse, N. Y.

the operator, two arcs can be arranged to burn at the same time from this same generator.

The induction motor can be had for all frequencies, single, two-phase, three-phase and all voltages from 110 up to 600 volts circuits. Polyphase, low frequency and high voltage circuits are to be preferred for the advantage of lower first cost and a possible smaller sized motor.

Loss of Power Not Forty Per Cent

The efficiency of the outfit is claimed at 60 per cent. and this is a fair supposition. But the loss of power is not 40 per cent., as this statement shows. The true basis of comparisons shows a gain above 40 per cent., as can be shown in the following computation. When the a. c. power is used directly for the arc light a suitable resistance is necessary to regulate the strength of current to about 40 amperes. The line voltage being 110, the meter will register 110 x 40, or 4.4 k. w.

When an economizer of this type is installed the current being d. c., only about 25 amperes are necessary to obtain an equal, or better, light. No fixed resistor is now necessary and the loss in heat from the resistance wire is saved. The power now used in the arc light is 25 x 60, or 1.5 k. w.

Adding to this the lost power in the efficiency of this outfit, namely, 1.5 divided by 60, gives 2.5 k. w. as expended within the induction motor to drive the d. c. generator, the meter will now only register this smaller consumption of power, which is exactly 57 per cent., or say, one-half (43 per cent. exactly) of your monthly power bill which is saved by installing this type of an economizer.

Motor-generator outfits are not considered very efficient power transformers as the claim of 60 per cent. shows that nearly one-half of the power is lost. But when it is used with a particular form of field winding and the resistor can be omitted, then there is a saving in power that would otherwise be wasted in the heat from the resistor.

Still further gain is then had by the change to direct current, which gives a better light with less strength of current. And still further, a quiet arc light is obtained.

Improved Appearance of Pictures

The operator will be more at ease from working in an operating room comparatively quiet; a better quality of light is also projected with improved appearance of the pictures, and the operating room temperature is cooler from the lack of radiating heat in a resistor.

Exhibitors will aid their operators in giving good projection by investigating this matter and having this figuring of the saving to be obtained verified. Then invest in a a. c. to d. c. economizer of the type shown in the picture. The high first cost of the outfit will be saved in only a few months' time. The days of static economizers are numbered, except for emergency use.

Low Price Motor for Either A. C. or D. C.

A SPECIAL motor has been put on the market for operating motion picture machines which is of very moderate price and can be mounted by the operator in a few minutes. The motor is made for either alternating or direct current, whichever is accessible, and is provided with a speed controlling lever giving a wide speed range, and is furnished with a grooved pulley for a round belt. The motor is intended to attach to the ordinary lamp socket or receptacle and is manufactured by the Fidelity Electric Company, of Lancaster, Pa., the manufacturers of the well-known Fidelity line of electric fans.

SLIDES
OF ALL DESCRIPTIONS
Excelsior Illustrating Co.
219 6th Avenue, New York City
Tel. 7760-7761 Chelsea

PLAYER SLIDES
Just what you need, the best made, \$1.75 per dozen. Say Who. There is only one place to get them and that's from the NIAGARA SLIDE CO., Lockport, N. Y.

**TODAY
COMING
TOMORROW
MONDAY
TUESDAY
WEDNESDAY
THURSDAY
FRIDAY
SATURDAY
SUNDAY**

Made of enameled metal with a bright red background, white embossed letters and eyeholes in the corners. Measures 28" long by 4" high.

Mr. Exhibitor:

All the Wise exhibitors are ordering this new novelty in announcement signs. Are you one of them? They are the best durable, and most economical sign now on the market.

If your local exchange does not handle "SCHILLER'S METAL SIGNS," write direct to us enclosing money order for \$1.50, when we will forward your order the same day it is received.

These signs can be secured from the General Film Company's Branches.

SCHILLER FILM COMPANY
Schiller Bldg. CHICAGO, ILL.

We Can Equip Your Theatre Complete

We are Distributors for the Powers, Edison, Motiograph and Simplex Machines, and Genuine parts, also Poster Frames, Indirect and Semi-Indirect Lighting Fixtures, Tickets, Screens, etc.

We sell for cash or on the easy payment plan. Write today for our new catalog just off the press.

AMUSEMENT SUPPLY CO.
160 No. Fifth Avenue Chicago, Illinois



The "FULCO" Book No. 5

NOW READY—ASK FOR IT

FITS YOUR POCKET Most complete Catalog in existence of Machines and Supplies involved in the presentation of

MOVING PICTURES
E. E. FULTON CO.
156 W. Lake St. CHICAGO

Sole Agents for the Wonderful "GUIL PASTIL" (for Gas Users).

CRYSTAL-LIGHT SCREEN

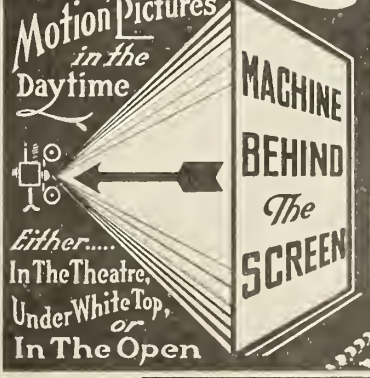

Seamless All sizes. Mounted on roller. Can be rolled and unrolled indefinitely. Flexible. Will not crack. This screen is non-reflective, free from eye strain and translucent. Depth of perspective WONDERFUL.

If you have the room, by all means put your booth behind the screen and enjoy the advantages of a CRYSTAL-LIGHT screen and rear projection; the results will astonish you, and will improve your business tremendously.

CRYSTAL-LIGHT SCREEN CO.
411 West Depot St., Knoxville, Tenn.

for REAR PROJECTION

Building and Furnishings

Flowers as a Basis of Prosperity

HOW many exhibitors realize that details in decoration count? A man pays big money to an architect for plans. The house is finished and architecturally it is perfect, but very often there is that something which is lacking which draws the crowd. The general finish may be cold; there is not that about its "atmosphere" which gives it warmth. In other words, "it does not get across."

One of the methods employed by many progressive theatre owners to overcome this condition is the use of floral decorations. There is not a nature which is not appealed to by *flowers* and plant life in general. There is that something about it which attracts.

The redecoration of the Melba Theatre of Detroit tells the story. This house, although one of the best appointed in the city, recently called into consultation the Schroeder Art Flower Manufacturing Company to see what could be done.

A handbill has been sent out broadcast, together with local newspaper announcements and other means of publicity.

Artistic Decorations Necessary

The result on the public is not surprising and has only gone to show that artistic decorations which lend warmth and atmosphere help materially.

The house is now decorated with a special designed garland, the foliage in a light green to harmonize with the wall color. These garlands are draped from the wall to the house chandeliers, being studded with a light shade of pink Clematis flower.

On the walls are a series of baskets which cut the bareness for the wall. To these are attached large branches of foliage to make the baskets appear more massive.

At the front and around the screen are twenty palm trees forming a half circle so as to hide the orchestra and the sides of the screen. Around the entire screen are massed flowers and foliage, doing away with the old idea of the simple frame that is used in most picture theatres.

A window box filled with flowers and vines extends around the entire lobby. In the box office there is a large plant with electric roses which attracts from the outside.

The decorating of this house was so inexpensive and the results, as a patron drawer, so pleasing that a contract has been signed whereby it is to be redecorated every three months.

The method employed by the Schroeder company in filling orders out of their immediate vicinity is to have the theatre owner send photographs and detailed description of the interior of the house, from which the company draws up designs in color which are submitted.

Fireproof Material Used

All the materials used by the floral decorating companies are well fireproofed so that they conform in every way to the strictest fire regulations and can be installed without fear.

At the present time Mr. Schroeder is making a special play on a novelty for the ticket booth in the form of a holly wreath with its red berries and ornamented with red Poinsettia flowers. This is studded with miniature electric light bulbs giving a very striking effect, which will immediately attract the attention of passers-by. This may be attached to any electric light plug.

There are other companies scattered about the country in various places who are carrying on this same line of decorating work, of whom Frank Netschert and the General Flower Decorating Company of New York are two.

St. Louis Theatre Has Woman Operator

MRS. L. B. STODDARD, manager of the Monroe Theatre at 2816 Chippewa street, St. Louis, is one of the few women moving picture operators in the country. She manages her show and operated her own projecting machine for seven months recently, and says she would be a full-fledged member of the Operators' Union if they would admit her to membership.

Work Commenced on Fillmore Street House, San Francisco

CONTRACTS have been awarded for the erection of a one-story and basement class "A" theatre building at the northwest corner of Eddy and Fillmore street, San Francisco. The building will cover an area of 41½ feet by 137½ feet with an addition for store purposes covering almost twice this area.

The theatre will cost in the neighborhood of \$50,000 and will be one of the finest in the outlying districts of the city. It is being erected by J. R. Hanify for the Kahn & Greenfield Circuit and is to be made ready for occupancy at the earliest possible date.

Splendid weather for building has been experienced so far and in case the winter rains are not too severe it is believed that the structure will be ready late in March.

Joe Langley, for some time manager of the Richmond theatre, conducted at Richmond, Cal., by Turner & Dahnken, has been made manager of the New Alameda theatre, Alameda, and Mr. DeLorme, of the latter house, has been transferred to Richmond.

Two Theatres Added to Michigan Contingent

THE Princess Theatre, Cadillac, Mich., was formally opened December 2 for the first time. The new amusement place is modern in every respect. The outside is finished in white; the inside decorations are neat, although not elaborate. The house seats 350 people. The system of lighting is indirect.

Harry Mertz, who with his father and brother owns the property and building, will be the manager, and Alfred Schoenhoals, the operator. General admission will be five cents, except on Wednesdays, Saturdays and holidays, when special features will be shown and the price increased to ten cents.

The Aladdin Theatre in Bay City, Mich., opened November 30. It was scheduled to open the afternoon of the day previous, but a delay was caused by the motion picture machine which was slightly damaged in transit. The opening attraction was Ethel Barrymore in "The Nightingale." The opening was an auspicious one; long before the house opened, the entrance and curb were lined with people.

New Michigan City Law for Projection Machines

AN ordinance has been prepared and will be introduced in Pontiac, Mich., that provides for the materials and method of construction of buildings in which motion picture machines may be used and provides for their regulation, installation and operation.

It provides that in any building, the walls and floors of which are brick, concrete or reinforced concrete, located 75 feet from any other building, moving picture machines may be installed, but that a written application to the commissioners for a permit must first be made.

This is to get around the state law which provides that no moving picture show can be given above the first floor of any building.

Site for \$150,000 Jersey City Theatre Purchased

MESSRS. Hall and Smith, owners of the United States Garden Theatre, of Elizabeth, N. J., and of the United States Theatre, Hoboken, N. J., have announced the purchase of a site for a new motion picture theatre in Jersey City. Manager Smith, of the Elizabeth playhouse, said the Jersey City house would be built on Bergen square in the most exclusive residential section of the city. The new theatre will cost \$150,000 and work of construction will be commenced in the early spring.

ELECTRICAL CHRISTMAS WREATH

A WREATH THAT GIVES THE REAL CHRISTMAS CHEER

A Theatre Decoration That Attracts the Eye



Made of green FIREPROOFED material, leaves and berries ornamented with bright red POINSETTIAS, studded with 8 miniature electric lights, all ready to attach, 18-inch diameter.

Manufactured by

THE SCHROEDER ART FLOWER CO.

6023 SUPERIOR AVE., CLEVELAND, O.

FURNITURE & FURNISHINGS

On RENTAL

We equip your settings complete in accordance with your scenario.

WILLIAM BIRNS

103-105 West 37th St.

Phone: Greeley 6255.

ROLL TICKETS

Specially Printed and Absolutely Guaranteed

Cash with order. No C.O.D. at these prices.

50,000 for \$5.40 200,000 for \$15.30

30,000 for 4.50 100,000 for 9.00

Write for Samples and Prices on Other Quantities.

Rees Ticket Co., 400 So. 10th St., Omaha, Neb.

MOVING PICTURE THEATRE MAILING LISTS FOR SALE

20,192, covering United States and Canada, Price \$40.00, or \$3.50 per thousand for such states as you want.

- 795 Film Exchanges, U. S.\$3.50
- 70 Manufacturers and Studios, U. S..... 1.00
- 34 Moving Picture Machine Mfrs. and Dealers..... 1.00
- 231 Film Exchanges, Foreign Countries..... 3.00
- 520 Moving Picture Theatres, Foreign Countries.... 3.00

Ask us for full particulars.

TRADE CIRCULAR ADDRESSING CO.

166 West Adams Street, Chicago
Established 1880

MENGER & RING

302
W. 42nd
Street
New York

TELEPHONE
BRYANT 6621

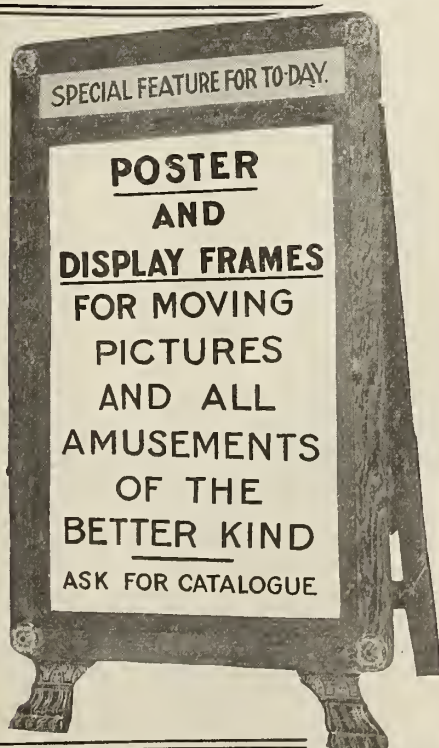

Make Your Lobby Display Attractive

There is nothing more fascinating to the public than a bright brass frame to display your photos or posters.

We make Lobby and Theatre Fixtures and Brass Rails of every description.

Don't fail to visit our Showrooms. Write for catalog.

THE NEWMAN MFG. CO.

717 Sycamore St., Cincinnati, Ohio
Branch Factories and Show Rooms:
101 Fourth Ave., New York, N. Y.
106-108 W. Lake St., Chicago, Ill.
Established 1882.



Directory of New Theatres

EDITOR'S NOTE.—The information contained in the "Directory of New Theatres" is gathered by the field representatives of "Motion Picture News" and the facts and figures in each instance have been verified by them and are authentic. They may be relied upon by members of the trade.

Theatres Here and There

PLANS are made for a new theatre at Delmar, near Hamilton avenue, St. Louis, that will seat 1,500 persons. The new house is to occupy part of the ground floor of a building that is to be erected on the corner in question, and will be first-class and up-to-date in every particular.

The Mutascope Theatre, operated by Pohlman and Zimmerman, on the ground floor of the building at 3200 Olive street, St. Louis, has been closed as a result of the building being torn down. Pohlman and Zimmerman also own and operate the Comet Theatre at 2112 Market street.

The World's Dream Theatre at 1413 Market street, St. Louis, has reopened after extensive alterations with a new name and a new manager. The name of the house is now the Amuse U, and its destinies are looked after by John Francis, an experienced picture show manager who comes here from Decatur, Ill.

Three St. Louis Theatres Change Hands

Scherer Brothers, who have operated the Palace Theatre at 1310 Franklin avenue, St. Louis, for the last five years, have acquired the Mikado at 5900 Easton avenue. The Mikado is one of the large O. T. Crawford houses, built three years ago, and operated as a mixed picture and vaudeville house. Scherer Brothers will use an all-picture program and feature Paramount releases.

G. Chiaple has bought the Coliseum Theatre at 1219 South Broadway from its former owner, Alex Papadricos. Mr. Chiaple will continue to use the same program, four reels of Mutual pictures for five cents.

John Kuppertz has assumed control of the Eclipse Garden at 428 Primm street, and has installed a new Edison projecting machine in the theatre.

The Kings Theatre at 800 North Kingshighway, St. Louis, is now under the management of M. J. Cunningham, a well-known theatrical exchange man, who is conducting the house and doing excellent business with a mixed picture and vaudeville bill.

Chas. J. Vollmer, manager of the Strand Theatre, which opened two weeks ago at Sixth and St. Charles streets, St. Louis, is also owner of the Bernays Theatre, at Bernays and Harney avenues, and is planning a big airdome for North St. Louis, to be opened early next summer.

Theatres in the Mississippi Valley

The Grand Opera House at Mount Olive, Ill., has been equipped for a moving picture theatre. The place will be called the Gem, and will be operated by W. H. Klein and Oliver Weidler.

The Grand Theatre at Litchfield, Ill., has a contest with a \$50 prize for the boy or girl selling the most tickets to the Grand. The mother of the winner will get a thirty-day pass to the theatre.

The Olympia Theatre at Kewanee, Ill., has changed hands and will be operated only three days a week, Friday, Saturday and Sunday. C. M. Merritt is the new owner, but John Schienberger will manage the place, as usual.

A four-hundred seat moving picture theatre will be opened by Diamond and Decker in Havana, Ill., early in December.

Watson and Wright, exhibitors of Bevier, Mo., are refurbishing their theatre.

E. E. Wagner, who manages the Bijou Theatre at Lamar, Mo., has increased the seating capacity of his house and put in 275 more opera chairs.

F. K. Snyder, of St. James, Mo., is advertising his 300-seat theatre for sale.

C. B. Patterson, manager of the Best Theatre in Pulaski, Tenn., has recently increased the seating capacity of his theatre.

Thomas O'Dowd has opened a new theatre at Hillsboro, Ill., in addition to one he already has at Witt, Ill.

Among the Theatres of California

The Imperial Theatre, Eureka, Cal., until recently conducted by Pettingill & Pettingill, has been taken over by P. Roswald, of San Francisco, and a number of important changes are being made in the house. A costly heating and ventilating system is to be installed, a fine Wurlitzer player has been purchased and new equipment has been placed in the operating room.

The Strand Theatre, one of the finest houses erected on the East Bay side to be devoted exclusively to motion pictures, was opened on the afternoon of November 26, under most auspicious circumstances. This new house is located on College avenue, near Ashby avenue, Berkeley, Cal., in the center of an exclusive residence district, with a large territory from which to draw. It is owned and conducted by Messrs. Beach & Krahn, who conduct the Lorin Photoplay Theatre in South Berkeley with so much success. Mr. H. L. Beach is president of the Motion Picture Exhibitors' League of California, and Mr. Krahn is also a well-known exhibitor.

Officials of the Turner & Dahnken circuit have just been advised that the plans for adding to the working capital of the concern have been successful and that the Turner & Dahnken Controlling Company, of San Francisco, has been formed at London.

The capital stock is now placed at \$2,500,000 and the announcement is made that \$1,000,000 of this has just been underwritten by London capitalists. This concern has been planning for some time to still further extend its circuit and will probably enter the southern California field, this matter having been under consideration for some time. General Manager C. L. Langley has made several trips of late to Los Angeles and other members of the company have been looking over the field there.

F. Fink is planning to erect a moving picture theatre at Gridley, Cal.

F. Tessier has opened the Isis Theatre, Truckee, Cal., for the winter season. It is expected that many visitors from the outside world will visit Truckee this winter to enjoy the ice sports.

The Dorris Theatre at Roseville, Cal., has proved to be too small and will be enlarged at an early date.

The Fair Theatre, Fresno, Cal., has just installed new projection equipment secured from the Golden Gate Film Exchange of San Francisco.

The Melrose Theatre, Oakland, Cal., is to be remodeled and will be reopened shortly under new management.

A. W. Black and M. V. Rickle, formerly of Saginaw, Mich., have purchased the Family Theatre, Owosso, Mich., from Mat Mauer and Harry Monroe. Mr. Mauer will engage in the purchase and rental of moving picture films, with headquarters in Detroit, his former home.

Messrs. Black and Rickle will immediately make improvements, such as the installation of a new screen and operating machine. The policy of the theatre will be Paramount pictures four nights a week, with a combination of vaudeville and pictures the remaining three nights.

\$35,000 Theatre Opens in Pennsylvania

One of the handsomest houses in Washington County is that of the Star Theatre at Canonsburg, Pa. It was opened recently and is sure to be the most popular theatre in that town. The class of performers that are being shown and the attention of the attaches to the slightest detail as to the comfort of the patrons makes it possible to work wonders in that town.

The seating capacity of the house has been increased to 450 and the exceptionally high ceilings make the theatre the best ventilated

LOBBY PHOTOGRAPHS

ANY SIZE
ANY FINISH

Made from original negatives posed especially for us by leading

PHOTOPLAYERS

Either straight or character.
Prices on Application.

Photoplayers Studio

Phone A4399
342 SO. BROADWAY,
LOS ANGELES

REDUCE YOUR EXPENSES
Use Corcoran Tank System
Get Price List No. 6
A. J. CORCORAN, Inc.
9½ John Street New York

HARRY K. LUCAS

"The Supply King"
ATLANTA, GEORGIA

Everything for the theatre, even the film. Catalogue for the asking. Write today.

Manufacturer of the
FAMOUS HAKILU PRODUCTS
Oil, cement, silver finish, gear compound, etc.
Wholesale and Retail.
DEALERS: Ask for Samples.

in that part of the State. The house and its equipment cost \$35,000 and it was built by A. M. Forsythe, who has been in the merchant tailoring business in that section for the past forty years. His son, Earl M. Forsythe, a newspaperman and advertising expert, is the manager of the house and is watching the slightest details.

The interior decorations are of the finest and the outside of the house has also been made most attractive. The Universal Service is used exclusively and the equipment is of the latest type in every particular.

Another new theatre is to be erected in East Liberty, one of Pittsburgh's suburbs. Work has been started on the new house of C. J. Keller, one of Pittsburgh's oldest hotel men. The house is to be built at the corner of Lemington and Lincoln avenues and will be 30 by 120 feet and will have a seating capacity of 300. It will be built according to the new building code as laid down by the State legislature at Harrisburg, Pa.

The Strand Theatre at Morgantown, W. Va., will hereafter show the Paramount features.

New Theatre Opens in Knoxville

The Crystal Theatre, the newest motion picture theatre in Knoxville, Tenn., at 425 Gay street, was opened November 27. The new movie theatre has a seating capacity of 400, including 100 seats in the balcony. A diversified program, including new features, comedies and dramas, will be shown in catering especially to the ladies and children.

The Queen Theatre, Greenville, Ky., opened November 26 under the management of Roy Wells.

The Rex Theatre, Lancaster, Ky., gave its opening show Thanksgiving evening. The Rex is one of the most substantially constructed motion picture theatre buildings in Kentucky, being 80 by 100 feet, three stories in height and built entirely of concrete blocks. The lower floor is equipped as a garage and contains a modern lighting plant to light the entire structure.

The theatre is located on the second floor, while the third floor will be used as a lecture hall and for lodge purposes. The theatre floor has a seating capacity of 400 and suspended balcony seats for an additional 100. Exits and fire escapes are conveniently arranged and a complete and thorough system of ventilation is in effect throughout the building. H. Israel is manager of the new theatre.

Duchess, a Converted Church, Opens in St. Louis

THE Duchess Theatre, at Grand and Washington avenues, St. Louis, opened Saturday, November 28. The Duchess was formerly a Presbyterian church, but the architects in charge of the alterations planned two rooms on either side of the steps that lead into the building, that can be used as shops or offices, and serves to rob the structure of its churchy appearance. The interior of the building adapted itself very readily to the needs of a theatre.

The auditorium, which has been fitted with 800 seats, is very roomy, with generous spaces and aisles, and the high ceiling, with its beautifully finished woodwork, adds much to the beauty of the place. The large stained glass windows of the church will not be disturbed.

W. W. Busby is the owner of the new theatre, and C. H. Tabler, who is a son of Frank Tabler, manager of the General Film Company's local office, is the manager. The performance will be continuous from 12 noon to 11 at night. Ten cents admission will be charged and five reels of pictures shown.

PENNANTS

PILLOWS

FELT AND LEATHER NOVELTIES FOR

Premiums and Advertising

INCREASE YOUR BUSINESS—LET US FURNISH YOU SPECIAL ATTRACTIVE PREMIUMS WHICH WILL DRAW THE CROWDS. We make a specialty of premiums for advertising purposes.

We can furnish attractive and inexpensive novelties of all kinds which will more than double your attendance whenever used. Try it! You will be more than pleased with results obtained.

Write us for full particulars, prices, etc.

PACIFIC PENNANT & NOVELTY CO.

246 No. New High Street
LOS ANGELES, CAL

LANG'S FILM REELS

THE BEST MADE

14 in. \$1.50 12 in. \$1.25 10 in. \$1.00

CATALOGUE

LANG MFG. WORKS, Olean, N. Y.

HERE IT IS



← SPEED LEVER

MOTORS FOR MOVING PICTURE MACHINES
110-60 Alternating Current \$14.00
110 Volts Direct Current \$12.00
Furnished complete with speed lever giving a speed range of 50%. Immediate delivery for cash with order.
Fidelity Electric Co., Lancaster, Pa.
WE MAKE MOTOR-GENERATOR SETS

MOTION PICTURE PRODUCERS

Let our Felt Banner help your production move



This Banner helped make the Balboa Feature Film Co. famous



Send for Price List



PHOTOPLAYERS

Your picture reproduced on our pennant will bring you closer to the people

Music and the Picture

Editor's Note.—This department is prepared to answer all questions from exhibitors relating to the use of music in connection with photoplays, and to suggest suitable music for current pictures. Correspondence will be welcomed

One-Man-Orchestras Run Gamut of Musical Effects

By H. S. FULD

HIGHER prices, better films, larger and more pretentious theatres, and with the advent of the feature films more appropriate music is the trend of today.

There was a time when exhibitors believed that pictures alone constituted the show, and that as long as there was a piano, or piano and drum banging away, it was sufficient for the musical accompaniment to the pictures.

This was the era of the converted store theatre, but with the coming of the feature film things started for general betterment. Theatres that formerly seated up to three hundred were quickly altered to enlarge their capacity and in some cases trebled it. New theatres seating from nine hundred to three thousand were rushed to completion.

But with better theatres, better films, better projection and better everything except music, the public became critical, and the cry on every hand was "Why not better music?"

Manufacturers of musical instruments were quick to see their opportunity and immediately centered their attention on the making of instruments especially intended for the motion picture theatres, with the result that a number of so-called one-man-orchestras was soon on the market.

These instruments are a combination of piano and organ, with chimes, xylophone, drums and drummers' traps, sound effects for use with the pictures all combined in the one instrument and operated from a keyboard; played the same as one would play a piano or organ. Most of them have the additional advantage of being capable of rendering the musical and trap accompaniment automatically, with the aid of specially punched music rolls, or as is the case of one of them, a regular or ordinary roll such as is used in any automatic piano-player.

Different Size Orchestras

These one-man-orchestras differ in size and general arrangement, but taken collectively, every instrument used in band or orchestra has been successfully imitated by an equivalent pipe-stop or percussion effect; also many old-time and ancient instruments now obsolete have been resuscitated and put in use in these machines.

An additional advantage credited to these instruments is, that some tones that are not possible to render with an orchestra or band instrument, such as Vox Humana and so on, are possible with these.

With violin, cello, clarinet, horn, cornet, flute, harp, chimes, xylophone, piano, either singly, in group or all together, all manner of sound effects, drummer's traps and so on are possible of accompaniment with the pictures.

Among the sound effects capable of being produced with one of these instruments are wind, rain, railroad train or whistle, steamboat whistle, automobile or motor boat engine, auto-horn, locomotive bell, tambourine, castanets, tom-tom, horses' hoofs, crash, cymbals, base and snare drums, triangle, cat, dog, chicken calls, lion roar, baby cry, and so on indefinitely. Almost any sound effect that could possibly be called for by the action on the screen is possible with one of these machines.

The instrument is played from the keyboard as previously mentioned and the traps by pushing a button, pressing a pedal, or pulling a cord, as the case may be. Any instrument, whether it be violin, horn, flute, etc., may be played solo with or without piano or all may be used in any combination desired by the operator. The pipe-organ being the basis of this one-man-orchestra, a se-

lection by a competent performer is a welcome addition to any program and enthusiastically received by any audience.

These instruments are in some cases equipped with a solo self-playing attachment, a separate solo manual or keyboard placed a little above the main keyboard, or both an upper and lower manual and automatic.

Probably the best known manufacturers of these one-man-orchestras are the Rudolph Wurlitzer Company, American Foto-Player Company, J. C. Seeburg Piano Company, Bartola Musical Instrument Company and the Marquette Piano Company.

While it is not logical to suppose that these instruments will immediately replace pianos and untrained orchestras in all the theatres, nevertheless they are rapidly being installed by the exhibitor who can see the "hand writing on the wall." There is still a number of theatres whose proprietors are having but indifferent success with their present musical equipment, and they would do well to install one of these instruments as soon as possible.

When one stops to think just what can be accomplished in the way of accompanying the pictures with one of these machines, it is not to be wondered at that these one-man-orchestras should take the place of the piano and drum and other orchestras. Any person who can play a piano or organ can operate one of these instruments, can follow the plot or story of the film, with appropriate music and sound effects, and, most important of all to some exhibitors, the instrument can be paid for in a year or two by the saving on the salary list.

Orchestras Capable of All Effects

It has been proved that these instruments embody every orchestral effect, and by improvisation the performer or operator can closely follow the story as it appears on the screen, adjust the music to suit the action, jump on the instant from comedy to tragedy music, and also have at his immediate hand any and all traps and sound effects necessary to make the picture more realistic. And all this is under the control of one performer and one mind.

There is only one way to play music for the accompaniment of the pictures and that is the right way. As has been advocated in these columns over and over again, "FIT THE MUSIC TO EACH SCENE" and don't play any long selection that will run through numerous scenes without any possibility of being in any way appropriate.

The advantages of the one-man-orchestras stand out prominently. They combine all the advantages of a full orchestra, and what is more important, none of the disadvantages. They also have the additional merit of being operated by one person.

The operator can change his tune or selection; he can change and select any combination of instruments; he can on the instant change from horn to violin, or flute to full orchestra, and jump to cello solo or make any other combination which may occur to him. All this is possible without any stopping or hesitating or any apparent break in the music, and to cap it all, at supper hour the machine can run itself—"just start the roll."

It might not be a bad idea for the managers and proprietors of these theatres who are desirous of improving the musical equipment of their respective theatres to write or get into communication with the musical department of MOTION PICTURE NEWS.

New Organ for Garden, Detroit

A BEAUTIFUL new pipe organ is being installed in the Garden theatre, Detroit, Mich., owned by John H. Kunsky. It will have 20 stops, including a set of cathedral chimes and other novel features.

You Need What You Need When You Need It You Need The Mirroroide Screen NOW

Whether you are just starting in, or have been in business, the fact remains you need a Mirroroide Screen.

Anything that will make it possible for you to increase your business, and hold it after you get it, is absolutely necessary for you.

The old days of the muslin sheet, a few chairs and the dingy piano are gone. The modern theatre representing thousands of dollars is the result of competition, and the live wire exhibitor is the one who succeeds.

Now isn't the fact that your pictures, which are the goods you are selling, will be clearer, brighter, at less cost for current, a sufficient argument for you to consider Mirroroide and consider NOW?

Send for large free samples, use your eyes, and be convinced.

3 TINTS
SILVER WHITE
SILVER FLESH
PALE GOLD
36½ cents per square foot

MADE IN AMERICA BY
THE J. H. GENTER CO., INC., NEWBURGH, N. Y.
BUT USED THROUGHOUT THE WORLD

2 FINISHES
GRADE A }
Smooth } MATTE
GRADE B }
Rough }

LOOK!



LOOK!

It defies the sun and will pay for itself in one day!

Used by
New York M. P. Co.
Vitagraph Co., Santa
Monica, Cal.

Golway Feature Film
Co., San Gabriel, Cal.
Liberty Film Co.,
San Mateo, Cal.

Keystone, Bosworth, Statle
Club, Los Angeles, Cal.
Universal, Sterling, Holly-
wood, Cal.

May be used without altera-
tions for either direct or
alternating currents.

WINFIELD-KERNER COMPANY, Mfrs.
Record Bldg., 612 Wall St., Los Angeles, Cal. Phones: Main 8400; 10711

The Leading Film Producers are Using the
WINFIELD-KERNER ACTINIC RAY

MOTION PICTURE LAMP

[Patented]

NO MORE WAITING FOR SUNSHINE — PLAYERS CAN WORK EVERY MINUTE

BRIGHT AS CALIFORNIA SUNSHINE
AND

EVER READY AND ALWAYS RELIABLE

A letter or phone
call will bring full
information.

The Rex Film Renovator

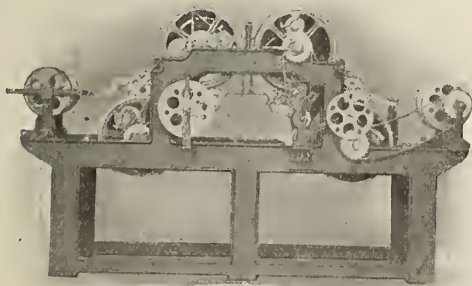

PATENT-PENDING

It is now successfully operating in four of the Mutual Film Com-
pany offices, located at

- No. 97 Woodward Ave., Detroit, Mich.
- No. 422 N. High St., Columbus, Ohio.
- No. 902 Filbert St., Philadelphia, Pa.
- No. 150 N. Illinois St., Indianapolis, Ind.

and twenty-one other leading Universal and Warner and other Feature
Exchanges. If it is good enough for the Mutual it should be good
enough for the Exhibitors to demand a service free from rain and
dirty films.

The Midget Cleaner and Noiseless Rewinder is approved by many
Exhibitors. Eventually it will be a machine for the operating booth
and small Exchanges. Everybody get wise.

Write for booklet "Creating Good Will," which also has the best
Cement Formula. It's free.

The Rex Film Renovator Mfg. Co.

272 N. Third Street Columbus, Ohio

WE RENOVATE FILM. WRITE FOR PRICES.

ACCESSORY AID

We stand always ready and
willing to help all our read-
ers in making their pur-
chases. We buy nothing
but we will tell you where
your needs can be supplied

to

YOUR BEST ADVANTAGE

Without obligation on my part please tell me where I may purchase
the following:

.....
Name

.....
Theatre

.....
Address

SHARLOW BROS. CO.

440-442 West 42nd Street
439-441 West 41st Street
NEW YORK CITY

MANUFACTURERS

of

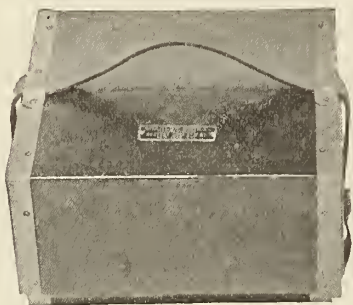

Approved Fibre Lined Telescope Cover Metal Shipping Cases

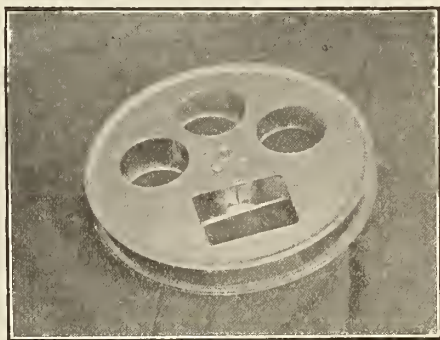

Sharlow's Wood Hub Polished Steel Reels

Made in sizes from 10-12 inches

Film Cans—Film Cabinets

Metal Tables, Racks and Shelves For Exchanges

All Metal Slide Carriers

SEND FOR INFORMATION

Old Films Made New By a Special Process

(Continued from page 135.)

One of the most up to date agencies for doing this work is the Rex Film Renovating Process, which has resulted from many years of painstaking research and experimentation in renovating films. In its first form it was developed by the French Film Restoring Company as a process of cleaning films by hand. This company operated several successful film exchanges, which were finally merged with the Mutual Film Company.

Successful Renovation of Films

The early experience of this company in restoring films revealed a great demand for that sort of service. Films were sent in from all parts of the country to be renovated. The success of the process and the demand for the work led to the undertaking to construct a machine which would do the work more cheaply than it could be done by hand. The result showed that the machine not only did the work more cheaply, but that it accomplished more uniform and better results than hand labor.

The first model of the machine was placed in operation in the exchange of the Mutual Film Company, of Columbus, Ohio. This machine gave excellent satisfaction. It has now been replaced with the latest model.

The Rex film renovating machine long ago passed beyond the experimental stage. The machines are now in use in some of the leading exchanges of the country.

This process of restoring films is fully protected by patents allowed and pending in the United States and foreign countries.

Proper renovating postpones indefinitely the coming on of film old age. It is primarily a cleansing process. It is also a process which rejuvenates the films and greatly lessens the rate of deterioration. It is also a process which enables the exchange to supply the exhibitor with a film service which satisfies his patrons. In doing these things it greatly increases the profit of the exchange and the exhibitor.

Everything used by man should be cleaned. This is especially true in the case of things whose serviceability depends on transparency. For example, windows, show cases and lenses must be cleaned frequently to permit the light to pass through them freely. The need for cleansing is still more imperative in the case of the films. The uncleaned film loses rapidly in transparency on account of the accumulation of sweat and dirt.

The problem of cleaning films is not as simple as that of cleaning windows. Yet this delicate and difficult operation can be accomplished very satisfactorily, and in an easy way.

The Rex renovating process removes from the film the sweat and dirt which cause the wavy, blotchy, rain-streaked appearance of a film in bad condition. This process of renovation renders the picture more brilliant and makes its various features more easily distinguished.

Transparency of Film Restored

Proper renovating treatment restores the transparency of the film; it renews the pliability of the celluloid and prevents the breaking which occurs easily at the sprocket holes. It lubricates the film so that it is not so readily worn out by friction.

The gelatin coating of a properly renovated film will not adhere to the tension springs and idlers. The process thus prevents the damage done to the film in the form of scratches caused by such adhering masses of gelatin.

A film which has been properly renovated a few times will be much more acceptable to the exhibitor and his patrons after it has run ninety days than an unrenovated film which has run thirty days. Many films which have been run two hundred days will please the spectators almost as well as new films. The process will improve any film from 50 per cent. to 75 per cent.

The exchange which employs an up to date renovating process such as the Rex will have far fewer "kicking" exhibitors on its list, and will change the demand of the exhibitor from newly released films to freshly renovated films.

This will greatly increase the good will asset of the exchange by making its service more acceptable to its patrons, as well as greatly lessening the rate of decrease in the earning power of films, thus prolonging the period during which the films are productive of profit.

The Rex film renovating process will accomplish the above results at a monthly cost to the exchange of but a few cents per reel.

FOR SALE

New Lincoln Motion Picture Theatre, 5th and Christian Sts., Philadelphia. Just completed. Modern in every detail. Seating capacity nearly 500, with standing room for about 200. Fully equipped. Positively finest moving picture theatre in South Philadelphia. Would rent to responsible party. Henry E. Silk, 1310 S. 4th St., Philadelphia, Pa.

Your negative developed, printed and titled complete
5c delivered 12 hours
per foot within

Titles 6c per foot

GUNBY BROS., Inc.
145 West 45th Street New York City

Make an Art Gallery Out of Your Lobby

Shake hands with yourself, Mr. Exhibitor, that this Ad caught your eye, then listen to this horse sense array of hard facts. The great American public are Hero-worshippers, do you appreciate that? And did you ever stop to think how lucky you are to be in a business where you can coin that Hero-worship into profitable dollars? Shall we speak plainer? All right—Can a laundry send out pictures of anything or anyone connected with their plant that will cause the public to become hero-worshippers? Can the grocery man make hero-worshippers by showing a bag of potatoes in front of his store? Can a Clothier make hero-worshippers because of the brand of clothes he sells? Funny questions, eh? but answer them and see where you get off at.

But Mr. Exhibitor—where the Laundryman, the Grocer and the Clothier can't make Hero-worshippers, your business can and has already established Hero-worship in the breast of every patron who attends your theatre. Have you ever stopped to realize what a tremendous asset this Hero-worship is to your business? Then why not still further boost this great power that lies right in the palm of your hand? Why not make your Lobby an Art Gallery of Movie stars? Why not make your Lobby so interesting, so elaborate and so attractive that your patrons will go out of their way to see the Gallery you have created? To show you what WE think of this Hero-worship we have designed and produced a series of magnificent poster portraits of Universal players as follows:

King Baggot, Mary Fuller, Cleo Madison, Robert Leonard, Ella Hall, Max Asher, Pauline Bush, Grace Cunard, Wm. Clifford, Francis Ford, Victoria Ford, Hobart Henley, Warren Kerrigan, George Larkin, Edward Lyons, Anna Little, Murdock MacQuarrie, Lee Moran, Nat Moore, Edna Maison, Violet Mersreau, Harry C. Myers, Dorothy Phillips, Mary Pickford, Herbert Rawlinson, Ford Sterling, Rosemary Theby, Marie Walcamp, Ben Wilson, Frances M. Nelson, Billie Ritchie, Gertrude Selby—and still more to come. These are single sheet size elaborately done in 6 colors, and are made up either for unframed or framed display. We advise framing by all means.

No business on earth has such a power for Hero-worship advertising and the immense resulting benefits as YOUR OWN BUSINESS. Then USE IT, wire or write your Exchange and ask them to send you samples of ALL the above stars. They will send you samples and prices—and if your own Exchange can't supply you, wire or write the Morgan Lithograph Co. at Cleveland, Ohio, who will give your request immediate attention. We advise and urge that you write your Exchange first, and then if they fail to send you the necessary samples and prices, write to the Morgan Lithograph Co., Cleveland, Ohio.

Paramount Pictures

LOIS WEBER

The Mother

as

The Daughter



PHILLIPS SMALLEY

BOSWORTH

INC

PRESENTS

LOIS WEBER & PHILLIPS SMALLEY

IN

"FALSE COLOURS"

A play of intense dramatic expression built around the life and tragedy of the theatre.

It is notable not only for the ingenuity of the plot but also for its sincere and forceful interpretation of character by a cast of unusual ability.



BOSWORTH



INC

LOS ANGELES

Released December 17th through the Paramount Program



DECEMBER 26, 1914

Motion Picture News

HAS THE QUALITY CIRCULATION OF THE TRADE

PARAMOUNT PICTURES

JESSE L. LASKY

PRESENTS

DUSTIN FARNUM

THE FOREMOST AMERICAN FAVORITE
PLAYING HIS ORIGINAL STELLAR ROLE
IN A PICTURIZATION OF THE
SOUTHERN ROMANTIC DRAMA

**CAMEO
KIRBY**

By BOOTH TARKINGTON & HARRY LEON WILSON
RELEASED DEC 24

By ARRANGEMENT WITH
THE LEBLER CO.

JESSE L. LASKY FEATURE PLAY CO.

220 WEST 48TH STREET NEW YORK CITY

JESSE L. LASKY PRESIDENT
SAMUEL GOLDFISH TREAS. & GENL. MANAGER
CECIL B. DeMILLE DIRECTOR GENERAL

THE MASTER KEY

by JOHN FLEMING WILSON

*A Thrilling Story of
Mystery and Romance!*

THIRTY

REELS

UNIVERSAL

FIFTEEN

MOVING

WEEKS

WITH
ROBERT LEONARD AND ELLA HALL



SPECIAL
UNIVERSAL
EPISODE FEATURES SIX



DANIEL FROHMAN
PRESENTS

MARY PICKFORD

“ AS ”



CINDERELLA

A NOVEL AND
ORIGINAL VERSION
OF THE
CENTURY - OLD
CLASSIC

IN
MOTION
PICTURES.

RELEASED
DECEMBER
28TH.

Produced by the

FAMOUS PLAYERS FILM CO

ADOLPH ZUKOR, President,
DANIEL FROHMAN, Managing Director EDWIN S. PORTER, Technical Director
Executive Offices,
213-229 W. 26TH STREET, NEW YORK.



DYREDA ART FILM CORP.

FRANK L. DYER, President
J. PARKER READ, JR. Vice-Pres.

J. SEARLE DAWLEY, Dir. Gen'l.
H. J. REDFIELD, Secy. and Treas.



RELEASED

DECEMBER 7th

"IN THE NAME OF THE PRINCE OF PEACE"

FOUR ACTS OF
GRIPPING DRAMA AND THRILLING SPECTACLES
PRODUCED UNDER THE DIRECTION OF

J. SEARLE DAWLEY



LAURA



SAWYER

FEATURING

AND ROBERT



BRODERICK

SECURE THIS EXTRAORDINARY FEATURE THROUGH

WORLD FILM CORPORATION

LEWIS J. SELZNICK, Vice-Pres.

and Gen'l Mgr.



"IN THE NAME OF THE PRINCE OF PEACE"



THE EXPLOITS OF ELAINE

THE CLUTCHING HAND

What or who is it?

That's the question that "Craig Kennedy" (played by Arnold Daly) has to solve in this the biggest and best serial yet.



Released two reels every Monday, beginning December 28th

Book it through the nearest exchange of the
ECLECTIC FILM C'O.

PATHE

THE EXPLOITS OF ELAINE



ARNOLD DALY

"Craig Kennedy," the famous scientific detective character created by Arthur Reeve, finds in "THE EXPLOITS OF ELAINE" problems that tax his powers to the utmost.

He fascinates the hundreds of thousands of "Cosmopolitan" Magazine readers. He will fascinate millions of picture lovers.

Book this intensely interesting serial through the nearest branch of

THE ECLECTIC FILM CO.

AN ALL STAR CAST

Headed by the three great players here illustrated gives in this great serial a remarkable interpretation of a remarkable story.

By special arrangement with the great Hearst newspapers the stories of the exploits will appear in the leading newspapers of every city in the land.



PEARL WHITE



SHELDON LEWIS

PATHÉ

THE EXPLOITS OF ELAINE



ARTHUR B. REEVE,
Novelist and Author of
"THE EXPLOITS OF ELAINE."



LEOPOLD WHARTON,
Director.



CHARLES GODDARD,
Playwright and Collaborator in
"THE EXPLOITS OF ELAINE."

Mr. Reeve is the only author who has successfully applied the wonders of modern science to the detection of crime. Aided by the able playwright, Mr. Goddard, he has written in this serial a photoplay which reveals the truly remarkable methods of a truly remarkable detective—a play which will hold in breathless interest all who see it.

Such a story acted by such a stellar cast and directed by one of the famous Wharton brothers will unquestionably be

THE BIGGEST OF MONEY GETTERS

MR. EXHIBITOR

WRITE OR WIRE THE NEAREST ECLECTIC EXCHANGE AT ONCE FOR BOOKINGS.

ECLECTIC FEATURE FILM EXCHANGES FOR YOUR USE.

ATLANTA	61 Walton St.	CINCINNATI	217 E. 5th St.
DALLAS	202 Andrews Bldg.	CLEVELAND	622 Prospect Ave., S. E.
CHICAGO	5 So. Wabash Ave.	PORTLAND	392 Burnside St.
MINNEAPOLIS	109 Kazota Bldg.	PHILADELPHIA	1235 Vine St.
NEW YORK	115 East 23rd St.	NEW ORLEANS	910 Gravier St.
BOSTON	3 Tremont Row	WASHINGTON	7th and E. Sts., N. W.
LOS ANGELES	114 E. 7th St.	KANSAS CITY	928 Main St.
ST. LOUIS	3210 Locust St.	DENVER	16th and Larimer Sts.
SAN FRANCISCO	67 Turk St.	OMAHA	1312 Farnam St.
SYRACUSE	214 E. Fayette St.	SEATTLE	810 Third Ave.
PITTSBURGH	715 Liberty Ave.	SALT LAKE CITY	68 So. Main St.

THE ECLECTIC

110 West Fortieth Street



FILM COMPANY

New York, N. Y.

PATHÉ

MERRY CHRISTMAS!



Fatty and Minnie He-Haw

Monday Dec. 21



The Passing of Two Gun Flicks

Wednesday Dec. 23



The Last of the Line

Thursday Dec. 24

8"-10" Photos of our Players can be had by sending to Publicity Dept. 15 Cents for one - 50 Cents for set of 4.
A WONDERFUL LOBBY DISPLAY
22"-28" Photo layouts in Character makeup of Mabel Normand, Gias Chaplin & Roscoe Arbuckle 20 Cents each.



In the Sage Brush Country

Friday Dec. 25

Released Exclusively through the Mutual Film Corporation

NEW YORK MOTION PICTURE CORPORATION

LONGACRE BUILDING 42ND ST. AND BROADWAY NEW YORK

SEE AMERICANS FIRST

Flying "A" and American "Beauty"
Feature Films
MADE IN U.S.A.

WHEN A WOMAN WAITS



A Fascinating Story of
Love and Devotion Replete
with Heart Interest.

Featuring ED COXEN
and WINIFRED GREEN-
WOOD.

Direction of Henry Otto.
Release Monday, Dec. 28th,
1914.

AMERICAN BEAUTY FILMS.

"LOVE KNOWS NO LAW"

Delightfully pleasing comedy drama. You are bound to enjoy this.

Featuring JOSEPH HARRIS and VIRGINIA KIRTLEY.

Direction of Frank Cooley.

Release Tuesday, Dec. 29th, 1914.

"THE UNSEEN VENGEANCE"

A fascinating fireside drama visualized.

Featuring VIVIAN RICH, HARRY VONMETER, JACK RICHARDSON, and an all star cast.
Direction of Thos. Ricketts.

Release Wednesday, Dec. 30th, 1914.

AMERICAN FILM MFG. CO.

CHICAGO



We have secured good advertisers to talk TO YOU. Listen to them!

RUNAWAY JUNE

R U N A W A Y

THE MAN WITH THE
BLACK VANDYKE



LOVE

THE PLOT OF RUNAWAY JUNE CONTAINS THE STRONGEST LOVE ELEMENT EVER SHOWN IN A SERIAL—LOVE IN ALL DEGREES LOVE AT ITS PINNACLE

SUSPENSE

YOU HOLD YOUR BREATH IN WONDER—IN AWE—AND IMPATIENCE—YOU WAIT IN BREATHLESS INTENT AS YOU WATCH THE SCENES FLIT BY IN THIS GREAT SERIAL SERIES,

MYSTERY

THE PLOT OF RUNAWAY JUNE BREATHES MYSTERY—IT MYSTIFIES—ENCHANTS AND HOLDS YOU SPELLBOUND FROM START TO FINISH

MONEY

THE GREAT GOD GOLD DOMINATES THE THEME IN RUNAWAY JUNE—IT PROMPTS JUNE—IT LEADS THE MAN WITH THE BLACK VANDYKE ON AND DOMINATES THE STORY

Y J U N E

REVENGE

REVENGE IS SWEET
—BUT IT LEADS TO
BITTER REMORSE
—T O H E A R T
ACHES AND PAIN.
REVENGE IS IN NED
WARNER'S HEART
AND IT MUST BE
APPEASED.

HATRED

THE UNDERLYING
MOTIVE OF ALL
CRIME—HATRED—
PROMPTS NED AND
SPURS HIM ON TO
SEEK REVENGE ON
HIS ARCH ENEMY
THE M A N WITH
T H E B L A C K
VANDYKE

BOOK RUNAWAY JUNE NOW—DON'T WAIT
ONE MINUTE—YOUR COMPETITOR WILL GET
IT FIRST UNLESS YOU RUSH!! RUSH!! RUSH!!
NO MATTER WHAT SERVICE YOU ARE USING
YOU CAN BOOK RUNAWAY. JUNE NOW BY
CALLING ON OUR REPRESENTATIVE AT ANY
MUTUAL EXCHANGE.

RELEASED BY SERIAL PUBLICATION CORPORATION

PRODUCED BY

RELIANCE MOTION PICTURE CO.

29 UNION SQUARE NEW YORK CITY

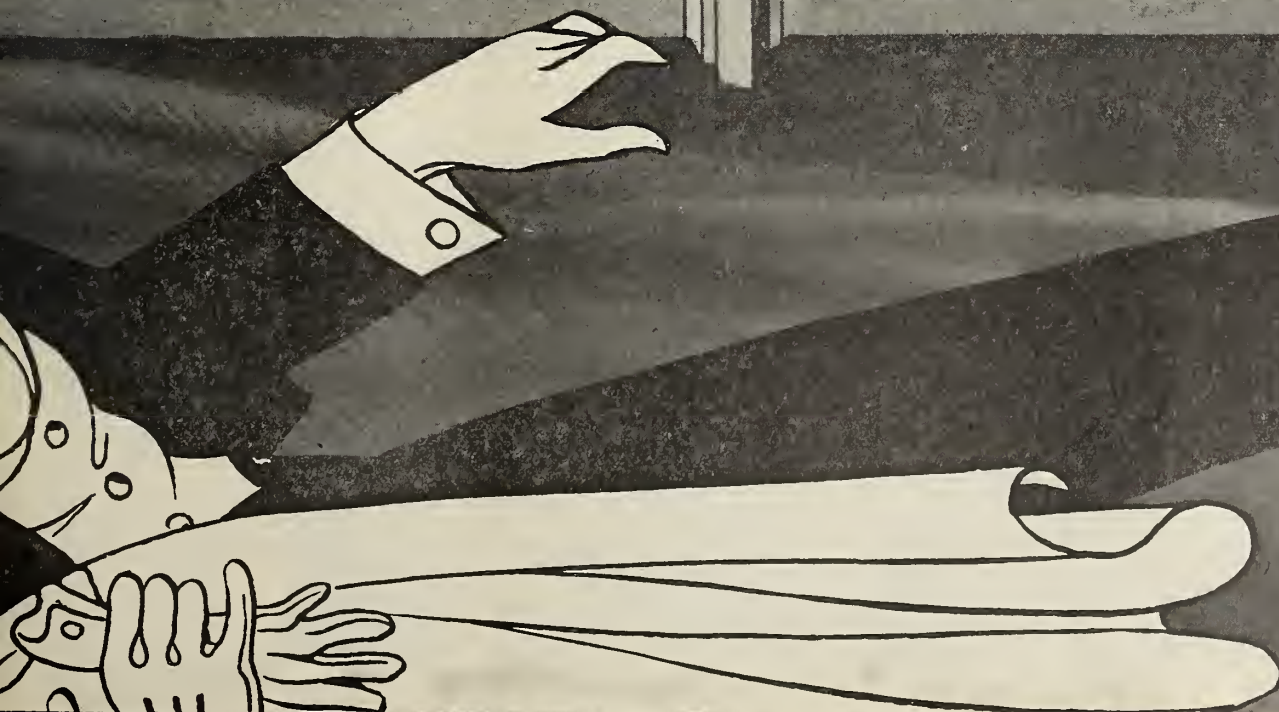

"Rescue of the Stefansson Arctic Expedition"

Russian Official
and Native Life
in Siberia.



STEFANSSON STARTING ON HIS LAST DASH NORTH OVER THE ICE IN HIS EFFORT TO REACH BANKSLAND. (SINCE STARTING, THE PARTY HAS NOT BEEN HEARD FROM.)

ANIMALS OF THE FROZEN NORTH THREE FEATURE PICTURES IN ONE

The Best of 50,000 Feet of Film Condensed into the Greatest Feature Ever Released

SHORT SNAPPY SCENES—NO SUSPENDED INTEREST
DRAMATIC — HISTORICAL — EDUCATIONAL

This Picture has had wonderful Newspaper and Magazine Publicity. The world is waiting to see it. State rights now selling. Film buyers communicate at once regarding your territory

SUNSET MOTION PICTURE COMPANY

110 W. 40th St., New York, Suite 401

Hearst Building, San Francisco, Cal.



WALRUS HUNTING IN THE ARCTIC ZONE



"WATCHFUL WAITING."
CHIEF ENGINEER MONROE OF THE "KARLUK" TAKING HIS TURN ON THE LOOKOUT

A Comedy of
Realization



A Great Story
A Great Picture

Flamingo Film Company

PRESENTS

**“WITHOUT
HOPE”**

ELAINE STERNE'S PRIZE WINNING
COMEDY DRAMA

IN FOUR ACTS

Released December 20

A SUMPTUOUS PRODUCTION

FRED MACE, DIRECTOR

THE CAST

MARGUERITE LOVERIDGE	CATHERINE PROCTOR
MARY CHARLESON	GERTRUDE BARRETT
CAROLINE RANKIN	KATHLEEN HAMMOND
WILLIAM MANDEVILLE	DAVID ANDRADA
HARRY KENDALL	JOHNNY DOYLE

AND SIXTY OTHERS

NOW BOOKING

SAWYER FILM CORPORATION

1600 Broadway

New York

SOLE DISTRIBUTOR

ALCO FILM

PRESENTS

THE INIMITABLE COMEDIENNE

MARIE DRESSLER

SUPPORTED BY
CHARLES CHAPLIN & MABEL NORMAND

IN THE WORLD'S
GREATEST COMEDY



TILLIE'S PUNCTURED ROMANCE

A RARE & RIOTOUS WHOLESOME COMEDY
RELEASED ^{ON} ALCO PROGRAM
DEC. 21ST

ALCO FILM

218 W. 42ND ST.

ALCO

CORPORATION

ALL STAR FEATURES POPULAR PLAYS & PLAYERS B.A.ROLFE PHOTO PLAYS
LIFE PHOTO FILM CORPORATION

OFFER
THE FORTHCOMING RELEASES ON THE ALCO PROGRAM

- DEC. 7 MADAME OLGA PETROVAIN. "THE TIGRESS"
- DEC. 14 MABEL TALIAFERROIN. "THE THREE OF US"
- DEC. 21 MARIE DRESSLERIN. "TILLIE'S PUNCTURED ROMANCE"
- DEC. 28 FLORENCE NASHIN. "SPRINGTIME"

THE FORTHCOMING RELEASES ARE BUT A CONTINUANCE OF
THE POLICY TO PRODUCE ONLY QUALITY

NOW PLAYING
AND PROCURABLE AT ALL ALCO EXCHANGES

- ETHEL BARRYMOREIN. "THE NIGHTINGALE"
- ANDREW MACKIN. "THE RAGGED EARL"
- JACOB P. ADLERIN. "MICHAEL STROGOFF"
- CHAS. A. STEVENSONIN. "SHORE ACRES"
- BEATRIZ MICHELENAIN. "SALOMY JANE"
- THOS. JEFFERSONIN. "RIP VAN WINKLE"
- ALL STAR CASTIN. "LITTLE LORD FAUNTLEROY"
- DIGBY BELLIN. "EDUCATION OF MR. PIPP"

IN TERRITORY HERETOFORE UNSOLD

- LINA CAVALIERIIN. "MANON LESCAUT"

CORPORATION NEW YORK CITY.





WILLIAM FOX

The Greatest Tragedienne in the world, the inspiration of the immortal Ibsen—the creator of famous dramatic characters, the recipient of royal decorations from the Czar, the Kaiser, the President of France and the King of Denmark—the idol of Europe—

BETTY NANSEN

is on her way to America to appear in a series of famous plays to be staged at the **WILLIAM FOX STUDIOS**. This is the first time in the history of pictures that a great European star was imported to appear in **AMERICAN-MADE FILM**.

BOX OFFICE ATTR

WILLIAM FOX, President

NEW YORK CITY, N. Y.—130 W. 46th St. Phone: Bryant 7340.
 WASHINGTON, D. C.—305-307 Ninth St., N. W. Phone: Main 1426.
 BOSTON, MASS.—10-12 Piedmont St. Phone: Oxford 4658-9.
 SYRACUSE, N. Y.—400 Eckel Theatre Bldg. Phone: Warren 119.

PHILADELPHIA, PA.—1333 Vine St. Phone: Walnut 4503.
 PITTSBURG, PA.—121 Fourth Ave. Phone: Court 1302.
 CLEVELAND, O.—618 Columbia Bldg. Phone: Cuyahoga Central 6260R Bell; Main 5677.
 ST. LOUIS, MO.—3632 Olive St. Phone: Bell: Lindel 795, Kinloch, Delmar 4363.

ANNOUNCES



Current Releases

- ST. ELMO**—Augusta Evans' Great American Classic
LIFE'S SHOP WINDOW—The Victoria Cross Sensation
WALLS OF JERICHO—Alfred Sutro's Great Society Play, with Edmund Breese and Claire Whitney
THE THIEF—Henri Bernstein's Drama of Thrills, with Dorothy Donnelly and Richard Buhler
THE IDLER—By C. Haddon Chambers, with Charles Richman

In Preparation

50 STAGE HITS

Coming Releases

- SAMSON**—By Henri Bernstein, with William Farnum
A FOOL THERE WAS—By Porter Emerson Browne, from Kipling's Vampire—Robert Hilliard's Greatest Success
THE CHILDREN OF THE GHETTO—Zangwill's Classic, with Wilton Lackaye
A GILDED FOOL—By H. G. Carlton—Nat Goodwin's Famous Play, with Robert Edeson
THE BUTTERFLY ON THE WHEEL—The Great Maxine Elliott Theatre Success—By Francis Neilson and E. G. Hemmerde
THE WORLD AND HIS WIFE—By Jose Echegarays—A William Faversham Hit

ACTION COMPANY

130 West 46th Street, New York City

KANSAS CITY, MO.—928 Main St. Phone: Bell: Main 1008, Home: Main 7253. MINNEAPOLIS, MINN.—Jeweler's Exchange Bldg. Phone: North Western: Nicollect 2493.
 DALLAS, TEXAS—1907 Commerce St. Phone: South Western: Main 2066. CHICAGO, ILL.—314 Mallery Bldg., 5 S. Wabash Ave. Phone: Central 1718.
 SAN FRANCISCO, CAL.—107 Golden Gate Ave. Phone: 4880 Market. SEATTLE, WASH.—1214 Third Ave. Phone: Elliott 1039.
 DENVER, COLO.—Ideal Bldg., 17th and Champa Sts. Phone: Main 5071. SALT LAKE CITY, UTAH—McIntyre Bldg.

WILLIAM FOX, Presents

WINSOR McCAY

(By permission of the Hearst Newspapers)

Creator of Little Nemo, Dreams of a Rarebit Fiend and Other Newspaper Cartoons

AND HIS WONDERFUL TRAINED DINOSAURUS



FOR ENTERPRISING EXHIBITORS

through

BOX OFFICE ATTRACTION COMPANY

GERTIE

Released Monday, December 28

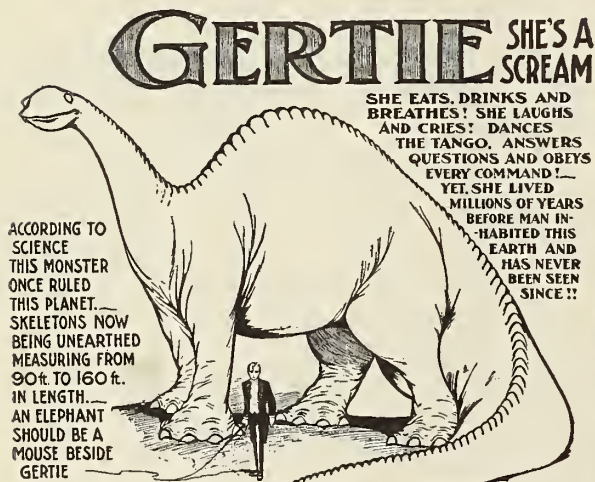

THE GREATEST ANIMAL ACT ^{IN THE} WORLD !!!

The greatest hand-drawn comedy film ever made. 10,000 drawings—A NOVELTY for NOVELTY seekers.

Write, wire or call at once for bookings

BOX OFFICE ATTRACTION COMPANY

WILLIAM FOX, President

130 West 46th Street, New York City

NEW YORK CITY, N. Y.—130 W. 46th St. Phone: Bryant 7340.
 WASHINGTON, D. C.—434 Ninth St., N. W. Phone: Main 1426.
 BOSTON, MASS.—10-12 Piedmont St. Phone: Oxford 4658-9.
 SYRACUSE, N. Y.—400 Eckel Theatre Bldg. Phone: Warren 119.
 PHILADELPHIA, PA.—1333 Vine St. Phone: Walnut 4503.
 PITTSBURG, PA.—121 Fourth Ave. Phone: Court 1302.
 CLEVELAND, O.—618 Columbia Bldg. Phone: Cuyahoga Central 6260R; Bell: Main 5677.
 ST. LOUIS, MO.—3632 Olive St. Phone: Bell: Lindel 795; Kinloch Delmar 4363.

KANSAS CITY, MO.—925 Main St. Phone: Bell: Main 1008 Home: Main 7253.
 DALLAS, TEX.—1907 Commerce St. Phone: South Western: Main 2066.
 SAN FRANCISCO, CAL.—107 Golden Gate Ave. Phone: 4880 Market.
 DENVER, COLO.—Ideal Bldg., 17th and Champa Sts., Phone: Main 5071.
 MINNEAPOLIS, MINN.—Jeweler's Exchange Bldg. Phone: North Western Nicollet: 2498.
 CHICAGO, ILL.—314 Mailers Bldg., 5 S. Wabash Ave. Phone: Central 1716.
 SEATTLE, WASH.—1214 Third Ave. Phone: Elliott 1039.
 SALT LAKE CITY, UTAH—McIntyre Building.

THE PRODUCTIONS OF
FAMOUS PLAYERS FILM CO. **JESSE L. LASKY** **FEATURE PLAY CO.** **BOSWORTH INC. and THE OLIVER MOROSCO PHOTO-PLAY CO.**
 In Association with Daniel Frohman Chas. Frohman-Henry W. Savage
 Associated with David Belasco The Liebler Company
 In Association with Oliver Morosco and John Cort
 CONSTITUTE

Paramount Pictures



*Great Scenes
 Great Plays
 Famous Authors
 Superior Producers*

These all go to make up Paramount Pictures. Attractions of this quality will surely bring to your theatre the best class of patronage.

Paramount Service is helping many exhibitors to build a permanent, profitable business.

Are you one of them?

Our nearest exchange will be glad to give you information. Write them.



Paramount Pictures Corporation
 ONE HUNDRED and TEN WEST FORTIETH STREET
 NEW YORK, N.Y.



A Colossal Success!

ZUDORA

Thanouser's Greatest Photoplay

Greatest Film Production Ever Staged!

CROWDS, crowds, crowds—
the biggest attendance ever recorded in the history of motion picture theatres is being reported from all sections of America where ZUDORA is being shown. This stupendous motion picture serial is now being exhibited at high-class theatres everywhere. Exhibitors are COINING MONEY on it!

Turned Away Thousands in Toledo!

Thousands of people were turned away from the big Princess Theatre in Toledo last Sunday. At six o'clock the house was PACKED and thousands were waiting to gain admission to see ZUDORA.

Read this telegram:

Thanouser Syndicate Corporation

Toledo, Ohio.

71 W. 23rd St., New York City, N. Y.

Zudora breaking all records in Princess and Colonial Theatres. Every episode full of startling situations. Can recommend highly to all exhibitors. O.L. Brailey.

Same reports come from New York, Chicago, Milwaukee, Seattle, and hundreds of other points.



Trade Mark Registered.

Exhibitors: Book This Big Serial Feature NOW!

Coming! *Newer Things—*
Bigger Things—in ZUDORA
Watch for New Thrills

IN episodes six, seven and eight of Zudora you will find even more remarkable scenes than in previous episodes. You'll find James Cruze in a marvelous transformation scene in which he turns into the spectacular hero which made him famous in *The Million Dollar Mystery*. You'll find **NEW** characters—a new woman of mystery—melodramatic **THRILLS** and **EXCITEMENT** galore. Watch for these spectacular events!

Helen Badgley—Thanhouser Kidlet Appears

That greatest of all child wonders—Helen Badgley, the *Thanhouser Kidlet*—breaks into Zudora and plays a sensational part. You who know the magnetic power which this clever four-year-old actress exhibits among audiences will realize instantly the value this will add to ZUDORA.

ZUDORA *already* is the most stupendous film success ever staged, but we want to let you know that in every episode to come, *even greater scenes will appear*. Be wise! Book this stellar attraction NOW! See the *Thanhouser* Syndicate representative at any Mutual Exchange in the United States and Canada.



Helen Badgley

Thanhouser Syndicate Corporation

71 West 23rd Street, New York City

Representatives at all Mutual Exchanges in the United States and Canada

Produced by *Thanhouser Film Corporation*, New Rochelle, New York, producers of *The Million Dollar Mystery*



210

Trade Mark Registered



THANHOUSER PHOTOPLAYS

TRIUMPHS IN HIGH CLASS
MOTION PICTURE PRODUCTION

In every industry you will find one organization that is recognized as the quality institution — as the producer of the highest class of merchandise in that line. In the motion picture industry the Thanhouser Film Corporation has won this honor. The exceptional merit of Thanhouser Photoplays is known throughout the world. In the Thanhouser organization are such eminent stars as James Cruze, Florence La Badie, Arthur Ashley, Sidney Bracy, Marguete Snow, Carey L. Hastings, Morris Foster, Nolan Kane, Arthur Bauer, Madeline and Marion Fairbanks, David Thompson, Mignon Anderson, Frank Farrington, Muriel Ostriche and Helen Badgley. In no other film organization will you find such a list of noted players. And back of this collection of stars, is a group of directors and executives that stand supreme in filmdom. Then, too, you will find evidence of the high quality of Thanhouser photoplays in their beautiful settings and clear photography. Three Thanhouser productions are released each week in the United States and Canada exclusively through the Mutual Film Corporation. Exhibitors can arrange bookings for Thanhouser releases at any Mutual Exchange.

For the current week we announce:

Sunday, Dec. 27th, "A Hat Full of Trouble." A one-reel comedy—full of side-splitting scenes. Interpreted by an exceptionally capable cast including Frank Farrington, Fan Bourke, Marion Fairbanks and Ethyle Cooke.

Tuesday, Dec. 29th, "Lucy's Elopement." A two-reel drama by Howell Hansel. In the cast are Justus D. Barnes, Mignon Anderson and Morris Foster—thus assuring a splendid production.

THANHOUSER FILM CORPORATION

NEW ROCHELLE, NEW YORK

69

"When You See It
In 'The News'
It's NEWS"

Motion Picture News

HAS THE QUALITY CIRCULATION OF THE TRADE

"The Exhibitors"
Medium of
Communication"

TEL. 7650 BRYANT

TWO HUNDRED AND TWENTY WEST FORTY-SECOND STREET

NEW YORK CITY

Volume X

DECEMBER 26, 1914

Number 25

A League Built For Business

LAST week a meeting of the national executive committee of the Motion Picture Exhibitors' League of America was held in New York City.

There were present Messrs. Pearce, Jeup, Corey, Brylawski and Wilson.

These men came from California, Michigan, Ohio, Maryland and Washington. They paid their own expenses to and in and from New York.

They left their businesses for a week or more and day after day they gathered early and sat late in session.

* * *

THEY worked hard, seriously, conscientiously, with but one end constantly in mind,—the welfare of the Exhibitors' League.

And that means the welfare of every exhibitor in this country.

No politics were discussed. They talked *business*—these men, just *plain business*. They are plain business men.

* * *

I WAS invited to attend one of the committee's conferences, and I would like to say this, in all earnestness: that if every exhibitor in the country had been in my place, had talked with these men, listened to their plans, sensed their one-minded determination and sound judgment—then every exhibitor in the United States would be a member of the Exhibitors' League.

Moreover, he would give this committee his absolute confidence and unqualified support.

* * *

THEY are honest, able men, with so sincere a belief in the necessity of organization that they make heavy personal sacrifices in its behalf.

They are out for a *business* administration—the first the League has ever had or could hope for. They are going to give the League a business administration, and there will result from their efforts an organization of such *downright business value* to the individual member that no exhibitor can afford to remain outside of it.

* * *

IT is their intention to have a permanent office which shall be a bureau of information and of helpful activity.

Data will be collected and made accessible to members which will not only direct them in their main problems of management, but be of direct and profitable assistance to them in the conduct of their daily business.

In other words, the very kind of *business* help the exhibitor has wanted, never had and does not now have.

The committee realizes the necessity of solid state or-

ganization and already this work is going on with a new vim and in a businesslike way.

* * *

THIS issue of MOTION PICTURE NEWS carries a call to the exhibitors of New York State to "get together."

The idea is an excellent one. It is a striking evidence of the new *business* policy of the national League and the new state League about to be.

The call is made to *all* the exhibitors of the state, *regardless of their affiliations with any association*. They are asked to forget politics, personalities, constitutions and by-laws and *get together* on purely a basis of *business welfare*.

President Pearce will ask for the resignation of present League officers. He will throw the meeting into an open discussion of those serious problems now menacing the exhibiting business in the Empire State.

Business committees, headed by business men, will be formed to tackle these problems *immediately*—and a business organization will be effected.

* * *

THERE is every practical reason why every exhibitor in the state should heed this call. There is no reason to keep an exhibitor away except an utterly selfish one.

Again, there is every reason why every exhibitor in the District of Columbia should act upon the forceful and dignified call for a mass meeting of exhibitors in the national capital.

To quote from this excellent appeal:

"Reckless competition among ourselves, together with the unwise policy of attempting to stand alone against combinations in other branches of the business with which we are compelled to deal, have worked great harm.

"Your money is invested and good business judgment dictates that you use every honorable means to protect it.

"*We must unite to protect that interest.*"

Similar businesslike calls have been sent out by Oklahoma and Minnesota. Read them in this issue.

* * *

BIG, broad things were done at the recent meeting of the League's national executive committee. MOTION PICTURE NEWS will have the pleasure shortly of announcing them and supporting them.

In the meantime there need not be—there must not be—the slightest doubt in any exhibitor's mind of the utter honesty and the substantial ability of President Pearce and his associates, nor of the fact that at least we are going to have a *business* League. WILLIAM A. JOHNSTON.

FABLES GOES INTO EDISON STOCK

Being "the goat" has no terrors for William Fables, for it is due partly to the fact that he is so good a goat that he has been selected for the Edison stock



WILLIAM FABLES

company of stars—not to say, of course, that Mr. Fables is not also a good actor.

In the Edison "Buster Brown" series, Mr. Fables as the wise goat companion of Buster, ever bent on trouble, made more of a hit than Buster himself. That so much humor could be extracted out of so serious an animal as the goat—and still be "life like"—was the surprise of Mr. Fables' quaint art. He also added a new character to the film version of "Fantasma," the Edison feature, as the clown's faithful ally and companion, the goat.

ALBANY RESIDENTS FIGHT THEATRE INVASION OF PINE HILLS

Special to MOTION PICTURE NEWS

Albany, N. Y., Dec. 15.

Residents of Pine Hills, one of the select locations in Albany, through the Pine Hills Association, have commenced a war against moving picture houses in the residential parts of the city. The board of managers of the association met and unanimously adopted a resolution requesting city officials to hold in abeyance all applications for moving picture permits or licenses that may come before them previous to February 1, 1915.

DIRECTOR SEAY IN THE SOUTH

Director Charles M. Seay, Edison, with Bessie Learn, Marie Le Manna and Mrs. William Bechtel, has been in Washington and North Carolina for some time filming scenes for a new play of the South. They have been having bad luck with the weather.

MARKS SELLS HOLDINGS IN PIERROT

Charles Marks has severed connection with the Pierrot Film Company, selling to the corporation all his stock and holdings.

Pennsylvania Building Code Is Killed

Proposed Law Will Probably Never Reach Legislature—Standards Committee Convinces Industrial Board That Mandatory Code Is Unnecessary

Special to MOTION PICTURE NEWS

Harrisburg, Pa., Dec. 15.

GOOD news for present owners and prospective builders of motion picture theatres throughout the state of Pennsylvania is contained in a statement obtained today by the representative of the MOTION PICTURE NEWS from the Department of Labor and Industry, at the capitol, that it is now altogether probable that the proposed law providing a mandatory building code for the construction of motion picture theatres in this state will never be introduced in the Legislature.

The Industrial Board of the Department, it is learned, has practically decided to drop the plan for the proposed law which has been so much dreaded by all the motion picture interests of the state. This decision, it was learned, has practically been reached since the Industrial Board, which is a commission appointed by the state authorities to frame legislation concerning matters affecting the work of the Labor Department, has conferred with the Committee on Motion Picture Standards, composed of various representatives of the business. This committee has about convinced the Board that the proposed code is not necessary.

This committee on standards includes managers of theatres, building inspectors

from Pittsburgh and Philadelphia, film men, insurance people, architects, motion picture operators, labor representatives and others identified closely with the business.

At the recent meeting of the Board with the committee the matter of preparing a building law and introducing it in the Legislature, the new session of which starts next month, was talked of, but since then the motion picture men have offered suggestions that, blended in a whole, have constructed a standard that is considered to be as nearly perfect as possible. In the observance of this standard all the important picture interests of the state are said to have agreed, so that a law is hardly necessary. The standard has not yet been prepared as a whole, but it will be made up of the different suggestions and recommendations already made and published in the MOTION PICTURE NEWS, and it will be prepared for the public in the course of the next few weeks.

Another meeting of the interests involved will be held at an early date, which has not yet been selected, when the entire scope of the proposed safety arrangements will be gone over, following which it is thought to be practically certain the Industrial Board will abandon the idea of advocating any mandatory legislation on the subject.

V. H. BERGHAUS, JR.

Vitagraph's Policy for the New Year

Company Will Release Every Alternate Tuesday and Saturday Three-Part Broadway Star Features on Regular Program

IN response to the many suggestions and requests of the exhibitors, the Vitagraph Company has decided to release the Three-Part Broadway Star Features in the regular program on every alternate Tuesday and Saturday, thus giving exhibitors in different localities fair opportunity of booking one of these in their programs.

The first releases will be "Two Women" on Tuesday, January 5. The second of these releases, "The Sage Brush Gal," will be on Saturday, January 16, and so on through each month. The second week of January, "The Evil Men Do" will be released on Tuesday, January 19, and "Underneath the Paint" will be released on Saturday, January 30; and so on through each month.

All the pictures will be first shown at the Vitagraph theatre, New York City, as for-

merly, and considerable publicity will continue to appear simultaneously in the daily papers. The operation of both modes of publicity will have the effect of stimulating an interest in patrons of neighborhood houses as well as acquainting the general public with the merits of Vitagraph pictures, which have long maintained a high standard of excellence.

The policy of long runs at the theatre of the company has been discontinued, and from now on the pictures will be put on only long enough to serve as an advertising aid to exhibitors.

The Monday releases will be changed from a drama to a comedy, making three Vitagraph comedies a week—Monday, Wednesday and Friday. On Saturdays a two-part comedy or drama will be released for booking.

Alco Will Make Series of Star Releases

Companies Engage Orrin Johnson, Irene Warfield, Catherine Countiss, William T. Tooker, Minnie Dupree, Jane Cowl and Ethel Barrymore

THROUGH its various producing companies, the Alco Film Corporation is making a series of star releases.

Among the many new engagements for the forthcoming season are those of Orrin Johnson and Irene Warfield for B. A. Rolfe Photoplays, Inc. Catherine Countiss, William H. Tooker and Minnie Dupree are recent engagements by the Life Photo Film Corporation.

Jane Cowl and Ethel Barrymore have

been engaged for further productions by the All Star Feature Corporation, while Thomas Jefferson and Adelaide Thurston and Madame Olga Petrova have signed contracts with Popular Plays and Players, Inc.

B. A. Rolfe announces the securing of Mrs. Fiske's famous dramatic vehicle "The High Road." Whether Mrs. Fiske herself will appear in her original role cannot be said at present, but Mr. Rolfe expects to make a definite announcement soon.

FINAL HEARING IN PATENTS COMPANY SUIT

Arguments Heard by Judge Dickinson in Federal Court at Philadelphia—Edwin P. Grosvenor, Special Assistant to Attorney-General Gregory Presents Side of the Government and the Defendants Are Represented by a Brilliant Array of Legal Talent

Special to MOTION PICTURE NEWS
Philadelphia, Dec. 16.

GREAT excitement has prevailed in certain motion picture circles this week over the Government suit brought to dissolve the Motion Picture Patents Company.

The argument was heard before Judge O. B. Dickinson of the Federal Court. Edwin P. Grosvenor, special assistant to Attorney General Gregory, upheld the side of the United States, while the defendants were represented by a large array of legal talent.

Congressman R. O. Moon, of Philadelphia; Charles F. Kingsley, James H. Caldwell, Henry Melville, Charles K. Zug, Samuel O. Edmonds, James J. Allen, H. K. Stockton, George F. Scull and Archibald R. Watson, all of New York; Melville Church, of Washington; George Wills and Fred H. Williams, of Baltimore, and David J. Meyers, of Philadelphia, were retained by the 13 corporation defendants and 21 individual defendants named in the Government's dissolution suit.

These are: The Motion Pictures Patent Company, of New York, principal defendant; the General Film Company, the Biograph Company, of New York; Thomas Edison, Inc., Orange, N. J.; Essanay Film Manufacturing Company, Chicago; the Kalem Company, Inc., New York; George Kleine, Chicago; the Lubin Manufacturing Company, Philadelphia; the Melies Manufacturing Company, Chicago; Pathe Freres, New Jersey; the Selig Polyscope Company, Chicago; the Vitagraph Company of America, New York; Armat Moving Picture Company, Washington, D. C.; Frank L. Dyer, Orange, N. J.; Harry N. Marvin, J. J. Kennedy, Samuel Long, J. N. Borst, of New York; Siegmund Lubin, Philadelphia; Gaston Melies, George K. Spier and W. N. Selig, of Chicago; Albert E. Smith, Brooklyn, N. Y.; and William Pilsner, Orange, N. J.

The Government charges that the alleged monopoly was formed in 1908 by practically all of the manufacturers of motion picture films in the country.

Charges of the Government

Under an agreement made by these concerns, the Motion Pictures Patent Company was made, the Government alleges, the holding company of all the patents that have ever been issued in Washington. A list of theatres was then prepared and no film exchange was allowed to distribute films to any theatre except those named on the list, it was charged. Uniform prices and rules were made, and if the middleman did not observe the orders of the so-called trust, his supply of films was cut off and he was forced out of business, it was declared.

In a brief outline of the Government's case, Mr. Grosvenor referred to the Supreme Court's decisions in the Standard Oil and Tobacco cases, and contended that the present action came within the scope

of the rulings in these cases. In reply Mr. Moon contended that at the organization of the company in 1908 there was a disastrous feud among the motion picture factions, and that because of this warfare and the general infringement of patent rights by dissenting interests, the paths of commerce were obstructed.

He further declared that the Motion Picture Patents Company was only a trustee of the patents company and not designed to absorb the business of competitors. In the ten years before the organization of the company he claimed that there were so many infringement suits

said, a film at 7:50 p. m. for an exhibitor who wished to show this film in Baltimore before noon.

The hour set for releases by the General Film Company being 8 a. m., Mr. Swaab was fined \$10 a minute, \$100 in all, by the manufacturers, the penalty of non-payment being the curtailment of his supply, Mr. Grosvenor asserted.

The Government's lawyer wished to know "if such action were not an arbitrary interference in interstate commerce with the rights of an American citizen."

Alleges 1,600 Per Cent. Profit

Mr. Grosvenor claimed that in the first 18 months of its existence the General Film Company expended more than \$2,000,000 purchasing independent exchanges and paying manufacturers, and yet paid 7 per cent. on the preferred and 12 per cent. on the common stock to its shareholders.

In fact, emphatically declared the lawyer, on an investment of \$10,000 each, ten manufacturers made a profit of 1,600 per cent. in 1911.

During the progress of the trial the courtroom was filled with all sorts of moving picture paraphernalia showing the different inventions and patents involved in the suit.

Pictures were shown the judge and every point possible brought out by the counsel on both sides. The counsel for defense will submit further arguments. Chas. F. Kingsley assisted Mr. Moon in the conduct of the case and made some of the arguments.

The suit was begun on Tuesday, December 8, and continued daily, the Court even holding a night session on Thursday to facilitate the progress of the proceedings. The final arguments in the suit were heard on Friday morning. Judge Dickinson reserved his decision.

IRENE PAGE SOLOMON.

WHERE TO FIND IT	
Department.	Page.
Live Wire Exhibitors.....	29
In and Out of Los Angeles Studios	32
Looking Ahead	31
Editorials	37
Among the Exchanges.....	41
Exhibitors' Forum	39
Feature Reviews	44-48
Program Reviews	49-51
Buyers' Guide	102
Current and Coming Releases..	52, 53
Release Dates for Ready Reference	55-57
ACCESSORY NEWS	103-116

brought by rival interests that several manufacturers were almost financially ruined.

Mr. Moon further asserted that the motion picture art had increased infinitely more than any other industry in interstate commerce and he insisted that a New York exchange dealer and not the Government was the real plaintiff in this case.

Claims Patents Were Rightfully Applied

Continuing, Mr. Moon maintained that the patents instead of being applied to unlawful purposes, were employed in a normal manner to the development of business, and without the amalgamation of the patents the evolution of motion pictures would have been impossible.

In his final argument, the Assistant Attorney-General indicated to the Court the enormous profits made by the so-called trust.

He claimed the General Film Company absorbed 68 companies, and of the 116 competing exchanges before the formation of the combine, only one survives, he declared. Mr. Grosvenor also alleged that severe penalties were incurred by any exchange dealer who violated even in the smallest degree the regulations in his license.

As an example, he cited the case of Lewis M. Swaab, of Philadelphia. Mr. Swaab, in order to catch an eight o'clock train to Baltimore, had to release, it was

HORSTMANN TO ORGANIZE GRANITE STATE EXHIBITORS

President E. H. Horstmann and Harry F. Campbell, of the Motion Picture Exhibitors' League of Massachusetts, left Boston on Friday, December 18, for Concord, N. H., where they are to lend their efforts toward organizing an exhibitors' league in the Granite State. They will work in conjunction with Charles Bean, of Franklin, who requested the local league to send up its best organizers to start such an association going.

ANOTHER SUNDAY VIOLATION CASE DISMISSED

Special to MOTION PICTURE NEWS

Louisville, Ky., Dec. 15.

Magistrate Ogden, at Jeffersonville, Ind., has dismissed the action against Roscoe Heimbaugh, charged with a violation of the Sabbath law by operating a picture machine on Sunday.

AUGUST PICKS CAST FOR KINETOPHOTE PICTURES

Edwin August has picked his cast for the first picture which he will make for the Kinetophote. As has been announced, his leading woman is Bliss Milford, who has been an Edison star for some time back. The others in the cast will be Clare



EDWARD J. PEIL

Hillier, a child actress; Edward J. Peil, Hal August, Thomas J. O'Keefe, Virginia Russell and Emmet Whitney.

The picture which Mr. August will produce has been advertised as a "mysterious thing." Some ideas are to be tried which have never before been tried in moving pictures and the effects which are promised will be different from anything yet shown on the screen.

Mr. Peil, who will have the principal male role, next to that which Mr. August will take, is well known to the motion picture world. He made his stage debut at the age of eighteen years, playing then with Mme. Modjeska. He appeared in the first five-part picture which was ever made by the Lubin Company.

Hal August has been associated with his brother in pictures for some time.

READS IT FROM COVER TO COVER

Motion Picture News,

New York, N. Y.

Gentlemen: I read the "News" through from cover to cover and derive considerable benefit therefrom. I am enclosing a check for \$2 for a year's subscription.

Very truly yours,

CHAS. A. RIVA,

The Pastime,

Tilton, N. H.

Balboa Produces First of Series by Charles M. Peck

Each Story Complete in Itself, and Deals with Problems of Life—First Entitled "When Justice Sleeps" Shows Effect of Bank Peculations

Special to MOTION PICTURE NEWS

Los Angeles, Dec. 14.

THE first of the series of pictures, each complete in itself, dealing with problems of life, is being produced at the Balboa studio, Long Beach. The story is by Charles Mortimer Peck, well known Chicago and New York newspaper and advertising writer, now assistant general manager of the Balboa.

"When Justice Sleeps" is the title, and the plot deals with the life of a bank cashier who uses the bank's money. First he loses, then is aided in winning at the races by tips given by his brother-in-law, a reformed ex-convict. With this he plays the stock market and loses. With more funds taken from the bank he is able to recoup his loss and make himself independently rich.

Then comes a notice that the federal inspector is to examine the institution. He hires his brother-in-law to return the money, and he while in the bank is confronted by the president in the act of

returning borrowed funds. A fight follows in which the banker is shot and later dies. The incident causes the ex-convict to return to his former life and step by step he becomes involved, until, when the officers trail him, he goes to the home of his sister and there takes his life. The cashier is made president of the bank, and his life continues successful, even though he carries the load caused by his wife's extravagance.

Other new members of the Balboa stock company who will appear in this are Hazel Henderson, formerly with the Selig companies, and Jessie Perry, late of the California Motion Picture Company, where she took ingenue parts in "Salomy Jane" and "Mignon."

Another of Mr. Peck's stories, "The Altar of Friendship," is being filmed under the direction of Leon Kent, formerly director for the Lubin, later with the U. S. Film Company and until recently again with the Western Lubin company, who is now with the Balboa.

Omaha Exhibitors Block Sunday Closing

Committee, Headed by William Roper and R. M. Marcus, Convince Ministers and Y. M. C. A. Officials of Proper Supervision Exercised Over Pictures by Managers

Special to MOTION PICTURE NEWS

Omaha, Neb., Dec. 15.

THE anti-Sunday show crusade planned by the Young Men's Christian Association and the Ministerial Association of Council Bluffs, Ia., early in the season did not pan out. The exhibitors, aided by thorough organization and some diplomatic heads, gained their point, are now holding regular Sunday shows, and more than that, are working hand in hand with the Y. M. C. A.

By showing the ministers and the Y. M. C. A. officials that the class of pictures shown in Council Bluffs' theatres were of the best, that many people were of the laboring class and could attend no other time except Saturday night or Sunday, and that the shows being open did not affect

the meetings, the exhibitors were able to win their point.

They went about it in a fair way, a committee headed by William Roper and R. M. Marcus representing every exhibitor of the city at a meeting at the Y. M. C. A. one afternoon. The two talked for all the exhibitors and did it in such a graceful and compelling way they won their points.

In a number of shows there appeared on the screens advertisements for the Y. M. C. A., telling of the fifth anniversary of the Council Bluffs association and the advantages the institution has to offer. When churches in various parts of the city held "Y. M. C. A. Days" the exhibitors in the various neighborhoods helped advertise them.

GUY P. LEAVITT.

Dorothy Gish Is Injured by Automobile

Young Griffith-Mutual Star Dragged Forty Feet in Streets of Hollywood Before Rescued and Sustains Badly Torn Side

Special to MOTION PICTURE NEWS

Los Angeles, Dec. 13.

DOROTHY GISH, the Griffith-Mutual star, in full view of the studio crowd at Hollywood was struck by a racing automobile and dragged over forty feet before the big machine could be stopped.

Her horrified friends rushed down the road to her, found her unconscious, and among those who helped lift her into the ambulance when it came was D. W. Griffith, who has done so much to make the younger Gish sister a popular star on the Mutual program.

The director rode to Los Angeles with her, and her many other friends followed her there as best they could, by trolley, motor or carriage, as the case might be.

At the hospital surgeons discovered that

the little Mutual star had had her left side very badly torn and one toe cut off. It looked like a very bad case, but after several hours she began to rest more easily, and when Mr. Griffith finally came out and announced that she would live, but that it might be several weeks before she would be able to work again, Dorothy Gish's friends breathed a sigh of deep relief.

TOO GOOD TO MISS

Motion Picture News, New York City.

Gentlemen: I cannot afford to miss a number of the "News."

Respectfully yours,

C. B. CLARK,

Rex Theatre,

Ukiah, Cal.

CREATING A CITY FOR MAKING MOTION PICTURES

Universal City, Near Los Angeles, is a Community Devoted Exclusively to the Manufacture of Films—Its Establishment Important Because it Signifies the Security and Permanency of the Entire Industry—How William Horsley Created an Inhabitable Town Out of an Old Farm on a Rush Order

UNIVERSAL CITY, situated near Los Angeles, Cal., represents one of the most important moves yet made in the motion picture industry in this country. Not only does this remarkable plant represent great progressiveness on the part of its promoters, but it also is significant of the feeling of security and permanency which is felt throughout the film industry as the result of modern methods.

Briefly stated, Universal City is a complete manufacturing plant for the production of motion picture films, but this means so many things that it is wholly inadequate as a description.

The idea of Universal City was originally conceived by Isadore Bernstein, general manager of the Pacific Coast Studios of the Universal Film Company. Mr. Bernstein has long realized that the days of haphazard arrangements for the making of motion pictures were past, and that films could be best produced in a place specially arranged to meet the requirements of every branch of their manufacture.

Such an establishment was in part provided on the ranch which the company occupied up to May of this year, but the equipment on this place was bound to be somewhat unsatisfactory, owing to the fact that it was only under lease, and equipment of a permanent nature could not well be provided.

The lease on the old ranch expired about the middle of the year, but thanks to some very fast work on the part of William Horsley, the man who had charge of all the construction, everything was ready when the time for moving came.

Ground Suited to Purpose

The property on which the new plant has been established is one which is particularly suitable for the purpose. It is a few miles from Los Angeles on the electric line from that city. Most of the land lies on the south bank of the Los Angeles River.

The shape is irregular, with a length of about three times the width. There is a great diversity of scenery. Many varieties of water views can be obtained along the banks of the stream, and a small dam located near the mouth of a creek makes it

possible to have a little lake when needed. Scenes supposed to be in desert or arid country can be easily found, as can those representing prosperous farm and ranch regions.

A range of saw tooth hills, which are the lower portions of the Santa Monica Mountains, provide excellent backgrounds for Western mountain scenery. At a number of points best suited for this purpose operating grounds have been laid out. On this various types of outdoor scenes can be erected, especially those representing small villages, farms or city streets.

Altogether it is possible to find almost every variety short of marine views on the ranch itself, and these can easily be obtained by a short trip to one of the nearby beaches.

For a plot of its size the site of Universal City presents a surprising variety of country. Its area is approximately two hundred and thirty acres. In general the soil is very sandy. In fact Mr. Horsley found it necessary to spend two weeks building roads before he could do any actual construction work. The operating grounds were also covered, the material in their case being a heavy clay which is found on the higher portions of the property.

Horsley in Charge

When the Universal Company took possession of the ranch on about the first of May of this year it was entirely unimproved. Near the highway which passes the west end there were two or three small barns.

There were also several large fields of barley. The rest of the farm was practically in its original condition. Mr. Horsley was put in charge and told to make the dirt fly, a request which was quite to be expected, as it was then only six weeks until the company's lease would expire and it would be necessary to move.

As mentioned above, Mr. Horsley had to spend the first two weeks working on roads. This left him just about a flat month in which to construct an entire motion picture plant. On account of the shortness of the time it had already been decided to build the first structures of wood and after their com-

pletion to start work on the tile and concrete buildings which are the only sort that will be allowed when the whole city is completed.

Following this scheme the ranch was laid out in two sections, and a road called Laemmle Boulevard, after the president of the Universal Company, was built to connect the two parts.

It was at the back of the ranch, that is the part farthest from the highway—was chosen for the temporary buildings. A general view of this colony is shown in the accompanying birdseye, which was taken from the summit of a nearby hill. In the left foreground is seen the outdoor stage.

This is two hundred feet in length, and is flanked by a double row of dressing rooms. It has a wooden floor and overhead is the standard equipment of screens and other devices for obtaining the right lighting effects. This stage and all of the buildings in the group were built and equipped in about four weeks, and were ready for use when the day for moving from the old quarters arrived.

Commodious Quarters

The settlement includes stables, saddle and harness shops, and other buildings connected with the care and management of the place. Besides these are the animal pens and cages in which the various wild beasts are kept, as well as the arena depicted herewith in which animal scenes are staged.

A few of the structures are temporary, notably the sleeping quarters and general living places for the cowboys and cavalrymen, a separate house being provided for each group. Each of these is equipped with a clubroom, and other arrangements for the convenience of the men.

So far, the real architectural features of Universal City are to be seen at the front of the ranch. Here along the highway a really remarkable group of buildings has been erected. These are built in the best mission style of architecture.

They are constructed entirely of concrete and hollow tile, and they house the most modern sort of equipment for finishing



MAIN ENTRANCE, UNIVERSAL CITY

GENERAL VIEW OF UNIVERSAL CITY

RESTAURANT AT THE ENTRANCE



RANCH RESTAURANT

ARENA FOR THE ANIMAL FILMS

ADMINISTRATION BUILDING

films as well as general offices, a restaurant, dressing rooms and the like.

The two huge eucalyptus trees shown in the accompanying cut mark the main entrance to Universal City. They stand on the edge of the highway, and directly between them, set well back from the road, is the doorway to the general office or administration building, which is the center of the group.

A rear view of this, showing the structure on the roof and the small balcony is also given. The room on the roof is the office of Mr. Bernstein, and the balcony commands a view directly down the three hundred foot out-door stage, which is just being completed.

This stage is sixty-five feet wide, and its center line is directly to the rear of the administration building. It has a double row of concrete dressing rooms for the use of the regular players. A special building some distance away is provided for the use of the extras.

Visitors Always Welcome

Closely adjoining the twenty-two room administration building is the restaurant. This is so constructed that it can be used both by Universal employees and by visitors to grounds. Visitors will be welcome at all times, and it is expected that many tourists on their way to or from California's two expositions next year will stop to see how motion pictures are made at Universal City.

On the opposite side of the quadrangle at the main entrance is the laboratory building, and near it the theatre. The laboratories are of the most modern sort of construction and have separate work rooms for developers and printers, camera men and directors. The directors have ample opportunity to cut and arrange their own film.

The theatre has three projection rooms in which sample prints can be run off and judged. As can be seen from the photographs this entire colony of buildings at the front of the ranch forms a group which is as attractive as it is useful. It represents the highest achievement in the line of special equipment for the making of motion pictures.

In connection with the general plan of Universal City it is interesting to note that it has a complete water and sewage system of its own, each with about four miles of pipes. The water is supplied from four wells, each with a pumping plant and tank.

There is also a very large garage which is being used as an indoor studio pending the completion of a building which has been started for that particular use.

The entire plant was designed on the spot, and much of the furniture was built

there or in the Hollywood shops of the Universal Film Company. Thus Universal City was conceived, designed, laid out and built by Universal men for the sole purpose of producing the best pictures for the Universal program.

Betty Nansen to Pose for Fox Pictures Here

Danish Actress, Only Woman to Receive from King of Denmark the Order of Literature and Art, on Way with Large Retinue

BETTY NANSEN, conceded to be one of the greatest exponents of tragic and heavy character roles on the stage, is on her way to America to pose for a series of William Fox's productions extraordinary. The actress, who is leading woman of the famous Theatre Royal of Copenhagen, Denmark's endowed and government-managed playhouse—a temple of the drama which is to northern Europe what the classic Theatre Francaise is to France—has been decorated by the King of Denmark with the coveted Order of Literature and Art. She is the only woman ever to be so signally honored.

Throughout Denmark, Norway, Sweden, Germany and Russia Miss Nansen is hailed as one of the greatest interpreters of Ibsen

and Shakesperian characters on the boards today.

Miss Nansen is coming to this country on the United States of the Scandanavian-American line. She brings with her a retinue of servants and an immense variety of wardrobe carried in forty-five trunks. The estimated value of the stage costumes she possesses is upwards of \$50,000. On account the mined northern seas the United States may be delayed.

Present arrangements are that Miss Nansen will be met down the bay by a delegation of Scandinavian residents of New York and other cities, headed by the Danish ambassador and the Danish consul at this port. After her arrival a reception will be tendered to Miss Nansen.

Alliance Will Have Entire Floor for Offices

Company Makes Extensive Alterations and Additions to Its Premises in the Leavett Building, on Forty-sixth Street

A BIG crew of workmen have been working overtime making extensive alterations and additions to the executive offices of the Alliance Film Corporation. The offices when completed will occupy practically the entire eleventh floor of the Leavett Building in West Forty-sixth street, New York City.

The new additions were made imperative by the rapid growth of the firm's business, and will give much needed accommodation to all the departments.

One of the features of the new arrangement will be the projection room. This will be one of the few private exhibition halls having the advantage of adequate ventilation.

Mr. Cobe, the general manager, and his secretaries will occupy a suite of offices to the front, while between the offices of Mr. Kosch, the treasurer and the auditing department, in a large double office, will be the headquarters of the advertising and publicity manager.

The sales and the shipping departments together with the exchange will have commodious quarters at the rear of the main hall.

BOSTON EXHIBITORS HAD BUSINESS BANQUET

Special to MOTION PICTURE NEWS

Boston, Dec. 17.

A dinner of the Motion Picture Exhibitors' League of Massachusetts was held Wednesday evening, December 16 at the Georgian. A social session and business meeting was held, and the report on the recent ball at the Arena, made by Samuel Grant, chairman of the executive committee in charge of the affair. A campaign was also put under way to increase the membership in the organization, and plans to this end will be submitted. The present membership is about 140, and it is purposed to raise this to 200 by the first of the new year.

LIVE WIRE EXHIBITORS

EDITOR'S NOTE.—It is the desire of "Motion Picture News" to include under this heading novel advertising ideas, successful schemes in the management, decoration and equipment of the theatre—everything, in fact, done by the exhibitor to stimulate his trade. We invite every exhibitor to write us about any new enterprise he has; also to come to us for advice or information along any line. Address: Editor, "Motion Picture News," 220 West Forty-second Street, New York City

THEATRES CANNOT DEPEND SOLELY UPON LOCATION

"ON account of its location that house will run itself," said the interviewer to A. J. Gillingham, the owner of a leading Woodward avenue picture theatre, in Detroit.

"Don't you think so," came the answer right back. "Whenever a theatre in a good location does a big business, people get the impression that the house will take care of itself. That is absolutely wrong. The better the location, the more attention a theatre needs.

"Take in our particular theatre; our people demand a lot of personal attention and must have courteous treatment from the ticket seller to the ticket taker, to the usher and to the boy who opens the exit doors. And the manager of the theatre must be on the job every minute to see that the attaches of the house live up to these requirements.

"Quite often, and, yes, very often, employes forget their duties and become impatient and gruff to patrons; these facts seldom come to the manager's attention, and as a result the theatre loses patronage and the owner wonders why. There is no line of business that needs so much watching as the moving-picture theatre; people are coming and going constantly, the attractions differ each day, and the patrons must be satisfied.

"The manager must know what the patrons of his particular theatre prefer in the way of attractions and must cater to them. A theatre must be kept looking clean, so that a live manager has his hands full trying to keep up the appearance of his theatre, seeing that his patrons are properly handled and giving them the proper kind of entertainment. The bigger the house the more business it does, and the better the location the more personal attention is required."

NURSERY IN THEATRE BASEMENT

IN the lobby of Clune's theatre, Los Angeles, is an attractive sign, the size of a one-sheet, bearing the following:

WE CHECK THE BABY

You Enjoy the Show

"What-d'-mean, 'We check the baby?'" a stranger asked Manager W. W. Dunlap the other day, whereupon he took him to the basement. There was a play room with sand pile, hobby horses, swings, blocks and other indoor sports for the children. In charge was a pleasant-looking nurse, who at the time was caring for four children.

The woman explained that she cared for all the way from 15 to 30 babies each day and added:

"There will be more left with me as soon as the women find out I am here." And no doubt there will.

FREE BALLOONS ON CHILDREN'S DAY

MANAGER ALPHA FOWLER has inaugurated children's day at the Alpha, Atlanta, Ga., with great success. As a special inducement to the young people a big, durable balloon was given to each child under the age of 12, with the result that the Alpha was very desirably advertised in every section of the city.

Manager Fowler announces that he will give away souvenirs for children's day each week and that on these days films especially censored for the young will be shown.

The first day's attendance indicated great success for Mr. Fowler's plan. The Alpha is one of Atlanta's newest theatres and is already one of the most popular.

"BREAD CAST UPON THE WATERS"

BREAD, indirectly, has been useful in gaining admission to film exhibitions in New Haven. The L. L. Gilbert Baking Corporation issues a premium coupon with each loaf of its patent Butter-Krust bread at a cash value of one-half cent in redemption at the motion-picture theatres.

So far, Wilcox's theatre, at Savin Rock, has done more of this business than other exhibitors. The coupons are only good for children's admissions, ten being exchangeable for one ticket to a matinee performance. Saturday's matinee at Wilcox's usually finds the house full of Butter-Krust kids.

A NEWS SUBSCRIPTION IS MONEY WELL SPENT

Motion Picture News, New York City.

Gentlemen: I am enclosing check to renew our subscription to the "News." We feel that the money is well spent. From our viewpoint your magazine is very fair and just on all subjects of vital interest to the exhibitor at large, and we thank you as a member of the M. P. E. L. of America for the interest you display in our order. Wishing you every success, we are,

Yours truly,
ESTES & ESTES,
Square Town Electric Theatre,
Brooklyn, Mich.

APPEALING TO PATRIOTISM OF SCHOOL CHILDREN

MANAGER MACK, of the Crescent theatre, Syracuse, N. Y., noticed the announcement that Edison was going to release the "Midnight Ride of Paul Revere" and accordingly he wrote his exchange requesting that same be booked him.

Three days before the feature was to be shown Manager Mack got busy on the telephone, talked with the principal of every school in Syracuse, told them that the picture was something that every school boy and girl should be permitted to see and requested that the announcement be made to the children in their rooms by their teachers.

A few of the principals refused for various reasons, but the majority were pleased to comply, and in some instances expressed their appreciation of the fact that the motion picture people were trying to cater to the school children.

Two days before the showing Manager Mack secured the loan of a gatling gun, old rifles, guns and various other war implements from the local armory which he placed on exhibition in his lobby. In front of the cannon appeared a neat sign:

DON'T MISS THE MIDNIGHT RIDE OF PAUL REVERE

FRIDAY

Historically Correct in Every Detail

The Crescent played to big business afternoon and evening and the advertising which did the trick cost the house nothing. Why is it that other two-reelers in the regular program could not be boosted in the same manner?

WANTED! A LIVE WIRE!

THERE is a good chance for a "live wire" exhibitor to locate advantageously in a "live wire" suburb of Cincinnati. Citizens of College Hill, which is located about eight miles from the heart of the city, have demonstrated that they would welcome the coming of a motion picture theatre. The College Hill Boosters Club, a civic organization, has met this demand by giving its own picture show.

Before College Hill was annexed to Cincinnati, it transacted its own municipal business in a town hall. The auditorium of this building has now been converted into a motion picture theatre, and on Wednesday and Saturday evenings of each week a show is given for the benefit of residents in the suburb. The attendance so

far have filled the hall at each of the two performances given each night. The hall has a seating capacity of 300.

Programs of five reels each are shown at each performance. An admission price of ten cents is cheerfully paid by the suburbanites for this amusement. The club has made a special offer in selling family books of tickets each containing 11 tickets for \$1.00. It seems that somebody is overlooking a good bet here.

DONALD MACKENZIE GIVES A DINNER

Donald MacKenzie, who has been directing the last episodes of "The Perils of Pauline," gave a dinner at the Hotel McAlpin on the night of Sunday, December 6, to the Patheites, both in the studio and office, who have been co-operating with him in his work. Those present were: Fritz Whatne, who presided as toastmaster, Kyle, St. Germain, Mink, Jack Disch, Mohn, Van Arsdale, Steuernagel, Heinz, Zapetti, Miss Pearl White, Donald MacKenzie, Frank Lang, Alec Thompson, Harry Crandall, Lefty Miller, Frank Redmond, Mme. Staatz, Johnny Meighan, H. Stoker, Davidson, Miss Hannah Cohen, and G. Bardet. Everybody had to make a speech. The dinner lasted six hours and all agreed that it was none too long.

AGNES VERNON'S QUICK RISE TO STARDOM

Agnes Vernon, who entered the extra list of the Universal West Coast studios last February and is now one of the most popular leads of the company, was born in Oregon in 1894.

On the removal of her family to Chi-



AGNES VERNON

cago she attended a convent in that city. She received the rest of her education in a similar institution in Kansas City, where she remained until the family went back west in November, 1913.

In less than eight months Miss Vernon has risen to a place of prominence in the Nestor dramas under the direction of Charles Giblyn.

Famous Players Obtains Rights to "Bella Donna"

Will Present Pauline Frederick in Film Version of Famous Hichens Novel and Drama to Be Produced in Florida

THE Famous Players Film Company will shortly begin an elaborate film production of "Bella Donna," dramatized from the celebrated novel of Robert Hichens, by J. B. Fagan, in which Pauline

ical conditions of the Southern Atlantic coast being ideally suited for the environment of the play. The film version will be produced under the direction of Edwin S. Porter and Hugh Ford.

"Bella Donna" brought stellar distinction to Mrs. Pat Campbell in England, and it was also in this play that Mme. Alla Nazimova won one of her earliest American triumphs. With the thrilling story itself, the exotic atmosphere of Egypt and the desert, the magic of the mysterious and sinuous Nile, so strangely like the dangerously beautiful and alluring heroine, "Bella Donna" promises much that is valuable in a photoplay.

Pauline Frederick will play the part of Ruby Chepstow, known to her admirers as "Bella Donna," who, falling in love with a handsome and wealthy son of Egypt, deliberately tries to destroy the man who loves and trusts her, and who has given her his name, in order to be free to wed the Egyptian prince. How the husband is saved by a friend who visits Egypt and unravels the deadly plot, and how a poetic justice is meted out to the beautiful siren, who is at last enmeshed in the toils she herself had woven, is picturesquely and grippingly developed in this unusual drama.

Pauline Frederick, who has won a personal triumph in the current success, "Innocent," is under contract with the Famous Players Film Company for her exclusive motion picture services.



PAULINE FREDERICK

Frederick will be presented in the title role. Miss Frederick and supporting company will be sent to Florida for the exteriors, the atmospheric and geograph-

New Year Brings Changes in Universal Program

Tuesday Crystal, Wednesday Joker and Saturday Frontier to Be Discontinued—"Big U" Brand, Second L-KO and Powers Replace Them

BEGINNING with the week of January 4, 1915, the following changes in the Universal program will go into effect:

The Tuesday Crystal will be discontinued after the release of December 29, and in its place will be released the new Universal brand, the "Big U," featuring Sidney Eyres in one company and Murdock MacQuarrie in another company.

The Tuesday Nestor, which has heretofore been a drama, will be confined to comedies only beginning with the release of January 5. This new company will be directed by Eddie Lyons and will feature Billie Rhodes and Jack Dillon.

The Wednesday Joker will be discontinued and replaced with the second release of the L-KO, featuring Billie Ritchie, Pathe Lehrman, Gertrude Selby and Louise Orth. This goes into effect January 6.

The Thursday Imp will be transferred to Friday, and will be replaced with the second release of the "Big U," featuring Sydney Eyres in one company and Murdock MacQuarrie in another, same to go into effect January 7.

The Friday Powers will be transferred to Saturday, and will be replaced with the Imp beginning with Friday, January 8.

Saturday Frontier will be discontinued. This brand will be replaced with the Powers, beginning with Saturday, January 9.

In looking over the attached list showing the arrangement of the program in detail, it will be noted that there is a feature brand scheduled for each day, namely: Monday, Victor; Tuesday, Gold Seal; Wednesday, Eclair; Thursday, Big U; Friday, Imp; Saturday, Bison; Sunday, Rex (all of these two reels or over).

These brands will release a two-reeler every week on the days specified. It may be necessary to deviate from this arrangement at different intervals to make allowances for the two-reelers that are often made by such brands as the Sterling, Nestor, L-KO, Powers, etc., there being no special day assigned to their features.

LYTHGOE JOINS AMERICAN

Special to MOTION PICTURE NEWS

Boston, Dec. 16.

David Lythgoe, a well-known Boston actor and singer, has left for California where he will play leading parts for the American Film Company. Mr. Lythgoe has figured in many musical productions in this city.

Looking Ahead With The Producers

HELEN GARDNER IN ANOTHER GASKILL PICTURE

Using one of the most elaborate sets ever employed in the studio of the Vitagraph Company, the first scenes in Charles L. Gaskill's latest picture, "The



HELEN GARDNER

Breath of Araby," have been taken. This set, two hundred feet in depth, required the entire floor space in the mammoth new building.

The leading role is assumed by Miss Helen Gardner.

"AVALANCHE" CAST CHOSEN; PRODUCTION UNDER WAY

The cast for "The Avalanche," the forthcoming five-part feature release of the Life Photo Film Corporation, is completed. The company started the production Monday, December 7.

Permission has been granted by the N. Y. Stock Exchange for the taking of the interior scenes, depicting a panic on the floor of the exchange.

The leads of the cast is made up as follows: William H. Tooker, Caroline French, Claire Mersereau, Little Madge Evans, Ed Roseman, Fraunie Fraunholz, Cathrine Countiss, Sue Balfour and Vivian Tobin.

Cathrine Countiss has been busily engaged for the past two weeks at her modiste's ordering an extensive wardrobe to be used in the production.

This photoplay will be released under the Alco Program.

LUBIN BURNS DOWN ANCIENT MANSION FOR PLAY

The Lubin Company gave a large crowd of interested spectators another thrill when the famous "Old Lippincott

Mansion" at G street and Erie avenue, Philadelphia, was burned to the ground under the direction of the Philadelphia fire department. The fire scenes will be used in George W. Terwilliger's new drama, "The Black Sheep."

The mansion, a two-story and a half affair, was over one hundred years old. In its day it was the center of many social gaieties and scores of distinguished men have accepted the hospitality for which Philadelphia is famous under its roof. For the past twenty-five years, however, it had been known as the haunted house and many weird legends were told concerning the spectres that dwelt therein.

In order to complete a street it was

necessary for the city to pull down the building. The Lubin Company made this much easier by purchasing the old mansion and burning it down. Several thousand spectators watched the spectacle.

MISS McCOY PRAISED AS THE MADONNA

Gertrude McCoy has received a number of commendatory letters from clergymen who were invited to a studio showing of the Edison "The Birth of Our Saviour," released December 19. In that film Miss McCoy appears as the Virgin Mary and the ministers are warm in their praise of what they term "a highly spiritual portrayal of a difficult character to depict."

Company of Sixty Will Enact "Runaway June"

THERE are more than sixty of capable actors and actresses, chosen with special regard for the requirements of the story to be told on the film, who will appear in the initial installment of Runaway June, the novel written especially for the Reliance Motion Picture Company, by George Randolph Chester, writer of the Wallingford stories and his wife, Lillian Chester. The scenario on which the fifteen installment photoplay of Runaway June is based by Marc Edmund Jones, and Oscar Eagle is the director.

George Randolph Chester has apparently loved writing about, will be impersonated by Miss Myra Brooks, who formerly distinguished herself by her work in the company of the late Richard Mansfield. Winifred Burke will be seen as the svelte and interesting *Iris Blethering*, June's closest friend, and Mademoiselle Evelyn Dumo has come all the way from Paris to play the part of Marie, maid in the Moore household, and incidentally afford herself and her parents, left penniless by three sons who have died for France a living.



NORMA PHILLIPS AND "RUNAWAY JUNE" COMPANY

J. W. Johnstone, who formerly played leads with Eclair, is to appear as *Ned Warner*, the young bridegroom in Runaway June, and June herself is to be visualized for the movie fans by Norma Phillips. Old *Aunt Debby*, the negro cook in the Moore household and a character

One of the more important roles in the play, that of *Gilbert Bly*, the man with the black Vandyke, in the wake of whose motor all the crowd comes streaming, will be embodied for screen purposes by Arthur Donaldson, who will be remembered from the cast of "The Prince of Pilsen."

In and Out of Los Angeles Studios

Special to MOTION PICTURE NEWS

Los Angeles, Dec. 13. THE ether of Los Angeles film colony atmosphere is at the present time charged with rumors of every description, but so far no receiving station has been discovered that has successfully received the facts. As the contract of Charlie Chaplin expires December 15, that of Ford Sterling and some even bigger lights, there is much speculation here. It would require an entire edition of MOTION PICTURE NEWS to tell all the stories to be heard, and then no doubt margins would be appropriated. Sufficient to say there is not a statement to be had at the offices of the companies.

Christmas festivities are planned on every hand. Producing companies will have Santa Claus come with his bags of playthings, and in some instances the entire stock companies of studios are making preparation for a big event of one kind or another. Every studio will be deserted save for the watchmen.

Willis L. Robbards, managing editor of St. Louis Motion Picture Company studio at Santa Paula, sixty miles north of Los Angeles, recently spent a part of a week here organizing a new company for the production of comedies in addition to the western Frontier brand dramas for the Universal program. Hal Clemmens was engaged as director; Lillian Hamilton, former ingenue for Usona company, as leading woman, and several other players.

Mr. Clemmens will play his own leads. Phil Walsh, for the past year connected with the U scenario department, was employed as scenario editor, and leaves a record of 61 scenarios, from slap-stick to psychological problem plays included, making up a total of 87,000 feet of negative, written within the year. Mr. Walsh

is a trooper of the first water—he had charge of stage direction for the Andrew Mack world tour several years ago, and since entering the celluloid realm, has found his stage experience of very great value.

"Love and Water"

"Love and Water" is a Sterling put over this week by Director Dave Kirkland, featuring Lloyd Ingraham and Dot Gould. All the exteriors were made at Hollenbeck Park, Los Angeles, where a flirtation, a boat ride, an accident and the wife of the street sweeper rescuing the drowning dandy brings forth situations of a comedy character.

The first John Brennon picture of the Sterling release on the Universal program will be "The German Bowler," personally directed during the past week by Fred Balshofer, manager of the Sterling company. Louise Fazenda plays the feminine lead. By the aid of soft soap the German defeats his adversary and adds a real novelty to the film.

Little four-year-old Olive Johnson, leading woman, is again with the Sterling juvenile company directed by Robert Thornby, and last week played the name role in "Olive's Love Affair," working opposite Billie Jacobs, who is proud of the fact that he is six months older. It may be added that the kiddies have worked up a real romance, and when complications arose—in the scene plot—which caused a separation for a few scenes, Olive was real peeved and displayed her first temperamental attack.

Harry W. Wulze has been added to the scenario staff of the Sterling company, after two years' success with several other companies.

Eddie Pallo, for several years with the Barnum & Bailey circus, where he was

successful in twice daily catching his partner of the trapeze act after he had turned three somersaults in the air, has been added to the stock company of the Francis-Forde special feature company, now making the six-reeler "The Campbells Are Coming," and will make a 110-foot leap from a tower into a net.

Universal Studios Help Celebration

Lankersham, a town of four thousand, celebrated the switching on of a new street lighting system for their village with a festival and carnival, Saturday evening, December 12, all the attractions for which were furnished by the several Universal producing companies gratis. A big feature was the Wild West Circus put on by the Henry McRea 101 Bison Company with animals from the U zoo.

Next Monday the Henry McRea company, with twenty or thirty extra people, will leave for Truckee, Cal., to secure "snow stuff" for the four-reel Universal feature "Ridgway of Montana." The players taking the leading parts in this are William Clifford, Rex de Rosselli, Sherman Bainbridge, Marie Walcamp and Lule Warrenton. They will spend several weeks in the high altitude where the snow is now several feet deep, and in all probability will be the only L. A. photoplay company to see a white Christmas.

Series five and six of the "Master Key" is finished and the mechanical wonder used in this, the brick circular room within a brick circular wall, is being torn away from the center of the U studio. But a few scenes for the seventh and eighth are yet to be made. In this many of the scenes will be made at Beverly Hills Hotel, located on the top of a range of foot hills, and familiar to all Southern California winter guests as a most pic-

TYPICAL SCENES FROM SOME OF THE COMING RELEASES ON THE UNIVERSAL PROGRAM



"THE LAW OF THE RANGE"
(101 Bison—2 Reels. Dec. 26)

"ADVENTURES OF TERENCE O'ROURKE"
(Victor—December 21)

"THE ACCUSATION"
(Victor—2 Reels. Dec. 25)

turesque place of the Spanish Mission type.

Burton King with Universal

Burton King, director and general manager of the Usona company, which made sixty odd pictures for foreign release and was forced to close on account of conditions in Europe brought on by the war, has been engaged by Manager Bernstein of the Universal company, and is making his first picture for the revolving globe brand. The title of this is "Roses and Thorns," in which Edna Maison, L. S. Reynolds and Ray Gallagher will play the principal parts. The scenario is by Helen Bailey and has a decidedly novel climax.

Journeying to Cario, Egypt, by the atmosphere route, the Jacques Jaccard company is this week filming number six of the Terrance O'Rourke series.

The Sidney Ayers company is making a Western picture, "The Sheriff of Shasta," in which tattooed stars, placed on the arms of brothers by an old sailor, serve to identify each to the other when in later years one becomes the sheriff, and the other induced to take part in the robbery of a stage, refuses at the last minute and is about to be convicted on circumstantial evidence when one of the gang makes a confession.

The Rex company is filming "Other People's Children," a satire on the life led by the wealthy, in which Gretchen Lederer plays a leading part. The cast includes Frank Lloyd, the director, as a



JUANITA HANSON (Bosworth)

self-made man; Helen Leslie as his daughter, and Marc Robbins and Helen Wright as a poor workingman and his wife, respectively.

The Nester drama company is making "In His Mind's Eye," featuring Murdock MacQuarrie as a blind street beggar, and by a series of fade-outs gives his life's history, shows the elopement of his daughter and later the cause of his blindness—his wife dashing a lighted alcohol lamp into his face—and then in life the discovery of the old man by the daughter. The supporting company includes Hilda Sloman, Agnes Vernon, Helen Wright and M. E. Wilson. The direction is in charge of Charles Gilbyn and the scenario by Bess Meredith.

"Changed Lives" Produced by Turner

The three-reeler "Changed Lives," written and being produced by Director General Otis Turner, will be completed by the latter part of this week. In this Anna Little plays the leading part, that of an adventurer who, when unsuccessful, becomes a Red Cross nurse located at an improvised hospital at Antwerp.

At the death of another nurse, killed by an exploding shell, she learns of a valuable estate left to the stricken companion, and decided to lay claim to it after securing evidence from letters and papers left by the nurse.

In proving her claim she employs a young attorney (Herbert Rawlinson) and succeeds in holding the legacy when the butler (William Worthington), to hide his theft of his employer's jewels, administers an overdose of headache medicine to the grandmother, who is about to expose the imposture, and the elderly lady (Laura Oakley) dies from the effect.

The Christie-Lyons company is staging a burlesque on the jewel robbery, in which a newspaper reporter (Eddie Lyons), on filling a forgotten assignment, has an opportunity to play the part of a sleuth and catches the thieves before the real detective (Lee Moran) has ample opportunity to verify his clues secured by his scientific method and he comes out a bad second.

In another Nester comedy now being filmed by Al Christie, "Pop" Manley, the oldest stock member of the L. A. film colony, is featured as the minister who gives a barn dance and old-fashioned basket auction to raise funds to pay off the mortgage on the church, which is held by the deacon, who insists that payment be made at once because the parson will not lend his aid to the deacon in a love match. The deacon bids a hundred for the basket he thinks the property of the one he loves and finding it belongs to an old spinster, to use the title, "The Deacon Swore."

Lee Moran in Funny Role

Lee Moran has just completed playing the part of a spinster in such a realistic manner that visitors at the U studio, who saw "her" smoke a cigarette on the stage, with hundreds all about, were shocked, and left with the feeling that motion picture players were surely the limit. The title of this is "A Maid by Proxy."

That speaks-for-itself gown of Fay Tincher's is being photographed again, as the comedienne is appearing as Ethel, the stenographer, in William the XIV, of the Komic series, titled "Ethel's First Case." She falls in love (again) with the young man she learns is married and brutally treats his wife. Ethel then aids the distressed wife, secures a client for her employer, Tod Browning, the attorney, and even makes faces at the low-down thing that flirted with her.

Donald Crisp, the Majestic-Reliance director, is again at the studio after an absence of several weeks, due to a dentist splintering his jaw bone in extracting a tooth. He is now directing "A Night's Adventure," in which Howard Gaye plays the part of a sojourning

physician in a small town, and finds a section man badly injured. The injured man is cared for, and after the incident the M. D., for want of recreation, takes a flyer at faro and breaks the bank.

The gamblers plan to rob him as he goes to the railroad station, but their plans are destroyed by the appearance of the section man's daughter. Walter Long has an important part, and one of the features will be a rough and tumble fight.

Spottiswoode Aitken in New Majestic

Spottiswoode Aitken is being featured in a two-reel Majestic, "The Old Fisherman's Story," a heart interest story being



MR. AND MRS. GEORGE ARLISS AND D. W. GRIFFITH AT LOS ANGELES

produced by John B. O'Brien. Others in the cast are Mary Alden, R. A. Walsh, and Jack Conway.

Love, hatred and revenge are portrayed in "A Lost Receipt," written by Frank E. Woods, for the Reliance release and produced last week by a cast composed of Eugene Pallette, Anna May Walthall and George Cosgrove. The plot hinges about a receipt which is lost and later found when being used by a little girl to curl her doll's hair. An especially constructed factory building was burned for one of the scenes of this feature.

The Cyrus Townsend Brady story, "The Child of God," is being filmed under the direction of John G. Adolfi for a Reliance release of four reels. This is a live story of the West and in the film version the part of the rancher will be played by Sam de Grasse, and the sweetheart by Francelia Billington.

This is the story of a young western man who scorns religion and for that reason the girl he loves refuses to receive his attention. Coincidentally he is forced to read the Bible when he is pressed into service as a godfather to a baby whose mother is dying. This incident causes a change in his life. He becomes a God-fearing man with an object in life, and fights for success. This picture will have a very superior cast

throughout and every effort is being made to produce a western picture of exceptional merit.

General Manager D. W. Griffith has advanced George Seigmann, who has been playing with him for the past year, to the position of director, and he is now making his first picture. "Vengeance is Mine," which will be a two-reel Majestic release. The scenario is from the stub pen of Frank E. Woods and has to do with a country girl, played by Billie West, who is tricked into a mock marriage by a city youth, who afterwards marries the girl of his father's choice because of the worldly goods in the name of her father. The country girl plans and secures revenge. Others in the cast are W. E. Lawrence and Florence Crawford.

Dorothy Gish Out of Danger

Dorothy Gish, who was run down by a speeding automobile on Thanksgiving Day, and dragged almost fifty feet before the car could be stopped, is now out of danger and her physician states she will be able to resume her work in from thirty to sixty days. Besides her foot being painfully crushed when the wheel ran over it, the little photoplayer sustained a deep cut in her side and was bruised from head to foot.

W. M. Ritchie, former newspaper man of Chicago, who has been a free lance scenario writer for the past two years, and is at present editor of "The Script," the official publication of the Photoplay Authors' League of America, has accepted the position of scenario editor of the Balboa Amusement Producing Company, following the filing of the resignation of F. M. Wiltermood.

Mr. Wiltermood will devote the next few months to the writing of a book dealing with experiences in the making of moving pictures from a series of articles he prepared for a well known magazine, sale of which has been contracted.

All animals of the Selig Zoo being used in vaudeville have been called in that they may be at the zoo for the public opening. "Princess Olga and Her Five Leopards" have arrived home from a tour of nine months, and other animals are expected from Australia and the East during the next two weeks. Work on the \$50,000 entrance to the grounds is being done by three shifts of men working day and night and Sundays, in the hope that it will be possible to fulfill Col. W. N. Selig's expressed desire that everything be completed on the opening day.

The Norval MacGregor company is filming the magazine story "Come and Take That Elephant Away," which has to do with the superstitions of a wealthy miner, who buys a medicine show outfit because of a dream. This will be a two-reel Western comedy.

Two James Oliver Curwood stories are being filmed at Sciig Jungle Zoo. Tom Santschi is directing "The Great Experiment," a story of a wealthy bachelor who cares for an orphan child after seeing the mother killed in an accident. The sets will represent London, Bombay and aboard an ocean liner, and the story brings out the fact that all people appreciate kindness, but some fail

to make a show of their appreciation. Bessie Eyton plays opposite Mr. Santschi in this subject.

Story of Corrupt Politics

The other Curwood story is in charge of F. J. Grandon. This has been named "Retribution," and is a story of corrupt politics, in which Edith Johnson and Lamar Johnstone play leads, with Franklin Hall as the huch-back, who is like the Irishman of the by-gone melodramas—he saves all.

A two-reel comedy drama, "Lonely Lovers," is being produced by E. A. Martin, with William Stowell, Edwin Wallock, Marion Warner and Adda Gleason playing leads. This has to do with the unfortunate experiences of legitimate stage players at a theatrical boarding house.

At the Selig Edendale studio "The Lady of the Cyclanens" is being filmed by E. J. LaSaint. This is from the story of the same name by Maybelle Heikes Justice which is now being published and is of a heart interest nature. The leading parts are taken by Stella Roseta and Guy Oliver.

The first four-reel feature of the Harry Pollard American company, "The Quest," was finished last week. The company spent ten days on Channel Islands, about twenty miles from the shore near Santa Barbara, where many of the exteriors were made. In this Mr. Pollard and Margarita Fischer play the leads and are supported by Joseph Singleton, William Carroll and Robyn Adair.

Director Joseph de Grasse, of the U Rex brand, is playing the lead character part in filming "Where the Forest Ends," a western story of the early days, in which fade-ins show colonial day scenes. The cast includes Pauline Bush, William Dowlan and Lon Chaney.

Savages in "Last Chapter"

Many of the fine distinctions on which much labor is spent in producing a picture are actually lost to the average beholder, but William D. Taylor and Carlyle Blackwell do not think that any detail is too slight for their careful consideration. The band of Damawa warriors used in "The Last Chapter" are typical of the stalwart, blood thirsty fighters of the West African

coast. All of them show the retreating forehead, flat nose and short kinky hair, of the pure negro blood of the West African coast. The man picked out for chief bore his insignia of office. The band upon his forehead, topped off with a plume, characterizes the height of leadership. Minor officers in the tribe are permitted to wear one or the other of these, but only blood relations of the king himself may flaunt the true scarlet plume of royalty.

The territory in which "The Last Chapter" is localized is that section of Africa stretching from the Guinea Coast inland to Lake Chad, which lies almost on the southern border of the Sahara Desert, and the intervening territory traversed by the story of the picture lies almost under the equator.

"American" Actor Near Death

"Waiting" is the name of a two-reel spectacular picture now completed at the American studio, Santa Barbara, under the direction of Henry Otto. The scenario called for a land slide which was put on in very realistic manner. In fact it was only by the quick witted work of Mr. Otto, that one of the players, George Fields, was not badly injured, if not killed.

Field was doing his part while the camera was being operated and did not know of the coming of a great rock. By signaling, the director advised the player to change his position, and thus led him away from the path of the tumbling boulder. Mr. Otto is now putting on a one-reel Indian and cowboy story in the mountains near Santa Barbara.

The Masterpiece players spent a day recently on the Pacific ocean, afloat a barge leased for the day, where one of the Little Joker's jokes of the "Truth Wagon," the December release of the company, was filmed. This consisted of John Ross (Max Figman) inducing all his friends to leave their ladies at a ball and go to see a prize fight he had arranged. The fight is pulled off on a boat and the principals were Roy Stewart of the Masterpiece stock company, and Bud Willis, former sparring partner of Jeffries, and a professional pugilist now in training for a ring bout the latter part of December. The forty-five players, all in evening clothes, caused much wonder among passengers of other boats passing during the day.



AFRICAN TRIBESMEN APPEARING IN "THE LAST CHAPTER" (Favorite Players-Alliance Feature)

ROLFE ENGAGES IRENE WARFIELD

Pretty Irene Warfield, formerly leading ingenue with Essanay and latterly playing opposite Robert Edson in Belasco's "The Girl I Left Behind Me," was engaged this week by B. A. Rolfe to appear opposite Orrin Johnson in the production of "Satan Sanderson," which will be the next release of the Rolfe Photo Plays Company throughout the Alco Corporation.

Miss Warfield, on a recent occasion when she was being sought after by a producing company, and was introduced to David Belasco, was the recipient of a sincere compliment from the great dramatist.

"Young lady," said the stage wizard, "You have been specially endowed by Providence with an abundance of beauty and your face, in addition to being beautiful, possesses that rare charm, activity and animation so seldom seen in great beauties." Last year Miss Warfield played the two leading roles in "Within the Law" for several weeks.

The actress later decided that she pre-



IRENE WARFIELD

ferred to remain in the east and it was under this specification that she was engaged by B. A. Rolfe.

Mr. Rolfe is considering a second company which will do their production work on the coast, in a studio now being completed and it is thought Miss Warfield will become a permanent feature with the Rolfe interests.

BEST OF ITS KIND

EMPIRE PHOTO PLAYS,
Storm Lake, Iowa.

Editor Motion Picture News,
New York City.

Dear Sir: I have been receiving your paper for some time, and the worst thing that I can say of the "News" is that it is one of the best of its kind that I ever read.

With best wishes for the success of your paper, I am respectfully,
K. MORELAND.

Grey, Advertising Expert, Is Young Executive

Promoter of "Runaway June" Publicity Only Twenty-nine, and Has Long Record of Success, Entitling Him to Reputation as "the Stunt Man"

A GOOD advertising man is always known by his works. When the "Runaway June" advertising started and progressed into bigness and strength everybody did not know that John Grey was back of it, but everybody did know that a keen, forceful advertising man was.

Also, when the advertising of the Mutual Companies was grouped, standardized and presented with a new and formidable pen everyone knew that some practiced and energetic hand had done it.

John Grey is one of the advertising men which the motion picture industry—just as happened in the automobile field—has taken to itself, which means he is one of the very best. He has originality—that one big asset of his profession—and the qualities that must go with it, namely, daring and energy. He is a "stunt" man and a good one. He is full of surprises and he "lands" with them—every one.

Mr. Grey was born in New York City, and after attending its public schools went to college in Philadelphia and later came back to New York and finished his education at Columbia University.

Leaving college he specialized in automobile advertising for eight years. Mr. Grey later became advertising manager of the Universal Film Manufacturing Company, and became known as "the first man to apply merchandising methods to motion pictures."

For the "Trey o' Hearts" and the "Lucille Love" series he furnished theatres using his service free advertising booklets, which proved of material assistance in drawing large crowds to see these pictures.

He is now providing houses booking the Mutual "Runaway June" series with live advertising matter sufficient for a fifteen week campaign.

John Grey is one of the youngest men in the business who holds a position of executive importance. He is only twenty-nine years old, is married and lives in New Rochelle, N. Y. He is a member of the



JOHN GREY

Republican and Screen clubs, New York, and the Wykyl Country Club, New Rochelle. Mr. Grey is a golf enthusiast, and is known for his possession of a wide circle of friends.

Say Six-Sheet Poster Is Needed with Features

Pennsylvania Exhibitors Demand Its Restoration; Will Ask It at Harrisburg—Buttner, Carrick and Libros Discuss Situation with Breitingner

Special to MOTION PICTURE NEWS

Philadelphia, Dec. 15.

J. H. BUTTNER, manager of the Mutual Film Exchange; V. R. Carrick, of the Interstate Film Company, and D. Libros, of the Picture Play House, were invited by J. Louis Breitingner, the State censor, to have a heart to heart talk on the burning question of the six sheet poster.

After much discussion pro and con it was found that the large feature film companies were loath to see the big posters return; the reason is evident.

Big paper costs money and plenty of it. When sent out to exhibitors to face wind and weather and other possible accidents, the posters return much the worse for wear.

Exhibitors do not expect the big posters with regular service, but when it comes to features they do ardently desire the return of the six-sheet poster. As a matter of fact, but 5 per cent. of exhibitors are opposed or indifferent to the large paper, albeit Mr. Breitingner believes 80 per cent. favor the three-sheet poster as the largest to be used.

One prominent manager said: "While I

can see the feature man's point of view, it is after all the exhibitor who must be considered, for he knows best what he must do to get crowded houses.

"And I can say most positively I need the six-sheet poster, not to flap in the wind, or disfigure my house, or litter up the streets, but to stand in the lobby in a neat frame. This advertises the big shows better than anything else; it draws the people to my theatre; it makes business good. I want what I want when I want it, and now I want that six-sheet poster bad, and I for one will work with might and main to get the censor's ruling overruled. Tell MOTION PICTURE NEWS to help us exhibitors on this question as they have done on others; it will be a mutual benefit all around."

Another vexed question is the matter of the price of \$2.50 on each reel, which has to be paid the censor. All of these thorns in the exhibitors' flesh are to be considered at the coming convention in Harrisburg.

Many Philadelphia film men are expecting to attend this important meeting, and hope to accomplish results of lasting benefit to the trade.

The Scenario Writer, the Director and the Censor

BY EUSTACE HALE BALL

(Late Director and Staff Writer for Reliance, Majestic, Eclair, etc.)

Some Expert Advice by a Veteran Composer of Scripts on the Wisdom and Profit of Working with the National Board of Censorship, Realizing that Their Rules Are, at Bottom, for the Greatest Good of All Concerned, in the Business as Well as Out of It

IN view of the fact that the life blood of the industry is the continual supply of fresh, virile scenarios, the great majority of which are written by "free lances," it is essential that the photo playwrights throughout the country, as well as the staff writers should get a true perspective of the activities of The National Board of Censorship.

Producing directors have learned by hard bumps against the adamant that this and that may be, and that and this may not be; yet still they continue, in an unfortunately large number of picture plays, to insert scenes and "business" contrary to these permissions and prohibitions.

Inasmuch as the Censorship Board is maintained almost entirely by the manufacturers, as a real insurance against the printing and distribution of expensive copies which might be thrown back upon their hands by the black-listing of smaller local bodies and the ever critical public who scrutinize the screen in 17,000 photoplay theatres, it behooves the scenario writer and the director to insure his own certainty of financial return and increasing artistic reputation, by thoroughly understanding the attitude of that critical Board.

To get down to "brass tacks," it is simply a case then in which the scenario writer and the director can increase the value of their own work by keeping the rules continually in mind, and, "beating the censor to it."

Censorable Details Unnecessary

To declare that risque situations, grown-up details, exposition of the methods of criminals are necessary for dramatic punch shows a complete misunderstanding of the possibilities of "struggle," the fundamental of every real play, whether on the screen or the stage.

Only the other day, a prominent publisher said to me, "The people are sick and tired of domestic muck-raking, as well as political. They want the old-fashioned kind of theme—sweet characters, decent heart interest, and a pleasant after-taste in plays and books."

"There are millions of combinations possible with the clean elements, and I tell you the fashion for prurient, morbid subjects is out of date."

He is not a publisher of poems, essays and religious works, but makes his money from popular priced fifty cent editions. He should know.

The essential matters with which the Censorship Board deals severely are lewd and suggestive scenes; wanton and brutal murders or attacks; excessive indulgence in liquor, gambling and the other evils of "fast living" without adequate punishment; criminal methods as in robbery, forgery and the like by which the acquisitive minds of young people may be instructed and imbued with a desire for imitation; themes

offensive to good taste, in matters of race, religion and politics.

"Behind the Times" Scenario Writers

So, the scenario writer who lingers in the realms of cheap melodrama, sex thrillers, vice monging is trying to reap a harvest from a field already trimmed to the stubble. His themes *must* keep pace with the fashions and the demand of the universal board of censorship—the patrons who pay the nickels, the dimes and the quarters.

Never before in the history of the business has there been such opportunity for true artistry in the development of theme and action. The production of classic plays, poems and stories, as well as the staging before the camera of famous modern theatrical successes has educated the photoplay patrons to a demand for higher grade stories, interpretation and even photography.

Every scenario writer, every director, despite the vaunted value of loyalty to the "firm," is working primarily for himself. As a business proposition, every cent saved by avoiding enforced alteration in a costly production lends added value to the scenario and to the picture into which it was developed.

From a purely mercenary standpoint, every director and playwright should have in his possession the pamphlet of rules and standards, which will be sent upon the receipt of a written request by the secretary of the National Board of Censorship, 70 Fifth avenue, New York City.

Censor Board Will Advise

From this purely mercenary standpoint, as well, the manufacturer or his scenario editor would do well to insure the general "passability" of a story on which there might be the smallest possible doubt, by sending a copy of it to one of the secretaries of the Board.

The organization is glad to give its advice on possibly dangerous points and thus save a great deal of money in advance, without cost to the director or manufacturer.

The Censorship Board is not a body organized for the criticism of the literary, dramatic or artistic qualities of plays, but this service to producers, "accessory before the fact," while not a guarantee of immunity after the production, is of no little value in many instances.

A scenario, in itself, may have no objectionable features; the director in his visualization of its scenes may add touches here and there which will necessitate cutting of a most unfortunate nature, later on. For this reason, an acquaintance with the Board's purposes, methods and development should be maintained.

The executive officers welcome

friendly, personal co-operation with the directors and the playwrights, for their work is essentially altruistic in the finest sense; it is a defense of the moralities and sensibilities of the millions of theatre patrons, and its power has been so thoroughly developed that it affords an invaluable protection to the film producers.

What the Board Has Done

When it is considered that the National Board of Censorship has been the protecting bulwark of the film manufacturer against the dangers of a legal censorship, and the almost certain growth of grafting among political appointees in the case of state or federal control, the director and playwright may consider himself not harassed by the sensible standards and sympathetic latitude shown by the executive officers and the members of the General Committee, made up of cultured men and women, who have been qualified to represent the finest and broadest ideals of the American people.

The development of the programs, features and serials based on lavish outlays of money, a highly organized, creative and interpretative technique and a commercial system of distribution and sales which ranks with the biggest factors of so-called "Big Business," with the continual stimulus of keen competition between the large number of producing companies, means survival of the fittest.

OWEN MOORE GOES TO BOSWORTH

Owen Moore is now with Bosworth, Inc., coming from New York to play opposite Elsie Janis in her new comedy drama, "Betty in Search of a Thrill."

Mr. Moore has distinguished himself as a screen artist, and in this new photoplay by Miss Janis he has every opportunity for impressively clever acting.

PROUD OF EXCELSIOR CAMERA

Harry Handworth, director of the Excelsior Feature Film Co., said recently: "I am not a little proud of the photography in my pictures. In every picture produced by the Excelsior starting in with 'The Path Forbidden,' continuing in 'When Fate Leads Trump' and 'In the Shadow,' the photography has been of the highest grade, and I am busily engaged on some lighting effects for my next picture."

LOWRY RETURNS FROM COAST

Ira M. Lowry, general manager of the Lubin Company, who for the past six weeks has been on a trip to the Pacific Coast, has returned to the home plant. Mr. Lowry gives glowing accounts of the development of the Los Angeles studio.

Motion Picture News

HAS THE QUALITY CIRCULATION OF THE TRADE

MOVING PICTURE NEWS EXHIBITORS' TIMES
Published Every Week by

EXHIBITORS' TIMES, Inc.

New York Offices..... 220 West 42nd Street
Chicago Offices..... 223 West Jackson Boulevard
Los Angeles Offices..... 427 South Figueroa Street

WILLIAM A. JOHNSTON..... President
HENRY F. SEWALL..... Vice-President
E. KENDALL GILLET..... Secretary
H. ASHTON WYCKOFF..... Treasurer
WENTWORTH TUCKER..... Ass't Treasurer

WILLIAM A. JOHNSTON..... Editor
LESLEY MASON..... Managing Editor
WILLIAM RESSMAN ANDREWS..... News Editor
H. ASHTON WYCKOFF..... Business Manager
R. M. VANDIVERT..... Advertising Manager
THEODORE S. MEAD..... Chicago Manager
J. C. JESSEN..... Los Angeles Manager

This publication is owned and published by Exhibitors' Times, incorporated under the laws of the State of New York. The offices and principal place of business are at 220 West 42nd Street, New York City. The address of the officers is the office of the publication.

Entered as Second-Class matter at the New York Post-Office.

Subscription \$2.00 per year, postpaid in the United States, Mexico, Hawaii, Porto Rico and the Philippine Islands. Canada, \$3.00; Foreign \$4.00 per year.

ADVERTISING RATES ON APPLICATION.

Copy for next issue must reach us by Tuesday, 5 p. m.

Cuts and copy are received subject to the approval of the publishers and advertisements are inserted absolutely without condition expressed or implied as to what appears in the text portion of the paper.

Vol. X December 26, 1914 No. 25

Revival of the Censorship Question Makes Organization Imperative

BY the time MOTION PICTURE NEWS is in the hands of its readers this week, the eyes of all associated with the film industry will be focused upon the Supreme Court of the United States, where the appeal of the Mutual Film Corporation from the dismissal by the United States Federal Court for the Northern District of Ohio of the injunction against the Ohio censors, is scheduled to be in hearing.

Once again, as last spring, it is time for everyone whose prosperity depends in any way upon motion pictures, to realize the momentous consequences of the action which will be taken by the nation's supreme tribunal.

* * *

THE Federal judges of the District Court in their decision last April, held, it will be remembered, that the charge, made by the Mutual, of unconstitutionality against the state censorship law was unfounded—that the State of Ohio, in creating a board to supervise and censor motion picture films, acted within the lawful limits of its police prerogatives.

The well-known reluctance of an inferior Federal court to enter into a discussion of the constitutionality of any law was reflected in the bench's decision. In effect, it politely passed the real problem along to the highest court of the land. The Ohio judges contented themselves with

pronouncing the state within its technical rights, and avoided all the graver and more radical issues.

* * *

WHAT the decision of the Supreme Court will be no one can forecast with certainty.

The tendency of that body of recent years, however, as markedly reflected in numerous decisions, has been to give broadest possible construction to the police power of the state and to place no limits to its exercise of any kind.

This may foreshadow a verdict, upholding the Ohio law, and vindicating its constitutionality.

To expect such an outcome would be no more than logical, in view of the manifest disposition of the court on all questions of state and municipal guardianship of the public welfare.

The film manufacturer and exhibitor, in the event of such a verdict, has only one other resource—to commence a campaign in every state where censorship laws now exist for their repeal by the state legislatures.

* * *

FORTUNATELY for both manufacturer and exhibitor, they have a powerful and efficient ally in the National Board of Censorship.

That body has already under way a campaign in Ohio which can hardly fail of culminating in the repeal of the law now on the statute books of the state. Exhibitors and the National Board are working shoulder to shoulder, and the law which M. A. Neff—whom the Mutual and everyone else inconvenienced by it have to thank for its enactment—foisted upon the exhibitors of Ohio, is soon likely to be a dead letter.

Events are shaping themselves in similar fashion in Pennsylvania.

There Fred Herrington in the West, Ben Zerr and half a dozen others in the East, are working night and day to perfect an organization which shall represent the united strength of Pennsylvania motion picture men, and to whose demands the Harrisburg legislators will listen with more than passive respect.

* * *

THE revival of the censorship peril ought to drive home to every exhibitor with redoubled force the imperative need of organization.

Relief is not to be looked for with hopefulness from the Supreme Court.

Without being unduly pessimistic, it will be well for manufacturer and exhibitor to look for a clean bill of health for the censors from that body.

The sooner they begin to arm themselves for a repeal campaign, the more completely prepared they will be to take up the fight the moment it becomes necessary.

* * *

AND only an organization can deal with a state legislature.

Any individual exhibitor, or any number of individual exhibitors, would be laughed out of the legislative chamber, if they came on such an errand. Politics is conducted solely by organization, and the politician does not understand anything but organization.

It is the only way to gain his respect and attention. Again be it said, that the exhibitor has a powerful and efficient means of offense and defense, ready to his hand—the Motion Picture Exhibitors' League.

The exhibitors of the United States can convert that league into the most formidable organization of its size—an organization powerful out of all proportion to its size—to be found anywhere in the world.

Their undivided and unanimous support is all that is necessary.

COASTAL STORM CAUGHT IN ANIMATED WEEKLY

At the break of the recent Atlantic coastal storm, the Animated Weekly sent down two camera men to the New Jersey coast. Cameraman J. T. Rucker secured wonderful pictures of the coast scenes after going through many harrowing experiences. He got caught by one of the huge



THE STORM AT SEABRIGHT, N. J., AS SHOWN IN THE ANIMATED WEEKLY

breakers and his camera was pretty well smashed up.

Cameraman U. K. Whipple was also on the job at Seabright, N. J., and was taking pictures on one of the houses when it caved in. He suffered from a sprained ankle, but was fixed up by a local doctor.

Five hundred thousand dollars' worth of damage was done along the coast.

LASKY ENGAGES LOUIS MANN

Samuel Goldfish announces that an arrangement has been entered into between Mr. Louis Mann, the distinguished American comedian, and the Jesse L. Lasky Feature Play Company by which Mr. Mann will make his first appearance in moving pictures under the direction of Mr. Lasky. This contract calls for Mr. Mann to star in a screen version of "Elevating a Husband," the noted com-



LOUIS MANN

edy success in which he appeared less than two years ago under the management of Werber & Leuscher.

"Elevating a Husband" was written by Clara Lipman (Mrs. Louis Mann) and Samuel Shipman. The piece was first produced at the Liberty Theatre, New York City.

Inceville Will Soon Become a City

First Step Indicated by Action of the Government in Appointing a Postmaster, the Studio Population Has Made Such an Increase

INCEVILLE, the plant and environs of Thomas H. Ince's productions for the New York Motion Picture Corporation, is to become a city. Such is the important announcement that has just come out of that part of the California coast where Kay Bee, Broncho and Domino films are made.

Already authorization has been received from the government for the permanent establishment of a post office. That in itself constitutes a big step in the organization of a city. Plans are being drawn for the erection of a building. A postmaster has been appointed. An additional route is in the process of formation and mail schedules are being arranged.

The county has taken cognizance of Inceville by reconstructing the shore road, beginning at the Santa Monica canyon and extending all the way to Topango. Work is still progressing on the job, and it is likely that within another week the men will have dropped their scrapers and oilers, satisfied that they have made a perfect highway.

County officials have done even more. They have consented to consider the establishment at Inceville of a voting precinct or two and possibly within a short time we will be hearing of the Inceville school district. Police protection and fire fighting

facilities, in addition to those of the plant itself, probably will make their entrance also, and that auspicious event may be accompanied by the intrusion of a street car line.

As far as the company is concerned it is taking great pains to meet these forthcoming improvements in the proper way. To get away to a good start an election will be held at which the various officials necessary to an up-to-date municipality will be elected.

A brand new power house has been installed and electricity now is penetrating the darkest recesses of the adjoining canyons. A mammoth blacksmithing shop is nearly completed—and when it is the herds of horses need not be taken to Santa Monica to be shod.

At present transit facilities are confined to a street car line that runs from Santa Monica to what is known as the Long Wharf—at a distance of several miles from the plant. That means that the company's stages must meet people every morning and convey them to the car every night. Frequent delays in the service have given Mr. Ince the idea of erecting a hotel, so that permanent residence may be enjoyed, if desired.

Picked Cast for Fox Feature, "The Idler"

Charles Richman, Catherine Countiss, Walter Hitchcock, Claire Whitney, Maude Turner Gordon, W. T. Carleton and Stuart Holmes in Haddon Chambers' Play

SELDOM, if indeed ever, has a more competent or better-known cast been gathered together than that selected to present the William Fox feature extraordinary, "The Idler," to be released through the Box Office Attraction Company, based on the highly successful and dramatic play by C. Haddon Chambers, one of England's foremost dramatists, which, when presented on the boards, was one of the most talked of dramas of the day.

Headed by Charles Richman, a star whose fame is equally great on each side of the Atlantic, it includes Catherine Countiss, an actress of unusual charm and ability; Walter Hitchcock, a finished artist of marked power; Claire Whitney, a beautiful and accomplished leading woman; Maude Turner Gordon, W. T. Carleton and Stuart Holmes, all of whose names are prime favorites with admirers of good stage work.

Mr. Richman as Mark Cross takes full advantage of his opportunity to develop this character, which is one of the strongest in which he has appeared. Mr. Richman's long association with Augustin Daly, at the latter's famous playhouse, where Mr. Richman played opposite Ada Rehan, and his many starring experiences, including a tour in "The Revelers," a successful play written by himself, equip him admirably for the role.

The same may be said of Miss Countiss, who plays Lady Harding. Miss Countiss is known to playgoers of every

considerable city in the United States. She has had a successful stage career almost from the moment when she left a convent and took up the stage as a vocation. Miss Whitney appeared in the leading role of "Life's Shop Window," and has played important parts in scores of big feature photo plays before she had a thorough training on the legitimate stage.

Walter Hitchcock is another actor whose experience and talent make his work stand out in everything he does. Mr. Hitchcock is a graduate of Leland Stanford, Cal., University, and was a champion hurdle racer in his college days. He has done much noteworthy work on the stage. Stuart Holmes played a leading part, opposite to Miss Whitney, in "Life's Shop Window," and is a great favorite, a position his ability fully entitles him to.

WHAT EXHIBITORS SHOULD KNOW

THE NEW CRYSTAL THEATRE,
Flandreau, S. D.
Editor Motion Picture News,
New York City.

Dear Sir: I am certainly reading the "Motion Picture News," and find it not only interesting to an exhibitor, but that it contains many things he should know.

Wishing you the best of success, I am very truly yours,

P. R. MATSON.

The Exhibitors' Forum

MOTION PICTURE NEWS assumes no responsibility for any opinion or assertion made in the columns below, nor does the publication of a letter mean that the statements it contains are endorsed by the NEWS. All letters must be signed. No attention will be paid to anonymous communications

What Exhibitors Owe to Their Organization

Editor, MOTION PICTURE NEWS,
New York City.

Dear Sir: Can the needs of the motion picture exhibitors and the accomplishments of the exhibitors' association be harmonized so that the organization can approach a perfect score?

Considering first the needs, we must decide what are actual legitimate needs. Often we think of something we think we should have and we don't think of it much more. We think perhaps the association could get it. Real applied study might reveal that it is not a need, but rather a wish or possibly a suggestion.

The exhibitor in my opinion wants only justice and a right to carry on a legitimate, clean and progressive business. This right includes many things.

What one exhibitor thinks he needs another thinks is not needed at all. Only by friendly and earnest deliberation can we decide what the needs are. I believe we are agreed that the exhibitor should not be subject to an unreasonable tax, that he should not be required to do things that the old school theatres are not required to do and that he should have the public back of him in any just effort.

He should have consideration and just prices from the film companies and should have fair treatment, even boosting from every other exhibitor. These things are reasonable. There are many other things.

Now as to these things, his association can accomplish every one of them. By having efficient officers demands for fair treatment can be secured from all sources. By having officers of good judgment backed solidly by every exhibitor member, a favorable impression can be gained among the people.

Sometimes the exhibitor does not take himself or his association seriously enough. We should consider this business as on a par with any other business in the country. The exhibitor should feel his own responsibilities toward the people and then the people can be made to know that he is a responsible man entitled to consideration.

Let every exhibitor consider all sides of a suggestion before he asks the association to take it up. Be sure that it will benefit all and then he has a right to expect every member to back it.

Lastly, every exhibitor should consider the association as a branch of his own business, and give it the same attention

that he would give any department. The association is the exhibitor's bank for the supply of energy and life to the motion picture business. He should expect to deposit as well as to draw and he should give it the dignity he gives the bank that keeps his checking account.

Yours truly,

JAMES GILOSKY,

Treasurer, Twin City Amusement Co.,
St. Paul, Minn.

Join Your State League!

THE MOTION PICTURE EXHIBITORS LEAGUE OF AMERICA

Oklahoma State Branch

Muskogee, Okla., Dec. 6.

Editor, MOTION PICTURE NEWS,
New York City.

Dear Sir: Will you kindly publish the attached communication, which is self-explanatory?

Thanking you in advance, I am with best wishes,

Yours truly,

L. W. BROPHY,

Sec. M. P. E. L. of A.

Oklahoma Exhibitors: It is to be hoped that you paid your War Tax promptly within the time prescribed, otherwise you will have a penalty of fifty per cent. added. Uncle Sam never does things by halves, and in this instance, he has no intention of overlooking anyone.

When it became necessary to raise the War Tax, Congress at once decided that theatre proprietors should contribute liberally. The first declaration was that all theatres, large and small, throughout the United States should pay \$100, this amount was finally reduced to a minimum of \$25, graduating from that to \$100, according to seating capacity for each theatre.

The Motion Picture Exhibitors' League of America, through our president, Mr. Pearce, Fulton Brylawski and others, worked untiringly with the Congressional Committee, and were finally successful in having the tax reduced.

It looks as though this one act would be sufficient recommendation that every exhibitor in the United States would be desirous of having his name placed on the roles of an organization that is continually working for the betterment of the Motion Picture Industry.

Remember, there is not only National Legislation, but State Legislation that is continually being projected by persons

who are not financially interested in the business. The following, which I clipped from the Daily Oklahoman of this date, is self-explanatory:

"An Oklahoma State School Superintendent, R. H. Wilson, makes a recommendation to new Governor and Legislature that a more rigid censorship be required of all moving picture shows which school children are permitted to see, and that nothing of a licentious or outlawry nature shall be shown before children of a school age."

The moral is, "Join the Oklahoma State League." Do not shift responsibility. If you cannot look after your own interests, contribute your mite in dues to some one that will.

L. W. BROPHY, Secretary.

Enjoys the "News" More Than the Daily Papers

ROYAL THEATRE,
Cannelton, Ind.

Editor, MOTION PICTURE NEWS,
New York City.

Dear Sir: Your letter of today, asking if I read the NEWS you are giving. You are "dog gone right" I am. Excuse the expression, but I do look for its coming as eagerly as I do for a good night's show. I enjoy reading it much more than the daily newspapers.

I want to extend my thanks for this favor. I will assure you that I appreciate the NEWS.

Why, the school children beg to get the old copies when I get through with them.

Thanking you again, I am respectfully,

J. S. GERBER.

A Decided Hit

77 Bank St., Lebanon, N. H.

Editor, MOTION PICTURE NEWS,
New York City.

Dear Sir: I have thought for some time that I should write a line to give your very valuable magazine a boost, as I consider it equal to any picture magazine I ever had, and I think I know most of those in publication, as I have been a subscriber to them in the past. Your good book reached me in the way of a "sample copy." Once I read it. It was a decided hit. You will have my subscription for a year. It is just right, splendid descriptions, and all anyone could ask for.

I want to thank you again for your kind favors and beg to remain,

Yours very truly,

R. W. JERLYN.

LARKIN LEAVES UNIVERSAL FOR BALBOA

Special to MOTION PICTURE NEWS

Los Angeles, Dec. 14.

George Larkin, hero of the "Trey o' Hearts" serial from the story by Louis Joseph Vance, has left the Universal Gold Seal company, and is now playing leads for the Balboa Amusement Producing Company. This week he is appearing in his first Balboa release, playing the role of the idle son of the rich, in which he wears but twelve different business suits, two flannel suits, afternoon, evening clothes, and then some others. The title for this is "The Broken Promise," in which Ann Drew and Edna Mayo play the parts of sisters, both in love with the handsome young man of unlimited wealth. The picture will consist of three reels. Wednesday evening, at the request of Manager Burns, of the Butterfly



GEORGE LARKIN

theatre, 16th and Oak streets, Mr. Larkin appeared at the theatre, following the showing of the ninth instalment of the "Trey o' Hearts," in which Larkin jumped from the cross-bar of a mast into the ocean, and for fifteen minutes told the patrons of the thrills he experienced in making the series.

HEDLEY SMITH ON TOUR OF CANADIAN TERRITORY

Hedley Smith, vice-president of the Pathe Freres, is on a visit to Canada in the interest of his firm. Interviewed while in Montreal he stated that Pathe Freres has found Canada to be a large and important field, and as the company has decided to enter it to the fullest extent there will be more Pathe Freres branches in Canada than before.

Mr. Smith further states that these are busy days for the moving picture operators, and more than ever before have been at work throughout the battlefields of Europe.

"Our company has been particularly keen in this work," he said. "Our men have been sent everywhere, and some of them have not yet been heard from. They may have fallen victims of war or may have been imprisoned."

Daly Brings Artistry to Pathe Serial

Shaw Innovator Will Have in "The Exploits of Elaine" a Vehicle Allowing the Star Free Range to His Particular Talent

ARNOLD DALY, who through his work in "Candida" became in such a short time one of the most talked of actors in America, has signed with Pathe to take the leading part in the new serial "The Exploits of Elaine."



ARNOLD DALY

That Mr. Daly stands in the front rank of the theatrical profession today is self-evident, and that he has been signed by Pathe for the new serial proves conclusively that "The Exploits of Elaine" will be a vastly different proposition from "The Perils of Pauline" in that the new story will require most artistic interpretation, and not depend so much upon sensational incidents for its interests.

Mr. Daly is an object lesson to the ambitious young American by proving that there is plenty of room at the top and that ability will be recognized in spite of all handicaps. Some ten years ago he was office boy for Charles Frohman, surely a sufficiently humble beginning in the theatrical profession to satisfy the most ardent admirer of such works of fiction as "From Cabinboy to President."

Born in New York, he showed the average New York boy's sublime indifference to the favorites of fame, and they still tell stories along Broadway of young Daly's scornful attitude towards the famous playwrights and theatrical stars who called upon Mr. Frohman.

At an early age Mr. Daly was convinced that he could act and eventually prevailed upon Mr. Frohman to give him a chance in a small role. He soon showed that he possessed an intuitive dramatic sense and his rise was steady. He was fortunate to have a part in "Pudd'n Head Wilson" under Frank Mayo, whose splendid experience and fine talent gave him much invaluable knowledge.

After that engagement he played the boy in Wm. Gillette's farce "Because She Loved His So," which was followed by the part of the mad lover in "Barbara Frietchie" with Julia Marlowe. Engagements in

"When We Were Twenty-one," "Hearts Aflame," and "The Girl from Dixie" followed. All this time Mr. Daly's art had been broadening and taking on a finer quality. Unconsciously and gradually he had been fitting himself for his great success "Candida."

It is interesting to note that this production, which afterwards played 132 days in New York, was first put on for matinees only by Mr. Daly to demonstrate "a worthy play which could not be commercially successful in New York." Shortly afterwards against all advice, Mr. Daly needing a play as a stop gap, determined to try "Candida" on the New York public. It was done, and each day saw a growth in the receipts. Before long it was the most talked of play in the city, and Mr. Daly was famous.

"THE LAST CHAPTER" NEXT ALLIANCE RELEASE

The next release upon the Alliance Programme, in which Carlyle Blackwell and Ruth Hartman appear, will be "The Last Chapter," taken from Richard Harding Davis' famous novelette, "The Unfinished Story."

The film, which is in five parts and will



CARLYLE BLACKWELL IN "THE LAST CHAPTER" (Favorite Players)

be released December 21, narrates the romantic adventures of an African explorer whose exploits in the jungle are vividly portrayed on the screen. The theme is handled by Mr. Davis in his usual effective manner.

AMONG THE EXCHANGES

ALLIANCE EXCHANGES REPORT INCREASING BUSINESS

THE past week has been a banner one for all of the Alliance exchanges. The reports received by George T. Ames, head of the sales department, show that the volume of business being done by this firm is increasing in all parts of the country with great rapidity. M. F. Tobias, president of the All Theatres Film and Accessory Company, says that his concern, which controls the booking rights to the Alliance program in New York State and City, finds the Alliance features the best money-getters on his list.

"In New York City," remarked Mr. Tobias, "where competition among exchanges is the keenest of any place in the country, the Alliance has been most successful. There are but a few of the high class photoplay houses in the city that are not regular users of the Alliance program."

CAMPBELL WILL MANAGE BOX OFFICE IN BOSTON

HARRY F. CAMPBELL, formerly assistant manager of the New England Universal Film Exchange and manager of Warner's Features, has been prevailed upon after much effort to accept the management of the New England branch of Fox's Box Office Attraction Company on Piedmont street, Boston.

Louis Levine, who has been acting manager, will remain as assistant manager.

WARNER'S INDIANAPOLIS, MOVES

WARNER'S FEATURES, INC., or United Film Service, Indianapolis, has moved from the Lemcke building to 135½ North Illinois street, in the Lyric theatre building.

ALCO STARTS EXCHANGE REPORT SYSTEM

THROUGH the medium of a new and original arrangement instituted this week by Walter Hoff Seely, of the Alco Film Corporation, the parent office of that concern is being kept in close touch with conditions throughout the entire United States, from coast to coast.

A large, double page report sheet, printed on both sides and captioned "Weekly condition report" has been furnished the various exchange managers, with orders to fill out accurately each week and forward to home office so as to reach there by first mail.

The report sheets bear lines calling for reports on the following conditions:

Number of bankruptcies in your district;

LOS ANGELES EXCHANGE MEN UNITE

THREE meetings have been held in Los Angeles, attended by all film exchange men, for the information of an organization of a protective nature, beneficial to the exhibitor as well as the exchange, and within the next few days steps will be taken toward securing a charter or incorporation papers. There will be no capitalization and no stockholders, but instead memberships will be issued to employees of recognized substantial exchanges and dues will be assessed.

The first of the meetings was held early last week, at which time a temporary organization was made, and after a discussion of the plan it was decided to have R. E. Stebbins, manager of the San Francisco Film Exchange Board of Trade, organized about two months ago, come here, meet with the exchange men and assist them in forming an organization.

The San Francisco manager accepted the invitation and spent several days here, during which time he went over the constitution, by-laws and all regulations of the organization now perfected, and which has been in operation for the past thirty days to the benefit of both exhibitors and exchange men.

Primarily the Los Angeles exchange men propose to adopt a credit system which will be protective for the exhibitor and the renters, against the fly-by-night exhibitors and junk film concerns.

There will be regulation relative to credit, so that it will not be possible for an exhibitor to go from one exchange to another as fast as he wears out his credit, and by thus doing secure a number of weeks' service and dead-beat the exchanges for all of it. Attention will also be given to exhibitors who employ incompetent operators or permit the use of

a machine which injures the film more than ordinary wear and tear.

Further than this it is proposed that a standard rate for lithographs be established between the exchange men either for leasing or selling lithographs, as well as photographs and lobby displays of all kinds.

Los Angeles exchanges are to a more or less extent affiliated with the exchanges of San Francisco, and it is very probable that the organization here will be very similar to the one at the northern city.

BARGMAN TO MANAGE GOLDEN GATE, LOS ANGELES

TED L. BARGMAN has been appointed manager of the Golden Gate Film Exchange, at Los Angeles, a branch of the film renting institution of which Sol Lesser, of San Francisco, is president, and which has exchanges in many of the principal Western cities. Mr. Bargman has been connected with the company for the past six months in the capacity of salesman, and has made an enviable record during that period of time.

EDWARDS-ZETLER TO HAVE CINCINNATI BRANCH?

WORD is going through real estate circles in Cincinnati that the Edwards-Zetler Feature Film Company will in the near future open a branch agency in this city. The company has branches all over the country, and its Cincinnati branch is slated to occupy space in the Savoy Hotel Building, on East Sixth street. The lease is said to have been made through the firm of Cleaney, Nourse and Huntington.

UNIVERSALS IN GREAT DEMAND AT WASHINGTON

S. J. MAYER, formerly of the General Film Company, is now at the head of the Universal forces at the Washington Film Exchange. Mr. Lavelle, the former manager, remains there as assistant. Mr. Mayer reports everything prosperous "Universally," with "The Master Key" much in demand.

TRI-STATE TAKES KRITERION

THE Greater Tri-State Feature Film Company of New York has closed with the Mica Film Corporation to handle all their releases under the Kriterion program. David Kren concluded this arrangement, whereby all the eastern district will be handled by them.



VIA KRITERION ROUTE

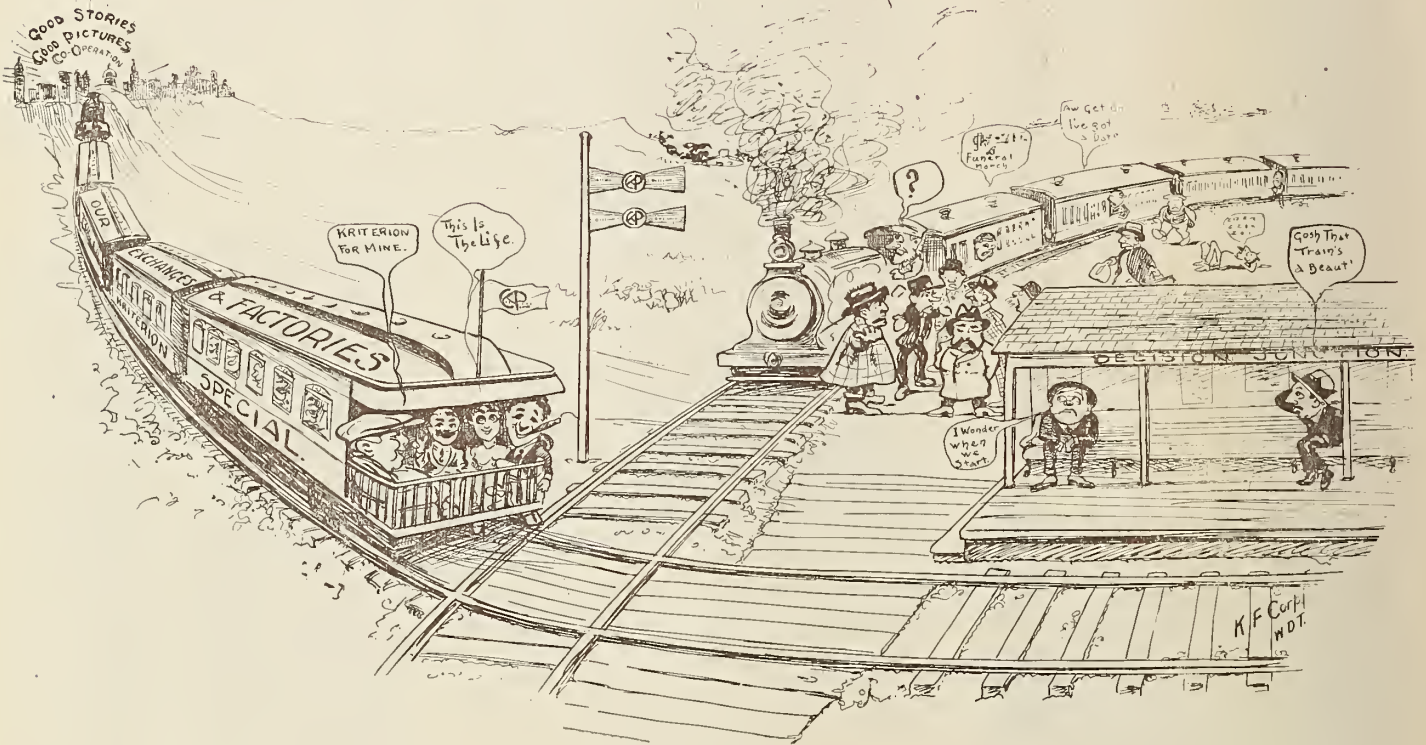

This is the first section of the Kriterion Special going through on a clear track and headed in the right direction. It is just crowded to capacity with those people who have been convinced. Are you on it? But don't answer—here is a secret—there is a second section of this train following right behind and this train is going to stop at "Decision Junction." Hop on! You will have plenty of company. Why travel on a local when it is just as inexpensive to travel on an express. And you get there **SO** much quicker.

You have been held up at this Junction long enough. You know you have been waiting for this very train. Now don't stop to buy tickets, just drop in the station and we will give you a pass to take you to "Co-operative land" where everything is teeming with good stories and good photography.

Don't Hesitate—Act NOW

KRITERION SERVICE

(Mica Film Corporation)

Sixth Floor

1600 BROADWAY

NEW YORK CITY





CONFIDENTIAL CHAT

Do you believe that the film field is already crowded with — —? We know you do, but there is **something lacking**. We have become convinced that the public is educated in the matter of **stories, photography and acting** in films. They are **absolute critics** in this matter and demand of the manufacturer that he produce quality in each of these subjects. They have passed the novice stage and will go where this kind of film is shown regardless of program.

A man goes home from his day's work, eats his dinner, reads his paper and then wishes to take his family to a theatre. Does he wish to go scouting all around the town gazing at the lithos and posters in the lobbies of the show houses to see which one he wishes to go into? He is too tired for that. He wants to know when he leaves home where he is going and that, if he goes to So and So Theatre, he will at least see a good set of films and be pleased.

The public is tired of being pumped by advertising to go and see a well known "star" and then when they see the picture they find they have seen nothing but the picture of the "star" minus a story and good photography. On the other hand they hear that a well known book is being pictured. They go to see it and find that the photography is poor, acting is poor and the story has gone to waste.

How will we remedy this? We will do it this way. By putting on a film service of good stories, good photography and these combined with co-operation with the Exhibitor spell quality and success. Each one, essential and the whole lost when one is left out.

**THE PUBLIC DEMANDS THIS
WE MUST GIVE IT TO THEM**

You cannot imagine a manufacturer sending reels of film to his exchanges and Exhibitors for their favor and the film being the first test prints and minus main and sub-titles. Well, that is just what we did. We showed them the goods in the embryo state, undressed and un-trimmed, and they enthused over the program. What will they do when they see the finished article? Get in touch with us at once and let us show you our film.

**You are the ultimate Judge and Jury.
Let us convince you.**

LOOK OUR TALENT OVER

A. M. Kennedy
"Bob" Daly
Fritzi Brunette
Bert Angeles
Donald MacDonald
Dorothy Davenport
John Dillon
Edward Alexander
Helen K. French
Craufurd Kent
Frank Montgomery
Justina Wayne
Charles K. French
Wallace MacDonald
Mary Ruby
Jack Prescott
Harry Fisher
Mona Darkfeather
Sidney DeGray
Benj. Horning

Lee Hill
"Bud" Rose
Lucille Young
Wm. E. Parsons
J. L. Phipps
Katherine Sheldon
Allen Fralick
Will. Cowper
Rena Rogers
Tom. Ward
Henry Travers
Eva Lewis
Harry Davenport
Chester Whitey
Albert Kerry
Theodore Roberts
Bruce Mitchell
Anthony W. Coldewey
Alex. Frank
Harris Forbes

K R I T E R I O N S E R V I C E

(Mica Film Corporation)

Sixth Floor

1600 BROADWAY

NEW YORK CITY



"THE TRUTH WAGON"

(Masterpiece-Alliance—Five Reels)

REVIEWED BY J. C. JESSEN

MAX FIGMAN was seen on the screen of the Butterfly Theatre, Monday evening, playing the part of John Ross, the Little Joker, which he created for the original New York presentation of the Hayden Talbot play, "The Truth Wagon," when the second Masterpiece Film Manufacturing Company's production for the Alliance program was given its first screen examination in Los Angeles by members of the company, guests, exchange men and exhibitors. The release date for this subject is, at the present time, fixed for December 14.

This play, founded on "the sober truth," to use the words of the author, a newspaper man, deals with political conditions, the bridling of the public press, and takes for its leading character a son of the rich, who through his early life wastes away his time and his father's money in playing practical jokes on his friends.

His last act of this kind was to "kidnap" all the men from a social function given by his family and take them to a barge where he staged an amateur prize fight. The jests of his friends of "Why don't you tell the truth and go to work" induce the young man to buy a fast dying newspaper, *The Truth*, which will not lie, from William Dean, father of Helen, a newspaper woman.

Under the management of Young Ross, *The Truth* exposes political intrigues, causes his father to resign from the gubernatorial candidacy, elects the former editor of the paper, lands a knock-out on the political ring that has controlled the state, and wins for the "Little Joker" the hand of the daughter of the governor-elect, Helen Dean.

The production was filmed under the personal direction of Mr. Figman, who appears at his best as the dashing, quick-witted and impulsive young millionaire, who makes a winning fight against odds which include the members of his own family, his circle of friends and the powerful ring of politicians. Al W. Filson appears



A LULL IN THE OFFICE OF "THE TRUTH"

as Francis Sullivan, the ward healer, and H. A. Livingston as Forbes, the double-dealing reporter addicted to the morphine habit.

Lolita Robertson impersonates the role of Helen Dean—which she played in the original stage production—the guiding hand at the steering wheel of the vehicle of truth on its trip over rough journalistic roads. The scenario was prepared by Elliott J. Clawson and photography was in charge of George Rizard.

"THE MASTER KEY"

(Universal Special—Fifth Episode)

REVIEWED BY PETER MILNE

WHILE nothing in the way of sensational thrills, or risk of life is present in this, the fifth episode of "The Master Key," the story advances over a considerably large space, growing, so it seems to the observer, more tense and more engaging as each foot clicks its way through the machine.

The scene of action is shifted, for the time being, from the

Master Key mine to the Chinese quarter of San Francisco. There is always something unusually horrible and mysterious about a story which is laid in the Chinese quarter of any great city, so when Ruth Gallon, the heroine of this story, is imprisoned in a Chinese den, the greatest anxiety for her safety is evidenced.

John Fleming Wilson has developed the story to a great extent in dramatic force and intensity, so that even though there are no hair-raising feats accomplished or performed by the principals of the story, the interest of the spectator is always held at its height throughout these two reels.

It will be remembered that in the preceding episode Ruth fell



RUTH IS TAKEN TO THE CHINAMAN'S DEN

into the hands of Mme. Darnell and Crane, parties working in cooperation with Wilkerson. In the first reel of this chapter Ruth discovers that these people are not her friends, as they professed to be, but in reality her worst enemies.

She attempts to escape from the hotel where they are holding her prisoner, but is unsuccessful. So, taking no risks, Wilkerson takes her to Chinatown, putting her in the care of a former partner in some sort of crime.

By this time, however, Dore has come to the city and learns that foul play is the order of the occasion. He happens to take the same room in the hotel which Ruth occupied, and in the drawer of the bureau he discovers the deeds of the mine. These the conspirators are searching for, and when they do not find them in Ruth's satchel they are furious.

The photography and scenes of these two reels deserve a very good word. The film is tinted appropriately and all the scenes are photographed with decided clearness. The exteriors of the Chinatown scenes are of course realistic, and the interiors are deserving of the same praise.

FOUR GRACEFUL DANCERS AT EXHIBITORS' BALL

FILM stars were not alone in dazzling the dancers at the exhibitors' ball at the Grand Central Palace. The purely commercial feature of the industry was represented by young women who would be anything but a discredit to the screen.

For instance, one can well imagine Joseph A. McKinney, general manager of the United Film Service, trembling with apprehension lest such valuable office allies of the company as the Misses Feinman, Fried, Janover and Horwitz (two of them) should desert their revolving chairs for the revolving film.

All of these young women were present at the ball and were the center of much admiration.

WAR TAX CLOSES SMALL KENTUCKY THEATRES

Special to MOTION PICTURE NEWS

Lexington, Ky., Dec. 15.

OWING to the new war tax, which became effective December 1, one of the two moving picture shows in Hazard, Ky., in the mountain county of Perry, 110 miles east of Lexington, has closed indefinitely. The same is true of several other film houses in the smaller mountain towns, where small patronage will not admit of the increased strain on the profits.

"THE CRUCIBLE"

(Famous Players-Paramount—Five Reels)

REVIEWED BY PETER MILNE

AN unusually large number of players from the legitimate stage have been recruited for the screen of late by many of the picture producing companies. Famous Players have obtained the services of a select majority of these stars, but most of them merely come and go with long intervals between, though leaving, it is true, a memorable impression.

But with the case of Marguerite Clark it is different. She has already appeared in one screen offering, "Wildflower," totally different from "The Crucible," and although it was not our pleasure to see it, judging from her performance rendered in the latter play she is still far from being forgotten. The fact that she has been retained by the Famous Players is illustrative of a wise and happy move on their part.



JEAN SCORES A SOCIAL TRIUMPH

Less accomplished actresses than Miss Clark might have lost themselves in the rather sad and slightly gruesome story which, at times, "The Crucible" presents. As she interprets the principal part, its pathos, its charm, its goodness and its simplicity are almost equally predominant.

Hardly any phrase could be more expressive of Miss Clark's characterization of Jean Fanshaw than to say it teaches its watchers that to return good for evil results in happiness.

"The Crucible," a novel written by Mark Lee Luther, may be accounted by some, slightly exaggerated in its first phases, but, as the story progresses, it becomes more and more convincing. Some, too, may question the possibility of a girl escaping from a reformatory and successfully eluding her pursuers, but, strange as it may seem, as pictured and as acted it seems quite probable. In other words, wherever the story departs from consistency, the ability of the players is great enough to counterbalance the slight faults in the plot.

Jean, the role which Miss Clark so successfully carries, is the abused younger daughter of a widowed mother. In a petty quarrel with her haughty and insolent sister, she accidentally cuts her with a sickle, and, on Amelia's terrible accusation of attempting to kill her, Jean is sentenced to a year in the reformatory.

Thereafter Jean is forced to struggle against innumerable evils, from all of which she emerges triumphant. She aids her sister, causes her husband to return to her, and at length is rewarded by finding happiness and love with an artist for whom she once posed.

Of the rest of the cast Helen Hall and Harold Lockwood are on a par for honors. The former, in her rendition of the part of Stella, a periodical habitue of the reformatory, is truly characteristic, and the latter as Craig, the artist, is as good as usual. Justina Johnstone as Amelia has rather a weak part, but makes the most of it. Lucy Parker appears as the mother of the girls, and Barbara Winthrop as the society bud.

The settings are appropriate and elaborate when the occasion permits. The scenes are well chosen, some of them being most beautiful. The photography in the print shown is rather dim in some scenes, but is on the average good and distinct throughout.

"AS A MAN SOWS"

(Aquila-Sawyer—Five Reels)

REVIEWED BY H. S. FULD

THE producers of this film have gone to rather greater lengths than the average, in that they have spared no pains on the interior settings. The scenes representing the banking offices, the living rooms of the principals and the carnival and fête depictions are masterpieces of their respective representations.

The photography and tinting of the film help to accentuate this creditable performance and the scenes are brought forward with a clearness and distinctness that should go far to add to the producer's reputation. There are five reels of rather elaborate melodrama—elaborate in that although the story is one of the familiar type of embezzling bank-cashier, the company has taken many liberties and made three complete stories out of the one, but intermingled them so as to make one grand ensemble, as it were, and the result is an interesting conception in its entirety.

There is the story of the watchman's daughter Iris, who, after her father is killed by the escaping cashier, goes on the stage and becomes famous. There is the story of the cashier's son who, twenty years later, after many trials, meets Iris and finally marries her. And then the story of the cashier, after twenty years, now a master crook, who almost killed his own wife; and the son, who, on account of his wonderful likeness to his reprobate father, is accused of the crime. Then all three stories come to a head, the villain is killed—hoisted on his own petard, the young couple are united, the wife recovers, and everybody is happy.

There is one scene or rather a series of scenes that stands out above the others. The fête scenes, close-ups and ensemble are beautiful examples of what a competent director can do with a cast of young dancing girls and good lighting effects and a master camera-man. The girls, and there are twenty of them, would seem to have been chosen, not alone for their excellence as to form and beauty, but for their graceful dancing as well.

The scenes that go to make up this fête or carnival are not alone splendidly photographed, but the tinting of the different scenes especially those of the dancing girls, is nothing less than a work of art.



TAKING HIS FAREWELL

Such blending of different colors as one would see on a spectacular production on a stage with the aid of colored spotlights, is here depicted on the screen. From red to yellow, to green, to red again, to orange and so on, the changes are so gradual as to appear as though consummated with the aid of spotlights. And yet it is only the tinting of the film.

The dancing also is good, and what is rarely seen on a scene of this kind, the dancers keep perfect time, and are personifications of grace.

Of the story itself, it is all absorbing in itself, and will hold the observer interested throughout. The acting of the principals is on the whole excellent, save for the minor fault—if it is a fault—of Iris's tendency to voluptuousness when she is supposed to be depicting strong emotion.

"YOUNG MRS. WINTHROP"

(Edison—Two Reels)

REVIEWED BY CLIFFORD H. PANGBURN

BASED on Bronson Howard's play of the same name, "Young Mrs. Winthrop" is a picture of more than usual dramatic excellence and force. The problem which it presents, that of an estranged mother and father reconciled through a little child, is not a new one, but the treatment and the sympathetic acting make an offering of much merit.

Mabel Trunelle as the wife and Gladys Hulette as her blind sister-in-law handle their parts with especial success. Miss Hulette carries off her difficult role with surprising realism and yet with no tendency to offend the finest sensibilities.

The general arrangement and setting of the picture call for comment. Nothing elaborate is required by the story, but on the other hand, carelessly arranged scenes would do much to soil the



WINTHROP REALIZES HIS FOLLY

effect of the narrative. That these have been avoided entirely speaks well for the producers.

A young husband who is intensely devoted to his wife is kept rather busy by a rush of work. He has to see a woman about a business matter but she arranges to have him come to her home one evening, and to avoid a tiresome explanation to his wife, the husband goes there secretly.

This, together with several other incidents, leads to an estrangement, which is ended at the bedside of their child when she becomes dangerously ill. There is an under plot concerning the husband's blind sister and the wife's brother. Altogether a most satisfactory picture.

FOX ANNOUNCES THREE MORE FEATURES

WILLIAM FOX, president of The Box Office Attraction Company, has announced three more big "productions extraordinary," which are included in his series of fifty releases of big stage hits.

"The Gilded Fool," by Henry Guy Carlton, was produced at Miner's Fifth Avenue theatre by Nat Goodwin. Mr. Goodwin starred in this play.

"The Butterfly on the Wheel," by Francis Neilson and Edward G. Hemmerde, was produced by the Shuberts in January, 1912, at the 39th Street theatre, with Madge Titheradge and Louis Waller. This is a story of scandal in English society where the wife becomes involved in a scandalous divorce action.

"The World and His Wife" is by Jose Echegaray, the Spanish dramatist who wrote all the great plays for the Royal theatre, at Madrid. This play was translated by Frederick Nirdlinger, produced by William Faversham and used by him as a starring vehicle for both himself and his wife, Julia Opp.

HANSEL SUCCEEDS LONERGAN

HOWELL HANSEL, director of Thanhouser's famous success, "The Million Dollar Mystery," has been put in charge of productions at the New Rochelle studios, taking the place of Lloyd Lonergan, who recently resigned from that company.

WILL FIGHT POLICE EDICT AGAINST LARGE POSTERS

Special to MOTION PICTURE NEWS

Pittsburg, Pa., Dec. 15.

THERE is soon to be a test case of the law regarding the placing of large posters in the lobbies of the motion picture theatres in this section. A. C. Stein, one of the prominent attorneys in Pittsburg, has taken the matter up and will fight the law to the limit.

A number of the police officials have served notice on the motion picture theatre managers that they are not to put up posters larger than three sheets. This has not met with the ideas of the exhibitors and they are getting ready to fight.

According to a statement of Mr. Stein, there is nothing in the law that gives the censors any jurisdiction over the kind of advertising material used in the lobbies of the theatres, as their work only calls for the pictures shown on the screen.

MARGARITA FISCHER TO ACT IN FOUR-REELER

MARGARITA FISCHER, famous for her beauty and grace, is to be featured in the four reel features on which Harry Pollard has begun work in Santa Barbara. Mr. Pollard will appear in these features when necessary, but he will direct all of them. Among others whom he has engaged for the cast is William Carroll, the noted character man.

The American Company expects shortly to release these features in the Mutual program, and, due to this increased output, President S. S. Hutchinson recently has been a more frequent visitor to Los Angeles and the South. On his last trip to sunlit California Mr. Hutchinson took with him Director Thomas Ricketts who is on the lookout for new talent.

"THE BELOVED ADVENTURER"

(Lubin—Fifteenth Episode)

THIS is the final number of Emmett Campell Hall's fascinating serial and the patrons of the photoplay will be delighted to know that Lord Cecil and the charming little Betty have at last reached the haven of lifelong prosperity and happiness.

Betty always had the idea that socially she was far from being Cecil's equal, and it gave her much anxiety, but by accident she discovers that she was even more, for she learns that she is the grand-daughter of the Duchess of Drex, who is the autocratic leader of society, and a millionaire heiress in her own right into the bargain.

The greatest day in Cecil's life is when on the balcony of the



IN THE POT O' DREAMS

mansion he presents Betty and her baby son, who will be the future Lord of Croftleigh, to the tenantry of his 10,000 acres. Truly Lord Cecil has been an adventurer and much beloved, and the sequel of the story is proof that virtue will reap its reward. Many patrons of photo-motion will be sorry that the tale has ended, but another serial will immediately follow, it is promised by the company.

STEFANSSON AND SOME SCENES FROM THE SUNSET COMPANY'S FILMS DEPICTING HIS ILL-FATED EXPEDITION



SURVIVORS LEAVING THE SECOND CAMP FOR THE RESCUE SHIP

V. THJALMUR STEFANSSON

RESCUE PARTY AT THE FIRST CAMP; CROSS SHOWS GRAVE OF TWO OF THE EXPLORERS

"IN THE LAND OF THE HEAD HUNTERS"

THOSE first nighters who braved the chill winds and rain on Monday evening to witness the first presentation of Edward S. Curtis' Indian epic drama of the Northern Seas, entitled "In the Land of the Head Hunters," were amply repaid for their courage, for it not only proved to be a masterpiece photographically, but is an intensely gripping and thrilling story of primitive life found existing on the shores of the North Pacific by the first exploring party.

No melodrama of the present day could be more vividly interpreted by a Broadway cast than was presented by these savages, for be it known, each character was impersonated by either himself or herself.

Many of the scenes make one's hair stand on end, and there were not a few who are still wondering whether the pictures were posed for or whether these headmen really decapitated their victims during their various battles, so realistic and true to life are they enacted.

The story takes one through a part of the country the splendor of which is almost indescribable. One can hardly believe nature has given so barbaric a race such a beautiful spot for their own.

The interpretive music which is played through the entire picture was composed by John J. Braham from original phonographic records, made by the exploring party. If well warranted and frequent applause is any criterion, the picture should enjoy a long and profitable run.

The films have a great educational value and have no doubt added another page in the history of research made by this well-known explorer.

"LAST CHAPTER" WELL RECEIVED AT PRIVATE SHOWING

Special to MOTION PICTURE NEWS

Los Angeles, Dec. 14.

A PRIVATE showing of "The Last Chapter," the Favorite Players latest release, featuring Carlyle Blackwell, was given here today before a select company of directors, exhibitors and exchangemen. Great enthusiasm was manifested over the photography of the picture, the camp-fire, sunset and silhouette effects. William D. Taylor directed the production, which is to be released through the Alliance program.

Nat A. Wagner, a west coast exchangeman, declared after the showing: "The Last Chapter' is the equal of any and superior to many features released during the last few months. Blackwell's work is immense and Director Taylor should be proud."

NEW STAGE NOW IN USE AT INCEVILLE

ADDITIONAL proof of the ever increasing demand for the productions of the N. Y. M. P. Corp. has been furnished by the fact that a large new extension to the already mammoth stage at the Inceville studios has just been constructed.

The stage now measures some 200 feet in length and 75 feet in width. There is ample space for the staging of a dozen different scenes simultaneously, while the entire area can be used to produce one of the biggest single sets possible in motion pictures today.

24 FREIGHT CARS FOR "ZUDORA" EPISODE

TWO freight trains of twelve cars each will be used in a scene in "Zudora," the Thanhouser's serial. The action requires both trains to be running at top speed, when James Cruze climbs over a car on one train, releases a lever, and cuts the train in half. In one of the cars is Marguerite Snow and Helen Badgley, who are rescued by Cruze just as the car is sent skyward by an explosion.

The cost of this one scene will be \$5,000. Another setting of unusual gorgeousness will be seen in the eighth episode of "Zudora" when Elizabeth Forbes, recently added to the cast, will make her first appearance.

The set cost \$11,000 to build and it is fitted with more than \$30,000 in antiques. A special insurance policy had to be taken out to cover the property during its use in the picture, as the entire collection has been sold to a European woman who has had her cast collection destroyed when her home in Belgium was burned during the recent fighting before Antwerp.

A special train will carry the Thanhouser actors to a point on Long Island where the train scene will be taken. In the party will be Director Frederic Sullivan, Marguerite Snow, James Cruze, Harry Benham, Elizabeth Forbes, Helen Badgley and fifty other persons, besides Cameraman George Weber and Assistant Director Al Mayo. The railroad company will have two trains waiting in addition to a complete wrecking outfit which must clear away the wreckage immediately so that the regular traffic on the road will not meet with interference.

BOSWORTH MOVES NEW YORK OFFICES

IN order to be in the heart of the film district, the New York headquarters of Bosworth, Inc., have been moved uptown and a suite of offices have been taken over on the eighteenth floor of the Candler Building, at 220 West 42d street. Installation of the furnishings is now nearing completion and it is expected that by the time Special Representative Carl H. Pierce returns to New York the offices will be fully equipped and in smooth running order.

Mr. Pierce is now finishing up a tour of the Bosworth exchanges and will be back in town the latter part of this week, when he will take active charge of the new offices. During the absence of Mr. Pierce the New York headquarters will be under the management of Julian M. Solomon, Jr.

NEXT COSMOS FILM RELEASED JANUARY 11

THE Cosmos Feature Film Corporation have decided to release "The Little Girl That He Forgot," with Bculah Poynter in the title role, on Monday, January 11. The setting is in a lumber camp in the swamp lands of Missouri. The action is replete with heart interest, beautiful scenic effects, acting and photography. Miss Poynter, who plays the title role, toured the country for four years in the dramatic version of this photoplay and has novelized the same. The novel will be ready for publication about the same time that the feature is released. In addition to the above, the Cosmos Feature Film Corporation have planned an extensive and expensive publicity campaign.

EDWARD ABELES IN SAVAGE'S "THE MILLION"

The Famous Players will end the old year by releasing Edward Abeles in a film version of Henry W. Savage's successful farce production, "The Million," on the very last day of 1914. This famous melodramatic farce has won the distinction of possessing more laughter and wholesome fun than any comedy of recent years. If the old philosophers are right, and "laughter is wealth," then "The Million" is well named.

The subject also presents one of the most remarkable examples of character acting supplied in many years, in the impersonation of "Le Baron," the crook, by Edward Abeles. In the course of the story he is called upon to portray no less than six entirely distinct characters.

POWER'S CAMERAGRAPHS AT SAFETY EXPOSITION

The Nicholas Power Company, manufacturers of Power's Cameragraph projection machines, will have a booth at the Second International Exposition of Sanitation and Safety, to be held at the Grand Central Palace, New York City, from December 12 to 19, inclusive. The Power company will demonstrate the safety appliances of their machines in a specially constructed theatre on the third floor, where the current releases of the various film companies will be shown from 2 p. m. until 10:30 p. m. each day. Power's will have booth 36.

CASTLE WILL BE EDISON COMEDY DIRECTOR

A new director for the Edison Company is James W. Castle, who will direct the company's comedies. Mr. Castle brings with him all the wealth of successful experience gathered in his rise from call boy many years ago to the position of owner of well-known stage productions. He has been director for Madame Schuman-Heink, noted musical comedy successes, and has had such stage stars under him as Marie Cahill, Raymond Hitchcock, William T. Carlton and Adele Ritchie.

SMALLWOOD WILL SEND COM- PANY TO LOS ANGELES

The Smallwood Film Corporation, producers of Grandin films, in the United Film Service, will within a few days send a company to Los Angeles for the winter months.

Ray C. Smallwood, Ethel Grandin and John Brownell among others will make the trip to California. Arrangements have already been made for a studio where the company will make two reel comedy dramas featuring Miss Grandin.

GRAND, CANTON, GOES TO FILMS

Special to MOTION PICTURE NEWS

Canton, O., Dec. 15. The Grand theatre, operated here under lease by Feiber & Shea, of New York, will shortly abandon spoken drama, as reproduced by a stock company known as the Canton Players, and show motion pictures exclusively, it is announced.

Alec Lorimore Active in Two Companies

President of National Movement Motion Picture Bureau, Inc., and Bishop, Pessers & Lorimore, Inc., Plans Important Move in Film Circles

INTERVIEWED at his new office in the Longacre building, Alec Lorimore expressed himself as fully satisfied with the progress being made by the National Movement Motion Picture Bureau, Inc., and Bishop, Pessers and Lorimore, Inc.

With regard to these companies, of which he is president, he expected to be able shortly to announce successful moves of

The main purpose of this company will be to act as a foreign clearing house for American productions. Through the already strong organization of Bishop Pessers and Co. Ltd., of London, the new company is in a position to obtain the best possible results for American productions in Great Britain, her colonies, South America and Japan, and in addition will handle



WILLIAM C. HILL

EDNA WILLIAMS

HENRY PESSERS

ALEC LORRIMORE

an important nature, but preferred to be silent on such matters for the present.

In the case of Bishop, Pessers and Lorimore, Inc., he has the active support of Henry Pessers and Edna Williams, and in London the support of Stanley W. Bishop, who is well known in New York film circles. Mr. Pessers has had a very successful record in the film business, and his experience covers most European countries. He is a man of modest bearing, but a keen student of human nature, and a tactful, resourceful, reliable business man.

Miss Williams has long been connected with the theatrical world, and is well known to the heads of many film houses on account of her heavy purchases for Australia and South America. She will act as secretary of the company.

in America such features as they receive through their London office.

In the National Movement Motion Picture Bureau, Inc., Mr. Lorimore will also have the support of Mr. Pessers, and in addition Wm. C. Hill.

Mr. Hill is a newcomer in the amusement field. He was the organizer and late president of the Pyrene Fire Extinguisher Company, is a university man, and well known in commercial and financial lines.

Mr. Lorimore has the necessary ability to make a success of these companies. He is genial, diplomatic and forceful, but above these assets he has the well deserved reputation of always making his word good, once he has given it. There is room in every field of human endeavor for men of this class.

Pennsylvania League Ball Draws Big Crowds

Horticultural Hall, Philadelphia, Is Packed with Representatives of All Branches of the Film Industry—Laemmle and Lubin Fraternalize Together

Special to MOTION PICTURE NEWS

Philadelphia, Dec. 15. DESPITE the inclement weather which prevailed, a big crowd turned out to help make the annual ball of the Motion Picture Exhibitors' League of Pennsylvania the most successful one in its career. With an orchestra of sixty pieces to furnish music for the dancing, the Horticultural Hall was packed by ten o'clock with joyous fans, exhibitors and photoplay celebrities.

Romaine Fielding, Lubin actor-director-author, and Ormi Hawley, also a Lubin star, were prominent among the latter in that they were guests of the league and led the grand march. Miss Hawley and Mr. Fielding, with others, among whom were Clara Kimble Young, Edwin August, Edgar Jones, Lottie Briscoe, Francis X. Bushman, Beverly Bayne, Edmund Breeze, Siegmund Lubin and Carl Laemmle, were introduced from the stand just prior to the march, which took place at twelve o'clock. Miss Hawley wore throughout the even-

ing a handsome bouquet of American beauty roses, presented to her by Mr. Fielding as she came upon the floor. During the course of the night's dancing a beautiful colored drawing of Miss Young was put up at auction, the proceeds of which were to be handed over to the Belgium relief fund. The drawing went to Siegmund Lubin and Carl Laemmle, who joined together in the bidding.

An event of the evening which proved of human interest worth to those who were witnesses, was the meeting between Mr. Fielding and Edmund Breeze, famous legitimate star. Fourteen years had elapsed since the paths of these two artists crossed; prior to that, when Mr. Fielding was also doing the legitimate, the two men had been fast friends. At the finish of the dancing, Mr. Breeze accompanied Mr. Fielding to his apartments where the rest of the night was spent in going over old times and discussing the picture business as it is developing.

INTERESTING FILM REVIEWS

PRODUCTIONS FROM ALL PROGRAMS

GENERAL FILM PROGRAM

"Their Cheap Vacation." (Essanay. Mon., December 21).—Wallace Beery and Betty Brown appear in this amusing comedy dealing with a ludicrous misfortune of the Newlyweds on an "ideal" automobile trip, which is to cost them \$12. It not only costs them far more than this amount, but they have a miserable time and decide never to economize in this manner again.

"Arthur Truman's Ward." (Vitagraph. Mon., December 21).—When a girl of wealth is on her way to her newly appointed guardian's home she is hurt so that she loses her mind. Finding her papers and letters a poor girl goes on and impersonates the injured one. Her supposed guardian falls in love with her, and later when she regrets her act and restores the right girl to her home and property he marries her.

"A Matter of Court." (Biograph. Mon., Dec. 21).—When a lover wrote to his girl that his life was worth only two cents he hardly supposed that this admission would be used against him in a damage suit, but such is the case in this farce comedy. On the same reel with "The Dentist's Janitor."

"The Dentist's Janitor." (Biograph. Mon., Dec. 21).—The janitor tries to make a hit while the dentist is out by impersonating him. Trouble and more trouble is his reward. On the same reel with "A Matter of Court."

"The Adventure of the Wrong Santa Claus." (Edison. Mon., December 21).—One of the adventures of Octavius, the amateur detective. Octavius is dressing to play Santa Claus at a friend's house when he is felled by a burglar, who utilizes the same disguise. Octavius pursues him to the city and finally returns with the stolen presents. Barry O'Moore is featured. A good Christmas comedy.

"The Flower of Faith." (Selig. Two reels. Mon., December 21).—This is the story of three educated and refined people—a girl and two men—who are the only survivors of a shipwreck. Their struggle for existence on the desolate island wears off the social veneer and reveals the true natures of the three. Both men love the girl. In the inevitable fight that follows the less physically efficient succeeds in protecting her from the other. Later when it is discovered that the girl has developed leprosy, the real man decides to remain on the island with her, at the sacrifice of his own life, when a vessel opens the way for their escape. No factor is lacking to make this a thoroughly excellent production, worthy of the best efforts of Kathlyn Williams, Wheeler Oakman and Charles Clary.

"His Suicide." (Lubin. Tues., Dec. 22).—A split reel comedy with "Flossie's Daring Loyalty." A henpecked husband is not even allowed to commit suicide in a peaceful way, but finally blows himself up by drinking gasoline and holding lighted matches near his mouth. The unloving couple are played by Jerold Hevener and Mae Hotely.

"Flossie's Daring Loyalty." (Lubin. Tues., Dec. 22).—An excellent hurlesque of the business melodrama. Flossie is true to her employer and her refusal to tell his business secrets almost leads to a terrible fate. On the same reel with "His Suicide."

"On the Heights." (Biograph. Two reels. Tues., Dec. 22).—This is the sixteenth in the series of Biograph productions of well-known novels. "On the Heights" is from the story by the same name by Berthold Auerbach. It is a tale of court life in a small kingdom. A countess who is ordered by the king to wait on the invalid queen finds herself courted by the king when he thinks his wife is dying. The countess is forced into a quarrel with her father by her association with the king. A tragedy is narrowly averted. Gretchen Hartman is seen as the Countess Irma, while the role of the king is taken by Edward Cecil. Alan Hale appears as the countess' lover.

"By the Governor's Order." (Vitagraph. Two reels. Tues., December 22).—The refusal of a tyrannical parent to allow his daughter to marry as she wishes leads to her elopement and death and to a prison term for his son-in-law. The lat-

ter finally escapes and is saved from going back to the penitentiary by a pardon obtained by the repentant old man.

"Olive is Dismissed." (Edison. Tues., Dec. 22).—The fifth of the series known under the title of "Olive's Opportunities." Olive learning that Vance Coleman still wishes to marry her and that her guardian and the bishop advise him against it decides to leave the place, and taking her pet monkey appears on the road again in gypsy costume. She is taken up by a wealthy woman who thinks that she will be an amusing object to exhibit to her society friends. The girl manages during her stay at the house of the wealthy woman to restore the happiness of herself and her husband, although while doing so she gets herself dismissed. Mabel Trunnelle is seen as Olive with the usual supporting cast.

"The Volunteer Burglar." (Essanay. Tues., December 22).—Munsey's Magazine furnishes another interesting story for an excellent cast including Richard C. Travers, Beverly Bayne, Lester Cuneo and Bryant Washburn. The picture shows a young author assisting a beautiful girl in recovering a fortune which some imposters have taken from her. The story is ended upon the typewriter of the author, and it is discovered that all the action took place in his brain.

"Wade Brent Pays." (Selig. Tues., December 22).—A dissolute young man reforms because of his love for a girl who, he afterwards learns, is engaged to another man. In his sorrow he turns to a girl who has loved him and finds that he can return her affection. A light drama, well produced and acted and containing enough action to make it interesting.

"The Lady or the Tigers." (Selig. Wed., Dec. 23).—A drama made thoroughly worth while by the excellent acting of Kathlyn Williams, and the introduction of some well-trained tigers that add real thrills to the picture. The villain attempts to estrange from her lover the beautiful artist whom he has engaged to paint animal pictures at his house. Failing in this, he hurls the lover into a cage of tigers, but the heroine who has learned the art of training these ferocious beasts comes to the rescue in the nick of time.

"The Single Act." (Lubin. Two reels. Wed., Dec. 23).—An interesting although impossible crime story built along conventional lines. It presents the familiar case of a thief who poses as a gentleman, and who is finally killed as he is trying to perform an heroic act which would have justified his existence. Velmas Whitman and George Routh are seen as the crook's sweetheart and the thief, respectively.

"The Professor's Romance." (Vitagraph. Wed., December 23).—A widow moves into the house next door to a professor, and her two children proceed to put a permanent end to the peace which was formerly general in the neighborhood. After many trying experiences the professor finds himself in love with the widow. They are married and the children find that they now have a firm hand to guide them. A good comedy featuring Sidney Drew and Jane Morrow.

"One Traveler Returns." (Selig. Wed., December 23).—A good production with Stella Razeto, Adda Gleason and Lamar Johnstone as principals. On his wedding day the bridegroom's former mistress is killed in a realistic automobile wreck while she is hastening to the church to prevent the marriage. Before she dies she writes a confession to his wife, but her spirit later appears, influences the messenger to destroy the letter, and blesses the happy pair.

"'Twas the Night Before Christmas." (Edison. Wed., December 23).—A split reel fantasy which is sure to be very pleasing to children, and enjoyed by all. It shows Santa Claus at home after his Christmas gift distributing. A little American child travels by magic to many other lands and gathers a group of children of many nationalities. Each takes his favorite toy and, going to Santa Claus' home, gives him two stockingsful of presents. On the same reel with "Buster Brown Causes a Commotion."

"Buster Brown Causes a Commotion." (Edison. Wed., December 23).—One of the Buster Brown series. Buster gets a box of sneezing powder, which has a very violent effect, and by its wide use breaks up the family peace very

badly. On the same reel with "'Twas the Night Before Christmas."

"The Fable of the Husband Who Showed Up and Did His Duty." (Essanay. Wed., December 23).—Richard C. Travers, Helen Dunbar and Gerda Holmes take the leading parts in this George Ade fable. Mrs. Clymer has social aspirations and a husband who does not care for her shin-digs. Being egged on by his wife he finally attends one and extends himself in paying attention to a pretty grass widow. His wife decides that he had better keep away in the future. The moral is: Solomon proved his wisdom by marrying all of his wife's friends, but the modern wise man passes them up.

"The Suffering of Susan." (Biograph. Thurs., Dec. 24).—A dramatic story with a touch of comedy. A girl thinks she can become a great actress. Her sweetheart succeeds in convincing her that she has a mistaken view of life. Irene Howley is the ambitious girl.

"A Soldier of the Peace." (Lubin. Two reels. Thurs., Dec. 24).—A strong story based on the saying, "I could not love thee, dear, so much, loved I not honor more." A young health officer leaves his wife during their honeymoon to fight an epidemic in his home town. The selfish girl says that if he goes it will be forever. Later she realizes her folly and nurses him through an attack of the disease. Earl Metcalf is seen as the conscientious young officer.

"The Knight Before Christmas." (Vitagraph. Thurs., December 24).—One of the "Sonny Jim" comedies. Sonny has just been told about the knights of ancient times, and when he discovers that a little girl of the tenements has no money to buy Christmas gifts he gives her the dollar which his father had given him to buy himself a gift. This results in some unexpected happiness for a number of people. Bobby Connelly is seen in his regular role as Sonny Jim.

"Slippery Slim Gets Square." (Essanay. Thurs., December 24).—Slippery Slim and Mustang Pete are again hot rivals for the hand of Sophie. This time Mustang steals Slippery's clothes, but Slippery gets even with him through the use of some powder which causes Sophie to think that Mustang has smallpox and to turn him out of the house.

"Sweeney's Christmas Bird." (Vitagraph. Fri., December 25).—An amusing slapstick comedy. A man going to bury a dead parrot takes too many drinks and exchanges the bird with a friend who is taking home a turkey. A general rough-house is the result. Hughie Mack, Flora Finch, William Shea and Kate Price compose the quartet of fun makers.

"Doc Yak and Santa Claus." (Selig. Fri., December 25).—Sidney Smith, the Chicago Tribune's cartoonist, devotes a whole reel to the ridiculously funny escapades of Doc Yak and Santa Claus. Doc has an interesting scrap with Jack-in-the-Box which Santa and his reindeer have brought him by the approved chimney route. Very clever and exceptionally well done.

"The Premature Compromise." (Edison. Two reels. Fri., Dec. 25).—The second of the series dealing with the adventures of "Young Lord Stranleigh." These stories appeared some time ago in the "Saturday Evening Post." Robert Barr is the author, and they are all full of interest. In this story some mine swindlers try to beat Lord Stranleigh and his mining expert. They find that the young nobleman is by no means so impractical as he would have people believe. Marc MacDermott is seen in his role as Stranleigh.

"The Lure of the Green Table." (Lubin. Fri., Dec. 25).—Virtue is not exactly its own reward in this story. On the contrary, a man gambles until he loses everything he owns, including a farm he has just bought, and then when his sweetheart appears in the little Western town everything is handed back to him. William E. Parsons is seen as the gambler and Dolly Larkin as his fiancée.

"The Way Home." (Biograph. Fri., Dec. 25).—The ruin, or what looks like the ruin, of a young chap is brought about by a feminine crook and her accomplice. When ill in a strange town the woman is nursed back to health by the parents of the man she had robbed. His

whereabouts are unknown to his parents, and to partly atone for her act the girl brings the young fellow home. The woman is played by Isabel Rea and her victim by Curtis Cooksey.

"Brannigan's Band." (Lubin. Sat., Dec. 26.)—A slapstick comedy dealing with the misadventures of a volunteer band in a small village. Mrs. Casey finally subdues the musicians by her own adaptation of the water cure. On the same reel with "A Troublesome Cat."

"A Troublesome Cat." (Lubin. Sat., Dec. 26.)—A cartoon picture by Vincent Whitman. On the same reel with "Brannigan's Band."

"An Affair for the Police." (Vitagraph. Two reels. Sat., December 26.)—When a detective is engaged to guard the wedding gifts the bride's sister thinks that it is an insult to the guests. Later everyone is surprised to find that the most valuable of all the gifts has been stolen. The detectives do some heavy work and discover that the bride's sister is the thief. It develops that she took the necklace to show how easily the detectives could be fooled. Leah Baird is seen as the bride.

"The Champion Bear Slayer." (Selig. Sat., December 26.)—Some trained bears, particularly a roly-poly little cub, make this an unusually amusing comedy. The father, a self-confessed hero of many bear hunts, is panic stricken at the sight of a tiny cub which his daughter has brought home. It looks to him like a life-sized grizzly, and pursues him all over the house until he calls out the police reserves for protection.

"Broncho Billy and the Sheriff's Office." (Esanay. Sat., December 26.)—Broncho Billy is requested to resign his office as sheriff. He does so, but later is reinstated in order to capture the bad man of the town, of whom the new sheriff is afraid. After he has captured the desperado he again takes off his badge in spite of the protests of the town council.

"His Unwitting Conquest." (Biograph. Sat., Dec. 26.)—The search for material and experience leads a novelist to an affair with an actress. The woman falls in love with him, and later when she discovers that he is married and that he was only studying her she destroys the manuscript of his great story. Vivian Prescott appears as the actress, with Hector V. Sarno as the novelist.

"The Man Who Vanished." (Edison. Sat., Dec. 26.)—Another story adapted from the Felix Boyd series "Below the Dead Line." Boyd, the detective, predicts the robbery of the Trinity Trust vault, and acting on his advice Central Office men head off the thieves before they get any money. Boyd then tells how he discovered the plot, and the ingenious way in which he traced out the plans of the master criminal.

UNIVERSAL PROGRAM

"A Page from Life." (Rex. Two reels. Sun., Dec. 20.)—Made by Frank Lloyd and his company, in which Herbert Rawlinson, Anna Little, William Worthington and himself play the leads. The story is about a man who is forced to turn crook. His daughter discovers it, and gives back her lover's ring, but death comes upon her father and she is clear to marry the man. Produced and played excellently. The interest is always held at the highest.

"The Baron's Bear Escape." (L. K. O. Sun., Dec. 20.)—Henry Bergman is featured as Baron Hazenfeffer in this comic offering. He has amorous intentions toward a young girl, and is furthered in his suit by father, but daughter has a young American in mind. The Baron goes hunting and the other man dresses as a bear and scares the wits out of the professed hunter. The thread of the story is lost in the mud hole appearing in the last scene in which all the characters are splashing in when the picture closes.

"The Jewel of Allah." (Eclair. Sun., Dec. 20.)—In India two men find a jewel in a newly fallen meteor. They take it to the ruler of the land who terms it a gift from Allah. The rays from it cause a blind man to regain his sight, and in America, where the jewel has been taken to be set, it performs the same charitable service to the jeweler's daughter. The story is well constructed, but would be more powerful if it were probable.

"The King and the Man." (Victor. Two reels. Mon., Dec. 21.)—Instead of turning his attention to fair damsels in distress, Terrence O'Rourke in this, the fourth of his adventures, aids a king. The king is the ruler of a small European country, and sore pressed by a neighboring country of great power. He is ordered to abdicate or accept death at the hands of spies of the other power. Terrence, who happens to be his double, succeeds, after many difficulties have been overcome, in getting the king away in safety, and

throwing his pursuers off the track. Just as O'Rourke thinks his mission complete, the king returns, because the girl he loves has been left behind him. He then signs his abdication and is a free man to marry the girl. Excellent double exposure work appears in several places in the final reel.

"Carmen's Romance." (Sterling. Mon., Dec. 21.)—One of the Sterling kid comedy-dramas with Billy Jacobs and the usual supporting cast. It is funny, most of the humor resulting from the antics of two of the members of the cast, the villain and the hero, while in a well. Billy is endeavoring to pull them out. Billy plays the part of the peacemaker and smoothes things over in the finale. This will please more than the ordinary kid comedy, although it might be appreciated more if childish actions were resorted to by the children instead of their emulation of grown-ups.

"For I Have Toiled." (Nestor. Tues., Dec. 22.)—This is an interesting story of unusual human interest, of the kind that leaves a pleasant taste in one's mouth at its termination. The unimportant love story that appears is not necessary to keep up the interest. Murdock Mac Quarric in the role of the philanthropical employer, who has been asked by a business associate to cut his employees' salaries, visits and stays among them in the guise of a workman, discovers that his men are obliged to strive hard for the little they receive and thereafter determines to run his plant on the profit-sharing plan.

"The Call of the Waves." (Gold Seal. Two reels. Tues., Dec. 22.)—This is one of Francis Ford's productions featuring Ford himself and Grace Cunard. The story is one of the uncultured, wild girl, who is taken from her childhood home by the sea and adopted by a woman of social prominence. Finally, after suffering the pangs of unsuccessful gambling at Monte Carlo, she is rescued from compromising straightjackets by her old lover; later they are married. Miss Cunard doesn't quite fit her part, but in its entirety the picture will afford good entertainment.

"Vivian's Beauty Test." (Crystal. Tues., Dec. 22.)—If anyone takes pleasure in watching persons who, if they left themselves as nature made them, could pass off as reasonably nice looking, comfort their faces and bodies and devise schemes in which they make themselves appear repelling to a great degree, he will enjoy this picture. If he doesn't he will not.

"Love and Spirits." (Joker. Wed., Dec. 23.)—Ernest Shields has a comedy style of his own creation which never seems to grow at all tiresome. He is almost always funny and here he is so comical that some will be crying from laughter all the way through the picture. He flirts with a girl, and then makes a date to go and see her. He is welcomed by the girl's parents and invited to partake in a spiritualistic meeting. He is frightened and runs away. How he bribes the spiritualist to let him appear as the girl's future husband and the discovery of the deception bring the reel to an uproarious close. Betty Shade is the girl.

"The Fortunes of Margaret." (Eclair. Two reels. Wed., Dec. 23.)—This is an unusual offering produced in a very effective manner and played nearly as well with Isabel Daintry and Max Fisher in the leading parts. Margaret assumes the blame of a theft for the love of her brother and leaves home. She is married happily. Later her brother breaks into her house and is killed by a policeman. The girl is united with her father through her child. This sounds dull, but it isn't. It is a well told tale which holds the interest throughout.

"Innocent Dad." (Sterling. Thurs., Dec. 24.)—In which John Brennan, one time of the Kalem company, makes his debut into the ranks of the Universal. Playing the name part of this comedy, it is poor Dad who gets into a whole lot of trouble when he is the most innocent one of the crowd. There is a grand mix-up in a dining room which is fairly humorous. The picture is a comedy of the average order, nothing startlingly funny, but everything passably humorous.

"The Big Sister's Christmas." (Rex. Two reels. Thurs., Dec. 24.)—The atmosphere of niceness that pervades this entire picture is admirable and beautifully carried out by Herbert Rawlinson, Anna Little, William Worthington, Helen Leslie and Dick Rosson. It is more true to life than many, and a very timely picture for the Christmas season. The older sister of a moderately well-off family runs the home and does everything to make her father and younger sister more comfortable, neglecting herself. How she becomes, righteously, the least bit dissatisfied and how she finds the man she loves makes a wonderfully entertaining number.

"Who Stole the Bridegroom?" (Nestor. Fri., Dec. 25.)—This is one of the pictures that Eddie Lyons produced while Mr. Christie was visiting New York, and he has made an excellent comedy, assisted by Lee Moran and Bess Meredith. Lee Moran is uproariously funny as the de-

tective. Eddie is about to be married and visits the man who is to be his best man, only to find himself quarantined, because the child has smallpox. Eddie then attempts to escape from the house, but is frustrated a number of times by the detective. He finally manages to escape and gets married, and it develops that the baby was infected with the innocent malady of prickly heat.

"The Accusation." (Victor. Two reels. Fri., Dec. 25.)—There are many and tense situations in these two reels that have been developed in a manner that is most powerful. There are two rivals, one of them very bad, who when the other is engaged to the girl accuses him of being the father of a baby belonging to himself. Things reach their height when the girl who was wronged by the defeated rival openly denounces him in the presence of the other woman, her father and lover. Then all ends well. Harry Myers directed and played the male lead, and is to be praised. Rosemary Theby plays opposite, plays her part well and looks as pretty as ever. Brainsley Shaw is an excellent heavy, whose reformation leaves the story without one. Neil Moran is the father and Ruth Fielding the other girl.

"Hot Stuff." (Joker. Sat., Dec. 26.)—A lively farce in which William Franey, Gale Henry and Jane Bernouddy are the principal characters. Due to the mischievous actions of a tramp two women, both accomplished pie bakers, become antagonistic toward one another. They each bake a pie; one has cayenne in it and the other tabasco. When they are eaten violent action begins and only stops because the reel closes. This will be liable to create a good bit of laughter.

"The Rustler Outwitted." (Frontier. Sat., Dec. 26.)—A hired detective is unable to discover the rustler and would-be assassin of the ranch owner and departs after a fruitless search. It then remains for the ranchman's daughter to arrest him by disguising herself as a man and bringing him to the sheriff. This makes a pleasing offering, with Joe Franz in the rustler's role.

"The Law of the Range." (101 Bison. Three reels. Sat., Dec. 26.)—Although this picture contains an excellent story, there is not enough action in it to warrant three reels. If it were all as lively as the last reel, it would be excellent, but unfortunately it is not. The acting of William Clifford, Sherman Bainbridge, Marie Walcamp and Val Pal is as good as ever. The small ranchman resists the encroachments of his powerful neighbor and for revenge steals his cattle. His enemy then lays siege to Smith's place and finally captures him and is on the point of hanging him, when his little child begs his captor not to and he lets the man go for her sake.

MUTUAL PROGRAM

"Fatty and Minnie-He-Haw." (Keystone. Two reels. Mon., Dec. 4.)—In which Roscoe Arbuckle gets into a world of trouble with an Indian squaw who desires his hand in marriage. He runs away from her, and takes refuge in a bar room, where he and a gentleman aptly termed "the last of the booze fighters" will surely create roars of laughter. This is another of the side-splitting two-reelers that this company is turning out. It will be received with just as much enthusiasm as the others.

"In the Conservatory." (Princess. Fri., Dec. 11.)—This is a detective crook story which offers a surprise in almost every scene and is naturally of great interest from start to finish. The man, who at an entertainment gives himself up as a crook to save the good name of a maid, turns out to be a detective, while the man who posed as a detective is really the crook. This seems sadly impossible in the telling, but the manner in which the picture is produced makes it quite convincing and strong. Boyd Marshall appears as the detective and Mayre Hall is the wrongly accused girl.

"In Tune." (American. Two reels. Mon., Dec. 14.)—The author-business man, who lives a very unhappy married life, is much in love with his stenographer. Because of his absentmindedness he signs his name to a blank piece of paper, and a clerk in his establishment uses this to further his dishonest ends. The author suspects the stenographer and she gets to work on the case and apprehends the real culprit. After this the author's wife dies and the story ends as would be expected. Although these reels contain two widely different themes, they are well combined, so that the story is good in regard to continuity. Many of the scenes transpire in an office in which the lighting is poor. Aside from this the photography is good. Ed. Coxen is the author, Winnifred Greenwood the stenographer, George Field the dishonest clerk and Charlotte Burton the author's first wife.

"When East Meets West." (Thanouser. Sun., Dec. 13.)—This reel made by the Thanouser company in the Yellowstone National Park com-

vides a fairly entertaining love story, with a very beautiful and impressive scenic. Various views such as the upper and great falls of the Yellowstone River and Old Faithful, the hourly geyser, are shown. Excellent photography materially heightens the value of every outdoor scene. The story presented is nothing unusual but is continually of interest. Mignon Anderson and Morris Foster are the lovers. The ending of the story is rather abrupt, but otherwise is well worked out.

"Her Younger Sister." (Beauty. Tues., Dec. 15.)—A light heart interest number concerning two sisters and a man who at first is in love with the older of the two. She promises to marry him only when her sister is old enough to take care of her invalid father. In ten years the man returns, and finds the younger sister much more to his liking, so the elder resigns herself to caring for her father for the rest of her days. This is acted well by Charlotte Burton in the name part, Joseph Harris as the lover and Gladys Kingsbury as the older sister. Fred Gamble as the grouchy old father furnishes quite a bit of comedy.

"The Silent Way." (American. Wed., Dec. 16.)—The Indian foreman of a ranch steals away his employer's sister, who is slowly pining away from tuberculosis. In time he returns her, entirely rid of the malady. This is an unusual offering and very impressive. The scenes are artistically chosen, and are supported by excellent photography, except for a few scenes. Winnifred Greenwood is the girl and George Field is the Indian. Ed. Coxen appears as the ranch owner.

"Hogan's Annual Spree." (Keystone. Thurs., Dec. 17.)—The first part of this picture is uproariously funny, most of the laughs resulting from Charles Murray's actions at the well-known bar. The latter part, although very funny, is not quite so good. After Hogan has consumed a considerable amount of liquor, he enters a house and changes places with a man who is impersonating Santa Claus for the amusement of his little girl. He is discovered by the police in the end and is taken to jail.

"Trapped by Heliograph." (American. Fri., Dec. 18.)—This film shows, as the title implies, the way in which a group of robbers are trapped by the use of the heliograph, a device used in the army for signaling purposes. By reflecting the sun's rays from a series of mirrors, messages are sent from one post to another. This story is fair, but not up to American standard. The company is unfamiliar to the writer and obviously to the camera. The photography is rather poor. The film is tinted a blazing light yellow and is rather hard on the eyes.

"The Passing of Two-Gun Hicks." (Broncho. Two reels. Wed., Dec. 23.)—More or less of a character study, with William S. Hart in the name part. The picture depicts how the passionate pleadings of a woman finally saved her drunken husband from the fury of the Two-Gun Man. Although Mr. Hart changes his facial expression hardly at all, his clear portrayal of varying emotions is entirely satisfactory. Closeups are employed frequently to show the expression in the man's eyes, and the effect that they create is clear and forcible. The picture really contains little action, outside of a short gun fight, but never for a moment is the interest lost. The great magnetism of the leading player, which shows up so well on the film, is probably responsible for the production's attractive powers, as well as the heart interest subject dealt with. Mr. Hart also produced the picture.

"The Last of His Line." (Domino. Two reels. Thurs., December 24.)—This film is one of unusual merit and dramatic force. Further it is a play with an Indian as the chief character. The part is that of an old chief, and it is played with remarkable feeling and force by the aged redskin who has the role. The chief's son comes home to rule the tribe. He has been educated among the whites, but the only thing he has learned has been to drink. He nearly breaks the proud old chief's spirit by his behavior, but the climax comes when the youth leads a bunch of renegades in an attack on the army paymaster. His father happens to come on the scene in time to shoot down his own son and others of the leaders. The remaining bandits run away, but the last of the army men has been killed. The chief carries his dead son to the army wagon and when the belated rescuers arrive tells them that the boy fell helping to defend his father's friends. The army men give him a military funeral and only the old chief knows he died in disgrace.

"Her Mother's Voice." (Royal. Sat., Dec. 26.)—The hod carrier's daughter inherits everything from her mother, even to her voice, which she is in the habit of trying out at sundry moments, to the great distress of the neighborhood. The antics of all the characters are very funny, especially those of a horse made up of two men. The comparative freshness of the plot and the way it is worked out will cause mild laughter throughout its length.

"In the Sage Brush Country." (Kay-Bee. Two reels. Fri., Dec. 25.)—William S. Hart appears in his familiar role of bandit again, in this release. He sets out to rob a girl, but instead protects her from a Mexican bandit, after that escorting her safely to the mine, to which she is carrying the payroll. Rhea Mitchell is the girl, Herschel Mayall is her father and Thomas Kurihara plays the part of the other bandit. This offering keeps one in continual suspense. Mr. Hart's characterization of the bandit is most impressive, and although some may think he plays to the gallery, his performance will most surely be appreciated. Mr. Hart also produced the picture.

WARNER'S FEATURES

"O'Brien Finds a Way." (Premier.)—O'Brien conceives the conventional idea of tying fruit on the trees of his property and selling it at a handsome price. He gives the money to his wife-to-be and she buys the land back from the stranger. O'Brien breaks the engagement, and the widow marries another. A laughable offering played in an average manner by the cast.

"The Champeen Detective." (Superba.)—Charlie De Forrest appears as the detective and will be responsible for a number of laughs. He solves a burlesque mystery in a corresponding style. The jerky, quick actions of the characters, due to trick camera work, is another comical point in the picture, which all in all is a fine comedy.

"Waddling Willie." (Pikes Peak.)—Trick photography is in a large measure responsible for the humorous side of this reel. A tramp gets a job as a chauffeur (in his dream), and is given one of those much-abused automobiles to drive. He falls out of it and proceeds to chase it, but after a while the car turns around and chases him. After a time Willie wakes up and someone is throwing ashes on his head.

"The Heart of a Man." (Pikes Peak. Two reels.)—This is a western drama of unusual interest, simply because it contains a theme that is not overworked. It is produced well, delving sometimes unnecessarily into small details, but on the whole the story is presented in an effective manner. The photography is clear, but in some places in the print shown the film seems light struck, but very slightly. After the husband has been killed by a blast, his wife goes on working the mine, only aided by an old Indian and another man who has fallen in love with her. After they have struck gold, a town springs up around the mine. A body of claim jumpers attempt to put the woman and her friends out of the way. They bind the young man and then set fire to the owner's house, but the former escapes and rescues the woman he loves. The scene is quite thrilling and brings the good picture to an equally good close. The only improbable part of it is that the fire devours the house with such rapidity that no one could imagine that a human being was inside.

"Joe's Retribution." (Premier.)—This reel is more or less of a character portrayal rendered by Joe Franz, who assumes the part of a man crazed by the thought of a crime which he never committed. But "music hath charms," and Joe's mind leads him to a house where a child is playing on a toy piano. He rescues the girl from a fire and afterwards when his mind is restored returns to marry the girl he loves. Good photography is the order throughout this reel. Fred Church appears in a small part.

"Oh, You Pop." (Starlight.)—Showing how a perpetual joker finally won the girl of his heart by impersonating a woman and getting on the right side of father. Father discovers the deception in time and begins to get furious, but all ends well after quite a lively chase has been participated in by all the characters in the comedy.

"Bangs' Burglar Alarm." (Evans.)—Bangs invents a burglar alarm which is placed on the window of a house. When the burglar opens the window the device shoots. It is a great success, and Bangs celebrates and comes home slightly the worse for wear. He attempts to climb in his own window and is blown to the ground. The whole household is awakened and Bangs receives a severe drubbing from his wife. This will cause a few laughs.

WEEKLIES

"Mutual Weekly, No. 102." (Thurs., Dec. 10.)—Prominent women of the national capital aid the suffering Belgians in various ways; scenes in the annual dog shows of New York and Boston; annual Jack rabbit drive near Pasco, Wash.; a boat with nobody aboard, controlled by wireless waves is tested by the United States government at a distance of twenty-eight miles from a shore station; Richard Croker, former Tammany leader, is married to an Indian princess, New York City; Eddie Pullen driving a Mercer car

wins the \$12,000 Corona race at an average speed of eighty-six miles an hour; the arrival of General Funston and his troops at Galveston, Tex., after evacuating Vera Cruz; war scenes, including a battle in the skies between an aeroplane and Zeppelin.

Mutual Weekly No. 103. (Thurs., December 17.)—This number is rather more interesting than the average. Its scenes from the seat of the European war are well chosen and entirely in concurrence with President Wilson's neutrality "spiel." There are seven scenes on this, and about nine dealing with subjects in this country. The steamers "Lusitania" and "Hanalei" are shown, the former sailing from New York, and the latter on the reefs outside Golden Gate Harbor, Cal.

Thrilling scenes are shown of the great storm that visited the Eastern coast and did \$1,000,000 damage in three days and cost 20 lives. The U. S. S. Arkansas is shown passing under Brooklyn Bridge, New York, on her return from Vera Cruz. Altogether a very good number.

Hearst-Selig News Pictorial. (Mon., Dec. 7.)—This number is devoted to happenings in this country, only one or two items dealing with the European War. This is a relief from the regular run of weeklies. The most prominent showing deals with the Steamer Hanalei, driven by a gale, strikes on Duxbury Reef, nine miles from San Francisco Harbor. Life savers had a long and hard struggle to save the survivors. The Army-Annapolis football game; U. S. soldiers from Vera Cruz disembarking at Galveston, Tex., and a number of other interesting items go to make this a very interesting number.

KRITERION PROGRAM

"The Tattooed Man." (All Comedy Company.)—A merry single reeler produced by Alexander Frank, in which a tattooed man creates havoc, mainly among a body of would-be suffragettes. One of them insists on marrying him, finally. This will afford much laughter, although the man, who is crazy as well as tattooed, jumps a little too much before starting on his various runs.

"And Percy Made Good." (Santa Barbara.)—This comedy is produced by Bert Angeles and although the plot has been used more than any other, it will be continued to be used, and is all very funny as presented in this picture. Mary Ruby, Harry Fisher and Sidney de Grey are cast in the principal roles, and perform well. The youth who desires the daughter of a grouchy old man finally wins her by saving his would-be parent from losing all his money. He does this by stealing a check and getting it cashed before the bank fails.

ECCLECTIC—PATHE

"The Runaway Leopard." (Pathe. Split reel.)—A re-issue of an exceptionally fine animal comedy first shown two or three years ago. A leopard runs at large and causes the strangest sort of mishaps.

"The Quality of Mercy." (Pathe. Two reels.)—Fine acting and striking light and scenic effects characterize this strong drama. A girl to avoid a distasteful marriage goes to the apartment of her lover. Her father comes after her, and arrives while the girl is talking with her sweetheart's mother, who has been summoned. In a burst of passion he attempts to kill the man, but only wounds him. The mother has the older man arrested on a charge of attempted murder, but her son refuses to appear against the father of his sweetheart, and at the end there is a bappy reconciliation.

INCORPORATIONS

At Albany, N. Y.: EASTERN TRAVELING PHOTO THEATRE CORPORATION. Motion picture, theatrical; \$5,000; Manhattan. David Chanak, Hyman Seigel and Jacob Armband, of New York.

AMERICAN IRISH PLAYERS' CO., INC. Theatrical, motion picture, etc.; \$25,000; Manhattan. Thos. Phillips, of Boston, Mass.; Deborah M. Byrne and Stephen A. Colahan, of Brooklyn.

THE BANNER PHOTO PLAY COMPANY, INC. Managing moving picture houses; \$2,500; Manhattan. Samuel Slosum, B. Bergowitz and Chas. G. Reider, of New York.

VISTA CINEMATOGRAPH COMPANY. Deal in and manufacture cameras and moving picture supplies; \$10,000; Manhattan. Jos. Friedman, Geo. Chrystoskos and Chas. S. Frank, of New York.

BREWSTER FILM CORPORATION. Motion picture business, manufacturing films, camera, appliances, etc.; \$2,000; Manhattan. Samuel C. Worthen, H. T. Randall and Bradley Shawman, of New York.

(Continued on page 62.)

Record of Current and Coming Releases

GENERAL FILM PROGRAM

RELEASES OF NEXT WEEK

Monday, December 21, 1914.

BIOGRAPH—A Matter of Court, and The Dentist's Janitor, C., Split Reel.....	16687
EDISON—The Adventure of the Wrong Santa Claus, C., 1000	16693
ESSANAY—Their Cheap Vacation, C., 1000.....	16695
KALEM—The Mayor's Secretary, D., 2000.....	16688
LUBIN—In Port o' Dreams, D., 1000.....	16696
SELIG—Hearst-Selig News Pictorial, No. 85, N., 1000.	16694
SELIG—Till Death Us Do Part, D., 2000.....	16690
VITAGRAPH—Arthur Truman's Ward, D., 1000.....	16692

Tuesday, December 22, 1914.

BIOGRAPH—On the Heights, D., 2000.....	16704
EDISON—Olive Is Dismissed, D., 1000.....	16697
ESSANAY—The Volunteer Burglar, D., 1000.....	16698
KALEM—The Winning Whiskers, C., 1000.....	16703
LUBIN—His Suicide, and Flossie's Daring Loyalty, C., Split Reel	16702
SELIG—Wade Brent Pays, D., 1000.....	16699
VITAGRAPH—By the Governor's Order, D., 2000.....	16700

Wednesday, December 23, 1914.

EDISON—'Twas the Night Before Christmas (Fantasy), and The Tip of the Dark Continent, E., Split Reel..	16706
ESSANAY—The Fable of the Husband Who Showed Up and Did His Duty, C., 1000.....	16709
KALEM—The Fatal Opal, D., 2000.....	16707
LUBIN—The Single Act, D., 2000.....	16712
SELIG—One Traveler Returns, D., 1000.....	16711
VITAGRAPH—The Professor's Romance, C., 1000....	16710

Thursday, December 24, 1914.

BIOGRAPH—The Suffering of Susan, C., 1000.....	16714
ESSANAY—Slippery Slim Gets Square, C., 1000.....	16715
LUBIN—A Soldier of Peace, D., 2000.....	16716
MINA—A High Old Time, C., 1000.....	16720
SELIG—Hearst-Selig News Pictorial, No. 86, N., 1000..	16719
VITAGRAPH—The Knight Before Christmas, C., 1000.	16718

Friday, December 25, 1914.

BIOGRAPH—The Way Home, D., 1000.....	16729
EDISON—The Premature Compromise, D., 2000.....	16721
ESSANAY—Any Woman's Choice, D., 2000.....	16723
KALEM—The Reformation of Ham, C., 1000.....	16725
LUBIN—The Lure of the Green Table, D., 1000.....	16728
SELIG—Doc Yak and Santa Claus, C., 1000.....	16726
VITAGRAPH—Sweeney's Christmas Bird, C., 1000....	16727

Saturday, December 26, 1914.

BIOGRAPH—His Unwitting Conquest, D., 1000.....	16736
EDISON—The Man Who Vanished, D., 1000.....	16730
ESSANAY—Broncho Billy and the Sheriff's Office, D., 1000	16731
KALEM—The Escape on the Limited, D., 1000.....	16735
LUBIN—Brannigan's Band, C., and A Troublesome Cat, C., Split Reel.....	16732
SELIG—The Champion Bear Slayer, C., 1000.....	16737
VITAGRAPH—An Affair for the Police, C., 2000.....	16733

RELEASES OF THE WEEK AFTER

Monday, December 28, 1914.

BIOGRAPH—The House of Silence, D., 1000.....	
EDISON—Mr. Daly's Wedding Day, C., 1000.....	
ESSANAY—Sweedie Collects for Charity, C., 1000.....	
KALEM—The Black Sheep, D., 2000.....	
LUBIN—Patsy at School, Patsy Bolivar Series No. 1, C., 1000	
SELIG—Hearst-Selig News Pictorial No. 87, N., 1000..	
SELIG—The Flower of Faith, D., 2000.....	
VITAGRAPH—The Product, D., 1000.....	

Tuesday, December 29, 1914.

BIOGRAPH—The Crimson Moth, D., 2000.....	
EDISON—The Lesson of the Flames, D., 1000.....	
ESSANAY—The Way of the Woman, D., 1000.....	
KALEM—Love, Oil and Grease, C., 1000.....	
LUBIN—A Cowboy Pastime, C., 1000.....	
SELIG—Cactus Jake, Heart Breaker, C., 1000.....	
VITAGRAPH—Behind the Clouds, D., 2000.....	

Wednesday, December 30, 1914.

EDISON—The Courtship of the Cooks, C., 1000.....	
ESSANAY—Two Dinky Little Dramas of a Non-Serious Kind, 1000.....	
KALEM—The Derelict, D., 2000.....	
LUBIN—The Intriguers, D., 2000.....	
SELIG—The Old Letter, D., 1000.....	
VITAGRAPH—Forcing Dad's Consent, C., 1000.....	

Thursday, December 31, 1914.

BIOGRAPH—Two Stray Souls, D., 1000.....	
ESSANAY—Snakeville's Rising Sons, C., 1000.....	
LUBIN—Fate and Fugitive, D., 2000.....	
MINA—The Siege of Liege, C., 1000.....	
SELIG—Hearst-Selig News Pictorial No. 88, N., 1000..	
VITAGRAPH—Love Will Out, D., 1000.....	

Friday, January 1, 1915

BIOGRAPH—The Efficiency Squad, C.; Diogenes Weekly No. 4-11-44, C., Split Reel.....	
EDISON—Young Mrs. Winthrop, D., 2000.....	
ESSANAY—The Shanty at Trembling Hill, D., 2000...	
KALEM—Getting Father's Goat, C., 1000.....	
LUBIN—Clean Slate, D., 1000.....	
SELIG—Wipe Yer Feet, C., 1000.....	
VITAGRAPH—Antie's Portrait, C.; Rattlesnakes, Ed, Split Reel	

Saturday, January 2, 1915.

BIOGRAPH—All for the Boy, D., 1000.....	
EDISON—Uncle Crusty, C., 1000.....	
ESSANAY—Broncho Billy and the Escaped Bandit, D., 1000	
KALEM—The Girl Telegrapher's Peril, D., 1000.....	
LUBIN—He Gave Him a Million, C.; What He Forgot, C., Split Reel.....	
SELIG—Lassoing a Lion, D., 1000.....	
VITAGRAPH—In the Latin Quarter, D., 2000.....	

RECORD OF CURRENT AND COMING RELEASES — Continued

UNIVERSAL PROGRAM RELEASES OF NEXT WEEK

Monday, December 21, 1914.

IMP—In Sunny Spain, Mary Pickford Reissue, C., 1000. 4427
 STERLING—Carmen's Romance, C., 1000..... 4430
 VICTOR—Terence O'Rourke, "The King and the Man,"
 2000 4428

Tuesday, December 22, 1914.

CRYSTAL—Vivian's Beauty Test, C., 1000..... 4435
 GOLD SEAL—The Call of the Waves, D., 2000..... 4433
 NESTOR—For I Have Toiled, D., 1000..... 4436

Wednesday, December 23, 1914.

ANIMATED WEEKLY—Weekly No. 146, N., 1000.... 4441
 ECLAIR—The Fortunes of Margaret, D., 2000..... 4438
 JOKER—Love and Spirits, C., 1000..... 4437

Thursday, December 24, 1914.

IMP—No Release This Week.....
 REX—The Big Sister's Christmas, D., 2000..... 4442
 STERLING—Innocent Dad, C., 1000..... 4444

Friday, December 25, 1914.

NESTOR—Who Stole the Bridegroom, C., 1000..... 4445
 POWERS—Hunting in Crazyland, Cart., and Japanese
 Silk Industry, E., Split Reel..... 4446
 VICTOR—The Accusation, D., 2000..... 4447

Saturday, December 26, 1914.

101 BISON—The Law of the Range, D., 3000..... 4452
 FRONTIER—The Rustler Outwitted, D., 1000..... 4451
 JOKER—Hot Stuff, C., 1000..... 4450

Sunday, December 27, 1914.

ECLAIR—For the Defense, D., 1000..... 4458
 L-KO—The Manicure, C., 1000..... 4457
 REX—Her Escape, D., 2000..... 4455

RELEASES OF THE WEEK AFTER

Monday, December 28, 1914.

IMP—The Submarine Spy, D., 2000.....
 STERLING—The Chief's Revenge, C., 1000.....
 VICTOR—Mary Fuller in "Virtuoso," D., 1000.....

Tuesday, December 29, 1914.

CRYSTAL—The Fat Girl's Romance, C., 1000.....
 GOLD SEAL—A Study in Scarlet, D., 2000.....
 NESTOR—When Its One of Your Own, D., 1000.....

Wednesday, December 30, 1914.

ANIMATED WEEKLY—Weekly No. 147, N., 1000....
 ECLAIR—Within an Inch of His Life, D., 2000.....
 JOKER—The Village Post Master, C., 1000.....

Thursday, December 31, 1914.

IMP—Winning the Prize, D., 1000.....
 REX—Hounded, D., 2000.....
 STERLING—Love and Water, C., 1000.....

Friday, January 1, 1915.

NESTOR—Pruning the Movies and Mt. St. Bernard
 Switzerland, Split Reel.....
 POWERS—No Release This Week.....
 VICTOR—The Beautiful Unknown, D., 3000.....

Saturday, January 2, 1915.

101 BISON—In Jungle Wilds, D., 2000.....
 FRONTIER—Christmas at Lonesome Gulch, D., 1000..
 JOKER—A Mixed Up Honeymoon, C., 1000.....

Sunday, January 3, 1915.

ECLAIR—The Hermit's Secret, D., 1000.....
 L-KO—Gem and Germs, C., 1000.....
 REX—The Sin of Olga Brandt, D., 2000.....

MUTUAL PROGRAM RELEASES OF NEXT WEEK

Monday, December 21, 1914.

AMERICAN—The Sower Reaps, D., 2000..... 02760
 KEYSTONE (Special)—Fatty and Minnie He-Haw, 2000
 KEYSTONE—Title Not Announced..... 02763
 RELIANCE—Our Mutual Girl, No. 49, 1000..... 02762

Tuesday, December 22, 1914.

BEAUTY—Brass Buttons, C., 1000..... 02768
 MAJESTIC—The Better Way, D., 1000..... 02767
 THANHOUSER—Under False Colors, D., 2000..... 02765

Wednesday, December 23, 1914.

AMERICAN—The Tin Can Shack, D., 1000..... 02772
 BRONCHO—The Passing of Two Gun Hicks, D., 2000. 02770
 RELIANCE—A Lucky Disappointment, 1000..... 02773

Thursday, December 24, 1914.

DOMINO—The Last of the Line, D., 2000..... 02775
 KEYSTONE—Title Not Announced..... 02777
 MUTUAL WEEKLY—Weekly No. 104, N., 1000..... 02778

Friday, December 25, 1914.

PRINCESS—The White Rose, D., 1000..... 02782
 RELIANCE—Bobby's Medal, D., 1000..... 02783
 KAY BEE—In the Sage Bush Country, D., 2000..... 02780

Saturday, December 26, 1914.

KEYSTONE—Title Not Announced..... 02786
 RELIANCE—The Exposure, D., 2000..... 02784
 ROYAL—Her Mother's Voice, D., 1000..... 02787

Sunday, December 27, 1914.

KOMIC—The Record Breaker, C., 1000..... 02790
 MAJESTIC—The Old Fisherman's Story, 2000..... 02788
 THANHOUSER—A Hatful of Trouble, C., 1000..... 02791

RELEASES OF THE WEEK AFTER

Monday, December 28, 1914.

AMERICAN—When a Woman Waits, D., 2000.....
 KEYSTONE—Title Not Announced, C., 1000.....
 RELIANCE—Our Mutual Girl, No. 50.....

Tuesday, December 29, 1914.

BEAUTY—Love Knows No Law, D., 1000.....
 MAJESTIC—Baby's Ride, 1000.....
 THANHOUSER—Lucy's Elopement, 2000.....

Wednesday, December 30, 1914.

AMERICAN—The Unseen Vengeance, D., 1000.....
 BRONCHO—The Face on the Ceiling, D., 2000.....
 RELIANCE—The Message, 1000.....

Thursday, December 31, 1914.

DOMINO—The Flower in the Desert, D., 2000.....
 KEYSTONE—Title Not Announced.....
 MUTUAL WEEKLY—No. 105, N., 1000.....

Friday, January 1, 1915.

KAY-BEE—The Deadly Spark, D., 2000.....
 PRINCESS—When Fate Rebelled, D., 1000.....
 THANHOUSER—Shep the Sentinel, D., 1000.....

Saturday, January 2, 1915.

KEYSTONE—Title Not Announced.....
 RELIANCE—A Banakie Maiden, D., 2000.....
 ROYAL—Putting It Over, 1000.....

Sunday, January 3, 1915.

KOMIC—Ethel Gets the Evidence (No. 14), C., 1000....
 MAJESTIC—Vengeance Is Mine, D., 2000.....
 THANHOUSER—The Bridal Bouquet, D., 1000.....

RELEASE DATES FOR READY REFERENCE

GENERAL FILM PROGRAM

BIOGRAPH

12—4.	Making Him Cough Up, C.....	
	Bertha, the Buttonhole-Maker.....	
12—5.	The Deacon's Son, D.....	1000
12—7.	Just a Kid, C.....	1000
12—8.	Cousin Pons, D.....	2000
12—10.	For Her People, D.....	1000
12—11.	And She Never Knew, D.....	1000
12—12.	Saved by Their Chee-ild! and Diogenes Weekly No. 13, C.....	1000
12—14.	The Sheriff of Willow Gulch, D.....	1000
12—15.	A Scrap of Paper, D.....	2000
12—17.	A Natural Mistake, C., and Red Dye, C., split reel.....	
12—18.	His Prior Claim, D.....	1000
12—19.	The Bond Sinner, D.....	1000
12—21.	A Matter of Court, C., and The Dent- ist's Janitor, C.....	Split reel
12—22.	On the Heights, D.....	
12—24.	The Suffering of Susan, C.....	1000
12—25.	The Way Home, D.....	1000
12—26.	His Unwitting Conquest.....	
12—28.	The House of Silence, D.....	1000
12—29.	The Crimson Moth, D.....	2000
12—31.	Two Stray Souls, D.....	1000
1—1.	The Efficiency Squad, C., and Diogenes Weekly No. 4-11-44, C.....	Split Reel
1—2.	All for the Boy, D.....	1000

EDISON

12—2.	A Double Elopement, C.....	1000
12—4.	Who Goes There? C.....	2000
12—5.	It's a Bear, C.....	1000
12—7.	Crystals, Their Making and Beauty, E. 500 Buster Brown Causes a Commo- tion, C.....	500
12—8.	The Rose at the Door, D.....	1000
12—9.	A Matter of High Explosives, C.....	1000
12—11.	The Best Man, D.....	2000
12—12.	The Stenographer, D.....	1000
12—14.	The Flirt, C.....	1000
12—15.	The Vanishing of Olive, D.....	1000
12—16.	On Christmas Eve, D.....	1000
12—18.	The Colonel of the Red Hussars, D.....	1000
12—19.	The Birth of Our Saviour, D.....	1000
12—21.	The Adventures of the Wrong Santa Claus, C.....	1000
12—22.	Olive Is Dismissed, D.....	1000
12—23.	'Twas the Night Before Christmas, Fant.....	550
	The Tip of the Dark Continent, E.....	450
12—25.	The Premature Promise, D.....	2000
12—26.	The Man Who Vanished, D.....	1000
12—28.	Dr. Daly's Wedding Day, C.....	1000
12—29.	The Lesson of the Flames, D.....	1000
12—30.	The Courtship of the Cooks, C.....	1000
1—1.	Young Mrs. Winthrop, D.....	2000
1—2.	Uncle Crusty, C.....	1000

ESSANAY

12—3.	Sophie's Fatal Wedding, C.....	1000
12—4.	The Time, the Place and the Man.....	2000
12—5.	Broncho Billy's Judgment, D.....	1000
12—7.	Sweetie and the Hypnotist, C.....	1000
12—8.	Mrs. Trenwith Comes Home, C.....	1000
12—9.	The Fable of the Bush-League Lover Who Failed to Qualify, C.....	1000
12—10.	Sophie's Sweetheart, C.....	1000
12—11.	Every Inch a King, two reels, D.....	2000
12—12.	Broncho Billy's Dad, D.....	1000
12—14.	Madam Double X, C.....	1000
12—15.	Loose Change of Chance.....	
12—16.	Two Pop-Up Fables, C.....	
12—17.	Snakeville's Blind Pig, C.....	1000
12—18.	The Girl from Thunder Mountain, D.....	1000
12—19.	Broncho Billy's Christmas Spirit, D.....	1000
12—19.	The Battle of Love (Special Feature), D.....	3000
12—21.	Their Cheap Vacation, C.....	1000
12—22.	The Volunteer Burglar, D.....	1000
12—23.	The Fable of "The Husband Who Showed Up and Did His Duty," C.....	1000
12—24.	Slippery Slim Gets Square, C.....	1000
12—26.	Broncho Billy and the Sheriff's Office, D.....	1000
1—1.	The Shanty at Trembling Hill, D.....	2000
1—2.	Broncho Billy and the Escaped Bandit, D.....	1000

KALEM

12—8.	In Dutch, C.....	1 reel
12—9.	The Mystery of the Yellow Sun- bonnet, D.....	2 reels

12—11.	The Bold Bandit and the Rah Rah Boys, C.....	1 reel
	The Invisible Power, Special, D.....	4 reels
12—12.	The Flying Freight's Captive, The Hazards of Helen, D.....	1 reel
12—14.	The Smugglers of Lone Isle, D.....	2 reels
12—15.	Cupid Backs the Winners, C.....	1 reel
12—16.	The Hate That Withers, D.....	2 reels
	The School for Scandal, D.....	4 reels
12—18.	Through the Keyhole, C.....	1 reel
12—19.	The Black Diamond Express, Haz- ards of Helen, D.....	1 reel
12—21.	The Mayor's Secretary, Alice Joyce Series, D.....	2000
12—22.	The Winning Whiskers, C.....	1000
12—23.	The Fatal Opal, D.....	2000
12—25.	The Reformation of Ham, C.....	1000
12—26.	The Escape on the Limited, D.....	1000
12—28.	The Black Sheep, D.....	2000
12—29.	Love, Oil and Grease, C.....	1000
12—30.	The Derelict, D.....	2000
1—1.	Getting Father's Goat, C.....	1000
1—2.	The Girl Telegrapher's Peril, D.....	1000

LUBIN

12—19.	Who's Who? C.....	400
	Shall Curfew Ring To-Night? C.....	600
12—21.	The Beloved Adventurer, No. 15, D.....	1000
12—22.	His Suicide, C.....	400
	Flossie's Daring Loyalty, C.....	600
12—23.	The Single Act, D.....	2000
12—24.	A Soldier of Peace, D.....	2000
12—25.	The Lure of the Green Table, D.....	1000

RELEASE DAYS

GENERAL FILM PROGRAM

Monday—	Biograph, Edison, Essanay, Hearst- Selig News Pictorial, Kalem, Selig, Vita- graph.
Tuesday—	Biograph, Edison, Essanay, Lubin, Selig, Vitagraph.
Wednesday—	Edison, Essanay, Kalem, Lubin, Selig, Vitagraph.
Thursday—	Biograph, Essanay, Hearst-Selig News Pictorial, Lubin, Mina, Selig, Vita- graph.
Friday—	Biograph, Edison, Essanay, Kalem, Selig, Lubin, Vitagraph.
Saturday—	Biograph, Edison, Essanay, Kalem, Lubin, Vitagraph, Selig.

UNIVERSAL PROGRAM

Monday—	Victor, Imp, Powers.
Tuesday—	Gold Seal, Crystal, Nestor.
Wednesday—	Nestor, Joker, Eclair.
Thursday—	Imp, Rex, Frontier, Sterling, Ani- mated Weekly.
Friday—	Nestor, Powers, Victor.
Saturday—	Joker, Frontier, 101 Bison.
Sunday—	Rex, Crystal, Eclair, L-KO.

MUTUAL PROGRAM

Monday—	American, Keystone, Reliance.
Tuesday—	Beauty, Majestic, Thanouser.
Wednesday—	American, Broncho, Reliance.
Thursday—	Domino, Keystone, Mutual Weekly.
Friday—	Kay-Bee, Majestic, Princess.
Saturday—	Keystone, Reliance, Royal.
Sunday—	Majestic, Komic, Thanouser.

12—26.	Brannigan's Band, C.....	400
	A Troublesome Cat, C.....	600
12—28.	Patsy Bolivar Series, No. L, Patsy at School, C.....	1000
12—29.	A Cowboy Pastime, C.....	1000
12—30.	The Intriguers, D.....	2000
12—31.	Fate and Fugitive, D.....	2000
1—1.	A Clean Slate, D.....	1000
1—2.	He Gave Him a Million, C.....	400
	What He Forgot, C.....	600
1—4.	Patsy Bolivar, Series No. 2, Patsy's First Love, C.....	1000
1—5.	The New Editor, C.....	400
	They Looked Alike, C.....	600
1—6.	Comrade Kitty, D.....	2000
1—7.	A War Baby, D.....	2000
1—8.	Love's Savage Hate, D.....	1000
1—9.	Feel My Muscle, C.....	1000
1—11.	Patsy Bolivar, Series No. 3, Patsy at College, C.....	1000
1—12.	Baseball and Trouble, C.....	1000
1—13.	When Honor Wakes, D.....	2000
1—14.	The Friendship of Lamond, D.....	2000
1—15.	Out of the Storm, D.....	1000
1—16.	Mr. Stubb's Pen, C.....	400
	Spaghetti and Lottery, C.....	600

MINA

12—17.	The Thrilling Adventures of Count Verance, C.....	1000
12—24.	A High Old Time, C.....	1000
12—31.	The Siege of Liege, C.....	1000
1—7.	Alias "Greased Lightning".....	
1—14.	Distilled Spirits.....	

SELIG

12—8.	Saved by a Watch, D.....	1000
12—9.	The Abyss.....	1000
12—11.	One Kiss.....	1000
12—12.	The Soul Mate.....	1000
12—14.	The Lure of the Windigo.....	2000
12—15.	The Man From the East.....	1025
12—16.	The Test.....	1000
12—18.	The Tail of a Coat.....	850
12—19.	The Lady or the Tiger, D.....	1000
12—21.	Not Announced.....	
12—22.	Wade Brent Pays, D.....	1000
12—22.	Hearst-Selig News Pictorial No. 83, N.....	1000
12—23.	One Traveler Returns.....	1000
12—24.	Hearst-Selig News Pictorial No. 84, N.....	1000
12—26.	Between Matinee and Night.....	1025
12—28.	Not Announced.....	
12—29.	Cactus Jake, Heart-Breaker, C.....	1000
12—29.	Hearst-Selig News Pictorial No. 85, N.....	1000
12—30.	The Old Letter, D.....	1000
12—31.	Hearst-Selig News Pictorial No. 86, N.....	1000
	The Champion Bear Slayer.....	1000
1—1.	Wipe Your Feet, C.....	1000
1—2.	Lassoing a Lion, D.....	1000

VITAGRAPH

12—10.	Pure Gold, D.....	1000
12—11.	A Strand of Blond Hair, C.....	1000
12—12.	How to Do It and Why, or Cutey at College, C.....	2000
12—14.	The Greater Love, D.....	1000
12—15.	Out of the Past, D.....	2000
12—16.	The Egyptian Mummy, C.....	1000
12—17.	A Question of Hogg's Hollow, C.....	1000
12—18.	Who Was Who in Hogg's Hollow, C.....	1000
12—19.	Mr. Santa Claus, C.....	2000
12—21.	Arthur Truman's Ward, D.....	1000
12—22.	By the Governor's Order, D.....	2000
12—23.	The Professor's Romance, C.....	1000
12—24.	The Knight Before Christmas, D.....	1000
12—25.	Sweeney's Christmas Bird, C.....	1000
12—26.	An Affair for the Police, C.....	2000
12—28.	The Product, D.....	1000
12—29.	The Plot, D.....	2000
12—30.	Forcing Dad's Consent, C.....	1000
12—31.	Love Will Out, C.....	1000
1—1.	Auntie's Portrait, C., and Rattlesnakes, Ed.....	Split Reel
1—2.	In the Latin Quarters, D.....	2000

UNIVERSAL PROGRAM

ANIMATED WEEKLY

12—9.	Weekly No. 144, N.....	1 reel
12—16.	Weekly No. 145, N.....	1000
12—23.	Weekly No. 146, N.....	1000

101 BISON

12—19.	The Christmas Spirit, D.....	2000
12—26.	The Law of the Range, D.....	3000
1—2.	In Jungle Wilds, D.....	2000

CRYSTAL

12—1.	Charlie Woos Vivian, and The Bar- ber Shop Feud; split reel.....	
12—8.	Vivian's Cookies, and Whose Baby, C., split reel.....	
12—15.	Such a Mistake, and The Glass Pis- tol, split reel.....	
12—22.	Vivian's Beauty, C.....	1000
12—29.	The Fat Girl's Romance, C.....	1000

ECLAIR

12—9.	For the Mastery of the World, D.....	3 reels
12—13.	The Mountain Traitor, D.....	1 reel
12—16.	A Game of Wits, D.....	2000
12—23.	The Fortunes of Margaret, D.....	2000
12—27.	For the Defence, D.....	1000
12—30.	Within an Inch of His Life, D.....	2000
1—3.	The Hermit's Secret, C.....	1000

FRONTIER

12—5.	The Circle of Gold, D.....	1000
12—12.	Her Higher Ambition, D.....	1 reel
1—2.	Christmas at Lonesome Gulch, D.....	1000



A new brand of comedy resulting from specialized study, backed by long successful experience and exactly shaped to meet the exhibitors' greatest need.



MINA

MADE AMERICA

FILMS



The most talked of pictures of the day. Artistic 1 and 3 sheet posters, national publicity.

MinA Films may be had of any licensed exchange. Released every Thursday on the regular



GENERAL FILM PROGRAM

RELEASE DATES FOR READY REFERENCE — Continued

GOLD SEAL

- 12— 1. Called Back, D.....4000
 12— 8. The District Attorney's Brother,
 D.....2 reels
 12—15. The Ghost of Smiling Jim, D.....2000
 12—22. The Call of the Waves, D.....2000
 12—29. A Study in Scarlet, D.....2000

IMP

- 11—19. The Universal Boy in "Cupid and the
 Fishes".....
 11—23. His Gratitude, Mary Pickford, Re-
 issue, D.....1000
 11—26. Human Hearts, D.....3000
 11—30. The Coward, D.....2000
 12— 3. The Young Philanthropist, D.....1000
 12— 7. The Outcome, Mary Pickford Re-
 issue, D.....1 reel
 12—10. Three Men Who Knew, D.....2 reels
 12—14. The Mill Stream, D.....2 reels
 12—17. Within the Gates of Paradise, Christ-
 mas Drama, D.....1000
 12—21. In Sunny Spain, Mary Pickford Re-
 issue, C.....1000
 12—28. The Submarine Spy, D.....2000
 12—31. Winning the Prize, C.....1000

JOKER

- 12— 5. A Dream of a Painting, and The Por-
 poise Fisheries, E.; split reel.....
 12— 9. The Genii of the Vase, and Alaska,
 E., split reel.....
 12—12. Love Disguised, and Building a Lo-
 comotive, E., split reel.....
 12—16. How Father Won Out, and The Ad-
 vent of the Ingrar Neilson, D.....2000
 12—19. His Doctor's Orders, C.....1000
 12—23. Love and Spirits, C.....1000
 12—26. Christmas Festivities, C.....1000
 12—30. The Village Post Master, C.....1000
 1— 2. A Mixed Up Honeymoon, C.....1000

L-KO

- 12—20. The Baron's Bear Escape, C.....1000
 12—27. The Manicure Girl, C.....1000
 1— 3. Gem and Germs, C.....1000

NESTOR

- 11—13. When the Girls Were Shanghaied, C.
 11—20. When Their Brides Got Mixed, C...
 India's Defender of the British Em-
 pire, E.....
 11—24. As We Journey Through Life, D.....1000
 12— 8. The Widows Last, D.....1 reel
 12—11. Their Ups and Downs, C.....1 reel
 12—15. The Boy Mayor, D.....1000
 12—22. For I Have Toiled, D.....1000
 12—25. Who Stole the Bridgroom? C.....1000
 12—29. When It's One of Your Own, D.....1000
 1— 1. Pruning the Movies, C., and Mt. St.
 Bernard, Switzerland, E.....Split Reel

NESTOR COMEDY

- 12—18. His Dog Gone Luck, and Here and
 There in Japan with Homer Croy,
 C.....

POWERS

- 11—20. A Scenario Editor's Dream, C.....
 11—27. Sissy Dobbins, Oil Magnate, D.....1000
 12— 4. The Heart of a Magdalene, D.....1000
 12—11. Adventures of the Nimble Dollar,
 D.....1 reel
 12—25. Hunting in Crazyland, Cart., and
 The Japanese Silk Industry, E.....
 Split reel

REX

- 11—22. Traffic in Babes, C.....
 11—26. Slow, but Sure, C.....
 11—29. Lights and Shadows, D.....2000
 12— 3. The Mystery of the Sea View Hotel,
 D.....2000
 12— 6. The Lion, the Lamb and the Man, D.....2000
 12—13. A Night of Thrills, D.....2 reels
 12—17. Ambition, D.....2000
 12—20. A Page from Life, D.....2000
 12—24. The Big Sister's Christmas, D.....2000
 12—27. Her Escape, D.....2000
 12—31. Hounded, D.....2000
 1— 3. The Sin of Olga Brandt, D.....2000

STERLING

- 12—24. Innocent Dad, C.....1000
 12—28. The Chef's Revenge, C.....1000
 12—31. Love and Water, C.....1000

UNIVERSAL IKE

- 10— 6. The Neglected Wife.....
 10—13. Mary Green's Husband, and Educa-
 tional, C.....
 10—13. Mary Green's Husband, and The
 Monkey Cabaret, C., split reel....

VICTOR

- 12— 7. Terence O'Rourke—The Inn of the
 Winged Gods, D.....2000
 12—11. The Little Gray House, D.....2 reels
 12—14. The Wayward Son, D.....1000
 12—18. Mary Fuller, in Heart of the Hills,
 D.....3000
 12—21. Terence O'Rourke, "The King and
 The Man," D.....2000
 12—25. The Accusation, D.....2000
 12—28. Mary Fuller in Virtuoso, D.....1000
 1— 1. The Beautiful Unknown, D.....3000

MUTUAL FILM PROGRAM

AMERICAN

- 12—14. In Tune, D.....2000
 12—16. The Silent Way, D.....1000
 12—18. Trapped by a Heliograph, D.....1000
 12—21. The Sower Reaps, D.....2000
 12—23. The Tin Can Shack, D.....1000
 12—28. When a Woman Waits, D.....2000
 12—30. The Unseen Vengeance, D.....1000
 1— 4. The Legend Beautiful, D.....2000
 1— 6. The Alarm of Angelon, D.....1000

BEAUTY

- 12— 8. Limping Into Happiness, C.....1000
 12—15. Her Younger Sister, D.....1000
 12—22. Brass Buttons, C.....1000
 12—29. Love Knows No Law, D.....1000
 1— 5. In the Vale of Sorrow, D.....1000

BRONCHO

- 12—16. The Panther.....
 12—28. The Passing of Two Gun Hicks....
 12—30.—Face on the Ceiling, D.....2000
 1— 6. Shorty the Prize Fighter, D.....2000

DOMINO

- 12—10. Not of the Flock.....2000
 12—17. The Political Feud.....2000
 12—24. The Last of the Line, D.....2000
 12—31. Flower in the Desert, D.....2000
 1— 7. The Scrub, D.....2000
 1—14. In the Land of the Otter, D.....2000

KAY-BEE

- 12— 4. Mother of the Shadows.....2000
 12—11. Fortunes of War.....
 12—18. The Game of Life, D.....2000
 12—25. In the Sage Bush Country, D.....2000
 1— 1. The Deadly Spark, D.....2000
 1— 8. A Midas of the Desert, D.....2000

KEYSTONE

- 10—26. Dough and Dynamite, C.....2000
 10—29. Gentlemen of Nerve, C.....1000
 10—31. Cursed by His Beauty, C.....1000
 11— 2. Lovers' Post Office, C.....1000
 11— 5. Curses They Remark'd, C.....1000
 11— 7. His Musical Career, C.....1000
 11— 9. His Trysting Places, C.....2000
 11—12. An Incompetent Hero, C.....1000
 11—14. How Heroes Are Made, C.....1000
 11—16. Fatty's Jonah Day, C.....1000
 11—19. The Noise of Bombs, C.....1 reel
 11—21. Fatty's Wine Party, C.....1 reel
 11—23. His Taking Ways, C.....1 reel
 11—23. The Sea Nymphs, C., special.....
 11—26. His Halted Career, C.....1 reel
 11—28. Among the Mourners, C.....1 reel
 11—30. Leading Lizzie Astray, C.....1 reel
 12— 3. Shotguns That Kick, C.....1 reel
 12— 5. Getting Acquainted, C.....1 reel
 12— 7. His Pre-Historic Past, special.....2 reels
 12— 7. Other People's Business, C.....1000
 12—10. The Plumber, C.....1 reel
 12—12. Ambrosio's First Falsehood, C.....1000
 12—14. Fatty's Magic Pants, C.....1000
 12—17. Hogan's Annual Spree, C.....1000
 A Colored Girl's Love, C.....1000
 12—21. Fatty and Minnie He-Haw (Special).
 2000
 1— 4. Hushing the Scandal (Special), C.....2000

KOMIC

- 12—27. The Record Breaker.....
 1—10. Love and Business, C.....1000
 1—17. Bill No. 15, C.....1000
 1—24. A Flurry in Art, C.....1000
 1—31. Cupid and the Test, C.....1000

MAJESTIC

- 12— 6. A Question of Courage.....
 12— 8. Her Brave Hero.....
 12—11. In Wildman's Land.....
 12—13. The Old Maid, D.....2000
 12—15. At Dawn.....
 12—20. In Fear of His Past.....2000
 12—22. The Better Way.....
 12—27. How Hazel Got Even.....2000
 12—29. Baby's Ride.....
 1— 5. His Lesson, D.....1000
 1— 8. Branch No. 37, D.....1000
 1—10. Three Brothers, D.....2000
 1—12. Probation, D.....1000

MUTUAL WEEKLY

- 11—10. No. 98.....
 11—17. No. 99, N.....
 11—26. No. 100, N.....
 12— 3. Weekly, No. 101, N.....
 12—10. No. 102.....
 12—17. No. 103, N.....1000
 12—24. No. 104, N.....1000
 12—31. No. 105, N.....1000
 1— 7. Weekly No. 106, N.....1000

PRINCESS

- 11—27. The Wild, Woolly West.....
 12— 4. The Creator of Hunger.....
 12—11. In the Conservatory, D.....1000
 12—18. Shadows and Sunshine, D.....1000
 12—25. The White Rose.....1000
 1— 1. When Fate Rebelled, D.....1000

RELIANCE

- 12— 2. The Lucky Shot.....
 12— 5. Who Shot Bud?.....
 12— 7. Our Mutual Girl, No. 47.....
 12— 9. Forest Thieves.....
 12—12. On the Ledge.....2000
 12—14. Our Mutual Girl, No. 48.....
 12—16. The Joke on Yelltown.....
 12—19. The Beat of the Year.....
 12—21. Our Mutual Girl, No. 49.....
 12—23. A Lucky Disappointment.....
 12—25. Bobby's Medal.....
 12—26.—The Exposure.....
 12—28. Our Mutual Girl, No. 50.....
 12—30. The Message.....
 1— 2. A Banakie Maiden, D.....1000
 1— 4. Our Mutual Girl No. 51.....1000
 1— 6. A Night Adventure, D.....1000
 1— 9. The Last Receipt, D.....2000
 1—11. Our Mutual Girl No. 52.....1000
 1—13. The Terror of the Mountain, D.....1000

ROYAL

- 11—21. Love Finds a Way.....
 11—28. Before and After.....
 12— 5. Sherman Was Right—It's Very Try-
 ing.....1000
 12—12. Percy the Milliner, C.....1000
 12—19. Two Kisses.....
 12—26. Her Mother's Voice.....
 1— 2. Putting It Over, C.....1000
 1— 9. Married by Installment, C.....1000

THANHOUSER

- 11—22. A Messenger of Gladness.....
 11—24. Mrs. Van Ruyter's Stratagem.....2000
 11—29. A Denver Romance.....
 12— 1. The Center of the Web.....2 R.
 12— 4. Naida, the Dream Woman.....
 12— 6. The Amateur Detective.....
 12— 8. The Reader of Minds.....2 R.
 12—13. When East Meets West.....
 12—15. The Barrier of Flames.....2 R.
 12—20. Sid Nee's Finish.....
 12—22. Under False Colors.....
 12—27. A Hatful of Trouble.....
 12—29. Lucy's Elopement.....
 1— 1. Shep the Sentinel, D.....1000
 1— 3. The Bridal Bouquet.....1000
 1— 5. The Menacing Past, D.....2000
 1—10. An Inside Tip.....1000
 1—12. The Speed King, D.....2000
 1—17. A Yellowstone Honeymoon.....1000
 1—19. Craft vs. Love, D.....2000
 1—24. The Dog Catcher's Bride, C.....1000

RELEASE DATES FOR READY REFERENCE — Continued

FEATURE RELEASES

ALCO FILM CORPORATION

ALL STAR

- 10-5. The Nightingale, D.....5 parts
10-19. Shore Acres5 parts
Nov. 23. Education of Mr. Pipp.....4 parts
Dec. 28. Garden of Lies.....4 parts

LIFE PHOTO FILM CORPORATION

- Dec. 7. Springtime
The Avalanche

POPULAR PLAYS AND PLAYERS

- 10-12. The Ragged Earl, D.....
10-26. Michael Strogoff, D.....5 parts
12-21. The Tigress

B. A. ROLFE PHOTO PRODUCTIONS

- Nov. Rip Van Winkle.....5 parts
The Three of Us.....
TIFFANY MOTION PICTURE CORP.
Heart of Maryland.....

ALLIANCE FILMS CORPORATION

COSMOS FEATURE FILM CORPORATION

- Lena Rivers, D.....5 parts
Nov. 30. Hearts and Flowers, D.....5 parts
The Little Girl That He Forgot.....

EXCELSIOR FEATURE FILM CO.

- The Path Forbidden.....
11-23. When Fate Leads Trump.....
The Under Trail.....

FAVORITE PLAYERS

- The Key to Yesterday.....5 parts
11-16. The Man Who Could Not Lose...
The Last Chapter.....

MASTERPIECE FILM COMPANY

- 11-9. The Hoosier Schoolmaster.....5 parts
12-14. The Truth Wagon.....5 parts

OZ FILM COMPANY

- 12-7. The Last Egyptian.....5 parts
SELECT PHOTO-PLAY PRODUCING CO.
10-26. At the Old Cross Roads, D.....5 parts

BOX OFFICE ATTRACTION CO.

BALBOA

- Nov. Little Jack3 reels
Nov. 10. Message of the Mind.....3 reels
Nov. 17. The Call of the Heart.....2 reels

NEMO

- Nov. Bitter Sweets.....3 reels

WHITE STAR

- Nov. The Mask2 reels
Nov. 10. To Love and to Hold.....2 reels
Nov. 17. Vengeance of the Flames.....3 reels

BOX OFFICE ATTRACTIONS—Special Features

- 11-9. Life's Shop Window.....
11-19. The Walls of Jericho.....
11-29. The Thief

BLINKHORN PHOTOPLAYS

- Nov. The Witness Invisible, D.....3 reels
Nov. The Aviator Traitor, D.....3 reels

COSMOFOTOFILM CORPORATION

- Nov. For Home and Country.....2 parts
Nov. She Stoops to Conquer.....4 parts
Nov. Called Back4 parts
Nov. Beauty and the Barge.....4 parts

ECLECTIC FILM COMPANY

- Nov. Pathé Daily News, No. 83, N.....1 part
Dec. The Silent Accuser, D.....3000
Dec. A Temperamental Whiffles, C.....2000
Dec. The Quality of Mercy, D.....2000
Dec. When Wealth Aspires.....4000
Dec. Star of Genius.....3000
The Perils of Pauline, D.....2 parts
The Secret of the Mountain, D., and Making
Sugar4 parts
The Bomb Boy, C.....3 parts
Whiffles Misses Mrs. Whiffles.....

ITALA FILM COMPANY

- Nov. Cabiria
Nov. Treasure of the Louzats.....4 parts
Nov. Jules Porel—Serpent.....3 parts

KINOTOPHOTE CORPORATION

- 10-26. Markia, or The Destruction of Car-
thage5 reels
11-2. Born Again5 reels
11-16. The Coming Power.....4 reels
11-23. The Spirit of the Poppy.....6 reels
12-7. The Span of Life.....5 reels
12-21. The Little Jewess.....4 reels

OZ FILM COMPANY

- Oct. Patchwork Girl of Oz.....5 parts

CONTINENTAL FEATURES

KAY BEE

- The Battle of Gettysburg.....

KEYSTONE

- Zu Zu, the Band Leader.....

MAJESTIC

- Ruy Blas

MUTUAL SPECIAL

- Mexican War Pictures.....
Seeing South America with Roosevelt.....

NEW MAJESTIC

- Sapho

N. Y. MOTION PICTURE

- The Wrath of the Gods.....

R & M

- The Great Leap.....
The Gangsters of New York.....
The Battle of the Sexes.....
The Floor Above
The Dishonored Medal.....
The Mountain Rat.....
Home, Sweet Home.....
The Avenging Conscience.....

THANHOUSER

- Moths
Robin Hood
A Legend of Provence.....
Frou-Frou
Joseph In the Land of Egypt.....
Cardinal Richelieu's Ward.....
Dope

PARAMOUNT PICTURES

BOSWORTH

- 11-23. The Country Mouse, C.D.....4 parts

SMALLEYS

- 12-17. False Colors, D.....5 parts
1-14. Aurora Leigh5 parts

COSMOFOTOFILM

- Dec. The Two Columbines.....2 parts
Dec. A Christmas Carol.....1 reel

FAMOUS PLAYERS

- 12-10. The Conspiracy4 reels
12-14. The Crucible5 reels
12-21. The Sign of the Cross.....5 reels
12-28. Cinderella5 reels
12-31. The Million4 reels
1-11. The Dancing Girl.....5 reels
1-18. The Morals of Marcus.....5 reels

JESSE LASKY COMPANY

- 12-7. Ghostbreaker, D.....5 parts
1-21. Young Romance5 reels
1-25. The Goose Girl.....5 reels

LASKY-BELASCO

- 1-4. The Girl of the Golden West.....5 reels

LASKY-LIEBLER

- 1-28. After Five5 reels

PICTURE PLAYHOUSE FILM COMPANY, INC.

- 12-2. Convict 555
12-10. Partners

SAWYER, Inc.

- Doc4 reels
The Envoy Extraordinary.....5 reels
Thais4 reels
The Fatal Night4 reels
The Virgin of the Rocks.....4 reels
Loves and Adventures of Shake-
spear6 reels
Saved by the Boys in Blue.....3 reels
King of the Bowery.....4 reels
Mona Darkfeather, Series2 reels
Nell of the Circus, Cecil Spooner.....4 reels
Spirit of the Conqueror.....5 reels
Catch of the Sword.....3 reels
Without Hope4 reels
As a Man Sows.....5 reels
A Factory Magdalen.....5 reels
The Lady of Lyons.....5 reels

UNITED FILM SERVICE
WARNER'S FEATURES, INC.

EVANS

- 11-27. Pagliacci, D.2000
12-7. Everyone, D.2000

FEATURES IDEAL

- 11-9. The Last Chord, D.....3000
11-16. The Nihilist's Daughter, D.....3000
11-25. Zandori's Secret, D.....3000
12-1. The Wolf's Prey, D.....3000

GAUNTIER

- 11-30. The Little Rebel, D.....2000

HUMANOLGY FILM PRODUCING CO.

- 12-7. The Price He Paid, D.....5000

LUNA

- 11-12. Reuben's Busy Day, C.....1 reel
11-19. Sage Brush Leading Lady, C.....1 reel
12-26. Soul Mates, C.....1000
12-2. Mountain Goat, C.....1000

MILLER BROTHERS

- 11-16. Rainbow's End, D.....3000
11-23. Mexican Hatred, D.....3000
11-30. Harvest Romance, D.....1000
12-7. Romance of Coyote Hill, D.....1000

MITTENTHAL

- 11-8. The Terror of a Great City.....3 reels

PREMIER

- 11-14. Gypsy's Warning, D.....1 reel
11-21. Bandit of Devil's Gap, D.....1 reel
The Prospector's Warning.....1 reel
11-28. As a Man Chooses, D.....1 reel
12-5. Prospector's Warning, D.....1 reel
12-5. Stung by a Bee, C.....1 reel

SAVOIA

- 11-8. The Last Chord.....3 reels

STARLIGHT

- 11-10. The Villain Still Pursued Her, C.....1 reel
11-15. Noisy Neighbors, C.....1 reel
11-23. Help! Murder! Police! C.....1 reel
12-1. Sadie as She Never Was, C.....1 reel

SUPERBA

- 11-8. Prince Charlie, C.....1 reel
11-15. Taste of High Life, C.....1 reel
11-23. Dr. Jekyll and Mr. Hyde, D.....1 reel
11-29. Camille as She Never Was, C.....1 reel

WARNER'S FEATURES

- Nov. Even Unto Death, D.....
Nov. The Serum of Reason.....4 parts

WORLD FILM CORPORATION

- 10-26. When Broadway Was a Trail.....5 parts
11-2. Across the Pacific.....5 parts
11-9. The Wishing Ring.....5 parts
11-16. One of Millions.....4 parts
11-23. Lola5 parts
11-30. The Dancer and the King.....5 parts
12-7. The Seats of the Mighty.....
12-14. The Marked Woman.....
12-21. As Ye Sow.....
12-28. The Pit
1-11. Wildfire

CALIFORNIA MOTION PICTURE CORP.

- 11-2. Salomy Jane5 parts
1-4. Mrs. Wiggs of the Cabbage Patch.....
1-18. Mignon4 parts
Lily of Poverty Flats.....
Salvation Nell.....



HANLON BROS.' "FANTASMA"



Fun
Beauty
Mystery



In
Five
Parts

Feature Spectacle of Beauty and Fun

Featuring George Hanlon, Jr., as the Clown

Released Saturday, December 19th, through the General Film Co. In 5 parts

Fantasma, the most famous spectacle and the greatest moneymaker ever produced by the celebrated Hanlon Brothers, makes even a better fantasy in the film than on the stage where it has been popular for 30 years. George Hanlon, Jr., of the famed family of clown and pantomimists, appears in his original role of Pico, the drollest clown that was ever created. W. T. Carleton, the greatest Mephisto on the American stage, plays Zamaliel, prince of Darkness and Evil, while George Schrode and William Ruge, celebrated in these parts, make the Imps a devilish pair. The lovely Marie La Manna graces the Princess role with fairylike charm.

For over thirty years Fantasma has fascinated all from the child to the grandfather with its wonderful blending of amusement and beauty, romance and fairyfolk, visualized as only the fancy of youth can picture.

The originators of this famous spectacle, Hanlon Brothers, were known over two continents as the greatest inventors of stage tricks, effects and illusions which they always used with bewildering beauty of effect. The Edison Company has preserved all the charm and atmosphere of the original production, adding new and surprisingly beautiful photographic effects never possible on the stage. Funniness, mystery, weird experiences, mystifying illusions and an unending panorama of gorgeous scenes in Fairyland are pictured with brilliant photography remarkable for color treatment.

Prince Arthur enraptured with the lovely Princess Lena wins her as his betrothed. But such bliss is not long for him, for Zamaliel, monarch of the infernal regions, sets his covetous eye upon the fair princess. Then ensues a mighty hattle between the Prince of Darkness and Fantasma, all powerful Queen of Good and Light, who watches ever over the lovers. The Princess, torn from her lover, is carried to the lower regions and then under the sea where weird and terrible trials beset her. The Prince is ever accompanied by the droll Pico in his wanderings in search for Lena and they undergo trials and wonderful experiences. The lovers, reunited, sail away at last on the Sea of Happiness—one of the most exquisite and original effects ever introduced into photography.

Fantasma, in thirty years, made ten millions gross. Book this greatest of features and cash in on its undying popularity and appeal.



TRADE MARK
Thomas A Edison
Makers of the Edison Kinetoscope, Model "D"

THOMAS A. EDISON, Inc.
275 LAKESIDE AVENUE
ORANGE, N. J.



RELEASE NOV. 23-rd

DIGBY BELL
in
THE EDUCATION OF MR. PIPP
(5 Parts)

—DECEMBER 28th—
JANE COWL
in
THE GARDEN OF LIES

All Star Feature Corp.
220 West 42d Street New York

YOU CAN BUY

Two color advertising space in

Accessory News

for

\$18.75

This Monday
and **Every Monday Thereafter**

GRANDIN FILMS

Featuring **Miss Ethel Grandin**
RELEASED THROUGH UNITED FILM SERVICE

Monday, Dec. 21st, **THE ADOPTED DAUGHTER** in Three Parts.
A gripping story of the underworld with Ethel Grandin in a dual role.

Monday, Dec. 28th, **CUPID KICKS A GOAL** Comedy Drama in One Reel

Monday, Jan. 4th, **THE BURGLAR** and **THE MOUSE** Comedy Drama in One Reel

Monday, Jan. 11th, **HIS DOLL WIFE** Comedy Drama in One Reel

EXHIBITORS ATTENTION!

We are spending thousands of dollars to help you get "big money" in YOUR box office with Grandin Films. Write us for list of exhibitor advertising helps. Trim your lobby with Grandin posters and display frames. Give your patrons Grandin souvenirs and prizes on the nights you show these pictures. Send for list of real money getting advertising matter prepared expressly for YOU.

Scenario Writers = We can use Two reel comedy dramas suitable for featuring Miss Grandin.

SMALLWOOD FILM CORPORATION
175 FIFTH AVENUE, NEW YORK, NEW YORK.

Ray C. Smallwood. D. Pres. & Sec. Arthur N. Smallwood Pres. & General Mgr.

SAVE 5 DAYS

Have your prints made and Shipped from

LOS ANGELES

Direct to your exchanges.

Process invented by an European cinema scientist, used exclusively in our plant, gives us extraordinary facilities for

—**SPEED**
—**DETAIL**
—**TINTING**
—**TONING**

Every print perfect.

Every order finished at the time promised.

INTERNATIONAL LABORATORIES

3123-25 So. Hoover St.,
Sunset Phone West 792
Los Angeles

LUBIN

LUBIN MASTERPIECES

Now Ready and About To Be Released
(Through the General Film Company)

EDWIN ARDEN
Drama By Edwin Arden IN **"EAGLE'S NEST"** Direction—Romaine Fielding

"THE DISTRICT ATTORNEY"
Drama By Charles Klein Direction—Barry O'Neil

"THE WHITE MASK"
FEATURING LILIE LESLIE
Drama By Clay M. Greene Direction—Joseph W. Smiley

ROSE COGHLAN
And **ETHEL CLAYTON** in
"THE SPORTING DUCHESS"
Comedy Drama By Cecil Raleigh Direction—Barry O'Neil

"THE COLLEGE WIDOW"
Featuring Ethel Clayton and George Soule Spencer
Comedy Drama By George Ade Direction—Barry O'Neil

"THE VALLEY OF LOST HOPE"
Drama By Shannon Fife Direction—Romaine Fielding

NOW SHOWING WITH SUCCESS (BY ARRANGEMENT WITH FRED MACE)
EVELYN NESBIT THAW and her son **RUSSELL WILLIAM THAW** in **"THREADS OF DESTINY"**
Drama By William H. Clifford Direction Joseph W. Smiley

SIX REGULAR RELEASES EACH WEEK **SPECIAL ONE, THREE AND SIX SHEETS**



"THE BELOVED ADVENTURER," Fifteenth of Series, "In Port O' Dreams"	{ Drama....Monday,	December 21
"HIS SUICIDE"	{ Split Reel Comedies.....Tuesday,	December 22
"FLOSSIE'S DARING LOYALTY"	{ Split Reel Comedies.....Wednesday,	December 23
"THE SINGLE ACT"—Two Reel Drama.....	Thursday,	December 24
"A SOLDIER OF PEACE"—Two Reel Drama.....	Friday,	December 25
"LURE OF THE GREEN TABLE"—Drama.....	Saturday,	December 26
"BRANNIGAN'S BAND"	{ Split Reel Comedies.....	
"A TROUBLESOME CAT"	{ Split Reel Comedies.....	



Lubin Manufacturing Company, Philadelphia, Pa. Chicago Office: 154 West Lake Street



Trinity of Triumphs

Progressive productions that will show the world what real motion pictures mean.

Beulah In Six Reels

Dramatization of Augusta J. Evans' famous American novel, in which the great Henry B. Walthall will be featured. Beulah will be a fitting sequence to St. Elmo, the smasher of highest box office records in all sections of the United States.

12 Vital Questions Of Life

Twelve 2 and 3 reel features, each a separate and distinct entertainment in theme, in treatment, in which Miss Ruth Roland, the famous "Kalem Girl," will be starred. Most wonderful dramatic achievements in the history of cinematography.

Ill-Starred Babbie In 4 Reels

Picturization of Will H. Whalen's heart story of the anthracite coal regions featuring

MISS JACKIE SAUNDERS
the fascinating "Balboa Girl"

Watch for other Sensational Announcements

Balboa Amusement Producing Company

H. M. HORKHEIMER
Pres. and Gen. Manager

E. D. HORKHEIMER
Sec. and Treasurer

"Makers of the Pictures Beautiful"

Studios and Executive Offices, LONG BEACH, CALIFORNIA



Quality

First!

600 LIVE NEWSPAPERS

and half a million dollars spent in advertising in those papers—your own local newspaper included, Mr. Exhibitor—will drive the people into your theatre and the

STANDARD PROGRAM

will keep 'em there day after day and week after week.

STANDARD PROGRAM

means exactly what it spells—a program of superlative quality—clean, wholesome, interesting, instructive and amusing pictures—pictures with the suggestive, the innuendo, the crime for crime's sake all cut out and the punch put in and fastened there by the best producers in the employ of the keenest manufacturers, with QUALITY FIRST, LAST AND ALL THE TIME!

MAKE YOUR ARRANGEMENTS NOW FOR THE

STANDARD PROGRAM

TO BEGIN JANUARY 18, 1915

STANDARD POLYSCOPE CORPORATION

WM. P. COOPER, President
115 BROADWAY

H. C. HOAGLAND, Gen'l M'g'r.
NEW YORK CITY

FOR INFORMATION REGARDING THIS NEW SERVICE
WRITE THE STANDARD PROGRAM ASSOCIATION

JOSEPH HOPP, Pres.
164 W. Washington St.
Chicago, Ill.

NELSON F. EVANS, Vice-Pres.
Commercial Bldg.
Cleveland, Ohio.

D. S. MARKOWITZ, Vice-Pres.
California Film Ex.
Los Angeles, Cal.

SAM'L WERNER, Treas., 14 N. Ninth St.,
St. Louis, Mo.

E. T. PETER, Secy., Dallas Film Corporation,
Dallas, Texas.

INCORPORATIONS

(Continued from page 51.)

NATIONAL MOVEMENT MOTION PICTURE BUREAU. General motion picture business; \$15,000; Manhattan. J. C. Cameron, A. Frankel and Catherine A. Doyle, of New York.

UNITED MOTION PICTURE COMPANY, INC.; \$10,000; Manhattan. Frederick Liegisl, Otto Rudolph, J. J. Lawrence, Jr., New York.

CYPRESS AMUSEMENT CO. Exhibiting motion pictures, etc.; \$3,000; Bronx. Patrick and Violet M. Meehan, Henry Knieriem and one other, of New York.

BISHOP, PESSERS AND LORIMORE, INC. Manufacturing motion pictures, etc.; \$10,000; New York. Thos. McMahon, Anna T. Heimburg and Alec Lorimore, of New York.

LUMEX MANUFACTURING COMPANY, INC.; General motion picture company; \$50,000; Manhattan. Wm. H. Griffin, V. H. Smith and James H. Miller of New York.

MURLEY AMUSEMENT COMPANY, INC. General amusement park, motion pictures, theatre, restaurant, etc., Brooklyn; \$5,000. T. F. Murphy and L. A. Kelly of Brooklyn, and William Numej of New York.

HOWE'S BROWNVILLE THEATRE COMPANY, INC. Exhibit moving pictures, etc.; \$1,000; Brooklyn. C. R. Frazer, E. A. Darr and W. M. G. Watson of New York.

MANUSCRIPTS UNIVERSAL SOCIETY OF WRITERS, INC. Theatrical, and act as authors in scenarios, etc.; \$20,000; New York. Anna T. Heimburg, T. F. McMahon and W. J. Lockhart of New York.

E. K. LINCOLN PLAYERS, INC. Motion pictures; \$25,000; Manhattan. Geo. Thoms, Theo Du Moulin, Jas. W. Bailey of New York.

JOS. WEBER PRODUCING COMPANY, INC. Theatrical and motion pictures; \$10,000; Manhattan. Max Weber, Dave Lewis and Phillip Friedman of New York.

C. L. CHESTER, INC. General photographic business, including moving pictures; \$5,000. C. Chester, W. C. Glass, E. M. McInnes of New York.

MOTION PICTURE STOCK EXCHANGE. Operate exchange and deal in stocks, bonds, etc.; dealing in motion picture or photographic films; \$1,000; Manhattan. E. B. Hesser, B. Naumburg and David Herman of New York.

SERIAL PUBLICATION CORPORATION. General publishing and motion picture business, operate theatres and amusement parks; \$5,000. Florence Lipnick, Geo. Trosk and Walter N. Seligberg of New York.

LE ROY PHOTO PLAY EXHIBITION CORPORATION. Proprietors and managers of theatres, give exhibitions of motion pictures; \$5,000; Brooklyn. Jacob B. Agins, Israel and Lena Hoffman of New York.

LLOYDS FILM RENOVATORS, INC. To clean and renovate moving picture films; \$1,000; Manhattan. B. J. Brown, G. R. Stevenson of New York, and Edna Weinburg of Brooklyn.

FICTION PICTURES, INC. Motion pictures, general photographic printing, etc.; \$25,000. Louis J. Vance, B. H. Stern and B. C. McKenna of New York.

CEDARHURST AMUSEMENT COMPANY, INC. Manufacturing theatres, open-air amusement parks, motion picture exhibitions, manufacturing of films, etc.; \$5,000; Cedarhurst. A. Kipp, Samuel W. Tannebaum and Chas. Schwartz of New York.

PHOTO PLAYERS PROPERTIES CORPORATION, Brooklyn. Manage theatres and motion picture exhibitions, etc. Capital, \$500,000. Incorporators: T. A. Kennedy, M. Beyer, C. Britton, Brooklyn.

COLOROGRAPH LABORATORY COMPANY. Operate moving picture laboratories, develop color photography. Capital, \$25,000. Incorporators: J. J. Atkinson, A. E. Osborn, Preston R. Myrick; attorney, Colorograph Laboratory, 683 Sixth avenue, New York City.

At Frankfort, Ky.:

Articles incorporating the **BLEICH AMUSEMENT COMPANY, Paducah, Ky.**, have been filed. The incorporators are R. E. Cooper, Odie Davis and C. H. Bleich. The corporation proposes to control a string of amusement places. The first of these, the Anderson theater, Anderson, S. C., will be opened February 1, 1915. Others will be added to the list.

THOROUGHbred FILM COMPANY, of Louisville, has filed amended articles of incorporation increasing the capital stock from \$50,000 to \$100,000. The stock has a par value of \$10 and is divided half in common and half in preferred. The amended articles were signed by J. Boyd, president, and four directors.

At Trenton, N. J.:

THE CRESCENT THEATRE COMPANY, having as its objects the building or leasing of theatres, moving picture houses, show houses, stores, shops, pool and billiard parlors, filed articles of incorporation in the County Clerk's office. The company has a capital stock of \$125,000, divided into 1,250 shares. Counselor C. Percy Hutchinson and Catherine Pipple each hold one share, while former Coroner John R. D. Bower

holds eight. It is believed the incorporators are acting for others.

At Wilmington, Del.:

TEMPO-FILM CORPORATION, Wilmington, Del. Capital stock, \$600,000. To carry on business of furnishing education, entertainment and amusement, for the general public. To exhibit dramas, plays, etc. Incorporators, W. G. Taylor, M. L. Rogers, Harry W. Davis, all of Wilmington, Del.

POPULAR MOTION PICTURE COMPANY. Manufacturing of films; conducting a general film exchange business. Capital, \$150,000. Incorporators: H. E. Latter, W. J. Maloney, O. J. Reichard, Wilmington.

At Springfield, Ill.:

MOTION PICTURES FIRE PREVENTION DEVICES COMPANY, Chicago. Manufacturing moving picture machine appliances. Capital, \$50,000. Incorporators: B. Samuels, S. Stenge, C. S. Wharton.

At Lansing, Mich.:

THE POPP MOTION PICTURE COMPANY, Wilmington, Del.; capital stock, \$10,000; to acquire, operate, manage and conduct a motion picture business and to do a general advertising business. Incorporators: William C. Popp, Francis M. Lane, James Saulsbury, all of Wilmington, Del.

THE REX THEATRE CO., of Flint, Mich., has incorporated for \$5,000.

THE ATLAS MOTION PICTURE COMPANY, of Detroit; capital, \$20,000, by Percy R. Upton and Charles G. Roos; to produce pictures.

At Sacramento, Cal.:

THE STANDARD FILM CORPORATION, San Francisco. Capital, \$50,000. D. S. Markowitz, M. A. Nathan, J. Brownstone, M. C. Hickey and L. E. Goodman.

PHOTOPLAYERS' STUDIO. Capital stock, \$6,000; subscribed, \$75. Directors: G. G. Wells, E. F. Vincent, Harry D. Naugle.

At Springfield, Ill.:

EUROPEAN WAR MOTION PICTURES COMPANY. \$10,000. John Prendergast, Ernest W. Kohlsaar, Henry L. Wilson.

ILLINOIS FILM CORPORATION, Chicago. To manufacture motion picture films. Capital, \$500. Incorporators: C. M. Williams, J. W. Brown and Charles P. McLaughlin.

At Indianapolis, Ind.:

I-K-M FILM CORPORATION, Indianapolis; \$100,000; to manufacture and deal in moving picture supplies. C. N. Stevenson, Harry Dunn, Henry R. Campbell.

WARNING

"All releases of Keystone films are now being copyrighted. All infringers and 'dupers' will be apprehended and punished to the extent of the law."

THE KEYSTONE FILM COMPANY

A. KESSEL, JR., President

Longacre Building, Broadway and 42nd Street

NEW YORK CITY

SPECIAL FEATURES

General Film Company

TITLE	MAKE	No. of Reels	TITLE	MAKE	No. of Reels
THIRD DEGREE	Lubin	5	IN TUNE WITH THE WILD.....	Selig	3
THOR, LORD OF JUNGLE.....	Selig	3	THE WOLF	Lubin	6
THE BATTLE OF SHILOH.....	Lubin	4	SHADOWS OF THE PAST.....	Vitagraph	3
THE LION AND THE MOUSE.....	Lubin	6	MR. BINGLES' MELODRAMA.....	Vitagraph	3
THROUGH FIRE TO FORTUNE.....	Lubin	5	MEN AND WOMEN.....	K. & E. Biograph 3	
JUDITH OF BETHULIA.....	Biograph	4	THE SECRET OF THE RING.....	Kleine	3
GERMINAL	Pathe	5	MY FRIEND FROM INDIA.....	Edison	3
LOST IN MID OCEAN.....	Vitagraph	3	LIBERTY BELLES	K. & E. Biograph 3	
A ROMANY SPY.....	Pathe	3	THE ERRING	Lubin	3
A CELEBRATED CASE.....	Kalem	4	AMBUSHED	Essanay	3
THE FULFILLMENT	Essanay	3	SONG OF THE SOUL.....	Kleine	3
NIGHT RIDERS OF PETERSHAM.....	Vitagraph	3	KIT, THE ARKANSAS TRAVELER.....	Kalem	3
HARDING'S HERITAGE	Pathe	3	CHIP OF THE FLYING "U".....	Selig	3
DAUGHTERS OF MEN	Lubin	5	FAIR REBEL	K. & E. Biograph 3	
THE OTHER HALF OF THE NOTE.....	Kalem	3	HOUSE NEXT DOOR.....	Lubin	5
HER LADYSHIP	Selig	3	MY OFFICIAL WIFE.....	Vitagraph	5
GOODNESS GRACIOUS	Vitagraph	3	UNCLE BILL	Vitagraph	3
OFFICER JIM	Lubin	3	THE FORTUNE HUNTER.....	Lubin	6
DEATH SIGN AT HIGH NOON.....	Kalem	3	THE VENDETTA.....	Kleine	5
GAME OF LIFE.....	Selig	3	BAREFOOT BOY	Kalem	3
THE MILITANT SUFFRAGETTE.....	Pathe	5	THE WIFE	K. & E. Biograph 3	
FRANCIS MARION, "THE SWAMP FOX".....	Kalem	3	KING OF CHANCE.....	Kalem	3
A MILLION BID.....	Vitagraph	5	THE WAGES OF SIN.....	K. & E. Biograph 3	
THE FATAL WEDDING.....	K. & E. Biograph 3		THE PLUM TREE.....	Essanay	3
THE GAMBLERS	Lubin	5	THE FIFTH MAN.....	Selig	3
ANNE BOLEYN	Kleine	3	THE GOLDEN BEETLE.....	Kleine	4
STRUGGLE FOR LIFE.....	Pathe	5	THE WEIGHT OF A CROWN.....	Lubin	3
MONGREL AND MASTER.....	Essanay	3	MARAH, THE PYTHONESS.....	Lubin	3
THE ROYAL BOX.....	Selig	4	CHARITY BALL	K. & E. Biograph 3	
THE CURSE OF CREED.....	Melies	5	HEARTS AND MASKS.....	Selig	3
FACING THE FOOTLIGHTS.....	Pathe	3	A FLORIDA ENCHANTMENT.....	Vitagraph	5
BLOOD WILL TELL.....	Essanay	3	ROAD TO YESTERDAY.....	K. & E. Biograph 3	
CONQUEST OF QUEBEC.....	Kalem	5	THE PAINTED WORLD.....	Vitagraph	3
THE LILY OF THE VALLEY.....	Selig	3	JUDGE NOT	Kleine	4
CLASSMATES	K. & E. Biograph 4		GARRISON'S FINISH	Selig	3
MAN OF THE HOUR.....	Selig	3	POWER OF THE PRESS.....	K. & E. Biograph 4	
MR. BARNES OF NEW YORK.....	Vitagraph	6	IN THE GLARE OF LIGHTS.....	Essanay	3
LOVE, LUCK AND GASOLINE.....	Vitagraph	3	THE RED CROSS NURSE.....	Melies	3
THE BILLIONAIRE	K. & E. Biograph 3		THE THREADS OF DESTINY.....	Lubin	5
SPORT AND TRAVEL IN CENTRAL AFRICA	Pathe	5	WHEN THE LIONS ESCAPE.....	Melies	3
THE GOOD FOR NOTHING.....	Essanay	4	THE GENIUS	K. & E. Biograph 3	
THE BOER WAR.....	Kalem	5	STONEWALL JACKSON'S WAY.....	Lubin	3
THE THUMB PRINT.....	Melies	4	THE INVISIBLE POWER	Kalem	4
STRONGHEART	K. & E. Biograph 3		THE WOMAN IN BLACK.....	K. & E. Biograph 4	
LORD CHUMLEY	K. & E. Biograph 4		UNDER THE GASLIGHT.....	K. & E. Biograph 4	
SEVEN DAYS	K. & E. Biograph 3		"413"	Vitagraph	
TREASURE OF ABDAR RAHMAN.....	Pathe	4	THE WIN(K)SOME WIDOW.....	Vitagraph	4
'NEATH THE LION'S PAW.....	Melies	3	THE STORY OF THE BLOOD RED ROSE.....	Selig	3
ONE WONDERFUL NIGHT.....	Essanay	4	THE TELL TALE HAND.....	Essanay	3
WOMAN AGAINST WOMAN.....	K. & E. Biograph 3		A POOR RELATION.....	K. & E. Biograph 3	
IN DEFIANCE OF LAW	Selig	3	THE LOCKED DOOR	Vitagraph	3
A KINGDOM AT STAKE.....	Kleine	3	THE TANGLE	Vitagraph	4
CAPTAIN ALVAREZ	Vitagraph	6	THE SPY'S FATE	Lubin	3
OTHELLO	Kleine	5	IN THE DAYS OF THE THUNDERING HERD	Selig	5
SHANNON OF SIXTH.....	Kalem	5	THE STRANGE STORY OF SYLVIA GRAY.....	Vitagraph	4
MAN'S ENEMY	K. & E. Biograph 3		THE BATTLE OF LOVE.....	Essanay	3
			FANTASMA	Edison	5
			THE SCHOOL FOR SCANDAL	Kalem	4
			THE HISTORY OF THE WORLD'S GREATEST WAR IN MOTION PICTURES.....	Selig	5

VITAGRAPH

"ARTHUR (TRUMAN'S WARD)" Drama **Monday, Dec. 21st**
Lillian confesses her deception. She is not his ward. He asks her to be his wife. **LILLIAN WALKER** and **DONALD HALL** are the leads.

"BY THE GOVERNOR'S ORDER" Two Part Christmas Drama **Tuesday, Dec. 22nd**
In the guise of Santa Claus an escaped convict sees his child. The Governor's pardon and her grandfather's forgiveness make Christmas a merry day. **MAURICE COSTELLO** in the lead.

"THE PROFESSOR'S ROMANCE" Comedy **Wednesday, Dec. 23rd**
He wants the widow, but don't want her children. Some funny things happen before he consents to become their step-father. **SIDNEY DREW** as the Professor.

"THE KNIGHT BEFORE CHRISTMAS" Juvenile Story **Thursday, Dec. 24th**
"Sommy Jim" practices the Christmas spirit. He is heralded as a Knight of good deeds and a princely little fellow. **BOBBY CONNELLY** as the Knight.

"SWEENEY'S CHRISTMAS BIRD" Comedy **Friday, Dec. 25th**
It leads to a terrible row. The combatants forget the past and make merry at the Christmas feast. **HUGHIE MACK, FLORA FINCH, WILLIAM SHEA,** and **KATE PRICE** take part in it.

"AN AFFAIR FOR THE POLICE" Two Part Comedy **Saturday, Dec. 26th**
A clever woman proved she could outwit them. Everybody has to laugh when she shows them how easy it was. **LEAH BAIRD** and **LEO DELANEY**, principals.

SIX A WEEK
"THE PRODUCT," Drama **MONDAY, DEC. 28**
"THE PLOT," Two Part Drama **TUESDAY, DEC. 29**
"FORCING DAD'S CONSENT," Comedy **WEDNESDAY, DEC. 30**
"LOVE WILL OUT," Comedy-Drama **THURSDAY, DEC. 31**
"AUNTIE'S PORTRAIT," Comedy **FRIDAY, JAN. 1**
"IN THE LATIN QUARTER," Two Part Drama **SATURDAY, JAN. 2**

VITAGRAPH ONE, THREE AND SIX SHEET POSTERS

The Vitagraph Company of America
East 15th Street and Locust Avenue, Brooklyn, N. Y.

BROADWAY STAR FEATURES

LISTED AND RELEASED

A Million Bid	5 Parts	A Florida Enchantment	5 Parts
Goodness Gracious	3 Parts	413	3 Parts
Mr. Barnes of N. Y.	6 Parts	The Win(k)some Widow	4 Parts
Love, Luck and Gasolene	3 Parts	The Tangle	4 Parts
Captain Alvarez	6 Parts	The Locked Door	3 Parts
Shadows of the Past	3 Parts	Sylvia Gray	4 Parts
Mr. Bingles' Melodrama	3 Parts	The Little Angel of Canyon Creek	5 Parts
My Official Wife	5 Parts	Two Women	3 Parts
Uncle Bill	3 Parts	The Sage Brush Gal	3 Parts
The Painted World	3 Parts		

COMING FEATURES

4-Part Comedy THE MAN BEHIND THE DOOR From A. C. Gunter's Story	3-Part Drama UNDERNEATH THE PAINT With Helen Gardner and Strong Cast
4-Part Comedy C. O. D. A Wonderful Screen Version of Frederick Chapin's Laughing Story	4-Part Comedy HOW CISSY MADE GOOD With Cissy Fitz-Gerald, Flora Finch and Entire Stock Company.

For terms and particulars apply

GENERAL FILM COMPANY'S SPECIAL SERVICE

By Arrangement With BROADWAY STAR FEATURE CO., (Inc)



'TIS A MYSTERIOUS THING!

Better Write Now

Book It Later

EDWIN AUGUST

Master Actor of the Films

is producing IT for the

KINETOPHOTE

AND it is going to be the best box-office attraction ever put out. It will mystify you; it will mystify your audience.

IF your competitor gets it for your district it is all off. Nothing can stop him.

ASK ABOUT IT NOW

Feature



Productions

TELEPHONE *6072 BRYANT

NEW YORK CITY

126-132 WEST 46TH STREET



VITAGRAPH

NEW POLICY ^{FO} THE NEW YEAR

SPECIAL ARRANGEMENT HAS BEEN MADE WITH THE BROADWAY STAR FEATURE COMPANY TO RELEASE

ALL THE THREE-PART BROADWAY STAR FEATURES IN THE REGULAR GENERAL FILM SERVICE

EVERY ALTERNATE TUESDAY and EVERY ALTERNATE SATURDAY

"TWO WOMEN" TO BE RELEASED TUESDAY, JAN. 5th

"THE SAGE BRUSH GAL" TO BE RELEASED SATURDAY, JAN. 16th

RECEIVED THE HIGHEST PRESS ENDORSEMENTS AND MADE THE BIGGEST KIND OF HITS AT THE VITAGRAPH THEATRE

"TWO WOMEN"

"Such Plays are an unusual occurrence."—DRAMATIC MIRROR.
"The soul adventures of Two Women."—NEW YORK AMERICAN.
"A powerful drama of Life."—TELEGRAM.
"A virile Drama."—EVENING SUN.

"THE SAGE BRUSH GAL"

"The story might have been written by Bret Harte."—DRAMATIC MIRROR.
"Drama, strong and heart-stirring."—NEW YORK AMERICAN.
"Picture Play with a 'Punch.'"—VARIETY.
"A vivid picture of the early '50's."—EVENING SUN.

THE VOICE OF THE PRESS IS THE VOICE OF THE PEOPLE



ANITA STEWART AND EARLE WILLIAMS IN "TWO WOMEN"



THE SAGE BRUSH GAL

CARTOONS FROM THE N. Y. AMERICAN



COSMOS

FEATURE FILM CORP.
NEW YORK



PRESENTS

BEULAH POYNTER

IN HER OWN
PLAY

The Little Girl that He Forgot

IN
5 PARTS

HER GREATEST
DRAMATIC SUCCESS



STATE RIGHTS BUYERS

ADDRESS

COSMOS FEATURE FILM CORP.

128 W. 46TH ST. NEW YORK CITY

Mary Pickford Joins New York Motion Picture Corporation

It may be stated on positive authority that Mary Pickford is to be identified with the New York Motion Picture Corporation. Definite announcements will be shortly forthcoming from that company, in which not only Miss Pickford's name, but those of other equally notable stars will figure. In view of the recent statement in Motion Picture News that Ad Kessel had taken over the Willat Studios at Fort Lee, N. J., the engagement of Mary Pickford and other stars is doubly significant.

This disposes of the numerous rumors concerning Mary Pickford's activities.

NASH SIGNS WITH KRITERION

Managing Director A. M. Kennedy, of the Santa Barbara Motion Picture Company, spent a portion of last week in Los Angeles visiting studios of the companies producing for the Kriterion program of the Mica Film Corporation.

The Jesse Robbins Photo Play Company will not take part in making subjects for this company. The Nash Motion Picture Company, which makes wild animal subjects at the Big Otto Zoo, east of Los Angeles, have been secured for Sunday feature releases and a contract made with them for one two-reel drama weekly, beginning with the first week of the service. This company is under the direction of Thomas S. Nash, for 17 years with the Selig Poloscope.

Chaplin Goes to Essanay; Neilan Will Leave Kalem

Special to MOTION PICTURE NEWS

Los Angeles, Dec. 17.

The following important changes are authoritatively announced for the new year:

Charles Chaplin leaves Keystone for Essanay to direct comedies and play leads.

Marshall Neilan, director-general of Kalem Hollywood studios, will go to Lasky for "The Country Boy" and then join Famous Players.

Ford Sterling will return to Keystone, according to an unconfirmed rumor.

J. C. JESSEN.

A. P. F. FILM CO., PRESENTS

The Favorite Photo Play Star

MR. ALBERT PRISCO

With an All Star Cast In

THE GREAT MYSTERIES OF NEW YORK

5 PARTS

COPYRIGHT 1914

CAST OF 400

State right buyers write, wire or call. Procure this wonderful production and money getter. It's the Feature of Features, masterful in its every detail. Mr. Moving Picture Manager, we handle New York and Greater New York ourselves. Theatres can book direct from us. This film means a line at your box office window. Write, call or wire.

DO NOT LOSE ANY TIME. GET BUSY AND COMMUNICATE WITH US. ADVERTISING MATTERS IN ALL LANGUAGES. We have the best line of advertising you ever saw. 1-3-6 sheet posters, heralds, slides, lobby photos and frames.

A. P. F. FILM CO.

110 West 40th St., World Tower Bld.

Suite 602

Phone Bryant 3028



FAVORITE PLAYERS FILM COMPANY

PRESENT

"THE MAN WHO COULD NOT LOSE"

A Five Part Photo Play From the Book By RICHARD HARDING DAVIS

Previously Released
THE KEY TO YESTERDAY

Executive Offices:
110 W. 40th St., N. Y. C.

Released Through The
ALLIANCE FILM CORP.

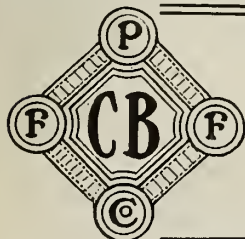

BOOK
WHEN FATE LEADS TRUMP
(Four Parts)

EXCELSIOR

FEATURE FILM COMPANY, INC.

110 WEST 40th STREET, NEW YORK CITY

BOOK
THE PATH FORBIDDEN
ALLIANCE PROGRAM

THE ALBUQUERQUE FILM MFG. COMPANY, Inc.

Featuring that clever
Comedienne

Miss Dot Farley

Two Comedies Weekly

RELEASING THROUGH
The United Motion Picture Producers, Inc.
WHO DISTRIBUTE THROUGH
Warner's Features, Inc.

By request from many exchanges
we take pleasure in
reviving the

FRONTIER TWIN STORIES

Written and made famous by Miss Dot
Farley. Under direction of
Gilbert P. Hamilton

Farce Comedy Production
BY

ARCHER McMACKIN

Nuf Sed

WESTERN STUDIO

406 Court St. Los Angeles, Calif.

GILBERT P. HAMILTON, Pres. and Gen. Mgr.

ALL-STAR REORGANIZES; GAIGE PRESIDENT, FARNHAM A DIRECTOR

AT a meeting of the directors of the All-Star Corporation held December 12 Crosby Gaige, of Selwyn & Company, was elected president in the place of Harry Raves, resigned. Mr. Gaige was also elected a director.

Joseph White Farnham was elected a director and made general manager of the corporation. Mr. Gaige becomes director general in place of Augustus Thomas, resigned, and together with Charles Klein, the eminent dramatist, will direct future All-Star productions. Mr. Klein, who assists in a consulting capacity over scenarios and productions, leaves on December 23 for Europe to open negotiations for All-Star with several eminent English and Continental authors.

The other officers of the company remain as before: Archibald Selwyn, of Selwyn & Company, vice-president; Philip Klein, treasurer, and George Cook, secretary. Mr. Cook's stock has not been sold despite rumors to the contrary.

As stated in last week's issue of the MOTION PICTURE NEWS Harry Raver and Augustus Thomas disposed of their holdings in All-Star and resigned as officers of the corporation. Their stock was purchased by Attorney Griffith, acting for John Dunlop, president of the Alco Film Company.

MEETING CALLED FOR NEW YORK EXHIBITORS

A CALL has been issued for a meeting of the exhibitors of New York State under the auspices of the Motion Picture Exhibitors' League of America, to be held in an up-state city, the name of the city to be announced later.

President Pearce of the League will preside at the session. The present officers of the New York body will be asked to resign.

The conference will be held primarily for the purpose of devising ways and means to further the business interests of all exhibitors. The meeting will be free from "politics." Those behind the movement intend with the welfare of the motion picture managers and owners at heart to make the occasion a strictly business meeting.

Committees of able business men will be appointed for the investigation of laws burdening exhibitors and objectional bills pending before the legislature.

Further discussion will be devoted to the formation of plans helpful to theatre proprietors in regulating their affairs.

The secretary will be instructed to collect data pertaining to the prices of features and other matters of importance.

The workmen's compensation law which has entailed upon motion picture managers the burdensome insurance of employees will receive its share of discussion at the meeting.

The benefits derived from the meeting by exhibitors who attend will equal ten times their association dues; e. g., feature prices alone, to say nothing of other important interests.

EDISON FILM SERVICE UNDISTURBED BY FIRE

THE loss sustained by Thomas A. Edison, Inc., as a result of the fire of the night of December 9 at the plant in West Orange, N. J., will be considerably less than \$1,000,000, officials of the company are now confident.

The fire did not start in the film plant; in fact this was the last to go. So much time elapsed between the start of the fire and the burning of the film plant that all of the negatives for the current and coming releases were saved, including "Fantasma," the Edison five reeler.

The Edison film releases will not be impaired at all. The company, by using the facilities of the kinetophone plant (Edison talking pictures), have already completed 200,000 feet of film, which was the normal output of the original plant.

The only branch of the industry that will suffer from the fire is the projection department, and even this will be working to normal capacity by spring. There will probably be a delay of two or three months in the output of Edison's kinetoscope.

MANAGER'S SCREEN REPORTS

Furnishing typewritten reports on the quality and character of extra price features prior to release date. Low introductory rates open for short time only. Address:

MANAGER'S SCREEN REPORTS
E. V. Morrison & Harry H. Poppe, Operators
808 Times Building, New York City



THE VICTIM



THE OTHER GIRL



THE PRICE HE PAID

Every one of its hundreds of scenes, from the simplest to those of tremendous emotional intensity, shows the touch of the master hand of

Ella Wheeler Wilcox

in five heart-gripping parts. Now ready for booking. Write your nearest United Exchange

UNITED FILM SERVICE (WARNER'S FEATURES INC) N.Y.

A Suggestion to Exhibitors

When a new so-called "program" is offered to you, get answers to the following questions:

Is there a year's preparation back of it?

Have \$2,500,000 been expended to insure its absolute permanency?

Have 40 or more exchanges been established to handle it?

Has there been an organization of big producing companies formed and incorporated to supply it?

Only one service established during the past year can answer "yes" to any or all these questions—the

UNITED FILM SERVICE

That is why the United Film Service is today an accomplished fact—serving exhibitors throughout the country with daily releases of comedies and dramas in single and multiple reels.

Get in touch by mail or telephone with your nearest United Film Service exchange and ask for full information.

UNITED FILM SERVICE (Warner's Features, Inc.) **New York**

THROUGH SHADOWS TO SUNSHINE



The stirring story of a girl who is falsely accused and hounded from place to place until hope is almost gone. A great two-part feature --- one of the daily releases of single and multiple reel pictures by the United Film Service.

UNITED FILM SERVICE (WARNER'S FEATURES, INC.) N.Y.

Stars on the Alliance Programme



OCTAVIA HANDWORTH



MRS. THOMAS WHIFFEN



CARLYLE BLACKWELL



BOBITA ROBERTSON



MAX FIGMAN



ESTHA WILLIAMS



J. FARRELL McDONALD

WE ARE SPECIALISTS

In Feature Photoplays of the Highest Type
Made by Leading American Producers
Written by Celebrities of the Literary World
Featuring Stars of National Reputation

ALLIANCE FILMS CORPORATION
130 WEST 46th ST. N.Y.

CARLYLE BLACKWELL
in
THE LAST CHAPTER

In Five Parts

By **RICHARD HARDING DAVIS**

Produced by Favorite Players Film Co., Released Dec. 21.

THE TRUTH WAGON

From the play by Hayden Talbot
with MAX FIGMAN

THE MAN WHO COULD NOT LOSE

By Richard Harding Davis
with CARLYLE BLACKWELL

HEARTS AND FLOWERS

From the celebrated play of the same name
with MRS. THOMAS WHIFFEN

THE KEY TO YESTERDAY

From the Novel by Charles Nevil Buck
with CARLYLE BLACKWELL

THE LAST EGYPTIAN

From the book by L. Frank Baum
with FARRELL McDONALD and VIVIAN REED

WHEN FATE LEADS TRUMP

From Novel by Alice M. Roberts
with OCTAVIA HANDWORTH

THE HOOSIER SCHOOLMASTER

From the great American Story by Edw. Eggleston
with MAX FIGMAN

THE PATH FORBIDDEN

From the Novel by John Hymer
with OCTAVIA HANDWORTH

AT THE OLD CROSS ROADS

From Arthur C. Aiston's famous play
with ESTHA WILLIAMS

EXCHANGES

ALLIANCE FILM SERVICE, 115 Fourth Ave., Pittsburgh, Pa. A. A. Welland, Mgr. *Ohio, Western Pennsylvania, Kentucky and West Virginia.* (Kentucky exhibitors will be served from Cincinnati office after Dec. 1.)

ALL THEATRES, FILM AND ACC. CO., INC. Owners of Alliance Film Exchanges, New York State. Buffalo Office, 18 Chapin Block; S. S. Webster, Mgr.; I. Cobe, Gen. Rep. New York City Office, 126 West 46th St.; M. F. Toblas, Mgr.

ALLIANCE FILM SERVICE, controlled by Eastern Feature Film Co., Inc., 57 Church St., Boston, Mass. *New England.*

ALLIANCE FEATURE FILM SERVICE, controlled by Mecca Feature Film Co., 130 West 46th St. *Northern New Jersey.*

ELECTRIC THEATRE SUPPLY CO., Vine and 13th St., Phila., Pa. *Southern New Jersey, Eastern Pennsylvania, Maryland, Delaware, District of Columbia, Virginia.*

CASINO FEATURE FILM CO., Dime Savings Bank Bldg., Detroit, Mich. *Michigan.*

ALLIANCE FILM CO. OF TEXAS, 1905½ Commerce St., Dallas, Tex. *Texas, Oklahoma, Louisiana and Arkansas.*

HYBAR FILM CORP., Forsythe Bldg., Atlanta, Ga. *Georgia, Alabama, Mississippi, Tennessee, Florida, North and South Carolina.*

CELEBRATED PLAYERS FILM CO., 64 West Randolph St., Chicago, Ill. *Illinois and Indiana.*

NAT A. MAGNER CO., Pacific Bldg., San Francisco, Calif.; 218 Superba Theatre Bldg., Los Angeles, Calif. *California, Nevada and Arizona.*

DES MOINES FILM SUPPLY CO., 218 Utica Bldg., Des Moines, Ia. *Iowa.*

MONARCH FEATURE FILM CO., 12th and Wyandotte Sts., Kansas City, Mo. *Missouri, Kansas and Nebraska.*

ZENITH FEATURE FILM CO., Lyceum Bldg., Duluth, Minn. *Minnesota, North and South Dakota and Wisconsin.* Milwaukee Office, 407 Manhattan Bldg.

ALLIANCE FILM SERVICE, Controlled by Noted Players Feature Film Co., 613 New Birks Bldg., Montreal. Jas. D. Goldie, Gen. Mgr., *Canada.*

ALLIANCE PROGRAMME FEATURE SERVICE. Exchanges located at 710 Northwestern Bank Bldg., Portland, Ore.; 1214 Third Ave., Seattle, Wash.; 809 Trent St., Spokane, Wash.; 27 N. Park St., Butte, Mont.; 607 Ideal Bldg., Denver, Col. Supplying States of *Washington, Montana, Oregon, Idaho, Wyoming, Colorado, Utah, and New Mexico.*

ALLIANCE FILMS CORPORATION
130 WEST 46th ST. N.Y.

THE MASTERPIECE FILM MFG. CO.
 PRESENTS
MR. MAX FIGMAN

SUPPORTED BY
 MISS LOLITA ROBERTSON *in*
The **TRUTH WAGON**
 (5 REELS)



A comedy-drama adapted from the play
 BY HAYDEN TALBOT

Produced under the personal direction of
 Mr. Figman, who collaborated with Mr.
 Talbot in the writing of the play, and
 for whom the play was especially written

RELEASED ON ALLIANCE PROGRAM

MASTERPIECE FILM MFG. CO.

1111 Van Nuys Bldg.

Los Angeles, Cal.

MAX FIGMAN, General Director

WESTON

**WHAT DO
YOU NEED
AS AN
EXHIBITOR
?**

- Accurate Release Pages?
- Exhaustive Reviews?
- Money-Making "Live-Wire" Hints?
- Helps on Projection?
- Idea-Inspiring Features?
- Eye-Opening Construction Articles?
- Musical Advice by Practical Musicians?
- Exhibitors' League News?
- Last Minute Information on Everything?

ALL THIS AND MORE

MOTION PICTURE NEWS

**IS OFFERING YOU
IN EVERY ISSUE—EVERY WEEK**

- Five pages of the most complete release charts to be had—
- Ten to fifteen pages of film reviews—
- Fifteen pages devoted solely to equipment and accessories—
- The news of the trade classified and arranged to meet your busiest moments—

**YOUR EVERY NEED ANTICIPATED AND
MET BY MEN WHOSE BUSINESS IT IS
TO KNOW THEM**

*Can you afford to be
without such a Trade
Journal?*

CUT HERE AND MAIL TODAY

**MOTION
PICTURE
NEWS**

220 West 42d St.
New York City

Enclosed find Two Dol-
lars (\$2) in payment for
one year's subscription to
MOTION PICTURE NEWS,

beginning with the.....

..... issue

Name

Theatre

City..... State.....

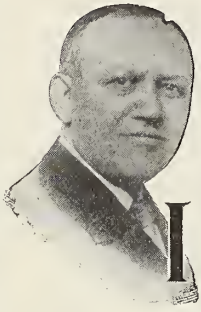

Smashing An Idol

(No. 62. Straight-from-the-Shoulder Talks by Carl Laemmle, President.)

I HAVE no patience with an exhibitor who tells me that he can go to such and such an exchange and "get 30-day old film for less money than the Universal charges." Nor have I any patience with the exhibitor who tells me he can "get 20-day old film for less money than the Universal asks for 60-day film."

The exhibitor who figures on the age of film and nothing else will never get anywhere. There's only one thing he ought to take into his calculations, and that thing is quality of production.

The people at large don't know **AND DON'T CARE** whether a film was released ten days ago or ten weeks ago, but you can't fool them on quality. They know mighty well **WHETHER A PICTURE IS GOOD OR BAD**. They would rather have a good picture, even though it was released three months ago, than a poor one "right out of the can."

The average exhibitor has made a little tin idol out of the question of age. He spends more time quibbling with his exchange about the age of a picture than he does in making dead sure of quality.

If Mr. and Mrs. John Jones and their family live in your vicinity, you ought to care more about pleasing Mr. and Mrs. John Jones than yourself. If Mr. and Mrs. John Jones have never had an opportunity to see certain **GOOD** pictures, because they were never shown in your vicinity, you ought to give them the opportunity. What do they know or care about the date when the film was first released?

If the pictures are good and the film in good condition, Mr. and Mrs. John Jones will get their money's worth, and they will pay you just as much money to get into your theatre as they would if the film had never been shown anywhere else on earth before.

I maintain that Universal films at 30, 60, 90 or 120-days or any other age (as long as they are

in good physical condition) are better than any pictures you can get from any other source, even though the latter are first run.

While practically all other concerns are retrenching "on account of the war in Europe," the Universal is pouring more money than ever into scenarios, settings and all other departments of the business. We are reaching out for the best things that money can buy **AND WE'RE GETTING THEM**.

Which would you rather have, a "first run" picture made by a concern that is skimping on its product or a one-hundredth run picture made by a concern that is spending cash right and left and leaving nothing undone to give the people the best pictures on earth?

The time for thinkers is here. The time to smash the old idols and break the old film habits is here. The time to buy quality and not service is here.

The Universal program will probably cost you **MORE MONEY** than any other program represented in your territory. But it will just as surely **MAKE YOU MORE MONEY** because it is based on the solid rock of quality and not on the shifting sands of cut-prices. It insures your future while building up your present.

If you are determined to scrap with your exchange, at least don't tell him you can get 30-day film somewhere else for less money than he asks. He knows it. And he also knows that the stuff you can get elsewhere is **WORTH A WHOLE LOT LESS THAN UNIVERSAL GOODS**. He is not going to bid for your business by means of cut prices. He has the best program on earth to offer you. He asks a fair price for it.

Quit thinking age. Think quality. Take the old idol from its place in your thoughts. Give it a swift smash in the eye. It will leave just that much more room in your brain for **REAL BUSINESS THINKING!**

CARL LAEMMLE.

Accessory News

A SECTION OF MOTION PICTURE NEWS DEVOTED TO THE
CONSTRUCTION, EQUIPMENT AND OPERATION OF THE MODERN PICTURE THEATRE

The Rex Film Renovator

It is now operating in the following Warners Features, Inc.,
offices, located at

Warners Features, Inc., 126 W. 46th St., New York City.

- " " " 445 S. Warren St., Syracuse, N. Y.
- " " " 17 No. Wabash Ave., Chicago, Ill.
- " " " 360 St. Catherine St., W., Montreal, Can.
- " " " 212. Columbia Bldg., Cleveland, Ohio.
- " " " Soon to be installed, New Orleans, La.

and twenty-one other Universal and Mutual offices.

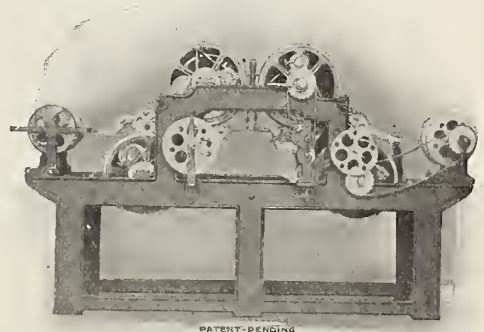

Mr. Exhibitor, when contracting service, ask if the exchange
has a REX RENOVATOR and be sure you get a service free from
rain. Rainy film is damaging to your business.

Ask about the MIDGET CLEANER and SILENT REWINDER.
You'll eventually get it.

Write for booklet, "Creating Good Will"; it also has a good
Film Cement Formula.

The Rex Film Renovator Mfg. Co.
272 N. Third Street
Columbus, Ohio

WE RENOVATE FILM. WRITE FOR PRICES

DON'T BE MISLED

THE LATE MODEL **MOTIOGRAPH** EQUIPMENT approved by The National Board of Fire Underwriters, is the **BEST** Projecting Machine on earth.

We invite you, Mr. Buyer, to "check up" the **MOTIOGRAPH** statement—that you will get more real and actual value in one **\$250.00 MOTIOGRAPH** than in two machines of any other make, even when they are higher priced.

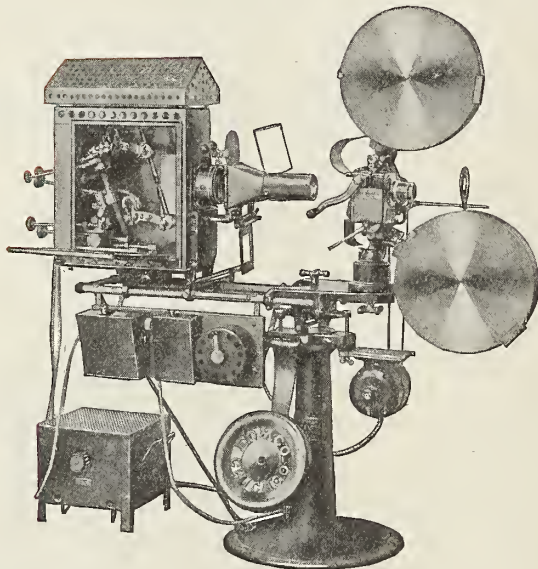

The **Motiograph** ground and hardened parts are in a class by themselves and not to be compared with those heavily advertised machines made of soft parts.

Mr. Owner — you cheat yourself when you ignore **MOTIOGRAPH QUALITY**. Besides,

you know the price is lower and the **MOTIOGRAPH** projection is far superior in brilliancy, in detail and definition. Further, you are cheating your patrons who pay for these features.

Think it over and make a New Year's resolution that you will give your patrons the **BEST** pictures by buying the **BEST** projector—The **MOTIOGRAPH**.

(Write for *Motiograph Literature*)

THE ENTERPRISE OPTICAL MFG. CO.

568 West Randolph Street, Chicago

EASTERN OFFICE: 19 West 23rd Street, New York

WESTERN OFFICE: 833 Market Street, San Francisco

Construction,
Equipment
and Operation

Accessory News

Everything for
the Modern
Picture Theatre

TEL. 7650 BRYANT

TWO HUNDRED AND TWENTY WEST FORTY-SECOND STREET

NEW YORK CITY

Volume X

DECEMBER 26, 1914

Number 25

Increasing a Theatre's Usefulness

BUILDING activity on the Pacific coast following the general revival of business, will probably result in the construction of numerous photoplay theatres planned with the idea of making them the social centers of the communities.

The structures will have two or three floors if properly planned. The upper part of the buildings will be arranged for the use of local entertainments—lodge meetings, balls and other gatherings interesting the townspeople and their friends in the nearby region. In some cases bowling alleys could be installed in the basements.

In the case of comparatively small communities buildings of this character should become the logical centers of a town's social activity. The opportunities for diversion afforded by an arrangement of this kind make a unique combination of strong drawing power.

In advertising alone a motion picture theatre situated in a building like this will have unusual advantages over competing houses. People attending a dance on the upper floor, on their way to a lodge meeting, or going to the alleys to while away the evening in a game, must all pass the theatre lobby, and may be reminded of the more interesting form of entertainment going on inside.

In some cases the posters and the sound of the music floating through the doorway may divert the pleasure seekers from their original purpose. At least the reminder would probably serve to bring them back to the theatre the next night.

Theatre Possessing Numerous Advantages

A theatre embodying all these features is the Globe, Palos Verdes street, San Pedro, Cal. The building on account of its completeness and up to date furnishing has attracted wide at-

tention, and is a tribute to the originality of its designers, Lawrence B. Valk and A. Lawrence Valk, of Los Angeles, architects, who make a specialty of motion picture theatres.

Besides the theatre on the ground floor, the Globe has a ball and lodge room on the second story, and in the basement there is a bowling alley and pool and billiard parlor. The life of the whole town practically revolves around the building,

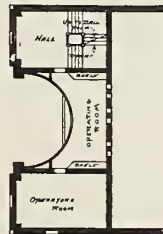

PLAN OF SECOND FLOOR

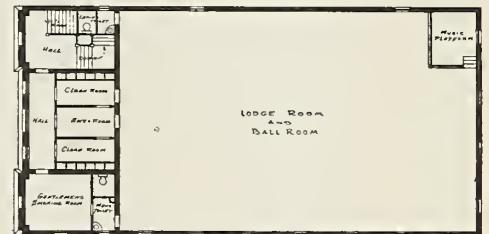

GLOBE THEATRE BUILDING NO. 5
ARCHT. BY L. B. & A. L. VALK, SAN PEDRO, CALIF.

L. B. & A. L. VALK,
THEATRE SPECIALISTS
LOS ANGELES, CAL.

and the inhabitants cannot help bearing in mind the Globe and its wide scope of attractions.

Great credit is due the foresight of the architects, who, realizing the possibilities of a small-town theatre built along these lines, worked out their plans with a daring originality justified by the success enjoyed by the Globe. For over a year the house has been conspicuous among theatres for its uninterrupted prosperity. As this combination plan has thus been tried out and the expense of erecting such a building is justified, it deserves to be imitated elsewhere.

(Continued on page 110.)

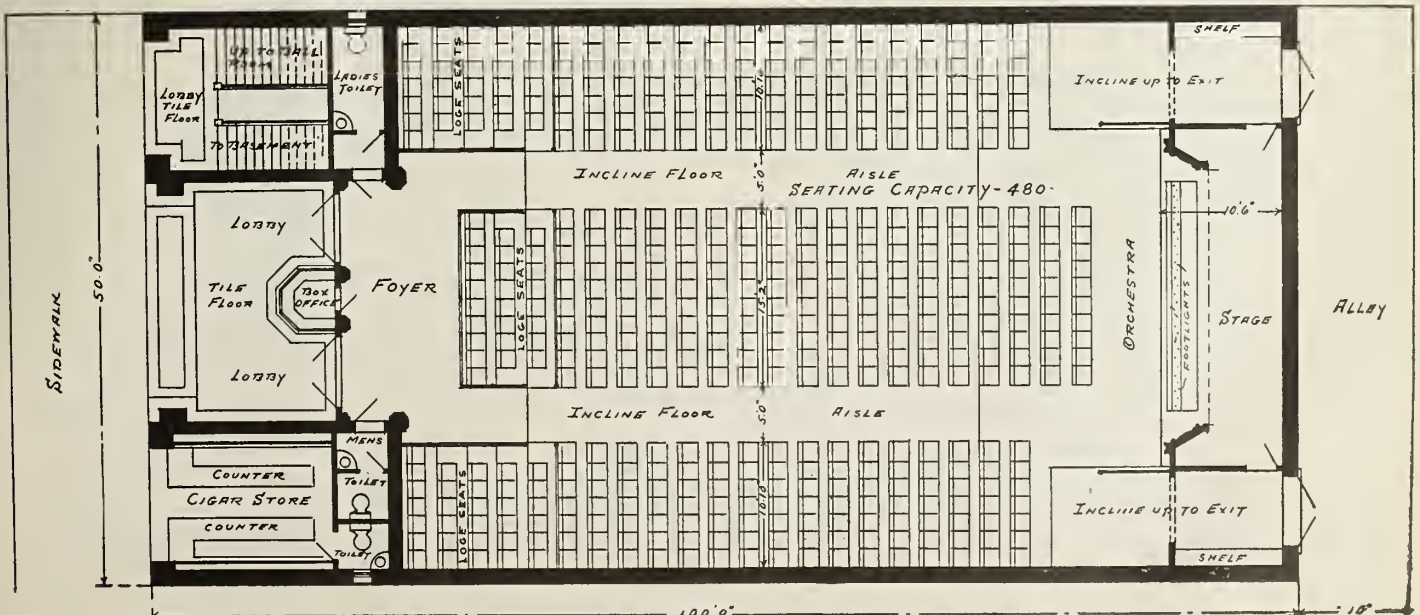

GROUND FLOOR PLAN OF THE GLOBE THEATRE, SAN PEDRO, CAL. (L. B. & A. L. Valk, Los Angeles, Cal., Architects)

Projection

CONDUCTED BY HERBERT W. ANDEM

Problems That Puzzle Projection People

Barney Cook, Fulton, N. Y.—Please give me your advice on the meniscus bi-convex condenser and kindly tell me what size to order. I am using a $6\frac{1}{2}$ and $7\frac{1}{2}$ now. I have a Fort Wayne A. C. to D. C. machine using 40 amperes at the arc, with a 100-foot throw and a 16 x 21 picture. I am using two plain condensers now. Two Power's 6A machines. I read your articles in the *News* every week. It certainly helps me out.

ANSWER.—It is not stated in your letter the difficulty you want to overcome in changing the system of the condensing lenses. It is therefore doubtful that a satisfactory reply can be given. The use of two plano-convex lenses mounted with their curved surfaces facing each other meets the requirements, all things considered, better than any other system.

However, assuming that you know the use of a meniscus and a bi-convex system of lenses will solve your difficulties with the plano-convex system, it can be recommended to use a 4-inch diameter meniscus lens of a short focus. If the focus is made too short it will necessitate the arc so close that the bottom carbon holder will touch the lens mounting.

Also, the lens will be thick at its center and so near to the intense heat of the arc, breakage will result from sudden heating or cooling. A 6-inch focus for the meniscus lens will perhaps be as near correct as it can be advised from the lack of more definite data from you.

The bi-convex lens to be of the standard $4\frac{1}{2}$ -inch diameter and this to have a focus of 7 inches and one surface curved more than the other. The greater curved side being toward the projection machine. This is the Sir John Herschel design of condensing lenses. These lenses can be obtained from the Bausch & Lomb Optical Company, Rochester, N. Y.

J. L. A., Bayonne, N. J.—I have an adjustable resistance and want to know the amperes I am burning. I cannot get the use of an ammeter. Can you tell me any way that the amperes can be found out? The power is from outside service and is 110 volts d. c.

Number of Amperes Burnt

ANSWER.—If you are sure the mains have exactly 110 volts at the point you are connected on, and the resistor has the resistance stamped on the name plate it may be approximated by calculations. It is, however, doubtful if you could come as near to the correct strength of current as to determine it by a simple trial of different capacity of fuses.

You might try it in this manner to gain some idea of the amperes being used. The plug fuses can be had in capacities of 15, 20, 25, and 30 amperes. If you insert in either receptacle of the cutout, say one 15-ampere fuse plug, and it holds for fifteen or twenty minutes, it is safe to say you are using below fifteen amperes.

If, however, this plug opens after about two or three minutes, the current strength is very close to the fifteen amperes. If the plug blows immediately upon closing the two carbons and striking an arc and the mica is considerably darkened, the current is very much above the fifteen amperes, and a twenty-five-ampere plug had best be tried as before. These are mere approximations and based upon the fuses being accurately rated. The only true way of telling the exact amperes is by the use of an ammeter.

HENRY THOMPSON, CINCINNATI, O.—(a) In winding film, should the emulsion side be uppermost? (b) In making patches should the emulsion be scraped from the piece nearest beginning of reel or at the tail end? (c) Which part of the patch should be cut—the part from which emulsion has been scraped or the other part? (d) What is the best method or preparation used in cleaning film?

ANSWER: (a) Whether the emulsion side of a film should be uppermost or not, will depend on the direction the film is being rewound on the reel. Bearing in mind that the emulsion side of a film has to be toward the arc lamp when projecting (otherwise any lettering will appear on the screen reading backwards) and there is less strain on the film unwinding it from the top reel by feeding it to the mechanism from the side of the reel toward the arc lamp, the emulsion side should be uppermost when winding with the reel turning in a "clock-wise" direction.

If your rewinder is so geared, or belted, that the reel revolves in a counter clock-wise direction (the rim on the right-hand side is passing upwards) then the emulsion side of the film should be the undermost side, and you should have the film feed into the mechanism in the best approved manner, as stated above.

(b) Your third question is also involved in the answer to this second question. So the answer to both questions will be stated together. The best practice to follow in joining films is to have the joint, or, more exactly, the lap, appear at the bottom of a picture. The eye is less apt to detect any carelessness from scraping too much off the emulsion side at the top of the next succeeding picture.

Where and How to Patch the Film

By making the film lap over the bottom, or foreground, of a picture, brings the line where the scraping off the emulsion ends at the top of the next picture. The film at this place in a picture is generally clear enough to reproduce the sky or the white ceiling of an interior view. Hence, too much scraping of the emulsion is not noticed as it would be in the foreground where the film is more or less heavily coated. So the direct answer is to scrape the emulsion from the end toward the reel while the film is being rewound on for projection.

At this end of the film should be cut to give the length to form the lap, generally about the distance of one perforation in the edges of the film. Now, the third question may be answered by saying, if the above method of joining films is followed then the part from which the emulsion has been scraped should be cut as indicated in the question, or the corners rounded off.

All operators do not prefer to round off these corners, but leave the film straight across the full width of the film. It will make a firmer joint and also is less liable to catch in the machine if the corners are cut; but not too much. It is also good practice to thin the edges across the film on both ends. By so doing the joint is a smoother running one and is more flexible.

The celluloid side of the end from which no scraping off of the emulsion is made should also be scraped clean to allow the cement to act freely with the new surface formed on the celluloid. (d) The cleansing of films had best be left to the film exchanges. There is on the market apparatus for this work and operators need only to clean off any oil splashes getting on the film and marring the projection.

Use Alcohol to Remove the Oil

This oil may be removed by a little alcohol sparingly applied on a piece of absorbent cotton. It is necessary to clean only a short length at a time and allow this to dry before winding; otherwise the film will stick and give more trouble than the oil.

Another way the oil can be removed is to apply a little precipitated chalk or the dry powder made by scraping a chalk crayon. This will absorb the oil quickly. Operators had best not attempt to do much cleansing of films beyond this emergency oil cleansing. A Mortimer film cleanser (Freeport, Me.) has proven successful in these emergencies.

ELIJAH GREATHOUSE, WEST SALEM, ILL.—We are using a Power's 6-A moving picture machine. Also using a direct current. At what angle should carbons stand to get the best results? Upper and lower.

Simplex
TRADE MARK

Simplex Projectors Used Exclusively

BEEN IN OPERATION EIGHT MONTHS
—ELEVEN HOURS DAILY

PRECISION PROJECTION—
NO DISAPPOINTMENTS

The Strand Theatre
of New York

Mark Strand & Co.
Theatre Company
Owners and Operators

OFFICE OF THE
MANAGING DIRECTOR

Mr. J. E. Robin,
Precision Machine Co.,
317 East 34th St.,
New York City.

My Dear Mr. Robin:

It has come to my notice through several different sources that certain parties are spreading a rumor about that I am about to take out the SIMPLEX machines now used in this theatre, and which have been used since we first opened, and to replace them with another make.

I wish to inform you that there is absolutely no truth in this statement, and can say that, after nine months of the hardest kind of usage, where the work expected of these machines has been most exacting, we have nothing but praise to offer, and the machines have proved that my judgment in selecting them after competitive trial was correct. They are giving the utmost satisfaction at the present time, and, as yet, there is no machine that has been submitted to the management that could take its place in this theatre during my direction here.

Wishing you every success that you deserve, I am
SLR/BS

Very sincerely yours,
S. L. Rothappel
Managing Director.

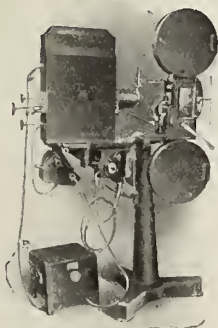

NO ONE IN THE BUSINESS IS AS EXACTING AND REQUIRES SO MUCH OF A PROJECTOR AS S. L. ROTHAPFEL, MANAGING DIRECTOR OF WORLD'S LARGEST AND MOST EXCLUSIVE PHOTOPLAY PALACE—COST ONE MILLION DOLLARS—SEATING CAPACITY 3500—EACH PERFORMANCE TWO HOURS OF PHOTOPLAY MASTERPIECES AND MUSIC.

When the other fellow endeavors to discredit the Simplex—examine the design, materials, workmanship, simplicity, accessibility and projection of his machine, and do not fail to consider the cost of upkeep.

BE SURE YOU ARE RIGHT BEFORE INVESTING YOUR MONEY.
In the meantime, write for Catalogue B.

MADE AND GUARANTEED BY
THE PRECISION MACHINE CO. INC.
317 East 34th St. New York

, Pa.

Increase Picture Quality Increase Your Profits

Picture patrons are critical of the films you show them. They know good quality, and they go where it is found. Along with good film service, you must have efficient lens equipment to hold your steady patrons. One sure way is to use

Bausch ^{and} Lomb Projection Lenses

The finest detail in every picture thrown on the screen, together with illumination of the utmost brilliancy, are assured when Bausch & Lomb objectives are used.

Regularly supplied with Edison and Nicholas Power Machines.

Send for our interesting free
booklet for owners and operators.

Bausch & Lomb Optical Co.
689 ST. PAUL STREET ROCHESTER, N. Y.

A clear picture
is as essential as a good
scenario. Because the
basic product is right
the clearest pictures are
on Eastman Film. Identifiable by the stencil
mark in the margin.

EASTMAN KODAK CO.,
ROCHESTER, N. Y.

pa...
(d) Wha
film?

PROJECTION

ANSWER: It would have been of much assistance to know what current strength you are using for your pictures to state exactly the best "set" for the carbons. As a matter of fact, it all depends upon the local conditions and the opinion of the operator as to what is the best set for the carbons. If this was an invariable condition would it not seem plausible that the manufacturers would make the carbon holders fixed at this particular angle.

As it is not a certain condition of things the holders are made to allow adjustments in all directions. The manufacturer states in his catalog that this style of lamp "is provided with every possible adjustment. The carbons can be placed at any angle desired." The general practice seems to be for direct current of small current strength to set the upper (positive) carbon if both are of the same diameter a little toward the back of the lower carbon.

This is in view of the fact to make the crater on the point of the top carbon burn toward the side facing the lenses. In this manner the most economy is obtained from the light and of the best quality also. There have been lamps made where the top carbon is at a right angle to the lower. These have practically been abandoned by the best manufacturers and the lamps are now manufactured so as to give about 70 degrees to both carbons.

If you do not use above 30 amperes we should say to place the top carbon back to about one-half of its diameter when both carbons are the same size. If you use $\frac{5}{8}$ -inch top and $\frac{1}{2}$ -inch lower then set to make a straight line with the sides of both carbons toward the lenses, the top carbon to be of the cored type and bottom solid.

If you find that the top carbon burns with a lip on the back towards the adjustment handles, then set the top not so much out of alignment to the lower carbon, remembering that with a greater current strength you must use larger diameter carbons and can also burn the arc with greater separation. Both of these conditions will alter the setting of the top carbon.

The Projection Machine Throws Light on the Failure of Some Exhibitors

WHY more attention is not given to the projection machine when an exhibitor is going into the "business" and is building a motion picture theatre is on the lips of every manufacturer. How many cases when the projection machine is left until the last thing, they themselves know.

A case can be cited where the roof, or ceiling, of the operating room had to be raised to permit the projection machines being placed within it. It is a just kick to complain of this lack of attention to construct the operating room of ample size and conveniently located for the best results in GOOD PROJECTION.

There is very little written on the methods of obtaining GOOD PROJECTION. Three books can be found concerning this branch of optical science, namely, Optical Projection—Lewis Wright; Book of the Lantern—T. C. Hepworth, and Art of Projection—Prof. A. E. Dolbear.

These three books devote about nine-tenths of their pages to projection of phenomena in physical science. This is of no use for motion picture work in assisting architects in designing theatre buildings for giving the operating room a proper construction and location. Richardson's Handbook for Operators and Managers, or, Hallberg's Electrical Talks and Questions for Operators, concern themselves more on the subjects of machine operation than to the best locations, or construction, of operating rooms.

Why Reliable Data Is Lacking

This lack of reliable data is explained by the fact that architects do not know the needs of the business in this respect. An instance can here be recited, quoting from "The Moving Picture Theatre," published by Guide Publishing Company, Cleveland, Ohio, the article by Ralph M. Hulett, architect. He points out all the essentials to a well-arranged house, but *entirely* omits to mention the operating room.

Further on, in this same book, is another article, "Projector Equipment," by Elwyn E. Oliver. The opening paragraph says, "One of the most important things to be considered in a motion picture project is the proper selection and placing of the projection equipment. We have often said to the prospective builder, plan your operating room, place in it the best of equipment and then build around it."

COMPENSARC

That's the device that saves Moving Picture men two-thirds on their electric light bills, and yet gives better light. Did you see our ad last week? Well, don't look it up. Just write for our

Booklet 5027

FORT WAYNE ELECTRIC WORKS
OF GENERAL ELECTRIC CO.
1704 BROADWAY
FORT WAYNE, INDIANA 733

"Nothing is so ridiculous as an elaborate front, beautiful interior decorations and a poorly projected picture. *Your patrons will excuse some faults in your decorations, or construction, if they are shown the best of projection.* It is the height of folly to lure them into your theatre by an attractive entrance and then disappoint them in what they want to see." . . . "The first thing for consideration is the machine operating room. Do not limit its size. Make it as roomy as possible, give plenty of ventilation from the ceiling. Place it as near the center of the auditorium and as near on a level with the screen as possible. We have seen many a large theatre in which projection has been *ruined* by placing the operating room in the wrong location."

It is to be regretted, years ago when the picture machine appeared, the only convenient place to put them was way up at the top in the second balcony. If they were put anywhere else, some seats would have to be sacrificed. Of course a manager thinks always of his box-office receipts. As long as it was possible to give a projection at long range and with any kind of convenience to be found at hand, he sat down on locating the outfit except at this place. Operators have met these conditions as a matter of fact, and long usage of placing the machine equipments in this part of a theatre is *now* hard to shake off.

Good Projection Is Demanded Today

The day has arrived where GOOD PROJECTION is demanded. It would take only a short time for the architects to design an artistic appearing room located at the front of the first balcony. These could be of the suspension type, so arrange with the general design of the balcony, as to not take up much space, and also, not to obstruct the clear view from the rear seats on the first floor, or, the seats in the balcony.

The style of entrance to balcony seats, now seen in modern theatres, is suggestive of what might be done with the operating room at this new location for it.

At this location the needs for good projection would be met in many points of vantage. It would be centrally located both in respect to height and distance to side walls. Also the distance to the screen is considerably shorter, aiding materially in better projection with less intensity of light at the arc.

The projector would not have to almost stand on its head while performing, as it now has to do, in its lofty location back in the second balcony.

It is high time architects, exhibitors and house managers give the projection machine its due share of attention when building a house.

Radium Gold Fibre Screen Now Adapted to Outdoor Advertising

A SERIES of experiments carried on for more than two years by the Alco Film Corporation and one of the companies which was absorbed by Alco has just come to a successful conclusion. The radium gold fibre screen is now made in all sizes and styles absolutely waterproof. It is thus available for all outdoor uses, such as advertising.

Long ago experiments had progressed to such a point that Alco might have announced a waterproof screen but the makers of this standard product did not wish to issue such a statement until they had applied tests of weather to the finished product. Consequently after the screen factories had reported the making of a waterproof screen composition, many screens of various sizes and styles were placed in exposed positions in various cities that the tests might show the average effect of the weather the country over.

So successful were these outside tests, that Alco now makes its announcement. A large outdoor advertiser awaited the result of the tests before signing a contract with Alco for 500 screens for his use in motion picture advertising in many American cities.

Tighten Building Laws in Boston

MOTION picture men in Boston are aroused at what they consider the unnecessary attitude of the Building Department toward new theatres. Serried ranks of three-flat houses are permitted in the outlying districts while the theatres are being persecuted, the latest one being the Park theatre, which has just been rebuilt and improved at a cost of \$50,000. The Modern theatre, one of the new houses, also suffered recently from this one-sided stringency.

Be sure to mention "ACCESSORY NEWS" when writing to advertisers.

SAVE 35%

on your

CARBONS

Burn your stubs with a

CARBON

Economizer



Pat. applied for.

Fits any lamp, gives perfect contact and conductivity, screw does not come in contact with carbon and will not weld to body of economizer.

SIMPLE and PRACTICAL

OVER 1500 IN USE

"MECHANICALLY CORRECT"!!!

Guaranteed to give satisfaction

\$1.25 Sizes \$2.00
Each. 1/2" - 5/8" - 3/4" Set—any sizes.

Sent postpaid upon receipt of Draft, Money Order or Cash.

THE CARBON ECONOMIZER CO.

757 W. Onondaga St. Syracuse, N. Y.

Burn Up Your Stubs With Our



No. 2 CARBON ECONOMIZER

Saves your carbons. Saves your carbon holders. All working parts

"AWAY FROM THE HEAT"

Means long life and efficiency—Better contact means better light.

Ask your operator. Sizes 1/2", 5/8", 3/4"

PRICE \$1.00 EACH

Sent anywhere post paid on receipt of price.

Motion Picture Specialty & Repair Co.

326 3rd Ave. Pittsburg, Pa.

BE UP TO DATE

INSTALL CORCORAN TANKS

Get No. 6 Price List

A. J. CORCORAN, Inc.

9 1/2 John Street New York

LANG'S FILM REELS

THE BEST MADE

14 in. \$1.50 12 in. \$1.25 10 in. \$1.00

CATALOGUE

LANG MFG. WORKS, Olean, N. Y.

HARRY K. LUCAS

"The Supply King"

ATLANTA, GEORGIA

Everything for the theatre, even the film. Catalogue for the asking. Write today.

Manufacturer of the

FAMOUS HAKILU PRODUCTS

Oil, cement, silver finish, gear compound, etc.

Wholesale and Retail.

DEALERS: Ask for Samples.

SLIDES

OF ALL DESCRIPTIONS

Excelsior Illustrating Co.
219 6th Avenue, New York City
Tel. 7760-7761 Chelsea

PLAYER SLIDES

Most Beautiful \$1.75 per dozen

NIAGARA SLIDE CO., Lockport, N. Y.

Your negative developed, printed and tilted complete
5c delivered within **12** hours
per foot

Titles **6c** per foot

GUNBY BROS., Inc.
145 West 45th Street New York City

SONG SLIDES

AND

WAR SLIDES

Write for Special Offer

NOVELTY - 67 W. 23d St., New York

Building and Furnishings

Increasing a Theatre's Usefulness

(Continued from page 105.)

Of course, this style of theatre building is not possible in all localities—not even in residential districts. It will not take the place of neighborhood theatres. It can only thrive in small communities—and no town will support more than one.

A glance at the illustrations will give anyone contemplating the erection of a similar theatre an adequate idea of the new style of community theatre. The front is particularly attractive either by day or night.

Brightest Spot in Town

By the use of numerous incandescent lights brilliantly lighting up the front the theatre becomes the brightest spot in the town after dark. The Globe is substantially built of brick, with concrete foundations. The brick is faced with cement plaster. The side on the street is ornamented with a staff composition worked in an artistic and pleasing manner.

A handsome tile floor has been laid in the lobby, and the sides of the entrance are decorated with a marble wainscoting, which extends all around, including the box office. Heavy plate glass in the entrance doors helps to give the front an appearance of elegance.

In addition to the means of income other than the theatre proper, there is a cigar store on the right which is constantly patronized not only by the audience before and after the showing of the pictures, but by the men in attendance at the lodge meetings and entertainments held other nights.

The bowling alley and billiard parlor have proved a profitable source of income.

The foyer has a staff paneled ceiling and the arch over the opening is resplendent with electric lights. Octagon pilasters add a massive, substantial appearance to the inside of the entrance.

The illumination not only outlines the whole front with



THE GLOBE THEATRE NO. 5, SAN PEDRO, CALIFORNIA, WITH A NIGHT VIEW OF THE SAME THEATRE.

great clearness, but the light shows with considerable distinctness a galvanized iron dome with pedestals on either side at the top of the building. A huge electric sign is embedded in the brick work flush with the plastering. The upper cornice is of galvanized iron as well as the dome and the pedestals.

Handsome Interior

The interior view of the theatre reveals careful designing with an idea of making use of all available space in accordance with the requirements of the modern picture theatre.

Nothing has been overlooked. Beauty of decoration, convenience and safety of patrons have received the strictest attention of the architects. Hand painted emblems are a feature of the walls in blue, and the ceiling is ornamented with an attractive stencil work border. The staff work is touched up with high-lighting gold leaf, which appears also on the ceiling beams, proscenium arch and in the ball room on the floor above.

The building covers a plot fifty by one hundred feet, and without the opera chairs, carpets, draperies, curtains, stage scenery and apparatus in the operator's booth, cost \$30,000. The property is valued at a similar sum. The total investment



INTERIOR OF BALLROOM, SAN PEDRO THEATRE BUILDING

of \$60,000 nets the owner, Luke Kelly, somewhat over ten per cent as rent. The basement brings in an income of \$95, the theatre \$325 and the ball room \$125 a month.

The ventilating system comprises two 24-inch intake and two 24-inch exhaust electric fans, which supply the right amount of fresh air, exhausting the foul air at all times. Gas radiators are used for heating. The indirect system of lighting is in use in both the theatre and the ball room.

In the theatre there are six staff bowls, which contain three 100-watt tungsten lamps with X-ray reflectors on three circuits. This makes possible the use of either one, two or all three lights at will. All the lights, ceiling as well as border, are in control from either the lobby or the operating booth.

Powers Machines in Booth

Two Powers 6-A projection machines have been installed, and the length of throw measures seventy feet. There are one dissolving stereopticon, one spot light and a mercury arc rectifier.

The seating capacity is 460, and the seats were furnished by the C. F. Weber Company.

The ball room illustration shows the interior on the second story, looking away from the entrance. It also shows the arrangement of the seats around the room and the paneled ceiling, the decorative effects, the system of indirect lighting, the ventilating openings in the ceiling, and the music stand, in the left hand corner.

In the theatre interior one may get an excellent idea of the ground floor arrangement. Here is a better view of the ceiling ventilating and indirect lighting systems. Two large ventilators are on either side of the proscenium arch, each directly over two exits.

New Harrisburg Theatre Added to Chain of Twenty

DECLARING it to be one in a chain of twenty motion picture theatres that Heimbinder & Gold, of New York City, are planning to get control of in cities between New York and Chicago, Jack Gold, one of the partners, has just announced that his firm has obtained a ten-year lease of the Handshaw theatre, at Third and Harris streets, this city. This theatre is one of the newest and best appointed in Harrisburg, and had been in operation only since last September by Charles Handshaw, the builder and owner. It has eleven exits, wide aisles, a seating capacity of 1,200, and is regarded as a model of construction for modern motion picture houses.

Mr. Gold, whose firm has begun operating the house under the name of the Family theatre and in accordance with progressive principles, told the representative of MOTION PICTURE NEWS that Heimbinder & Gold plan within the next few months to obtain control of a score of theatres in various cities, most of which they are now negotiating for. One of these is another new house just completed in another section of Harrisburg.

"The firm is composed of Morris Heimbinder and myself," said Mr. Gold today, "and we are independent of any other interests. Our home office is at 1122 Coney Island avenue, Brooklyn, and we already control a number of theatres in Greater New York, one in Jersey City and another in Newark, N. J. We are now negotiating for two houses in Philadelphia, one more in Harrisburg, one in Huntingdon, Pa., two in Pittsburgh, and plan ultimately to get several in Chicago."

Success of a National Cash Register

THE first man in Washington, D. C., to use the cash register designed for the motion picture house is Nat. Glasser, manager of the Leader. It is a very neat arrangement and greatly simplifies the strain of the ticket girls.

"I find this device a great time saver, in rush of business," said Mr. Glasser. "Besides, it permits the stand of the cash box to be known at any time. It is easily manipulated by young ladies, too. The fact that the tickets are stamped with the date of issue prevents some stray ticket from being used on any other day. I am thoroughly pleased with this up-to-date investment."

As a novelty, this register proved a drawing card for the Leader, as many of the passing public went into the show just to see how the device worked. Many questions were asked, which Manager Glasser was pleased to answer.

"Even mechanical appliances will bring a man to the movies," commented Mr. Glasser dryly. It is understood that other picture houses have arranged for the installation of these registers.

C. Howard Crane Architect of Liberty Theatre

THROUGH a regrettable typographical error in a recent issue of MOTION PICTURE NEWS, proper credit was not given to the architect of the Liberty theatre, Detroit. The name of C. Howard Crane, with offices in the Dime Savings Bank Building, that city, should have appeared in connection with the article. Only the first part of his name was used, thus making it seem as if a different person was responsible for the work done on the Liberty.

Inasmuch as Mr. Crane is an architect of considerable reputation and the architectural ideas embodied in this particular theatre were developed with a sureness of touch and striking technique, which come only from long experience, the editors of MOTION PICTURE NEWS feel that Mr. Crane's abilities cannot have too widespread publicity.

Novelty Slide Puts Out Feature Line

ADVERTISING pictures which are to appear on future dates has become one of the principal methods of advertising to regular patrons.

In order to help the exhibitor in doing this, the Novelty Slide Company is now putting out special slides for the four and five reel features, as well as regular two-reelers of General, Mutual and Universal programs. On special order slides may also be obtained of any other pictures desired outside of these releases.

MENGER & RING

302
W. 42nd
Street
New York

TELEPHONE
BRYANT 6621



FURNITURE & FURNISHINGS

On RENTAL
We equip your settings complete in accordance with your scenario.

WILLIAM BIRNS

103-105 West 37th St.
Phone: Greeley 6255.

ROLL TICKETS

Specially Printed and Absolutely Guaranteed
Cash with order. No C.O.D. at these prices.
50,000 for \$5.40 200,000 for \$15.30
30,000 for 4.50 100,000 for 9.00
Write for Samples and Prices on Other Quantities.

Rees Ticket Co., 400 So. 10th St., Omaha, Neb.

Make Your Lobby Display Attractive

There is nothing more fascinating to the public than a bright brass frame to display your photos or posters.

We make Lobby and Theatre Fixtures and Brass Rails of every description.

Don't fail to visit our Showrooms.
Write for catalog.

THE NEWMAN MFG. CO.
717 Sycamore St., Cincinnati, Ohio
Branch Factories and Show Rooms:
101 Fourth Ave., New York, N. Y.
106-108 W. Lake St., Chicago, Ill.
Established 1882.

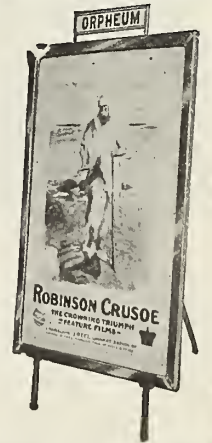

We Can Equip Your Theatre Complete

We are Distributors for the Powers, Edison, Motiograph and Simplex Machines, and Genuine parts, also Poster Frames, Indirect and Semi-Indirect Lighting Fixtures, Tickets, Screens, etc.

We sell for cash or on the easy payment plan.

Write today for our new catalog just off the press.

AMUSEMENT SUPPLY CO.

160 No. Fifth Avenue

Chicago, Illinois

Directory of New Theatres

Test Case Over Boston Building Law

NOT only motion picture interests but practically the entire city of Boston is watching a fight which one motion picture house manager there is waging against City Hall, the outcome of which will be decided by the courts.

This manager is Joseph L. Roth, of the new Park theatre, which opened Monday evening, December 7, after months spent in renovating and refurnishing it at a cost of upwards of \$50,000. It was formerly one of the oldest homes of the spoken drama in Boston and when the new owners acquired it they went to work with vim to make it one of the most modern and beautiful theatres in the country.

The theatre was ready for the opening ceremony several days before it actually took place, the delay being occasioned by the interference of Building Commissioner Patrick O'Hearn, whose



STAGE AND ORCHESTRA, NEW PARK THEATRE, BOSTON, MASS.

interpretation of the law governing fire escapes disagreed with conditions he found at the theatre upon inspection, although he had approved the plans for the remodelled building when they were submitted to him early in the summer.

By almost superhuman efforts the changes ordered by O'Hearn were completed two hours before the opening time on Monday evening. Then Manager Roth hastened to Mayor Curley's office to get his license, but License Clerk Casey declared that the Mayor had decided not to issue a license to show motion pictures on the ground that as altered the theatre did not conform to the new building laws, which require that motion pictures be shown only in buildings of first class construction.

Manager Roth argued that the plans for remodelling the theatre were filed months before the new law went into effect in October, but the Mayor, supported by O'Hearn's recommendation, was obdurate. The management contended that motion pictures were shown in the theatre two years ago, but Commissioner O'Hearn replied that the law was not then in effect. Roth appealed to Corporation Counsel Sullivan and the latter gave it as his opinion that the usual theatrical license which the Park theatre had obtained was sufficient to allow the exhibition of motion pictures. Even this failed to move the Mayor.

Because of the extensive arrangements which the management had made for the opening performance, however, Mayor Curley gave special permission to Manager Roth to open the theatre for one performance, allowing motion pictures to be shown as announced. The Mayor gave warning that Commissioner O'Hearn would close the house the next day at the first attempt to exhibit

a film and that it would remain closed until the courts found that O'Hearn was wrong or that the management would have to spend thousands of dollars more in making the theatre a first class building.

The theatre did open the next morning, the motion picture show was put on, and it ran all of the following week. There has been no official interference since at the house, but Mayor Curley has filed a bill in equity in the Superior Court asking that the Park theatre be closed or restrained from showing motion pictures in alleged violation of the law.

The suit is considered a friendly one, with the Park being selected as a test case to try out the strength of the new law.

Bellevue Theatre Opens in Philadelphia

THE Bellevue theatre opened to the public on December 10, is situated on Front street near Susquehanna, Philadelphia, in the district known as Kensington, the home of varied industries and a large, live population.

The house, erected at a cost of \$125,000, is owned by the St. Charles Amusement Company, and is under the management of Milton Rogasner.

Built of concrete with an imposing facade and a ticket booth of marble and mahogany, the entrance is decidedly attractive.

There is a large lobby twenty by seventy-six, with stone tiled floor. The walls lined with different sized posters in specially constructed frames heralding the week's productions.

A brass railing divides the lobby so that the entries and exits can be kept separate to avoid crowding and confusion. There are one thousand seats, standing room for one hundred, with forty-eight exits and thirty windows.

The place is carpeted throughout with rich crimson velvet carpet; the walls decorated by the Venetian Decorating Company, are in artistic terra cotta tones with lighter borders.

The building is heated by steam and the latest ventilating system has been installed by which the air is changed every five minutes.

The lighting fixtures, furnished by the Horn and Brannen Company, of Philadelphia, are of solid brass with opal globes; the indirect system of lighting is used and the effect is soft and pleasing. Twenty-inch wooden chairs with wide aisles and plenty of space between seats promise comfort and safety to patrons.

A Radium Gold Fibre screen assures good pictures with the aid of the latest projection machine.

A Haskell organ with the electric echo will add to the appeal of the theatre, to say nothing of the five-piece orchestra which will be used in conjunction with the organ.

The performance will be continuous, running daily from 1 to 11 p. m. Admission will be five and ten cents and only good feature photo plays will be used, obtained through the Stanley Booking Company. Every form of advertising is being used to give the new house a first boost. A wagon parading the streets, circulars distributed generously, large bill board signs, and notices in all the daily papers gave no one a chance to forget the opening date.

On this occasion palms and potted plants together with many cut flowers gave the theatre a gala appearance.

The opening attraction was "The Tangle," a Broadway star feature. Thousands of eager patrons crowded the doors from 8 until 11. For the rest of this week Geo. Kline's "Vendetta" and "The Painted World" will make up the program.

This new and up-to-date playhouse promises to be a big winner for its owners.

Building Boom in Wisconsin

WITH the advent of winter, Wisconsin and Northern Michigan are experiencing a building boom in motion picture houses such as has seldom been witnessed. There are at this writing no less than thirteen theatres either now under construction or for

Directory of New Theatres

which plans are being drawn. This in the face of the fact that the traveling theatrical attractions have almost deserted this territory on account of bad business. State exhibitors everywhere report business most encouraging and they all are looking for a wonderful successful winter despite adverse conditions.

Most prominent among those houses building is that which Leslie J. Dietz, son of the famous defender of Cameron Dam, is building at Chippewa Falls. It is to be known as the Metropolitan, is 28 x 110 feet, will seat 325 and cost close to \$3,000. On account of the prominence of its builder, who helped his father in the defense of Cameron Dam, the house has already received very extensive publicity through the state. The new house is to be managed by Eli Nelson.

Port Washington, Wisconsin is to have a new house. It is being erected by Ziller and Siebert, who announce that it will be ready to open about Christmas. The theatre, which is to be named by a popular voting contest will seat 450 when completed.

South Milwaukee is also to have a new theatre. The Lion will be its name and it is expected to be opened by December 7. C. Brum has announced that his Princess theatre at North Milwaukee will be opened some time next week. Four reels are to be shown at 10 cents, Universal service being used.

On December 5 the Moore Brothers of Mauston opened their new Gem Theatre in that city. The house seats 300 people and is modern in every respect. Three reels are shown and an admission price of 5 and 10 cents charged. A four piece orchestra furnishes the music. Universal service is used.

The Delft Theatres, Inc., under the management of H. S. Callup, will have a string of three theatres, all new houses by January 2. Two of their new houses the Delft at Marquette and Escanaba, Michigan, are already opened, the first having been opened November 4, while the last named was opened November 16. Mr. Callup reports that the Delft Theatre at Munising which is now in the process of construction is progressing very rapidly and will be ready for occupation by the first of the year. All three theatres are of the latest and most modern construction and will play high class attractions and feature photoplays. They are all booked by the General Film Co. The Delft in Marquette cost \$20,000 to erect and seats 400 people, the house at Escanaba seats 900 and cost \$60,000, while the house at Munising when completed will cost \$25,000 and seat 500.

In addition to the above the following theatres which have already been reported in "The News" are at present under construction. A \$15,000 theatre at Shawano 45 x 110 which is being constructed by George Nagle, a \$30,000 house at Green Bay now under construction for Henry Goldman; a 1,500 seat house for P. J. Hansen and Son, Antigo, for which the property has been purchased and plans are now being drawn. The house is to be 44 x 185 and will contain a main floor and two balconies. A \$15,000 house which is being built at Algona for David Burke. The house is to be 45 x 60 and will seat 400.

\$60,000 Theatre Opens in Nebraska

Swan & Swartz opened their new \$60,000 motion picture theatre, The Chrystal, at Kearney, Neb., recently, to capacity houses. The theatre seats 1,100 people. Each chair cost \$1.50 and the finishing and fixtures cost accordingly.

The theatre is one of the works of ornamental art in Nebraska motion picturedom, as being one of the coziest, best arranged and most comfortable in the state. Opening day saw capacity houses, and indications are that Swan & Swartz, successes in their field, will make a big success out of this venture. They are foremost among the state's agitators for especially built theatres for motion pictures.

David Delphus is proprietor of a new house opening this week at Bridgeville, Pa. The house is a cozy one and has a seating capacity of 265. It opened with the feature Washington at Valley Forge.

Long Beach, Miss., has had its first successful moving picture show this summer and fall under the management of the Naia Amusement Company. The manager is Charles Thornton and William Boyer is the operator. This popular summer resort furnished excellent patronage for the Naia.

Along the Mississippi Valley

Fayard's Pictorium, Pass Christian, Miss., one of the oldest moving picture shows along the Mississippi gulf coast, was recently destroyed in a fire which swept part of the city. The management did not allow a little thing like a fire to put them out of business, but promptly relocated in another building. Considerable improvements are said to be planned for next season.

The capital stock of the Jena Amusement Company, Jena, La., has been increased \$2,000 and a player piano installed. The company reports a considerable increase in business.

Under the new management of George C. Cacum, the Yazoo Theatre, Yazoo City, Miss., has taken on new life. Mr. Cacum has devoted his attention to seeing that the public is supplied with a splendid film program, supplemented by good music, which is furnished by an orchestra from Memphis under the direction of Prof. Monteabarro. Mr. Cacum is also a singer of note, having at one time been a member of the Savage Opera company. A unique feature of the opening performance under his management was a dance enjoyed by his patrons.

The new Hippodrome Theatre at Eighth and Monmouth streets, Newport, Ky., is now under roof and last week architects Zettl and Rapp left the following contracts: Electrical equipment, Queen City Electric Company; painting, Joseph Steggeman; roofing and sheet metal, Thomas Lee; plastering, Gus Sauer and Marble and tile finishing, T. H. Wilson and Son.

A. E. Elliott has purchased the Maze Theatre at 12th and Baltimore streets, Kansas City, and will change that to a straight 5-cent show. He will also use the Universal Program at this place and will add vaudeville musical comedies. This house is a part of the Sexton Hotel, seats over 600, the location being across the corner from the Baltimore and the new Muelbach hotel, also on the main traffic way to the new Orpheum Theatre, seems to make the prospects very glowing for complete success.

Among the North California Theatres

The New Theatre, located on Polk street, near the corner of Bush, San Francisco, is now being conducted under new management, having been taken over during the past week by H. S. Levin. The location is on a leading amusement street and on one of the leading thoroughfares leading to the Panama-Pacific International Exposition grounds. The new owner is no stranger in the local field, having for some time conducted the Elite Theatre in the Sacramento street district. This theatre was recently disposed of, following a mysterious explosion that did considerable damage.

The Hub Theatre, conducted at Mill Valley, Cal., by A. Pabst, will occupy a new home in that city early in the spring, probably about the first of March. A site for a new theatre building has been secured near the present structure and work on the foundation of this has already been commenced. The building will contain a theatre with a seating capacity of about seven hundred, with two stores in front, one on each side of the lobby.

It is being erected by C. L. Mehrten, a prominent exhibitor of Berkeley, Cal., who is also treasurer of the Motion Picture Exhibitors' League of California, and a veteran purveyor of amusement. A stage will be installed, enabling the presentation of various forms of entertainment, if desired, and improved systems of lighting, heating and ventilating will be installed. It is the intention of Mr. Pabst to close the present small house as soon as the new one is ready.

A splendid new moving picture theatre is being erected at Turlock, Cal., by Fresno interests and will be opened shortly by F. Stamm, a well known exhibitor of Antioch, Cal., who is interested in several theatres. The new house will be in charge of H. Krebs.

Music and the Picture

Editor's Note.—This department is prepared to answer all questions from exhibitors relating to the use of music in connection with photoplays, and to suggest suitable music for current pictures. Correspondence will be welcomed

How One Exhibitor Handles His Music

REX MIDGLEY, of the Franklin theatre, one of the latest additions to the long list of motion picture houses at Oakland, Cal., is an enthusiastic believer in the value of good music in conjunction with motion picture shows. Not only does he believe that good music is a prime necessity to the proper presentation of motion pictures, but he furnishes the music in his own house and makes a proper charge for it.

Mr. Midgley is best known through his remarkable success in the motion picture business at Salt Lake City. His largest house there, seating 3,000 persons, is regarded as being one of the finest in the entire country, and no small part of its reputation was built upon the excellence of the musical program. The twenty-six piece orchestra installed in this theatre was the finest in Salt Lake City, and almost as many came to hear the music as to see the pictures.

What was accomplished at Salt Lake City is being done at the new Oakland house, although on a rather smaller scale. The new theatre has a seating capacity of but 1,000, instead of 3,000, and the prices of admission are higher, but a longer program is rendered and the music is strongly featured.

The Franklin theatre was opened with a series of spectacular features, but a change in policy has been made of late, and Mr. Midgley is now offering what he terms a vaudeville-motion picture program, consisting of strong features, educational subjects, comedies and weeklies. He is now attempting to secure expressions of opinion in regard to the programs, and the general policy of the house, from his patrons and has been printing a series of questions for criticism in the programs which are distributed. Many answers have been received and some of the suggestions have been valuable ones. As a special inducement to secure answers, the offer was made recently of giving free tickets with the return of any four copies of the program with candid opinions on the questions.

Some of the questions have been very vital ones, for instance: In what particular is our performance overdone? Wherein does it show weakness? How can we, in your opinion, make our performances more attractive? What form of advertising that we use gives you the most information regarding coming attractions and the current program? In what newspapers do you read the dramatic and motion picture news? Do you get "value received" when you go to the Franklin?

One of the features of the musical program at the Franklin theatre is the pipe organ recital given by Edgar Bayliss, who has been with Mr. Midgley for the past three years. These recitals have proved to be a great drawing card, and the "Old Melodies" arranged by this performer are especially appreciated. The building up of an efficient orchestra has been found to be a matter of much hard work and considerable time. The results, however, are considered by Mr. Midgley to be well worth the effort, especially since the tendency of the motion picture business is toward high grade performances, both in pictures and in music.

Appreciates Wurlitzer Orchestra

THE Rudolph Wurlitzer Company has issued, among its attractive advertising matter, a cardboard folder containing and enthusiastic letter from the L. and B. Amusement Company, Inc., New York, proprietors of the Heights theatre. In speaking of the Wurlitzer Orchestra, style K, William A. Landau, the manager of the theatre, writes:

"Both from a musical standpoint and for its drawing power,

we must really compliment you very highly upon the production of this wonderful instrument, which we believe will become universally used in connection with motion picture exhibitors."

Users of the Wurlitzer number over a thousand from coast to coast, and the fine tone quality of the instrument adds to the pleasure of patrons desiring something in addition to their motion picture entertainment.

The Wurlitzer Orchestra can be obtained on attractive credit terms, a plan which makes it possible for the instrument to earn its own way for an exhibitor.

The company has numerous branches throughout the country, New York, Philadelphia, Albany, Buffalo, Rochester and Syracuse. The main office is located in Cincinnati.

Building Boom is on in Cleveland

WHILE a business depression may be felt in certain lines and in certain parts of the country a review of motion picture theatres proposed or under construction in Ohio reveals the fact that optimism holds sway in this particular field. The past few months have been particularly fruitful among Cleveland picture theatres.

The Liberty, owned by the Doan Square Realty Company, under construction at Superior avenue and E. 114th street, Cleveland, though not primarily a picture house, will run features on Sundays and from time to time during the week. It will be completed and opened formally by its promoters February 1.

The new theatre under construction for Jacob Babin, at Broadway and E. 79th street, will be completed and opened soon. Mr. Babin has leased it to an amusement company formed for the enterprise. Among theatres contemplated or under construction over the state are the following:

Other Theatres Planned Through Ohio

A \$10,000 one-story house at Market and Franklin streets, Troy, O., will be built for T. C. Shilling, Dayton, after plans drawn by G. A. Niehaus, architect. A theatre and store building will be constructed for J. C. Campbell, Hartman building, Columbus. The plans provide seating capacity for 900. J. L. Silsbee, architect, prepared plans for a \$6,000 theatre for H. E. Wurst, to be built on Broad street, Elyria.

H. W. Riddle will build a \$30,000 brick and tile theatre on Main street, Ravenna. The building planned for Paul Stanffer, Columbus, will not be started until spring. The T. R. Morris & Co. has the general contract for construction. William Standen, Wadsworth, O., will build an \$8,000 theatre. W. C. Morton, Schofield building, probably will remodel his building at Euclid avenue and E. 79th street, Cleveland, into a picture show. O. H. Sebring is building a theatre at Sebring, O., at a cost of \$12,000, following the plans of Youngstown architects. Contractors are at work on a three-story brick picture theatre for Ort Brothers, at Newcomertown.

Louis Chakaris, picture theatre proprietor at Springfield, O., has plans ahead for a building to cost \$150,000. Edward Miller, Cleveland, will build a theatre costing \$35,000 at Woodhill Road and Woodland avenue, following plans drawn by E. H. Goldfein, architect. The Bellaire Amusement Company, Rayland, O., will build a theatre costing \$12,000.

August Helmoldt has closed bids on a theatre to be built for him at Bucyrus at a cost of \$8,000. Cliff Sutton will erect a theatre at Xenia, after plans drawn by a Detroit architect.

ACCESSORY AID

We stand ready and willing at all times to help our readers in making purchases. We buy nothing for you, but merely advise as to where **first class goods** may be purchased. We know the market.

PROJECTION PROBLEMS ANSWERED

Troubles come up in every booth. Have them solved. The "NEWS" has a **projection expert second to none**, and he is at your service.

Without obligation on my part, please give me full advice on the following:

.....
.....
.....
.....
.....
.....
.....
.....

Name

Theatre

Address

MOVING PICTURE THEATRE MAILING LISTS FOR SALE

20,192, covering United States and Canada, Price \$40.00, or \$3.50 per thousand for such states as you want.

- 795 Film Exchanges, U. S.\$3.50
- 70 Manufacturers and Studios, U. S..... 1.00
- 34 Moving Picture Machine Mfrs. and Dealers..... 1.00
- 231 Film Exchanges, Foreign Countries..... 3.00
- 520 Moving Picture Theatres, Foreign Countries.... 3.00

Ask us for full particulars.

TRADE CIRCULAR ADDRESSING CO.

166 West Adams Street, Chicago
Established 1880

PERFECT DEVELOPING AND PRINTING

For Amateurs and Professionals in any Quantities,
WE GUARANTEE QUALITY PLUS PROMPT DELIVERY AND
PERSONAL SERVICE.

Prices, References and Factory Description Sent at Your Request

INDUSTRIAL MOVING PICTURE COMPANY
223-233 West Erie Street, Chicago

Our Factory Is Yours!

Negative assemblers, project-
ing machines and an equipment
second to none, with an organiza-
tion of experienced people al-
ways at your SERVICE for DE-
VELOPING and PRINTING.

EVANS FILM MFG. CO.
Incorporated

416-22 WEST 216th STREET
Tel. 6881-6882 Audubon at Broadway, New York

CLASSIFIED

FOR SALE

Five Powers' Machines, one 3-reel
feature, one 2-reel feature, for sale,
cheap. No reasonable offer refused.
Exhibitors, R. 403, 110 W. 40th St.,
New York.

There Are Several

interesting business boosting
schemes outlined in the "Live Wire
Exhibitors'" department of this
issue. It will pay you to read
every one of them.

Economizer Made of Brass and Copper Alloy

THE No. 2 Economizer, shown on this page, is the invention of Robert Webb, 326 Third avenue, Pittsburgh, Pa. Mr. Webb is one of the old school operators having been employed as operator and repairman for the Royer and Balsdon circuit of theatres, one of the first string of motion picture shows in the Pittsburgh district.



Mr. Webb is also a first-class machinist and has invented several useful devices used on motion picture apparatus, the latest of which is the No. 2 Economizer. The metal used in this is of high conductivity, brass and copper alloy. The two sides are machined to fit accurately, are held in place by a steel shaft and clamped by means of steel studs and thumb nut. By means of this construction the carbon is held in a vise like grip.

The carbon end is bored to fit the standard sizes of carbons 1/2, 5/8 and 3/4 inches, giving the carbon contact of about 80 per cent. of its circumference. All working parts are away from the heat of the arc, thereby insuring long life and preventing the parts from binding. As the carbon burns shorter, it can be raised up and clamped to 1/8 inch of carbon and will give perfect contact.

When the thumb nut is loosened the jaws part automatically and do not have to be pulled apart. Many operators use these economizers at all times, claiming to get better light and being able to change carbons much quicker. Mr. Webb is also the inventor of the Webb terminal, shown here; this terminal has been on the market now for eight years, and will be remembered as the first terminal designed especially for motion picture arc lamps. The construction of this terminal is very simple, made of copper alloy, extra heavy and is clamped by four screws.

The No. 1 or short terminal is intended to be used on the lower binding post, and the No. 2 or long terminal for the top. On account of the extra length the wire lead is kept away from the intense heat of the arc, and will stand an amperage of 100. Mr. Webb has also to his credit other devices, as carbon holders, the film guide aperture plate and the Webb rewinder for hand or motor drive.

Hyman Leases Atlanta Theatre

ARTHUR S. HYMAN has taken over from Jake Wells a two-year lease on the Grand Opera House, Atlanta, and has opened the theatre with the "Belgian Battlefields" picture taken by Edwin F. Wiegler, staff photographer of the Chicago "Tribune," and a second war film on "The Austro-Servian War."

The opening of the doors was a signal for a rush for seats, and Mr. Hyman is decidedly optimistic as to the future of the Grand.

This theatre, one of the largest in America, has had quite a fluctuating career as a motion picture house. Harry Hearn, resident manager for Mr. Wells, stated when the theatre was shut down a few weeks ago that the sole reason for its closing was the lack of good feature films, such as are in demand by Atlanta audiences. The houses were big enough, but the supply of films short.

The fact that the Grand is popular is further evidenced in the fact that only a few months ago this house set a record by drawing more than 40,000 paid admissions in twenty-four consecutive performances.

E. Combs, an expert from California, comes here to be manager of the Grand. Mr. Hyman, through his residence here, will be enabled to be constantly in personal supervision of his theatre.

Continuous performances will be given from 12:50 noon until 11 P. M. The admission price will be five cents in the afternoon and 10 cents evenings.

New Shipment of Carbons in Sight

C. A. DU BOSCH, sales manager for Hugo Reisinger, sole importer of "Electra" carbons, reports that shipments in limited quantities have been received and that others are now on the way.

This is a good sign, for it means that the foreign carbon situation is no longer critical. Relief is already at hand.

PROJECTION PROBLEMS ANSWERED

Troubles are continually coming up in every booth. Why not see whether the other fellow can help you? Our projection expert is ready and willing to answer any and all questions

WHICH YOU MAY ASK

Without obligation on my part please give me full advice on the following:

.....
 Name
 Theatre
 Address



From a dead one to a Live One---in one leap

IF we were to write you a hundred page book we couldn't possibly drive home with such sledge-hammer force the mighty argument and lesson shown here in this photograph. It's the story of a dead show house that came back to life **in one leap** and to such a degree of life that the owners could hardly believe their own eyes. To quote from one of the owners' letters, he says: "**The greatest thing that ever happened to this business.**" This particular house is situated in a fairly good section of a mediocre show town. The management attempted to win patronage by having their place very swell so they dolled this house up fine. Business didn't seem to come. Then they put out a swell steel canopy in front; that didn't help. They employed methods used by new houses as regards their interior, and thought that would help. They tried everything they knew with little or no results. **THEN** they asked the Morgan Lithograph Co. for suggestions and advice.

WE asked them to send us a photo of exactly the way their house looked. **THEN**—we advised them to plaster their front (beautiful and expensive as it was) with Morgan Posters—striking Morgan Posters. At first they let out an awful yell, then they considered our suggestion—**THEN** they followed out our suggestion. All over that expensive front they plastered posters—over the canopy—on the canopy—in the center of the doors, on the sides of the doors, in the lobby, everywhere and anywhere posters could be placed, and results?—presto—like magic their business increased, and has been on the increase ever since. At first they said, "Oh, no, we won't use posters. What? on our brand new beautiful costly canopy? Oh, no, nothing doing." Then on our advice they watched posters as shown in the picture above. **NOW** their house is doing a smashing business every night and **POSTERS DID IT**, and posters will do it for you. Likewise, do we wish to **HAMMER** it in to you to **USE POSTERS**, big, clean, bright, snappy posters, new every blessed day and **WATCH YOUR RESULTS**. Let us tell you a little more about this poster question. It is vital to your business. Write direct to The Morgan Lithograph Co., Cleveland, Ohio.



PATHÉ

THE BOMB BOY

An American Pathe comedy-drama in three parts featuring ERNEST TRUEX, the star of the New York success "The Dummy." A mixture of laughs and thrills that will make any exhibitor a favorite with his public. 1-3-6 sheet posters.

THE RED SCAR OF COURAGE

A two-part Pathe war drama of the better sort, combined with "A STORM ON THE WELSH COAST," a beautiful scenic. 1 sheet posters.

RASTUS' RABID RABBIT HUNT

An animated cartoon comedy by J. R. Bray, combined with "GINGI (SOUTHERN INDIA)," a scenic. Rastus is a scream. 1 sheet posters.

THE SECRET OF THE MOUNTAIN

A Pathe made four-part drama, combined with "SUGAR MAKING (CUBA)" an educational. A strong story of a youthful sowing of wild oats which brings poverty and suffering to innocent persons but makes a man of the offender in the end. 1-3-6 sheet posters.

THE PATHE NEWS

the oldest and best of all pictorial weeklies.

EXCHANGES IN ALL

THE PRINCIPAL CITIES

THE ECLECTIC

110 W. 40TH STREET



FILM COMPANY

NEW YORK

JANUARY 2, 1915

Motion Picture News

HAS THE QUALITY CIRCULATION OF THE TRADE

PARAMOUNT PICTURES

JESSE L. LASKY

PRESENTS

DUSTIN FARNUM

THE FOREMOST AMERICAN FAVORITE
PLAYING HIS ORIGINAL STELLAR ROLE
IN A PICTURIZATION OF THE
SOUTHERN ROMANTIC DRAMA

**CAMEO
KIRBY**

By BOOTH TARKINGTON & HARRY LEON WILSON
RELEASED DEC 24

By ARRANGEMENT WITH
THE LEBLER CO

JESSE L. LASKY FEATURE PLAY CO.

220 WEST 48TH STREET NEW YORK CITY

JESSE L. LASKY PRESIDENT SAMUEL GOLDFISH TREAS. & GENL. MANAGER CECIL B. DeMILLE DIRECTOR GENERAL

ROBERT LEONARD AND ELLA HALL
IN

DINING ROOM

THE MASTER KEY

by JOHN FLEMING WILSON

*A Thrilling Story of
Mystery and Romance!*

FIFTEEN MOVING WEEKS
UNIVERSAL
THIRTY PICTURES REELS

SPECIAL
UNIVERSAL
EPISODE (Continued)



HENRY W. SAVAGE
 (In association with the Famous Players Film Co.)
 Offers

EDWARD ABELES



\$\$\$ **THE MILLION** \$\$\$

A mystery farce with as many laughs as the title, in which the star impersonates six entirely distinct characters.

IN FOUR PARTS — RELEASED DEC. 31 ST.

Produced by the

FAMOUS PLAYERS FILM CO.

ADOLPH ZUKOR, President,
DANIEL FROHMAN, Managing Director **EDWIN S. PORTER**, Technical Director

Executive Offices,
213-229 W. 26TH STREET, NEW YORK.



SPECIAL ANNOUNCEMENT

Selig Program for the Year 1915

A HOST OF HIGH CLASS PICTURE PLAY PRODUCTIONS
IN PREPARATION TO MAINTAIN THE SELIG STANDARD

SELIG SPECTACULAR SPECIALS

Exhibitors can expect during the year 1915, in addition to the Selig Diamond Specials and the Regular Weekly Program, several gigantic, spectacular Specials, release dates for which will be announced later. Among these big releases for early in the new year will be the following:

"THE CARPET FROM BAGDAD" (5 reels). A spectacular Oriental adventure story, made from the popular novel, written by HAROLD MacGRATH, and featuring KATHLYN WILLIAMS, CHARLES CLARY, WHEELER OAKMAN, GUY OLIVER, EUGENIE BESSERER and others.

"THE ROSARY," a great multiple reel picture filmed from the intensely dramatic and soul-stirring drama written by EDWARD E. ROSE, made world-famous by the all-star theatrical company of ROWLAND & CLIFFORD; featuring KATHLYN WILLIAMS and her supporting company.

"THE SERVANT IN THE HOUSE," filmed from that unequalled and startling drama, written by CHARLES RANN KENNEDY, with modern Christianity as its theme, and in which TYRONE POWER, that leading dramatic star, who carried the original stage production to a pinnacle of exalted success, will be featured.

"THE NE'ER DO WELL," a story of adventure in Panama, from REX BEACH'S great romantic novel, in which KATHLYN WILLIAMS and her supporting company will be featured.

"A TEXAS STEER" (5 reels), an elaborate picture-play made from that hilariously popular and ever delightful CHARLES HOYT comedy, featuring TYRONE POWER, as "Maverick Brander."

"THE CRISIS," by WINSTON CHURCHILL—one of the famous books of a decade and which tells one of the most thrilling stories of Civil War adventure ever written, will be reproduced in motion pictures in an elaborate and spectacular manner. The release of "THE CRISIS" will inaugurate an epoch in picture-play making.

Others of Equal Interest Will Follow.

A HAPPY AND PROSPEROUS NEW YEAR TO ALL

THE SELIG POLYSCOPE COMPANY
EXECUTIVE OFFICES, CHICAGO, ILL., 20 E. RANDOLPH ST.

SPECIAL ANNOUNCEMENT**Selig Program for the Year 1915****SELIG DIAMOND SPECIALS**

Exhibitors who have found the three-reel SELIG DIAMOND SPECIALS profitable, will be gratified to learn that the ones to be released during the coming months will prove to be even better.

In the three big Selig Studios there are in work at the present time, a series of SELIG DIAMOND SPECIALS (approximately three reels each), which will be released at frequent intervals. These DIAMOND SPECIALS are being filmed along the same lines that have given distinction to Selig productions. The scenarios for these DIAMOND SPECIALS are based upon the most celebrated novels and stage productions which have become popular during the past few months. They will be released through the Special Feature Department of the General Film Company.

SELIG REGULAR WEEKLY PROGRAM

During the past year, the REGULAR SELIG WEEKLY PROGRAM has consisted of seven releases per week (including the Monday and Thursday release of the HEARST-SELIG NEWS PICTORIAL).

The SELIG REGULAR WEEKLY PROGRAM for the year 1915, will include multiple reel releases of such a high character and superior quality that actual competition will be practically eliminated.

There has been such a demand for the SELIG JUNGLE-ZOO WILD ANIMAL PICTURES that special efforts are to be made for the release of a greater number on the REGULAR WEEKLY PROGRAM.

HEARST-SELIG NEWS PICTORIAL

For the coming year, the twice-a-week service of the HEARST-SELIG NEWS PICTORIAL will be increased and extended to an even greater condition of efficiency. Additional bold, clever and intrepid camera men have been sent to the scenes of war, so that there are now experienced news picture gatherers with every important division of each of the warring nations in camp, in trenches, on battle ships, with aviation and balloon forces, etc.

As heretofore, the HEARST-SELIG NEWS PICTORIAL will be released for the benefit of exhibitors every MONDAY and every THURSDAY.

A HAPPY AND PROSPEROUS NEW YEAR TO ALL

THE SELIG POLYSCOPE COMPANY**EXECUTIVE OFFICES, CHICAGO, ILL., 20 E. RANDOLPH ST.**

THE HEARST NEWSPAPERS in Conjunction with THE
SELIG POLYSCOPE CO. PRESENT A WONDER-
FULLY SPECTACULAR HISTORY OF THE

WORLD'S GREATEST WAR

In Five Reels of Motion Pictures

A Tremendously Thrilling, Vividly Sensational and entirely
Authentic History of the Gigantic War now raging in Eu-
rope.

NOW READY FOR RELEASE THROUGH GENERAL FILM CO.

These Marvelous Motion Pictures were made on Gruesome
European Battlefields and in the Blood-running, fight-
ing trenches by the bold and intrepid Selig Camera
Men in co-operation with the fearless and efficient
Hearst Newspaper Correspondents who risked
their lives to obtain these authentic views.

**MOST SPECTACULAR MOTION PICTURES EVER
PRODUCED**

Five Reels of Exciting Battle Scenes—Greatest History of the
World's Biggest War.

New and Right From the War
First Real Battle Pictures Exhibited
Others have exhibited near war pictures photographed
after battles.

These are the only authentic and genuine war pictures actu-
ally filmed in battle.

Five exciting, thrilling, startling, vivid reels.

A special line of 4-color posters; one-sheets, three-sheets and
six-sheets. Order from your Exchange.

The Selig Polyscope Company

Executive Offices

Chicago, Ill.

20 E. Randolph St.

TRADE  MARK

The LASH of FATE



A stirring story of love and jealousy and the terrible mistake that brought tragedy into a woman's life. Many other great single and multiple reel pictures in the daily releases of the United Film Service. 43 exchanges.

UNITED FILM SERVICE (WARNER'S FEATURES, INC.) N.Y.

HAPPY NEW YEAR!



KEYSTONE

BRONCHO



8"-10" Photos of our Players can be had by sending to Publicity Dept 15 Cents for one - 50 Cents for set of 4

A WONDERFUL LOBBY DISPLAY

22"-28" Photo layouts in Character makeup of Trabel Normand, Chas Chaplin & Rescoe Arbuckle 20 Cents each



The Face on the Ceiling

Wednesday Dec. 30

MACK SENNETT
MANAGING DIRECTOR OF KEYSTONE COMEDIES
It is he whom we have to thank for all the Wonderful Keystone Successes of the past Year.

DOMINO

KAY-BEE



A Flower in the Desert

Thursday Dec. 31

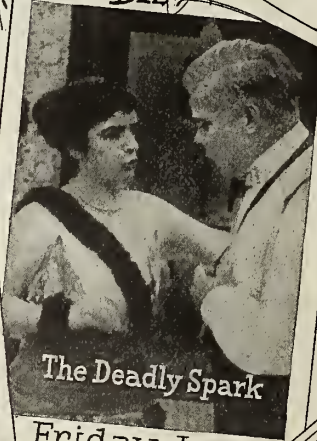

The Deadly Spark

Friday Jan. 1

Released Exclusively through the Mutual Film Corporation

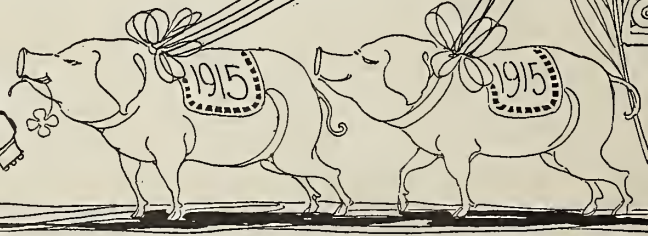

NEW YORK MOTION PICTURE CORPORATION

KESSEL & BAUMANN, MANAGERS.

LONGACRE BUILDING, 42^d STR. AND BROADWAY,

NEW YORK.



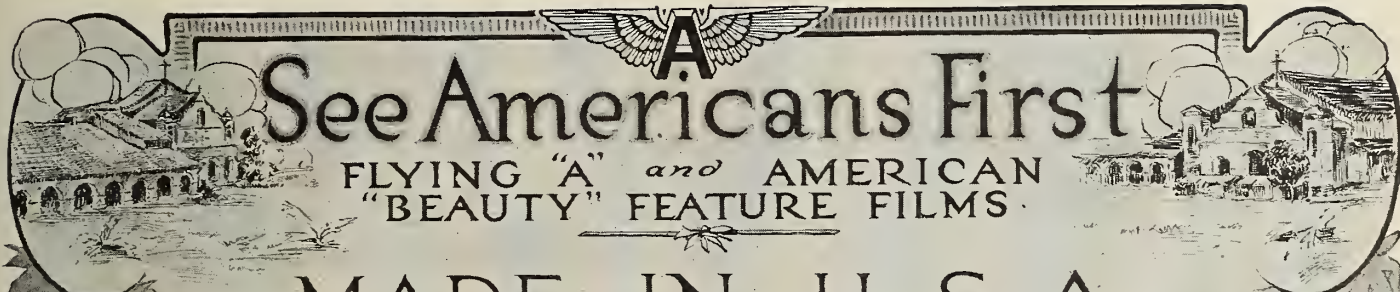

See Americans First

FLYING "A" and AMERICAN
"BEAUTY" FEATURE FILMS

MADE IN U.S.A.

The LEGEND BEAUTIFUL



An Adaptation of Popular Poem by
Longfellow.

Featuring VIVIAN RICH and an all
star cast.

Under direction
of
Thos. Ricketts.

Release
Monday,
Jan. 4th,
1915.
In Two Reels

AMERICAN BEAUTY FILMS

"IN THE VALE OF SORROW"

A tender, human interest story convincingly portrayed by cast of leading stars. Under direction of Frank Cooley. Release, Tuesday, Jan. 5.

"THE ALARM OF ANGELON"

Featuring WINNIFRED GREENWOOD and ED COXEN in a page from life among our alien friends.

Direction of Henry Otto. Release, Wednesday, Jan. 6.

AMERICAN FILM MFG. CO.
CHICAGO.

RUNAWAY

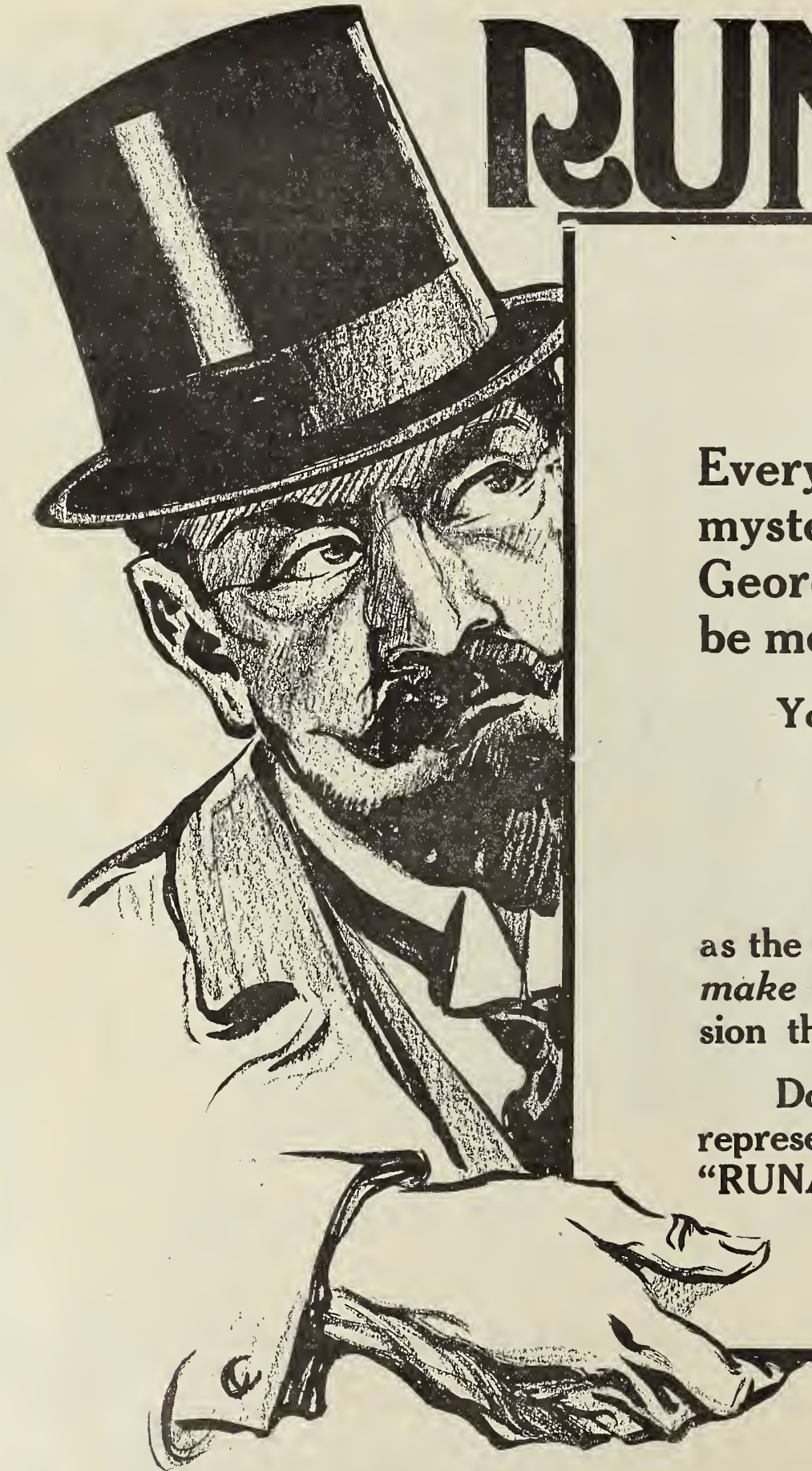

It Is

Every installment of the mysterious—more interesting—George Randolph Cheate be more mystified and

You will show something

“RUNAWAY”

as the theme and plot are calculated to make them think and talk about the sensation that at last the real story

Don't hesitate, but go to your local representative. No matter what you see in "RUNAWAY JUNE," the story

Book It—

SIR

RELIANCE

AWAY JUNE

Wonderful—

is great serial proves more subtle—more resting than the preceding one—as the story develops your audiences will more anxious to see the end.

ing new in a serial when you book

AWAY JUNE”

fferent than any serial shown heretofore. *It will* and go home with a pleased and happy expression has arrived.

the nearest Mutual Exchange now and ask for our that service you are using tell him that you want story that will appear in your local paper.

Bill It—and Advertise It Right



RIAL PUBLICATION CORPORATION

PRODUCED BY

MOTION PICTURE CORPORATION

29 UNION SQUARE, NEW YORK, N. Y.

The more YOU read these advertisements the more useful TO YOU we can make the "News."

PATHÉ

Announces the astonishing serial

The Exploits Of Elaine

to be released two reels weekly, first release

DECEMBER 28th

putting into pictures for the first time the greatest detective character of the day

“CRAIG KENNEDY”

In these episodes will be shown a criminal of a new and menacing kind, a man who utilizes strange forces and leaves no clue save the mark of a

CLUTCHING HAND

A new mark is set in thrills and intensity of interest.

MR. EXHIBITOR: Write or wire the nearest Eclectic Exchange at once for bookings.

THE ECLECTIC

110 W. 40th Street



FILM COMPANY

NEW YORK, N. Y.



THE EXPLOITS OF ELAINE



THE WORK OF THE CLUTCHING HAND!

A Powerful and Wealthy
Capitalist Struck Down
With No One Near: A Most
Modern Safe Opened By
a New and Terrifying Force:
The Super Criminal
has Arrived!

In this Serial is Revealed
Not Merely the Science
of the Present But of
The Future as Well!

BOOK IT NOW THROUGH THE NEAREST EXCHANGE OF
THE ECLECTIC FILM CO.



SOME REASONS WHY "THE EXPLOITS OF ELAINE" IS TRULY THE BIGGEST AND BEST SERIAL YET

THE CAST: Noteworthy in every respect. Arnold Daly and Sheldon Lewis from the "legitimate" with Pearl White, the ruling favorite of the screen. Directed by Leopold Wharton, "the man who knows how."

THE STORY: Written by Arthur B. Reeve, the only man who can unite science with fiction in a detective story that would enthrall a stoic. Dramatized by Charles Goddard, the famous playwright.

THE PUBLICITY: The stories will be published as issued in the great Hearst newspapers as well as the leading paper in each city in the land. The "Craig Kennedy" stories have run for four years in the Cosmopolitan Magazine with its enormous circulation. All the value of that colossal publicity is behind these thrilling episodes in which "Craig Kennedy" is a leading character.

MR. EXHIBITOR!

POSITIVELY THIS IS YOUR CHANCE IF YOU ACT AT ONCE! WITH PATRONS READY MADE FOR "ELAINE" IN YOUR TOWN IT'S UP TO YOU WHETHER YOU GET THEM OR YOUR COMPETITOR. WRITE, WIRE OR PHONE THE NEAREST ECLECTIC EXCHANGE FOR BOOKINGS.

ATLANTA61 Walton St.
DALLAS202 Andrews Bldg.
CHICAGO5 So. Wabash Ave.
MINNEAPOLIS109 Kazota Bldg.
NEW YORK115 East 23rd St.
BOSTON3 Tremont Row
LOS ANGELES114 E. 7th St.
ST. LOUIS3210 Locust St.
SAN FRANCISCO67 Turk St.
SYRACUSE214 E. Fayette St.
PITTSBURGH715 Liberty Ave.

CINCINNATI217 E. 5th St.
CLEVELAND622 Prospect Ave., S. E.
PORTLAND392 Burnside St.
PHILADELPHIA1235 Vine St.
NEW ORLEANS910 Gravier St.
WASHINGTON7th and E Sts., N. W.
KANSAS CITY928 Main St.
DENVER16th and Larimer Sts.
OMAHA1312 Farnam St.
SEATTLE810 Third Ave.
SALT LAKE CITY68 So. Main St.

THE ECLECTIC

110 W. 40th Street



FILM COMPANY

New York, N. Y.



A Liberal
Education in Itself
— that's

THE PATHE NEWS

See it and you'll see the same events of which your great grandchildren will read in their school histories. Show it and you'll show the oldest and best of all pictorial weeklies.

START THE NEW YEAR RIGHT

by booking the Pathe News—if you have not already done so. It's the investment that pays, the one indispensable film.



THE ECLECTIC FILM CO.

110 WEST 40th ST. NEW YORK CITY

"The Cream of the American and European Studios"





BEATRIZ MICHELENA



California Motion Picture Corporation

Executive Offices, San Francisco

Alex. E. Beyfuss, General Manager

GREATEST AND MOST BEAUTIFUL ARTIST NOW APPEARING IN MOTION PICTURES



As SALOMY JANE

in the play by that name adapted by Paul Armstrong from Bret Harte's romance and originally produced by Liebler & Company.



As MIGNON

in the world famous grand opera "MIGNON." The most satisfying story on the lyrical stage. An adaptation from Goethe's masterpiece "Wilhelm Meister." Scenario by Charles Kenyon, author of Margaret Illington's "Kindling."

As LOVEY MARY

in "Mrs. Wiggs of the Cabbage Patch." After Anne Crawford Flexner's dramatic version of Alice Hegan Rice's famous novels and produced through special arrangements with Liebler & Co.



"MRS. WIGGS OF THE CABBAGE PATCH," "MIGNON"
and all future productions distributed exclusively through

World Film Corporation

LEWIS J. SELZNICK
Vice-President and General Manager



**Extraordinary
Engagement**

WEBER'S THEATRE

Broadway at Twenty-Ninth Street

Continuous from 1 to 11 P. M.

**Beginning
Saturday
December 26th**

Should a Woman Divorce?

By IVAN ABRAMSON

A Powerful, magnetic photo-drama based on the most perplexing problem of the day.

An issue that affects the welfare of home, children and the human race.

A Play touching all sides of this vital issue, full of human interest, pathos and startling dramatic climaxes.

A dramatic story of marital difficulties so forceful, yet so naturally told, that its power often reaches a Biblical dignity.

It presents in vivid pictorial form the evils responsible for the upheaval of domestic relations and rests its case before the jury—THE PUBLIC

A vital national subject which gives food for all types of thinkers to decide the problem.

SINS of THE PARENTS (Five Reels)

Featuring the World's Renowned Tragedienne

Madam Sarah Adler
A Powerful Realistic Drama

Based on a

BIG THEME

Full of Gripping Situations and Dramatic Climaxes

**The Feature Which Has Proven
a House Jammer**

LIFE in the HOLY LAND (Six Reels)

**160 Scenes—Biblical—Historic—
Modern**

Showing the Life, Conditions and Customs of the Inhabitants
Today.

**FASCINATING—ENTHUSING
INSTRUCTIVE**

APPEALS TO ALL CREEDS, RACES and RELIGIONS

Packs the House. Fills the Till

EXCHANGES

IVAN FILM PRODUCTIONS, INC., 32 Union Square, New York.
Telephone 1292 Stuyvesant. For Greater New York, New York
State and Northern New Jersey.

NORTHERN FEATURE FILM EXCHANGE, 610 Schiller Bldg., Chi-
cago. For Illinois and Wisconsin.

McWILLIAMS & HENRY, PEERLESS FEATURE FILM EX., 824
Columbia Bldg., Cleveland. For Ohio.

THE CONSOLIDATED FILM CO., LTD., 295 St. Catherine Street W., Montreal; 62 Richmond St.,
East Toronto; 212 Phoenix Block, Winnipeg; 411 Leo Bldg., Vancouver, B. C. For Canada.

HYBAR FILM CORPORATION, Forsyth Bldg., Atlanta, Ga. For
North and South Carolina, Georgia, Florida, Alabama, Mississippi
and Tennessee.

MONARCH FEATURE FILM CO., 12th and Wyandotte Sts., Kansas
City. For Missouri, Kansas, Iowa, Minnesota and Nebraska.

NAT. A. MAGNER CO., INC., Fourth Floor, Pacific Bldg., San Fran-
cisco. For California, Nevada and Arizona.

STATE RIGHTS STILL AVAILABLE for all of the above features. Apply

Ivan Film Productions, Inc. Ivan Abramson 32 Union Sq., New York
President



PASSING 5¢ Admission · The Daily Change
 Cheap Houses · Destructive Competition
 Chaotic Conditions

OUR NEW YEAR'S WISH:

*Peace
 Prosperity and
 Progress
 to All.*



Paramount Pictures Corporation
 ONE HUNDRED and TEN WEST FORTIETH STREET
 NEW YORK, N. Y.

ALCO FILM

LIFE PHOTO FILM

PRES

AS SWEET AS
CLOVES YET
INTENSE AND
GRIPPING

THE PRIME
SOUTHERN
ROMANCE



SPRING

ALCO

ALCO FILM

210 W. 42ND ST.

CORPORATION

CORPORATION
ENTS

RELEASED
DEC. 28TH
ON THE
ALCO
PROGRAM

GETTIME

BY BOOTH TARKINGTON

WITH

FLORENCE NASH
WILLIAM H. TOOKER
AND SELECT CAST

CORPORATION
NEW YORK CITY

ALCO



*Important
Advance information!*

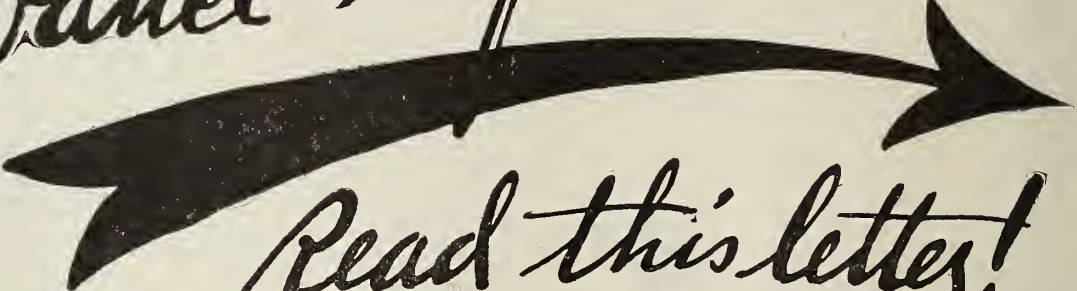

Read this letter!

ZUDORA

Thanhouser's Greatest Photoplay

Most Successful Photoplay Ever Staged!

ZUDORA is setting an attendance record that stamps it the greatest money-maker ever offered exhibitors. This wonderful serial photoplay is playing to **PACKED HOUSES** everywhere. 300 of America's most powerful newspapers are now running the serial story by Harold MacGrath. You can't afford to overlook an attraction like this.

Big NEW THRILLS Coming!—Book NOW!

Many remarkable scenes are now being staged for Zudora. There will be sensational surprises that will continue to keep up the tremendous interest shown. Helen Badgley—the 4-year-old Thanhouser Kidlet—will appear in an early episode. See the Thanhouser Syndicate Representative at any Mutual Exchange in America and book this big drawing card NOW!



Trade Mark Registered

Thanhouser Syndicate Corporation

71 W. 23rd Street, New York City

Produced by Thanhouser Film Corporation, New Rochelle, N. Y.

Producers of "The Million Dollar Mystery."



Trade Mark Registered

211





Executive Offices
71 W. 23rd Street
New York City

Thanhouser Syndicate Corporation

Distributor of
Thanhouser's Greatest Photoplay

ZUDORA

Story Appearing in the Leading Metropolitan Newspapers
Photoplay Showing at the Better Theatres Everywhere

Mr. Exhibitor:

Watch for sensational developments in the new episodes of "Zudora." The early episodes of this wonderful photoplay are constructed to lead up to some of the most remarkable pieces of acting in the history of motion pictures.

James Cruze, who is playing the leading masculine role in "Zudora," will be shown in a dual character, more powerful than that portrayed by Richard Mansfield in "Dr. Jekyll and Mr. Hyde." Mr. Cruze will show a dual personality in episode #7, from then on playing the part of the hero and the part of the villain.

The portrayal of the hero will be one of the most sensational things in motion pictures. In this part, he will eclipse his best as "Jimmie Norton" in the "Million Dollar Mystery."

The new sensations in "Zudora" will come with such startling rapidity and such a multitude of thrills that the public will be keyed to the highest pitch of expectancy.

We do not want to keep all the good things to ourselves; hence, we are letting you know, a little in advance, just what to expect on "Zudora."

This picture is breaking all records everywhere, and we intend that it shall set a new mark for photo serials.

Yours very truly,

THANHOUSER SYNDICATE CORPORATION,

W. E. Hallenburger
Vice President.

WES-M.

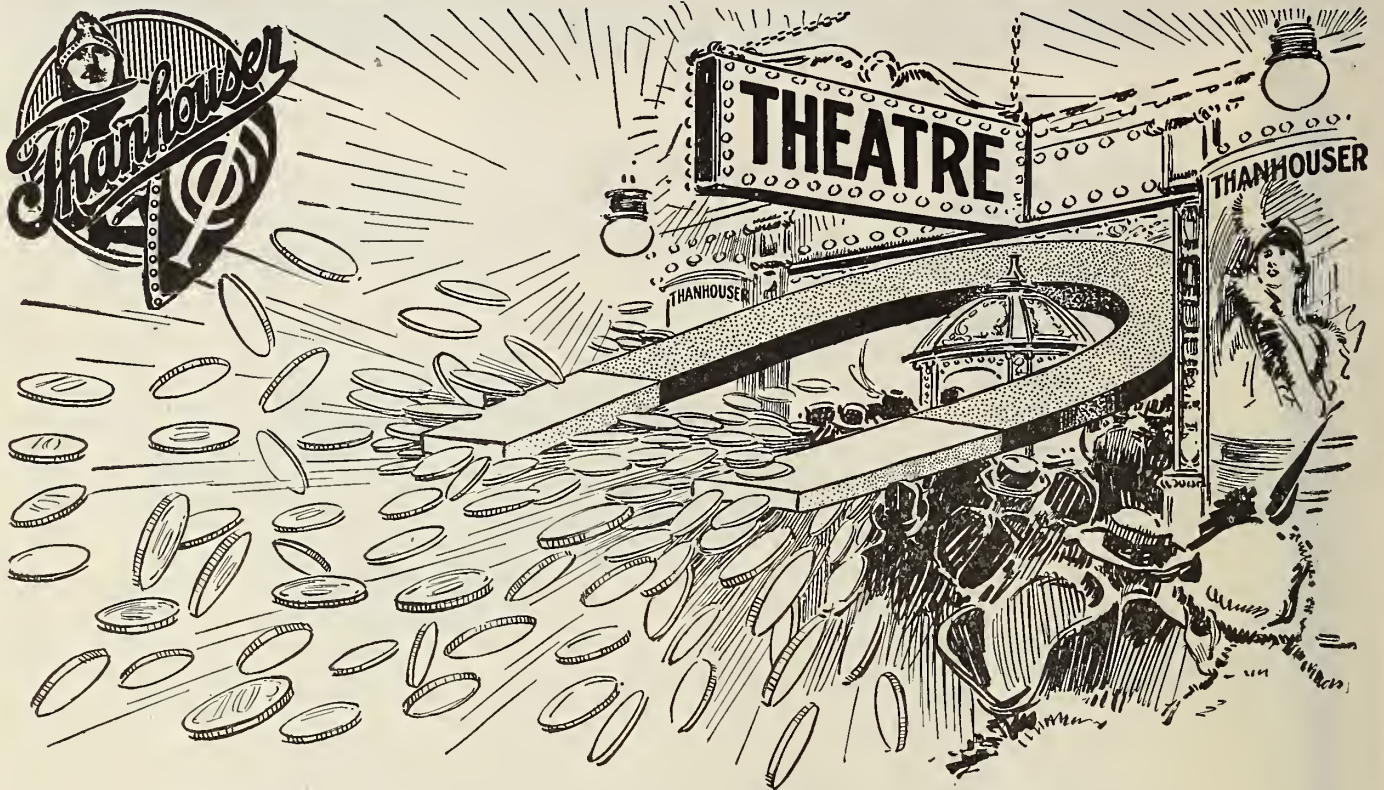

Thanouser Photoplays

Money Magnets For Exhibitors

“BIGGER box office receipts during 1915!” Let that be your slogan, Mr. Exhibitor. The first step in that direction is to book every regular release of the Thanouser Film Corporation. Get productions featuring such famous stars as Florence La Badie, Sidney Bracy, Mignon Anderson, Morris Foster, Helen Badgley and a host of others. Get productions that show elaborate settings, beautiful photography, expert direction. Get Thanouser photoplays—released exclusively through the Mutual Film Corporation in the United States and Canada.

Three-A-Week!

Three Thanouser productions are released each week by the Mutual Film Corporation. For the current week we announce:

Friday, January 1st—“Shep, the Sentinel.” A drama featuring the remarkable Thanouser dog “Shep.” The intelligence displayed by “Shep” is surprising. Reenie Farrington and Nolan Gane are also in the cast.

Sunday, January 3rd—“The Bridal Bouquet.” A romantic drama in which Mignon Anderson, Morris Foster and Ruth Elder play the title roles.

Tuesday, January 5th—“The Menacing Past.” A powerful two-reel drama of present-day life, featuring Mignon Anderson, Morris Foster and Mrs. Fairbanks.

Thanouser Film Corporation
New Rochelle, New York

"When You See It
In 'The News'
It's NEWS"

Motion Picture News

"The Exhibitors"
Medium of
Communication"

HAS THE QUALITY CIRCULATION OF THE TRADE

TEL. 7650 BRYANT

TWO HUNDRED AND TWENTY WEST FORTY-SECOND STREET

NEW YORK CITY

Volume X

JANUARY 2, 1915

Number 26

What the Exhibitor Wants

IT is said that the exhibitor is not responsive—that he does not write letters, for instance.

We do not find it so. We find, in fact, that he responds very cheerfully and freely—when he gets what he thinks is due him, and when he is particularly pleased over anything he wants others to know how he feels.

Many letters reach us right along; we have a file of several thousand. But the response to our Christmas issue is beyond all precedent. It is remarkable and will amaze you.

* * *

TWO hundred and sixty-eight letters and post cards have been received already and they are still coming in at an undiminishing rate!

I wish we had room to print them all. They are all interesting and instructive. But the few we print tell the story.

If you who read this page are interested in knowing what the exhibitor wants—and who in the trade is not?—you will find good practical food for thought in these printed letters.

* * *

FOR one thing, it is evident that the exhibitor wants a very *comprehensive* trade journal.

You cannot give him too much information. He is constantly asking for more. He is not satisfied with a few gossipy columns, or a mere department in a trade publication.

He wants all the many ground-floor facts, dates and first-hand information on the film and the theatres; and this means a considerable book each week—an *exclusive* book.

* * *

TO obtain this information the MOTION PICTURE NEWS employs a staff of nineteen persons in New York, managers and offices in Chicago and Los Angeles and regular salaried correspondents in sixty-seven centres in the United States and Canada.

We review pictures and endeavor fairly to appraise them—all in advance, and in three production centres; we publish release dates corrected at the last minute, often before the programme companies deliver release slips to their exchanges; and our staff correspondents comb every week—the entire country—for *live* news, *business* news, *exhibitor's* news.

* * *

ALL this service we give—and it is much service—for two dollars a year!

Exhibitors write us: "I do not see how you can do it." We could *not* do it—without our advertisers.

WE say this very frankly, and yet just as frankly we say to the advertisers: *this is an exhibitor's publication*; editorially it is devoted to the *exhibitors'* interests, not to yours. It is a *specialized* exhibitors' publication.

We say this, realizing fully our obligation—and the exhibitors' obligation—to the advertiser for making this publication possible. More than that, we say it in the advertisers' best interests.

* * *

WE owe service to the advertiser; and we give it. We give it by giving him circulation, and we can *only* give him circulation—*real* circulation—by producing an *exhibitor's* publication, a *specialized* exhibitor's publication. It is the *only* way.

That means a publication devoted exclusively to this trade and primarily and exhaustively to the exhibitor.

If there is any doubt in your mind that the exhibitor wants and expects such a publication and will have no other, it will pay you to read the following letters.

WILLIAM A. JOHNSTON.

* * *

Bluefield, W. Va., Dec. 9, 1914.

MOTION PICTURE NEWS, New York, N. Y.

GENTLEMEN: I certainly am reading MOTION PICTURE NEWS and expect to as long as I am connected with the moving picture business.

I have never had a trade paper that I liked as well, for the simple reason that it takes up every branch of the industry and shows more consideration to the exhibitor than any other paper.

It is full of live news each week and I certainly enjoy it. Kindly advise me when my subscription is up so I may renew it.

Very truly yours,
(Signed) RUSSELL S. WEHRLE.

* * *

Sisterville, W. Va., Dec. 17, 1914.

GENTLEMEN: Herewith enclosed we hand you check for \$2 for our subscription to your valuable magazine, the MOTION PICTURE NEWS. We are from that western state where people have to be shown, and after receiving the NEWS for some time past we have found it to be all you claim for it and more, for it is "*complete*" for the exhibitor.

In closing will state that the portrait reached us in good condition and it is the nicest work of the kind that it has been the writer's good fortune to look at.

Thanking you for the good you are doing for the business, we beg to remain,

Yours truly,
(Signed) O. F. LANGWORTHY.

Thee Show.

Abbeville, La., Dec. 15, 1914.

GENTLEMEN: I am in receipt of your Vol. 10, No. 24, enclosing color photo of Miss Blanche Sweet, and for both of which kindly accept my sincere thanks and congratulations.

This copy of your paper surpasses any that I have seen in beauty and in interesting matter.

The picture of Miss Sweet is all that the name implies and one could desire.

I would very much like to receive the NEWS and pictures like Miss Sweet's for a long, long time to come.

With my personal wishes to the NEWS for a Merry Christmas and a Happy and Prosperous 1915, I am,

Sincerely yours,

Prop. Victor Theatre. (Signed) A. O. LANDRY.

* * *

Ft. Dodge, Iowa, Dec. 14, 1914.

GENTLEMEN: Enclosed find \$2 for which enter our subscription to your valuable journal.

We received Xmas number and portrait and they were fine; in fact we do not see how you can do it for \$2 per. At present we are running a Merchant's Matinee and find it one of the best ideas we ever tried to build up the matinee. We have sixteen merchants who buy matinee tickets at 1 cent each and give them away to their customers.

We have used Universal films for the past year and find them first class and well worth the rental.

Wishing you a Merry Xmas, we beg to remain,

Yours very truly,

Empire Theatre. (Signed) ENGLE & MASON.

* * *

GENTLEMEN: Received Xmas issue of MOTION PICTURE NEWS, also the wonderful photo. Sure some class to this photo, and I assure you I appreciate the NEWS at all times, and want to thank you for the enclosed photo.

Wishing you all the success you deserve and compliments of the season, I am

Yours truly,

Lyric Theatre, (Signed) WILBUR D. INGLIDNE.

Marshalltown, Ia.

* * *

Cedar Rapids, Iowa.

GENTLEMEN: I wish to say that your MOTION PICTURE NEWS is much better for any exhibitor than any other picture journal. For one thing, your publication reaches me two or three days earlier. I get my MOTION PICTURE NEWS on Friday—nowadays you can't get any mail on Sundays—and I surely let all my work go and read your "News" from one end to another before I get through.

Crystal Theatre. (Signed) WM. HEMSKY, Prop.

* * *

New Bern, N. C., Dec. 19, 1914.

GENTLEMEN: We are pleased to acknowledge receipt of your December 19 Christmas Edition with enclosed photo which we both appreciated and admired very much, and wish to congratulate you upon this edition which was exceedingly thorough, interesting and clever throughout.

Very truly yours,

STAR AMUSEMENT CO., INC.,

Star Theatre. Per (Signed) F. M. Hahn, Mgr.

* * *

Waterloo, Iowa, Dec. 14, 1914.

GENTLEMEN: I think the MOTION PICTURE NEWS is there forty ways and then some. In regards to criticisms I have none to make. I get my NEWS two and sometimes three days earlier than the other weeklies, and appreciate it very much.

Yours truly,

(Signed) CHAS. E. VOORHEES,
702 Sycamore street, Waterloo, Iowa.

Pella, Iowa, Dec. 15, 1914.

GENTLEMEN: Allow me to express my appreciation. We look forward to the MOTION PICTURE NEWS and I read it and find it a great benefit and am well pleased with same.

Again thanking you for giving the moving picture industry such an excellent magazine, wishing you an abundance of success, I am,

Sincerely,

(Signed) P. G. VAN HOUWELING, Mgr.
Electric Palace.

* * *

Portland, Ore., Dec. 9, 1914.

GENTLEMEN: We recognize the MOTION PICTURE NEWS as one of our greatest assistants, and can assure you that as far as this office is concerned, as a publication it is deeply appreciated, and more than that it is indispensable.

The advance notices concerning features, as well as descriptions giving names of those film artists who are featured, is valuable beyond measure. I wish I had the time to write more.

Yours very truly,

NATIONAL AMUSEMENT COMPANY,

(Signed) MELVIN G. WINSTOCK,

General Manager.

* * *

Centralia, Mo., Dec. 12, 1914.

GENTLEMEN: I would recommend the NEWS to any person. I remain,

Yours truly

City Opera House. (Signed) MR. HAROLD PARKS.

* * *

Owasso, Mich.

GENTLEMEN: Your Christmas number of MOTION PICTURE NEWS received, and will say that it is very nice, artistically gotten up and full of wide-awake news, accompanied by a beautiful portrait of the high class order.

Success! (Signed) B. L. CONVERSE.

Temple Theatre.

* * *

Lawrence, Kan., Dec. 14, 1914.

GENTLEMEN: Enclosed find check for subscription to MOTION PICTURE NEWS. Have perused each number received very carefully, and can commend your efforts in giving to the exhibitor a journal devoted to their interests, and I hope they appreciate it as much as I do. It is a difficult matter to please all at all times in all things, and you are producing a magazine that meets reasonable demands in as clear, concise and conservative a manner as possible.

With best wishes for success of the MOTION PICTURE NEWS and your prosperity, I am

Yours,

(Signed) CLAIR M. PATEE.

* * *

La Porte, Ind., Dec. 12, 1914.

GENTLEMEN: In regards to portrait and magazine, must say that the photo is a dandy and your paper as good as any, if not a little better. I received photo in good condition.

Yours truly,

The Princess Theatre.

W. H. ESCH.

* * *

Centralia, Ill., Dec. 9, 1914.

I am more than pleased with the MOTION PICTURE NEWS. I consider it the brightest and newsiest picture magazine that I have ever had in my office.

Yours very truly,

Gem Theater.

(Signed) H. M. FERGUSON.

* * *

Gary, Ind., Dec. 9, 1914.

GENTLEMEN: I find the NEWS the most interesting of them all.

Very truly,

F. & H. Amusement Co., Inc. (Signed) V. U. YOUNG.

State Leagues Prepare to Fight Trade Evils

Michigan Exhibitors in Session at Detroit Will Grapple with Spreading of Free Coupon System—New Hampshire League Will Resist Adverse Legislation—Harrisburg Convention Will Meet When Legislature Opens—Maryland League Takes Up Poster and Film Rental Questions

Special to MOTION PICTURE NEWS

Detroit, Mich., Dec. 22.

SOMEWHAT disappointing was the attendance at the semi-annual meeting of the Michigan Motion Picture Exhibitors' League, which took place Tuesday afternoon, December 15, in the Equity building club rooms. However, what there was lacking in attendance was more than made up in the enthusiasm and interest manifested by those present.

The first regular business was the election of J. C. Ritter, proprietor of the Boulevard theatre, Detroit, to serve as vice-president of the national association representing Michigan.

Peter J. Jeup, president of the Michigan association, then gave an interesting report of the recent meeting held in New York of the executive committee of the M. P. E. L. of A., which he attended.

Fire Marshal Bill Discussed

The question of having eliminated from the State Fire Marshal bill the clause which calls for the inspection of moving-picture theatres semi-annually, was brought up for discussion, and it was unanimously resolved that the legislative committee of the League use their influence and every effort at the coming meeting of the state legislature to have this part of the bill abolished. The two inspections by the State Fire Marshal's Department, which cost the exhibitors \$10 each time, are entirely unnecessary, according to Mr. Jeup and association members.

President Jeup then announced the appointment of the following committees: Constitution and by-laws, H. E. Fowser, Adam J. Orth and Mr. Bumler; legislative committee, Peter Jeup, Detroit; Mr. Smith, of Grand Rapids; Mr. Mueller, of Howell; and Messrs. Neal, Cady, Hall, Abel and Jarvis from Lansing.

A committee composed of exhibitors in Lansing was appointed to make local arrangements for the annual summer meeting, which will take place June 8 at the Capitol City.

Take Up Intermission Question

There was considerable discussion on the law recently passed in Boston, compelling exhibitors to allow an intermission between each 1,000-foot reel, which is said to relieve eye-strain. Detroit exhibitors feel that in the near future, either locally or at the state legislature, some bill will be presented along similar lines, and it was the purpose of Mr. Jeup to get expressions from the members on this subject.

Opinions were divided. Some were in favor of two minutes, others three minutes, some none at all, and a few five minutes. No definite action was taken, but the matter was referred to the legislative committee for attention.

Just before adjournment, several of the members asked what course to pursue to meet the offers being made by competitors in the way of coupons good for another theatre. The fact was brought out that a deplorable state of affairs in the matter of "free coupons" and "cheap coupons" existed in Bay City.

Coupon Evil Is Invading Michigan

One party who owns a number of theatres gives a coupon, good, with every regular admission ticket, which with five cents is good for admission to one of his other ten-cent houses. There is one certain house that is not giving any coupons, but is trying to conduct its business in the regulation way, but he wanted to know what to do, whether to put up a fight or leave it to the association to straighten out. The man finally said that if by January 1 the coupon scheme is still being practiced, he will go his competitor one better.

In the city of Detroit there are also a number of cases where exhibitors are selling coupons below the regular price to merchants, who give them away free, gratis, in connection with wrappers and labels from their goods.

In fact, it is surprising how fast this sort of thing is developing. Not a day goes by that some exhibitor does not have presented to him such a proposition, either by a retail grocer, baker or retail merchant of some kind.

Despite all that the association is doing, as well as its committees, to eliminate evils, it is surprising how fast new ones are

constantly creeping in. One thing that makes it difficult is the fact that many exhibitors are not members of the association, and naturally they do just as they see fit, and there is no way to control them. Many of them get films from outside the state, so that the Michigan exchanges have no means of forcing them to live up to the ethics of the association.

The Michigan association now has a membership of approximately 160 exhibitors; close to 30 members have joined since December 1.

New Hampshire League in Enthusiastic Session; Bean Elected to Head Organization

Special to MOTION PICTURE NEWS

Boston, Dec. 22.

WITH about 30 of the 72 exhibitors in the state present, and letters received from a dozen others expressing their willingness to join, the Motion Picture Exhibitors' League of New Hampshire was formed at an enthusiastic meeting held on Friday, December 18, at the Eagle Hotel, Concord, N. H.

The organization is mainly the result of the efforts of Charles Bean, of Franklin, who has worked for weeks to bring it about by means of personal visits and letters sent to every part of the state. It is patterned after the Massachusetts league, to embrace not only actual exhibitors, but persons connected with every branch of the motion picture industry.

Seven members of the Massachusetts league went up from Boston and all of them spoke to the gathering, explaining how the Bay State organization was formed and how it is conducted. They were President Ernest H. Horstmann, Harry F. Campbell, manager of the New England office of Box Office Attractions; J. A. Eslow, manager of the New England Universal Film Exchange; Fred B. Murphy, manager of the New England office of the United Film Service; E. J. Farrell, of the General Film Company; Thomas Spry, of the Alco, and Charles W. Hodgdon, of the Princess theatre, Wakefield. All of the Boston men joined the newly formed league as representatives of exchanges supplying the New Hampshire trade.

Charles Bean Elected President

The meeting was preceded by a luncheon. Charles Bean, of the Pastime theatre, Franklin, had charge of the affair and was elected president of the organization for the coming year. The other officers chosen were: Vice-president, Jacob Conn, of Concord; secretary, Manuel Lorenzen, of Manchester; treasurer, A. L. Couture, of Manchester. Executive committee, G. D. Barrett, of Dover, chairman; W. J. Dupont, of Berlin; George L. Pierce, of Manchester, and F. W. Hartford, of Portsmouth.

While no direct mention was made of the fact at the meeting, the new association is confronted with a great deal of adverse legislation at Concord, and exhibitors all over the state, now welded into a body, are determined not only to oppose all attempts to injure their business, but to have placed on the statutes a few ideas of their own for the uplift of the industry.

The organization went on record as opposed to Sunday shows in the state. In the near future the association will be incorporated under the laws of New Hampshire. The next meeting will be held in a short time at the call of President Bean.

Postpone Harrisburg Convention Until Legislature Meets; Poster Restrictions Arouse Anger

Special to MOTION PICTURE NEWS

Harrisburg, Pa., Dec. 22.

ANNOUNCING that the reason for changing the date of the convention to be held in this city of representatives of all the various detached organizations of motion picture exhibitors for the purpose of forming a statewide body, from January 4, 5 and 6 to January 26, 27 and 28, is so that it will come after the State Legislature is in session and is fully organized. James Delves, secretary-treasurer of the Motion Picture Exhibitors' Association of Pennsylvania, has just sent out a circular letter from

Pittsburgh to theatre men in all parts of the state. This is the association which has taken the initiative in calling the convention.

Mr. Delves says that there already is assurance that from 600 to 800 exhibitors will be at the convention and that the sole purpose of the proposed statewide organization is to defend the motion picture business from "present and proposed legislation." The principal sore spot that rankles in the breasts of the Pennsylvania exhibitors appears to be the censorship law, which became effective last June and which the exhibitors hope to have repealed in the coming session of the Legislature.

Poster Restrictions Cause Complaint

There has been a good deal of complaint among theatre men regarding the disposition of the present board of censors to try to limit the size of posters that are used, and in this connection the circular says, "It will be impossible for us to book any multiple features or masterpieces, as the law at the present time denies us the right to use any advertising matter larger than a three-sheet, and it is being enforced throughout the state."

The assurance that prominent motion picture men declare has been given by United States Senator Boies Penrose, the recognized leader of the dominant Republican organization, that he will give his aid in repealing the censorship law, is encouraging to the trade. The feeling seems to prevail, however, that to obtain the desired repeal, even with Senator Penrose's aid, it will be necessary for the exhibitors of Pennsylvania to show a united and solid front. It is believed, therefore, that by postponing the date of the convention until the latter part of next month, when the Legislature will have passed through the early stages of organization, a more effective demonstration can be made to influence the law-makers to recognize the justice of the contentions of the motion picture men.

Poster and Film Rental Questions Come Up Before Maryland League At Next Regular Meeting

Special to MOTION PICTURE NEWS

Baltimore, Dec. 23.

MEMBERS of the Maryland branch of the Motion Picture Exhibitors League of America will hold several meetings next week. On Tuesday afternoon the executive committee of the League will hold a meeting at which reports will be formulated to be submitted to a general meeting of members, which will be held Tuesday night.

One of the matters which will receive attention is an agreement between the exhibitors and the motion picture operators' union. Members of the executive committee have been at work on a contract applicable to both the exhibitors and the union. It has taken several months to straighten the matter out, but now the plans are in such shape that it is thought that they will go through without a hitch.

The proposition that exhibitors will be compelled to rent posters from some of the film distributors is meeting with a great deal of opposition in Baltimore. The executive committee has taken a strong stand against this move on the part of the distributing companies and there is no doubt that the report will be unanimously endorsed at the meeting of members on Tuesday.

Suggestions are made in the report to remedy the plant to rent films, but just what the details of the plan are is being withheld until the exhibitors have an opportunity to try out their proposition.

MASTERPIECE BUYS LOFTUS STUDIO

Special to MOTION PICTURE NEWS

Los Angeles, Dec. 21.

NEGOTIATIONS have been completed by the officers of the Masterpiece Film Manufacturing Company for the purchase of the motion-picture property known in Los Angeles as the Loftus studio, located at 1339 Gordon street, and plans have been prepared for a substantial steel and concrete studio building, with laboratories having a capacity sufficient to meet the requirements of the company for months to come.

The lot is 300 x 350 feet and the plans call for a building covering the entire area, at an approximate cost of \$60,000. The stage will be inclosed with glass, equipped with Winfield-Kerner electric lighting system, have an aquarium, moving perspective, rotating platforms, and other new features.

The improvement is in charge of Frank C. Hill, secretary and treasurer of the company; Max Figman, producer, and Elliott Clawson, scenario editor.

NEW MERGER WILL RELEASE THROUGH UNITED

Special to MOTION PICTURE NEWS

Los Angeles, Dec. 21.

ANOTHER motion picture company is being organized, and it is hinted there will be a merger of this and another at a little later date, and then all the products of the company will be released through the United Program, successors to Warner's Features.

W. A. Brooks, owner of the big Western outfit, consisting of more than a hundred horses, a herd of Western cattle, ox teams, saddles, guns, etc., formerly used at the New York Motion Picture Company studio, is at the head of the new company, and has interested the Millers of 101 Ranch fame.

Burton King, now with the Universal, but formerly director general of the Usona Company, will be at the head of production, and Adele Lane, for the past two years with Selig Polyscope Company as leading woman, has been engaged.

What company or companies will be merged with this new organization has not been given out, but those at the head of the organization believe public announcement will be made in the near future and production work begun about the first of the year.

SPOKANE EXHIBITORS START ANTI-WHITE SLAVE FILM CRUSADE

Special to MOTION PICTURE NEWS

Spokane, Dec. 21.

FOLLOWING a recent conference in Spokane, a number of picture exhibitors and other theatrical men throughout the state are prosecuting a campaign to discourage the use of white slave traffic photoplays and road shows of that nature.

Those who are behind the movement and who were present when the plans for it were brought up here are J. Beck, Pullman; Eugene Levy, Seattle; Herman J. Brown, North Yakima; J. E. Ferguson, Wenatchee; George L. Baker, Portland; L. E. Chandler, Aberdeen; George St. Peter, Everett; J. Sutherland, Bellingham; William Simpson, Leavenworth; Clarence Summerville, Pullman, and H. S. Clemmer, Dan Weaver and Charles York, Spokane.

LICENSE LAW PLANNED IN INDIANAPOLIS

Special to MOTION PICTURE NEWS

Indianapolis, Dec. 15.

AT a recent meeting of the city council Monday evening, Councilman Edward R. Miller introduced an ordinance to license all amusements and entertainments for gain or advertising purposes. It divides amusements and entertainments into twenty-one classifications and requires application for license to be made to the mayor. School and church entertainments where an admission fee is charged would not be exempt. The license fee for such entertainments would be \$5 a day.

Moving picture theatres, under the ordinance, would pay from \$26 to \$150 a year, according to the hours the places are open and admission charged, the maximum admission fee charged at any time during the year to govern the cost of the license.

BOSTON BUILDING LAW FIGHT BEFORE COURT

THE case of the new Park theatre, Boston, comes up in the Superior Court this week when Mayor Curley and Building Commissioner O'Hearn will seek to have the house closed up for alleged violation of the recently enacted ordinance which provides that motion pictures shall be shown only in buildings of first class construction.

The theatre, after being remodeled at a cost of more than \$50,000, opened on December 7 and has been running picture shows since in spite of the order from City Hall.

AN ENGINEER COULD RUN SAFELY WITHOUT ANY SIGNALS—

sooner than an exhibitor could safely get along without full and complete release date charts.

That's why the exhibitors who take MOTION PICTURE NEWS wouldn't give it up for any consideration.

The Permanency of the Motion Picture

By **THOMAS H. INCE**

Vice-President and General Manager, New York Motion Picture Corporation

The Lasting Qualities of the Business Depends on the Producers Alone, But the Pictures Must Have the Same Diversity of Subjects as Daily Newspapers, Combined with Artistic Standards and Technique
—Cheap Melodrama and Dearth of Good Scenarios a Menace to the Business

THE faddists are at it again. With every ounce of poundage at their command they are trying to make us believe that the swan-song of the motion picture soon will be lifted through-out the land. Already some of them are speaking of motion pictures as ancient history.

On the contrary, and speaking from observation and experience, I can say without reserve that those who are not in sympathy with motion pictures are those whose necks still are encircled by millstones which they would like to shake off if they could do so without loss to themselves.

Faddists never die without a struggle and those few remaining ones tentacled to the drama cannot be blamed for not wishing to prepare their own petard. Within the past several years as many of them as could have deserted the drama for the more lucrative motion pictures. Few have returned to the drama.

General Exodus from the Stage

Within the past year there has been a general hegira of all branches of the theatrical world to motion pictures. I predict that it is only a question of time when motion pictures will supersede everything else in the amusement world. Everything points to it.

To one who understands the qualities of human nature and who is experienced in the ways of providing it with subjects which go to make up human interest, there can be no doubt of the future of motion pictures.

One of the best arguments is the diversified field of picture making; embodying everything in which the mind is interested. Human interest is everything on this planet. Without it the four billions of earthly bipeds soon would surrender to despair.

One of the first things an editor will tell a cub reporter is to bring in a human interest story—something snappy and with plenty of action to it, and, above all, something in which we can see ourselves reflected, whether it be meritorious or otherwise. That is the make-up of a newspaper—a daily journal of human interest happenings culled from the four quarters of the globe.

Depends on Producers Alone

The permanency of motion pictures depends upon the producers alone. Just as long as they can picture scenes of human interest and supply enough variety to keep the public mind focused on moving pictures, just so long will motion photography retain its vitality. It must have the same diversity of subjects as the daily newspapers, together with proper technique and the loftiest standards known to the art.

Cheap melodrama is one thing which is proving a menace to the permanency of the motion picture. In my opinion it is something which the public tolerates rather than enjoys, and the quicker it is eliminated the better it will be for the craft.

Time and proper censorship in each community will undoubtedly correct this evil, but it is to be regretted that certain producers still believe the public to be extremely gullible, when, as a matter of

inexperience and other kindred reasons. But wonderful reforms have swept aside many of the evils, and we who are on the ground already see far more wonderful things ahead in this busy, fascinating world of picture-producing.

Lack of Good Scenarios

One of the principal faults with which we have to contend has been the lack of good scenarios. In late years there has been an enormous demand for films and this demand is still growing at an unprecedented rate. The result has been that thousands of poorly written scenarios have been filmatized in order to supply the demand.

We want scenarios of original plot and harmonious construction and are willing to pay well for first-class productions—scenarios teeming with human interest and chuck-full of action. You must utilize judgment and discrimination and scenario writing as in any other legitimate pursuit.

For instance, you can't deify an Italian organ-grinder any more than you can make a hero out of an undertaker, as a young Californian lad did some time ago in a scenario sent me.

The field of human interest from which to draw is practically limitless, and any person of ordinary education and intelligence and with a good imagination can write a scenario.

The main fault lies in the padding thereof. Boil interesting, vital facts down to a thick consistency, classify the chief events, and you have a scenario of which any producer should be proud.

WHERE TO FIND IT	
Department.	Page.
Live Wire Exhibitors.....	31
In and Out of Los Angeles Studios	35
Looking Ahead	33
Editorials	39
Among the Exchanges.....	37
Chicago News	41
Feature Reviews	43-48
Program Reviews.....	49, 50, 60
Last Minute News	51
Current and Coming Releases..	52, 53
Release Dates for Ready Reference	55, 56, 58, 59
ACCESSORY NEWS	103-116

fact, any observant person does not have to look twice to convince himself that cheap melodrama received the stamp of public disavowal a long time ago.

It may be said that motion picture producing still is in an embryonic state; that evils naturally have crept in due to

Deceased Pathé Vice-President a Film Expert

Arthur Roussel, Who Died at His Home in West New York, N. J., After Protracted Illness, Grew Up in the Business

ARTHUR ROUSSEL, former vice-president of Pathe Freres and a leading authority on all technical matters pertaining to film manufacture, died at his home in West New York, N. J., after a long illness. The funeral was held at his house on December 16, many prominent men being present, among them Charles Pathe and Louis Gasnier, of Pathe Freres.

Mr. Roussel was only thirty-four years old at the time of his death, but in experience in the film business he was equaled by few. Starting in with Pathe in France while only a boy he had seen the development of the motion picture from the very start. In 1910 he was sent to the United States and placed in charge of the Pathe factory at Bound Brook, N. J.

After some 18 months he was transferred to the studio in Jersey City and about a year ago when the Eclectic Film

Company was formed was placed at the head of that business. Early this year when Mr. Berst resigned his position as vice-president of the Pathe American company, Mr. Roussel was honored with the office, holding it until his resignation this fall because of illness.

Mr. Roussel was an expert photographer and knew film manufacture as do few men. His kindly, cheerful nature made him genuinely popular with all who came in contact with him. He leaves a widow and infant son.

BERANGER, MADE DIRECTOR, WILL PRODUCE "BABY'S RIDE"

George A. Beranger, formerly D. W. Griffith's assistant, has now been made a full director, and his first production for the Mutual program will be "The Baby's Ride."

CANADA MAY RAISE DUTY ON FILMS

Special to MOTION PICTURE NEWS

Toronto, Dec. 23.

A persistent rumor has been going the rounds that the Dominion Government intends to raise the duty on film from 25 to 50 per cent. This is going to work a great hardship on the small exhibitor, who is paying at present all he can afford for service. If this rumored change takes place some one has got to pay the difference, and it is very unlikely the exchanges will consent to bear the extra cost without charging more for the same service. It is impossible to get in touch with any of the officers of the motion picture association to find out if they intend taking any action to protect themselves against this hold-up. So far as can be learned, the association has become a thing of the past.

MARGUERITE CLAYTON LEAVES ESSANAY

Special to MOTION PICTURE NEWS

San Francisco, Dec. 21.

Marguerite Clayton (who is in private life Miss Marguerite Fitzgerald) resigned her position as leading lady for the Essanay Western Company, at Niles, Cal.

Miss Clayton has signed a contract with the Liberty Film Company at San Mateo, Cal., to play leading roles in a number of feature films that will be produced at the San Mateo studios.

Carl Stockdale, Emery Johnson and Vera Hewitt, formerly with the Niles Company, are already at work with the San Mateo concern.

True Boardman and wife, who is known professionally as Virginia Ames, resigned their position with the Essanay Company and are connected with the Liberty.

LEN SPENCER DIES SUDDENLY

Len Spencer, founder of Len Spencer's Lyceum, one of the best known theatrical agencies supplying operators, musicians and singers to motion picture theatres throughout the country, died suddenly last Wednesday, December 16. The agency at 245 West Forty-second street, New York City, will continue under the direction of Henry Spencer, brother of the deceased.

New Home of Kriterion Nearing Completion

Offices Occupy Sixth Floor of Mecca Building, and Are Well Lighted and Very Attractive—Clements Predicts Good Business

THE new home of the Kriterion Programme is fast being put into shape on the sixth floor of the Mecca building at 1600 Broadway. The offices are those formerly occupied by the Kinemacolor Company, but are being entirely remodeled to suit the needs of the new tenants. One of the important features is the projection room, long regarded as one of the finest private theatres in the film trade.

This will be put into the best condition for showing Kriterion pictures. The new offices cover the entire sixth floor, and have an outlook on Broadway, Seventh avenue and Forty-eighth street, thus affording unusually well-lighted and attract-

ive quarters. The furniture throughout is mahogany.

B. E. Clements, vice-president and general manager, in commenting on the outlook for the coming year, predicted one of the biggest and best seasons yet seen in the film industry. The policy of his company, he said, would be, as already stated, to put on a program of good stories, well produced, and to co-operate with the exhibitor. The producing companies are all hard at work getting films ready for release, and many reels are already on hand. All of these have proved on examination to be of excellent quality, and the future of Kriterion appears to be a rosy one.

Mary Pickford Not to Leave Famous Players

Popular Star Puts Quietus on Rumors and Declares That She Cannot Consider Any Other Course Than to Remain With the Company

MARY PICKFORD, the world's most famous motion picture star, who has a greater universal following than any actress in screen history, and who, it has been generally rumored, contemplated leaving the Famous Players Film Company, in whose productions she has



MARY PICKFORD

exclusively appeared for the past two years, has finally denied the truth of these reports and authoritatively contradicts the supposition that she is entertaining any plans of severing her connection with the Famous Players.

Miss Pickford states:

"I am very thankful for the numerous and flattering offers recently extended to me, but I sincerely believe that I cannot conscientiously consider any other course than to remain with the Famous Players Film Company. The high artistic standard of this company and its constant efforts to elevate and dignify motion pictures place it conspicuously in a position of being the most serious film producing company in the world.

"The plans the Famous Players have made for the future even transcend the importance and distinction of their past achievements, and I am certain that my continued association with this company

will provide greater opportunities for distinctive film creations than could be offered by any other factor in filmdom.

"I owe the public who have so splendidly supported and encouraged me throughout my entire career, careful consideration of this important point, and I feel that in extending my affiliation with the Famous Players, I can best repay, in some small measure, the thoughtful regard that the public has so often demonstrated for the higher element of film offerings.

"I am grateful to Adolph Zukor, Daniel Frohman and Edwin S. Porter, officers of the Famous Players Film Company, for all they have done for me toward the best selection and presentation of my plays, and I know they represent, in the highest degree, the spirit of advancement that permeates the art of the photoplay."

Mary Pickford began her phenomenal career as a film star several years ago, and throughout her entire association with the screen she has enjoyed an amazing degree of popularity. She is idolized by millions of people all over the civilized world, and is considered the greatest personal attraction in theatrical history. She began her connection with the Famous Players Film Company two years ago, shortly after the inception of this concern.



MARY PICKFORD IN "CINDERELLA"

Previous to this, she had been selected by David Belasco to create the role of Juliet, the blind little heroine of his famous production, "A Good Little Devil." When the Famous Players Film Company arranged with David Belasco to reproduce "A Good Little Devil" in motion pictures with the entire original cast, "Little Mary" found herself in the unique position of a famous film star leaving the screen to attain a great stage triumph, and returning to motion pictures in the role which won this new distinction. After the completion of the film version of "A Good Little Devil," Mary Pickford was induced by the Famous Players to remain with them, in whose productions she has appeared uninterrupted throughout this entire period.

LIVE WIRE EXHIBITORS

EDITOR'S NOTE.—It is the desire of "Motion Picture News" to include under this heading novel advertising ideas, successful schemes in the management, decoration and equipment of the theatre—everything, in fact, done by the exhibitor to stimulate his trade. We invite every exhibitor to write us about any new enterprise he has; also to come to us for advice or information along any line. Address: Editor, "Motion Picture News," 220 West Forty-second Street, New York City

FASCINATION OF \$10 GOLD PIECES

SATURDAY and Sunday matinees are especially successful in Butte. Each theatre has two ladies' days in the week when a \$10 gold piece is given to the lucky lady holding the right number.

As a general rule, however, there are new stunts tried by the managers. The patronage is steady. The managers advertise liberally in the daily papers, securing liberal space for free readers in proportion to the size of their advertisements.

For a 10-inch double column advertisement the theatre is allowed a reader of some seven inches long. Each theatre employs a press agent, changes its shows two, three and sometimes four times a week. The rate paid for advertising is small compared with the big cities, 50 cents an inch with the compliment of the free reader and space at all times for good cuts and illustrations.

The Sunday papers give extra space and room for the calendar for the week without extra charge. No paper maintains a special theatrical man but the editors are very liberal in their treatment of the press agents and it is seldom that one is refused the publication of anything that looks like a story.

FREE TRIP POPULARITY CONTEST TO FILL THEATRE

A POPULARITY contest which has been the means of packing the house has been inaugurated by the management of the Ideal Theatre, Louisville, Ky.

This house is in a thickly populated section and several of the residents have entered the contest with the result that their friends have become daily patrons, each ticket being good for a vote. The contest will run for several weeks.

Since the contest started the receipts have increased considerably. A trip to the Panama-Pacific exposition and a piano are among the prizes offered.

"STUDENT MATINEES" A DRAWING CARD

MANAGER ERDMANN, of the Elmwood theatre, Buffalo, N. Y., is meeting with unusual success with his "student matinees" which he holds every Saturday afternoon from 2-5 o'clock, presenting all the latest scientific, travel and literary films on the market.

These matinees are widely advertised among the schools and are very popular with the students.

BRINGING "LOCAL COLOR" TO YOUR PATRONS

DESPITE the amusement slump which has gripped Arizona following the British contraband of war on copper, the big product of the state, enterprise has shown that a feature properly handled will get results in the face of any sort of depression.

Walter B. Leecraft, Phoenix, Arizona, secured for his mid-week feature at the Lion theatre the "Wrath of the Gods," and not content with billing it like a circus, he decorated his entire house with Japanese wistaria and native roses, just now in bloom there.

The effect was heightened by cleverly designed Japanese lanterns which, placed over the house and exits lights, gave the foyer of the theatre a decided Nippon atmosphere. Incidental to the screening of the picture his orchestra rendered a program in which Japanese selections were the

feature. The lanterns used to cover the lights were designed by Mr. Leecraft from baskets and were supplied with characteristic Nippon artistry in the shape of faces done in colors on gelatine and inserted in clefts in the sides of the wickerwork.

The opening of each show was made more impressively Japanese by the burning of incense and the tolling of little Japanese sorrow bells. Not in the history of features in this section has a picture received such a lavish theatre setting, and the effort drew a business that well recompensed the outlay.

Mr. Leecraft marked an epoch here in submitting features, and the success of this the first attempt to inject atmosphere into a screen offering here will probably be the means of seeing more of the big things done with an attempt at really novel settings.

AUTOMOBILE FLOAT FOR "THE MASTER KEY"

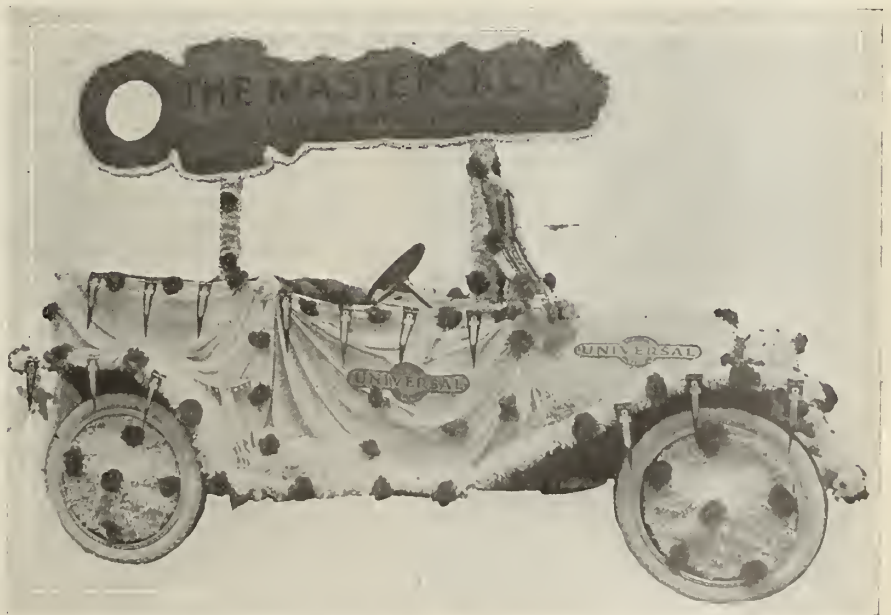

"THE MASTER KEY" CAR USED BY THE SAVOY THEATRE, ATLANTA, GEORGIA

WHEN it comes to using advertising stunts that are history-making, James F. Jackson, manager of the Savoy theatre, of Atlanta, may be put down in the front ranks as a man of stunning originality.

The accompanying picture shows how Mr. Jackson was represented in the big

"Hog and Hominy" parade. Expert designers, under his direction, made a float widely commented on as one of the most handsome in the parade, or any float, for that matter, seen in an Atlanta parade for some time.

Incidentally, Mr. Jackson showed the Universal picture to packed houses.

"ROSE OF THE RANCHO" GRAPE VINE 144 YEARS OLD

Millions of people who are destined to witness the Jesse L. Lasky production of David Belasco's dramatic hit, "The Rose of the Rancho," will doubtless comment on the beautiful grape arbor under which



UNDER THE OLD GRAPE ARBOR IN "THE ROSE OF THE RANCHO" (Lasky)

the villain, Kincaid, and his men plot the seizing of the various Spanish "ranchos."

It is well authenticated local history that this particular vine, which has grown to such wonderful proportions, was planted in the year 1770 or just before the Eastern States fought the war of revolution which freed them from England.

ILLNESS FORCES CLARKE, OF EDISON, TO RESIGN

Edwin Clarke, the popular young Edison player, who for the past four years has been associated with that studio, has resigned because of a serious illness which will require permanent residence in California's mild climate. His impersonation in the "Fantasma" film forms a splendid climax to his long service for the studio and it is remarked by his fellow players as being highly typical, in its boyish, winning grace of manner, of Mr. Clarke's own personality. Julian Reed, his friend for years, took Mr. Clarke to the train, as the representative of the studio, to wish him the speediest return to health, for he was beloved by all his co-players.

SECURES BRITISH RIGHTS TO LIFE PHOTO

Bishop, Pessers and Lorimore have secured the exclusive rights of all the releases of the Life Photo Film Company, for Great Britain and her colonies other than Australia and Canada. This is one of the many excellent programs that Mr. Pessers expects to close before sailing for Europe on December 30.

EDWARD ABELES IN "AFTER FIVE"

Edward Abeles has been re-engaged by the Jesse L. Lasky Feature Play Company to star in the release entitled "After Five," which is announced for January 28.

Ruth Roland in "Twelve Vital Questions of Life"

Actress Will Star in Dramas Instead of Comedies, But in Doing So Only Returns to a Former Field of Endeavor

RUTH ROLAND, the famous Kalem girl, began her association with the Balboa Company, of Long Beach, Cal., Monday, December 14, under the direction of Harry Harvey. She will be featured in the twelve prize productions involving twelve vital questions of life.

To the surprise of those high in motion picture circles Miss Roland will be starred in dramas instead of comedies. But she is not undertaking anything new to her. On the contrary, she is returning to the field of effort in which she scored her first successes.

In the "Twelve Vital Questions of Life" features Miss Roland's versatility will be heavily taxed. She will be called upon to interpret roles that require a combination

of all the splendid abilities she has so carefully cultivated, and for the first time the public will have an opportunity to see her in artistic blendings of comedy, pathos and tragedy.

Mr. Will M. Ritchey, one of the best known and most capable scenario writers in the United States, who has convinced the motion picture world that he is a real dramatist and a pastmaster of cinematographic technique, is giving his personal attention to the plays Miss Roland will appear in.

Some of these have been furnished by the foremost scenario writers in the country. Others are picturizations of popular novels, while the most powerful will be from Mr. Ritchey's own pen.

United Service Offices Altered at Cost of \$6,000

Space Occupied by the Exchange Handling Warner's Features Has Been Almost Doubled—Art Department in Specially Light Quarters

EXTENSIVE alterations in the general offices of the United Film Service have just been completed, involving the expenditure of approximately \$6,000.

Increased volume of business has made necessary the changes undertaken. Not only have economy of space and general improvement of facilities been effected as regards the general offices, but the New York exchange, which occupies part of the eighth floor in the Leavitt Building—the home of the United—has been almost doubled in size.

A rearrangement of the file room, wherein copies of all advertising matter put out are kept on file for purposes of reference, is one of the changes made.

Due to the recent installation of a daily program service and the consequent increase in the staff of the shipping department, the quarters of this department were considerably enlarged.

George B. McGuire, superintendent of films, has been installed in a private office, built to suit his requirements.

The art department has been supplied with special quarters, no small feature of which is the daylight so valuable in prosecuting work of this nature, which streams in through large windows fronting on Forty-sixth street.

General fireproofing, in conformity with the city ordinance, has been observed in all the changes made.

December 27 Set for "Eternal City" Showing

Hall Caine Play, Produced by Famous Players Under Direction of Porter and Ford and Featuring Pauline Frederick, Filmed in Original Locale

THE much-discussed photo spectacle of Hall Caine's master-work, "The Eternal City," produced in Italy and England by the Famous Players Film Company, will be given its premiere presentation, at the Lyceum Theatre, Sunday evening, December 27, by private invitation.

Under the direction of Edwin S. Porter and Hugh Ford, a carefully selected company, headed by Pauline Frederick, was sent abroad to film this master-work in the exact locale in which its stirring action occurs. All the scenes in the Vatican Gardens, in the Castle of St. Angelo, the Coliseum, the famous Roman Forum, the beautiful Villa D'Est in Tivoli, and other historical spots in the Imperial City were reproduced with the consent of the highest ecclesiastical and civic authorities.

All the costumes of the Noble Guard of the Roman Pontiff, of the Swiss and Municipal Guards were made after specimen costumes of these exalted organizations loaned by the highest sanction. It is the first time in the history of motion pictures that these unprecedented liberties have been granted. Messrs. Porter and Ford also

succeeded in securing the services of thousands of the Roman Carabinieri, and have immortalized with absolutely perfect detail every phase of Hall Caine's wonderful story. The production is on an order of sumptuousness that realizes all the possibilities of the play from a scenic, sartorial and accessional standpoint.

VITAGRAPH BENEFIT A HUGE SUCCESS

The Christmas Fund Benefit given by the Vitagraph Company at the Vitagraph theatre, New York City, Wednesday night, December 9, in which the worthy poor of the city of New York will participate on Christmas Day, was one of the most unique entertainments ever given by a motion picture company, and, besides netting \$1,106, was a decided artistic success.

One of the incidents of the evening was the auctioning off of autographed programs, spirited bidding being the rule, while one program profusely autographed brought \$100, which was cheerfully paid by one of the Vitagraph heads.

Looking Ahead With The Producers

Griffith's Production of "The Clansman" Finished

WITH the exception of the re-making of a few scenes for the allegorical ending, the big multiple reel picture, "The Clansman," adapted from the novel by Thomas Dixon, Jr., on which D. W. Griffith, director general of the Reliance and Majestic studios, has spent a greater part of the past six months in filming, has been finished and will be sent to the factory within the next few days.



D. W. GRIFFITH, FRANK E. WOODS AND G. W. BITZER (CAMERAMAN) IN CONSULTATION

This picture is said by the producers to be the most expensive and stupendous ever made in America, requiring as it did more people, scenes and settings necessary to give atmosphere and realism to every one of the ten thousand or more feet which will be used in the finished product.

In making this it is estimated that more than one hundred thousand feet of negative film was exposed and developed, ten thousand and extra people appeared in battle and street scenes, and all the cavalry companies of the California National Guard took part.

Five separate village scenes were built, costing thousands of dollars. These consisted of buildings made of lumber, fitted with doors, windows, in some instances plastered within; yards where the replicas of flower gardens of Southern homes were made, and picket fences, brick sidewalks, and the coal oil street lights of early days added. On one side of the street store buildings were erected, at the end a church. All are duplicates of buildings and scenes of the anti-bellum period.

One of the most expensive sets was that

of the Ford theatre, Washington, D. C., where the assassination of Abraham Lincoln was accomplished by Wilkes Booth. In this Joseph Hannabery impersonated the part of the martyred President, and R. A. Walsh that of Booth. The stage, boxes, parquet, orchestra pit, and balcony were made to appear the same as on the night of April 14, 1865, when Laura Keane played in "Our American Cousin." Of this set less than two hundred feet will be used in the finished product, and the filming required two days of rehearsals for almost 200 people before the camera was used.

Not only in the matter of settings and props was expense added to this picture, but in selection of players for the leading parts. Henry Walthall, known in Los Angeles as the Edwin Booth of the screen, plays the leading part, Benjamin Cameron, with Mae Marsh and Miriam Cooper as his sisters, Florence and Margaret. The role of Austin Stoneman, the great commoner and noted Southerner, was played by Ralph Lewis, and in order that he might impersonate the part correctly, for two months before appearing before the camera, he wore a shoe with a three-inch sole, thus making it possible for him to appear as a cripple. After finishing the part, it required two months for Lewis' strained muscles to resume their normal condition.

Lillian Gish is featured in the leading feminine part of Elsie Stoneman, with Robert Harron and Elmer Clifton as her brothers. Sam de Grasse was Charles Sumner, Donald Crisp General Grant, Toward Gaye General Lee, Spottiswoode Aitken Dr. Cameron, father of Benjamin, and Josepha Crowell, Mrs. Cameron. Jennie Lee played the role of the old mammy, Cyndy.

"SATAN SANDERSON" CAST OFF FOR FLORIDA

B. A. Rolfe's company, headed by Orrin Johnson and Irene Warfield, in the production of "Satan Sanderson," leaves shortly for Jacksonville, Fla., where a number of the interiors will be staged.

The entire company spent three days at Princeton, N. J., last week, and Director Jack Noble induced a number of college boys to aid in the producing of college scenes.

It is a strange coincidence that Orrin Johnson is a graduate of Princeton, and when he arrived at the college was as thoroughly familiar with the surrounding buildings as though he had rehearsed there. After picking locations, Mr. Johnson took several class leaders to the college register and after satisfying them he was a Princetonian, secured the services of several hundred extras without cost to the company.

"GARDEN OF LIES" ALCO NEW YEAR'S RELEASE

The New Year's release of the Alco Film Corporation will be "The Garden of Lies," in which Jane Cowl, the talented dramatic star, makes her first appearance on the screens of the country. "The Garden of Lies" is a photo-dramatization of Justus Miles Forman's story which has had an international circulation. In the legitimate theatres of England it was played by Sir George Alexander, the noted English actor-manager.

Miss Cowl, the All Star Feature Corporation's players supporting her, two directors and Manager Philip Klein went to St. Augustine for the exteriors and some of the interiors. Several splendid southern mansions were leased for a short period. One was wired and equipped and two reels of interiors were made there.

Jane Cowl in "The Garden of Lies" is the regular Alco release for Monday, January 4.

JUSTINA WAYNE A KRITERION STAR

The All Comedy Films, Inc., one of the producing companies releasing on the Kriterion Program, have secured the services of Justina Wayne. She has had a varied career of the legitimate stage playing leading parts in such productions as



JUSTINA WAYNE

"The Prisoner of Zenda," "The Little Gray Lady," "The Easterner," and "The Prince Chap."

Miss Wayne's first appearance is in a two reel drama entitled "Eliza's Fairy Prince." Cranford Kent plays leads opposite Miss Wayne.

PICTURESQUE GLIMPSES OF THE AMERICAN-MUTUAL PRODUCTION, "THE LEGEND BEAUTIFUL"



THE YOUNG COUPLE DEPART

MARGUERITE CLARK IN "THE PRETTY SISTER OF JOSE"

Marguerite Clark, who recently made her first appearance in motion pictures in the Famous Players' production of "Wildflower," succeeded by "The Crucible," is now at the Pacific Coast studios of the Famous Players, appearing in a film adaptation of Frances Hodgson Burnett's beautiful novel and play, "The Pretty Sister of Jose," the former famous starring vehicle of Maude Adams. Miss Clark will play the title role of Jose's sister, little Pepita, the tiny, exquisite Spanish girl of a thousand moods and whims, who has vowed never to lose her heart, but who, when finally conquered by the handsome Sebastino, loves truly and devotedly, ready to give her life for his, ready to die when she thinks him dying, and ready to live again when the saints give her back his life.

"GIRL OF THE GOLDEN WEST"
RELEASE ON JANUARY 13

The first print of "The Girl of the Golden West," the new Lasky-Belasco production, which is positively to be released on January 4 and which will have its first New York presentation at the Strand theatre on January 3, has arrived in New York. The work of making the additional prints for distribution on the Paramount program is already under way.

"The Girl of the Golden West" is in five reels. Much of the production work was done at the new Lasky twenty thousand acre ranch. This is the first picture for the firm in which House Peters has played.

CAST OF "IN THE SHADOW" ANNOUNCED

"In the Shadow," the next picture to be released by the Excelsior Feature Film Company, is the story of two college boys, whose affection for each other leads to the episodes displaying loyalty, nerve and daring, illustrated in the picture. The parts of the college boys are taken by William A. Williams and Gordon DeMaine.

The love story in the picture is centered about a sister of one of the boys, and the sweetheart of the other. This part is ably filled by Octavia Handworth. The rest of the cast consists of Mary Boyd, Francis Pierlot, and several others.



THE APPARITION

ONE ANIMAL SINGLE A WEEK
FROM SELIG

Each Saturday of the week will see the release of a single-reel animal story, by The Selig Polyscope Company, beginning with Saturday, December 19. According to present plans, W. N. Selig states that this day has been decided upon after a conference with many exhibitors. The Selig Polyscope Company proposes to give exhibitors and the public all the big action and stirring situations similar to those of former features, in single-reel pictures. A further announcement on the subject is promised.

THE REUNION
ROLFE TO PRODUCE "THE HIGH ROAD"

B. A. Rolfe, of B. A. Rolfe Photoplays, Inc., is on his way to Hollywood, Cal., where he is to occupy a new studio which is just being equipped. Mr. Rolfe has been busy with plans for this studio, but before he left for the across the continent trip he announced that he has obtained from Harrison Grey Fiske the rights to produce "The High Road," by Edward Sheldon, on the screen.

NEW PLAYS FOR FARNUM

Samuel Goldfish announces that the versatility displayed by Dustin Farnum in his characterization of Cameo Kirby in the photodrama from the play of that same name has led Mr. Lasky and the entire Lasky organization to devote particular attention to the selecting of a series of vehicles for Mr. Farnum.



JANE COWL IN "THE GARDEN OF LIES" (All Star-Alco Feature)

In and Out of Los Angeles Studios

Special to MOTION PICTURE NEWS

Los Angeles, Dec. 21.

IN the making of "Fooling Father," a one-reeler, Allen Curtis passed the century mark in his work with the Universal, this subject being the one hundredth he has made for the Joker brand. In the hundredth, like the first, the lead was played by Max Asher. This picture shows how a miserly father is induced to come through with the cash necessary for the luxuries of his family, and at the same time change his views with regard to a certain young man who is very attentive to his daughter.

The others in the cast besides Mr. Asher were Gale Henry, William Franey, Lillian Peacock and Ralph McComas. Director Curtis has been with the Universal company for one year and seven months, during which time Clarence C. Badger has written half of the scenarios used by him, "Fooling Father" being the fiftieth one he has prepared.

Wilfred Lucas is filming an unusual story written by Bess Meredith, entitled "Life." In this Cleo Madison plays the part of a pure and unsophisticated village maiden who makes a successful uphill battle against the sins of society.

In the end her life is made a happy one, by virtue of her experience teaching how she could protect others and prevent them from the sorrows that befell her. Miss Madison is supported by a very strong cast, including Edward Sloman, Joe King, Margaret House, Laura Oakley, Ray Hanford and Hylda Hollis. The subject will be completed in two reels.

Curtis Directs Laughable Nestor Play

Both Nestor comedy companies were busy last week, Al Curtis directing the making of "Jimmie's Little Kid," in which a son in forms his father—in order to induce the parent to come through with some extra cash—that he is married and the home has been blessed with a child.

When the father arrives Jimmie's friends and butler secure "a" child, while he hunts up a wife. One infant, when unwrapped proves to be of a darker shade than desired, and is the cause of the son being forced to make a clean breast of the whole deal. Jack Dillon is the Jimmie in the picture. Billie Rhodes the sweetheart, and William Rattenbury the father. "Lizzie's Dizzy Career" features Victoria Forde as a country village lass whose "wonderful" voice causes her to try comic opera. Eddie Lyons, as Jed, her sweetheart from the tall grass, protects her from the villainy of Lee Moran, the stage manager, and the couple decide to marry and conduct a grocery store.

Neilan's Last Week at Kalem

The sacrifices of a husband who finds he has wronged his wife play the important part in a two-reel Rex, "Their Island of Happiness," being filmed by Burton King and company, composed of Ray Gallagher, Edna Maison and Beatrice Van.

Sidney Ayres is engaged in filming a western and Canadian woods story, "The Heart of Sampson," in which the trapper revenges the ill treatment accorded his sister by a passing civil engineer. Val Paul plays the part of the engineer, Scott Beal his assistant, Wilbur Higby an old trapper, Doris Pawn the sister and Mr. Ayres the brother and trapper.

Marshal Neilan has made his last comedy at the Kalem Hollywood studio, featuring Lloyd V. Hamilton, Ethel Teare and others, and has taken up work at the Lasky studio, where he will be starred in "The Country Boy." Later Mr. Neilan will go with the Famous Players western company for a permanent engagement. C. E. Ward will continue as director at the Kalem studio and it is understood another director will be added at a later date. It has not been announced who will be placed in

charge as manager in Mr. Neilan's stead.

The first New York Motion Picture Company production, featuring Bessie Barriscale, "The Cup of Life," produced under the direction of Thomas H. Ince and Raymond B. West, is completed. Of the scenes made for this picture, the largest are those of the ball room. The Inceville stage was equipped with several thousand dollars' worth of furniture and more than 100 people took part.

"The Cross of Fire" is a Canadian woods story filmed by a company of Inceville players in the San Bernardino mountains, where the big trees afford excellent Canadian scenes. The plot shows the cause of a French woodsman becoming a devout Christian, after being a blasphemer of faith for years following his unheeded prayers that his wife's life be spared. Harry Edwards is directing the subject and playing the lead part.

Shorty Hamilton, cowboy comedian at the Inceville studio, has been playing the role of a prizefighter in a comedy, "Shorty and the Prizefighter." In this the westerner, while in the city on business, gets in bad because of the attractive eyes of a maid, loses his bank roll, gets into a street fight and is challenged to a bout by a passing champion "pug." During the fight it is discovered by the cowpuncher that his opponent has weights in his gloves, and after these are removed the professional gets his.

Scott "Directs Deadly Spark"

Sidney Scott directed the production of "The Deadly Spark," a Domino, Broncho or Kay Bee drama, in which a renegade son-in-law, in attempting to rob his father-in-law, after mistreating the wife and daughter, is electrocuted when he touches the knob of the safe, as the result of an attachment the owner had placed there. The death permits the completion of a pretty romance that had been begun years before the wife had married.

INCEVILLE, NOW TO BE RECOGNIZED BY UNCLE SAM AS A CITY, AND ITS CREATORS



THOMAS H. INCE

THE ARSENAL

PANORAMA OF INCEVILLE,
SANTA QUEZ CANON

A CORNER OF THE WARDROBE
BUILDING

MACK SENNETT

William Worthington, character lead for the Otis Turner Special Feature Company of the U, is directing the filming of a story by Mr. Turner, while the little big chief is working on scenarios for several big productions and superintending the finishing of "Changed Lives," a three-reel production now in the laboratories.

"Wolves in Society" is the title of the two-reel picture by the Frank Lloyd Rex Company, which, as the name indicates, is a society drama, written by Mr. Lloyd, who plays the leading part. He is supported by Frank Bennett, Marc Robbins and Gretchen Lederer.

Murdock MacQuarrie is playing the part of a bold bad man, in a crook story, "Putting One Over," in which he is successful in making the police and detectives think him innocent by claiming a baby found in his room, a child of his dead wife, whose father is the man he killed. The picture is directed by Charles Giblyn and the other principals of the cast are Charles Hickman, Seymour Hastings and Agnes Vernon.

The Jack Blystone Joker company is making "Some Nightmare," in which a

and Lule Warrenton. The company will remain at Truckee several weeks.

Selig Produces Allegory

Colin Campbell and Selig players have produced "The Vision of the Shepherd," in two reels, which is of an allegorical nature. The scenes for the shepherd with his flock, where he discovers one lamb is missing, were made on a big sheep ranch in a canyon near Chatsworth Park.

Discovering the lamb missing causes



JESSE L. LASKY AND CECIL DE MILLE AT HOLLYWOOD

the shepherd to recall the disappearance of his daughter, and a vision appears in which the Christ points out where the missing girl can be found. This leads to the reunion of the family and the return home of the daughter. The players in the cast were Charles Clary, Wheeler Oakman, Harry Lonsdale, Frank Clark, Eugenie Besserer and Kathlyn Williams.

The battle scenes for the Tiffany Film Company's feature, starring Mrs. Leslie Carter in "The Heart of Maryland," were made at a big ranch east of Los Angeles. For these scenes a village set, including a church 40 x 60 feet, and several handsome southern homes, located at the fictitious city of Colvert, Md., were built and destroyed.

A full company of cavalry under Captain W. M. Gunn, a company of infantry in charge of Major H. B. Light, and a company of artillery, led by Captain R. A. Ford, of the California National Guard, together with more than one hundred other extra people, were used in these scenes.

Oscar Apfel, Edward Abeles and company of Lasky players producing "After Five" have been enjoying a vacation; that is, if you can call being snowbound such. The players went to Squirrel Inn, in Bear, California, week before last and no sooner had they landed and been made comfortable for a good night's rest before starting on the strenuous work, than a blizzard hit that part of the

mountains. When last heard from none of the players had ventured out to see how deep the snow was, but Mr. Apfel was very encouraging with the news that they could secure enough Arctic atmosphere for hundreds of reels of pictures by pointing the lens out the door.

Lasky's "The Country Boy"

Fred Thomson will direct the Lasky production of "The Country Boy," from the play by Edgar Selwyn, which proved a big New York success, and it has been announced that Marshal Neilan, for the past year director general of the Kalem Hollywood studio, will play the leading part, originated by Forrest Winnant.

George Melford is now directing Harry Woodruff in "The Gentleman of Leisure," and Cecil de Mille will, within the next few days, complete "The Warrens of Virginia," many of the scenes of which were made at the Lasky ranch of hundreds of acres in the San Fernando Valley, north of Los Angeles. In the latter production Blanche Sweet is being starred.

The new glass studio has been completed at the Lasky studio, and players and friends initiated this with a dance given in the evening.

Manager Fred Balshofer, of the Sterling Motion Picture Company, does not permit weather conditions to prevent his companies working, as was shown a few mornings ago, when he hurried players out into a rainstorm and made a rainy day picture, featuring Louise Fazenda and Gus Erdman.



HOBART BOSWORTH AND HIS DOG "SKOOKUM"

dream-producing pipe brings to the imagination of the players pictures of an unpleasant nature. Ernest Shields and Eddie Boland are the dreamers and Phil Dunham puts on skirts and plays the part of the wife of the former.

The Henry McRea 101 Bison company are now at Truckee, Cal., making the exteriors for "Ridgeway of Montana," to be a four-reel production from the story by William McLeod Raine. Strife between two powerful mine owners and their battles for possession of each other's properties makes this book one well adapted to filming, and with the excellent locations afforded by the mountain region of Truckee there is every reason to expect this will be an offering of unusual merit. William Clifford will play the part of Ridgeway and Sherman Bainbridge the opposing mine owner. Marie Walcamp will act the part of Mrs. Harley, and the other principals will be Rex de Roselli, Vivian Rice, Olive Golden



BESSIE EYTON

David Kirkland is directing John Brennan, Willie (Walrus) Walbert and others at Dead Man's Island, where a cannibal comedy is being made.

Play of College Life

When Lewis "Bull" Durham, of the Broncho forces, was a student at Georgetown University he was recognized as one of the greatest football players in

(Continued on page 40.)

AMONG THE EXCHANGES

CALIFORNIA EXCHANGE IN NEW HOME

THE California Film Exchange, which distributes Universal films in the San Francisco territory, and which during the past few years has grown to be one of the largest concerns of its kind on the Pacific coast, is now settled in its new home at 121-127 Golden Gate avenue, near Jones street. This exchange now occupies more floor space than any other film exchange in San Francisco, this being well in excess of ten thousand square feet.

An interesting feature of the new establishment is the attention that has been paid to caring for film. Instead of storing film stock on open racks, as is the general rule there, Manager Morris L. Markowitz has had two large concrete vaults constructed, one on each floor, these having a combined capacity of about eight thousand reels.

The offices, display room and booking department on the main floor take up almost as much floor space as the entire establishment occupied in the old Seventh street quarters, and these are fitted up in sumptuous style.

The location chosen for the new home of the California Film Exchange is in the center of a lively film district. In the block in which it is located are the Box Office Attractions company, The Independent Film Exchange, the Union Film and Supply Company, and the Supreme Features Corporation.

"NIGHTINGALE" REACHES HIGH WATER MARK

ETHEL BARRYMORE in "The Nightingale," the first release of the Alco Film Corporation, although now several months old, enjoyed its most prosperous week during seven days beginning December 14, when every print in existence worked the entire week and orders were received for additional prints from several of the territorial offices.

All in all the booking departments of the various Alco Exchanges sent in the most optimistic reports during the week just past, and combined to make it the biggest Alco week since the inception of that company under its present direction.

FIVE NEW ALLIANCE EXCHANGES OPENED

LAST week saw the addition of five new exchanges to the list of Alliance offices, which now total nineteen.

In the West the new offices are located in Spokane, Wash.; Butte, Mont., and in Denver. These exchanges will do business under the name of the Alliance Programme Feature Service.

The South will have two new offices. In Dallas the new exchange will be known as

the Alliance Film Company, of Texas, and will be one of the best equipped film houses in the South. This concern will operate under the management of J. W. Hill, Jr., and will handle the Alliance Programme in Texas, Oklahoma, Louisiana and Arkansas.

The other Southern exchange will be located in Atlanta, Ga., and will be known as the Hybar Film Corporation. The latter concern will have the exclusive rights to the Alliance output in Georgia, Alabama, North and South Carolina and Florida.

Arthur S. Hyman, formerly general representative of the World Film Corporation in the South, and P. T. Barber, late advertising manager of the Atlanta Constitution, are the men behind the Hybar organization.

LOS ANGELES EXCHANGE MEN ORGANIZE BOARD OF TRADE

THE organization of the Los Angeles film exchange men, to be known as the Film Exchange Board of Trade, has been fully organized, officers elected, and arrangements made for affiliation of this body with the one of San Francisco.

By this affiliation it will not be necessary for the local organization to apply for a charter from the state, and while the entire organization will be known as the San Francisco Film Exchange Board of Trade, the members of this city will have a local organization.

The manager, whose name has not been announced, will take up his duties the first of the coming year, and will at that time open offices, which will become the clearing house for troubles of the exhibitors and exchange men as well. The officers will not be announced until later.

A few of the exhibitors have been heard to complain that this organization will eventually cause an increase in price and other regulations of the trade unfavorable to the theatre owner. This, according to exchange men who are members, is a mistake, and the sole purpose of the organization is for the betterment of the business and regulations only that will be of benefit to the trade generally.

MACK MANAGER OF PICTURE PLAYHOUSE IN SYRACUSE

WILLIAM A. V. MACK, formerly manager of the Peerless Feature Film Company, has accepted a similar position with the Picture Playhouse Company, with offices at 201 Vinney Building, Syracuse, N. Y.

Mr. Mack has had several years' experience in the film business, is well known among the exhibitors throughout New York State and already reports excellent business from his new location.

UNIVERSAL BUYS THREE WESTERN EXCHANGES

WITH the announcement of David Bershon, who has been with the California Film Exchange, Inc., with branches at San Francisco, Los Angeles and Phoenix, Arizona, that he is to be succeeded on December 28 by J. W. Allen, as manager of the Los Angeles exchange, it became known that the three exchanges had recently been sold to the Universal Film Manufacturing Company. The three exchanges were established by M. L. Markowitz and Mr. Bershon, and the former will remain as manager of the San Francisco studio. A. B. Knox, who has been manager of the Phoenix branch, for the past six months, will remain in charge there.

Mr. Allen, who is to become manager of the Los Angeles exchange comes here from the Warner's Feature Exchange at San Francisco, where he has acted in capacity of district manager. Mr. Bershon has not made a statement as to his intentions for the future, but by friends it is understood that he will be identified with the motion picture industry. He has been in charge of the Los Angeles exchange since March and has won the confidence and esteem of the exhibitors of Southern California and been wonderfully successful in increasing the rental business of Universal releases.

WARNER SAN FRANCISCO EXCHANGE MOVES

THE J. L. Warner Film Company, of which Jack L. Warner, formerly manager of the San Francisco branch of Warner's Features, is the head, has taken offices on the sixth floor of the Pacific Building, Fourth and Market streets, San Francisco, and will be ready for business as soon as the large stock of film already arranged for is received.

The Pacific Building was selected as headquarters as there are already four large exchanges located there, as well as several concerns selling state rights. Mr. Warner recently returned from a trip to New York, on which he was accompanied by his wife, a bride of a few weeks.

BOX OFFICE MANAGER IS HARD AT WORK

HARRY F. CAMPBELL, manager of the New England office of the Box Office Attractions, is cutting a lively pace in film circles of Boston. He assumed the managership only a short time ago, but already he has got some of the biggest houses in New England on his string, including Poli's Plaza, Worcester; the Colonial, Brockton, which opens January 11; the Park, Bangor, Me., which opens December 28 with "The Walls of Jericho," and the Mystic theatre, Malden. He is also book-

ing the new Modern theatre in Boston and Keith's theatre, Providence. In addition to these he has booked no less than eight other houses this week which will use the Box Office three-reelers. On Monday Manager Campbell installed a new booking department, which is in charge of Thomas Jennings, formerly with the General Film Company.

DRESSLER COMEDY GETS PLENTY OF BOOKINGS

"TILLIE'S Punctured Romance," in which Marie Dressler, Charles Chaplin and Mabel Normand play the leading roles and which was released last Monday by the Alco Film Corporation, has provoked the greatest bookings in the history of that organization.

Four prints of this production are booked up so far ahead in New York State alone, that two extra prints are being secured by the New York State alone, that two extra prints are being secured by the New York Alco Exchange to take care of the incidental bookings.

CUSICK WITH UNIVERSAL IN DETROIT

GEORGE CUSICK, for the past few months manager of the Jefferson theatre, Fairview, a suburb of Detroit, has resigned and accepted a position as traveling representative for the Detroit-Universal Film Company. Mr. Cusick left December 3 with two films, "Trey o' Hearts" and "The Master Key," and will make a complete tour of the Dominion of Canada, covering that section of the continent from coast to coast. Previous to his going to the Jefferson, he was with the National theatre.

ISAACS OF BOX OFFICE VISITS FRISCO BRANCH

M. A. ISAACS, a representative of the Box Office Attractions Company, was a visitor in San Francisco last week, inspecting the local office of this company, which is conducted under the able management of Wm. Citron, a well known Coast exchange man. He found conditions in a very satisfactory shape, with this branch enjoying a volume of business in excess of anticipations.

NEW MANAGER FOR KLEINE'S MINNEAPOLIS OFFICE

C. M. THALL has been appointed manager of the Kleine branch office at Minneapolis. He succeeds Harry Rowe, resigned. Mr. Thall will be remembered as one of the Kleine representatives traveling out of the main office. He counts a host of friends among exhibitors throughout the country, having been actively engaged in the film business for the past three years.

MACK TO MANAGE BOSTON ECLECTIC

A. N. WEBSTER, formerly of the Syracuse Eclectic office and road man for the General Film Company, has severed his connections with the Boston Eclectic Company.

He will be succeeded as manager by Joseph Mack, formerly manager of the Hub theatre.

Jesse L. Lasky Returns to California Studios

While in New York He Held Numerous Conferences with Belasco and Goes to Pacific Coast to Supervise New Productions of the Company

AFTER a stay of less than a month in New York City, Jesse L. Lasky will start for California and will remain there for some time to supervise the various new productions which are being made at the Lasky studios and on the new Lasky ranch in the Santa Juacinta Mountains.

The recent vast enlargement of the Lasky manufacturing facilities in the West has made Mr. Lasky himself anxious to supervise the undertakings of the next few weeks, and particularly to be present during preparations of the forthcoming Lasky-Belasco releases, notably the "Warrens of Virginia" in which Blanche Sweet makes her debut, and "The Woman," by William C. De Mille.

During his brief stay in New York Mr. Lasky has held a series of conferences with David Belasco and their decisions as to the next productions in the Lasky-Belasco series will be announced shortly. Mr. Lasky goes back to the coast thoroughly acquainted with Mr. Belasco's views of picture producing in every particular, and the work of preparing the Belasco releases will now be pushed forward with all possible speed.

Mr. Lasky is himself a Californian and welcomes the business necessity of spending the winter on the Pacific coast. Within a week of his own departure, his entire family will follow to remain there throughout the winter season.

Selig Monthly House Organ Pleases Exhibitors

"The Monthly Release Herald" for January Contains Program Fully Illustrated with a Synopsis of Each Picture

EXHIBITORS all over America have just received their copies of the latest number of the "Selig Monthly Release Herald," issued by the publicity department of the Selig Polyscope Company, from the executive offices in Chicago.

The entire program for the month of January is illustrated and a synopsis of each picture is given in this issue. The illustrations are clear and distinct, and the synopses are well written, so that the exhibitor can readily form his opinion of each picture.

This edition bears the date of January, and is number one of volume two. Since the inauguration of the monthly magazine by the Selig Publicity Department, a great many letters have been written by exhibitors complimenting the Selig concern on the excellence and desirability of the publications for the use of exhibitors.

There are three pages of editorial notes and general information in connection with future releases by the Selig Polyscope Company. Every item will prove of interest to exhibitors.

ZENITH, DULUTH, SEES BUSINESS REVIVAL IN NORTHWEST

THE Zenith Feature Film Company, of Duluth, which handles the Alliance Program in Minneapolis, Wisconsin and North and South Dakota, in a recent communication states that the film people are experiencing a revival of business in his territory.

J. F. Cubberly, who was one of the pioneer picture men in the Northwest, is managing head of the Duluth concern and under his generalship the Zenith has become a big factor in that section of the country. Mr. Cubberly's success has been due to his system of keeping in intimate touch with his clients, studying the needs of each and giving his advice and counsel to all who ask it.

DICKERSON HAS "RUNAWAY JUNE" IN DETROIT

DOUGLAS DICKERSON, formerly manager of the World Film Corporation office in Detroit, is handling the new serial "Runaway June" for the Detroit branch of the Mutual Film Corporation. Mr. Dickerson has been connected with that office for the past eight weeks.

IN KANSAS CITY EXCHANGES

THE Alco Film Company have temporarily closed their Kansas City office, merging with the St. Louis branch. The office of Warner's Features in

Gloyd Building that was under J. C. Woolf's charge has now secured the services of Richard Broderick as manager.

KALAMAZOO CHAIN OF THEATERS SIGNS FOR PARAMOUNT

THE Kalamazoo Amusement Co., of Kalamazoo, Mich., of which Mr. Goddie Rosenbaum is president, has entered into an arrangement with the Casino Feature Film Co. whereby the Paramount Service will in the future predominate at their chain of theatres, comprising the Lyric, Colonial, Elite and Orpheum. The deal was consummated when Mr. Rosenbaum was in Detroit on Monday, November 16.

J. D. JAMESON NEW MANAGER IN SEATTLE FOR KLEINE

J. D. JAMESON, connected with the Kleine Pittsburgh office as traveling representative, has been transferred to Kleine's branch at Seattle, Wash. He becomes manager of the Seattle office, succeeding O. R. Henkel, resigned.

KLEINE OPENS NEW PHILADELPHIA OFFICE

GEORGE KLEINE'S rapidly growing business has made it necessary to open a Philadelphia office. John J. Rotchford has been appointed branch manager in that city with offices at 1309 Vine street.

Motion Picture News

HAS THE QUALITY CIRCULATION OF THE TRADE

MOVING PICTURE NEWS EXHIBITORS' TIMES

Published Every Week by

EXHIBITORS' TIMES, Inc.

New York Offices..... 220 West 42nd Street
Chicago Offices..... 223 West Jackson Boulevard
Los Angeles Offices..... 427 South Figueroa Street

WILLIAM A. JOHNSTON..... *President*
HENRY F. SEWALL..... *Vice-President*
E. KENDALL GILLETT..... *Secretary*
H. ASHTON WYCKOFF..... *Treasurer*
WENTWORTH TUCKER..... *Ass't Treasurer*

WILLIAM A. JOHNSTON..... *Editor*
LESLEY MASON..... *Managing Editor*
WILLIAM RESSMAN ANDREWS..... *News Editor*
H. ASHTON WYCKOFF..... *Business Manager*
R. M. VANDIVERT..... *Advertising Manager*
THEODORE S. MEAD..... *Chicago Manager*
J. C. JESSEN..... *Los Angeles Manager*

This publication is owned and published by Exhibitors' Times, incorporated under the laws of the State of New York. The offices and principal place of business are at 220 West 42nd Street, New York City. The address of the officers is the office of the publication.

Entered as Second-Class matter at the New York Post-Office.

Subscription \$2.00 per year, postpaid in the United States, Mexico, Hawaii, Porto Rico and the Philippine Islands. Canada, \$3.00; Foreign \$4.00 per year.

ADVERTISING RATES ON APPLICATION.

Copy for next issue must reach us by Tuesday, 5 p. m.



Cuts and copy are received subject to the approval of the publishers and advertisements are inserted absolutely without condition expressed or implied as to what appears in the text portion of the paper.

Vol. X January 2, 1915 No. 26

The Exhibitors League on the Eve of 1915

THE Motion Picture Exhibitors League of America is approaching the New Year with signs of steady, healthy growth multiplying on every hand.

Not for many weeks has there been such good reason for indulging the brightest possible hopes for the future of the organization as is furnished by the meeting of the New Hampshire state exhibitors at Concord, Friday, December 18.

* * *

THE New Hampshire league is the youngest of the state organizations.

Yet the initial assemblage of its members revealed an attendance of nearly fifty per cent. of the state exhibitors, and the probability is strong that every theatre manager in the Granite State will rally to the support of the young association before it is much older.

Not only did the new president, Charles H. Bean, of Franklin, N. H., labor for weeks to accomplish the gratifying results of December 18, but President Horstman, of the neighboring Massachusetts League, put his shoulder to the wheel and did everything in his power to assist the formation of the new branch. As proof of his interest in the movement he attended the first convention in person with several of his associates, and addressed the exhibitors on the merits of organized co-operation.

THE same alertness to the present importance of organization is being manifested in many widely separated sections of the country.

Slowly but surely the business policies and business methods of President Pearce and his associates of the Executive Committee have spread to every one of the outlying state organizations until now the serious, intelligent and harmonious pursuit of a sound and common-sense plan of action is visible wherever and whenever a state league convenes for a deliberation on trade conditions.

* * *

IN Michigan, for example, the state league has already scented the perils of the free coupon plan, which is beginning to ravage the business in that state as it already has in Utah.

President Jeup and his fellow members are determined to make a vigorous fight against the system, which, be it said to the credit of the organization, is almost, if not quite, wholly practised by exhibitors outside the league.

In Michigan, New Hampshire and Massachusetts the state leagues have settled down to a strenuous resistance of the various kinds of legislation which are being prepared for them in political circles.

The Pennsylvania exhibitors, bowed as they have been for months under the oppression of a state censorship, have rallied throughout the state and are arming themselves to "have it out" with the Legislature when that body convenes in Harrisburg the latter part of next month.

* * *

SIMILARLY, in Minnesota—though the exhibitors' organization there is not identified with the National League—the same energy and determination is being shown in the face of the Sunday closing law which has been drafted by the Northwestern Society for the Prevention of Vice.

Not the least insulting provision in the bill is classification of motion picture theatres with dance halls and pool-rooms—an attitude of mind that may have been justified six or eight years ago, but which implies ignorant and intolerant narrow-mindedness today when the best element in the community is cordially and frankly supporting the photo-playhouse.

In Baltimore, President Pearce's home city, problems that affect the business of exhibitors in that city are being vigorously dealt with at the meetings of the local body, and to good effect. It was the Baltimore exhibitors, be it remembered, with aid of the exchanges, that prevented the exhibitor who would have reduced his admission price to two cents, when accompanied by a three-cent coupon, from carrying his inexcusable and demoralizing scheme into execution.

* * *

THERE is a businesslike spirit manifesting itself in everyone of these local and state bodies.

The exhibitor members are applying to the league the same methods they were wont to use in their own successful businesses. Circus methods are being gradually dislodged. Commercial methods are taking their place. Eccentricity is giving way to efficiency.

Exhibitors here and there are beginning to treat each other as human beings with a right to live and prosper instead of as thieves, robbers and cut-throats. Co-operation is at last getting a following as a profitable policy.

* * *

FOR all this the Motion Picture Exhibitors League of America and its Executive Board and officers have reason to be deeply grateful. Their work has not been wasted.

A brighter year has not dawned on the league since its foundation than the one which is at hand.

In and Out of Los Angeles Studios

(Continued from page 36.)

the collegiate circles of the South. That, perhaps, is the reason why he has contributed such a realistic bit of acting in "The Scrub," a fascinating story of college life and a gridiron battle, that will be released January 8. Durham plays Coach Sloane, a hardened master of stripling players, and plays it with a "punch" in every action.

An entire day was spent by Inceville's electricians in the construction of an apparatus for use in "The Deadly Spark," a Kay-Bee ready for release January 1. The punch of the story is delivered by the scene which depicts the electrocution of a man who attempts to rob the safe of his father-in-law.

The elder man conceives the idea of defeating the intruder, of whose plans he has been informed by the wife, by administering to him an electric shock. To obtain the desired effect, wires were strung from the Inceville power house to the stage and there adjusted to the safe. A shower of sparks is seen as the crook topples over dead.

An invasion of the Mojave Desert, which began in an automobile, but which terminated on the backs of plodding donkeys, was made recently by a company of players from the forces of the New York Motion Picture Corporation to obtain a number of important scenes for "A Midas of the Desert," a gripping two-part production soon to be released by the Kay-Bee company, January 8.

The story teams with an interest in the life of an old miser who, disliked by his townspeople, goes into the desert in search of more gold.

Go to Nevada for Desert Scene

The title role is played by Walter Edwards, who, instead of being satisfied—as are a number of other companies—with the desert stretch near Playa del Rey, journeyed all the way to Nevada for his realism. Mr. Edwards brought back with him a collection of toads and other reptiles which infest the desert, and they are now on exhibition at the Inceville studios.

"Jack's Pals" is the title of a one-reel animal picture written by C. W. Murphy, trainer at the Selig zoo, who is playing the leading part. The direction is in charge of F. J. Grandon. It is a story of a zoo trainer, who, because of crookedness of his superior, loses his position at a municipal zoo. He succeeds in getting a place on the fire department in the vicinity and—well, he saves his pets from being burned when the zoo is destroyed, and for his work is made superintendent of the new zoo. It is a very pleasing play.

The scenario for the film version of "Ill-Starred Babbie," the anthracite coal region story by W. H. Whalon, was prepared last week by Will H. Ritchie, of the Balboa company, at Long Beach, and production will be commenced as soon as Jackie Saunders, who is now spending a vacation at Philadelphia, returns. The subject will be of four reels and features Miss Saunders.

Hal Roach, producer for the Rolin Film Company and Los Angeles representative for Sawyer, is on his way to New York, where he will spend several weeks.

The Nash Motion Picture Company has begun production of a two-reel drama, which is to be released on the Kriterion program. The direction is in charge of Thomas H. Nash, and for the present the company will work at the studio on Court street.

The Santa Barbara Dramatic Company, making Kriterion program film, in charge of Director Bob Daly, has completed four subjects, "The Arm of the Law," "Jealousy," "Call of the Sea," "Common Clay" and "Pearls of Caracas," in which Fritza Brunette, for several years leading woman with the Imp company, and Edward Alexander, formerly of Powers and Rex companies, play leads. John Prescott, Jack Dillon and Florine Garland have the other important parts of the casts.

Bert Angeles has been directing comedies of the Percy series, with a company composed of Mary Ruby, Sidney de Gray and Harry Fisher, and now has four ready. The titles of these are "And Percy Got Married," "And Percy Made Good," "And Percy Put One Over," and "And Percy Becomes a Medico."

In addition to managing the affairs of the Santa Barbara company, Mr. Kennedy is acting as western representative for the Mica Film Corporation, making all arrangements for production, supervising the selection of scenarios for all, and looking after the many details connected with the making of and marketing of a new program.

The Navajo Film company players, under the direction of Charles K. French, have completed three two-reel western dramas, and were recently working on the fourth, "The Squatter," in which a cast composed of Lucile Young, William Parsons and Helen K. French play the leading parts. The other subjects completed are "Nevada," "Though Thy Sins Be as Scarlet" and "Joe's Partner, Bill," all of a western nature, highly melodramatic, but not of a blood and thunder variety.

These subjects will be released through the Kriterion program of the Mica company.

U. S. Will Open Laboratories Soon

General Manager George E. Duke, of the United States Feature Film Company, of Oroville, California, spent a part of the week here, making preparations for the opening of the company's laboratories and in the purchase of equipment for their studio for winter use which will be completed within the next few weeks.

The laboratories are to be fitted with the products of the Los Angeles Motion Picture Company, makers of the Angelus cameras, printers, splicers, and other necessities, including tanks, drums, etc., and all will be ready for use by the first of the year, the sale being made by Carl E. Fr. Sternlov. The winter studio is of concrete and steel with glass walls and roof, and has a stage 75 x 90 feet. The prop room, wardrobe, scene dock and laboratories will occupy a new building measuring 100 x 150 feet.

The U. S. Company has now completed its first subject, "The Folly of a Life of Crime," featuring George Sontag, one of the leaders of the famous band of criminals known throughout the West as the Evans-Sontag gang. This consists of six reels and will be released for state rights in the near future.

THE "PERCY" SERIES OF THE SANTA BARBARA COMPANY (Kriterion Service), AND ITS MAKERS



SIDNEY DE GRAY
(Comedy Lead)

MARY RUBY AND HARRY FISHER IN
"PERCY GOT MARRIED"

MARY RUBY

SIDNEY DE GRAY AND MARY RUBY
IN "PERCY MADE GOOD"

BERT ANGELES
(Director)

Flashes From Chicago Film Circles

Special to MOTION PICTURE NEWS

Chicago, Dec. 22

THE preliminary arrangements were made by the executive committee of The Reel Fellows Club for a monster Costume Ball à la Rex, which will be housed in Chicago's largest auditorium for such affairs. The initial plans as drawn up by the reigning officers will establish this event as the first of its kind ever held in the big middle west metropolis. The outlook for its success is very bright.

Many scenic artists associated with the various motion picture studios in and about Chicago will be employed to make the hall a picturesque enclosure. Many of the noted artists with their famous character portraits will have their booths so constructed as to represent some familiar scene in a big production in which they have taken part. The entire affair will be so conducted that it will be made thoroughly representative of the art of motography.

All this is working toward the establishing of a permanent quarters for the Reel Fellows Club, which has had an astounding growth since its inception some half dozen months ago. The membership represents every branch of the industry. While it would be possible to already go ahead with club rooms, it is felt that they would not be the kind or spacious enough that would be desired within six months.

Because of the wide representation within its ranks it is felt that this Costume Ball will establish a record breaking event in the Windy City.

Special Publicity Committee at Work

Each member will make special efforts in the line he is interested to pass the good word and create enthusiasm that is bound to bring about. A special publicity committee of newspaper men has been appointed that will work toward getting news notes in the various trade papers and the daily papers in and about Chicago. Committees have been appointed consisting of men that are experienced in the various duties that have been entrusted to them by the club.

The executive committee consists of Warren A. Patrick, chairman, R. R. Nehls, Charles Nixon, Omer F. Doud, L. A. Boening, W. R. Rothacker and C. J. VerHalen. The arrangement committee is headed by Walter Early, Neal Caward, Frank Hough, R. C. Traverse and Rapley Holmes. Charles Andress is chairman of the publicity and program committee, and is assisted by Walter Hildreth, Fred Wagner, E. O. Blackburn and C. J. VerHalen. The entertainment committee consists of W. R. Rothacker, chairman, N. Sawyer, O. F. Spahr, O. F. Doud and E. J. Hickey. The refreshment committee consists of Tom Quill, J. W. Brickhouse and George A. Berg.

At the last regular meeting of the Reel

Fellows Club of Chicago, which will be held at the Hotel Sherman, in the Italian room, on Wednesday evening, December 16, the gathering was addressed by Mr. Blair of the Eastman Company. His subject was "Raw Stock."

At each meeting the club will be addressed by some representative person in the motion picture business on the branch of the business he represents.

In the future the headquarters of the Reel Fellows Club will be suite 505 Ashland Block, all the officers of the organization can be reached at this address.

New Selig War Film Out

In these days of war talk and an unprecedented activity on the part of motion picture manufacturers, who endeavor to present the news features of the world in films, an unusual production has been released through the General Film Co., by the Selig Polyscope Company. It is entitled, "A History of the World's Greatest War Told in Five Reels of Motion Pictures."

Although coming from the same source as the Hearst-Selig News Pictorial this five-reel special production is not identified with the twice-a-week Hearst-Selig News Pictorial Service. It is announced as being produced by the Hearst newspapers in conjunction with the Selig Polyscope Company.

The five reels are of particular interest and show actual battle scenes with shot and shell, and all the carnage of battle. These pictures were taken by Selig camera men assisted by Hearst newspaper correspondents who worked together to obtain them. These intrepid news-picture gatherers photographed the scenes from dangerous positions, along the battle lines in Belgium, East Prussia and other places. Many of the scenes were photographs in the fighting trenches with the Allies and with the Germans.

Clark Street Theatre Sold

While there have been other releases of pictures said to have been taken on European battle fields, the Selig Publicity Department declares that this one is the only authentic and genuine picture actually taken on the European battlefields while the fighting was going on in the war theatres.

MOST INTERESTING OF ALL

F. & H. AMUSEMENT COMPANY,
Orpheum Theatre, Gary, Ind.
Editor Motion Picture News,
New York City.

Dear Sir: In answer to yours of the 5th, beg to advise that I find the "News" the most interesting of them all.

Very truly yours,
V. U. YOUNG.

Another large film theatre has just changed hands. John H. Ferris, who formerly was active in the theatre business but has been out of it for three years, has purchased from the Clark Amusement Company the leasehold on the Clark theatre at 4533 North Clark street, between Wilson and Sunnyside avenues, for a bonus reported to have been about \$10,000.

The theatre contains 1,100 seats and is under lease for \$6,500 per annum, with nine years to run. The buyer plans to expend about \$20,000 in remodeling the house and to put in a pipe organ and ten-piece orchestra. Hume & Co. and George W. Walker closed the deal.

Selig Films Second Beach Novel

Lanier Bartlett, scenario editor for the Colin Campbell-Selig feature company, departed last week for the Panama Canal Zone, as the "advance agent" for the company which will leave the first week in January for a trip of three months in tropical America, where the second Rex Beach novel, "The Ne'er Do Well," will be filmed.

Mr. Bartlett, who prepared the working script for this, as well as practically all big features produced by Mr. Campbell and his players, will select locations and have everything in readiness for work when the company arrives.

In addition, while in the Zone, Mr. Bartlett will write a number of two and three-reel scenarios suitable for locations in that territory. The party, besides Mr. and Mrs. Campbell, will be composed of Charles Clary, Wheeler Oakman, Al Green, Frank Clark, Sidney Smith, Harry Geistad, R. H. Kelly, Will Carson, Helen Castleton and Kathlyn Williams.

PAUL PANZER ON VAUDEVILLE TOUR

Paul Panzer, who as Raymond Owen meets death by drowning in the last episode of "The Perils of Pauline," has decided to take a few weeks' vacation by doing work of another sort.

Bill Casey, nephew of Pat Casey, saw him in a vaudeville act over in Brooklyn several months ago and decided that on the conclusion of "The Perils of Pauline" he wanted to book the "popular villain" for an extended vaudeville tour. So "Oom Paul" starts in at the Auditorium in Malden, Mass., on December 14 for a week's engagement and after New Year's will play engagements in various cities for fifteen weeks straight at an attractive salary.

On the expiration of his vaudeville contract he will return to Pathe to perpetrate other deeds of villainy on the screen.

Kennedy Makes Careful Selections for Kriterion

His Experience Qualifies Him for Picking Out Suitable Films for Clientele of the Company—Reorganizes Santa Barbara

FRANCHISES covering the manufacture of films for the Kriterion program have been issued with great care and on an entirely original plane. The instigators have not selected their manufacturers indiscriminately. They have entrusted to A. M. Kennedy the entire supervision covering the selection of manufacturers and the granting of contracts to the manufacturers in question.

A. M. Kennedy was particularly well adapted to the requirements as he had for the last seven years been connected in an executive capacity as general manager and managing director of some of the largest and most successful film manufacturers in the world today.

The names particularly connected with Mr. Kennedy's reputation in the business are the Essanay Film Manufacturing Company, the American Film Manufacturing Company and as the organizer of approximately 60 per cent. of the producing companies of the Universal Film Manufacturing Company. Too great stress cannot be laid on the fact that the Mica Film Corporation has the service of such a man as Mr. Kennedy.

In the selection of the manufacturers for the Kriterion program it was continually borne in mind that while money is essential to the successful manufacture of pictures, brains and talent are the predominating requisites to worth-while films. Therefore the franchises which Mr. Kennedy tendered were given invariably to experienced and proven motion picture directors.

In every instance these directors or managing directors have complete control of the organization for which they are responsible and the films that will be released under their particular brand.

One of the producing companies of the Kriterion, namely, the Santa Barbara Motion Picture Company, located in Santa Barbara, Cal., is under the general management of A. M. Kennedy. He has entirely reorganized this company to take care of the releases tendered it by the Kriterion people. This company is considered to be one of the best equipped motion picture companies in California, where it is well known that 70 per cent. or more of the films produced in America are made. It is safe to predict that good productions will come from Mr. Kennedy and all of his sources.

"Under the Paint" Offered at the Vitagraph

Dramatic Story of the Theatre, Written by Charles L. Gaskill, Presented in Conformity with Policy of Weekly Change of Bill

THE Vitagraph Theatre, New York City, has introduced a spoken one act drama as a novelty in conjunction with the feature and special pictures, vocal and instrumental music which now comprises the regular program.

Sidney Drew, supported by a company of Vitagraph players in "What the Moon Saw," furnished the audible feature of an exceptional bill that opened the week beginning Sunday, December 13. "What the Moon Saw" was written by S. Rankin Drew, and is a powerful drama that works up to a tremendous climax, breathtaking in its intensity. While thrillingly dramatic there are moments when laughter relieves the tension, adding the necessary variety to make the act one of unusual merit. Mr. Drew and his associate players appeared

every night and at the Saturday matinees only.

The picture part of the program, which was shown twice daily, included as its principle feature "Underneath the Paint," a three-part dramatic story of the theatre, written and produced by Charles L. Gaskill, and presented by Helen Gardner, assisted by Anders Randolph, Gladden James, Rose Tapley, Albert Roccardi and little Audrey Berry.

In conformity with the new policy of the Vitagraph Theatre, which includes the presentation of new pictures every week, "A Question of Clothes" and "An Egyptian Mummy," two single reel comedies, and "Out of the Past," a two-part feature drama of unusual appeal, were shown in addition to the big feature pictures.

American Cast "Rough It" on Wild Island

Company Spends Two Weeks on Santa Cruz Island and Films Situations Amid Semi-Tropical Settings While Players Live by Primitive Efforts

AFTER two weeks on Santa Cruz Island the feature company from the American-Mutual studios at Santa Barbara has returned to headquarters. The island is wild and mountainous. Its lakes and waterfalls and abundant semi-tropical vegetation combine to make wonderful scenic settings, and in a feature soon to be announced in the Mutual program is shown the landing of shipwrecked voyagers and their primitive efforts to take care of themselves on the uncharted island which Santa Cruz for motion picture purposes is presumed to be.

While these pictures were being taken

the company had to live primitively, for there are no accommodations on Santa Cruz Island. Necessary provisions had to be shipped over. For meat the company had to depend on the men's success in shooting wild pigs and hooking fish. Getting to places was difficult, too, and often dangerous. In ascending a mountain, for instance, Margarita Fischer had to be tied between Harry Pollard and his assistant. Coming home poor old Pete, the Pollards' pet bulldog, was awful, awful sick, and one of the cowboys fell overboard. On the whole the company was very glad to get back to civilization.

"U. S. A. DAY" INSIGNIA CHOSEN



The committee on general arrangements for the impending nation-wide campaign to establish a Made-in-the-U. S. A. Day has selected its official insignia.

The design chosen is one of forty-nine submitted by the cleverest commercial artists of the city and was selected principally on account of the predominance of the geographical element.

It reproduces in black and white the map of the United States, which in accordance with congressional action, inspired by Theodore Roosevelt during his term as President of the United States, is now officially known as America, which word appears in bold white lettering across the surface, the map, in solid black, being background. The motto, "Boost for U. S. A. Day," appears on the design, divided so as to partly surmount and partly form the base of it.

The legend, "Made in America," also appears so worded as to be incorporated in the geographical tout ensemble.

MOTION PICTURE NEWS reproduces above the design just chosen.

HAL AUGUST CAST TO DO "STUNTS"

Hal August, probably the youngest film player who is a man grown and yet has played grown-up leads, has a part to his liking in the production which Edwin August is putting on for the Kinetophote. He will have ample opportunity to practice the



HAL AUGUST

"stunts" which have made him popular in the past with directors of other companies.

The role of the inquisitive and active young reporter has been assigned to Mr. August, and what stunts he will be put through are for the future to chronicle.

Mr. August is not yet twenty years of age and has been in pictures for three years, principally with his brother, Edwin.

IMPOSING SCENES FROM "THE SIGN OF THE CROSS," FAMOUS PLAYERS CHRISTMAS RELEASE



THE CHRISTIAN MARTYRS

"LET THE LIONS COME!"

THE FEAST OF BACCHUS

"THE SIGN OF THE CROSS"

(Famous Players-Paramount—Four Reels)

REVIEWED BY H. S. FULD

THE producers of this film version of Wilson Barrett's sublime and immortal drama, "The Sign of the Cross," have certainly surpassed themselves in this wonderful conception. In the depiction of Roman life, no expense seems to have been spared to make these scenes as realistic as possible.

William Farnum, in his impersonation of Marcus Superbus, certainly looks the part, and needless to say he acts the part. Rosina Henley, in her role Mercia, the Christian maid, has the sympathy and holds the interest of the observer as perhaps no other character could.

Of the story itself, it is so well known, having been novelized and dramatized on the legitimate stage, that we will not go into it here. Suffice to say, that in this film version the essential points in the story are all brought forward, and the result is a production of intense dramatic power enhanced by good photography, an excellent cast, and lavishly decorated and gorgeous interiors.

In depicting the arena and banquet scenes and Emperor Nero's audience chamber, the strictest attention to detail is noticed. Especially so, as it befits and brings one to the realization of the luxury-loving Roman patricians.

The action runs along smoothly. The story is gripping and holds one in suspense by the masterly acting of the principals in their different characterizations. The finale is a really beautiful setting of a cross on a hill, which the slowly rising sun brings to prominence.

Special credit should be given the producers, in that there is no lack of subtitles; not that they are profuse, but what is better, there are none lacking.

"THE LAST CHAPTER"

(Favorite-Alliance—Five Parts)

REVIEWED BY J. C. JESSEN

SILHOUETTE, moonlight, camp fire and unusually clear mountain scenes in "The Last Chapter," an adaptation from the Richard Harding Davis novel of adventure, "The Unfinished Story," mark this release of the Favorite Players-Alliance program as one of unusual merit, and one for which the location man and photographer, Homer Cook, are justly entitled to praise.

Such was the verdict of the members of the producing company, their friends, and a number of exhibitors who were present at the dress rehearsal run, given at Clune's Broadway theatre, Los Angeles, one evening last week, after the regular performances, which end at eleven-thirty. It was an enthusiastic party that left the theatre at one o'clock in the morning, and many expressed the opinion that this will prove the greatest box office receipt getter this company has so far produced.

The Davis story is well adapted for screen portrayal, and the character of Gordon, the explorer, is one in which Carlyle Blackwell is most at home. The role gives him opportunity to display his versatility, in the drawing room, but most of all as a lover of nature, who likes the open, adventure and excitement of a charge.

His dashing manner attracted the attention of Alice Edgeton, played by Ruth Hartman, and he won her from the many suitors

of her social set, prior to his departure with an exploring party for South Africa. Following a mutiny of the aids of the party, Gordon is left to die, and by his assistant carrying away papers, and later being killed by savages, rangers believe Gordon is killed and notify his sweetheart and friends in his native land.

Instead, Gordon accomplishes the purpose of the exploring party and is then found by rangers. Upon his return he finds his sweetheart, believing him dead, engaged to another, so he returns to Africa to lend his aid in improving the natives' health conditions.

Mr. Davis saw fit to conclude the story in this manner, but to the film version, "The Last Chapter," has been added by Richard Willis, who prepared the scenario. In this Alice Edgeton recalls her love for the adventurer, and seeing the emptiness of the life



ON THE WAY TO LAKE TCHAD

she would lead as the wife of a prominent politician, follows Gordon to Africa.

There, following a skirmish between members of her party, government officers and natives, Gordon rescues her from savages intent upon taking her to their village, a prisoner. Both rejoice at this unexpected meeting, and in the end she becomes his queen, he her king, and their lives are sacrificed for the betterment of society. Good comedy is injected in the feature by the character of Reggie, played by John Sheehan, and other important parts are taken by William Brunton, Harry Kernan and Ollie Kirkby.

BUILDING WITH 100 DRESSING ROOMS FOR MUTUAL

A HUGE building containing one hundred dressing rooms has been erected on the grounds of the Griffith-Mutual studios in Los Angeles, together with another two-story structure for the stage carpenters. The latter building is fully equipped with work benches, and all the modern requirements for building and remodeling stage settings.

"THE IDLER"

(Box Office—Five Reels)

REVIEWED BY PETER MILNE

THIS picture would be more appreciated and better understood if in the first two reels more subtitles were employed to explain various matters that do not become clear until near the end, or perhaps more carefully written titles, more explanatory in nature, would fill the gap. At any rate, the picture as it stood when viewed was slightly confusing, and it seems as if the fault might easily be corrected by attention to the titles.

After the first few misunderstandings have been rectified, along approximately in the middle of the picture, when the plot has narrowed down to the point where only a small number of characters are concerned, the story becomes understandable.

Charles Richman makes his second screen appearance in one of the principal roles. He plays the part of Cross, who might be termed the heavy of the play, although he is a heavy who gains a great deal of sympathy as the story progresses. Cross has secretly married a chorus girl on a bet, when the picture opens, and finally when he refuses to grant her impossible requests for money, she publicly announces the union. This greatly perturbs the mind of the girl whom Cross loves, so he and his friend, John, depart to America and become prospectors.

Across the water, John accidentally kills the brother of an American and hastily departs for home, the Western town being rather too warm for him. At home he becomes a Sir and marries the woman whom Cross loved. Later Simeon Strong, intent upon avenging his brother's death, visits England with Cross. But he falls in love with the sister of the girl whom his intended victim married. After several tense scenes he becomes pacified, and accepts Sir John's word that the murder was accidental.

After this, Cross attempts to persuade Sir John's wife to come with him, but after the two have had quite a struggle in a room, she causes him to realize his shameful conduct, and the picture closes with Cross meditating his past, and perhaps his future.

Catherine Countiss is seen as Sir John's wife, and in the latter part of the picture is well suited to the part, several years having elapsed after the first two reels, in which she seems slightly old for the role. Claire Whitney appears as her sister, Walter Hitchcock is Sir John, and Stuart Holmes carries the part of Strong.



LADY HARDING LEARNS CROSS IS A WIDOWER

Whether it is merely in the print shown or in the negative, we do not know, but at any rate, the photography as witnessed seems rather poor, badly lighted in some scenes. The fire scene in which Cross's wife meets her death, starts with amazing rapidity, but no doubt audiences would grow impatient while waiting for a fire to spread, if left to itself.

Lloyd B. Carleton directed the picture, and if the fault mentioned in regard to the first parts were eliminated, he may be credited with a very acceptable piece of work.

"SPRINGTIME"

(Life-Photo-Alco—Five Reels)

REVIEWED BY CLIFFORD H. PANGBURN

BASED on Booth Tarkington's successful novel and play of the same name, "Springtime," offers an unusually attractive story, which has been prepared for the screen in a style worthy of the subject.

Perhaps the most striking feature of the picture is the constant succession of beautiful exteriors. The action of the story takes place in New Orleans at the time of Andrew Jackson's victory over the British during the siege which marked the close of the War of 1812. Accordingly it was necessary to find a location for making the pictures which would meet rather exacting requirements. By going to New Orleans and St. Augustine, Florida, exactly the right places were found for obtaining the atmosphere of the old South.



THE FATHER PROVES HARD-HEARTED

The house, which is used as the family home of the De Valettes, is a splendid specimen of Southern colonial architecture. It has the typical colonnade around three sides, and the second floor porch, or "gallery," as it was called, on which the members of the family spent much of the time. This house is set in the midst of beautiful grounds which are used to great advantage, as are other attractive scenes. The general result is, as may be imagined, decidedly attractive.

Another notable fact is that the producers have succeeded in obtaining the impression of the period to a remarkable degree. Anachronisms have been avoided and the proper details supplied so carefully that the spectator feels as if actually viewing events of a hundred years ago.

Florence Nash, who is featured in the role of Madeline De Valette, handles the part with the skill which one would expect from so well known a player. She appears to equal advantage in the easiest scenes and in the difficult ones after grief has affected the heroine's mind. Gilbert Steele, the hero, is well played by Bert Gardner, although owing to the construction of the story the part is almost a minor one. William H. Tooker is seen as Val De Valette, the father of Madeline. Adele Rey is effective as L'Acadienne, and the rest of the cast does meritorious work.

Madeline is betrothed to her father's cousin when she is a small child. As the story opens he is coming to meet her. She dislikes the thought of marrying him, while he is scarcely less opposed to the match. Gilbert Steele, the son of an enemy of Madeline's father, comes to her home to attempt a business transaction with her father.

Madeline and Gilbert fall in love on sight, and she follows him when he leaves the house. He has enlisted in a company which is going out to meet the attacking British and Madeline even seeks to go with him. This she cannot do, of course, but as she wanders about all night her father thinks she has dishonored the Valette name and turns her away.

At the same time she hears a false report that Gilbert is dead. The combined shock temporarily unbalances her mind, but when Gilbert returns he soon cures her, and her father, realizing his folly, blesses the young couple. His cousin leaves, happy to avoid the match, as he is in love with another girl.

"THE THREE OF US"

(Rolfe-Alco—Five Reels)

REVIEWED BY CLIFFORD H. PANGBURN

WITH this film another star practically unknown on the screen, but a great favorite on the stage, makes a welcome re-appearance. Mabel Taliaferro is an actress of rare charm, and she succeeds most admirably in putting her personality into this picture. Miss Taliaferro is seen in the role of Rhy MacChesney, the girl who places her sweetheart's success above her own reputation. Rhy is one of the most attractive characters created by Rachel Crothers, the author of the original stage version of "The Three of Us."

The photographic and scenic effects in the picture are excellent. True, the country does not resemble the mining region of Colorado very closely, but considering the limitations imposed by taking the picture in the East, John W. Noble, the director, has accomplished wonders in exterior effects.

One impressive scene is that depicting the fight between Steve and Beresford. This is one of the most realistic fights which have



STEVE AND RHY REUNITED

been seen on the screen in some time, and is bound to have any audience on the edge of the seats.

The story of "The Three of Us" has to do with a mine of that name which had been left to Rhy MacChesney and her two brothers, Clem and Sonny, by their father. The father had always had great faith in the mine, and had begged that it be worked carefully. Clem, a young chap, with ambitions for more excitement than is offered in the mining camp, wants to abandon the mine and go to New York, where he imagines he can win success.

His sister tries to dissuade him, but when Beresford, a mining expert looking for something good, offers him \$500 for a tip, the boy gives him one, little realizing that he is endangering his sister's happiness and his own future by doing so. The tip is that Steve Towney has struck pay ore on his mine next to "The Three of Us," and that his option expires at noon the next day.

It happens that Steve is Rhy's sweetheart, and delays his trip to buy in his mine in order to see her at a party being given that night. Meantime he leaves his option at her home, and it is stolen by Beresford.

Rhy accidentally discovers the theft and the guilty party, and going to Beresford's house at night gets the paper back, but is misunderstood by Steve, who sees her entering the place. When Beresford attempts familiarities, Steve comes in and thrashes him.

Rhy then starts for Gold City to take up Steve's option herself and save him from Beresford. Of course all ends happily. The mine is saved, and it is discovered that the vein in it goes through "The Three of Us" mine. Steve learns how he has misjudged Rhy, and they are completely reconciled. Altogether a pleasing story well acted.

WHISTON GOES TO BOX OFFICE

WILLIAM E. WHISTON, who for the past year has represented the George Kleine Attractions in New York state, has resigned in order to accept a position with the Box Office Attractions. Mr. Whiston will work out of the Syracuse office.

"THE MASTER KEY"

(Universal Special—Sixth Episode)

REVIEWED BY PETER MILNE

HERETOFORE we were inclined to criticize "The Master Key," because, unlike most serials, it contains few events that might be classed with the sensational thrillers. Like many other people, we were inclined to think that a recurrent story could not exist without a punch in every episode. Up to date "The Master Key" has consistently proved that hair-raising events are not indispensable to maintain the interest in a serial photoplay.

We don't mean to say that this story has nothing in it to elevate itself from the ordinary in the way of thrillers. It has, but it is not crammed full of them; those that do appear are excellent, but tense interest is maintained in "The Master Key" whether they appear or not.

The great interest which many are evidencing for this story is undoubtedly due to the excellent manner in which the plot is developed by John Fleming Wilson, the author, and Robert Leonard, the director. Just as a written story in which there are only two principal forces, good and bad, forever working against each other, even though the end is no more apparent after reading six chapters than it is after the first, is immensely interesting, so is "The Master Key."

To come back to this separate episode, the only fault we have to find with it is that a stone wall shakes. Although it is hardly noticeable, it should have been avoided, as such things seem to belong back in the days when motion pictures were in their infancy. However, this detracts nothing from the interest which is sure to be manifested in the story.

The situations that are brought out in these two reels while Dore is in search of Ruth, aided by a number of other men, are many and strong, so that in the finale when he at last rescues her from a Chinaman all will be inclined to breathe a sigh of relief.

The awe inspiring revolving brick chamber in which Ruth



THE POLICE ARE UNABLE TO FIND RUTH

is imprisoned, by the Chinese agents of Wilkerson, is used with excellent effects in a number of scenes. This, with its accompaniments, such as sliding panels and secret doors, are enough, with the exciting story laid among them, to maintain whole-hearted interest from the beginning to the end, besides causing us to wait impatiently for the next episode.

ELIZABETH FORBES JOINS THANHOUSER

ELIZABETH FORBES, late of the Henry Miller-Doris Keane "Romance" and other companies successful in New York, has been added to Thanhouser's stardom. Miss Forbes' first appearance will be in "Under False Colors," a two reel release featuring Florence La Badie. Like many screen stars, Miss Forbes' first chance to see herself as others see her was accidental. When on a visit to the Thanhouser studio she laughingly consented to play a part. Her work so favorably impressed Directors Eugene Moore and Frederic Sullivan that she was engaged to play a role in "Zudora."

"PERILS OF PAULINE"

(Pathe-Eclectic—Last Episode)

REVIEWED BY WILLIAM RESSMAN ANDREWS

DAINTY, daring, delightful Pauline leaves the public in this the twentieth and last episode of one of the most successful serials ever brought out.

The heroine's troubles are over, and of course she marries the deserving young man whose unsleeping vigilance saved her from death on so many occasions.

The people who have followed the fortunes of the pair week in and week out with ever recurring interest in each set of adventures will learn with regret of the departure of Paul and Harry for that mysterious land of rest and quiet reserved by considerate authors for all characters in fiction and drama who have faithfully entertained an appreciative public.



ABOARD THE YACHT TOGETHER

This last vehicle of their exploits surpasses the former releases in novel situations and thrilling moments. The scenario writer, Charles Goddard, shows not only the same resource of invention demonstrated in previous episodes but in many respects goes beyond himself.

With a sense of the dramatic fitness of things he has reserved the most thrilling situations for the finale. In themselves they might not seem strikingly unusual, but by clever assemblage of his material the whole two reels constitute a picture of compelling originality.

A secret—not *the* secret, of course, for it requires more than one thing to make a successful film play—which has a great deal to do with the effectiveness of any production is its simplicity of plot.

A plot incapable of development except by a numerous cast fails in an essential point. On the other hand, a story—like that of "The Perils of Pauline"—needing only a few characters sustains interest at every stage. All chances of confusion in the minds of the spectators are eliminated. If "The Exploits of Elaine," the serial of the company to follow "Pauline," is constructed on the same broad, general lines, the possibilities of its making an instant hit are already assured.

In this last episode Owen, discouraged by the failure of his efforts to make away with Pauline through the aid of confederates, determines to attempt her life by his own hands. While he and the girl and her cousin Harry are on the Marvin yacht, pleasure bent, the vivacious girl asks Harry to teach her how to run a motor boat.

Owen thinks he sees in this desire a chance to dispose of the girl for all time. He bores a hole in the bottom of the small craft, plugging it up with cotton waste. The villain expects the boat to leak slowly and take the girl beneath the waves beyond the reach of timely aid. The next morning, accompanied by her faithful dog—a canine actor of considerable ability, whose intelligent understanding of his mistress' commands later on results in her rescue from a watery grave—Pauline sets out in the motor boat. When miles from the yacht it springs a leak, and she barely reaches a waterlogged canal boat before the motor boat sinks. But she escapes one danger only to run into a greater

peril. The hulk has been anchored in this position to serve as a target, and the shells from a battleship crash through a canvas bullseye above the head of the terror stricken girl.

Fortunately, the realization of her position does not paralyze her faculties, and she uses the dog to send a note to the battleship commander, who of course, instantly stops the firing of the guns, and sends a tender to the rescue.

"OFFICER 666"

(Kleine—Five Reels)

REVIEWED BY PETER MILNE

FOR his first American release George Kleine has chosen an auspicious subject, one that has been long heralded, and one that bids so fair to be a huge success. It has the advantage of all pictures that were once stage successes—everyone has heard of it. But the picture needs no previous reputation to make it go. It stands firmly on its own merits, which are manifold.

Augustin MacHugh was the author of the play, and, by special arrangement with George Cohan and Sam Harris, George Kleine received the rights for the picture version of the famous stage farce. Frank Powell, the director of the production, has procured such decisively excellent results in screening the story that "Officer 666" can almost be accounted the largest and brightest feather in his already well decorated cap.

In a large measure the humorous qualities of the offering depended on the ability of the cast. Individual and incidental actions, recorded by many of the able cast, are responsible for many outbursts of appreciative laughter, whereas if the principals were poorly versed in their art, the plot itself would hardly be comical enough to carry the interest through the entire five reels.

We are inclined to offer all the more praise to both director and actors, because of the fact that there is no great variety of scene. A greater part of the actions transpires in four or five rooms of one house, but variety of settings seems in this play a minor point. Those that appear are well built and appropriate.



OFFICER 666 IS DISCOVERED AGAIN

In regard to photography, the film is clear and distinct, but not too bright throughout.

The leading part, Travers Gladwin, as interpreted by Howard Estabrook, is made exceptionally humorous. Harold Howard in the role of Barnes, the friend of Gladwin, is thoroughly efficient; his eccentric actions, while experiencing all the troubles of his friend, who is engaged in ridding his house of a gentleman burglar, will be responsible for many laughs.

Sidney Seaward is an excellent gentleman burglar, whose specialty is collecting priceless paintings from other people's houses. The name part of the picture is played by Dan Moyles, who makes a truly good-natured, thick-headed Irish denizen of the law. Makoto Iuokuchi as Gladwin's Japanese butler is as funny as the rest.

Lois Burnett, Della Connor and Ada Nevil are the only feminine members of the cast; the former two as the girls who finally find their mates in the persons of Gladwin and Barnes are very good. Miss Nevil is the aunt and is equally humorous.

"TWO WOMEN"

(Broadway Star Features-Vitagraph—Three Reels)

REVIEWED BY PETER MILNE

WITH only four players of any importance, Ralph Ince has produced a three-reel picture which is not tiring in the least. Its attractiveness rests mainly with the excellent interpretations rendered by the four principals, and again due to the fact that there are not a great number in the cast.

Interest is awakened from the very first scene and is well held until the very last. There are no tiring counterplots with other characters to confuse the spectator. The story is plain, straightforward, concise and gripping.

Its main attraction, other than those mentioned, is its striking contrasts. On one side is the life of the deceitful society woman, outlined with decisive, convincing action; on the other is the young, innocent, wild girl of the mountains.

Due to his wife's thoughtless deceit, Emerson, a business man, divorces her and then seeks seclusion in the mountains. Here he meets Anita, tells her his past life and remains with her, refusing to return to his wife, even when she pleads with him herself.

Earle Williams gives a most convincing portrayal of Emerson, a man rather untutored to deceit, who at first trusts wholly to the sincerity of his wife. Julia Swayne Gordon has the unhappy part of the wife, and plays it as the occasion demands. She is cold at first, regretful later, and finally beseechingly pathetic when imploring her husband to return to her. Harry Northrup as Lawler, Emerson's employer, who afterwards marries the latter's wife, is a real, unsympathetic heavy. Anita Stewart looks sweet and pretty as usual, and plays the part of the girl of the woodlands to perfection.



JOHN TELLS ANITA OF HIS PAST LIFE

In the mere outline of the story it sounds uninterestingly simple, but as has already been said, it is absorbing all the way. Each of the four parts is really a character study and every part will grip.

The scenes, too, offer the same contrast that the characters do, the wild uncultivated mountain land and the staid city homes and offices. The photography is good in all the scenes.

"Two Women" will be a success; its unconventionality, its charm and its pathos, and again the excellent acting and direction unite to make it a picture the like of which is not often seen.

"THE BEAUTIFUL UNKNOWN"

(Victor-Universal—Three Reels)

REVIEWED BY PETER MILNE

SOME mythical European kingdom back in the days when men were bedecked in lace and silks is the place and time in which the action of this picture transpires. It is obvious that the director, William J. Bauman, took great pains to procure the correct atmosphere for the picture by seeing that no touch of modernism should creep into any scene. The sets and the actions of the characters are strictly in keeping with the time and place, so that when one sees the picture, if he will but forget his immediate surroundings, he will be transported back a few hundred years.

If the whole atmosphere of the production is not enough to cause one to forget his environment, the introduction of "The Beautiful Unknown" most certainly will. "The Unknown" is played by Yona Landowska, a dancer, and her most pleasing performance comes when she dances to win the heart of the gay and flippant prince, which she accomplishes with great success.

Although she is not the actual embodiment of perfect grace, her rendition of some weird dance of her own will not fail to please. In fact, it may particularly delight that part of the audience which is comprised of "tired business men," and it is doubtful if it will strike any as offensive.



THE PRINCE FAILS TO APPEAR

This dancing act being the major part of the picture, there is little else to relate, only that the story is a very good one, interesting in its entirety. And even though the period of this production has been reproduced in pictures before, it is not overworked, and seems to smack off a decided freshness, which will cause it to be all the more welcome.

Matt Moore plays the gay King Ferdinand, who falls captive to the charms of the princess. Walter Miller and Charles Moran are his boon companions, while Irene Wallace and Betty Emerson are the sisters of the "Beautiful Unknown."

"THE SECRET OF THE MOUNTAIN"

(Pathe—Four Reels)

REVIEWED BY CLIFFORD H. PANGBURN

PRODUCED at the European studios of the Pathe company, this picture is filled with the usual fine scenic effects and settings of exteriors which are found in such pictures. The story is one which is rather weak in plot, but is strong in human interest and is acted with much skill.

Among the many effective views introduced are some showing the carnival parade in an Italian city, and some mountain districts, where a picnic is held and where the hero has the fall which is believed by his friends to have ended his life. In these latter pictures there are some fine cloud effects. A number of striking water scenes are also introduced at several points.

A wealthy farmer sends his son to the city to be educated. The boy gives way to temptations and is soon spending money at a fast rate, much of it going to a girl named Helene. His father is so wrapped up in what he supposes his son's happiness that he keeps on supplying him with money until he is bankrupt.

Then the son has a streak of remorse, which is accentuated when the girl leaves him on account of lack of funds. He decides to go abroad and seek his fortune. A fall in the mountains is believed to have killed him, and he says nothing, hoping that his father can collect his life insurance. This proves to be impossible, and the result is that the old man becomes a beggar after his estate is sold at auction.

He meets the former mistress of his son, and she is so overcome by remorse that she makes a home for him.

Finally the son comes home from South Africa a wealthy man, and after much trouble locates the girl and his father. Realizing the fine character of the girl, the young fellow marries her, and everyone is happy.

"THE EXPLOITS OF ELAINE"

(Pathe—Episode One—Two Reels)

REVIEWED BY CLIFFORD H. PANGBURN

ADVANCE information on this new series indicated that it would be a rare combination of good effects. The first episode, known under the title of "The Clutching Hand," in every way comes up to expectations. If the remaining installments are up to the standard set by this one, the serial will be a notable one.

As previously announced, the scenario has been written by Arthur B. Reeve, author of the famous "Craig Kennedy" stories,



CRAIG KENNEDY RECOGNIZES HIS FINGERPRINTS

which have appeared in the "Cosmopolitan Magazine." Mr. Reeve's stories will appear simultaneously in newspapers throughout the country, and in film version at the various theatres.

The cast is a most excellent one. In the role of Craig Kennedy, Arnold Daly, one of the most prominent legitimate players in the country, does very effective work. The role is that of a dignified, forceful and calm scientist, who, under his cool exterior, is always alert and fully aware of everything which is going on around him, down to the smallest details.

It is therefore a difficult part, but Mr. Daly has handled it with entire success in this installment. Pearl White's role as the heroine called for considerably more emotional acting than anything which she has done recently, but the part was well played. William Riley Hatch as her father, the life insurance president, has a brief but important career in this episode.

"The Clutching Hand" is a mysterious criminal. The insurance president has learned something of him through one of his victims, a one-legged beggar, but has received many warnings from the criminal to stop his investigations. He finally puts the papers bearing on the case into a secret compartment in his house and fills the envelope which had held them with blank paper.

This is almost his last act, as he is killed shortly afterwards by an ingenious device of the "Clutching Hand." An electric wire is attached to a hot-air pipe leading to his room. As he steps on the brass register in the floor, he falls dead. The criminal, who is completely disguised with a handkerchief mask, then makes a hole in the safe with a special preparation and take out the envelope, marked so that he supposes it to contain the papers-incriminating himself.

Craig Kennedy is told by a reporter that the insurance man knows who the "clutching hand" is, and replies that in that case the man is dead. Going to his house they find that this is the truth, as the murderer has just finished his work. Kennedy then starts to work on the case, and is astounded to discover that the finger marks which the criminal made purposely conspicuous are apparently his own.

THANHOUSER INSURES MARGUERITE SNOW FOR \$150,000

MMARGUERITE SNOW has been insured by the Thanhouser Film Corporation for \$150,000 as a guaranty against accident. Miss Snow in company with other members

of the Thanhouser "Zudora" company had a narrow escape from death last week.

Miss Snow, Elizabeth Forbes, Helen Badgley, James Cruze and Director Frederic Sullivan were driving along a country road on Long Island, returning from the taking of a scene, when the machine skidded, the rear wheels sliding over a stone bridge, balancing the car in the air. It was only the quick work of the men in the party and the coolness of the women that saved the situation.

When the party reached the studio Director Sullivan reported the near accident and it was then determined to insure Miss Snow's life, and a policy was subsequently taken out for \$150,000.

"ARE THEY BORN OR MADE?"

(Humanology-Warner—Four Parts)

REVIEWED BY WILLIAM RESSMAN ANDREWS

THIS picture, the scenario by Jack Rose, whose knowledge of the under-world qualifies him for the task he set himself, gives a vivid representation of life among criminals. The film does not deal wholly with the sordid aspects of life, however. In the story has been woven the refining effects of a good woman on a nature which has been submerged in the undercurrents of a great city through sheer force of circumstances.

Rose has shown that many criminals and derelicts are more sinned against than sinning. At heart they are not bad; they are the victims of environment; no matter how much they fight against evil associations, fate seems to have marked them for the downward path.

A number of well-photographed and cleverly-constructed scenes are used to illustrate this theme. The action never lags, and the spectator is swept along engrossed in the development of the story. An excellent cast was picked by Director McGill, and his handling of crowds in the "mob" scenes deserves particular mention.

The author and producer have selected a wide variety of episodes and localities as settings for unfolding the plot. There are delightful pastoral scenes that seem to breathe the very fragrance of country peace and innocence, and at the other extreme one views the revolting degradation of sinister and ill-smelling slums in a big city.



THE FIGHT BETWEEN THE RIVAL GANGS

A gang leader while in the country falls in love with the daughter of a farmer and marries her against her parent's opposition. Neither father nor daughter suspect his real occupation until at election time the leader, wounded in a gang fight, becomes the subject of a front-page newspaper story. His wife recognizes his picture and decides to leave him for her father's home.

The gangster, however, arouses her sympathies in relating the story of his early life, by dwelling on the insurmountable difficulties which prevented him from rising to a plane of respectability. She feels that he was less to blame than the bad influences he was unable to fight against, and on his promise to go to the country and begin life anew, amid uncontaminating surroundings, forgives the past. He goes with her to the farm where the couple live in happiness.

INTERESTING FILM REVIEWS

PRODUCTIONS FROM ALL PROGRAMS

GENERAL FILM PROGRAM

"The Mayor's Secretary." (Kalem. Two reels. Mon., Dec. 21.)—This story is one in which a girl hired by the Women's League to watch a political boss becomes involved in some desperate attempts to work a graft scheme. On two occasions she proves herself to be of heroic strain, and finally saves the life of the honest mayor, and becomes his bride. Very melodramatic, but interesting.

"The Winning Whiskers." (Kalem. Tues., Dec. 22.)—A burlesque which in some senses an extravaganza as it shows the heroine weeping until she floods the room. The principal part of the film is taken up with a dime novel which a cook is reading. By way of passing it might be said that the story which is burlesque is not so very different from some which have been seen as serious productions on the screen.

"The Fatal Opal." (Kalem. Two reels. Wed., Dec. 23.)—One of the many films which Kalem has released which have to do with mysterious crimes and remarkable discoveries of the real criminals. In this case a young man is accused of killing his uncle. There is a good circumstantial case against him, and things look bad until his young bride happens to discover a remarkable clue which leads to the finding of the real murderer.

"The Reformation of Ham." (Kalem. Fri., Dec. 25.)—A burlesque comedy of the "Ham" series. It has to do with a fight and general rough-house which takes place between some American sailors and a gang of Chinese pirates in a water front town. In the course of the story Ham is broken of the liquor habit.

"The Escape on the Limited." (Kalem. Sat., Dec. 26.)—The seventh of the series featuring Helen Holmes in "The Hazards of Helen." The girl telegraph operator is informed over the wire that a stranger who has appeared in the district is a defaulting bank cashier. She is told to capture him, but he ties her up and gets away by jumping onto the outgoing limited train. Helen with a detective chases the train on a gasoline car, and seeing that he will be captured the crook jumps off and is killed. In addition to Miss Holmes the regular cast is seen.

"The Black Sheep." (Kalem. Two reels. Mon., Dec. 28.)—A story which suggests "Damaged Goods" as it deals with a somewhat similar topic. A doctor is secretly in love with a girl next door. His wild brother comes home from the West where he has made good and reformed, but his reform has come too late. The doctor tells him that he must never marry. This is overheard by the mother of the girl next door, who has been infatuated with the younger brother. The mother tells her the situation and the diseased man is spurned. Later the girl marries the clean living young doctor.

"The House of Silence." (Biograph. Mon., Dec. 28.)—A husband becomes so jealous of his wife's former suitor that he will never speak to her. Prenatal influence results in her child being born dumb. The husband then turns her out of his home, and she enters a state institution for the care of the dumb. Later there is a reconciliation through the child who is treated by the very man who was so misjudged by him. Very melodramatic. Augusta Anderson appears as the unfortunate mother, and Alfred Paget as her unreasonable husband.

"Mr. Daly's Wedding Day." (Edison. Mon., Dec. 28.)—A comedy detective story in which a smuggler and counterfeiter is run to earth after having his own way for some time. The chief cause of his undoing is found in Connors, a taxi driver who has been paid with a bad five-dollar bill. Augustus Phillips is featured as the chauffeur, and plays the part with extreme realism.

"The Product." (Vitagraph. Mon., Dec. 28.)—A drama in which a whisky manufacturer becomes the victim of his own liquor, until his wife takes desperate measures, which include burning down the distillery. Estelle Mardo and Thomas R. Mills are seen as the distiller's wife and a reformed victim of whisky.

"The Plot." (Vitagraph. Two reels. Tues., Dec. 29.)—Hypnotism and nihilism go hand in hand in this melodrama. An American reporter discovers that Russian revolutionists are planning to assassinate the ambassador from their country to the United States. As the reporter is in love with the ambassador's daughter he tries to prevent the act. He is hypnotized by one of the conspirators and almost forced to kill the ambassador himself, but is saved at the last moment by the daughter. All ends happily, and the girl's love overcomes the hypnotic spell. Estelle Mardo is seen as the ambassador's daughter, and Robert Gaillard as her father.

"The Crimson Moth." (Biograph. Two reels. Tues., Dec. 29.)—A melodrama in which an unscrupulous man attempts to make use of a curse supposed to rest on his cousin's family. He breaks off his engagement with a nurse when he learns that his cousin is ill and likely to die and leave him a great estate. The cousin gets well and marries the very nurse the other man had jilted. This makes him doubly furious, and learning from an old book that "whenever the Crimson Moth appears a Huntington is doomed," he gets a crimson moth and lets it appear at what he believes to be exactly the right time. It happens that he is the Huntington doomed as he falls from the window through which he has introduced the moth and is killed. Huntington and his wife are played by Jack Drumier and Louise Hale.

"Love, Oil and Grease." (Kalem. Tues., Dec. 29.)—One of the Ham series of slapstick comedies. Ham and Bud become automobile salesmen, and the result can better be imagined than described. Their battle with oil and bricks is a remarkable affair.

"A Cowboy Pastime." (Lubin. Tues., Dec. 29.)—An amusing comedy which is in the nature of a burlesque of western pictures. It depicts the riotous adventures of Heine Pretzel and Luke Mutt in the peaceful hamlet of Hamville. Bad Ike also takes part in the gun-fighting and general trouble.

"The Derelict." (Kalem. Two reels. Wed., Dec. 30.)—A man is in love with his partner's wife, but she repulses him indignantly. Her husband suffers from headaches, and his partner gives him headache powders containing habit forming drugs. His plan succeeds in that the man becomes a drug fiend and a human derelict. His wife, however, will have nothing to do with the other man. Finally the criminal realizes the terrible sorrow he has inflicted on the woman he loves and takes steps which lead to a restoration of the husband to his family and a cure of the drug habit.

"The Intriguers." (Lubin. Two reels. Wed., Dec. 30.)—An involved melodrama concerning the adventures of Viola Vincent and Winthrop Hagen, two crooks who make a living by stealing while passing as society persons. Viola's specialty is blackmail, while her partner is an expert at stealing jewels. Viola nearly wrecks the happiness of a young couple in the course of one of her expeditions, but is finally arrested with her partner, and the lovers reunited.

"Forcing Dad's Consent." (Vitagraph. Wed., Dec. 30.)—The old story of a kiss from rouged lips being described to a credulous wife as the mark of a blow. A hypocritical father refuses to allow his daughter to have anything to do with a young man until the youth discovers the old man at a fast cabaret, and disguised as a dancer flirts with him. Constance Talmadge and Billy Quick are seen as the youthful lovers, while the father is played by Lee Beugs.

"Love Will Out." (Vitagraph. Thurs., Dec. 31.)—Artists and their ways are favorite themes with picture producers, and this is another film story of the studios. An artist with high ideals but no common sense almost becomes a thief, but changes his mind just in time. Then he meets with a certain amount of success, and marries a girl who is a thoroughly practical commercial artist, and gives promise of being able to support him. Margaret Gibson is seen as the girl artist, while her lover is played by Carleton Weatherby.

"Fate and Fugitive." (Lubin. Two reels. Thurs., Dec. 31.)—The familiar story of a man

who is mistaken for a criminal because he is the exact double of the burglar. There are a number of rather exciting incidents, and in the end the hero is barely saved from committing suicide when he thinks that there is no way to avoid punishment for a murder with which he has absolutely nothing to do.

"Two Stray Souls." (Biograph. Thurs., Dec. 31.)—An ex-convict who is living "straight," is married to a girl who has been through the same experience. Both fear the other will learn of it. When blackmail is demanded of the husband as the price of silence regarding his past his wife learns of it and confesses her own history. Happiness is theirs once more.

"Auntie's Portrait." (Vitagraph. Fri., Jan. 1.)—An egotistical but wealthy and elderly aunt of a young couple writes that she is sending them a present. It proves to be a very poor picture of herself. The young folks put it in the attic, when to their dismay the aunt suddenly calls. The husband tries to hang the picture while his wife keeps the aunt in conversation, but fails. He then goes out and comes back saying that he is just bringing the picture from an art store where he has had it framed. There are some other complications concerning the cook, but all turns out well, and the aunt is appeased.

"Getting Father's Goat." (Kalem. Fri., Jan. 1.)—An entertaining comedy which is well acted and staged. A judge's daughter is allowed by her father to take a place as a reporter. She discovers a gambling house in which her father often plays poker. After the raid which she brings about she finds an I. O. U. signed by her father. When her sweetheart, who was caught in the same raid, is about to be sent to jail by the hypocritical judge his daughter shows him her find and he changes his mind suddenly.

"The Efficiency Squad." (Biograph. Fri., Jan. 1.)—A split reel with "Diogenes Weekly, No. 4-11-44." An amusing comedy of the adventures of a police chief and some gunmen of truly desperate appearance, but less terrible actions.

"Diogenes Weekly, No. 4-11-44." (Biograph. Fri., Jan. 1.)—An entertaining burlesque of the news films. On the same reel with "The Efficiency Squad."

"A Clean Slate." (Lubin. Fri., Jan. 1.)—The regular triangle, except that the wife is pitied by the other woman who really cares nothing for the erring husband. He is sent back to his wife in a very repentant state, and they start again. Lillie Leslie appears as Azamora, the dancer with whom the husband is infatuated, while Justina Huff is his wife. The husband himself is William Cahill.

"All for the Boy." (Biograph. Sat., Jan. 2.)—Foolish infatuation has resulted in a broker's son becoming involved with a woman of the vampire sort. His father tries to buy her off, and failing takes her to a country house where he has her locked up until after the son's marriage at which she had vowed to create a scene. She interests a financier who breaks the broker, but he is satisfied with the thought that he has saved his son from life-long unhappiness. Jack Mulhall and Marie Newton are seen as the son and his sweetheart, while Vivian Prescott and Jack Drumier appear as the vampire and the boy's father.

"In the Latin Quarter." (Vitagraph. Two reels. Sat., Jan. 2.)—A melodrama concerning the trials and jealousies of two artists who are competing for the same prize, and one of whom is painting from a model loved by his rival. In the end the troubles are all overcome, but not until the model has nearly given her life to save the painting for which she had posed.

"The Girl Telegrapher's Peril." (Kalem. Sat., Jan. 2.)—Another of the series featuring Helen Holmes in the "Hazards of Helen." There are a number of fine railroad views, but Helen's principal feat is the familiar one of running onto a trestle in front of an express to save a child who had wandered out over the river. She is also responsible for an engineer running down a man on a track tricycle as she takes his attention from his work by talking to him while riding in the cab.

"He Gave Him a Million." (Lubin. Sat., Jan. 2.)—A split reel comedy which depends for its humor on the antics of an insane man. On the same reel with "What He Forgot."

"What He Forgot." (Lubin. Sat., Jan. 2.)—Bill played as an extra in a motion picture and was much pleased because he had to kiss the leading lady. He forgot that his wife was likely to see the film. When she did so there was trouble.

"Uncle Crusty." (Edison. Sat., Jan. 2.)—Produced in co-operation with the National Kindergarten Association, this picture is aimed at the sort of person who seeks to make children unhappy by refusing to allow them to indulge in their natural play instinct. It shows the experiences of a man who nearly has a fit every time he hears a child laugh.

UNIVERSAL PROGRAM

"Hunting in Crazy Land." (Powers. Split reel. Fri., Dec. 25.)—This comedy which is on the same reel with "The Japanese Silk Industry" belongs to the animated cartoon class and is very funny. A hunter, his dog and a bear are the only three figures that appear. Their antics, such as swallowing bullets and climbing up walls, will call for only the heartiest laughter.

"The Japanese Silk Industry." (Powers. Split reel. Fri., Dec. 25.)—An interesting educational taken under the auspices of Homer Croy while on his recent trip. Native dances and a few views in Japan are shown toward the end of the reel. This is shown on the same reel with "Hunting in Crazy Land."

"For the Defense." (Eclair. Sun., Dec. 27.)—This reel opens with a man on trial for murder, the scene fades out when the girl witness for the defendant states her case, and she tells the story of his past life. He is acquitted on her testimony which seems rather queer when she wasn't present at the killing. But this is no doubt motion picture license. The boy is reunited with his father after the acquittal.

"The Manicure Girl." (L. K. O. Sun., Dec. 27.)—This reel shows the scrimmages that take place between a number of rivals for the hand of a manicurist. Billie Ritchie is the leading rival. Quite a number of scenes depict the characters drinking water and then spitting it out of their mouths at each other. Louise Orth plays the name part. Many of the scenes transpire in a barber shop in which the colored bootblack is the shining light (not literally).

"Her Escape." (Rex. Two reels. Sun., Dec. 27.)—Not many dramas are as tense and full of action as this. The story shows how a girl raised among crooks broke away from her hereditary surroundings to lead a clean life, ending by marrying happily, with her criminal brother who had attempted to bring her back to the old life, dead. Produced by Joseph De Grasse, this film bears the marks of fine direction. Pauline Bush plays the part of the girl, Lon Chaney is her brother, William Dowlin her lover and Dick Rossin appears as a dope fiend.

"The Submarine Spy." (Imp. Two reels. Mon., Dec. 28.)—This is a reissue of the film of the same title released some time ago by the Universal. It concerns the heroic deed of a young naval officer who is in love with a captain's daughter. The spy in the case disables the submarine and it seems as if all would perish, but Billy, the hero, goes out through the submarine tube and brings help to those submerged. By this act he wins the captain's daughter and disposes of the villain.

"The Chef's Revenge." (Sterling. Mon., Dec. 28.)—There is slightly too much gesticulating by the principal players of this comedy to be enjoyed. A little less of it and the picture would be more pleasing. The chef of the restaurant is insulted by one of the patrons. He leaves the place, attempting to take with him all the waiters, but after quite a mixup they rebel. He finally blows himself, the proprietor, the cashier and the building up with a bomb. This comedy is better than the Sterlings have been of late, but could be improved upon if the movements be more spoken of were omitted.

"The Virtuoso." (Victor. Mon., Dec. 28.)—This picture is unconventional and rather disappointing as it is rightfully a drama until the last scene, which in a way transforms the entire story into a comedy. Mary Fuller as a violinist invades the office of Schurman, a man resembling to a great extent a vaudeville booking agent, impersonated by Charles Ogle. After she has played her composition, which we see on the screen acted by Mary Fuller and Charles Ogle, Schurman proposes to the young lady and she breaks her violin over his head. The story of the

song is perhaps slightly too long. Aside from this the picture will afford fair entertainment.

"When It Is One of Your Own." (Nestor. Tues., Dec. 29.)—Plain drama of the variety that makes one think. Murdock MacQuarrie leads the cast. Agnes Vernon plays his daughter. The old waiter sees many a girl led astray in the restaurant in which he is employed, but when it comes to his own daughter things end abruptly.

"A Study in Scarlet." (Gold Seal. Two reels. Tues., Dec. 29.)—A detective story adapted from Sir Arthur Conan Doyle's popular work. Francis Ford is cast as Holmes. Jack Francis gives rather a weak impersonation of Watson, and Harry Schumm plays the criminal in his usual style. The plot is for the most part the same as the original. The story has of course been condensed, but will provide ample entertainment for the lovers of the detective picture.

"The Romance of a Fat Girl." (Crystal. Tues., Dec. 29.)—This film far exceeds its predecessors of the same brand that have been appearing the past few weeks. It is a burlesque on the greatly exaggerated melodrama with the mortgage holder and one, Sir Charles, as the villain and hero respectively. The locale is supposedly Scotland, and the scenery and fake settings correspond with the general burlesque atmosphere of the whole picture. Charlie De Forrest appears as the gallant Sir Charles, and furnishes most of the fun. There are a number of laughs in this, and although the humor is of the rough variety it is not exceptionally vulgar, as it often is in this brand of pictures.

"Within an Inch of His Life." (Eclair. Two reels. Wed., Dec. 30.)—This is an adaptation of one of Eugene Manlove Rhodes' short stories, and presents a very enjoyable photoplay. It is convincingly played by a cast which is headed by Norbert Milcs as Wildcat Thompson and Edna Payne as the girl whose lover has been falsely convicted of murder. Wildcat takes pity on the girl and starts to work on the case, and in the end frees the lover of the girl. While this story is plain in plot it is really most pleasing to witness. The acting and direction throughout is of a superior quality. The scenes are carefully chosen, and are supported by photography of unusual excellence.

"The Village Postmaster." (Joker. Wed., Dec. 30.)—The rivalry of two country grocers for the position of postmaster and the subsequent inconvenience of the winner owing to the parcel post is the theme of this reel. It is cleverly acted by Ernest Shields, Eddie Boland and Phil Dunham. Excruciatingly funny from start to finish.

"Hounded." (Rex. Two reels. Thurs., Dec. 31.)—Not very pleasing but absorbing. The story of the released convict who was innocent, being hounded everywhere he goes, is the theme. This time the hounder is his father-in-law. The wife and child of the man die and he himself seeks oblivion.

"Love and Water." (Sterling. Thurs., Dec. 31.)—Jealousy is the cause of a great deal of trouble between two couples who appear in this reel. There is a lot of action that takes place on and in the water, which is fairly funny.

"Winning the Prize." (Imp. Thurs., Dec. 3.)—An old theme treated in a pleasing manner, with Charles Hutchinson in the role of the millionaire, and Elsie Albert as the girl he eventually marries. When the moneyed man declares himself bankrupt, all the other characters of the story except Elsie, true to motion picture convention, turn from him; Elsie, however, remains loyal. When it is discovered that the man is as rich as ever all the others return, but he prefers Elsie. Intertwoven with this is the story of a fishing contest, which Elsie causes the man she loves to win by placing a huge fish on his line. On the whole this will please, although the conclusion is well apparent at the start.

"Pruning the Movies." (Nestor. Fri., Jan. 1.)—A little knock is given by this picture to the state and city censor boards. Very humorously put, and a strictly unconventional idea.

"In Jungle Wilds." (101 Bison. Two reels. Sat., Jan. 2.)—These two reels are full of the trials that beset a family living in the wilds of an African jungle. The wild animals introduced keep up the suspense continually. The foolish jealousy of the husband leads to a thrilling adventure toward the end in which animals of various species play prominent parts. Some of the artificial jungle scenes are rather poorly set up, and really give the director's devices away. Aside from this fact and a few junglistic inconsistencies the picture is powerful. Marie Walcamp, Sherman Bainbridge and William Clifford are seen in the leading parts.

"The Beautiful Unknown." (Victor. Three reels. Fri., Jan. 1.)—Reviewed at length elsewhere in this issue.

"A Mixed Up Honeymoon." (Joker. Sat., Jan. 2.)—This is a hilarious offering. All the fun is due to hubby and wife coming home to find their house occupied by a newly married couple. Humorous situations are numerous until at last the four people pause and explanations follow. William Franey, Gale Henry, Milburn Moranti, Elsie Cort and Ralph McComas are the principals.

MUTUAL PROGRAM

"Shadows and Sunshine." (Princess. Fri., Dec. 18.)—A delightful little drama featuring the Thanhouser twins, Marion and Madeline Fairbanks. Two orphan babies are adopted, one by a rich family and the other by poor people. Years later, the poor child has grown up to be a thief. On the night that she and her father enter the house of the other, the man is killed and the other twin is adopted by the rich family. The scenes in the home of the well-to-do family are attractively real, and the scenes in the squalid tenement offer a striking contrast. The climax is well led up to and equally well played. The photography is good.

"The Beat of the Year." (Reliance. Two reels. Sat., Dec. 19.)—A conventional newspaper story in that a cub reporter succeeds in getting at the facts of a murder mystery which has baffled everyone else. However, the story of the murder is a good one. A millionaire's son has masqueraded as a poor factory employee. He had won a workman's sweetheart away from him, and as a result was followed by the girl's lover, who discovered the truth about him. As he was about to marry the girl under an assumed name the workman stopped him, and in the quarrel which followed killed him. The young reporter discovered part of this and then captured the fellow and induced him to confess the rest. Francelia Billington is seen as the girl, and Sam De Grasse and Eugene Palette are the rivals for her hand.

"A Colored Girl's Love." (Keystone. Sat., Dec. 19.)—The antics of two colored swains for the hand of a dark brown chicken, with a lot of feathered chickens on the side are very funny as interpreted by the able comedians who appear in the principal parts. This comedy will not give offense and will afford a number of laughs.

"Bill and Ethel at the Ball." (Komic. Mon., Dec. 20.)—Number 13 in the Bill series featuring Tammany Bill and Fay Tincher. It is an entertaining comedy, in which several strange situations are brought about by the fact that the stenographer's "steady" and her employer both wear the same costume at a masquerade ball. Fay Tincher continues to show her natural ability at comedy.

"The Sower Reaps." (American. Two reels. Mon., Dec. 21.)—After years of blackmail an old man is killed by his victim. The killing is actually in self-defense, but fearing to face an investigation he shifts the blame to the local schoolmaster and his criminally inclined brother. His better nature finally comes out, and he confesses. The indications are that he will not be prosecuted. Jack Richardson, William Garwood, Vivian Rich and Harry Von Meter play the principal roles.

"Our Mutual Girl, No. 49." (Reliance. Mon., Dec. 21.)—This reel is almost entirely taken up with a story of the adventures of an ex-cavalry officer from the U. S. A. who goes to a small European kingdom in search of a princess of the realm, whom he has met while she is traveling incognito in this country. The story is told by George Barr McCutcheon, when Norma Phillips, as the Mutual Girl, meets him and asks him the sort of story he likes best to write. His answer is the tale which fills the rest of the reel.

"Wild West Love." (Keystone. Mon., Dec. 21.)—Chester Conklin is always funny, but wearing cowboys' clothes in the same rakish style as he wears his others, he will cause laughter when one merely looks at him, and then when he starts his antics. He plays the part of Droppington. Droppington is in love, but desperately penniless. Droppington waxes brilliant and robs the stage, but he steals his own money, so "he should worry." Droppington wins the girl, he does, and everyone will be convulsed.

"Brass Buttons." (Beauty. Tues., Dec. 22.)—The story of two rivals in love made to appear very funny by the acting of the players and the comical situations conceived by the scenario writer. The girl in the case favors men in uniforms more than others. One of the rivals dresses as a cop and the other as a fireman to satisfy her. But the former is arrested for masquerading as a guardian of the law, while the latter is permitted to go and consequently wins the girl. The photography is fine.

(Continued on page 60.)

"SHOULD A WOMAN DIVORCE?" OPENS AT WEBER'S

Beginning Saturday, December 26, the Weber theatre, Broadway and Twenty-ninth street, New York, will open an engagement for an indefinite run with the five-reel photo-drama, "Should a Woman Divorce?" written and produced by Ivan Abramson, and staged by Edward McKim.

Lea Leland, who takes the part of Grace Roberts, ably portrays the character, proving herself a versatile student of human nature.

Her experience on the stage helped her to bring out the part artistically and dramatically. Miss Leland made her New York debut in "The Arcadians," and later appeared in "Madame Sherry." Her first dramatic appearance was in "Everywoman," in the character of Vice, which she played for three years.

Miss Leland, together with a carefully selected cast of well-known artists, helps to bring out every realistic detail of the photo-drama. The cast includes such artists as Anna Lehr, Mabel Wright, Laurie Mackin, Betty Holton, Bernice Raymon, Ordean Stark, Leonid Samoloff, Robert Taber, Frederic Roberts, George Egan and Milton S. Gould.

BREESE SEES HIMSELF IN "WALLS OF JERICHO"

Special to MOTION PICTURE NEWS

Philadelphia, Dec. 22

The manager of the Ruby Theatre, R. Marlow had a shock the other evening, when Edmund Breese, now playing at the Adelphia in "Today," quietly walked up and asked permission to see himself in "Walls of Jericho," which happened to be on at the Ruby, and in which Mr. Breese took the lead. Needless to say, the manager quickly recovered, and soon Mr. Breese was seeing himself as others saw him, to the mutual satisfaction of all concerned.

Exhibitors Will Own Stock in Exchange

Co-operative Service Company in Indianapolis, Handling Kriterion Program, Organized with Charles N. Stevenson and Harry R. Campbell as Officers

A NOVEL scheme for handling an exchange is being promoted in the Indianapolis territory for the Kriterion program.

A company has been incorporated and the exhibitors will own the stock in the exchange.

A meeting of the stockholders and exhibitors held for the purpose of examining films released by the Kriterion Program was held in Indianapolis on Monday, December 7, at the Starland theatre.

There was a splendid attendance and much enthusiasm created. The general opinion was that the films to be released through the Kriterion Program were as good as the best, judging from those exhibited Monday.

This scheme of handling an exchange is new in the film business, but since a weekly program of more than \$3,000 has been booked in the last three weeks with contracts signed up for a year in advance, it

Lasky Studio Is Notable California Landmark

Structure a Huge Glass House Instead of a Frame Building with Only a Skylight, Making a Bright Light Possible at All Times

WHEN Jesse L. Lasky reaches Los Angeles in the course of the next few days he will find some important changes at the Lasky Hollywood studios even though he has been in the East only since Thanksgiving Day. The biggest feature at the Western plant is the new glass studio

when electricity is used. The studio is also to be used for special lighting effects which cannot be obtained on the outdoor stage.

It is also of interest to note that this glass studio measures one hundred and fifty by two hundred feet, making it the largest indoor stage on the Pacific coast, accord-

TWO VIEWS OF THE NEW LASKY STUDIO AT HOLLYWOOD, CAL.



FINISHING THE FRAMEWORK

THE COMPLETED FLOOR

which was begun this fall, and which has been rushed to completion during Mr. Lasky's absence.

The glass studio is in a way an innovation. It differs decidedly from the usual indoor studio in that it is literally a glass building, instead of a frame structure with a large skylight, and one or two walls of glass. There is a skeleton of steel structure much like that used in constructing a greenhouse.

This is covered with glass panels with the result that the entire roof and the four walls are made of glass. This makes it possible to obtain a fine light except on the very darkest days of the rainy season,

ing to Mr. Lasky, and one of the largest in the country. In addition to this there is another studio building measuring sixty by one hundred and twenty feet located on the same property. These two buildings together with a large outdoor stage, available for the greater part of the year, will be used for all interiors.

Judging by Mr. Lasky's account, the most attractive feature of his plant is the ranch where exterior views are made. This is located only about twenty miles from the Hollywood studios and laboratories, but it includes every possible sort of scenery. The ranch, together with Government land on which the company has picture rights, covers an area of twenty thousand acres, or about thirty-one and a quarter square miles.

At the entrance is a stretch of absolutely barren sand, like a miniature scene from the heart of the Sahara. Beyond this there is a great diversity of country including mountains which rise to 6,000 feet above sea level, and on which snow scenes can be staged throughout most of the year.

On the ranch and at Hollywood there are about five hundred persons regularly employed. It is the policy of the Lasky company to build its own scenery and make its own costumes. In this way it is possible to stage pictures exactly as the directors wish and be entirely independent of the vagaries of the professional property dealers. The two Lasky plants thus represent one of the most complete establishments in the country for the making of motion picture films.

is not out of the ordinary to predict a tremendous success for the Kriterion Program in the Indianapolis exchange.

This program is handled by the Co-operative Service Company, 703 Odd Fellows building. Charles N. Stevenson is president, Harry R. Campbell, secretary and treasurer; Elmer Brient, vice-president and general manager.

The company proposes releasing in January.

FRED PERRY ENGAGED BY FAMOUS PLAYERS

The Famous Players Film Company have engaged Fred Perry, leading man in the current success, "On Trial," and who created the role of Redwood, the detective, in the original production of "Jim, the Penman," to portray that part in the film adaptation of this subject, which will shortly be presented with John Mason in the stellar role.

SELIG BUYS WING STORY

The Selig Polyscope Company has purchased the dramatic rights to the fiction story, "The Puny Soul of Peter Rand," from the author, William E. Wing. The story will be published in January, and soon thereafter will be followed by the screen release.

Record of Current and Coming Releases

GENERAL FILM PROGRAM

RELEASES OF NEXT WEEK

Monday, December 28, 1914.

BIOGRAPH—The House of Silence, D., 1000.....	16738
EDISON—Mr. Daly's Wedding Day, C., 1000.....	16744
ESSANAY—Sweedie Collects for Charity, C., 1000.....	16746
KALEM—The Black Sheep, D., 2000.....	16739
LUBIN—Patsy at School, Patsy Bolivar Series No. 1, C., 1000	16747
SELIG—Hearst-Selig News Pictorial No. 87, N., 1000..	16745
SELIG—The Flower of Faith, D., 2000.....	16741
VITAGRAPH—The Product, D., 1000.....	16743

Tuesday, December 29, 1914.

BIOGRAPH—The Crimson Moth, D., 2000.....	16755
EDISON—The Lesson of the Flames, D., 1000.....	16748
ESSANAY—The Way of the Woman, D., 1000.....	16749
KALEM—Love, Oil and Grease, C., 1000.....	16754
LUBIN—A Cowboy Pastime, C., 1000.....	16753
SELIG—Cactus Jake, Heart Breaker, C., 1000.....	16750
VITAGRAPH—Behind the Clouds, D., 2000.....	16751

Wednesday, December 30, 1914.

EDISON—The Courtship of the Cook, C., 1000.....	16757
ESSANAY—Two Dinky Little Dramas of a Non-Serious Kind, 1000	16760
KALEM—The Derelict, D., 2000.....	16758
LUBIN—The Intriguers, D., 2000.....	16763
SELIG—The Old Letter, D., 1000.....	16762
VITAGRAPH—Forcing Dad's Consent, C., 1000.....	16761

Thursday, December 31, 1914.

BIOGRAPH—Two Stray Souls, D., 1000.....	16765
ESSANAY—Snakeville's Rising Sons, C., 1000.....	16766
LUBIN—Fate and Fugitive, D., 2000.....	16767
MINA—The Siege of Liege, C., 1000.....	16771
SELIG—Hearst-Selig News Pictorial No. 88, N., 1000..	16770
VITAGRAPH—Love Will Out, D., 1000.....	16769

Friday, January 1, 1915.

BIOGRAPH—The Efficiency Squad, C., Diogenes Weekly No. 4-11-44, C., Split Reel.....	16780
EDISON—Young Mrs. Winthrop, D., 2,000.....	16772
ESSANAY—The Shanty at Trembling Hill, D., 2000...	16774
KALEM—Getting Father's Goat, C., 1000.....	16776
LUBIN—Clean Slate, D., 1000.....	16779
SELIG—Wipe Yer Feet, C., 1000.....	16777
VITAGRAPH—Antie's Portrait, C.; Rattlesnakes, Ed., Split Reel	16778

Saturday, January 2, 1915.

BIOGRAPH—All for the Boy, D., 1000.....	16787
EDISON—Uncle Crusty, C., 1000.....	16781
ESSANAY—Broncho Billy and the Escaped Bandit, D., 1000	16782
KALEM—The Girl Telegrapher's Peril, D., 1000.....	16786
LUBIN—He Gave Him a Million, C.; What He Forgot, C., Split Reel.....	16783
SELIG—Lassoing a Lion, D., 1000.....	16788
SELIG (Special)—Cinderella (Fairy Tale), 3000.....	087
VITAGRAPH—In the Latin Quarter, D., 2000.....	16784

RELEASES OF THE WEEK AFTER

Monday, January 4, 1915.

BIOGRAPH—From the Shadow, D., 1000.....	
EDISON—The Champion Process Server, C., 1000...	
ESSANAY—Sweedie and the Sultan's Present, C., 1000	
KALEM—Cast Up by the Sea, D., 2000.....	
LUBIN—Patsy's First Love, C., 1000.....	
SELIG—Hearst-Selig News Pictorial, No. 89, N., 1000	
SELIG—The Strange Story of Princess Khon, D., 2000	
VITAGRAPH—Flora 4 Flush (Treachery in the Clouds), C., 1000.....	

Tuesday, January 5, 1915.

BIOGRAPH—Money, D., 2000.....	
EDISON—Olive and the Burglar, D., 1000.....	
ESSANAY—The Gallantry of Mr. Jimmie Rogers, C., 1000	
KALEM—The Waitress and the Boob, C., 1000.....	
LUBIN—The New Editor and They Looked Alike, C., Split Reel	
SELIG—A Militant School Ma'am, C., 1000.....	
VITAGRAPH—Two Women, D., 3000.....	

Wednesday, January 6, 1915.

EDISON—Expensive Economy, C., 1000.....	
ESSANAY—The Fable of the City Grafter and the Unprotected Rubes, C., 1000.....	
KALEM—The Scorpion's Sting, D., 2000.....	
LUBIN—Comrad Kitty, D., 2000.....	
SELIG—In the Line of Duty, D., 1000.....	
VITAGRAPH—Billy's Wager, C., 1000.....	

Thursday, January 7, 1915.

BIOGRAPH—Playthings of Fate, D., 1000.....	
ESSANAY—The Battle of Snakeville, C., 1000.....	
LUBIN—A War Baby, D., 2000.....	
MINA—Alias "Greased Lightning," C., 1000.....	
SELIG—Hearst-Selig News Pictorial, No. 90, N., 1000	
VITAGRAPH—The Man, the Mission and the Maid, C., 1000	

Friday, January 8, 1915.

BIOGRAPH—The Barrier Between, D., 1000.....	
EDISON—The Magnate of Paradise, D., 2000.....	
ESSANAY—Surgeon Warren's Ward, D., 2000.....	
KALEM—Put Me Off at Wayville, C., 1000.....	
LUBIN—Love's Savage Hate, D., 1000.....	
SELIG—The Strenuous Life, C., 1000.....	
VITAGRAPH—The Smoking Out of Bella Butts, C., 1000	

Saturday, January 9, 1915.

BIOGRAPH—A Safe Adventure, C.; The Fashion Shop, C., Split Reel.....	
EDISON—The Girl at the Key, D., 1000.....	
ESSANAY—Broncho Billy and the Claim Jumpers, D., 1000	
KALEM—The Leap from the Water Tower, D., 1000	
LUBIN—Feel My Muscle, C., 1000.....	
SELIG—Further Adventures of Sammy Orpheus, C., 1000	
VITAGRAPH—A Daughter of Israel, D., 2000.....	

RECCRD OF CURRENT AND COMING RELEASES — Continued

UNIVERSAL PROGRAM

RELEASES OF NEXT WEEK

Monday, December 28, 1914.

IMP—The Submarine Spy, D., 2000..... 4459
 POWERS—Fickle Elsie, C., 1000..... 4462
 VICTOR—Mary Fuller in "Virtuoso," D., 1000..... 4461

Tuesday, December 29, 1914.

CRYSTAL—The Fat Girl's Romance, C., 1000..... 4467
 GOLD SEAL—A Study in Scarlet, D., 2000..... 4465
 NESTOR—When Its One of Your Own, D., 1000..... 4468

Wednesday, December 30, 1914.

ANIMATED WEEKLY—Weekly No. 147, N., 1000.... 4473
 ECLAIR—Within an Inch of His Life, D., 2000..... 4470
 JOKER—The Village Post Master, C., 1000..... 4469

Thursday, December 31, 1914.

IMP—Winning the Prize, D., 1000..... 4474
 REX—Hounded, D., 2000..... 4475
 STERLING—Love and Water, C., 1000..... 4477

Friday, January 1, 1915.

NESTOR—Pruning the Movies and Mt. St. Bernard, Switzerland, Split Reel..... 4478
 POWERS—No Release This Week.....
 VICTOR—The Beautiful Unknown, D., 3000..... 4480

Saturday, January 2, 1915.

101 BISON—In Jungle Wilds, D., 2000..... 4485
 FRONTIER—Christmas at Lonesome Gulch, D., 1000.. 4484
 JOKER—A Mixed Up Honeymoon, C., 1000..... 4483

Sunday, January 3, 1915.

ECLAIR—The Hermit's Secret, D., 1000..... 4490
 L-KO—Gem and Germs, C., 1000..... 4489
 REX—The Sin of Olga Brandt, D., 2000..... 4487

RELEASES OF THE WEEK AFTER

Monday, January 4, 1915.

IMP—Three Times and Out, C., 1000..... 0102
 STERLING—Olive's Love Affair, C., 1000..... 0103
 VICTOR—Terence O'Rourke, a Captain of Villainy, C., 2000 0101

Tuesday, January 5, 1915.

BIG U—His Last Performance, D., 1000..... 0105
 GOLD SEAL—The Mystery of the Throne Room, Lady Raffles Series, D., 2000..... 0104
 NESTOR—For the Good of the Cause, D., 1000..... 0106

Wednesday, January 6, 1915.

ANIMATED WEEKLY—Weekly No. 148, N., 1000.... 0108
 ECLAIR—The Collingsby Pearls, D., 2000..... 0107
 L-KO—Cupid in a Hospital, C., 1000..... 0109

Thursday, January 7, 1915.

BIG U—On Desert Sands, D., 2000..... 0110
 REX—A Man's Temptation, D., 1000..... 0111
 STERLING—Those German Bowlers, C., 1000..... 0112

Friday, January 8, 1915.

IMP—She Was His Mother, D., 3000..... 0113
 NESTOR—When His Lordship Proposed, C., 1000..... 0115
 VICTOR—No Release This Week.....

Saturday, January 9, 1915.

101 BISON—Custer's Last Scout, D., 2000..... 0116
 JOKER—A Political Mess and A Modern Poultry Farm, Split Reel 0118
 POWERS—A Girl of the Pines, D., 1000..... 0117

Sunday, January 10, 1915.

ECLAIR—The Dummy Husband, C., 1000..... 0120
 L-KO—Through a Knot Hole, C., 1000..... 0121
 REX—Star of the Sea, D., 1000..... 0119

MUTUAL PROGRAM

RELEASES OF NEXT WEEK

Monday, December 28, 1914.

AMERICAN—When a Woman Waits, D., 2000..... 02792
 KEYSTONE—Title Not Announced, C., 1000..... 02795
 RELIANCE—Our Mutual Girl, No. 50..... 02796

Tuesday, December 29, 1914.

BEAUTY—Love Knows No Law, D., 1000..... 02800
 MAJESTIC—Baby's Ride, 1000..... 02799
 THANHOUSER—Lucy's Elopement, 2000..... 02797

Wednesday, December 30, 1914.

AMERICAN—The Unseen Vengeance, D., 1000..... 02804
 BRONCHO—The Face on the Ceiling, D., 2000..... 02802
 RELIANCE—The Message, 1000..... 02805

Thursday, December 31, 1914.

DOMINO—The Flower in the Desert, D., 2000..... 02807
 KEYSTONE—Title Not Announced..... 02809
 MUTUAL WEEKLY—No. 105, N., 1000..... 02810

Friday, January 1, 1915.

KAY-BEE—The Deadly Spark, D., 200..... 02812
 PRINCESS—When Fate Rebelled, D., 1000..... 02814
 THANHOUSER—Shep the Sentinel, D., 1000..... 02815

Saturday, January 2, 1915.

KEYSTONE—Title Not Announced..... 02818
 RELIANCE—A Banakie Maiden, D., 2000..... 02816
 ROYAL—Putting It Over, 1000..... 02819

Sunday, January 3, 1915.

KOMIC—Ethel Gets the Evidence (Bill, No. 14), C., 1000 02822
 MAJESTIC—Vengeance Is Mine, D., 2000..... 02820
 THANHOUSER—The Bridal Bouquet, D., 1000..... 02823

RELEASES OF THE WEEK AFTER

Monday, January 4, 1915.

AMERICAN—The Legend Beautiful, D., 2000.....
 KEYSTONE (Special)—Hushing the Scandal, C., 2000
 KEYSTONE—Title Not Announced, C., 1000.....
 RELIANCE—Our Mutual Girl, No. 51, 1000.....

Tuesday, January 5, 1915.

BEAUTY—In the Vale of Sorrow, D., 1000.....
 MAJESTIC—His Lesson, D., 1000.....
 THANHOUSER—The Menacing Past, D., 2000.....

Wednesday, January 6, 1915.

AMERICAN—The Alarm of Angelon, D., 1000.....
 BRONCHO—The Scourge of the Desert, D., 2000...
 RELIANCE—A Night's Adventure, D., 1000.....

Thursday, January 7, 1915.

DOMINO—The Scrub, D., 2000.....
 KEYSTONE—Title Not Announced, C., 1000.....
 MUTUAL WEEKLY—No. 106, N., 1000.....

Friday, January 8, 1915.

KAY BEE—A Midas of the Desert, D., 2000.....
 PRINCESS—Check Number 30, D., 1000.....
 MAJESTIC—Branch No. 37, D., 1000.....

Saturday, January 9, 1915.

KEYSTONE—Title Not Announced, C., 1000.....
 RELIANCE—The Lost Receipt, D., 2000.....
 ROYAL—Married by Installment, C., 1000.....

Sunday, January 10, 1915.

KOMIC—Love and Business, C., 1000.....
 MAJESTIC—Three Brothers, D., 3000.....
 THANHOUSER—An Inside Tip, D., 1000.....

RELEASE DATES FOR READY REFERENCE

GENERAL FILM PROGRAM

BIOGRAPH

- 12-18. His Prior Claim, D.....1000
- 12-19. The Bond Sinister, D.....1000
- 12-21. A Matter of Court, C., and The Dentist's Janitor, C.....Split reel
- 12-22. On the Heights, D.....2000
- 12-24. The Suffering of Susan, C.....1000
- 12-25. The Way Home, D.....1000
- 12-26. His Unwitting Conquest.....1000
- 12-28. The House of Silence, D.....1000
- 12-29. The Crimson Moth, D.....2000
- 12-31. Two Stray Souls, D.....1000
- 1-1. The Efficiency Squad, C., and Diogenes Weekly No. 4-11-44, C.....Split Reel
- 1-2. All for the Boy, D.....1000
- 1-4. From the Shadow, D.....1000
- 1-5. Money, D.....2000
- 1-7. Playthings of Fate, D.....1000
- 1-8. The Barrier Between, D.....1000
- 1-9. The Fashion Shop, C., and A Safe Adventure, C., split reel.....1000

EDISON

- 12-15. The Vanishing of Olive, D.....1000
- 12-16. On Christmas Eve, D.....1000
- 12-18. The Colonel of the Red Hussars, D.....1000
- 12-19. The Birth of Our Saviour, D.....1000
- 12-21. The Adventures of the Wrong Santa Claus, C.....1000
- 12-22. Olive Is Dismissed, D.....1000
- 12-23. 'Twas the Night Before Christmas, Fant.....550
- The Tip of the Dark Continent, E.. 450
- 12-25. The Premature Compromise, D.....2000
- 12-26. The Man Who Vanished, D.....1000
- 12-28. Dr. Daly's Wedding Day, C.....1000
- 12-29. The Lesson of the Flames, D.....1000
- 12-30. The Courtship of the Cooks, C.....1000
- 1-1. Young Mrs. Winthrop, D.....2000
- 1-2. Uncle Crusty, C.....1000
- 1-4. The Champion Process Server, C.....1000
- 1-5. Olive and the Burglar, D.....1000
- 1-6. Expensive Economy, C.....1000
- 1-8. The Magnet of Paradise, D.....2000
- 1-9. The Girl at the Key, D.....1000
- 1-11. A Superfluous Baby, C.....1000
- 1-12. Olive's Other Self, D.....1000
- 1-13. Curing the Cook, C.....450
- McGinty and the Count, C.....550
- 1-15. Lena, C.....2000

ESSANAY

- 12-15. Loose Change of Chance.....
- 12-16. Two Pop-Up Fables, C.....
- 12-17. Snakeville's Blind Pig, C.....1000
- 12-18. The Girl from Thunder Mountain, D.....1000
- 12-19. Broncho Billy's Christmas Spirit, D.....1000
- 12-19. The Battle of Love (Special Feature), D.....3000
- 12-21. Their Cheap Vacation, C.....1000
- 12-22. The Volunteer Burglar, D.....1000
- 12-23. The Fable of "The Husband Who Showed Up and Did His Duty," C.....1000
- 12-24. Slippery Slim Gets Square, C.....1000
- 12-26. Broncho Billy and the Sheriff's Office, D.....1000
- 1-1. The Shanty at Trembling Hill, D.....2000
- 1-2. Broncho Billy and the Escaped Bandit, D.....1000
- 1-4. Sweedie and the Sultan's Present, C.....1000
- 1-5. The Gallantry of Mr. Jimmy Rogers, D.....1000
- 1-6. "The Fable of the City Grafter and the Unprotected Rubes," C.....1000
- 1-7. The Battle of Snakeville, C.....1000
- 1-9. Broncho Billy and the Claim Jumpers, D.....1000

KALEM

- The School for Scandal, D.....4000
- 12-18. Through the Keyhole, C.....1000
- 12-19. The Black Diamond Express, Hazards of Helen, D.....1000
- 12-21. The Mayor's Secretary, Alice Joyce Series, D.....2000
- 12-22. The Winning Whiskers, C.....1000
- 12-23. The Fatal Opal, D.....2000
- C., The Reformation of Ham, C.....1000
- SELIG—The Escape on the Limited, D.....1000
- SELIG—A Black Sheep, D.....2000
- SELIG (Sp)—Oil and Grease, C.....1000
- SELIG—Derelict, D.....2000
- VITAGRAPH—Father's Goat, C.....1000
- 1-1. Telegrapher's Peril, D.....1000

- 1-4. Cast Up by the Sea, D.....2000
- 1-5. The Waitress and the Boobs, C.....1000
- 1-6. The Scorpion's Sting, D.....1000
- 1-8. Put Me Off at Wayville, C.....1000
- 1-9. The Leap from the Water Tower, D.....1000

LUBIN

- 12-25. The Lure of the Green Table, D.....1000
- 12-26. Brannigan's Band, C.....400
- A Troublesome Cat, C.....600
- 12-28. Patsy Bolivar Series, No. L, Patsy at School, C.....1000
- 12-29. A Cowboy Pastime, C.....1000
- 12-30. The Intriguers, D.....2000
- 12-31. Fate and Fugitive, D.....2000
- 1-1. A Clean Slate, D.....1000
- 1-2. He Gave Him a Million, C.....400
- 1-4. What He Forgot, C.....600
- 1-4. Patsy Bolivar, Series No. 2, Patsy's First Love, C.....1000
- 1-5. The New Editor, C.....400
- 1-6. They Looked Alike, C.....600
- 1-6. Comrade Kitty, D.....2000
- 1-7. A War Baby, D.....2000
- 1-8. Love's Savage Hate, D.....1000
- 1-9. Feel My Muscle, C.....1000
- 1-11. Patsy Bolivar, Series No. 3, Patsy at College, C.....1000
- 1-12. Baseball and Trouble, C.....1000

RELEASE DAYS

GENERAL FILM PROGRAM

- Monday—Biograph, Edison, Essanay, Hearst-Selig News Pictorial, Kalem, Selig, Vitagraph.
- Tuesday—Biograph, Edison, Essanay, Lubin, Selig, Vitagraph.
- Wednesday—Edison, Essanay, Kalem, Lubin, Selig, Vitagraph.
- Thursday—Biograph, Essanay, Hearst-Selig News Pictorial, Lubin, Mina, Selig, Vitagraph.
- Friday—Biograph, Edison, Essanay, Kalem, Selig, Lubin, Vitagraph.
- Saturday—Biograph, Edison, Essanay, Kalem, Lubin, Vitagraph, Selig.

UNIVERSAL PROGRAM

- Monday—Victor, Imp, Powers.
- Tuesday—Gold Seal, Crystal, Nestor.
- Wednesday—Nestor, Joker, Eclair.
- Thursday—Imp, Rex, Frontier, Sterling, Animated Weekly.
- Friday—Nestor, Powers, Victor.
- Saturday—Joker, Frontier, 101 Bison.
- Sunday—Rex, Crystal, Eclair, L-KO.

MUTUAL PROGRAM

- Monday—American, Keystone, Reliance.
- Tuesday—Beauty, Majestic, Thanouser.
- Wednesday—American, Broncho, Reliance.
- Thursday—Domino, Keystone, Mutual Weekly.
- Friday—Kay-Bee, Majestic, Princess.
- Saturday—Keystone, Reliance, Royal.
- Sunday—Majestic, Komic, Thanouser.

- 1-13. When Honor Wakes, D.....2000
- 1-14. The Friendship of Lamond, D.....2000
- 1-15. Out of the Storm, D.....1000
- 1-16. Mr. Stubb's Pen, C.....400
- Spaghetti and Lottery, C.....600

MINA

- 12-17. The Thrilling Adventures of Count Verance, C.....1000
- 12-24. A High Old Time, C.....1000
- 12-31. The Siege of Liege, C.....1000
- 1-7. Alias "Greeded Lightning",.....1000
- 1-14. Distilled Spirits.....1000

SELIG

- 12-15. The Man From the East.....1025
- 12-16. The Test.....1000
- 12-17. Hearst-Selig News No. 84.....1000
- 12-18. The Tail of a Coat.....850
- 12-19. The Lady or the Tigers, D.....1000
- 12-21. Till Death Do Us Part, D.....2000
- 12-21. Hearst-Selig News No. 85.....1000
- 12-22. Wade Brent Pays, D.....1000
- 12-23. One Traveler Returns.....1000
- 12-24. Hearst-Selig News Pictorial No. 86, N.1000
- 12-26. Between Matinee and Night.....1025
- 12-28. The Flower of Faith, D.....2000
- 12-29. Cactus Jake, Heart-Breaker, C.....1000
- 12-29. Hearst-Selig News Pictorial No. 87, N.1000
- 12-30. The Old Letter, D.....1000

- 12-31. Hearst-Selig News Pictorial No. 88, N.1000
- The Champion Bear Slayer.....1000
- 1-1. Wipe Your Feet, C.....1000
- 1-2. Lassoing a Lion, D.....1000
- 1-4. Hearst-Selig News Pictorial No. 89.....1000
- 1-4. The Strange Story of Princess Khon, D.....2000
- 1-5. A Militant Schoolma'am, C.....1000
- 1-6. In the Line of Duty, D.....1000
- 1-7. Hearst-Selig News Pictorial No. 90.....1000
- 1-8. The Strenuous Life, C.....1000
- 1-9. Further Adventures of Sammy Orpheus, D.....1000

VITAGRAPH

- 12-18. Who Was Who in Hogg's Hollow, C.1000
- 12-19. Mr. Santa Claus, C.....2000
- 12-21. Arthur Truman's Ward, D.....1000
- 12-22. By the Governor's Order, D.....2000
- 12-23. The Professor's Romance, C.....1000
- 12-24. The Knight Before Christmas, D.....1000
- 12-25. Sweeney's Christmas Bird, C.....1000
- 12-26. An Affair for the Police, C.....2000
- 12-28. The Product, D.....1000
- 12-29. The Plot, D.....2000
- 12-30. Forcing Dad's Consent, C.....1000
- 12-31. Love Will Out, C.....1000
- 1-1. Auntie's Portrait, C., and Rattlesnakes, Ed.....Split Reel
- 1-2. In the Latin Quarters, D.....2000
- 1-4. Flora Four Flush (Treachery in the Clouds), C.....1000
- 1-5. Two Women, D.....3000
- 1-6. Billy's Wager, C.....1000
- 1-7. The Man, the Mission and the Maid, C.....1000
- 1-8. The Smoking Out of Bella Butts, C.1000
- 1-9. A Daughter of Israel, D.....2000

UNIVERSAL PROGRAM

ANIMATED WEEKLY

- Issued Every Wednesday.
- BIG U
- 1-5. His Last Performance, D.....1000
- 1-7. On Desert Sands.....1000

101 BISON

- 12-19. The Christmas Spirit, D.....2000
- 12-26. The Law of the Range, D.....3000
- 1-2. In Jungle Wilds, D.....2000
- 1-9. Custer's Last Scout, D.....2000
- 1-16. The Governor Maker, D.....2000

CRYSTAL

- 12-1. Charlie Woos Vivian, and The Barber Shop Feud; split reel.....1000
- 12-8. Vivian's Cookies, and Whose Baby, C.; split reel.....1000
- 12-15. Such a Mistake, and The Glass Pistol; split reel.....1000
- 12-22. Vivian's Beauty, C.....1000
- 12-29. The Fat Girl's Romance, C.....1000

ECLAIR

- 12-9. For the Mastery of the World, D.....3000
- 12-13. The Mountain Traitor, D.....1000
- 12-16. A Game of Wits, D.....2000
- 12-23. The Fortunes of Margaret, D.....2000
- 12-27. For the Defence, D.....1000
- 12-30. Within an Inch of His Life, D.....2000
- 1-3. The Hermit's Secret, C.....1000

FRONTIER

- 12-5. The Circle of Gold, D.....1000
- 12-12. Her Higher Ambition, D.....1 reel
- 1-2. Christmas at Lonesome Gulch, D.....1000

GOLD SEAL

- 12-1. Called Back, D.....4000
- 12-8. The District Attorney's Brother, D.....2000
- 12-15. The Ghost of Smiling Jim, D.....2000
- 12-22. The Call of the Waves, D.....2000
- 12-29. A Study in Scarlet, D.....2000
- 1-5. The Mystery of the Throne Room, My Lady Raffles Series, D.....1000
- 1-12. What a Woman Will Do, D.....2000

IMP

- 11-23. His Gratitude, Mary Pickford, Re-issue, D.....1000
- 11-26. Human Hearts, D.....3000
- 11-30. The Coward, D.....2000
- 12-3. The Young Philanthropist, D.....1000
- 12-7. The Outcome, Mary Pickford Reissue, D.....1000



REMEMBER that MinA Films are no haphazard catch-as-catch-can films rushed out pell mell to grab off some of the coin loosened up by the present day craze for comedies.

MinA Films represent a serious effort to produce the finest one reel comedies possible.

Work was started on MinA Films months ago, when the great demand for comedies was just commencing. Since that time many producers have entered the field with hurry-up brands of comedies. But the makers of

MINA

FILMS

realized that comedies are beyond comparison the most difficult pictures to produce. So they *specialized* on comedies, and held back MinA Films until months of study and experiment had developed a system of production that guarantees sure fire results.

MinA Films employ *special* scenario writers, *special* directors, *special* camera men, *special* comedians, *specialists* in every department. MinA Films are being exploited for the exhibitor through the news columns of nearly seven hundred papers in all parts of the country, thus creating popular interest which is directly connected with your theatre through beautiful one and three sheet posters.

The fact that MinA Films are included in the licensed program should convince you of their sound, reliable quality.

Released every Thursday on the

GENERAL FILM PROGRAM

RELEASE DATES FOR READY REFERENCE — Continued

12—10. Three Men Who Knew, D.....2000
 12—14. The Mill Stream, D.....2000
 12—17. Within the Gates of Paradise, Christmas Drama, D.....1000
 12—21. In Sunny Spain, Mary Pickford Release, C.....1000
 12—28. The Submarine Spy, D.....2000
 12—31. Winning the Prize, C.....1000
 1—4. Three Times and Out, C.....1000
 1—8. She Was His Mother, D.....3000
 1—15. A Gentleman of Art, D.....3000

JOKER

12—9. The Genii of the Vase, and Alaska, E., split reel.....1000
 12—12. Love Disguised, and Building a Locomotive, E., split reel.....1000
 12—16. How Father Won Out, and The Advent of the Ingrar Neilson, D.....2000
 12—19. His Doctor's Orders, C.....1000
 12—22. Love and Spirits, C.....1000
 12—26. Christmas Festivities, C.....1000
 12—30. The Village Post Master, C.....1000
 1—2. A Mixed Up Honeymoon, C.....1000
 1—4. Two of a Kind, C.....1000
 1—9. A Political Mess and The Modern Poultry Farm; split reel.....1000

L-K

12—20. The Baron's Bear Escape, C.....1000
 12—27. The Manicure Girl, C.....1000
 1—3. Gem and Germs, C.....1000
 1—6. Cupid in a Hospital, C.....1000
 1—10. Through a Knot Hole, C.....1000

NESTOR

11—13. When the Girls Were Shanghaied, C.....1000
 11—20. When Their Brides Got Mixed, C.....1000
 India's Defender of the British Empire; split reel.....1000
 11—24. As We Journey Through Life, D.....1000
 12—8. The Widows Last, D.....1 reel
 12—11. Their Ups and Downs, C.....1 reel
 12—15. The Boy Mayor, D.....1000
 12—18. His Dog Gone Luck, and Here and There in Japan with Homer Croy.....1000
 12—22. For I Have Told, D.....1000
 12—25. Who Stole the Bridegroom? C.....1000
 12—29. When It's One of Your Own, D.....1000
 1—1. Pruning the Movies, C, and Mt. St. Bernard, Switzerland, E.....Split Reel
 1—5. For the Good of the Cause, D.....1000

POWERS

11—20. A Scenario Editor's Dream, C.....1000
 11—27. Sissy Dobbins, Oil Magnate, D.....1000
 12—4. The Heart of a Magdalene, D.....1000
 12—11. Adventures of the Nimble Dollar, D.....1000
 12—25. Hunting in Crazyland, Cart, and The Japanese Silk Industry, E.....1000
 1—9. A Girl of the Pines, D.....1000

REX

11—22. Traffic in Babes, C.....2000
 11—26. Slow, but Sure, C.....2000
 11—29. Lights and Shadows, D.....2000
 12—3. The Mystery of the Sea View Hotel, D.....2000
 12—6. The Lion, the Lamb and the Man, D.....2000
 12—13. A Night of Thrills, D.....2000
 12—17. Ambition, D.....2000
 12—20. A Page from Life, D.....2000
 12—24. The Big Sister's Christmas, D.....2000
 12—27. Her Escape, D.....2000
 12—31. Hounded, D.....2000
 1—3. The Sin of Olga Brandt, D.....2000
 1—7. A Man's Temptation, D.....1000
 1—10. Star of the Sea, D.....2000

STERLING

12—24. Innocent Dad, C.....1000
 12—28. The Chef's Revenge, C.....1000
 12—31. Love and Water, C.....1000
 1—7. Olive's Love Affair, C.....1000
 1—14. Those German Bowlers, C.....1000

VICTOR

12—7. Terence O'Rourke—The Inn of the Winged Gods, D.....2000
 12—11. The Little Gray House, D.....2000
 12—14. The Wayward Son, D.....1000
 12—18. Mary Fuller, in Heart of the Hills, D.....3000
 12—21. Terence O'Rourke, "The King and The Man," D.....2000
 12—25. The Accusation, D.....2000

12—28. Mary Fuller in Virtuoso, D.....1000
 1—1. The Beautiful Unknown, D.....3000
 1—4. Terence O'Rourke—A Captain of Villainy, D.....2000
 1—11. Mary Fuller in "My Lady High and Mighty, C.....1000

MUTUAL FILM PROGRAM

AMERICAN

12—14. In Tune, D.....2000
 12—16. The Silent Way, D.....1000
 12—18. Trapped by a Heliograph, D.....1000
 12—21. The Sower Reaps, D.....2000
 12—23. The Tin Can Shack, D.....1000
 12—28. When a Woman Waits, D.....2000
 12—30. The Unseen Vengeance, D.....1000
 1—4. The Legend Beautiful, D.....2000
 1—6. The Alarm of Angelou, D.....1000
 1—11. Restitution, D.....2000
 1—13. Black Ghost Bandit, D.....1000

BEAUTY

12—8. Limping Into Happiness, C.....1000
 12—15. Her Younger Sister, D.....1000
 12—22. Brass Buttons, C.....1000
 12—29. Love Knows No Law, D.....1000
 1—5. In the Vale of Sorrow, D.....1000
 1—12. The Spirit of Giving, D.....1000

BRONCHO

12—16. The Panther.....2000
 12—28. The Passing of Two Gun Hicks.....2000
 12—30.—Face on the Ceiling, D.....2000
 1—6. The Scourge of the Desert, D.....2000
 1—13. Mother Hulda, D.....2000

DOMINO

12—10. Not of the Flock.....2000
 12—17. The Political Feud.....2000
 12—24. The Last of the Line, D.....2000
 12—31. Flower in the Desert, D.....2000
 1—7. The Scrub, D.....2000
 1—14. In the Land of the Otter, D.....2000
 1—21. The Still on Sunset Mountain, D.....2000

KAY-BEE

12—4. Mother of the Shadows.....2000
 12—11. Fortunes of War.....2000
 12—18. The Game of Life, D.....2000
 12—25. In the Sage Bush Country, D.....2000
 1—1. The Deadly Spark, D.....2000
 1—8. A Midas of the Desert, D.....2000

KEYSTONE

11—19. The Noise of Bombs, C.....1000
 11—21. Fatty's Wine Party, C.....1000
 11—23. His Taking Ways, C.....1000
 11—23. The Sea Nymphs, C, special.....1000
 11—26. His Halted Career, C.....1000
 11—28. Among the Mourners, C.....1000
 11—30. Leading Lizzie Astray, C.....1000
 12—3. Shotguns That Kick, C.....1000
 12—5. Getting Acquainted, C.....1000
 12—7. His Pre-Historic Past, special.....2000
 12—7. Other People's Business, C.....1000
 12—10. The Plumber, C.....1000
 12—12. Ambrosio's First Falsehood, C.....1000
 12—14. Fatty's Magic Pants, C.....1000
 12—17. Hogan's Annual Spree, C.....1000
 A Colored Girl's Love, C.....1000
 12—21. Fatty and Minnie He-Haw (Special).....2000
 12—21. Wild West Love, C.....1000
 12—24. A Fatal Bumping, C.....1000
 12—26. His Second Childhood.....1000
 1—4. Hushing the Scandal (Special), C.....2000

KOMIC

12—27. The Record Breaker.....1000
 1—3. Ethel Gets the Evidence, C.....1000
 1—10. Love and Business, C.....1000
 1—17. Bill No. 15, C.....1000
 1—24. A Flurry in Art, C.....1000
 1—31. Cupid and the Test, C.....1000

MAJESTIC

12—6. A Question of Courage.....1000
 12—8. Her Brave Hero.....1000
 12—11. In Wildman's Land.....1000

12—13. The Old Maid, D.....2000
 12—15. At Dawn.....1000
 12—20. In Fear of His Past.....2000
 12—22. The Better Way.....1000
 12—27. How Hazel Got Even.....2000
 12—29. Baby's Ride.....1000
 1—5. His Lesson, D.....1000
 1—8. Branch No. 37, D.....1000
 1—10. Three Brothers, D.....2000
 1—12. Probation, D.....1000

PRINCESS

11—27. The Wild, Woolly West.....1000
 12—4. The Creator of Hunger.....1000
 12—11. In the Conservatory, D.....1000
 12—18. Shadows and Sunshine, D.....1000
 12—25. The White Rose.....1000
 1—1. When Fate Rebelled, D.....1000
 1—8. Check Number 30, D.....1000

RELIANCE

12—2. The Lucky Shot.....1000
 12—5. Whot Shot Bud?.....1000
 12—7. Our Mutual Girl, No. 47.....1000
 12—9. Forest Thieves.....1000
 12—12. On the Ledge.....2000
 12—14. Our Mutual Girl, No. 48.....1000
 12—16. The Joke on Yelltown.....1000
 12—19. The Beat of the Year.....1000
 12—21. Our Mutual Girl, No. 49.....1000
 12—23. A Lucky Disappointment.....1000
 12—25. Bobby's Medal.....1000
 12—26. The Exposure.....2000
 12—28. Our Mutual Girl, No. 50.....1000
 12—30. The Message.....1000
 1—2. A Banakie Maiden, D.....2000
 1—4. Our Mutual Girl No. 51.....1000
 1—6. A Night Adventure, D.....1000
 1—9. The Last Receipt, D.....2000
 1—11. Our Mutual Girl No. 52.....1000
 1—13. The Terror of the Mountain, D.....1000

ROYAL

12—21. Love Finds a Way.....1000
 11—28. Before and After.....1000
 12—5. Sherman Was Right—It's Very Trying.....1000
 12—12. Percy the Milliner, C.....1000
 12—19. Two Kisses.....1000
 12—26. Her Mother's Voice.....1000
 1—2. Putting It Over, C.....1000
 1—9. Married by Installment, C.....1000

THANHOUSER

11—22. A Messenger of Gladness.....1000
 11—24. Mrs. Van Ruyter's Stratagem.....2000
 11—29. A Denver Romance.....1000
 12—1. The Center of the Web.....2000
 12—4. Naidra, the Dream Woman.....1000
 12—6. The Amateur Detective.....1000
 12—8. The Reader of Minds.....2000
 12—13. When East Meets West.....1000
 12—15. The Barrier of Flames.....2000
 12—20. Sid Nee's Finish.....1000
 12—22. Under False Colors.....1000
 12—27. A Hatful of Trouble.....1000
 12—29. Lucy's Elopement.....1000
 1—1. Shep the Sentinel, D.....1000
 1—3. The Bridal Bouquet.....1000
 1—5. The Menacing Past, D.....2000
 1—10. An Inside Tip.....1000
 1—12. The Speed King, D.....2000
 1—17. A Yellowstone Honeymoon.....1000
 1—19. Craft vs. Love, D.....2000
 1—24. The Dog Catcher's Bride, C.....1000

UNITED FILM SERVICE WARNER'S FEATURES, INC.

EVANS

Bangs' Burglar.....1 reel
 12—23. Five Senses, and When the Lilly Died.....Split reel
 12—28. For Love of Princess Yolande....2 reels

FEATURES IDEAL

12—1. The Wolf's Prey, D.....3000
 Her Duplicate Husband.....3 reels
 12—23. Lash of Fate.....2 reels
 12—30. Honor of Bill Jackson.....2 reels
 1—4. The Blind Man.....2 reels

One of the Sharpest, Shrewdest and
Greatest Showmen in the United States

Mr. William Fox

President and largest stockholder in the Greater
New York Film Rental Co.---
President and largest stockholder in the Box
Office Attraction Company---
Sole Owner and director of twenty-seven pros-
perous theatres in New York City and
vicinity---
President and sole owner of the William Fox
Motion Picture Producing Company, is---

The hardest man in this entire country to sell
pictures to, because---
He insists that every photo-play he buys must
conform to---
His high standard of quality which requires---
Absolute perfection in photography, clean
gripping, dramatic stories and---
Intelligent interpretation by competent all-star
casts.

ULTRA-PARTICULAR MR. FOX SELECTED THE
PRODUCTIONS OF THE

Balboa Amusement Producing Co.

In preference to the hundreds of others that competed for the honor for the purpose of branch-
ing out as the operator of a mighty chain of national exchanges. Knowing the temperament
of progressive exhibitors and having a keen understanding of the American amusement-loving
public, he opened important renting agencies in Syracuse, Philadelphia, Pittsburgh, Cleveland,
St. Louis, Kansas City, Dallas, San Francisco, Denver, Minneapolis, Seattle and Chicago with
BALBOA FEATURE FILMS exclusively. He bought control for the United States and
Canada of—

56 Balboa Dramas and Comedies

He has been releasing these photoplay masterpieces in every state in the Union and his ef-
forts have met with unprecedented success. He placed his reliance upon Balboas and Balboas
have paved the way for him to achieve the most remarkable victory in the whole history of
cinematography. In a few short months William Fox has become a famous factor in the mo-
tion picture marts of North America—a giant in picturedom—an international king of the
movies.

MERIT COUNTS EVERY TIME

If You Don't Believe It, Ask Mr. William Fox

Balboa Amusement Producing Company

H. M. HORKHEIMER
Pres. and Gen. Manager

E. D. HORKHEIMER
Sec. and Treasurer

"Makers of the Pictures Beautiful"

Studios and Executive Offices, LONG BEACH, CALIFORNIA

RELEASE DATES FOR READY REFERENCE — Continued

GRANDIN
 12—21. The Adopted Daughter.....3 reels
 1— 4. Cupid Kicks a Goal.....

GAUNTIER
 1— 8. What's in a Name?.....

HUMANOLGY FILM PRODUCING CO.
 12— 7. The Price He Paid, D.....5000
 1—11. Are They Born or Made?.....4 reels

LUNA
 12—17. Rural Romeos, and Finisged St.
 TeaSplit reel

12—24. His Neighbor's Pants, and The
 ChaserSplit reel
 12—31. The Big Stick, and Too Many
 WivesSplit reel
 1— 7. Buy But Baby.....

LARIET
 1— 1. Heart of a Man.....

PREMIER
 12—14. Dr. Killem's Dope.....
 12—19. Hello Girl of Angel Camp.....
 12—22. Her S. O. S. Call.....1 reel
 1— 2. Joe's Retribution

1— 4. The Love Makers.....
 1— 9. An Hour of Horror.....

STARLIGHT
 12—27. Puss in the Well.....
 12—29. The Plumber.....

SUPERBA
 12—13. One on Charlie.....
 12—20. Two Smarties
 12—27. Champeen Detective
 1— 3. Oh, You City Girl, and A Lady in
 DespairSplit reel
 1— 6. Sappho Up to Date.....

FEATURE RELEASES

ALCO FILM CORPORATION

12—23. Tillie's Romance

ALL STAR
 1— 4. Garden of Lies.....

LIFE PHOTO FILM CORPORATION
 12—28. Springtime

1—18. The Avalanche

POPULAR PLAYS AND PLAYERS
 12— 7. The Tigress

1—25. Shadows of a Great City.....

B. A. ROLFE PHOTO PRODUCTIONS
 Nov. Rip Van Winkle.....5 parts
 12—14. The Three of Us.....
 1—11. Satan Sanderson

TIFFANY MOTION PICTURE CORP.
 Heart of Maryland.....

CONTINENTAL FEATURES

KAY BEE
 The Battle of Gettysburg.....

KEYSTONE
 Zu Zu, the Band Leader.....

MAJESTIC
 Ruy Blas

MUTUAL SPECIAL
 Mexican War Pictures.....
 Seeing South America with Roosevelt

NEW MAJESTIC
 Sapho

N. Y. MOTION PICTURE
 The Wrath of the Gods.....

R & M
 The Great Leap.....
 The Gangsters of New York.....
 The Battle of the Sexes.....
 The Floor Above

THE DISHONORED MEDAL
 The Mountain Rat.....
 Home, Sweet Home.....
 The Avenging Conscience.....

THANHOUSER
 Moths

Robin Hood

A Legend of Provence.....

Frou-Frou

Joseph In the Land of Egypt.....
 Cardinal Richelieu's Ward.....
 Dope

PARAMOUNT PICTURES

BOSWORTH
 11—23. The Country Mouse.....4 reels
 12—17. False Colors5 reels
 1—14. It's No Laughing Matter.....4 reels
 2—11. Little Sunset4 reels

COSMOFOTOFILM
 Dec. The Two Columbins.....2 parts
 Dec. A Christmas Carol.....1 reel

FAMOUS PLAYERS
 12—10. The Conspiracy4 reels
 12—14. The Crucible5 reels
 12—21. The Sign of the Cross.....5 reels
 12—28. Cinderella5 reels
 12—31. The Million4 reels
 1—11. The Dancing Girl.....5 reels
 1—18. The Morals of Marcus.....5 reels

JESSE LASKY COMPANY
 12— 7. Ghostbreaker, D.5 parts
 1—21. Young Romance5 reels
 1—25. The Goose Girl.....5 reels

LASKY-BELASCO
 1— 4. The Girl of the Golden West.....5 reels

LASKY-LIEBLER
 1—28. After Five5 reels

ALLIANCE FILMS CORPORATION

COSMOS FEATURE FILM CORPORATION
 Nov. 30. Hearts and Flowers, D.....5 parts

EXCELSIOR FEATURE FILM CO.
 The Path Forbidden.....

11—23. When Fate Leads Trump.....
 In the Shadow.....

FAVORITE PLAYERS
 The Key to Yesterday.....5 parts
 11—16. The Man Who Could Not Lose...
 The Last Chapter.....

MASTERPIECE FILM COMPANY
 11— 9. The Hoosier Schoolmaster.....5 parts
 12—14. The Truth Wagon.....5 parts

OZ FILM COMPANY
 12— 7. The Last Egyptian.....5 parts

SELECT PHOTO-PLAY PRODUCING CO.
 10—26. At the Old Cross Roads, D.....5 parts

COSMOS
 Lena Rivers, D.....5 parts
 The Little Girl That He Forgot, D.....

COSMOFOTOFILM CORPORATION
 Nov. For Home and Country.....2 parts
 Nov. She Stoops to Conquer.....4 parts
 Nov. Called Back4 parts
 Nov. Beauty and the Barge.....4 parts

ECCLECTIC FILM COMPANY
 Week of Dec. 28.
 The Exploits of Elaine, No. 1.....2 reels
 Shot in the Fracas, C.....1 reel
 The Old Thespian, D.....3 reels
 Nick Winter and the Mysterious Bank, C,
 and The Birth of Plants, Ed.....Split reel

Week of Jan. 4.
 The Exploits of Elaine, No. 2.....2 reels
 Romiet Nad Julio, Cart, and Malaga, South-
 ern Spain, Ed.....Split reel
 A Scratch of the Pen, D.....2 reels
 The Price of Tyranny, D.....2 reels

ITALA FILM COMPANY
 Nov. Cabiria4 parts
 Nov. Treasure of the Louzats.....4 parts
 Nov. Jules Porel—Serpent.....3 parts

KINOTOPHOTE CORPORATION
 11— 2. Born Again5 reels
 11—16. The Coming Power.....4 reels
 11—23. The Spirit of the Poppy.....6 reels
 12— 7. The Span of Life.....5 reels
 12—21. The Little Jewess.....4 reels

GEORGE KLEINE ATTRACTIONS
 Spartacus6000
 Lion of Venice.....5000
 European Armies in Action.....3500
 The Naked Truth.....5000
 Julius Caesar6000
 Officer 6665000

BOX OFFICE ATTRACTION CO.

BALBOA
 Criminal Code

Rose of the Alley.....

Test of Manhood.....

Little Sunbeam

The End of the Bridge.....

Little Jack

Message of the Mind.....

The Call of the Heart.....

NEMO
 The Winner

Through Night to Light.....

The Vow

Seeds of Jealousy.....

Bitter Sweets

The Break-Up

WHITE STAR
 Storms of Life.....

The Awakening

The Judge's Wife.....

A Great Secret.....

The Bracelet

The Stranger

To Love and to Hold.....

Vengeance of the Flames.....

BOX OFFICE ATTRACTIONS—Special Features
 11— 9. Life's Shop Window.....
 1—19. The Walls of Jericho.....
 —29. The Thief

SAWYER FILM CORPORATION

AQUILLA
 As a Man Sows.....5 reels

BOSBURN PHOTOPLAY CO.
 Doc, by Eleanor Bates.....4 reels

SANTA BARBARA MOTION PICTURE CO.
 The Envoy Extraordinary.....5 reels
 Thirty Minutes in Melodrama.....2 reels

TRANS-OCEANIC FILMS, LTD.
 Loves and Adventures of Shake-
 speare6 reels

CRAWLEY-MAUDE FEATURES
 Thais4 reels
 The Fatal Night.....4 reels
 Virgin of the Rocks.....4 reels

DARKFEATHER SERIES
 The Skull Worshipers.....2 reels
 Priest or Medicine Man?.....2 reels
 Romance of a Red Princess.....2 reels
 Her College Experience.....2 reels
 Witch of the Sierras.....2 reels

EDYTH TOTTEN FEATURES
 A Factory Magdalen.....5 reels

FLAMINGO FILMS
 Withopt Hope4 reels
 Puritans' Conscience3 reels
 Sybil of the Film.....3 reels

REGENT OF LONDON
 The Wife of a Thief.....3 reels

CO-OPERATIVE CO.
 The Lady of Lyons.....4 reels

JAPANESE AMERICAN FILM CO.
 Oath of the Sword.....3 reels

CECIL FEATURES
 Cecil Spooner, in Nell of the Circus..4 reels

PHOENIX FILM CO.
 Spirit of the Conqueror.....5 reels

LIBERTY FILM CO.
 Hearts United4 reels
 Hero of the North.....2 reels

INDIAN PICTURE MAKES BIG HIT

"IN the Land of the Headhunters," Edward S. Curtis's wonderful Indian picture, is drawing increasing crowds at the Montauk Theatre, Brooklyn. The production had this same successful experience at the Casino Theatre, New York, even during a week when it rained almost unceasingly for four days.

In the opinion of the Casino management and other astute observers "In the Land of the Headhunters" is so proven a Broadway "hit" that it is good for a run of several months on the great thoroughfare.

Arrangments have therefore been made to bring the picture to Broadway after the Brooklyn run, which will last through the holidays.



THE WAR CANOE OF THE TRIBE

The Western Company opened at Seattle last week and is playing to crowded houses.

"In the Land of the Headhunters" ranks as one of the great pictures of the year. It took Mr. Curtis two years to complete the production and an expenditure of \$75,000. Its success is well deserved.

NEW REVIEWING COMPANY IN THE FIELD

WITH the advent of the newly incorporated Motion Picture Reviewing and Reporting Company, the moving picture field is gaining an institution for which there has been a demand of long time standing. With reliable and unbiased reports and criticisms, which the new organization promises to furnish at a nominal fee, the exhibitor, subscribing to the service, will save for himself much time, trouble and expense heretofore experienced in looking up reports and attending screenings. The company has at its head as directors Messrs. H. J. Brock, M. B. Schlesinger and M. S. Epstein, all well known in the picture world. The criticisms will without question be honest and unbiased. A staff of experienced film men, with the individual exhibitor's requirements

in mind, will review the pictures for the subscribers and the company will send out a batch of reports on the various releases each week. It also intends to furnish confidential special reports to exhibitors.

M. B. Schlesinger, who is the general manager of the company, is also the special New York representative of the United Motion Pictures Company of Buffalo, and the All Feature Company of Canada, in which capacity he reports on and buys all the feature pictures for the various theatres and exchanges of these concerns.

The new company has taken a suite of offices in the Putnam building, 1495 Broadway. Among its first clients are the following: The New Academy and Regent Theatre, Buffalo; the Imperial, Francais and Family theatres, Ottawa, Canada; the Family, the Scala and Francais theatres, Montreal, and the Strand and York theatres in Toronto.

FIRST LARIAT RELEASED DECEMBER 28

THE first Lariat picture, "The Heart of a Man," is scheduled for distribution by the United Film Service, December 28.

The Pike's Peak Film Producing Company, the originator of the new brand, has just begun operations at Colorado Springs, and "The Heart of a Man" represents the first production of the company.

Hector A. Cobb, who portrayed the part of "Curley" Smith in "Across the Border," a notable western film issued some time ago by Warner's Features, Inc., assumes the leading male role in "The Heart of a Man."

George Gebhart, who has been engaged as assistant director and leading man of the new organization, will devote his time between directing and acting. He was not cast in the first Pike's Peak picture for the reason that the multitudinous details connected with launching the new organization monopolized his time. He will, however, appear in the second release. Josephine West is the heroine.

The Pike's Peak Film Producing Company is the most recent addition to the organization comprising the United Motion Picture Producers, Inc.

The company will in all probability bring out many novel pictures.

LASKY ANNOUNCES CASTS OF "YOUNG ROMANCE," AND "GOOSE GIRL"

SAMUEL GOLDFISH announces the following complete casts for the Jesse Lasky productions of "Young Romance," which is to be released on January 21, and "The Goose Girl," which will be released on January 25. The star of "Young Romance" is Edith Taliaferro, and the supporting company includes Tom Forman, Frederick Wilson, Ernest Garcia, Marshall Mackay, Harry de Vere, Parke Jones, Charles Wells, Florence Dagmar, Violet Drew, Mrs. Lewis McCord, Miss Kellar, Miss Abril and Miss White.

Miss Marguerite Clark, by the courtesy of the Famous Players Film Company, assumes the stellar role in "The Goose Girl." The other leading artists in the company are: Monroe Salisbury, Sidney Dean, E. N. Dunbar, James Neill, L. Bayton, B. E. Peters, H. B. C. Carpenter, Ernest Joy, J. M. Cassidy, Miss Johnson and Jane Darwell.

FAVORITE PLAYERS FILM COMPANY

PRESENT

"THE MAN WHO COULD NOT LOSE"

A Five Part Photo Play From the Book By
RICHARD HARDING DAVIS

Previously Released
THE KEY TO YESTERDAY

Executive Offices:
110 W. 40th St., N. Y. C.

Released Through The
ALLIANCE FILM CORP.

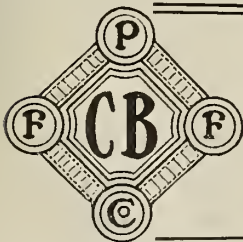

BOOK
**WHEN
FATE
LEADS
TRUMP**
(Four Parts)

EXCELSIOR

FEATURE FILM COMPANY, INC.

110 WEST 40th STREET, NEW YORK CITY

BOOK
**THE PATH
FORBIDDEN**
**ALLIANCE
PROGRAM**

INTERESTING FILM REVIEWS

(Continued from page 50.)

"Sid Nee's Finish." (Thanouser. Sun., Dec. 20.)—Sidney Bracy's first reappearance on the screen after his work in "The Million Dollar Mystery" is marked by a comedy part. Mr. Bracy also wrote the scenario for the picture and appears as a Chinese laundryman, the title part. The picture, although not uproariously funny, will afford fair entertainment. Sid Nee has opposition in the laundry business in the form of a daughter of old Ireland, who finally triumphs over him, mostly by means of force. Mr. Bracy is by all means the best actor in the picture, but the supporting cast is quite competent. The photography is fair.

"Under False Colors." (Thanouser. Two reels. Tues., Dec. 22.)—While this picture is not tiring in the least, it hardly warrants the space of two reels. The photography and acting are both good. Flo La Badie, who plays the principal part, has one scene in which she tries on a number of gowns, which will be more than likely to appeal to the feminine part of the audience. The story is that of a young girl who goes to the city as the protegee of a society girl. She is introduced as a Princess, and immediately the other girl's fiance deserts her for the supposed Princess. This so angers the girl that she tells everyone Flo's real identity, but afterward apologizes. But the country girl has had enough of city life, and returns to the country and her true lover.

"Tin Can Shack." (American. Wed., Dec. 23.)—An old man abducts his grandchild because of harsh treatment by his daughter. For fifteen years they live in happiness in a little shack in the mountains. Then a young hunter comes along and breaks through the old man's reserve by saving his life when the shack is destroyed by fire. The girl and the old man go home with the young fellow as an ardent and favored suitor for the granddaughter. John Stepping and Winnifred Greenwood are seen as the grandfather and granddaughter.

"The Fear of His Past." (Majestic. Two reels. Mon., Dec. 20.)—An adventure lands a man in jail for a theft which she committed. He escapes and is well established as the private secretary of a wealthy old colonel when the same woman appears and makes him help her in trying to rob his employer by threatening to give him up to the police. Fortunately the colonel and his daughter, who is the secretary's sweetheart, overhear a quarrel between the adventurer and her victim in which the woman admits her guilt. The result is a pardon from the governor for the secretary and jail for the woman. Mary Alden is seen as the adventurer, while Spottiswoode Aitken gives a most excellent portrayal of the old army officer.

"A Lucky Disappointment." (Reliance. Wed., Dec. 23.)—An elopement is in vain because the only parson in the region is away. After agreeing to try again the next day the lovers return to the girl's home. There two men have captured the girl's father, who is portrayed by Baldy Belmont, and are about to torture him to find out the combination of the safe. The lover captures them and thus wins such favor that an elopement is unnecessary.

"A Hat Full of Trouble." (Thanouser. Sun., Dec. 27.)—Frank Farrington, late of "The Million Dollar Mystery," plays a comedy part in this offering, departing largely from his heavy lead in the late serial. As a "drunk," Mr. Farrington plays the part without being the least offensive; instead, he is exceptionally funny, as too, are the situations that appear throughout the reel. One especially funny and quite novel scene is that in which the man comes home, with a good bit inside, and attempts to retire. His room, by an ingenious device used by the property man, spins round and round. The whole picture is really funny from start to finish and will be well appreciated.

"The Face on the Ceiling." (Broncho. Two reels. Wed., Dec. 30.)—The last scene in this picture, from which it draws its name, is perhaps the only unusually far fetched one in the entire offering. A crook climbing through a trap door in the roof of a house is caught by his coat, and there he stays, supposedly until he dies. The story concerns a girl whose father is a crook, who manages to break away from her old life after she has fallen in love with a detective who has rounded up the band by posing as a member. Her father attempts to kill her husband but is killed himself in the manner already described. Although an old theme is taken as the main plot, the situations that have been brought out by the director are new and always tense. Walter Edwards plays the part of the master crook, and he also produced the picture. Arthur Maude plays the hero in a convincing style. The rest of

the cast is equally good. The photography is good and the scenes are well chosen.

"The Deadly Spark." (Kay-Bee. Two reels. Fri., Jan. 1.)—Great suspense is evidenced in this picture as the spectacle of the deadly live wire laid as a trap for crooks is forcibly productive of such a property. The daughter of a rich family, marries a man, against her father's wishes, who turns out to be a gambler. From gambler the husband turns to crook, but he meets his death when he attempts to rob his father-in-law's house. Later father and daughter are reconciled. This is a very pleasing offering, wonderfully well constructed as are all of Mr. Ince's pictures. It is interesting in its entirety, and acted well.

"Putting It Over." (Royal. Sat., Jan. 2.)—A young chap, in order to marry his girl against her father's wishes, supplies her with some of his clothes while she does the same for him. That night they run off disguised in each other's clothes. The father chases them, but arrives just as the minister, who has been routed out of bed, has finished the ceremony. He is so pleased over their trick that he forgives them at once. A fair comedy.

WEEKLIES

"Hearst-Selig News Pictorial, No. 83." (Selig. Mon., Dec. 14.)—Scenes on the sugar plantations near Braithwaite, La.; Thomas Mott Osborne on becoming warden of Sing Sing prison, N. Y., poses for the camera; annual scrap between freshmen and sophomores of Rensselaer Polytechnic Institute, Troy, N. Y., for the supremacy of the Watervliet reservoir; Pueblo Indian village reproduced for the San Diego exposition; the sporting leaders of London, form battalion and depart for war; Walter Maranville and his bride visit George Tyler at his farm (both men are members of the World's Champion Boston Braves); gathering firs and evergreens for Christmas.

"Universal Animated Weekly, No. 145." (Wed., Dec. 16.)—The European war occupies an exceptionally prominent place in this number as eight of the twelve topics concern this subject either directly or indirectly. The dire havoc wrought by the violent wind storm which recently swept the Atlantic coast is vividly depicted on the screen, one scene shows Scabright, N. J., at the height of the fury. Two other domestic items and the renowned cartoons by Hy Mayer complete this interesting weekly.

"Hearst-Selig News Pictorial, No. 84."—This reel offers news pictures of a wide variety. Not many views connected with the war are shown, but such as do appear are of much interest. Several of the German vessels engaged in the recent naval battle off the Falkland Islands are shown. Scenes of unusually striking nature are those showing the damage being done by the recent heavy storm along the Atlantic coast.

"Hearst-Selig News Pictorial, No. 85."—Only two views connected with the European war are in this reel. These show the arrival of the Santa Claus ship *Jason* in England and the children of the King of Belgium in London. The burning of the Edison plant at West Orange and the painting of Brooklyn Bridge are two of the interesting pictures taken in this vicinity.

"Mutual Weekly, No. 104."—About half a dozen interesting war scenes appear on this reel, some of them showing more of the ruin caused by shells. Views of two train wrecks and of two bad fires, one being at the Edison plant in West Orange, are given. A game of winter baseball, the sport of the New York clubs, is depicted. The Screen Club ball at San Francisco is shown in all its glory, with Mutual stars in the limelight.

UNITED SERVICE

"The Eye of Justice." (Features-Ideal. Two reels.)—This picture portrays the dire calamities that befall a man who was wrongly accused of robbery. In the end he is vindicated. Several new situations have been brought in this rather old story, and altogether it is an interesting offering. At first the plot seems rather tangled, due to the fact that the film has been cut. The acting is of a high class throughout, and the photography is better than the average. As the picture was made abroad, and as the principals of the cast, the scenes, sets and the whole atmosphere scents of the foreign, it seems rather foolish to name one of the cities New York, but this may be corrected.

"Hoboes." (Starlight.)—There are three of them in number, and they are dressed rather grotesquely and are even repelling at times. A story of rivals in love is also combined with the

antics of the titular characters which would stand a fair chance of being funny if the actors were not dirty and almost inhuman at times. The close-up of one tramp rubbing his brother's face in a piece of pie ought to be omitted.

"The Plumber." (Starlight.)—There is a good plot to this, but there will not be many laughs as again the actors are too dirty. Two plumbers conceive the brilliant idea of damaging some pipes so that they can find work. They do so, but the townspeople get wise and flood the plumbers' house at night.

"Reginald's Revenge." (Premier.)—This film concerns the actions of two effeminate appearing men, for the most part, and another line depicts the efforts of a woman detective to find a young girl's dog, which, it is thought, has strayed into the hands of a "hot dog" vender. However, the dog happens to be still alive, and its mistress consents to marry her true lover after she has cast off Reginald. This will afford fair entertainment.

"Decree of Destiny." (Premier.)—A story telling the life of a beggar who after his child has been adopted becomes immensely wealthy and afterwards is reunited with his daughter. The trouble with the picture is that practically no climax puts in an appearance. The interest aroused by the story is not very great. Joe Franz is the leading man.

"Cupid Kicks a Goal." (Grandin.)—The daughter of a college professor loves a football star, but father does not agree. When he learns that the two intend to elope he dresses another boy as his daughter, but the deception is discovered and the joke turns out to be on the professor. Ethel Grandin has a suitable part as the daughter. This picture is a clean and laughable comedy-drama, mostly comedy, that will be enjoyed. Aside from the fact that more than six usually attend a college football game the atmosphere is good. The settings and photography are excellent.

"The Big Stick." (Luna. Split reel.)—A very humorous half reel, showing how a sailor tried to get rid of his rival by sending him away on a ship, but instead he gets his prospective father-in-law. Father gets free however, and the schemer is captured himself. The most humorous part of this comedy are the scenes in which a gigantic man in an effort to procure sailors for his ship, smites them all on the head with a club. This is shown on the same reel with "Too Many Wives."

"Too Many Wives." (Luna. Split reel.)—This comedy appears on the same reel with "The Big Stick" and is almost its equal in funmaking qualities. Just for convenience a vaudeville performer changes clothes with a man who is trying to get away from two angry women, both claiming to be his wife. Due to his kindness the actor gets what was coming to the other man, which isn't very pleasant.

"What's in a Name." (Gaugmont.)—An engaging farce in which the youthful offspring manages to beat his father out by marrying the girl the older man had already selected as his second wife. Played in a capable manner. The photography is good.

"The Lash of Fate." (Features Ideal.)—Of foreign make and containing excellent photography and well chosen scenes. Accused by a jealous woman of murder, Percy makes good his escape aided by an old man and his daughter. After this Percy recedes for a while and the young girl marries and lives happily with a blacksmith, until Percy enters once more. Seeing his wife with Percy, the blacksmith becomes jealous, and after attempting to kill him, flees. Later the blacksmith himself dies, and the conclusion is left to the imagination.

"HALF THE EXHIBITORS DON'T KNOW WHAT THE OTHER HALF IS DOING"

was true—

BEFORE "MOTION PICTURE NEWS" CAME.

Scenarios Wanted

WANTED, first class scenarios for comedies and dramas.

Address:

GAUMONT CO. SCENARIO DEPT.
CONGRESS AVENUE
FLUSHING, L. I., N. Y.

WE SEE THEM ALL

WE SEE THEM ALL

To Every Exhibitor in the World

THE MOTION PICTURE REVIEWING & REPORTING CO., Inc.

H. J. BROCK, Director

M. B. SCHLESINGER, General Manager

M. S. EPSTIN, Director

SUITE 432-434

1495 BROADWAY

NEW YORK CITY

Phone, 7695 Bryant

IS NOW AT YOUR SERVICE

With Honest, Unbiased and to Be Depended on Reports and Criticisms of All Feature Film Releases

Special Confidential Daily and Weekly Reports Furnished

AT A TRIFLING COST TO YOU!!

POOR PICTURES MEAN POOR BUSINESS!!

OUR SERVICE PREVENTS THIS

BE A SUBSCRIBER AND SAVE TIME, TROUBLE AND EXPENSE
WRITE OR WIRE FOR COMPLETE DETAILS

MOTION PICTURE REVIEWING & REPORTING CO., Inc.

1495 Broadway, New York City

WE SEE THEM ALL

WE SEE THEM ALL

REFERENCES: MARK-BROCK THEATRICAL ENTERPRISES
BUFFALO, N. Y.
THE WORLD'S LARGEST PICTURE EXHIBITORS

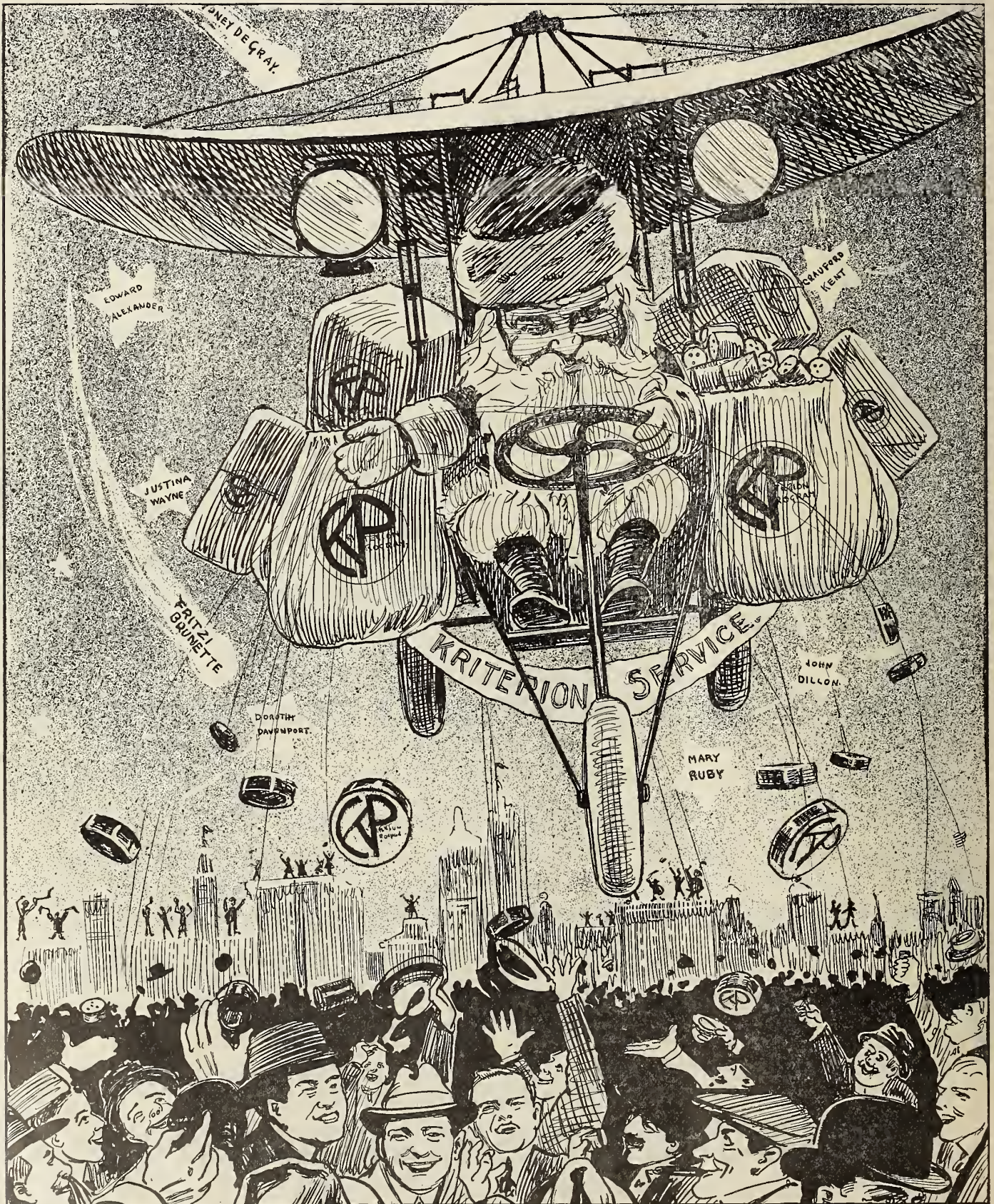



Resolved

THAT—

We give good stories in all our films.

Employ the best directors for each of our companies to picturize these stories.

Have the best photography obtainable in all the reels.

Our special subjects will equal or surpass other five or six reel features.

Our comedies shall attain the highest standard at all times.

We give direct co-operation to our Exhibitors.

Any criticism or complaints from Exhibitors will be adjusted through our main office.

We have quality throughout our whole service.

We believe we are right when we say—"You can fool some of the people all of the time and all of the people some of the time, but you can't fool all of the people all of the time."

And

Kriterion Service will be "Decidedly Distinctive" by pleasing all of the people all of the time.

Kriterion Service
1600 Broadway
New York City

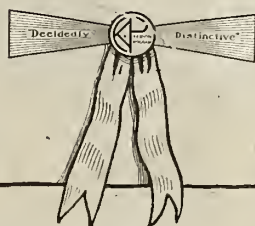

VITAGRAPH

"THE PRODUCT" Drama Monday, Dec. 28th
It produces wealth for one man, misery for another. By giving it up both acquire happiness. MAURICE COSTELLO in the lead.

"THE PLOT" Drama in Two Parts Tuesday, Dec. 29th
An assassin hypnotizes a young man. He attempts to kill his intended's father. Love breaks the spell. Joy prevails. MAURICE COSTELLO is the principal.

"FORCING DAD'S CONSENT" Comedy Wednesday, Dec. 30th
Dad goes to the caharet instead of the missionary society. Billy meets him there. His consent to Billy's marriage to Constance is the answer. BILLY QUIEK as Billy.

"LOVE WILL OUT" Comedy-Drama Thursday, Dec. 31st
He revels in the ideal. His sweetheart is practical. Her stronger counsel brings him courage and success. It brings joy to both. MARGARET GIBSON and a star cast.

"AUNTIE'S PORTRAIT" Comedy Friday, Jan. 1
Her nephew and his wife don't want it, but they want her money. After many funny complications they get both. SIDNEY DREW as the nephew.

"IN THE LATIN QUARTER" Drama in Two Parts Saturday, Jan. 2
The blow intended for his rival strikes down the woman he loves. Her life is spared. He confesses his jealousy and his error and all is forgiven and forgotten in their happiness. EDITH STOREY, ANTONIO MORENO, S. RANKIN DRBW and CONSTANCE TALMADGE are the cast.

SIX A WEEK
"FLORA FOURFLUSH" (Treachery In The Clouds)—Comedy. MONDAY, JAN. 4
"TWO WOMEN"—Drama in Three Parts. TUESDAY, JAN. 5
"BILLY'S WAGER"—Comedy WEDNESDAY, JAN. 6
"THE MAN, THE MISSION AND THE MAID"—Comedy-Drama. THURSDAY, JAN. 7
"THE SMOKING OUT OF BELLA BUTTS"—Comedy. FRIDAY, JAN. 8
"A DAUGHTER OF ISRAEL"—Drama in Two Parts. SATURDAY, JAN. 9

VITAGRAPH ONE, THREE AND SIX SHEET POSTERS
The Vitagraph Company of America
East 15th Street and Locust Avenue, Brooklyn, N. Y.

BROADWAY STAR FEATURES

LISTED AND RELEASED

A Million Bid	5 Parts	A Florida Enchantment	5 Parts
Goodness Gracious	3 Parts	413	3 Parts
Mr. Barnes of N. Y.	6 Parts	The Win(k)some Widow	4 Parts
Love, Luck and Gasolene	3 Parts	The Tangle	4 Parts
Captain Alvarez	6 Parts	The Locked Door	3 Parts
Shadows of the Past	3 Parts	Sylvia Gray	4 Parts
Mr. Bingles' Melodrama	3 Parts	The Little Angel of	
My Official Wife	5 Parts	Canyon Creek	5 Parts
Uncle Bill	3 Parts	Two Women	3 Parts
The Painted World	3 Parts	The Sage Brush Gal	3 Parts

COMING FEATURES

4-Part Comedy THE MAN BEHIND THE DOOR From A. C. Gunter's Story	3-Part Drama UNDERNEATH THE PAINT With Helen Gardner and Strong Cast
4-Part Comedy C. O. D. A Wonderful Screen Version of Frederick Chapin's Laughing Story	4-Part Comedy HOW CISSY MADE GOOD With Cissy Fitz-gerald, Flora Finch and Entire Stock Company
	5-Part Drama THE SINS OF THE MOTHERS \$1,000 Sun Scenario Contest Winner

For terms and particulars apply
GENERAL FILM COMPANY'S SPECIAL SERVICE
By Arrangement With BROADWAY STAR FEATURE CO., (Inc)

LUBIN

LUBIN MASTERPIECES—THE PERFECTION OF PHOTO MOTION
Ready and About To Be Released
(Through the General Film Company)

EDWIN ARDEN

Drama Direction—
By Edwin Arden Romaine Fielding
IN **"EAGLE'S NEST"**

"THE DISTRICT ATTORNEY"

Drama Direction—
By Charles Klein Borrry O'Neil

"THE WHITE MASK"

Drama Direction—
By Cloy M. Greene Joseph W. Smiley
FEATURING LILIE LESLIE

ROSE COGHLAN

And ETHEL CLAYTON in
"THE SPORTING DUCHESS"
Comedy Drama Direction—
By Cecil Roleigh Barry O'Neil

"THE COLLEGE WIDOW"

Featuring Ethel Clayton and George Soule Spencer
Comedy Drama Direction—
By George Ade Barry O'Neil

"THE VALLEY OF LOST HOPE"

Drama Direction—
By Shannon Fife Romaine Fielding

NOW SHOWING TO CROWDED HOUSES (By Arrangement with Fred Mace)

EVELYN NESBIT THAW and her son **RUSSELL WILLIAM THAW** in **"THREADS OF DESTINY"**
Drama Direction—
By William H. Clifford Joseph W. Smiley

SIX REGULAR RELEASES EACH WEEK

SPECIAL ONE, THREE AND SIX SHEETS



"PATSY BOLIVAR," First of Series, "Patsy at School" Comedy.....	Monday,	December 28th
"A COWBOY PASTIME"—Comedy.....	Tuesday,	December 29th
"THE INTRIGUERS"—Two Reel Drama.....	Wednesday,	December 30th
"FATE AND THE FUGITIVE"—Two Reel Drama.....	Thursday,	December 31st
"A CLEAN SLATE"—Drama.....	Friday,	January 1st
"HE GAVE HIM A MILLION" Split Reel Comedies.....	Saturday,	January 2nd
"WHAT HE FORGOT"		

Lubin Manufacturing Company, Philadelphia, Pa.

Chicago Office: 154 West Lake Street



VITAGRAPH

All 3-Part Broadway Star Features

By Special Arrangement with the Broadway Star Feature Co.

**WILL BE RELEASED IN THE REGULAR GENERAL FILM SERVICE
EVERY ALTERNATE TUESDAY and EVERY ALTERNATE SATURDAY**

(Replacing Two-Part Releases formerly listed on these days.)

THE FIRST WILL BE

“TWO WOMEN”

RELEASED TUESDAY, JANUARY 5TH

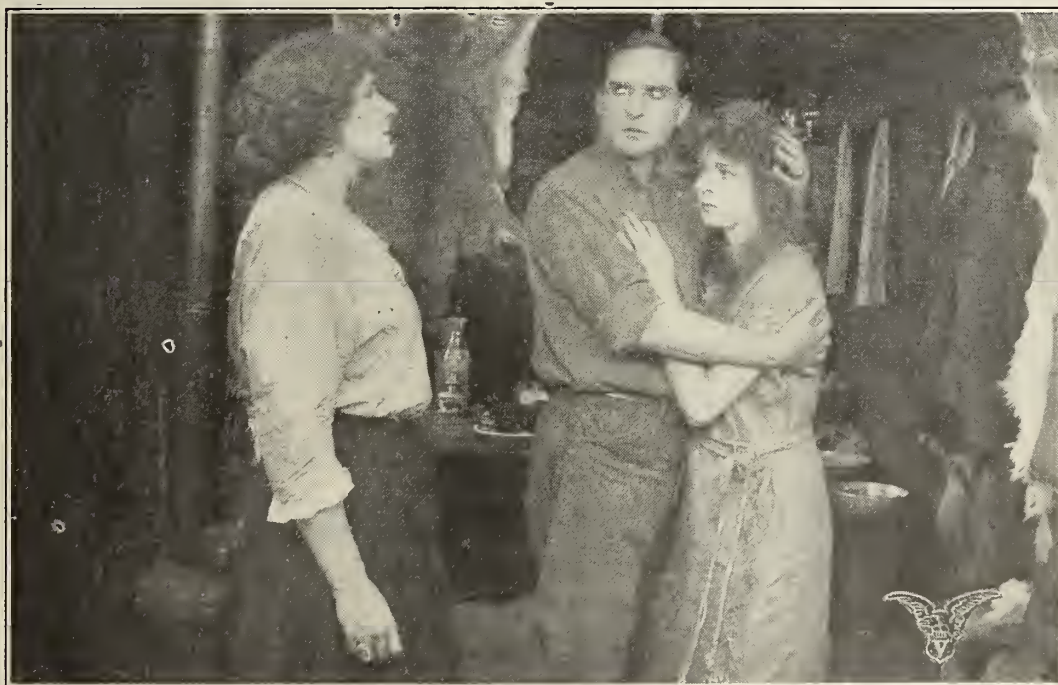

“Such plays are an unusual occurrence.”—Dramatic Mirror
“The Soul Adventures of Two Women.”—New York American

“A Powerful Drama of Life.”—Telegram
“A Virile Drama.”—Evening Sun

IT HAS MADE GOOD
AT THE VITAGRAPH THEATRE
IT WILL MAKE GOOD
AT YOURS

IF YOU ARE LOOKING FOR THE GOODS

BOOK The Alternate Tuesday and Saturday
Broadway Star Features



Quality

First!

600 LIVE NEWSPAPERS

and half a million dollars spent in advertising in those papers—your own local newspaper included, Mr. Exhibitor—will drive the people into your theatre and the

STANDARD PROGRAM

will keep 'em there day after day and week after week.

STANDARD PROGRAM

means exactly what it spells—a program of superlative quality—clean, wholesome, interesting, instructive and amusing pictures—pictures with the suggestive, the innuendo, the crime for crime's sake all cut out and the punch put in and fastened there by the best producers in the employ of the keenest manufacturers, with QUALITY FIRST, LAST AND ALL THE TIME!

MAKE YOUR ARRANGEMENTS NOW FOR THE
STANDARD PROGRAM

TO BEGIN JANUARY 18, 1915

STANDARD POLYSCOPE CORPORATION

WM. P. COOPER, President

H. C. HOAGLAND, Gen'l M'g'r.

115 BROADWAY

NEW YORK CITY

FOR INFORMATION REGARDING THIS NEW SERVICE
WRITE THE STANDARD PROGRAM ASSOCIATION

JOSEPH HOPP, Pres.
164 W. Washington St.
Chicago, Ill.

NELSON F. EVANS, Vice-Pres. D. S. MARKOWITZ, Vice-Pres.
Commercial Bldg. California Film Ex.
Cleveland, Ohio. Los Angeles, Cal.

SAM'L WERNER, Treas., 14 N. Ninth St., E. T. PETER, Secy., Dallas Film Corporation,
St. Louis, Mo. Dallas, Texas.

TERRISS BEGINS "A MAN'S SHADOW"

Tom Terriss, who is putting on the famous Terriss plays for the Kinetophote, has picked his cast for the first of this series of plays. He has chosen for the first of these pictures "A Man's Shadow," one of the pieces which was made famous by William Terriss at the Adelphi Theatre in London.

As has been announced, Mr. Terriss will have for his leading woman Anna



RIENZE DE CORDOVA

Luther, who has been starred for some time in the Lubin pictures. For the Viscount Acheson of the story he will have Lionel Pape. Rienze de Cordova is the Craig Dare of the piece. Mr. de Cordova has played in America for years, having been under the Frohman management, where he appeared with Richard Mansfield, Henry Miller and Maude Adams. In pictures he has done heavy leads for Kalem, the Famous Players and the Vitagraph.

Among others in the cast are Alfred Heming, Alfred Palmer, Walter Kingsford, William Lewin, Cornish Beck, Katheryn Adams, Millie Liston and not to forget Millie Terris, who is the joy and pride of the household of Mr. and Mrs. Tom Terriss. Work on "A Man's Shadow" was begun last week.

FIRST BABY BORN IN UNIVERSAL CITY

Universal City is all excitement for in the early hours of December 21 a baby boy was born within its limits, the first child of either sex to have its name inscribed on the birth register of the infant city. The boy, Carl Bernie Oelze, is the son of Mr. and Mrs. Charles Oelze, the commander of the "U" cowboys.

Mrs. Oelze before her marriage was a nurse in Universal Hospital. According to latest reports she is doing nicely and was not at all affected by the fervor of the demonstration in honor of her first born.

HERRINGTON SUCCEEDS WITH SUNDAY OPENING

Fred J. Herrington, owner of the Coliseum Theatre at Mt. Oliver, a suburb of Pittsburgh, has had his theatre open the last two Sundays. No set price of admission is charged but a silver offering has been taken up at the door. So far the borough or county authorities have not molested him, and he states he will continue the keeping of the theatre open until he is closed by one or the other of the branches of the law in this section. He states that business is not very good as the people in that section seem to be timid about attending Sunday shows.

"STOP THIEF," KLEINE COMEDY, COMPLETED

George Kleine's "Stop Thief," by Carlton Moore, founded on the famous comedy which had such a successful run under the management of George M. Cohan and Sam H. Harris, has been completed at the Kleine studios.

Harry Mestayer, who plays the male lead of the thief, arranged to leave New York immediately after his work had been finished to open an engagement at the Grand Opera House, Chicago, in the latest Cohan and Harris success, "On Trial."

LOW RENT FOR FILM FIRMS

The troubles which have arisen in regard to New York fire regulations have caused inconvenience to many of the motion picture companies with the result that numerous of them are looking for new quarters.

One of the buildings available for this purpose is the Masonic Building, 71 West Twenty-third street, New York, in which room can be had at a remarkably low figure. The reason for the trouble in connection with the other buildings is the fact that they are located inside the proscribed distance from schools and theatres or other public resorts.

LORIMORE WILL BOOK BOY SCOUT PICTURE

Alec Lorimore announces that he has made arrangements to handle an extensive campaign for booking the Boy Scout picture.

The Boy Scout movement in this country is upwards of four hundred and fifty thousand boys. The membership will possibly be doubled before Alec Lorimore is through with the bookings of this drama by Campbell MacCulough. President Wilson has taken part and the endorsement of Theodore Roosevelt, Judge Ben Lindsey, Gifford Pinchot and others has been obtained for the picture.

WALL TO OPEN PERCENTAGE EXCHANGE IN BIRMINGHAM

Alex Wall, well known as an exhibitor in the South, has opened an exchange in Birmingham, Ala., and will handle features on a percentage basis. Officers are now being fitted up, and Mr. Wall is desirous of communicating with producing companies in the North and in the West. A letter addressed to Box 553, Birmingham, Ala., will reach Mr. Wall.



LEA LELAND
(Ivan Film Productions)

BERGH IN CHARGE OF SCENARIO AGENCY

Albert Ellery Bergh, of the Biograph scenario staff, has accepted an offer to take charge of the scenario department of the Baermann Literary Agency, at 225 Fifth avenue, New York.

Mr. Bergh, however, will continue to write scenarios and act as an editorial scout for the Biograph company during its winter sojourn at Los Angeles.

EDWARD JOSÉ IN "A FOOL THERE WAS"

Edward José plays the lead in "A Fool There Was," the drama in which Robert



EDWARD JOSÉ

Hilliard made a tremendous hit on Broadway some time ago.

The film version is released through Box Office Attractions and promises in every way to equal its famous footlight original.

"THE BLACK SPOT"

(Cosmofotofilm—Four Reels)

REVIEWED BY CLIFFORD H. PANGBURN

SELDOM does one have an opportunity to view a four-reel picture so perfect in structure as this drama of Russian political life. Nor is perfection of structure its only bid for fame. It is a story which is literally gripping, it has many fine light and scenic effects, and besides this it is acted with a skill which borders on perfection. All this may seem high praise, but it is no more than the production deserves. George Tucker, who directed the picture for the London Film Company, has done in it the best work yet to his credit.

All the scenes in the first reel are laid in Russia, and include many midwinter night views about the house of the aged Professor Scerloff. These are necessarily studio work, but they are unusually fine examples of the artificial creation of snow effects, while careful lighting arrangements have resulted in realistic backgrounds. The action, which takes place in England, is not so difficult to depict, but some excellent photography is seen.

Jane Gail, in the role of Olga, the professor's daughter, plays a part which is heavily dramatic throughout the entire film, but she appears to even more advantage than in some of her other successes. Charles Rock is seen as the old professor, a role which he handles convincingly. A. Holmes-Gore appears as the kind-hearted and plucky Grand Duke Paul, with Gerald Ames as Captain Drouky, his aide, and Frank Stanmore as his secretary.

The story opens in Russia, where a little band of students are attending secret meetings at the home of the aged Professor Scerloff. There is not any thought of violent acts on the part of the group, but rather serious educational work for the betterment of conditions in Europe. Nevertheless the place is raided, and the professor's wife is killed by the shock of seeing him beaten and her daughter handled roughly.

The Grand Duke Paul, who happens to be passing, comes into the house and gives orders that banishment instead of a sentence in Siberia be their punishment. The professor and his daughter suppose the Duke to have been responsible for all their trouble. Later they are in England, where they attend meetings of Russian exiles. The Grand Duke Paul comes to England on a visit. He is interested in helping to advance political reforms, and therefore obtains entrance to the circle of plotters in disguise.

There he hears the council vote to kill him, and sees Olga draw the black spot, which means that she is to do the work. He has her introduced to his house as a stenographer, and by giving her certain papers to copy shows her how much he is helping her cause. He thus influences her so that she will not kill him. When her so-called treachery is learned by the other Russians they again draw lots, and the Grand Duke by a trick is the one picked to kill Olga.

Needless to say he avoids doing this, although at the risk of his own life. The first reel is surprisingly strong, but the other three are up to the pace it sets, and the picture is in every way an excellent one.

SMALLWOOD OPERATES OWN CAMERA

TO Ray C. Smallwood falls the distinction of being one of the few directors in the motion picture industry who operate their own cameras. Not satisfied with this two-in-one combination, he insists upon driving his own automobile while making exteriors, writes most of his own stories, supervises the work of the factory, cuts up his own negatives and takes care of the other work that falls to his lot as vice-president and secretary of the Smallwood Film Corporation.

At the present writing, he has only to perfect a motor attachment to run his camera in order that he may equip himself to work in the pictures with Ethel Grandin, whose work he is directing.

QUAKER CITY REEL FELLOWS PLAN FESTIVITIES

Special to MOTION PICTURE NEWS

Philadelphia, Dec. 15.

THE Reel Fellows Club have a big entertainment in prospect. Stanley Mustbaum, of the Stanley company, and C. L. Peny, manager of the Globe theatre, have the affair in hand and some big surprises can be looked for. The Reel Fellows are about to close their charter, membership having brought the number up to the limit set.

FLAMINGO COMEDIES GET A SUCCESSFUL START

ON Sunday night, December 20, the first of the Flamingo Comedies was shown for public exhibition to a crowded audience at the Olympia Theatre, Broadway and 107th street, New York City.

"Without Hope" was the first production decided upon from the prize-winning scenarios of *The Morning Telegraph* and Chartered Theatres Corporation National competitive contest, and was a picturization of the work of Elaine Sterne who has won many prizes recently for stories and scenarios. Among the photo-play stars who made the production under the direction of Fred Mace were Margaret Loveridge, Catherine Proctor and Mary Charleson.

The picture was greeted with enthusiasm. Bookings from all over the country are being received through the Zone offices of the Sawyer Film Corporation.

This and all the Sawyer features are booked for Greater New York and New Jersey by the Colossus Film Co., 110 W. 40th street.

PETER, AMERICAN CANINE ASSISTANT, BACK AT STUDIO

"PETER THE GREAT," a dog well known in the Mutual program, has been found. The American's brindle bulldog is once more safe in the studios. It was a dark hour when the canine favorite of Margarita Fischer and beloved pal of little Kath Fischer disappeared.

For several days no traces of him could be discovered—and then someone phoned Harry Pollard that he had been seen in Garden street, Santa Barbara. Of course they knew it was Peter from being familiar with his distinguished likeness on the screen.

Mr. Pollard, knowing that the dog would recognize the car, had his chauffeur drive around to Garden street. The chauffeur was going along at an easy pace, when, glancing over his shoulder, he saw with joy that the expected had happened. Peter was comfortably seated in the tonneau, looking only too glad to be going home.

CHANGE OF CENSORS IN SPOKANE PLEASES EXHIBITORS

Special to MOTION PICTURE NEWS

Spokane, Wash., Dec. 21.

FEWER "bans" and freak rules for theatre managers are expected since the departure of the Rev. W. J. Hindley, former mayor and official censor, from Spokane.

The city council has appointed Commissioner of Public Affairs Samuel Glasgow to the censorship post and he has entered upon its duties.

Mr. Glasgow has never been a devotee of the theatre, but expects to become a much more regular attendant hereafter. His policy, however, will be to leave much more to the personal discretion of the managers than did his reverend predecessor.

YOU CAN'T FAIL

to find what you want in

**Motion
Picture
News**

because

MOTION PICTURE NEWS IS
MADE TO MEET EVERY ONE
OF YOUR WANTS BY
MEN WHO KNOW
WHAT YOUR
WANTS
ARE.

RELEASE NOV. 23rd

DIGBY BELL

in

**THE EDUCATION
OF MR. PIPP**

(5 Parts)

—DECEMBER 28th—

JANE COWL

in

**THE GARDEN OF
LIES**

All Star Feature Corp.

220 West 42d Street New York

"THE BOMB BOY"

(Pathe-Eclectic—Three Reels)

REVIEWED BY H. S. FULD

AN exceptionally amusing comedy-drama of the rapid-fire type, in which Ernest Truex is featured as "Lightning Larry," the speed demon. Sparkling with good comedy, exciting situations where the observer is held in tense suspense, excellent photography, and good acting, all go to make this Eclectic release stand out above the average.

Anna Karensky (Eleanor Woodruff) an anarchist, whose actions seem to justify Kipling's saying that the female of the species is more deadly than the male, is the custodian of an infernal machine, with which she intends to put the Grand Duke Serguis out of business.

The Duke (M. O. Penn) on a visit to the United States, is followed on the next steamer by Anna. The secret police have been warned and are waiting for her at the pier. She in turn is warned by wireless by the clique of which she is a member, and frustrates the detectives by hiding the bomb in her hat, while the customs inspector is investigating the contents of her trunk.

Calling a messenger, who happens to be "Lightning Larry," she intrusts the hatbox with her hat and the bomb inside to him with directions to deliver the package to an address uptown. Needless to say the presence of the bomb in the package is known to her alone.

The address given Larry is that of the headquarters of the gang, and after various adventures, in which the package is roughly handled, and the worse for being sat on, banged around, and kicked all over the street by other boys, Larry arrives at the house.

After repeated knockings on the door, it is cautiously opened and the box taken from him at the point of a revolver. His suspicions aroused, Larry gains entrance, hides in a closet, and after a struggle in which he shoots one of the conspirators, dashes through a window and down the fire-escape in pursuit of another of the gang who now has the bomb.

After a rather exciting chase on foot, on a bicycle, by automobile and ferry boat Larry arrives where the Duke is dining, in time to grab the bomb, which is set to explode at seven o'clock. It lacks only two minutes to the hour. Larry succeeds in throwing it over a cliff just as it goes off.

One of the most exciting scenes is where Larry on a bicycle plunges into the river through a gap left by the departing ferryboat between it and the dock. His rescue and the subsequent happenings are amusing in the extreme, and there is enough of a love story running through this number to give it the added touch of realism.

In recognition of his timely assistance the Duke rewards Larry and decorates him with the cross of the Legion of Honor.

An unusually interesting and laugh-provoking release which is brought to a sidesplitting climax when Larry presents his girl Mame (Elaine Ivans) with the medal that was given him by the Duke.

DRIVING A FOUR-IN-HAND FOR FILMS

TO handle a four-in-hand is considered quite a bit of an accomplishment, and Charles Richman, the dramatic star who plays the leading part in the William Fox production of C. Haddon Chambers' great success, "The Idler," which is to be released through the Box Office Attraction Company, is probably the only man who ever stepped nervily to the box-seat of a tally-ho and drove a spanking team with perfect skill and the air of a man who had been "a whip" all his life.

Since he has worked in "the pictures," Mr. Richman has made many interesting discoveries, but the fact that he can handle the ribbons over a quartet of prancing bays and get away with it was something entirely undreamed of in his philosophy heretofore.

ELEANOR WOODRUFF WILL JOIN VITAGRAPH

ELEANOR WOODRUFF, for two years a Pathe feature star, will be a Vitagraph "Life Portrayer" after January 4. Miss Woodruff's acquisition by the Vitagraph Company follows almost on the heels of her statement last week that she had abandoned the screen for a short vacation. It is said that her work for the Vitagraph Company will mainly include appearances in Broadway Star Features.



For those who are interested in personal details—whisper—Eleanor Woodruff was born at Towanda, Pa., in 1892. Her favorite roles are those heavy emotional parts demanding thoughtful acting for which her thorough stage training well fits her. Her beauty is of the majestic type, as captivating off the screen as on. Miss Woodruff not long ago got the Red Cross fever and was on the point of abandoning America to go to the seat of

war in Europe to minister to the wounded and suffering. Her present engagement conflicted with her resolution, and she was persuaded to give up the idea.

RESCUE OF THE STEFANSSON EXPEDITION

THIS is indeed a very creditable offering for any new producing company and one of which the Sunset Motion Picture Company, a San Francisco concern, may well feel proud.

That the company realizes the importance of properly marketing their first production is shown by the arrival in New York of M. E. Cory, their general manager, who has established offices in suite 401, 110 West 40th street.

The Stefansson rescue is one of the greatest pictures ever produced, appealing from a dramatic as well as educational and historical standpoint. If the subsequent releases of the Sunset company keep pace with this picture, their success is assured.

Mr. Cory is emphatic on this point and proudly calls attention to those back of his company. Mr. J. C. Wheeler, Jr., president; Captain H. S. Howland, vice-president; C. J. Parks, a prominent attorney, are the other officers. While the directorate and stockholders include such well-known Californians as Charles K. Field, editor *Sunset Magazine*; U. S. Senator James D. Phelan, Herbert Fleishhacker and C. L. Smith, prominent bankers; Max Schmidt, president Schmidt Litho Co.; Mr. J. H. Henry, one of California's leading capitalists; Judge B. V. Sargent, of the Supreme Court and Mrs. Phoebe A. Hearst.

MANAGER'S SCREEN REPORTS

Furnishing typewritten reports on the quality and character of extra price features prior to release date. Low introductory rates open for short time only. Address:

MANAGER'S SCREEN REPORTS

E. V. Morrison and Harry H. Poppe,
Operators
808 Times Building, New York City

Motion Picture News Release Pages Are Time-Saving Devices Because They Give You

THE SHORTEST WAY and THE EASIEST WAY

TO MAKE UP YOUR PROGRAM

ASK ANY LIVE-WIRE EXHIBITOR IF IT'S TRUE

ALWAYS RIGHT—ALWAYS RELIABLE

A COMIC THRILL FROM ONE OF THE NEW MINA COMEDIES



IN THE HANDS OF THE POLICE—(Scene from "Alias Greased Lightning")

"THE PIT"

(World Film—Five Reels)

REVIEWED BY PETER MILNE

IT may be said without fear of contradiction that "The Pit" is one of the very best releases turned out by the World Film Corporation. The director, Maurice Tourneur, has proven that however old the story in hand may be, it may be effectively treated in its production, causing it to be just as engrossing as if it had never before appeared.

By simply devoting a reasonable amount of attention to detail, a matter often overlooked by producers, Mr. Tourneur has gained some excellent effects, both by the good acting of almost everyone in the cast and the realistic and faultlessly constructed settings.

The word setting brings to mind two big scenes of the picture, namely, the wheat pit spectacle, and previous to this the scenes that are laid in the lobby and the interior of an opera house are modeled after one of the largest in Chicago.

In regard to the former, nothing unfavorable can be said of it. In an exchange scene we have been accustomed to see shaky walls, men taking the parts of brokers who apparently have spent most of their lives as truckmen or the like, and the whole spectacle has often been grossly exaggerated. Here it is not; it is realistic; the men look as if they might have come from State street offices. What is more, they all are blessed with some sort of acting ability; they assume parts in the picture; they are not merely figureheads.

Referring to the scenes in the opera house, the same corresponding praise may be awarded them. While these scenes are not as all-important as the pit scenes—in fact they only afford a meeting place for two of the story's characters—they are not at all superfluous.

After the introduction of the members of the cast, several panoramic views of the city of Chicago are flashed on the screen, this city being the locale of the story. After these introductory pictures, the story starts. It concerns for the most part Jadwin, a man who is soon most happily married. Then he is induced to invest money by a friend; he becomes immensely wealthy and neglects his wife. But quickly the crash comes; he is completely broken—and not until then does he realize the full happiness of his married life; then he starts over again.

Throughout the story colorful and human interest touches are present, possessed with the creative powers of causing the picture to appear unusually true to life.

Wilton Lackaye leads the cast. In the part of Jadwin he leaves nothing out that should be in. Gail Kane is equally convincing as his wife, and Milton Sills as Corthell, the man with whom Laura is about to elope when her husband's financial ruin happily intervenes, is a thoroughly attractive heavy. Alec Francis appears as a wheat broker and Chester Barnett is his secretary. Julia Stuart, E. F. Roseman, and a number of others complete the cast.

HOW CARL PIERCE TACKLED NEW ORLEANS

Special to MOTION PICTURE NEWS

New Orleans, Dec. 22

CARL HORTON PIERCE, general manager of the Bosworth Film Company took a rather unique method of finding out what the people of this section want in the way of moving pictures. Correspondents of MOTION PICTURE NEWS have taken occasion several times to point out that the producers are out of touch with their clients and the general public and that they are especially ignorant of the particular requirements of Louisiana and Mississippi, where peculiarities of the population requires care in selecting the moving picture house programs.

Mr. Pierce believed that he should find out just what the people wanted and he concluded that the best way to do this was to talk it over with the dramatic and moving picture editors. So on his recent visit to the city he entertained the newspaper men connected with his business at a dinner at the St. Charles hotel.

"PATSY AT SCHOOL"

(Lubin—One Reel)

THIS is the first chapter of a series which will tell the unfortunate happenings which follow the life of Patsy Bolivar. "Patsy" has become the synonym for one in bad luck, and poor young Bolivar has more than his share, and mentally resolved to lick any man, woman or child that said that there was no such thing as bad luck.

He has a nemesis in Fred Sykes, nicknamed "Sykesy," who loses no opportunity to get Patsy in trouble. Being of an emotional temperament, he early falls in love. His first object of adoration is his schoolmistress, but he has a powerful rival in Jack Prince, who eventually wins out.

When Patsy sends flowers to the young schoolmarm, Sykesy shakes pepper over the bouquet, and Patsy is sent supperless to bed. Aside from his little sister, Kitty, he has one champion,



THE FIGHT IN THE SCHOOLYARD

Sykesy's sister, Jane, but she fails to attract Patsy, who, upon finding his first love hopeless, transfers his affections to Tilly Grace, who really has no use for him, as her heart is already given to the horrible Sykesy.

With each chapter of the series more misfortune will be told to the credit of this very unlucky boy. The serial will continue for 14 numbers, written by Clay M. Greene and directed by Percy Winter. Patsy is played by Clarence Jay Elmer.

RETRIAL OF EXHIBITOR ON CRIME FILM CHARGE

Special to MOTION PICTURE NEWS

Holland, Mich., Dec. 9.

MANAGER HIMEBAUGH, of the Royal theatre, will be tried a second time on the charge of violating the recently enacted motion picture ordinance. The first case tried resulted in a disagreement of the jury. The picture censored was "The Tragedy of Whispering Creek." The charge against Manager Himebaugh was that by showing such picture he violated a clause in the new ordinance referring to the showing of pictures of crime and bloodshed.

NEW TAX MENACES MONTREAL EXHIBITORS.

Although Managers Are Already Compelled to Pay \$500 a Year to the City, Twenty Cents a Seat to the Provincial Government, and Other Heavy Local Rates, an Alderman Proposes One-Cent Levy Every Time a Seat Is in Use

Special to MOTION PICTURE NEWS

Montreal, P. Q., Dec. 21.

THERE is more trouble looming up for the motion picture exhibitors of Montreal. Having in a great measure succeeded in pulling themselves together after the disturbing influences of war times, they are now to be further harassed by another indirect tax if the proposal of a city alderman goes through.

As things are at present, there is not much profit in a motion picture house. The present taxes are exceedingly heavy. In the first place, the exhibitors have to pay a city tax of \$500 yearly, and then they have to pay a provincial tax of 20 cents a seat per annum. Added to this there are the heavy local taxes, such as water, etcetera. When it is also considered that competition among the exhibitors themselves is extremely heavy—any person whether he be competent or not can hire a small hall and run a motion picture house in competition with the legitimately constructed one—it is apparent that the situation is very bad.

There seems to be an idea among the general run of the public in Montreal that all the exhibitors are absolutely rolling in wealth; and it creates quite a startling surprise when anybody is told authoritatively that the opposite is quite the case, and that after taking everything into consideration, the percentage of profit is very low, considering the amount of risk that is undertaken.

Anyhow, exhibitors are supposed to be a regular gold mine. When it was found that the various charitable organizations in Montreal were in need of increased revenue, the brilliant idea struck certain members of the council that the motion picture exhibitors and their patrons should supply the want.

Want to Tax Patrons Individually

Therefore we have a prominent alderman laying before the legislative Committee of the City Council the proposition that the tax of one cent should be placed on all those who visit motion picture houses. Of course, the alderman was emphatic in stating that the idea was not to tax the proprietor, but the motion picture patrons. But as it is evident that it would be almost impossible to add a cent to every ticket sold, the result would be that the exhibitor would be compelled, in the end, to stand the tax himself.

People are not in the habit of carrying cents around with them, and having put down five, ten or fifteen cents, as the case may be, one can imagine how annoyed the patron would be if he had to dig down into his pocket to find an extra cent or two.

As one exhibitor said, "How could the sale of such tickets be regulated at the busy rush time in front of the ticket office? It would be very hard to work in the extra tickets even if the patron had an extra cent. Then again the greater burden of the tick-

ets would rest on the very people it was intended to support. It is the poor man, therefore, that would suffer."

It is evident from the general opinion of the exhibitors that the imposition of an extra cent tax on tickets would be not only inconvenient for the purchaser, but would cause so much irritation that business would be lost. Therefore it is the exhibitors who would have, in the long run, to pay without increasing the price of admission.

Must Be Fought

It is evident that the proposition will have to be fought tooth and nail, or else at the Legislature the proposal will be suddenly rushed through. Unfortunately, there is one great difficulty in the way of fighting this proposal, and that is that there is no

organization among the exhibitors themselves.

Some time back an organization was attempted, but there was so much jealousy and so much friction among the various members that the project came to nothing. It was found that the better class exhibitors—those who could legitimately be called motion picture managers, the men who have the high class houses—did all the work, while their smaller competitors, who really should not be permitted by the civic authorities to run a house at all, reaped the advantage. Anyhow, the matter is receiving considerable attention, and there is no doubt that some effort will be made to fight this proposal, but up to the present there seems no definite idea how it is to be done.

Holidays Find West Coast Companies Busy

"Heart of Maryland" Under Way—Arbuckle-Bosworth Film to Be Called "It's No Laughing Matter"—Majestic-Reliance News

Special to MOTION PICTURE NEWS

Los Angeles, Dec. 21.

NANCE O'NEIL, who is to be starred in the next production of the Tiffany Film Company, now finishing "The Heart of Maryland," has arrived in Los Angeles and is getting acquainted with the work before the camera preparatory for her engagement.

Fred Burns, Olga Gray, Bob Burns and Eagle Eye are appearing as the principals in the filming of "The Better Man," from the George Pattullo western story of the same name, for a two-reel Majestic release.

"What Might Have Been" is the name of a two-reel Majestic release filmed by John B. O'Brien, in which a youth, Jack Conway, after being forced to commit numerous crimes by his aunt, an elderly woman, played by Mary Alden, is arrested and charged with murder, when the crime was really committed by the woman.

At the last minute the aunt repents and saves the youth from the scaffold. Interwoven is a pretty romance in which a mission worker, Billie West, aids the youth to a better life. Spottiswoode Aitken appears as the uncle of the youth and the scenario is from the pen of Ella Wood.

In the fifteenth of the Bill series by the Komic company, produced at the Majestic-Reliance studio, Bill the office boy sees a fortune in selling hydrant water at prices of the pure bottled spring water, and to make it more desirable empties the contents of a bottle of perfume found in the desk of Ethel, the stenographer, into his supply. Later a henpecked husband spills a quantity of the perfumed water on his coat, trouble starts, and finally, after many complications, Bill's swindle is exposed. The

usual cast of the Komic brand appears.

"Probation" is the title of a one-reel Majestic produced, with Fred Chanler, Cora Drew, Phillip McDermott and Loretta Blake in the Principal parts. The scenario is by J. A. Saxon, a Los Angeles probation officer, and is a plea for leniency for first offenders.

Arrangements were made last week for unusual sets required in the production of the Favorite Players' "High Hand," from the story of Jacques Futrelle. The scenario was prepared by Richard Willis.

The Macklyn Arbuckle-Bosworth picture has been renamed and will be released under the title "It's No Laughing Matter," in which the celebrated character actor appears as Hi Judd, poet, postmaster and philosopher. The release for this picture has been fixed for early in January and it will be given final screen examination within the next few days and shipped to the Paramount New York office soon.

SCREEN CLUB OF SAN FRANCISCO GIVES LUNCHEON

The Screen Club of San Francisco, under whose auspices an unusually successful ball was given late in November, gave a luncheon and dansant on the evening of December 20 to the members of the club and a few invited guests.

Sid Grauman, president of the club, and manager of Loew's Empress theatre, donated the stage of this popular playhouse for the event and the second show given on that evening was known as the Screen Club Show.

The recent ball netted the organization a profit of more than \$2,000 and with this handsome sum as a nucleus preparations are being made to open clubrooms.

Popularity of the Serial Is on the Increase

Elizabeth, N. J., Managers Planned to Discontinue Them But the Public Made Protests—Prove Big Drawing Cards with Indianapolis Audiences

Special to MOTION PICTURE NEWS

Elizabeth, Dec. 23.

MANAGERS of motion picture houses in Elizabeth have come to the decision that their regular programs are not complete without a special feature serial. Two months ago some of the managers were outspoken in their belief that the future of special feature serials, especially in this city, was not bright.

They even went so far as to announce that when contracts for the serials then being played expired there would be no similar ones to take their places. Most of the big houses, however, have finished with "The Perils of Pauline" and "The Million Dollar Mystery" and other serials of later release have been contracted for to take their places.

The apparent change of purpose was the result of careful experiment. The majority of the local managers ran the serial features for three days. Without announcing the change of plan several of the local managers omitted the serial feature for a single day each week.

The unexpected happened. A large number of patrons personally visited the managements when such omissions occurred, others wrote letters of protest and indignation. The objections were so many and general that local managers decided they could not be overlooked.

But with the continuation of the serial feature as a part of the regular weekly

program there has been shown a change of policy on the part of the exhibitors. Instead of a three-day run, the managers are putting on the serial feature for a single day each week.

"The Million Dollar Mystery," which held forth at the Garden Theatre for three days every week, has been succeeded by "Zudora," which is given to the patrons but one day, and "The Master Key" holds forth at Proctor's Broad Street Theatre one day each week.

The smaller houses have already begun to follow the lead of the more prominent motion picture playhouses in Elizabeth, and special features that were generally exhibited for several days are now rarely shown longer than the time taken by the performances of a day each week.

FRANK M. BOYCE, JR.

Serials Supreme in Middle West

Special to MOTION PICTURE NEWS

Indianapolis, Dec. 23.

The serial pictures seem to be the big drawing cards in all the houses. Already the "Master Key" is bringing crowded houses to those who have been fortunate enough to get bookings.

J. G. Conner, local representative for "Zudora" and "The Million Dollar Mystery," is still making bookings on the "Mystery." He expects to exceed these with "Zudora," practically all the exhibitors following the "Mystery" with "Zudora."

Thirty Detroit Women to Become Censors

Members of Child Welfare Committee Assume Duty of Scrutinizing All Films in City at Cost of \$1,000 a Year to Club

Special to MOTION PICTURE NEWS

Detroit, Dec. 22.

PLANS have been completed for the censoring of films in Detroit by a committee, consisting of 30 ladies, with Mrs. E. F. Leonard as chairman, who comprise the Child Welfare and Civic committees of the Detroit Federation of Women's Clubs.

This committee is divided into various sections, and all parts of the city will be thoroughly covered. It is the purpose of the association to make public any films which they believe are undesirable, but the name of the playhouse is not to be mentioned, as the committee claim they do not want to do anything to injure any man's business, but rather to simply protect young boys and girls from bad influences, possible through pictures bordering on the immoral.

Owing to the fact that these lady censors are not officially authorized to carry on such work, no free admissions will be granted them. They will have to "come across" with the regular price in every instance, which means that if they visit houses once a day, the cost will be an average of \$3 per day to the club, or practically \$1,000 per year. The question is how long will the club endure this unnecessary expense.

A representative of MOTION PICTURE

NEWS asked several leading managers of theatres what their opinion was of this new form of censorship. Invariably the answer came back:

"We really are not in a position to comment one way or the other until the plan is working. If these ladies want to come into our theatres, we will be glad to have them, as long as they pay the regular admission price and show that they are not endeavoring to interfere with our business. They will have very little to find fault with at any of the legitimate houses; there may be six or seven theatres that try to 'slip things over' by showing films below the usual standard, and it is to this sort of houses that their efforts should be concentrated, and not at the better class of playhouses, because the proprietors of the latter type of theatres are just as anxious as anybody to keep their brand of entertainment above reproach."

ANOTHER NEWSPAPER MAN JOINS UNIVERSAL

Arthur M. Brillant, formerly with the New York City News Association, and before that with Middle West and Pacific Coast newspapers, has joined the publicity staff of the Universal. He will be in charge of the Universal's syndicate service.

PAUL PANZER ON VAUDEVILLE TOUR

Paul Panzer, who as Raymond Owen meets death by drowning, in the last episode of "The Perils of Pauline," has decided to take a few weeks' vacation by doing work of another sort. Bill Casey, nephew of Pat Casey, saw him in a vaudeville act over in Brooklyn several months ago and



PAUL PANZER

decided that on the conclusion of "The Perils of Pauline" he wanted to book the popular villain for an extended vaudeville tour.

So "Oom Paul" started in at the Auditorium in Malden, Mass., on December 14, for a week's engagement, and after New Years will play engagements in various cities for fifteen weeks straight. On the expiration of his vaudeville contract he will return to Pathé.

"FLORA FOURFLUSH" COMEDIES ARE READY

The announcement has been made that the Vitagraph Company would release on Monday, January 4, and the two following Mondays; "The Ten-Billion Dollar Mystery Serial," entitled, "The Fates and Flora Fourflush," in three parts, the first part, "Treachery in the Clouds," to be released on Monday, January 4; part 2, "The Treasure Temple of Bhosh," released Monday, January 1, and part 3, "A Race for Life," released January 18.

After making this statement the question arose as to whether the people would take the announcement seriously or come to the conclusion that it was a hodge-podge of nothing. These three releases are not to be taken seriously and cannot in any way be discounted as comedies of the funniest and most convulsing nature. "The Fates and Flora Fourflush" in its separate releases, make one of the most laughable burlesques on the thrilling, perilous and daredevil concoctions.

SCREEN ACTING NOT FATIGUING, SAYS JACKIE SAUNDERS

A peculiarity of screen acting observed by the majority of players and voiced in particular by a prominent actress now in one of the leading producing companies in California is the absence of monotony and fatigue in work before the camera.

In this respect it has a great advantage over the "legitimate," especially stock companies. The experience of Jackie Saunders, the leading woman of Balboa, at Long Beach, Cal., is typical of this feeling among players who have been long enough on the stage and in films to notice the contrast in favor of the latter.



JACKIE SAUNDERS

Miss Saunders, who in her three years of screen work was with the Biograph and Universal companies before signing with Balboa, where she has been almost a year, voiced the sentiment in a recent interview on her visit to New York after an absence of nearly three years from the East.

Miss Saunders declared that eight hours' steady work for the camera was less trying than half the time on the "legitimate." The variety of the duties exacted of the players, not possible on the stage, is the reason. There is no endless playing of the same part night after night, as she experienced in the Orphcum Stock Company, of Philadelphia, for instance.

Once a character is interpreted before the screen, the player leaves it for all time and takes up a different role. Miss Saunders, who played opposite Edwin August while with the Universal, and on her recent visit to her mother in Philadelphia for Thanksgiving ran over to New York to see old friends before returning to California, soon discovered in this constant change of parts an interesting psychological condition.

The variety of the work had a sustaining influence on her powers of endurance. In contrast to the deadening monotony of stock, she experienced a freshness and quick recuperative response to the next scenario requirements little short of the marvelous.

Miss Saunders prefers ragged boy parts.

Government Department Sees Lubin Naval Films

Pictures of Torpedo Boat Destroyer Flotilla Racing at Rate of Thirty-three Knots an Hour, Will Be Seen Later at Panama Exposition

AN unusually interesting series of motion pictures of the United States Navy, taken at Newport, R. I., has just been completed by the Lubin Manufacturing Company, of Philadelphia, and presented to Secretary of the Navy Daniels by Siegmund Lubin.

These special reels will be shown in the navy department and later will be sent to the naval section at the Panama-Pacific Exposition in San Francisco, where the public will have an opportunity of seeing the excellent work being done by the officers and men of the United States Navy.

Perhaps the most striking of the pictures are the manoeuvres of the torpedo boat destroyer flotilla, the type of warcraft that Major Goethals, of Panama, has asked for to prevent English and other warships from violating neutrality laws off the canal. These boats are the fastest in the navy and the Lubin pictures show them racing to sea, making thirty-three knots an hour, and how they

would attack an enemy with guns and torpedoes.

Incidentally the commander of the fleet demonstrated for the camera men how the fleet can race at high speed in close formation without a bit of smoke coming from any smokestack and then at a signal dense, impenetrable smoke is fired from every smokestack on every boat forming, an immense curtain which would completely screen the home fleet from an attacking fleet.

At the government's training station the camera men secured pictures that illustrate in detail how Uncle Sam supplies his ships with sailors. These pictures contain the famous exhibition drills and sham battles that the government stages every summer at Newport as a regular event.

The Lubin company will keep a set of these pictures to place in a big vault in which is kept records of important personalities and events of national importance.

THOMAS HOLDS "AD" DESK FOR KRITERION PROGRAM

A new face is seen in the advertising field in the person of W. D. Thomas, who comes from the commercial field.

For the past four years Mr. Thomas



W. D. THOMAS

has been advertising and sales manager of the U. S. Linen Company, Chicago. He is now advertising manager of the Mica Film Corporation, which is putting on the Kriterion Program.

Mr. Thomas considers film as much a commercial commodity as any merchandise and states that advertising copy should follow along this line.

One of his novel advertisements appeared last week in the form of a football selection, using his brands as players on the All-American team. Very favorable comments on this ad, have been passed through the trade.

SHELDON LEWIS SIGNS WITH PATHE FOR NEW SERIAL

Sheldon Lewis, whose interpretation of Dutch Joe in W. A. Brady's big production of "Life" at the Manhattan Opera House, is attracting such favorable notice, has been signed by Pathe to take a prominent part in the new serial, "The Exploits of Elaine."



SHELDON LEWIS

Mr. Lewis was born in Philadelphia of German-American parentage.

He has had leading roles with such stars as Dorothy Donnelly, Frances Starr and Blanche Walsh, as well as with Ada Rehan in Shakesperian plays.



MERRY
CHRISTMAS
and
HAPPY
NEW YEAR

RELEASED
by the
KINETOPHOTE
to every
EXHIBITOR

GET ACQUAINTED WITH US
IN 1915

IT'S OUR BIG YEAR
and
WE CAN HELP YOU

THE
KINETOPHOTE
126-132 West 46th Street
NEW YORK
Telephone: Bryant *6072

Frederick A. Thomson

Producer of

The Famous Players Spectacle

"The Sign of The Cross"



Future Releases:

"THE GOOSE GIRL"

"THE COUNTRY BOY"

For The Jesse L. Lasky Feature Play
Company

"GERTIE, THE DINOSAURUS"

(Box Office—One Reel)

REVIEWED BY PETER MILNE

WINSOR McCAY'S conception of the far-famed dinosaur, as pictured in this reel, is proof conclusive that he is one of the best of the present-day comic artists. It will be everyone's sincere wish after witnessing this comical animated cartoon of his creation that he do more work for motion pictures.

Take it from the titles in the picture, Mr. McCay did the job on a bet that he could draw a likeness of the prehistoric animal (we get the name twisted when attempting to pound it out on the typewriter), and make it perform in the manner he ordered.

His orders to the beast, which stands gaping on the screen, are funny, but Gertie's actions are funnier still. She walks out of her cave and bites off and swallows the top of a tree, resembling somewhat the manner in which a giant would consume a stalk of celery. Other of her actions are picking up an elephant and swinging him far into a lake and later drinking the lake dry.

McCay wins his bet in the finale, and George McManus is obliged to foot the dinner bill. We don't envy Mr. McCay his job, as the film tells us he had to draw ten thousand pictures, each one differing slightly from the other, but we appreciate his finished work, and everyone else will after seeing "Gertie."

"MRS. WIGGS" IS NEXT CALIFORNIA PRODUCTION

"MRS. WIGGS of the Cabbage Patch," the California Motion Picture Corporation's second big feature production, will be released on the World program on January 4. The screen story combines Alice Hegan Rice's two famous novels, "Mrs. Wiggs" and "Lovey Mary," which were successfully dramatized by Anne Crawford Flexner under the former title, and produced by Liebler & Co. in 1903 at the Savoy Theatre, New York City. The play has had great vogue, passing around the world, has been played in all English-speaking countries and translated into German.

Beatriz Michelena, whose work in "Salomy Jane" has brought her to the front rank in filmdom with one stride, appears as "Lovey Mary," the good angel of the drama, while Blanche Chapman plays "Mrs. Wiggs."



What Do You Need?

LISTING IN THE BUYERS' GUIDE, FOR NAME AND ADDRESS, INCLUDING ONE YEAR'S SUBSCRIPTION TO MOTION PICTURE NEWS—\$8.00 A YEAR, CASH IN ADVANCE. FREE TO ADVERTISERS USING \$100.00 OR MORE WORTH OF DISPLAY SPACE DURING THE YEAR. ADDRESS ADVERTISING DEPARTMENT

ADVERTISING NOVELTIES

Philip Hano, 806-810 Greenwich St., New York.

ANNOUNCEMENT SLIDES

Niagara Slide Co., Lockport, N. Y.

ASBESTOS BOOTHS

Sharlow Bros., 442 W. 42nd St., New York.

COSTUMERS

Miller-Costumier, 235 South 11th St., Philadelphia, Pa.

DEVELOPING TANKS

A. J. Corcoran, Inc., 9½ John St., New York.

ELECTRIC LIGHTING SETS

The Chas. A. Strelinger Co., Box P-2, Detroit, Mich.

FILMS

(Manufacturers, Dealers and Renters)

American Film Mfg. Co., Chicago, Ill.

Thomas A. Edison, Inc., 275 Lakeside Ave., Orange, N. J.

Essanay Film Mfg. Co., First National Bank Bldg., Chicago, Ill.

General Film Co., 200 Fifth Ave., New York.

George Kleine, 166 N. State St., Chicago, Ill.

Lubin Mfg. Co., Philadelphia, Pa.

G. Melies, 204 E. 38th St., New York.

Mica Film Corporation, 220 W. 42d St., New York.

Mutual Film Corp., 71 W. 23rd St., New York.

New York Motion Picture Corp., Longacre Bldg., New York.

Pathé Freres, 1 Congress St., Jersey City, N. J.

Renfax Film Co., Inc., 110 W. 40th St., N. Y.

Selig Polyscope Co., Chicago, Ill.

The Balhau Amusement Producing Co., Long Beach, Cal.

Thanhouser Film Corp., New Rochelle, N. Y.

Universal Film Mfg. Co., 1600 Broadway, N. Y.

FILM ACCESSORIES

Berlin Aniline Works, 213 Water St., New York.

FILM TITLES, PRINTING, DEVELOPING, ETC.

Commercial Motion Pictures Co., Inc., 220 W. 42nd St., New York.

Centaur Film Co., 670-682 Ave. E, Bayonne, N. J.

Evans Film Mfg. Co., 412-22 W. 216th St., at Broadway, New York.

Gunby Bros., Inc., 145 W. 45th St., New York.

Industrial Moving Picture Co., 223-233 W. Erie St., Chicago.

Standard Motion Picture Co., 5 S. Wabash Ave., Chicago.

Standard Filmprint Corp., 120 School St., Yonkers, N. Y.

FILM REELS

Lang Mfg. Works, Olean, N. Y.

Taylor-Shantz Company, 224 Mill St., Rochester, N. Y.

FURNITURE AND FURNISHING ON RENTAL

William Birns, 103-105 West 37th St., New York.

FEATURE FILMS

Alco Film Corp., 218 W. 42d St., New York.

Alliance Films Corp., 126 W. 46th St., New York.

Albuquerque Film Mfg. Co., Inc., 406 Court St., Los Angeles, Calif.

All Star Feature Corp., 220 W. 42d St., New York.

Ambrosio American Co., 15 E. 26th St., New York.

Bosworth, Inc., 648 South Olive St., Los Angeles, Cal.; New York office, 220 W. 42d St.

Box Office Attraction Film Rental Co., 130 W. 46th St., New York.

Blinkhorn Photoplays Corp., 110 W. 40th St., N. Y.

California Motion Picture Corp., San Francisco, Cal.

Cosmofotofilm Co., 110 W. 40th St., New York.

Cosmos Feature Film Corp., 126-130 W. 46th St., New York City.

Direct-From-Broadway Features Co., 46 W. 24th St., New York.

Eclair Film Co., 126 W. 46th St., New York.

Eclectic Film Co., 110 W. 40th St., New York.

Excelsior Feature Film Corp., Inc., 110 W. 40th St., New York.

E. & W. Transfilm Bureau, 110-112 W. 40th St., New York, N. Y.

Favorite Players Film Co., 110 West 40th St., New York.

Features Ideal, 126 W. 46th St., New York.

Famous Players Film Co., 213-229 W. 26th St., New York.

Films Lloyds, Inc., 220 W. 42nd St., New York.

General Film Co., 200 Fifth Ave., New York.

General Feature Film Co., 313 Mallers Bldg., Chicago, Ill.

Gaumont Co., 110 W. 40th St., New York.

Greene's Feature Photo Plays, Inc., 110 W. 40th St., New York.

W. W. Hodkinson, 110 W. 40th St., New York.

Imperial Motion Picture Co. of N. Y., Inc., 1476 Broadway, New York.

Inter-Continent Film Co., 110 W. 40th St., N. Y.

George Kleine Attractions, 166 N. State St., Chicago, Ill.; New York office, 1476 Broadway.

Jesse L. Lasky Feature Play Co., Longacre Theatre, New York.

Life Photo Film Corp., 220 W. 42nd St., N. Y.

Mecca Feature Film Co., Inc., 126 W. 46th St., New York.

Mohawk Film Co., Times Bldg., New York.

Oz Film Mfg. Co., Santa Monica Blvd., Los Angeles, Cal.

Paramount Pictures Corp., 110 W. 40th St., N. Y.

Phoenix Feature Film Corp., 129-131 Columbus Ave., Boston, Mass.

Photo Play Production Co., 220 W. 42nd St., N. Y.

Picture Playhouse Film Co., 110 W. 40th St., New York.

Playgoers Film Co., Lyric Theatre, New York.

Popular Plays and Players Co., 218 W. 42d St., New York.

Progress Film Co., 110 W. 40th St., New York.

Progressive Motion Pictures Corp., Times Bldg., New York.

Ramo Films, Inc., Columbia Theatre Bldg., N. Y.

Rolands Feature Film Co., 145 W. 45th St., N. Y.

A. H. Sawyer, Inc., 1600 Broadway, New York.

Select Photo Play Producing Co., Inc., 110 W. 40th St., New York.

Sterling Camera & Film Co., 145 W. 45th St., New York.

Solax Co., Fort Lee, N. J.

The Masterpiece Film Mfg. Co., 1111 Van Nuy Bldg., Los Angeles, Cal.

The Balhau Amusement Producing Co., Long Beach, Cal.

The Photoplay Productions Releasing Co., 37 S. Wabash Ave., Chicago, Ill.

Union Features, 126 W. 46th St., New York.

Universal Film Mfg. Co., 1600 Broadway, N. Y.

University Films, Inc., 110 W. 40th St., N. Y.

Edw. H. Wagner, Agt., Dania Biofilm Co., 38 Park Place, New York.

World Film Corporation, 130 W. 46th St., N. Y.

Warner's Features, Inc., 130 W. 46th St., N. Y.

LANTERN SLIDE MATS AND REEL BANDS

Lantern Slide Mat Co., 149 W. 35th St., N. Y.

LABELS

Every Ready Roll Label Co., 203-7 W. 40th St., New York City.

LIGHTING PLANTS

Cushman Motor Works, Lincoln, Neb.

LOBBY PHOTOS

The Wyanoak Pub. Co., 136 W. 52nd St., N. Y.

MOTION PICTURE MACHINES AND SUPPLIES

Amusement Supply Co., 160 E. North Fifth Ave., Chicago, Ill.

Behrend Motion Picture Supply House, 440 Fourth Ave., New York.

Calehuff Supply Co., 1301 Race St., Philadelphia, Pa.

Enterprise Optical Co., 568 W. Randolph St., Chicago, Ill.

Lears Theatre Supply Co., Sam Lears, Prop., 509 Chestnut St., St. Louis, Mo.

Oliver Moving Picture Supply Co., 647 Euclid Ave., Cleveland, O.

Picture Theatre Equipment Co., 21 E. 14th St., New York.

Precision Machine Co., 317 E. 34th St., N. Y.

Nicholas Power Co., 90 Gold St., New York.

The Phantascope Mfg. Co., Washington, D. C.

Sweeley's Photo Supply House, 514-516 Erie Ave., Renova, Pa.

Williams, Brown & Earle, Inc., 916-918 Chestnut St., Philadelphia, Pa.

MOTION PICTURE APPARATUS

Burke & James, Inc., 240-258 E. Ontario St., Chicago, Ill.

MUSICAL INSTRUMENTS

American Photo Player Co., 62 W. 45th St., N. Y.

Rudolph Wurlitzer Co., Cincinnati, O.

OPERA CHAIRS

The Hardy Mfg. Co., Canal Dover, Ohio.

Steel Furniture Co., Grand Rapids, Mich.

POSTER AND PICTURE FRAMES

Menger & Ring, 442 W. 42nd St., New York.

Newman Mfg. Co., 717 Sycamore St., Cincinnati, O.

PIPE ORGANS

Henry Pilcher's Sons, 914-920 Mason Ave., Louisville, Ky.

M. P. Moller, Hagerstown, Md.

PROJECTION LENSES

Bausch & Lomb Optical Co., 569 St. Paul St., Rochester, N. Y.

POSTERS

The Morgan Lithograph Co., Cleveland, Ohio.

RAW FILM

Eastman Kodak Co., Rochester, N. Y.

Celluloses Planchon, Inc., 75 Fifth Ave., N. Y.

David Horsley, Bayonne, N. J.

Raw Film Supply Co., 15 E. 26th St., New York.

REWINDERS AND GENERAL SUPPLIES

L. C. Smith Co., Schenectady, N. Y.

SCREENS

Atsco, Inc., 218 West 42nd St., New York.

Day & Night Screens, Inc., 110 W. 40th St., N. Y.

Mirror Screen Co., Inc., Shelbyville, Ind.

STEEL FILM EQUIPMENT FOR EXCHANGES AND MFRS.

Columbia Metal Box Co., 226-228 E. 144th St., New York.

TICKETS—ROLL AND COUPON

Rees Ticket Co., 400 S. 10th St., Omaha, Neb.

THEATRE LOBBY FRAMES AND FIXTURES

Newman Mfg. Co., 715 Sycamore St., Cincinnati, O.

UNIFORMS

Fechheimer Bros., Union-made Uniforms, Cincinnati, O.

The Idler - Samson



THE IDLER with CHARLES RICHMAN

Supported by Cathrine Countiss, Claire Whitney, Stuart Holmes and Walter Hitchcock

The Idler is the wonderful Frohman success with the heart-throbbing elements of love, the stage, a millionaire and his money, intrigue, folly and romance of gay life. A powerful five-reel picture.

SAMSON with WILLIAM FARNUM

By Henri Bernstein, author of "The Thief."

Samson recites the rise of a dock laborer to a man of millions. He marries into a financially decayed aristocratic family for social prestige, but his wife despises him. His love struggle ends in his ruin—yet he succeeds in his ambition.

CURRENT RELEASES

Dorothy Donnelly and Richard Buhler in "The Thief," by Henri Bernstein.

Edmund Breese in "The Walls of Jericho," by Alfred Sutro.

"Life's Shop Window," with Claire Whitney, by Victoria Cross.

"St. Elmo," with an all-star cast, by Augusta Evans.

THE BOX OFFICE ATTRACTION EXCHANGES

Also supply three and four-reel American Features.

Releasing one-reel comedies, including Winsor McCay's "Gerties."



WILLIAM FARNUM — SAMSON



CHARLES RICHMAN-CATHRINE COUNTISS-THE IDLER

A Fool There Was



WILLIAM FOX PRODUCTION

A FOOL THERE WAS

ROBERT HILLIARD'S GREATEST SUCCESS
A PICTURIZATION OF RUDYARD KIPLING'S

"VAMPIRE"

DRAMATIZATION BY PORTER EMERSON BROWNE

A FOOL THERE WAS

Brilliant assemblage of artists
\$100,000 worth of women's gowns shown
The greatest photoplay production in history
A theme that will strike every man, woman and child
Wonderful sets by arrangement with Tiffany, New York
Gorgeous Florida outdoor scenery—The Fountain of Youth
Directed by Frank Powell—with Theda Bara and Edward Jose

PHONE OR WRITE:

BOX OFFICE ATTRACTION COMPANY

WILLIAM FOX, President

130 West 46th Street, New York City



THE FOOL ON THE BRIDGE OF HIS YACHT

NEW YORK CITY—126 W. 46th St. Phone: Bryant 7340
WASHINGTON, D. C.—305 9th St. Phone: Main 1426
POSTON, MASS.—10-12 Piedmont St. Phone: Oxford 4658
SYRACUSE, N. Y.—400 Eckel Theatre Bldg. Phone: Warren 119
PHILADELPHIA, PA.—1333 Vine St. Phone: Walnut 1503
PITTSBURG, PA.—121 Fourth Ave. Phone: Court 1302
CLEVELAND, O.—618 Columbia Bldg. Phone: Cuyahoga Central 6260R Bell: Main 5677
ST. LOUIS, MO.—3632 Olive St. Phone: Bell: Lindel 795. Kinloch, Delmar 4363
KANSAS CITY, MO.—928 Main St. Phone: Bell: Main 1008 Home: Main 7253
DALLAS, TEXAS.—1907 Commerce St. Phone: South West—Main 2066
SAN FRANCISCO, CAL.—107 Golden Gate Ave. Phone: 4880 Market
DENVER, COLO.—Ideal Bldg., 17th and Champa Sts. Phone: Main 5071
MINNEAPOLIS, MINN.—Jeweler's Exchange Bldg. Phone: North Western Nicollet: 2498
CHICAGO, ILL.—314 Mallers Bldg., 5 S. Wabash Ave. Phone: Central 1716
SEATTLE, WASH.—1214 Third Ave. Phone: Elliott 1039
SALT LAKE CITY, UTAH—McIntyre Bldg.



THE VAMPIRE AND HER ACCOMPLICE

**What Makes
A Feature
A Feature?**

1. *Every feature must stand the acid test of box of-*

fice value. The power to draw the money. To do this it must be a picture easy to understand. It must combine human interest with comedy and pathos.

2. *Not alone is good acting a prime necessity, but care should be taken in the making of the print.* A bad print offends and displeases the theatre patron, thus affecting the exhibitor. Take care of the exhibitor and he will take care of the manufacturer.

3. *Personal exploitation of business directors exerts no influence on the box office.* The same amount of energy spent on publicity for the feature gives it a distinction that makes it worth featuring

**What the Alliance Programme
Stands For**

1. *As near perfection as the human element can*

make it. An earnest and honest endeavor to make each succeeding release better than those that have gone before. Progress is the foundation of our policy. Ask our patrons if this is true.

2. *We will not handle off colored shoddy.* Our features appeal to all classes. They combine entertainment, divertissement and instruction.

3. *We offer you regularity, reliability and respectability.* Regularity of release, reliability of character of output and respectability of subjects.

What We Have Done

- "THE LAST CHAPTER" with **CARLYLE BLACKWELL**
By **RICHARD HARDING DAVIS**
- "THE TRUTH WAGON" with **MAX FIGMAN** and **LOLITA ROBERTSON**
From the play by **HAYDEN TALBOT**
- "THE LAST EGYPTIAN" with **J. FARRELL McDONALD** and **VIVIAN REED**
From the book by **L. FRANK BAUM**
- "HEARTS AND FLOWERS" with **MRS. THOMAS WHIFFEN**
From the celebrated play of the same name
- "THE MAN WHO COULD NOT LOSE" with **CARLYLE BLACKWELL**
By **RICHARD HARDING DAVIS**
- "THE HOOSIER SCHOOLMASTER" with **MAX FIGMAN** and **LOLITA ROBERTSON**
From the great American story by **EDWARD EGGLESTON**
- "WHEN FATE LEADS TRUMP" with **OCTAVIA HANDWORTH**
From the novel by **JOHN HYMER**
- "THE KEY TO YESTERDAY" with **CARLYLE BLACKWELL**
From the novel by **CHARLES NEVILL BUCK**
- "THE PATH FORBIDDEN" with **OCTAVIA HANDWORTH**
From the novel by **JOHN HYMER**
- "AT THE OLD CROSS ROADS" with **ESTHA WILLIAMS**
From **ARTHUR C. AISTON'S** famous play

Every one of these has made good

The Alliance Programme makes money for the exhibitor

We Can Prove It

Ask Us How

EXCHANGES

ALLIANCE FILM SERVICE, 115 Fourth Ave., Pittsburgh, Pa. A. A. Well-land, Mgr. Ohio, Western Pennsylvania, Kentucky and West Virginia. (Kentucky exhibitors served from Cincinnati office.)

ALL THEATRES FILM AND ACCESSORY CO., INC., Owners of Alliance Exchanges. New York State, Buffalo office, 18 Chapin Block; New York City office, 126 West 46th St.; M. F. Tobias, Gen. Mgr.

ALLIANCE FILM SERVICE, controlled by Eastern Feature Film Co., Inc., 57 Church St., Boston, Mass. New England.

ALLIANCE FEATURE FILM SERVICE, controlled by Mecca Feature Film Co., 130 West 46th St. Northern New Jersey.

ELECTRIC THEATRE SUPPLY CO., Vine and 13th Sts., Philadelphia, Pa. Southern New Jersey, Eastern Pennsylvania, Maryland, Delaware, District of Columbia and Virginia.

CASINO FEATURE FILM CO., Dime Savings Bank Bldg., Detroit, Mich. Michigan.

ALLIANCE FILM CO. OF TEXAS, 1905½ Commerce St., Dallas, Texas. Texas, Oklahoma, Louisiana, Arkansas.

HYBAR FILM CORP., Forsythe Building, Atlanta, Ga. Georgia, Alabama, Mississippi, Tennessee, Florida, North and South Carolina.

CELEBRATED PLAYERS FILM CO., 64 West Randolph St., Chicago, Ill. Illinois and Indiana.

NAT A. MAGNER CO., Pacific Bldg., San Francisco, Cal.; 218 Superior Theatre Bldg., Los Angeles, Cal. California, Nevada and Arizona.

DES MOINES FILM SUPPLY CO., 218 Utica Bldg., Des Moines, Ia. Iowa.

MONARCH FEATURE FILM CO., 12th and Wyandotte Sts., Kansas City, Mo. Missouri, Kansas and Nebraska.

ZENITH FEATURE FILM CO., Lyceum Bldg., Duluth, Minn. Minnesota, North and South Dakota and Wisconsin. Milwaukee Office, 407 Manhattan Building.

ALLIANCE FILM SERVICE, controlled by Noted Players Feature Film Co., 613 New Birks Bldg., Montreal. Jas. D. Goldie, Gen. Mgr. Canada.

ALLIANCE PROGRAMME FEATURE SERVICE. Exchanges located at 710 Northwestern Bank Bldg., Portland, Ore.; 1214 Third Ave., Seattle, Wash.; 809 Trent St., Spokane, Wash.; 27 N. Park St., Butte, Mont.; 607 Ideal Bldg., Denver, Col. Supplying States of Washington, Oregon, Montana, Idaho, Wyoming, Colorado, Utah and New Mexico.

ALLIANCE FILMS CORPORATION

126 WEST 46TH STREET, N. Y.

Better to read fifty advertisements than to miss the one YOU need.

THE MASTERPIECE FILM MFG. CO.

Presents

MAX FIGMAN

Supported by

Miss Lolita Robertson in

THE TRUTH WAGON

IN FIVE PARTS

A Brilliant Comedy Drama of Newspaper life, love and politics, from the play by Hayden Talbot—showing a Metropolitan daily in the making. Marvelous typesetting machines and giant presses are backgrounds for some of the big scenes in this production. Abounding in tense moments, strong climaxes and mirth provoking situations.

Mr. Figman is seen at his best as the easy going, devil may care John Ross, who buys a newspaper, and proceeds to follow a campaign of truth telling. He defeats his own father who runs for the governorship, makes enemies of his friends, overturns the most powerful political machine in the country, ruins himself financially and brings his meteoric exploits to a close by falling in love and making the father of his sweetheart Governor of New York State.

Released on the

ALLIANCE PROGRAMME

MASTERPIECE FILM MFG. CO.

LOS ANGELES, CAL.

"FALSE COLOURS"

(Bosworth-Paramount—Four Reels)

REVIEWED BY H. S. FULD

IN this film of Bosworth's, made by the Smalleys, some of the finest interior settings, showing the interior of a large theatre, are presented. Not to mention this deviating from the beaten path of "Prop Scenes" would be slighting the honest efforts of a producer who has gone to greater lengths than the average to make a theatre scene realistic.

One of the scenes, taken from the rear of the orchestra seats, shows the entire stage and boxes on each side, over the heads of the seated audience. From viewing the scene one gets the impression that with the audience he is seeing the making of a star, and the repeated curtain calls and applause of the audience depicted by wonderfully clear photography only helps in the illusion.

Too much credit cannot be given the producers, for this is only one of the good points.

Phillips Smalley in the role of Lloyd Phillips plays the part in his own inimitable manner and, supported by Lois Weber, Dixie Carr and a well-chosen cast, he manages to put a fervor and realism into the part that makes a scarcity of necessary sub-titles fade into insignificance.

Phillips, a famous actor, whose wife dies just before he arrives at her bedside, cannot bear the sight of his baby girl, whom he blames for her death. Giving her in charge to his housekeeper and providing for her education and sustenance, he goes away to forget.

Eighteen years later, the daughter, now a young lady (Dixie Carr), learning that the funds intended for her were being appropriated by her guardians to support their dissolute son, Bert, in luxury, runs away and goes on the stage under the direction of an old friend of her father, Marc Herbert (Herbert Standing). Courtney Foote here gives a remarkable impersonation in the character of the son.

Mrs. Moore, who all these years has been secretly in love with Phillips, is employed in the same theatre, and succeeds in getting



HER MOTHER'S DYING REQUEST

her daughter Flo in the same cast. But Flo at the instigation of Bert impersonates the actor's daughter when he returns home. Lois Weber plays both mother and daughter.

It is all straightened out in the end. Phillips finds his daughter, marries Flo, and a very original and pleasing drama has been produced.

ROSKAM RELEASES "ANOTHER GIRL"

EDWARD ROSKAM, of Life Photo, is the proud father of a girl. The little lady arrived in her new home at 12:45 Monday morning, December 21. Two hours before that time the happy mother, with Eddie, was enjoying a special performance of "The Pit," which was being run at the Playhouse, for Wilton Lackaye.

Eddie seems partial to girls, as he now is the happy father of a blonde and a brunette.

"THE ITALIAN"

(Ince-Paramount—5,500 feet)

REVIEWED BY H. S. FULD

IN the character of Beppo Donetti, George Beban gives a masterly example of what an actor who is alive to his role and can feel his part, can do in the way of holding an audience in sustained tension.

By facial expression and the natural gestures with the hands he is capable of depicting so many different phases, so many different emotions, that though the action is only on the screen, we wonder why it is said that the screen has its limitations. It is nothing less than wonderful.

Coupled with good clear photography, well-chosen interior settings, and a few startling innovations, such as hanging on the running-board of a rapidly-moving automobile, being thrown off by



BEPPLO'S VICTIM FOILS HIS REVENGE

a kick in the face, and so on, the acting of Beban makes a rather pleasing and interesting production out of a story whose plot is nothing out of the ordinary.

The story of the immigrant toiling in a foreign land to earn enough to bring his prospective bride to his side from their native land, and their subsequent struggles to subsist on the barest living wage, has been used over and over again.

But with the help of about 1,500 feet of film devoted to scenes in the native Italy, and the introduction of the political boss in the city of the land of the free, a rather novel twist is given to the story, and it is made a better one than the average.

On his release from prison, where he has been sent for trying to get milk for his dying child, Beppo learns of the girl's death and holds the political boss indirectly responsible. Remembering past favors rendered by him to the boss, he had expected help from that quarter only to be literally thrown in the gutter.

Learning of the illness of the boss' baby, a few days later Beppo, by impersonating a peddler, secures entrance to the house. He hears the doctor tell the father that the slightest sound or shock will prove fatal to the child, and when the child is left alone for a moment, Beppo attains the side of the crib. Raising aloft the glass shade of a lamp, he is about to dash it to the floor, when a slight movement of the child's arm brings to mind that his own child was wont to make the same gesture. Gently lowering the shade, Beppo steals away.

Altogether the scenes in the last thousand feet are heart-rending, and the pathos as expressed on the face of Beppo and his wife, Annette (Clara Williams) is enough to move the average audience to tears. The story interests, is well told, and it should be well received by any appreciative audience.

THREE INDIANA THEATRES RAISE PRICES

Special to MOTION PICTURE NEWS

Louisville, Ky., Dec. 22

THE three motion picture theatres at Princeton, Ind., inaugurated an increase in prices this week of from five to ten cents. The reason given for the raise is that the exhibitors have to meet an increased cost for films and service, generally.

Farnum Plays Strenuous Part in "Samson"

Fox Actor, Powerful in Build and Muscular Development, Hurls Fellow Player Through Door of Set at Rehearsal

Special to MOTION PICTURE NEWS

WILLIAM FARNUM, the star in "Samson," by Henri Bernstein, a William Fox Production Extraordinary, released through the Box Office Attractions Company, is called upon to exercise prodigious feats of strength in the leading role.

In the big scene of the play, Brachard (Samson) invites Govain, a duelist and libertine, who glories in his intrigues, to lunch at the Hotel Ritz. Brachard knows that Govain has taken his (Brachard's) wife to an orgy the night before, and that Mme. Brachard has escaped from the scene with a torn dress and hand cut by a broken champagne glass. Brachard, who from a dock-hand has risen to a power of finance, controls the copper market absolutely.

Govain accepts Brachard's invitation, never dreaming that the copper-king knows

"HALF THE EXHIBITORS DON'T KNOW WHAT THE OTHER HALF IS DOING"

was true—

BEFORE "MOTION PICTURE NEWS" CAME.

of the visit of his wife to the Cafe de Paris. Brachard, having trapped him, locks the door and raises his sledge hammer fists, hardened by his early years of toil. Govain screams and threatens. But it is no use.

Like a terrier shaking a rat Brachard pulls Govain from his feet and smashes him with a blow of his fist across a table. Then, after administering a terrible physical punishment to the man who has robbed him of his wife, Brachard flings Govain out of the room and kicks his hat after him.

When this scene was played at the William Fox studios in Jersey City, everybody who knew of Mr. Farnum's physical prowess, and the way in which he throws himself into a part, gathered round the "set" in which the punishment of Govain was to take place, for they guessed it would be a pretty strenuous scene. The scene opened quietly enough, but as it progressed Mr. Farnum grew white about the nostrils. His hands clenched and unclenched. These were danger signals to the initiated. Suddenly Mr. Farnum made a dash at Govain, played by Charles Guthrie, who is tall and slender. Picking him up by the throat he swung him round his head like a human dumb-bell and then smashed him down on the table with a force that burst it in two and snapped its legs.

Guthrie, black in the face from the actor's

choking grip, gasped and gesticulated. With a final swing of his arms Mr. Farnum hurled Govain clear across the studio and out of the door of the set. Mr. Guthrie was so exhausted that restoratives had to be given him and nobody was more solicitous for his welfare than Mr. Farnum, who expressed his regret that he had been so carried away by the action of the scene.

FIRE AUTHORITIES AFTER FILM EXCHANGES IN SYRACUSE

Special to MOTION PICTURE NEWS

Syracuse, N. Y., Dec. 23.

THE Picture Playhouse Film Company, The Eclectic, The Box Office Attractions, The Greater New York Film Rental Company, Warner's Features, The General Film Company and the Western Film Exchange may all be without homes in Syracuse very shortly if the threatened action of ejecting these exchanges is carried out by the city authorities.

The first five named exchanges are located in the Eckel Theatre building and the owners have had their insurance boosted 60 per cent., and all insurance has been cancelled on the remaining tenants until the films are removed. The city authorities claim that the exchanges are a menace to the building, and that they must move outside of the first fire zone. The Eckel Theatre is located in the same building, making matters doubly worse. Exchanges have been notified to be prepared to move on short notice, and things look bad.

All the feature people are getting together in an effort to secure a central location near the express offices and depots, and are meeting with some success, assisted by the chamber of commerce.

PARAMOUNT'S NEW PICTORIAL

The first number of *Paramount Magazine* makes its initial appearance with the Christmas number and gives promise of being of great value to the Paramount exhibitors from a box office standpoint.

The forerunner of the publication has furnished the exhibits under the name of "Paramount Progress," and was intended for distribution among the patrons of the theatres. The new releases are mentioned at length in the magazine, and in addition other interesting items dealing with screen folks. The latest innovation is a page headed "My Lady's Boudoir." Beautiful illustrations of film players and scenes from Paramount pictures are scattered through the magazine.

BOY ACTOR IN EIGHTH "ZUDORA" EPISODE

Donald Gallagher is a newcomer to the Mutual program. He is one of the most famous boy actors, and is to make his initial appearance for Thanhouser in the eighth episode of "Zudora."

In the past he has distinguished himself in plays with such celebrities of the stage as Sol Smith-Russell, Maxine Elliott, Eleanor Robson, Arnold Daly, Dustin Farnum and H. B. Warner.

ROMAINE FIELDING, AUTHOR, DIRECTOR, MANAGER

Romaine Fielding, of the Lubin company, holds a unique position in the film world, though his position is hardly more unique than the man himself. We have author-actor directors, but the Lubin's star is the only one who can attach "manager" to this array of titles. And Mr. Fielding is manager of his company.

It was three years or so ago that Mr.



ROMAINE FIELDING

Fielding entered the motion picture ranks as an actor for the Solax company in Fort Lee, N. J. But the versatility of the man did not permit him to remain there long. He desired to branch out and, it seems, the company refused to let him branch. He left, after an affiliation of sixty days, to become a leading man with the Lubin company, at Nogales, New Mexico.

And here he found his opportunity; in about six months' time he became director and author of the plays that were being produced down there, besides playing the leading male roles. Soon after he was made managing-director with full power in the handling of the finances and the production of plays. Since then, his rise to popularity among the "fans" and esteem in the industry has been rapid and tremendous. He is at present producing several big features, some of them of five and six-reel length, out at the Lubin's farm, Betzwood.

ANNIE LUTHER HELPING "SWEET CHARITY"

Anna Luther has been a busy little girl the past week, with acting the part of the wife in "A Man's Shadow," which is being filmed for the Kinetophone, and selling penny lunch tickets in a daily paper's campaign for cheap lunches for school children.

Miss Luther has been spending her days in "reel" life as the mother of another's kiddie, and her evenings in real life selling tickets to help the kiddies of a thousand mothers.

NEW YEAR RESOLUTIONS

WILL SOON BE IN ORDER

A RESOLUTION
TO JOIN THE ARMY OF
MOTION PICTURE NEWS

SUBSCRIBERS WILL REPAY YOU A
THOUSAND TIMES OVER

Ask any Live-Wire Exhibitor if it's true

Did You Sign One?

(No. 63. Straight-from-the-Shoulder Talks by Carl Laemmle, President.)



I 'VE been hearing some interesting stories about the operations of some of the many get-rich-quick men who have been wedging their way into the moving picture business.

One of them deals with a smooth tongued individual who conceived the plan of getting exhibitors to sign a contract whereby they agree to book one of his so-called "features" every week for 52 weeks.

He got the exhibitors to sign the contracts on the strength of a very good picture which he showed them as a sample of the 52 he intended to make every year. So the poor duffers (are you one of them?) signed the contract!

The first picture, as I said before, was fine. But the second, third and fourth were rotten. The fifth was good, but the succeeding ones were junk. The exhibitor began to suspect that he had been stung, but he felt that he was hooked up for a year because of his contract, not realizing that the smooth-tongued fellow who hooked them had **ALREADY SMASHED THE CONTRACT TO PIECES** by misrepresenting his proposition and failing to deliver acceptable pictures.

But the really interesting feature is this: On the strength of the contracts which he had inveigled the exhibitors into signing, Mr. Smooth raised a fat and healthy bank roll. Did he put any of it into new pictures? Not at all. He salted

it. He got it by using the exhibitors as a tool. He sold stock on the strength of their signatures to contracts, and now he rolls around in automobiles and gives the exhibitors the merry laugh.

If you've been one of his victims it's your own fault. I've warned you so many, many times that I've worn out my warning apparatus.

If you'd only take the extra money that you now spend for "features" and spend it for newspaper advertising, you'd be building on a solid foundation and you'd get somewhere.

You're not wise to sign any contract for films unless you sign with a strong, reliable concern; one which has demonstrated its ability to make a good program **ALL THE TIME INSTEAD OF JUST FOR A WEEK OR TWO**; one which proves by its enormous investments in permanent equipment that it is **HERE TO STAY**. When you find a concern like that, sign as fast as you like so that no competitor can take your service away from you.

Personally I know of only one such concern in all the wide, wide world.

I refer to the concern which proved its faith in the future of this business by building **A WHOLE CITY** out West just to make pictures; the same concern which is now building, across the river from New York City, the largest glass studio in America. It's the Universal, of course!

CARL LAEMMLE.

Accessory News

A SECTION OF MOTION PICTURE NEWS DEVOTED TO THE
CONSTRUCTION, EQUIPMENT AND OPERATION OF THE MODERN PICTURE THEATRE

"IMITATION IS THE SINCEREST FORM OF FLATTERY"

As manufacturers of Mirroide, the flexible, metalized glass screen, we feel flattered that there are on the market at the present time the "Just as Good" or "Better than Mirroide" imitators.

The counterfeiter cannot last, and to those whom they may succeed in selling (?), we eventually replace with a Mirroide. **But You Cannot Afford To Take Chances.**

Competition has made it necessary for you to have the best at all times. In the screen line, **that best is Mirroide.** You can prove this statement by sending for large, free samples. Test, use your eyes, and common sense.

Would the new Elsmere Theatre, New York City; the new Englewood Theatre, Englewood, N. J., and the 8,000 other satisfied users of Mirroide install and **keep** Mirroide, if Mirroide did not "Have the Goods"? Most Emphatically **NO!** The Starland Theatre Circuit, Winnipeg, Canada, to whom we sold Mirroide when we started in business, 6 years ago, still continue sending in orders. **WHY?** Write Them! The above facts should convince you that **Mirroide Is The Screen for You.** Now—Use the Brains God Gave You.

"SEEING IS BELIEVING"

3 TINTS
Silver White
Silver Flesh
Pale Gold

2 SURFACES
Grade A, Fine }
Grade B, Rough } Matte

Made by

J. H. GENTER COMPANY, Inc., Newburgh, N. Y.

Manufactured Under Patents Allowed to J. H. Genter

Projection

CONDUCTED BY HERBERT W. ANDEM

Continuous Performances Possible With Ingenious Auto Rewind Machine

F. E. FREDERICKS, of Port Clinton, Ohio, has recently given a demonstration of his auto-rewind machine in New York. This enables an exhibitor to give a continuous performance. It does away entirely with re-threading of the machine at the end of each reel and the necessity of rewinding after each show. It also makes it possible for one man to handle the projection booth, as but one machine is used with the outfit.

The first reel of the show is placed in the box as reel S in the drawing. This film is sent through the machine till the entire show is wound on reel B, A being empty.

Clamp U on reel A is then snapped down in place on the film, and the reel starts to revolve, one part of the film winding directly from reel B, and the other passing through the projection machine, around post Y, also winding on reel A.

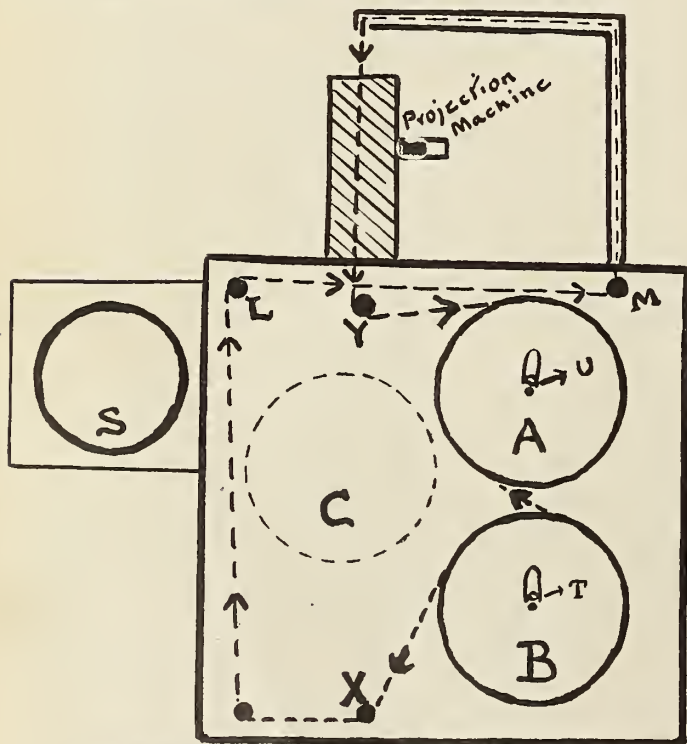

CROSS-SECTION OF THE AUTO REWIND MACHINE

As shown in the drawing, the film runs from B directly to reel A, and also at the same time around post X up to post L, across to post M, up through the inverted "L" and down through the projection part of the machine around post Y, winding on reel A. This makes a continuous chain of film without a break.

Action of the Reels

As soon as reel A is full and reel B empty, clamp T is lifted and reel B automatically rises, taking the position of reel C. A then falls into the position formerly held by B. B taking the place of A, the clamp falling into place, holding the film tightly, the reel immediately starting to revolve, taking on the film from B and also from the machine.

When the films are to be changed it is cut at the beginning of the reel, run around post Y and onto the small reel S. When this

is full, it is cut, another reel put in place of S, 'till all the reels are found off the machine.

The photograph shows reel A filled and falling into the place of B, which is moving into position, C ready to snap into the place just left vacant by A.

This should give the reader an idea of the mechanical end of the machine.

The box holding the reels is made of sheet iron with an exhaust

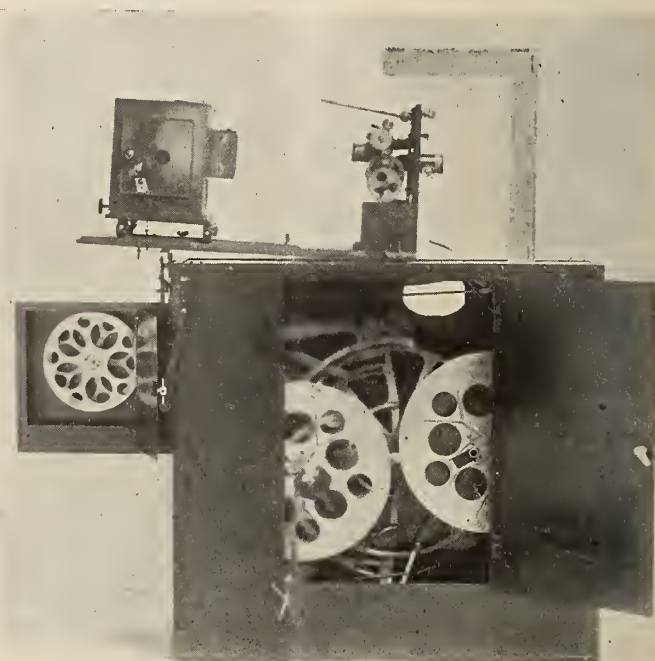

THE FREDERICKS AUTO-REWIND MACHINE

pipe, the view of which is shown in the photograph. The only part of the film, therefore, not in an absolutely fireproof iron box is that passing directly through the machine—an important thing to remember.

There are at the present time several of these machines in use which are proving most successful.

A Remedy for Overheated Motors

C. R. M., Montgomery, Ala.—We are using motor-driven projectors, and one of the motors is not working just right. Direct current is used and the motor soon becomes quite hot all over. Can you suggest any cause for this? This difficulty has caused me considerable anxiety.

ANSWER.—When a motor becomes hot all over, several conditions can be attributed to this heating. It is not safe to predict any part found hot as being the seat of trouble. By feeling all over, the part found to be the *hottest* may be taken to be the seat of trouble, or very near to it. A safer way to locate the seat of trouble is to allow the motor to become thoroughly cool. Then start up and run for a short time. Then feel around and find whether the shaft, bearings, brushes, commutator, armature or field windings heats first. There are so many causes for this general heating in small-sized motors, space will not permit discussion of them all as an aid to helping you out now. If you will follow the suggestion of locating the part that heats first, after the motor has been cooled off, then assistance can be given with more definite assurance of aiding you.

Announcement

This announcement to the exhibitor, theatre man and theatrical world, tells the story of an exhaustive, scientific and *PRACTICAL INVESTIGATION* made by the best and most complete corps of seating designers, construction engineers and manufacturing experts, ever associated since the theatre chair industry began.

After years of study on theatre chair usage these men, backed by the vast facilities and *MANUFACTURING ECONOMIES* of (*REALLY*) the largest and most *complete* theatre chair factory in existence, have now with their combined expert knowledge designed and constructed a complete line of chairs embodying a principle that no other theatre chair on the market has. This principle, which eliminates all theatre chair trouble, is the *LAST WORD* in chair construction.

As a result—*THOUSANDS OF DOLLARS'* worth of machinery will be *discarded*. More new machinery, dies and patterns together with a new building addition to our large plants are necessary for the manufacture of these chairs.

Before purchasing, *investigate* what has caused us to spend a fortune to get these results. Your purchase is sure to be:

**CAST
STEEL
THEATRE CHAIRS**

Our agents are *everywhere*. Write us and we will put you in touch with one.

WISCONSIN SEATING FACTORIES

"Capital Stock Paid in One Million Dollars"

NEW LONDON, WISC.

PORT WASHINGTON

GRAFTON

SHEBOYGAN

ADDRESS: Theatre Chair Sales Department, New London, Wisconsin

OPERA CHAIR AGENTS: *Very little territory left. Write us now.*

Directory of New Theatres

\$100,000 Terre Haute House In Operation

THE new American theatre at Terre Haute, Ind., which was built by the American Theatre Company, of Terre Haute, of which Maurice Less is the manager, at an approximate cost of \$100,000, and which opened Christmas eve, is one of the finest motion picture theatres in the State of Indiana. The policy of the house will be five, ten and fifteen cents. Parquet boxes will be reserved one hour for each performance in advance.

Special feature productions will be run.

The theatre was designed by Mr. Less, who made every effort to build it as near fireproof as possible, and it contains a large number of exits.

The theatre is in Wabash avenue and has a frontage of fifty feet in Wabash avenue and is 162 feet deep. It is two stories high and seats 1,050.

The balcony has a drop of twenty-five boxes on each side from the stage to the rear of the auditorium, which are convenient to the parquet floor. The seats in the boxes will be individual cane chairs, while the rest of the seats will be upholstered in leather. The boxes will seat eight and ten persons.

The two stairways leading from the foyer to the balcony are marble and all partitions in lobby and foyer are marble from the ceiling to the floor. A very novel idea is carried out in the lobby. Between the pilasters are flower boxes bedded in front of mirrors which are encased in panel frame with festoon hangings. A ten thousand-dollar pipe organ with an echo has been installed and a ten-piece orchestra will be used in connection. The screen is 14½ feet by 18½.

A woman's retiring room and a children's room are on the second floor while the men's smoking room is in the basement. The lobby is twenty-two feet deep and leads into a foyer ten feet deep by forty-five feet long.

Suspended over the main entrance and studded with five hundred incandescent globes is a beautiful marquee. The theatre will be lighted by its own electric light plant and the interior will be profusely lighted and fittingly arranged with fancy and decorated chandeliers containing clusters of globes. The sidewalk, which is marble, extends the full length of the front of the theatre.

West Coast Theatre Concern Plans Expansion

THE recent success of the plans of the Turner & Dahnken Circuit for securing additional working capital for contemplated extensions to its circuit of moving picture houses has resulted in the incorporation of the Turner & Dahnken Controlling Co., with a capital stock of \$2,500,000. The incorporators are J. T. Turner, F. Dahnken, C. L. Langley, E. B. Johnson and J. A. Buck. This concern now conducts seven large houses located at San Francisco, Oakland, Berkeley, Alameda, Richmond, San Jose and Sacramento, and at an early date will open another at Watsonville.

It is planned to have a new house at Oakland within a year and preliminary arrangements are being made for entering new fields, with Los Angeles and Portland the first to receive attention. It is possible that this concern may also enter the producing business, but this step has not been decided upon.

Large Photo Play House Planned for Lexington

TENTATIVE plans for opening in Lexington another big motion picture theatre here have been practically completed. Louisville and Indianapolis motion picture theatre men and John D. Maguire, of that city, are promoting the enterprise which will be located in the Maguire Building at the northwest corner of Main street and Broadway. A long lease has been taken on the building

which is just now being remodeled with the intention of making it the most attractive movie house in the State, outside of Louisville. Plans for the complete remodeling of the building will be prepared by B. X. Murphy & Bro., Louisville architects.

One of the novel ideas to be incorporated in the new motion picture theatre is the doing away with stationary seats and installing round tables on the main floor around which four chairs will be arranged so that patrons of the house may enjoy a lunch or fountain drinks while witnessing the performance. It is stated that houses with this feature are popular in New York and Paris and it is the intention to copy the idea as carried out in these cities.

Theatres Here and There

EDWARD J. BUTTERMORE, of Scottsdale, Penn., has assumed the management of both the Olympic and the New Empire motion picture theatres in Connellsville, Pa. Mr. Buttermore was particularly successful with the theatrical and moving picture ventures in Scottsdale and brings to his new position the fruits of 10 years' experience.

The fronts of both the Pittsburgh street houses are being remodeled and when this work is completed they will compare with any in town.

Mr. Buttermore is negotiating for exclusive rights to some of the best films produced.

A new motion picture theatre, embodying in architectural design, features entirely original in the South, is to be opened at 1501 Elm street, Dallas, Tex., about the latter part of January. P. G. Cameron has secured a long lease on the property which is owned by the Drake estate, and will expend between \$20,000 and \$25,000 in improvements. The location is just east of Akard street, on the south side of Elm, and Architect I. A. Walker has already completed the plans.

The entire dimensions of the theatre will be about 25 x 100 feet, and it will have a seating capacity of 400 or more.

Nicholas Carries has leased a moving picture theatre in Ossining, N. Y. Mr. Carries has taken possession of the picture house. The theatre is one of the largest in Ossining and seats nearly 1,000 people. The lease is to run for five years. Mr. Carries owns a chain of shoe shining parlors in Beacon, Newburgh and Poughkeepsie.

Hagel Bros. are making progress on the new McClintick Theatre they are erecting in the 3100 block South Adams street, Peoria, Ill. It will be strictly modern and up-to-date in every way.

Films Arrive Before Theatre Is Finished

In order to have the building completed by the opening of the Exposition, a night shift of eighteen men is working on the construction of the new Cabrillo Theatre, San Diego, Cal. Manager R. E. Hicks, of the Plaza Company, which will control the Cabrillo, had intended having the theatre in operation November 1, but the delay in construction prevented him doing so. The equipment for the Cabrillo and even the films to be shown have been arriving daily, Hicks having made complete arrangements for the opening.

The films have been returned, but the electrical apparatus, photoplayer, seats, and ventilation system are now stored ready for use as soon as the building is completed.

Day and night shifts will be employed and work rushed until the theatre is ready for occupancy.

The name of the Star theatre, Bangor, Me., is to be changed to the Park Theatre, under its new management, The Bangor Amusement Co., Stephen Boggett, local director. Alterations and improvements are now in progress and the house will be opened about January 1 with high class photoplays.

Milford, Mass., is to have another moving picture place in the upper story of the new \$10,000 block which G. Iadale is erecting on East Main street, and for which Architect Frank Hughes drew the plans.

There is to be a large hall in the building, and it will be fitted for another home for the films according to present plans.

The new Franklin Park Theatre, Blue Hill avenue, at the junction of Columbia road, Boston, Mass., was opened last week. The house has a seating capacity of nearly 2,000, including four boxes.

The interior decorations are of a soft colonial gray and gold, with panelings of tapestry rose, with a decorated ceiling in ivory white and gold, with classic moldings.

The opening attraction was Mary Pickford in "Behind the Scenes." There were other Paramount films with the "Famous Players" appearing and a bill of vaudeville. Recitals on a large organ was another pleasing feature of the entertainment.

There will be performances afternoon and evening, with a change of bill twice a week. Sunday evenings there will be a special program.

Theatres in the South and West

Arrangements are being made for improvements to the Elm Theatre, Greensboro, N. C., which is under the direction of Mr. Wilkerson, manager of the Piedmont Theatre. Direct current will be furnished and an expensive curtain installed for the showing of the films which will enable the management to show the finest pictures made.

The new Metropolitan motion picture house in Eau Claire, Wis., was opened recently. The theatre is in the Metropolitan building and is fully equipped as an up-to-date film house.

The entrance is attractive in maroon stucco with white ornamental designs. The interior walls are in delicate tints of old rose. The seats and other furnishings are all new and complete.

The sixth motion picture play-house in Charlotte, N. C., has just been opened by J. J. Richards, a former resident of Charlotte, who has been making his home in San Francisco for the past two years. Mr. Richards returned to Charlotte some weeks ago and began at once plans for engaging suitable quarters for the picture house. He has secured the space in the Central Hotel building formerly occupied by Graham's and being used for a display of Oriental rugs. It ranks with any in the city for convenience and size and the manager proposes to make of it a first-class amusement place.

Sales and Openings

The Ideal Theatre, located on Eighth avenue, between Twelfth and Thirteenth streets, Altoona, Pa., and one of the city's leading moving picture houses, has been sold by Edward Young, the real estate dealer, who first started it, to C. L. Koeler of Altoona, owner of a moving picture theatre at Hollidaysburg and one in Pittsburgh. The new owner will take immediate charge.

A new moving picture theatre, the Duchess, has been opened in Warren, Ohio. It compares favorably in size with the largest in Youngstown, and is notable for its decorations and furnishings. These were in charge of Samuel W. Rice and associates of Youngstown.

T. W. Smith has bought out the moving picture show business of A. Z. Danes in Danville, Ill., and has installed a new electric machine. The show is now in operation.

William Bosse, who has announced his intention of converting his store building at 20 Mechanic street, Spencer, Mass., into a moving picture theatre, received a visit from the state inspector of buildings Tuesday. The plans for the theatre, drawn by R. B. Stone & Co., were approved. Mr. Bosse says the seating capacity will reach about 275.

An ornamental front with lobby will be constructed and the floor dropped down at angle. He expects to commence work immediately.

Big House in Jacksonville

A building permit has been secured by the Southern Investment and Amusement Company for the construction of a \$60,000 theatre in Jacksonville, Fla. The new playhouse will be located on the south side of Adams street between Main and Laura streets. The company hopes to make this the finest motion picture house in this section of the country but the plans are drawn so that the theatre can be converted into a vaudeville house within twelve hours.

The north side of the building, fronting Adams street, will be two stories high. The lower floor will be divided into stores and the upper floor will contain offices. The entire building will be 102 feet by 101 feet. The theatre proper will be 70 feet wide by 101 feet long and the house will seat 1,200 people, 800 on the lower floor and 400 in the balcony.

The stage will be at the east end of the building. It is to be

MENGER & RING

302
W. 42nd
Street
New York

TELEPHONE
BRYANT 6621



FURNITURE & FURNISHINGS

On RENTAL
We equip your settings complete in accordance with your scenario.
WILLIAM BIRNS
103-105 West 37th St.
Phone: Greeley 6255.

ROLL TICKETS Specially Printed and Absolutely Guaranteed

Cash with order. No C.O.D. at these prices.
50,000 for \$5.40 200,000 for \$15.30
30,000 for 4.50 100,000 for 9.00
Write for Samples and Prices on Other Quantities.
Rees Ticket Co., 400 So. 10th St., Omaha, Neb.

PROJECTION PROBLEMS ANSWERED

Troubles are continually coming up in every booth. Why not see whether the other fellow can help you? Our projection expert is ready and willing to answer any and all questions

WHICH YOU MAY ASK

Without obligation on my part please give me full advice on the following:

Name
Theatre
Address

Make Your Lobby Display Attractive

There is nothing more fascinating to the public than a bright brass frame to display your photos or posters.

We make Lobby and Theatre Fixtures and Brass Rails of every description.

Don't fail to visit our Showrooms. Write for catalog.

THE NEWMAN MFG. CO.
 717 Sycamore St., Cincinnati, Ohio
 Branch Factories and Show Rooms:
 101 Fourth Ave., New York, N. Y.
 106-108 W. Lake St., Chicago, Ill.
 Established 1882.

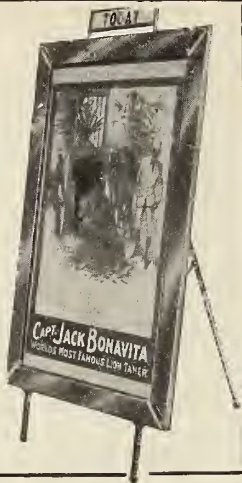

We Can Equip Your Theatre Complete

We are Distributors for the Powers, Edison, Motiograph and Simplex Machines, and Genuine parts, also Poster Frames, Indirect and Semi-Indirect Lighting Fixtures, Tickets, Screens, etc.

We sell for cash or on the easy payment plan. Write today for our new catalog just off the press.

AMUSEMENT SUPPLY CO.

160 No. Fifth Avenue Chicago, Illinois

ACCESSORY AID

We stand always ready and willing to help all our readers in making their purchases. We buy nothing but we will tell you where your needs can be supplied to

YOUR BEST ADVANTAGE

Without obligation on my part please tell me where I may purchase the following:

.....
 Name

.....
 Theatre

.....
 Address

constructed on a large scale with asbestos curtain and dressing rooms. The most modern plans for heating and ventilation will be installed. The Jacksonville Construction Company has the contract for the erection of the new theatre. Work has already begun and will be rushed to completion as fast as possible.

Latest changes in Detroit theatres are the appointment of Sam Johnson as assistant manager of the New Empire, and W. G. Kaliska, as manager of the Royal and Casino theatres. Mr. Johnson has been operator at the Empire for over a year, while Mr. Kaliska comes to Detroit from Buffalo, N. Y., where he has been manager of the Allendale Theatre for nearly a year.

New Arbor, Detroit, In Operation

The new Arbor Theatre, at Woodward and Harper avenues, Detroit, Mich., opened Saturday afternoon, December 12. The theatre will accommodate 400 people, and is 40 by 75 feet in size. Alvan D. Hirsch is the proprietor, who is acting as manager. He plans to give his patrons a change of program every day, with features at least twice a week. The theatre has been attractively decorated in arbor style. On the stage is a Masterlite screen, and in the operating room a Powers 6A machine. Matinees will be given on Saturdays, Sundays and holidays, and every evening. This is Mr. Hirsch's first venture in the moving picture industry. He is an attorney by profession, and an enthusiast about the "movie" business.

Thomas Peterson will open a new moving picture theatre in Scottsville, Mich., about December 25.

The Vinewood Theatre, formerly owned by Barry & Dietz, real estate dealers, Detroit, Mich., has been transferred to Mrs. Fanny Rodger. The theatre is located on Michigan avenue, near Vinewood avenue.

A new theatre is being built at 235 Michigan avenue, Detroit, Mich., which will be ready about holiday time. It is owned by Lathan Bros.

The theatres owned by John H. Kunsy in Detroit, Mich., and formerly operated under the style of the Casino Amusement Company are now operating under the name of John H. Kunsy, Inc. The list comprises the Casino, Royal, Liberty, Empress, Washington, Garden, Columbia and Alhambra.

The Academy of Music, Saginaw, Mich., starting December 20, is playing pictures. Only big features will be shown. New apparatus has been installed in the operating room, which is separated from the remainder of the theatre by a brick wall. Under the co-operation plan admissions to the Academy is ten cents, and with each ticket a coupon is given which is good for 10 cents at the Jeffers (also owned by Mr. Ruscoe) or for an admission to the Bijou. With each ticket purchased to the Jeffers and Bijou will be given a coupon worth five cents at the Academy for the picture shows.

New theatres to open in Detroit, Mich., the current month are the Virginia Park, the Maxime, the Rosedale, the William Penn, the Arbor, and 235 Michigan avenue.

The Imperial Theatre in Beaver avenue, North Side, Pittsburgh, has changed hands. It was bought by Carle Carlton, owner of several other theatres in this section. The new owner of the theatre will in the future use nothing but feature films. At present he is using Paramount service.

Shelbyville, Ind., soon will have a new motion picture theatre. A two-story brick structure to cost \$10,000 will be erected by the Dorsey heirs and will be leased for ten years by William C. Meloy.

The new motion picture theatre being constructed on Maryland avenue, near Bird street, Wilmington, Del., has been named the "Polonial." The new building is being erected by a number of influential Polish residents of that section and it is expected to open the place by Christmas.

F. E. Millikin has received a building permit to erect a \$10,000 picture house at the corner of Center street and Wilson avenue, Youngstown, Ohio. The building now on this site will be remodeled. The new theatre will be modern in every way and the front vestibule will be finished in an elaborate way with a marquee over the sidewalk. It will be built strictly in accord with the state code and the building code of Youngstown. The show house will be constructed of brick.

Bids have been submitted on plans for the proposed business block and moving picture theatre to be built on Dixwell avenue, near Webster street, New Haven, Conn., for Daniel P. Brown, 17 Hillhouse avenue. It is expected that the contract will be let at once. The structure will be 32 x 141 feet, one-story high, of brick with a gravel roof. It will be arranged for two stores and a theatre in the rear, having a seating capacity of 550.

Music and the Picture

Editor's Note.—This department is prepared to answer all questions from exhibitors relating to the use of music in connection with photoplays, and to suggest suitable music for current pictures. Correspondence will be welcomed

CONDUCTED BY H. S. FULD

Using Judgment in Playing to Pictures

By E. A. Ahern

A FEW weeks ago I visited one of our large cities of the west, attending nearly all of the picture theatres.

My intentions were to learn what kind of music they used in the large cities, and especially in the up-to-date picture theatres.

Right now I want to say I was greatly disappointed, not with the music itself, but the way it was rendered as an accompaniment for the pictures.

The first house I visited is one of the largest in the west and employs an orchestra of eighteen pieces and a pipe organ.

They were showing a two reel Selig comedy, "A Moving Picture Cowboy." It was lively all the way through.

The organist was playing some gavotte and later on a classic selection.

I was so taken up with the organ that I forgot what the comedy was about.

The music was great, but one either had to listen to the music or forget it, and look at the pictures. For neither was connected.

Used "Heavy Overture"

The next picture was a Biograph. The orchestra played for this picture, using a heavy overture.

Now I have read a great deal about orchestras that end a selection by having the drummer use a crash cymbal, but this was the first one I have ever heard, and this orchestra did this very thing.

The picture was very pathetic, showing the death of a sweetheart and then the body in the coffin.

Just when the mourners gathered around the corpse the music stopped with the loud, brassy tone. When this happened I lost my admiration for that orchestra. The picture lasted about five minutes before the end of the reel. I sat and waited for some music that would help bring out the solemnity of the picture, but the musicians had come to the end of the music, therefore I had to wait for another picture to be thrown on the screen.

Lack of Judgment

I did not go to that theatre to hear anything like this. A person can hear "music" of that kind in any theatre where there is an electric piano.

What I expected to hear was music that was in keeping with the picture, but, as I said, I was greatly disappointed.

If they had played the overture for the comedy and the organ for the pathetic picture, the music would have been more in keeping with the pictures.

I dropped into the same theatre the next day to see "Uncle Tom's Cabin."

In all of the five reels there was not one southern melody played. The pipe organ was the only instrument used, as the orchestra only played from 2 o'clock on.

To tell the truth I do not know why the organist did not use some southern music for this picture; nearly anyone that had an idea of music would have done so. This party played "Humoresque" and music of that nature; so you can readily see how it fitted the picture.

The next house I went to was a five cent theatre that employed a small sized band. They actually played so loud that I saw one reel through and then left.

There is another theatre like the first that has a pipe organ only. The picture being shown was supposed to have been taken

on a South Sea Island among the cannibals. The "engineer" at the organ had put on the "Poet and Peasant" roll. It was another case of poor judgment; also poor advertising for the house.

Music No Help to Picture

Now, mind you, all these were first class houses and the people employed in the orchestras were musicians in every sense of the word. I am not criticizing in any way these people in regards to their playing. I am just giving you an idea of the fitness of the music to the picture.

I also attended the smaller theatres, hoping to find some one that actually played for the pictures. Out of the eight or nine shows I visited there was not one where the music was in any way a help to the picture.

There is one thing I wish to mention. I did not hear a good "rag" or a popular air in any of the houses. The only place I did enjoy the music was at a vaudeville house.

Do not infer that I do not appreciate the other class of music, for I do. But let us have it where it belongs. I was told by a party in that city that none of the orchestra leaders ever attempted to play a popular song hit. I do not believe it would hurt any musician's reputation to just play one during a show. Give the patrons a little variety. I think it would be just as much appreciated as heavy "music."

If the manager of a house sees fit to put on a slap stick comedy, I think a little snappy music would not hurt the house's standing. This is where a number of musicians are mistaken about the "rag" music. If a picture has lots of "go" in it, what is the use of holding back the action with slow music.

Classics Not Wanted

They would probably say: "Let's have some selection from Wagner or Chopin played for the picture." All right; the orchestra I was just speaking about played on this order, yet these very same people would be dissatisfied without knowing why.

There is only one way I can see how musicians can get around this proposition, and that is to play music that has the atmosphere. Why should one play the "Overture Raymond" for a western picture, or "William Tell" for a southern story.

Take, for instance, "Uncle Tom's Cabin." If the organist had played "My Old Kentucky Home" it would have been more pleasing to the ear than the "Humoresque" even though it is not considered as great a piece of music. Difficult music does not always leave as good an impression on the patrons as simple melodies.

To illustrate: The other evening I showed "Strongheart." For the last part of the last reel I played the "Sun Dance" on the organ (an old parlor organ) when the Indian comes in to take Strongheart back to the reservation.

This may seem queer Indian music on an organ. I did try to get the tom-tom effect with the left hand, but just held down the chord. The melody was weird and at the same time pathetic. I had the tremolo stop out, which also made it more solemn and played very adagio.

This picture was the talk of the town for a couple of days afterward. Every person that saw it was enthusiastic over it. Why! Because I played so masterly? No. It was because the music was in keeping with the picture, nothing but a simple Indian dance. But it did the work.

Make your audience feel as though they were actually on the ground where the picture was taken, but you cannot do it unless you play this kind of music. If you have a simple story to help unfold the plot use simple music.

MOVING PICTURE THEATRE MAILING LISTS FOR SALE

20,192, covering United States and Canada, Price \$40.00, or \$3.50 per thousand for such states as you want.

- 795 Film Exchanges, U. S.\$3.50
- 70 Manufacturers and Studios, U. S..... 1.00
- 34 Moving Picture Machine Mfrs. and Dealers..... 1.00
- 231 Film Exchanges, Foreign Countries..... 3.00
- 520 Moving Picture Theatres, Foreign Countries.... 3.00

Ask us for full particulars.

TRADE CIRCULAR ADDRESSING CO.

166 West Adams Street, Chicago
Established 1880

PERFECT DEVELOPING AND PRINTING

For Amateurs and Professionals in any Quantities.
WE GUARANTEE QUALITY PLUS PROMPT DELIVERY AND PERSONAL SERVICE.

Prices, References and Factory Description Sent at Your Request

INDUSTRIAL MOVING PICTURE COMPANY
223-233 West Erie Street, Chicago

Our Factory Is Yours!

Negative assemblers, projecting machines and an equipment second to none, with an organization of experienced people always at your SERVICE for DEVELOPING and PRINTING.

EVANS FILM MFG. CO.

Incorporated

416-22 WEST 216th STREET
Tel. 6881-6882 Audubon at Broadway, New York

Motion Picture Studio Location

Ten acres in Pasadena, 1 1/4 miles from the City Hall, ten minutes to Orange Grove avenue. A fine location at a bargain price. See owner—

HARRY SHLAUDEMAN

502 Chamber of Commerce Bldg., Pasadena, California.

HERE IT IS

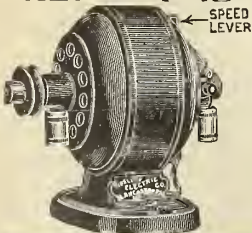

MOTORS FOR MOVING PICTURE MACHINES
110-60 Alternating Current \$14.00
110 Volts Direct Current \$12.00

Furnished complete with speed lever giving a speed range of 50%. Immediate delivery for cash with order.
Fidelity Electric Co., Lancaster, Pa.
WE MAKE MOTOR-GENERATOR SETS

PLAYER SLIDES

Most Beautiful \$1.75 per dozen
NIAGARA SLIDE CO., Lockport, N. Y.

CLASSIFIED

FILMS FOR SALE

500 Single Reel Subjects, all popular makes, comedies, dramas, etc., with and split reels, in A1 condition. J. B. O. Feature Film Service, American Theatre Bldg., Milwaukee, Wisconsin.

CAMERAS FOR SALE

2 Moving Picture Cameras, complete with Lenses and Tripod, Perforator and Printer. Will sell cheap. J. B. Olinger, American Theatre, Milwaukee, Wis.

HELP WANTED

Local representative in each State to handle exclusive State Right Features on percentage basis; bond required. J. B. O. Feature Film Service, American Theatre Building, Milwaukee, Wis.

BUSINESS OPPORTUNITIES

A New York Film Company owning excellent money-making five-reel feature, with subject that is world-wide, fine posters and photographs, desires representative in every State to handle on percentage agreement. Must furnish bond and \$150 cash, references as to film business ability and financial standing. Exceptional opportunity for hustlers of the right sort. M. N. Ford, Rm. 504, 43 Cedar St., N. Y. City.

SONG SLIDES and WAR SLIDES

For Sale or for Rent
NOVELTY SLIDE CO.
67 W. 23rd St. New York

DON'T POLISH YOUR BRASS WORK!

Apply a coat of NEWMAN'S Transparent Lacquer. Keeps brass bright for year without polishing. Bottle size, with brush, \$1.00
NEWMAN LACQUER COMPANY,
3346 Bonaparte Avenue, Cincinnati—Ohio.

New Theatres in the Gulf States

E. M. TUCKER has opened a new theatre on South Collins street, Plant City, Fla., in one of the new buildings lately completed, and has installed a \$3,000 Seebing player piano. The name of the new picture show will be selected by the public, in a voting contest.

The Pekin theatre at 813 East Washington street, Springfield, Ill., was opened to the public a few days ago. The theatre is just completed and is one of the most beautiful in central Illinois. L. Silver, an experienced showman, will manage the house.

The building permit for the erection of Montgomery's new theatre, the Arcade, on Adams street, Jacksonville, Fla., was issued, placing the value of the structure at \$60,000. When completed it is said that the theatre will be one of the handsomest in the South.

The Jacksonville Contracting Company is erecting the building for the Southern Amusement and Investment Company, and already the ground has been cleared.

A new motion picture theatre is under way in Geneva, N. Y., on which it is proposed to spend \$50,000. Leon Lempert, of Rochester, is preparing the plans. It is said the theatre will be managed by E. D. DeGraff, of Scranton, who owns a chain of picture theatres. The house will have a seating capacity of 1,500.

New Theatre Planned in Austin, Texas

The property at 713 Congress avenue, Austin, Texas, is to be the site of a modern theatre. The plans will be ready and the contract let in time to start work on the theatre the latter part of December or the first of January.

The H. & M. Amusement Company, of Brockton, Mass., is a new corporation formed for the promotion of public amusements in the state. A new moving picture house was opened Saturday in Worcester under the auspices of the company. President John W. Huff and the directors, M. R. Bassett and Russell G. Ryder, say they may open a moving picture house in this city during the winter.

At the expiration of the contract December 1, with Prof. A. W. Allen, the motion picture show which has been conducted by him in the Perley Hall, Enosburg Falls, Vt., for some time, was taken over by J. A. Browley and I. A. Vincent.

S. N. Robertson has sold his moving picture theatre at Lancaster, N. H., to his uncle, William Robertson, and has gone to Lodi, Wis.

Fire Delays Marketing of Edison Projection Machine

IT is fortunate that the disastrous fire at the Edison plant did not destroy the negatives and prints of the coming releases. However, there is another loss which will be felt by the trade in general in the form of complete destruction of the manufacturing plant where the new projection machine was being built.

It was intended that this should be put on the market within a short time, but L. C. McChesney, of the Edison Company, makes the statement that it will be three months anyway before this machine is available for distribution, as it will be necessary to make new dies and reconstruct the other manufacturing equipment.

Howell-Ryder Company of Chicago Moves

THE Howell-Ryder Company, formerly known to the trade as the Howell Sales Company, have moved to larger offices, Suite 711, in the First National Bank Building, Chicago.

This year they intend to carry cameras and full studio equipment, in addition to projection machines and accessories for the operating booth, and will make a specialty of giving expert advice upon all subjects of projection.

Both F. W. Howell and C. W. Ryder are well known in motion picture circles, having been identified with the industry in this section of the country for a great many years.

Fire Destroys Peninsula Theatre, Frisco

A DISASTROUS fire occurred in the building occupied by the Peninsula Theatre on Mission street, San Francisco, last week, resulting in almost a total loss to both structure and contents. The building was owned by T. Strum and the theatre was conducted under the management of Chas. Harding. It has not been decided as yet whether the theatre will be rebuilt or not.

Have you seen a copy of this week's Universal Weekly?—

We want every live Exhibitor in America to see this week's edition of the Universal Weekly which contains the most remarkable poster ever conceived and executed by The Morgan Lithograph Co. of Cleveland, Ohio. This poster in question is a 24 sheet stand made especially for The Universal Film Manufacturing Co., of 1600 Broadway, New York. This great poster has already been plastered all over the boards in the City of New York and thousands of people are staring at in wonder and amazement. To quote one Exhibitor who saw this poster the other day—he says—"Never saw a poster like it in all my life."

Talk about a crazy quilt design—talk about colors—Well, Gentlemen, the one and only way in the world to appreciate what a smash this marvellous poster is—is to send to The Morgan Lithograph Co., Cleveland, Ohio, for a sample. If it doesn't make you stare in wonder, then we are mighty poor dopesters. When we saw this poster completed we believed that the Universal Film Mfg. Co. would ask us if we were "plum crazy,"—but when it was put on the billboards and riveted the attention of hundreds of thousands of people—and caused no end of comment—we knew we had put out a tremendous winner.

This is the kind of a poster that has the genuine "punch" in it. It will actually kill any other poster within a half a block of it. It is so absolutely unique in coloring—in design—and idea and general character as to make any other 24 sheet stand look silly alongside of it. It is NOT the usual type of poster. You may call it allegorical, ancient—modern—advanced, or anything you fancy—yet it stands as the biggest smash we have ever known. The Morgan Lithograph Co., of Cleveland, Ohio, conceived and executed this poster. It is the talk of the country. Write us and we will send you a sample; also we will tell you more about this poster question. It means much to you. Write The Morgan Lithograph Co., Cleveland, Ohio.

PARAMOUNT



PICTURES

BOSWORTH
INC.

PRESENTS

MAGLYN ARBUCKLE

IN

"IT'S NO LAUGHING MATTER"



THE STORY OF
HI. JUDD
POSTMASTER AND
POET

WRITTEN & DIRECTED
BY
LOIS WEBER

GOING OVER HIS HEAD

BOSWORTH
INC.

211 NORTH OCCIDENTAL BVD
LOS ANGELES, CALIF.

220 WEST 42ND STREET
NEW YORK, N.Y.

BOSWORTH
INC.



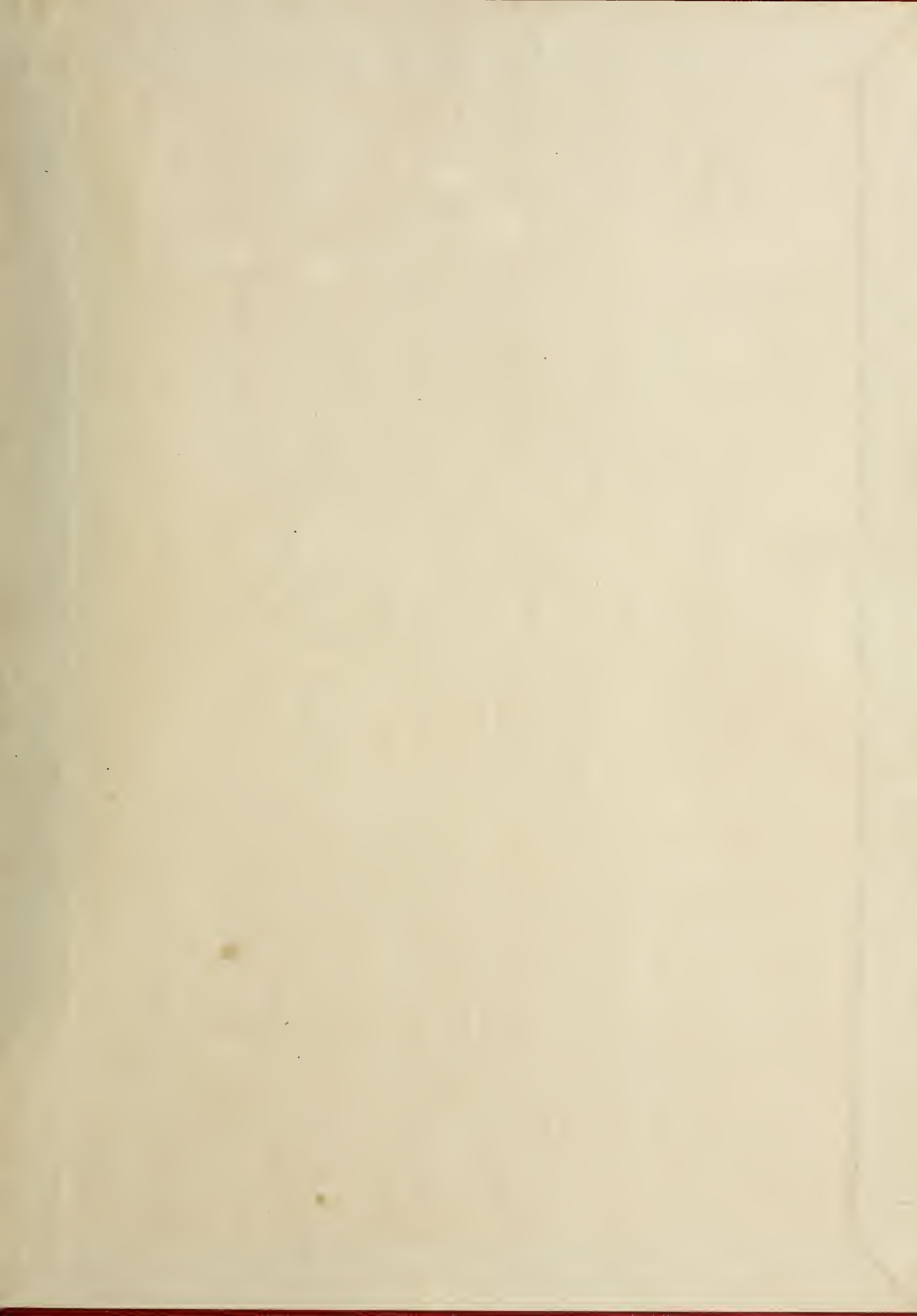

LIBRARY OF CONGRESS



0 007 551 491 8