



HARVARD UNIVERSITY.



LIBRARY

OF THE

MUSEUM OF COMPARATIVE ZOOLOGY

55,773

BEQUEST OF

WILLIAM BREWSTER

December 4, 1920.

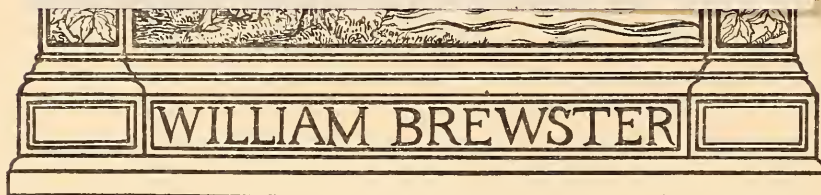

DEC 4 1920



LIBRARY  
RECREATION

A MONTHLY MAGAZINE DEVOTED TO EVERYTHING THE  
NAME IMPLIES

VOLUME XIX  
JULY TO DECEMBER, 1903

G. O. SHIELDS (Coquina), Editor and Manager

NEW YORK  
23 West 24th Street  
1903  
e,

LIBRARY  
W. W. COBBETT  
CAMBRIDGE MASS

COPYRIGHT, 1903, BY G. O. SHIELDS.

## INDEX TO VOLUME XIX.

	PAGE
Ben Doubled Him Up into a Wad and Sent Him Spinning.....	FRONTISPIECE
Ben; the Story of a Cub. Illustrated.....	W. H. WRIGHT 3
The Bread of Idleness. Illustrated.....	ROBERT P. LOWRY 15
Photographing in the Moro Country. Illustrated.....	GEO. D. RICE 17
A Place Just East of Persia. Poem.....	A. L. VERMILYA 18
The Hawk Bounty Question. Illustrated.....	J. E. TYLOR 19
With a Peeled Pole.....	FREDERIC BIGELOW 21
The Seagull. Poem.....	EDITH M. CHURCH 22
A Study of Feathers. Illustrated.....	MARY M. CALDWELL 24
W'y De Fish Don' Bite. Poem.....	EDWARD BONNEL 25
What Wouldn't I Give. Poem.....	A. N. KILGORE 27
The Jacana. Illustrated.....	L. P. GRAY 28
Pounding the Wrong Coon.....	W. H. NELSON 29
Montana Reminiscences.....	J. A. DUFFY 31
The Florida Kid. XI.....	CHARLEY APOPKA 33
A Day Off. Poem.....	EMMA G. CURTIS 34
The Truant. Poem.....	E. L. SABIN 42
The Bulls Stood Still and Gave Me a Chance for Another Shot.....	FRONTISPIECE
Hunting Blue Bulls in India. Illustrated.....	W. H. FEE 85
Loon Notes and Queries. Illustrated.....	ROBERT J. SIM 89
The Giant Brown Bears of Alaska. Illustrated.....	J. A. LORING 91
Tarpon Fishing at Pass Christian. Illustrated.....	M. SNOWDEN 95
A Tragedy. Poem.....	A. L. VERMILYA 96
An Interesting Summer Boarder. Illustrated.....	J. H. FISHER, JR. 97
In the Woods with Rod and Camera.....	F. W. HALSEY, M.D. 100
A Trip for Trout. Illustrated.....	DR. J. S. EMANS 103
Tenderfeet in the Grand Discharge.....	ROBERT FROTHINGHAM 107
Wild Sheep in Captivity. Illustrated.....	HARRY E. LEE 112
The Battle of the Prong Horns.....	W. T. HEDDON 113
He Was Uttering His Weird Call in Tones as Inspiring and as Musical as the Notes of a Flute.....	FRONTISPIECE
Hunting Elk in a Windfall. Illustrated.....	E. B. SHANKS 167
Some Feathered Folk. Illustrated.....	MARTHA M. WILLIAMS 171
A Deer Hunt in Mexico.....	J. K. EICHHORN 175
Rafting on the St. Joe. Illustrated.....	GEO. H. ROOT 177
Catching a Catfish. Illustrated.....	F. D. GREENE 181
Bob White. Poem.....	IRA SWEET 182
Quail Shooting in Kentucky.....	A. S. ATKINSON 183
A Leaf from the Log of the Rosamond. Illustrated.....	CHAS. VAN BRUNT, JR. 185
Among the Sandhills.....	JOHN McNEIL 187
Hadn't Lost Any Bear.....	BOYD C. PACKER 191
Jock o' the Gun. Poem.....	DOROTHY H. BARRON 192
A Florida Kid on a Camp Hunt. XII.....	CHARLEY APOPKA 193
Our Trophies.....	G. A. MACK 195
He Stopped, One Forefoot on the Fallen Trunk, One Reaching for the Ground Beyond....	FRONTISPIECE
My Dog Foss. Illustrated.....	GEORGE E. DODS 249
A Duck-Shooting Reminiscence.....	CAPT. E. L. MUNSON, U. S. A. 253
Antelope Hunting in Wyoming. Illustrated.....	E. C. HALL 255
The Travels of a Hunting Knife.....	DR. A. J. WOODCOCK 261
A Morning's Duck Shooting. Illustrated.....	H. W. CLOSS 265
When the Frost is on the Pumpkin. Poem.....	A. N. KILGORE 266
Gabe Bear's Baccy.....	THEODORE ROBERTS 267
Goose Shooting in Manitoba. Illustrated.....	H. M. LAING 271
Granddaddy's Ol' Rifle. Poem. Illustrated.....	J. B. ADAMS 274
The Grizzly's Ghost.....	STANLEY MAYALL 276
The Duck Shooter's Complaint. Poem.....	A. M. H. 277
A Night in a Fishing Hut.....	W. ROGERS 279
The Colonel's Victory.....	A. L. VERMILYA 314

	PAGE
Down Over the Old Buena Vista Trail Came a Lone Horseman.....	FRONTISPIECE
The Mystery of Stirrup Ranch. Illustrated.....	H. N. BEECHER 331
Tex. Poem. Illustrated.....	J. H. SMITH 335
Elk in Wyoming. Illustrated.....	S. N. LEEK 337
De Huntah's Jubilee. Poem.....	FRED W. GOSHORN 338
A Turkey Hunt in New Mexico. Illustrated.....	J. E. BECK 339
September. Poem.....	C. C. HASKINS 340
A Turkey Hunt of Long Ago. Illustrated.....	M. B. 341
Our Hunt at Fence Lake, Mich.....	JOE A. BOTTKOL 343
Picture Making with the Aid of the Camera. Illustrated.....	K. ROWA 345
Hunstan Come. Poem.....	C. G. RIDEOUT 346
In the Upper Peninsula. Illustrated.....	A. B. RICHMOND 347
Bill Brown's Retriever.....	PALMER C. GOBLE, JR. 351
Four Surprises at Once.....	JACK WOOD 352
Lost in the Devil's Garden. Illustrated.....	J. E. TYLOR 353
My Balsam Pillow. Poem.....	MEDA 357
To My Pipe. Poem.....	ARNOLD TOWNSEND 358
Duck Shooting on Ipswich Bay.....	M. R. LOVETT 359
Heliographing on Mount Adams.....	C. E. RUSK 361
A West Texas Hunt.....	HON. H. S. MORAN 365
Deer in Colorado.....	M. S. BACON 367
When My Ship Comes In. Poem.....	A. L. VERMILYA 368
I Strung Them on the Barrel of My Gun and Started for the Boat.....	FRONTISPIECE
A Goose Hunt on the Rio Grande. Illustrated.....	S. B. GILLETT 413
The North Woods. Poem.....	W. M. BRYAN, M.D. 414
Duck Shooting on the St. Lawrence.....	ASHLEY D. CONGER 415
Leaves from a Trapper's Note Book. Illustrated.....	A. T. BICKFORD 417
The Architecture of a Beaver Dam.....	FRANK R. GROVER 419
Shoot'n Time. Poem.....	THOMAS JACKSON 420
Eccentricities of the Beaver.....	A. WHITEHEAD 421
Fox Hunting in New England.....	ERNEST RUSSELL 422
Harlequin Duck. Illustrated.....	ALLAN BROOKS 428
From Turkeys to Quails.....	T. H. FRAZER 429
Stice's Christmas Turkey.....	W. F. SHORT, JR. 430
Kitchi Gi-os-se Waw-be An-ne We-og.....	SIMON POKAGON 431
A White Rabbit Hunt.....	A. C. TODD 432
Winter. Poem.....	IRA SWEET 435
Antoine on Ice.....	W. E. PARKER 436
How I Killed My Boar.....	D. J. M'GILLIVRAY 437
In the Big Woods.....	H. S. BULL 439
Recollections of Burma.....	H. T. DAVIES 441
At Long Range.....	ALBERT W. DAVIES 443
A Vacation. An Idyl.....	C. C. HASKINS xxiv
From the Game Fields, 35, 115, 197, 283, 369, 445	Forestry.....60, 147, 226, 308, 393, 469
Fish and Fishing.....43, 127, 266, 293, 373, 451	Pure and Impure Foods, 63, 149, 229, 311, 395, 473
Guns and Ammunition.....47, 131, 211, 295, 337, 455	Publisher's Notes.....67, 151, 233, 476
Natural History.....53, 139, 217, 301, 386, 461	Editor's Corner.....70, 152, 234, 313, 397, 478
League of American Sportsmen..57, 143, 223, 305, 389, 464	Amateur Photography..74, 156, 238, 320, 404, 484
	Book Notices.....65, 231



# RECREATION

A Fishing Story of the Luck of a Lad.  
By FREDERIC BIGELOW.

WITH A PEELED POLE;

OFFICIAL ORGAN OF THE LEAGUE OF AMERICAN SPORTSMEN



FROM OIL PAINTING BY W. L. STEWARD.  
A THRILLING LEAP.  
(Land-Locked Salmon.)

PUBLISHED BY G. O. SHIELDS (COQUINA)  
23 WEST 24TH ST., NEW YORK

**BEN, THE LIFE STORY OF A CUB;**  
The Greatest Bear Story ever Written, with Numerous Illustrations by R. F. OUTCAULT.

There comes a time in the life of every individual when the use of a stimulant is not only advisable but necessary

As you approach the calm and mellow evening of your life you have doubtless learned the value of a pure and wholesome cereal stimulant to sweeten solitude and keep off the blues.

When choosing a stimulant for medicinal use or purpose of good cheer endeavor to obtain a mild soothing amiable fluid that does not inflame or excite, but gently stirs and quickens the life current.

REGISTERED AND SPECIAL BRANDS

Per Gal.	Per Gal.
<b>Holiday Pure Rye - 4.00</b> (Eleven Years Old)	<b>Old Gold Bourbon - \$4.00</b> (Eleven Years Old)
<b>Hermitage Rock &amp; Rye 4.00</b> <i>Superior</i> Five pounds of rock candy crystals to each gallon of seven year old Hermitage Rye whiskey, is used in the preparation of our Celebrated Rock and Rye.	<b>Jewel Port - 4.00</b> From Silva & Cosens, Oporto. A choice product of the grape.
<b>Bon Ton Cocktails - 4.00</b> Martini, Manhattan, Vermouth, Whiskey, Tom Gin and Holland Gin. Carefully prepared from the choicest materials, perfectly blended.	<b>Rainbow Brandy V.O. 4.00</b> The product of one of the best American Vineyards, with all the medicinal qualities of French Brandy.
<b>Ruthven Sherry - 4.00</b> From Duff, Gordon & Co. Warranted twenty years in the wood before bottling. Rich and fruity.	<b>Jupiter Gin - 4.00</b> From the Swan Distillery, Schiedam, Holland, where Good Gin comes from. Tastes differ. Many people appreciate Good Gin. Jupiter is the best the world affords.
	<b>Medford Old Rum - 4.00</b> From Daniel Lawrence & Sons, Medford, Mass.

On receipt of your order with \$6.00, we will ship 6 full quarts assorted to suit, transportation charges prepaid, to any railroad point in the United States where the charges for transportation do not exceed \$2.00. You cannot afford to let this chance go by. You never before had as good an offer.

If you accept our offer you will surely receive the **BEST** and the **MOST** for your money that ever came to you from any similar proposition.

Remit cash in registered letter or by express company or P. O. money order.

*References:* Any bank in Boston. Any mercantile agency or any distiller of importance in the United States.

**W. H. JONES & CO.,** Hanover & Blackstone Sts.,  
BOSTON, MASS.

ESTABLISHED 1851

# RECREATION

Copyright, December, 1902, by G. O. Shields

A Monthly Magazine Devoted to Everything the Name Implies

\$1.00 A YEAR.  
10 CENTS A COPY.

G. O. SHIELDS (COQUINA),  
Editor and Manager.

23 WEST 24TH STREET,  
NEW YORK

## CONTENTS OF THIS NUMBER

	PAGE
Ben Doubled Him Up into a Wad and Sent Him Spinning.....	FRONTISPIECE
Ben; the Story of a Cub. Illustrated.....	W. H. WRIGHT 3
The Bread of Idleness. Illustrated.....	ROBERT P. LOWRY 15
Photographing in the Moro Country. Illustrated.....	GEO. D. RICE 17
A Place Just East of Persia. Poem.....	A. L. VERMILYA 18
The Hawk Bounty Question. Illustrated.....	J. E. TYLOR 19
With a Peeled Pole.....	FREDERIC BIGELOW 21
The Seagull. Poem.....	EDITH M. CHURCH 22
A Study of Feathers. Illustrated.....	MARY M. CALDWELL 24
W'y De Fish Don' Bite. Poem.....	EDWARD BONNEL 25
What Wouldn't I Give. Poem.....	A. N. KILGORE 27
The Jacana. Illustrated.....	L. P. GRAY 28
Pounding the Wrong Coon.....	W. H. NELSON 29
Montana Reminiscences.....	J. A. DUFFY 31
The Florida Kid. XI.....	CHARLEY APOPKA 33
A Day Off. Poem.....	EMMA G. CURTIS 34
The Truant. Poem.....	E. L. SABIN 42
From the Game Fields.....	35
Fish and Fishing.....	43
Guns and Ammunition.....	47
Natural History.....	53
The League of American Sportsmen.....	57
Forestry.....	60
Pure and Impure Foods.....	63
Book Notices.....	65
Publisher's Notes.....	67
Editor's Corner.....	70
Amateur Photography.....	74

Entered as Second-Class Matter at New York Post-Office, Oct, 17, 1894.



## TIDINESS and COMFORT for all men by using WASHBURNE'S Cuff Holders

*Instantly Attached or Detached.*

Sent Prepaid for . . . . . 20 Cents.  
Scarf Holder . . . . . 10 Cents.  
Key Ring and Chain . . . . . 25 Cents.

*They never come loose—a tiny lever with a bulldog grip.*

Illustrated Catalogue of others on request.

AMERICAN RING CO., Dept. 44, Waterbury, Conn

## Skin Diseases

Eczema, Salt Rheum, Pimples, Ringworm, Itch, Ivy Poison, Acne or other skin troubles, can be promptly cured by

# Hydrozone

Hydrozone is endorsed by leading physicians. It is absolutely harmless, yet most powerful healing agent, that cures by destroying the parasites which cause these diseases.

**Cures sunburn** in 24 hours. In cases of Prickly Heat and Hives it will stop itching at once, also will relieve mosquito bites instantly. Take no substitute and see that every bottle bears my signature.

**Trial Size, 25 Cents.**

**At Druggists or by mail, from**

*Prof. Charles H. Harchand*

**F-59 Prince St., New York.**

**FREE** {Booklet on the rational treatment of diseases sent free.

# Waltham Watches

Accurate and durable.

*“The Perfected American Watch,” an illustrated book of interesting information about watches, will be sent free upon request.*

*American Waltham Watch Company,  
Waltham, Mass.*



**\$30.00**

## Colorado

AND RETURN

First-class to Denver, Colorado Springs and Pueblo from Chicago, commencing June 1 and continuing throughout the summer, good returning October 31. Tickets reading to same points and return will be sold at the rate of \$25.00 from July 1 to 10. Return limit, August 31. Correspondingly low rates from other points.

## The Colorado Special

fast daily train, one night to Denver from Chicago and the Central States (only two nights en route from the Atlantic seaboard), leaves Chicago daily 6.30 p. m.

A second daily train leaves Chicago 11.30 p. m.  
Personally conducted excursions in tourist sleeping cars.

All agents sell tickets via this route.  
Write for particulars to W. B. KNISKERN, P. T. M.  
C. & N.-W. Ry., Chicago.

**Chicago, Union Pacific and  
North-Western Line**

CS12





THE OLD WAY

**T**HE BOAT as pictured below in every detail—length  $15\frac{1}{2}$  feet, beam 4 feet, with  $\frac{3}{4}$  horse-power Blomstrom gasoline engine

**\$100**

*So simple a child can operate  
with entire safety*

Catalogue D, including Marine Gasoline Engines of from  $\frac{3}{4}$  to 80 horse-power at corresponding prices, free on request.

**THE C. H. BLOMSTROM MOTOR CO.**  
1284-1294 River Street, Detroit, Mich.

*(From the Chicago Journal, May 7th).*

At last an honest soul has put a  $15\frac{1}{2}$  foot launch with gasoline engine—4 foot beam—within the reach of the masses.

THE NEW WAY



# Abercrombie & Fitch

World's  
Headquarters  
for  
Fishing Tackle



## A 3 Cent Bait

in postage stamps will bring the biggest catch an angler, camper or sportsman can land—Abercrombie and Fitch's catalogue R, 160 pages, cuts and prices.

We guarantee to furnish a more satisfactory fisherman's outfit than can be obtained elsewhere.

**Complete outfits for explorers, campers and prospectors. Camp outfits from the most modest and practical to the most complete and luxurious.**

Compare our prices on tents, clothing, cooking outfits, folding buckets, camp packs, cots, chairs, food bags, folding shelves, guns, boots, moccasins, sleeping bags, pack saddles, stoves, pneumatic beds, cushions, duffle bags, pack harness, folding bakers, folding lanterns, rolling tables, fishing tackle, shoes, covers, &c.

314-316 BROADWAY, NEW YORK CITY

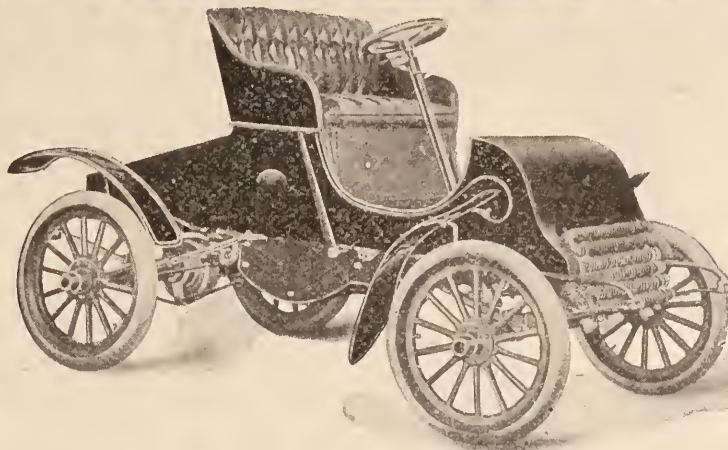

The Cadillac Runabout

# The Cadillac

## The Automobile that Solves the Problem

Until the CADILLAC was made, all automobile construction was more or less experimental—no one had made an entirely satisfactory motor vehicle. This machine is made on a new system developed from the experiences of all previous makers: the faults and weaknesses of the old methods have been avoided and a new ideal of motor travel developed that gives a perfect vehicle for comfort, speed, absolute safety, greatest durability, simplicity of operation, wide radius of travel, and reliability under all conditions of roads. There is no other automobile that can be compared to the Cadillac in any particular of speed, stability, ease of operation or convenience of use. You should not buy before examining this wonderful new machine. Price f.o.b. at factory, \$750.

The new tonneau attachment, at an extra cost of \$100, gives a combination of light carriage for city streets and substantial touring car for country roads—practically two motor vehicles in one, with a seating capacity of two or four, as required—a very graceful effect in either use. Write for new illustrated booklet. K.

**CADILLAC AUTOMOBILE COMPANY, Detroit, Mich.**

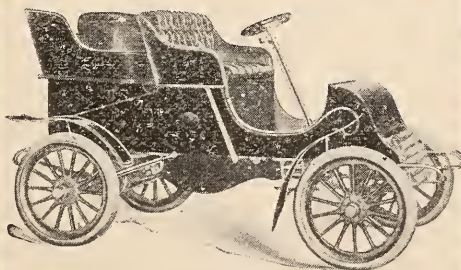

With detachable tonneau

# \$25 <sup>To</sup> Colorado *and* Back

From Chicago, every day, July 1 to 10, inclusive. Return limit, August 31, 1903. These are some of the inducements to spend a vacation among the Rockies offered by the

## **Chicago, Milwaukee & St. Paul and Union Pacific Line.**

You can leave Chicago at 10.25 any evening and enjoy a quick, comfortable trip to Colorado. Standard sleeping cars and free reclining chair cars from Union Station, Chicago, to Union Station, Denver. Additional information on request.

F. A. MILLER,  
General Passenger Agent,  
CHICAGO.

**Christian Endeavor Convention, Denver, July 9 to 13.**



# THE FOUR-TRACK NEWS

An Illustrated Magazine  
of Travel and Education

MORE THAN 100 PAGES MONTHLY

Its scope and character are indicated by the following titles of articles that have appeared in recent issues:

Picturesque Venezuela—Illus. . . .	Frederick A. Ober
Haunts of Eben Holden—Illus. . . .	Del B. Salmon
A Journey Among the Stars—Illus. . . .	Frank W. Mack
In the Great North Woods—Poem . . . .	Eben B. Rexford
Beautiful Porto Rico—Illustrated	Hezekiah Butterworth
In Rip Van Winkle's Land—Poem . . . .	Minna Irving
Nature's Chronometer—Illustrated . . . .	H. M. Albaugh
Van Arsdale, The Platitudinarian—Ill.	Chas. Battell Loomis
The Three Oregons—Illustrated . . . .	Alfred Holman
Ancient Prophecies Fulfilled—Illus. . . .	George H. Daniels
The Stories the Totems Tell—Illus. . . .	Luther L. Holden
A Little Country Cousin—Illustrated	Kathleen L. Greig
The Mazamas—Illustrated . . . .	Will G. Steel
When Mother Goes Away—Poem . . . .	Joe Cone
A Little Bit of Holland—Illustrated	Charles B. Wells
The Romance of Reality—Illustrated	Jane W. Guthrie
Samoa and Tutuila—Illustrated . . . .	Michael White
Under Mexican Skies—Illustrated . . . .	Marin B. Fenwick
Niagara in Winter—Illustrated . . . .	Orrin E. Dunlap
Little Histories—Illustrated . . . .	
Old Fort Putnam . . . . .	William J. Lampton
The Confederate White House . . . . .	Herbert Brooks
The Alamo . . . . .	John K. Le Baron

SINGLE COPIES 5 CENTS, or 50 CENTS a YEAR

Can be had of newsdealers, or by addressing

GEORGE H. DANIELS, Publisher

Room No. 48

7 East 42d Street, New York

"Free from the care which wearies and annoys,  
Where every hour brings its several joys."

## "AMERICA'S SUMMER RESORTS"

This is one of the most complete publications of its kind, and will assist those who are wondering where they will go to spend their vacation this summer.

It contains a valuable map, in addition to much interesting information regarding resorts on or reached by the

NEW YORK CENTRAL LINES

A copy will be sent free, postpaid, to any address on receipt of a two-cent stamp, by George H. Daniels, General Passenger Agent, New York Central & Hudson River Railroad, Grand Central Station, New York.

"There's recreation in the books themselves."

## 77 Information

## Bureaus of the

## New York Central Lines

Each city ticket office of the New York Central, Boston & Albany, Michigan Central, Lake Shore, Big Four, Pittsburg & Lake Erie, and Lake Erie & Western Railroads in the cities of New York, Brooklyn, Boston, Worcester, Springfield, Albany, Utica, Montreal, Syracuse, Rochester, Buffalo, Niagara Falls, Toronto, Detroit, Cleveland, Pittsburg, Columbus, Indianapolis, Cincinnati, Louisville, St. Louis, Chicago, Denver, San Francisco, Portland, Los Angeles, and Dallas, Texas, is an information bureau where desired information regarding rates, time of trains, character of resorts, hotel accommodations, and a thousand and one other things the intending traveler wants to know will be freely given to all callers.

A copy of the 52-page Illustrated Catalogue of the "Four-Track Series" will be sent free upon receipt of a two-cent stamp by George H. Daniels, General Passenger Agent, New York Central & Hudson River Railroad, Grand Central Station, New York.

"A sublime spectacle."

## NIAGARA

## FALLS

One of the natural wonders of the world. A charming place at any season of the year, reached from every direction by the

NEW YORK CENTRAL LINES

A visit to the Falls is an object lesson in geography; an exhibition of landscapes that no painter can equal, and a glimpse of the latest developments of the industrial world.

A copy of Four-Track Series No. 9, "Two Days at Niagara Falls," will be sent free, postpaid, to any address on receipt of a two-cent postage stamp, by George H. Daniels, General Passenger Agent, New York Central & Hudson River Railroad, Grand Central Station, New York.

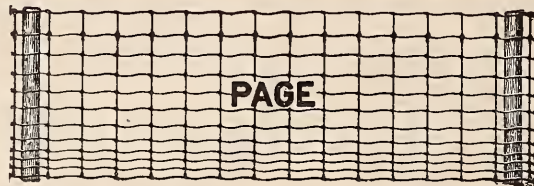

## PADDOCK

Among all the wire fences made, there is not one that is a perfect Paddock Fence.

But, if you must really have a Paddock, and think that wire will answer, then we believe that our 20 or 25 Bar, 58-Inch Fence comes the nearest of all to being a Paddock Fence.

It is closer woven, and has more real practical elasticity than any other make.

Many horsemen use our 88-inch Buffalo Fence for paddocks, because it keeps the animals' heads apart.

**PAGE WOVEN WIRE FENCE CO.**

BOX 39, ADRIAN, MICHIGAN.

## No Picture

can show you the good qualities of the KENWOOD SLEEPING BAG. You must see a complete combination bag to understand how perfectly it is adapted to the use of every man who sleeps out of doors or in a tent, under all conditions of climate and weather.

If your dealer does not have the KENWOOD SLEEPING BAG, write us for samples, prices and full information, then decide which quality you want and order it on approval. If it does not suit you in every way return it. We pay charges both ways. Don't buy any other sleeping bag or blankets before you have seen the Kenwood.

**THE KENWOOD MILLS**

ALBANY, N. Y.

# Special California Tours

Coronado Beach.



Our personally-conducted excursions to California have been very successful.

I am now organizing several similar parties for July and August. Will gladly send you full particulars of special advantages offered. Rates very low. Accommodations excellent. The best California line will be used—the Santa Fe. Why not go this summer and enjoy Pacific Ocean breezes and snow-capped Sierras? En route see Grand Canyon of Arizona. An unusual opportunity—don't miss it.

*Write to W. J. Black, 1312 Great Northern Building, Chicago, for full particulars and free copy of beautiful book about California.*

## Santa Fe All the Way

# VACATION DAYS

Where are you going for your vacation this summer, and how?

There are many delightful places: Lake Chautauqua, St. Lawrence River, Adirondack and White Mountains, Atlantic Coast, Canada, Niagara Falls, South Shore of Lake Erie country, and its lovely Islands; lakes of the Northwest, Yellowstone country and Colorado places.

The service of the Lake Shore & Michigan Southern Railway—unequaled for completeness and comfort—may be used with greatest advantage for reaching all these summer places.

**Privileges**—Enjoyable privileges accorded on tickets over Lake Shore—stop-over at Lake Chautauqua, Niagara Falls, Lake Erie Islands, option of boat or rail between Cleveland and Buffalo, etc.

**Summer Books**—Sent for 6 cents postage by undersigned: "Lake Shore Tours," "Lake Chautauqua," "Quiet Summer Retreats," "Privileges for Lake Shore Patrons," "Book of Trains."

**Boston Excursions**—Over the Lake Shore, July 2, 3, 4 and 5. Good until September 1. Very low rates. All railways sell in connection with Lake Shore.

**Chautauqua Excursions**—Over Lake Shore, July 3 and 24, from all points west of Cleveland. Good 30 days. Low rates.

A. J. SMITH, G. P. & T. A., Cleveland, O.



**“NOTHING SO RARE AS RESTING ON AIR.”**



TAKING MINE EASE.

The only article in your outing outfit that you can use during the whole year is a

# Pneumatic Mattress OR CUSHION

**THE EVER PRESENT ROOT**

in the bed of boughs is a thing of the past if you use a Pneumatic Mattress. A mattress for home use that you can deflate, pack in your grip and take with you into camp.

**SPRUCE BOUGHS**

may make a fine bed. But the genuine Sportsman prefers a Pneumatic Mattress because he knows he can do three times the tramping the day following a night's good sleep.

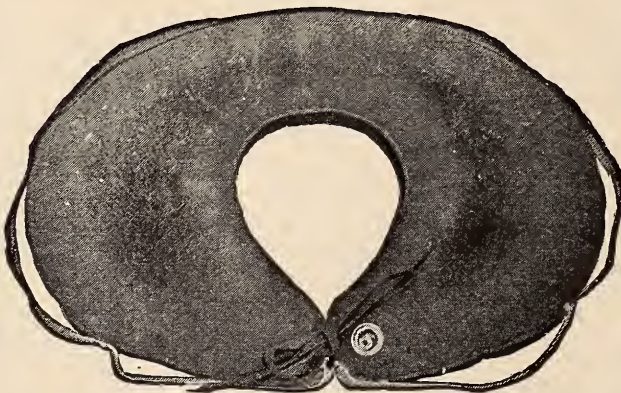

PRICE \$2.00

Carry it in your Pocket, it weighs just One Pound.

*Sportsman's Cushion*

- A Yoke to save your shoulders
- A Swimming Collar for those who can't swim.
- A Life Preserver in case of accident.
- A Cushion while waiting for Moose.
- A Cushion or Head Rest while waiting for Duck.
- A Protection for your shoulder if the gun is heavy.
- A Cushion for CAMP, BOAT, OFFICE or HOME.

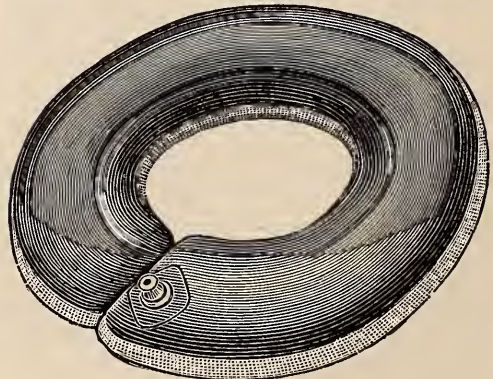

Swimming Collar.

*Swimming Collar.*

Worn around the neck, leaving the arms free for action. Will support a full-grown man. Just the thing when learning to swim.

Price, Small Size, \$1.50 Large Size, \$2.00

**Pneumatic Mattress & Cushion Company,  
2 R South Street, New York City.**



# PACK TRAIN

# TRAVELING

*in the Mountains  
is a glorious  
experience.*

*Read about it in*

**"WONDERLAND 1903"**

*Sent for six cents by  
Chas. S. Fee, GEN'L PASS'GR AGENT,  
ST. PAUL, MINN.*

Two Through Transcontinental Trains Daily.



# 1000 Island House

---

---

In the midst of the “Thousand Islands,” the so-called “Venice of America,” and really the most charming and delightful Summer Resort on the Continent.

Send me two 2-cent stamps and I will send you a beautifully illustrated guide book.                      Mention RECREATION.

O. G. STAPLES, *Owner and Proprietor*

## Alexandria Bay, N. Y.



TYPICAL SCENE - MUSKOKA LAKES

THE "ROYAL MUSKOKA" HOTEL, MUSKOKA LAKES, CANADA.

Is elegantly furnished, fine cuisine, magnificent surroundings, 1000 feet above sea level.

Most charming summer resort region in America. Perfect immunity from Hay Fever assured.

For full particulars, Illustrated descriptive literature, rates, maps, and all information, apply to

G. T. BELL, Genl. Passr and Tkt. Agent, GRAND TRUNK RAILWAY SYSTEM, MONTREAL, QUE.

OR TO MUSKOKA NAVIGATION CO., LTD., TORONTO, CANADA.

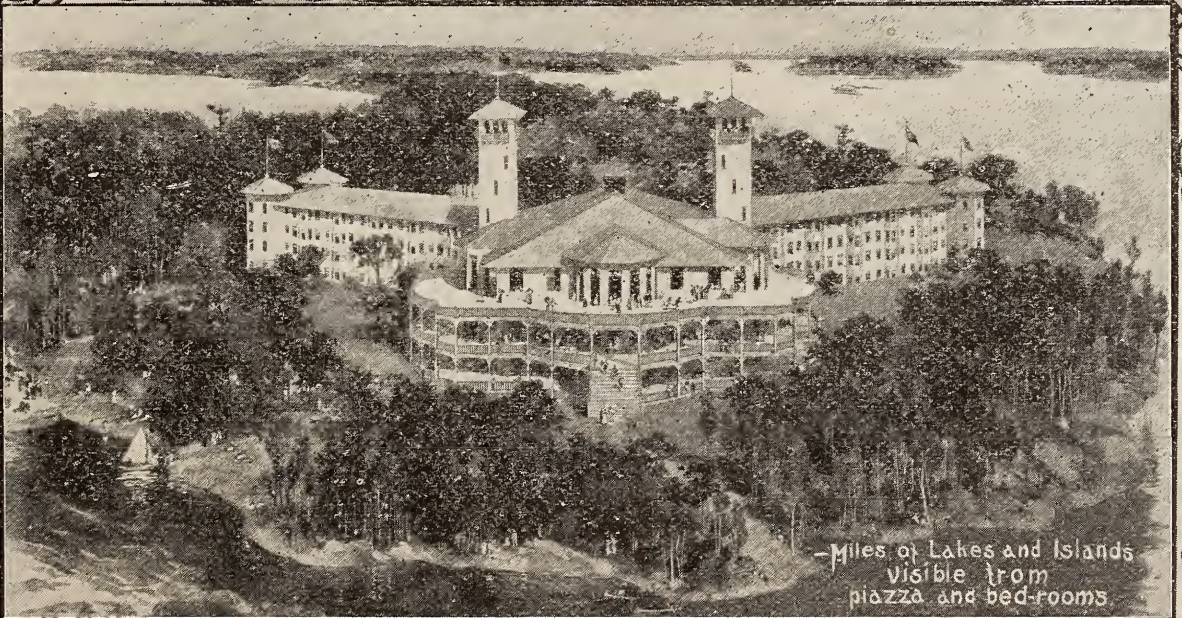

Miles of Lakes and Islands visible from piazza and bed-rooms

ROYAL MUSKOKA HOTEL

**"FOR 34 YEARS A STANDARD PIANO."**

# THE WING PIANO

**YOU NEED THIS BOOK** IF YOU INTEND TO BUY A PIANO. A book —not a catalogue— that gives you all the information possessed by experts. It makes the selection of a piano easy. If read carefully, it will make you a judge of tone, action, workmanship and finish; will tell you how to know good from bad. It describes the materials used; gives pictures of all the different parts, and tells how they should be made and put together. It is the only book of its kind ever published. It contains 116 large pages, and is named "**The Book of Complete Information About Pianos.**" We send it free to anyone wishing to buy a piano. Write for it.

**SAVE FROM \$100 TO \$200** We make the WING PIANO and sell it ourselves. It goes direct from our factory to your home. We do not employ any agents or salesmen. When you buy the WING PIANO you pay the actual cost of construction and our small wholesale profit. This profit is small because we sell thousands of pianos yearly. Most retail stores sell no more than twelve to twenty pianos yearly, and must charge from \$100 to \$200 profit on each. They can't help it.

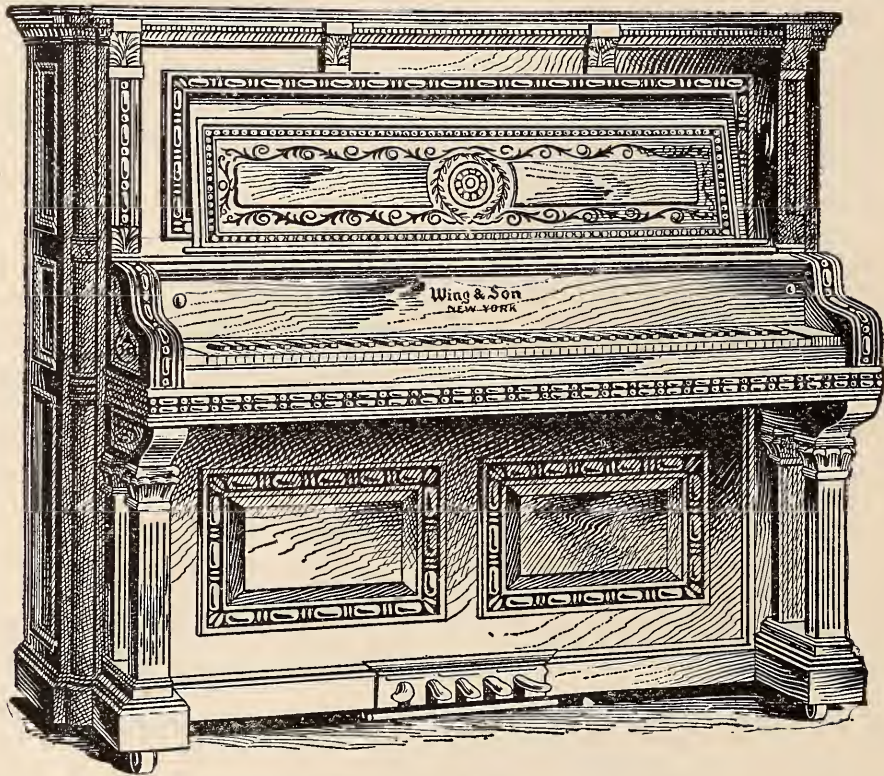

*A Wing style—45 other styles to select from.*

**SENT ON TRIAL** WE PAY FREIGHT. NO MONEY IN ADVANCE. We will send any WING PIANO to any part of the United States on trial. We pay freight in advance and do not ask for any advance payment or deposit. If the piano is not satisfactory after twenty days' trial in your home, we take it back entirely at our expense. You pay us nothing unless you keep the piano. There is absolutely no risk or expense to you.

Old instruments taken in exchange.

**EASY MONTHLY PAYMENTS.**

**INSTRUMENTAL ATTACHMENT** A special feature of the Wing Piano; it imitates perfectly the tones of the mandolin, guitar, harp, zither and banjo.

**IN 34 YEARS 33,000 PIANOS** We refer to over 33,000 satisfied purchasers in every part of the United States. WING PIANOS are guaranteed for twelve years against any defect in tone, action, workmanship or material.

**WING ORGANS** Are just as carefully made as Wing Pianos. They have a sweet, powerful, lasting tone, easy action, very handsome appearance, need no tuning. Wing Organs are sold direct from the factory, sent on trial; are sold on easy monthly payments. For catalogue and prices write to

**WING & SON,** 226 and 228 East 12th St.,  
NEW YORK.

1868—35th Year—1903.





FOR DOG WORMS ALWAYS USE  
SERGEANT'S  
"SURE SHOT."

That's the name **POLK MILLER** gives his remedy for freeing dogs from worms,—generally worms from puppies.

Many finely bred dogs die before maturity when afflicted with worms. If they do not die, worms hold them back, destroy natural instincts, and often prevent the development of those qualities that ought to make puppies greater dogs than their parents.

Like children afflicted with worms, the pup becomes **inanimate, sickly and thin.**

Abnormal appetite that is bound to destroy the digestion and cause functional disorders which develop into chronic ailments **are the result of worms.**

If sometimes they do not die, worms leave them no good and a disgrace to their breeding.

**Canine worms** should be treated for immediately symptoms show.

All the time "SURE SHOT" is destroying worms it is putting into splendid condition the valuable pup patient. The pup will come out of his sickness with limpid eyes, keen sense, sleek coat, normal bone and muscle development. The following testimonial shows its efficacy. You may know the writer.

GREENBRIER, ALA.

"Sergeant's Sure Shot" is the only thing I have ever used with success. It has saved more than one dog for me, and I never expect to lose a dog from worms so long as I can get it." **WILLIAM M. HUNDLEY.**

**SERGEANT'S SURE SHOT** per bottle 50c. Sold by Druggists or Sporting Goods Dealers everywhere or mailed (prepaid) from

**POLK MILLER DRUG CO.,**  
**RICHMOND, VIRGINIA, BOX 217.**

There isn't anywhere a dog lover or owner, who wouldn't like to have our 48 page Treatise on Dogs. We will send it and a Pedigree Blank to any address for 3 cents in stamps which go to pay the postage.

# TAKE YOUR CHOICE.

## 1 QUART \$1.00

## 4 QUARTS \$3.20

### WE PAY EXPRESS CHARGES IN EITHER CASE.

We have one of the largest distilleries in the world. We are the largest bottlers of whiskey in the world. We have more whiskey in our eight Bonded Warehouses than any other distiller in the world. There is more **HAYNER WHISKEY** sold than any other brand in the world. We have been in business for over 37 years, serve regularly half-a-million satisfied customers and have a capital of \$500,000.00 paid in full, so you run no risk when you deal with us. Don't forget that **HAYNER WHISKEY** goes direct from our own distillery to you, with all its original strength, richness and flavor, thus assuring you of absolute purity and saving you the enormous profits of the dealers. Don't forget that a **HAYNER** quart is an honest quart of 32 ounces, 4 to the gallon. It takes 5 of the ordinary "quarts" to make a gallon. We give one-fourth more in every bottle, reducing our price just that much. You get both quality and quantity

# HAYNER WHISKEY

Send us \$1.00 for **ONE QUART** or \$3.20 for **FOUR QUARTS** of **HAYNER SEVEN-YEAR-OLD RYE**, and we will pay the express charges. We ship in a plain, sealed package; no marks to even suggest contents. When the whiskey reaches your home, try it, sample it thoroughly. Then, if you don't find it all right, perfectly satisfactory in every way and better than you ever had before or can buy from anybody else at any price, ship it back to us at our expense and your money will be promptly refunded. We stand all the expense if you don't wish to keep the whiskey. **YOU** risk nothing. We ship one quart on your first or trial order only. All subsequent orders must be for at least 4 quarts at 80 cents a quart. The packing and express charges are almost as much on one quart as on four and even at \$1.00 for one quart we lose money, but we want you to try it. **WE PREFER TO HAVE YOU ORDER FOUR QUARTS FOR \$3.20 RIGHT NOW FOR THEN WE WILL MAKE A LITTLE PROFIT AND YOU WILL ALSO SAVE MONEY.** But take your choice. \$1.00 for 1 quart or \$3.20 for 4 quarts, express prepaid. Your money back if you're not satisfied.

Trial orders for Ariz., Cal., Col., Idaho, Mont., Nev., N. Mex., Ore., Utah., Wash., or Wyo. must be 1 Quart for \$1.25 by **EXPRESS REPAID**. Subsequent orders on the basis of 4 QUARTS for \$4.00 by **EXPRESS PREPAID** or 20 Quarts for \$16.00 by **FREIGHT PREPAID**.

Remit by Check, Bank Draft, Express or Money Order. It is unsafe to send currency unless you register your letter. Write our nearest office and do it **NOW**.

ESTABLISHED  
1866.

**THE HAYNER DISTILLING COMPANY,**

DISTILLERY  
TROY, OHIO.

DAYTON, OHIO.

ST. LOUIS, MO.,

ST. PAUL, MINN.,

ATLANTA, GA.,







BEN DOUBLED HIM UP INTO A WAD AND SENT HIM SPINNING

# RECREATION

Volume XIX.

JULY, 1903.

Number 1.

G. O. SHIELDS, (COQUINA) Editor and Manager

## BEN; THE STORY OF A CUB.

W. H. WRIGHT.



IN the spring of 1890 we went into the Bitter Root mountains to hunt bear. About the second day out we found a female black bear and 3 cubs, that were only a few days old. We killed the mother and captured the

children. We at once divided the latter among ourselves, Spencer taking one, O'Brien one and I the other.

O'Brien, whom I shall hereafter call Jack, because he does not deserve a better name, chose the female, the other 2 cubs being males. Spencer and I, of course, adopted a humane system of treatment for our pets, but O'Brien undertook to train his by cussing and beating it. The little girl rebelled at this from the start, and learned to hate her master violently. Fortunately for her, and for the peace of the camp, she lived only a few weeks and never missed an opportunity to bite and claw her keeper viciously. It served him right; for he was a cruel brute and we should have been glad if she had got him by the throat some night while he was asleep, and sent him over the divide.

Her hatred of the biped freak was really picturesque, and at the same time pathetic. She would eat or drink but little and was weak and sickly all the time; but to the day of her death she managed, at frequent



O'BRIEN.

intervals, to get in her work on the Irishman. Not 10 minutes before she breathed her last she tried to bite him, and we were only sorry she did not succeed in getting a good hold.

Spencer, though kind and careful of his charge, did not succeed in raising the little cub. It lived about a month, and finally sickened and died. We fed them all on canned milk for a time, and my pet thrived on it. He became at once the life and joy of the camp. He learned to romp and play with us like a kitten or a puppy, and



LISTENING.



we taught him many amusing tricks. He was one of the most interesting pets and apt pupils I ever undertook to train, and I have owned and trained many.

Occasionally Ben and his brother would fall out and have a scrap. They would stand up and spar like trained pugilists, until one would seem to

horses in the outfit, and in the morning, when we were ready to pack, one of us would bring them in from the feeding ground. Ben's was a little white pony, named Pard. As soon as Ben saw him coming, he would begin to squall and start for his mount. He would take his place beside the horse, and was all impatience while we were



A FAMILY SCRAP.

get a temporary advantage of the other. Then they would clinch, claw, bite and scratch like cats, and we would have to separate them, even though the trouble came at dead of night.

We built Ben a cage of willow boughs, woven together, in which he was to ride during the day. We were on the march most of the time, and within a week from the day we caught Ben, and named him, he learned to know his horse. We had 8

packing. He knew when the load was being put on his horse as well as we did, and would dance around him, pawing his legs, jumping at his nose and otherwise expressing his delight, just as a dog would. When the lash rope, was finally made fast, and the cage tied on top of the pack, we would boost Ben up and put him in.

He would express his delight by whimpering and cooing to us and to the horse, and dancing about in the cage. He soon got tired of this



confinement, however, and went to biting his cage and tearing it to pieces with his claws. It withstood this only a day or 2, and after that we simply put a collar and a dog chain on the little chap. We would fasten the other end of the chain to the pack, and the bear would sit on the load and ride as gracefully as a circus monkey. He soon learned to vary the monotony of his daily ride by taking hold of the chain with one paw a little above his neck, dropping off the load and swinging about the horse's legs. At first Pard, the pony, objected to this, and would buck and kick and dance; but he gradually made up his mind that this was use-

less, and thereafter was patient under all kinds of scratching and biting which the little imp saw fit to inflict on him. Finally Ben would hang on to his chain with one foot and would apparently go to sleep, dangling against the horse's legs as he walked or cantered along the rail.

In the course of the next 2 or 3 weeks we killed several other bears, and finally had 14 bear skins in the outfit. When we would get into camp we would spread these out, to continue the drying process. Every time they were thrown out, and as soon as Ben was released from the load, he would go hunting among them, and within a few minutes would find the



GOOD MORNING, PARD.



SPRINTING FOR COVER.

skin of his mother. It was truly pathetic to note the little fellow's grief at this. He would smell of the skin, lie down on it, put his nose between his feet and cry like a baby. Then he would get up and walk around it, nose it and caress it with his paws, and apparently try to wake his mother into life. The ordeal was so trying to him and to us that we finally quit opening this skin when we got into camp. We rolled it up tightly in heavy canvas and as soon as we reached camp we put it up in some tree where Ben could not find it. Still, he would search through the skins for his mother, and eventually we had to keep them all out of his sight. I have never seen, in all my study of wild animals, anything half so touching or so heartrending as Ben's grief for his dead mother.

When Ben was about a month old,

we killed a moose. We threw the green skin over one of the packs, for a few days, with the flesh side up. It dried in the shape of the pack, which, as you know, is an oval. One night we threw this off carelessly, and it lit with the edges on the ground forming a complete house, or tent, so to speak. When Ben was taken off his horse he found this, raised one end, crawled under, and from that day to the time when we completed our trip, late in the fall, the moose skin was his tent. He knew it, and apparently became as much at home under it as any of us in our tents. If any unusual disturbance were made about camp, if a dog barked, or if a shot were fired, if a horse neighed, or if any one of us, or a stranger, came suddenly into camp, Ben would make a dive for his tent, grab one end of it with a forefoot,



hoist it, and shoot under as if he had been fired from a gun; and there he would stay until the trouble was over. Occasionally he would stick his head out from under his shelter, look carefully about the camp and listen. When assured there was no further danger, he would come out and resume his play, or feeding, or whatever he might have to do.

or high bush huckleberries, or anything such ground might furnish. He would occasionally dig up a bulbous plant of some kind and eat the root; and we never knew him to dig up a plant that did not have an edible root. He knew from the first, much better than we did, what plants grew his favorite breakfast.

It is evidently the habit of mother



RUSTLING FOR BREAKFAST.

As I have said, he was only a few days old when we got him, but from the start he seemed to know what kind of food bears live on, how to find it, and how to go about getting it. When he was a month old, and began to eat solid food, if we camped on a hillside where huckleberries or rose bushes grew, he would go foraging among them. When he found a bush of the kind that bore fruit to his liking, he would bend it down and examine it, and he never, from the first, pulled down any bush that does not, in season, bear fruit of some kind. If we camped near a swamp he would go into this and hunt for cranberries,

bears to feed their young at frequent intervals, at least during the night. Ben seemed to know this. Furthermore, he was blessed with a ravenous appetite and a rapid digestion. We would feed him as soon as we got in camp, and before we had our supper. Then we would feed him again before we went to bed. By the time we had slept an hour or 2, Ben's second supper would seem to be digested and he would get hungry and set up a howl. Someone would have to crawl out and feed him. Then he would curl up in his gunny sack and go to sleep. We hit on a plan of wrapping him up in the gunny sack, hoping



WAITING FOR IT TO COOL.

this would keep him quiet until morning. Not a bit of it. He would get hungry all the same and dig out of his swaddling cloth. He would come whining and crying around in the tent, and there was no rest for any of us until he had had a lunch. The boys gave vent to a great deal of profanity about these frequent interruptions of their slumbers, but they were so fond of little Ben that none of us would for a moment entertain a proposition either to kill him or to leave him in the woods; so we kept our nursery running day and night, even if we had to work overtime.

While Ben was in his infancy, and was being fed on spoon victuals, we would sometimes make a gravy of milk and flour, and add perhaps a little bacon grease, or something else we thought he might like, and within 3 days after we commenced to prepare such food, he learned to recognize the frying pan when he saw it taken out. When one of us would pick it up and start for the fire, he

would squall and follow us. He would scramble over us, stand up on his hind feet and watch the proceedings as impatiently as a child would watch the preparation of its breakfast. When the mess was cooked he was at first eager to jump into it, but he soon learned it must first cool before he could eat it. Then he would sit by the frying pan and lick his chops, whine, and dig up the ground around it in impatience. Occasionally he would feel of it with his paw to see if the mess was cool enough to eat. As soon as it reached a temperature that was safe for him, he would put his feet on the edge of the frying pan, chuck his nose in, drink and lap as long as he could hold his breath. Then he would stop, and after a moment of breathing, would sail in again.

As soon as Ben was old enough so we thought his stomach would stand it, we gave him pieces of fresh meat and bacon. At first we cooked it for him, then we gave him a taste of it in the raw state. He seemed to

know what his mother would have preferred if she had been with him, and formed his taste accordingly. After a few days of this process of feeding, he would not taste cooked meat, unless half starved. He wanted it raw, and from that time we did not dare leave any fresh meat within his reach, except such as we wanted him to have. We had to hang the venison, the birds and the fresh fish in trees.

Then we taught Ben to turn somer-

hill. He would make perhaps half a dozen turns, and then stop and look up, as much as to say:

"Is that enough?"

If I said:

"No, go ahead," he would double up and away he would go again. When I said,

"All right," he would come for the mess table. Finally, as soon as I would pick up the frying pan and start for the fire, he would begin



PLAYING CIRCUS FOR JERRY.

saults. He took to these circus antics readily, and thereafter whenever his meal was ready, I would say to him:

"Now, Ben, turn a somersault and you may have your breakfast."

Immediately he would double up like a ball and go rolling down the



turning somersaults; and perhaps every 3 minutes during the cooking process he would spin a few, and then look up to see if I were ready for him.

Sometimes when going through brushy country we would put Ben in a gunny sack and tie this on the pack. One evening when we struck camp and were throwing off the packs, Jerry Johnson, an old trapper, came around. After the usual greetings he was looking about camp and saw the gunny sack showing evidence of internal life. He asked me what was in it. I told him a cub. He said,

"May I see it?"

I said,  
 "Yes, just open the sack and dump him out."

Ben seemed to have his mind already on the price of his supper, for when the old fellow dumped him out on the slope of a hill, Ben turned perhaps 20 somersaults before he uncurled. The old prospector laughed until he almost broke his suspenders.

One day after Ben had grown to be about 2 months old, we were crossing a bad washout when Pard and another horse fell and lay with their feet upward. Of course there was the usual commotion and anxiety to save the horses and the packs. We all jumped for the 2 unfortunates, loosened the cinches, got the horses on their feet as soon as possible, and



LOOKING OVER THE CAMP GROUND.

then commenced to dig out the packs.

Up to that time no one had thought of Ben, but when Pard's last pack was rescued from the mud, Spencer said,

"Here's poor little Ben"; and taking him by the hind feet, pulled him out, covered with mud, and looking as thoroughly disreputable as any cub ever could look, but really none the worse for his adventure.

Ben kept on growing, of course,

and within a few weeks he could reach the cinch which held Pard's load on. When that time arrived, he would no longer wait to be helped up, but when he found the load was about completed, he would stand up, place his left foot on the horse's forelegs, grab the cinch with the right, and then climb to the top of the pack.

Ben could beat any watch dog I ever saw at seeing, scenting or hearing people.

If one of us was away from camp, and was returning, those in camp were always warned of the approach by Ben, long before the men could hear a sound. No matter how busy he might be, eating or playing or howling for food, all at once he would stop and stand like a graven image for a few seconds, listening, looking and pointing his ears in some certain direction. Then he would stand up on his hind feet and look and listen. By and by he would conclude that the danger was too great for him to risk his precious body any longer in sight, would go for his moosehide tent, grab one end and shoot under it. Perhaps 5 or 10 minutes later we would see or hear some member of our party, or possibly some stranger, coming up the trail.

Frequently when we had all been away from camp, Spencer and I would try to sneak to camp and surprise Ben. We were both old hunters and are vain enough to imagine we are good stalkers, but never, in the course of the entire summer, were we able to get in sight of the camp without Ben's knowing of our approach long before he could see us. We have crawled on our hands and knees, in the stealthiest manner possible to the top of the nearest ledge, or behind some big log or rock that concealed us entirely from the camp, perhaps 200 yards away. When we reached our final hiding place, and raised our heads carefully, we would see one of Ben's ears poked out at us from behind a tree, or from under the edge of

his tent. Our efforts to stalk him took the conceit out of us completely.

On one occasion we were camping on a trout stream. Ben was sunning himself on a gunny sack near the tent, apparently sound asleep. Suddenly he jumped, looked up the creek, stood up, listened some more, then circled about the camp, sniffing the air and occasionally stopping to listen. He kept this up 10 or 15 minutes. Then he sought the seclusion of his moosehide tent. We kept listening and looking up the creek, but during all that time we could see nothing, nor could we hear anything but the roar of the water. Half an hour after Ben gave the first alarm, a man came in sight, fishing down the creek. Then we knew what had been troubling the cub all that time.

Ben liked Spencer very well, but always hated the Irishman. He was especially fond of me, naturally, because I fed him and cared for him more than Spencer did. If I lay down in camp during the day, Ben would immediately come and cuddle up beside me, laying his head on my arm. He would sleep as soundly as I did for any length of time if all went well; but if he heard any unusual noise, or if the breeze brought a suspicious scent to camp, Ben would jump as if someone had prodded him with a sharp stick. His sudden awakening would, of course, arouse me, and in almost every instance someone would come into camp; or perhaps we would hear an elk or a deer passing through the brush somewhere within 100 or 200 yards of camp.

We returned home in September. Ben was by that time a lusty cub, and while the family immediately learned to love him, he was a great trial to us all. We turned him loose in the house, and he seemed to think he could run through it just as he did about the camp. He would play with the children as a puppy would, chasing them from room to room; and in his eagerness would upset chairs, ta-

bles, or any other furniture that came in his way. Two or 3 times when the table was spread for a meal he grabbed the cover, yanked it off and smashed the china to bits. He seemed not to care a blank for expense.

I gave Ben an old piece of garden hose, about 10 feet long, to play with. He seemed to take great delight in shaking it, just as a puppy would, and often amused himself in this way for an hour at a time. Occasionally I would get hold of one end of it, put it to my mouth and shout at him through it, calling him by name. He would stop and look about until he found that the noise came from the end of it nearest to him. He would



BEN'S PRIVATE TELEPHONE LINE.

then take this up, put it to his ear, and listen carefully. Placing my end of the hose to my mouth I would again shout, Ben. He would listen intently, look down along the outside of the hose, and then sitting up on his haunches, would hold up the end of the hose to one eye and look into it as if he thought I were inside of it, and as if he were trying to find me.

He tried to cultivate the acquaintance of the cat, but it was shy of him. His greatest ambition was to catch it and play with it, but it was afraid of him from the start, and they had some terrific races through the house.

Long says wild animals do not know

anything only what their mothers teach them; but he is away off the trail. When the cold winds of October began to blow Ben knew it was time to get ready for winter, though his mother died when he was 2 weeks old. He dug a big hole under the floor of the woodshed and carried into it all the old clothes, rags, shavings and straw he could get hold of. In 3 days he had a good, warm place to hibernate, but the poor cub never got to occupy it.

The boys taught Ben to lie on his back and play with a football or a small keg, as you have seen a juggler do in a circus. The cub was as fond

back fence, pulled the staple from the barn door and went in to have some fun with Ben. He had grown to be a big bear by that time, yet the boys thought it would be perfectly safe to play circus with him as before. Ben was always ready for anything, and gave them a warm welcome. I learned the particulars of the interview on the installment plan. One boy told me a part of it, then another boy told another part, and thus it all came out.

It seems that at first one of the boys got on Ben to take a ride. This was all right, and Ben raced around the barn floor with him, *a la* circus ring. Then 2 of the boys got on. That was

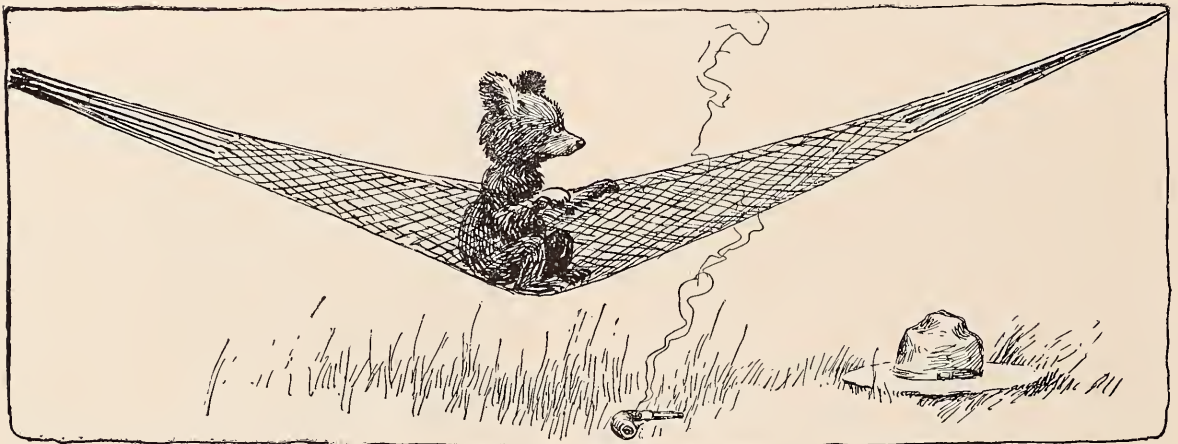

SOLID COMFORT.

of this kind of sport as the boys were, and would keep a football in the air 20 minutes without letting it touch the floor.

Finally Ben got too big for the house. At times he would depart from the gentle ways of his childhood and become decidedly rough in his play, so we had to relegate him to the barn at the foot of the lot. I kept the door of this barn securely locked, and would not allow anyone to go in unless I were there to *chaperon* the visitor.

All the boys in town had, of course, cultivated Ben's acquaintance before he got so big, and they still longed to romp with him. One Sunday afternoon when we were all away a dozen of these boys met at my house and finding it vacant climbed over the

all right, too, and Ben gave them a lively whirl. Then 3 got on. Ben was faithful to his training, and spun around the ring a few times with the trio. He finally got tired of that, concluded they were rather rubbing it in, and that he would change the feed on them. Suddenly he dropped on his back and commenced to play football with the boys. Two of them escaped, but the third was not so fortunate. Ben seemed to have doubled him up into a ring, a ball, or something of that kind, and set him spinning in the air. He kept that up until the other boys thought their pal was being torn to pieces, when they all rushed in and rescued him. They then went out of the barn with all possible speed.

The boy who had been the football, was a sight for the gods. His clothes were torn to ribbons and most of them stripped off him. His legs, arms, back and head were clawed and scratched and the blood was running from him in at least 50 streams. The yells and shrieks of the boys had brought a crowd of the neighbors. The victim was hustled into the nearest house, a doctor was called and the boy was sewed up, bandaged, bathed in arnica and put to bed. In the course of 3 weeks he was able to walk about, but it was nearly 6 weeks before he was fit to appear in company again. His father, meantime, had a big doctor's bill to pay, besides buying the boy a new suit of clothes.

Naturally, the old man was indignant. It happened that he was a bad man, and had confided to certain of his neighbors that he had killed a man some years before, in the mines. As soon as he learned of the damage to his young hopeful he said he would kill the bear and if the owner made any objection he might share the same fate. When I returned home that evening I went to see the boy, and several of the neighbors came in to see me. The affair was, of course, the talk of the town for weeks. Within a day or 2 after the accident, the old man called on me and ordered me peremptorily to kill the bear. I said I did not think I would. Then he said,

"If you don't kill him, I will." I said,

"I don't think."

Fortunately, I am bigger than the old man, and younger, so he did not think it best to carry out his early

threat in the matter. He looked up a policeman and tried to get him to kill the bear. The officer declined. Then the old man called on a justice of the peace and asked for a warrant for my arrest. The justice asked him some questions, and after investigating the matter carefully, declined to issue a warrant. He, however, sent for me privately, and I called on him. He asked me to tell him all about the affair, and I did so. He asked me if the bear had been off my premises at any time, and I said,

"No, not since I brought him to town." I then told him I had at first kept Ben in the house and since he outgrew that, had kept him in the barn, with the door securely locked; that the boys had gone to the barn, broken into it, and had met their Waterloo. The judge said he could not see that I was to blame in any way, and that if the father of the young hoodlum made any further threats against me, to come to him, and he would issue a warrant for his arrest; so the football match rested there.

I realized, however, that Ben had outgrown my town lot, and that I must part with him. I dreaded this ordeal for I had grown extremely fond of him; but I was not prepared to establish a zoological garden or to build a bear den. It happened that a circus visited the town within 2 or 3 weeks after the football game, so I called on the manager, and asked him if he did not want a black bear. At first he said no, but when I offered to give him one, he said that was different; so I led Ben down, consigned him to the animal keeper, bade him an affectionate farewell, and I trust he is still alive and happy.

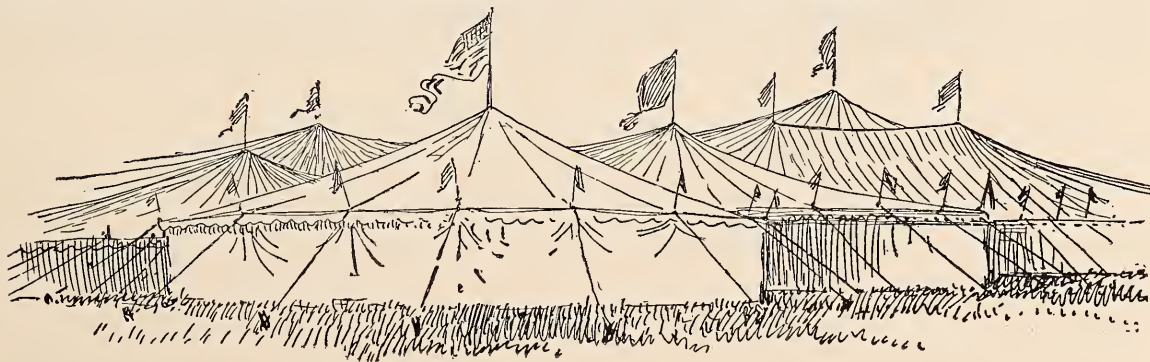

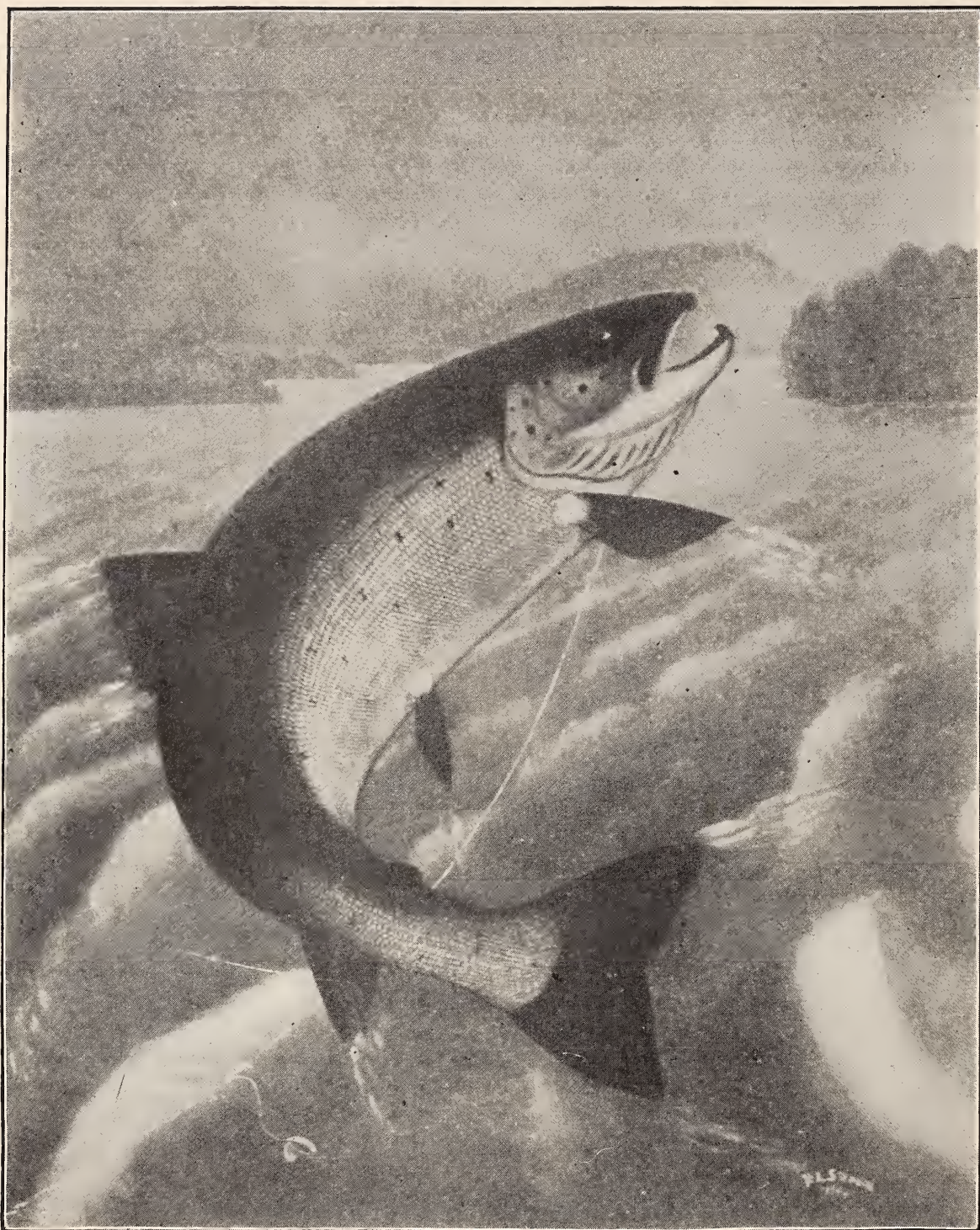

A THRILLING LEAP.  
(Land Locked Salmon)

FROM OIL PAINTING BY W. L. STEWARD.



## THE BREAD OF IDLENESS.

ROBERT P. LOWRY.

Easily and lightly our canoe glided down the gleaming Susquehanna, as our eyes traversed the banks in search of a camp site. A dancing line of white water ahead abruptly terminated our search. The canoe yielded to the quickening current and awakened to new life. Not to have shot a rapid is almost not to have lived; and he who has never known the mad, wild joy of it is fortunate only in that the future holds so rare a delight for him. Through the deep, swift water, down the triangular tongue at the beginning of the riffles and onward between great rocks, whose presence was made evident only by a foamy backwash, our boat, guided by the steady arm of Red and Blue, sped like a flushed

town, at the head of the river, to that place; and there our river adventures were destined to end, for the rocky bottom of the shallow river had completely worn the canvas off the bottom of our canoe.

We entered on a quiet, uncolored manner of living such as is attained only by great philosophers, tramps and a few campers. The gospel of this state is contentment. To be at peace with all the world; to banish dreary cares; to have the *wanderlust* silenced by long, hard days of paddling; that is to dwell in Arcadia.

Sometimes the man that owned the farm on which we were located honored us with a visit. Another welcome guest was his helper, Gus. He was innocent of the 3



ON THE SUSQUEHANNA.

AMATEUR PHOTO BY LEWIS E. THEISS.

quail. A sudden bend of the river to the left and we found ourselves in the place we had been seeking.

A huge chestnut tree rose a few rods from the bank, overshadowing a wide stretch of grassy meadow. Under its branches we pitched our tent. In the farm house, near, the good dame freely gave us permission to camp on her husband's land; but the sight of our bare, sunburned arms stirred the mother in her. She recommended cold cream, and related warningly a story of a little boy who came to his death through sunburn. Our camp lay in a narrow, basin-shaped valley divided by the North branch of the Susquehanna. On the opposite side of the river was the town of Windsor. A week of canoe cruising had taken us from Coopers-

R's and he had had to work hard all his life. His sole diversion had been, so he declared, an occasional fishing trip; but he was good natured and clever.

Sometimes the boys from the town swam the river and came unashamed up to the tent. To these we let it be known that our canoe was for sale. Not that we really wished to part with our alternate servant and mistress, but to see a horny handed tiller of the soil in that *varium et mutabile*, canoe of ours was ever our desire.

To the inhabitants of the hamlet across the river we were a mystery. The brown trousered tramps with the gray flannel shirts who, according to their own statement, were not fishing, and who bought food at the store in place of soliciting "hand-outs" at the back doors, were phe-

nomena for which even the most imaginative of the gossips failed to account.

We swam in the afternoons, and once we went fishing. This last step we took only after much deliberation. It was a bit strenuous to harmonize with our manner of living; but half a day spent by the river's brink, rod in hand, resulted in a considerable string of bass and sunfish.

Our ears were charmed by the song sparrow's matins and vespers; our eyes were delighted by the sunset light on the water,

and the afterglow that clung lovingly to the hills. We were content to loaf and dream and smoke by the stream; and if the rain gently falling on the tent was our slumber song, it troubled not the peace of our souls.

Even golden days are not immortal. The time came when we had to leave our happy valley; yet in spirit we often and fondly return to that lotus land, where an earthly Lethe went on its sparkling way past our habitation, and where we ate and found sweet the bread of idleness.



AMATEUR PHOTO BY J. BAUER

CHIPMUNK.

One of the 16th Prize Winners in RECREATION'S 7th Annual Photo Competition.



AMATEUR PHOTO BY J. BAUER.

RED SQUIRREL.

One of the 16th Prize Winners in RECREATION'S 7th Annual Photo Competition.



AMATEUR PHOTO BY A. L. PRINCEHORN.

ROBIN AT NEST.

One of the 14th Prize Winners in RECREATION'S 7th Annual Photo Competition.

## PHOTOGRAPHING IN THE MORO COUNTRY.

GEO. D. RICE.

Photos by the Author.

In the island of Mindanao, the Moro Mohammedan tribes, numbering hundreds of thousands, were invincible. Previous to the expedition of American troops which penetrated to the heart of the island in April, May, June and July, 1902, white man had never ventured there. General Weyler and his regiment reached the Lake Lanao regions of Mindanao about 3 years ago, to attempt to pacify the unruly Moros, but he did not remain long; and so it has been with all others who have tried to force a passage into the interior. The fierce fight-

gave out I went among the thousand or more soldiers, offering fabulous values for one or more films, but only 2 or 3 men had cameras and they were down to the last film.

Campaigning, with the enemy firing at night, with short rations, long marches, and in heavy rains, is not conducive to good photography. I secured some excellent views of the capture of stockades, of the blowing up of fortifications, and the like, and carried those films inside my shirt; but the penetrating rain soaked me through night after night; and later, when I turned my films over to a photographer for printing, he informed me that they had been reduced to pulp by the wet. The next time I go on an expedition of that sort I shall carry my camera outfit in a waterproof case. This is easy to say, but when on the march in the enemy's country, one drops everything but his canteen. When a soldier gives up all his personal comfort so he shall not fall back of the column and into the hands of the foe, he is quite sure to drop his extra weights in parcels; yet in this struggle of a 3 or 4 months' campaign I know of only one camera being abandoned, and that was partly because it got wet and warped.



NATIVE SOLDIERS.

ing warriors of the Moro tribes were aggressive and destructive to life and property. It was decided to punish them, and the column was formed under Colonel Baldwin which finally made things peaceful in the lake sections of Mindanao. I was with the Baldwin expedition. We captured Moro fort after fort and destroyed their works and barricades. May 2nd, the great fight of Bayan, in which we lost 2 officers killed, 8 enlisted men killed, 3 officers wounded and some 55 soldiers wounded, finished the Moro army. Since then it has been content to let our sentries alone and cease stealing our horses and properties. The result is that the man behind the camera can go where he pleases.

Why did I not get some views of the battles? One can not carry much on a horse, and when hiking it is all a man can do to carry his shelter half and roll. We were often short of everything, there were long marches, there was no wagon transportation, and often the mule pack trains were far in the rear. Yes, I had my camera and a supply of films, but not nearly enough. When the first lot of films



NATIVE BATHING GOWNS.

I am preparing for the next campaign in the wet, where I may have to lie on the ground with a shelter half over me and get thoroughly wet before sunrise next day. A native is making me a waterproof case which will hold my folding Kodak and about a dozen films. This case will fasten tight to my side, at the waist, where it will not interfere with haversack or canteen.

The army ought to have more photog-

rappers. There was a time when the photographer was ridiculed, but not so now. Those who had cameras in that campaign were requested by officers and enlisted men alike to provide copies of all views at any cost. I enjoyed taking views more than I ever enjoyed anything else. The fact that I had a camera made the campaign like a big holiday to me. It drove the blues from me completely, relieving the monotony, even though many of the films were spoiled.

A campaigner can make considerable money with his camera in these foreign lands if he secures the right views and retails them to his friends. I like to give my comrades prints of their camps, their fights, and the like, at cost, but these liberal and independent fellows will not let me. I say to a soldier friend, "Here is a view I took, and I see that you are in it. You may have a print at the cost price, perhaps 10 cents." He delightedly accepts a print, but insists that I take 25 cents for it. I do not like to take money from my comrades, but they make me.

The natives also like the views. They do not concern themselves about the price. You can gracefully present a print to a native, say of his house, with himself seated in front, and his family in the background. He receives the view with a grunt and a smile, the little ones play with it and soil it, and you think your generosity has gone to waste; but by and by this native comes to your quarters with a parcel. You open the parcel and it contains for you a present of a bolo, a spear, or some relic that you value at many dollars.



UNDER THE BAMBOO TREE.

The natives are amusing. Few of them are unaware what the photographer is doing when he snaps them. By instinct they know, if not otherwise. The women hide their faces if in working attire, but if in Sunday togs they proudly pose for the view and are pleased if they are snapped several times, although they may never expect to see the prints. Moro women have often kept me waiting a long time at the door until they arranged themselves for being pictured in American costumes. They will give you no peace until you have the film developed and give them a print. Then they have great sport over it. They ridicule the size of one another's mouths and the like, and it is worth dollars to hear them. Soldiers and others who wish to make life worth living while serving with a regiment should take their cameras with them.

## A PLACE JUST EAST OF PERSIA.

A. L. VERMILYA.

Ship me some place East of Persia, where  
no callow writers dwell,  
Where no bloomin' poetasters stupid tales  
in verses tell;  
Where the editors are cranky, and all manu-  
scripts decline  
That have in their addled make-up even one  
poetic line.

For I'm tired of all this rubbish—tired as  
ever I can be—  
When I ope my RECREATION, this is what  
I'm sure to see:

"There's a place a mile from Kansas, that  
is most divinely fair,  
Where the Indians are peaceful, and will  
let you keep your hair."

Ship me some place East of Persia, where  
they shoot the writer man,  
Where they pitch the budding poet from the  
desert caravan;

For it gives me indigestion, cholera, and  
fits, sometimes,  
When these mushy, gushing scribblers split  
themselves in bummy rhymes.

And when my short hike is over and my  
spirit sails away,  
Plant me somewhere, I beseech you, where  
no spiffling bards can stray;  
Where no magazines are published, and no  
unfledged rhymesters peep,  
There amid great hunks of silence let me  
take my dreamless sleep.

"Hold on, Quaker, stop your kicking!" this  
I say unto myself,  
As I lay my pen and tablet thoughtfully  
upon the shelf;

"Though these poets in their frenzy write  
some most atrocious verse,  
It is evident as can be that my rhymes are  
even worse."

## THE HAWK BOUNTY QUESTION.

J. E. TYLOR.

In December RECREATION Mr. W. T. Hornaday gave some valuable advice relating to the hawk bounty subject. Those who advocate such a policy, hoping thereby to exterminate hawks and owls, should read what this eminent authority has to say. Mr. Hornaday does not indulge in speculation when he advocates the protection rather than the destruction of certain hawks and owls. On the contrary, the matter having been scientifically investi-

all counted alike. This spirit of destruction even extended to the fish hawk and its nest of young; until it cost the taxpayers many thousands of dollars and the law had to be repealed or the county become bankrupt.

Last spring I visited a nest of the barred owl. It contained 2 young birds a few days old and one spoiled egg. There was also in the nest a bountiful supply of provisions for the rapacious appetites of the



AMATEUR PHOTO BY J. E. TYLOR

YOUNG BARRED OWLS AND THEIR MORNING BREAKFAST.

gated, no longer stands on theory, but on established fact; the final judgment being to kill the Cooper hawk and the sharp shinned, but to regard the others, generally speaking, as more beneficial than destructive.

In Talbot county, Maryland, several years ago, a bounty of 50 cents was paid for every hawk and owl head, regardless of kind. School boys searched the orchards for hollow trees wherein the little screech owl might dwell, and before taking the life of the parent bird, frequently waited for the eggs to hatch, that the whole family might be sacrificed, as little heads and big heads

young birds. These consisted of a grey squirrel, with its head eaten off; 4 field mice, 2 being partly devoured; one wood rat, head eaten off; and 2 garden moles. These I photographed, and though unfortunately I did not secure a satisfactory negative, nevertheless it gives a truthful bill of fare. The squirrel was still warm, while the 7 rodents were freshly killed. If that represents one meal, how many pests will a pair of adult owls destroy in a year?

I submit the enclosed picture as some evidence, at least, that the barred owl has a just claim for friendly consideration.

Palette—De Auber is an odd genius.

Brushly—What's he up to now?

Palette—He is painting a \$300 portrait of a 30-cent man.—Chicago News.

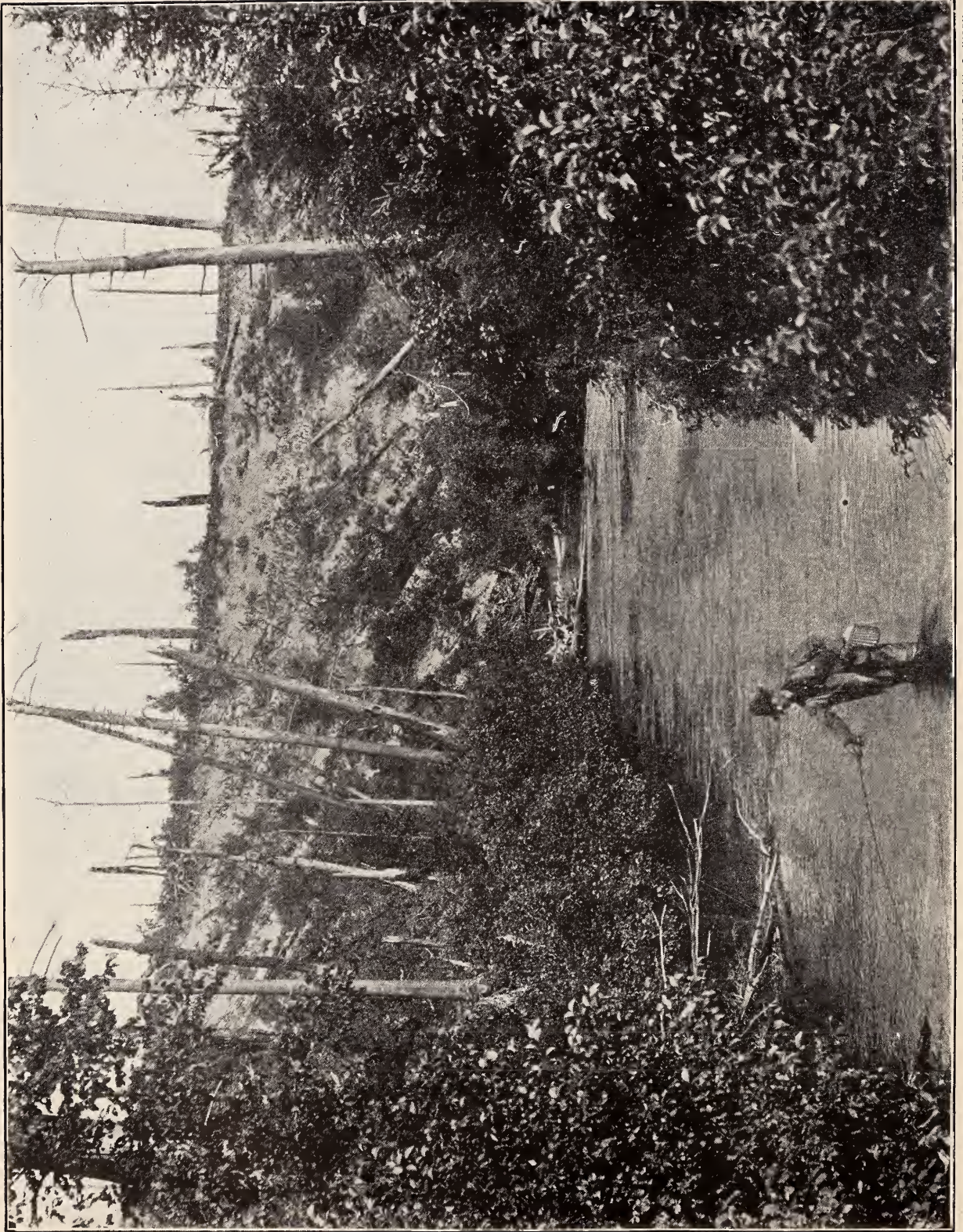

AMATEUR PHOTO BY W. S. KIRBY.

HOME OF THE BROOK TROUT.  
Winner of the 30th Prize in RECREATION'S 7th Annual Competition.

## WITH A PEELED POLE.

FREDERIC BIGELOW.

Over the lapse of years I can vividly recall my first experience in trout fishing. Nothing in the past has so deeply rooted itself in my memory. Even the remembrance of the boyhood times when I had to hoe corn or to pick up potatoes on pleasant days, or to saw wood in the shed, or to sprout potatoes in the damp cellar on rainy days, has nearly faded; but my youthful fishing days are still fresh in my memory.

It was in early June when my uncle permitted me to accompany him trout fishing for the first time. The trees were in leaf, the violets in bloom, and all nature was rushing forth to meet summer. As we were to go before sunrise of the next day, I was sent early to bed so as to be ready for the morning walk to Long Lake creek, the favorite trout stream of the neighborhood. How long it took me to go to sleep that evening! When finally I did, I dreamed all night of the trout I was to catch on the morrow.

I was a small, freckle-faced lad, full of hope and wonder. I wore an old straw hat, well ventilated, a calico shirt, a pair of homemade trousers, and went barefooted. To wear shoes and stockings during the warm weather was the surest and quickest way for a boy to lose his social standing among the other boys. With this apparel it took me about as long to dress as it did to repeat twice 2.

The tackle I possessed would make a boy of today smile. Jointed rods, automatic reels, landing nets, and gorgeous flies of many kinds and colors were unknown to a boy of my time. My tackle was simple and strong; everything was homemade except the hook and line. My rod was a peeled ironwood pole, cut from the forest; the line, of white cotton, was little less than a rope in size; and the hook was a large black one, baited either with a wriggling angleworm, a minnow, or sometimes a frog's leg.

The grass was heavy with dew and the Eastern sky was reddening when my uncle and I walked over the meadow and pasture lands and the rolling, sandy road which led to Cooper lake. This lake covered a few hundred acres, its greatest width measuring about half a mile; and on its surface arose a small island dotted with clumps of trees and bushes. The banks of the lake were almost encircled by a forest. We crossed the lake in an old, flat bottomed boat and the creaking of its long, clumsy oars echoed and re-echoed

weirdly through the surrounding forests. When we came to Long Lake creek, which discharged its pure, clear, cool waters into Cooper lake, we met an irritating difficulty. As the creek's banks were covered with an almost impenetrable thicket, it was impossible for us to land without dragging our boat up the stream until we came to a clearing. In working our way through the network of bushes and vines we were often struck in the face and eyes. I never before had seen my uncle impatient, and I am fearful he used language foreign to his customary speech and improper for a boy to hear. Finally, however, we came to a clearing, in which we left the boat.

From the clearing to the falls of Long Lake creek was about 2 miles. Above the falls the stream was sluggish, but below them it wound through a beautiful forest, and the music of the sparkling waters dancing over the boulders was a delight to hear. In this part of the stream were the favorite haunts of the trout.

Along the banks great trees grew and beneath them the water had washed out deep recesses or pools. In those dark, deep pools my uncle said the trout were. He told me to fish in every deep hole, beneath every log, beside the large boulders, and in all places which looked favorable as a trout retreat. He even kindled my imagination by telling me if I fished carefully and made no noise I might catch a large, cunning old fellow, who lived a solitary life, although I ought to be content if I caught the smaller fry.

For reasons then unknown to me, my uncle fished up the stream instead of beginning at the falls and fishing down. He told me to follow him a distance up the brook and to watch his method of fishing. I followed, watched, and made as little noise as possible, although I occasionally fell among the bushes or sent something splashing into the water. It seemed to me that he had a trout dangling from his line at almost every cast, and when I left him to try my luck, he was stepping from stone to stone and swinging his rod in the air.

When my uncle was out of sight I tried my hand at casting, but I made a woful failure of it. I could not skim the bait over the water and my hook was always catching on the shrubs and bushes or into my pantaloons. Not a nibble, much less a strike, did I receive through my efforts. Determined not to give up without further trials, I wandered up and down the creek,

dropping my bait wherever I thought there was a possibility of landing a trout. I had no success. I felt that trout fishing was a sweet delusion, and, tired, discouraged and heavy hearted, I was tempted to give up in despair. I should have done so had I not been fearful that my uncle would never again take me with him. Therefore I kept on fishing.

I must have strolled for hours from one part of the brook to another before I came to a huge elm tree beneath whose twisted roots there was a deep, black pool. I noiselessly crept up behind the elm and dropped my hook into the pool. Instantly there was a tug at my line. How excited I was! What a thrill of joy passed over me! I jerked my line from the water as hard as I could, expecting to have a trout as large as a sucker on my hook. I fell backward, my pole flew into the air, and my hook caught among the overhanging branches of the elm. There was no trout. My hook must have caught on a root of the tree. I sadly scrambled up and disentangled my line from the elm's branches. Then I re-baited my hook and again dropped it into the pool. Again there was a jerk at my line. Ah, it was not a root that time, for I saw the gleaming sides of a trout as he darted away beneath the tree.

How he pulled! I yanked my line from the water and sent him flying from my hook into the air. He landed on the sand several yards from me, and near the banks of the brook, which was, at that spot, shallow and narrow. I instantly dropped my pole and ran for him, splashing through the water, and when near him I fell on him, just as he was about to flop into the brook.

I tenderly took up my trout and examined him. What a beauty! He was as delicately marked as a piece of rare china. He was considerably over a foot long, I felt sure, and must have weighed over a pound.

I cut a forked branch from a tree and strung my trout on it. Hearing a noise behind me, I looked around and there, watching me, stood my uncle with a large string of trout.

"Well! Well!" he exclaimed. "Where did you catch him? Why, he's bigger than any I've caught today!"

I told him. I was bursting with pride. "It beats me what luck these youngsters have," he muttered as we wended our way down the stream toward our boat.

My weariness was gone, and I was one of the happiest boys in the world, for I had caught the biggest trout of the season.



AMATEUR PHOTO BY A. N. FLINN

CURIOSITY NEARLY SATISFIED.

Winner of the 25th Prize in RECREATION'S 7th Annual Photo Competition.

THE SEAGULL.

EDITH M. CHURCH.

Skimming the wave with pinions free,  
Sailing far out o'er the restless sea;  
Soaring up to the bending sky,  
Courting the cloudlets drifting by;  
Then down again till your snowy breast  
Kisses the foam from the green wave's  
crest;  
Fearless and free you onward go,  
Scorning the dangers that lurk below;  
With nothing to guide your onward flight,  
Yet swift and sure you go through the  
night.

And I, far out on life's great sea  
Would guide my bark as fearless and free  
Through wind and wave, nor turned aside  
By gathering storm or treacherous tide.  
Trusting the Power that marks your  
course  
On the trackless sea, with compelling force  
Will guide me through the storm and  
night,  
'Till I see through the mists the harbor  
light.



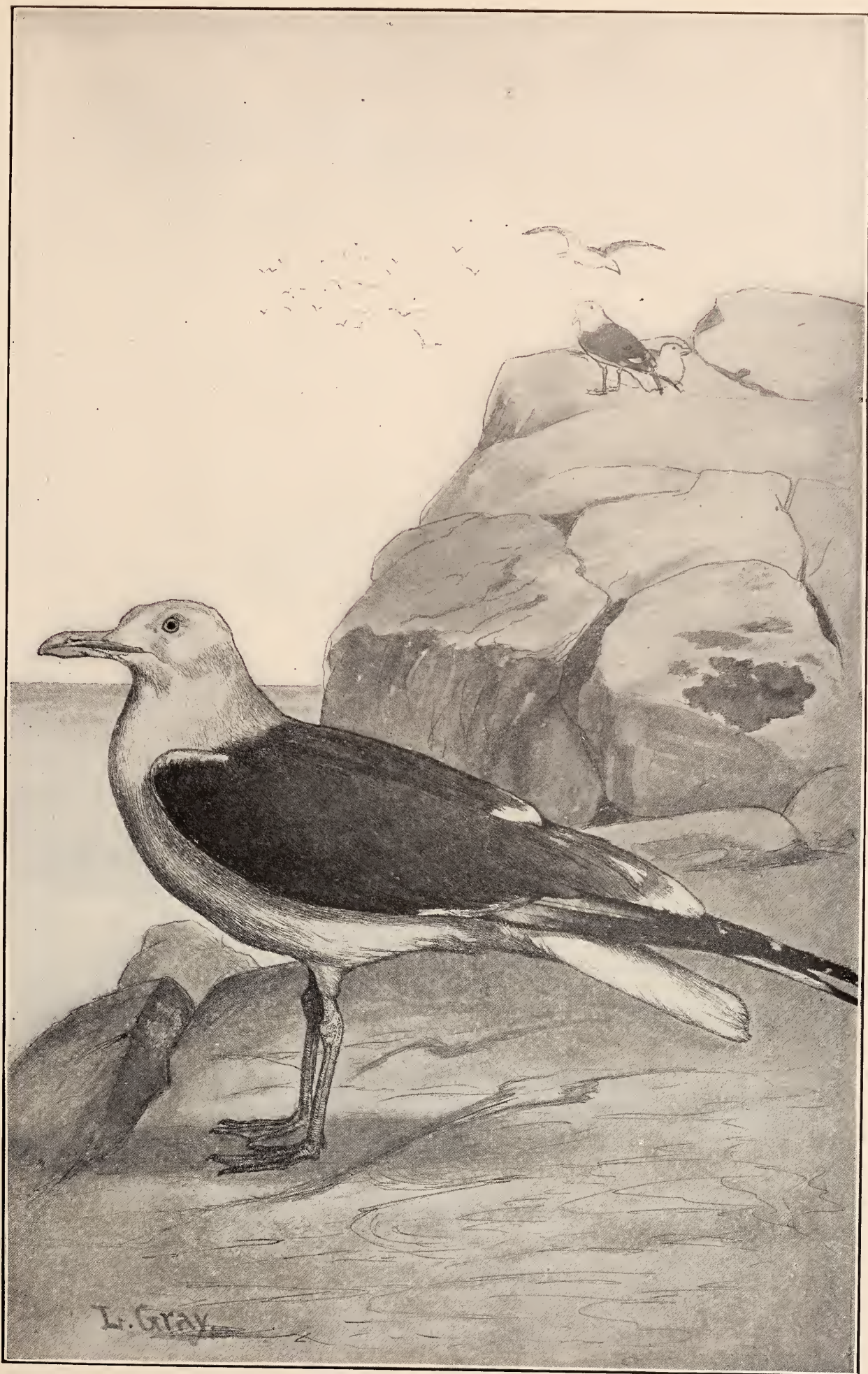

SLATY BACK GULL. *LARUS SCHISTISAGUS*.

## A STUDY OF FEATHERS.

MARY M. CALDWELL.

I spent 2 years in the far West. My home was not 20 miles from Seattle and near Lake Washington. My husband and brother had been quail hunters in Kentucky, so they were not long in discovering many ducks in the lake and grouse in the great forests back of us. There was large game, too. Bear had twice been seen near our house, but in that kind of game I was not interested, except to keep as far from it as possible. I did become much inter-

turned from a day's sport I had a double interest in seeing the game bags emptied; that of a good dinner and adding new specimens to my collection of feathers.

I came in possession of a quantity of rare feathers in an unexpected way. There came to our house one day a man who had lived and hunted in that country many years. I mentioned my collection of feathers, and he told me he had saved a great many to use for making artificial flies for

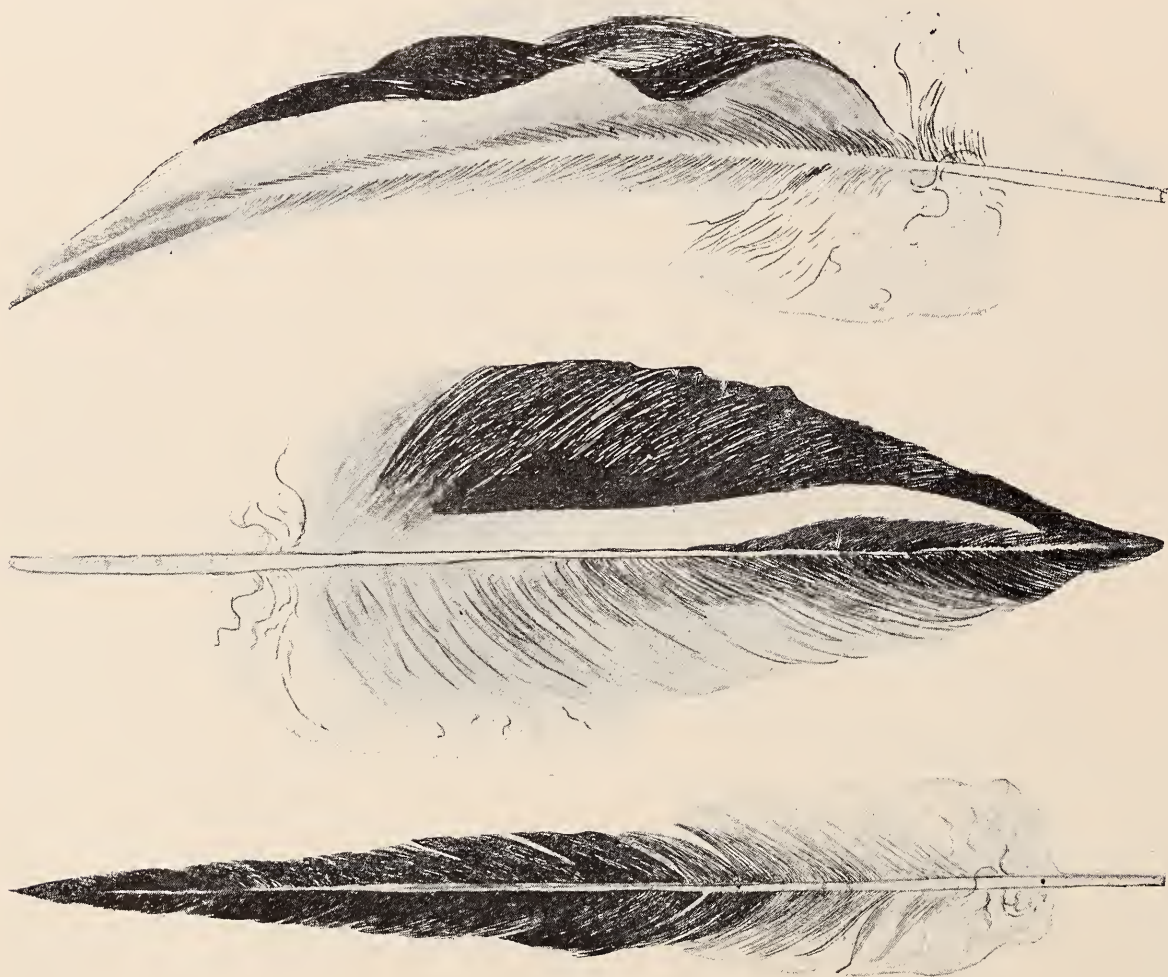

PINTAIL DUCK FEATHERS.

ested in the birds, not as an ornithologist nor for the adorning of bonnets, but because the birds were beautiful. I treasured the feathers as I did the rare mosses of that country. When the hunters re-

turned from a day's sport I had a double interest in seeing the game bags emptied; that of a good dinner and adding new specimens to my collection of feathers. I came in possession of a quantity of rare feathers in an unexpected way. There came to our house one day a man who had lived and hunted in that country many years. I mentioned my collection of feathers, and he told me he had saved a great many to use for making artificial flies for

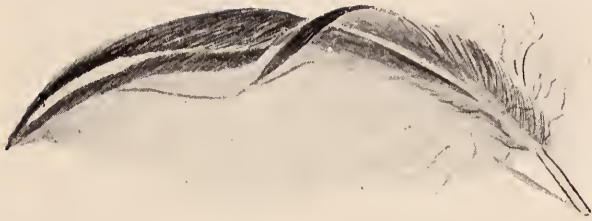

I have never seen such beautiful mosses as those of the Northwest. The ground moss I pressed in the usual way; but the

tree moss I treated as seaweed, letting it stand in water over night, then floating it on paper. This tree moss is not especially attractive during the dry season, but when the rain comes, it hangs from the trees like the Southern moss. Being a lovely green it is, however, far more beautiful.

The mosses and rare feathers, mounted on water color paper and looking like paintings, made Western souvenirs for many friends across the Rockies.

---

## W'Y DE FISH DON' BITE.

EDWARD BONNEL.

It's mighty ha'd ter splane w'y de fish  
don' bite  
W'en dis niggah's ben a-fishin' wif 's tackle  
jes' right;  
W'en er ripple's on de watah an' de win's  
Sou' West,  
En he done know how to kotch 'em erlong  
wif de best.  
Sing O! Miss Mandy.

Ef hit ain't in de rod, er de reel, er de line,  
Case de boat's too big, er de hook's too fine;  
Er de sinker's too hebby, er 'e didn't brung  
er net,  
Den de po' ole man ain't learned how yet.  
Watch out, mah chillun.

Praps de win's cuttin' capahs, er de sun's  
too bright,  
Er dis po' tired niggah's played craps all  
night.  
P'raps dey's lonesome en quit bitin' case 'e  
kim so late,  
Er dey mos' all wanted er different kin' o'  
bait.  
Oh! don' git weary.

I's cast de Colonel Fuller wif de Par-  
machene Belle,  
En den de Royal Coachman wif Jenny Lind  
as well;  
But dey wouldn't tak' de las' nor rise to de  
fust,  
En de possum up de 'simmon tree laugh  
till he bust.  
I's comin' home, Dinah.

I's happy wif mah wum can w'en I think it's  
gwine ter rain,  
En ef de sun comes out w'y I 'low I cain't  
complain;  
But I loves ter heah de catfish sizzling in  
de skillet,  
An' O bless mah soul! I sholy hopes ter  
fill it.

But w'en it ain't in de weathah, ner yet in  
de bait,  
En hit ain't case I started jes' a leetle too  
late;  
Den I knows hit's de rabbit's fut am sholy  
ter blame,  
Case I done clean fergit um en I's sorry I  
came.  
Good by, mah honey.

---

Mrs. Noorich—Isn't it grand to ride in  
your own carriage?

Mr. Noorich—Yes, but I'd enjoy it more  
if I could stand on the sidewalk and see  
myself ride by.—Brooklyn Life



AMATEUR PHOTO BY ERWIN R. LOGAN.

*THE FOILED REPOISTE.*

One of the 31st Prize Winners in RECREATION'S 7th Annual Photo Competition.

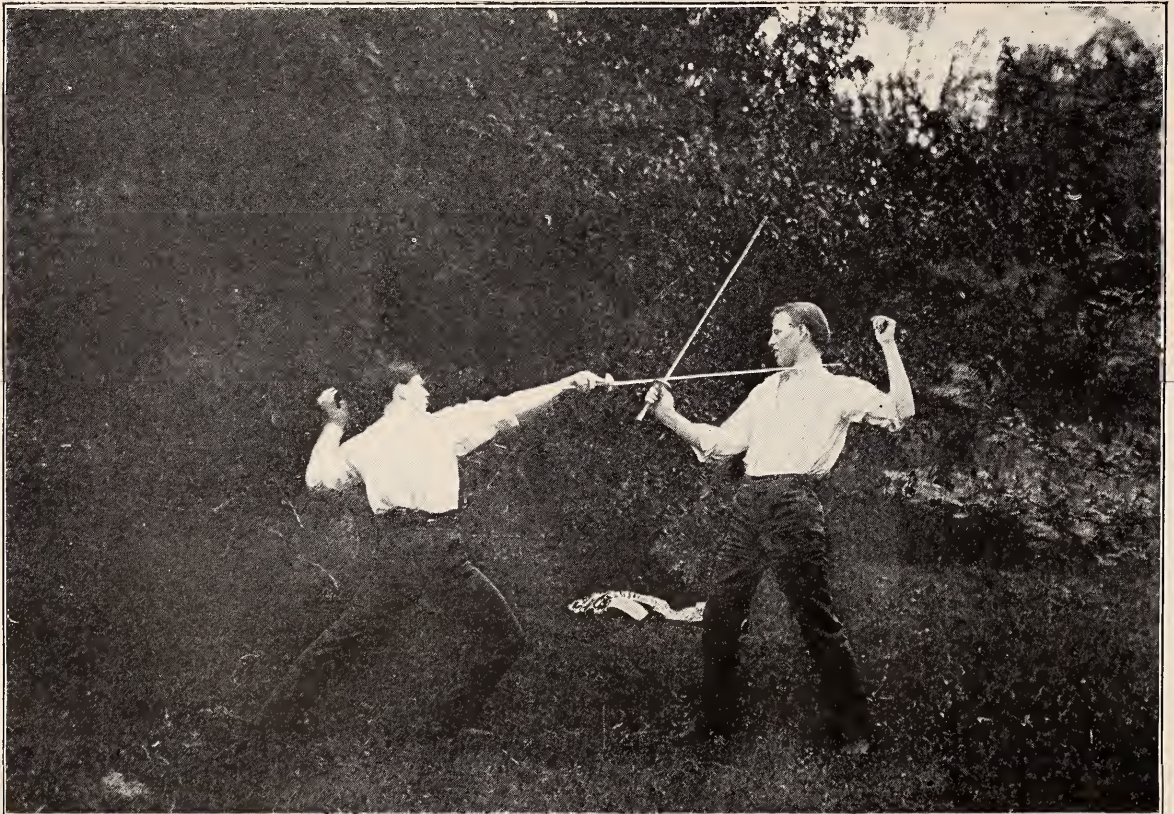

AMATEUR PHOTO BY ERWIN R. LOGAN

*A NARROW MARGIN.*

One of the 31st Prize Winners in RECREATION'S 7th Annual Photo Competition.



AMATEUR PHOTO BY ERWIN R. LOGAN.

### A GRAND STAND PARRY.

One of the 31st Prize Winners in RECREATION'S 7th Annual Photo Competition.

## WHAT WOULDN'T I GIVE.

A. N. KILGORE.

What wouldn't I give  
 T' jes' go back whar I used t' live,  
 An' be a little tad agin,  
 With a freckle face an' a foolish grin,  
 A stubby nose an' a stone-bruised heel,  
 An' a thatch th' color o' Indian meal;  
 Black an' blue spots on each leg,  
 An' go by th' name o' "Turkey-Egg";

T' range aroun' from break o' day  
 Till Natur' put th' sun away;  
 T' loaf thar by th' swimmin' hole  
 With that ole bent pin an' alder pole;  
 T' hear th' bummin' o' th' bees,  
 An' th' wind astirrin' th' willer trees;  
 T' know th' birds an' fish an' toads  
 Like I knowed th' stumps in th' ole wood  
 roads;

T' live jest like I used to do  
 In barefoot joy th' summer through;  
 T' see th' world with childish eyes,  
 When all was truth an' none was lies;  
 An' life was jes' as sweet a song  
 As th' one th' woodthrush sings at dawn.  
 Ef I could do jes' that agin,  
 I b'lieve I'd give mos' anythin'.

## THE JACANA.

L. P. GRAY.

One of nature's best examples of adaptation of bird life to its surroundings is seen in the Jacana family. In this, as in many other species, the appearance is, in a measure, an index to the habits of the bird. The food of the Jacana consists of aquatic insects and vegetable matter which it obtains by walking on the lily pads and other large-leaved aquatic plants. The pe-

tailed Jacana is found. The Mexican Jacana (*Parra gymnostoma*) inhabit Central America and Mexico, also just entering the United States on the borders of Texas. The common Jacana (*Jacana spinosa*) is a native of Southern America. This bird is well armed with that curious spur or claw on the wing which naturalists tell us "is developed at the radial side

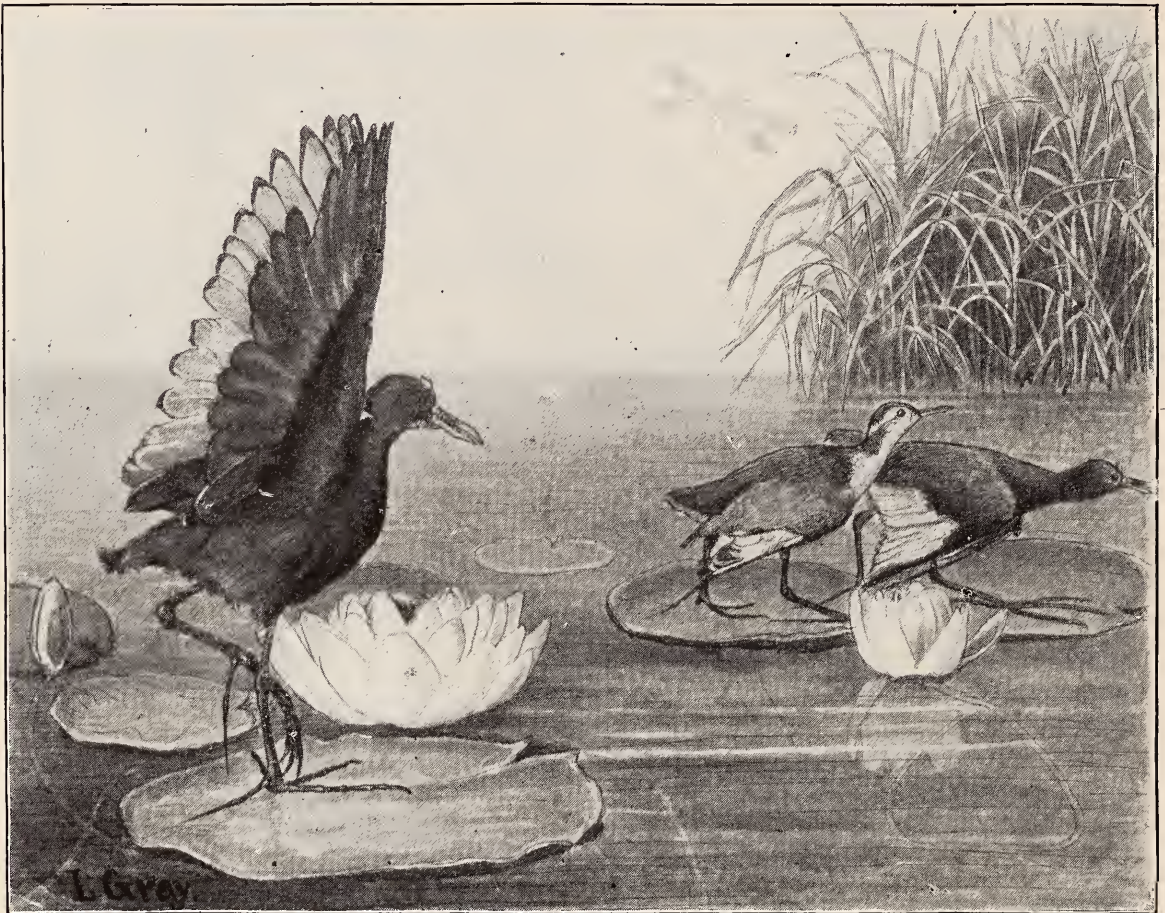

MEXICAN JACANA.

culiar shape and size of the feet make this possible. The body of the bird is rather small and is supported on slender, stilt-like legs with immensely elongated feet, furnished with straight nails. The wire-like toes distribute the weight on a sufficiently large surface to support the bird on thin, soft leaves. The Jacanas form a small family of tropical birds which are closely allied to the plover. Several species inhabit tropical America. Another genus is Indo-African in its distribution; another Malayan, while in India and the countries to the East, including the Philippine Islands and Formosa, the pheasant-

of the first metacarpal." This is used as a weapon by these birds of quarrelsome disposition. In some other species the spur is small and blunt, but an extraordinary development of the wing bone compensates for a real spur, as a severe downward blow can be dealt by this substitute. The common Jacana is a good swimmer and is shy and difficult to kill. They are generally seen singly, but in the morning and evening feed in flocks. When flying the long legs are thrown out horizontally, after the manner of the heron. From a curious habit of stretching up the wings until they meet over the back it would

seem that the Jacana is vain, and pardonably so, of his beautiful black-tipped greenish yellow wing feathers. The head and neck are black with a green gloss, the body and wing coverts a deep chestnut. A set of 4 eggs of this species are described as being of "a rounded oval shape, having a ground color of bright drab and marbled over the entire surface with an interesting network of black lines. The markings curve and wind in various ways, always in rounded, never in angular, turns, and the eggs present a peculiar, unmistakable and characteristic appearance."

Unlike the typical short-tailed American bird, the pretty Chinese Jacana (*Hy-*

*drophasianus*), or water pheasant, is a peculiar looking bird, having long, graceful tail feathers, carried like those of a pheasant. During the rainy season this Jacana builds a crude, flat nest in flooded districts where the lotus abounds, weaving grass and weeds in with some growing aquatic plant to retain it buoyant on the surface. The eggs are olive brown and the number 6 or 7. The notes of this bird are heard day and night, and so closely resembles the mewling of a kitten as to earn the title of Meewa from the natives. The flesh of this Jacana is excellent, and consequently it is in demand among sportsmen.

---

## POUNDING THE WRONG COON.

W. H. NELSON.

One evening in the 50's I spent a night with a school chum, and to get as much out of the evening as possible we decided on a coon hunt. My chum, John McGonigle, had a hound, Bounce, possessing a voice which made him famous in that region. It could be heard in South America.

A walk of half a mile across fields and woods took us to a wide cornfield, newly gathered. Across this flowed several small streams, whose banks were lined with briars and small trees.

Up one of these trees, a young ash, Bounce treed a coon, a whopper, as it proved. John generously delegated to me the honor (?) of shaking the game out, which I proceeded with much reluctance to do.

It took a good many swings to loosen the coon's grip on the top limb. I was almost directly beneath him, and fully expected him to drop on me, a fear which came perilously near being realized, for when he let go above, his claws scraped my back as he dropped. In my fright I almost followed him.

Once on the ground Bounce sprang nobly to work, and for a time there was such a tangle of snarls, squeals, yelps, and howls, such a bedlam of dog and coon, that I dared not come down lest I should alight on preempted territory.

The coon was too many for Bounce and after several rounds, we concluded to go to the aid of our ally.

But we had no gun, no ax, no club. Cutting, with much effort, a tough bough from the ash, keeping all the while my weather ear open for sounds of a renewal of the conflict, I came, at last, into the arena with a heavy, green club, hard to handle, but meant to carry death to the coon, if I could hit him.

It was a hazy, starlit night, and objects on the ground were mighty dim. Peeping carefully, and poking with my long club, I found the coon and proceeded to wallup him unmercifully, while Bounce, panting and resting, looked on.

Pounding away till I was sure I had broken every bone in the coon's body, and my own wind completely, I stepped aside to take breath. Just at that moment Bounce sprang on the coon in a different direction from the point of my battle, and a fresh and furious fight took place.

This time I watched and the moment Bounce retired, which he soon did, I struck, and fortunately hit the enemy on the head. The blow would have felled an ox, and Zip went down. For some time I continued to rain blow after blow on my unconscious victim and only quit when he was pulp. The object I had beaten so furiously before proved to be a tussock of sod.

Next morning we skinned our game. He weighed 19 pounds, and John Martin immediately told of one of his coons which weighed 25 pounds. We would have been glad to lead the record, but not by lying.



AMATEUR PHOTO BY PERRY ARCHIBALD.

A HARD ONE TO LAND.

One of the 32d Prize Winners in RECREATION's 7th Annual Photo Competition.



AMATEUR PHOTO BY PERRY ARCHIBALD.

MUSCOVY DUCK ON NEST.

One of the 32d Prize Winners in RECREATION's 7th Annual Photo Competition.



## MONTANA REMINISCENCES.

J. A. DUFFY.

In the summer of 1894 I was invited by Mr. Robert Swaim, the well known landscape painter, of Helena, to accompany him on a sketching and hunting trip into the hills in the Northern part of Deer Lodge county. We left Helena early in August and went to Avon, thence North into Washington gulch, intending to stay there about a month and then cross the hills into Jefferson and McLellan gulches.

Washington gulch is famous in the early history of Montana, because, with Alder and Last Chance, its name conjures up to the mind of the Westerner visions of untold wealth; but few traces of its former glory are left. Great banks of tailings and deep excavations tell of industry and sacks of gold dust; but these banks, together with the old deserted towns, are all that connect the gulch with the past.

The town stands as it did in the early 60's except that there are no inhabitants. The dance hall is still there but there are no dancers. Yet the American flag, which, perhaps, was hoisted during the Civil War, has never been furled. Its tattered folds still cling to the flag staff, but its colors are no longer visible. When the surrounding cabins shall have given way to the elements the town of Washington will have passed into history.

We went up the gulch about 2 miles and pitched our tent on the banks of a picturesque little stream. One evening I told Mr. Swaim that instead of accompanying him on his sketching trip I would go out prospecting. The following day, armed with a gold pan, a pick and a shovel I set out toward Jefferson gulch, about 2 miles from the camp. There I dug a hole about 10 feet deep and reached bed rock. The colors were not numerous, but I was well compensated for my labor because to the result of that day's work I owe my life. A band of cattle which roamed over the valley had become so wild that the sight of a man in the distance would frighten them into running. I saw them on many occasions and every time they fled promiscuously. On that particular evening they lay behind a knoll along which I must pass on my way home. In the absence of city entertainment might I not have some amusement, even if it were of the school-boy order? I would steal around on the other side of the knoll and beat the pan, like an Indian. The cattle, of course, would shake the plain in their efforts to get away. Theory and practice sometimes telescope each other and in this case the

collision was unusually severe. Every head in the band jumped up and snorted. Then they started, but I was the magnet toward which they were drawn. I confess I was rather afraid and, taken as I was by surprise, I stood there as speechless as a Montana Senator. I looked around for some object to which I might flee. The bare broad valley of Nevada creek lay before me.

Even the trees on the blue grey foot hills looked more dim and distant than usual. In a moment I was reminded of the prospect hole and toward that I fled, with a band of infuriated cattle behind me. Even as a bank cashier skedaddles to Canada so did I flee from my pursuers. To say I reached the bottom of the hole on schedule time would be equivalent to saying I was gored to death. In the matter of pace making I established a precedent. Having disappeared so suddenly the cattle seemed to forget where they were at and but for a little occasional bellowing, as if in play, I heard no more of them. When they had wandered into a ravine which led to the foothills I ventured to the camp in safety.

The next few weeks were uneventful; given chiefly to sketching and shooting coyotes, which are active in that part of the State. These animals are a nuisance to camp life. There is nothing they will not eat, from case eggs up to an axe handle. I have never heard of one's gnawing the inscription off a tombstone, but to a coyote nothing is so sacred it is not palatable. They are, though so familiar, a wary target to shoot at.

One night I sat up later than usual and as it was warm I took up a position outside the tent. When my companion retired he put out the light of the candle so everything was in darkness. It was a beautiful night. The light of the full moon was beginning to break through a depression in the hills at the head of the gulch, throwing a golden flood over everything. The stately pines whispered back soft words of greeting and the little brook seemed to chatter more pleasantly. While thus in a sentimental mood listening to the mysterious noises of nature, I was suddenly startled by the howl of a sweet voiced coyote. I waited for another, in order to locate my game and was agreeably surprised to find him sitting on a pile of castellated rocks, sharply silhouetted against the moon. Whistler would have called it an arrangement in black and gold, but to me

it suggested nothing so vividly as a splendid opportunity for a cowardly hunter. Stealing into the tent I picked up Swaim's old Springfield rifle, which, by the way, was a relic of the Nez Perces war, and, resting it on a nail in the tent pole, took deliberate aim at the arrangement and fired. The landscape painter from Helena, ruthlessly divorced from his dreams, jumped up in bed, discharging questions at me about the color of their war paint and the particular tribe to which they belonged. I told him what had occurred and started out to throw the carcass over the cliff as otherwise it would make living intolerable. I confess I was rather chagrined when I reached the spot to see the coyote cantering listlessly into the night, while the moon still climbed the crystal walls of heaven.

Some time afterward snow began to fall in the hills at the head of the gulch and I embraced the opportunity it afforded to go deer hunting. Deer are quite numerous in that part of Deer Lodge county, notwithstanding the frequent raids which are made on them by the Indians and some unscrupulous white settlers. One morning, feeling unusually bloodthirsty, I started up the hillside toward McLellan gulch. When I reached the hill top, which looks down on the gulch, I sat down on a log to rest and enjoy the wealth of scenery unveiled by my new position. Deer trails were numerous and I took a fiendish delight in

the thought of how the full moon, looking down on the result of my marauding, would grow pale as he deplored the sudden decline of the deer industry in Montana. While thus engaged I was startled by the cracking of some underbrush which lay on the edge of a clump of quaking asp, directly behind me. I turned around sharply in an effort to stare a mountain lion out of countenance. I felt rather uncomfortable and restless. I like sociability but reserve the privilege of selecting my acquaintances. After the correct imitation of Spanish gunnery I had given some time before I was loath to throw down the gauntlet to so formidable an animal. Yet it would be unsportsmanlike to run away, I reasoned with myself, however, that since I started out to hunt deer I must confine myself to that species; that if a mountain lion intruded on my privacy it showed his bad taste and that I was not to blame. This argument was so convincing I lost no time in disengaging myself from that cougar. Under such circumstances it is a gross breach of discipline to look back over one's shoulder, but I allowed myself that privilege and was rather pleased to find the cougar going in the opposite direction, with much enthusiasm, and that we were separated by about 500 yards of excellent Montana scenery.

About the middle of November, the snow having become too deep for us to do anything with comfort, we returned to Helena.

### A REPROACH TO WISCONSIN.



DECATUR WALKER, LAKE GENEVA, WIS.

Here is a reproduction of a photograph of one Decatur Walker, of Lake Geneva, Wis., who poses as one of the "great fishermen" of that village. He is evidently proud of the slaughter or he would not have been photographed. Walker parades the dog in the picture as if he might have been an accomplice, but the latter seems to have more sense than his master, for he looks away from the camera, and is evidently ashamed of the butchery perpetrated by his boss.

Walker's number in the pen is 877.—  
EDITOR.

"I don't think much of this museum," said Jinks. "They ain't got no skull of Napoleon Bonaparte, and the one I was in, up to New York, has 2."—Baltimore American.

She—You say you are devoted to art. What is the particular art that you love best?

He—Thou art.—Kansas City Times.

## THE FLORIDA KID.

CHARLEY APOPKA.

### XI.

It seemed like ter me soon's I got ter sleep, pa shook me, an' sez, "Git up, son; git up an' help git breakfast."

It was cold as the dickens an' I shore hated ter crawl outen them warm blankets. I hopped out an' jumped inter my clothes, an' holp pa bake the biscuit an' fry the steaks, an' Mr. Sam tied up old Ring, an' put 14 catridges in 'is Winchester. We et a snack, an' put a plenty fer our dinner in our bags, an' lit out jest as it was a gittin' light in the East.

We went straight ter where we cleaned my deer, an' there was sign a plenty in the wet sand in the bottom of the ditch. Look like all kinds of varmints had been there; but Mr. Sam showed old Ring the painter sign, an' he bristled up mighty fierce an' sorter whined. Mr. Sam mitched 'im a little, an' he switched 'is tail, an' took off through the woods to'rds camp. He went within a quarter of it, an' then circled to'rds the big hammock, an' led into the thickest part of it. Old Ring begun ter git sorter excited when we come to a mighty thick place, where some big trees had fell down, an' we thought maybe the varmint was in there, but he'd hearn us a comin' an' had lit out, an' old Ring kep' on through, an' out inter the open woods again. It was sun up by then an' I was glad of it, fer it was cold as the mischief.

We run through a big bunch of turkeys, but we never shot 'em, fer we weren't after nothin' but painter that day. We kep' a goin an' kep' a goin' an' run plum out of the country where we'd been huntin' before. Pa said,

"If he keeps a goin this way we'll have ter quit 'im. We're ever bit of 10 miles from camp," but the trail begun ter circle 'round, an' directly we was goin' to'rds camp again. We jumped 11 deer, an' 3 bunches of turkeys, an' no tellin' how many poterges an' squirrels. Pa said it 'ud be a good place fer us to come nex' day to git our meat ter carry home.

Well, sir, that blame varmint come clean back an' went inter the big cypress swamp, a half mile from camp. Mr. Sam said the painter was a gittin' tired, an' I know I was. We entered the swamp erbout half after 2 o'clock. It was dry 'ceptin' in holes, but it was mighty bad travelin', 'casion of the cussed bamboo briers an' vines. Old Ring got way ahead of us, an' we didn't know which way ter go, so we stopped ter rest a minit, an' direckly we hearn 'im bay, way off in the swamp.

"He's treed, by grannies; he's treed," we all hollered, an' dashed on fast's we could go, fer we had ter be outen there by dark, an' I woulden fool yer. We had got nearly to 'em when old Ring breaks out a yelpin' like he was runnin' somethin' an' went a quarter further before he treed again.

"Dad burn it all," sez Mr. Sam, "he jumped out an' run when he seen us a comin'."

Pa said him an' me 'ud circle round, an' come up on the far side of the varmint, an' fer Mr. Sam ter wait till he hollered, and then we'd close up on the gentleman. It took pa 'n me a right smart while ter git around fer the swamp was so thick sometimes we had ter crawl under the briers ter keep from havin' our close tore offen us. There was lots of cat squirrels, the gentlest I ever seen. I don't reckon they ever seen a human before. When we was ready pa hollered, an' Mr. Sam 'sponded, an' we moved up to'rds old Ring. When we was in 50 yards of the dog Mr. Sam hollers an' sez:

"I kin see the ole scounle, an' gentlemen he's a whopper."

We moved to'rds 'im mighty keerful, an' then we seen ole Ring a prancin' about under a big cypress that had fell an' lodged in some other trees, an' up in the limbs was the ole varmint, an' he looked like the daddy of all cats. Ever 'casionally he'd growl, like thunder way off. Pa told Mr. Sam ter draw a bead on the burr of 'is ear, an' he'd keep his gun ter use on 'im after he hit the ground. Mr. Sam took a rest on a tree, an' when the rifle creaked the painter give a yowl an' jumped right toward us, an' come a crashin' through the vines 'ithin 20 feet of where we was a standin'. Jest as he hit the ground, pa give 'im both bar'ls, full in the face, an' sich a tearin' up of briers I never seen before, an' 'is growlin' was fright'nin' to hear. We stepped back of a cypress, out of 'is way, an' direckly he crawled up on a big log out of the briers. His head was all blood an' he acted like he was blinded. "Give it to 'im in the neck, son, an' stop 'is sufferin'," pa said, an' I took a good aim an' let 'im have it jest back of 'is head, an' that settled 'im. He rolled offen the log an' kicked a time er 2 an' died.

Mr. Sam had been a holdin' old Ring back ter keep 'im from gittin' tore up, an' when the painter was dead he turned 'im loose, an' such another proud dog I never seen. He'd smell of the varmint an' growl

an' look at us an' switch 'is tail like he was the king of dogs. The old painter was shore a bad lookin' critter an' I woulden fool yer. Mr. Sam's bullet had gone too high an' cut a hole in one ear, an' gashed 'im acrost the scalp. Pa had shot out both eyes an' riddled 'is breast, an' my shot tore 'is neck all up an' he was about as dead as they ginnally git, an' I was mighty glad of it, fer 'is tushes an' claws war terrible. Pa sez,

"Boys, we've got ter hustle, if we git that hide off, fer we've got ter be out of the swamp by night," an' we all 3 went ter work on it, an' had the hide off direckly. We made our way out quick's we could, but it was plum dark by the time we got clear of the swamp. Pa fired his gun an' hollered, an' in a minit we hearn Uncle Dick's gun go twice, an' direckly he had a big fire a goin' to guide us back ter camp.

We was shore the tired humans when we got there, an' hungry, gee whitiker! Well I reckon. Uncle Dick had the finest mess of steaks an' pertaters, an' biscuits, an' gravy cooked up I ever tasted, an' he had a chunk of the back straps with the kidneys on it, baked in the skillet, an' talk about yore eatin'! But we shore done some of it that night.

After supper we stretched out the painter hide, an' it was 3 times the length of pa's ramrod, which is jest 3 foot long, lackin' an inch. We laid around the fire an' made plots fer nex' day. Pa said there'd be a frost in the mornin' an' if we could kill 4 or 5 deer, we'd pull out fer home the day after. I didn't mind goin' home so bad now I'd killed me a deer, fer the sooner we got there the quicker I'd git my rifle. The last thing I hearn that night was 2 foxes a barkin' clost ter camp.

---

## A DAY OFF.

EMMA G. CURTIS.

There's a big covered wagon drawn up at  
the gate,  
There's crowding and hurrying, none must  
be late;  
It is seven already, there's no time to wait,  
The toilers will take a day off.  
It is hot in the hamlet and dull on the  
farm,  
The toilers are weary, of brain and of arm,  
They seek now the mountain's or forest's  
wild charm,  
Where care's heavy crown they will doff.

There's a big covered hamper stored some-  
where inside  
With loaves of white bread and with  
chickens brown fried,  
With pies where red cherries and raspber-  
ries hide,  
With pickles and jumble cakes, too.  
No fashion-cramped picnic is moving, I  
ween,  
A cluster of neighbors seek some quiet  
scene  
Where worries invade not, where Nature  
is queen,  
Where healing and rest they may woo.

They will camp where bright waters have  
murmuring sweep,  
Where shadows lie heavy, where light-  
daggers leap,  
Where children may frolic and wade ankle  
deep,  
And revel in pleasure's glad quest.  
The lunch will be spread under wide  
branching trees,  
The diners will bare fevered heads to the  
breeze;  
And tired out women will gossip at ease,  
And work-weary hands will find rest.

Then after the day and its glories are  
done,  
Well wearied, well rested, and happy each  
one,  
The wagon will homeward at setting of  
sun,  
Discharging its freight at the door.  
In the stillness of midnight the toilers will  
dream  
Of echoing bird song and soft flowing  
stream.  
Will wake with new courage at morning's  
first beam,  
And welcome life's burdens once more.

## FROM THE GAME FIELDS.

The man who quits when he gets enough, with plenty of game still in sight, is a real sportsman.

### TIGER.

Old Tiger has gone over the range; gone to meet Dell, who quit her saddle when the soap weed bloomed last year.

As Tiger has so often, in the past 10 years, crossed the trail before the readers of RECREATION, I believe you will be interested in this, his last great journey. Not that I would try to tell the many incidents in his eventful career. Their recital would fill RECREATION from cover to cover. Neither do I say "he is dead;" for he passed on so peacefully it hardly seemed like death, but just the going from one good hunting ground to a better one.

During the past few months we could see that his 12 years of active life, and the swift pace he had set during his hunting and trapping seasons, were telling on him. Twice within the past 2 months he received loud calls from beyond the big mountains; but each time we coaxed him back; and each time took a little better care of him. We gave him a good bed in the house, when he wished it, and the only password, day or night, was a whine at the door, which was always answered. When the nights were cold, or the fire burned low, we covered him with his old Navajo blanket. Few children have better care than old Tiger had in his last days, and as spring came he seemed quite his old self again; but early one beautiful May morning when the old cottonwoods down by the river were feeling proud over their first tiny leaves; when great bunches of cactus up Wildcat gulch were getting ready to put on pink; when the graceful quaking aspens, higher up the mountain were swelling little bits of green, we found him under the trees at home.

No indication of pain, or sign of struggle could be seen; just the good Lord, not the uncertain God of doubtful justice that theology teaches, but nature's real God of everlasting love, had blazed the trail for him to the land beyond the mortal thought. The dream that we call mortal life had changed for him into the reality that is eternal.

I sent word to my partner, one of Tiger's best friends, who had camped for weeks at a time with only Tige for company. He came, without waiting for his breakfast.

"We'll bury him," I said, "out by the old trapping grounds. Will you order a carriage? Get Tim Roan if you can, for he is a real Westerner."

At 9 o'clock my partner came, with Tim and his carriage. My business engagement with the St. Louis man for 8.30 was

broken. Over the telephone came word that the committee would meet at 9.30.

"Tell them I can't be there. We're going to bury Tiger," I said.

"But we have got the committee together from the ends of the earth, almost. Can't——"

"Tell them I shall not be there. They will have to wait," went back over the wire.

Partner also had important business on hand: a big mining deal.

"Can you spare the time?" I asked.

"They can do something else till I get back," he replied.

So we started. It is a long way to the old trapping grounds with a carriage, for civilization, that messenger of doubtful good, has made vast strides about Canon City in the past few years, and we had many fences to go around before reaching our destination. On a little bluff high above the danger line from floods we dug a grave. Pine boughs, laid like a camp bed, covered the bottom. Over them Dell's best blanket was spread, and to make it still softer, Tige's old Navajo; and with a copy of RECREATION containing a story of "Old Mose," a bunch of lilacs from the lawn where Tiger liked best to sleep, and a cutting of rose buds from the choicest bush, we laid him to rest, close by his old hunting grounds. A bunch of cattle, on the hillside above, stopped grazing and looked down in silent approval. Off to the North loomed the wonderful Beaver mountains, Tiger's first camping grounds; this side of them old Cooper, Felch creek and Lawrence canyon; he has hunted there; to the West the Tallahassee country, Burrows mountain, and the dear old Stirrup ranch; he knows them all. To the South lie Virden mountain, Copper gulch and Grape creek; he has been there, too, and in many other places far beyond; to the East, his old home, and an empty kennel.

We miss the whine in the early morning, and the trot of tired feet through the day. We miss the quiet doze of an evening, on his blanket in the corner, or curled up, as he liked best, on the big Navajo at the head of my bed. It would be selfish indeed to wish him back and I like to think of him as he is, in a country beautiful beyond description, chasing coyotes, but not to kill. I can see the spikes on his old hunting collar, but they are turned to gold, and his brindle coat is creamy white. He is getting ready for a big camping trip and I wonder if I shall ever meet him, away over that wonderful trail far above timber line. Who can tell?

N. H. Beecher,  
Canon City, Colo.

## THE PRESERVATION OF GAME.

STANLEY C. MORGAN.

[Extract from a paper read before the Boys' Literary Society of the Waukesha, Wis., High School. Master Morgan is but 15 years old. I wish all boys felt as he does on this subject.—EDITOR.]

There can scarcely be named a State or Territory that has not good game laws on its statute books; but laws that are not enforced are of no avail. Strict game laws must be enforced, or the remaining game will, like the buffalo and the Indian, soon disappear from our forests and our mountains.

Fishing and hunting furnish the best kinds of recreation and exhilarating exercise which benefit mind and body. If we would have future generations enjoy these sports and have these opportunities, we must protect the game. It is not wrong to take an animal's life for recreation. If it is right to kill animals for food, it can not be wrong to sacrifice them for a higher purpose, as health of body and mind.

The true sportsman is a student and lover of nature. He kills his game in the most humane way; no snares, traps or poison. He makes every effort to secure wounded beast or bird. He does not hunt in the breeding or nesting season, when young creatures would starve on account of the death of parents. He never takes more game than he can use, but always leaves some for the next man.

Game animals, game birds, song birds and fishes are the life of the landscape. What would the forests be without a deer, bear or moose? What would the prairies, fields and woodlands be without the game birds and song birds? What would the lakes, rivers and brooks be without a game fish?

It would be a most lamentable thing from a scientific point of view if future generations should have no opportunity for studying large and small mammals.

The preservation of our song birds depends largely on the protection of the game birds; for as soon as the goose, duck, prairie chicken, quail, etc., disappear, the robin, meadow lark, thrush, blue bird, etc., will become "game" and will soon follow. This is so in Italy, where real game birds have disappeared, and where the peasants kill nightingales and skylarks by the thousands as those birds migrate along the coast.

Sportsmen in general advocate the propagation of game birds by the State and federal governments, with a view to preserving them. We have national and State fish hatcheries; why not national and State game bird hatcheries? There is more reason for the artificial propagation of game than of fishes, because nature has in various ways provided for the protection of fishes more

liberally than she has for the protection of game.

It may soon be necessary for farmers, who have more at stake in the preservation of game than all others, to form county or township organizations, and charge every hunter who comes into their territory a fee for the privilege of hunting. Then there would be an inducement for the farmers to raise and protect game. This plan has been adopted in Germany, and game there is as plentiful as it was 400 years ago. No person has any right to take game which is the property of the people and make merchandise of it for his own profit. The selling of game will accomplish its complete extermination if not stopped, and it could be stopped within a few months if all the States would do their duty and enforce their laws. It is a well known fact that in all the more thickly settled States our game birds are decreasing each year; in some sections, as much as 50 per cent.

At this rate it will be only a short time before they will become extinct. This loss would be enormous in its effects. Not only to the sportsman and the interests he represents, but also to the farmer and those dependent on agricultural products. The number of insects which game birds destroy is almost incredible. These insects wage relentless war on crops and all kinds of vegetation.

The material value of our game is enormous and should be a strong factor in preserving it. Many people are annually attracted to this State by the good hunting and fishing. They leave many thousands of dollars here. Maine expends \$30,000 annually for fish and game protection and propagation. Her people receive over \$200,000 from the visitors who annually go there for fishing and hunting.

The real and effective protection of our game must be built on the sympathetic understanding that it was placed on earth by a bountiful Creator to endure, and not to be exterminated; to delight the eye and make this world a good and interesting place for man to live in, as well as to furnish him with a portion of his subsistence and a means for healthful recreation.

## WAS ACQUAINTED WITH MOSE.

I have read H. N. Beecher's "Life Story of a Grizzly," in December, 1902, RECREATION and find the main points true, for I hunted in Colorado from 1882 to 1896 and I think I traveled farther after old Mose than any man in that part of the Rockies. Beecher credits me with killing old Mose's father and brother, which I did.

I began hunting Mose in '86. The first night I stopped at Hodges' ranch on Cottonwood, 12 miles from where I killed the King of the Rockies. I told Mr. Hodges

I was after Mose and he said the old fellow was up there, but advised me to go back. I did not know much of Mose at that time, but wanted to get a look at him, so I moved over to Waugh's, now known as Stirrup ranch, and early the next morning I started for Poncha mountain. I had not gone far when I sighted the plain trail of old Mose. He seemed to be walking leisurely along the gulch leading to the top of the mountain. I followed cautiously for half a mile and suddenly came within 100 paces of him. He saw me at the same time I saw him. There was a cedar bush between us, and I stepped to one side to get a good shot, but I stepped on ice and fell. Mose was standing on his hind feet, looking at me over his shoulder, and before I could get up he had got behind some spruce shrubs, out of sight of me. That was the only time I ever had the pleasure of looking at this monster of the Rockies. I had no traps at that time, but I hunted him 15 days, saw signs of him every day, but never got sight of him again.

Then I went over on Poncha park, killed a large buck antelope, and started for Canon City, but stopped on lower Cottonwood and got a big cinnamon bear that had just killed a 3 year old steer for Joe Hall.

Every week brought new reports of Mose's scaring prospectors, killing cattle and raising Cain generally; so, for 5 years, each season when his hide was supposed to be in good shape, I, among others, loaded up grub and bear traps and went after him. Each year I found one or 2 carcasses of animals he had killed. He would lie around and eat, only going for water; and he would never return to the same spot after he had finished devouring his prey.

In the fall of '95 Whort and I camped above Stirrup ranch. One morning Whort went up the gulch about a quarter of a mile. All at once I heard what sounded like the battle of Bull Run, and Whort came down to camp looking as if he had been in the run part of the fight. After breakfast he showed me where he had stood and shot at an old bear and 2 cubs. I went over and found one fine fat cub he had shot through the head. Next morning we went up the mountain about a mile. Suddenly 2 prospectors dashed into view, running down the mountain at the rate of about 20 miles an hour.

"Hi there!" shouted I, "what are you running for?"

"Because we can't fly!" roared one.

They had seen Mose, and had given him a chance to run; but he wouldn't.

One summer Joe Hall went up the mountain for wild raspberries. He had picked a big bucketful besides eating many more, when Mose happened along and took after him. Joe ran around a big log, with Mose

after him. Joe gave up his berries, bucket and all, climbed a tree and yelled so loud that for the first time on record Mose ran, after the fight had commenced. It took 2 days for the color to come back into Joe's face, and it is said he never wore the same suit of clothes again.

The bear I killed was the one that killed Jake Radcliff, and its weight was 1,213 pounds. Mose had larger tracks than the supposed Mose senior, and I consider him the shrewdest bear ever known in these parts.

I like your stand on the game question. I have killed game of all kinds, but never wasted a pound of meat or killed an animal for the skin.

J. J. Pike, Slagle, Mo.

#### MY BIGGEST KILLING.

In the fall of '69 my wife and I and her brother and his wife moved from the Willamette to Eastern Oregon and settled in a small village through which ran a mountain stream emptying a few miles below into the John Day, 90 miles above its mouth.

The hostile Snake Indians had just been driven out, while as yet there was but a sprinkle of white settlers. It was a beautiful country. Bench lands on which were scattering junipers extended back from the rivers 6 or 8 miles. Then came a spur of the Blue mountains, 15 miles across, covered with an open forest of pine, with fir and tamarack in the gulches and on the hillsides. Beyond this a plain, marked with an occasional canyon, rolled North 60 miles to the Columbia. There was bunch grass everywhere, uncropped save by wild animals or Indian ponies.

This plain is now netted with barbed wire fence and its surface is scarred into unsightliness by the gang plow. In the mountains and on the benches the bunch grass that was cured like hay by the cloudless sun of summer, has been almost stamped out of existence by bands of sheep, horses and cattle. Stock men have fought, bled and died over the division of the remaining mountain range. The great herds of deer that used to come from the mountains to winter in the John Day country have vanished like the bunch grass.

During the winter following our entrance into this country, our little party became meat hungry. Whitetail and mule deer were numerous. With a small bore, rusty, muzzle loading rifle I had climbed the foot hills, for the whitetail and had crept up behind rocks and junipers for the mule deer, but without success.

One morning as I shouldered my rifle my sister-in-law, who was an invalid, banteringly remarked that she would carry in all the game I killed that day. A short dis-

tance from the house I came on a whitetail standing on a steep hillside, some 30 yards away. At the crack of the gun the deer came rolling over almost to where I stood. Regaining its feet, it seemed bewildered a few moments. Then and there I was struck with the buck ague. I shook like a person with the every-other-day chills. I spilled half the powder trying to pour it into the gun. I could not find any patching, so I tore out a piece of my shirt. I drove the bullet home and threw down the ramrod. My hand trembled so I could scarcely cap the tube. In the meantime the animal came to and bounded off. I went home again without meat.

There were 2 hunters camped 15 miles below, at the mouth of a small creek that entered the John Day. To them I went, riding one horse and leading a pack. The next morning after my arrival, in company with one of the hunters and carrying a heavy muzzle loader, borrowed from his partner, I went out after meat. The reservation Indians were making a drive toward us; but we did not then know what made game so plentiful. At short distances we could see bands of deer on the rimrocks that jutted out from the hill sides. When any came within range our muzzle loaders would speak.

My companion was a dead shot and a brutal man. A cruel gleam would light his eye (he had but one) when he saw his victim fall, and he would spring upon and stamp the helpless thing if it struggled while he put the knife to its throat. No matter how many he killed; I was not responsible for his actions, and besides I am not writing his story.

I brought down 3 deer, and the next morning loaded my pack for home. Don't put me down as a game hog, for we dried the 6 hams for summer use and were not long in getting away with the corresponding sides and shoulders.

E. O'Flyng, Salem, Oregon,

#### MONTANA ABOLISHES SPRING SHOOTING

I enclose newspaper clipping showing what has been accomplished by our late Legislature for the protection of our game. You will be pleased to learn that turtle doves are now protected at all times. There are a few small bands of antelope near here which have grown less wild since they were put on the protected list. I can see 15 any day within a mile or 2 of the house, and last fall they watered in the meadow within sight of the house, every day or 2. While the new game law, which closes the season for deer December 1, instead of January 1, as heretofore, will be of great benefit to the deer by shortening the season and protecting them when the snow is deep in some localities, yet in the

Little Snowy mountains, where I hunt, it will not be an unmixed blessing, as we often have no tracking snow until December, so that hunting will have to be done on bare ground, which will allow many wounded deer to get away.

I have been here 20 years, and although in the sheep business myself, I speak without prejudice when I say that, while the mountains are heavily pastured by sheep every summer, I see little diminution in the number of deer to be found every fall. Of course existing conditions must be taken into consideration. It was always the custom of the deer, which, by the way, are of the whitetail and mule species, to go into the higher ranges in the summer, where sheep are unable to range, and to come down when the snow gets deep; few remaining to have their fawns on the winter range. As our snowfall is generally light, deer seem able to winter in fair condition in spite of the sheep. I have only twice in 20 years seen over a foot of snow in the foothills.

The abolition of the spring shooting of ducks and geese, although few nest here, was advocated by all true sportsmen. I wish all States would follow Montana's example in that respect.

Joseph L. Asbridge, Highfield, Mont.

The clipping to which Mr. Asbridge refers is as follows:

Under the new game laws of the State turtle doves are protected at all times. One may kill one mountain sheep a season. The open season on elk is the same as heretofore and the new law allows the killing of 2 bull elk during that season.

The open season on deer and Rocky mountain goat is established in the new bill as September 1 to December 1. The season on mountain sheep is the same. The new act permits the killing of 3 deer and one goat; but it prohibits the hunting or chasing of any big game with dogs.

The open season for grouse, prairie chickens, fool hens, sage hens and pheasants begins August 15 and ends December 1.

The bill abolishes the spring shooting of aquatic fowl and makes the open season for geese, ducks, brant and swans September 1 to January 1.

The new law fixes the non-resident license at \$25 for big game and \$15 for small game. It makes provisions also in regard to the exporting of protected game or any part thereof from the State.

The new act further provides that every person who is engaged in the business of guiding must procure a guide's license.

Further, the act provides that all taxidermists must secure license.

I am glad to know that your Legislature has passed so good a game law, and that antelope and deer still have so good a show for a permanent existence. As you doubtless know, I have been, for 5 years past, working diligently to secure the enactment of laws providing long close seasons on antelope in the various Western States, and it is indeed gratifying to know that so many of these States have complied with the wishes of all Nature lovers in



stopping the killing of these beautiful animals. I am sure this report will be hailed with delight by thousands of true sportsmen.—EDITOR.

---

TEPEE LIFE.

One of the results of the tendency of this generation to enjoy life in the woods is the establishment of an Indian village for white people at Desbarats, Ontario. Every residence in the village will be a tepee or an Indian lodge. The tepees will be large, so that with a small fire in the middle there would be ample room to stretch out with feet to the fire and head to the outside skin. The site chosen is where the Ojibway play of "Hiawatha" is given.

To facilitate matters for busy men all necessary supplies will be furnished in a convenient way. Canoe trips will be organized, fishing parties conducted, and in every way difficulties to the uninitiated will be reduced to a minimum. The art of helping themselves will be taught the luxurious, gently and by degrees, so they may not be discouraged at the outset. The situation is one where the luxuries of life, which are indispensable for a time to those who have been their slaves, will be within reach. In this way the monotony of the physical exercises taught by health culturists is done away with. The weaker disciples of the simple life will chop a little, paddle a little, walk a little; and their tasks will daily be increased in careful measure, so that the utmost benefit may follow.

The country in the vicinity abounds in large and small lakes and game and fish. The season will gradually be extended, beginning in May for the trout fishing and ending November 15th, so as to take in the big game hunting season. For this year it will begin July 1st and last until November 15th.

It is a laudable ambition to harden oneself to endure the sun as well as the cold. At Desbarats a sunbath lasting 3 months can be taken, as it is rare for the sun to be too hot to keep people from walking, boating, canoeing, etc. Much may be gained by staying out in the sun 14 hours a day in the North.

---

NOVA SCOTIA SWINE.

Capt. Mitchell Smith returned to Clarks Harbour, N. S., last week from a shooting excursion to Lockport in his steamer Cygnet. He took there a party of 4 good marksmen, besides himself, each with a small skiff of his own. All enjoyed a few days of prime sport in shooting ducks off Western Head. The total bag for 5 days was 515, mostly coots. The 3 leading scores for a single day were: Howard Smith, 46; Mitchell Smith, 43, Walter Smith, 42.—Yarmouth Telegram.

I wrote the persons named above, asking if their score was correctly reported. The following reply was received:

As regards my killing 46 ducks in one day, you were correctly informed. That was not an extraordinary score, for I have killed a greater number in one day several times, the largest number being 82. The ducks killed include coots, eider ducks, old squaws, loons, sea pigeons, shellducks, blue-bills, black ducks, brant, etc. I have averaged 2,000 a year for the last 15 years; the best for one year being 2,200. We shoot from boats as the birds pass in the fall and spring, going from and to their breeding ground on the Labrador coast. If you wish to know more about the sport I will be pleased to answer any questions.

Howard Smith, Hawk Point, N. S.

I know enough already to brand you as a despicable, contemptible butcher, and I am surprised that decent men anywhere should allow you to live among them and carry on such slaughter as this, year after year. If ever a man deserved to be dressed in tar and feathers and whipped out of the town you do. I trust your neighbors will soon realize their duty toward you and that they will perform it. You and the other Smiths are numbered 878, 879 and 880 in the game hog pen.—EDITOR.

---

ADMITS HIS GUILT.

We have a man here who exhibits 107 quails and 5 rabbits as the result of one day's shooting. Another day he killed 47 ruffed grouse. I wish you would give him a shaking up in RECREATION. It would do him lots of good. His name is Wm. McDonald, No. 10 S. New street, Staunton, Va. He shoots a Winchester pump gun and men who hunt with him say he never kills less than 3 to 6 birds out of a covey, on a rise. If that isn't butchery what do you call it? Please give it to him strong.

Subscriber, Taunton, Va.

I wrote McDonald as follows:

I am informed that you recently killed 47 grouse in one day, and 107 quails in another day. Will you kindly tell me if this report is true?

Here is his answer:

Your letter received. J. L. Bumgardner and I bagged 48 grouse in one day and I killed 95 quails in one day.

Wm. McDonald, Staunton, Va.

The fact that you unblushingly admit your slaughter proves that you are entirely ignorant of the principles of decent sport. You should read a few copies of RECREATION and learn that real sportsmen always

quit when they get enough, no matter how much game may still be within reach. Your number in the game hog pen is 881 and Bumgardner's is 882.—EDITOR.

#### OUR SOUTHMOST CORNER.

November 18th we left Miami in my 20-foot smack for a cruise among the Florida Keys. Were out 6 weeks. We shot plenty of ducks, plover and other birds, caught turtles and fish, saw many white herons and great flocks of white ibis.

This vicinity is the haunt of the American crocodile; it is the only place in the United States where he is found. I have seen several large ones here. One, the largest in existence, as far as known, was captured alive by "Alligator Joe" last summer, and is now at his place on Little river. It is 15 feet 6 inches in length.

The chief difference between the 'gator and the crocodile is the former has a broad nose, while the latter has a sharp or pointed one, with a tusk on either side of the lower jaw, extending straight up. The crocodile also is of a greenish hue, while the alligator is black or brown.

Miami is the Southernmost railroad point in the United States, and within 5 miles of the famous Everglades. The glades, as it is here known, is not, as commonly supposed, a morass, so thick with tropical growth as to be almost impenetrable. On the contrary, it is a vast territory covered with saw grass, growing in clear, flowing water, 1 to 2 feet deep. Here and there are small islands, on which the deer feed and the Seminole Indians find a home.

Any reader of RECREATION wishing a pleasant winter vacation can not do better than start for Miami.

Walter C. Fogg, Miami, Fla.

#### CAMPING.

The pleasure obtainable from a sojourn under canvas in the woods depends on the outfit carried, the location selected and the adaptability of the campers. Under proper conditions it is the most enjoyable and health-giving of pastimes.

The selection of the outfit depends, of course, on the nature and duration of the proposed trip. Plenty of clothing is essential. Do not omit a selection of simple medicines for common ailments, nor go off without soap, towels and tooth brush. A waterproof suit will add greatly to your comfort. Take with you an ax, a lantern and oil, matches, a few nails, compass, fishing tackle, a rifle or shot gun with plenty of ammunition, a hunting knife, coffeepot, tin pail, wire broiler, metal plates and cups, knives, forks and spoons. With those and

your blankets or sleeping bags you have all that is really necessary.

The tent should be large enough to hold outfit, provisions and your party without crowding. The quantity of food to be carried depends on the game and fish resources of the region you visit. I have found it wise to take a liberal supply and rely as little as possible on hunter's and angler's luck.

P. Noycar, Quebec, Can.

#### CRITICISES CONDITIONS IN MAINE.

I am an interested reader of your most excellent magazine, and heartily endorse the principles on which it is based. After reading the article on moose snaring, in January RECREATION, it seems to me one can find violations of the game laws in his own neighborhood; perhaps not on so large a scale, but wherever there is game, some will always be illegally taken, regardless of the law. Last fall I spent a few weeks in the vicinity of Moosehead lake. The residents never went hungry for deer meat. I saw one man in the woods with his pack basket full of it; yet, Mr. Carleton, of the Maine Fish and Game Commission, rules that non-resident sportsmen take home game in such quantities as to make it necessary to assess them; the proceeds to be devoted to watching the same visiting sportsman, who pays his guide \$2 to \$4 a day, feeds him, and in all probability buys supplies through him. The natives live in peace and plenty. If all brother sportsmen would use their influence in their own vicinity for the propagation and the preservation of all game, the result would be surprising.

Frank L. Palmer, Beverly, Mass.

#### NEW GAME CARRIER.

723,179.—Game Carrier. Milton C. Peters, Omaha, Neb. Filed May 5, 1902. Serial No. 105,971. (No model.)

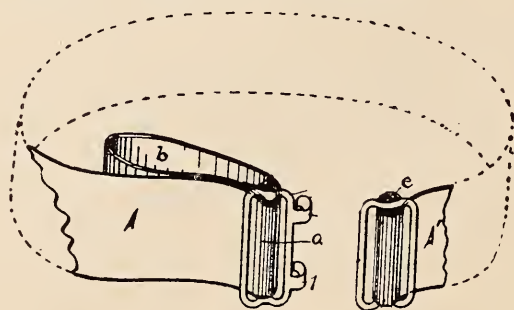

Claim.—A game carrier comprising a strand, a buckle arranged at each end of said strand, each of the extremities of said strand being curved to form an attaching loop permanently connected to the buckle thereat, said strand being coiled within the buckles and around said attaching loops when the carrier is adapted for use as a belt, said buckles having a slidable ad-

justment on said strand for enlarging the coils of the latter to form carrying loops, and a hook formed on one of said buckles and adapted to engage the other buckle for sustaining the carrier in applied position when used as a belt.

#### NOT A QUESTION OF GUNS.

I am heartily in accord with the sentiments expressed by Paul Mouser on page 203 of *March RECREATION*, only the gentlemen should have left the \$8 and the \$100 gun out of the question, because when the poor farmer's boy goes out with the \$2 ferret he leaves the gun home. He puts the ferret in the hole, and a meal bag over the entrance. The rabbit, terrified, bounds for the open and a chance for life, runs into the bag, is yanked out, and, squealing pitifully, is clubbed to death without a single chance for its life.

Is it not too bad that the poor farmer's boy who does this is termed a bristleback? Let us do away with the unfaithful setter because a hog, using a dog, kills more than his share.

Getting quails with a setter is as bad as murdering rabbits, Mr. Mouser says, and my experience sustains his argument. The dog points. Then all one has to do is to walk out in front of the dog and kill the quail when it gets up. Therefore, as an amendment to Mr. Mouser's well advanced theory, I suggest leaving both the \$8 and the \$100 gun at home.

Harvey J. Flint, Providence, R. I.

#### CAN NOT DENY THE CHARGE.

Snipe shooting is in full swing on Lulu island and the Delta, and sportsmen report varying success. Last year O. M. Sergeant Kennedy, of the Sixth Regiment, laid low no less than 337 of these birds, and this year 175 golden plover have fallen to his gun. A curious feature of the Provincial game laws is that no close season is declared for snipe.—Vancouver (B. C.) paper.

Though Sergeant Kennedy failed to reply to my inquiry regarding the truth of the foregoing report, I received the following:

Your letter to Fred Kennedy was read aloud in my place of business to-day. Kennedy said he would see you in —, before he would give you particulars. He admitted, however, that he had killed, in 1901, 687 snipe and plover.

E. Galloway, Vancouver, B. C.

As I have said before, a good way not to be called a game hog is not to be one. Mr. Kennedy's refusal to answer my inquiry direct can only be taken as evidence of his guilt, and he therefore justly deserves the contempt and reprobation of all decent sportsmen for having killed, as Mr. Galloway states, 687 snipe and plover in one season. Mr. Kennedy's number in the game hog pen is 883.—EDITOR.

#### MAKES WAR ON SPARROWS.

I have one strong ally in my relentless war on the English sparrow, although our motives differ. I refer to the shrike. Wherever I live, there is war on the sparrow. Wherever the shrike lives there is also war on the sparrow. He eats them, I do not; that is the difference between us, but the effect on the sparrow is about the same. I buy guns with great willingness, I spread out poison and I continually say hard words. If I find a nest I destroy it; yet I do not see that the pests decrease in number. I wish a stronger voice than mine would call on the Legislatures of the different States and see if a general war of extermination can not be carried on. English sparrows have driven out the robins and orioles that once nested in our oaks about the house; and now that dream of a song, the song of the early bluebird, is never heard near a town. Even the obstreperous jays leave in disgust. I do not blame them. By the way, if you live where the sparrow does not, put out little nest boxes for the bluebirds.

Maude Meredith, New York City.

#### PUMP GUN PROHIBITED.

The new ordinance prohibiting the use of the pump gun in Marin county, this State, is a step in the right direction. In most States the use of a gun larger than 10 bore is prohibited. Is not this because the larger bores are considered too destructive? A 12 gauge repeating shot gun in the hands of a good shot must be far more destructive than a single or double 10 bore. I call to mind a letter from a man praising his repeater. He said a flock of 10 ducks flew over his blind and he got them all; not one escaped. Some say it is not the gun that makes the hog. That may be true; but if the use of the pump gun is allowed, the hog will certainly use it. Four things must be done before we can have perfect game protection. These are: Prohibit the sale of game; limit the bag; prohibit the use of guns which are too destructive; enforce the game laws, whatever they are, and if not good, have them changed.

F. T. Johnson, Los Angeles, Cal.

#### A SAMPLE OF KENTUCKY PORK.

Emery Tapscott went to Marshall county last Tuesday and returned Friday afternoon with over 300 quails, as the result of Thursday afternoon's and Friday morning's hunt.—Paducah, Ky., Democrat.

I asked him about it and received this reply:

I did kill 300 birds from Thursday morning until Friday at 3 o'clock p. m. The next morning I killed 8 geese over my trained decoy in less than 2 hours.

E. E. Tapscott, Paducah, Ky.

This proves that you are another

of the despicable type of swine that insist on killing everything they can find, and leaving nothing for decent men. It is for such as you that game laws are needed, limiting the number of birds which any man or beast may kill in a day, and I trust Kentucky may soon pass such a law. You are branded number 884 in the game hog pen.—EDITOR.

---

GAME NOTES.

I carry RECREATION with me everywhere and enjoy it greatly. Deer are numerous here but are fast becoming extinct. One family in the vicinity of Hayden lake has about 15 hounds and they run deer at all seasons. A few days ago I heard the bay of hounds 10 miles from any habitation. I saw a large white tail buck coming down the middle of the stream. His left horn was broken off and he was shot through the jaws. As I had my 30-30 Winchester, I shot him to keep him from being torn to pieces by the hounds close in pursuit. My 2 partners came along then and we carried him into camp. The game season was closed but I think I was justified.

J. B. Hopkins, Rathdrum, Idaho.

The proprietors of a leading butcher shop, located on Brady street, were felicitating themselves Thursday evening on the fine display of game they were making to attract holiday customers. Yesterday morning the display did not make them so happy. It chanced that among the quails, ducks and other birds were 6 prairie chickens. The latter had been ordered for a certain customer and had arrived Thursday afternoon. They were to be delivered yesterday, and in the meantime they were hung up to make as fine a showing as possible. However, the law forbids a dealer to have prairie chickens in his possession after December 1. George Bethel, deputy game warden, saw those birds and confiscated them, at the same time arresting one of the proprietors of the shop. Proceedings were instituted before Police Magistrate Finger, who imposed a fine of \$10 for each of the chickens, or \$60 in all. This amount was paid.—Exchange.

I am trapping wolves and coyotes these days, and am having fair success. Some letters in RECREATION amuse me; for instance, one from Mr. Heist, of Alberta. He claims to kill ducks at 95 yards and never shoots at anything under 60 yards. Also a letter from a man in New York, who looked into a stubble field, saw the stubble move, fired, and killed 3 quails. Then he stalked another quail that was sitting on the fence, and wrote to RECREATION condemning the use of dogs. I have an old setter that has forgotten more about sportsmanship than that man ever knew.

I. Northey, Alberta, Can.

I am a reader of RECREATION and enjoy it much. I am a great lover of the rod and gun; also of fair play to the game. One thing that is sadly overlooked is the de-

struction of camps. How many times has a man traveled all day through the woods, depending on a certain camp to pass a comfortable night in, only to find some fool has been there ahead of him and from sheer cussedness has broken the windows and the stove or torn the door off the hinges? This sort of man needs the roast, but 9 times out of 10 he hasn't brains enough to take it seriously.

Harry D. Baird, Woodstock, N. B.

The ideal place to hunt caribou is Newfoundland. Although the license fee is \$100, and one is permitted to shoot but 3 stag caribou, it is worth the money. I was there 6 days and during that time saw over 200 caribou. I had no trouble in getting 3; all having fine heads. Good guides can be had reasonable. Caribou are numerous and the high license probably protects them. I was told by an officer that there would be a reduction of the license fee next year.

Wm. D. Brinnier, Kingston, N. Y.

This country abounds with chickens, quails, jack rabbits, cottontails, wolves, and in season ducks. There are a great many lakes here containing black bass, croppies, pike, pickerel, sun bass, silver bass, and perch. During the winter there is a great deal of fishing through the ice. Only one hook is allowed, with live minnows, and no bass to be kept.

M. E. D., Onock, Minn.

---

THE TRUANT.

(Reading the Mail.)

EDWIN L. SABIN.

Smith says that same darned copper crowd  
Is kicking up a rumpus,  
And that old Colonel Black's allowed  
This time he'll surely bump us!  
I'll wire Black, thus: "Off Middle Rocks  
(He'll know where! Won't he flounder!)"

While you were fooling 'round with stocks  
I caught a 7-pounder!"

Nell says Doc Thorne has asked about  
My pesky indigestion;  
He's studied up a cure without,  
He thinks, the slightest question.  
Thanks, Doc and daughter; but I've for  
A diet that just caters;  
A half a dozen fish, well browned,  
Fried onions, pork and 'taters!

Wife writes her music-tea was fine,  
And voted swell and pleasant;  
The Skorski solo was divine,  
And Lord de Whott was present.  
Why, wife, I've got a catbird here  
That knocks that Skorski silly!  
And as for Lord de Whott, my dear,  
Give me old Injun Billy!

## FISH AND FISHING.

### ALMANAC FOR SALT WATER FISHERMEN.

The following will be found accurate and valuable for the vicinity of New York City:

Kingfish—Barb, Sea-Mink, Whiting. June to September. Haunts: The surf and deep channels of strong tide streams. Baits: Blood worms, shedder crabs and beach crustaceans. Time and tide: Flood, early morning.

Plaice—Fluke, Turbot, Flounder. May 15 to November 30. Haunts: The surf, mouth of tidal streams. Baits: Shedder crabs, killi-fish, sand laut. Time and tide: Ebb, daytime exclusively.

Spanish mackerel—Haunts: The open sea, July to September. Baits: Menhaden, trolling—metal and cedar squids.

Striped Bass—Rock Fish, Green Head. April to November. Haunts: The surf, bays, estuaries and tidal streams. Baits: Blood worms, shedder crabs, Calico crabs, small eels, menhaden. Time and tide. Night, half flood to flood, to half ebb.

The Drums, Red and Black. June to November. Haunts: The surf and mouths of large bays. Bait: Skinner crab. Time and tide: Day, flood.

Blackfish—Tautog, April to November. Haunts: Surf, vicinity of piling and old wrecks in bays. Baits: Sand worm, blood worm, shedder crabs, clams. Time and tide: Daytime, flood.

Lafayette—Spot, Goody, Cape May Goody. August to October. Haunts: Channels of tidal streams. Baits: Shedder crabs, sand worms, clams. Time and Tide: Day and night flood.

Croker—July to October. Haunts: Deep channels of bays. Baits: Shedder crabs, mussels. Time and tide: Day, flood.

Snapper—Young of Blue Fish. August to November. Haunts: Rivers and all tide ways. Baits: Sparring and menhaden; trolling pearl squid. Time and tide: Day, all tides.

Sheepshead—June to October. Haunts: Surf and bays, vicinity of old wrecks. Baits: Clams, mussels, shedder crabs. Time and tide: Day, flood only.

New England Whiting—Winter Weak-fish, Frost-fish. November to May. Haunts: The surf. Baits: Sand laut, spearing. Time and tide: Night, flood.

Hake—Ling. October to June. Haunts: Open sea surf, large bays. Baits: Clams, mussels, fish. Time and tide: Day and night, flood.

Weak-fish—Squeteague, Squit. June to October. Haunts: Surf, all tideways. Baits: Shedder crabs, surf mullet, menhaden, ledge mussels, sand laut, shrimp. Time and tide: Day and night, flood preferred.

Blue Fish—Horse Hackerel. June to November 1st. Haunts: Surf, open sea and large bays. Baits: Menhaden, surf mullet and trolling squid. Time and tide: Daytime; not affected by tides.

### JOSH BILLINGS ON TROUT FISHING.

(From an old newspaper.)

Brook trout are a spekled institooshun.

They are more delikate, more nervous, and more intrinsik than ennything that wears fins or feathers. They are az sudden and gamy az a perkushion match, and a trout that weighs one ounce will bight hiz whole weight, and will bight az fearless and sartin az a rattlesnaik.

A brook trout that weighs 5 ounces will pull out ov the water more unwilling than a sucker that weighs 2 pound an 3 quarters.

I don't believe a square orthodox brook trout ever weighs more than 2 pound.

All trout that beat this weight are mon-

grels, crosst on sum other breed ov a similar natur. Scientifick men will teil yu different from this, but they aint to blame for what they don't kno.

Take a trout out of a mountain brook in Nu Hampshire that weighs one ounce, and feed him 16 years and yer kant make him weigh 4 pound and a haff.

A man who don't hanker hard for the sport kant larn to ketch the darling kritters, unless it iz in sum far off water, where it aint safe to stick yure fingers into the brook for fear ov gettin bit bi a trout.

Trout ketchin in the old and well fisht streams iz a natral takt, and a man haz got to be born the right time ov the moon or he kan never do it hansome.

Expensive riggin' won't ketch trout enny more certain than a hi priced phiddle will play well with the wrong man hold of the bow.

Fly fishin' is konsidered the most poetick and at sum sezons ov the year iz the most fatal, but the poorist fishermen i have ever seen could talk fly fishin' the most numerously.

It iz az difficult to pik out a ded sure day to ketch trout az it iz to name a good piknik day 24 hours in advance.

I hav seen trout bight az krazy as a musketo to-day, and to-morrow (the same kind ov a day exacly) bight just out ov compliment to a good fisherman.

The wind haz more to do with the humor ov a trout than enny other outside thing.

I would az soon think ov goin' to meetin' barefoot az to go trout fishin' with a strong East wind.

A bright day, with a clewer West wind, with plenty of sunshine and shaddo, iz the day i bet on.

The bait on yure hook, and the way it iz put on, iz of more consequentz than the German silver on yure fishpole.

The smaller the hook the better for all sized trout.

The quick fishermen are the best ones. It iz hard work to outstay a trout or argy him out of his opinyun.

When a trout haz the wonts he haz 'em bad, and when he haz the wills yu kant stop him.

The fust drop ov the bate into the hole iz the important one. A trout iz the most natral ov all fishes, and the more natral the bate strikes the riff, or the pool, the better understanding at once between yu and the fish.

It allmost spiles a man to ketch one ov these 5 pound lake trout. He kant talk well about ennything else afterward less than a whale, and he ekspekts ov course that

hiz nabors will nominate him next fall for the Assembly.

A man who haz caught one ov these big fish iz generally prouder ov it than he iz ov his grandfather, and if he ain't a pretty well balanced man he will git to talkin' about it in sum evenin' meetin'.

Broiled trout are good, but fride in pork juice they are better.

All fish to be the best should be cooked with animile life enuff in them to do their own floppin' on the gridiron.

Ninety-nine big trout out ov every 100 are kaught bi mistake, and are az often kaught bi barefooted boys with a hum-made fish line and a willow pole.

I hav fisht for brook trout for 40 years, and never kaught but one that weighed over a pound, and dropt mi pole and line bi the side of the hole where i ketched him and run home, 3½ miles, with that trout in both hands, more exalted than a newly elekted constable.

I never hav fisht for lake trout; i don't want to spile mi simplicity for brook trout in the hills and meadows.

What I kno about trout and trout fishin' may all be wrong, but i hav'n't got it out ov books, but pikt it up az i did mi fust pair ov shuze, by workin' for it.

The only theory i hav in the matter iz allwuss to fill mi basket when i go out, and hav often done it in the last hour's fishin', when it did seem az though trout waz az skarse az prayers among the nuzebos.

I kaught 1492 brook trout last summer in the White Mountains, and if I hadn't been as modest as a book agent, i should have been spilte bi the menny compliments i received for mi good luk.

Next to ketchin' a brook trout that weighs a haff pound cums the bliss ov bringin' him in to yure hotel.

#### LECTURES ON FISH AND GAME PROTECTION.

One of the required courses in the New York College of Forestry of Cornell University is a course in fish culture and fish and game protection. During the spring term the juniors and seniors of that college are located at Axton, in the heart of the Adirondacks, where the college owns 30,000 acres of forest. There the students observe and engage in practical forestry operations, observe and study logging, lumbering and milling, and become familiar with the details of forestry operations and management.

In the belief that forestry operations should not be carried on in a way detrimental to the useful animals inhabiting the forest or to the lakes and streams and their inhabitants, Dr. Fernow, the director, has provided a course of lectures on these subjects. The course consists, first, of a

series of lectures and demonstrations on fish culture in which are considered all of the important fresh water fishes, particularly those found in the lakes and streams of our forested regions; second, lectures on stream and lake pollution and the necessity for their protection; third, lectures on American game mammals, birds, and fishes, the relation of insectivorous birds and other animals to the forest and to agriculture, the principles of game protection, and a discussion of game laws and regulations, including the Lacey law and the work of the League of American Sportsmen.

In addition to the formal course of 25 lectures, the students are taken on daily excursions to streams, lakes and mountains for observation work. The effects on the streams of logging and lumbering operations are observed, and the fishes, mammals, birds, plants and other animals of the region are studied, thus giving the students training and interest in proper methods of nature study.

This course is given on alternate years by Dr. B. W. Evermann, who has just been promoted to the position of Assistant in Charge, Division of Scientific Inquiry, U. S. Fish Commission, and the course is unique in American college instruction.

The importance of instruction along these lines is only coming to be appreciated and it is a work which other colleges would do well to take up. Courses in zoology in our colleges deal too largely with questions which have no bearing on animals as living organisms, many of them intimately associated with our physical and commercial as well as intellectual well being. The natural history spirit needs to be fostered; students, from the grades to the universities, need to know more of Nature, to have a greater love for her children, and an appreciation of their place in Nature's economy and our daily life.

The course this year was given during the first 3 weeks of May to a class of 25 students and professors and proved successful in every way.

#### PROBABLY NETTED THEM.

Your letter to hand asking about catch of fish reported to you. The report is true. We made the catch in Deer Lodge county, 20 miles from Anaconda. There were 4 of us. My partner and I, fishing one hour and 10 minutes, filled our baskets and dug holes in the snow and piled them full. We used no bait but flies, 2 on each line, and about half the time pulled out 2 fish. When it was time to go Mr. Conrad took off his waterproof coat and piled the fish into it. When we reached camp we had 355 trout about 8 inches long each. Our partners returned to camp with a few fish;

much larger ones than we had but not so many. About 2 o'clock we all 4 went out again and fished a while. Soon we had as many as we thought our friends and ourselves could eat. All told, we had 900 as nice trout as any person could wish. You may not believe this. Many of our friends did not, when we came home so soon; but when we opened the boxes and showed the telltale hook mark in the mouth of every fish they could not help believing.

James H. Blackburn, Charles Beaudette, Ernest Beaudette, Eugene Conrad.

Mr. Editor:

I don't know if you are going to publish this or not but if you are in justice to me Please fix up a little as i am a verrie poor schollar and my friends may see it and the way i have of telling it may not look verrie well in print but is true in every respect, as i could prove by dozens of people here now i hope that this is filling the bill as you wished it. Yours respectfully,

James H. Blackburn, Anaconda, Mont.

P. O. Box 336.

P. S.—Annie Inquiries will be cheerfully answered by me, cumming from annie person intrested.

Yours,

J. H. B.

Blackbrough's report is certainly unique. He says he and Conrad took 355 trout in one hour and 10 minutes, and that the entire catch of the herd was 900 trout. This record of 355 trout in one hour and 10 minutes sounds very fishy. It means about one trout every 25 seconds for each man. Does anybody believe that story? It sounds as if these trout had been netted, after all. Men who would make such ravenous hogs of themselves as this crowd did, would net trout; then sit around the camp fire and mutilate the mouths of the fish if necessary, to try to convince their friends that they had taken the fish with hook and line. However they may have been taken, the performance is disgraceful and disgusting in the extreme, and the brutes who did the work should be tarred and feathered and run out of town. Their brands in the fish hog pen are as follows: Blackburn, number 885; Charles Beaudette, 886; Ernest Beaudette, 887; Conrad, 888.—EDITOR.

#### A SURPRISING ADMISSION.

For several years J. C. Bradley and M. S. McCreary, with their families and mine, all of Erie, Pa., have camped at the Elms, Chautauqua lake. This is a delightful place to camp. We have good fishing, pure spring water, bathing and clean shores. We catch principally black bass and musk-alonge. Last season the water was so high that fishing was not so good as usual, but if we could not catch fish we could at least

see them. One night 3 of us rowed out in front of camp and held 2 bicycle lamps so that they reflected into the water, showing us large numbers of bass and muskalonge. One big fish jumped clear over the boat. We thought it would be profitable to set night lines, so the next day we baited about 100 hooks and as soon as it became dark we took the lines, anchors and floats and started out to set them. Just then 2 men walked out from the road and stood watching us. We knew it was against the law to set night lines. Finally one of the men said, "Well, they are out there for no good anyway." We knew we were in for a fine of \$25 apiece, so we pulled for the inlet, jumped ashore, ran about a mile to the railway station and returned to camp from another direction, taking off our sweaters, so the supposed wardens would not recognize us. The camp was all lighted up and the ladies were sitting around outdoors. Wiping the perspiration from our brows, we looked out on the lake and beheld our supposed fish wardens spearing by torch light.

T. W. Kelley, Erie, Pa.

ANSWER.

I am surprised that you, or any one else claiming to be a sportsman, should deliberately engage in a method of fishing that you know to be illegal, and I trust that on further reflection you may decide never again to violate a game or fish law, no matter whether in danger of discovery by an officer or not.

#### TRANSPORTATION COMPANIES PLEASE READ.

The following letter explains itself:  
General Manager,

Lake Keuka Navigation Co.,  
Hammondsport, New York.

Dear Sir:

A member of the League of American Sportsmen, in Rochester, has sent me a leaflet, which bears the signature of your company, showing on one side a picture of 2 men and a lot of trout laid out on the ground. On the reverse side is a statement that these 56 lake trout weighed 164 pounds, and that they were caught in a few hours.

My correspondent writes a severe criticism of your company for exploiting the work of the 2 fish hogs shown in this picture, and you may rest assured that this circular will impress all clean, decent sportsmen who see it in the same way that it does him and me. For many years it has been the custom of certain transportation companies to send out such pictures in the way of advertising their respective territories; but of late, a number of companies have quit this entirely because they have found that instead of attracting good

sportsmen, such documents repel them. I am the editor and publisher of RECREATION, a magazine which has a circulation of 65,000 copies a month, and I rarely miss an opportunity of publicly rebuking men who make such catches of fish as are shown in this picture, or who kill excessive numbers of game and then have themselves photographed with it. Such exhibitions are repulsive and disgusting to decent sportsmen and the sooner all managers of transportation companies learn this the sooner will they succeed in securing the approval and the patronage of the better class of sportsmen. Yours truly,  
G. O. Shields.

#### FISH HOOK BOOK.

726,509.—Combined Card and Book for Holding Fish Hooks. Albert W. Connor, St. Louis, Mo., assignor to Simmons Hardware Company, St. Louis, Mo., a Corporation. Filed December 22, 1902. Serial No. 136,094.

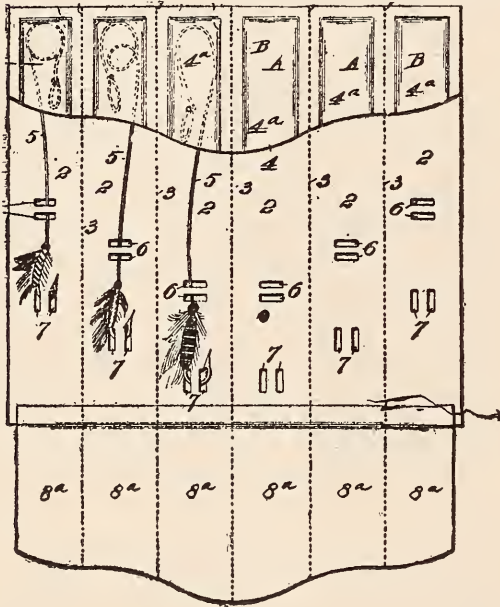

Claim.—I. A combined card and book for fish hooks, the card divided into sections by perforations, a single flap provided with perforations coincident with the perforations of the card, gummed to the body of the card at several points to form a plurality of pockets at one end of the card to receive the loop ends of the leaders, and a single flap at the other end of the card also provided with perforations coincident with the perforations of the card and adapted to be folded over on to the body of the card to cover the hooks.

#### SCORES HANSON.

From all I can learn, your remarks concerning Hanson, the Massachusetts fish hog, whom you so appropriately roasted

in April RECREATION, were well timed. His more conspicuous personal qualities are self conceit and a tendency to slop over. The first named prevents his having a realizing sense of his frequent indiscretions, while the second is continually leading him into new difficulties. After being forced to pay a large sum in a suit for slander some 2 years ago, he had the sublime nerve to run for the city council at the last municipal election. Needless, to say, he was snowed under. Now comes this show up of his sportsmanship in RECREATION, and we can easily imagine the rest. Just how much publicity of this type he can stand and refuse to accept the lesson is, of course, a problem; but it is safe to say he has enough "to hold him for a while" and that caution and moderation in sport will have a significance new to him.

It is pleasant to find the enlightened and superior Swedish residents in universal support of RECREATION's position and to hear, as I have heard, a generally expressed sentiment that Hanson got what he needed most—a call down.

Subscriber, Worcester, Mass.

#### GRAHAM WAS DEFEATED.

Your article in the June number of RECREATION, entitled "Salt Porkers," dealing with the extraordinary catch of 2,304 pounds of kingfish in one day by ex-Congressman William H. Graham and his friend, and the sale of the fish afterward to a fish dealer, concludes with the statement that Mr. Graham's election to Congress is a disgrace to the sportsmen of Pittsburg and vicinity. Mr. Graham was defeated for Congress last November by the well known sportsman, George Shiras, III, whose work with the camera and wild game photography is so often commended in your journal. Kindly make the above correction in justice to all true sportsmen of Pittsburg and vicinity.

Meredith R. Marshall,  
Pittsburg, Pa.

#### YIELDED GRACEFULLY.

A farmer in this vicinity posted a stream running through his lands with the usual notices forbidding fishing. But in his case prohibition did not prohibit. For 2 seasons he tried valiantly, but vainly, to protect the stream, and prosecuted several trespassers without obtaining satisfaction. The third year he retired from the contest and tacked on his sign boards the following:

Notice!

"Fish and be Damned!

"Dig worms anywhere in the garden."

T. A. Waterman, Johnson, Vt.



## GUNS AND AMMUNITION.

Anybody can shoot all day, but a gentleman will quit when he gets enough.

### THE EXPERIENCE OF J. D. BUCK.

King and Bartlett, Maine.

Marlin Fire Arms Co.,

New Haven, Conn.

Dear Sirs: I had an experience with one of your .30-30 rifles last fall, and as I am highly pleased with the outcome, I think it but just I should tell you about it.

There had been no rain for many days; the fallen leaves had become so dry and crisp that but little care was required for one to keep at a distance from all things one wishes to avoid. I had been roaming several days over the higher ridges, trying my antlers against sundry saplings and longing for a chance to test them in conflict with an antagonist worthy of them and me.

On the day of which I am telling I left my usual fall haunts on King and Bartlett mountain and went to lower ground. I circled around Little King lake and took to the top of the "horseback," which extends for a way parallel to Spencer stream. The day was bright and the sky cloudless. By the middle of the forenoon it was so hot that had there been a few black flies pestering me, I should have thought it surely was lily-pad time. As I weigh something like 300 pounds, my exercise had warmed me up and I began to be uncommonly thirsty. On one side of where I stood was low ground with almost stagnant and unpleasant tasting water; while on the other side was the sparkling, cool Spencer stream. I immediately started for the good water, keeping a sharp lookout for anything suspicious.

I had just reached the bank of the stream and was putting my head down to drink when a strange looking log, with a squat, thick, limblike growth sticking up at each end, came silently and swiftly around the bend above me.

Great guns, how it startled me! The log swung instantly head toward me. I could not make out just what it was, although I studied it carefully while it drifted swiftly toward me. There was a movement in the forward hump and I could see a smaller limb, with a little black hole in its center, which was pointed directly below the handsome patch of white on my throat.

"Now give it to him, Belcher!" came from the rear stump, and I suddenly realized that the log was a canoe, and what I had taken for squat limbs were in reality those horrid smoky smelling beings that walk on their hind legs and are called men. I thought my doom was sealed and even when I heard a sharp little click, such as one pebble makes when falling on another,

I did not have power to move, even to save my life.

"Jack in another," came from the rear again, and the man in front made a louder clicking.

"Dod blast the blank, blank thing; it's stuck!" the front man said. A shiver ran over me, I came to myself and with 2 mighty bounds was back in the thicket, well hidden and safe.

My curiosity caused me to linger a few minutes in the vicinity, and I learned from what the men said, although much it would never do to repeat, that the man in the stern had warned his companion to get ready for just such an opportunity as that which I gave them, and was taking him severely to task for not having had his rifle loaded. The other asserted in no uncertain tones that he had filled the magazine with cartridges and had pumped one into the chamber, or at least he had worked the lever, and, of course, supposed he had loaded the weapon. He went on to say that I had stood like a blamed fool while he had snapped once and thrown down the lever to reload, and had the action worked properly my name would surely have been Dennis.

I gathered that the rifle was made by you, was brand new, and although they decided it wasn't fit to take into the woods, yet it meets not only with my entire approval, but also the hearty commendation of those of my friends to whom I have related this incident.

May your business so increase that in the years to come every hunter who journeys this way will carry one of your rifles!

Yours thankfully,

James Dandy Buck.

### A .303 TARGET.

I am much interested in guns and ammunition, and that is where I commence to read RECREATION as soon as I have taken a look at the pictures. I often see the question asked, "What is the best all around rifle?" The question implies a gun to use on large game and on small game as well. I am partial to the 303, as the cartridge is, to me, the best for large game up to the 30-40. If the 303 is large enough for the heavy shooting, surely the 100 grain bullet and 3 to 5 grain miniature powder is small enough and cheap enough for anything; and I have found it accurate for close work. With my first 303 I shot one inch to the left and one inch low for every 10 yards. That called for a separate

sight for those loads. Then I got a 30-30 but had the same trouble. Now I have a new 303 octagon Savage and the line is so nearly the same I do not use any extra sight. It does fairly well, as per target enclosed, when you take into consideration that I am an old man and did not use a dead rest although I did steady the muzzle on a twig.

I find a great difference in different makes of cartridges for the same gun; for instance, for 303 one make measures less than 308, although the caliber of a 303 measures 308. The bullet should fill, to get all the benefit of the gas and rifling. The full jacket of the same company's make measures .311. Why this discrepancy? If .311 is right for full jacket, what is wrong about having same size for soft nose, for this is the game bullet and we need all the force and tearing power possible for large game. Then it does not stop too quickly with these small calibers. The smaller copper jackets do not take the same line vertically or horizontally. We are too apt to condemn a good gun because we have bought a cartridge not well adapted to the gun. In order to get loads that take same line I have been obliged to buy one make of expansive and another of full jacket. The new Savage rear sight will simplify matters somewhat in the matter of different loads.

I have yet to find a company so willing to do all that is right in regard to their guns as the Savage Arms Co. I had one of their guns that was faulty to some extent, and I wrote them in regard to it. They wrote me to send the gun in, and they put in a new barrel, a new cartridge carrier and refinished the gun throughout, returning it free of charge. I only asked that the chamber be changed slightly. The magazine had always been satisfactory; but the new carrier is an improvement to anyone who is careless in handling the gun. I could not but compare the action of the Savage Company with

that of the Snarlin people, as reported when their guns are sent back.

The enclosed target was made at 30 yards without going to target, and with the same sight and no change from 100 yards. This knocks my former theory out, for neither of my other rifles would have put the lead nearer than 3 inches of the center of mark. Some one tell why.

Stubb, Orwell, Ohio.

#### DEFENDS THE PUMP GUN.

I saw a scathing letter in RECREATION signed "Double Barrel," against the pump gun, which might have been written more guardedly and have conveyed the desired effect. The pump gun is the gun for those who know how to use it properly. For instance, when a covey scatters, the user may come on a pair, get both, and another may get up at a little distance which possibly he may also bag; but the average shooter fires to kill, not to wound.

I have had experience at all sorts of game in Scotland, including pheasants, partridges, black game, woodcock, ducks, snipe, hares and rabbits. Reckless shooting at wide ranges, say 50 yards and upward, is disliked, and if persisted in results in the shooter being omitted from the next shooting party.

I have had opportunity of seeing battues where the birds came overhead at a great pace and the shooters were crack shots who fired anywhere from 5,000 to 15,000 shots a year. A shooter would have 3 double barrel guns and 2 loaders beside him and would hit bird after bird in the head, leaving the body fit for table use and not a mess of bones, lead, feathers and flesh. I mention this as I consider the head the proper part to shoot at and it is a small target at 30 or 40 yards.

I have killed a pair of birds at a moderate range with one shot or a bird at long range, but in both instances it was met with criticism. My opinion of true sportsmen in this country, whether they use the pump gun or the double barrel, is that they lack nothing, comparing them with British sportsmen.

As regards W. E. Heist's statement that a charge from a 16 bore gun goes faster and does more effective killing than from a 12 bore, I consider that nonsense. Charge and loading have a lot to do with the effectiveness of a gun, but in 99 cases out of 100 it is the man who is at fault.

In India 28 bores are largely used for shooting snipe; weight  $5\frac{1}{2}$  pounds, charge, 28-30 grains G. C. or Shultze powder and  $\frac{3}{4}$  ounce shot. I have had experience in bringing some of those smart little gentlemen to bag. I have had to wait often on lost birds till the retriev-

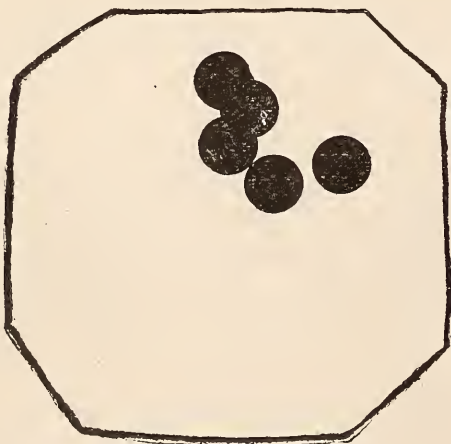

ers brought them to bag, the result of a long chance shot, which caused vexation among the party of shooters. If deer shooters would go after a good head with horns which, if properly mounted, would be a pleasant reminder, instead of killing does in the majority of cases, it would be preferable.

J. L. Tait, Holyoke, Mass.

#### THE SAVAGE COMPANY REPLIES.

In the March issue of RECREATION W. A. Cone denounced a Savage rifle and the makers thereof, in severe terms. When the Savage people read the article they wrote me as follows, regarding it:

We have always understood that RECREATION was a debating ground on which sportsmen might air their complaints, advance ideas and suggestions. Anything that has been written about our goods, good or bad, we have taken in the right spirit, and we intend to do so in future.

We are aware that in all man's work nothing is perfection, and that there are as many opinions as there are minds. RECREATION is the only journal that caters to the ideas and opinions of the sporting public. You have certainly built up the magazine on these grounds, and, of course, the protection of game. Your work on these lines must always redound to your credit. Your work is also, to a certain extent, influencing other sportsmen's journals, although they would dislike to acknowledge it. We often notice that they omit game hog photographs, which accompany some writer's vainglorious description; and the explanatory notes under such illustrations as they now publish are often modified far beyond their former tones.

While you have lost the ads of a few manufacturing concerns, who have become piqued at adverse criticisms, on the whole you should be the gainer, because of the general interest these discussions have created throughout the country.

We would never dream of withdrawing our ad because of your publishing criticisms against our arm. On the contrary, we have always used any criticism that has appeared for the purpose of obviating the troubles and faults that will crop out in any manufacturing business.

We are now making improvements in our rifles, slight, perhaps, in themselves, but always important, that have been suggested by readers of RECREATION.

We have gained a great deal of business and reputation by your publishing so many communications from the owners of Savage rifles who are well satisfied with them.

Savage Arms Company.  
Arthur Savage, Managing Director, Utica,  
N. Y.

#### PISTOL POINTS.

What is the best manner of holding a revolver? How is it possible to find out if the bullets are shaved in passing through the barrel? How can I tell whether the barrel is loaded, and how can leading be removed? Would it be advisable to put a little gun grease on each bullet used?

Harry Aughe, Dayton, O.

#### ANSWER.

The correct manner of holding a revolver is to grip the handle firmly with the thumb extending horizontally along the frame on the left hand side and the trigger finger resting lightly on the trigger when the hammer is set. The revolver should not be grasped so tightly as to cause the hand to tremble, but with just a firm, comfortable grip. To get good results, it is necessary to hold the weapon with the same degree of firmness and in identically the same way for each shot; otherwise there will be variation in the elevation. The secret of good shooting is to press the trigger gradually and let the revolver off with a squeeze of the hand rather than by a direct pull, keeping the sights in correct alignment while the pressure is being increased on the trigger.

"Shaved bullets" are bullets shot from a revolver in which the chamber of the cylinder does not align perfectly with the bore of the barrel. This is not likely to happen with a revolver of standard make. You can determine whether the bullet is shaved or not by shooting it into a roll of cotton batting or soft cloth. Either material will not distort the bullet.

Leading of the barrel can be readily seen by any one who has had practice in inspecting barrels. Originally the grooves, as well as the lands, are bright when thoroughly clean and free from oil. When leaded, the grooves will have a duller finish apparent on the surface. A good way to remove a slight coat of lead is to fill the barrel with mercury and let it stand until the lead coating is removed. In shooting important matches, many expert shots use brass brushes, which are effective in removing any leading that may occur while shooting. If the bullets in the cartridges are greased with gun grease before firing them, the ammunition will work much cleaner than otherwise.—A. L. A. H.

#### LOADS.

Some readers of RECREATION owning 30-30 rifles have possibly wished to use light loads for small game or for short range target work without having to buy special bullet molds, etc. I have been experimenting a little, and have at last found a load that is as accurate up to 100 yards as any cartridge in the market. I use the regular 30-30 shell, with  $7\frac{1}{2}$  grains DuPont

No. 1 Smokeless Rifle powder; and, instead of using the 100 grain bullet, I use the full sized bullet cast by the regular 30-30 tool, 10 parts of lead to one of tin. This makes an excellent cartridge for shooting rabbits, squirrels, and for range work up to 100 yards. There is hardly any report, and no leading of the gun. Of course all 30-30 rifles, when using lead and tin bullets, should be cleaned after 8 or 10 shots, to prevent leading.

I had a Marlin rifle, but got rid of it as quickly as I could. The person I sold it to also disposed of it immediately, saying it was not fit to kill pigs with. I belong to the South Side Rifle Club, which bars Marlin rifles; Winchester, Savage and Stevens being the only guns used. Shells of 30-30 caliber loaded with low pressure powder, have to be resized when used in Marlin rifles, but never when used in the Winchester.

For a more powerful cartridge, and one as accurate as the 32-40 and the 38-55, at 300 yards, use 15 grains DuPont No. 1 Smokeless Rifle powder, and the regular sized bullet, cast, 10 to one. When trying these cartridges use the Lyman rear sight, as the 2 loads, having a trajectory not nearly so flat as that of the regular high pressure shells, require greater elevation than can be obtained with an ordinary rear sight.

H. L. Yancey, Racine, Wis.

#### DISAGREES.

In RECREATION I notice S. B. H., of North Rome, Pa., gives his opinion to S. O. Ingalls in regard to fox loads and to Nimrod, in regard to 28 and 30 inch guns. S. B. H. says his experience with a 38 inch barrel has been that it will shoot 1-3 stronger than the 28 inch. Therefore, if an extra 2 inches over a 28 inch gun will shoot 1-3 stronger, a 32 inch ought to shoot 2-3 stronger, which would leave the 28 inch gun out of it entirely, according to mathematics. What a gun the 34 inch would be compared with a 28 inch, according to S. B. H.! My experience has been that a 30 inch may throw shot 2 inches farther than a 28 inch. S. B. H. says the longer powder is confined the more force it has. I again disagree. The harder it is confined the better results it will give.

D. S. Bodge tells us all about that 22 of his. It must be a terror to penetrate 36 inches of oak plank. Mr. Bodge must have shot down hill. Those silvertips he speaks of must have been young raccoons, and it is a wonder they did not get savage when he commenced on them with a 22. A Montana barroom bum threatened to shoot a cowboy with a 22 and the cowboy said,

"If you shoot me with that and I find it out I'll kick the d— out of you."

Will some of the Middle Falls readers please awake Mr. Bodge? He has been dreaming long enough.

F. M. O., Anaconda, Mont.

#### ENDORSES ROBIN HOOD POWDER.

Robin Hood smokeless powder for shot guns is strong, clean and quick, and the manufacturers have resolutely kept out of the combine into which the Peters and other cartridge companies have gone. Robin Hood powder took my fancy from the start and I have used many hundred loads of it with excellent results. It is a moist burning powder, and shoots with great velocity and little recoil. It is loaded by bulk measure and as high as  $3\frac{1}{2}$  and  $3\frac{3}{4}$  drams may be fired in a 12 bore without discomfort. The Robin Hood people are also putting on the market their factory loaded shells and these can now be obtained from local dealers. This powder is strictly an Eastern product, made in Vermont and little known in the West. However, it is safe to say that it will be received with satisfaction by sportsmen who want a good thing. The primers in the Robin Hood factory loads are made by Eley, in London, and are quick and strong, making a hard hitting, quick load. If any of the Eastern readers of RECREATION have ever used Robin Hood I wish they would let me know how they like it, and we can compare results.

Chas. H. Morton, Topeka, Kans.

#### CONDEMNS THE MARLIN.

As a sportsman, I was greatly impressed with the truth and importance of Mr. A. L. Vermilya's article in January RECREATION. It has been my fortune for the past 5 or 6 years to do some big game shooting, and last summer a friend and I decided to seek bears in the mountains of Northern California. We were armed with 2 Winchester and a Savage, but my guide shot a Marlin. It was my first and I trust will be my last experience with that gun. After leaving Sisson we crossed several ranges of the Sierra Nevada mountains and at an altitude of about 5,000 feet encountered our first game, 2 rattlers. My guide attempted to kill them, but his rifle jammed completely. Our next experience with the gun was on Cliff lake, where he lost a golden cause. Now, had it been his misfortune to meet a grizzly under similar circumstances, the result we might well imagine. If we sportsmen are shooting large and dangerous game our lives frequently depend on the rapid and accurate action of our fire arm; and when we realize the serious consequences that might follow the jamming of

a rifle at a critical moment, can we take the chance?

Jas. C. Stark, M.D., West Phila., Pa.

#### DEFENDS THE SAVAGE.

Replying to G. W. McHay, Kelseycy town, Minn., who criticised the Savage, I have owned 2 .303 Savage rifles, and have never used any rifle more to my liking. For shooting, neatness and perfection of balance, they are unequaled, while for penetration the Savage people guarantee 50 inches of white pine, with full mantled bullet of their own make; and their word is good. The soft point will penetrate a 5-16-inch steel boiler plate. If the trigger lock works loose and the trigger pulls too hard, a remedy is to take off the buttstock, exposing most of the lock. Cut a piece of rubber the right thickness to fit in the slotlike screwhead in the rear of lever lock; or a piece thick enough to make the trigger lock extend enough to work at the desired pressure. To make the trigger pull easier, hold trigger back with finger, which will pull the sear down until it can be reached with a small file. Round off the corner next to the magazine slightly, closing the action, now and then trying the pull until it suits. It may be cut down to almost a hair pull if desired. This was my treatment for 2 Savage rifles.

C. E. Wilson, Mt. Carbon, Colo.

#### SMALL SHOT.

In experimenting with a 30-30 Winchester carbine, using Winchester and U. M. C. factory-loaded, soft point bullets, I fired at  $\frac{3}{8}$  inch iron plates, at 10 paces. The bullets made dents  $\frac{1}{4}$  inch deep and  $\frac{1}{2}$  inch in diameter. Firing at a  $\frac{1}{4}$  inch iron plate, the same distance, the bullets cut clean holes  $\frac{1}{2}$  inch in diameter and carried the pieces of iron punched out 2 inches into hard pine. Reloaded shells, using factory-made bullets and 27 grains Savage smokeless powder, would not go through  $\frac{1}{4}$  inch iron. Went through 3-16 iron after bending the plate badly. Was this the fault of the powder, or because the Winchester reloading tool does not crimp the bullet tight in the shell? Bullets fired into soft pine mushroomed beautifully, but one fired at a 16 inch cedar telegraph pole went through it and 4 inches into a clay bank without expanding. The soft point was worn off even with the copper jacket, which goes to show that you can not tell what a bullet will do.

W. A. Trussell, Chicago, Ill.

Can you tell me the penetration, at 100 yards, of the 56-50 Spencer cartridge made by the Winchester Company? Can shells of

that caliber be reloaded with smokeless powder?

Bernard Andrews, New Durham, N. J.

I referred this to the Winchester people, whose reply follows:

The penetration of the 56-50 Spencer at 100 yards we find to be 8  $\frac{7}{8}$ -inch pine boards. This, of course, might vary considerably as the lumber varies, but think this is a good average result. With regard to reloading these shells with smokeless powder, we can only say that it has never been done, and in our judgment it would be unwise to do so, as the initial pressures generated with smokeless powders would probably be great enough to rupture the shell about the head. This cartridge was, of course, made up for black powder, and no attempt has been made to adapt it to smokeless.—EDITOR.

I notice in the February number of RECREATION "Enrique" claims that the Savage miniature bullet is worthless beyond 25 yards. After reading that, I took my model '99 Savage, and went out to prove that he is wrong. The following was the result: Four bullets were fired at a target 100 yards' distant; one struck  $\frac{1}{2}$  inch from the center, one 1 $\frac{1}{2}$  inches from the center, one 2 $\frac{3}{4}$  inches and one 3 $\frac{1}{2}$  inches. I then fired 4 bullets at a target 150 yards distant. One bullet struck the target 1 $\frac{3}{4}$  inches from the center, one 3 inches, another 3 $\frac{1}{2}$  inches, and the 4th struck above the target. I then fired 2 shots with a 200-yard range. One struck 3 $\frac{3}{4}$  inches from the center, and the other missed the target, but struck above it.

All the bullets were the Savage miniature .303, and were fired without using a rest.

A. D. Ostrander, Franklin, N. Y.

I am not much of a hunter, nor a crack shot, but am fond of a good rifle. I have owned lots of them; Remingtons, Spencer, Maynard, Evans, Colt, Chaffee-Reece, Stevens, Hopkins & Allen, Sharps, Quackenbush, Springfield, F. Wesson, and most all models and calibers of repeating and single shot Winchesters. I now have a Winchester, '94 model, 30-30 carbine, and would not swap it for anything I ever used. It just fills the bill and is light and handsome. I use all kinds of loads, from 6 to 30 grains of either black or smokeless powders, and am satisfied that the little carbine is O. K. for any game to be found in New England. The Savage is also a great rifle. RECREATION is all right. Could not get along without it.

Leman Dawes, Harrison, Me.

I consider the Lee straight pull, 6 mm, the nicest little saddle gun, the longest

range and the quickest killer I ever used. I began 22 years ago in this same locality with a 44 flat Henry. Since then I have used all kinds of arms, including 30-30 Winchester, Marlin and Savage, and last and best, the Lee straight pull. I killed 2 bears last fall with the latter, smashing the skulls completely. I have made 4 hunts on the Western slope, and have killed most varieties of Colorado game. I never had trouble with the Lee or Marlin 30-30, much as the latter is condemned in RECREATION. Both arms are easy to clean, while if you are out in a wet snow or rain with a Winchester or Savage you can put in the rest of the day or night getting them in condition again.

Whort, Rosenberg, Tex.

The Peters Cartridge Co. gave a shoot at Carthage, Mo., Sept. 19 and 20, under the management of Sam Norton. Pump guns were plentiful and I took particular note of their working with Peters Ideal shells. With the Winchester pump no trouble was experienced; but the Marlins failed to extract the Ideal shell in almost every case. I think the Ideal shell would work well in any gun if it had a heavier rim. On the last day of the shoot I used 2 boxes of Peters Ideal shells loaded with  $3\frac{1}{4}$  ounces of shot. Several of the shells blew off just above the base.

J. W. Dawson, Joplin, Mo.

I noticed an article in November RECREATION from J. C. Davis, of Etna, Wash., saying that he failed to get his deer after it had been shot through both shoulders with a 30-30 Marlin. That shot should have dropped the deer in his tracks, but it is surprising how far an animal will sometimes travel after receiving a mortal wound. I do not think the length of the barrel had anything to do with this particular shot, but if Mr. Davis wishes a rifle for heavy shooting he should hark back to the 40-65, 45-70 or 45-90 Winchester.

Charles Cooley, Chicago, Ill.

I read your magazine each month with great interest, especially the gun and ammunition department. I am sorry to see the Peters Company acting as they are. They fully deserve all that has been said of them and more. I find their shells unreliable, as many miss fire. The Winchester repeater shells are ideal, and give splendid results. If the Peters Company would only take advantage of the kindly criticism in RECREATION and remedy the defects in their goods instead of taking offence, it would be far more beneficial to them.

M. H. Davis, Fayette, Mo.

I should like to ask Double Barrel, who writes so disparagingly concerning the pump gun, if he is sure of killing his bird at every shot? As a rule, in wing shooting, the bird comes down at the first shot; but what if the second barrel should wound a second bird? With the pump there is a third shell ready to do a humane act. The pump is superior to the double barrel because it affords a 3 to 1 chance in killing the wounded bird or birds. For that reason I consider the pump the most humane gun on the market.

Repeater, Marblehead, Mass.

725,883.—Gopher Gun. Cortland Sims, San Jose, Cal. Filed November 13, 1902. Serial No. 131,138. (No model.)

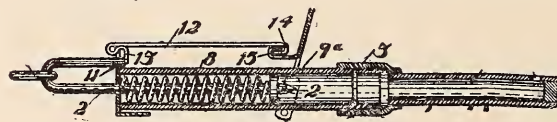

Claim.—1. A breech loading gun, consisting of a barrel, a firing pin and operative means therefor, said barrel having a closed muzzle end and a discharge at right angles to its axis, etc.

I notice in your April issue an inquiry from A. W. Crampton, St. Albans, Vt., about Robin Hood smokeless powder. I have used Robin Hood smokeless shells, both factory loaded and those I have loaded myself. I find them not only equal to Winchester and U. M. C. shells, but far better. I have had excellent results with their  $2\frac{3}{4}$  drams  $1\frac{1}{8}$  ounce  $7\frac{1}{2}$  shell loaded by Robin Hood Powder Co. for shooting blue rocks and  $3\frac{1}{4}$  load for game.

Harry Harrison, Rochester, New York.

Why is it dangerous to use smokeless powder in a black powder gun, if the quantity of smokeless used gives the same velocity?

Wm. Sweet, Ithaca, N. Y.

ANSWER.

There is no increase of danger in the use of the smokeless powders manufactured by this company over the dangers of black, if our loading instructions are followed strictly.

Laffin & Rand Powder Company.

I should like to hear from those who have had experience with the new Winchester special .32, .33 and .35 calibers, likewise the 38-72 box magazine. Which is preferable, the box or the tube magazine?

Roy E. Marston, Concord, N. H.

I should like to have owners of the Colt Patent new lightning sporting rifle give their experience in using that arm.

E. J. Pratt, Rushville, N. Y.

## NATURAL HISTORY.

When a bird or a wild animal is killed, that is the end of it. If photographed, it may still live and its educational and scientific value is multiplied indefinitely.

### MULE DEER AND BLACKTAIL.

I notice your remarks in RECREATION about mule deer being called blacktail deer. What are the distinguishing features of each? Is not a mule deer hornless? Are whitetail deer also mule deer?

RECREATION is doing a valuable work.

E. P. C., Santa Rita, N. M.

#### ANSWER.

Here are some extracts from "The Big Game of North America," which answer fully your inquiry as to the identity of the mule deer and the blacktail deer. Referring to these 2 species of deer the author says:

"In the Rocky mountains, where the true blacktail deer is not known, the mule deer is still called the blacktail deer. On the Pacific coast, where the mule deer ranges with the Columbia blacktail, it is known by its true name, mule deer, by which design-



Mule Deer.

nation it is also recognized by naturalists. The original habitat of the mule deer has not been much restricted since its first discovery, though it has deserted or become scarce on the Missouri river and other hunted localities where the white man has too much disturbed its seclusion. Its natural home is in the mountains, but it is found on the great plains, hundreds of miles East of them, where it most affords the broken and arboreous borders of the streams.

"West of the Rocky Mountains, the mule deer is met with almost everywhere. In the Coast range, North of San Francisco,

it is almost entirely replaced by the Columbia blacktail deer, and South of that point this variety entirely gives place to the California variety. In Oregon, Washington, and in British Columbia, the mule deer is met with, but not so abundantly as in the mountains farther East.

"In the face of civilization, the mule deer maintain their ground better than the elk. In flight, they do not run like the common deer, but bound along, all the feet leaving and striking the ground together. For a short distance the flight is rapid, but soon seems to lag. Once, when sitting on a crag in the Rocky mountains 10,000 feet above the sea, I watched a mule deer, which had been started by a companion, as it bounded through the valley 1,000 feet below. In a run of half a mile, he showed evident fatigue. That the labor of such a motion is greater than that of the long, graceful leaps of the common deer, must be manifest.

"The limbs of the mule deer are larger and coarser than those of the common deer. The mule deer are less agile and elastic in their motions, and are less graceful in form. Their large, disproportioned ears are their ugliest feature, and give tone to the whole figure.

"The summer coat is a pale, dull yellow. Toward fall, this is replaced by a fine, short, black coat, which rapidly fades to gray. As the season advances, the hairs of the winter coat grow larger, and so become more dense, as well as of a lighter color. Usually, in the forehead is a dark, bent line in the form of a horseshoe, with the toe downward. The brisket and belly are black, growing lighter toward the umbilicus; thence, posteriorly, a still lighter shade prevails, till, at the inguinal region, a dull white obtains. Between the thighs it is quite white, widening toward the tail. This white portion extends to one inch above the tail, where it is 6 inches broad. Lower, it is 8 inches broad, and lower still, between the legs, it contracts to 4 inches in breadth. Viewed posteriorly, this white patch is a conspicuous object. Below the knees and elbows, the legs are of a uniform dark cinnamon color."

The foregoing quotation is from the chapter on the mule deer.

Here is an extract from the chapter on the Columbia blacktail deer:

"By far the most common member of this family, on the Pacific slope, is the Columbia blacktail deer, so named because it



Black-tailed Deer.

was first noticed by Lewis and Clarke, while they were in the region of the great river of that name. This animal is to be met with from Lower California to Cook's Inlet, in Alaska. In the Rocky mountains and headwaters of the Missouri river, the mule deer is frequently mistaken by hunters for the blacktail. This mistake is pardonable, for the mule deer also sports some black on his fly-disturber, if it may be so designated. One of the infallible proofs of the distinctiveness of the 2 species is that the tail of the mule deer is naked on the under side, while that of the blacktail is entirely clothed with hair. In color, the female blacktail is almost identical with the male. The antlers of a full grown buck consist of 2 main beams, which spring backward and upward from the head, and from each of which spring one to 6 tines, according to the age of the individual. The antlers of this species are not nearly so large and majestic as those of the mule deer. When a blacktail buck is one year old he has 2 spikes rising from his head; when he is 2 years of age these spikes will each have a branch, and when he is 3 years old there will be 3 pommels to each horn. After this, the age of the animal can not be reckoned with any degree of certainty."

Judge Caton gives this description of the Columbia blacktail deer:

"Less in size than the mule deer. Short body and short legs. Ears large, but less in size than those of the mule deer. Eyes large and brilliant. Tail short and round. One-fourth of the circumference of the tail on the under side is white; the balance is a tawny dull black. The black is of the deepest shade on the lower part. Metatarsal gland between the tarsus and the middle of the leg is intermediate in size between those on the mule deer and those on

the Virginia deer. Tarsal gland much the same in size and form as on those 2 species, and a shade lighter than the surrounding coat; color of body a tawny gray, with white on back part of belly and inguinal region, extending to root of tail. The face is gray, with darker forehead. Under the head, white. Legs generally of a uniform dark cinnamon color, not a white hair to be found on them below the hock. Antlers once or twice bifurcated. Gait like that of the mule deer. Is found on the Pacific coast of the United States and British Columbia only; having the most limited range of all the deer found in the United States, and perhaps on this continent."

I trust these data may settle, in the minds of RECREATION readers, the question as to the actual difference in characteristics and in range between the mule deer, which is that found throughout the Rocky mountains, and the blacktail deer, which is the form found only on the Pacific slope.—  
EDITOR.

#### A BIRD WITH MANY NAMES.

If one is fortunate enough to be in the country during the lovely days of June, he can make the acquaintance of the merriest, happiest and most musical of the oriole family. Who can imitate or describe the song of the bobolink? The most rippling, cheerful, thankful little voice that ever soared to heaven. Robert Lincoln, as he is sometimes called, usually appears in New England in May, dressed in a most attractive wedding suit of black, buff and white. He is not so large as his brothers in the family (*Icteridae*) who are familiar to us, except the orchard oriole. He is not nearly so large as the American robin, who boasts 10 inches, for the bobolink measures only 6½ to 7. Yet he presents a striking appearance as he darts here and there in search of food. He has a black head, chin, tail, wings and under parts; buff edges to some of the tail and wing feathers, the rump and upper wing coverts being white; but the crowning glory of his attire is the buff spot on the back of his neck, which is described in "Citizen Bird" as looking like a cream cake baked just right.

Have you seen a bobolink's nest? It is said that "Whoever would find one must have the patience of an Indian, the eyes of a bird, and the cunning of a fox." The nest is usually placed in low meadows or hay fields and is composed of twigs and tufts of grass built loosely together. The clutch consists of 4 to 6 eggs, gray in color, with cloudy brown markings. The pair are too wise ever to fly directly into or out of the nest, but on wishing to enter they dive into the grass some distance from their home and



slip along beneath the waving, green tops, unperceived by the human eye.

The sojourn of the bobolink with us is short, and he is the first bird to leave the choir. Being a good little patriot, he waits for the Fourth of July celebration. Then he retires to the marshes, with scores of his own kind, and emerges in August a changed bird. In his place of seclusion he has left his entrancing voice and gay attire, and donned a traveling suit of brown, with a little yellow and white trimming, and a striped Tam o' Shanter. He can hardly be distinguished from his mate, who always wears a plain suit to avoid being conspicuous. The migratory spirit is upon him, and a long journey is in prospect, so he tries to tell us all about it, with his little metallic note of farewell, "Chink, tink, tink, chink." For a time he lingers among the wild rice swamps, and is known as the reed bird; but the autumn winds have whispered to him that the rice fields of South Carolina and Georgia are in perfection. The tall stalks of grain are "in the milk," and no daintier food could be desired by the most fastidious bobolink. Even those far off in Utah come back by way of the East, and travel South by the old pathway. What is this strange migratory instinct which Nature bestows on her winged children, which prompts these feathered mites to journey thousands of miles each year without chart or guide?

Our New England bobolink joins those of his kind, and together they travel, high above the earth, toward the South. Flocks of these sober, little brown birds arrive at the rice plantations, and though gunners and minders are there to frighten them off, yet the destruction to the crops is so great that the loss reaches millions of dollars annually to the planters. Some of the planters consume 100 pounds of gunpowder a day, often with only blank cartridges, to drive away these depredators. Fires are kept burning at night, but all in vain, for rice birds will risk their lives for a good meal. Of course, many a rice bird, or ortolan, as he is now called, is killed and served at dainty repast; while at the restaurants reed, or rice, birds sell for 50 cents a skewer. When in the early autumn one sees on the menu card, "Croustades of reed birds," let him remember that he is eating the joyous songster who fills our hearts with the uplift of his thankful spirit in the early days of summer.

Our little friend does not linger long at the plantation, for he has appointments with flocks of his kind from all parts of the United States to meet in Florida. It seems as if it were an autumnal convention of the bird with many names. When all affairs of this branch of the bird kingdom are settled, the travelers start for their winter home, the

majority going first to Jamaica. There nature has prepared a dainty repast for them in the seeds of the guinea grass. On this diet they grow so plump that epicures like them for the table, and they are known there as butter birds. If they go to Cuba, they are called *Chambergos*. The journey is not yet over, for they have no intention of wintering in the West Indies, because their ancestors never did so, hence they plume themselves for the long flight of 400 miles across the Caribbean sea to Venezuela. From there they hasten on to South-western Brazil, where they spend Christmas, hang up their stockings, and order their new spring suits of black, white and buff. The bobolink is one of the few birds that moult completely twice a year.

It seems as if they give themselves no time for rest, for they are back again in Florida quite early, where they are called May birds, and with a strange foreknowledge, they arrive at the rice plantations just in time to revel in the young, green shoots of the rice plant, which are peeping above ground. The planters are obliged to order out their minders to save their crops from utter destruction. By the middle of May our own little bobolink is wooing his mate in his Northern home, and planning his housekeeping in perhaps the same spot where we first made his acquaintance.

What a traveler he has been! He holds steam and electric cars in contempt. Unhampered by tickets or trunks, he has passed over hills and valleys, rivers and streams, cities and plains, a distance of 4,600 miles, to the South, and when the homing instinct asserts itself, he returns as fresh and gay as when he caroled his cheery songs to us a year ago.

Caroline F. Little, Brooklyn, N. Y.

#### A CAPTIVE CONDOR.

Two newspaper items recount interference with trolley and railway traffic in the United States by birds. In the first case a blue heron short circuits the city wires in Utica, N. Y.; and in the second an owl gets mixed up with a switch point on the Mobile & Ohio railway. Nothing so small as a mere handful of feathers could hold up a train on the Guayaquil & Quito railway. When the regular passenger train on the mountain division pulled into Alausi the other day, somewhat late, the train crew proudly displayed a condor, securely tied, and explained the delay by telling how this bird was found in a railway cut some miles down the line, occupying the space reserved for running trains, and unable or unwilling to leave; so the train hands roped it and brought it to the terminal station, where it now occupies a foremost place in the growing collection of Ecuadorian fauna at headquarters' camp.

From beak to end of tail the bird measures 4 feet, one inch, and for the wing expanse 10 feet. This is rather larger than the measurements usually given in reference books. A condor killed in Riobamba, Province of Chimborazo, Ecuador, in the summer of 1901, measured 14 feet from tip to tip. For a bird supposed to spend most of its time sitting around on inaccessible and lofty crags, or in giving the American eagle points on high flying, it shows little fear, rather indifference, in the presence of man, allowing its neck and head to be stroked and its wings to be handled. A bite from its beak, with which it cracks small bones, would be no joke, so this familiarity is not without a spice of risk. In its wild state its food is probably the same as that of other sorts of carrion birds, as it lacks the hunting traits of the hawk and eagle kind, and a look at its feet, which resemble nothing so much as those of the domestic turkey, is proof that it could never seize and carry away a living animal. The altitude above the sea where this bird was captured is about 5,000 feet, and others have been seen and shot in the same vicinity, but the condor doubtless ranges much higher, if we are to believe Malte-Brun (Book 86), who says of this huge bird of the Andes that his "broad pinions bear him up in the atmosphere to the height of more than 20,000 feet above the level of the sea."

Dr. S. A. Davis,  
Chief Surgeon, G. & Q. Ry. Co.,  
Alausi, Ecuador, S. A.

#### HABITS OF THE SQUIRREL.

There are few squirrels in this locality and those are of the fox species only. Once I was hog enough to kill every one I could find, but of late years I have been as big a crank the other way, giving them all the protection possible. In the timber opposite my house a few of the pets make their homes. Being undisturbed, they have become quite tame and are daily visitors to the yard, skipping about the trees or gathering nuts scattered on the ground for them. After they have eaten their fill they busy themselves in burying the remainder. They dig little holes in the ground or snow with their fore feet, and after pushing the nut down, root the dirt back with their noses and pat it down with their fore paws, so that a keen eye is required to locate the *caches*. In drinking at the horse tank, they dip their noses in the water and lap it up just as a dog does. They also eat salt, and often we see them gnawing at an old salt barrel head. If no nuts are scattered for them they unearth those buried on former days. They are selfish and sometimes have lively fights over a nut. I

favor a law to prohibit killing squirrels. I endorse the L. A. S. and enjoy the manner in which you roast the porkers. Is there a law in Indiana prohibiting the use of ferrets? Several are kept here. Game is not abundant.

James P. Ewing, Tracy, Ind.

#### NATURAL HISTORY NOTES.

I think it is rats and porcupines that gnaw the elk and deer horns after they are shed, and that most of this is done the first winter the horns lie out. I have seldom seen antlers gnawed, but have seen many skulls with horns attached that were badly eaten. You can find hundreds of shed horns in this country that have not been touched, and as horns are not shed till March or later it seems clear that the varmints eat them the first winter they are dropped. But few elk have been killed here for the teeth. A few have been killed for bear bait, but we have not had any game wardens here till last year, and they were not allowed any salary. We all know how poorly men work without pay.

Go after Marlin and his shooting irons till he makes them right. They will not always feed as they should.

Felix Alston, Irma, Wyo.

R. B. Stowers says he never saw a squirrel drink. I have never seen them drink water, but have seen their tracks to open water in winter. I have more than once seen them sitting on spiles, helping themselves to the sap as it ran down into the bucket. If a squirrel can not get a tree already tapped, he does the job himself. I have watched them do it. Selecting a small tree or the limb of a large one, the squirrel gnaws through the bark and a little way into the wood, near the top of the tree or limb, and lets the sap run down. Then, starting at the bottom, he climbs slowly up, licking the sap off as he goes, or sits below the notch and catches the sap as it runs down. Do not kill the squirrels.

C. F. Coleman, Winnipeg, Canada.

I have read with much interest the articles in RECREATION about coons. I have hunted coons 4 years, and not until last fall have I heard a coon call. I caught one in a trap and he made a noise something like the call of a screech owl. I had a tame coon, but he never uttered any kind of a call. I have some good coon hounds and should like to correspond with other coon hunters who are readers of RECREATION.

Ben Wiethorn, Watson, Iowa.

# THE LEAGUE OF AMERICAN SPORTSMEN.

## GENERAL OFFICERS

*President*, G. O. Shield, 23 W. 24th St., New York.

*1st Vice-President*, E. T. Seton, 80 West 40th St., New York.

*2d Vice-President*, W. T. Hornaday, 2969 Decatur Ave., Bedford Park, N. Y.

*3d Vice-President*, Dr. T. S. Palmer, Dept. of Agriculture, Washington, D. C.

*4th Vice-President*, A. A. Anderson, 80 West 40th St., New York

*5th Vice-President*, Hon. W. A. Richards, General Land Office, Washington, D. C.

*Secretary*, A. F. Rice, 155 Pennington Ave., Passaic, N. J.

*Treasurer*, Austin Corbin, of the Corbin Banking Co., 192 Broadway, New York City.

## ALASKA DIVISION.

Dr. E. M. Rininger, Chief Warden, Nome.

## ARIZONA DIVISION.

M. J. Foley, Chief Warden, Jerome.

## ARKANSAS DIVISION.

W. R. Blockson, Chief Warden, Eureka Springs.

## CALIFORNIA DIVISION.

Dr. David Starr Jordan, Chief Warden, Leland Stanford University.

## COLORADO DIVISION.

A. Whitehead, Chief Warden, 303 Tabor Building, Denver.

## CONNECTICUT DIVISION.

Hon. F. P. Sherwood, Chief Warden, Southport; Dr. H. L. Ross, Vice-Warden, Canaan; H. C. Went, Sec.-Treas., Bridgeport.

## DISTRICT OF COLUMBIA DIVISION.

C. H. Townsend, Chief Warden, U. S. Fish Commission.

## FLORIDA DIVISION.

W. W. K. Decker, Chief Warden, Tarpon Springs

## GEORGIA DIVISION.

J. J. Doughty, Chief Warden, Augusta.

## IDAHO DIVISION.

L. A. Kerr, Chief Warden, Kendrick

## ILLINOIS DIVISION.

M. D. Ewell, M.D., Chief Warden, 59 Clark St., Chicago; F. M. Taber, Vice Warden, 144 Kinzie St., Chicago; G. C. Davis, Sec.-Treas., 123 S. Central Ave., Austin.

## INDIANA DIVISION.

Frank L. Littleton, Chief Warden, 30½ East Washington St., Indianapolis; J. J. Hildebrandt, Vice Warden, Logansport; T. J. Carter, Sec.-Treas., State House, Indianapolis.

## IOWA DIVISION.

Carl Quimby, Chief Warden, Des Moines; C. C. Proper, Sec.-Treas., Des Moines.

## KANSAS DIVISION.

O. B. Stocker, Chief Warden, Wichita; A. J. Applegate, Sec.-Treas., 113 E. 1st St., Wichita

## KENTUCKY DIVISION.

Geo. C. Long, Chief Warden, Hopkinsville.

R. L. Brashear, Sec.-Treas., Bowling Green.

## MAINE DIVISION.

Col. E. C. Farrington, Chief Warden, Augusta.

## MARYLAND DIVISION

J. E. Tylor, Chief Warden, Baltimore.

## MASSACHUSETTS DIVISION.

Heman S. Fay, Chief Warden, Hazleton Block, Marlboro; J. E. Tweedy, Vice-Warden, North Attleboro; A. C. Lamson, Sec.-Treas., 194 Main St., Marlboro.

## MICHIGAN DIVISION.

J. Elmer Pratt, Chief Warden, Grand Rapids; R. S.

Woodliffe, Vice-Warden, Jackson; A. B. Richmond, Sec.-Treas., Grand Rapids.

## MINNESOTA DIVISION.

Dietrich Lange, Chief Warden, 2294 Commonwealth Ave., St. Paul.

H. A. Moigan, Vice-Warden, Albert Lea; Prof. O. T. Denny, Sec.-Treas., St. Paul.

## MISSOURI DIVISION.

Bryan Snyder, Chief Warden, 726 Central Bldg., St. Louis.

## MONTANA DIVISION.

Professor M. J. Elrod, Chief Warden, Missoula; Sidney M. Logan, Vice-Warden, Kalispell; R. A. Wagner, Sec.-Treas., Bozeman.

## NEBRASKA DIVISION.

Fred. E. Mockett, Chief Warden, Lincoln; P. O'Mahony, Sec.-Treas., Lincoln.

## NEVADA DIVISION.

Dr. W. H. Cavell, Chief Warden, Carson.

Geo. W. Cowing, Sec.-Treas., Carson.

## NEW HAMPSHIRE DIVISION.

Dr. A. F. Barrett, Sentinel Bldg., Keene,

Sidney Conant, Sec.-Treas., Keene.

## NEW JERSEY DIVISION.

Percy Johnson, Chief Warden, Bloomfield; Dr. W. S. Colfax, Vice-Warden, Pompton Lakes; I. V. Dorland, Sec.-Treas., Arlington.

## NEW MEXICO DIVISION.

W. M. Borrowdale, Chief Warden Magdalena.

## NEW YORK DIVISION.

John R. Fanning, Chief Warden, Powers' Bldg., Rochester; Col. R. E. Moss, Vice-Warden, Wallack's Theatre, New York City; Dr. C. C. Curtis, Sec.-Treas., Columbia College, New York City.

## NORTH DAKOTA DIVISION.

Dr. W. D. Jones, Chief Warden, Devil's Lake.

## OHIO DIVISION.

W. E. Gleason, Chief Warden, Mitchell Bldg., Cincinnati; A. C. Thatcher, Vice-Warden, Urbana.

## OKLAHOMA DIVISION.

W. M. Grant, Chief Warden, Oklahoma City.

## ONTARIO DIVISION.

C. A. Hammond, Chief Warden, Box 701, St. Thomas; D. L. Mells, Sec.-Treas., St. Thomas.

## OREGON DIVISION.

Robert F. Kelly, Chief Warden, Box 188, The Dalles; C. B. Cushing, Sec.-Treas., The Dalles.

## PENNSYLVANIA DIVISION.

C. F. Emerson, Chief Warden, 189 N. Perry St., Titusville; Hon. C. B. Penrose, Vice-Warden, 1723 Spruce St., Philadelphia; E. Wager-Smith, Sec.-Treas., 1026 Ridge Ave., Philadelphia.

## RHODE ISLAND DIVISION.

Zenas W. Bliss, Chief Warden, 49 Westminster St., Providence.

## SOUTH CAROLINA DIVISION.

C. F. Dill, Chief Warden, Greenville.

## SOUTH DAKOTA DIVISION.

D. C. Booth, Chief Warden, Spearfish; John C. Barber, Sec.-Treas., Lead.

## TENNESSEE DIVISION.

Hon. G. C. Martin, Chief Warden, Clarksville; Hon. Austin Peay, Jr., Sec.-Treas., Clarksville.

## TEXAS DIVISION.

Prof. S. W. Stanfield, Chief Warden, Weatherford; W. E. Heald, Sec.-Treas., San Angelo.

## UTAH DIVISION.

Hon. John Sharp, Chief Warden, Salt Lake City.

## VERMONT DIVISION.

W. E. Mack, Chief Warden, Woodstock; S. C. White, Sec.-Treas., Woodstock.

## VIRGINIA DIVISION.

R. G. Bickford, Chief Warden, Newport News. C. O. Saville, Vice Warden, Richmond; M. D. Hart, Sec.-Treas., 1217 East Main St., Richmond.

## WASHINGTON DIVISION.

F. S. Merrill, Chief Warden, Spokane; F. A. Pontius, Sec.-Treas., Seattle; Munro Wyckoff, Vice-Warden, Pt. Townsend,

## WEST VIRGINIA DIVISION.

E. F. Smith, Chief Warden, Hinton,

## WISCONSIN DIVISION.

Frank Kaufman, Chief Warden, Two Rivers; Dr. A. Gropper, Sec.-Treas., Milwaukee.

## WYOMING DIVISION.

H. E. Wadsworth, Chief Warden, Lander; Frank Bond, Sec.-Treas., Cheyenne.

*Applications for membership and orders for badges should be addressed to Arthur F. Rice, Secretary, 23 W. St., New York.*

## LOCAL WARDENS IN NEW YORK.

County.	Name of Warden.	Address.
New York,	Conrad L. Meyer,	46 W. Broadway.
Livingston	M. De La Vergne,	Lakeville.
"	K. S. Chamberlain,	Mt. Morris.
"	Henry Skinner,	Springwater.
"	Dr. J. W. Cowan,	Geneseo.
Albany,	C. D. Johnson,	Newtonville.
"	Kenneth E. Bender,	Albany.
Broome,	John Sullivan,	Sanitaria Springs
"	R. R. Mathewson,	Binghamton.
Cayuga,	H. M. Haskell,	Weedsport.
Chemung,	Fred Uhle,	Hendy Creek,
"	M. A. Baker,	Elmira.
Cortland,	James Edwards,	Cortland,
Erie,	E. P. Dorr,	103 D. S. Morgan Building, Buffalo.
"	Marvin H. Butler,	Morilla.
Essex,	W. H. Broughton,	Moriah.
Franklin,	Jas. Eccles,	St. Regis Falls.
Montgomery,	Charles W Scharf,	Canajoharie.
Oneida,	J. M. Scoville,	Clinton.
Orange,	Wilson Crans,	Middletown.
"	J. Hampton Kidd,	Newburgh.
"	Thomas Harris,	Port Jervis.
Richmond,	Lewis Morris,	Port Richmond.
St. Lawrence,	Dr. B. W. Severance,	Gouverneur.
"	A. N. Clark,	Sevey.
Schenectady,	J. W. Furnside,	Schenectady.
Suffolk,	F. J. Fellows,	Central Islip, L. I.
"	P. F. Tabor,	Orient, L. I.
Tioga,	Geo. Wood,	Owego.
Washington,	C. L. Allen,	Sandy Hill.
"	A. S. Temple,	Whitehall.
"	J. E. Barber,	Dresden.
Westchester,	George Poth,	Pleasantville.
"	Chas. Seacor,	57 Pelham Road, New Rochelle.
"	M. W. Smith,	Croton Falls.
"	Ralph Gorham,	Mt. Kisco
Dutchess,	A. B. Miller,	Jackson's Corners
Columbia,	James Lush,	Memphis.
Onondaga,	B. L. Wren,	Penn Yan.
Yates,	Symour Poiner,	Branch Port.
"	Chas. H. DeLong,	Pawling.
Dutchess,	Jacob Tompkins,	Billings.
Queens,	Gerard Van Nostrand,	Flushing, L. I.
"	W. S. Mygrant,	46 Elton Street, Brooklyn.
"	P. A. Geepel,	473 Grand Ave., Astoria, L. I.
"	L. B. Drowne,	119 Somers Street, Brooklyn.
Ulster,	M. A. DeVall,	The Corners.
"	Wm. S. Mead,	Woodstock.
Jefferson,	C. J. Smith,	Watertown.
Herkimer,	D. F. Sperry,	Old Forge.
Oswego,	J. E. Manning,	154 West Utica St.
Putnam,	H. L. Brady,	Mahopac Falls.
Schuyler,	G. C. Fordham,	Watkins.
Allegany,	G. A. Thomas,	Belvidere.
Schoharie,	O. E. Eigen,	Sharon Springs.
Warren,	Geo. McEchron,	Glen Falls.
Orleans,	J. H. Fearby,	E. Shelby.
Green,	W. J. Soper,	Windham.
Hamilton,	David Aird, Jr.,	Lake Pleasant.

## LOCAL WARDENS IN OHIO.

Stark,	A. Dangeleisen,	Massillon.
Franklin,	Brook L. Terry,	208 Woodward Av., Columbus.
Cuyahoga,	A. W. Hitch,	161 Osborn St., Cleveland.
Clark,	Fred C. Ross,	169 W. Main St., Springfield.
Erie,	David Sutton,	418 Jackson St., Sandusky.
Fulton,	L. C. Berry,	Swanton.

County.	Name of Warden.	Address.
Hamilton,	W. C. Rippey,	4465 Eastern Ave Cincinnati.
Allen,	S. W. Knisely,	Lima.
Knox,	Grant Phillips,	Mt. Vernon.
Lorain,	T. J. Bates,	Elyria.
Ottawa,	Frank B. Shirley,	Lakeside.
Muskingum,	Frank D. Abell,	Zanesville.
Scioto,	J. F. Kelley,	Portsmouth.
LOCAL WARDENS IN CONNECTICUT.		
Fairfield,	George B. Bliss,	2 Park Row, Stamford, Ct.
"	Harvey C. Went,	11 Park St., Bridgeport, Ct.
Fairfield,	Samuel Waklee,	Box 373, Stratford.
Litchfield,	Dr. H. L. Ross,	P. O. Box 100, Canaan, Ct.
Middlesex,	Sandford Brainerd,	Ivoryton.
New Haven,	Wilbur E. Beach,	318 Chapel Street, New Haven, Ct.
"	D. J. Ryan,	188 Elizabeth St., Derby.
LOCAL WARDENS IN MASSACHUSETTS.		
Norfolk,	Orlando McKenzie,	Norfolk.
"	J. J. Blick,	Wrentham.
"	S. W. Fuller,	East Milton.
Suffolk,	Capt. W. J. Stone,	4 Tremont Row, Boston.
Worcester,	B. H. Mosher,	Athol.
LOCAL WARDENS IN NEW JERSEY.		
Mercer,	Edw. Vanderbilt,	Dentzville, Trenton.
"	Roland Mitchell,	739 Centre St., Trenton
"	F. C. Wright,	Trenton.
Morris,	Joseph Peliet,	Pompton Plains
"	Chas. W. Blake,	Dover.
"	Francis E. Cook,	Butler.
"	Calone Orr,	Hibernia.
Somerset,	G. E. Morris,	Somerville.
Sussex,	Isaac D. Williams,	Branchville.
Union,	A. H. Miller,	Cranford.
"	C. M. Hawkins,	Roselle.
Warren,	{ Jacob Young,	{ Phillipsburg.
Monmouth,	{ Reuben Warner,	{ Wanaque.
Hudson,	Dory-Hunt,	51 Newark St., Hoboken
A. W. Letts,		
LOCAL WARDENS IN PENNSYLVANIA.		
Jefferson,	John Noll,	Sykesville.
Perry,	Samuel Sundry,	Lebo.
Warren,	F. P. Sweet,	Goodwill Hill.
"	Nelson Holmes,	Cornplanter.
Juniata,	Clifford Singer,	Oakland Mills.
"	Ezra Phillips,	McAlesterville.
Venango,	G. D. Benedict,	Pleasantville.
Potter,	Ira Murphy,	Coudersport.
"	Wiley Barrows,	Austin.
"	Chas. Barrows,	Austin.
Crawford,	Jasper Tillotson,	Tillotson.
"	Geo. T. Meyers,	Titusville.
"	J. B. Lamb,	Buel.
Cambria,	W. H. Lambert,	720 Coleman Ave. Johnstown.
Butler,	F. J. Forquer,	Murrinsville.
Allegheny,	S. H. Allen,	Natrona.
Beaver,	N. H. Covert,	Beaver Falls.
"	W. R. Keefer,	"
McKean,	C. A. Duke,	Duke Center.
"	L. P. Fessenden,	Granere.
"	Wm. Holsinger,	Stickney.
Lackawanna,	Wm. Weir,	Moosic.
"	Wm. Major,	"
Carbon,	Asa D. Hontz,	East Mauch Chunk.
Cumberland,	J. C. Gill,	Mechanicsburg.
Wyoming,	Cyrus Walter,	Tunkhannock.
Tioga,	E. B. Beaumont, Jr.,	Lawrenceville.
"	G. H. Simmons,	Westfield.
Lycoming,	Jas. J. Brennan,	Oval.
"	B. D. Kurtz,	Cammal.
Delaware,	Walter Lusson,	Ardmore.
Montgomery,	L. C. Parsons,	Academy.
Bradford,	Geo. B. Loop,	Sayre.
Clarion,	Isaac Keener,	New Bethlehem
Cameron,	Harry Hemphill,	Emporium.
Clinton,	M. C. Kepler,	Renovo.
"	Geo. L. Kepler,	Renovo.
Northumber-	{ G. W. Roher,	{ 505 Anthracite St., Shamokin
land,	{	{
Elk,	D. R. Lobaugh,	Ridgway.
Fayette,	Ely Cope,	Cadwallader.

LOCAL WARDENS IN MICHIGAN.

County.	Name of Warden.	Address.
Ottawa,	W. H. Dunham,	Drenthe.
Kalamazoo,	C. E. Miller,	Augusta.
Berrien,	W. A. Palmer,	Buchanan.
Cass,	Thomas Dewey,	Dowagiac.
Hillsdale,	C. A. Stone,	Hillsdale.
Lake,	John Trieber,	Peacock.

LOCAL WARDENS IN VIRGINIA.

Mecklenburg,	J. H. Ogburn,	South Hill.
King William,	N. H. Montague,	Palls.
Smythe,	J. M. Hughes,	Chatham Hill.
King & Queen,	R. D. Bates,	Newtown.
Louisa,	J. P. Harris,	Applegrove.
Henrico,	W. J. Lynham,	412 W. Marshall.
Richmond,		Richmond.
Harrisonburg,		Harrisonburg.

LOCAL WARDENS IN WYOMING.

Fremont,	Nelson Yarnall,	Dubois.
Uinta,	{ S. N. Leek,	{ Jackson.
	{ F. L. Peterson,	{
Carbon,	Kirk Dyer,	Medicine Bow.
Laramie,	Martin Breither,	Cheyenne.

LOCAL WARDENS IN TENNESSEE.

Sumner,	W. G. Harris,	Gallatin.
Stewart,	John H. Lory,	Bear Spring.
Robertson,	C. C. Bell,	Springfield.
Montgomery,	P. W. Humphrey,	Clarksville.
Madison,	H. T. Rushing,	Jackson.

LOCAL WARDENS IN NEBRASKA.

Hall,	E. C. Statler,	Grand Island
-------	----------------	--------------

LOCAL WARDENS IN NEW HAMPSHIRE.

Cheshire,	S. C. Ellis,	Keene.
Sullivan,	G. A. Blake,	Lempster.
	J. W. Davidson,	Charlestown.

LOCAL WARDENS IN VERMONT.

Rutland,	Wm. J. Liddle,	Box 281, Fair Haven
Windsor,	F. A. Tarbell,	West Bridgewater.
Orleans,	E. G. Moulton,	Derby Line.
Essex,	H. S. Lund,	Granby.

LOCAL WARDENS IN ILLINOIS.

Rock Island,	D. M. Slottard,	12th Ave and 17th St., Moline.
Iroquois,	J. L. Peacock,	Sheldon.

LOCAL WARDENS IN OKLAHOMA.

Kiowa and Comanche Nation,	A. C. Cooper,	Ft. Sil.
----------------------------	---------------	----------

LOCAL WARDENS IN IOWA.

Clinton,	D. L. Pascol,	Grand Mound.
Pottawattamie,	Dr. C. Engel,	Crecent.

LOCAL WARDENS IN WASHINGTON.

Okanogan,	James West,	Methow.
Stevens Co.,	Jacob Martin,	Newport.

LOCAL WARDENS IN UTAH.

Washington,	S. C. Goddard,	New Harmony.
	J. A. Thornton,	Pinto.

LOCAL WARDENS IN KANSAS.

Ness,	Frank Lake,	Ransom.
-------	-------------	---------

LOCAL CHAPTERS.

Albert Lea, Minn.,	H. A. Morgan,	Rear Warden
Angelica, N. Y.,	C. A. Lathrop,	"
Augusta, Mont.,	H. Sherman,	"
Austin, Minn.,	G. F. Baird,	"
Austin, Pa.,	W. S. Warner,	"
Boston, Mass.,	Capt. W. I. Stone,	"
Buffalo, N. Y.,	H. C. Gardiner,	"
Cammal, Pa.,	B. A. Ovenshire,	"
Champaign Co., O.	Hy. F. MacCracken	"
	Urbana,	"
Charlestown, N. H.,	W. M. Buswell,	"
Cheyenne, Wyo.,	J. Hennessy,	"
Choteau, Mont.,	G. A. Gorham,	"
Cincinnati, Ohio,	B. W. Morris,	"
Coudersport, Pa.,	I. L. Murphy,	"
Cresco, Iowa,	J. L. Platt,	"
Davis, W. Va.,	J. Heltzen,	"
Dowagiac, Mich.,	W. F. Hoyt,	"
East Mauch Chunk, Pa.,	E. F. Pry,	"
Evansville, Ind.,	F. M. Gilbert,	"
Fontanet, Ind.,	W. H. Perry,	"
Ft. Wayne, Ind.,	W. L. Walthemarth	"
Great Falls, Mont.,	J. M. Gaunt,	"
Heron Lake, Minn.,	K. C. Buckeye,	"
Hollidaysb'g, Pa.,	T. J. Hemphill	"
Hopkinsville, Ky.,	Hunter Wood,	"
Indianapolis, Ind.,	Joseph E. Bell,	"
Jerome, Ariz.,	Dr. L. A. Hawkins,	"
Johnsonburg, Pa.,	W. J. Stebbins,	"
Kalispell, Mont.,	John Eakright,	"
Keene, N. H.,	F. P. Beedle,	"

Kingfisher, Okla.,	A. C. Ambrose,	Rear Warden.
Lake Co., Ind.,	Dr. R. C. Mackey,	"
Lawton, O. T.,	Marion Miller,	"
Lincoln, Neb.,	A. J. Sawyer	"
Logansport, Ind.,	E. B. McConnell,	"
Ludington, Mich.,	G. K. Cartier,	"
Mechanicsburg, Pa.,	Dr. J. H. Swartz,	"
Minturn, Colo.,	A. B. Walter,	"
Morgantown, W. Va.,	B. S. White,	"
New Albany, Ind.,	Dr. J. F. Weathers,	"
New Bethlehem, Pa.,	Isaac Keener,	"
Oklahoma City O. T.,	N. F. Gates,	"
Penn Yan, N. Y.,	Dr. H. R. Phillips,	"
Phillips, Wis.,	F. K. Randall,	"
Princeton, Ind.,	H. A. Yeager,	"
Reynoldsville, Pa.,	C. F. Hoffman,	"
Ridgway, Pa.,	T. J. Maxwell,	"
Rochester, N. H.,	Gustave Andreas,	"
" N. Y.,	C. H. McChesney	"
St. Paul, Minn.,	O. T. Denry,	"
St. Thomas, Ont.,	L. J. Hall,	"
Schenectady, N. Y.,	J. W. Furnside,	"
Seattle, Wash.,	M. Kelly,	"
Syracuse, N. Y.,	C. C. Truesdell,	"
Terre Haute, Ind.,	C. F. Thiede,	"
The Dalles, Ore.,	C. B. Cushing,	"
Walden, N. Y.,	J. W. Reid,	"
Wichita, Kas.,	Gerald Volk,	"
Winona, Minn.,	C. M. Morse,	"

DISCOUNTS TO LEAGUE MEMBERS.

The following firms have agreed to give members of the L. A. S. a discount of 2 per cent. to 10 per cent. on all goods bought of them. In ordering please give L. A. S. number:

- Syracuse Arms Co., Syracuse, N. Y. Guns.
- Davenport Fire Arms Co., Norwich, Conn. Shot guns, rifles.
- Gundlach Optical Co., Rochester, N. Y. Photographic goods.
- Blair Camera Co., Rochester, N. Y. Photographic goods.
- James Acheson, Talbot St., St. Thomas, Ontario, Sporting goods.

LIFE MEMBERS OF THE LEAGUE.

- W. D. Ellis, 136 W. 72d street, New York City.
- A. F. Rice, 155 Pennington avenue, Passaic, N. J.
- Dr. W. A. Valentine, 5 W. 35th street, New York City.
- A. A. Anderson, 6 E. 38th street, New York City.
- A. V. Fraser, 478 Greenwich street, New York City.
- E. S. Towne, care National Blank Book Co., Holyoke, Mass.
- F. G. Miller, 108 Clinton street, Defiance, Ohio.
- Gen. J. F. Pierson, 20 W. 52d street, New York City.
- E. T. Seton, 80 W. 40th street, New York City.
- J. H. Seymour, 35 Wall street, New York City.
- A. G. Nesbitt, Maple street, Kingston, Pa.
- D. C. Beard, 204 Amity street, Flushing, L. I.
- C. H. Ferry, 1720 Old Colony Bldg., Chicago, Ill.
- Hon. Levi P. Morton, 681 5th avenue, New York City.
- H. Williams, P. O. Box 156, Butte, Mont
- D. B. Fearing, Newport, R. I.
- E. H. Dickinson, Moosehead Lake Me.
- Lorenzo Blackstone, Norwich, Conn.
- A. L. Prescott, 90 W. Broadway, New York City.
- G. S. Edgell, 192 Broadway, New York City.
- W. B. Mershon, Saginaw, Mich.
- Hon. H. W. Carey, East Lake, Mich.
- George Carnegie, Fernandina, Fla.
- Andrew Carnegie, 2nd, Fernandina, Fla.
- Morris Carnegie, Fernandina, Fla.
- W. L. Underwood, 52 Fulton street, Boston, Mass.
- C. E. Butler, Jerome, Ariz.
- Mansfield Ferry, 183 Lincoln Park, Boulevard, Chicago, Ill.
- Austin Corbin, 192 Broadway, New York City.
- J. Stanford Brown, 489 Fifth Ave., New York City.
- W. H. Smith, Bryn Mawr, Pa.
- E. B. Smith, Bourse Bldg., Philadelphia, Pa.
- A. J. McClure, 158 State street, Albany, N. Y.
- Walter Thompson, Times Bldg., New York City.
- Clinton Gilbert, 2 Wall St., New York City.
- E. J. Hudson, 33 East 35th St., Bayonne, N. J.

There are thousands of men in the United States who should be life members. Why don't they join? Will someone please take a club and waken them?

# FORESTRY.

EDITED BY DR. B. E. FERNOW,

Director of the New York School of Forestry, Cornell University, assisted by Dr. John C. Gifford of the same institution.

It takes 30 years to grow a tree and 30 minutes to cut it down and destroy it.

## PRACTICAL FORESTRY.

Forestry is a word that is becoming familiar to nearly every reader of newspapers or magazines, but probably few people stop to consider its real meaning. It is a subject claiming more and more the attention of scientists, sought and studied in our colleges, and ranking as a profession with that of the lawyer, physician and other of the higher orders.

There is nothing new in the forests themselves, but the treatment of them is opening a new avenue of employment for hundreds. Neither is it to be a work wholly of a scientific nature. It bristles with practical requirements at every point.

From Mother Earth to the mill, or to that handsome piece of parlor furniture or delicately tinted writing paper, bearing the water mark of "linen" but perhaps only a few brief days made from the forests, may be termed a branch of forestry.

To forestry our land owners are giving an increasing interest, studying how best to grow, preserve and continue the vast forests of Maine. Only a few years ago the man who advanced the idea of forestry was the laughing stock of the old woodsman, who allowed "there would be wood enough as long as man existed." Those were the days before the great vats and grinders of the ever increasing pulp mills had commenced to devour the forests to an extent that sent out a warning of alarm.

Soil which is adapted to the growth of spruce may be as profitable to its owner or his heirs as that which is wholly suited or particularly chosen for its crop-bearing qualities. Rich indeed is the owner of soil suited to the growth of both crops and trees. Land that is non-agricultural, on account of being hilly or rocky, often is the best soil for the growth of spruce, and on it trees will grow to merchantable size in 40 to 50 years. By merchantable size is meant a tree having a diameter of 12 to 15 inches breast high. The yield is estimated to be 1,000 to 20,000 feet an acre.

A forest should be crowded when young to promote upward growth, as a tree that stands alone grows too much to branches and does not yield good timber. Much care should be taken in the cutting of our forests; only that timber which is sizeable and merchantable should be removed. The

smaller should be left to grow, thereby solving the problem of preserving the forests, but still handling them to a profit. Only the average growth should be removed from a tract each year.

It has been ascertained that the average annual growth of the State forests of Saxony, which are nearly all non-agricultural land, is 225 feet an acre, board measure. There are 432,300 acres of such forest; therefore the total annual growth of the whole forest is 97,200,000 feet, which quantity of timber can annually be cut without impairing the forests. The forest properly treated increases rather than diminishes in value. Saxony, which takes the lead in forestry, derives a net annual revenue of \$4.50 an acre from her State forests. France, from 2,100,000 acres of productive forest, derives a net annual revenue of \$1.91 an acre. Prussia, from 6,000,000 acres of State forests, has a net annual revenue of \$1.50 an acre. The aggregate of the State forests of Germany is 10,000,000 acres, from which is derived an annual net profit of \$23,000,000. The forests of Germany support 3,000,000 people.

Prof. Chas. S. Sargent, of the United States government, says in his report on the forest trees of North America: "The condition of the forests of Maine is interesting. They show that forest preservation is perfectly practicable in the Atlantic region, at least when the importance of the forest to the community is permanent. The existence of the State depends on the maintenance of the forest. The great forests of pine can not be restored, but the preservation of the few remnants of these forests is not impossible. The forests of Maine, once considered practically exhausted, still yield largely and continuously, and the public sentiment which has made possible their protection is the one hopeful symptom in the whole country that a change of feeling in regard to forest property is gradually taking place. The experience of Maine shows that where climatic conditions are favorable to forest growth, the remnants of the original forest can be preserved and new forests created, as soon as the entire community finds forest protection essential to its material prosperity."

While practically a new work, considerable progress is being made in forestry in

the United States. Legislative recognition has been given forestry in 18 States, but the work has been abandoned in 3, leaving 15 in which the work is being carried on at present, as follows: Maine, Connecticut, Kansas, Maryland, Michigan, Minnesota, New Hampshire, New Jersey, New York, North Carolina, North Dakota, Oregon, Pennsylvania, West Virginia and Wisconsin. Over \$250,000 is now annually appropriated by Congress for forestry purposes. A career for young American foresters is opening, and there are several schools where scientific education and practice in forestry can be acquired. Positions in the United States bureau of forestry opened to trained foresters are those of field assistant. These positions carry a salary of \$720 to \$1,000 a year in the beginning, with the payment of all living and traveling expenses incident to field work. Field assistants generally spend about 6 months in the field and the remainder of the time in the preparation of the reports in Washington. Individual corporations and pulp concerns are taking a greater interest in forestry from year to year, realizing that in such work lies the success of their business. Such concerns as the International and Great Northern are putting in much work along the line of forestry.

A branch of forestry that is being given more attention than formerly is that of tree planting. Forest planting in Maine should be practically confined to the land that, by nature of its roughness or sterility, is unfit for agricultural purposes. Hilly and stony lands are usually fit only for the production of timber, and should be kept constantly forested. As long as lumber was cheap and plentiful, no progress could be made in such planting, but now that it is becoming profitable to grow timber, the otherwise worthless land has begun to receive attention. Many a worn out farm may be restored to fertility by growing forest trees on it for a series of years, and many Maine farms are better suited for the production of timber than for any other purpose.

In his message to Congress, President Roosevelt said: "Public opinion throughout the United States has moved steadily for a just appreciation of the value of forests, whether planted or of natural growth. The great part played by them in the creation and maintenance of the national wealth is now more fully realized than ever before. Wise forest protection does not mean the withdrawal of forest resources, whether of wood, water, or grass, from contributing their full share to the welfare of the people, but, on the contrary, gives the assurance of larger and more certain supplies. The fundamental idea of

forestry is the perpetuation of forests by use. Forest production is not an end of itself; it is a means to increase and sustain the resources of our country and the industries which depend on them. The preservation of our forests is an imperative business necessity. We have come to see clearly that whatever destroys the forest, except to make way for agriculture, threatens our well being."

As an investment forestry is more and more playing a part in the commercial world. The capitalist of to-day is looking for a safe place in which to invest his income, and the purchase of timber lands is fast becoming one of the popular investments which is considered safe and sure. Not many years ago lumber values were such that private persons making a business of lumbering could not afford to do the expensive logging necessary to preserve the forests. To cut only trees about 12 or 15 inches in diameter involves a considerable added expense over cleaning the ground as they go, and to clean the ground of tops and other inflammable debris is still another expense which would put a business so conducted almost out of competition with that of the ordinary sort. Lumber is now high enough, however, so that if the lumbermen will be content with a nominally lighter annual profit they can make preservative lumbering pay and feel that, whatever the sacrifice, it will be more than compensated for by the increase in the value of the capital remaining in the timber.—Report of E. E. Ring, Forest Commissioner of Maine.

#### WOOD LOTS.

In a recent paper entitled "The Use and Care of the Farm Wood Lot," Charles A. Davis, instructor in forestry at the University of Michigan, called attention to the following points:

Every farm should have a well established wood lot, from which firewood, posts, poles and other small timber used on a farm may be taken as needed. The wood lot may be on a hill too steep for cultivation, or any other place which may not be suitable for the ordinary purposes of agriculture; and it may be so located as to form a windbreak.

After a wood lot has been established it must be kept in good condition. Not infrequently a farmer will so neglect his wood lot or so misuse it as to cause it to deteriorate rapidly. Such deterioration is often due to excessive thinning, to pasturing or to constant removal of the better timber and the leaving of the poorer trees. Correct use would exclude cattle and sheep entirely. The undergrowth should be left to form a soil cover, which adds to the moisture-receiving capacity; or young

trees should be planted which will grow in the shade and eventually replace the old growth. Maple, beech, box elder, ash and many other species are useful for this purpose. In removing trees only the poorest timber which can be used for the desired purpose should be taken. This is contrary to the general practice in which tall, straight and vigorous timber is often cut down for firewood when the less thrifty, crooked or branchy trees would serve just as well.

The wood lot should be fenced up to its border. If a margin of grass land is allowed between the border of the wood and the fence, the temptation to use the whole for pasturage may prove too great.

If undesirable kinds of trees are present, more desirable kinds should be planted, and as soon as these have been established the others may be removed. It should, however, always be remembered that for firewood poor soft woods often yield in the aggregate a greater profit than the slower growing hard woods. Thus poplars and willows will pay much better in a given time than the more valuable hickories and hard maples.

Some species of trees will produce marketable material, such as poles and posts, in 15 to 25 years, while timber of large dimensions will take 40 to 100 years to grow.

#### METHODS OF FIGHTING FIRE.

The best method of fighting fire depends on the location and conditions. The chief requirement is to fight, by some method, and to commence as soon as possible after a fire is discovered. Often a fire which could have been stopped with little exertion at first, results in heavy losses as it spreads almost beyond control.

A favorite and usually successful method of fighting fires is by trenching around them. A trench 2 or 3 feet deep should be dug, care being taken to remove all the old roots and twigs to stop the progress of the fire in the ground. Then with plenty of help the fire can usually be checked by the time it has burned to the trenches.

Where water is near, good service can be done by a bucket brigade. Surface fires can be checked, if not of too much volume, by beating them out with green branches. Dirt or sand thrown on fire is one of the best means of putting it out. Setting back fires is another way of stopping destructive fires. The back fire must be allowed to burn only against the wind and toward the main fire, so that when the 2 fires meet they must both go out for lack of fuel. To prevent back fires from moving with the wind, they should be started on the windward side of a road, or clearing, or some line which they can be kept from

crossing. Back fires are sometimes driven beyond control by a change of wind, but the chief danger from their use is lighting them at the wrong time or in the wrong place. Still, there is no other means of fighting fire so powerful, and none so effective when rightly used. Fire lines, strips kept free from inflammable material, are useful in checking small fires and of great value as lines of defense in fighting large ones.—Exchange.

#### FOREST EXHAUSTION IN SIGHT.

We may as well realize that our efforts to secure a more rational treatment of our forest resources and apply forestry in their management are not too early, but rather too late; that they are by no means sufficient; that serious trouble and inconvenience are in store for us in the not too distant future; that the blind indifference and the dallying or amateurish playing with the problem by Legislatures and officials is fatal.

We can summarize the situation, which justifies the urgent need of the foresters' art in the United States, from the point of view of supplies, as follows:

The consumption of forest supplies, larger than in any other country in the world, promises not only to increase with the natural increase of the population, but in excess of this increase per capita, similar to that of other civilized industrial nations, annually at a rate of not less than 3 to 5 per cent.

The most sanguine estimate of timber standing predicates an exhaustion of supplies in less than 30 years if this rate of consumption continues, and of the most important coniferous supplies in a much shorter time.

The conditions for continued imports from our neighbor, Canada, practically the only country having accessible supplies such as we need, are not reassuring, and may not be expected to lengthen the natural supplies appreciably.

The reproduction of new supplies on the existing forest area could under proper management be made to supply the legitimate requirements for a long time; but fires destroy the young growth over large areas, and where production is allowed to develop, in the mixed forest at least, owing to culling processes which remove the valuable kinds and leave the weed trees, these latter reproduce in preference.

The attempts at systematic silviculture, that is, the growing of new crops, are, so far, infinitesimal, compared with the needs.

B. E. Fernow, in the *Forestry Quarterly*.

#### FOREST EXPERIMENT STATION.

The Bureau of Forestry of the United States Department of Agriculture has established a permanent forest experiment station at the University of California. Dr. W. K. Hatt, recently called from the chair of applied science in Purdue University to serve as civil engineer in the Bureau of Forestry, has gone from Washington to organize the station. The resources of the civil engineering laboratory of the university have been placed at his disposal. A civil engineer who will go from Washington to take charge of the work, and his student assistants, will be continuously engaged hereafter in commercial and scientific investigations as to California woods. San Francisco lumber dealers have offered to supply all the timber needed. Laboratory investigations will be conducted as to the strength of various California timbers, the effects on timbers of wet and dry weather, of heat and cold, elasticity and durability, preservative methods, ways of seasoning, and the like. The results secured at this station will be made available for general use by publication as bulletins of the Bureau of Forestry.—*Forestry and Irrigation*.



## PURE AND IMPURE FOODS.

*"What a Man Eats He Is."*

Edited by C. F. LANGWORTHY, PH.D.

Author of "On Citraconic, Itaconic and Mesaconic Acids," "Fish as Food," etc.

### CHEESE IN SMALL SIZES.

As chemical analysis and the experience of users show, cheese is one of the most wholesome and nutritious foods. Cheddar, full cream, Swiss and similar kinds of cheese contain on an average 33 per cent. water, 27 per cent protein, 34 per cent. fat, 2 per cent. carbohydrates and 4 per cent. ash, the fuel value being about 2,000 calories a pound. Such cheese as cottage and Neufchatel, which are made from sour milk, are eaten fresh and moist. They contain some 60 per cent. water. The protein content is not far from 20 per cent. and the carbohydrate and ash content are much the same as in the sorts mentioned. If made of skim milk, the fat content is low, averaging about one per cent. If the cream is included, the fat content is about the same as in other cheese. Depending on whether cream is or is not present, the fuel value ranges from 500 to 1,500 calories a pound.

It will be seen that cheese, especially such sorts as Cheddar, full cream, etc., contains large percentages of protein and fat, together with small quantities of carbohydrates and ash. In other words, cheese supplies fairly large quantities of both nitrogenous material and energy in proportion to its bulk. Notwithstanding its high food value, cheese is apparently eaten much less in this country than in some regions of Europe. According to statistics gathered by the Storrs Connecticut Agricultural Experiment Station, cheese furnishes only 0.4 per cent. of the total food, 1.6 per cent. of the total protein and 1.6 per cent. of the total fat in the average American diet. The cheese most commonly eaten is like the English cheddar, and is known by that name or as factory cheese. The thoroughness with which this kind of cheese is digested by man was recently studied by H. Snyder at the Minnesota Station. He found that when a fairly large quantity was eaten with a ration of bread and milk, 93 per cent. of the protein and 95 per cent. of the fat of the cheese were digested, the available energy being 93 per cent. Artificial digestion experiments showed that the pancreas ferment had much more effect on cheese than the peptic, indicating that it is digested in the intestines rather than in the stomach. According to Professor Snyder, "this is probably the reason why cheese is characterized as a hearty food, and frequently causes digestive troubles when eaten. In such cases the quantity of cheese

consumed should be reduced to correspond with the digestive capacity of the individual."

In order to promote the manufacture of various kinds of cheese in this country, it is desirable to encourage greater consumption and thus increase the demand. Many believe that marketing cheese in more convenient and attractive forms would increase the consumption of this valuable food product. More attention is given to this matter in the case of butter than in the case of cheese. Some of the higher priced sorts are marketed in small packages and jars, but the bulk of the cheese consumed is still undoubtedly marketed in large sizes, which are cut into slices and sold by the pound. Such slices do not keep well, since the freshly cut surface exposed to the air is large in proportion to the weight. E. H. Farrington, of the Wisconsin Station, has reported the results of experiments on the manufacture of cheese in small sizes, the form chosen being suggested by the pound prints of butter which have proved so successful. The cheddar cheese experimented with was made by the usual process, the only modification being in the pressing. The curd was placed in a mold, or hoop, of rectangular shape, the bottom or "follower" of which was a carved board divided into a number of sections, each of which corresponded to a half-pound print of cheese. Two sections would, of course, represent a pound. The form of the prints is determined by the carving of the board, which may be of any size or design to suit any particular market. The sections can be readily cut apart when sold by the retailer. In the experiments at the University of Wisconsin the letters U W were stamped on each section of cheese. The thickness of the block of cheese is, of course, regulated by the quantity of curd put into the mold each time. The Wisconsin blocks of cheese averaged nearly 15 pounds in weight and were each divided into 15 prints. The dimensions of each block of cheese were 11.5 by 13.25 by 2.5 inches, each print being 2.5 by 4.25 inches.

No difficulty was experienced in curing the cheeses in the same ways as are followed with cheddar. The bottom and sides should be greased and the cheese turned occasionally, although it should not rest on the printed surface a long time. By exercising a little care in handling these

cheeses during the curing process, according to Professor Farrington, they can be kept clean and attractive in appearance, and if well made from good milk will develop an acceptable flavor that, together with the trade-mark branded into each pound, will be helpful in protecting the reputation of any given make of cheese.

#### FRENCH PATE DE FOIS GRAS.

The statement has been made that in the high priced French *paté de foie gras* exported to the United States "the traditional diseased livers have been replaced by beef and pork." Discussing these subjects, the American Consul at Bordeaux, Albion W. Tourgée, says:

"It is hardly correct, at the outset, to refer to *foie gras*, as it is produced in Southern France, at least, as diseased. A fatted goose liver is no more diseased than the meat of an overfed hog. Both are abnormal and in that sense might be regarded as the product of unsanitary conditions. The goose may for a time be confined by a tether a yard or so in length, fastened to a stake, beside which it waits with the healthiest appetite for its frequently supplied portion of American corn meal, which is the food chiefly relied on for fattening. In fact, the increased importation of American maize during the past quarter of a century has been a chief stimulus to the trade in *foie gras*. The goose is not encouraged to take too much exercise, any more than any other fattening animal. It is not fed for its health, but to incline it to take on fat. The result of this is to greatly enlarge the liver, which is the most valuable part of the carcass. Those who have seen the prize hog, almost unable to stand erect, and kept from actual melting of its superabundant flesh only by frequent use of the hose, will readily perceive that if too much fat is a disease there are other forms of abnormal development just as objectionable as the much prized goose liver.

"*Foie gras d'oie*, the fat goose liver, is prepared for use and export here in several forms: *Foie gras naturel*; *patés de foie gras*; and *purée de foie gras*. The *foie gras naturel* is simply the cooked liver served without any form of sauce or seasoning except the fat or oil of the liver itself. The *paté de foie gras* of commerce consists of the cooked liver packed in tin boxes of a standard size, which the liver is roughly cut to fit. The space not occupied by the liver is filled with the trimmings of the liver or with pork, finely hashed and pressed in. Over this is poured the melted fat, sometimes of the liver and sometimes beef suet. The pieces of liver clipped off in this process of fitting the cooked liver to the box are used with other hashed

meats and flavoring matters like truffles in preparing what is known in commerce as *purée de foie gras*.

"The practice of using suet instead of the natural fat of the goose liver, as a support or matrix by which the interstices between the liver and the box are filled, is not so wholly reprehensible as might at first appear, since it has certain good reasons, or at least excuses. In the first place, the suet and the somewhat firmer meat packed about the liver prevent the latter from being broken by sliding about in the box, as it is likely to do on long journeys when only the thin oil of the liver is used. Another fact which shippers have learned by costly experience is that the pure fat of the goose is much more likely than beef suet to become rancid when used as the sole pack of the *foie*. It is also claimed that the strong greenish fat of the goose is sometimes repulsive to persons of weak stomach; and that Americans, who are especially opposed to what they term 'messy dishes,' are unreasonably opposed to *patés* made with the pure goose fat. The modifications described are prepared simply to reconcile the perverted American taste to the foreign dainty. Though the primal purpose of the change of material was no doubt to reduce the cost of production, the result is said not only to be a reduction in price to the consumer, but to give him an opportunity to select the form of this delicacy he may prefer. Some people greatly prefer the sorts which have the *foie naturel* with the supporting *paté* made of other hashed meats and the more wholesome appearing and less highly flavored suet.

"Instead of being a harmful or depreciable adulteration of a well known product, it is claimed this is a modification not only harmless, but of a character essential to its preservation and adaptation to the popular taste of the majority of the American people. At all events, it does not seem exactly fair that firms which have made entirely healthful products should be rated by name among those engaged in making and selling adulterated food. At least one well known shipper manufactures all kinds of *foie gras* known to commerce, leaving to his customers the choice of those best suited to their particular trade. All are good and all their components absolutely wholesome, as he declares, some being better adapted for one taste and some for others."

"I can not eat them," said the belle, looking nervously at the dainty entrée of frogs' legs.

"Why not? They're all right."

"Oh, they look like breaded chorus girls."

## BOOK NOTICES.

### THE CARIBOU.

The 7th Annual Report of the New York Zoological Society contains an interesting and important paper by Mr. Madison Grant, Secretary of the Society, on the caribou species of North America.

In view of the recent discoveries in North-western North America, and elsewhere, of a new species of caribou, Mr. Grant's paper is timely and valuable. Without entering on technical descriptions of the characters of the various species that have been described up to date, the author sets forth clearly and distinctly the 2 great groups of caribou, the barren ground and the woodland; and by means of an admirable map illustrates the areas occupied by each and the type locality of each species thus far described. Eastward of the dividing line between Alberta and Assiniboia, the woodland caribou does not range North of the 59th parallel. Westward of that region, however, the mountain caribou, Osborn's caribou, and possibly others, range from Northern Idaho Northwestward, nearly to the Copper river, Alaska. On the Kenai peninsula occurs Stone's caribou, and on the Alaska peninsula, Grant's caribou, both of which belong to the barren ground group. The latest accession to the ranks of caribou species is Peary's caribou, from Ellsmere Land.

The number of species accredited to the barren ground group are 5, and to the woodland 4; but the author does not vouch for the permanency of all these forms.

The illustrations contained in this paper constitute a feature of great interest. The 10 plates of full length figures show some exceptionally choice subjects; while the 20 plates which illustrate the antlers of 8 species constitute a collection which every naturalist and sportsman will value.

In dealing with the caribou of North America, as a whole, Mr. Grant handles his subject with commendable judgment and breadth of view. He is careful to avoid conclusions that are not based on grounds absolutely unassailable, but wisely leaves to the future the determination of certain vexed questions which can not be settled until much more material has been secured and made available.

It is difficult to say too much in praise of such papers as this, popular in form, but scientifically exact, and replete with just such information as every lover of wild animal life will appreciate and value.

Copies of "The Caribou," bound as a separate pamphlet, can be obtained of the New York Zoological Society, No. 11 Wall

street, New York city, at 40 cents each. None are available for gratuitous distribution.

### LEARN THE PLANTS.

"Our Northern Shrubs" is the title of a book written by Harriet L. Keeler, and published by Charles Scribner's Sons, New York. It is planned on the same lines as "Native Trees," which is also the work of Miss Keeler. The purpose of the present volume is to supply a complete guide to the shrubs of the Northern States, by the aid of which any one of them may be identified, and its habits learned. Nearly all the shrubs which grow in this region are illustrated in this book, either from photographs or from careful and accurate pen-drawings. The photographic reproductions are especially clear, and the reader may identify many a shrub by a simple glance at one of these pictures without looking at the caption. Most of the subjects are shown in bloom, and some of them in the seed or fruit stage as well. The descriptions are of popular nature, so they may be readily understood by the amateur nature lover as well as by the trained botanist.

Every man, woman and child who frequents the woods or the fields should have a copy of this book. It sells at \$2 net and may be had through any book dealer.

Among the most delightful of the summer novelettes is "The Fighting Chance," by Gertrude Lynch. This story first appeared in *The Smart Set*, a year ago, and the publishers have thought it worthy of reproduction in book form. It is the story of a beautiful and unscrupulous girl who is intent on marriage and has 3 days in which to attain it. Miss Lynch's style is witty and epigrammatic, and the story flows lightly and gracefully to its conclusion, leaving the reader indisposed to quarrel with the outcome. Miss Lynch's interest is chiefly psychological and her point of view satirical. Her men and women flit easily through the realms of young love, holy matrimony and divorce, without unseemly evidence of emotion, and make charmingly attractive summer companions in a far too vigorous world. "The Fighting Chance" is published by the *Smart Set Publishing Co.*, New York and London.

"Florida Fancies," by F. R. Swift, is a most attractive and charmingly illustrated account of a 6 months' cruise through Florida waters in a naphtha launch. Mr. Swift is a thorough sportsman and has a

keen sense of humor. From New York, up the wild, weird windings of the Ocklawah river and out into Gum swamp, there is not a dull page in the book. Shooting ducks, geese, snipe, and quails; hunting deer; fishing; and spearing alligators make lively work, of which Mr. Swift writes delightfully.

"Jack Stanley, a Romance of the Cuban War," is a second story in the book; a tragic love story which will strike a sympathetic chord in many a heart.

"Florida Fancies" is published by G. P. Putnam's Sons, New York and London.

H. W. Kerr, of Little Sioux, Ia., has written a book entitled "Quailology," which deals exhaustively with the question of domesticating and propagating the quail. It treats not only of Bob White, but of the entire quail family as represented in America, and with at least 2 European species. The pamphlet is handsomely illustrated with photographs, several of them from live birds, and others from mounted specimens. Some of these photographs are printed in tinted inks and all on heavy coated paper, so that the best possible results are secured.

The book sells at \$1 a copy and can be had by addressing the author as above.

"People of the Whirlpool" is a story concerning phases of social life in Manhattan as seen by the eyes of a provincial and contrasted with the sweetly domestic country life which the writer represents as her own. The name of the author is withheld, which is an inexpensive way of advertising a former book by the same. The present volume exploits the humble virtues, now so fashionable, of which, however, the provincial family seem to have a somewhat fatiguing monopoly.

Published by the Macmillan Company, New York and London; price \$1.50.

"The Witchery of Sleep," compiled by Mr. Willard Moyer, is a new and delightful book on the subject of sleep and its relation to human life, together with its moods, its mysteries, its sentiment, and all its accessories thereto. It is in royal octavo, 225 pages, profusely illustrated with line engravings and 40 inserts in 2 colors, antique deckle edges, gilt tops, old English style, bound in art cloth and stamped in gold and color. The price is \$2, and the book is for sale by all booksellers, or sent postpaid on receipt of price by the publishers, Ostermoor & Company, 114 Elizabeth street, New York.

Hon. W. F. Scott, Fish and Game Warden of Montana, has printed the game laws of that State in a neat little pamphlet

of convenient size for carrying in one's pocket. It would be well for every sportsman in that State, or who intends to hunt in that State at any time, to have a copy of these laws for reference, and same can be had, free of charge, by writing Mr. Scott at Helena.

"Man Overboard" is a short story by Marion Crawford, which deals with the supernatural. In his usual virile and effective way Mr. Crawford mingles the salt breezes of the sea with chill, hair-lifting draughts that come no one may say whence. The story is not important but will make good summer reading. Published by The Macmillan Co., New York and London; price 50 cents.

"Methods of Estimating and Measuring Standing Timber," by A. Knechtel, B.S., F.E., has been issued in pamphlet form as a reprint from the 6th Annual Report of the Forest, Fish and Game Commission of the State of New York. This is the best if not the only publication devoted entirely to this subject which has yet appeared in the English language.

Why do you not publish RECREATION twice a month, and put the price up to \$2? It's a long time to keep a man waiting, a whole month. When I get mine, they can not get me to my meals until I have looked it over. There and then I fill my old pipe and get my easy chair by the fire, and am lost to the world until I have given it a good overhauling.

A. F. Chase, Dorchester, Mass.

"Do you call yourself a poet or a versifier?"

"Well, when the editor uses one of my effusions to light his pipe with I suppose it's a case of verse afire."—Philadelphia Record.

I have been a reader and admirer of your magazine for some time. Am particularly pleased with the articles in regard to the porkers who do not know how to stop when they have enough.

H. H. Humphrey, Sisseton, S. D.

There was once in Kentucky a colonel  
Who a jug kept for jaggng noctolonel.  
When one night his fair daughter  
Plugged the jug chuck with waughter,  
He kicked up a row most infolonel.

RECREATION is the best publication of its kind I ever saw.

Chas. A. Lindstedt, Des Moines, Ia.

## PUBLISHER'S NOTES.

### YOUR VACATION IN COLORADO.

Colorado is an ideal place to spend a summer vacation. It has been brought nearer the East by the fast train service of the Chicago, Burlington & Quincy Railroad, only one night on the road from Chicago or St. Louis to Denver.

The fare during the summer is only about one-half the regular fare, and on certain days less than half.

Colorado has hundreds of moderate priced hotels and boarding houses, more perhaps than any other summer resort country. The prices range from \$8 a week upward.

Nowhere can such a glorious combination of climate and scenery be found as in Colorado. The air invigorates, strengthens, revives; it is Nature's own tonic. All the outdoor sports that can be enjoyed anywhere are possible in Colorado. There are many golf courses and the finest kind of trout fishing.

Consider these facts carefully and write me for a copy of the Burlington's "Handbook of Colorado." It does not attempt a description of Colorado's charms, but it does tell facts about 200 or more hotels and boarding houses; shows the location, how reached, name and address of proprietor, rates by the week and month, principal attractions, etc. No charge for a copy. Will be glad to send copies to your friends.

P. S. Eustis,  
209 Adams Street, Chicago, Ill.

### HAVE WINGS AND FLY HIGH.

New York.

Messrs. Wing & Son:

For the past 5 years I have been using one of your pianos in the Kingston hotel, and am so satisfied with the instrument that I feel obliged to write you on the subject. To anyone in need of a first class piano my advice is to buy a Wing.

G. C. Howe, proprietor.  
New York.

Messrs. Wing & Son:

It is with pleasure that I testify to the great merits of your celebrated piano. The instrumental attachments are perfect, and the tone is mellow and lasting. Your piano can stand on its own merits and needs no recommendation.

Geo. W. Sweeney,  
Proprietor Victoria Hotel.  
New York.

Messrs. Wing & Son:

Dear Sirs:  
I cheerfully recommend the Wing piano.

Its tone is rich and mellow, and well suited for orchestral work, as well as instrumental.

Al. Givers,  
Leader Endicott Hotel Orchestra.

### TWO TO FIFTEEN DAYS' PLEASURE TOURS

To meet the demand for information concerning tours to the Adirondack Mountains, Thousand Islands, Niagara Falls, the St. Lawrence River, the Saguenay, Lake Champlain, Lake George, the Green Mountains, etc., that can be made in 2 to 15 days, the New York Central has reissued "Four Track Series" No. 8, entitled "Two to Fifteen Days' Pleasure Tours."

This publication is a booklet of 80 pages, and gives itineraries and fares to all of the above resorts, and, in addition, just the information necessary to the tourist in arranging a trip.

Contained in the booklet are 37 maps of the various routes that enable the prospective traveler to know before starting on his journey just what territory he will cover.

The book is embellished with attractive half tone engravings, and should be in the hands of every one contemplating a summer trip. It will be sent free, postpaid, on receipt of a 2 cent stamp, by George H. Daniels, General Passenger Agent, Grand Central Station, New York.

The latest patent and improved canvas folding boat on the market is that made by The Life Saving Folding Canvas Boat Co., of Kalamazoo, Mich. This boat has a steel frame, is puncture proof, has no bolts to remove, and it folds the most compactly of any boat made. Here is what 2 buyers say of it:

Dear Sirs:

We are much pleased with the new idea of your patent boat lining and keel. It does away with the objectionable feature of the old style boat, that ugly looking keel rising 4 inches or more in the middle of the boat. Your flat keel is the crowning feature of the best all around boat ever built.

Respectfully yours,  
Horace & Roberts,  
Nashville, Tenn.

An illustrated circular, giving prices and descriptions and showing cuts of the different models, will be mailed free on application to the makers. See their ad on page liv of this issue. Please mention RECREATION.

The Graphol Chemical Company, of 90 William street, New York city, have lately brought into the market preparations of surprising simplicity for sensitizing various materials. Their Graphol blue produces beautiful pictures on stationery, envelopes, linen, silk, white canvas, glass transparencies, etc. Their Graphol brown can be applied to the same materials, also to wood, making pictures on wood similar to burnt-wood effects. The method of printing is so simple that every amateur will wish to have these preparations in his outfit.

The Graphol blue, as well as the Graphol brown, comes in powder form, and any part of these powders, when diluted in water, in proportions stated in the directions, can be used. These powders, if protected from light, keep their photographic qualities, and there is no waste connected with them. Read the ad of these goods in this issue, and write the manufacturers for further information. Please do not fail to mention RECREATION.

"The Complete Campers' Manual" is more fascinating than a novel, and as full of information as a dictionary. The manual is written and published by Buzzacott, the famous authority on everything pertaining to camp life. In it he tells how to outfit for every possible emergency of camp life, and how to improvise conveniences and comforts from materials at hand, if lacking a regular equipment. He also tells what not to do, which is often most important. The marvelously ingenious devices he describes are illustrated, and the book is a lure to win the most indifferent to have a try at camp life, while the experienced camper can find new ideas in the Manual that will be worth many dollars to him. A copy of this invaluable book will be sent free to each reader of RECREATION who will write Buzzacott, Racine, Wis., and mention RECREATION.

Yawman & Erbe, Rochester, N. Y., have issued a new catalogue of their fishing reels which contains a lot of excellent illustrations of the automatic reel and of the methods of using it. By examining this pamphlet you will learn exactly how it is that the little finger does it, leaving your left hand free for hanging on trees, the bank, or for handling your pipe or whatever else you may have use for it to do. The book is as full of information as a hickory nut is of meat, and every angler should have a copy.

Yawman & Erbe are in the field again with an offer of 5 cash prizes for the largest fishes taken with their reels during the present season. Two of these prizes, \$15 each, are offered to boys and girls under 16 years of age.

In writing for the book please mention RECREATION.

"Hints to Tourists" is the name of a new and most attractive booklet issued by the Chicago & Northwestern Railway Company, to answer the vacation questions, Where Shall I Go? How Get There? What Will It Cost? The booklet gives information in regard to shooting, fishing and camping resorts in the beautiful lake and forest regions of Minnesota, Wisconsin, Michigan, Montana, Illinois, Iowa and the Dakotas. This information includes a map of the C. & N. W. Ry., rates of transportation, connections, lists of hotels and boarding houses, kinds of game and fish to be found at each resort, and practically all the data a tourist can need to aid him in planning his vacation. Besides, it is beautifully illustrated.

Write for a copy of "Hints to Tourists," and please say you saw it mentioned in RECREATION.

The Old Hickory Chair Co., of Martinsville, Ind., is making a sectional metal boat that bids fair to become popular among sportsmen as soon as a few of the boats are distributed. This company has established an enviable reputation for good work through the medium of the old hickory furniture of which they have sold great quantities during the past few years. We are using a lot of their rocking chairs, dining chairs, etc., at the Mashipacong Club, and I have never seen better work or better material employed in any such work than in this furniture. It is fair to assume that the boats will be made with the same care and in the same thorough manner as the furniture, and sportsmen may therefore feel perfectly safe in ordering these sectional boats. Write for descriptive circular and mention RECREATION.

To keep 7 playhouses open all summer, and all under one management, is a task few theatrical impresarios attempt in these days. F. F. Proctor is a notable example of the type of manager who believes in doing things that the majority of his confreres fight shy of. Mr. Proctor, announces, for instance, that not one of his 7 playhouses will close its doors this summer, and his staff are already hard at work making the necessary preparations for a hot weather campaign. These preparations include laying in a stock of 20,000 big palm leaf fans; covering the plush chairs with cool, smooth linen covers; overhauling the ventilating system of each house; replacing the winter draperies with light and airy stuffs, and a score of other details like these.

The passenger traffic department of the Canadian Pacific railway has issued its year book, entitled "Fishing and Shooting on the Line of the C. P. R." The present volume is fully up to the standard of its predecessors in the great fund of valuable detailed information it gives as to where to find the various species of game and fish in the Canadian Pacific country. The book is handsomely illustrated, contains synopses of the game laws of all the Canadian Provinces, maps, names of local agents of the C. P. R., and much other matter of vital interest to sportsmen who intend to visit that country. Write Robert Kerr, Traffic Manager of the C. P. R., Montreal, and mention RECREATION.

The frequent need of a good portable boat is apparent to every sportsman. This need is fully met by the King folding canvas boat. It is strong, serviceable, equal in every respect to a well built wooden pleasure boat, but it can be easily and quickly folded and as easily set up again. It is perfectly safe for women and children as well as for men, and it does not require an outlay every year to make it ready for use.

The manufacturers issue a handsome catalogue illustrating the many models of these folding boats and giving full information about them. Write for a copy of the catalogue and please mention RECREATION.

The Century Camera Company, of Rochester, New York, is putting on the market a new Curtain Slide Shutter which is attracting much attention among photographers. It is especially adapted for taking subjects in motion or requiring, for any reason, particularly short exposures. It should prove invaluable to amateurs who wish to secure choice photographs of birds and animals. The many readers of RECREATION who are interested in such work should write for descriptive circular and speed table. In doing so please say you saw the shutter mentioned in RECREATION.

Louisville, Ky.

The Luther Glove Co.,  
Berlin, Wis.

Dear Sirs:

The gloves reached me safe, and fit me perfectly. They are most excellent, and I thank you for them; also RECREATION'S generous editor, Mr. G. O. Shields, for making it possible for me to earn them. I shall not fail to tell my friends how I got and who makes the gloves.

Yours respectfully,  
Dr. E. D. Jackson.

The Beekman Novelty Co., 317 Broad-

way, New York, has put on the market a neat and handy device for filling fountain pens which is sure to prove popular. It does away with all the annoyance to which users of these pens have been subjected in the past, and makes the task a brief, simple and pleasant one. Read the ad of the company in this issue of RECREATION and send for one of the instruments. Please mention RECREATION.

Maher & Grosh Co.,  
Toledo, Ohio.

Dear Sirs: I have used many kinds of German, English and American razors, but your No. 3 Barbers' razor puts them all in the shade. Shaving with most razors is more or less of a discomfort, but with the No. 3 it is a luxury. Please send me another razor like it, for which I enclose \$1.25.

J. Bebb, Santa Barbara, Calif.

Every angler who values time or comfort should write J. M. Kenyon & Co. for a copy of their little book describing the Fisk aerating minnow pail. This clever contrivance is bound to save a lot of hard work, a great deal of waste and much bad language. The book tells you all about it. In writing please mention RECREATION.

Messrs. Spratts Patent furnished the outfit for the Ladies' Kennel Association's Show at Hempstead, L. I. This was the first open air show of the season. The entries were numerous. The benching, feeding and fitting up of the exhibition were entirely under the charge of Messrs. Spratts Patent.

The Ideal Mfg. Co., of New Haven, Conn., has made up and put on the market another new bullet, number 429239. A circular, giving full information regarding it, may be had by addressing the company, as above.

RECREATION is one of the best magazines I have ever read.

Harry E. Maybee, Laclede, Mo.

RECREATION is the best paper out for sportsmen.

Kenneth Townshend, Amherst, N. S.

RECREATION is exceedingly popular here.  
Rev. G. D. Bayne, Pembroke, Ont.

RECREATION can not be outdone.

C. F. Shattuck, Worthington, Minn.

I dearly love RECREATION.

C. B. Paul, M.D., Des Moines, Iowa.

## EDITOR'S CORNER.

### HANSON IS ON THE WARPATH.

Mr. G. O. Shields, New York,

Dear Sir—Mr. Hanson, of Worcester, has placed in my hands a claim against you for damage done him by an article appearing in your magazine, April, 1903, issue. I have found that this article was inspired by malice and with a purpose to injure Mr. Hanson. Unless this matter is adjusted forthwith I am instructed by Mr. Hanson to bring suit in the premises.

Chas. O. Engstrom.

Mr. C. O. Engstrom, Boston, Mass.,

Dear Sir—If you have learned that my criticism of S. E. Hanson was inspired by malice, you know more about me than I know about myself. I never saw the man and never heard of him until this matter came up, and you will certainly claim in court, if the matter should go so far, that he has done nothing in this connection to excite my anger.

For 8 years past I have been criticising and rebuking men who slaughter game and fish, and I can show you hundreds of articles in RECREATION equally as severe as the one relating to Mr. Hanson. I have been actuated in all these cases simply by my deep interest in the subject of game and fish protection. I consider that in taking so large a number of fish at one time and place, and in the manner described, and then in publishing this exploit as creditable, Hanson showed an utter lack of the true spirit of sportsmanship and made himself what is known throughout the entire country to-day as a fish hog. Such slaughter, if indulged in by fishermen generally and countenanced by the public, would soon result in the destruction of the entire fish supply of this country, and thus work an irreparable damage to the community. As the president of the League of American Sportsmen, and as the editor of a magazine devoted to shooting, fishing and nature study, I deem it not only my right, but my duty to characterize such conduct as that of Hanson in a way to arouse public sentiment against it, and I insist that my criticism of Mr. Hanson was made without malice and entirely within legitimate bounds. It is not, therefore, subject to the action you propose bringing.

It may interest you to know that my efforts in this direction have proven generally successful. I have on file thousands of letters from men who say frankly that they have been game or fish hogs all their lives and never stopped to think of the harm they were doing until I inaugurated this warfare against such work, and that

they have now reformed; that they quit when they get enough and advise their friends to do likewise. If after considering this matter from my point of view, you still persist in bringing an action against me, I can not, of course, prevent you from doing so.

G. O. Shields.

### THE ODELL GOLD STORAGE LAW.

Governor Odell has already had several opportunities to see how gloriously his cold storage game law is working. The Arctic Freezing Co., against which an action has been pending some 2 years for having had over 50,000 birds in possession, in violation of law, has again been investigated by a State game warden, who found in the possession of this company more than 10,000 ducks, snipe and plover that had been placed in cold storage without bonding and sealing as provided by law.

The manager of a cold storage plant in Jersey City came to me a few days ago and asked me if he would be allowed to keep game in cold storage in that State in close season. I told him he would certainly be subject to arrest and punishment if any game were found in his place after the close of the legal selling season. He explained that a New York game dealer had asked him to accept several barrels of ducks which he had in possession at that time, explaining that he did not care to store them on this side of the Hudson because of the law which required that game held in storage here in close season should be bonded and sealed. Every man who has had anything to do with the enforcement of the game laws in this city knew when the Odell cold storage bill was passed that it would be violated, and this is being done. It would be interesting to see a list from the State game and fish commission of the names and addresses of dealers who have complied with the bonding law by placing game in cold storage under bond. Will not the governor have such a statement published?

I find by consulting the files of RECREATION that, up to and including the June issue, 876 men and women have been rebuked for slaughtering game, song birds or fish. I deeply regret the necessity of saying "and women," but must tell the truth.

Therefore, beginning with this, the July issue, each man and each woman who may come into the pen in future will be given a serial number.





**Schlitz**

THE BEER  
THAT MADE  
MILWAUKEE  
FAMOUS.

## **We Go to Bohemia for Hops**

We send our own buyers there every year to get the best that are grown, and we pay for them twice what common hops cost.

A partner in our business buys our barley, and selects the best from all.

We get our water from six wells, bored to rock.

Our yeast is all developed from the original mother cells which helped make Schlitz Beer famous.

## **We even filter air**

All the air that touches Schlitz Beer comes to it through air filters.

And the beer itself is filtered through white wood pulp.

Then we age it for months, until it cannot cause biliousness.

We sterilize every bottle,

## **Yet Schlitz Beer costs only common beer prices**

*Ask for the brewery bottling.*

## THEY STILL REMIND PETERS.

Binghamton, N. Y.

The Peters Cartridge Co.,  
Cincinnati, Ohio:

Dear Sirs:—I have been reading your troubles in RECREATION and fail to see that Mr. Shields has done anything injurious to you. It looks to me as if you were in your own light, and going wrong. I have used your ammunition for years and find it good but had trouble with shells in the Winchester repeater, the same as mentioned in the article to which you object, though I never took the trouble to tell of them through the press. I think it a personal affair between you and every sportsman. I believe the sportsmen will stand by the editor of RECREATION, and that the sale of your goods will decrease if you do not advertise in that magazine. I spend one to 4 months in the game fields as guide and game protector, always dictating the kind of ammunition to be used, besides using large quantities myself.

Last fall, while in the Adirondack mountains with a party of 4, I had trouble with some U. M. C. shells, and wrote the firm about it. They at once remedied the trouble and sent me, express prepaid, some of the improved make. Perhaps it would have been well for the man who had trouble with your goods to have written you personally instead of doing as he did; but I hope and trust you will reconsider, drop your ill feeling towards the editor of RECREATION, and continue doing business in a businesslike manner.

R. R. Mathewson.

San Antonio, Texas.

The Peters Cartridge Co.,  
Cincinnati, Ohio:

Dear Sirs:—In RECREATION for May, I note an article wherein you claim you have a grievance. I do not think you have, and think you have acted unwisely in ordering your ad discontinued. If Mr. Radcliff's letter had been false, it would have done you good rather than harm. It would have drawn as much comment, favorable to your goods, from Shields' 75,000 subscribers, as he could have printed. This would have given your firm thousands of dollars' worth of free advertising. I would have contempt for a 6-year-old boy who would get red headed about a thing like that. Just look at the note in a recent issue from a man in Edmonton, N. W. T. See how he condemns the Winchester rifle, which is the best made. Did the Winchester people get mad and order their ad stopped? No, they are too old for such foolishness.

I have used your ammunition and found it O. K. The W. R. A. and the U. M. C. companies, however, make just as good and have done so for a long time.

RECREATION is the official organ of our League, and is published by one of us. The editor, Shields, goes down in his jeans for many a dollar to protect our game and

deserves great credit for his good work. If your ad is permanently discontinued in RECREATION I have shot my last Peters' cartridge.

L. A. S., 2239.

Schenectady, N. Y.

The Peters Cartridge Co.,  
Cincinnati, Ohio:

Dear Sirs:—I see by a letter in May RECREATION that you have withdrawn your ad from the magazine because Mr. Shields allows a reader to express his opinion of your shells. I am more than surprised that a firm that makes a good shell should play the baby act. RECREATION is the official organ of the L. A. S. and as such must be open to its members. When I see anything to criticise, even though it is advertised in RECREATION, I want and expect its pages will be open to me. When it refuses me that right, I shall refuse to take it. I lost \$16 through an ad in a paper where the editor was constituted judge by the advertisers; but we don't put Shields up for that position. We reserve the right to judge for ourselves.

J. W. Furnside.

Mount Morris, N. Y.

The Peters Cartridge Co.,  
Cincinnati, Ohio:

Dear Sirs:—In the May number of RECREATION there appears a copy of a letter written by you to Mr. G. O. Shields, editor and manager of that magazine. This letter puts forth a vigorous kick about some slight criticism which was made against your shells. If any irregularity exists in your shells you have taken a queer stand toward rectifying it, as you actually concede the superiority of other brands. The action you have taken toward a magazine which has upheld you so nobly in the past is childish and it is reasonable to believe that all the true sportsmen will uphold Mr. Shields in this matter.

K. S. Chamberlain.

We are all down on Peters' shells here. Our dealer says he can not sell goods of theirs that he bought 5 years ago. I have the highest possible regard for RECREATION, as I am receiving more information from its pages than from all the other magazines I take.

F. G. Ellis, Lime Grove, Ia.

I think it far better that Peters' goods are not advertised in RECREATION. I bought some Peters' Ideal shells in 1900. I tried 15 July 4th, 1902, and none of them would go. The primers were driven in 3-16 of an inch. All the rest is trash.

Chas. Vitous, East Pittsburg, Pa.

# THE EQUITABLE

**HENRY B. HYDE**  
FOUNDER

**J.W. ALEXANDER**  
PRESIDENT



**J.H. HYDE**  
VICE PRESIDENT

## YOUR DECLARATION OF INDEPENDENCE

is signed when you  
become the holder of an Endowment  
policy in the Equitable.

It gives you freedom from worry  
about either your own future—or  
the future of your family.

It provides for yourself—if you  
live, and for your family—if you die.

Vacancies in every State for men of energy and character to act as representatives.

Apply to **GAGE E. TARBELL**, 2<sup>ND</sup> Vice President

Send this coupon for particulars, or write  
**The Equitable Life Assurance Society of the United States**  
120 Broadway, New York. Dept. No. 16

Please send me information regarding an Endowment for \$.....  
issued at.....years of age.

Name.....

Address.....

## AMATEUR PHOTOGRAPHY.

"For sport the lens is better than the gun."

*I wish to make this department of the utmost use to amateurs. I shall, therefore, be glad to answer any questions and to print any items sent me by practical amateurs relating to their experience in photography.*

### 8th ANNUAL COMPETITION.

RECREATION has conducted 7 amateur photographic competitions, all of which have been eminently successful. The 8th opened April 1st, 1903, and will close November 30th, 1903.

Following is a list of prizes to be awarded:

First prize: A Long Focus Korona Camera, 5 x 7, made by the Gundlach Optical Co., Rochester, N. Y., fitted with a Turner-Reich Anastigmat Lens, and listed at \$85.

Second prize: A No. 3 Folding Pocket Kodak, made by the Eastman Kodak Co., Rochester, N. Y., fitted with a Bausch & Lomb Lens, Plastigmat Unicum Shutter, and listed at \$61.50.

Third prize: A Royal Anastigmat Lens, 4 x 5, made by the Rochester Lens Co., Rochester, N. Y.; listed at \$36.

Fourth prize A Waterproof Wall Tent, 12 x 16, made by Abercrombie & Fitch, New York, and listed at \$32.

Fifth prize: An Al-Vista-Panoramic Camera, made by the Multiscope and Film Co., Burlington, Wis., and listed at \$30.

Sixth prize: A No. 3 Focusing Weno Hawk-eye Camera, made by the Blair Camera Co., Rochester, N. Y., and listed at \$27.50.

Seventh prize: A high grade Fishing Reel, made by W. H. Talbot, Nevada, Mo., and listed at \$20.

Eighth prize: A Tourist Hawkeye Camera, 4 x 5, and made by the Blair Camera Co., Rochester, N. Y., and listed at \$15.

Ninth prize: A Bristol Steel Fishing Rod, made by the Horton Mfg. Co., Bristol, Conn., and listed at \$8.

Tenth prize: A pair of High Grade Skates, made by Barney & Berry, Springfield, Mass., and listed at \$6.

The 10 next best pictures will each be awarded one dozen 8 x 10 Carbutt Plates, made by the Carbutt Dry Plate Co., Wayne Junction, Philadelphia, Pa.

The 10 next best pictures will each be awarded one dozen 5 x 7 Carbutt Plates.

The 10 next best pictures will each be awarded one dozen 4 x 5 Carbutt Plates.

A special prize: A Gperz Binocular Field Glass, listed at \$74.25, will be given for the best picture of a live wild animal.

Subjects are limited to wild animals, birds, fishes, camp scenes, and to figures or groups of persons, or animals, representing in a truthful manner shooting, fishing, amateur photography, bicycling, sailing or other form of outdoor or indoor sport or recreation. Awards to be made by 3 judges, none of whom shall be competitors.

Conditions: Contestants must submit 2 mounted prints, either silver, bromide, platinum or carbon, of each subject, which, as well as the negative, shall become the property of RECREATION. Negatives not to be sent unless called for.

In submitting pictures, please write simply your full name and address on the back

of each, and number such prints as you may send, 1, 2, 3, etc. Then in a letter addressed Photographic Editor, RECREATION, say, for instance:

No. 1 is entitled — — —.

Made with a — — — camera.

— — — lens.

On a — — — plate.

Printed on — — — paper.

Length of exposure, — — —.

Then add any further information you may deem of interest to the judges, or to other amateur photographers. Same as to Nos. 2, 3, etc.

This is necessary in order to save postage. In all cases where more than the name and address of the sender and serial number of picture are written on the back of prints I am required to pay letter postage here. I have paid as high as \$2.50 on a single package of a dozen pictures, in addition to that prepaid by the sender, on account of too much writing on the prints.

Any number of subjects may be submitted.

Pictures that may have been published elsewhere, or that may have been entered in any other competition, not available. No entry fee charged.

*Don't let people who pose for you look at the camera. Occupy them in some other way.* Many otherwise fine pictures have failed to win in the former competitions because the makers did not heed this warning.

### BUYING THE FIRST CAMERA.

R. S. KAUFMAN.

For the prospective buyer, a collection of catalogues of the different makes of cameras and the study of them will eventually result in his asking every one who knows anything about photography, "Which make do you consider the best? Which do you prefer, plates or film? Which gives the best results, a box camera or a folding style? Is a tripod necessary? What kind of lens makes the best pictures?"

If the prospective purchaser lives in the city, such questions can readily be answered by demonstrations, unless the dealer favors only one make, which is often the case, saying that films are superior to plates, etc. The person who does not have the opportunity of a critical examination is seriously handicapped, and must arrive at a decision by learning from the pages of the catalogue what will best meet his needs.

As to the make, one can always depend on the firms that advertise in RECREATION. The names of Premo, Poco, Century, Korona, Kodak, Hawk-Eye, Al-Vista, etc., are all reliable, and can be depended on.

Plate or film, however, is a matter that requires individual consideration. Personally, I say plates, but as a dealer, when I

have a customer I do not discriminate. I explain the good and bad points of both plates and films. Seven-tenths of the beginners choose film cameras, because they can make 12 exposures in as many seconds. The average person buying a camera thinks that to make pictures it is only necessary to push a button, or squeeze a bulb, under any conditions of light, either outdoors or in. Films are much more expensive than plates, and there is but one grade to choose from. Plates are heavier, but many points are in their favor. One can have a  $6\frac{1}{2} \times 8\frac{1}{2}$  camera, make pictures  $6\frac{1}{2} \times 8\frac{1}{2}$ ,  $5 \times 8$ ,  $5 \times 7$ ,  $4 \times 5$  or  $\frac{3}{4} \times 4\frac{1}{4}$ , by using kits. When occasion requires, an extra rapid plate can be used. Isochromatic and orthochromatic plates can be used to photograph flowers of different colors, thus giving an unlimited assortment of material to select from.

The foundation of the picture is laid in developing. For an exposure made on a dull gray day, when the light is flat and there is no contrast, the developer can be so compounded that the contrast will be increased. An under exposure can more readily be controlled by developing prints one at a time; while films are developed in the roll, of 6 or 12 exposures.

The new film pack, just introduced by the Rochester Optical Company, makers of Premo cameras, will be hailed with delight. It is at present made in the  $3\frac{1}{4} \times 4\frac{1}{4}$  size only, but will soon be made in all sizes. The film pack adapter closely resembles an ordinary plate holder. Two metal fasteners hold the back and front together. The front has a slide and is operated like a plate holder. The film pack and adapter are easily manipulated. The pack is placed in the adapter, the back of which opens, and the adapter is then inserted in the camera exactly like a plate holder. The pack contains 12 films. When exposures are to be made, the slide is drawn out, the black paper tab is removed, and the slide can be replaced, and another object focused on. In this manner the 12 films may be exposed, or the film pack adapter removed and the plate holder used in the regular way. The film pack can be loaded and unloaded in daylight. This feature will be appreciated by plate enthusiasts, as a supply of film for several weeks may be included in one's luggage and exposures made in the same manner as if plates were used; whereas to carry this number of plates would be next to impossible.

The style of camera depends on the energy you can spare. The box camera is made for plates or films, and no focusing is necessary, as the lenses are of the universal focus type, and the picture in focus, or, in other words, clear, at all distances. This camera is all right for memorandum work,

for children, or for one who does not wish to bother with focusing; but if you wish pictures, and intend to take up photography seriously, get a folding style; one with a ground glass or focusing screen, so you can study your subject.

Is a tripod necessary? Certainly, if you wish pictures. The camera should be held in the hand only in the case of instantaneous exposures, not more than 1-25 of a second, so that the movement of the camera is not perceptible. By using a tripod exposures of any duration may be made; and no one working for good results will make an exposure without a tripod.

The lens question is important, and must be left to the pocketbook for decision. The best you can afford is none too good. Cameras, as regularly equipped, contain good lenses, but better results are assured from the start by getting a good lens of the anastigmat type, of which there are many good makes. A good lens is one that works with a large opening or aperture, for quick exposures when desired, and can be used as a single lens when occasion demands.

For real satisfaction, and perfect picture making, a camera with a long draw, or bellows, a good anastigmat lens, and a reliable make of plates are essential; but with all this do not forget that the man behind the gun is the principal factor.

#### AS TO PRIZE WINNERS.

Would it not be advisable to divide the entries in your next photo competition into 2 classes, putting the photos of wild animals together? They are more interesting, are much harder to get, and should win over ordinary pictures; but the fellow who has neither the means nor the time to make a trip necessary to secure an animal subject does not stand much show, although his may be as artistic and pleasing a picture as the other fellow's. The wild animal class should have the more valuable prizes, but can you not make a second class, excluding wild animals?

H. J. Flint, Providence, R. I.

#### ANSWER.

I have thought a great deal about the proposition you make, for several years past, and have discussed it with several people, but have been unable to effect any plan that seemed better than the one I have been following. For 2 years past I have offered a special prize for the best picture of a wild animal, considered with reference to the general artistic qualities of the photograph; and inasmuch as I do not give one person 2 prizes, this has eliminated the best wild animal picture from competition with the good ones of other subjects. If you have a file of RECREATION for 5 or 6 years past and will go through them, examining carefully

the prize-winning pictures as published, you will find that in several cases the 1st to 5th prizes have been awarded to other than animal or bird pictures. Of course, many prizes have been given to pictures of live things; but they have not taken all by any means, nor even all the best prizes.

If I can hit on any plan of improving the present method of offering and distributing prizes so as to give the unfortunate stay-at-homes a better show, I shall be glad to do it. I realize that many expert amateur photographers can not afford the time and expense of going into the woods and making pictures of live wild animals or birds, and that they must therefore depend on subjects which can be reached within the bounds of civilization.—EDITOR.

#### A DEVELOPER FOR CYKO.

Not being satisfied with my results on Cyko with metol hydroquinone, after trying a great many combinations I have settled on 2 satisfying formulas:

##### A.

Water .....	4 ounces
Sodium sulphite (anhydrous)...	1 dram
Acetone sulphite.....	4 grains
Edinal .....	18 "
Sodium carbonate (anhydrous). 45	"

Potassium bromide, 5 per cent. solution, as needed.

##### B.

Water .....	4 ounces
Sodium sulphite (anhydrous)...	2 drams
Acetone sulphite.....	4 grains
Edinal .....	18 "
Potassium carbonate.....	1 dram

Potassium, 5 per cent. solution, as needed.

The potassium bromide is not made up with the stock solution, but is added with a dropper at time of development, as needed.

Edinal is extremely sensitive to bromide's drop. One of a 5 per cent. solution in formula A is generally enough to hold the whites; but this varies somewhat. Development is moderately slow, there is no choking of the high lights and the detail in the shadows is well brought out. The acetone sulphite restrains the development and gives a pleasant grayness to the half tones. It also tends to prevent the greenish tinge given the black by the bromide.

In formula B a little more bromide is required. This formula gives a bluish tinge to the blacks, but this can be controlled by the addition of potassium bromide, which, if added in sufficient quantity, will give pure blacks, but if added in excess will give greenish blacks. I use the regular cyko acid, fixing both, and get no blisters. The greater percentage of my failures were caused by iron or sulphur in the water, sulphur in the air, or hypo from the hands

or trays. By care one can prevent trouble from these causes.

R. L. Wadhams, M. D.,  
Wilkes-Barre, Pa.

#### SNAP SHOTS.

What is the matter with my lens? If I focus on the center of the ground glass the sides are out of focus and if I focus on the sides the center is out of focus. I fitted the lens in the shutter myself.

Ira Schryver, Deer Creek, Minn.

#### ANSWER.

If you will observe the manner in which your lens is ground you will see that its center is actually nearer objects than its sides. The focal planes of center and sides are different; therefore, objects appearing at the sides will not be sharp when you focus with center of your lens. By stopping down with diaphragms so as to make most of the light rays pass through center of lens, sharper focus can be obtained. As you have not given the name of your lens, I can say little about its quality; but if the differences between the focal results of sides and center are great you can take it for granted that your lens is not of the late and improved sort.—EDITOR.

I see that Stephen Mars, of Taunton, Mass., inquires if others are using Argo papers. I use it exclusively. I used Cyco a while, but it stained badly and was inclined to develop unevenly, especially if developer did not flow instantly over the entire surface of paper. I have the same trouble with Velox, in my developer, which is as follows:

Water (distilled or soft).....	4 ounces
Metol .....	30 grains

Shake well and add—

Sodium sulphite (crystals)....	½ ounce
Sodium carbonate (granular)..	⅜ ounce
Potassium bromide.....	2½ grains

Shake until dissolved and use with 3 parts water. This is enough for 100 cabinet prints.

C. E. Pleas, Chipley, Fla.

A photographic expedition, organized and headed by G. O. Shields, editor of RECREATION, will leave Donald, B. C., July 28th. Mr. Shields contemplates a trip that for adventure and endurance will make better reading matter than has yet been provided by the intrepid explorer of the Northland. His route is North from Donald and West through the Yellowhead pass, thence South and East, coming out at Banff or Laggan. Four different summits have to be crossed. Mr. Shields will take photographs of wild animals and scenery.—B. C. paper.

# EASTMAN'S Kodoid Plates

ORTHOCHROMATIC  
NON-HALATION

THE PERFECT SUBSTITUTE FOR GLASS

USED IN ORDINARY PLATE HOLDERS WITHOUT  
KITS OR ADAPTERS

KODOID PLATES consist of non-curling cut film, mounted by means of metal clips on a black cardboard. Before development they are handled precisely like glass plates. To develop, they are removed from cardboard by pulling off the clips, and are then developed in the usual manner.

Superb in Speed, Latitude and Chemical Quality  
Light—Convenient—Non-breakable

## KODOID PLATE PRICE LIST

3¼ x 4¼, per dozen, . . . \$0.45	4¾ x 6½, per dozen, . . . \$1.00
4 x 5, per dozen, . . . . . .65	5 x 7, per dozen, . . . . . 1.10

SOLD BY ALL KODAK DEALERS

EASTMAN KODAK CO., Rochester, N.Y.

OBJECTS WELL CENTERED AND CORRECTLY FOCUSED

# The Focusing Weno Hawk- Eye

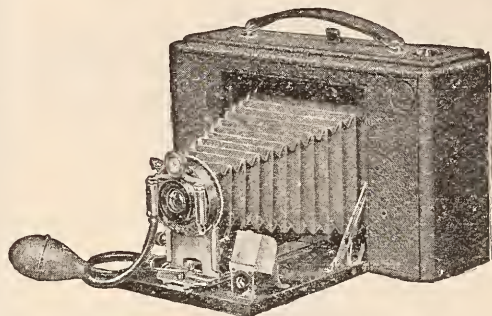

has the advantage  
over all cameras

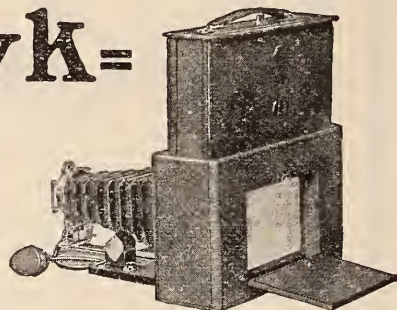

of a ground glass the size of picture, which works automatically and allows focusing when using film. The result is obvious—perfection of work—satisfaction to the user.

**No. 3 Focusing Weno Hawk-Eye, with B. & L. Automatic Shutter, and Extra Rapid Rectilinear Lens. Pictures  $3\frac{1}{4} \times 4\frac{1}{4}$ , - - - \$27.50**

**No. 4 Focusing Weno Hawk-Eye, same equipment. Pictures  $4 \times 5$ , 30.00**

Hawk-Eye Film can be developed in the Kodak Developing Machine.

*Write for Hawk-Eye Booklet.*

**BLAIR CAMERA CO., Rochester, N. Y.**

## Do you want A Folding Canvas Boat?

IF SO, SEND ME

35 yearly subscriptions  
to RECREATION

AND I WILL SEND YOU

A 14 ft. King folding canvas  
boat listed at \$48

capable of carrying 2 men and an ordinary camp outfit. There are thousands of these boats in use, and nearly every man who is using one of them praises it on every occasion.

Sample copies of RECREATION for use in canvassing will be furnished on application.

Address 23 W. 24th St., N. Y.

## SPRING SHOOTER VS. EGG ROBBER

B. T. I.

Sportsman—"Well, Bob, what luck? Been out duck shooting again? You still go hunting in the spring, I see."

Spring Shooter—"Yes, and only got 2 ducks. If them fellers don't quit gatherin' eggs up North we won't have a duck left by fall."

Sportsman—"True enough, Bob. But what is the difference between the spring shooter and the egg robber?"

Spring Shooter—"Don't know, only them fellers ought to have a year in jail for every egg they steal."

Sportsman—"You are right, they should; but the difference is this: The man who steals the eggs, only gets the eggs, while the spring shooter gets the eggs and the duck at the same time. Therefore, you both should have a life sentence at hard labor."

**Free:** To anyone sending, through me, \$1 for yearly subscription to RECREATION, I will send free a No. 1 Sportsman's Medicine Case; for 2 subscriptions a Physician's Pocket Medicine Case; for 10 subscriptions 1,200 12-gauge primed paper shot shells. This offer is not open to old subscribers who formerly have sent in their subscriptions to the office of RECREATION, but to all others.

Walter Luson, Ardmore, Pa.





## The Pack and the Picture— A Very Simple Matter.

Amateur photographers have received the new PREMO Film Pack with almost extravagant praises. It meets the conditions of the outdoor picture maker as nothing else has ever done. Whether you use a PREMO Plate Camera or a PREMO Film Camera, it opens the easy way to photography;—a working outfit that is unequalled for simplicity and convenience.

# The PREMO Film Pack

## DAYLIGHT LOADING

As flat as a handkerchief in your pocket when not in use, as easy to load in daylight as shutting a book; it is unequalled for effectiveness. Carrying twelve non-curling, orthochromatic films; successive exposures are made by pulling out the numbered black paper tabs. The last tab seals the package light tight. Adapted to  $3\frac{1}{4} \times 4\frac{1}{4}$  and  $4 \times 5$  Cameras, the PREMO Film Pack meets successfully every photographic condition. See it at your dealer's or write for particulars contained in the *Premo Year Book*, free.

**ROCHESTER OPTICAL CO., Dept. 209, Rochester, N. Y.**

# ALVISTA CAMERA



**T**AKES everything within half a circle, making a picture five inches high by twelve inches long; or you can stop the revolving lens at different points and make exposures either four inches long, or six inches, or ten, depending upon how much you want to get in the picture. No wasted film. The revolving lens moves at different speeds, so you can gauge your exposure accurately. The exposure of the film is on the same principle as the focal plane shutter for pictures of moving objects. Our catalogue tells of its many uses—free.

**MULTISCOPE & FILM CO., 136 Jefferson St., Burlington, Wis.**

# AL-VISTA PANORAMIC CAMERA



## THE HEIGHT OF ART in camera work

Perfection in photography, has been secured by the use of the Al-Vista Camera. It produces the entire panoramic view — **from the limit of vision on the left to the extreme point on the right.** The Al-Vista Camera is compact: easy to use, sure in action. It is sold on its merits: we demonstrate this by selling you one

## on easy payments

Ask us for a catalog: select the camera you wish, fill up the blank we shall send you, and references being satisfactory we will at once send you a camera—pay weekly or monthly in sums to suit your purse. The camera is no longer a luxury: the demands of modern progress make a good camera a necessity; we make it easy for you to get the best, an

## Al-Vista.

*The*

## Multiscope & Film Co.

136 Jefferson St.

Burlington, Wis., U. S. A.

---

STILL ANOTHER GREAT OFFER

**A Grade 00 Syracuse Gun**

*Listed at \$30.*

FOR

*25 Yearly Subscriptions*

TO

**Recreation**

If you Want one of the Guns get a move on you

Sample copies for use in canvassing  
furnished on application

---

---

**RECREATION, 23 W. 24th Street, New York**

## YOUR VACATION

Will not be completely enjoyable  
without the companionship of a

## Modern Binocular

But *don't buy* unless you get the

## Very Best Obtainable

And when you're looking for the  
best, please bear in mind that the

# Turner-Reich Field Glass

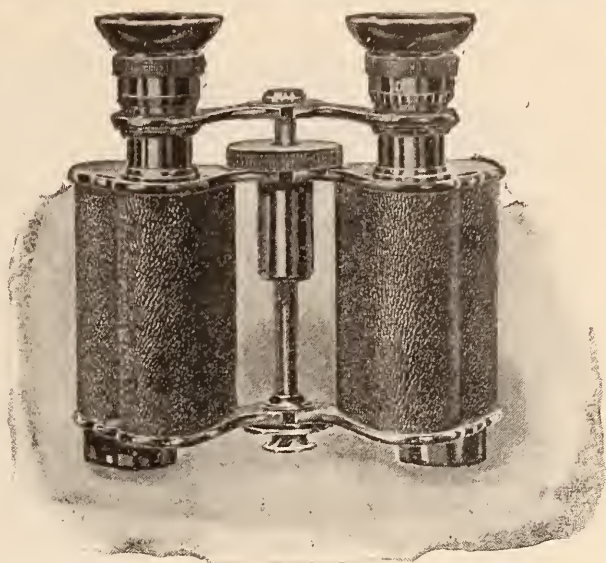

is backed by our **GUARANTEE** of **OPTICAL PERFECTION**

This **GUARANTEE**, in turn, is backed by **NINETEEN YEARS'** study of **OPTICAL**  
and **MECHANICAL** theory, and by **NINETEEN YEARS'** **EXPERI-**  
**ENCE** in putting **THEORY** into **PRACTICE**.

Write for Price List. It tells about the wonderful *defining* and *magnifying* power, and the  
*unprecedentedly large field* of the **TURNER-REICH BINOCULAR**.

## GUNDLACH-MANHATTAN OPTICAL CO.

730 So. Clinton Ave.

ROCHESTER, N. Y.

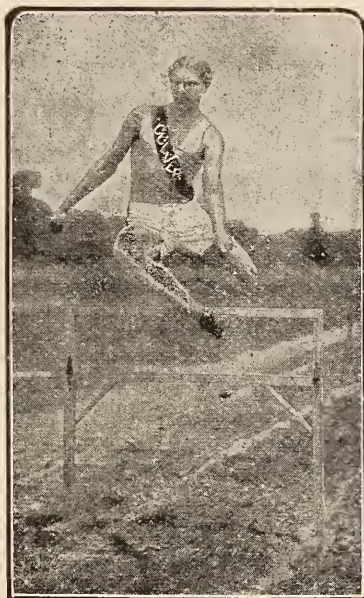

Made with The  
**KORONA**  
**CAMERA**

1884

NINETEEN

IT'S ALL  
IN THE  
LENS

1903

YEARS'

**Optical and Mechanical Experience**

is the **HERITAGE** of the

# 1903 KORONAS

You cannot afford to buy a camera before you've  
seen and examined the new **KORONAS**.

You need an Anastigmat? We have two to offer:

The **TURNER-REICH** and the **VERASTIGMAT**

How about a Wide-Angle Lens in cells to fit your  
shutter? It's an **EMIL** you want.

**Gundlach-Manhattan Optical Co.**

**ROCHESTER, N. Y.**

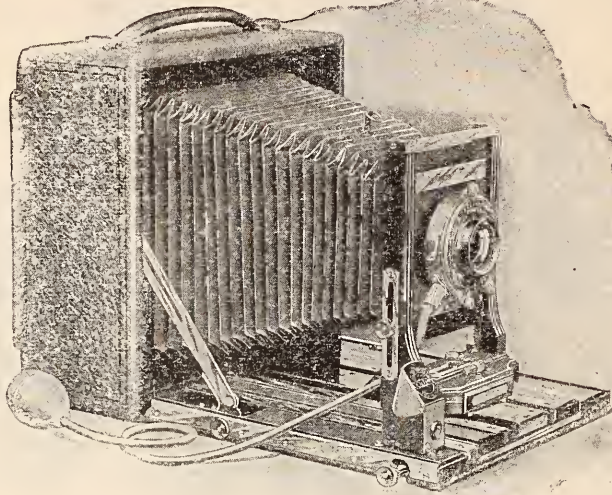

## “Century” Cameras

are the finest in the world and the most for the money. Our New Catalogue tells why. Obtainable from all dealers free, or by mail direct.

## The Superiority — of — Century Cameras

has won for them the highest praise from connoisseurs everywhere.

“Century Quality” is the result of twenty years’ practical experience.

We invite a careful comparison of “Centurys” with any other cameras, for comparisons make the favorable comments regarding “Century Quality” still more numerous and emphatic.

**Century Camera Co.,**  
Rochester, N. Y.

### OIL PORTRAITS ON APPROVAL.

If you will send me a photo of yourself or a friend and state color of hair, eyes and complexion I will paint and send you on approval a miniature oil or pastel portrait.

Canvas 6x8 or 8x10 inches, \$10.00

Canvas 10x12 or 12x14 inches, \$15.00

Z. EMMONS, 58 West 104th St., New York

Reference: Mr. G. O. Shields.

### COLORED PHOTOGRAPHY

Accomplished by the use of

# LOXOL

A new chemical compound which will produce prints colored true to nature. *Booklet Sent Free.*

Beautiful specimens of work produced mounted and handsomely matted, suitable for framing for 25c. in stamps.

Complete outfit from your dealer or from us, express paid, \$2, or smaller size \$1.

**ROCHESTER CHEMICAL CO.**  
177 West Main St. ROCHESTER, N. Y.

# S L E E P

IS TIRED NATURE'S  
SWEET RESTORER

After a hard day's tramp, you must have

### A GOOD NIGHT'S REST

in order to fit you for the next day's work.

Better to sleep on a good bed without your dinner, than sip at a banquet and then sleep on the cold, hard, wet ground.

You can get

### A Recreation Camp Mattress

of rubber, with valve for inflating, made by the Pneumatic Mattress Co. and listed at \$20

For 20 Yearly Subscriptions  
to RECREATION

Send for Sample Copies

Address RECREATION, 28 W. 24th Street, New York



## A New Curtain Shutter

The

# “Century”

The best form of shutter for photographing flying birds, animals in motion, athletic sports, bicycle races and all objects in rapid motion.

**OPERATES FROM “TIME” TO 1-1200TH OF A SECOND.**

The “Century” is the easiest to operate, the most compact, and the lightest curtain shutter in the market. An entirely new feature—and an original Century idea—is the method of adjusting the slot from the outside. Can be attached to both hand and tripod cameras.

PRICE—5 x 7, \$25.00; 6½ x 8½, \$30.00; 8 x 10, \$35.00.

Descriptive Circular and Speed Table  
mailed upon request.

**CENTURY CAMERA CO., Rochester, N. Y.**

**Free:** If you send your subscription to RECREATION through me or direct to the office to be placed to my credit, I will send you free of charge, any one of the articles mentioned below:

Shot gun bench crimper, sells for 75 cents, in 10-12-16-20 gauge.

Shot gun cleaning rod, three attachments, sells for 50 cents, in 10-12-16 gauge.

Micrometer powder and shot measure, adjustable, and for both black and smokeless powder, sells for 65 cents.

U. S. Government rifle cleaner, any caliber, with attachments, sells for 60 cents, packed in neat canvas bag.

A duck, snipe or turkey call, sells for 75 cents each, best made.

A hand painted sporting picture, suitable for framing and just the thing for your den, worth \$1.50.

“Hunting in the Great West,” by G. O. Shields. H. S. Hill, 815 11th Street, N. E., Washington, D. C.

**LANTERN SLIDES COLORED  
SKILLFULLY AND ARTISTICALLY  
FOR  
Lecturers, Teachers and others**

I refer by permission to the Editor of RECREATION.

**MRS. C. B. SMITH**  
606 W. 115th Street, New York City.

## Something New!

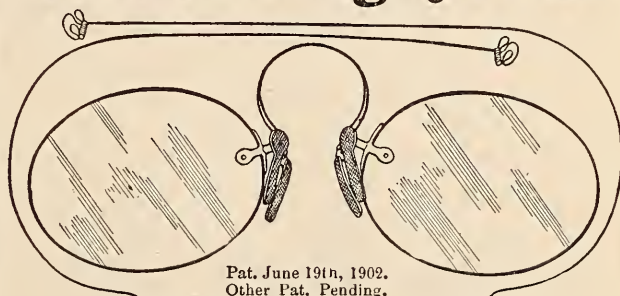

Pat. June 19th, 1902.  
Other Pat. Pending.

### PRESTO! CHANGE! Attachable Eyeglass Temples

Every wearer of eyeglasses wishes occasionally that they were spectacles. Spectacles stay on, however violent one's exercise, however warm or stormy the weather. This little device can be readily attached or detached without injury to the lenses, thus in a second giving you the choice of either spectacle or eyeglass. Just the thing for outdoor sports. The Temple Attachment will fit any of your eyeglasses and can be carried in the same case with them.

Send thickness of lens when ordering by mail.

Price in Nickel, 50 cents a pair  
Price in Gilt, 75 cents a pair.

Send for Circular.

*Our illustrated catalogue can be had for the asking*

We carry everything in the Optical and Photographic line Eyeglasses, Spectacles, Cameras, Opera, Field or Marine Glasses, Thermometers, Barometers, Telescopes, Hygrometers, Sun-dials, etc.

**GALL & LEMBKE, Department C.**

1 W. 42d Street      21 Union Sq., New York  
Established 1842.

---

# Do You Want a Gun?

Send me 30 yearly subscriptions to  
RECREATION and I will send you a

## No. 1 Double Barrel Breech Loading Gun

Made by the Ithaca Gun Co.  
and Listed at \$40

I have contracted for 20 of these  
guns at a price which enables me to  
offer them as above, and they will  
doubtless all be taken within the next  
3 months.

### If You Want One Get Busy at Once

Sample copies of RECREATION for  
use in canvassing furnished on application

---

***RECREATION, 23 West 24th St., New York.***



# The Rocky Mountain Goat

Is a shy, wary animal that ranges  
8,000 to 15,000 feet  
above sea level

and has rarely been photographed. Mr. A. M. Collins, one of RECREATION'S prizewinning photographers, has recently made 4 of the finest goat pictures ever produced. I HAVE had enlargements made from these, 13 x 15 inches, and will sell them

• At \$5.00 a Set.

A rare and valuable group for sportsmen, amateur photographers and nature students. Address

**RECREATION,** 23 WEST 24th ST.  
NEW YORK CITY

**Something Special — Playing Cards Free:**—To each person sending me \$1 for one year's subscription to RECREATION, or sending it direct to be placed to my credit, I will forward, all charges prepaid, a pack of elegant gold edge playing cards. These are no cheap second quality cards but first quality, of extra selected stock, highly enameled and polished, fancy set pattern backs, each pack wrapped in handsome glazed wrapper and packed in strong telescope case.

L. J. Tooley,

141 Burr Oak St., Kalamazoo, Mich.

## Lens Supremacy

Everywhere Acknowledged

Catalog  
Free

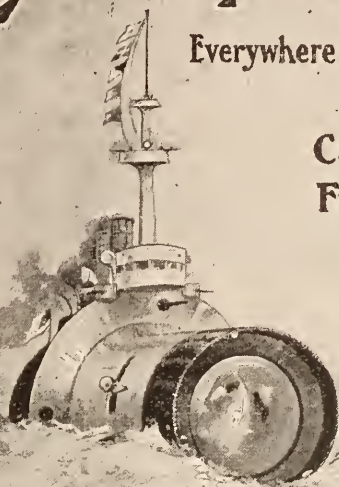

### BAUSCH & LOMB, Lenses & Shutters

\$3,000.00 offered for photos made with them

Rochester, N.Y.

NEW YORK.

BOSTON.

CHICAGO.

There is, in France, a society for the prevention of cruelty to animals. Men visit it each year to apply for the medal it gives annually. It's president is a joker. One day a peasant came to this association and laid claim to the medal.

"What have you done to deserve it?" asked the president.

"I have saved a wolf's life, sir," said the peasant.

"What had the wolf been doing?"

"It had killed my wife."

"Then," said the president, "you need no medal, for you are already sufficiently rewarded."—New York Tribune.

## GRAPHOL

### Photo-Sensitizing Powders.

For making Photos on silk, cotton, linen, duck-canvas, private stationery, envelopes, postal cards, glass, (transparencies), wood, etc.

Graphol Blue (Azuro) full size bottle 25c.

" " Brown (Sepiol) trial " 25c.

" " " full size " 75c.

These latest, most unique, preparations are just being introduced. Your dealer may not carry them in stock as yet. We are, therefore, prepared to send you bottles with directions on receipt of amount in stamps, coin or money order, by mail prepaid.

Do not fail to try these powders; they will give you more pleasure and satisfaction than you anticipate.

**Graphol Chemical Co.**

90 WILLIAM ST.,  
NEW YORK CITY.

P. S.—Dealers will please apply for terms to Mallinckrodt Chemical Works, St. Louis and New York, who will supply the wholesale trade.



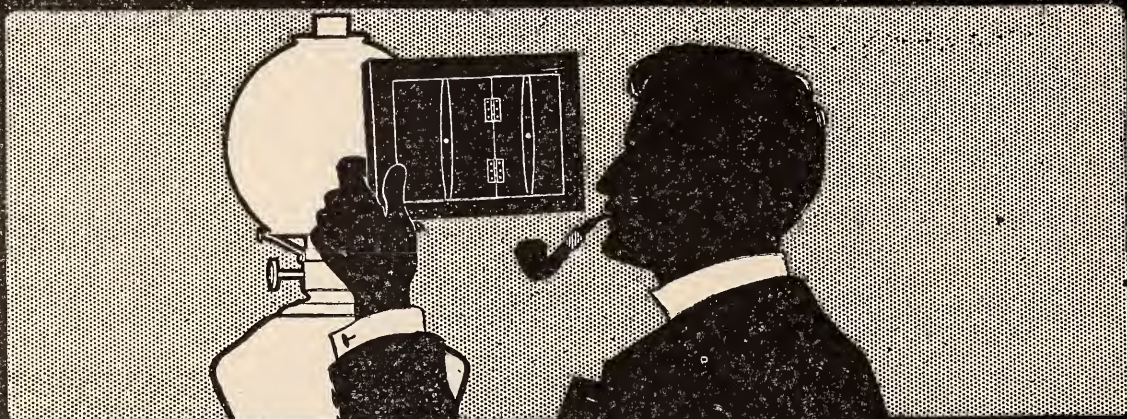

# VELOX

## Liquid Developer

Made especially for Velox by the Velox people—it makes Velox better than ever—and that is saying a great deal.

Four-ounce bottle Concentrated Solution, 25 cents.

ALL DEALERS.



NEPERA DIVISION,

EASTMAN KODAK CO.

ROCHESTER, N. Y.

## LUCK ON MUD MARSH.

On the 1st of October, 1901, Buck and I took the train for McKeever, N. Y., where we were met by our old guide and hunting companion, Jim T., and driven 10 miles to his house. It seemed as if our heads had hardly touched the pillow that night when we were being pulled out of bed by Jim. We slipped on our hunting togs and were soon on our way to the marsh. Jim's setter scared up 2 birds, one of which Buck secured with his 12 gauge Parker. As his gun went off, a ruffed grouse flew out of a bush near and I killed it. Then we separated, I going to a slight eminence on which were a few trees. In a short time I heard a loud rustling and the air was filled with grouse. I fired, getting a bird, and another with the second barrel. Reloading quickly, I got 2 more and would have killed others had I not remembered the teaching of a certain red and yellow covered magazine that I swear by. Picking up the birds I joined my friends. Jim had secured 3 and Buck 4, making 11 birds among us.

T. H. Leake, Menando, N. Y.

Received the Bristol steel rod. It is all right, both from æsthetic and practical standpoints. It is without doubt the best and cheapest thing I have ever owned in this line, and the work of securing subscriptions for it was one of the easiest tasks I have ever had, considering the generous remuneration.

A. M. Bowman, Camp Hill, Pa.

## WANT A REEL?

You can get one for nothing.  
Or at least for a few hours' work.

Send me

15 Yearly Subscriptions  
to  
**RECREATION**

and I will send you

**A TALBOT REEL**

Listed at \$20.00

Made by W. H. Talbot, Nevada, Mo.

This is one of the finest pieces of fishing tackle ever made. It is built like a gold watch. Equal to any Kentucky reel you ever saw.

**In Tournaments, Always a Victor  
Among the Angler's Treasures, Always the Chief**

I have but a few of these reels in stock and this offer will be withdrawn as soon as the present supply is exhausted.

Sample copies of RECREATION for use in canvassing furnished on application.

**Photographic Perfection**

is attained by making your negatives on

**ANSCO:** THE NEW DAYLIGHT LOADING FILM  
and your prints on

**CYKO:** THE PAPER THAT PRINTS AT NIGHT

ANSCO and CYKO have no peers in Keeping Quality and in Latitude of Exposure and Development.

Trial Dozen 4 x 5 CYKO and Developer, 20 cents.

ANSCO films are made under the celebrated Goodwin Patent and are adapted for Kodak's, Bull's-eyes and all Film Cameras.  
CYKO Manual and ANSCO Booklet sent on application.

**THE ANTHONY & SCOVILL CO.**

122-124 Fifth Ave., New York. Atlas Block, Chicago



From daylight to candle-light you are sure of twelve perfect prints from each dozen sheets.

PRICES:

4 x 5, 15c. doz. 6½ x 8½, 55c. doz.

5 x 7, 30c, " 8 x 10, 70c. "

If you want the best bromide paper, buy "Rotograph."

Sample copy of the Photo Critic, containing every month articles on "The A to Z of Photography." Of interest to amateur and professional. Sent on request.

Subscription \$1 per year. Write

**ROTOGRAPH**

Dept. V 101 Fifth Avenue, - N. Y. CITY

## A MIX UP WITH A GAME HOG.

BILL BROKENOSE.

I keep a sort of hotel at Frog Holler. Mebbe you've heard of it. Lots of fellers come to my place a sportin'. Any time you want to try it, jest foller Bullpout creek, South from the road, till you come to Pollywog pond. Then you'll see my hostillery. You can't miss it 'cause you'll have to come through my garden spot and you'll hear me a hollerin' to you to git out.

Last fall 2 fellers came down and said they would like to stay a couple of weeks a huntin' and a fishin'. I told 'em they could stay as long as they could pay. They said that was all right and to let 'em know when the time was up. They had the biggest lot of guns and truck I ever seen.

Next mornin', when they was goin' a huntin', one of 'em sez, "Do you like Maggie Zenes?"

I told him I didn't know any woman by that name.

"Who's talkin' 'bout women?" sez he. "I've got some old maggie zenes in my trunk and p'raps you might like to look at 'em."

Then I remembered that a maggie zene was a part of a gun. I didn't know just what part, but I'd heard fellers talk about emptyin' 'em at a deer. So I sez, "Well, if they ain't loaded I'll look 'em over for you and p'raps ile 'em up."

The feller went in the house and brought out 2 or 3 books, and gave 'em to me and sez, "I think you will like these."

"But," sez I, "where is the maggie zenes?"

"You've got 'em in your hand," he sez.

"What are you tryin' to stuff me with?" sez I, gettin' my dander up. "Don't you suppose I know a book from a maggie zene?"

They both luffed and went off without sayin' nothin', but they couldn't josh me, nohow. So I sot down to look at the books. They was the RE-CREATIONS and I liked 'em first rate. There was bully pictures in 'em of birds and animals, and there was one fine picture of a man with a big pile of fish. I bet there was over 200 of 'em. Gee whillikins! the feller was lucky if he wasn't han'some. A'cordin' to the book his name was A. Western Shoat.

It took me nearly a week to read them books, but I read every word in 'em. In one it said there was a game hog a ravagin' the country, and I thought if the fellers could only kill it it would make a diffence in the grub. They had been gittin' only deer, and hog meat would have tasted good after so much deer. I spoke to the fellers about it and they winked at each other and luffed, and said they wished they could run across that hog. But they didn't git it

One Sunday mornin' the fellers started out, but pretty soon they came back and

stood their guns against the house and said they wouldn't go a shootin' till afternoon. They hadn't killed nothin' for some time and meat was gettin' scarce. I kept thinkin' about that hog and how mighty fillin' he'd be for dinner. At last I took one of the guns without the fellers knowin' it, and went out the back way with my mind made up to find that hog.

I knew a spot about a mile off that I thought was a good enough rootin' place for any hog, and I went there. I got to where I was headin', in due season, but I couldn't find no hog. I hunted all around without findin' him till I thought it was time to be gittin' home. I was almost back when I heard a most awful scratchin' and a tearin' in the bushes close to me. There was a big log right handy, and I got behind it kind of quick. I just had time to shove the gun across the log to'ards the noise when out rushed somethin' as big as a horse and a comin' right for me. I didn't lose no time pullin' the trigger, and jest then somethin' hit me plumb in the face and knocked me 5 feet and over. I don't know to this day if it was the hog or if I was hit by lightnin'. I thought my time had come anyway, so I just lay still and shut my eyes and said prayers. Before I got to amen somethin' began to bark like all creation. I was curious to know what kind of a hog could bark, so I opened my eyes a bit. Darn me if there was any hog there; nothin' but my old dog Toze, a barkin' for keeps. I reckon he'd drove the critter away.

Well, my face was all covered with blood and my nose was so sore I couldn't touch it. Thinks I, "that's enough huntin' for me," so I picked up the gun and went home. The fellers was astandin' outside and they asked me what was the matter. I told 'em I'd been a huntin' that game hog.

"Did you find it?" sez they.

"I did, you know," sez I, "and I wisht I hadn't."

They luffed and sez if I couldn't do better than that I'd better quit huntin'. One of 'em told me my nose was broke and that the gun kicked me; they thought they could stuff me; jest as if I didn't know that a gun hasn't any feet to kick with.

That was the last time I went a huntin', but I'm willin' to cook game if other fellers will bring it in. If ever you want to come here to hunt jest let me know, Mebbe you could find that hog; he is too game for me. I like your book and would send you \$1 for it, only I forgot to tell those fellers when the time was up and they went away without paying me.

Captain—What is strategy in war? Give me an instance of it.

Sergeant—Shstrategy is whin ye don't let the enemy dishcover that ye'r' out of ammunition, but kape roight on foirin'.—The Moon,

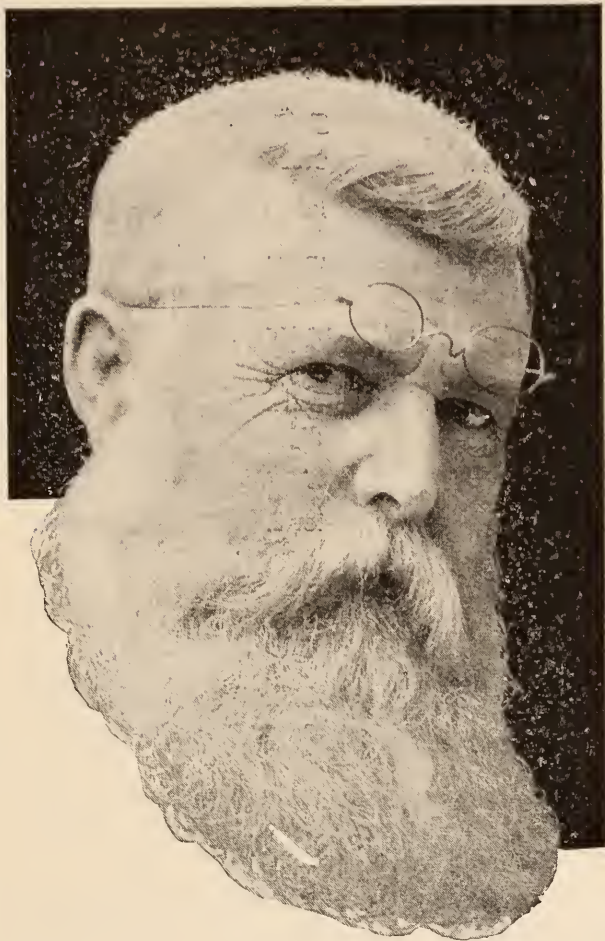

# SAVING UP FOR OLD AGE

MONEY NOT THE ONLY  
THING TO PUT BY.

**P**OVERTY in old age is pitiable, but how much sadder is broken health. Proper food in youth insures health in old age. But if the body is sluggish with wrong food or drink, good health cannot result. Many are wise with money but wasteful of health.

You cannot save money if you squander it nor save health if you waste it. More health is wasted on improper food and drink than in any other way. Coffee and tea contain strong drugs that directly affect the heart and other organs and the nerves. They have ruined many, and hurt nearly all who drink them. Sometimes coffee tears down tissue so rapidly that its ill effects are shown almost as soon as drinking it is begun. In others, it works so slowly that years pass before collapse. In a few, it apparently works no harm, and these are held up to the world by the unthinking as proof positive that "Coffee does not hurt."

Wrong nine times out of ten, for not more than one person in ten can drink coffee and not suffer. To prove this, see how many coffee drinkers you can find who are perfectly well. Maybe you have tried to stop and failed, because there are two ways and you tried the wrong one.

Get a package of **POSTUM FOOD COFFEE** (which is made from the purest cereals) and carefully read directions. Make it strong, boil it thoroughly, serve it hot, It is then a rich seal brown. Add sugar and cream and it becomes a tempting golden brown in color. The aroma is appetizing, so is the taste. It does not taste exactly like coffee. The flavor is original, and you will soon grow to like it for this. You can drink it at all meals, certain that it will give you health, strength and vigor. It will steady and quiet your nerves and induce sweet natural sleep, not from any drug, but from food which Nature calls for and is quiet when supplied. That's why a well-fed baby sleeps well.

Coffee injures nine out of ten.

POSTUM positively does restore health and vigor to the nervous coffee wreck.

There is a reason.



## Club Cocktails

Famous the world over for purity. They never vary. The secret of their perfect blend is that they are kept six months before being drawn off and bottled. Be sure you have them in your camp, on the yacht, and on your outing trips wherever you

go. They are ready and require no mixing. Simply pour over cracked ice.

For Sale by all Fancy Grocers and Dealers

**G. F. HEUBLEIN & BRO.**  
29 BROADWAY, N. Y. HARTFORD, CONN.

## Hotel Lenox

Boylston and Exeter Sts.  
BOSTON, MASS.

250 Rooms, 125 Baths.

All with Outside Exposure  
Fireproof. European Plan.  
Long Distance Telephone  
in every room.

Five minutes to the heart  
of the business, amusements  
and shopping districts.

**Ainslie & Grabow**  
PROPRIETORS

## DO YOU WANT A LENS?

If so, why not get a good one?  
And why not get it free of charge?  
This is easy.

Any old box will answer the purpose if it does not leak light; but you must have a fine lens to make a fine picture. You can get

### A Royal Anastigmat Lens, 4 x 5, Series No. 1

Made by the Rochester Lens Co., Rochester, New York,

And listed at \$45,  
For 20 yearly subscriptions to RECREATION

You can get any other lens made by this Company on a basis of one subscription to \$2. of the list price of the lens.

Sample copies of RECREATION for use in soliciting furnished on application.

### EXTRAORDINARY OFFER.

To any person sending me \$1 for a year's subscription to RECREATION, I will give free one of the following books: 6th and 7th Books of Moses. This is a great book. Every home should have one. Volumes I.-II., bound together in one volume; regular price is \$1. "The Almighty Dollar" is a new book just published, and is worth its weight in gold to any one. Can not be obtained for less than \$1 anywhere.

"Hunter's Guide and Trapper's Companion." This is a book every hunter and trapper should have. Descriptions of these books will be sent for a stamp. This is the greatest offer ever made, and you should not let this pass. Old subscribers may avail of this offer by sending 10 cents extra. Address Henry Nelson, Eckwoll, Minn.

Allow me to congratulate you on your success in bringing so large a share of Nature's gifts, her freedom, pure air, and warm sunshine, and her rarer gifts hidden from all save those who have made her their boon companion and guide, into the dreary, dusty offices of the city. One can not read your charming magazine without feeling in a measure the same delightful thrills that filled his whole being when as a boy he grasped his gun or rod and stepped out into the sunshine for his weekly half holiday. A half hour among its pages is indeed recreation.

T. W. Burgess, Springfield, Mass.

# Nothing Secret about Orangeine Powders—

*Its composition is as open as its results are prompt,  
and is published in direction booklet in every package.*

**NOTE** The varied and numerous uses of Orangeine have been evolved "by Humanity for Humanity," and its wide claims would seem ridiculous were they not suggested and sustained by countless human experiences.

## The Principle of Orangeine.

Orangeine combines both schools of medicine, and illustrates the following great principle now advocated by all progressive physicians, viz.: *The concerted, concordant action of remedies skillfully selected and combined, is vastly greater than the action of the same remedies, alternately prescribed.*

## What Orangeine is Doing for Humanity.

Orangeine supplies almost instant relief from pain, prompt correction for the little ills which lead to serious ailment, and a gradual, far reaching reconstructive power from extreme physical debility, and the stubborn symptoms which cause chronic ailments.

## Orangeine Applications Widely Demonstrated.

Heat Prostration,  
Stomach Upsets,  
Bowel Troubles,  
Indigestion,  
Dyspepsia,

Headache (all kinds)  
Neuralgia,  
Nervousness,  
Sea Sickness,  
Car Sickness,

Hay Fever,  
Asthma,  
Colds,  
Grip,  
Fatigue,

*and a host of common ailments.*

## Orangeine Dispels Hay Fever.

During the past five years, Orangeine has made a phenomenal record for the relief of Hay Fever, in even most stubborn and long continued cases. Thousands of former sufferers have, through Orangeine, found immunity which they could not find at any Hay Fever resort, and our advice has been everywhere confirmed to Hay Fever sufferers, to "Stay at Home or Go Anywhere," provided they TAKE Orangeine, under our simple directions.

## A Few Suggestive Experiences.

Mr. J. A. Waldron, Managing Editor of *The New York Dramatic Mirror*, says: "I am not only a steady user of 'Orangeine' Powders, being of an age when their singular and admirable stimulating powers prove very beneficial, and being also subject to Hay Fever in summer and Grip in winter; but I have formed the philanthropic habit of dispensing them to friends, for various temporary ailments which 'Orangeine' so accurately reaches.

"From my experience, I predict that the wonders of 'Orangeine' are yet in their infancy."

P. J. Cunningham, Leslie, Mich., writes: "'Orangeine' is the only remedy that has given me any relief from 'hay fever,' and I have tried a great number."

Mr. Frank T. Bliss, of Morris, Ill., describes his experience: "I have been a sufferer from hay fever for over twenty years, have tried every remedy obtainable, but until this year I have been compelled to spend the hay fever season in northern Michigan. I have been enabled to stay at home this year with perfect freedom from this dread disease by using 'Orangeine' powders as directed."

Mr. O. J. Carpenter, Killduff, Ia., writes: "'Orangeine' has certainly helped me. Have been using it for 'hay fever.'"

Miss Nella Miles, Stockton, N.Y., writes: "I find 'Orangeine' very good for 'hay fever.'"

Miss Hattie McClelland, Madison, Ind., writes: "Have taken four powders a day, and am getting along fine. Have had only slight attack of 'hay fever' so far, and am perfectly free from it to today, something that has never happened before at this season of the year."

Mr. Conrad Rockel, Dallas City, Ill., writes: "'Orangeine' is doing me much good. I think two boxes more will keep 'hay fever' off entirely."

Mrs. I. E. Lansing, Marshall, Mich., writes: "I find it the best thing I ever tried, and I have tried everything."

Miss Bernice Dutton, Little Rock, Ark., writes: "Orangeine makes one feel more like working. More like living. The powders are so simple, so easy to take, so convenient to carry, and yet so effective."

**Trial Package Free** Orangeine is sold by druggists everywhere in 25c, 50c and \$1.00 packages. On receipt of request we will mail 10c trial package Free with full directions, composition and description of its wide human influences. Address "**Orangeine, Chicago.**"

In happy homes, wherever found,  
One hears the Washburn's merry sound

## THEY PLAY WASHBURN



## MANDOLINS GUITARS AND BANJOS.

Unequaled for Tone, Durability  
and Workmanship.

We will gladly send free a beautiful Art Souvenir Catalogue and "Facts About The Mandolin" and "How to Play The Mandolin" if you will send us your address on a postal card.

**LYON & HEALY,** 28 Adams St.,  
Chicago.  
The World's Largest Music House. Sells "Everything Known in Music."



**ARNICA**  
*Tooth Soap*  
*the International Dentifrice*

Beautifies the teeth, hardens the gums, sweetens the breath. Preserves as well as beautifies the teeth. Comes in neat, handy metal boxes. No powder to scatter, no liquid to spill or to stain garments.

25 Cents  
At all Druggists.  
C. H. STRONG & CO., Proprietors,  
Chicago, U. S. A.

I received the Harrington & Richardson revolver you sent me as a premium. Am well satisfied and thank you for it.

I. W. Marsh, Hunter, N. Y.



## Music Boxes

For the Home, it is come pany at all times, will cheer you when you are sad; a veritable need when you are lonely; an accompaniment to your song, and play **Dance** music in **perfect time**. A boon to all music lovers. Our variety is great; prices to suit all. Our No. 20 costs only \$2.50, while our No. 191 runs in the hundreds. Complete Catalogues FREE.

**E. L. CUENDET, 7 Barclay St., New York**

## DOMER GOES A-FISHING.

L. S. P.

Had I the talent of ancient Homer,  
I'd sing of Willie Domer,  
And set all the sporting men to wishing  
They to the river could go a-fishing.

And yet this same redoubtable Domer  
This rancorous, rampant, roaring roamer,  
While fishing out at Dickerson Station  
Was matched by a turtle and lost his ration.

This sad event, says Mrs. Grundy,  
Fell to the lot of William last Sunday:  
He caught his fish, it was a whopper,  
And put it away where he thought proper.

He put it into a little pool  
And hunted a drink of "something cool."  
The boys all told him, "Better look out,  
A turtle is sure to eat that trout!"

"Who's boss of this fish?" our Willie said;  
"Go hang up your jaw and soak your head;  
You don't know what you are talking  
about;  
I'll swallow the turtle that eats my trout!"

Long tarried our Willyum with his lunch,  
Till the other fishermen caught their bunch;  
Then he calmly looked for the fish he'd  
caught,

'Twould lay the rest in the shade, he  
thought.

Great Cæsar! You ought to have seen his  
frown;

A turtle had gobbled his big fish down;  
There wasn't a scale nor a piece of fin  
To show where our Willie's fish had been.

Raw turtle on toast! Stand up to the rack,  
Stick to your contract and commence the  
attack;

"You said you'd swallow it, don't back  
out,"

Said the crowd to the man who caught the  
trout.

And that is why our Willie swears  
That to go a-fishing he no more cares;  
There's chills and fever up the Potomac,  
And turtle that's raw ain't good for the  
stomach.

Judge—What is your profession?

Witness—I'm a poet, your Honor.

Judge—That's not a profession; it's a  
disease.—Exchange.



# Free! TWO SPLENDID BOOKS FOR Free!

## ==== Hunters, Sportsmen, Campers Out, Etc. Etc. ====

Fairly bristles with facts and information from start to finish. **Two** complete up to-date volumes, entirely covering the subject of "Camping Out and Outfits."

Pronounced by the very best authorities the most practical work ever published on the subject.—A Handsome volume.

Glitters with Pictures  
from Cover to Cover

196 PAGES. In all  
over 200 Illustrations

Bound in Linen, 5 Col-  
or Covers

Size, 6½ x 4½ inches

**FREE!**

Brimfull of brainy facts exhaustively covering every subject from A to Z, interesting and of instructive value and service to every sportsman and camper out, old or young. We have thousands of letters from all over the World (some from noted sportsmen),

who congratulated us upon these books. Contains a thousand facts of value never before put in print, and there is scarcely a campaigner *anywhere*, no matter how old or experienced he may be, who cannot learn something from these books. They are better than some books sold at \$1.00 a copy.

**They are Free to You** on receipt of 10c., coin or stamps to cover cost of mailing them to you. Address.

If you be wise write at  
once for these books;  
they'll surprise you

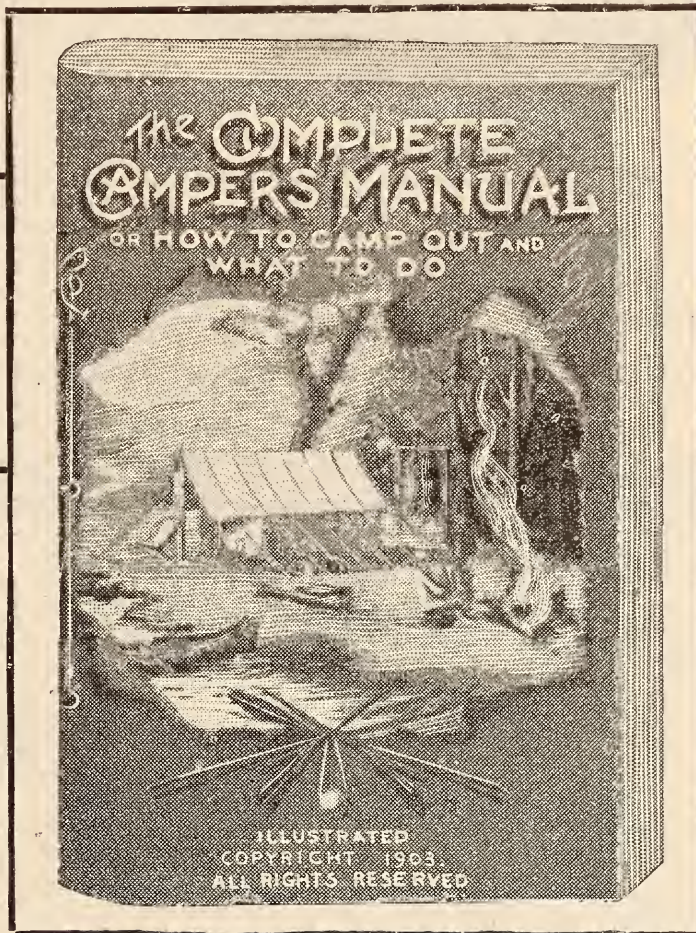

**“Buzzacott” Dept. A**  
**COMPLETE CAMP OUTFITTER**

Racine Junction, Wis. or Chicago, Ill., U. S. A.

Mention RECREATION.



**H. J. TILLOTSON, M. D.**  
 The Master Specialist of Chicago, who Cures Varicocele,  
 Hydrocele, and treats patients personally.  
 Established 1880.  
 (COPYRIGHTED)

# Varicocele Hydrocele

**Cured to Stay Cured in 5 Days.  
 No Cutting or Pain. Guaranteed  
 Cure or Money Refunded.**

**VARICOCELE.** Under my treatment this insidious disease rapidly disappears. Pain ceases almost instantly. The stagnant blood is driven from the dilated veins and all soreness and swelling subsides. Every indication of Varicocele vanishes and in its stead comes the pleasure of perfect health. Many ailments are reflex, originating from other diseases. For instance, innumerable blood and nervous diseases result from poisonous taints in the system. Varicocele and Hydrocele, if neglected will undermine physical strength, depress the mental faculties, derange the nervous system, and ultimately produce complicated results. In treating diseases of men I always cure the effect as well as the cause. I desire that every person afflicted with these or allied diseases write me so I can explain my method of cure, which is safe and permanent. My consultation will cost you nothing, and my charges for a perfect cure will be reasonable and not more than you will be willing to pay for the benefits conferred.

**Certainty of Cure** is what you want. I give a legal guaranty to cure or refund your money. What I have done for others I can do for you. I can cure you at home.

**Correspondence Confidential.** One personal visit at my office is preferred, but if it is impossible for you to call, write me your condition fully, and you will receive in plain envelope a scientific and honest opinion of your case, Free of charge. **My home treatment is successful.** My books and lectures mailed free upon application.

**H. J. TILLOTSON, M. D., 140 Tillotson Bldg, 84 Dearborn St., CHICAGO**

## FREE BOOK, WEAK MEN



My illustrated nature book on losses varicocele, impotency, lame back, free sealed, by mail. Much valuable advice and describes the new **DR. SANDEN HERCULEX ELECTRIC BELT.** Worn nights. No drugs. Currents soothing. Used by women also for rheumatic pains, etc. 5,000 cures 1902  
 Established 30 years. Advice free.

**DR. G. B. SANDEN,**  
 1155 Broadway, N. Y.

**The Best Offer Yet.**—To any person who will subscribe to *RECREATION* for one year through me I will send free a small water color landscape, hand painted, suitable for framing; or a hand painted silk bookmark. For two subscriptions I will send a fine Mexican opal scarf pin worth ordinarily from \$1 to \$1.50.

Doi M. Harris, 308 Crawford Road,  
 Cleveland, Ohio.

Do you want a Good, Reliable,  
 Substantial, Well Made

## Single Barrel Shot Gun

If so, send me

**10 YEARLY SUBSCRIPTIONS**

and I will send you such a  
**Gun as a premium**

It is made by the *DAVENPORT ARMS CO.*, and this means it is made of good material and that only good workmanship is put on it.

This is one of the many remarkable opportunities *RECREATION* is offering to men and boys to fit themselves out completely for shooting and fishing.

Sample Copies for Use in Canvassing  
 Furnished on Application.

Address

## RECREATION

23 W. 24th St., New York City

IF YOU WOULD LIVE NEXT TO  
 NATURE, READ RECREATION.

**MENNEN'S BORATED TALCUM**

TRADE MARK

**TOILET POWDER**

A Positive Relief For  
**PRICKLY HEAT, CHAFING, and SUNBURN,** AND ALL AFFLICTIONS OF THE SKIN.

"A little higher in price, perhaps, than worthless substitutes, but a reason for it." Removes all odor of perspiration. Delightful after Shaving. Sold everywhere, or mailed on receipt of 25c. Get Mennen's (the original). Sample Free.

**GERHARD MENNEN CO., Newark, N. J.**

# If Water Would Cure

aches and pains; heal cuts and bruises; subdue inflammation, hemorrhages, soreness, lameness, scalds, burns, insect bites and stings, sunburn, neuralgia and rheumatism, POND'S EXTRACT would never have gained its world wide fame as "King" of pain cures. For 60 years it has been alleviating pain of all kinds.

Don't be misled by the claim that POND'S EXTRACT is the same as witch hazel. POND'S EXTRACT CURES. Ordinary witch hazel is practically all *water*—that's *why it WON'T* cure. That's why you can get so much for so little—water is cheap. Insist on POND'S EXTRACT—the true extract of *Hamamelis Virginica* and accept no other. The true cure for all pain.

Sold only in sealed bottles, enclosed in buff wrappers.

**To RECREATION Readers:** I am organizing a club of subscribers for RECREATION, with a view to securing a premium, and I submit this offer; to each person sending me \$1 for yearly subscription to RECREATION, I will send a 25c. Dominion of Canada bank note. There are but a few of these in circulation and I have succeeded in collecting a number of them. These are interesting souvenirs and are especially valuable to persons who are making collections of coins or other curios. Walter Legare, 518 John St., Quebec, Can.

Three years ago I bought a Marlin 22 caliber, take down, pistol grip gun. As long as I held the barrel level, things went nicely, but the instant I elevated the barrel it stuck. I finally traded it, with \$8 to boot, for a Winchester take down. I also owned a Marlin shot gun, and would consider the gift of another an insult. My advice to all inquirers is: Buy any old muzzle loader rather than a Marlin.

As to Peters ammunition, I hope I may shoot myself with the next I buy.

C. S. Scribner, Dayton, O.

## LEAVE A KNIFE BEHIND YOU



48c.



for your Guide or Host or Boatman; he will think of you longer than if it was a \$10 bill. If "Maher & Grosh" is on the blade he knows the quality. Deal direct with us and get our best service. This cut is "Chauncey Depew's Pet," has three blades (one is a file). Handle is choicest selected pearl; German silver back and ends. Price, in chamois case, \$1.50, postpaid. Same knife, 2 blades, \$1; plainer finish, 3 blades, same quality, \$1; smaller, 2 blades, for lady, \$1; plainer finish, 75 cents; **Razor Steel Jackknife**, 2 blades, price 75 cents, but 48 cents for a while; 5 for \$2. This knife and 60 cent shears for \$1. Hollow ground Razor, Strop and Brush, \$1.33. Illustrated 80-page list free, and "How to Use a Razor."

Be kindly; write us.

**Maher & Grosh Co.**  
74 A Street Toledo, Ohio

# ANOTHER GREAT OFFER TO AMATEUR PHOTOGRAPHERS

A 4 X 5 SERIES 1 KORONA CAMERA  
LISTED AT \$12, FOR 8 YEARLY SUBSCRIPTIONS TO *RECREATION*;

A 5 X 7 SERIES 1 KORONA CAMERA  
LISTED AT \$16, FOR 12 YEARLY SUBSCRIPTIONS;

A 4 X 5 SERIES 2 KORONA CAMERA  
LISTED AT \$18, FOR 14 YEARLY SUBSCRIPTIONS;

A 4 X 5 SERIES 3 KORONA CAMERA  
LISTED AT \$22, FOR 18 YEARLY SUBSCRIPTIONS;

A 4 X 5 SERIES 4 KORONA CAMERA  
LISTED AT \$25, FOR 20 YEARLY SUBSCRIPTIONS;

A 4 X 5 SERIES 5 KORONA CAMERA  
LISTED AT \$35, FOR 30 YEARLY SUBSCRIPTIONS.

*SAMPLE COPIES, FOR USE IN CANVASSING,  
FURNISHED FREE.*

A D D R E S S

R E C R E A T I O N

23 WEST 24TH STREET, NEW YORK CITY



# Pabst

brews beer to suit the popular taste; some light and some dark, but all absolutely pure. It's not an experiment, but an assured fact, and thus the widespread popularity of Pabst Blue Ribbon is explained.



A Delicious "Smack"  
follows every taste of  
**ALPHA**  
New England  
Salad Cream

the ideal Salad Dressing and Table Sauce. Perfects any dish. **CONTAINS NO OIL**, but if desired you can add your favorite brand of oil.

Try **ALPHA** on salads, fish, baked beans, cold meats, cucumbers, sliced tomatoes, lettuce, etc. **ALPHA** is the most welcome condiment ever placed on your table. Healthful. Preferred to catsup. Suits everybody. Creates appetite. Aids digestion. Every bottle guaranteed absolutely pure. **NEVER, NEVER SPOILS.** Your money back if you don't like it. **AT ALL GROCERS.**

**Martha Taft Wentworth** Recipe Book (60 Recipes and Suggestions) sent free for grocer's name.  
**THE H. J. BLODGETT CO. (Inc.) 67 Thayer St., Boston, Mass.**

Also Manufacturers of **WONDERLAND PUDDING TABLETS**  
One tablet makes a quart of milk into a milk jelly more delicious, refreshing and nourishing than other desserts. **ALSO MAKE DELICIOUS ICE CREAM.** Package of 10 Tablets by mail 10c. No samples.

**The Best Yet:**—To any person sending me \$2, express or money order, for one year's subscription to **RECREATION**, I will give free, one fine 3 joint bamboo rod, 7 to 9 feet long, one nickel plated 60 yard multiplying reel, and 50 yards of waterproof silk line. This outfit, including **RECREATION**, would cost \$6. Or I will give the above outfit for 7 yearly subscriptions to **RECREATION**. Or I will give the 50 yards of silk line, listed at \$1, for one subscription and 25 cents extra. This line is a very fine outfit and would retail in any store at \$1.  
C. W. Jacobs, 339 N. 2nd St., Coshocton, O.

# Here is Another!

If you will send me

30 Yearly Subscriptions

to

# RECREATION

I will send you

## A No. 10 Goerz Trieder- Binocular Field Glass

Listed at \$38.00

Every well-informed man knows the great power of this modern prismatic field glass. It is indispensable to every hunter, and is one of the latest and best on the market.

I have but a few of these instruments on hand and the offer will be withdrawn as soon as the supply is exhausted. Therefore, if you want one

**START IMMEDIATELY.**

Sample copies of **RECREATION** for use in canvassing furnished on application.

Briggs—Do you consider Mercer a good French scholar?

Griggs—Fair. He understands the language sufficiently well not to attempt to speak it.—Boston Transcript.

"See here, you chump, I placed an ad in your paper, showing the public how to get rich quickly, and you place underneath it another ad on 'how to cure the dope habit.'"—Brooklyn Eagle.

The  
Hawkeye

## REFRIGERATOR BASKET

**IDEAL FOR ALL OUTINGS**

Lined with zinc, hair, felt and asbestos. Airtight and dust-proof. A small quantity of ice



keeps contents deliciously cool and sweet throughout the warmest Summer day. Light, compact and durable. Your money back if not pleased after ten days' trial.

No. 1, size 18x10x8 inches deep, . . . price, \$3.25

No. 2, size 20x13x10 inches deep, . . . price, \$3.50

Ask your dealer for it, or will send C. O. D. subject to inspection. Write to-day for booklet giving full description.

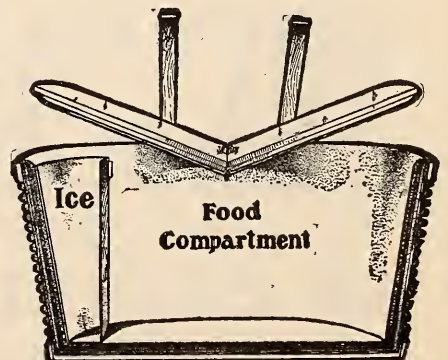

**BURLINGTON BASKET WORKS, 17 Main St., BURLINGTON, IOWA**

## A Most Delicious Dessert

*Shredded Whole  
Wheat Biscuit* is made in the most hygienic and scientific food laboratory in the world. The wheat is spun into light shreds, containing thousands of open pores and is not crushed flat and dense as in case of other foods. These pores absorb the digestive juices and provide far greater surface for their action than is given by any other food.

The following simple "course before coffee" is much in vogue with club men everywhere. The simplicity of preparation and the little cost, together with the delicious taste of the composes, make this dessert in rare favor in the home.

Use Seasonable Fruit and

# SHREDDED WHEAT BISCUIT



How to  
Split the  
Biscuit

Split and slightly toast the Biscuit, then serve with berries, sliced peaches, bananas or any seasonable fruit. Simple, isn't it. Your verdict will be

**"Simply Delicious."**

**FOR SHORTCAKE**—With sharp knife halve the Shredded Whole Wheat Biscuit lengthwise, prepare pineapple as for sauce (or bananas or mixed fruit) and set aside. When serving arrange halves in layers covered with fruit and add sugar and whipped cream.

Shredded Whole Wheat Biscuit is Sold by All Grocers.

Send for "The Vital Question" (Recipes, illustrated in colors) FREE. Address

**The NATURAL FOOD CO., Niagara Falls, N. Y.**

**Free**—To each person sending me \$1 (post-office money order) for one year's subscription to RECREATION, I will send choice of a Braided Leather Dog Whip, with a steel snap on end, on a Polished Steel Dog Chain, with swivels, snaps, etc., or one dozen assorted Trout Flies, silk bodies, good ones, or a Pocket Compass, one inch dial, open face, watch shape, with ring handle and bevel crystal. Also a special offer limited to the months of June, July, August and September of a nickel plated multiplying 40 yard raised pillar reel, balance handle with click, drag and free running for two subscriptions. For four subscriptions a genuine 6 strip Split Bamboo or Fly Rod, 4 pieces with grips, silk whipped, nickel plated mountings, solid metal reel seat, length about 9½ feet.

Edward S. Adams,  
Box 536, Manchester, N. H.

Am a regular reader of RECREATION and it is absolutely the best sportsman's periodical I ever had the privilege of reading. Having been brought up in nature's best school, the farm, and being now engaged in inside work, RECREATION is like a wave of clover-scented air to my tired brain. Your March number is fine. I have reread it, advertisements included, no less than 4 times.

L. J. Tooley, Kalamazoo, Mich.

## AS AN AID TO DIGESTION

No seasoning can compare with  
**McILHENNY'S**

### Tabasco Sauce

It is purer and more healthful than ground pepper, and leaves no lumps or sediment.



gives a delicious and spicy flavor to  
**SOUPS, SALADS, OYSTERS, CLAMS, FISH,  
LOBSTERS, CHOPS, ROASTS,  
SAUCES, GRAVIES, Etc.**

Be sure to ask your dealer for McILHENNY'S

### Tabasco Sauce

the original and best. Once used, TABASCO SAUCE becomes a household necessity.

**FREE** We will gladly send, upon request, an interesting booklet with many new and unique recipes.

Address

**McILHENNY'S TABASCO, NEW IBERIA, LA.**

## SOME RARE OPPORTUNITIES

These goods are all new, and will be shipped direct from factory. Prices named are those at which manufacturers and dealers usually sell. Here is a good chance to get

A Book, a Gun, a Camera  
A Sleeping Bag, a Fishing Rod  
A Reel, a Tent, } FREE OF COST

Subscriptions need not all be sent at once. They may be sent in installments as taken and credit will be given on account. When the required number is obtained the premium earned will be shipped.

**These Offers are subject to change without notice.**

**TO ANY PERSON SENDING ME**

TWO yearly subscriptions to RECREATION at \$1 each, I will send a copy of *Hunting in the Great West*, cloth; or a Zar Camera, listed at \$1; or an Ingersoll Watch or Cyclometer, listed at \$1; or a Recreation Waterproof Match Box, made by W. L. Marble and listed at \$1; or a Shakespeare Revolution Bait listed at 75 cents; or a Laughlin Fountain Pen; or a dozen Trout Flies, assorted, listed at \$1; or a pair of Attachable Eyeglass Temples, gold-plated, made by Gall & Lembke; or one Rifle Wick Plug, made by Hemm & Woodward, Sidney, Ohio, 30 caliber to 50 caliber, or Shotgun Wick Plug, 20 gauge up to 10 gauge.

THREE subscriptions at \$1 each, a safety pocket ax, made by W. L. Marble and listed at \$2.50; or a dozen Bass Flies, assorted, listed at \$2; or a pair of chrome tanned horsehide hunting and driving gloves, listed at \$1.50, made by J. P. Luther Glove Co.; or a pair of Shotgun Wick Plugs made by Hemm & Woodward, Sidney, Ohio, 20 gauge to 10 gauge.

FOUR subscriptions at \$1 each, an Ideal Hunting Knife, made by W. L. Marble and listed at \$2.50; or a .32 caliber Automatic Forehand Revolver, made by the Hopkins & Allen Arms Co.; or a No. 822 Rifle made by the Hopkins & Allen Arms Co., listed at \$4.50.

FIVE subscriptions at \$1 each, a copy of *Cruisings in the Cascades*, cloth; or a set of Nehring's Convertible Ampliscopes, listed at \$5.00; or an Ideal Hunting Knife made by W. L. Marble, and listed at \$3; or a polished Buffalo Horn Gun Rack, made by E. W. Stiles; or a Forehand Gun, made by the Hopkins & Allen Arms Co., listed at \$6; or a pair of lock lever skates, made by Barney & Berry, listed at \$4.50; or a pair of gauntlets, for hunting and driving, ladies' size, listed at \$2.50, made by J. P. Luther Glove Co., or a J C Hand trap made by the Mitchell Mfg. Co., listed at \$4.

SIX subscriptions at \$1 each, a Hawkeye Refrigerating Basket made by the Burlington Basket Co., or one dozen Eureka golf balls listed at \$4; or a Forehand Gun made by the Hopkins & Allen Arms Co., listed at \$9; or a Pocket Poco B  $3\frac{1}{4} \times 4\frac{1}{4}$ , made by the Rochester Optical & Camera Co. listed at \$9.

SEVEN subscriptions at \$1 each, a copy of *The Big Game of North America*, or of *The American Book of the Dog*, cloth, or one set Lakewood golf clubs, 5 in number, listing at \$5; or a series 11B or 11D Korona Camera, made

by the Gundlach Optical Co., listed at \$10. EIGHT subscriptions at \$1 each, a 4 x 5 Weno Hawk-Eye Camera, made by the Blair Camera Co., and listed at \$8.; or a series 1, 4x5, Korona Camera, made by the Gundlach Optical Co., listed at \$12.; or a pair of horsehide Hunting shoes, made by T. H. Guthrie, Newark, N. J., and listed at \$8.

NINE subscriptions at \$1 each, an Acme single shot gun, made by the Davenport Arms Co., and listed at \$8.

TEN subscriptions at \$1 each, a Cut-Glass Salad Bowl, made by Higgins & Seiter, and listed at \$4.50; or a Yawman & Erbe Automatic Reel, listed at \$6 to \$9; or a Bristol Steel Fishing Rod, listed at \$6, or less; or a Waterproof Wall Tent 7 x 7, made by Abercrombie & Fitch, and listed at \$8.; or a pair of horsehide Hunting Boots, made by T. H. Guthrie, Newark, N. J., and listed at \$10; or a Rough Rider rifle telescope, made by The Malcolm Rifle Sight Mfg. Co., and listed at \$12.

TWELVE subscriptions at \$1 each, a Peabody Carbine valued at \$12; or a Davenport Ejector Gun, listed at \$10., or a Cycle Poco No. 3, 4x5, made by the Rochester Optical and Camera Co., listed at \$15.

FIFTEEN subscriptions at \$1 each, a Shakespeare Reel, Silver Plated, listed at \$15; or a set of rabbit plates made by Higgins & Seiter, and listed at \$8, or a Field Glass made by Gall & Lembke; or a Kenwood Sleeping Bag, complete, with canvas cover, listed at \$16; or a Bulls-Eye rifle telescope, made by The Malcolm Rifle Sight Mfg. Co., and listed at \$16.

TWENTY subscriptions at \$1 each, a 14-karat Gold Hunting-case Watch, with Waltham Movement, listed at \$20; or an Elita single shot gun, made by the Davenport Arms Co., and listed at \$18., or an Acme Folding Canvas Boat, No. 1, Grade, A listed at \$27; or a Mullins Duck Boat, listed at \$20; or a Shattuck double hammerless shot gun listed at \$25; or a Pneumatic Camp Mattress, with pillow listed at \$20.

TWENTY-FIVE subscriptions at \$1 each, an 11-foot King Folding Canvas Boat, listed at \$38; or a 4 x 5 Planatic lens, made by the Rochester Lens Co., and listed at \$25; or a Syracuse Grade OO, double hammerless Gun, made by the Syracuse Arms Co., and listed at \$30.

THIRTY subscriptions at \$1 each, a Waterproof Tent,  $14\frac{1}{2} \times 17$ , made by Abercrombie & Fitch, and listed at \$25; or an Ithaca, quality No. 1, plain, double barrel, hammerless breech loading shot gun, listed at \$40.; or a Field Glass, made by C. P. Goerz.

THIRTY-FIVE subscriptions at \$1 each, a 14-foot King Folding Canvas boat, listed at \$48.

FORTY subscriptions at \$1 each, a Savage .303 Repeating Rifle; or a No. 10 Gun Cabinet, made by the West End Furniture Co., and listed at \$32.

FORTY-FIVE subscriptions at \$1 each, a Royal Anastigmat Lens, 4 x 5, series I, made by Rochester Lens Co., and listed at \$45.

FIFTY subscriptions at \$1 each, a No. 20 Gun Cabinet, made by the West End Furniture Co., and listed at \$38.

TWO HUNDRED subscriptions at \$1 each, a strictly first class upright piano, listed at \$750.

Address, **Recreation** 23 West 24th St.  
New York





## AUTOMOBILING

There is no more exhilarating sport or recreation than automobiling. The pleasure of a spin over country roads or through city park is greatly enhanced if the basket is well stocked with

## Dewar's Scotch

“White Label”

the popular brand both in this and the old country. “There is no Scotch like Dewar's,” is a proverb among connoisseurs.

### AN AUTOMOBILING POSTER.

“Automobiling” (copyright 1903, by Frederick Glassup) is an original drawing by E. N. Blue, shown herewith. Printed in four colors on heavy plate paper, without advertisement, and sent to any address on receipt of 10 cents in silver. Suitable for framing in club-house or home. Next month, a delightful camp scene by the famous artist, Dan Smith.

FREDERICK GLASSUP

*Sole Agent for John Dewar & Sons, Ltd.*

126 Bleecker Street, New York

## WANT A REEL?

You can get one for nothing.  
Or at least for a few hours' work.

Send me

15 Yearly Subscriptions

to

# RECREATION

and I will send you

## A TALBOT REEL

Listed at \$20.

Made by W. H. Talbot, Nevada, Mo.

This is one of the finest pieces of fishing tackle ever made. It is built like a gold watch. Equal to any Kentucky reel you ever saw.

**In Tournaments, Always a Victor  
Among the Angler's Treasures, Always the Chief**

I have but a few of these reels in stock and this offer will be withdrawn as soon as the present supply is exhausted.

Sample copies of RECREATION for use in canvassing furnished on application.



## UNDERWOOD'S ORIGINAL DEVILED HAM

The pure and delicate Deviled Ham which has been on the market for years. Sugar-cured ham and fine, pure spices is all that we use. It is delicious for sandwiches, at lunch, picnic, or tea, and in the chafing-dish. It may be bought at any good grocers, but be sure you see on the can THE LITTLE RED DEVIL. There is only ONE Deviled Ham—Underwood's Red Devil Brand. All others are imitations, but imitations in name only, as the goods commonly labeled and sold as potted or deviled ham, made as they are from the odds and ends of the packing house, are no more like Underwood's Original Ham than chalk is like cheese. Our Book contains a lot of unique and practical receipts. We will send it FREE. WM. UNDERWOOD CO., Boston, Mass., U. S. A.

# DIAMONDS ON CREDIT



## OUR NEW SPECIAL SUMMER CATALOGUE

EVERY person interested in Diamonds will want a copy of our **NEW SUMMER CATALOGUE**, for it shows the latest creations in artistic Diamond mountings, fine jewelry and watches. These new and fine goods you will not find illustrated in the catalogues of other houses until next fall, for we are the only house in the Diamond and Jewelry business which issues a complete catalogue between seasons. Everything illustrated is quoted at exceptionally low prices and sold on the **POPULAR LOFTIS SYSTEM** of easy payments. Select any article that you like and it will be delivered at your door with all express charges paid. Only one-fifth of the price need be paid at first; the balance being arranged in a series of small monthly payments extending over eight months. No security is required; no interest is charged and no publicity is created when you buy on our **CONFIDENTIAL CHARGE ACCOUNT SYSTEM**. If you make a selection, it will be upon the distinct understanding that your money will be promptly returned in case you decide not to purchase. We are the largest concern in the business and sell only the finest genuine goods, and at prices ranging from ten to twenty per cent below those of other houses. Every Diamond is sold under a written guarantee of quality and value and may be exchanged at any time in the future for other goods or a larger stone at the full original price. Our Confidential Credit System is open to all honest persons without regard to their financial worth; but if you prefer to buy for cash we make the most startling and liberal offer ever made. It is no less than guaranteeing the return of all money paid at any time within one year—less ten per cent, the reasonable cost of doing business. We are one of the oldest houses in the trade (Est. 1858). We refer to any bank in America—for instance, ask your local banker to consult his Dun or Bradstreet book of commercial ratings and he will tell you that we stand at the top in credit, reliability and promptness. We have a number of attractive booklets that we will be glad to send you if you write promptly for our New Summer Catalogue.

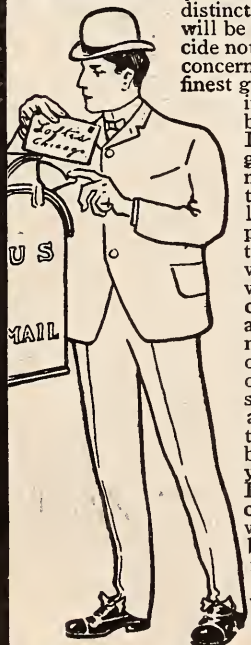

**LOFTIS BROS. & CO.**

*Diamond Importers and  
Manufacturing Jewelers*

Dept. G-32 92 to 98 State St. **CHICAGO, ILL.**  
Opposite Marshall Field & Co.

# Sent on Approval TO RESPONSIBLE PEOPLE Laughlin Fountain Pen

Guaranteed Finest  
Grade 14k.  
**SOLID GOLD PEN.**

To test the merits of  
**RECREATION**

as an advertising medium  
we make this grand special offer, your choice of

These  
Two  
Popular  
Styles  
For Only **\$1.00**  
Postpaid  
to any  
Address

(By Registered mail 8 cents extra)

Holder is made of finest quality hard rubber, in four simple parts, fitted with very highest grade, large size 14k, gold pen, any flexibility desired—in feeding device perfect.

Either Style—**RICHLY GOLD MOUNTED** for presentation purposes, \$1.00 extra.

## Grand Special Offer

You may try the pen a week; if you do not find it as represented, fully as fine a value as you can secure for three times the price in any other makes, if not satisfactory in every respect, return it and we will promptly refund your money.

Illustration on left is full size of Ladies' style; on right, Gentlemen's style. Lay this **RECREATION** Down and Write **NOW**.

Safety Pocket Pen Holder sent free of charge with each Pen.

ADDRESS :

**Laughlin Mfg. Co.**

424 Griswold St., DETROIT, MICH.



**ILLUSTRATING is a Money-Making**

profession. We teach you by mail to become an **Illustrator, Ad.-Writer, Journalist, Proofreader, Bookkeeper, Stenographer, Electrician, Electrical Engineer, etc.** Write for **Free** illustrated book, "**Struggles With the World,**" and mention the subject which interests you. **Correspondence Institute of America, Box 701, SCRANTON, PA.**



Trade Mark Registered.

**The Puritan Fountain Pen Filler**  
*Fills the pen with ink and the world with joy.*

Push the pen barrel on arm of filler and withdraw, and your pen is filled. No staining or bubbling. Desk form 25 cents. Pocket form 20 cents. Order of your dealer or by mail. Give inside diameter of pen barrel.

**Beekman Novelty Co.,**  
317 Broadway, New York City

I have become much interested in the discussion in RECREATION concerning the merits and demerits of the Marlin rifle and Peters' cartridges. The altercation brings to my mind an incident and suggests a few thoughts.

In October, '99, with 2 friends, I was hunting deer on Howe brook, about 6 miles East of St. Croix lake, Aroostook county, Maine. I carried a 38-55 Winchester, one companion had a 30-30 Winchester and the other a 30-30 Marlin. One evening the owner of the Marlin came into camp in a rage. He had jumped a small band of deer and fired one shot without apparent effect. The deer circled and came to a stop in plain view, with a big buck affording a fine shot. Did my friend shoot him? No, he did not. Why? He was frantically trying to extricate a jammed cartridge from the breech of his rifle. The deer joyously bade him good-bye, with a wave of their flags. After sitting down on a log and fussing with the gun for half an hour, my friend made a short cut for camp. On the way he had another good shot at a deer which he could not take, and on entering camp he would have smashed the Marlin rifle to pieces if I had not taken it from him.

I have nothing to say about the Peters' cartridges, for I never used any; but it strikes me as foolish for any firm to withdraw its patronage from a journal because of adverse comments on their goods by correspondents.

A thought suggested by the controversy is that since RECREATION, its editor and its patrons advocate the protection of game, they might favor, as the best means to that end, the use of Marlin rifles and Peters' ammunition. What could better promote the protection of game than hunting with rifles and ammunition that will not work?

You might even carry the idea farther by buying and presenting this combination to the game hogs as fast as you obtain their names and addresses.

W. H. Sanborn, St. Catherines, Ont.

# A YEAR'S SUPPLY OF CIGARS FREE

You may have noticed the above announcement before with disbelief. We have overcome the skepticism which assails any radical departure from established trade customs.

We offer you two years' smoking for the price of one: twice as many or twice as good cigars for the same money; or the same number for half the money; your favorite cigar or a better one for one-half what you pay over the counter—A STRAIGHT 50 PER CENT. SAVING FOR YOU, any way you figure it.

All made possible since we "BURNED OUR BRIDGES BEHIND US" by cutting loose from the wholesalers, who had taken our product for years, and going straight over the head of Jobber, Salesman, Retailer and all—direct to you, with the same established, time-tested brands; selling them to you by the box, at actual Jobber's Factory prices.

Our proposition rests upon our ability to please you and thousands like you, even to the extent of building cigars especially for you, if we cannot please you from our stock.

We have done this for many years with the jobber, salesman and retailer between us; why not all the more so now, dealing direct, especially when

## Saving You One-Half YOUR SMOKING EXPENSE?

No risk to you. Everything we say—proven to you and confirmed by you or

### YOUR MONEY BACK

No expense to confirm our statements or your judgment, is there any reason for not saving yourself half your smoking expense and having your taste pleased every time? Why give it to the long succession of "in between" men unless that is your pet charity?

In order to get the benefit of BUYING DIRECT as soon as possible, send for our booklet "Rolled Reveries," which explains everything, or to hasten matters—we will at first send you assortments from which to make selections. For \$1.00 an assortment of 25 cigars showing 15 ten cent and 10 five cent values; for 60 Cents 12 ten cent and two-for-a-quarter values; for 35 Cents, twelve high-grade fives; for \$1.25 25 assorted ten cent cigars. Each separately wrapped and described, showing you how two-for-a-quarter and ten cent cigars can be bought in boxes of 25 and 50 for from four to six cents each, others from two to three cents each. All Transportation Charges Prepaid.

Dayton, Ohio.

"If you will send about a dozen of your trial order blanks, I will try and get some more people. The cigars are fine."

Name supplied on request.

**JOHN B. ROGERS & CO.**

"The Pioneers"

92 Jarvis Street

Binghamton

N. Y.

**SQUIRES' SIBERIAN MOOSE HUNTING BOOTS & SHOES**

Made only by **HENRY C. SQUIRES & SON**  
20 Cortlandt St., New York

The **leather** is waterproof, fine grained, tough and pliable. The **linings** are russet calfskin. The **soles** are best waterproof anhydrous oak leather, **stitching** of silk, English back stays, bulldog toes, extra heavy **eyelets**, **Pratt fasteners** and **hand made throughout**. Price **\$7.50** net. Short Boots **\$8.50**, Knee Boots **\$10**, Cavalry Style Boots **\$12**.

Special circular giving detailed information free for the asking.



Mention RECREATION.

**Another Good Offer:** To the first person sending me five subscriptions to RECREATION and five dollars, before April 1st, I will give a 2 by 3½ printing press, and type to go with it. To any person sending me two subscriptions and two dollars I will give a silver-plated napkin ring. To any person sending one subscription, I will give a sterling silver ring. All persons sending me one subscription, please send finger measurement. **A. J. Brodhead,**  
42 Sayre St., Elizabeth, N. J.

**A Hunting Knife Free.** To any person sending me three yearly subscriptions to RECREATION and \$3, I will send a pocket hunting knife with handle 5½ inches long and blade 5 inches long. Fine steel, excellent workmanship. Your name and address and your L.A.S. number if desired inserted on a plate in the handle.  
**Geo. W. Mains, McKeesport, Pa.**

**Do You Want a Drinking Cup Free -** Send me \$1 for a new subscription to RECREATION and I will send you a fine nickel-plated folding drinking cup. For 10 cents extra will send by registered mail. **Mrs. Thomas H. Walker, 295 Merrimac Street, Manchester, N. H.**

**Mexican Opals Free:** To any one subscribing to RECREATION through me, I will send a beautiful genuine Mexican Opal, large as a cean.  
**A. Thompson, Box 332, San Antonio, Tex.**

**For Sale:** Bardon Rifle Range Telescope, power 33, in first class condition. Price \$12. **F. F. Brush, Washington Boro., Pa.**

**For Sale or Exchange:** Practically new Trunk Shape Gun Case. Cost \$27, very fine. **Roy L. Schroder, Van Horne, Iowa.**

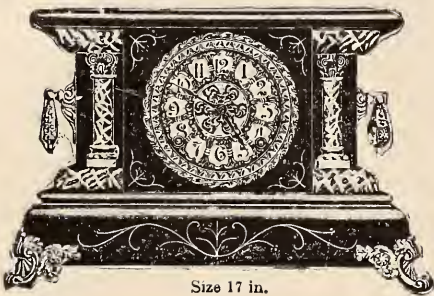

Size 17 in.

A skilled mechanic has invented lately a **Musical Clock** which, besides keeping perfect time, running 8 days with one winding, striking the hours and halves, will also **play favorite airs every half hour**. As the cost is very low, many prefer buying the clock with the musical attachment. Ask your jeweler for it or send to **E. L. CUENDET, Mfr., 7 Barclay Street, New York**

**RELICS OF A DISAPPEARING RACE**

**Buffalo Skulls**

**WITH POLISHED OR UNPOLISHED HORNS**

Also polished or unpolished horns in pairs or single. Polished horns tipped with incandescent electric lights; polished hunting horns; mirrors hung in polished horns, etc. These are decided novelties and are in great demand for sportsmen's dens, offices, club-rooms, halls, etc. Send for illustrated catalog. Mention RECREATION.

**E. W. STILES**

**141 Washington St. Hartford, Conn.**

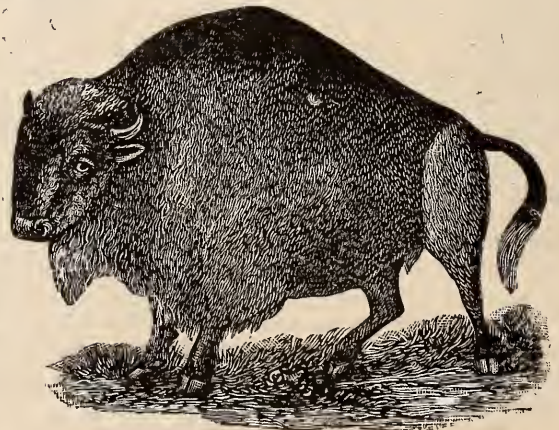

We have not much to protect in Massachusetts except our game birds and fishes, but we bid fair to have. The increase in the number of deer in this section is remarkable. They are seen in all the surrounding country repeatedly, in bunches of 2 to 5; and our well nigh assured re-enactment of the 5 years' close season law extends for another period the inestimable benefit of their protection. Our legislative hearing on the bill to prohibit for an indefinite period the sale of grouse and woodcock developed no opposition whatever, and we look to its passage by house and senate as almost a certainty.

Too much credit can not be given Hon. Herman S. Fay, of Marlboro, chief warden of the L. A. S. of Massachusetts, who has had charge of the bill. His energetic, careful and tactful direction of the interests in his charge has been an immense aid in the important work accomplished; and the sportsmen of this State should be greatly indebted to him and his co-workers.

The L. A. S. is the only national organization of sportsmen that has lived and accomplished things in the field of game and fish protection.

More power to your elbow!

Ernest Russell, Worcester, Mass.

**Free:** To any person sending me \$1 for a year's subscription to RECREATION I will give free a Fountain Pen with filler or a Webster's Dictionary, indexed. C. C. Talbot, 30 Union Street, Putnam, Conn.

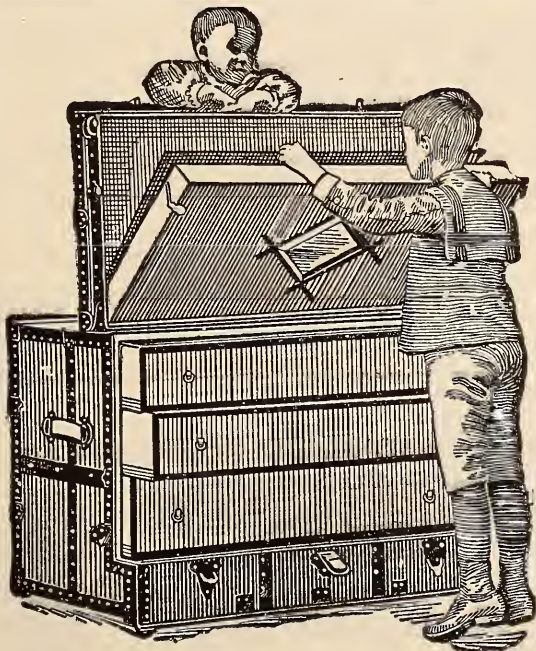

**Stallman's Dresser Trunk** Have you seen one? It is up-to-date. Think of it, everything within reach. No heavy trays, but light, smooth drawers. Holds as much and costs no more than a good box trunk. Hand riveted, almost indestructible. Once tried, always recommended. Sent C. O. D., privilege examination. ec. stamp for catalogue. Mention RECREATION.

**F. A. STALLMAN,**

87 W. Spring St.,

Columbus, O.



## SIGHT RESTORED

Quickly and at little expense in patients' own home.

The testimony of many people who have been so wonderfully benefited by the Oreal Dissolvent Method is ample evidence of the merit which it possesses. It has not been in some isolated instances where a permanent cure has been effected, but in every case where the treatment was given a fair trial. With all of its marvelous power it is absolutely harmless, and it is for this reason that Dr. Oreal permits the majority of his patients to treat themselves in their own homes, which is not only convenient, but much less expensive than if they were obliged to come to him. Thousands are being cured in this way every year. Mrs. Aurelia P. Rifle, 78 Niagara St., Buffalo, N. Y., cataracts; Mrs. C. H. Sweetland, Hamburg, Iowa, paresis of optic nerve; both cured themselves at home, restoring their sight completely in a few months' time, by applying this treatment under Dr. Oreal's direction.

Dr. Oreal has just issued the twenty-third edition of his book, "Eye Diseases Cured without Surgery," which tells how you can cure yourself at home. It accurately describes and illustrates all forms of eye diseases, and will be of valuable assistance to those who are afflicted. It is sent free to anyone who writes for it. Cross-eyes straightened by a New Method—always successful. Address OREN ONEAL, M.D., Suite 839, 52 Dearborn St., Chicago.

## REVELL & CO.

CHICAGO



## FURNITURE OFFICE DESKS

THE LARGEST DISPLAY  
THE LOWEST PRICES

ALEXANDER H. REVELL & CO.  
Wabash Ave. and Adams St., CHICAGO, ILL.

# PAROID ROOFING

"It Lasts"

HIGHLY recommended by sportsmen for covering camps and other buildings where a good, economical roofing is desired. Easy to apply, with roofing kit inside each roll.

*Send for Samples*

Mention RECREATION.

**F. W. BIRD & SON**  
MAKERS  
CHICAGO NEW YORK  
EAST WALPOLE, MASS.

## The Buffalo Is Well Nigh Extinct

And every nature lover wants a relic of him. Here is a chance to get it:

I have in stock a limited number of buffalo horns, highly polished and fitted with nickel plated flanges at the base, so that they can be screwed on the wall, thus forming

## A Novel and Effective Gun Rack

So long as the supply lasts I will give a pair of these horns for

### 3 Yearly Subscriptions to RECREATION

Sample copies for use in canvassing furnished on request. Address

Recreation, 23 W. 24th St., New York



The "Victor" is the real talking machine; its sound is natural. Band playing, monologues, comic or religious songs, all are reproduced as clear as if the artist was present. When ordering, **get the latest styles**—we charge no more than others who offer you old styles. Get our full catalogue FREE.

E. L. Cuendet, 7 Barclay St., New York

The Reason the LUTHER HAND-MADE GLOVE will not rip



Machine sewing cuts itself



Hand sewing cannot.



## A Practical Hunting and Driving Glove

Made for practical, comfortable, durability. No Oil. No Odor. No Animal Glue. Practically seamless. Cannot Rip. Unaffected by moisture of any kind. If soiled, may be washed with soap and hot water, without injury. The Luther Fastener is adjustable, fits any wrist and cannot get out of order. Illustrated booklet, samples and self measurement rule on application.

If you prefer to buy through your dealer send us his name

No. 308 Driving Glove	postpaid anywhere	\$1.50,	made to measure	\$2
No. 320 Gauntlet,		2.50,		3

J. P. LUTHER GLOVE CO., 536 Pearl St., Berlin, Wis.

Small game is scarce here. A few squirrels, an occasional rabbit, and now and then a quail, constitute the whole list. Everybody hunts quails, and many are killed in close season.

Last Christmas a friend and I arranged for a turkey hunt at a point 15 miles from here, where my friend had been told a few might be found. We reached our destination at nightfall, went early to bed, and woke to find the ground covered with freshly fallen snow.

By daylight we were in the woods, where I soon struck the track of a big gobbler hot and fresh. My friend presently joined me, and for 3/4 of a mile we followed, trailing him at last to cover in a windfall. When he broke, my friend knocked a feather bed out of him with No. 6 shot, and I sent 3 invitations after him with my 38 Winchester, but we didn't get him.

Rabbits made up our bags, I 4, my friend 6.

Charles Goss, Paoli, Ind.

**The Best Offer Yet.**—To any person who will subscribe to RECREATION for one year through me I will send free a small water color landscape, hand painted, suitable for framing; or a hand painted silk bookmark. For two subscriptions I will send a fine Mexican opal scarf pin worth ordinarily from \$1 to \$1.50.

Don M. Harris, 308 Crawford Road, Cleveland, Ohio.

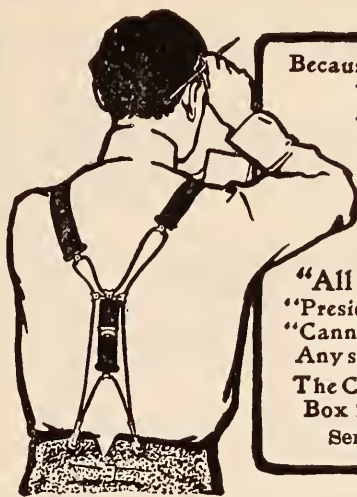

Because of their construction  
**President Suspenders**

give most  
**Comfort & Service**  
Guaranteed

"All breaks made good"  
"President" on buckle means  
"Cannot rust" 50c. and \$1.00  
Any shop or by mail prepaid  
The C. A. Edgerton Mfg. Co.  
Box 219-N Shirley Mass  
Send 6c. for Catalogue

**Journalism: Story-Writing**



taught by mail. MSS. sold on commission; criticised, revised and prepared for publication. Send for free booklet. "Writing for Profit;" tells how to succeed as a writer. Thornton West, Editor-in-Chief; founded 1895.



**THE NATIONAL PRESS ASSOCIATION,**  
The Baldwin, No. 109 - - - Indianapolis, Ind.

**A DOLLAR RATE BOOK FREE** *To Advertisers*

We will send postpaid, entirely without charge, to any business house that is interested in the subject of advertising, a copy of a bound volume we have recently issued entitled "Current Rates of Live Publications," giving list of leading towns throughout U. S., populations, principal papers, circulations and publishers' rates for advertising space on small and large contracts. Regular price of this volume is \$1—We will send free upon receipt of ten cents in stamps to cover postage.

**FULFORD, PAINTER & TOBEY, Inc.,** Advertising Agents  
N. W. Cor. Wabash Ave. and Randolph St. CHICAGO, ILL.

**The Celebrated**  
**THOMPSON-QUIMBY**  
Hunting Boots, Shoes and Moccasins

**THOMPSON**

I have on file measurements of all who bought Boots and Shoes of the W. Fred Quimby Co., of New York for the past 20 years, and I make the same grade of sportsmen's footwear as they made. I was superintendent of the shoe department of that firm and bought the right to make these boots and shoes. Get a pair now. They will last years and are the cheapest in the end. I refer by permission to the Editor of RECREATION.

Measurement blanks and prices on application. Mention RECREATION.

**T. H. CUTHRIE**  
33 William Street, NEWARK, N. J.

**THOMPSON**

All Work Guaranteed

**WEBBER'S**  
**JERSEY COAT**

Costs no more than old-fashioned blouse to pull over the head. Designed for trap shooting in hot weather, but suitable for any purpose. Good thing for fishing, chicken shooting or office coat. Very light weight but strong and made to fit. Ask your dealer for it. If he does not have them, send me your size and price, \$2, and I will send you one to fit, charges prepaid.

**GEORGE F. WEBBER, MFR.**  
Station A, Detroit, Mich.

# Spratts Patent Dog Soap

## THEY FIGHT FOR SPRATTS



Is of the greatest value to dog owners, as it is entirely **FREE FROM POISON**, and at the same time most effective in the destruction of lice and fleas. Moreover, it keeps the skin free from scurf, prevents Mange and other skin diseases. No other soap should ever be used in preparing dogs for exhibition; it leaves the coat smooth and glossy.

Spratts Patent Dog Soap contains no carbolic acid or coal tar, but is nicely perfumed and produces a fine lather. Recommended by kennel owners throughout the world. Once tried, always used.

**Price 20 cents per Tablet, by mail**  
None but the best can be the cheapest.

### Spratts Patent Antiseptic Soap

is instant death to all parasites, lice, ticks, the mange parasite, bacteria, etc. **Price per Tablet, 50c.**

Write for our Catalogue, "Dog Culture," with practical chapters on the feeding, kenneling and management of dogs, post free.

We also manufacture a specially prepared food for dogs, puppies, rabbits, cats, poultry, game, pigeons, fish, birds, etc.

### Spratts Patent (America) Limited

450 Market St., Newark, N. J. 714 S. 4th St., St. Louis, Mo.  
1324 Valencia St., San Francisco, Cal.

## Squab Book Free



Squabs are raised in 1 month, bring *big prices*. Eager market. Astonishing profits. Easy for women and invalids. Use your spare time profitably. Small space and capital. Here is something *worth looking into*. Facts given in our **FREE BOOK**, "How to make money with Squabs." **PLYMOUTH ROCK**

**SQUAB CO., 11 Friend St., Boston, Mass.**

## Money in Squabs and Pheasants

I sell **BETTER** breeders for less money than any other dealer in America, and you are *sure* to get **ONE MALE** and **ONE FEMALE** for a **PAIR**, not just **TWO BIRDS**. I will buy **all** you raise and pay you more than any one else. Send stamp for my catalogue which tells you all, plan, prices, etc. I have stock and eggs for sale at **all times**—**PHEASANTS, POULTRY, PIGEONS, ANGORA CATS, SWANS, ALL kinds of RARE AND FANCY DUCKS, GEESE, PEAFOWLS, Etc.** I want to buy all kinds of **WILD DUCKS AND GEESE, YOUNG WILD ANIMALS.**

*No one has better stock than I or as cheap*

**GENEI DeGUARDINER, Natick, Mass.**

**Valley Farm Kennels, Simsbury (Hartford Co.) Conn.**

## Russian Wolfhounds

**The Most Magnificent Dogs That Live**

Fups and full grown dogs from our champions for sale. Also Bull, Boston, Irish and Black-and-Tan Terriers, Cocker Spaniels, Bulldogs and American Foxhounds. Thoroughbred Poultry. New establishments stocked. Experienced attendants recommended, etc. Catalogues.

## Cavies or Guinea Pigs

Peruvian, Abyssinian or English Long or Short Haired. All colors. 40¢ to select from.

**T. RACKHAM,**

East Orange, New Jersey.



## Taxidermists' Glass Eyes for Stuffed Birds and Animals

### Oologists' and Entomologists' Materials

Send 5c. in stamps for catalogue  
**FRED. KAEMPFER, 88 STATE ST., Chicago, Ill.**

**Taxidermy work done in all its branches**  
Mention RECREATION

**For Sale.** The largest collection of Game Heads, Horns, and Antlers in America. A total of **TWO HUNDRED AND FIFTY SPECIMENS**, including many record heads and exceptional freaks and rarities. Full information and catalogue on application.

**A. E. COLBURN,**

Bond Building, Washington, D. C.

## FLORIDA BIRDS.

I have on hand a fair assortment of our Native Bird Skins, suitable for schools, museums or private collections.

During the season of 1903 I will collect any birds or mammals to order.

Finest mounted work a specialty.

**R. D. HOYT, Taxidermist,**  
SEVEN OAKS, FLA.

**Do you enjoy big game hunting?**

**Or Trout Fishing?**

**Or Mountain Climbing?**

**If so, write us and we can accommodate you.**

We keep 65 head of horses. We employ a full corps of experienced guides, packers, and cooks.

We have a complete outfit of riding saddles, pack saddles, tents, stoves, cooking utensils, tableware, and everything necessary for touring and camping in the Mountains.

We live at Banff. The Eastern gateway of the Canadian Rockies.

And can send you anywhere you may wish to go from this point

*North, East, South or West.*

**Address: BREWSTER BROS.**  
**Banff, Alberta, Canada.**



## INDIAN CURIOS

WHOLESALE & RETAIL  
CURIO DEALERS'  
SUPPLY DEPOT.

Bead Work, Baskets, Elk Teeth, Mexican Goods, Fossils, Minerals, Arrow-Heads, Pottery, Alaska Ivories, Shells, Agates, Photos, Great stock, Big Cata. 5c., stamps. Mention RECREATION. If a dealer, say so.

**L. W. STILWELL**

DEADWOOD

SO. DAKOTA



**FREE.** To anyone subscribing to RECREATION through me I will give a cloth copy of one of Cooper's, Dickens', Dumas', Thackeray's or Conan Doyle's books. Address,

**J. M. RUGEN, 2108 West Lake St., Chicago, Ill.**

**FINE MOUNTED GAME HEADS, BIRDS, ETC.,** for sale at unheard-of prices.

Send 10 cents for photos.

**JOHN CLAYTON, Taxidermist, Lincoln, Maine**

**For Sale or Exchange:** Gun Cabinet, 80x37x16½ inches, made of beautiful bird's-eye maple and quartered oak; cost \$60. Will sell for \$35 or exchange for canvas boat or other desirable sporting goods.

**T. N. Billings, New Haven Mills, Vt.**



# Ostermoor Patent Elastic Felt Mattress \$ 15.



"Yes, if you will include Ostermoor Mattresses in the Furnishings." Edwina Howard age 11

(Even the children are waking up. A bright little girl, Edwina Howard of Rockyford, Col., appreciates the way a "proposal" should be accepted to-day. Her entire drawing is reproduced.)

Every sale of an OSTERMOOR means that we have convinced somebody that Ostermoor Patent Elastic Felt is an improvement on the old-fashioned hair mattress and at a less price. It is the mark of progress—the breaking down of old ideas. If you still think a hair mattress is *good*, you may find out by our free trial offer (see below) than an OSTERMOOR is *better*.

If you have learned by sad experience that even the most costly hair mattress will sag and lump—that it takes many dollars or much dirty work (or both) to keep it clean and comfortable, you will rejoice in an OSTERMOOR that will wear and remain the acme of comfort for 20 to 30 years without renovation, with only an occasional sun-bath to keep it in perfect condition. It is vermin proof—moth proof.



## If you have read thus far, how can you keep from buying?

Perhaps you don't believe us! That would not be surprising—many firms make exaggerated or, at least, over-enthusiastic claims. We want to be as conservative as we are fair. It costs you nothing to prove the truth of our claims in either one of two ways:

### THIRTY NIGHTS' FREE TRIAL.

2 feet 6 inches wide, 25 lbs.	\$8.35
3 feet wide, 30 lbs.	10.00
3 feet 6 inches wide, 35 lbs.	11.70
4 feet wide, 40 lbs.	13.35
4 feet 6 inches wide, 45 lbs.	15.00

All 6 feet 3 inches long.  
Express Charges Prepaid.  
In two parts, 50 cents extra.  
Special sizes at special prices.

You can have an Ostermoor Mattress, sleep on it thirty nights, and if it is not better than any other mattress you have ever used—if it is not all you even HOPED for, return it at our expense and your money will be immediately refunded without question. What more can we do to convince you?

### SEND FOR OUR FREE BOOK

of 96 handsomely illustrated pages, entitled "The Test of Time." A POSTAL WILL DO. Read the letters from men and women of national reputation. We can't BUY TESTIMONIALS from such men as Rev. Dr. Robt. S. MacArthur, C. Oliver Iselin, or such others as appear. The book also describes pillows, window-seat cushions, boat cushions, church cushions.

EVERY GENUINE

**Ostermoor**  
Mattress

BEARS THE NAME

**Ostermoor**

AND TRADE-MARK LABEL

**OSTERMOOR & CO. 114 Elizabeth Street, New York.**

Canadian Agency: The Alaska Feather and Down Co., Ltd., Montreal.

# Fisk's Aerating Minnow Pail



The only Minnow Pail in which Minnows can be kept alive indefinitely.

Has an air chamber at the bottom holding 26 cubic inches of condensed air forced in by the Air Pump attached, and by a simple rubber attachment the air is allowed to escape into the water gradually supplying the fish with the oxygen consumed by them. One pumping is sufficient for ten hours.

Height, 1 foot; diameter, 10 inches; weight, 7½ lbs.; water, 2½ gallons; keeps 50 to 150 minnows, according to their size.

**IT KEEPS THEM ALIVE**

Send for circular Mention RECREATION

**J. M. KENYON & CO.**  
214 Twelfth St., Toledo, Ohio, U. S. A.

**For Sale:** Winchester Repeating Shot Gun, 30 inch, full choke, fine Damascus barrel, 12 gauge, in fine shape throughout. Cost \$27; will sell for \$20; also 38-40 Winchester, model 92, fitted with Lyman sights; in good shape. F. L. Atwell, Durham, Conn.

**Wanted:** Good Second Hand 20 foot Gasoline Launch; delivery any time before Nov. 1st. Geo. Scott, 184 South St., New York City, N. Y.

**For Sale or Exchange:** Spaniel Pups 3 months old.  
E. A. Cooley, Rodman, N. Y.



## Points on Angling

More complete than ever before

### The Habits and Haunts of

# GAME FISH

and How to Catch Them

*Mailed free on application*

**THE SPECIALTY MFG. COMPANY**  
Box 62a, Goshen, Indiana

## Looking for Fishing Tackle?



If so, write us for catalogue and price list. We publish the most complete book of this kind ever put out. We list and illustrate in it about everything that an angler ever needs on a fishing trip.

And we sell the goods as low as high quality goods can possibly be sold.

Every angler in the United States should have a copy of this book for ready reference.

Write for it. We will do the rest.

## WM. MILLS & SON

21 Park Place, New York

### ATTENTION BASS FISHERMEN !!

**What It Is.** A Bass lure combining all the good points of the old fashioned spinner baits with the construction of the modern wooden minnow.

**What It Will Do.** This lure is constructed in a new manner with a new feature and will catch more bass than any other artificial lure.

**How To Get It.** Send one dollar to Recreation for a year's subscription to be credited to my account and I will mail you one postpaid. **W. B. HAYNES, 274 Park Street, Akron, Ohio.**

### GUNNERS AND ANGLERS



Here is what you need. A powerful, compact **Electric Flashlight** to carry in the pocket. The hardest storm cannot blow out this light, nor can your fingers become too cold to operate it. A brilliant light instantly, without noise or delay, just press the button.

Safe in the stable or hay loft where lamp or candle would be dangerous.

Price, **\$2.00.** Good for **5,000 flashes;** then a new battery for 30 cents. *Send for Catalogue.*

**American Electrical Novelty and Mfg. Co.**  
Dept. A—Hudson & Spring Sts., NEW YORK  
Dept. H—Masonic Temple, CHICAGO



Camp Bristol

One enthusiastic sportsman—a constant user and admirer of the

**“BRISTOL” STEEL RODS**

has his occasional *habitat* in the camp above pictured. He writes:—

“I have discarded my split bamboo and my wood rods I formerly ‘swore by,’ and am ‘in love with’ the ‘BRISTOLS’ you sent me. Tell the boys to throw away all nonsensical prejudice, and hasten to form the acquaintance of a ‘Bristol’ Rod—for there’s millions (of fish) in it.”

We will send you our free catalogue if you like—then you can do as you choose.

**The Horton Manufacturing Company**  
No. 73 Horton Street, Bristol, Conn.



## WITH A "Y AND E" AUTOMATIC REEL

you simply press a lever with your little finger, instead of winding a crank like fury. The reel takes in every bit of slack, no matter how quickly your fish may turn. The result is

### YOU LAND YOUR FISH

where, with an ordinary crank reel, you'd never get him in the world! These are the only reels which give you a chance to play your fish—to get all the sport there is in it. No reels are more finely constructed. There's no "lost motion;" they will stand all sorts of "rough and ready" use.

It's "all off" with any other reel when a "Y and E" gets into the game.

### 1903 MONEY PRIZES

There are 5 of them—3 of \$25.00 each for anybody over 16, and 2 of \$15 each for Boys (and Girls) not over 16.

**Write to-day** for free contest blank and handsome new catalogue "**299 R.**"

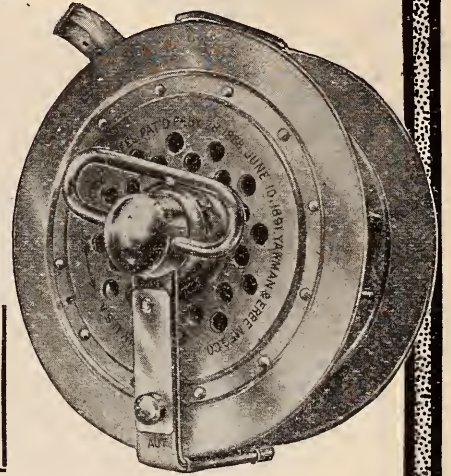

Little finger does it.

### "Y AND E" Automatic Style 1

A man's reel, but mighty fine for a boy! Carries and automatically rewinds 90 feet. Weight 8 oz. Diameter 3 1-32 inches.

Price \$5.00

### Automatic Combination, Style B

Price \$8.00

The only perfect reel for fly-and bait-casting. Either free or automatic instantly, by the slipping of a catch. Diameter, 3 3/8 in. Weight, 11 oz. Carries 300 feet. Winds 90 feet automatically, without rewinding. Buy from your hardware or sporting goods dealer. If he can't supply you, we'll mail to you prepaid on receipt of price anywhere in the U. S. or Canada. 4 other styles.

### YAWMAN @ ERBE MFG. CO.

Main Factories and Ex. Offices **Rochester, N. Y.**

## AN IMPORTANT OFFER

For 2 Yearly Subscriptions to RECREATION

I will send you

### A RIFLE WICK PLUG

Made by HEMM & WOODWARD, Sidney, Ohio, 30 caliber up to 50 caliber.

OR

### A SHOT GUN WICK PLUG

20 gauge up to 10 gauge

For 3 Yearly Subscriptions to RECREATION

### A Pair of Shot Gun Wick Plugs

20 to 10 gauge.

Sample copies for use in canvassing furnished on application.

Address RECREATION, 23W. 24th St., N. Y. City

**Free:** For 1 year's subscription of RECREATION, through me, will give 1 Bromide enlargement, any size up to 11 x 14 inches, inclusive, from any negative not larger than 4 x 5; or from photographs. Negatives and Photos are to be returned to the owner. Here is a rare chance to get a large Photo from your pet Negative, also RECREATION for \$1. A. F. Evarts, Meriden, Conn.

### White Mountain Views Free

To any person sending me a subscription to RECREATION accompanied by \$1. I will send two mounted photos, on velox paper taken among the White Mountains, size 6x8; one shows Mt. Washington snow capped. To any one sending 2 subscriptions with \$2 I will send a souvenir of the White Mountains, size 4 1/2 x 5 1/2 containing seven photos. Send-P. O. Money Order.

**M. E. TUTTLE, Box 337 Dover, N. H.**



THE above cut shows our **INDEPENDENT EVEN SPOOLING DEVICE** that level winds your line on the spool of the reel, and also shows our **SPRING LOCK HOOK SHIELD** that muzzles and locks to the pole that dang'ing hook when not in use. We also make the Lightning Fish Scaler. Our prices are quoted in April, May and June numbers of RECREATION.

Descriptive Catalog free on request. Mention RECREATION.

**A. W. BISHOP & SON,**

**Racine, Wis.**

Agents for the New

# Liberty Reel

**Just Out.** Best Model and most improved Fishing Reel yet produced.

**SPECIAL FEATURES:**

- The drag is applied by the Handle.
- Tension of Click adjusted at will, or Free Running, if preferred
- Easily and quickly taken apart,
- German Silver and Hard Rubber,
- 100 yard Quadruple.
- Surely see this High-Grade Reel.

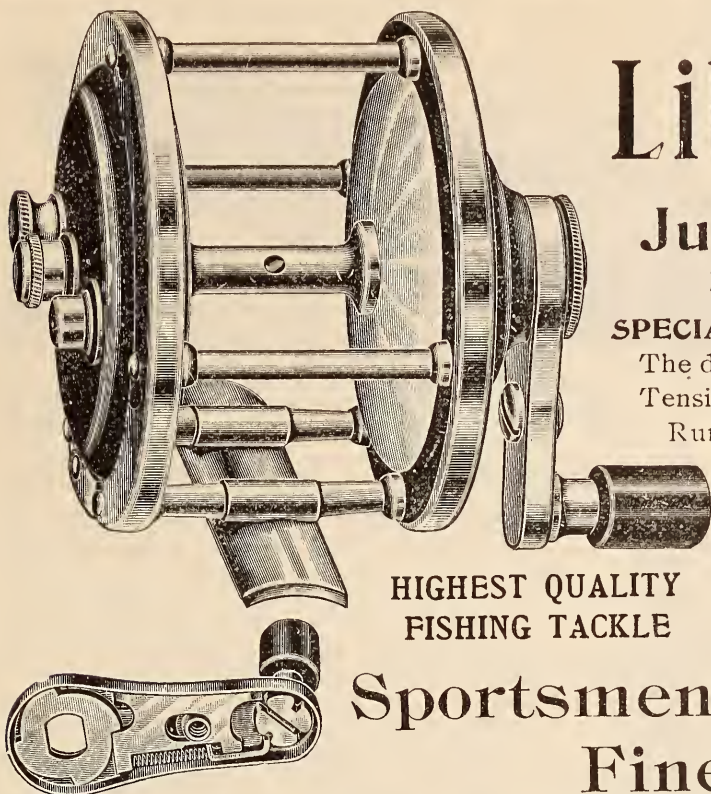

HIGHEST QUALITY FISHING TACKLE

PRICE, \$7.50..

## Sportsmen's Outfits and Fine Guns

Send 6 Cents for full Illustrated Catalogue.

# WM. READ & SONS

107 Washington Street, BOSTON

Established 1826

### Small Profits—Quick Sales

## TROUT FLIES

for trial—send us



- 15c** for an assorted sample doz. Regular price, 24 cents. **Quality A Flies**
- 30c** for an assorted sample doz. Regular price, 60 cents. **Quality B Flies**
- 60c** for an assorted sample doz. Regular price, 84 cents. **Quality C Flies**
- 60c** for an assorted dozen Regular price 84 cents. **Bass Flies**

### SPLIT BAMBOO RODS

Fly Rods **57 cents** Bait Rods  
10 feet, 6 ounces 9 feet, 8 ounces

With cork grip and extra tip, in wood form

Try our new Braided Silk Enameled Waterproof

### METAL CENTER LINE

Size No. 5, 4½ cents per yard. Size No. 4, 5½ cents per yard  
Put up in 10-yard lengths connected.

**THE H. H. KIFFE CO.**  
**523 Broadway, New York City**

Catalogs of any of above goods free on application.  
Mention RECREATION.

## IT NEVER FAILS

The S. & W. Artificial Bait

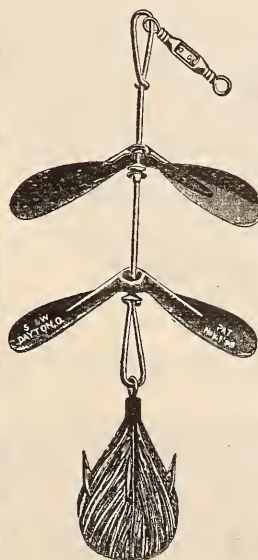

Is the most successful bait made. When in motion it resembles a minnow so closely that it never fails to delude the fish. Its construction makes it almost impossible for a fish to strike and not get caught.

### A GREAT SELLER

Do you fish? Buy one. You will never be without one afterward. Why? It will catch fish. Can be used with rod or hand line.

Dealers send for illustrated booklet and get our prices.

If your dealer cannot supply you, send 50c. at once for one (post paid) to

## STARK & WECKESSER

57 S. Main St. :: : DAYTON, OHIO, U. S. A.

For Fishing  
Duck Shooting  
Cruising  
Or Exercising



GET A  
**BURTON**  
Sectional Boat

For convenience it is away ahead of any one-piece boat in transporting.

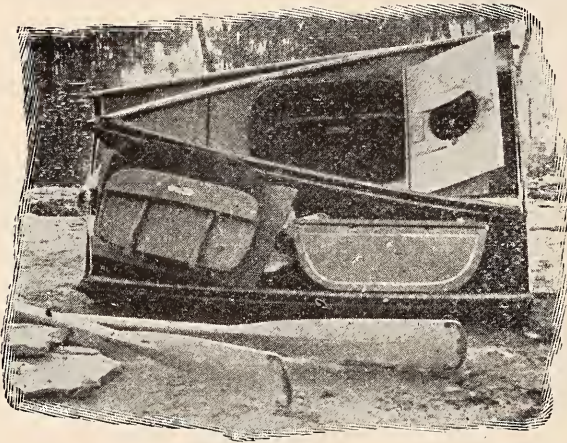

You set one section into the other, lash them together, and ship by rail or wagon, anywhere you wish to go.

Or you can carry them from lake to lake, or from river to river, easily and comfortably.

Made of Galvanized Steel, Non-rusting.  
No Wood Used in Construction.  
Light, Safe, Durable, Non-Sinkable.

Write for Illustrated Catalogue. Address  
**The Old Hickory Chair Co.**  
MARTINSVILLE, IND.  
Mention RECREATION.



# PATENTS

Quickly secured. **OUR FEE DUE WHEN PATENT OBTAINED.** Send model, sketch or photo. with description for free report as to patentability. **48-PAGE HAND-BOOK FREE.** Contains references and full information. **WRITE FOR COPY OF OUR SPECIAL OFFER.** It is the most liberal proposition ever made by a patent attorney, and **EVERY INVENTOR SHOULD READ IT** before applying for patent. Address:

**H. B. WILLSON & CO.**  
PATENT LAWYERS,  
Le Droit Bldg., WASHINGTON, D. C.

**No Other Reel Will Give**

Satisfaction after you  
have seen the

**"TALBOT"**



A thing more perfect was never wrought  
in metal. In tournaments always a victor.  
Among fishermen's treasures, the chief.

Send for Booklet F:  
**W. H. TALBOT, Nevada, Mo**

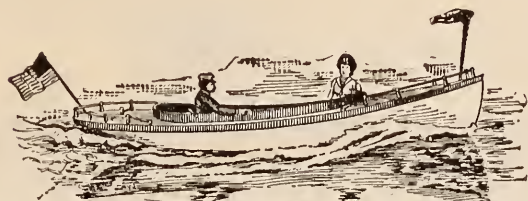

## BULLARD STEEL LAUNCHES, ROW AND PLEASURE BOATS, ARE EVERLASTING!

Safer than wood; have greater carrying capacity; always dry; no bolts or nails to rust.

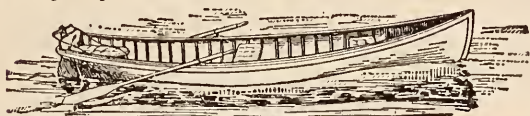

Boat Liveries equipped with the Bullard Steel Boats. Always have dry boats, that last a lifetime.

**STEEL BOATS CHEAPER THAN WOOD.**

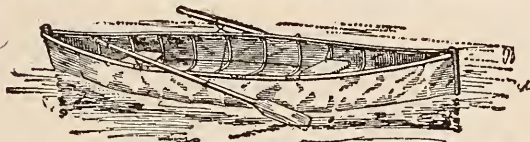

## THE OSGOOD FOLDING CANVAS BOATS

Original Canvas Boat; made for 30 years. Sold all over the world; used by U. S. Government; best Fishing and Hunting is where there are no boats, take one with you in trunk or bag. Non-puncturable. Folded or extended in one minute.

Send for catalogue illustrating all improved popular designs of Steel, Wood, and Canvas Boats, and Marine Engines.

**MICHIGAN CONSOLIDATED BOAT CO., LTD.**  
55 Main St., Battle Creek, Mich.

## THE HILDEBRANDT SPINNER



For Fly Fishermen. A spinner which spins, and also catches fish. Strictly hand-made and of the best material. No swivel required. Made with all kinds of Feather and

Buck-tail flies. For sale by dealers. Sent on receipt of 25c.

**J. J. HILDEBRANDT, Logansport, Ind.**

**For Sale:**—One Chesapeake Bay dog, 11 months old. Also young Chesapeake Bay puppies. They all are eligible to register.

Maurice Schindler, Sisseton, S. D.

# FAY & BOWEN

## Motors & Launches

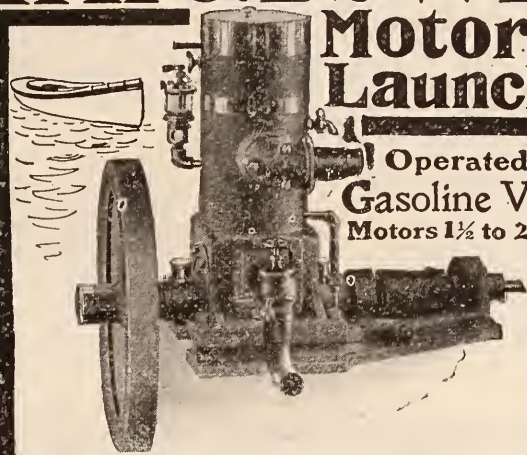

Operated by  
Gasoline Vapor  
Motors 1½ to 25 H.P.

**T**HE Fay & Bowen Marine Motor is a revelation to those who have used others. Reliable, safe, durable and easy to operate. Remarkable speed control. Best of all, it starts when you start it. No handle or crank is used. Our patent igniter is absolutely unique and always instant and positive in action. It is real y the only perfect and satisfactory igniter.

Motors complete from 1½ to 25 H. P. ready for installation. We also build handsome launches with motors installed and ready to run

Send for Catalogue.

**Fay & Bowen,**

28 Mill Street,

Auburn, N. Y.

## SEARCHLIGHTS

"The Clear View"

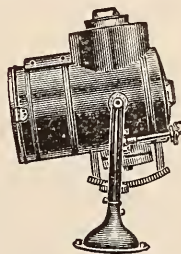

For Steamboats, Yachts, Launches, Sailboats, Automobiles, etc. A reliable light at small cost. Write for Catalogue.

**American Acetylene Stove Co.**  
536 Hennepin Ave.  
MINNEAPOLIS, MINN.

**For Exchange:** Moose head, in good condition, for a Goerz field glass or some make of equal value, or a good hammerless gun. J. W. B., care of RECREATION.

# PALMER

## Gasoline Engines and Launches

### LAUNCHES IN STOCK

17 ft. 1½-H. P. Engine \$195      20 ft. 3-H. P. Engine \$300  
25 ft. 5-H. P. Engine \$500

These boats are built of the best cedar and oak obtainable, and are copper fastened throughout.

Manufactured by

**PALMER BROS. = Cos Cob, Conn.**

NEW YORK OFFICE, 136 Liberty Street

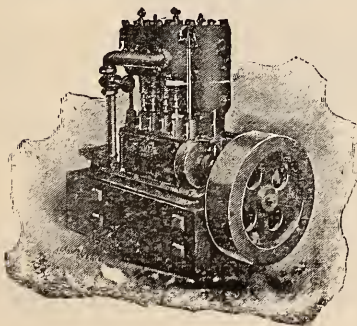

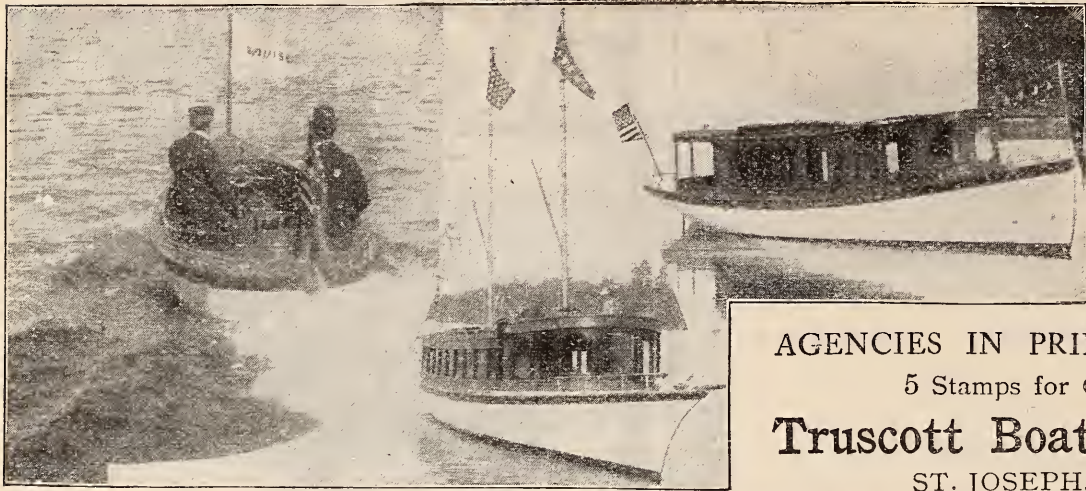

Handsome  
Boats  
Perfect running  
Motors

AGENCIES IN PRINCIPAL CITIES  
5 Stamps for Catalogue  
**Truscott Boat Mfg. Co.**  
ST. JOSEPH, MICH.

**D.M. TUTTLE CO.** 10 PINE STREET CANASTOTA, N.Y. **CATALOGUE FREE.**  
**BREAK SPARK. GASOLINE ENGINES & LAUNCHES. JUMP SPARK.**



**ACME FOLDING BOAT CO., MIAMISBURG, O.**

Send for catalogue of our full line of Folding Canvas Boats and Canoes, which have been adopted by Governments of United States, Canada and England. Just filled an order for U. S. Government who prefer our boats. Received medal and award at Chicago World's Fair! If you investigate we will get your order. **MENTION RECREATION.**

**Acme Folding Boat Company, Miamisburg, O.**

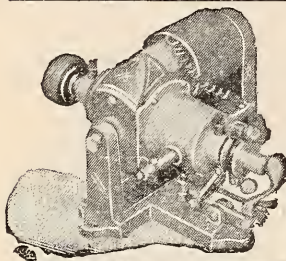

**To Owners of Gasoline Engines, Automobiles, Launches, Etc.**  
**The AUTO-SPARKER**  
does away entirely with all starting and running batteries their annoyance and expense. No belt—no switch—no batteries. Can be attached to any engine now using batteries Fully guaranteed; write for descriptive catalog.  
**Motsinger Device Mfg. Co.**  
76 Main St., Pendleton, Ind

Messrs. Schoverling, Daly & Gales, New York, write us that a customer of theirs wishes to sell a prosperous, well established sporting goods business in one of the most enterprising cities of Pennsylvania, with a population of 38,000 in the city and 75,000 in the county. Cash receipts \$11,000 to \$17,000 per annum. Stock well selected and in first class order; cost \$11,500. The business and good will will be closed out for immediate cash at 5 per cent. discount on the invoiced value of the stock, and nothing added for the good will. The reason for selling is that the owner has accepted a lucrative position, which requires all his time and attention.

**MARINE GAS ENGINES**

Experts for years have ranked our engines with the highest grade, and it is now being copied by other builders. We always endeavor to be on top and for 1903 offer an engine built from brand new patterns, with **NEW** and **ORIGINAL** features—just what other engines will have five years hence. If you want to be in the lead send for catalog fully describing all parts, and then buy a "Rochester".  
**ROCHESTER GAS ENGINE CO.**  
700 Driving Park Ave. Rochester, N. Y., U. S. A.

**Mullin's Galvanized Steel Boats**

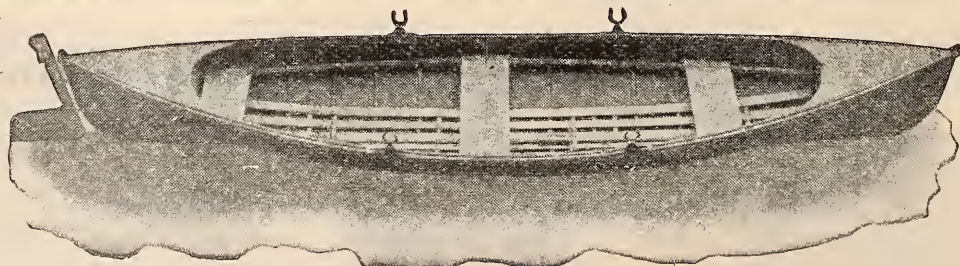

**THE QUEEN, 15 FEET, MODEL. PRICE, \$29.00**

The most durable and best boat on the market. Fitted with air chambers, makes it safe. No repairs. Always ready. Will last a lifetime. Send for copy of our handsome illustrated catalogue with full description and prices.

**W. H. MULLINS, 228 Depot Street, Salem, Ohio.**



# A Rushton Canoe

combines all the excellences that selected material, skillful craftsmanship and honest making can compass.

The Indian Girl model, shown above, is graceful, swift and staunch; it is made of cedar, canvas-covered, 15, 16, 17 and 18 feet long, in two grades, costing from \$30.00 to \$43.00.

I make the largest variety of pleasure boats and canoes produced by any one establishment in America. This is my 30th year.

*Send for free catalogue of pleasure boats, all-cedar and canvas-covered canoes, oars, paddles, sails and fittings.*

**J. H. RUSHTON,**

**817 Water Street, CANTON, N. Y.**

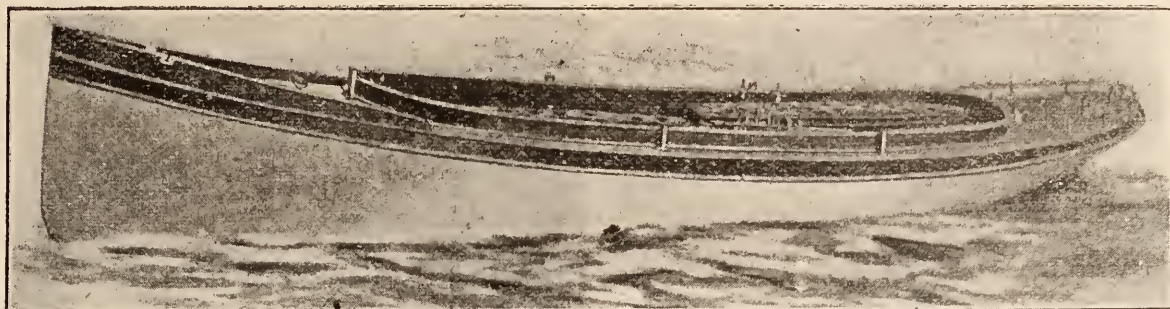

## LEAMAN BOAT COMPANY

WINNECONNE, WIS.

Manufacturers of Gasoline Launches, Sail, Row and Hunting Boats. Our prices are low, our work guaranteed. Launches, \$150 up. Row Boats, \$22 up. Hunting Skiffs, \$20 up. The oldest Boat Company in the State. Write for Wants. Mention RECREATION.

## To Amateur Photographers

Here is a Chance to Get a  
**FINE CAMERA EASILY**

A 4x5 Tourist Hawk-eye film camera listing at \$8, for 5 yearly subscriptions to RECREATION.  
A No. 3 folding Weno Hawk-eye film camera, listed at \$15, for 10 yearly subscriptions to RECREATION.

These are both neat, compact, well made and handsomely finished cameras, capable of doing high-class work.

*Sample copies for use in canvas-  
sing furnished on request.*

Address **RECREATION,**  
23 West 24th St. New York City.



**11-foot Special**

**Folding Canvas Boats** were not satisfactory until the **King** was produced. **It's a revelation** in boat construction. Nothing like it ever made. **Nonsinkable. Can't tip over. Puncture-proof.** Wear longer than a wooden boat. **No repairs.** No cost for storage. **Always ready.** Folds into a small neat package,—**carry by hand.** Used by the U. S. Navy. They are simply wonderful. A thoroughly patented article. Beware of imitation. Made only by ourselves.

A catalogue of 70 engravings and 350 testimonials sent on receipt of 6 cents.  
Mention RECREATION.

**King Folding Canvas Boat Co.**  
Kalamazoo, Mich., U. S. A.

# THE LATEST, SAFEST AND BEST CANVAS BOAT

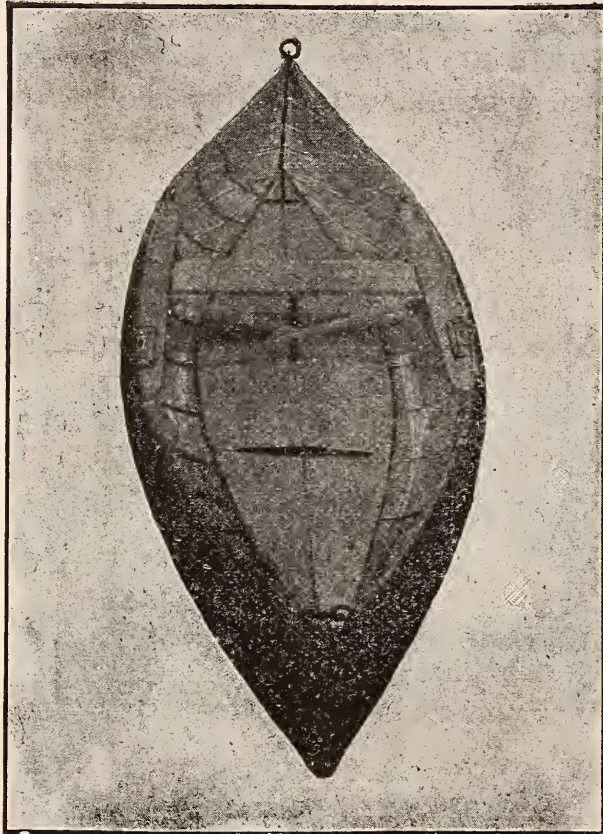

Is what we offer you. A Boat built on modern lines that will prove a pleasure to own and use. Selected materials used throughout, and it comes to you **guaranteed** the best. A handy and safe boat for fishing and shooting. Send 4 cents in stamps for catalogue and reliable testimonials.

Mention RECREATION.

**LIFE SAVING FOLDING CANVAS BOAT CO.**  
Kalamazoo, Mich.



Latest patent and improved Canvas Folding Boat on the Market. Puncture proof. Tempered steel frame. No bolts to remove. Folds most compact of any boat made.

SAILING. CAMPING. PROSPECTING. FISHING. HUNTING.

Established 1840

GEO. B. CARPENTER & CO.

MAKERS OF HIGH GRADE

TENTS, SAILS  
CAMP FURNITURE

Folding Cots  
Tables and Chairs

Oars, Paddles  
Marine Hardware

Copyright 1899  
Geo. B. Carpenter & Co.

The Largest and Most Complete Stock in the U. S.

Send 4c. in stamps for Tent and Camp Catalogue, or  
6c. in stamps for Marine Hardware Catalogue.

200, 202, 204, 206, 208 S. Water St  
CHICAGO, ILL.



## IN THE ADIRONDACKS—The New Hermitage At Lake Bonaparte, New York,

Once the property of King Joseph Bonaparte, and named in his honor.

The hotel has all the modern improvements and accessories. Broad verandas, wide roomy halls, large open fire-places, reading rooms, billiard rooms, telephone, daily mail.

Guests have the opportunity of enjoying delightful rowing, canoeing, bathing. The finest fishing in the Adirondacks, Croquet, Tennis.

A park containing 800 acres; beautiful walks and drives.

Handsomely illustrated book, giving full information, sent on request. Mention *Recreation*.

**DAVID SCANLIN, Proprietor, Bonaparte, New York.**

### MUSKOKA LAKE, ONT., CANADA Beaumaris Hotel

Finest situation on the Muskoka Lakes. Has been remodeled and enlarged. First class Nine-Hole Golf Links, Tennis Lawn, Bathing, Boating, Fishing. Best place in the country for hay fever people. Write for booklet.

**EDWARD PROWSE  
PROPRIETOR**

### ADIRONDACKS CAMP MOHAWK and COTTAGES

Fourth Lake, Fulton Chain.

Write for booklet Mrs. H. H. Longstaff, Old Forge, N. Y.

IN THE ADIRONDACKS

### Indian Lake House

Mountain View, N. Y.

C.C. Morgan, Prop.

ALL THE YEAR

All passenger trains on A. & St. L. R. R. will be met by boat and bus. Passengers conveyed directly to the house.

Rates. \$2 per Day.

Special Rates to Parties

See DEER HUNTING and TROUT FISHING to be found in the Adirondacks

## HOTEL AYERS

LAKE DUANE

Adirondacks Franklin County

DO YOU KNOW THE BEAUTIES  
OF THE GREAT NORTH WOODS?

*Here are some of the things you can find at Ayers:*

Deer, trout, and cedar boats.

Thousands of acres of primeval forests that the fires did not find this spring.

Seven beautiful lakes and several miles of shore line.

2000 feet elevation; magnificent mountain scenery.

Balsam-scented air; water from mountain springs.

Tennis, bowling, croquet and ping pong.

Splendid fishing, hunting, boating, and bathing.

EXCELLENT CUISINE and GOOD BEDS.

Wide verandas, open fires, post office and telegraph in house.

Miles of picturesque trails; an ideal forest home.

Write for booklet, itinerary; terms and references.

## W. J. AYERS & SON

Ayers, Franklin County, N. Y.

## Newhouse Traps

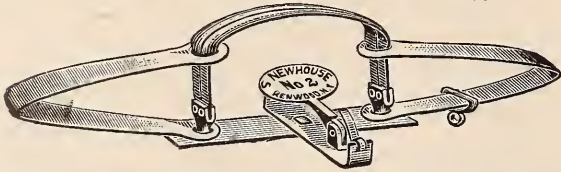

THE STANDARD FOR OVER FIFTY YEARS

Used by all professional hunters and trappers,  
who find that

**The Best Trap is the Cheapest**

Complete illustrated catalogue on  
application.

ONEIDA COMMUNITY, LTD., Kenwood, N. Y.

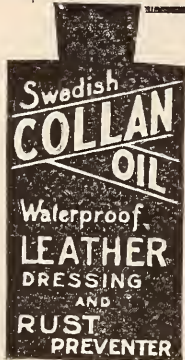

**"Collan-Oil"**

preserves leather and  
renders shoes and  
harness positively

**WATERPROOF**

Used by the U. S.  
the Army and Navy,  
and National Guard.

Send 25c. for trial can.

AGENTS WANTED

Write for terms and circulars

J. R. BUCKELEW

Dept. A.

111 Chambers St., N. Y.

## DuPont Smokeless

AT THE

PENNSYLVANIA STATE SHOOT

(Open and State Events Combined)

Mr. J. T. Atkinson, of New Castle, won

**HIGH AVERAGE**

Breaking 495 out of 525 Targets  
Shooting

## DuPont Smokeless

**KOENIG'S SHELL EXTRACTOR.**



10 Cts. Postpaid.

E. G. KOENIG, NEW JERSEY'S LARGEST GUN HOUSE

SOUTH BROAD ST., NEWARK, N. J.

Every shooter should  
have one—carry it in a  
vest pocket. Fits any  
gauge shell. Koenig's  
Gun Catalogue, Free.

## THE BRADLEY SHOT GUN SIGHT

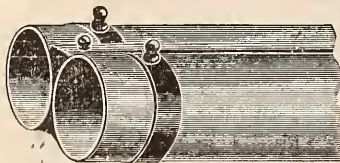

Wing Shooting is  
made easy and cer-  
tain by using this gun  
sight. Scores at trap  
and in field greatly  
increased by its use.  
Right and left birds  
are bagged as easily

as straight-away birds. Price 50 Cents, Postpaid.

C. L. BRADLEY, Inventor, Clarksville, Tenn.

## SOME GOOD GUIDES.

Following are names and addresses of guides who have been recommended to me, by men who have employed them; together with data as to the species of game and fish which these guides undertake to find for sportsmen.

If anyone who may employ one of these guides should find him incompetent or unsatisfactory, I will be grateful if he will report the fact to me.

### ALASKA.

Edwin Edelmann, Kenai, Cook's Inlet, moose, bear, caribou, mountain sheep, ducks, grouse and trout.

### FLORIDA.

Carson Bros., Frostproof, bear, deer, turkeys, quail, snipe.

C. H. Stokes, Mohawk, deer, alligators, turkey, quail, and snipe.

### IDAHO.

John Ching, Kilgore, elk, bear, deer, antelope, mountain sheep, trout and grouse.

Chas. Petty's, Kilgore, ditto.

### MAINE.

H. R. Horton, Flagstaff, deer, bear, moose, caribou, fox, grouse and trout.

W. C. Holt, Hanover, moose, caribou, deer, grouse and trout.

### MONTANA.

A. R. Hague, Fridley, elk, deer, mountain sheep, bear, grouse and trout.

Chas. Marble, Chestnut, ditto.

### NEW YORK.

Le Roy Still, Bayport, Long Island, ducks, quails, rabbits and grouse.

### WYOMING.

S. N. Leek, Jackson, elk, bear, deer, mountain sheep, antelope, grouse and trout.

James L. McLaughlin, Valley, elk, bear, deer, mountain sheep, antelope, grouse and trout.

### CANADA.

Wm. S. Andrews, Lillooet, B. C., deer, bear, mountain sheep, goats, grouse and trout.

B. Norrad, Boiestown, N. B., moose, caribou, grouse and trout.

Carl Bersing, Newcastle, N. B., moose, caribou, deer, bear and grouse.

## Big Game Hunters

FISHING AND OUTING PARTIES

Before planning trips other than in New Brunswick, should apply to

**The New Brunswick Guides Association**

Fredericton, New Brunswick, Canada,

for information. The Association comprises the leading and most reliable guides in the Province.

## Hunting Map of New Brunswick

Showing rivers, lakes, portage roads, carries, etc. Scale, 4½ miles to the inch, and folded to suit pocket. Mailed to any address on receipt of price, \$1.50. Checks accepted.

FRANK WHITEHEAD,

Fredericton, New Brunswick,

P.O. Box 303

Canada.

## George Stables

Dealer in Fancy Groceries, etc. Sportsmen's Provisions a specialty.

Only the best quality goods kept in stock. Prices on application. **Public Square, Newcastle on the Miramichi, NEW BRUNSWICK.**

**For Sale or Exchange**—A scholarship of complete course in electrical engineering at International Correspondence Schools, Scranton, Pa.

J. E. Jones, Atoka, Indian Territory.

## FORTY-EIGHT PAGES

are required just to describe a lot of interesting booklets of travel, any one of which can be obtained by sending a few cents in stamps. These forty-eight pages make the

### ILLUSTRATED CATALOGUE

OF THE

### NEW YORK CENTRAL'S

### "FOUR-TRACK SERIES"

Embracing 37 Books of Travel.

A copy of this catalogue will be sent free, post-paid to any address, on receipt of a two-cent stamp, by

**GEORGE H. DANIELS,**  
Gen'l Passenger Agent,  
Grand Central Station, New York.

### "Going Into the Woods" IS NOW THE POPULAR FAD

### **Maine** Is the Recognized Summer Playground of the Nation

There can be found all the pleasures of Fishing, Hunting, Canoeing, Mountain Climbing and Absolute Rest.

During the summer season there are Four Express Trains daily to Bar Harbor, Three Express Trains daily to the White Mountains. One through train New York to Bar Harbor

#### **Through Trains to All Hunting and Fishing Resorts.**

*Send for Guide, Books and Maps.*

F. E. BOOTHBY, General Passenger Agent.  
GEO. F. EVANS, Vice-Pres. and Gen. Mgr.,  
Portland, Me.

I would like to correspond with a few Sportsmen and Sportswomen relative to unexplored regions. Beautiful undisturbed Nature, pure air, pure water, big game, big fish, trout and muskalonge. One day's paddle from railroad.

**E. C. TRIPP,**  
Atikokan, Ontario, Canada, Seine River Dist.

### **BEST FISHING**

AND

### **FINE HUNTING**

Earliest and latest Moosehead lake fishing is had here; also plenty of big game. House has been entirely refurnished; rooms have hot and cold water and baths. Grounds nicely graded, tennis court, croquet grounds and many fine woods roads laid out. Fishermen can avoid expense of guide by coming here, although we furnish guides, boats and canoes when desired. Several camps in our "string," all snug and attractive. Rates \$2.00 to \$2.50 per day. Descriptive Booklet sent free.

### **At OUTLET HOUSE**

(Formerly Moosehead House), MOOSEHEAD, ME. 11 miles from Greenville by C. P. R. R. or by Steamer.

**CHARLES E. WILSON - Propr.**

New steamboat just bought to accommodate our guests.

10c.

SEND  
FOR  
IT

### **"Haunts of the Hunted"**

Published by the

### **Bangor & Aroostook R. R.**

*Entirely new Guide book for 1903, descriptive of Northern Maine. Book of 200 pages, finely illustrated by more than 100 half-tone cuts and with two full pages in colors. Write to Dept. H and enclose 10 cents in stamps.*

**GEO. M. HOUGHTON,**  
Traffic Manager  
BANGOR, ME.

## **Queen of Summer Trips**

### **BALTIMORE TO BOSTON AND PROVIDENCE**

BY SEA VIA

### **MERCHANTS AND MINERS TRANS. CO.**

Accommodations and Cuisine unsurpassed. Complimentary side trip to Old Point. Send for illustrated Tour Book. Steamers leave Baltimore daily for the East. For further information address W. P. TURNER, Gen'l Pass. Agent, Baltimore.

## **Chatham Beach Hotel**

Chatham, Mass., affords the finest shore bird shooting in New England, and being situated on a clean sand beach, one hundred feet from the Ocean, commands coolest breezes, fine view, good bathing, fishing, sailing, etc. Rates \$2.50 per day; reduced rates for families. For further particulars apply to

**N. A. ELDRIDGE - Chatham, Mass**

## Newhouse Traps

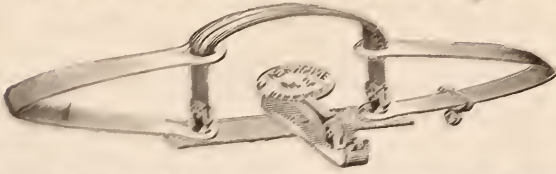

THE STANDARD FOR OVER FIFTY YEARS

Used by all professional hunters and trappers,  
who find that

**The Best Trap is the Cheapest**

Complete illustrated catalogue on  
application.

ONEIDA COMMUNITY, LTD., Kenwood, N. Y.



### "Collan-Oil"

preserves leather and  
renders shoes and  
harness positively

**WATERPROOF**

Used by the U. S.  
the Army and Navy,  
and National Guard.

Send 25c. for trial can.

AGENTS WANTED

Write for terms and circulars

J. R. BUCKELEW

Dept. A. 111 Chambers St., N. Y.

## DuPont Smokeless

AT THE

PENNSYLVANIA STATE SHOOT

(Open and State Events Combined)

Mr. J. T. Atkinson, of New Castle, won

**HIGH AVERAGE**

Breaking 495 out of 525 Targets  
Shooting

## DuPont Smokeless

### KOENIG'S SHELL EXTRACTOR.



10 Cts. Postpaid.

E. G. KOENIG, NEW JERSEY'S LARGEST GUN HOUSE

SOUTH BROAD ST., NEWARK, N. J.

Every shooter should  
have one—carry it in a  
vest pocket. Fits any  
gauge shell. Koenig's  
Gun Catalogue, Free.

### THE BRADLEY SHOT GUN SIGHT

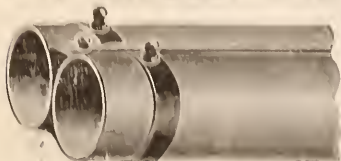

Wing Shooting is  
made easy and cer-  
tain by using this gun  
sight. Scores at trap  
and in field greatly  
increased by its use.  
Right and left birds  
are bagged as easily

as straight-away birds. Price 50 Cents, Postpaid.

C. L. BRADLEY, Inventor, Clarksville, Tenn.

### SOME GOOD GUIDES.

Following are names and addresses of guides who have been recommended to me, by men who have employed them; together with data as to the species of game and fish which these guides undertake to find for sportsmen.

If anyone who may employ one of these guides should find him incompetent or unsatisfactory, I will be grateful if he will report the fact to me.

#### ALASKA.

Edwin Edelman, Kenai, Cook's Inlet, moose, bear, caribou, mountain sheep, ducks, grouse and trout.

#### FLORIDA.

Carson Bros., Frostproof, bear, deer, turkeys, quail, snipe.

C. H. Stokes, Mohawk, deer, alligators, turkey, quail, and snipe.

#### IDAHO.

John Ching, Kilgore, elk, bear, deer, antelope, mountain sheep, trout and grouse.

Chas. Petty's, Kilgore, ditto.

#### MAINE.

H. R. Horton, Flagstaff, deer, bear, moose, caribou, fox, grouse and trout.

W. C. Holt, Hanover, moose, caribou, deer, grouse and trout.

#### MONTANA.

A. R. Hague, Fridley, elk, deer, mountain sheep, bear, grouse and trout.

Chas. Marble, Chestnut, ditto.

#### NEW YORK.

Le Roy Still, Bayport, Long Island, ducks, quails, rabbits and grouse.

#### WYOMING.

S. N. Leck, Jackson, elk, bear, deer, mountain sheep, antelope, grouse and trout.

James L. McLaughlin, Valley, elk, bear, deer, mountain sheep, antelope, grouse and trout.

#### CANADA.

Wm. S. Andrews, Lillooet, B. C., deer, bear, mountain sheep, goats, grouse and trout.

B. Norrad, Boiestown, N. B., moose, caribou, grouse and trout.

Carl Bersing, Newcastle, N. B., moose, caribou, deer, bear and grouse.

## Big Game Hunters

FISHING AND OUTING PARTIES

Before planning trips other than in New Brunswick, should apply to

**The New Brunswick Guides Association**

Fredericton, New Brunswick, Canada,

for information. The Association comprises the leading and most reliable guides in the Province.

## Hunting Map of New Brunswick

Showing rivers, lakes, portage roads, carries, etc. Scale, 4½ miles to the inch, and folded to suit pocket. Mailed to any address on receipt of price, \$1.50. Checks accepted.

FRANK WHITEHEAD,

Fredericton, New Brunswick,

P.O. Box 303

Canada.

## George Stables

Dealer in Fancy Groceries, etc. Sportsmen's Provisions a specialty.

Only the best quality goods kept in stock. Prices on application. **Public Square, Newcastle on the Miramichi, NEW BRUNSWICK.**

**For Sale or Exchange**—A scholarship of complete course in electrical engineering at International Correspondence Schools, Scranton, Pa.

J. E. Jones, Atoka, Indian Territory.

## FORTY-EIGHT PAGES

are required just to describe a lot of interesting booklets of travel, any one of which can be obtained by sending a few cents in stamps. These forty-eight pages make the

### ILLUSTRATED CATALOGUE

OF THE

### NEW YORK CENTRAL'S

### "FOUR-TRACK SERIES"

Embracing 37 Books of Travel.

A copy of this catalogue will be sent free, post-paid to any address, on receipt of a two-cent stamp, by

**GEORGE H. DANIELS,**  
Gen'l Passenger Agent,  
Grand Central Station, New York.

10c. SEND  
FOR  
IT

## "Haunts of the Hunted"

Published by the

## Bangor & Aroostook R. R.

*Entirely new Guide book for 1903, descriptive of Northern Maine. Book of 200 pages, finely illustrated by more than 100 half-tone cuts and with two full pages in colors. Write to Dept. H and enclose 10 cents in stamps.*

**GEO. M. HOUGHTON,**  
Traffic Manager  
BANGOR, ME.

## "Going Into the Woods"

IS NOW THE POPULAR FAD

### **Maine** Is the Recognized Summer Playground of the Nation

There can be found all the pleasures of Fishing, Hunting, Canoeing, Mountain Climbing and Absolute Rest.

During the summer season there are Four Express Trains daily to Bar Harbor, Three Express Trains daily to the White Mountains. One through train New York to Bar Harbor

### Through Trains to All Hunting and Fishing Resorts.

*Send for Guide, Books and Maps.*

F. E. BOOTHBY, General Passenger Agent.  
GEO. F. EVANS, Vice-Pres. and Gen. Mgr.,  
Portland, Me.

I would like to correspond with a few Sportsmen and Sportswomen relative to unexplored regions. Beautiful undisturbed Nature, pure air, pure water, big game, big fish, trout and muskalonge. One day's paddle from railroad.

**E. C. TRIPP,**  
Atikokan, Ontario, Canada, Seine River Dist.

## Queen of Summer Trips

### BALTIMORE TO BOSTON AND PROVIDENCE

BY SEA VIA

### MERCHANTS AND MINERS TRANS. CO.

Accommodations and Cuisine unsurpassed. Complimentary side trip to Old Point. Send for illustrated Tour Book. Steamers leave Baltimore daily for the East. For further information address W. P. TURNER, Gen'l Pass. Agent, Baltimore.

## Chatham Beach Hotel

Chatham, Mass., affords the finest shore bird shooting in New England, and being situated on a clean sand beach, one hundred feet from the Ocean, commands coolest breezes, fine view, good bathing, fishing, sailing, etc. Rates \$2.50 per day; reduced rates for families. For further particulars apply to

**N. A. ELDRIDGE - Chatham, Mass**

## BEST FISHING

AND

## FINE HUNTING

## At OUTLET HOUSE

(Formerly Moosehead House), MOOSEHEAD, ME. 11 miles from Greenville by C. P. R. R. or by Steamer.

**CHARLES E. WILSON - Propr.**

New steamboat just bought to accommodate our guests.

Earliest and latest Moosehead lake fishing is had here; also plenty of big game. House has been entirely refurbished; rooms have hot and cold water and baths. Grounds nicely graded, tennis court, croquet grounds and many fine woods roads laid out. Fishermen can avoid expense of guide by coming here, although we furnish guides, boats and canoes when desired. Several camps in our "string," all snug and attractive. Rates \$2.00 to \$2.50 per day. Descriptive Booklet sent free.

**A SAFE  
POWDER  
IN ANY GUN**

Robin Hood Smokeless  
is a bulk Powder.  
Try it and you will  
use no other.

**ROBIN HOOD SMOKELESS**

We make the powder, we make the shells, and we load them. Robin Hood Factory Loaded Ammunition is unexcelled in pattern, penetration, velocity and slight recoil, the four most essential points of merit in an ideal load.

**THE ROBIN HOOD  
POWDER COMPANY  
Swanton, Vt.**

Write for "Powder Facts"

J. P. Del. Williamson-Helfner & Eng. Co.

Received the Marble pocket axe. It is a beauty, more than meeting my expectations. This makes the third prize received from you, representing altogether a cash value of \$58.50. The first was an Al Vista camera; the second a Racine canoe.

W. W. Mackey, Franklin, Pa.

**For Sale:** 22 C. F. Winchester single shot Rifle, 600 cartridges and reloading tools, almost new. 32 Marlin Rim and C. F. Repeater, new, and 32 Smith & Wesson Hammerless Revolver. P. O. Box 156, Mt. Carmel, Ill.

### REMARKABLE OFFERS

To every person who will send RECREATION \$1 for 1 year's subscription to be placed to my credit I will give as a premium a choice of a Nickel Plated Match Safe, or a Gilt Metal Match Safe, or a Hard Rubber Water Proof Match Safe, each listed at 40 cents; or a Nickel Dog Whistle and pocket drinking cup, listed at 50 cents; or a Nail Clipper, with file and Nail Clipper attached, listed at 40 cents; or a 25 yard Single Action Reel, listed at 40 cents; or a 25 yard Water Proof Silk Line, listed at 50 cents.

For 2 subscriptions a Hunting Knife, Stag Handle, Blade 5½ inches long, listed at \$1.

For 3 subscriptions a Patent Double Minnow Bucket, listed at \$2; or a 60 yard Multiplying Reel, listed at \$2; or a 3-piece Bamboo Rod, 7 or 9 feet long, listed at \$2; or a Heavy Silk Watch Fob, listed at \$1.50.

For 5 subscriptions a fancy striped Hammock, listed at \$3; or a Hunting Knife, listed at \$3; or a Tackle Box, listed at \$3.

For 9 subscriptions a field glass listed at \$6.

Only a limited number of subscriptions can be accepted on these offers.

E. W. Jacobs, Coshocton, Ohio.

## Polo and Saddle Ponies

Thoroughbred Dogs and Poultry

VALLEY FARMS - - SIMSBURY, CONN.

I am a subscriber to RECREATION, as well as to nearly a dozen other sportsmen's periodicals. While a few refuse to indorse the method of roasting that you employ, it has my support at least. I notice also that some writers of articles to the daily press use terms that lead me to believe RECREATION has left its ear-marks on either them or their friends. You are doing great things for the cause of game protection. I wish you a long life in the work you have undertaken, but I trust, at the same time, it may not take you a lifetime to accomplish it.

Redfood, Redlands, Cal.

## EVERY TRUE SPORTSMAN Needs a Course in Taxidermy

OUR SCHOOL FILLS THIS NEED. SPORTSMEN, GUNNERS, ALL LOVERS OF NATURE—we can teach you to mount all kinds of birds, animals, reptiles, fishes, head and antlers, in fact, we teach the whole subject of Taxidermy by mail with remarkable success. Nothing is more beautiful for den or office than well mounted natural specimens.

### We Tell You How to Pay All Gun and Sporting Expenses

If you shoot and can not save your specimens, you are losing the best part of field sports. Tuition reasonable. We are the originators of Taxidermy Schools. We want every reader of RECREATION to have our literature—FREE. Write us today, before you forget it; a postal card will do. Mention RECREATION. Yours for true sportsmanship,

**THE NORTHWESTERN SCHOOL OF TAXIDERMY, Omaha, Nebraska**

*The Original and Only School of Its Kind*



## IDEAL PAPER SHOT SHELL TRIMMER SOMETHING NEW.

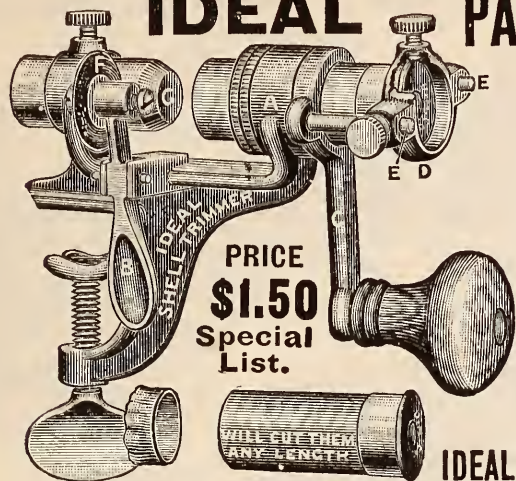

PRICE  
**\$1.50**  
Special  
List.

With it you can cut off the soft and frayed ends of shells that have been fired and they will be *as good as new*. Why throw *good shells away*? Send us 6 cents in stamps for *latest IDEAL HAND BOOK*, giving full information of all *New Goods* and much matter of interest to shooters. Address,

IDEAL MANUF'G CO., 12 U St., New Haven, Conn., U.S.A.

THE PHIL. B. BEKEART CO., of San Francisco, Cal., Agents for Pacific Coast.

When you write please mention Recreation.

## THE "BROWNIE" RIFLE

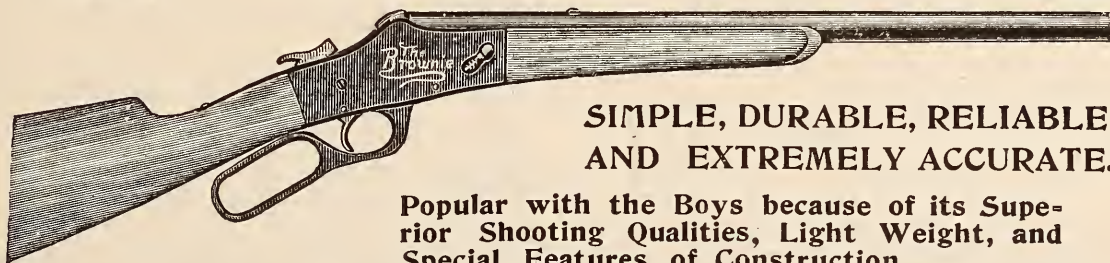

SIMPLE, DURABLE, RELIABLE,  
AND EXTREMELY ACCURATE.

Popular with the Boys because of its Superior Shooting Qualities, Light Weight, and Special Features of Construction

Furnished in 22 caliber only. Weight  $4\frac{1}{4}$  to  $4\frac{1}{2}$  pounds. It is supplied by RECREATION as a Premium.  
Write for Catalogue

The W. H. Davenport Fire Arms Co., Norwich, Conn.

## PITTED ARMS AREN'T ACCURATE



Wick Plugs prevent Pits and Rust

Rifle—30 to 50 caliber, 75c. each postpaid.

Shotgun—10 to 20 gauge, \$1.00 each,

\$1.75 per pair, postpaid. Give length and gauge.

**HEMM & WOODWARD, Sidney, O.**

Write for descriptive circulars. Mention RECREATION.

## WANTED

Every owner of a shot gun to learn all about our handy little  
Target Trap.

*A Card Brings the Information*

Mention RECREATION.

THE MITCHELL MFG. CO., London, Ohio



**No. 4**  
**\$100**  
**LIST**  
**ITHACA**

**THE NITRO BREECH SHOWING NEW CROSS BOLT**

**GUARANTEED to be worth \$25.00 more than any other make of Gun at Same Cost.**

Send for Catalogue Describing Sixteen Different Grades of Guns, Ranging in Price from \$19.50 to \$300.

**ITHACA GUN CO., Ithaca, N. Y.**  
 Mention RECREATION.



We make a specialty of Featherweights and Trap Guns with our new **SINGLE TRIGGER**

Send stamp for 1903 Catalogue  
 Mention RECREATION

**D. M. LEFEVER SONS & CO.,**  
 Manufacturers of the "NEW LEFEVER"  
 SYRACUSE, N. Y.

Not connected with Lefever Arms Co.

Guaranteed Perfect  
 Our New Perfect Gun Cleaner By Mail, 30 Cents

**THE BAKER**  
 THE GUN THAT'S SAFE

**SO DURABLE TOO IT LASTS A LIFETIME**



If you want to be right up in the front rank of style and efficiency shoot one of our **Special Paragons** with *Whitworth* or *Krupp fluid steel* barrels. We have other patterns also that would please you. Our "Quarterly" tells about them and other matters that would interest you. We will send it to you *free a year* if you want it.

**BAKER GUN & FORGING CO., 42 Liberty Street, Batavia, N. Y.**



**WANT  
A LIGHT?**

Every sportsman knows the value of dry matches. They're always a comfort; sometimes they save lives.

**THE RECREATION  
WATERPROOF MATCHBOX**

is the *only* waterproof matchbox ever offered sportsmen which is worth pocket room.

It is substantially made from brass, heavily nickeled, and holds enough matches to keep a man in smokes and fires for several days.

**Price 50 cents.** For sale by dealers everywhere. or  
**Marble Safety Axe Co., Gladstone, Mich.**

*Marble's Safety Pocket Axes.  
Marble's Automatic Gaff Hook.  
Marble's Compass and Bracket.  
Marble's Ideal Hunting Knife.*

Send for  
Catalogue A  
**FREE**

Cut  
 $\frac{2}{3}$   
size



Shows  
box  
closed

FREDERICK SCOTCFORD-CHICAGO

**A Broken  
Hunting Knife.**



A few days ago the newspapers told the story of the discovery of the skeleton of a man—evidently a hunter—who perished in a hand to hand fight with a bear *because his hunting knife broke.*

**Marble's Safety Pocket Knife**

cannot break. It is hand forged from the best selected steel. Folds when not in use, yet locks perfectly rigid when open—not a toy, but a knife to stake a life on. Price \$4.00 from all dealers or direct from the manufacturers.

Send for catalogue A.

**MARBLE SAFETY AXE CO., GLADSTONE, MICH.**

**Practical Common Sense  
in 6 Sizes.**

**CAMP  
STOVE**

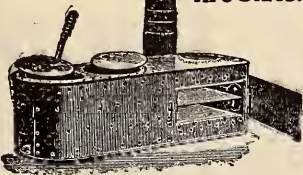

Either with or without oven. The lightest, strongest, most compact, practical stove made. Cast combination sheet steel top, smooth outside, heavy lining in fire

box and around oven, holds its shape, telescopic pipe carried inside the stove. Burns larger wood and keeps fire longer than any other. Used by over 9,000 campers and only one stove returned.

For catalogue giving full particulars, mention RECREATION and address.

**D. W. CREE, Manufacturer, Griggsville, Ill.**

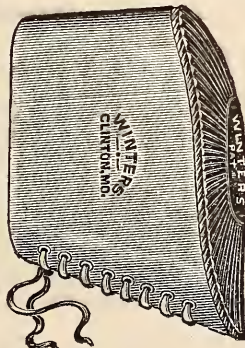

**THE  
1902 Model**

**LEATHER-COVERED** Pneumatic Recoil Pad is now perfect. No pump, no valve, no recoil, no flinch, no headache, no bruised shoulders, no money if not satisfactory and returned at once. **PRICE \$2.**

**J. R. WINTERS  
Clinton, Mo.**

**THE PARKER  
AUTOMATIC  
EJECTOR**

The Latest attachment to  
**The "OLD  
RELIABLE"**



New York Salesroom, Send for Catalogue. **PARKER BROS.,**  
32 WARREN ST. Mention RECREATION. Meriden, Conn.

H. & R.

# "Bicycle Hammerless" Revolver

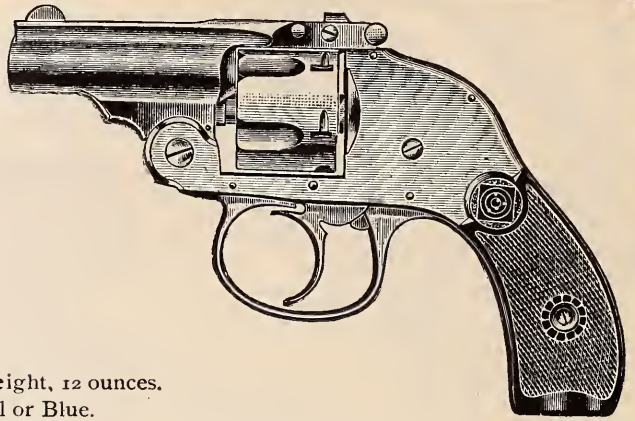

**Description**

32 Caliber, 5 shot. 2 Inch Barrel. Weight, 12 ounces.  
C. F., S. & W. Cartridge. Finish, Nickel or Blue.

**IMPOSSIBLE TO CATCH** on the pocket and discharge accidentally. **ABSOLUTELY SAFE.** Although designed for cyclists, this revolver is equally adapted to all cases where a small, light weight, effective and handy pocket weapon is desired. It has small frame and automatic ejector. Sold direct where dealers will not supply.

## HARRINGTON & RICHARDSON ARMS CO.

Makers of H. & R. SINGLE GUNS

Catalog for Postal  
Dept. R.

**WORCESTER, MASS.**

# MAUSER 8m-m and 9m-m

High Power Rifles. Suitable for Large  
Game Shooting

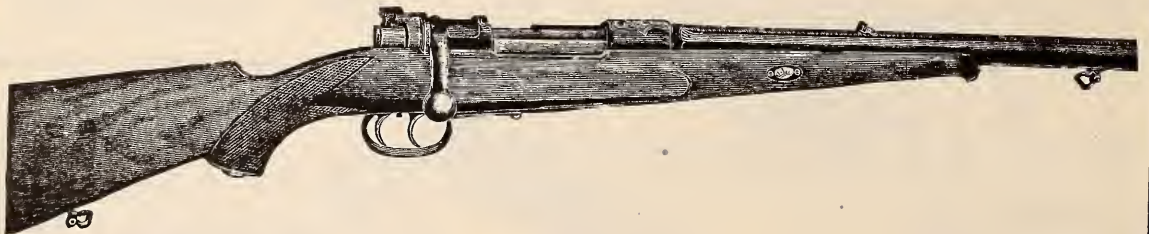

Made by J. P. Sauer & Sohn and V. C. Schilling

Prices, \$25.00 to \$50.00

## SCHOVERLING, DALY & GALES

302-304 Broadway,

New York

Specialty Catalogue mailed on receipt of Five Cents.

# "HOPKINS & ALLEN" Single Barrel Shot Guns

(Made for any powder and good for any shot.)

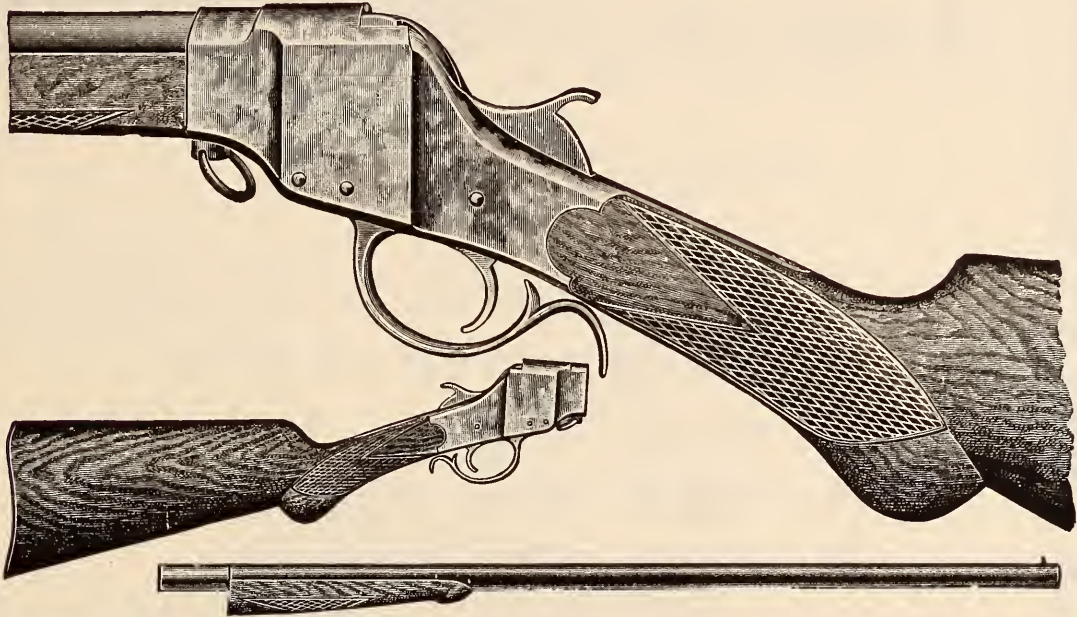

Our "Lever Action" has more friends than any single gun made, has stood the test of fifteen years' continued approval. Simple, durable and reliable, 12 and 16 gauge blued steel barrel..... **\$8.00**



MODEL F.  
MADE BY  
HOPKINS & ALLEN ARMS CO.  
NORWICH, CONN.

Our new model top snap action, combining all up-to-date features of a modern gun, including patent compensating snap fore end. Automatic shell ejector, **Full Choke Bored.** 12, 16 and 20 gauge decarbonized steel barrel..... **\$9.00**  
12 and 16 gauge Stubbs twist steel barrel..... **\$10.00**

*We will ship, all charges prepaid, on receipt of remittance with order, to any express office in the U. S. A.*

**The Hopkins & Allen Arms Co.,**  
NORWICH, CONN., U. S. A.

Are You an  
Amateur  
Photographer?



If so would you like a Camera  
that will photograph

A whole range of mountains  
A whole sweep of river  
A whole army  
A whole fleet of ships  
A whole city

Or any other vast stretch of scenery or moving  
objects? THE SWING LENS DOES IT

The **Al Vista**

Is the thing. It lists at \$30.

---

One of the greatest inventions of the age.  
Given as a premium for 12 subscriptions,

---

For particulars Address

**RECREATION**

23 West 24th Street

NEW YORK CITY

Guaranteed NOT to Shoot Loose.

Any  
One of the **9**

# “SYRACUSE”

Built for Business.

Whether Grade “OO” listing at \$30.00  
or Grade “D” listing at \$475.00.

Made in  
10-12-16 and 20 Gauge

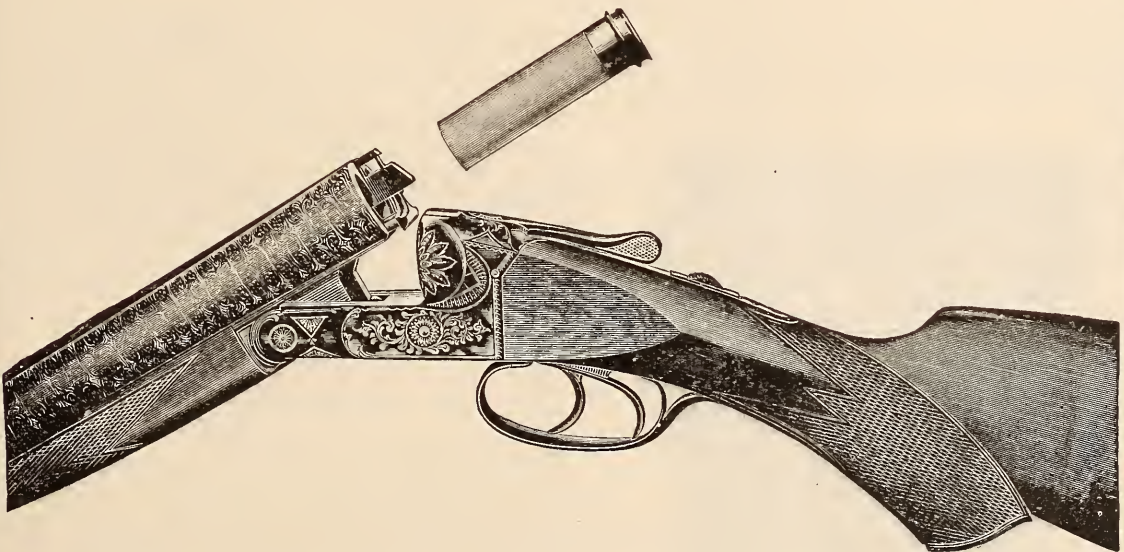

HAVE the STRONG shooting qualities that has brought  
the “SYRACUSE” into such PROMINENCE.

The careful INSPECTION and ATTENTION to detail  
that has gained for the “SYRACUSE” the name of the  
“THOROUGH-BRED”

The EXQUISITE lines      The SUPERB balance  
that denotes the work of the Master Crafts-man.

BUILT BY

**SYRACUSE ARMS CO.,**

**SYRACUSE, N. Y.**

“SYRACUSE CATS” are TAME CATS and yours for the asking.

Mention RECREATION.



THE  
WORLD'S  
STANDARD



THEY'RE MADE TO MEASURE

# Putman Boots.

Go on like a glove *and* fit all over.

For a **Quarter of a Century** Putman Boots have been the Standard among Western Hunters, Prospectors, Ranchmen and Engineers (who demand the best) and we have learned through our personal contact with them **how** to make a perfect boot.

Putman Boots are in use in nearly every civilized country in the World. They are Genuine Hand Sewed, Water proof, Made to measure, Delivery charges prepaid, and cost no more than others. Send for Catalogue of over **30 different styles** of boots. Also **Indian Tanned Moosehide Moccasins**. We send with catalogue Order Blanks showing how to measure your foot.

We have in our files thousands of letters similar to the following.

**GENTLEMEN:**—Please send me another catalogue. We are all wearing Putman Boots and find them far superior to any other boot. I have ordered about 20 pairs for friends here during the past three years, and every pair has given perfect satisfaction, and I feel that I have done a man a favor when I have recommended your goods to him. Respectfully,

W. H. FLUKER, Gen. Mgr,  
(Columbia Mining Co.)  
Tatham, Ga.

**GENTLEMEN:**—I have just returned from a duck hunt in Colleton Co. this state, and though I tramped through the marshes for six days and a part of the nights, sinking in mud and water nearly to the tops of the shoes I got from you, my feet kept dry throughout the trip and the shoes were as soft at the wind-up as at the beginning. I can cheerfully recommend your shoes to all sportsmen. Yours respectfully,

C. F. DILL,  
Greenville, S. C.

**GENTLEMEN:**—Was fishing through the ice on the Flathead River this week standing for hours in wet snow and slush and tramping through the mountains, and I found the boots you built for me in December to be thoroughly water and snow proof, and quite warm. Yours truly,

L. R. FOGLE, Great falls, Mont.

Illustration shows  
No. 900, 14 inch  
Boot, made to measure  
and delivered  
in U. S. for

**\$7.50.**

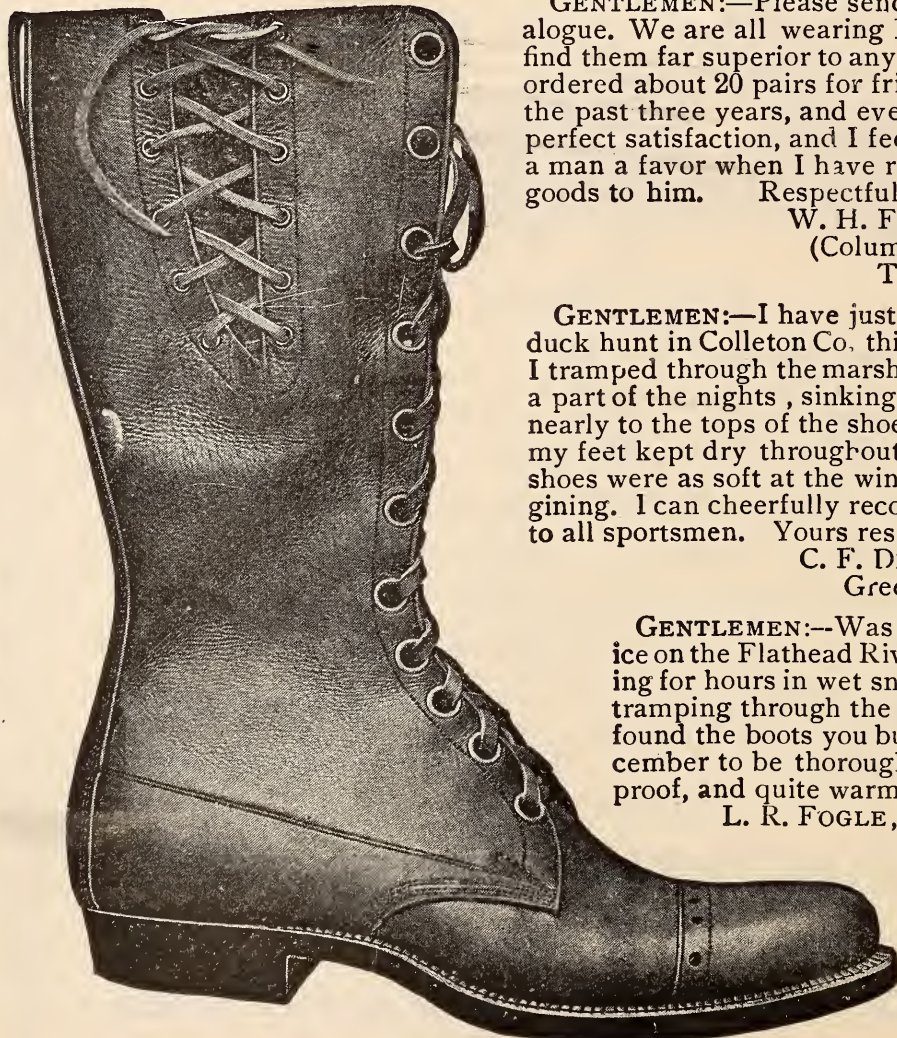

**H. J. PUTMAN & CO.,**

30 HENNEPIN  
AVE.

**Minneapolis, Minn.**



# Libby's



## For Dainty Luncheons

There is nothing so tempting and satisfying as Libby's Luncheon Meats. There are many delicious ways Libby's Peerless Dried Beef, Potted and Deviled Ham, Chicken Loaf and Veal Loaf can be served indoors and outdoors.

### Libby's (Natural Flavor) Food Products

Send for our book, "How to Make Good Things to Eat."  
Libby's Atlas of the World sent postpaid for five 2c stamps.

**Libby, McNeill & Libby**  
Chicago

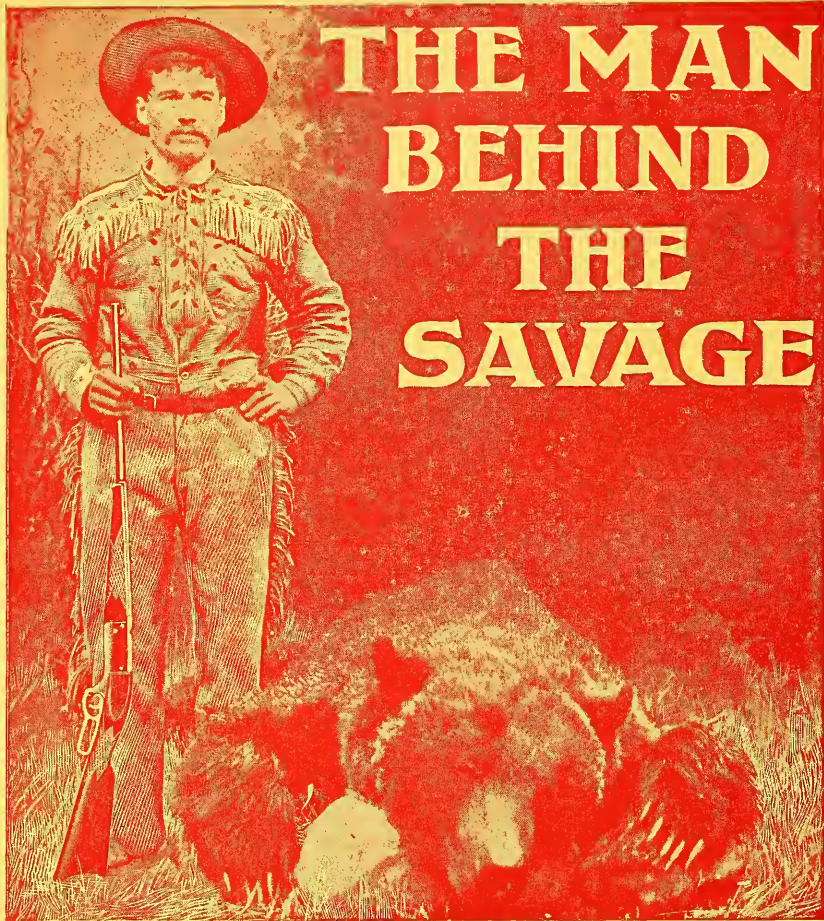

# THE MAN BEHIND THE SAVAGE

THE supreme confidence users of Savage Rifles feel when hunting big game results in the most successful shots. There is no nervousness over the chance of your rifle misfiring, clogging or shooting inaccurately. Why the most famous hunters of large and dangerous game pin their faith to a Savage is not due to any matter of sentiment—they know by actual experience the superiority of the Savage System.

Catalogue (G) on request.

**SAVAGE ARMS  
COMPANY**

Utica, N. Y., U. S. A.

BAKER & HAMILTON  
Pacific Coast Agents  
San Francisco and Sacramento, Cal.

# \$ Think Money

**BIG MONEY MAKERS  
THINK MONEY**

A strong, well-fed and well-nourished brain is absolutely essential.

The brain food GRAPE-NUTS was made for a purpose.

It was made by a skilled food expert.

It does what it is intended to do. You can get certain results by a steady use of GRAPE-NUTS.

**The food for thought**

**IF QUALITY COUNTS  
IT'S**

*Auyler's*

**YOU WANT.**



**"THE COCOA  
OF QUALITY."**

**YOUR GROCER HAS IT.**

**VOSE** PIANOS have been established over 50 YEARS. By our system of payments every family in moderate circumstances can own a VOSE piano. We take old instruments in exchange and deliver the new piano in your home free of expense. Write for catalogue D and explanations.

VOSE & SONS PIANO CO., 160 Boylston St., Boston, Mass.

JUL 08 1903

VOLUME XIX.  
NUMBER 2

AUGUST, 1903

\$1.00 A YEAR  
10c. A COPY

TARPON FISHING AT PASS CHRISTIAN; By M. SNOWDEN. Illustrated with Photos.

# RECREATION

OFFICIAL ORGAN OF THE LEAGUE OF AMERICAN SPORTSMEN

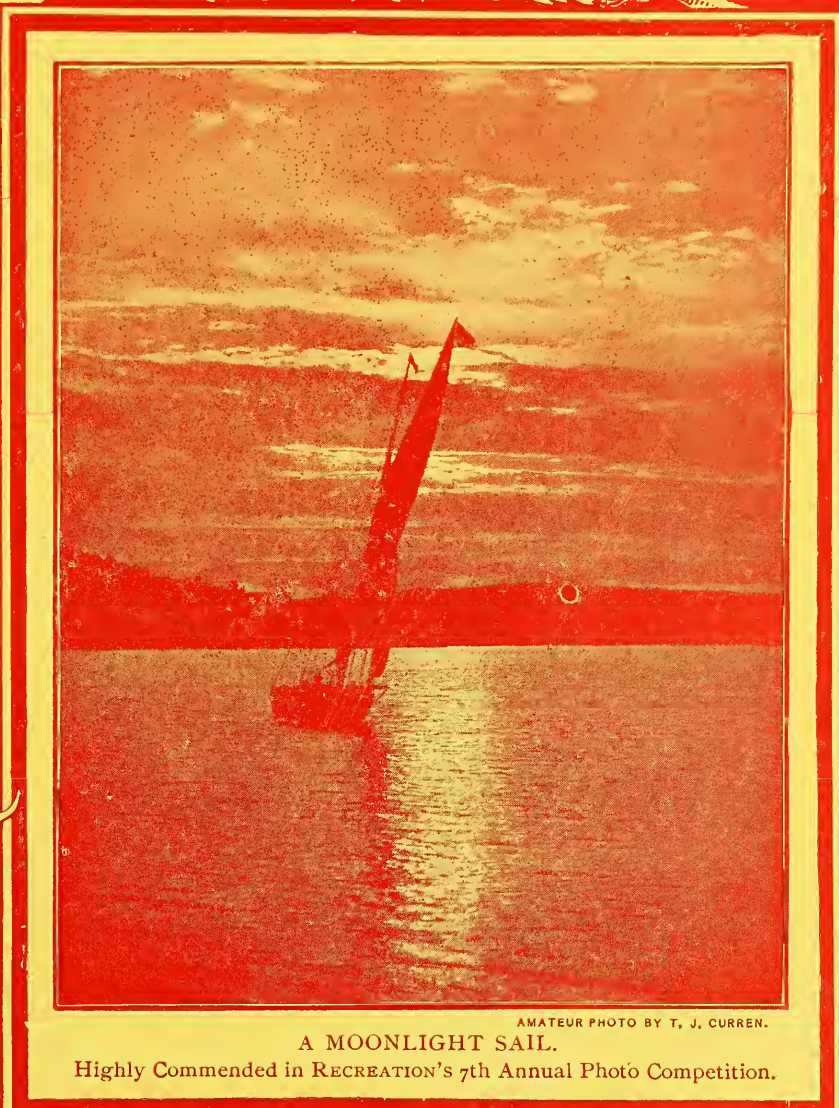

PUBLISHED BY G. O. SHIELDS (COQUINA)  
23 WEST 24TH ST., NEW YORK

THE GIANT BROWN BEARS OF ALASKA;  
By J. A. LORING. Illustrated with Photos.

There comes a time in the life of every individual when the use of a stimulant is not only advisable but necessary

As you approach the calm and mellow evening of your life you have doubtless learned the value of a pure and wholesome cereal stimulant to sweeten solitude and keep off the blues.

When choosing a stimulant for medicinal use or purpose of good cheer endeavor to obtain a mild soothing amiable fluid that does not inflame or excite, but gently stirs and quickens the life current.

REGISTERED AND SPECIAL BRANDS

<p><b>Holiday Pure Rye</b> - 4.00 (Eleven Years Old)</p>	<p><b>Old Gold Bourbon</b> - \$4.00 (Eleven Years Old)</p>
<p><b>Hermitage Rock &amp; Rye</b> 4.00 <i>Superior</i> Five pounds of rock candy crystals to each gallon of seven year old Hermitage Rye whiskey, is used in the preparation of our Celebrated Rock and Rye.</p>	<p><b>Jewel Port</b> - 4.00 From Silva &amp; Cosens, Oporto. A choice product of the grape.</p>
<p><b>Bon Ton Cocktails</b> - 4.00 Martini, Manhattan, Vermouth, Whiskey, Tom Gin and Holland Gin. Carefully prepared from the choicest materials, perfectly blended.</p>	<p><b>Rainbow Brandy V.O.</b> 4.00 The product of one of the best American Vineyards, with all the medicinal qualities of French Brandy.</p>
<p><b>Ruthven Sherry</b> - 4.00 From Duff, Gordon &amp; Co. Warranted twenty years in the wood before bottling. Rich and fruity.</p>	<p><b>Jupiter Gin</b> - 4.00 From the Swan Distillery, Schiedam, Holland, where Good Gin comes from. Tastes differ. Many people appreciate Good Gin. Jupiter is the best the world affords.</p> <p><b>Medford Old Rum</b> - 4.00 From Daniel Lawrence &amp; Sons, Medford, Mass.</p>

On receipt of your order with \$6.00, we will ship 6 full quarts assorted to suit, transportation charges prepaid, to any railroad point in the United States where the charges for transportation do not exceed \$2.00. You cannot afford to let this chance go by. You never before had as good an offer.

If you accept our offer you will surely receive the **BEST** and the **MOST** for your money that ever came to you from any similar proposition.

Remit cash in registered letter or by express company or P. O. money order.

*References:* Any bank in Boston. Any mercantile agency or any distiller of importance in the United States.

**W. H. JONES & CO.,** Hanover & Blackstone Sts.,  
BOSTON, MASS.

ESTABLISHED 1851

# RECREATION

Copyright, December, 1902, by G. O. Shields

A Monthly Magazine Devoted to Everything the Name Implies

\$1.00 A YEAR.  
10 CENTS A COPY.

G. O. SHIELDS (COQUINA),  
Editor and Manager.

23 WEST 24TH STREET,  
NEW YORK

## CONTENTS OF THIS NUMBER

	PAGE
The Bulls Stood Still and Gave Me a Chance for Another Shot.....	FRONTISPIECE.
Hunting Blue Bulls in India. Illustrated.....	W. H. FEE 85
Loon Notes and Queries. Illustrated.....	ROBERT J. SIM 89
The Giant Brown Bears of Alaska. Illustrated.....	J. A. LORING 91
Tarpon Fishing at Pass Christian. Illustrated.....	M. SNOWDEN 95
A Tragedy. Poem.....	A. L. VERMILYA 96
An Interesting Summer Boarder. Illustrated.....	J. H. FISHER, JR. 97
In the Woods with Rod and Camera.....	F. W. HALSEY, M.D. 100
A Trip for Trout. Illustrated.....	DR. J. S. EMANS 103
Tenderfeet in the Grand Discharge.....	ROBERT FROTHINGHAM 107
Wild Sheep in Captivity. Illustrated.....	HARRY E. LEE 112
The Battle of the Prong Horns.....	W. T. HEDDON 113
From the Game Fields.....	115
Fish and Fishing.....	127
Guns and Ammunition.....	131
Natural History.....	139
The League of American Sportsmen.....	143
Forestry.....	147
Pure and Impure Foods.....	149
Publisher's Notes.....	151
Editor's Corner.....	152
Amateur Photography.....	156

Entered as Second-Class Matter at New York Post-Office, Oct. 17, 1894.



## WELL DRESSED MEN

appreciate the great utility and  
comfort of

### WASHBURNE'S PATENT SCARF HOLDER

Little but effective. It cannot come loose or  
ride up. Instantly attached and detached.

Scarf Holder - - -	10 Cents	} Sent Pre- paid.
Cuff Holders - - -	20 "	
Key Ring and Chain - - -	25 "	

They never come loose. A tiny lever with  
a bulldog grip. Illustrated Catalogue Free.

AMERICAN RING CO., Dept. 44  
Waterbury, Conn.

## Skin Diseases

Eczema, Salt Rheum, Pimples, Ring-  
worm, Itch, Ivy Poison, Acne or other  
skin troubles, can be promptly cured by

# Hydrozone

Hydrozone is endorsed by leading phy-  
sicians. It is absolutely harmless, yet  
most powerful healing agent, that cures  
by destroying the parasites which cause  
these diseases.

**Cures sunburn** in 24 hours. In cases of  
Prickly Heat and Hives it will stop itch-  
ing at once, also will relieve mosquito  
bites instantly. Take no substitute and  
see that every bottle bears my signature.

**Trial Size, 25 Cents.**

At Druggists or by mail, from

*Prof. Charles Marchand*

F-59 Prince St., New York.

FREE {Booklet on the rational treat-  
ment of diseases sent free.

# Waltham Watches

Known by their works.

*“The Perfected American Watch,” an illustrated book of interesting information about watches, will be sent free upon request.*

*American Waltham Watch Company,  
Waltham, Mass.*

Established 1840

**GEO. B. CARPENTER & CO.**  
MAKERS OF HIGH GRADE  
**TENTS, SAILS  
CAMP FURNITURE**

Folding Cots  
Tables and Chairs

Oars, Paddles  
Marine Hardware

copyright 1899  
Geo. B. Carpenter & Co.

The Largest and Most  
Complete Stock in the U. S.

Send 4c. in stamps for Tent and Camp Catalogue, or  
6c. in stamps for Marine Hardware Catalogue.

200, 202, 204, 206, 208 S. Water St.  
CHICAGO, ILL.

SAILING. CAMPING. PROSPECTING. FISHING. HUNTING.



THE OLD WAY

**T**HE BOAT as pictured below in every detail—length 15½ feet, beam 4 feet, with ¾ horse-power Blomstrom gasoline engine

**\$100**

*So simple a child can operate  
with entire safety*

Catalogue D, including Marine Gasoline Engines of from ¾ to 80 horse-power at corresponding prices, free on request.

**THE C. H. BLOMSTROM MOTOR CO.**  
1284-1294 River Street, Detroit, Mich.

*(From the Chicago Journal, May 7th).*

At last an honest soul has put a 15½ foot launch with gasoline engine—4 foot beam—within the reach of the masses.

THE NEW WAY



**"NOTHING SO RARE AS RESTING ON AIR."**



TAKING MINE EASE.

The only article in your outing outfit that you can use during the whole year is a

# Pneumatic Mattress OR CUSHION

## THE EVER PRESENT ROOT

in the bed of boughs is a thing of the past if you use a Pneumatic Mattress. A mattress for home use that you can deflate, pack in your grip and take with you into camp.

## SPRUCE BOUGHS

may make a fine bed. But the genuine Sportsman prefers a Pneumatic Mattress because he knows he can do three times the tramping the day following a night's good sleep.

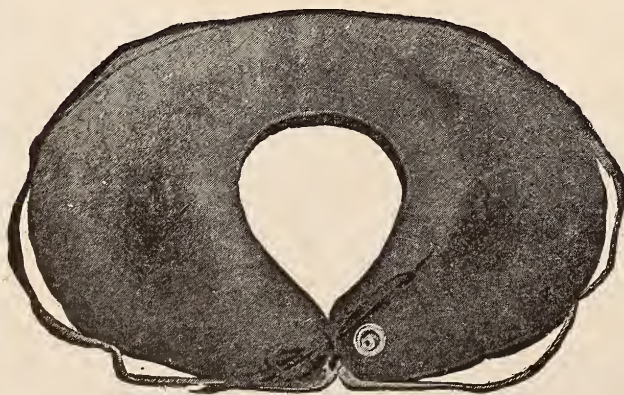

PRICE \$2.00

Carry it in your Pocket, it weighs just One Pound.

## Swimming Collar.

Worn around the neck, leaving the arms free for action. Will support a full-grown man. Just the thing when learning to swim.

Price, Small Size, \$1.50 Large Size, \$2.00

## Sportsman's Cushion

A Yoke to save your shoulders

A Swimming Collar for those who can't swim.

A Life Preserver in case of accident.

A Cushion while waiting for Moose.

A Cushion or Head Rest while waiting for Duck.

A Protection for your shoulder if the gun is heavy.

A Cushion for CAMP, BOAT, OFFICE or HOME.

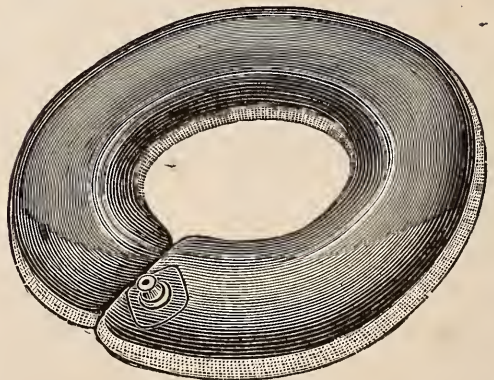

Swimming Collar.

Pneumatic Mattress & Cushion Company,

2 R South Street, New York City.



# Abercrombie & Fitch

World's  
Headquarters  
for  
Fishing Tackle



## A 3 Cent Bait

in postage stamps will bring the biggest catch an angler, camper or sportsman can land—Abercrombie and Fitch's catalogue R, 160 pages, cuts and prices.

We guarantee to furnish a more satisfactory fisherman's outfit than can be obtained elsewhere.

**Complete outfits for explorers, campers and prospectors. Camp outfits from the most modest and practical to the most complete and luxurious.**

Compare our prices on tents, clothing, cooking outfits, folding buckets, camp packs, cots, chairs, food bags, folding shelves, guns, boots, moccasins, sleeping bags, pack saddles, stoves, pneumatic beds, cushions, duffle bags, pack harness, folding bakers, folding lanterns, rolling tables, fishing tackle, shoes, covers, &c.

314-316 BROADWAY, NEW YORK CITY

# Decorate Your Den

With a set of the most beautiful  
**Hunting and Fishing Pictures**  
 ever made.

---



---

**15 Plates. Size for Framing, 18 x 24 inches**

---



---

SUBJECTS:

<b>ELK HUNTING</b>	<b>SALMON FISHING</b>	} HY. SANDHAM
<b>MOOSE HUNTING</b>	<b>TROUT FISHING</b>	

**MALLARD SHOOTING — BLACK BASS FISHING — C. E. DENTON**

**TARPON FISHING — BLUE FISHING — FRED. S. COZZENS**

**ANTELOPE HUNTING — GOOSE SHOOTING — FRED REMINGTON**

**GROUSE SHOOTING — WILD TURKEY HUNTING — R. F. ZOGBAUM**

**MUSKALONGE FISHING — F. H. TAYLOR**

**DEER HUNTING — A. B. FROST**

**ROCKY MOUNTAIN SHEEP HUNTING — E. KNOBEL**

These 15 plates are lithographed in the true colors of nature and altogether make one of the finest series of pictures of outdoor sports ever published.

**ORIGINALLY ISSUED AT \$50 A SET**

I have bought the last of them and can furnish a complete set for 15 yearly subscriptions to RECREATION,

**Or will Sell at \$10 a Set**

I also have enlargements of the following photographs:

**ROCKY MOUNTAIN GOATS**

Published on pages 90, 91, 92, and 93 of the February issue of RECREATION,  
 \$5 a set.

**WOOD DUCK SHOOTING**

Published on page 95 of the February issue of RECREATION, \$1.50 each.

---



---

**Address: RECREATION, 23 West 24th Street, New York City**

# GET READY!



In certain portions of Quebec, in British Columbia and other Canadian provinces, the law permits moose hunting in September. This is the month of the "hunter's moon," when the big bulls are on the go day and night —

**AND YOU SHOULD BE IN THE WOODS.**

*"FISHING and SHOOTING" is a pamphlet issued by the*  
**CANADIAN PACIFIC RAILWAY**  
that gives much useful information.

**YOU MAY HAVE IT FOR THE ASKING.**

**ROBERT KERR,**

Passenger Traffic Manager,

**MONTREAL.**

# Delightful Comfort

Nowhere can a person secure more real, delightful comfort on a railway journey than on the great trains over the Lake Shore and Michigan Southern Ry.

And this is due to the equipment—always the best—excellence of road bed and nicety of track adjustment, features wherein it excels all others, and which make every mile one of comfort and pleasure.

When you have occasion to travel between Chicago and Cleveland, Buffalo, New York and Boston, by using the Lake Shore you will secure absolutely the best in travel that money can buy. For "Book of Trains" or travel information, address

A. J. SMITH, General Pass. and Ticket Agent, Cleveland, Ohio.



MANZ

THE  
**NORTH-WESTERN**  
LINE

**\$30.00**

**Colorado**

AND RETURN

First-class to Denver, Colorado Springs and Pueblo from Chicago, daily, throughout the summer, good returning October 31. Correspondingly low rates from other points.

**The Colorado Special**

fast daily train, one night to Denver from Chicago and the Central States (only two nights en route from the Atlantic seaboard), leaves Chicago daily 6.30 p. m.

A second daily train leaves Chicago 11.30 p. m. Personally conducted excursions in tourist sleeping cars.

All agents sell tickets via this route. Write for particulars to W. B. KNISKERN, P. T. M. C. & N.-W. Ry., Chicago.

**Chicago, Union Pacific and North-Western Line**

CS23



# THE FOUR-TRACK NEWS

An Illustrated Magazine  
of Travel and Education

MORE THAN 100 PAGES MONTHLY

Its scope and character are indicated by the following titles of articles that have appeared in recent issues:

Picturesque Venezuela—Illus. . . . .	Frederick A. Ober
Haunts of Eben Holden—Illus. . . . .	Del B Salmon
A Journey Among the Stars—Illus. . . . .	Frank W. Mack
In the Great North Woods—Poem . . . . .	Eben B. Rexford
Beautiful Porto Rico—Illustrated . . . . .	Hezekiah Butterworth
In Rip Van Winkle's Land—Poem . . . . .	Minna Irving
Nature's Chronometer—Illustrated . . . . .	H. M. Albaugh
Van Arsdale, The Platinudinarian-III. . . . .	Chas. Battell Loomis
The Three Oregons—Illustrated . . . . .	Alfred Holman
Ancient Prophecies Fulfilled—Illus. . . . .	George H. Daniels
The Stories the Totems Tell—Illus. . . . .	Luther L. Holden
A Little Country Cousin—Illustrated . . . . .	Kathleen L. Greig
The Mazamas—Illustrated . . . . .	Will G. Steel
When Mother Goes Away—Poem . . . . .	Joe Cone
A Little Bit of Holland—Illustrated . . . . .	Charles B. Wells
The Romance of Reality—Illustrated . . . . .	Jane W. Guthrie
Samoa and Tu'uila—Illustrated . . . . .	Michael White
Under Mexican Skies—Illustrated . . . . .	Marin B. Fenwick
Niagara in Winter—Illustrated . . . . .	Orin E. Dunlap
Little Histories—Illustrated . . . . .	
Old Fort Putnam . . . . .	William J. Lampton
The Confederate White House . . . . .	Herbert Brooks
The Alamo . . . . .	John K. Le Baron

SINGLE COPIES 5 CENTS, or 50 CENTS a YEAR

Can be had of newsdealers, or by addressing

GEORGE H. DANIELS, Publisher

Room No. 48 7 East 42d Street, New York

"Free from the care which wearies and annoys,  
Where every hour brings its several joys."

## "AMERICA'S SUMMER RESORTS"

This is one of the most complete publications of its kind, and will assist those who are wondering where they will go to spend their vacation this summer.

It contains a valuable map, in addition to much interesting information regarding resorts on or reached by the

NEW YORK CENTRAL LINES

A copy will be sent free, postpaid, to any address on receipt of a two-cent stamp, by George H. Daniels, General Passenger Agent, New York Central & Hudson River Railroad, Grand Central Station, New York.

"The King's Highway"

## TO THE GATEWAYS OF COMMERCE THROUGH THE CENTERS OF POPULATION,

adding greatly to the interest of your journey, without increasing its expense beyond what you would expect to pay for the "best," which you secure if you travel by the

NEW YORK CENTRAL LINES

A copy of "Four-Track Series" No. 13, "Urban Population in 1900," will be sent free, on receipt of a two-cent stamp by George H. Daniels, General Passenger Agent, New York Central & Hudson River R. R., Grand Central Station, New York.

"The Nation's pleasure ground and sanitarium."

## THE ADIRONDACK MOUNTAINS.

The lakes and streams in the Adirondack Mountains are full of fish, the woods are inviting, the air is filled with health, and the nights are cool and restful. If you visit this region once you will go there again. An answer to almost any question in regard to the Adirondacks will be found in No. 20 of the "Four-Track Series," "The Adirondacks and How to Reach Them," issued by the

NEW YORK CENTRAL

A copy will be mailed free on receipt of a two-cent stamp, by George H. Daniels, General Passenger Agent, Grand Central Station, New York.

## Chicago, Milwaukee & St. Paul Ry.

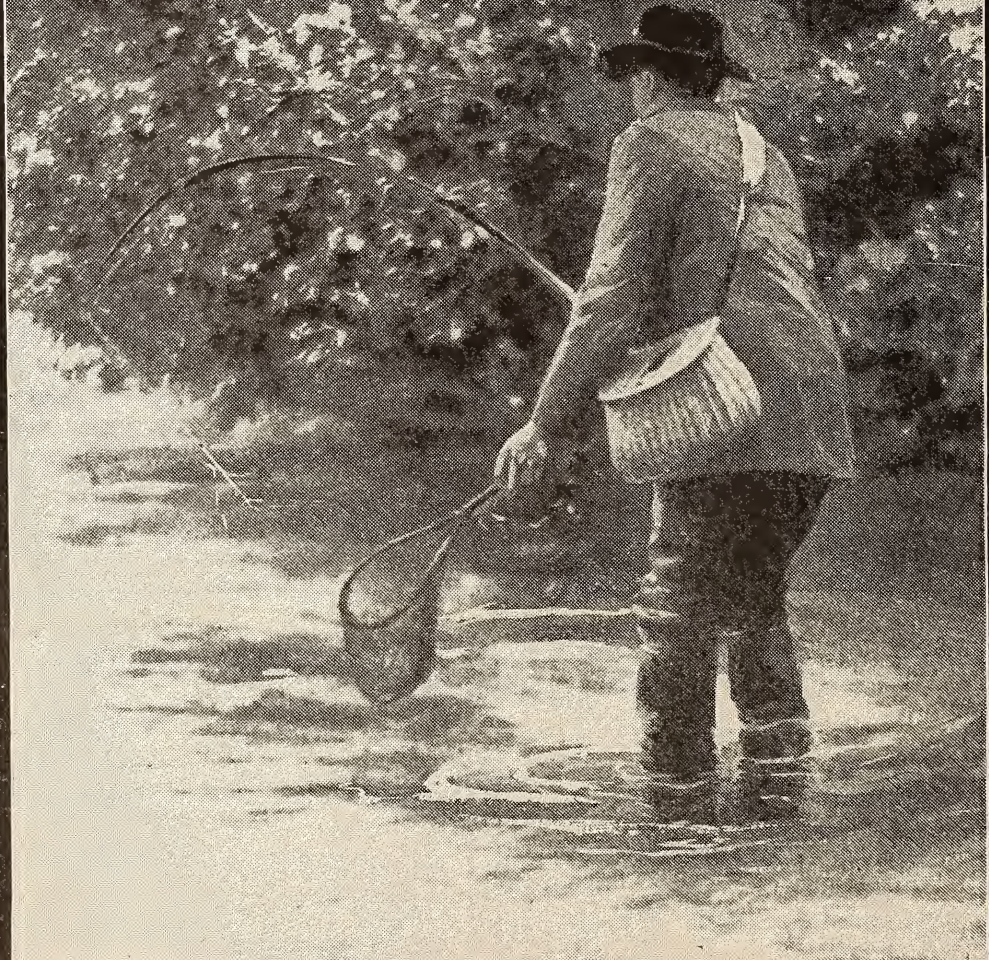

**D**IRECT to the lakes and forests of Wisconsin, Minnesota and Upper Michigan, to the vast hunting grounds beyond the Mississippi and the Missouri. Booklets and folders for two cents' postage. F. A. Miller, General Passenger Agent, Chicago.

# If the Dog Is Worth It

You ought to have your **Kennel** enclosed with

## PAGE KENNEL FENCE

It weighs 23 pounds to the rod, and is strong and handsome. If your dogs are not too large, our 58-inch Poultry Fence might answer. It weighs 10 pounds to the rod and is as strong as some stock fences. The bottom wires are only 1½ inches apart.

We make Standard Fence for every kind of farm stock. Write for descriptions.

## Page Woven Wire Fence Co.

Box 39, Adrian, Michigan

# No Picture

can show you the good qualities of the **KENWOOD SLEEPING BAG**. You must see a complete combination bag to understand how perfectly it is adapted to the use of every man who sleeps out of doors or in a tent, under all conditions of climate and weather.

If your dealer does not have the **KENWOOD SLEEPING BAG**, write us for samples, prices and full information, then decide which quality you want and order it on approval. If it does not suit you in every way return it. We pay charges both ways. Don't buy any other sleeping bag or blankets before you have seen the Kenwood.

## THE KENWOOD MILLS

ALBANY, N. Y.

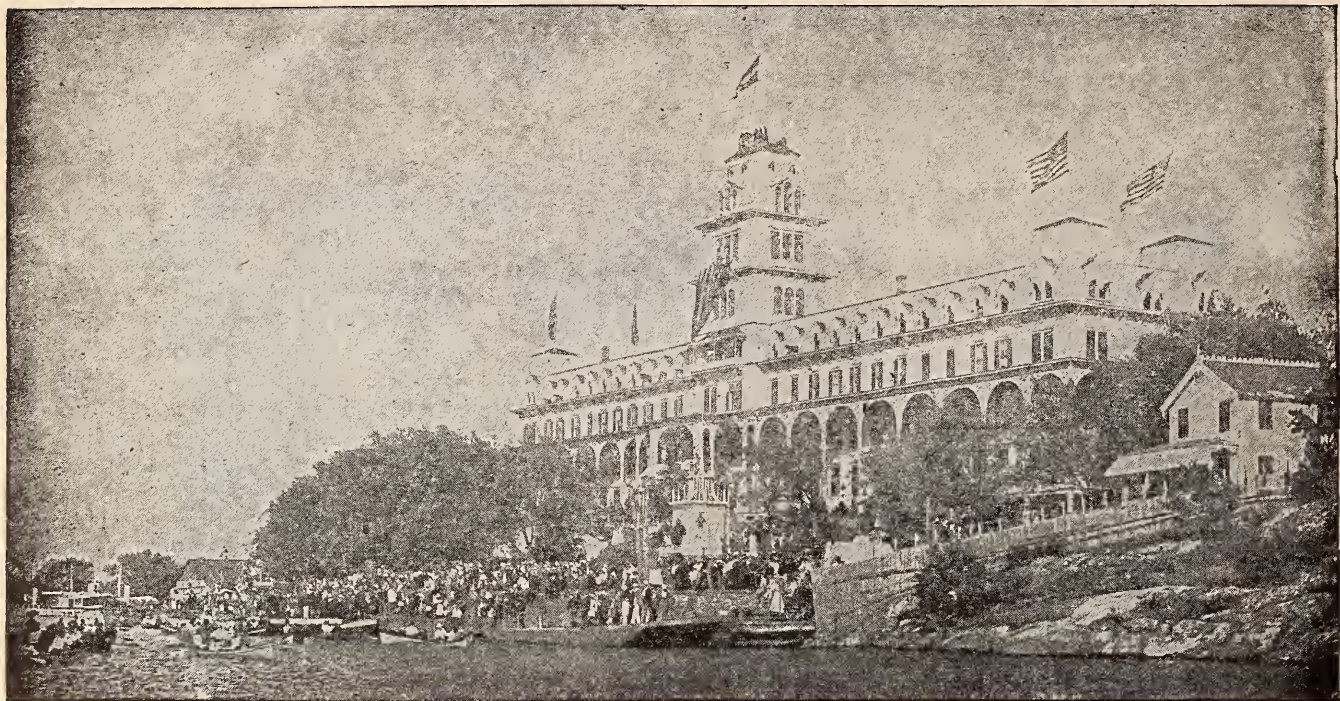

# 1000 Island House

---

---

In the midst of the "Thousand Islands," the so-called "Venice of America," and really the most charming and delightful Summer Resort on the Continent.

Send me two 2-cent stamps and I will send you a beautifully illustrated guide book. Mention RECREATION.

O. G. STAPLES, *Owner and Proprietor*

## Alexandria Bay, N. Y.



# A SUMMER PARADISE

**GRAND  
TRUNK  
RAILWAY  
SYSTEM**

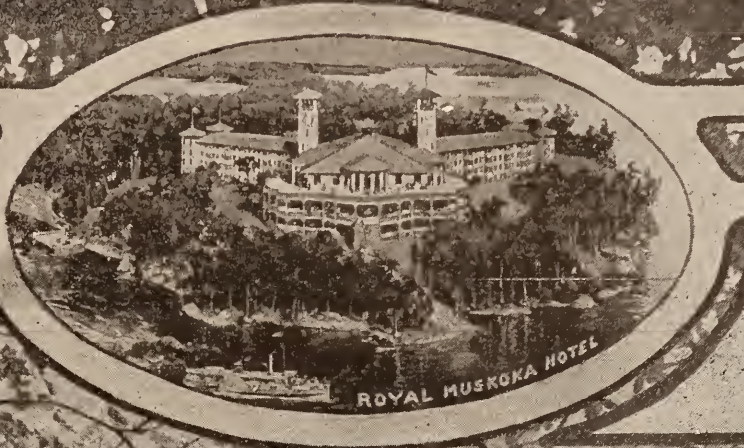

## HIGHLANDS OF ONTARIO

1000 FEET ABOVE SEA LEVEL.  
**MOST CHARMING SUMMER  
 RESORTS IN AMERICA**  
 INCLUDING  
 MUSKOKA LAKES  
 LAKE OF BAYS  
 MAGNETAWAN RIVER  
 30,000 ISLANDS OF GEORGIAN  
 BAY  
 KAWARTHA LAKES  
 LAKES SIMCOE  
 AND COUCHICHING  
 LAKE NIPISSING  
 AND FRENCH RIVER

EASY OF ACCESS. PERFECT IMMUNITY FROM MALARIA.  
 GOOD HOTEL ACCOMMODATIONS.  
 RATES TO SUIT ALL POCKETS.

**THE "ROYAL MUSKOKA"**  
 FINEST SUMMER HOTEL IN CANADA.

### FREE ILLUSTRATED PUBLICATIONS

CAN BE HAD FROM GRAND TRUNK RAILWAY  
SYSTEM. ADDRESS NEAREST OFFICE.

BOSTON, MASS.	T. Wynne,	306 Washington Street
BUFFALO, N. Y.	Chas. J. Coon,	266 Main St. (Ellicott Square Bldg.)
CHICAGO, ILL.	G. W. York,	317 Merchants Loan and Trust Building
DETROIT, MICH.	J. H. Burgis,	249 Clark St., cor. Jackson Boulevard
LOS ANGELES, CAL.	Geo. W. Watson,	124 Woodward Avenue
MONTREAL, QUE.	W. H. Bullen,	352 Wilcox Building
NEW YORK, N. Y.	J. Quilan,	Boyer's Store, 240 Broadway
SAN FRANCISCO, CAL.	W. H. Clancy,	137 St. James Street
ST. PAUL, MINN.	F. P. Dwyer,	Dun Building, 290 Broadway
TORONTO, ONT.	W. O. Johnson,	12 Front Street
	David Brown, Jr.,	111 Endicott Arcade
	J. D. McDonald,	Union Station
	J. W. Ryder,	N. W. cor. King and Yonge streets

**OR TO G. T. BELL,**  
 GENERAL PASSENGER AND TICKET AGENT.  
 MONTREAL, CANADA.

MENTION THIS MAGAZINE.



**"FOR 34 YEARS A STANDARD PIANO."**

# THE WING PIANO

**YOU NEED THIS BOOK** IF YOU INTEND TO BUY A PIANO. A book —not a catalogue— that gives you all the information possessed by experts. It makes the selection of a piano easy. If read carefully, it will make you a judge of tone, action, workmanship and finish; will tell you how to know good from bad. It describes the materials used; gives pictures of all the different parts, and tells how they should be made and put together. It is the only book of its kind ever published. It contains 116 large pages, and is named "**The Book of Complete Information About Pianos.**" We send it free to anyone wishing to buy a piano. Write for it.

**SAVE FROM \$100 TO \$200** We make the WING PIANO and sell it ourselves. It goes direct from our factory to your home. We do not employ any agents or salesmen. When you buy the WING PIANO you pay the actual cost of construction and our small wholesale profit. This profit is small because we sell thousands of pianos yearly. Most retail stores sell no more than twelve to twenty pianos yearly, and must charge from \$100 to \$200 profit on each. They can't help it.

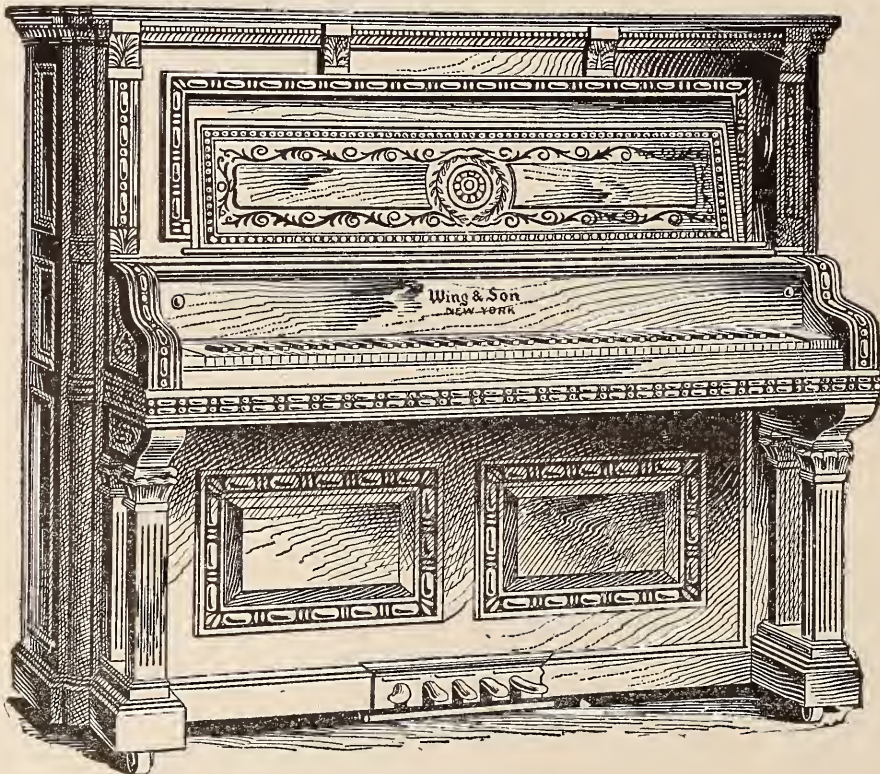

*A Wing style—45 other styles to select from.*

**SENT ON TRIAL** WE PAY FREIGHT. NO MONEY IN ADVANCE. We will send any WING PIANO to any part of the United States on trial. We pay freight in advance and do not ask for any advance payment or deposit. If the piano is not satisfactory after twenty days' trial in your home, we take it back entirely at our expense. You pay us nothing unless you keep the piano. There is absolutely no risk or expense to you.

Old instruments taken in exchange.

**EASY MONTHLY PAYMENTS.**

**INSTRUMENTAL ATTACHMENT** A special feature of the Wing Piano; it imitates perfectly the tones of the mandolin, guitar, harp, zither and banjo.

**IN 34 YEARS 33,000 PIANOS** We refer to over 33,000 satisfied purchasers in every part of the United States. WING PIANOS are guaranteed for twelve years against any defect in tone, action, workmanship or material.

**WING ORGANS** Are just as carefully made as Wing Pianos. They have a sweet, powerful, lasting tone, easy action, very handsome appearance, need no tuning. Wing Organs are sold direct from the factory, sent on trial; are sold on easy monthly payments. For catalogue and prices write to

**WING & SON,** 226 and 228 East 12th St.,  
NEW YORK.

1868—35th Year—1903.

# SERGEANTS' CONDITION PILLS

**POLK MILLER DRUG CO.**

IS SYNONYMOUS WITH

**DOG REMEDIES.**

**SERGEANT'S CONDITION PILLS** have to do especially with the health of a dog.

Every dog should be in a healthful state—just as much so as a person. You can't expect a dog to work right in the field, stud or bench show if he is ailing. He is bound to ail; just as much as human beings, and they you know, are always ailing—either through neglect, change, confinement, accident or over-work.

You will find a dog bothered just as much as a person when it comes to sickness.

**SERGEANT'S CONDITION PILLS** do for a dog what thousands of good remedies do for a man—they cure.

They will cure the dog of Indigestion, Nervousness, General Debility, Sleeplessness, Fretfulness, Meanness, Chills, Fever, Ague, Mange, Distemper, Chronic Dyspepsia, Anaemia, Catarrh, Short Sightedness, and Loss of Scent.

**SERGEANT'S CONDITION PILLS** build a dog up.

They put life into a dog, eradicate all weariness, physic and strengthen him.

The only difference in this medicine for dogs and that made for man is, that it is made of a formula stronger in its ingredients, for, when it comes to medicine a dog can stand more than man.

**SERGEANT'S CONDITION PILLS** cost 50c. and \$1.00 per box at Druggists or by mail (prepaid) from

**POLK MILLER DRUG CO.,**

**RICHMOND, VIRGINIA, BOX 217.**

There isn't anywhere a dog lover or owner who wouldn't like to have our 48 page Treatise on Dogs. We will send it and a Pedigree Blank to any address for 3 cents in stamps, which go to pay the postage.



# Far-famed Miami Valley

Government statistics prove that the Miami Valley in Ohio produces better grain and has purer water than any other section of this country. It is Nature's garden. Right in the heart of this favored spot is our distillery. We have at our very door the two essentials for producing the finest whiskey in the world--the best grain and the purest water. Add to these one of the most completely equipped distilleries ever operated and an experience of 37 years in distilling whiskey and you have a combination that is unequalled anywhere. That's why **HAYNER WHISKEY** is the best for medicinal and other uses. That's why we have nearly half a million satisfied customers. That's why **YOU** should try it. Don't forget that it goes direct from our own distillery to you, with all its original strength, richness and flavor, carries a **UNITED STATES REGISTERED DISTILLER'S GUARANTEE** of **PURITY** and **AGE** and saves the dealers' enormous profits. Your money back if you're not satisfied.

# HAYNER WHISKEY

**4 FULL QUARTS \$3.20**  
**EXPRESS CHARGES PAID BY US.**

**OUR OFFER.** We will send you **FOUR FULL QUART BOTTLES** of **HAYNER'S SEVEN-YEAR-OLD RYE** for **\$3.20**, and we will pay the express charges. Try it and if you don't find it all right and as good as you ever used or can buy from anybody else at any price, then send it back at our expense and your \$3.20 will be returned to you by next mail. Just think that offer over. How could it be fairer? If you are not perfectly satisfied you are not out a cent. Better let us send you a trial order. If you don't want four quarts yourself, get a friend to join you. We ship in a plain sealed case, no marks to show what's inside. **Write our nearest office NOW.**

Orders for Arizona, California, Colorado, Idaho, Montana, Nevada, New Mexico, Oregon, Utah, Washington or Wyoming must be on the basis of 4 Quarts for \$4.00 by **EXPRESS PREPAID** or 20 Quarts for \$16.00 by **FREIGHT PREPAID.**

ESTABLISHED  
1866.

**THE HAYNER DISTILLING COMPANY,**

**DISTILLERY,  
TROY, OHIO.**

DAYTON, OHIO.

ST. LOUIS, MO.

ST. PAUL, MINN.

ATLANTA, GA.







THE BULLS STOOD STILL AND GAVE ME A CHANCE FOR ANOTHER SHOT.

# RECREATION

Volume XIX.

AUGUST, 1903.

Number 2.

G. O. SHIELDS, (COQUINA) Editor and Manager

## HUNTING BLUE BULLS IN INDIA.

W. H. FEE.

One Sunday evening in February, when the Ahmedabad mail train pulled out of the Bombay terminus, behind a good American locomotive, I was one of the passengers. My destination was Godhra, and visions of deer, the woods and the fields were rising before my eyes. Godhra is an Indian town of about 20,000 inhabitants, 350 miles North of Bombay, and 90 or 100 miles Southeast of Ahmedabad. The next morning, after having changed cars at Anand Junction, I reached Godhra at 10 o'clock. Mr. Robert Ward met me at the station. He was to be my host and had promised me some good shooting.

The following morning we packed such things as we should need for 4 or 5 days and took the train for Nadiad, where we were to start out on camels and try our luck on the nilghai. The nilghai, or nilghau, *Portax tragocamelus*, is one of the largest of antelopes, having much the character of an ox, the horns, head and muzzle of an antelope, the flat, compressed neck of a horse, a thin, erect mane, and a singular, beardlike tuft of stiff hair growing out of the middle of its throat. Its forelegs are somewhat longer than the hindlegs, and its withers rise so much as to give it the appearance of having a hump. The color of the females, and of the males until full grown, is a light brown. The bucks, after attaining their full growth, turn to a deep, slatey blue, which gives them their name, the Persian nilghai meaning blue bull.

We were up not much later than old

Sol the next day. After a hasty breakfast, we mounted the camels, Mr. Ward and I on one, and 4 men on 2 others. When we had followed the main road 10 miles, we branched off and traveled a mile or so through the fields. The average Indian field is about an acre in area and is surrounded by cactus hedges. When there was an opening the camel was steered toward it, but when there was an entrance but no exit, the hedge had to be cut by a man with a bill hook, which is a curved knife 15 or 16 inches long, fastened in the end of a short bamboo pole. Once, when we were waiting near a 3-foot fence for a man to come and cut it, Ward drove the camel close to the hedge, and with a kick and a nudge with a stick he made the beast jump over. As I was not aware of the accomplishments of his camel, I came near rolling off backward when the huge beast raised his forelegs, and when he put them down on the other side I did my best to go over Ward Sahib's head.

We had had news as to the whereabouts of a herd of nilghai, and it was not long before a man came up to tell us there were 4 bulls in a field half a mile distant. The camel was made to jee, or kneel, and taking our rifles, Ward a .45 and I a .303, we went after the blue bulls. With the assistance of friendly hedges, we were able to get within 100 yards of the wary animals.

Bang! A miss! and a punch in the ribs from my friend. The bulls, not being able to see anything, as we were well shielded by a big hedge, and the

powder was smokeless, stood still and gave me a chance for another shot, which did not follow the bad example of the first, but hit my quarry in the shoulder. Then, of course, the others made off, leaving the wounded bull in the next field, bleeding at the mouth. Another shot finished him, when his throat was cut. He was a beauty, weighing at least 400 pounds. He was left to the care of some of our men, who cut him up and packed him on another camel.

Then we started after the remainder of the herd. They had gone a mile before stopping and we had more difficulty in getting up to them than we had the first time. As we were just getting in a good shooting position, off they went half a mile farther. At last we got close enough for me to fire again. The bull shook, and I was almost certain I had him; but he pulled himself together and started off like a streak. Soon he left the other 2, so we followed him. Although he was badly hit he still was equal to any hedge he met, clearing it neatly. As Mr. Ward was a resident of the country, he generally let me have first shot, and a calling down if I missed. We each hit the wounded bull once more, and then lost track of him.

It was midday and we were hot and thirsty, so we stopped under a tree and had a lunch. Then the camels came up, together with our men, and some other natives, who had been our informants. As we sat there under the tree, the natives in that vicinity who had heard the shots, and who only get a chance to see a sahib about once a year, came up and sat down to watch us. Just before leaving I counted 75 of the curious people, sitting round us in a circle, on their haunches.

One would suppose that with the population of India there would be little game. However, the Hindoos are forbidden by their religion to kill any animal. Often when they find a scorpion in their houses they will

carefully pick it up with a stick and carry it into the fields. Naturally they are vegetarians, except some of the lower castes, who eat anything. In consequence of the doctrines of their religion, there are some who do not like to see the sahibs kill the nilghai; but others, whose crops have been damaged by the animals, are willing they should be killed, and will help to do it, by giving information, etc.

After we had finished our lunch, and were thinking what was best to be done next, a man came in with news of the bull we had wounded. However, when we arrived where he had been seen, we found that some rascally natives, of the anti-kill variety, had chased him away. Reluctantly we abandoned the chase, feeling sorry to leave him to his fate so badly wounded.

Mounting the camels, we struck off toward a neighboring village, where orders had been left for something to eat. At this village we had curried chicken and rice, to eat with our fingers, native fashion. We got these eatables from some natives who had been converted by the missionaries, and who seemed to be in better circumstances and more intelligent than the average villager. After resting, we rode 10 miles back to Nadiad, where we arrived after dark; hungry, tired, but happy.

The camel is a fearful beast to ride; a continual jolt, jolt, jolt. The saddle is made for 2, tandem fashion, with the hump in the middle. The camel is a pacer, and his steady jog for a dozen miles causes the rider to be aware that he has a pair of shoulders and a back.

The next day a hind quarter of the blue bull was forwarded to Bombay, and we went on to Umreth, a town between Anand Junction and Godhra. There we spent 2 days, and Mr. Ward's turn came. He brought down a fine young buck, full grown but not yet turned dark in color. The buck



looked like a large female with horns. Our experiences at Umreth were similar to those near Nadiad. The country was more open, and the weather grew hotter. We rode the camels till we either got news of the nilghai or happened to see them. If the latter, we dismounted and sent the camel on with a man. The nilghai would watch the camel and thus enable us to stalk better.

As the native never kills the blue bull, the animals get used to him and

are not frightened at his approach. The hunter must be careful where he shoots, as he is likely to kill a native, thereby getting himself in trouble, which may cost him many rupees.

From Umreth we returned to Godhra, where I spent the rest of my time among the waterfowl on Godhra lake, an artificial body of water, constructed by native labor during the recent famine of 1900. I then returned to Bombay, tanned like a native, having been in the jungle 2 weeks.

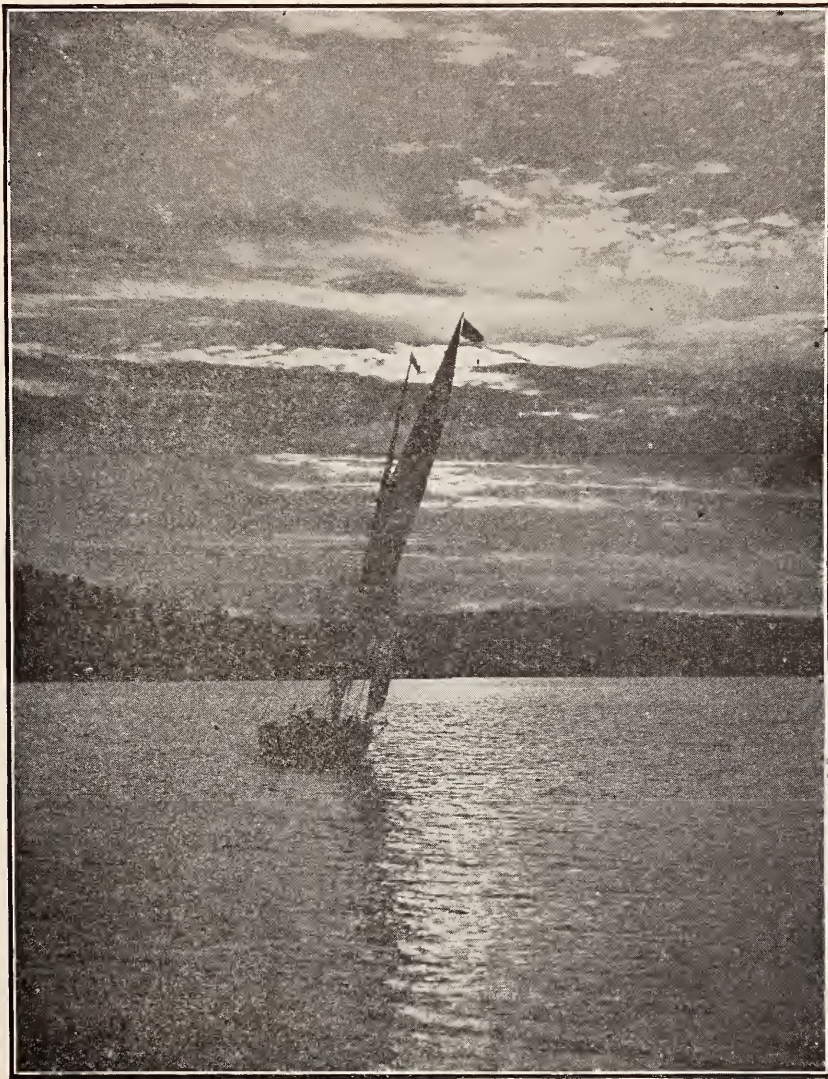

AMATEUR PHOTO BY T. J. CURRIE

A MOONLIGHT SAIL.

Highly Commended in RECREATION'S 7th Annual Photo Competition.



NEST OF RUFFED GROUSE.

One of the 17th Prize Winners in RECREATION'S 7th Annual Photo Competition.



A SUN BATH.

One of the 17th Prize Winners in RECREATION'S 7th Annual Photo Competition.



A DUET.

One of the 17th Prize Winners in RECREATION'S 7th Annual Photo Competition.

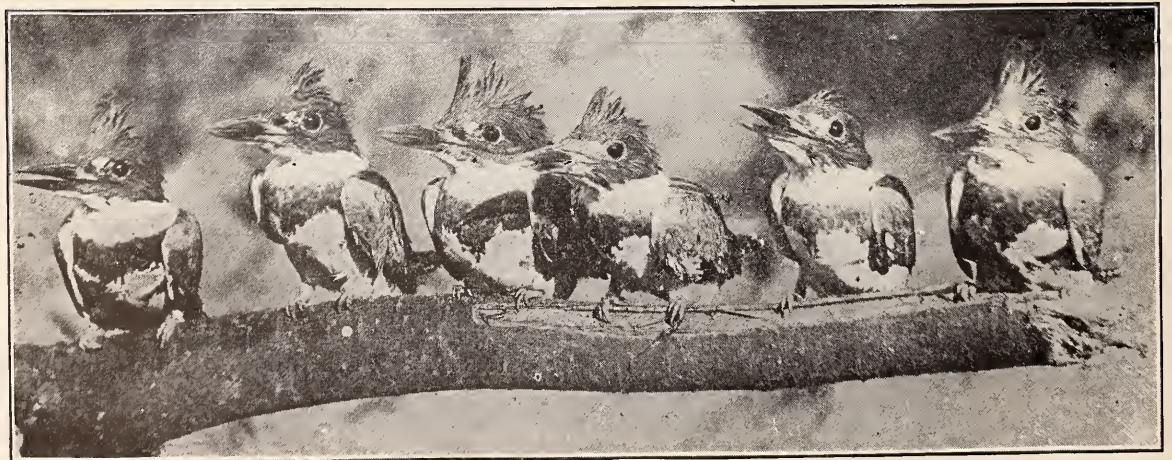

RIGHT DRESS

AMATEUR PHOTOS BY JAMES H. MILLER.

One of the 17th Prize Winners in RECREATION'S 7th Annual Photo Competition.

## LOON NOTES AND QUERIES.

ROBERT J. SIM.

Illustrated by the Author.

Birds of the order *Pygopodes*, have long had a great fascination for me. The diving birds which have been found in this country, to my certain knowledge, are the great Northern diver, or common loon, the red-throat loon, the horned grebe, and the piedbill grebe. During the autumn migra-

ponds, where it sometimes associates with a coot or 2.

In November, 1901, during a short stay at the lake, I spent many hours watching a horned and a piedbill grebe. They were feeding together on a sluggish stream which comes "from the haunts of the coot

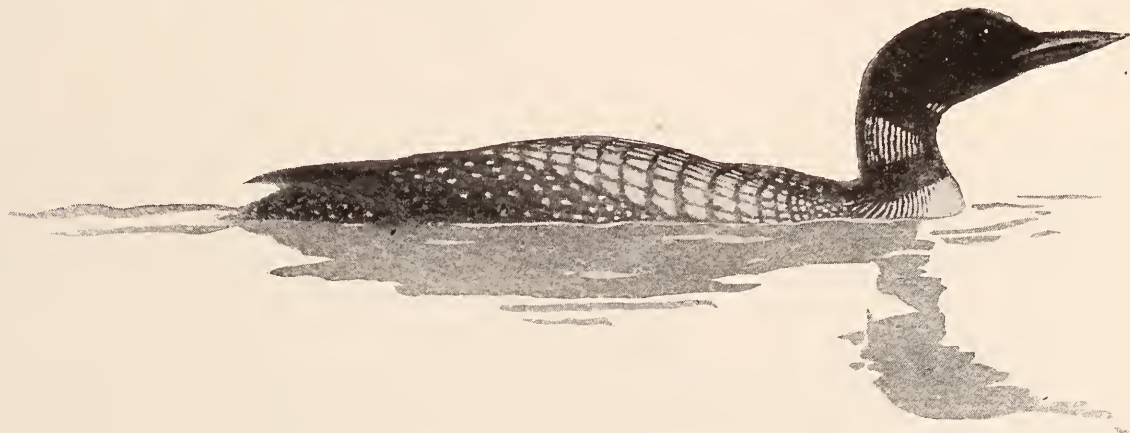

GREAT NORTHERN DIVER.

tion the horned grebe, in sober dress, is common on lake Erie, but is seldom seen inland. On the other hand, the little dabchick is more often met on streams and

and the heron." The piedbill made many successful trips to the lower regions, and seemed always to come to the surface to swallow his food. Minnows were swal-

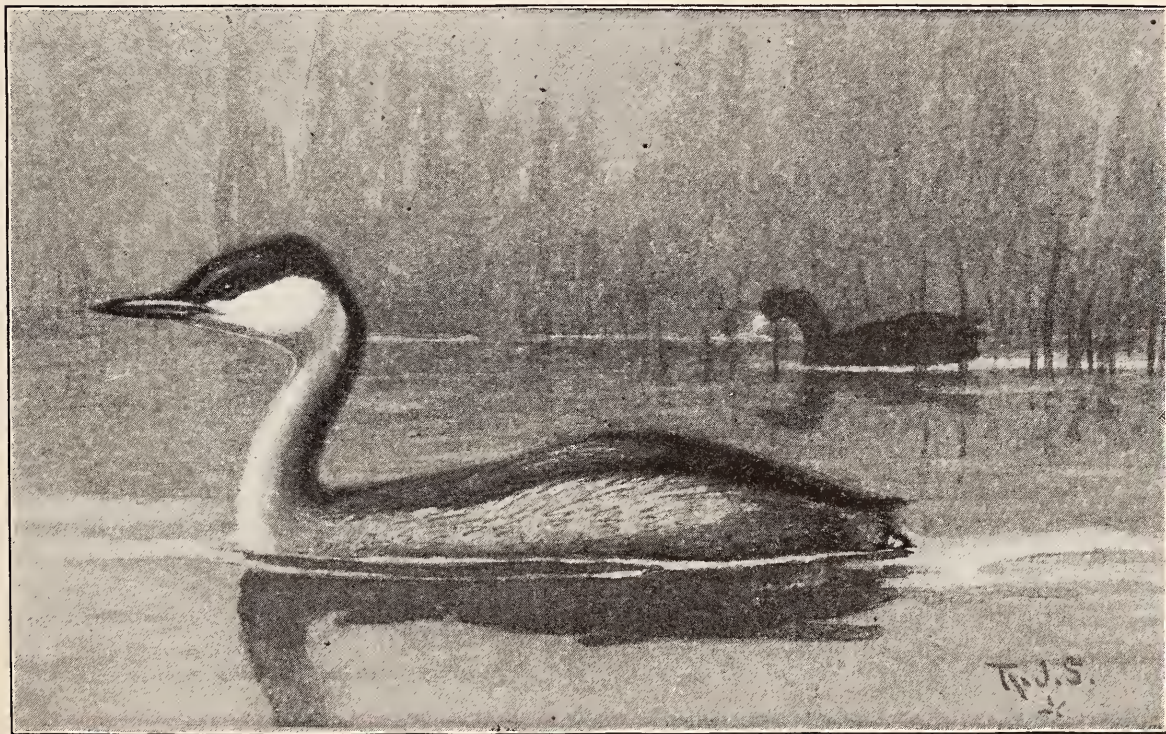

HORNED GREBE IN WINTER PLUMAGE.

lowed head first; crayfish were always shaken and dabbled in the water before being gulped down. The other grebe was never seen to bring food to the surface. Can it be that he was unsuccessful? Or did he swallow his food while submerged? I should like to know the opinion of observers who have studied these birds more than I have.

It has been said that a loon always alights on the water with a great splash. Not long ago I saw 2 loons settling toward the surface of a Michigan lake. They sailed some distance, then struck the water, one after the other. The first came down on its breast and slid along, making a sheet of water spread into the air at each side.

body was held in a more or less upright position during only 2 operations. First, it occasionally stood up and rapidly fanned its wings as any swimming bird does, at times. Second, sometimes it simultaneously ran and flew across the floor, carrying the body almost upright, after which it dropped suddenly to its breast.

I have heard the great Northern diver give 3 distinct cries. One consisted of 3 long notes, each succeeding one higher and less loud, all done in clear soprano. Another cry reminded me of the squeaking of a wheelbarrow. The third was the most famous loon note, somewhat resembling a laugh. To me, it suggested the screech owl's wail, though much louder. Accord-

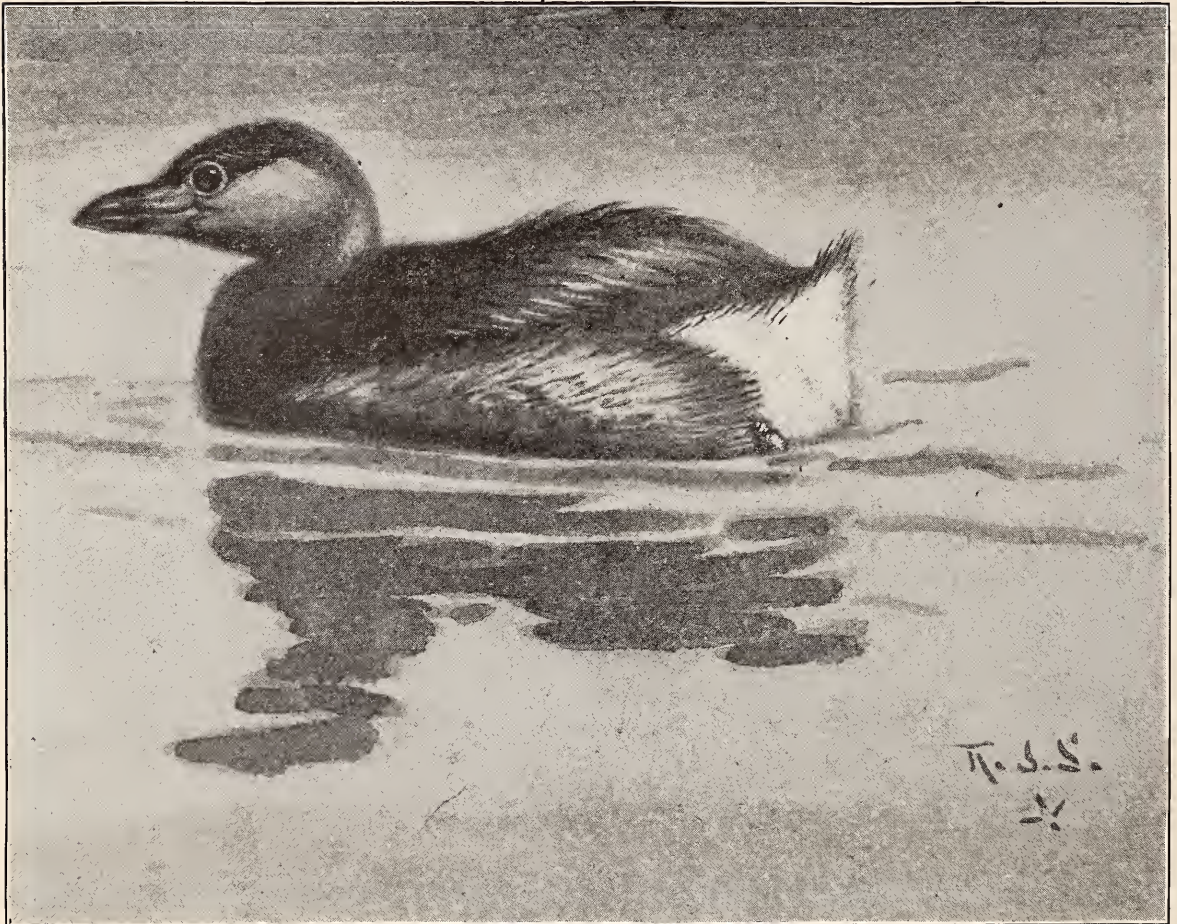

PIEDBILL GREBE.

The other dropped quietly, tail first, as gently as a mallard could have done.

All the loons that my companions and I observed last spring seemed to swim with their tails drooping, submerged, as shown in the accompanying sketch. Is this the more common way?

Who has seen a grebe or a loon stand erect as they do in books? How did the bird look when he did so? My experience is limited to one captive piedbill grebe. Its

ing to our observations the loons seemed to be much disturbed in unsettled weather, and just before a storm they would fly over, crying repeatedly. This habit is denied them by some naturalists. The calls of these birds seem less weird than the song of Bartram's sandpiper, and less mysterious than that of the screech owl. However this may be, the cries of the great Northern diver excite feelings in me that no other bird notes do.

## THE GIANT BROWN BEARS OF ALASKA.

J. A. LORING.

Probably no other group of animals can so thoroughly adapt themselves to the climate and food conditions of the country in which they live, as the bears of North



COPYRIGHT, 1908, BY THE NEW YORK ZOOLOGICAL SOCIETY.

A TYPICAL KADIAK.

Male. Three years old. Weight about 800 pounds.

America. While they are provided with the teeth and organism of carnivorous animals, nature has also endowed them with a system and an appetite which soon acclimatizes them to any part of the continent,

from the ice floes of the North to the everglades of the South. It matters not whether they have been accustomed to pineapples and turtle eggs in Florida; wild honey and acorns in Pennsylvania; insects, roots, berries and offal in the Rocky mountains; salmon and grass in Alaska, or seal meat in the Arctic; in captivity they accept an artificial diet as variable. I have even known a bear to eat a greasy dish rag that once did duty about camp; and who has not heard miners in the West tell of the amusement they have had getting poor Bruin drunk.

The Northland affords bears the opportunity to show the carnivorous habits for which they seem best adapted, while in reality they are omniverous. Were it not for the seals and unlimited supply of fish, the bears living along the coast would be obliged to adopt more of a vegetarian diet, as do their kin inhabiting localities where salmon are not found.

In Southern countries where vegetation and animal life are always awake and bears are able to secure food throughout the year, they do not hibernate. In the North their lives are necessarily divided into 2 seasons; a season of activity, and a season of sleep or hibernation.

The largest of living carnivorous animals, the giant of all bears, is the Kadiak bear of Alaska. For some unaccountable reason the largest specimens are found on the islands of Kadiak and Afognak, at the mouth of Cook inlet. So few Kadiak bears have been killed by white hunters, that at present there is no authentic record of the weight of a large representative of this huge species, although stories are current of individuals supposed to weigh 2,200 to 2,700 pounds. It is safe to say, however, a Kadiak bear that would tip the scales at 1,500 pounds would be close to the limit. It is impossible to obtain a correct idea of the size of the animal when alive by measuring dried skins, for during the process of curing, the natives lace the hides to frames, or stake them to the ground, thereby stretching the skins out of proportion. The largest skin in possession of the Alaska Commercial Company at Kadiak, in July, 1901, measured  $9\frac{1}{2}$  feet from nose to tail and  $10\frac{1}{2}$  feet across the outstretched front paws.

Formerly these bears were abundant on the island from which they take their name, but at present it is doubtful if the yearly number killed by both native and white hunters will average 35. In fact, their num-

ber has been so reduced that the hunter who succeeds in adding 2 skins to his collection in a season considers himself fortunate.

Including the Kadiak bear, there are 5 distinct species of fish-eating bears in the Alaskan brown bear group, all of them giants of the *Ursidae* family. As far as known they inhabit the timbered islands and coast region of Western Alaska. These bears are closely allied to the European brown bear, which relationship is used by scientists as evidence that the Alaska peninsula and Siberia were once connected.

The Alaskan bears vary greatly in color from a pale brown, almost yellow in some cases, to olive brown in others. In the fall, after the hair has attained its full growth, they are much darker than when first emerging from the den in the spring.

The change from hibernation to a state of activity is governed by the season and locality in which they den up. Along the coast, where the salt air melts the snow and hastens spring, they come out earlier than do the bears living in the interior.

The natives believe that the females give birth every second or third year. The young, which are brought forth the last of January or first of February, weigh but a few ounces and are the smallest animals born to parents of such huge size. The number of cubs in a litter is one or 2, rarely 3. They remain in or near the den until the last of April, at which time they are large and strong enough to accompany their mother on foraging expeditions. They are exceedingly playful and, while the old bear is busy hunting food, linger behind to wrestle or box with each other. The whereabouts of the family is sometimes disclosed by the bawling of the cubs when cuffed by their mother for misdemeanors. At the age of 5 months, were it not for the white collar that frequently encircles the neck, they would be difficult to distinguish from young grizzlies. The white throat mark usually disappears during the second or third year, although I have seen skins from animals 4 years old which had white on the chest, and in rare instances a spot is found on the shoulders. Throughout the first year the cubs remain with their mother, and sometimes hibernate with her, but the following spring they abandon her to begin an independent life.

On emerging from the den, about the first of April, the food of the adult brown bears consists almost entirely of grass, roots and leaves, but as the snow disappears from the mountains, they are able to secure berries that were preserved by the early snows of the previous year. Up to the beginning of July, they spend much time on the grassy slopes at and above timber line, and it is not uncommon to find them stretched at

full length on a boulder or bank of snow, sunning themselves.

Everything a bear examines he seeks with a view to appease his appetite. Watch one through a pair of field glasses. With head held low, he saunters slowly along, sniffing as he goes. Suddenly he stops and with his paw turns over a stone, pulls to pieces a stump, or digs up a clod of earth in hope of securing a mouse, grub, or bit of tender root that his keen nose has detected. He works carefully along, zigzagging his way here and there, until, when he is ready to return to the timber to take his mid-day siesta, the scene of his exploration bears the appearance of having been uprooted by hogs. Investigation would probably reveal tracks of various ages, where he had previously been, which is proof that this is his favorite feeding ground. The experienced hunter then knows that if he remains in the locality and watches, it will be but a few hours until he will secure a shot.

Once in the timber, Bruin selects a level spot under a tree, or digs a hollow in the cool, damp earth, and after rolling in it, curls up and goes to sleep. He is also fond of taking sunbaths while he sleeps. The attitudes a sleeping bear assumes are many and ridiculous, but his favorite one is lying on his side. I have seen them resting on their back, all fours in the air and head turned to one side. When sound asleep they are hard to awaken. On several occasions after shouting and vigorously punching bears under my charge, I have been about to give them up for dead, when they slowly came to their senses and rolled over.

About 5 o'clock Bruin awakens and again starts out to satisfy the inner bear. He stays away all night, for as he hunts his food more from scent than sight, he leads a nocturnal as well as a diurnal life. Such is the daily life of a brown bear up to the middle of July. The salmon then begin to run up the streams to spawn, and brown bears seek the valleys to feed on them. From then until the middle of September the food of bears consists principally of fish and berries. This is the season when bears lay on fat to carry them through the long cold months, and they take advantage of every opportunity to glut themselves.

Along salmon streams and thickets where berries are abundant, bears wear deep wide trails in the moss. At the mouth of streams where the water is shallow, affording them excellent opportunity to catch fish, the grass is so trampled one would think a herd of cattle had been pastured there. At this season the danger of being attacked by bears is increased, for the trails leading to and from the mountains

in all directions, afford easy travel to the weary prospector with his heavy pack, and the thick carpet of moss deadens his footsteps. On rounding a sharp turn, he comes face to face with a much surprised bear. The animal thinks himself the victim of a skin game, and naturally shows fight. If the prospector is unarmed, it is likely to go hard with him. Sometimes he wins the day by hammering on his gold-pan and shouting lustily, but other poor fellows are less fortunate. Had the same bear detected danger, the prospector on reaching the stream, would have found only roily water and a fresh trail leading through the grass where the bear had made good his escape.

Secrete yourself near a salmon stream and watch. The creek is about a foot deep, and hundreds of salmon fight their way

again and looks about. Convinced of safety he saunters to the edge of the stream and peers into the water. He hesitates but a few seconds, for as the salmon swim past, with a quick stroke of his paw, he gracefully flips one on the bank and seizes it between his teeth. Carrying the fish a few feet from the water's edge, he holds it on the ground with his paws while he eats it entire, or if it is during the height of the salmon run and he is able to secure all the fish he wants, he will take only the head or tear out the belly. I have seen scores of salmon in all stages of decay lying on the bank, with only the parts mentioned missing. The bear does not hesitate to eat fish that have been dead several days, even when possible to catch live ones.

Bruin is equally at home in a berry patch,



COPYRIGHT, 1903, BY THE NEW YORK ZOOLOGICAL SOCIETY.

A GROUP OF COUSINS IN THE PARK.

Cinnamon.

Kadiak.

Kadiak.

Silvertip Grizzly.

against the swift current, some even being driven on the bank by their quarrelsome companions. If you are on the lee side of the stream from that on which your game is expected, you will be treated to a spectacle well worth your time and trouble; but if you have not taken that precaution, an approaching bear will surely scent danger and you will miss the drama about to be described.

From behind the screen of drooping boughs keep close watch of the flat before you. Late in the afternoon a bear appears at the edge of the timber. He rises on his haunches, and with paws dropped by his side, carefully surveys the flat before coming into the open. Then he falls to his feet, and walks slowly toward the stream; but before reaching it he rises

for he has a delicate tooth for sweets and berries. Here you occasionally catch a glimpse of a bear with his head and shoulders above the brush, as he rises and gathers in the branches with his paws, then strips off the fruit and leaves between his teeth. Sometimes he is more particular, and while holding the branches is careful to pick only the fruit.

In captivity bears are slow, clumsy, and awkward, but in their natural haunts their actions are graceful, and when occasion demands, remarkably quick. Other than a low guttural noise, they make no sound unless wounded or enraged. Then they bawl, not unlike frightened cattle. The brown bears are fond of water and can swim and dive almost as well as polar bears.

Probably the meanest trick of which a bear is guilty, is that of breaking into *caches* of miners and trappers, and making havoc of their supplies. Sacks of flour are ripped open, blankets and tents torn to shreds, and cooking utensils and canned goods hammered to atoms. Then the unfortunate owner is compelled to live on short rations during the remainder of his stay in the mountains.

Up to the first of June bear skins are prime, but after that date the hair begins to shed and they are then worthless, although individuals in good pelage are sometimes killed as late as July 10. By the middle of September they are covered with a layer of fat, often 4 or 5 inches thick on the rump and shoulders, and their coat has then attained its full growth. About 2 weeks later, the time being governed somewhat by season and locality, they have selected a suitable den in which to hibernate. This is usually a cave in the rocks, or hollow under the roots of an upturned tree. As the season advances they do not wander far, and with the first severe weather take to the den for the winter, although should there be a warm spell they may come out a short time. Again, if water chances to drip into the den, they will hunt more favorable quarters. A bedding of leaves and dried grass is usually found in a den with bears having cubs.

The Indians sometimes hunt them with dogs during the winter. They locate a den and after breaking into it, shoot or spear the occupants. Although the animals are supposed to be in a state of torpidity, they are lively enough to put up a strong objection. In fact they move about in the den so much during the winter that the majority of skins from adult animals are more or less damaged by being chafed on protuberances in the den.

While hunting singly, unless accompanied by dogs, most Alaskan Indians are loth to attack full grown brown bears, particularly if they have cubs, and should a bear visit a native's *cache* during his absence, he superstitiously considers it a bad omen.

That bears often battle with each other is proven by the number of skins brought to the traders, which have missing claws and large gashes about their bodies. Such scars are sometimes marked by a twisted growth of hair, while on others it refuses to grow at all.

These animals are extremely difficult to stalk, for at the first intimation of danger they usually light out at once, and will not return to the same locality for weeks. Sometimes they cross a range of mountains and seek new feeding grounds. Their keen hearing and acute sense of smell render it absolutely necessary for the hunter to

approach from the leeward. A person may travel months in a country where bears are common, he may see fresh tracks in abundance, some made but a few minutes before, but he may seldom see a bear. Their eyesight is poor. I have been within plain view of 2 brown bears not more than 100 feet distant for half an hour and they failed to detect me. If unable to see the hunter, when fired at they are as apt to run forward as away from him, and since the use of smokeless powder this danger is increased.

Their wrath is quick and spasmodic. Cubs in captivity when enraged will rush on a person, seize his trousers' leg between their teeth and give it several vigorous shakes, then go prowling about as unconcerned as though nothing had happened. Just so with the old ones, only more so. I know of several cases where bears, when surprised at close range, have attacked persons, and after knocking them down and biting them, have deliberately walked away. When enraged, instead of squeezing their victim as is generally supposed, they rush on him, and when within a short distance rise on their hind feet and strike him down with a blow from their powerful paw. One blow well aimed is sufficient to break a man's neck, or tear away the side of his face. In addition to this they may bite him a few times as he lies prostrate on the ground. While this is their usual mode of attack, there are exceptions.

There is not much doubt that in many cases a cool headed person with nerve could stop the charge of an infuriated bear. During the summer of 1901, 2 Eastern hunters were after brown bear in the vicinity of Chitina bay, Cook inlet. One afternoon they saw a bear feeding on a mountainside near camp. A native and one of the hunters stalked the animal and wounded it. In his anxiety to secure the specimen, the sportsman ventured close and fired his last cartridge, but unnerved by running, his bullet went wild of the mark and the infuriated beast charged. The native shouted to him not to run, but the words were misunderstood, and he naturally took to his heels, closely pursued. The native, however, stood his ground until the animal was dangerously near, then gesticulating wildly, he jumped into the air and let out a series of yells that would have stunned the nerves of the evil one himself. The surprised bear advanced but a few feet farther, then turned and fled. The native explained that he had stopped charging bears in that manner before, and argued that his shouts and actions distracted the bear's mind and turned his fury to fear. Such nerve is seldom found, either in white men or Indians.



## TARPON FISHING AT PASS CHRISTIAN.

M. SNOWDEN.

A few tarpon having been caught late in July and the first week in August, Dr. A. R. Robertson, Mr. J. E. Hanson, Elmer Northrop, Oscar Wilson, and Captain J.

paradise. Being from the hill country and no angler, I went along as witness and timekeeper; and incidentally to catch small fry for skillet purposes.



LIVE OAKS IN PASS CHRISTIAN.

AMATEUR PHOTO BY S. L. TAYLOR.

McDonald, of the Queen of the Fleet, became possessed with the laudable ambition to make the record catch of tarpon in Mississippi waters and to make Pass Christian rival the Florida resorts as an anglers'

By much use of the telephone Dr. Robertson aroused the whole party, and the entire neighborhood also, in the small hours of the morning; and by 4 o'clock we were all aboard the Queen of the Fleet,

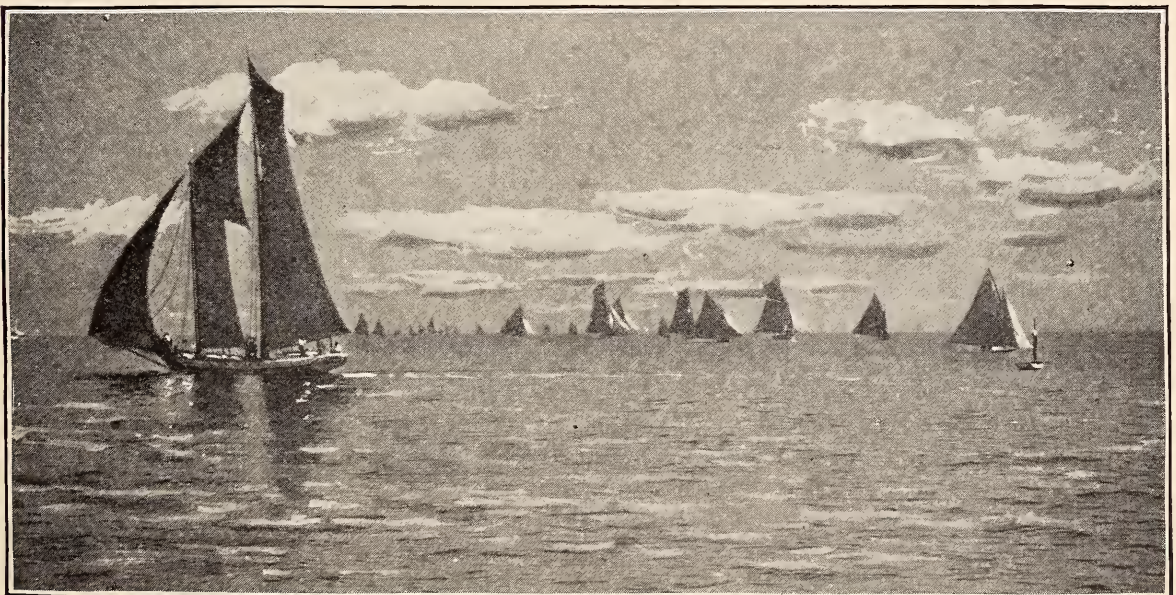

QUEEN OF THE FLEET IN THE LEAD, PASS CHRISTIAN REGATTA.

AMATEUR PHOTO BY S. L. TAYLOR.

the fastest and best schooner on the Gulf coast, Mississippi. Captain McDonald, of the *Queen*, makes a specialty of taking out parties for all kinds of fishing; and besides being expert with the rod and reel, he is a clever fellow and a good captain.

We were somewhat delayed at the ice factory in getting our ice supply; but the time was well improved in catching sardine and mullet bait. At 6.10 a. m. we were off for Tarpon Keys, 6 miles South of the Pass; and after a delightful sail of 50 minutes, we reached the Keys at 7 o'clock sharp. During the run out, rods and reels were carefully fixed and breakfast was eaten. By 7.10 all hands and the cook were in skiffs, fishing in couples. Dr. Robertson and Captain McDonald soon had strikes, as the water seemed alive with tarpon. The sea was as smooth as glass and the striking of the tarpon, either at bait or food in the water, was a beautiful sight. The glint of the silver scales on the quiet water and in the morning sun made a dazzling picture. Soon the welcome cry of "keep time" was heard, for Dr. Robertson, after having had several strikes, hooked his fish and the fight was on.

The tarpon made his usual wonderful leaps, high in the air, to shake the hook from his jaws; but the Doctor was his master and in 7 minutes landed his first tarpon. The crowd cheered the Doctor, that being the first tarpon caught by a Pass Christian sportsman; and his success stimulated the others to greater exertions.

Captain McDonald hooked a beauty; but being a little over anxious, he put too much pressure on his line and Mr. Tarpon continued his course for Havana.

Soon the Captain redeemed himself by landing a regular "papa" in 16 minutes. Dr. Robertson completed his score by landing a larger one than the Captain's, in 11 minutes.



TARPON CAUGHT AT  
PASS CHRISTIAN  
AUG. 14, 1902

Then Oscar Wilson worked one up in 10 inches of water on the bank of one of the Keys, but in its frantic efforts to escape its pursuers the tarpon beat the hook against the shells and was gone. Wilson did not say much, but what he looked was sufficient to make a book.

Before long Hanson landed the grandpa of the bunch, in 14 minutes; and he was a beauty. Hanson claims that by "expert knowledge" he landed the first tarpon he ever hooked.

Captain McDonald finished the catch with a small one. The fishing was over by 1 p. m.; and after a good luncheon the *Queen* was headed for home so photographs could be taken. The 3 large tarpons measured 5 feet 6 inches and the 2 smaller ones 4 feet 7 inches each.

Pass Christian offers unlimited sport to all lovers of the rod and reel; and the anglers of the Pass extend a cordial welcome to all the brethren.

## A TRAGEDY.

A. L. VERMILYA.

On a leafy bough of a maple tree  
That stands in a city street,  
Is a robin's nest—a masterpiece  
Of the builder's art complete.  
Once above the nest a robin sang  
To her downy, cherished brood,  
Or flitted lightly about the lawn,  
In quest of their daily food.

But one sad morn when the mother stopped  
To drink by a little stream,  
A boy with an air gun came that way—  
Then closed her summer dream.  
She lay with the blood stains on her breast,  
Close by the streamlet's brink,  
While the cruel boy with his gun sped on—  
He did not care nor think.

All day the nestlings cried for food,  
All day the sun beat down  
On the nest in the maple tree that stood  
In the heart of the busy town.  
All night the moon looked sadly on,  
As her light she softly shed  
On the orphan birds in the lonely nest—  
Ere morn they all were dead.

The straw built nest is empty now,  
And through the maple tree  
The summer winds, as they come and go,  
Sing ever mournfully.  
O parents, teach your thoughtless boys,  
With earnest, heartfelt words,  
To walk in nature's pleasant ways,  
And love the singing birds.

## AN INTERESTING SUMMER BOARDER.

J. H. FISHER, JR.

I hand you herewith a photo of a pet fox and his summer camp. He was the star boarder at one of the resorts at Millinockett, Me., last summer. One of the guides captured him in the woods when he was a kitten, took him home, raised him

tently for a time and try to estimate its size, it may grow under your imagination to be 10 feet wide and 6 to 8 feet high. As a matter of fact, however, the house is built of small birch sticks; is about 18 inches wide, 24 inches long, 20 inches high



WHAT MONSTER IS THIS?

AMATEUR PHOTO BY J. H. FISHER, JR.

on a bottle, and he soon grew to the full stature of his kind. He was as tame and as sociable as any dog. He would romp and play with the children, or with the dogs, or with the grown people, as freely and as joyfully as any animal I ever saw. He readily acquired the omnivorous appetite of the dogs about camp and would eat anything and everything that came from the table.

The picture presents a strange optical illusion. Almost anyone looking at the cabin would say it was 4 to 6 feet square and of equal height. If you look at it in-

at the eaves and 26 inches at the cone. It is covered with miniature cedar splits or shakes. The balcony in front is about 12 inches wide.

Strangely enough, the proprietor of the resort, when he closed his place for the winter, left Reynard to hustle for himself; so the animal is probably living on grouse, snow buntings, mice and any other small birds or quadrupeds he may be able to capture. I shall be curious to know whether he comes back to the hotel when it opens at the beginning of the fishing season.

"So he gave you a dog?"

"Yassir," answered Erastus Pinkley.

"He must like you."

"Well, I can't make out foh sho' whether he likes me or whether he don't like de dog."—Popular Mechanics.



BARROW'S GOLDEN-EYE. ADULT MALE, *CLANGULA ISLANDICA*.



WHITE PTARMIGAN, WILLOW PTARMIGAN, ETC. *LAGOPUS LAGOPUS*.  
Summer Plumage.

## IN THE WOODS WITH ROD AND CAMERA.

F. W. HALSEY, M.D.

Leaving Boston at 9:45 p. m., Bangor is comfortably reached at 5 a. m. An hour for breakfast and a cigar, and we are again whizzing along, over a route well worth enjoying by daylight, our objective point being Ashland, the terminus of one branch of the Bangor and Aroostook Railroad. Through a virgin forest, for much of the distance, but little disfigured by fire or depleted by the woodman's ax, Ashland is reached at 12:30 p. m. A good dinner, and we are once more pressing into the wilderness, in a comfortable buggy, behind a good horse and over a good road. Portage lake is reached after a 10 mile drive. There our guide met us with canoe, having come down the river for that purpose. We then had a canoe trip up Portage lake 5 miles, and up Fish river 15 miles. The wind was blowing great guns on the lake, and dead ahead. We must get there, however, and we make the start. I have not been in a canoe nor touched a paddle for about a year, but that is ignored, and I strain every nerve in the effort to keep up my end. It proves the fiercest wind against which I ever paddled, and much of the time we are able to hold our own only by the greatest effort. Two hours of hard work take us to Orcutt's camp, a short 3 miles on our way. Discretion seems the better part of valor, and we decide to stay over night with Orcutt, who has a beautiful set of camps, and makes us comfortable. Up and on the water at 4 o'clock next morning. Eighteen miles ordinarily would not be much of a paddle, but when 13 of it is up a swift and shallow stream, it means a great deal of hard work. But, oh! the joy of it.

It was Sunday, August 12, the Sunday following that terrible Saturday when Boston sweltered at 98 deg. Was it hot here? Decidedly no. We slept cold under 2 blankets and a quilt. The sun was welcomed gladly as it crept above the trees. The sky was never so blue, the water never so clear, and with deep, full breaths we drank in the pure, delightful air, only dispensed in God's country. The gulls saluted us shrilly, as we sped along. A flock of black ducks rose with whir and splutter, circling to our left to let us pass. Soon we entered the river, deep, silent, its banks shaded by beautiful trees of almost every variety, all fresh and green and casting their perfect shadows into the quiet water at their feet. At every turn, a new, beautiful picture. My paddle is cast down, and I surrender

myself entirely to the panorama. The guide is an expert canoeman, and we proceed almost noiselessly. Sweeping around a sudden turn, we come on 2 deer, standing on a sand point, one drinking, the other watching. They see us, but we are absolutely quiet, and they show no fear. The instinct of the hunter is strong on me, and I reach for my gun. Ah, I remember I brought no gun this year, but a camera. It is one of the late folding contraptions; it does not spring open as it should, but is pried open finally. In pulling out the bellows to get the proper focus, the camera being new to me, I pull too hard and off goes the bellows from its trolley. No time to fix this. A glance is taken at the deer. Charlie has simply held the canoe steady, making no sound, and the deer are standing quietly, not much over 50 feet away, waiting to be "took." Steadying the thing as well as possible, I press the button. At the sharp click, their flags go up, and with a startled whisk, they are off. By no means a novice with the camera, I have ample time now to reflect, and realize that my photograph may turn out well as a landscape, but it will never draw a prize as a picture of game. Never mind; the picture impressed on my retina is perfect. Nothing can spoil that. Now we are in quick water, and now for 13 miles it is all poling; rather hard work for Charlie, but more or less exciting for me.

Hugh's brook, a clear, cold stream, flowing into the river, offers a convenient spot for breakfast, and a chance for a few trout. It is not easy to get at my rods, so I cut a pole. Charlie has a short line and hook in his pocket; a nail serves for sinker, and we start in. Fortunately, we begged ½ dozen worms last night, or we could not eat trout for breakfast. The bottom is hardly reached, when a tug is felt, and a ¼-pounder is pulled in. Once more, this time a ½-pounder gets there first, and pays the penalty. In 5 minutes we have enough for breakfast. Charlie proceeds to get it ready while I continue fishing. This is the best I have had in a year or more, and although the method is deplorable, we must have fish, and how do I know that the fellows have trout in camp; so I keep on fishing till we have 25 nice ones; in other words, till my worms give out. When 2-3 of our way up stream, we are obliged to carry our boat and luggage around a fall, but not a long or hard carry. A little

more hard poling, and we are once more in dead water, and soon in Big Fish lake, our destination, one of the most beautiful lakes I have ever seen. Dotted with many picturesque islands, surrounded by green hills and mountains, its waters clear as crystal, it furnishes a scene ever varying and beautiful. From the clinging mists of early morning, to the resplendent sunsets, it is always a beautiful picture. A short paddle, and we are within hail of our camp, "Injun Camp." The Admiral's salute is not in it to the welcome accorded us by those in camp, and we are soon in the hands of our friends. It has been my privilege to spend many vacations in the woods, and I have tried tenting and living in the typical log camp, but never before in a spot so ideal. Three good sized tents, the largest having a fly, covering the tent completely and projecting 15 feet in front, made a fire under the fly practical, and allowed us to sit out doors, yet protected us from wet weather. The usual bed of fir boughs was supplemented by an arrangement of logs and small limbs, put together as only expert guides know how. Through the ingenuity of some of our party tables, washstands, seats and even rustic and comfortable chairs had been built. With an ample larder, furnished from "Pierce's best," who could refuse to be happy? There was but one drawback to this paradise. We were not to enjoy its beauties and comforts alone. Though so far from home, and so difficult of access, 40 others had spied out this particular spot, and located at different camps on the lake.

Then followed days of supreme delight. We could be as lazy as we wished, meals at any hour, and have what we ordered. There were but 4 of us, all congenial, and the 2 best guides in the region. We were more than fortunate, but this was not all due to luck. Freeman is an old campaigner; that was one of his stamping grounds, and he had tried the McGowen brothers, George and Charlie, before, and they were not found wanting. So much is dependent on intelligent and willing guides. It makes all the difference between a successful, happy trip, and a dismal failure. Indeed, that whole beautiful region was completely hoodooed for us, owing to the experience of 2 intimate friends, who went up there and fell into the hands of the Philistines. One of our pleasures this year consisted in trying to get some good pictures of game. Have you ever tried it? It is as difficult as taking a picture of a 2 year old baby; worse, if anything. It is difficult to take a large camera from place to place in the woods or even in a canoe, and with the small affairs used for snap

shots, it is almost impossible to get near enough to the game to get a good picture. Notwithstanding this, I had some delightful morning and evening trips trying it. Occasionally it was too early in the morning, sometimes too late in the evening. Again, after making a snap, I would find that the sun had hidden its face under a cloud just at the moment of my exposure. Another time the sun would persist in shining directly in the face of the lens, and the deer would not change their pose nor allow me to move either the sun or myself. Many days were cloudy, and nothing could be done against a background of trees. In only one exposure where deer were included in the picture, were the conditions all with me, and I have already told of my discomfiture in taking that. The old saying, "you see the game when you haven't a gun," applies equally well to camera hunting. I was particularly anxious to get a picture of an old bull moose. Let me tell you how near I came to it.

We were on our way home, having been up a river offering a good chance to see a moose. Half way down the river, we came to a loggers' camp. There we stopped for lunch. Five minutes after leaving the camp we noticed a peculiar reddish looking branch protruding from the bushes away down the river. We had converted so many stumps, branches and things into deer, only to find them change back into plain inanimate objects as we drew nearer, that we kept still. Presently the seeming bush moved, and resolved itself into the antlers of a large bull moose. He saw us fully as soon as we did him. He waited until we were within 75 yards of him, then turned his head and horns away from us, and sneaked into the bushes. We could see his huge hind quarters as he slowly moved away, but he was so concealed by the bushes that no picture could be secured of him. He would have been an easy mark with a rifle, but alas, we could not shoot him; it was yet the close season, and it would not do. His horns were still in the velvet and it would have been impossible to keep the head; besides we had no gun.

The lake on which we were encamped furnishes the best of trout fishing most of the season, the trout rising freely to the fly. As in most of these large lakes, the trout are capricious, and at times, though breaking water freely all around us, no fly which we could select proved sufficiently seductive. While we were able to take a few trout every day, it was not what would be called good fishing. Charlie spoke of a pond several miles through the woods, where he believed we could get fine fishing if we could strike

them right; and yet even there he had seen a man fish all day without a rise. There was no boat on the pond, and having decided to go over, George and Charlie proceeded to lug in a canoe, 4 miles through the woods over an indifferent trail. As my time in the woods was to be briefer than that of the others, I was given first chance. We reached the pond about 5.30 a. m.

Adjusting our rods quickly, we began our work first near the inlet, where we soon caught a few little fellows,  $\frac{1}{4}$  to  $\frac{3}{4}$  pounders. Then at Charlie's suggestion I moved to a spot where he knew there were big ones, if only they would bite. At once the fun began. My first strike, a big fellow, I lost, together with part of my line and my leader. By the time it had grown

too dark to fish, we had taken  $\frac{1}{2}$  dozen, ranging from  $1\frac{3}{4}$  pounds to 3 pounds; doubles the last cast, one of  $1\frac{3}{4}$  pounds, the other 3 pounds.

A deserted cabin by the shore offered us a shelter for the night, where after supper we sank to rest on the bough beds prepared a year before by some other campers. At 4:55 next morning we were out in our canoe and at work. At 8 a. m. we quit and counted up our spoils, 42 trout weighing between 60 and 70 pounds! Never have I seen another such string of trout. A photograph of them was taken, breakfast eaten, and we started back for camp, which we reached by 1 p. m.

A few days more of this idyllic life, then the sad return to civilization and its ceaseless, remorseless grind.



AMATEUR PHOTO BY J. DUNBAR.

CLOSE HAULED.  
Taken with a Goerz Lens.



AMATEUR PHOTO BY J. DUNBAR.

THE OTHER TACK.  
Taken with a Goerz Lens.

This is the way a Billville justice laid down the law: "Mr. Bailiff, take the lawyer to jail for 10 days, give the woman a divorce, whip the husband and bring in a jug of liquor."—Atlanta Constitution.



## A TRIP FOR TROUT.

DR. J. S. EMANS.

Photos by the Author.

In 1861, when my father, an Englishman, sailed from Leyden, in Holland, to America, I am sure it was because he had heard there was good fishing here. At any rate, the fishing microbe has always been rampant in the male line of our family. Although I am able to keep this microbe fairly quiet most of the year by feeding him on stories from RECREATION, the summer's heat develops such a host of these pleasant nuisances, that about the 1st of August every year they give me an attack of acute *Fishitis*, and I have to seek the Northland for a cure.

Last year, with Wm. A. Dutcher, I left New York August 9th for Boston. The next day we took the Dominion Atlantic steamer to Yarmouth, Nova Scotia. After a trip through the beautiful valley of Anapolis bay, we stopped at Wolfville, and drove 3 miles to Grand Pré. There

tigouche river, at the head of the bay of Chaleur, was the best place in the world to satisfy our desires, we started on the



ROCKS AT HOPEWELL CAPE.



EVANGELINE'S WILLOWS, GRAND PRÉ.

I took snap shots of Evangeline's well and willows, and the site of the Arcadian smithy; also of the bridge over the Gaspereau. Sad it is that fact and fancy are often so far apart. Longfellow never saw the land of his poem. Still, one loves to linger beneath the willows and gaze at far off Blomidon.

Those who have visited Quebec, and Lewis opposite, and have seen the tremendous fortifications, must have been impressed with the fact that England has planted one foot there. I never discovered where the other foot had been planted until I went to Halifax. There I saw the evidences of her lingering love for America; but we were not especially interested in forts and footprints. We were looking for trout.

Hearing that Campbellton, on the Res-



ROCKS AT HOPEWELL CAPE.

hours the river, which is one third of a mile wide, empties and is refilled by a tidal wave, caused by the 60 foot tide in the Bay of Fundy 25 miles below. At times the water rushes up the river in a wave 5 feet high. We were well repaid by the sight; also for the 24 mile drive to Hope-well cape, at the mouth of the river, where the rocks are carved out in fantastic shapes by the wonderful Fundy tides.

Leaving Moncton at 11.22 a. m. we reached Campbellton at 17.45 p. m. The next morning we drove 4 miles up behind Sugar Loaf mountain to Parker lake, which although only  $\frac{1}{4}$  mile wide by  $\frac{3}{4}$  of a mile in length, is famous for its trout. The lake is owned by Mr. Pritchard, who charges \$1 a day for each rod. After some sad experiences with certain fishermen whose composition was mostly pork, he allows no one to catch more than 10 pounds a day. The trout are peculiar in that they will not look at a fly, and have appetite only for grasshoppers. With a bottle of hoppers, and a boy to row us to the best spots, we fished till noon. Then we had our first fill of trout, prepared in the most delicious manner by Mrs. Pritchard. Bill ate so many, I noticed signs of distress in the region of his belt during all our afternoon fishing. We caught in all 40 trout, the largest  $1\frac{1}{4}$  pounds and many 1 pound. The small ones, facetiously called "sprats" by our guide, we returned to the lake.

The following day being August 15th and the last for salmon fishing, we decided to try our luck in the far famed Restigouche, whose waters lapped the back of the hotel. We were told we were not likely to catch any because of the lateness of the season, our lack of proper equipment, and the fact that the best waters were leased by the Metapedia Club. As it costs \$10,000 to join the club, and there were no vacancies, we gave up that idea. However, we thought our trout rods and landing nets all right, until a gentleman showed us his salmon rod, which looked like a telegraph pole, and his gaff, like a shepherd's crook. We wilted, but bought some double hooked salmon flies, took our heaviest bait rod, a borrowed grilse rod, and a freight train 10 miles up to Flat Lands. There, for a small consideration, I got permission from Mrs. McDonald to fish her waters in the Restigouche. With Tom and Dan Delaney as guides, in a Gaspé canoe, we cast our 75 cent flies all day, with the results of one rise from a grilse and 4 aching wrists. We had at least been swell and fished for the lordly salmon, and we were satisfied.

A day later we visited the Powell, and saw a sight calculated to make an angler lie awake nights. In a narrow strip of shal-

low water, staked off between 10 islands, were 300 salmon, averaging 20 pounds each. These had been caught in a weir, and were to be kept there until September, when they were to be stripped of spawn and returned to the river.

With fly and bait, in the Restigouche, we were rewarded with 2 fair catches of beautiful silvery sea trout, averaging about a pound in weight. The first run of trout had been long before at the head waters of the river, and the second run was only just beginning, so we were informed by our Indian guide, Tom Condo.

Hearing of some wonderful catches of 5 and 6 pound brook trout in Indian lake, 22 miles South of Campbellton, we decided that was the place to go. Many had heard of the lake, but few had ever been



THE INDIAN LAKE EXPRESS.

there. As a consequence, it took one evening and all the next day to find a guide to take us there. One morning at 8 o'clock we started with Tom Chorette and drove and walked 16 miles over a rough road into the woods. One stop was made to "boil the kettle," which term designates meal time in camp throughout New Brunswick. Having gone as far as possible with the wagon, our provisions, tent, feed for the horse, etc., were transferred to a sled and we started over a trail 6 miles to the lake. There never was a more woods-wise horse than Dick, who was a constant source of wonder and admiration. He certainly was half human. Simply by word

of mouth, he was driven over fallen trees, through mud, up and down almost perpendicular ridges. To be sure, the sled was sometimes overturned, but I never blamed Dick.

We were at last in the "forest primeval." Spruce, hemlock and pine, with the most magnificent white birches were on every hand; but we missed the woody odor of our Adirondack balsams.

Many moose, caribou, and a few deer tracks were seen. Reaching the lake a little ahead of our guide we saw a beaver swimming a short distance from shore. While we watched him he dived and slapped his paddlelike tail on the water 11 times as a warning that there were visitors on the lake. During the 5 days of our stay we saw him every morning and evening. He used to come swimming in a zigzag manner toward us, and wonder what we were doing on our raft of logs in his preserve. Sometimes he would dive quietly and again slap his tail, sending the spray 5 feet in the air. We came to love him and would have liked to exchange cards, but could only exchange glances. The last morning he came within 50 feet of us and we took snap shots of him as he lay on the water and as he dived. We broke his dam and left a stick projecting from it. During the night he cut the stick half in 2, in his effort to remove it.

The lake was full of trout, and evenings, just before dark, the water fairly boiled with rolling, leaping specimens. Such gamy ones I never saw. It was exciting, amusing, provoking, to spend 5 or more min-

utes landing a ½ pound trout when one wished to get him off and try for some big fellow who rose near. We got plenty of one, 1½ and 2 pounders, but none of the big fellows we heard about. It took 12 minutes to land the largest. Our largest were caught on a red tag Parmer, and a grilse Silver Doctor on which was hooked a trout eye.

Sleeping on a bough bed, with our clothes on, in a small tent, listening to the rain drops fall, and unfortunately sometimes feeling them; hearing the hoot owl, and the snore of our guide, who was a past master in the art, are things enjoyable for a time; things which on return to civilization make the warm bath, clean clothes, good dinner and clean bed most delightful.

We went for trout and we got them, we were hungry for trout and we ate them until it seemed we would never want another. Our trip had been a success, and we put up our rods satisfied, with no desire to see them again for another year.

On our trip out we saw, at Fourteen Mile lake, where a moose had been killed and cleaned, although the law was not yet up.

There are a large number of places in Northern New Brunswick, in the vicinity of Campbellton, where there is excellent fishing. The one drawback is that the best waters are leased. It is often possible to make arrangements with the lessees, and either in their waters, or those not leased, the desires of the most ardent angler may be satisfied.



AMATEUR PHOTO BY H. O. BJORNAAS

GREY GOPHER.

Winner of 27th Prize in RECREATION'S 7th Annual Photo Competition.



AMATEUR PHOTO BY E. S. WILSON.

THREE JOLLY TARS.

Winner of 35th Prize in RECREATION'S 7th Annual Photo Competition.



AMATEUR PHOTO BY CHARLES B. WRIGHT.

A NIGHT IN CAMP.

Winner of 34th Prize in RECREATION'S 7th Annual Photo Competition.

## TWO TENDERFEET IN THE GRAND DISCHARGE.

ROBERT FROTHINGHAM.

While spending a part of my vacation in Quebec last July my attention was attracted by the following advertisement of a local dealer in sporting goods:

"Have you ever seen a ouananiche?"

There is one on exhibition at our store."

Impelled as much by curiosity to learn how the word was pronounced as to see the fish itself, the next morning found me at the store in question, only to find displayed a mounted specimen of what might have been a beautiful fish when taken from the water. My disappointment must have been apparent to the courteous clerk who inquired as he looked me over:

"From the States?"

"Yes," I replied.

"Going up to the lake after 'wannan-ishe,'" he ventured, glancing at my wife who stood near, with a helpless expression on her face, wondering what my reply would be.

"Well, that depends. I thought you had a live specimen of that fish here on exhibition, and I wanted to see it."

"They are brought fresh from Lake St. John every day," he replied, "you can see one that has been out of water less than 24 hours;" and stepping to the telephone he called a fish dealer who appeared a few minutes later with a magnificent specimen hanging by the gills from his finger. To my wondering eyes the fish looked fully 2 feet long and I would have said it weighed 8 or 10 pounds. As a matter of fact, however, there was but little over 3 pounds of fish.

"How are those big fellows caught? With a spoon?" I inquired, recalling my only fishing excursion since a country lad, trolling for bluefish off Fire Island.

"No," he replied; "they are caught with the fly, up in the Grand Discharge. It isn't considered sportsmanlike to troll for the ouananiche, and there is little of it done up at the lake. Would you like to see some tackle?" In a moment, for the first time in my life, I held a jointed rod in my hand and was trying my best to look wise as the ambitious salesman talked glibly of the best rods for the ouananiche. Opening a wallet full of flies, he gave me a dissertation on the superior merits of Jock Scott, Silver Doctor, Hare's Ear, etc., while my wife discreetly turned her attention to something on the other side of the store. I didn't have the nerve to tell him that my knowledge of rods and flies was limited by what I had seen of

them through a plate glass window of a sportsmen's supply house; that I had never essayed a cast nor sat in a canoe; that I knew no more of the art than a child; that, in fact, I had no earthly right to be wasting his time; and so, as gracefully as possible, I made my escape, in the belief that I had not given myself away.

Nevertheless, in that brief interview I had made up my mind that we would go to Lake St. John and try our luck. The next day found us on our way for a ride of 200 miles North from Quebec through the Laurentian mountains, the "Canadian Adirondacks," up the Quebec and Lake St. John railway, to Roberval, the Northernmost settlement between Quebec and Hudson's bay. The railroad runs directly to the Hotel Roberval, the only hostelry in the place.

As I had been given to understand that fishing privileges would have to be bought, it was a pleasure to learn that the proprietor of the hotel had leased from the Provincial government all the ouananiche waters within a radius of several days' journey from Lake St. John, and that they were all free to guests. The next morning we started on the steamer Mistassini, for a 25 mile sail across the lake, to the Island House, at the head of the Grand Discharge. There the waters of the lake begin their descent, and there is first felt the impetus of the current which forms the terrific rapids extending all the way to Chicoutimi, 40 miles below, where they empty into the Saguenay. The strength of the current was apparent from the powerful steamboat itself which, having rounded the point of the island, was hurried along by the rushing water at a rate that made it necessary to round to before a landing could be made.

Luncheon over, a birch bark canoe and 2 trusty guides, Joe Morel, one of the oldest and best known of the Canadian voyageurs around the Grand Discharge, and his son, a young fellow of 20, were on hand, ready to transport us to the ouananiche pools below. Mrs. Wife looked at the frail craft, in the bottom of which I had taken a seat, and remarked sententiously,

"Two hundred and ten pounds besides the weight of the guides is enough in that cockleshell. I'll stay here and finish this novel, while you go fishing."

There being but half a day at our disposal we went down stream about 6 miles,

hugging the Eastern shore of the Discharge and beaching the canoe in a quiet little cove. The guides dragged it up in the bushes and we started overland for a walk of a mile and a half to the fishing grounds. Joe Morel could talk but little English and I knew no French, so there was nothing to do but follow my leader. Incidentally I gathered the impression that Joe and his son would rather walk than paddle, in spite of his oft repeated assertion, "Portaj de canoe, no time feesh."

Ever as we walked through the rough trail that had been hewn out of the underbrush, I could hear the reverberating roar of a distant waterfall, which penetrated the silence of the woodland and forced itself on the senses with an insistence that could not be shaken off. A sudden turn in the trail took us out into the open and in full view of the *grands chute*, the first falls of the Grand Discharge, a roaring fall of some 15 feet, extending like a huge dam entirely across the stream, which was in the neighborhood of 1,000 feet wide, and terminating in a series of fearful rapids. To me they seemed as voluminous and powerful as the whirlpool rapids of Niagara and infinitely more terror striking and awe inspiring because of the primeval grandeur of the scene.

Huge boulders of gneiss and granite as large as a house were lying about on every side, with a profusion that bespoke some terrific convulsion of the earth's surface centuries ago. The surge and roar of the rushing waters were appalling. Almost overcome by the terrific spectacle I turned to Morel, the guide, and asked him where we were going to fish.

"On de rock we feesh," he replied, pointing to a huge boulder that jutted out from a point near where the swirling waters rose and fell like the swell from an ocean liner. Suiting the action to the word, he unlimbered the rod and ran out the line, with a big grey fly on a double hook at the end and another smaller fly 2 feet above. The incongruity of the situation was almost painful and as the mind sometimes reverts to the ridiculous under excitement, the old lines from "Mother Goose" came trooping through my brain,

"Simple Simon went afishing  
For to catch a whale,  
And all the water he had got  
Was in his mother's pail."

The idea of throwing a hook into that cauldron of rushing water, with the expectation of catching a fish, was too much for me and in a dazed condition of wonder and incredulity I told Joe to go ahead while I sat down on the rock to watch him. I had never seen a fly cast. It was mighty interesting to watch the clever

twist of the wrist which carried the line 30 to 50 feet out into the stream and dropped it as deftly on the water as if it had been laid there by a fairy's wand. Suddenly the point of the rod went down and Joe put the rod in my hands that I might experience, for the first time, the sensation of a lusty fish fighting for his life on 30 feet of silken twine run out from a 7 ounce rod.

Once more a case of unconscious cerebration. The only thing I could think of was an incident in my boyhood in the country, when I vainly tried to navigate a bull calf with a rope out of a 10 acre lot. How that fish did pull! Instinctively I began to reel in the line. Joe's experienced eye noted that I was proceeding with more zeal than knowledge and he cautioned me to take it easy. He had scarcely spoken when the line suddenly slackened and like a bar of burnished silver flashing in the sunlight, a handsome fish leaped into the air twice in succession. Away went the line, singing through the reel.

"No so fast," cried Joe, apparently as much excited as I was; and he grabbed my hand away from the reel, to prevent my making a fiasco of a fine chance. With a look of anxiety on his face which betrayed only too well his fear that I would lose the game, yet too experienced a guide to offer to take the rod from my hands, he directed me as a mother would a child, until little by little, after about 15 minutes, the fish was brought up close by the rock and Joe cleverly scooped him in with the landing net.

"Wannaneesh," Joe said laconically, as he held up the fish to view.

"How big?" I queried.

"Oh, leetle more dan pound and half," came the astounding reply, for I was satisfied there had been fully 5 or 6 pounds of fish on the end of the line. He was well hooked, having swallowed the fly, which jolted my pride a little for already I was becoming impressed with my ability as an angler.

For the next hour or so I held the rod and made my first attempts at fly casting, during which time I hooked Joe's trousers, my own back, a big log lying on a boulder high above my head, and the rock itself. I seemed able to land the fly on almost any spot within a radius of 50 feet except in the water. The precise measure of rank disgust experienced by old Morel was a mystery to me, for every time I looked at him he was either busy lighting his pipe or looking the other way; a most considerate guide. I began wondering if, after all, it was unsportsmanlike to troll for ouananiche, for I was becoming satisfied

that the spasmodic stabs I was making in the atmosphere, in my efforts to cast the fly, were unlikely to raise a fish. Turning to Morel, who was lying prone on a pine log that had been thrown up by the high water, I said,

"Joe, come here and show me how to handle this d—d pole."

With a patience that discounted Job's, Joe stood by my side and demonstrated as best he could that deft movement of the wrist and forearm that kept the line alive as it whizzed back and forth through the air and dropped the fly in the turbulence beyond, cleverly drawing it through the creamy scum that the counter currents form in spots here and there, under which the ouananiche lie in ambush for the insect life that comes down through the rapids and gathers in eddies on the surface. I soon caught on, and before long was making respectable casts, sawing the line, shuttlelike, back and forth with my left hand as I drew the fly through the water. Meanwhile I had got soaking wet from the waist down, from the incessant dashing and surging of the swell thrown out by the furious rapids a few yards beyond.

I had 3 or 4 rises, but either was not quick enough with the rod or was too quick with the reel, and the gamy fighter would get away every time. Several times Joe took the rod to relieve my tired arm and every time he did so he would get a strike, after which he would magnanimously put the rod in my hands for me to land what was invariably a well hooked fish. That was all right, but I was getting tired of that sort of attention, even though an amateur of amateurs. With a determination to do or die I once more took the rod, and did not yield it again that afternoon.

It was nearly 5 o'clock when I made my first strike that held fast, and I was more than proud. Morel scooped a handsome 3 pound fish into the landing net at the end of a 20 minute fight. I caught 3 more before we quit, and we returned to the Island House with 9 beauties, 4 of which were to my credit. I lost fully a dozen during the afternoon, which in all probability a more experienced angler would have landed. Mrs. Wife was surprised to see the result of the afternoon's sport, which averaged 2 pounds each, and still more surprised to learn that I had hooked my share; all of which, together with the undue attention which the blackflies had devoted to her during her half day's sojourn alone, settled the question of her accompanying me in the morning.

Shortly after 7 o'clock the next morning

we embarked for a 10 mile sail in the canoe, old Joe in the stern, young Joe in the bow, my wife and me back to back. The wind was blowing stiffly and we scudded down the first 3 or 4 miles of the Discharge, in the center of a swift though smooth current. It is difficult to describe the sensation of shooting over the water in a bark so fragile that it seems to draw scarcely an inch of water. The rapidity of the descent and the smooth, oily surface of the unbroken current created the impression that invisible hands were reaching up from below to drag the canoe under.

There were 2 short, sharp rapids to be run before the portage around the *grande chute* is reached. These the guides will run willingly with one passenger, but not with 2. Each of these rapids involves a 5 minute walk through the woods on the mainland. These were taken by my wife and me in turn, while the canoe shot around and down with the other. Following the channel of the discharge a few miles farther down, across the stream from and below the long portage of the previous day, we arrived at the head of the *grande chute*, at the foot of which we fished the day before and whither we were again bound, although I had no idea at the time just how we were to get there in a canoe. This portage is a comfortable footpath, cut through the woods and about a mile long. There, for the first time, we saw the birch bark canoe hoisted on the shoulders of the guide, young Joe. He trotted off with it, while we came after with old Joe, who carried the rods and the luncheon. We could hear the roar of the rapids as we walked, but could not see them for the dense underbrush. Soon we were at the end of the portage and the canoe was put down on the margin of a beautiful cove with as picturesque a beach of fine sand as may be found along the Atlantic coast.

Then we reembarked, amid the roar of the rapids, which was still in our ears, though we could not see the waters. A few swift strokes of the paddle and we rounded a point, which took us in full view of the rapids themselves and the immense boulders from which we had fished, the day before on the opposite side of an expansive bay about  $\frac{3}{4}$  of a mile wide, which had been worn away by the unceasing action of the waters in their mad plunging through the rapids of the *grande chute*. A strong desire to turn back filled me for an instant, but there was no time for argument, as we were already well on our way across the bay, and thereby to a certain extent dispersed the fearful force of the rapids which had created it. Ten minutes more and we were in the midst of

them, the canoe pointing now this way, now that, now up the stream, now down, ever guided by the unerring stroke of the paddle and prevented from what seemed inevitable swamping; rising to the waves with a peculiar sweep of the paddles that fairly lifted the canoe out of the water. Thus we zigzagged across the turbulent flood. To have attempted a passage by a direct line would have meant certain destruction. How the guides do it, no one knows. It was enough for us that we were safely shot across the stream without shipping a drop of water, and for what? Ouananiche!

Old Joe evidently thought I had received sufficient education the previous day, for on our arrival at the pools at the foot of the rapids he left me without a word, with young Joe as an attendant, and, like a gallant *voyageur*, devoted himself entirely to "de Madame," as he deferentially called her.

He escorted her to the same rock where I had received my first lessons. There old Morel labored as patiently as he had with me, hooking the first fish or 2 and handing her the rod while he used the landing net.

Domestic responsibilities have rendered Mrs. Wife self possessed and dignified, with an unruffled calm which, to use a metropolitan metaphor, seldom slops over; hence, I needed no explanation when to the rock where I stood submerged to my knees on a lower ledge, some 50 yards distant from her, came a muffled scream and I saw her dancing a hornpipe in a space where good footing was dependent on remaining quiet. She had hooked her first fish and he was describing graceful curves in the air, leaping half a dozen times in succession, in a vain endeavor to dislodge the hook, the water dripping from his brilliant sides as he fell back each time with a splash. She played with him fully 15 minutes, Joe finally landed him. The fish weighed  $2\frac{1}{2}$  pounds.

Half an hour later Mrs. Wife hooked a pair of them, one on each fly, and they made a beautiful display as they fought for their liberty. She had the good sense to hand the rod to Joe, but even that old veteran was not equal to the task, a very difficult one I have since learned, and both fish got away, one taking the fly with him. It was a case of the survival of the fittest, and the gallant fish earned their liberty.

In the face of rare luck, we stopped to lunch, on ouananiche and bacon, crackers and cheese, with a hard boiled egg on the side, washed down with strong tea. We both acknowledged that we had fared worse many a time and paid more. Shortly after noon heavy clouds began to scud across the sky and settled down to a heavy

rain, which continued the rest of the afternoon. The wind and waves carried the scum away from the rocks from which we had been fishing; so, packing up our stuff, we took the canoe to a small island near, where we remained the rest of the day. I had gone around on one side of the islet to try my luck away from the others, when Joe came after me in a hurry, saying excitedly,

"Big feesh jomp in de foam."

I hastened back just in time to see a tremendous fellow leap fully 3 feet in the air from the middle of a broad patch of scum about 35 feet distant. Even as I cast for the spot, up he came a second time. I had learned to cast fairly well, and it was with comparative ease, which brought a shout of approval from old Morel, that I pulled it through, leaving a little wake behind. Another cast, hoping and praying that my good angel might be somewhere around, when down went the tip of my rod till it touched the water. Something ripped out from between my lips which Madame would not repeat, and the battle was on.

Six times that magnificent fish leaped from the water, into which I had walked waist deep in my excitement, and at each jump I received an electric shock which made me feel as if I had touched a live wire. I have not the words to express my sensations at that moment. The incident stands alone, absolutely unique. Nothing in any other of my experiences can be compared with it. I played that fish, or rather he played me, 32 minutes, by Mrs. Wife's watch, before he yielded the fight and came into the landing net.

"Big feesh," indeed, that "jomp in de foam." He weighed 4 pounds, 7 ounces that night at the Island House. He was the biggest catch of the day and to have remained longer would have been like returning to an *entree* after dessert had been served. I was satisfied to return, feeling much as the old patriarch probably felt when he said, "Lord now lettest thou thy servant depart in peace."

For the first time during the day I stopped to admire the quarry I had taken. How beautiful the peacock blue shade and hues that o'erspread his sides, but that soon disappeared, giving place to well defined silver and black, with the black crosses and spots. How graceful and artistic the lines which tapered the body, creating the impression of length and weight! Noting also the breadth of the powerful tail and the strong fins, it was not difficult to understand how he held his own in the swirling eddies of the *grande chute*.

When Morel gathered up the spoils there were 26 fish, aggregating 52 pounds,



the majority running about  $1\frac{1}{2}$  pounds each. Several weighed 3 pounds and some but little less. We lost at least 15, and some half dozen we threw back because of their small size.

As we started away from the little island, homeward bound, we had an opportunity of witnessing once more the almost superhuman skill of our guides in navigating the canoe. In a driving rain, with a stiff wind blowing across the bay, we started to cross the foot of the rapids we had come over in the morning. It was a different proposition in the face of fitful gusts of wind, which added to the turbulence and choppiness of the water, to say nothing of over 50 pounds additional weight in the canoe. Our crossing in the morning had been made in silence. I noticed this time, however, that every few minutes old Joe would drop a word in the musical French *patois*. It would be answered by an eloquent "Oui" from the son, immediately followed by some particular stroke of the paddle which turned the canoe at right angles from its apparent course, to hold it motionless amid the churning foam and avoid running into the crest of an oncoming wave which threatened to engulf the frail craft and which in the twinkling of an eye would either be turned aside by a sudden change in the current or cut off at the crest by a stroke of the paddle. It was marvelous! While my heart nearly stopped beating I simply sat still and wondered at the almost miraculous feats performed by those *voyageurs*, and whether we would really reach the shore without a mishap. Mrs. Wife said it was enough to give a person "nerves," and I agreed with her.

On the way down in the morning we had passed though a portion of the channel which was divided by a small island about 100 feet from the mainland, and not far above the head of the long portage. A big rock jutted out from the main shore at a point midway of the length of the island opposite. I noticed that we shot past the little island like a streak, without appreciating that we would have to pass the same way on our return. On the way back that evening we hugged the shore closely all the way up to the projecting rock in order to avoid the effect of the wind and current. When we reached that

point, however, it was more than apparent that no canoe could be paddled up that short ascent by any 2 men. The stream was running like a mill race and eddying around the big rock like a whirlpool.

What to do was the question in my mind, when like a flash the canoe was turned just before the rock was reached and shot almost at right angles across the stream, both men bending to their paddles with all their might and main. Just as it seemed inevitable that we would be swept past the lower end of the island and into the rapids, a final stroke sent the nose of the canoe within a foot of the sheer rock and another turn brought it up alongside as gracefully as a swan.

"Bon!" ejaculated old Morel, as he braced his paddle against the rock and drew a long breath, and I understood just enough French to appreciate how he felt. The remainder of the run home was uneventful, except that the rain continued falling heavily. By the time we reached the Island House there was about an inch of water in the bottom of the canoe, and we were sitting in it; but there were 26 ouananische and 2 18 carat guides keeping us company and we cared nothing.

The next day found us on board the *Mistassini* on our way back to the *Roberval*. Beemer spoke the truth when he said our experience in ouananiche fishing would spoil us for future sport with the fly. We had been initiated at the top of the ladder and further experience would be in the nature of a retrogression, unless we should return to Lake St. John, for we had met and conquered the greatest game fish in North America.

As I look back on that day's glorious sport at the foot of the rapids of the *grande chute* in the Grand Discharge, it makes me feel humble. When I think of the gall I had to venture to lure that greatest of all game fishes without any experience in handling a rod or casting a fly, I shudder. That it should have been on the cards for a *genus loppestre* like me to land that kingly  $4\frac{1}{2}$  pounder that came to net at the eleventh hour, and in one brief day to demolish the traditions of sharps who have been writing for years on the experience and expertness necessary to angle successfully for the ouananiche, makes me proud.

---

Her Fashionable Friend—Why didn't you bring the baby?

The New Mamma—I did want to, but there wasn't room in the carriage for her and my doggie, too.—Chicago Record-Herald.

## WILD SHEEP IN CAPTIVITY.

HARRY E. LEE.

On a recent hunting trip in Old Mexico I had the pleasure of spending a few days in El Paso, the gateway to that old and little known but interesting country. While enjoying the balmy sunshine and making the acquaintance of a number of royal Southern sportsmen, I had the good fortune to be allowed the privilege of taking a photograph of this noble little animal. The history of its capture is as follows:

In February, 1902, Pedro Sorrillo, a Mexican, was hunting in the Cerro Chino mountains, State of Chihuahua, and shot the mother sheep. The lamb was only a few days old at the time and was carried in the saddle in the hot sun without food or water. At night a domestic she goat was procured for it, and it nursed readily. It was kept with this goat continuously until last June, when Mr. C. H. Townsend, of Townsend-Barber Zoological Company, El Paso, happened to be in that section of Mexico on a hunting and exploring trip, and secured the prize from the Mexican. Mr. Townsend took the lamb 20 miles in a carriage to the railroad and over 90 miles by rail to El Paso, simply tied with a small rope around its neck.

The day before getting on the train with his little charge Mr. Townsend had an interesting experience, and it was only through good fortune that he did not lose the lamb altogether. In the middle of a burning afternoon, while tied in the shade of the rude box car station at Sabinal, it broke its rope and started for the hills. Unfortunately for Mr. Townsend, there was no saddle horse near, and he was compelled to give it chase on foot. Those who have had experience in following a mountain lamb, even though it be of tender age, realize what Mr. Townsend had to contend with. I once had a chase of that kind in Alaska and still bear marks of my rough scramble over rocks and crevices which it seemed impossible for the little creatures to attempt; but they bounded on, heedless of the seeming danger, and soon were safe on the ledges far below, where no human foot could tread. Mr. Townsend was more for-

tunate, and after a run of over half a mile through the low brush and prickly pears, he finally caught the lamb. It felt the separation from its adopted goat mother and wanted to nurse.



MEXICAN WILD LAMB.

In El Paso Mr. Townsend got 2 she goats for it. As soon as it became acquainted with them, which took several days, it nursed energetically, dropping on its knees like a flash and butting the udder repeatedly with its head. Since June it has been eating alfalfa hay, green grass, oats morning and evening, raw potatoes, fruit, bread; in fact, almost anything, even to cigarette stumps, which it ate with a relish. It has a great fondness for jumping. When but a very small lamb it could strike the walls of its enclosure, over 6 feet from the ground, and it now jumps much higher. It is a clean, healthy animal, full of life, yet docile as a tame sheep. It should by all means be in one of our large zoological parks, as it is a rare specimen, and from personal experience I find that these animals are scarce and becoming more so every day. The few that are left will be exterminated unless immediate and stringent laws are enacted for their protection.

---

First Actress—I was beside myself with rage.

Second Actress—You certainly were. Why, you quivered even in the places where you were upholstered.—Life.

## THE BATTLE OF THE PRONGHORNS.

W. T. HEDDON.

The early part of last October I was welcomed by my friend Parker as I alighted from a Pullman which had conveyed me safe to a little hamlet in Wyoming. The hour required to drive 7 miles to the R. B. ranch was fully occupied by queries and replies relative to prospects for the morrow and in recalling our experiences of the 3 preceding autumns together, hunting the keen eyed and fleet footed antelope, which without doubt is the most difficult of approach of all American game animals.

Mr. Parker is the most successful antelope hunter it has been my good fortune to know. Not only does he thoroughly understand the nature of these animals, but he is a born plainsman and mountaineer, and an excellent rifle shot at game, either standing or running. It is rare, indeed, to secure shots at antelope in that section at less than 200 yards, as the country affords too many comparatively level ranges on which grows that far famed, sweet buffalo grass.

Breakfast over the next morning, we saddle and bridled 2 cow ponies, strapped our scabbards containing 30-30 rifles to the saddles, mounted and with wishes of "good luck, boys; sorry I can not join you" from the good wife of my friend, who is equally at home in divided skirts in the saddle, chasing a crippled antelope, or in evening dress in the ballroom doing a 2-step with her most obedient servant, we "gave 'em the steel" and were off. For the first time in nearly a year I was speeding over the former haunts of the buffalo and the rightful owner of our country, the red man. How clear, cool and pure the air! Away to the Southwest some 70 miles the peaks of snow-capped mountains were plainly seen, and I was speechless with thrills of a true happiness from which comes no reactive sting.

We passed over bluffs on which thousands of warriors had camped, and from which they had cautiously scanned the country for miles. The only remaining evidences of their last stand for possession of this former hunters' paradise, against the hand of the white man's greed, clothed in the pretext of "advancement of civilization," are the circles of flat stones used to hold down the circular edges of their tepees. Numerous horns of our buffalo scattered about are still another evidence that civilization has mowed a swath in the heart of every lover of nature.

When about 3½ miles from the ranch we sighted a herd of 15 antelopes about 400 yards away. Unfortunately for us they re-

turned the compliment. Before we could get a rise of ground between us, they had taken fright and had run up a hill from which they could make a more thorough observation. There they halted an instant and while we were filling the air with regrets, Parker, who is the taller and could see into sink holes where I could not, exclaimed,

"See those bucks fight!"

Rising in my stirrups, I saw, some 100 yards to the left of the herd, 2 bucks in deadly combat. Two other antelopes were running around and past them, back and forth, as we supposed in an endeavor to warn them of impending danger. We both took in the situation in an instant, and without further words wheeled our horses and, riding rapidly out of their sight, circled in such a manner as to cut the unsuspecting 4 off from the herd. When we again came in sight all 4 were still there, but the main bunch were running. What a fight! Neither of us had ever before seen wild animals contesting for right as lord and master. At that point the ground was such that by advancing a few rods we would be under cover and could approach unseen to within 150 yards. Keyed to the highest pitch with excitement, not buck fever, I shouted,

"Let's make a run!" and we did, for 200 yards, in the meantime taking our rifles from their scabbards and preparing for action. We quickly dismounted, threw the reins over the ponies' heads, which is just as safe as tying them, and started, bare headed, on a run toward our certain victory. As soon as we came in sight the young buck and doe, which were cutting capers around their companions, circled past us at about 100 yards and joined the herd, then far away. What an opportunity, and how 2 hearts ached to give him the lead, but neither spoke, nor did we raise our rifles. Slackening our pace, we walked, in plain sight of our quarry, 25 yards more, and being within 125 yards, halted to shoot. We spoke not a word, but watched them separate and come together with heads down; heard their horns clash and saw them locked. It was a grand and nobly fought battle, but both were destined to lose, for the next moment my friend raised his rifle and fired. It was not a kill and both bucks circled past us at full speed to join their band. I fired and missed. Parker fired. I shot again, and as my buck fell, in wildest excitement I shouted,

"That's mine!"

Another shot, an exclamation, "Mine's the leader," a few war whoops, congratulations, my Eastman No. 4 shot a few times, our old reliable Marble hunting knives put into action, and it was all over. Our bucks lay within 10 yards of each other and 80 yards from us, both hit near the heart; not because of wonderful skill, but it so happened. Neither moved from where he fell, dying before we reached them to cut their throats. We would not have exchanged places with even a dining-car conductor or a prestidigitator. Our happiness was complete. We did not congratulate each other on account of any skill exhibited; indeed, there was none. Under ordinary circumstances my friend would have killed both

bucks, with 2 shots; but he admitted, "Billie, I was never so excited in my life," and every real sportsman knows why we acted 15 years younger.

What a chance for the camera, if we had only known! There is no doubt we could have approached within a few feet of the fighters, but when we thought of my kodak it was too late to improve the opportunity of a lifetime.

Two days later the head of my buck was expressed to that world renowned taxidermist, C. E. Aiken, of Colorado Springs, and it is now added to my collection of trophies, each of which tells a silent story of the happiest days of my life.

## A PAIR OF SEATTLE RAZORBACKS

This picture comes from Seattle, Wash., and is accompanied by a newspaper clipping stating that the pair of swine shown therein are named D. H. and Virgil Hall. It is said that these men killed 150 ducks, 30

Halls will attempt to justify themselves when assailed, but if I should print some of the letters that have come to me from their neighbors, they would know what other people think of them. It is to be



D. H. AND VIRGIL HALL.

geese and several swans in 2 days. The extent of the slaughter is not so bad as the taste displayed by the men who would thus stand up and be photographed about the corpses of their victims. Of course, these

hoped these 2-legged rooters may realize that they have disgraced themselves and that they may reform.

D. H. Hall is game hog No. 889 and Virgil Hall is No. 890.—EDITOR.

## FROM THE GAME FIELDS.

The man who quits when he gets enough, with plenty of game still in sight, is a real sportsman.

### THE NEWEST ANIMAL TRAPS.

720,911.—Animal Trap. William Gabrielson, Waldron, Mo., assignor of  $\frac{1}{2}$  to Erick Larson, Kansas City, Mo. Filed April 28, 1902. Serial No. 105,074. (No model.)

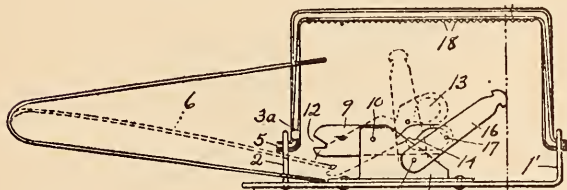

Claim.—1. In an animal trap, a frame, a pair of swinging jaws mounted pivotally thereon, transverse sitting-lugs 3<sup>a</sup> on said jaws, a spring having an opening in its end, said opening embracing the radial portions of said jaws when the jaws are closed, a detent lever pivoted on said frame in position to hold said spring depressed, a slot in said lever, a trigger, a pin secured thereto and entering said slot; said slot being of such a form that the movement of said lever when the trap is set will raise the trigger to an upright position, and that said slot will be engaged by said pin in such a manner as to hold said trigger and lever insecurely in set position.

2. A frame, a pair of swinging jaws having radial portions mounted pivotally on said frame, transverse sitting-lugs 3<sup>a</sup> mounted on said jaws, a U-shaped spring having one end thereof resting on said frame and its other end having an opening therein embracing said radial portions provided with said lugs, when the jaws are closed; a detent lever pivoted on said frame in position to hold said spring depressed, a slot in said lever, a trigger, a pin secured thereto and entering said slot; said slot being of such a form that the movement of said lever when the trap is set will raise the trigger to an upright position, and that said slot will be engaged by said pin in such a manner as to hold said trigger and lever insecurely in set position.

721,321.—Animal Trap. Christopher C. Nesmith and Joel L. Brewer, Manchester, Ala. Filed November 26, 1902. Serial No. 132,954. (No model.)

Claim.—In an animal trap of the class described the combination with a cage of a vestibule or passage way, having inclined end walls, openings formed in said end walls, pivoted drop doors adapted to close said openings, pivoted floor plates arranged

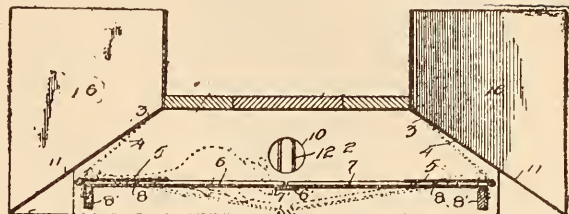

in said passage way, the inner end of which are formed with interlocking fingers, counterbalancing weights fixed to the outer ends of said floor plates, said outer ends being adapted to close said pivoted drop doors by weight of an animal upon the inner end of the same, stop walls and flaring wings arranged adjacent to the openings in said passage way, whereby the course of an animal is directed to said openings, a door or opening, communicating between said passage way and said cage, a downwardly inclined guideway extending from said door to the floor of said cage, and a drop door for closing said door and guideway.

726,140.—Animal Trap. John Campbell, Sr., Webster, N. Y. Filed July 15, 1902. Serial No. 115,708.

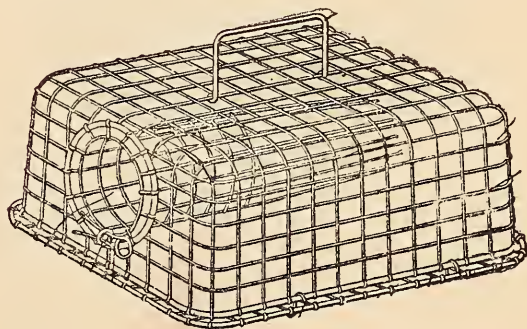

Claim.—1. A trap comprising a body, a bottom, and an entrance chute, the lower terminals of the opposite sides of the body having loop devices loosely held thereby and adapted to be passed through meshes of the bottom, and removable keys passed through the loop devices of the body and disposed against under sides of the bottom; also through a portion of the body and arranged against the outer ends of the chute, whereby the several parts of the trap may be quickly assembled or disassociated.

723,100.—Animal Trap. James P. White, Mattoon, Ill. Filed June 27, 1902. Serial No. 113,490. (No model.)

Claim.—In an animal trap, the combination of a box-like structure having one

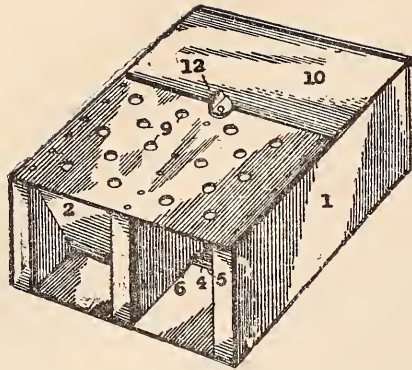

open side, a gate pivoted at the top and across said opening adapted to swing upwardly against the top of the box and to fall by gravity, a latch-plate pivoted to the box at an intermediate point near the bottom thereof, a stop for limiting the movement of the latch-plate, a latch secured to the latch-plate and adapted to engage the free end of the gate when the latch-plate is swung from the floor of the trap to the limit of movement defined by the stop.

721,407.—Animal Trap. Wilhelm Wilhelms, Bruning, Neb. Filed September 29, 1902. Serial No. 125,245. (No model.)

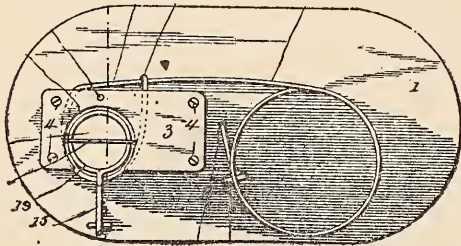

Claim.—1. An animal trap comprising a base with an opening, a spring-actuated choking loop movable thereover and a trigger disposed at right angles to said loop to engage the same.

2. A spring-actuated choking loop movable thereover and a trigger disposed at right angles to said loop to engage the same, and having a looped portion.

3. A trigger disposed at right angles to said loop to engage the same, and having a looped portion provided with a cross bar.

719,544.—Animal Trap. Pardon A. Whitney, Southington, Conn. Filed November 28, 1902. Serial No. 133,149. (No model.)

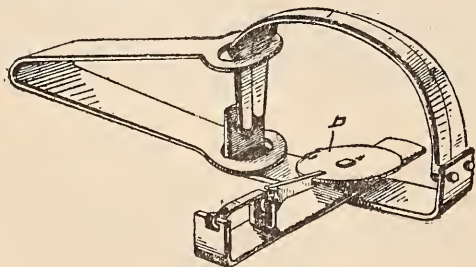

Claim.—1. In a trap of the class specified the combination with the base, the spring, and the latch, of jaws pivoted at each end in the base, one of said jaws being pivoted in a lower plane than the other jaw.

2. The combination with the base, the spring and the latch, of jaws pivoted in the base, one of said jaws being pivoted in a lower plane than the other at the spring end of the base.

726,350.—Animal Trap. Samuel Robinson, Monmouth, Ill. Filed December 27, 1897. Serial No. 663,546.

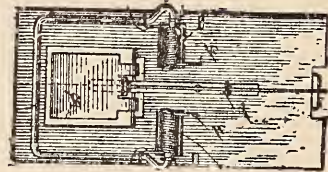

Claim.—1. The combination of a base, a spring-actuated clamping jaw, a trigger located at the front of the base and provided with a hook, and a latch pivotally secured at the rear end of the base and provided with a slot to receive the jaw, the toe of said latch extending forward in position to engage the hook of the trigger.

#### IN THE PORT TOWNSEND DISTRICT.

On previous trips up the Straits of San Juan and Puget sound I had admired the glorious view of the snow-topped Olympic mountains. Being told they were full of fish and game and but little known, I determined to have a try at them before those interesting conditions were changed.

After exchanging a few letters on the subject with Munro Wyckoff, game warden of Port Townsend district, I set out for that place with my usual outfit, relying on obtaining special articles, horses and supplies there. In that I was not disappointed, and finding Mr. Wyckoff familiar with the mountains, I secured his services as guide, with his brother, George, to take care of camp. Another brother, Lum, had recently been appointed ranger on the huge Government reserve, which comprises the central and best part of the Olympics, and I had the benefit of his experience as well.

We decided to go in with pack horses as far as possible and establish a central permanent camp from which to foray through the country. The open season on grouse begins August 15; on elk, September 1, and on deer, September 15. Owing to the frightful condition of the trail we made an early start and were 2 weeks going over ground which we covered in 2 days on our return. The winds and avalanches of winter had torn down and interlaced great trees by hundreds along the narrow canyon of the Big Quilicene river by which

we traveled, and it was necessary to send ahead men with saws and axes to cut a way through.

The forest and undergrowth were dense, almost obscuring the sun. Black bear and grouse were numerous and the river was full of delicious trout. On reaching the summit of the divide between Quilicene and Dungeness rivers, at an altitude of 6,000 feet, the country grew more open, with good feed for the horses, and snow on the peaks and sheltered spots. Deer were abundant. In an hour's stroll our first morning in camp I counted 10, the hills being fairly cut up by game trails. Bear and cougar sign were numerous, but these animals are too nocturnal in their habits to make hunting them a pleasure, though we saw several and shot a few. Near the salt licks the carcasses of fawns with torn throats gave evidence of the cougar's work.

The hot days brought into life myriads of exceedingly fierce flies and mosquitoes, making it necessary to wear mosquito hats when in camp, but the chilly nights gave respite from them and ensured good rest on luxurious beds of balsam fir boughs. We made our camp near a huge snow bank in which we refrigerated our meat and perishable supplies. Wild berries and flowers grew in profusion. Delicious soft, cold water was in abundance, forming lovely cascades and rills in every little canyon.

Our permanent camp was on a shoulder of Mount Constance, midway between the summit and the East fork of Dungeness river, amid particularly grand scenery. A little climb morning or evening to the ridges would be amply repaid by sunrise or sunset effects on the clouds and snow-clad peaks simply indescribable. Mounts Olympus and Constance are the highest points in this range; farther off could be seen the blue sound and straits, with Mount Baker and the Cascade range for a background.

In little secluded valleys, reached on foot, were bands of elk, often 50 or more, but we let them alone as it is almost impossible to pack out a head or a quarter of meat from such a country. It is no trick at all to bag deer, some of the bucks being large, with grand heads; but the job of getting them to camp often makes the hunter wish he had missed his shot.

An interesting animal thereabouts is the whistling marmot, a sort of huge prairie dog weighing 10 to 25 pounds. They are numerous and tame, and make hay like a farmer, cutting, drying and storing it. The Indians and some prospectors claim they are good eating, but most people seem prejudiced against them.

These mountains are full of gold, silver,

copper and iron, but the formation is so broken and travel so difficult that but few seek the prizes that are undoubtedly there.

All the rivers, Docewallips, Quilicene, Dungeness, Elwah and Solduc, and Quinault and Crescent lakes are full of trout, from the tiny brook species to the giant Beardsley, including the rainbow, cutthroat and Dolly Varden. The bays along the sound afford the finest salmon trolling on the coast. Grouse and Chinese pheasants are numerous and are found in the open stubble fields. Some way should be devised to make their presence remunerative to the farmer. His grain suffers from the birds and his stock is frequently riddled by irresponsible shooters. Hence it is not strange that he prefers to see the birds destroyed rather than protected.

Herbert Earlscliffe, Santa Barbara, Cal.

#### HUNTING DEER IN MICHIGAN.

Time: November 8th to 20th, 1899. Place: Schoolcraft county, Michigan. Party: Fisher, Hyde, Gleason, Mason, Selous, Hillman, I and Bishop, the cook, whom we nicknamed Rosie.

We left the train at a point where the railroad passes close to a bend of Indian river. Willing hands were soon at work dragging boxes and tents to the bank, using a toboggan and 4 man team. Rosie, Fisher and I were detailed to put up the tent, while the team returned for another load. We sat our guns near and were busy at work, when suddenly we heard the bark of a dog, followed by cracking of brush. Then out jumped a buck, which ran up the steep bank on the opposite side of the river. We each had but one load in our guns. Rosie fired first and missed; then Fisher, another miss. By that time the buck had reached the top of the hill, only 15 rods from our tent, and instead of disappearing, as we had expected, he stopped, turned his heavily antlered head and calmly looked down on us, much more calmly than we looked at him. You are wondering what I was doing all that time? So were Rosie and Fisher.

I use as my favorite deer gun my 12 gauge Remington hammerless, with a .45.90 rifle barrel inserted in one barrel. Previous to that time I had used the rifle in the left barrel and buckshot in the right, which was cylinder bore; but owing to my adoption of a new plan of loading buckshot for choke bore guns, I had changed the rifle to the right barrel. As the deer stopped, I took deliberate aim and pulled. No report. I broke open the gun, turned the shell and tried again. Still no report, for, of course, I had been pulling the wrong trigger, snapping the empty barrel which formerly held the rifle. After waiting a moment the

buck lumbered over the hill and out of sight forever.

Our tent was up and everything in good order before night. We had agreed that the man who killed the first deer should be chief of the camp, consequently every man was off early for the hunt, taking different directions. I crossed a stream and went West across a chopping into a large tract of hard wood. There was no snow, but I could see plenty of fresh signs. At a little after 8 o'clock I jumped a spike horn buck, which disappeared over a knoll after the first jump. The sound of his running ceased, and I knew he had stopped, as I could have seen him if he had run far, owing to higher ground that encircled us. I waited at least 5 minutes before I heard him. He had taken his back track and walked right back to the top of the knoll to see what had become of me. That time I pulled the right barrel and sent a 45 bullet into his breast, through his heart, and out at the fourth rib. He ducked his head, dropped his tail and ran, crazy like, but fast, about 20 rods, then went down. Had I not been sure of him I could have stopped him with the buck-shot. This proved the only deer shot that day, so my right to be chief of camp was not disputed.

The next day Fisher shot a big buck and a doe. After hanging them up he started down a logging road for camp, with his buck head on his back. Mason and I, who had come to him after his shooting, also started for camp, but through the woods parallel with the road. We had not gone  $\frac{1}{2}$  mile before Mason jumped a whopping big buck, but on account of the underbrush he could not get a shot. The buck ran straight to Fischer, who got up on a log when he heard him coming and put a bullet through his neck, killing him instantly. Either of these bucks would weigh nearly, if not quite, 200 pounds. Strange as it may seem, Fisher got no more deer after that day.

Owing to the fact that we had no snow, something unusual for November in the Upper Peninsula, our party of 6 got only 9 deer, all bucks but one; but the fine weather made camping so pleasant that we all agreed it fully made up for the absence of snow.

One of our party was no other than Percy Selous, who often contributed to *RECREATION*. He was a hunter and traveler of wide experience, an accomplished artist, naturalist, taxidermist, master of many languages, and, better still, a good fellow. We had a great joke on him one day. He was sitting on a chest in front of the tent, after a fruitless chase, and had been saying he was afraid he would not get a chance at a deer. Just then a mighty buck jumped with a splash into the river

from the thick cover on the opposite side and ran down stream, not 30 feet from Selous. His gun was in the tent. He called to Hillman and Mason, who were in the tent, to bring a gun quick. They did so, and fired several shots at the buck as he plunged about in the water, making for cover again. How we did roast Selous, only to hear him mutter, "Deuced hard luck! Beastly luck!"

E. A. Kemp, Greenville, Mich.

#### A BUFFALO HUNT.

In August, 1883, I was working for a cattle outfit, which employed about 40 men. We had just come off the spring roundup, where we had been for many weeks working about 22 hours a day and we had only recently caught up in our communication with the Land of Nod. It was not many days until the once tired and worn out cowboy was thirsting for some excitement, and after a few fights between some of the boys over cards, several shooting scraps, in which, fortunately, none were killed, I was informed by the horse wrangler that while riding in a certain flat he had seen a large buffalo bull. There was little need of his urging me to accompany him on a buffalo hunt on foot, for our 300 cow ponies were out on the range recuperating, preparatory to the calf and beef roundup, which was to begin in a few days. Although unusual to hunt buffalo on foot, we were of that age when "any old way" went, and being expert pistol shots, we had no fear. Each of us obtained Evans rifles and with Colt's 45 caliber revolvers, we went out. The buffalo was lying down in an uncultivated meadow. To his left, extending in a semi-circle was a dry creek, whose banks were 25 feet high. Up this bank my companion and I crawled and crept along some distance toward his lordship, until we had a good opportunity to open fire. He was then 150 yards away. We agreed to fire at the same time. Had we used our pistols we might have succeeded, but we chose the rifles, about which we knew little. After aiming steadily at his heart, we both shot simultaneously. His lordship arose, majestically, looked about, shook his shaggy head, and as the smoke directed his attention to his pursuers, he came toward us.

Keeping our eyes on this mighty beast, we at once attempted to manipulate the levers of our guns. Mine, curious to say, stuck; try as I might, I could not get another cartridge in and although I would not admit it, I seemed to be possessed of that peculiar feeling known to persons realizing they are in a tight place. The buffalo ran 150 yards to where we were standing. My companion went to the right, I to the left, each hoping the buffalo



would pursue the other fellow. Unfortunately for me I had in my right hip pocket a red cotton handkerchief, part of which protruded, and the bull singled me out as the person who had caused the pains in his side, for both bullets struck him, but too far back to produce instant death, and infuriated as he then was he came after me. I dropped the gun and although strapped around me was "old faithful" never once did I think to draw it and shoot his eyes out, as I could have done on other occasions. The "hot path" was all that occurred to me then, and I ran as I never have run since, to the steep embankment. When I reached it my courage failed me; I preferred to be gored to death rather than jump 25 feet. In my quandary I continued to run and every second the bull was gaining on me. Already I could feel his hot breath on the back of my neck, but when in the act of jumping to the apparently bottomless pit, I heard a shot to my right, a groan just behind me and the bull sank dead in his tracks, my companion having had time to get his second wind.

After helping ourselves to some tenderloin steak and some of the shaggy mane for pillows for our beds, we retraced our steps to the ranch. My companion ever afterward asserted that he had more nerve, was the better marksman and hunter, and was not in the least frightened after the bull got us in a corner; I was, however, too grateful to him for the timely shot, to claim any credit in the escapade.

Many years have passed since then, and I am still a hunter, having pursued all kinds of large game; yet the incident related is vivid in my memory.

V. H. Miller, Cripple Creek, Colo.

#### A QUIET STALK.

I have for the last 2 years been a constant reader of RECREATION and like the stand you take in regard to game hogs. I love to hunt large game, but prefer to stalk it and alone, matching my woodcraft against the cunning of the game. I have never used hounds and never shall use them; it looks to me like taking an unfair advantage.

In '77, when but 18 years old, I was a cowboy in Wyoming. Antelope and deer were abundant on the plains and elk and bighorn in the mountains. Every stream was full of trout. I was at what was once Millersville, at the confluence of Smith's and Black's fork rivers, 16 miles Northeast of Fort Bridges. Millersville was formerly a station of the overland pony express, but at that time it contained only 2 old log cabins and a log stable. An old-timer named Charles Bates and I were the only inhabitants.

One morning, while riding down Black's fork, I saw a deer in the stream. The side of the river I was riding on was rocky and hilly, covered only with sage brush. The other side was a level bottom and, in the bend of the stream, was a thicket of willows and cottonwoods about 400 yards long and 10 to 30 yards wide. I carried an old Sharps 50 caliber carbine, with front sight made of half an old copper cent. It was a good gun; I never had a better.

The deer saw me as soon as I saw him, and slowly walked out and into the thicket. I could have shot him while he stood in the water, but did not. I concluded to get him later, to stalk him and give him a show for his life. I knew he would stay in that cover during the day, if not disturbed.

At 3 that afternoon, taking an old pack horse, I was again on the hilly side of the thicket. I tied the horses to a sage brush, waded the stream, and began a careful stalking of the willows, most of the time on my hands and knees. I had covered nearly  $\frac{3}{4}$  of the ground without finding the deer. The willows were so thick I could hardly see 10 yards and in some places I could not stand upright. In front of me lay a dead cottonwood trunk nearly  $2\frac{1}{2}$  feet in diameter. I carefully peered over it and ahead, but could see no deer. I placed one hand on the trunk, then the other that held the gun, and was just raising my body up on the trunk, when something jumped up, not 12 inches away. It was my buck. I could have caught him by the horns as he raised his head, for the surprise was mutual, but in an instant he was up and going. I sprang up to shoot, but bumped my head on an overhanging limb, nearly breaking my neck and sending me back to earth. Before I could get up again the deer was out of sight.

I felt certain he would cross the stream where it was narrow and shallow at the lower end of the cover and make for the rough country on the other side. To think was to act. Being only about 10 feet from the bank I at once jumped into the water, which was there waist deep. The buck was where I expected to see him. He cleared the water at one bound, but fell dead on the farther shore, a bullet from my old Sharp's breaking his backbone. I dressed him, pulled him across the water and started after the horses.

I walked on the prairie side of the thicket, leaving my rifle with the deer. On my way another deer jumped up just at the edge of the willows and away he went. While stalking the first deer I must have crawled within 20 feet of the second one without disturbing him. Even the report of my rifle, not 200 yards away, had not caused him to leave the brush.

Frank Holz, Kansas City, Mo.

## WEST OF THE ROCKIES.

Since boyhood I have been a great lover of hunting and fishing. Have studied the habits of fishes and game, from the rabbit and quail of Ohio and Kentucky to the elk, deer, and mountain trout of the Rockies. In 1893 I traveled all through the National Park country, and had one of the best times of my life. We shot all the chickens we could use, from the wagon, and if it had not been out of season we could have done likewise with elk and deer. At every camp we caught all the trout we wanted, within 100 yards.

What a difference in the same country now! Last November Lieutenant Farrar, U.S.A., Charles and James Reilly, D. C. McGinty, I. M. Higley, Fred Kempton and I went to St. Anthony, Idaho; secured 3 guides, 2 wagons, one bobsled and 7 horses and went into that same country to get an elk before they should become extinct. We were almost snowed in; were lost 2 or 3 times, and did not see any game whatever, except a few grouse. I never fired my gun on the trip. We were at the Southwest corner of the National Park, and followed along the blazed line of the park North and East several miles.

The sheep is the greatest enemy of the game, and incidentally of the outdoor sportsman. We can not make Eastern men, except those who come and see for themselves, realize the wholesale destruction of the ranges by sheep. After a range has had sheep on it one year that settles the game proposition for at least 5 years. Game will not stay where sheep have been, and there are few places in this Western country, that have not been sheeped to death. The National Park is about the only place left. The game will leave this country in the near future, and it will go North; because in a few years there will be no range in the South. The average Eastern man would not believe sheep could be run in such brushy, rugged places as they are unless he saw the sheep or the effects of them. The effect is plainly seen several years after the sheep have once been over a range. It is wonderful how the herders manage their flocks in such places. They take sheep any place a man can go. It is a small expense to the sheep owner to run his sheep. Two herders can take care of 5,000 to 6,000 head. They get about \$30 each a month, and the owner can lose 50 per cent. of his flock each year and still come out a winner, with the privileges he has.

We hear of the wonderful abundance of game in the Jackson Hole country, but what does it cost to get a chance at it? You have to pay a license of \$40 to the State of Wyoming; and each man in the party must have a guide, at \$5 a day and

board. If the present method is continued, in 10 years the elk will be like the buffalo, we will see them in shows, parks, and zoological gardens.

Chas. E. Wood, Salt Lake, Utah.

## TWO GOOD SAMARITANS.

Here is a letter written by a 15 year old boy to his father in this city:

Inlet, N. Y.

DEAR FATHER:

Gerald and I have turned animal doctors. This is the way it came about.

Grandma wanted to go on top of Nipple-top mountain and I had to guide her. Gerald went with us. We were near the top when we heard a noise in the bushes. We looked and there was a deer struggling to get away. He could not use his hind legs at all and we walked right up to him; a splendid big buck. He had a small wound in the middle of his back, but it was not from a bullet. Then we looked back about 100 feet and saw where he had been lying under a dead tree and a big branch with a little spike, or knot, on it had fallen and hit him right in the back, paralyzing his hind legs. The wound only bled a few drops. We saw he could not live, as he would starve and he could not drag himself, either; so Gerald went back to get a man and an axe, thinking we could make a stretcher and carry the deer to Kennell's barn. When Gerald reached home they told him we could not do that, as it is against the law to take a live deer from the woods. There ought to be exceptions to such a law.

All we could do was to take the deer some hay and grain and pick ferns and put them before him. That night it rained furiously. The next day, Monday, we put on rubber coats and took a bag of hay and grain and went out to the deer again. When we got there we found him in a foot of water, where he had been all night. There was not much life in him then, but we dragged him about 50 feet, to a place where the water would drain off. There we made him a bed of ferns and hay, rubbed off from him all the water we could with our hands, and ripped open the bag and tied it on him.

When we were doing this the deer looked on and you could see how he appreciated it. He did not offer to harm us in any way, any more than a dog would. The deer will not eat anything and I fear he will die in spite of all we can do. If we could take him in a warm barn, I know he would live. I tried to call up Ned Ball, the game protector, but can not get him. We are going up again to-day, to make a roof over the deer, out of a bark pile that is near. It is not raining to-day, but looks

as if it was going to. In my next letter I hope I can tell you the deer is alive.

Your loving son,

Clarence.

#### MORE THAN WE EXPECTED.

In the early days in Northern Michigan, from Grand Rapids to the Straits of Mackinac, was a dense forest. It was then I engaged in hunting, trapping and fishing. I worked through the summer, and in the fall took my traps, gun, and a few camp utensils, a small supply of provisions, and started North for the season's hunting and trapping. I made a shanty of hemlock bark, covered with hemlock boughs, and in one end, with blue beech sticks and clay I made a little fireplace, which answered for both cooking and heating. In the other end of the shanty I made a bunk of hemlock boughs and marsh grass. This was my home for the season, and sometimes for several seasons. Those were the most enjoyable days of my life, as game was abundant. One fall, about 1874, in Osceola county, Marve Anton, Frank Buck and I got off the train at Leroy, and with our luggage on our backs, followed a blazed trail through the woods to Rose lake. There we built our hunting shanty and put everything into first class shape for the season's work. Several days were spent in fishing and duck shooting, as it was still early in the season and the weather warm. We found acorns abundant. There was one oak ridge 2 miles from camp where deer were working, so I proposed going up there at night and getting one. My chums were somewhat timid of the screeching owls and preferred daylight, so I got up in the morning about 2.30, took a lunch in my pocket, dressed warm and started for the ridge, leaving word with the boys that if they heard 3 shots in succession, to come at once, as I might need help. I reached the place selected and sat down under a red oak tree. Everything was quiet, but, as I supposed, the birds were getting uneasy in the tree above, for pieces of bark fell sometimes; but I could hear a deer a short distance away, so I did not notice the work overhead. I could see the glitter of a big buck's horns in the moonlight, and waited for him to come close. As I sat there a piece of falling bark nearly knocked my hat off. I looked up slowly, not to attract attention, and saw, on a large limb, a huge black bear. The deer forgotten, I bounded away from the tree. I had a double barrel muzzle loading rifle. Cocking it, I drew a bead on the bear's eye as best I could in the moonlight and fired. Down came the bear, so, loading, I fired both barrels to call the boys. When they came they were greatly sur-

prised to see such a large black bear instead of the deer.

S. R. Harris, Grand Haven, Mich.

#### A PLEA FOR THE SMALL GAME.

All around us we see the most wanton destruction of those animals and birds which add beauty, music and interest to every bit of woodland, swamp and meadow.

The rifleman desiring practice, the small boy with his 22, the farmer who associates every animal and bird with damage to his crops, and the city man who, having a holiday, goes out to "kill something," are slowly but surely exterminating wild life.

If these people could only be induced to lay aside their guns and go to the woods with telescope and camera and a desire for intimate acquaintance with the denizens of forest and swamp, how much more interest they would find in life! How much knowledge of scientific worth they would acquire!

The rifleman would then shoot only at vermin, the small boy would grow up a naturalist, the farmer would learn how few creatures really injure his crops and how many protect them, and the city man would have photos of real interest to remind him of days afield.

The average farmer knows little or nothing of the wild creatures he sees every day. If he sees a woodpecker in his orchard, he remarks, "there's that darned woodpecker peekin' holes in my trees," and goes for his gun, never thinking of the little borer drilling into his tree's vitals, on which the bird desires to make its breakfast.

If he finds a skunk in his fields he shoots the "pesky brute" at once for fear some night it might come near his mongrel fowls, never dreaming that the skunk is ridding his fields of insects. Better build a skunk-proof hen-house and let the animal continue its good work.

Most people regard all hawks as fair marks, calling all hen-hawks, whereas there are but 2 hen-hawks among all the common species; the Cooper's and the sharp shinned. The others do an immense amount of good by destroying insects and vermin. A safe test is to see if they visit the hen-house.

Some say "shoot the red squirrels, they eat birds' eggs." Didn't red squirrels eat birds' eggs before man came on the scene? Yet the number of birds did not diminish. No! rather leave the red squirrels alone. Man has upset the balance of nature enough already.

If instead of shooting every animal committing a real or imaginary offense against their property men would weigh their good work against their crimes, and only fire when the latter overbalanced the former, a host of beneficial and neutral creatures would be spared.

If people would only study more and kill less, wild life would soon abound about us and we should not leave to our successors deserted woods, voiceless meadows, and swamps whose deathly stillness would be only broken by the croaking of the dismal frog.—A. B. K., in the Cornwall, Ont., Standard.

#### AN ENCOUNTER WITH A LYNX.

I have just returned from a hunting trip to the Boston mountains in Northern Arkansas. There were 4 in our party, and, excepting one untoward incident, we had a delightful time. The mountains are high and well watered, and game is abundant. The region is, however, difficult to reach. We left the railroad at West Plains, Mo., and took a stage from there to the Mountain House, 60 miles distant. Thence we drove 40 miles to our

destination, over as rough a road as can be found this side of the Rockies.

The afternoon of our second day in camp I took my rifle and set out alone to see what I could find. After climbing steep mountains and scrambling over rocks for several hours, I came across a bunch of 9 turkeys. I succeeded in killing one, and then, it being almost dark, I started back. When nearing camp something struck me a terrific blow on the shoulder, knocking me down. When I regained my feet, I found myself face to face with a lynx, or bob cat, as it is called in the South. I fired at him and missed. He made a dash for me while I was trying to force another cartridge into the breech. The shell stuck and put my gun temporarily out of commission. Using the weapon as a club I soon drove the cat up a tree, but not before the brute had slit the legs of my trousers and torn most of the flesh from the back of my left hand. I managed to get a shell into my gun, and, after 3 unsuccessful attempts, killed the lynx.

I presume the animal was really after the turkey when he made his first leap, but he certainly made things interesting for me awhile. Fortunately my hand is not crippled, but it will be badly scarred as long as I live.

Dr. J. W. Bell, Dayton, O.

This story of an encounter with a lynx is a most remarkable one. For many years I have refused to believe any of the numerous newspaper yarns about these animals as well as panthers, black bears and wolves attacking people. In fact, I have investigated several such reports and have been able to ascertain definitely that they were entirely false. This story, however, is different. It has the ring of truth in it, and I can not doubt it. In a subsequent letter Dr. Bell gives the names of a number of persons in Indiana and Ohio who will vouch for his veracity. Dr. Albert Garver, of Mountain Home, Ark., was with Dr. Bell's party and dressed the wounded hand.—EDITOR.

#### IN THE EARLY DAYS.

Away back in the 70's much of the traffic of the Northwest was carried on by steamboats which drew their supply of fuel from wood yards strung along the river. The Northwest at that time was full of hostile Indians, so a man, to run a woodyard, needed to be brave and cool. It was a life of constant danger.

Mike Duvall was such a man. He ran a wood yard on the North bank of the Missouri between Cow island and Fort Carrol. The last boat of the season had gone down and Mike and his men were supplied for

the winter except for meat. No one then ever thought of buying meat beyond bacon now and then as a change, or a slice for the beans; buffalo, deer, elk and antelope were abundant.

One afternoon Mike asked the temporary cook how much meat he had and was told there was only one saddle of venison left. This was urgent, so Mike shouldered his Winchester 45-75 and paddled across the river, heading for the sources of some creeks pouring into the river farther away. This was a favorite ground for mule deer.

Just as he got to the head of a draw he discovered a buffalo cow feeding near the head of another coulee, and he saw that by going back a little he could creep close to her. Stealthily he crawled along till within 100 yards and fired. She ran as if untouched for 50 yards, then rolled over. Mike walked over to cut her throat and was just bending over her when ping! went a bullet so close that he could feel its wind. He fell as if shot and instantly the report reached him from a clump of bushes 150 yards away. Mike lay motionless a long time and was at last rewarded by seeing his enemy crawling to him over the hill and within 60 yards. As the Indian saw no signs of life near the cow he seemed to gather courage, and when within 50 yards Mike sprang up, as he says, to see how the spalpeen "would like the luk o' my ghost." The Indian was so startled that he discharged his weapon into the ground "for-ninst" himself. Before the poor devil had time to do anything old "Meat in the Pot" spoke and there was one more good Indian.

Mike dragged the good Indian into a washout, took his scalp and then cutting off as much of the cow as he could carry, went back for help for the rest. Being asked as to the scalp he replied, "Be jabers, I kilt some carrion as well as the cow."

M. F. Hackett, Lakeview, Mont.

#### THE HOG RECORD BEATEN.

Havre de Grace, Md.—Duck shooting has been poor on the Susquehanna flats this spring. Yesterday, however, Capt. William I. Poplar and his brother killed and picked up 122 ducks within 30 or 40 minutes. Of these, 82 were canvasbacks. This is a phenomenal shooting record, but the men had their chance and improved it. The ducks fairly swarmed around them while the men kept their boxes in position.—Baltimore Record.

I wrote Captain Poplar asking as to the truth of this report and he replied:

My brother, Jesse D. Poplar, and I set out at daylight and were not able to shoot more than an hour when the tide and current made us take up. The ducks darted faster than we could load our guns and we killed them when they came. We gathered 122, of which 82 were canvasbacks. It was the greatest hour's shooting we ever had. The ducks flew and darted well.

We used 2 single boxes about 750 decoys. That broke the record of any shooting on the flats, especially on canvasbacks.

Capt. William H. Poplar, Havre de Grace, Md.

The dispatch says:

"Duck shooting has been poor on the Susquehanna flats this spring." Then the reporter proceeds to laud a pair of bristly brutes, who killed 122 ducks in 40 minutes.

It is because such slaughter as these Poplar porkers committed has been going on for the past 20 years that duck shooting is now so poor everywhere. Occasionally the ducks bunch in here and there, and if a shooter happens to be present at the time, he gets good shooting. All gentlemen know when to quit, even in such rare cases; but these Poplars did not. They will probably continue to hang around the flats, as long as they live and to eke out a miserable existence by occasionally getting \$5 or \$10 from some sportsmen who would like to kill a few ducks. Furthermore this Poplar type of swine will occasionally get a flight of ducks, murder them, and, if possible, sell them.

This slaughter was committed in the spring, too, when the birds were on their way to their nesting grounds.

The only way we can ever hope to put these disreputable brutes out of business is to stop spring shooting, and to stop the sale of game.

Captain Poplar's number on the game hog list is 891 and Jesse D. Poplar's is 892.

—EDITOR.

#### AMONG THE DUCKS.

Twin lakes are situated 5 miles North of Rockwell City, Iowa. They are beautiful bodies of water separated by a ridge 30 rods wide. The North lake is  $\frac{1}{2}$  mile wide and 3 miles long. The South lake is about one square mile in extent. These lakes are on a large prairie and are partly surrounded by small trees. To the Northwest extends a large marsh called Hell's slough. Lakes and marshes are surrounded by immense grain fields.

By September 1, when the open season begins, teal are abundant and the first day or 2 any one with a gun can get ducks; but teal are no fools, and soon even expert shots fail to bring in large bags. Later come spoonbills, widgeons and other small ducks. Still later bluebills, with a few canvasbacks and mallards; but it is during the last of October and the first half of November that the canvasback and mallard hold high carnival on these lakes.

Some of our local shooters and a few visitors had royal sport last fall. About November 1, Frank Owens and Peck Mead, 2 local sports and expert wing shots, took

a 2 days' shoot on South lake, killing over 200 ducks. They are royal good fellows as well as good shots, and know the ways of the birds.

Some sportsmen may cry game hog, but if they had seen the boys shoot, standing in their boats on the lake, the wind blowing a gale and the waves rolling, they would have been as ready to cheer as we were.

D. C. Nowels, Rockwell, Ia.

If I were you I would not waste time apologizing for any man who slaughters game. It is the most utterly hopeless task you could possibly undertake in this age of the world. When you tell about 2 men killing over 200 ducks in 2 days, you may as well submit their case to the jury of public opinion without comment, for no amount of argument in their favor could conceal their bristles. These men may be "sports," as you term them, but they are not sportsmen, no matter how rough the weather was, or how hard the porkers had to root to get their game.

Owens is game hog number 893 and Peck Mead is hog number 894.—EDITOR.

#### HOW THE BUFFALO DIED.

It was on the sandy waste of Colorado. The hot day was nearing its end. The sun, which had scorched the arid plain all day, cast its rays obliquely on it, tinging all objects with a brownish yellow hue. North, South and East spread the limitless desert; not a single mound or hillock relieved the tired eye. Toward the setting sun, and gleaming with ethereal beauty, Pike's Peak raised its 14,150 feet of awe-inspiring majesty to the heavens.

It was at the close of such a day that Leslie Winton, explorer and naturalist, spurred his tired pony toward a stream which he had selected as a favorable spot for the night's halt. As he approached the place he saw something which made him quicken his horse's pace. In a few minutes he arrived at his goal, and there, a few rods from the stream, stood a noble bull buffalo. Winton's first impulse was to shoot, but after a second glance he lowered his piece and intently observed every movement of the beast.

The bull was dying; the emaciated flanks, sprawling legs and lolling tongue proved it. Yet even in his sore strait he bore himself with a natural majesty which bespoke the king. The dull, lusterless eyes, shaggy neck and defiant poise of the head uphold the reputation of savage strength so characteristic of the buffalo, even in death.

In a few moments unmistakable signs of the end became apparent. Twice he fell on his knees and as often regained his feet. The third time, struggle as he would, he could not rise. He knelt there, then with one mighty bellow, breathing defiance to

all the world, the leader of many a herd, the victor of many a fierce encounter, fell on his side and died.

Slowly and thoughtfully Winton removed his sombrero in reverence for the brute king who had once reigned supreme over this wide expanse. Then, with a kind word and a pat, he urged his tired pony once more onward, while over that barren waste settled the shroud of night.

Carl A. Leasenfeld, New York City.

#### GOOD WORK IN THE PHILIPPINES.

When I was in the Philippines with an American rancher, I was out hunting, in the mountains of Banquet. We camped along the creek, and every day while sitting around camp, we saw natives passing along the trail with bulls loaded with nets, each native leading a bunch of dogs. Later in the day we heard the parties high in the hills, whooping and yelping, and dogs barking. We concluded that those natives were chasing deer into their nets. One night we were talking about game laws in the islands prohibiting the use of dogs and nets, and such other means of hunting deer. Mr. M., my friend, suggested going up in the hills the next day before the natives should pass and witnessing the hunt; and if we should get a chance, killing the dogs and destroying the nets. The next morning we were up early and picked a place so we could see 100 yards or so around us. In about 2 hours the leading dogs were a short distance from us. Mr. M. said to me,

"Take good aim and kill all the curs you can."

I was more anxious for the dogs to come, than if I had been waiting for the largest buck. We opened fire and succeeded in killing 3 dogs, and crippling 2 more; but I thought I should die laughing to see the curs stampede. Not another sound was heard from either natives or dogs. We went to the next hill, and ran right in their net but nothing was in it. Perhaps we saved a deer or a boar. After cutting the nets, we returned to camp, satisfied with the day's work.

John N. Bryan, Bakersfield, Cal.

Good! I wish every man who finds a dog running a deer, in this or any other country, would kill the dog; and some of the dog owners deserve killing, too.

—EDITOR.

#### ENRIGHT'S BEAR.

C. F.

Near the top of Merrit mountain, on the Idaho-Nevada State line, Mike Enright, who weighs 240 pounds and has fully as many friends, had driven his 4 little stakes and was doing his assessment work. He

usually rode to and from his claim, as it was some distance from his cabin.

One eventful day he took his Winchester across his saddle and started for his prospect, intending to do a little hunting on the way. Within easy walking distance of his claim he dismounted and picketed his horse with a goodly length of rope. Standing his rifle near, he rambled up the hill until he came face to face with a huge bear, evidently eating berries. Mike didn't ponder a second, but started down hill at his best gait, grasped his gun, vaulted into the saddle, and, digging his heels into the horse, started for home. He probably would have reached it in good season if he had not forgotten to pull up his picket pin. As it was, he continued his journey some little distance after the horse stopped.

When Mike opened his eyes there was no bear in sight, only his horse feeding close by, still fast to the rope, and the rifle 50 feet farther down the hill. He gathered himself together and started homeward, trying to remember how it all happened. Suddenly he saw, peering through the willows beside the trail, another bear. To prove to himself he was still a hunter he opened fire and made things smoke for a few seconds. Instead of the growl and tearing of brush he expected to hear came the awful bray of a burro which another prospector had staked in the brush for the night. It was badly wounded, but Mike nursed it back to health, and it may still be seen on the range with the wild horses, where it is known to the punchers as Enright's bear.

#### A TREE BEAR.

One morning, on going to a bear trap where I expected to catch a big grizzly, I found the trap and a good sized clog gone. It was no trouble to find the trail. Small trees had been torn out of the ground, dirt thrown about, and Cain raised generally. The bear had gone through a small opening, and, by marks in the light snow, I could see he had swung the clog clear around him, with only the end touching the ground.

I had just made up my mind for a long tramp trailing him, when I came on the trap and clog, with the little toe of his left forefoot in the trap. The bear had left on a slow walk and, I think, looking back over first one shoulder and then the other, and gritting his teeth. He was, no doubt, in a nasty temper, and would have jumped on anything he saw move.

I took the trap on the horse in front of me and started for camp. The grizzly had taken the same course, so I was on the lookout for him. I had not gone far before I saw, in a small opening, 100 yards away, my grizzly standing, with only his

body in sight. Reaching over carefully I set the trap on the ground and got off the horse. I pulled my rifle from the scabbard, took careful aim over the horse's back and fired. The bear never moved. I thought I would investigate before shooting any more. I found I had shot at the trunk of a tree, and hit it, too. The tree had been bent over while small, and was just the right height, size and color for a bear.

S. N. Leek, Jackson, Wyo.

#### ELK IN TWO-OCEAN PASS.

We had traveled 18 days by rail, wagon and pack train and for 8 days had hunted unsuccessfully. One of our party had, it is true, missed an easy shot at a bull elk, but that had been the extent of our luck. We had moved camp to Enos lake and, this particular morning, I was routed out of my comfortable spruce bough bed long before dawn, in order that we might be far from camp when daylight appeared.

We set out in a Southerly direction and after tramping a mile or so came on fresh tracks of a band of elk. We were about to follow them when the guide, Jimmie, saw, in the direction from whence the tracks came, one of those little parks so numerous in that country. He led the way to it. While we were ascending a slight elevation he whispered, "There he stands, head on. Take him where the light and dark colors meet." I could see only what seemed a dead bush, taller than its green neighbors, but was presently able to distinguish the head and shoulders of an elk standing 200 yards away. It was my first sight of big game and I took a good look at it along the barrel of my rifle. When satisfied with my observations I touched the trigger and became owner of a beautiful pair of antlers. The following day I killed another bull elk and saw others.

In the Two Ocean Pass country elk are exceedingly wild from constant persecution, thousands having been slaughtered in recent years merely for their teeth.

A. H. Nelson, Pittsburg, Pa.

#### HUNTING DEER IN THE SOUTH.

Day broke with a clear sky, calling all up for preparation. Guns were taken from their cases and hurriedly inspected, and every one rushed to the kitchen at the call of "Breakfast!"

Breakfast over, we started out for a buck. A mile and a half from camp we struck a trail in the thick swamp to the right of the road and the hunters scattered as the dogs gave tongue. In 10 minutes the baying of the pack in the distance told us that the game was roused and every one was on the alert. Every one covered his stand except one, who, being on his first visit, did not know where to find a

stand. After many fruitless endeavors to find one, he finally threw himself down, in utter disgust, and waited to hear some hunter's gun.

Suddenly looking up he saw a 4 pronged buck standing only 30 yards from him. Bang! into the face of the flyin' jib; but he scored a miss, shooting high. Four buckshot cut streaks down the astonished buck's back, and he halted directly across the road, offering a splendid broadside shot at 35 yards. This time the aim was better and the game dropped without a struggle.

A blast of the horn brought everybody hurriedly to the scene; the usual congratulations were extended.

J. S. Estill, Savannah, Ga.

#### CAME AFTER THE HOUNDS.

I left here October 18 for Animus river, where I joined Jim St. Claire and Bill Shute. We went to the Hermosa creek country after deer. Brice Patterson, of Silverton, got there first, with his hounds, and we found no deer, but most abundant signs of their recent presence. We also found signs of elk, but they, too, had gone. Hermosa creek is famous for trout, but we could find none. Whether or not Brice Patterson had chased them out of the water with his hounds, I can not say.

In despair we returned to the Animus river, and hunted deer, without success. They were too highly educated, and the ground was dry. I got 2 shots at a big timber line buck; one running, the other standing, at about 400 yards. Both went high. I made too much allowance for distance, and not enough for the great carrying power of my rifle. Two cowboys roped a large black bear near us, strung it out, and killed it by pounding its head with a rock. They estimated its weight at 450 pounds.

Two large mountain lions crossed the main road within a mile of this city, and within 200 yards of the village of San Maguel, in the middle of the day. They were seen by many, but no one had a gun. Eight or 10 deer, and several bear were killed near here last fall. Grouse were rather scarce.

C. M. Coleman, Telluride, Colo.

#### THANKSGIVING QUAILS.

Last Thanksgiving day I started out with my gun and 3 setters for an afternoon's sport. A friend and his little boy went along. In this locality we are not blessed with an abundance of game, but we wished to try our luck; so we harnessed a horse to a spring wagon and drove 3 miles to Brookville, tied the horse and set out. We

hunted until an hour before sunset without seeing a feather, although the dogs worked hard. As we were about to turn back, I chanced to look around and saw the dog standing as stiff as a tree in one corner of the field. When the birds rose we dropped 3. This, of course, put new life into us. The dogs retrieved their birds nicely and we started in pursuit of the scattered covey, which had settled in chestnut timber, bagging 5 more before dark.

At one time my friend was 400 or 500 yards from me when he flushed and killed a quail, firing both barrels. I saw a quail coming toward me. When it saw me it turned straight away and I fired. I could see I had killed it, but although I saw it turn over several times, and fall between 2 trees, the dogs failed to find it. While searching for my bird, the boy found it on the side of a large chestnut. In falling it struck the point of a projecting stick, which passed through the body and out of the back, holding it 10 feet above the ground.

Richard Hendrickson, Jr.,  
Sea Cliff, L. I.

#### IN SOUTHERN MONTANA.

In the fall of 1900 I fixed up a camping outfit and with my wife went to Big Sheep Creek basin, 20 miles distant. On the way we caught a nice mess of trout. Arrived in the basin, I took my shot gun and a few shells and bagged 6 sage chickens. The next day we merely fished a few minutes and bagged 3 more chickens. The third day we breakfasted early, and rode to Dead Man's lake, taking our bedding, to be prepared to remain over night if necessary. This little lake is one of the best for trout fishing in the Rocky mountains. While my wife fished I took my 30-30 Winchester and went to a good place for deer. I was out 3 or 4 hours before I saw something I took to be a deer. I looked through my telescope and counted 6. Working my way within 250 yards I lay down, took deliberate aim at a buck and fired. The rest of them were soon out of sight. I dressed my deer, a 3-pronged buck, and hung him up. At camp I found my wife had caught 9 2-pound trout. Then I saddled up the horses and brought in the buck. The next morning I shot another deer at the water's edge. Then we packed up and returned to our first camp.

John Patterson, Dell, Mont.

#### GAME NOTES.

I have been a regular reader of your glorious little magazine for several years. I take other sportsmen's magazines, but RECREATION is above them all. The way you roast the hogs amuses me. We have a few specimens here, but as our game laws are strict and well enforced, the swine

can not greatly injure our game. Prairie chickens, grouse, and quails are numerous. We also have excellent duck and goose shooting. I take much interest in game protection. It is the duty of every sportsman to do all he can to prevent game from being slaughtered. You are doing all you can and you have accomplished much. Keep the good work going and we will stay with you.

F. J. Brechan, Chamberlain, S. D.

I hand you a clipping from the Fort Wayne (Ind.) Journal. You will see that we do a little game protecting here. There is such a thing as being too late, but Volmerding was a little too soon. Game is scarce with us and needs all the protection we can give it.

H. D. Stokes, Fort Wayne, Ind.

Here is the clipping:

Henry Volmerding was out a day or 2 ago with his dog and gun, and fired one shot into a covey of quails. As far as he was able to tell he inflicted no damage on any of the birds. Deputy Game and Fish Warden R. D. Fleming heard of the matter and filed an affidavit in Justice Bullermann's court. Volmerding entered a plea of guilty. He was fined \$5 and costs, to which must be added \$20 that goes to the State, and all told, he was compelled to pay \$34 for his one shot.

The laws respecting game in force in the Northwest Territories now apply to the following Indians, in the bands and agencies:

Yellow Quill and Kinistino, at Touchwood hills.  
Cote, Key and Keeseehouse, at Pelly.  
James Smith and Cumberland, at Duck lake.  
Chippewyan, at Onion lake.

Alexander, Joseph and Paul, at Edmonton.  
William Twatt, Petequakey, Mistawasis, Ah-tah-ka-koop, Kenemotayo and Wah-pa-ton (Sioux), at Carlton.

Saddle Lake, Blue Quill, James Seenum and Moose Woods (Sioux), at Saddle lake.—Calgary, Alta., Herald.

The 29th of December a carrier pigeon came to me and has remained ever since. On each leg is a silver band, with inscription on one A. T. B., 22, 1899, and on the other 48, 1901. Can you give me any information so I can find the right owner?

Eli F. Cushman, Bethel, Me.

Lynxes and foxes are being brought in every day. G. C. Harrington caught a lynx, in his trap, measuring 3 feet 11 inches from tip of nose to tip of tail.

H. R. Grey, Danby, Vt.

There are a few grouse in the woods South of this place. Game laws are not enforced at all.

G. E. Spendley, Syracuse, N. Y.

Boast not, and the world knows not who you are; boast, and it despises you for what you are.



## FISH AND FISHING.

### ALMANAC FOR SALT WATER FISHERMEN.

The following will be found accurate and valuable for the vicinity of New York City:

Kingfish—Barb, Sea-Mink, Whiting. June to September. Haunts: The surf and deep channels of strong tide streams. Baits: Blood worms, shedder crabs and beach crustaceans. Time and tide: Flood, early morning.

Plaice—Fluke, Turbot, Flounder. May 15 to November 30. Haunts: The surf, mouth of tidal streams. Baits: Shedder crabs, killi-fish, sand laut. Time and tide: Ebb, daytime exclusively.

Spanish mackerel—Haunts: The open sea, July to September. Baits: Menhaden, trolling—metal and cedar squids.

Striped Bass—Rock Fish, Green Head. April to November. Haunts: The surf, bays, estuaries and tidal streams. Baits: Blood worms, shedder crabs, Calico crabs, small eels, menhaden. Time and tide. Night, half flood to flood, to half ebb.

The Drums, Red and Black. June to November. Haunts: The surf and mouths of large bays. Bait: Skinner crab. Time and tide: Day, flood.

Blackfish—Tautog, April to November. Haunts: Surf, vicinity of piling and old wrecks in bays. Baits: Sand worm, blood worm, shedder crabs, clams. Time and tide: Daytime, flood.

Lafayette—Spot, Goody, Cape May Goody. August to October. Haunts: Channels of tidal streams. Baits: Shedder crabs, sand worms, clams. Time and Tide: Day and night flood.

Croker—July to October. Haunts: Deep channels of bays. Baits: Shedder crabs, mussels. Time and tide: Day, flood.

Snapper—Young of Blue Fish. August to November. Haunts: Rivers and all tide ways. Baits: Spearing and menhaden; trolling pearl squid. Time and tide: Day, all tides.

Sheepshead—June to October. Haunts: Surf and bays, vicinity of old wrecks. Baits: Clams, mussels, shedder crabs. Time and tide: Day, flood only.

New England Whiting—Winter Weak-fish, Frost-fish. November to May. Haunts: The surf. Baits: Sand laut, spearing. Time and tide: Night, flood.

Hake—Ling. October to June. Haunts: Open sea surf, large bays. Baits: Clams, mussels, fish. Time and tide: Day and night, flood.

Weak-fish—Squeteague, Squit. June to October. Haunts: Surf, all tideways. Baits: Shedder crabs, surf mullet, menhaden, ledge mussels, sand laut, shrimp. Time and tide: Day and night, flood preferred.

Blue Fish—Horse Hackerel. June to November 1st. Haunts: Surf, open sea and large bays. Baits: Menhaden, surf mullet and trolling squid. Time and tide: Daytime; not affected by tides.

### MISSOURI NEEDS AROUSING.

I have been reading RECREATION 2 years and find you are after the game and fish hogs just right.

Jasper county, Missouri, is one of the best places on earth for fish, and fish hogs. Center creek, Spring river and Dry Fork are all good for bass, crappies, and other fishes, but there are so many fish hogs that all kinds of fishes are getting scarce; and the laws to protect them are not enforced. Bass are fished for with bait, and when they will not bite, in the winter, the hogs go after them with a gig. If the water is muddy, these swine set traps. In April when bass go on the nest,

they are shot or seined, and I do not see how any of them are left. There is a law to protect bass, but half the fine goes to the constable, and few of the fellows who do the shooting and seining have money to pay their fines; so Mr. Constable does not pay any attention to them. Last spring when the constable was told about some men who were seining bass under the dam, and one informant offered to go with him, the constable would not do it because there was no money for the officer in making an arrest. These fish hogs shoot 5 or 6 bass when they are nesting, carry them right through the town, and brag about it, and nobody says a word. It is the same with all other kinds of fishes. I see lots of bass under 6 inches sold in the restaurants here.

There are some white fellows here, and some niggers, that do nothing but fish. They sell everything they catch. There is a crowd at McDaniel's mill now and they will not leave there until the bass quit biting. There is another crowd at Oustott's lake. They use a trammel net.

There is also a crowd that has been fishing at Galesburg all winter, and they bring fish to market every week. They say the bass are biting well, but it has been cold for bass to bite, part of the time, and you can guess how these men got them.

Two of the worst enemies of fishes are poison and dynamite. A case of poisoning happened at Bower's mill. They must have killed a ton of fishes, for the bodies got to smelling so bad that the people had to haul them away and bury them.

About a year and a half ago, at McDaniel's mill, I saw a lot of buzzards and smelled a sickening smell; and for about a mile the river was full of dead fishes and turtles. The buzzards were eating them. Somebody had set off dynamite and killed everything.

Last spring someone put dynamite or poison into the mill race right here in town and killed lots of fishes, but nothing was said about it.

The dams are all high and there is no place for the fishes to get over, except at the one here, which is low and sloping. The one at the old McDaniel mill has a place fixed for fishes to get over, but it might as well be up the side of the court house for all the good it does the fishes. The water does not run over it more than once a year. I understand that there is no fishway at Baxter Springs, Waco, Galesburg, or at Forest mills, and that all the dams are high. I wish some of the fellows here would get up a club to protect the fishes; something like the gun club that

looks after the quails: If something is not done soon, we shall have no fishes left.

Gabe Thompson, Carthage, Mo.

#### A SLIP ON THE FLY.

I greatly enjoy going through piles of old magazines and papers that lie covered with dust in an old garret. In one of my recent searches I found a slip that may be of use to the casters of the fly. It was laid away carefully in the leaves of a magazine with no signature to tell who the author was. It was as follows:

"I have just seen an artificial fly made and used by the Indians of Kings river, in California, for fishing. It was given to one of our State fish commissioners by a gentleman who has pushed his travels through that unknown part of the country. There has been little if any communication between white people and these Indians, so the idea of taking fish with an artificial fly clearly originated with themselves. From what can be learned these Indians have used flies for many generations past; how many it would be difficult, if not impossible, to establish, but long enough in all probability to give them priority of manufacture over any of English or other civilized make.

"We are not indebted to the Indian for the artificial fly, for we discovered the utility of it without his aid; but for all that, it may now be safe to assume that he invented it and used it long before we did, either in England or here. To the Indian, then, should the credit of the invention of fly fishing be given, and to this tribe on Kings river. No other tribe on this continent, as far as I know, appears to have used flies for taking fish. The hook of the fly I have seen—the first and perhaps the only one ever possessed by a white man—is made out of a piece of iron wire. It has no barb, but the portion of the shank of the hook not covered by the fly, and down to the crook, is wound with a fibrous substance resembling flax, to prevent, in some degree, the fish from slipping or getting off when once hooked. Before the Indians got iron or iron wire to make the hook they made it from the tibia or shank bone of the deer, as being the hardest and closest grain of the bone. The fly, although a little roughly put together, is beautifully made, closely representing when cast on the water that which it is intended it should, the caterpillar. It is made from the hairs taken from the deer's hock, which possesses a scent. It is also sometimes made from the long hairs of the wart on the deer's leg; from which there is also a scent. It is generally supposed that the scent of the deer comes from between the hoof, but old deer hunters will tell you that it also comes from the wart. The

Indians say the fish like the smell, and water will not destroy or dissipate it. Here is an important fact for anglers and artificial fly makers. In tying, the hairs lie up the shaft of the hook, so that when the fly is thrown and drawn across up and down the stream the action of the water causes the hairs, of a reddish tint, to spread out. When the strain on the line slackens the hairs spring back, and the movement so produced, of opening and closing the hairs, gives to the fly the lifelike action and the appearance of a caterpillar.

"These Indians say that mountain trout will take this fly when they will not look at any other bait. The line is made from a fine fibrous plant which grows there, resembling what is called the milk plant, of which there are 3 known varieties on this continent. The line is as strong as the best silk one cast, with the advantage of being considerably lighter.

"The important fact is that the Indians of the West coast caught fish with an artificial fly probably long before such were known and used in England; also that those of the Indians are constructed on more scientific principles than those of European or other manufacture."

Edwin C. Hobson, Nashua, N. H.

#### TWO NEW REELS.

724,208.—Fishing Reel. Edward D. Rockwell, Bristol, Conn., assignor to Liberty Bell Company, Bristol, Conn., a corporation of Connecticut. Filed July 29, 1902. Serial No. 117,435. (No model.)

Claim.—1. The combination, with a fishing reel having a chambered spindle, of a gear loosely mounted on said spindle and provided with a recess having a wall eccentric to the axis thereof, said recess terminating in a shoulder; a device mounted in the spindle, and adapted automatically to engage the shoulder of the gear-recess when the spindle is rotated in one direction, and to be disengaged from said shoulder when the spindle is rotated in an opposite direction; and means for applying resistance to said gear.

2. A spindle having a bore at one of its ends; a roller mounted in said bore; a device sleeved on the bored end of the spindle and having a recess of greater amplitude than the spindle, said recess having a shoulder with which the roller is adapted to engage when the spindle is rotated by the running out of the line; and click and brake elements cooperating with said device, etc.

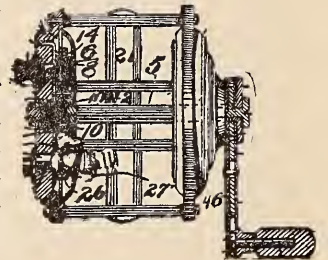

726,655.—Fishing Reel, John Dreiser, New York. Filed December 3, 1902. No. 133,691.

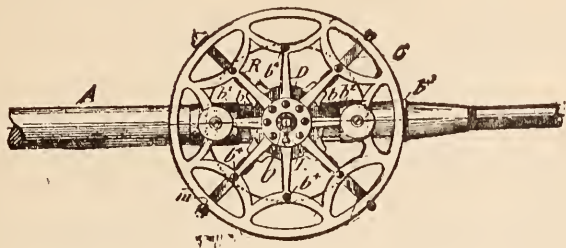

Claim.—1. The combination, with a concave plate, of a fishing reel provided with a spindle at right angles to the plate, of a disk attached to said concave plate and spindle, radial arms on said disk extending to the outer circumference of the reel, and pivoted and spring-actuated fingers at the outer ends of said radial arms and adapted to be moved transversely across the reel.

#### WITHIN SIGHT OF THE CAPITOL.

I enclose clipping which explains itself. It is generally believed among anglers hereabout that these acts of piracy went on all winter.

The fines for illegal fishing, amounting to \$138.13, which were assessed against William Baltzell, John Thomas, John W. Brown and William Lacey, were paid by the men involved, who pleaded guilty. By the terms of the law one-half of this sum goes to the policemen who made the arrest. The boat and net recovered by the officers have been ordered turned over to the fish firm of Neitzey & Ballenger, who were shown to be the real owners. The firm promised that the apparatus should not again be used in District waters.—Washington, D. C., Post.

Not only the Eastern branch, but Oxon run, a tributary of the Potomac, within the jurisdiction of the District of Columbia, is nightly seined; and it is the general opinion that the tidal basin is also hauled every night when there is no ice to prevent.

It would seem that this law breaking can be stopped, but no vigorous steps to that end have yet been taken. Our closed season brings some relief, as it lasts through April and May, during which time it is punishable by a heavy fine to have in possession in this District a bass of any character.

Last winter was an unusually open season. One day in the middle of February I counted 21 anglers on the North seawall of the tidal basin. They were catching big mouth bass. The fish were sluggish, but they took the bait.

Bass fishing about here last fall practically amounted to nothing, owing, no doubt, to the continued mild weather and the consequent high temperature of the water. We usually have some good sport

in October and November, but it failed us this year.

W. F. Dunn, Washington, D. C.

#### BASS IN MAINE.

Charlie and I left Boston the 31st of June and arrived in North Wayne, Maine, about 12 o'clock. That town is a 7 mile drive from Winthrop, the nearest station on the Bangor and Aroostook railroad. We got a boat and went to a lake about 2 miles from the Androscoggin river. At the lake we caught a can of live frogs and took up our position just outside a little neck of land through which ran a swift current. Within an hour we caught 6 bass, not one weighing less than 2 pounds. I caught one that weighed  $5\frac{3}{4}$  pounds. Then we ran into a school of brindle perch. I dislike having them around me when I am fishing for bass. I had just caught one and had him to the top of the water when up came a pickerel at least 18 inches long. To tell the truth it scared me to see that monster come up and grab that perch. I put my hand in the water to pull him in but he flipped up his tail, broke the line and went.

We fished about 15 minutes longer and then pulled up our lines and rowed home, well satisfied with the day's luck.

Nevill B. Jennings, Waterbury, Conn.

#### WHERE TO FIND THE TUNA.

Can you give me the address of any tuna or tarpon clubs in the Eastern States or Canada; or any clubs that would be interested in that sort of fishing. We have in Cape Breton waters a fish which appears to be identical with the leaping tuna of Santa Catalina island. It will take bait readily and is one of the most active and powerful fishes of its size. These fish have never been taken on the rod. They have frequently been hooked with hand lines, and if the line does not break, the angler is glad to cut it to avoid having his boat towed under. These fish look exactly like mackerel but have no stripes on the back and weigh 150 pounds and upward. Some taken with harpoons are said to have weighed over 500 pounds. Many stories are told of these fish, and with all due allowance these monsters afford all the sport it is possible to obtain in a contest of skill against strength. As they remain with us during July, August and September, I propose to try for them this year.

A. W. Woodill, Sydney, C. B.

#### NIBBLES.

Please tell me the name of the fish that is shaped like the perch, is about 6 inches long, has brazen and silver colored scales, a large mouth, and large eyes, with black

iris surrounded by a deep pink, or light red.

Some persons here call them sunfish but I think they are not. They may grow larger but I have seen none longer than 6 inches.

Frank Lane, Mt. Gilead, Ohio.

ANSWER.

The fish you describe is apparently the rock bass, or goggle-eye. It is sometimes called the redeye. Its scientific name is *Ambloplites rupestris*. It belongs in the same family with the black basses and the sunfishes. Its habitat extends from Vermont Westward to Manitoba and Southward to Louisiana and Texas.

The rock bass reaches a length of a foot and a weight of 1½ pounds or less. It is a good panfish, takes the hook readily, but is not a great fighter.

B. W. E.

As a lover of fair play and a man who does not want all the fish in the stream at one sitting, I denounce the trammel, or pocket net, as the lowest and dirtiest means of taking fish that is employed to-day. Take the bass for example. All one must do to be reasonably sure of him is to circle his lair with the net, then get inside and force him either to jump or be caught. Seven times out of 10 he will try to go through before jumping, and is sure to become entangled in the net so fast there is no hope. The more he tries the tighter he is fast. If, however, the hog should fail he will stretch the accursed net across the stream and come and unload next morning; for there is not one chance in 1,000 of the fish escaping and he is sure of them from up or down. It is impossible for them to pass. As long as these nets are manufactured they will be used. By using the net after dark there is little fear of being prosecuted.

C. B. H., Markleville, Ind.

I have been a reader of your magazine several years and though I have read many sportsmen's journals I find none I like so well as RECREATION.

I have fished a great deal. Have never given the fish a chance at all; just yanked him out of the water and put him in a basket. I never was a hog, for I stopped at a reasonable number. This summer I want to fight him fairly, so I should like to have you answer a few questions.

Our river is 300 to 500 yards wide and 20 to 30 feet deep and contains 2 kinds of fishes that I can not catch, black bass and carp. Please tell me where I will find them, what kinds of bait are best and what part of the tide. Is the carp a good fighter and table fish? I never learned to fish

with a fly as I always thought the water was too deep. Is that idea incorrect?

A. R. Prettyman, Galena, Md.

Will RECREATION readers please answer?  
—EDITOR.

The Huron river is noted for its good fishing places. Recently many large fishes have been caught. The latest story originated with George Ackerman who, by the way, is not a fish hog. He was recently fishing down the river, with poor luck, but a young man named Clom caught a carp that weighed 25 pounds and a catfish that weighed 6 pounds, so George claims. As George never juggles the truth, his friends took pains to weigh the 2 monster fishes. The catfish weighed nearly 2 pounds and the carp nearly 6. Carp, Milan, Ohio.

It has been the custom for a party of us to drive to Tasawasa lake, about 18 miles East of Troy. We find there good fishing, an abundance of pond lilies, an excellent camping place and accommodations at a reasonable rate.

A. P. Hall, Troy, N. Y.

Will some angler please instruct me how to cast flies and small minnows? Perhaps W. S. H., Wadena, Iowa. Also what kind of tackle to use.

J. P. Jaeger, Independence, Ia.

OUR NEIGHBOR'S CATCH.

S. C. LONG.

There was a man in our town,  
And he was wondrous wise;  
He hooked a fish one day last June,  
'Twas of enormous size.

And when he saw what he had done,  
He straightway raised a shout;  
That he, with utmost skill, had hooked  
A 22 pound trout!

The line waxed taut, the rod was bowed,  
The man's teeth tight were set;  
As into his boots the water flowed,  
Cried he, "I'll land ye yet!"

And when the people came to see  
This fierce and royal battle,  
They held their sides and laughed with  
glee,  
For 'twas a snapping turtle.

My eagerness to get RECREATION seems to amuse my friends and the newsdealer as well, but I can't help that; I like to read it. I like the way you express your opinion of any and all game hogs, irrespective of station. I think you are doing a noble work and want to see you continue to do it in your independent way.

Dr. R. E. Franklin, Richmond, Va.

## GUNS AND AMMUNITION.

Anybody can shoot all day, but a gentleman will quit when he gets enough.

### SUGGESTIONS TO GUN MAKERS.

I am 52 years old. Since early childhood I have used a gun, both East and West of the Mississippi, and have eagerly watched the evolution in fire arms. While I sanction improvement, I do not approve all the modern complexity in the manufacture of fire arms and ammunition, especially the latter. I see a tendency among gun makers to find "a little nest with a big egg in it"; in fact, they want to produce a gun that will kill anything from an elephant down to a flea, make a thrashing machine, a bobsled, a bootjack, or raise a patch of turnips. There is too much scientific complication in the gun business, amounting largely to dangerous and expensive humbuggery. For shooting, generally, either in war or in the field, there is no need of hard metal jackets and soft points, explosive bullets, etc. The needful points of a practical gun for general purposes are that it shall be plain, strong, simple, convenient, durable, rapid and effective; to which may be added, graceful.

The ammunition for such a gun should be of the class called "fixed"; that is, ready made, as are nearly all modern rifle cartridges; and it should be of sufficient size and weight to be effective. This ammunition should be commonplace, that is, found in cities, hamlets, country stores, etc., all over the land, besides being cheap. The more the kinds of cartridges used in a gun, the more practical is the weapon; hence the popularity of the Winchester repeater, model 1873, using its own and 3 other rifle cartridges; also, as in single shooter for short range, 6 pistol cartridges; amounting in all to 10 cartridges. With such a gun, ammunition can be had anywhere. If there were in the market a fine shot revolver, of 28 ounces, and 5 inch barrel, double action, with the central extractor, using a 44-40-200 cartridge, how much more popular this gun would be. At present all the revolvers using this cartridge are 6-shooters, weighing  $2\frac{1}{4}$  to  $2\frac{1}{2}$  pounds, and are too big and heavy for general use. Yet, as this shot is a little too light I suggest a better gun: A repeater of .41 caliber, with 26 inch barrel, shooting a 41-50-250 center fire straight shell cartridge. The gun should weigh 7 pounds, and by using grey powder, which is smokeless and without residue, the cartridges should be free from grease or other lubricator. Easy cartridges are nasty in a pocket or belt. That the bullet should go straight when fired from a gun, the front half of the bullet should be the heaviest.

To counterbalance the lead shaved off in tapering the front end of the bullet, a little more lead should be reamed out of the center of the rear end of the bullet. This cavity should be filled by inserting a copper nip, in shape like a gun cap, and the end of the bullet left smooth. This is my own device to supersede the soft pine plug used in the old time Mexican minie bullets. This bullet should be smooth on the outside, for grooves in the surface render the flight of a bullet noisy besides detracting from the force and speed of the bullet.

The 41 caliber bullet would be preferable to a smaller one, for it would impart a greater shock, draw more blood and break more bone, thus being more efficient for big game, as well as for military purposes. Such a gun would, as a single shooter, use any center fire pistol cartridge of this caliber in the market, and thus do good work at short range. It would also be of use for farmers on butchering day. Such a gun's own cartridge, the 41-50-250, might be kept in reserve for using the gun as a repeater at greater range; and for general purposes, this would be the most efficient and practical repeater on earth.

For this new gun I suggest an oblong frustum front sight, as it is plain, simple, long and strong; and being thin it will admit a coarse sight when shooting beyond the graduation of the gun, thus making the gun carry up somewhat farther. In form this sight is a half circle minus  $\frac{1}{4}$  its height cut off at its summit, and it tapers at both ends, hence it can not catch into the clothing, or stick the horse, as do all the pointed kinds. The sight should be made of something hard and tough, and of a dull finish so it would not glitter in the sunlight and thus obstruct the vision of the shooter. Perhaps a dull, dark gray finish can be put on steel, or the sight might be made of a dark gray mineral cement, or of horn. As a rear sight, I recommend a short leaf sight, instead of the step sight used on the 44 caliber rifles, with 9 frets, each fret representing 50 yards.

I prefer the Colt action, for it can be used as a double actor, and thus such a rifle could be fired as rapidly as a double action revolver. Furthermore, the sliding action on the forestock enables the shooter to keep a continual hold of his gun, hence he does not jerk the gun stock down from his shoulder as he would if in a hurry while using a gun of lever action. For those using the lever action, I suggest the finger lever of the Winchester model 1873

rifle, omitting the thumb screw which secures the finger lever, for this lever is handsomer than the round end kind, besides not offering a cavity between the rear end of the finger lever and the rifle stock to catch the sleeve or a twig; but the system of the Winchester model 1892 rifle is preferable on account of having a shorter stock of finger lever.

The tendency is too much to small guns using little bullets; a lazy man's outfit. Look at the eccentric drop of caliber by the Government Bureau, the 45 pistol shot, 30 grains powder and 255 grains lead, down to the 38-19-150. The 22, short at that, will be adopted next for the native musketeer. We do not need a gun that will bore a hole the size of a darning needle through a haystack 5 or 6 miles away, as the smokeless 30-30's will do. On the other hand, when a bear or a man is struck at short range, midrange, or long range, with a 45-100-500 from a Sharp's special, he will stay there. Anyone preferring a little, slender bullet in a bottle neck shell is a 30-30 crank. He would be satisfied in shooting an elk 9 times, only 75 yards away. I could have done it with one shot from a 30 caliber pistol. The pistol would have cost \$1.50; the 30-30 rifle \$25. Over in Ceylon a she-buffalo had the hair on her head powder-burned; and after she was shot several times with a 30-30 she got away. Nearly all the tremendous (?) work done by 30-30's has occurred within easy pistol range, say 30 to 60 yards. I have not yet contracted the 30-30 disease, hence I shall not go to war with a popgun. The way poor, wild animals have been maimed by little patent bullets shows a lack of both skill and compassion on the part of the hunter.

Here is a story told by a Montana man: "We had one of their modern, small bore, high power rifles in our country, and it was a terror. When it went off we heard a sound as of an earthquake. The jacketed part of the bullet went through a tree 5 feet thick, sailed down the river 7 or 8 miles, and struck a sawmill, tearing it entirely down and rolling all the logs into the river. One limb of the injured tree fell on a bear, killing it instantly, and splashing a wagon load of fish out of the water. Four elk were so badly frightened they plunged into the river, and were drowned. One deer ran against the splintered tree and was killed. The soft part of the bullet spread out and scraped up all the potatoes an old woman had in her garden, and then the mushrooming began. One piece of this soft point went over the hill and killed 82 wild geese, and crippled 11 more; another piece went out into the valley, killing 125 ducks, and maiming many more, besides scaring one old duck

until she laid a basketful of eggs; another piece went somewhere else, I don't know where, but I guess it is going yet."

We all liked the yarn very much.

John C. Votaw, Marion, Ind.

#### CARTRIDGE CARRIERS.

722,124.—Carrier for Small Arms Fixed Ammunition. Anson Mills, Washington, D. C. Filed August 12, 1902. Serial No. 119,415. (No model.)

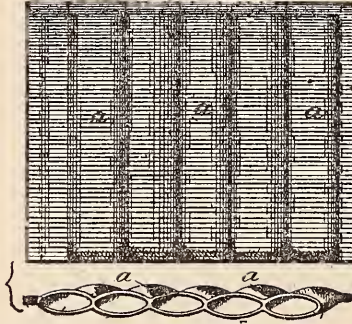

Claim.—1. As a new article of manufacture an ammunition carrier consisting of a pliable band and a group of cartridge receiving pockets on each of the 2 faces thereof,

the pockets of the one group being opposite the intervals between the pockets of the other group.

2. An ammunition carrier consisting of a 3 ply woven fabric, having 2 groups of pockets integral therewith, located on opposite faces of the intermediate ply and opening at opposite edges of the fabric.

3. An ammunition carrier consisting of a 3 ply woven fabric having 2 groups of pockets integral therewith located on opposite faces of the intermediate ply and opening at opposite edges of the fabric, the intermediate ply at each edge being extended beyond the other 2 plies to form a covering flap.

722,123.—Carrier for Small Arms Fixed Ammunition. Anson Mills, Washington, D. C. Filed July 25, 1902. Serial No. 117,037. (No model.)

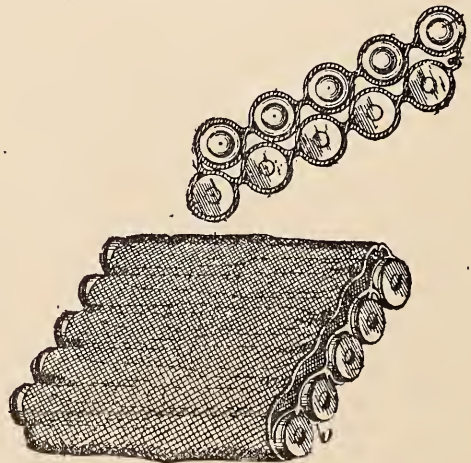

Claim.—An ammunition carrier composed of a band of pliable material provided with groups of cartridge receiving pockets each of which is closed at one end and

open at the other, the mouths of the pocket of one group being at the edge of the band opposite that at which the mouths of the other group are located.

724,190.—Cartridge Carrier. Emil Krough, Cornelius Hogan and John E. Hogan, Chicago, Ill. Filed April 8, 1901. Serial No. 54,888. (No model.)



Claim.—1. The combination with a cartridge receptacle adapted to receive a plurality of cartridges end to end, of means for normally engaging the end cartridge, means adapted to engage a succeeding cartridge and means for actuating said engaging means simultaneously in different directions to cause the release of the cartridge or cartridges between the said engaging means, and the detention of all the remaining cartridges.

2. An interchangeable nozzle therefor, a detaining device carried on said nozzle, and means for actuating the detaining device to release the end cartridge, etc.

#### WINCHESTER VS. IDEAL.

The Ideal reloading tools and implements are generally considered perfection, but I must take exception to the No. 3 special. That tool, in my opinion, does not compare with the Winchester, model '94, tool for general utility, ease and speed of operation.

With the Ideal, the expelling pin and the shell are inserted in the chamber, a slow operation; with the Winchester, 2 or 3 primers may be expelled in the same time by holding several shells in the left hand, passing the expelling pin from one to another, striking it each time with a mallet. Again, the insertion of the new primer is much more easily and quickly effected with the Winchester tool.

Next comes the opening of the mouth of shell. The Winchester tool is provided with a projection for that purpose, which enables the operator to do the work easily and with little or no injury to the shell. The projector on the Ideal tool for that purpose is an unmitigated nuisance. It will not open the shell at all, merely grinding away the point of it. It could easily be made different, and I advise all users of Ideal tools to take their die to a machinist and have it turned down to a proper taper. It could be done without injury to the chamber.

In seating the bullet the Winchester tool has decided advantages over the Ideal. To get best results in shooting, the powder should be carefully settled in the shell without ramming, and then should not be

disturbed in seating the bullet. To accomplish this with the Ideal it is necessary to work the tool upside down; and to get the shell in place is an awkward and clumsy operation. With the Winchester, the bullet is placed in the mouth of shell, standing upright on the table. The die is then placed over it and pressed down until it holds the shell firmly, when the die is screwed in the frame without changing the position of shell. The shell is resized and the bullet seated with the one operation, perfectly, and more quickly than with the Ideal.

Sharp point bullets can also be seated with the regular chamber in the Winchester tool in the following manner: Make a block of hard maple conforming to the shape of the point of chamber, and after hollowing it out to receive the sharp point of the bullet insert it in the point of the chamber. After seating one or 2 bullets, you can shape it to the right thickness to seat the bullet just where you want it crimped. Then it is advisable to stick it in place with a little mucilage. I recently got a 32-40 Winchester repeating rifle as a premium from RECREATION, and as I wanted to use the No. 31,949 Ideal 152 grain sharp point bullet, I contrived this way of seating the bullet with the Winchester tool. It works to perfection. The Winchester Company could easily make these blocks of metal to go with the tool at trifling expense, thus adapting it for both the regular and sharp point bullets.

I might say for the benefit of J. A. Elliot and others wanting information as to the best all around rifle that such a weapon can, in the nature of things, never be made. The nearest approach to it is, in my opinion, the 32-40 Winchester repeater. It is the standard for accuracy, is easy to clean and keep in order, and can be made effective on big game by using express bullets.

G. B. Crandall, Cherry Valley, Ont.

#### SOMETHING ABOUT RIFLES.

I have stated before this that in my opinion the lever action of the Winchester and Savage rifles is far more satisfactory to the sportsman than any bolt action, because he does not have to change the grip when using a finger lever, which certainly counts for much. Furthermore, the exorbitant prices quoted for the above guns in this country make them undesirable for sportsmen. One can buy a well finished Mannlicher, with checked pistol grip, octagon barrel, matted rib, and magazine for a clip of cartridges in the buttstock, for \$16 or \$17 in any gun store in Germany, while \$40 is asked for the cheaper round barrel rifle here. These German rifles can not be excelled for light weight, material, workmanship and accuracy. Such rifles cost about \$30 in Germany. Which of the 2

rifles is preferable? They are nearly alike. Both actions are modifications of the old 1871 model Mauser army rifle, which is still a standard action on the other side for target and hunting rifles. The Mauser has no box magazine, which is an advantage, as one does not have to load by means of the clip, as in the Mannlicher or the 1888 model; but while the latest model Mauser may have advantages over the 1888 model Mannlicher, from a military standpoint, give me the model '88 for a sporting rifle. The cartridge is powerful and big enough for anything. While neither the 2-3 nor the 4-5 jacketed bullet is so accurate as the full mantled, both are satisfactory for hunting purposes, the 4-5 mantled especially. It is evident, however, that the bullet which has 4-5 of its length covered by a metal jacket will give better penetration than a 2-3 mantled, while it expands amply with the full load of powder. I have not dwelt on the far killing power of my favorite rifle. It is true the weapon leaves nothing to be desired in that respect, but no hunting rifle should, as a rule be used at long range. Some might now say they could use a 44-40 just as effectively as high power ammunition. Perhaps so, but it is evident that with the modern gun one is more certain of his game and will probably save it hours of suffering and save his legs as well, by speedily despatching his game. In olden times the hunter took delight in the work of his well trained bloodhound on the trail of the deer he had purposely wounded the night before, but such work at the expense of the poor suffering brute is unworthy of the 20th century. If we must take life, let us do so in the safest and quickest way, without causing any unnecessary suffering.

It appears reasonable to me to use only standard ammunition in a high power rifle and by having different styles of soft points, adapt the rifle to different kinds of work. One will thus be enabled to regulate the penetration and killing power or smashing effect, while the accuracy remains uninfluenced and the sights need not be changed.

F. J. G., New Brookland, S. C.

#### SPARROW GUNS.

I noticed an article in RECREATION describing a miniature sparrow gun, made from a 22 Winchester rifle, smooth bored and chambered for 22 center fire shells. The writer of the article lauds the weapon highly. I tried industriously to rid our premises of sparrows, not long ago, and they seemed to thrive on the 22 caliber shot gun treatment. It was not until I invoked the aid of a 22 rifle and the new Winchester greaseless 22 short that the birds left the

yard for good. My little shot gun was a 22 smooth bored Flobert, chambered for the 22 long shot cartridge. The shot charge in this shell varies from 75 to over 100 No. 12 shot. Its penetration is good, and the noise is slight. I found, after much shooting and many unexplainable misses, that at 25 to 30 feet it would scatter over an area of about 6 inches, making a pattern that would kill a sparrow very dead. But, unless the gun was kept clean by swabbing after each shot, it would ball the shot so badly that the bird would be either cleanly missed or cut into ribbons. I made several targets at 20 feet to 20 yards where the shot all entered the paper in a solid mass, making one hole and penetrating an inch of soft pine. I shot 2 sparrows on the wing, and missed so many others that it disgusted me, and I fell back on solid bullets and a repeater. The new 22, greaseless bullet, smokeless powder cartridge is a dandy. It has a much harder bullet than the ordinary 22 black. It carries up to all short ranges, shoots remarkably true, is cleaner than anything ever before invented in this ammunition, and is cheap.

Another new thing on the local market is the Robin Hood smokeless powder for shot guns. This is a good, strong, clean and quick product, and the manufacturers have resolutely kept out of the combine into which Peters and other companies have gone. Robin Hood took my fancy from the start and I have used many hundred loads of it with excellent results. It is a moist burning powder, giving great velocity and little recoil. It is loaded by bulk measure, and as much as  $3\frac{1}{2}$  and  $3\frac{3}{4}$  drams may be fired in a 12 bore without discomfort. The Robin Hood people are putting on the market their factory loaded shells and these can now be obtained in Topeka and in Kansas City, Mo. If any of the Western readers of this magazine have used Robin Hood I wish they would let me know how they like it, and we can compare results.

Chas. H Morton, Topeka, Kan.

#### A BIT OF RIFLE TALK.

As some of your readers know, I am one of those rabid rifle cranks who never rest content until they have tried every new weapon and rifle or cartridge that is put forward.

Yesterday I finished a few experiments with the new 35 caliber Winchester. As a result, I'm sore, not about the gun, but about the shoulder.

The 35, to my notion, is a happy medium between the much discussed 30s and the many large calibers. The advocates of each will find their favorite points embodied in this new cartridge. While the 30-40 has long been my favorite, I have often



wished for just a wee bit more stopping power. I had deer and elk run away from me last fall in Colorado which, by all the rules of gun lore, should have dropped in their tracks. The 30-40s would tear all kinds of holes in them, but still some animals were not persuaded to stop short of many yards. Shot with this new 35, with its heavier ball and higher velocity, I believe few animals will cover 20 yards after being struck.

On examination the shell showed 50½ grains powder behind a 252 grain ball. The velocity is 2,200 feet a second. The trajectory almost equals that of the 6 m-m navy arm. A better hunting rifle for big game will be hard to find.

But one thing I strongly advise my brother cranks to remember, when using the gun. Get the thickest recoil pad on the market and fit it to a shot gun butt piece; don't order the gun with rifle butt for appearance sake. The Winchester people still insist on furnishing graduated sights with their high power guns. What for, I don't know. Try the Lyman leaf sight; fold down the crotch, raise the bar and keep it raised, and use the ivory bead for front. Practice with these and you will be in much better game shooting trim next fall than if you use globe, peep, crotch and other useless sights. These latter are well enough for target shooting, but any hunter will tell you the difference between that and game killing.

Try this new caliber, brother cranks, and let us hear from you.

Oklahoma, Minneapolis, Minn.

#### THE LIMIT WITH A .303 SAVAGE.

Last summer I bought a Savage, .303, 22 inch barrel, and I find it a sure killer for big game. The sportsman who invests in a .303 gets the best big game gun on the market. With all due respect to the Winchester people and other good makers, the Savage is the most up to date and the 20th century weapon. Fitted with Lyman combination rear sight and Lyman ivory "Jack" front, it is simply perfection.

Leaving Middletown, Conn., October 10, 1902, accompanied by Dr. Barnes, of New London and W. T. Dewart, of New York, West Branch pond, Maine, was safely reached by 8 p. m. Saturday. The last 4 miles we made by the aid of the doctor's bicycle lantern. Hunting, the first few days, was unfavorable on account of high winds and the dry condition of the leaves.

The 17th changed conditions a little; rain had fallen Thursday night and early Friday morning and, with a light, steady wind, made prospects more favorable for a good day's sport. In just one hour from camp I brought down a fat doe; one shot from the little gun was sufficient. Satur-

day and Monday more high wind and dry leaves made it next to impossible to get near game. Rain Monday night and until 5 a. m. Tuesday, October 21, preceded an ideal day for hunting. At 7.30 Charles and I started to look for a big buck. At 9.25 the Savage cracked again, and there lay a fine fellow, with an excellent head. One shot from the little gun had done the deed.

The same day I brought down a bull moose with 8 points. One shot would have been enough for the old fellow, for he leaned against a tree until I got within 40 feet of him and sent another bullet into his neck to end his misery. My first shot ploughed through his liver, cutting it into fragments, and proving conclusively the great killing power of the Savage.

There is no better guide in the Maine woods than C. H. Randall; his camp accommodations and table board are faultless.

William Duncan, Middletown, Conn.

#### THAT WOODCHUCK AGAIN.

For hunting woodchucks I use a Lefevre 12 gauge shot gun, especially if the grass is tall, and by a little strategy I have fairly good success. My load usually is 40 grains Laffin & Rand powder, 1½ ounce No. 7½ chilled shot. With that combination I can get the chuck every time up to 35 yards. I use a 32-40 rifle. It does not require much skill to get a chuck with that up to 50 yards; but for skill and fine shooting one should go out after the haying season is over, when a chuck can see and be seen across a 40 acre field or even farther. Then hold steady. At such times I have used the 30-30 with a Mogg telescope. With that combination one does not have to sneak far to get within range. I have killed a few chucks with the 22 Winchester repeater. That does well if one is near enough to make the head the target; but if only hit in the body the chuck will get home. For lively shooting one should be in Kansas or Arizona, where the prairie dog pest is. There one can ride along and if his horse will stand fire, can keep a 22 warm. These little fellows look out from the mouths of their holes and if they are not hit in the head they usually get in out of reach. Here in Central New York there is little use for a rifle larger than 25 or 30 caliber, unless it may be for target practice, and even then the 22 with its variety of cartridges will furnish lots of amusement.

H. H. Vary, Skaneateles, N. Y.

#### SMALL SHOT.

I note the article by the gentleman who so freely expressed himself in *MARCH RECREATION* in regard to Savage rifles. I have a Savage .303 which I have used for

the past year, and I have never had it jam, stick or go wrong in any way. I have seen men who knew no better than to place the cartridges in the magazine wrong end first. Naturally in such a case the action would balk. Have had the pleasure of using both Winchester and, alas! Marlins, but would not exchange my Savage for either of them. I surmise that if there was any trouble with that Savage the man behind the gun was responsible.

I reload my own cartridges and use them over and over. My perfect target and small game load is 15 grains Savage No. 1, smokeless powder, and a 32-20 Winchester 115 grain soft point bullet. The 32.20 bullet is exactly the same diameter as the .303 namely, .311. I use the Winchester reloading tool and prefer it to the Ideal, as the cartridge is crimped and resized its full length all in the operation of reloading.

Would like to hear from someone who has used the Magniscope rifle sight for hunting purposes.

Ralph K. Mussey, Warren, N. H.

There is no better nor neater gun made than the Ithaca. For shooting qualities no gun can beat it. I have used a No. 4 grade which made a pattern of over 400; and one can have an Ithaca made to order, without extra cost.

The Winchester 25-35 is as nearly an all around gun for this country as one will find. I used small loads of black powder and hard bullets for small game and find it just the thing for rabbits, grouse, etc. With a full load of smokeless powder and soft point bullets it would be all right for deer.

I have also used the 22 Marlin. When the magazine is full, there is trouble, but when I had in only 15 cartridges it would work as smoothly as any gun. For all that I would not get another till they fix the action, for, when one is out after big game, he does not want it all to escape.

Will some reader tell me his experience with the 33-30 Winchester with full load black powder and wire patched bullets? Also small loads with same bullet; also King's semi-smokeless, same loads?

M. E. Daniels, Orrock, Minn.

Some of the men who rush into print and tell of the merits and demerits of certain rifles should give us satisfactory proof of their ability to hit a tomato can 5 times in succession at 60 feet. If some of these writers were to go into the back yard and try their skill at an inch target 50 feet away they would soon discover how easy it is to get on the outside of it. Then they

might learn where the blame belongs when they shoot 200 or 300 yards and miss.

They write of the killing power of different rifles and it is enough to send a novice wrong on many good rifles to read such stuff. Every beginner should practice with a good rifle at not over 75 feet, using a small target; and when he gets so he can put a ball into it once in a while and put all the rest within one inch of it he is fit to go after big game.

Use a 32-40 or a 38-55 and if you can do good work at 50 to 75 feet on an inch target you may bring home some game. If you use a black powder gun you will never be sorry, for it will not disappoint you.

H. A. Plante, St. Johnsville, N. Y.

H. P. Brown, of Auburn, N. Y., asks for information concerning a target rifle to cost him about \$25. He does not state whether it is wanted for 25 yard gallery shooting, or 200 yard range work; or if the latter whether for off hand or rest shooting. I assume it is wanted for 200 yards off hand shooting. In my 10 years' experience in range shooting I find that the majority of shooters use the 32-40 cartridge, reloading the shells to suit their tastes. The Winchester single shot rifle for this cartridge is a good arm and will make 10 shot groups in a 4 inch circle at 200 yards from a rest, with surprising regularity. Get a Swiss butt plate, mid ringed Vernier rear and wind gauge front sights, and procure a barrel to suit your strength. The No. 3 weighs about 9½ pounds and the No. 4 about 11 pounds in the 30 inch length; cost about \$18, plain stock. Have that target shooter's abomination, the Rocky mountain, or buckhorn rear sight, left off and no slot cut for it.

V. R. Olmstead, New York City.

It is amusing to read the experience of H. R. Van Sommel in February RECREATION. He has a 30-40 Winchester, tries it on boiler plates, steel rails and dead horses and finds it deadly on all. It is a pity he did not get his 30-40 6 or 7 years ago so he could inform the world of shooters of its terrible killing power. He says, "Come, brethren, be honest. Which is the most killing gun, a 30-40 that whips a bullet through a 6 foot oak or a 45 that perforates one foot in soft pine?" Yet the makers of his rifle give its penetration as 50 inches of soft pine.

Come, Brother Van Sommel, be honest. Just tell the readers of RECREATION that you used a yard stick instead of a foot rule when measuring that 6 foot oak; in future do not laugh at the .45 caliber since the new 45-90 high velocity bullet travels faster than the 30-40 bullet. When it comes to striking power, your 30-40 is not

in it with the 45, as the base of your bullet barely covers the flat point of the 45.

W. Mashek, Kewaunee, Wis.

To Mr. Pierce I would say, I have already related my experience with a 25-35 and my article appeared in RECREATION. I will never buy or carry another 25-35 on a deer hunting trip. If Mr. P. killed 4 bucks in 5 shots with one, he certainly got enough, and anyone who knows what a 25-35 will do can say that he must have been right up where he could place his bullets. If the man with the 45-70, had the same chance as Pierce, one ball from that gun would have been enough, without the wire fence. Any man or woman who hunts deer will agree with me.

Mr. Pierce may be a crack shot, but if he will come to Minnesota next fall and hunt in the tamarack swamps, pine stumps, and underbrush, it will worry him to pick up 4 deer in 5 shots. However, this fall I went back to a 30-30 Winchester, 20 inch barrel and succeeded in killing 6 deer for a party of 2. My partner did the driving and I did the shooting. No wounded deer got away from me.

A. Huff, Minneapolis.

In a recent number of RECREATION a correspondent wrote of having trouble with his Savage rifle owing to the fact that the trigger and lever lock, or safety slide, soon became so loose as to slip backward and forward too easily. Several of my friends have had the same trouble with their rifles. This annoyance may be remedied by dismounting the rifle according to the instructions given in the Savage catalogue. Take out the trigger and lever lock, and make the slit in the rear end of the same a little wider, using a screw-driver or other instrument for the purpose. In order to prevent breaking, the lock may be fastened in a vise while widening the slit, but I did not find this necessary. The lock may be made to work hard or easily, depending on how much you widen the slit. The whole operation may be finished within half an hour. My ignorance of how to remedy this trouble cost me several good chances at deer and turkeys last year.

John C. Futrall, Fayetteville, Ark.

Under the Heading "A 12 Guage Load" I note Frank A. Wood is advised to use 38-42 grains of Laffin and Rand powder. This is all right; I have used 45 grains safely; but with the new Laffin and Rand Infallible this will not do. Thirty is the limit in 12 guage. With this powder, or Ballistite in  $\frac{3}{4}$  base shells, the load can not be improved; but 26 grains is enough for a Ballistite load.

Cleaning .30 caliber rifles is vexatious,

but get a Remington-Lee. The action can be dismounted in a moment, and you can get at both ends of barrel at once. Besides the ease of cleaning you will have the best rifle made in America. A look through one of these barrels is a revelation in cleanliness and depth of rifling. They match a Mauser in cartridge, and the Remington is made for all, while the Mauser is not in the same class with America's best gun, notwithstanding the advertising the Mauser gets.

S., Leadville, Colo.

I have always used small bore rifles since the advent of smokeless powder ammunition. If you want a rifle for moose, deer and bear try the .32 caliber Winchester Special if you care to reload for target practice or for use with telescope sights. If you do not care for the above sights I recommend the .33 Winchester. I have one of each and both give perfect satisfaction. I used the .33 last year in the woods and got 2 large bucks. This gun is light and handy, has 24 inch barrel, and is powerful. I prefer it to the .30-40 on account of its lighter weight and larger caliber with a trifle more velocity. The rear sight is much nearer the eye than on other rifles, and it has a neat ivory hunting sight on front which can be changed for ivory bead front. It has a nicely rifled barrel, well finished inside and out, and very accurate. If the Savage or Marlin Companies make such barrels I have yet to see one.

F. F. Cooley, Waterville, Me.

I notice in RECREATION a query from Mr. A. W. Crampton in regard to Robin Hood smokeless powder. I am using Robin Hood powder, both at the trap and for hunting. It is the best powder I ever used. I shoot a great deal at the trap and have used all makes of powder. For pattern and penetration Robin Hood beats them all. Another good thing about it is, when you are through shooting you can clean your gun by simply wiping it out with a rag.

All other powders leave a scum on the inside of the barrel that has to be scoured out with a brass cleaner. If Mr. Crampton will give Robin Hood a fair trial he will never use any other powder.

Will also say to Mr. Turf, of Pittsburg, that he can use Robin Hood smokeless powder in any kind of gun or shell, including brass shells. A black powder primer will explode it.

J. N. Lund, Rochester, N. Y.

When I was a boy it was my good fortune to own a Hollis 16 guage gun. As smokeless powder had just come to no-

tice, I went to our old gunsmith, and bought a quantity in bulk, not obtaining directions for loading it. Leaving my measure set as for black powder, I loaded a lot of brass shells and wadded them heavily with 12 gauge wads. The result was wonderful execution on rabbits, but the gun gave a sort of metallic ring and a sharp recoil when fired. It also burst about one quarter of the shells. On firing one at a fence board, to test penetration, the shell burst near the head. The other part of the shell, with shot and wads intact, was forced through the barrel and made a hole through the board as though by a bullet, with seemingly no injury to the barrel. Always follow directions in loading smokeless powder.

J. D. Snyder, Lowell, O.

John Nordstrom complains in RECREATION of the deterioration of nitro powders, and asks if others have noted it. Another correspondent says that Remington guns do not shoot close enough to please him. For the benefit of both I describe a test I made recently.

Powder, Robin Hood, loaded by Kennedy, of St. Louis, in 1897. Shells, Nitro. Loads, 3 drams powder,  $1\frac{1}{8}$  ounces No. 3 soft shot. Target,  $8 \times 5\frac{1}{2}$  inches. Distance, 40 measured yards. Gun, Remington ejector, 12 gauge,  $7\frac{1}{4}$  pounds, 30 inch full choked barrels. Average number of pellets in target, 19. Perforation, 9-16 inch in Florida pine. No. 3 shot was used because it happened to be in the old shells.

Two year old DuPont gave good penetration, as, also, did one year old Ballistite.

L. Shannon, Bonifay, Fla.

I noticed in RECREATION that J. F. Roberts would like to hear from someone who has hunted woodchucks. I have; with a .22 caliber Colt, using the short cartridge with black powder. I never lost a woodchuck in the short time I hunted, as the distance was not great, and I hit them all in the head.

My brother hunted woodchucks with a rifle, using 38 long Colt's, in 3 years of hunting he only lost one woodchuck. The year before, he used 22 shorts on a .22 caliber rifle, and did not secure any game, unless it was hit in the head.

F. S. Mathias, Brooklyn, N. Y.

If I called the 25-35 any bad names, I will not take any back. Mr. Powell may keep his gun, as I have a 30-30 Winchester, which is a 10 times better gun. Any man who has hunted deer will agree with me. In 1901 I experimented with the 25-35 and my partner and I brought home 5 deer between us. Aside from that, I lost a buck, shot through the upper part of the shoulders, and a large doe, shot through

the flank. There being no snow, I could not follow or track them.

A. Huff, Minneapolis, Minn.

In answer to G. N. McKay's inquiry in January RECREATION as to Marble's front gun sights, would say, that I used one while on a hunting trip in St. Louis county, Minnesota, last fall, also one of their No. 1 hunting knives, a No. 5 axe and one of their compasses; all of which I recommend as being all that is claimed for them by the manufacturers. These goods are first class in workmanship and material, and entirely satisfactory in use.

Henry L. Seire, Morton, Ill.

I read in RECREATION that W. A. Barr doubts the penetration of the 303 Savage rifle. The rifle will do just what the makers claim. I tested mine on hemlock logs shot in the end. It gives it penetration of 28 to  $38\frac{1}{2}$  inches; and crosswise of the grain 39 to 45 inches. My next test was made in clear white pine boards, crosswise of the grain, and the penetration was  $48\frac{1}{2}$  to 53 inches.

H. C. Watson, York, Pa.

Replying to H. C. Clark's inquiry about shooting balls in a cylinder bored shot gun: If the barrels are reasonably heavy and strictly parallel in bore, such a gun will do satisfactory work. The ball should be a little smaller than the bore, so it will take a patch. It should be seated on a  $\frac{1}{2}$ -inch felt wad over powder. I have done great execution on deer with such loads.

W. A. Linkletter, Hoquiam, Wash.

I wish some reader who has used the Magniscope rifle sight would write of his experience with it. It does not elevate, therefore I do not see that it would be of any use except at close range.

.30-30, Westmount, Can.

What is the best caliber for game up to coyotes?

Buck Shot, Milnor, N. Dak.

RECREATION is sent me by an unknown friend, and I extend him my sincere thanks through the magazine. I am a traveling salesman. RECREATION is very popular among the traveling men, and they all delight in your frying pan.

A. W. G., Elyria, Ohio.

RECREATION leads all sportsmen's journals. I like to see the fish and game hogs get roasted in RECREATION, but the word "hog" is not mean enough for those long bristled fellows. They need it where the chicken got the ax.

A. W. Stone, Morrisville, Vt.

## NATURAL HISTORY.

When a bird or a wild animal is killed, that is the end of it. If photographed, it may still live and its educational and scientific value is multiplied indefinitely.

### HOW TO CATCH SNAKES.

FRANK G. SPECK.

In response to the inquiry of V. A. L., in "December RECREATION": It is difficult to induce a snake to enter a trap. In order to understand this, one must consider that, contrary to the laws governing most other animals, a regular or daily supply of nourishment is in no wise requisite to the snake. He takes his food at random, consequently a trap containing food might remain unnoticed indefinitely by the intended victim. Unlikely as this may seem, it can be readily understood by anyone acquainted with the snake's desultory nature.

A plan, however, that has sometimes succeeded is to fasten a frog or a mouse by the leg to a stake in a snake-frequented locality, allowing the creature room to move about freely. If a hungry snake approach, he is likely to devour the bait, thereby securing himself to the stake by the same ties that held the tempter. The sort of bait used in each case must be in accordance with the snake's customary diet; toads, frogs, mice or birds for the *Crotalus* and his relatives. In addition, the copperhead is fond of the wood frog, *Rana sylvatica*. The trapper, however, must attend his traps often, for in a short time the process of digestion will dissolve the swallowed bait and the cord will be released; likewise the snake.

Another method, even less certain than the former, is to bury jugs, leaving their mouths level with the ground, in the proximity of a snake den, preferably near a hole. In this case there is the probability of some ophidian rambler entering in search of peace and quiet. When once within he will be obliged to remain on account of the smooth interior of the quasi-snake-hole.

As V. A. L. inquires merely about traps for catching reptiles he is presumably aware of the forked stick apparatus, which is most satisfactory and efficacious in use.

"Is there any way to remove the poison glands of a rattlesnake?" Yes. By the careful use of a lancet the entire system of fangs, including the embryonic stages, may be so thoroughly removed that they will never grow again. From that time forth the snake necessarily starves, for, deprived of his natural method of taking food, he will adopt no other. The process of stuffing, however, can often be successfully practiced; and the number of alleged snake charmers who employ this artificial means of administering nourishment attests its adequacy. The removal of the fangs alone

results in their speedy replacement by others forming from embryos situated immediately posterior to the fang proper. It is important, when venomous snakes have thus been operated on, to wash their mouths frequently, as the secretion of virus by the entire system and its concentration in the

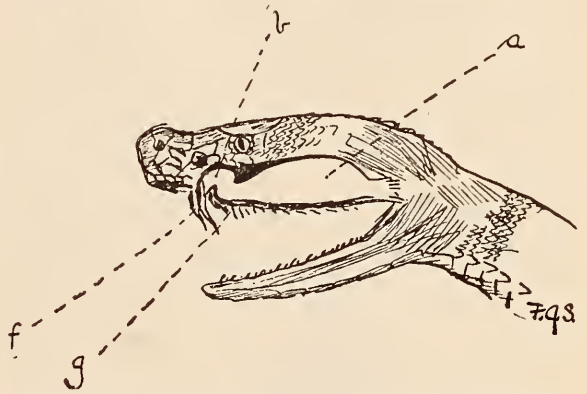

mouth is by no means deterred by the extraction of the glands. Consequently the bite of a fangless rattler is dangerous merely from what venom has become mingled with the other juices resident in the mouth. It is also noteworthy that in these snakes the tendency to strike is much lessened. They often seem to realize their condition, accepting their fate with painful resignation.

As regards the scientific antidote for the *Crotalus* bite, I can do no better than refer V. A. L. to the investigations of the late Dr. Stejneger, who, in his admirable paper on the venomous snakes of North America, says:

"Mitchell and Reichert had confirmed the destructive action of certain chemicals, used as injections, on the venom, notably permanganate of potassium, ferric chloride, iodine and bromine. To these Kaufmann adds chromic acid, which he highly recommends as a remedy for local lesions."

The first of these, permanganate of potassium, is to-day the most favored among those who are accustomed to handle venomous reptiles. There are, too, countless rough and ready cures advised, some of which are helpful, some harmless and others decidedly nocent. Among the latter is ammonia, which destroys the veins and increases the heart action, thus working in direct conformity with the venom.

A LONE FISHERMAN.

W. O. DOOLITTLE.

The past winter was severe in the village of P——. There was a scarcity of bird life. Nearly all the feathered inhabitants had deserted the place for a warmer coun-

try, and there were left behind only a few of the hardier winter species, such as the jays, woodpeckers and chickadees. Even the omnipresent and impudent English sparrows seemed to keep unusually silent and fought shy of the cold winter blasts which swept the snow-laden earth.

Shortly after the opening of the New Year I chanced to be passing over a bridge which spanned a small river near the town. There I first met my lone fisherman. The day was bitterly cold. The wind was fierce and a driving sleet was falling. Suddenly, above the whistle of the wind, I heard a hoarse rattle. The sound was strangely familiar, yet I could not for the instant recall it. I heard it again, looked in the direction whence it came and the mystery was solved.

Perched on a high telephone wire, which was strung across the river, was the blunt, top heavy and peculiarly shaped bird which

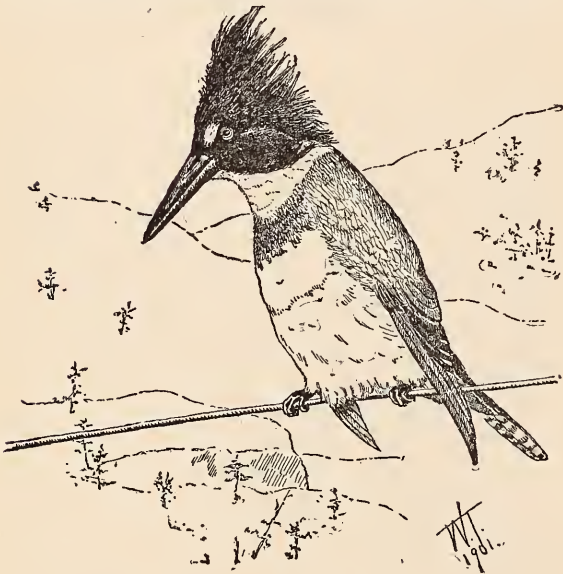

frequents our streams in early spring and summer. Surely it was our old friend, the belted kingfisher; but what was he doing here to-day? What strange fancy had led him to remain at the frozen North, while his fellows were luxuriating in the sunny South? Where could he find the fish with which to sustain life when the river was frozen over with ice a foot thick? My last question was soon answered.

Under the bridge was a dam, which had been built to furnish water power for a mill, and the action of the water in running over this dam prevented a small place below from freezing. Through this hole in the ice must come a winter's store of provisions for our kingfisher. I was rewarded a moment later by seeing him swoop down to the water with a heavy splash and bear aloft a shining fish to his perch on the ice-bound wires.

I visited the spot many times after that and seldom failed to find him there. Day

after day he sat on the wires, with his eyes fixed on that precious spot. During the long, cold days that followed he remained and seemed to thrive, though the wind threatened often to dislodge him from his precarious position. There is splendid angling in that stream in the spring, but during those days, when the mercury hovered near the zero point, this bold bird was the sole pursuer of the finny tribe. Spring came at last and he was then joined by his relatives from the South. Later he became engaged in the respectable duties of providing for a family. Though none can tell what prompted him to remain North, yet who can help admiring his brave and patient spirit?

#### TAMING A WILD RABBIT.

Around my suburban home lives a remarkable rabbit. We saw him first in June. He was about half grown, and the children caught him and put him in a little house. The next morning he escaped, but the experience did not induce him to quit the neighborhood. A few days later we saw him again, eating young white clover on a recently seeded lawn. When he was approached he ran under the front porch. I determined to see if I could not tame him. After several attempts I succeeded in approaching him with some willow brush, which he ate with evident relish. Some days later I offered him bread, which he also seemed to relish. About the first of July he was sufficiently tame so he allowed himself to be approached, and would sniff at any morsel that might be taken him. After several futile attempts I succeeded in getting a good photograph of him at a distance of 7 or 8 feet. Late last fall he was plump and fat and a little larger than the average cottontail. I had thought him a full blooded wild cottontail, such as are numerous in the suburbs, but by fall he was so tame that I could examine him closely. He has a white mark on his nose. His left foot is white, and there is a little white on the edge of his ears; also a fairly large white mark on his breast, which, however, does not show except when, rarely, he sits up on his haunches.

During the winter we did not see him, and for a while I was afraid he had fallen a prey to some rabbit catchers that I had seen, or that a dog had found him napping; but after some time I noticed his footprints leading under my front porch. Sometimes I find him under the porch at dusk, when he will come if I call him. Then he will disappear for 2 or 3 days and again reappear. He is now so tame that he can be induced to come up 5 or 6 steps on the kitchen porch for a meal of dry coffee cake, showing great fondness for the sugar on it. Once while he was eating, a dog

passed on the other side of the house. Bun-ny's ears began to go back and forth and he hopped down the steps. I frightened the dog away and the rabbit at once returned to my call. He knows the members of the family and pays no attention to their goings and comings, but is always on the alert against strangers and dogs. I think he is a hybrid between the wild cottontail and some species of tame rabbit. It was not difficult to tame him, but he has inherited the remarkably watchful instinct of the wild cottontail.

Have any RECREATION readers made similar observations?

D. Lange, St. Paul, Minn.

#### THE BITTERN, WOODCOCK AND OSPREY.

Many explanations are given of the manner in which the bittern, *Botaurus centiginosus*, makes his pumping call of "ker-plunk, ker-plunk," some claiming he makes it with his foot; others by plunging his head into the water. When out on a small lake one May morning I heard the familiar sound. I searched the reeds with my telescope, located the bird, cautiously paddled within 25 yards, focused the 'scope on him and soon he uttered his call. At that short distance a gurgling sound could be heard, which seemed to begin low in the throat and to ascend. When this sound reached the mouth the neck shot out straight, the bill opened wide, and a loud "ker-plunk" was uttered several times. During this performance the bird looked as if it were vomiting. I watched the bittern nearly an hour, and during that time it swallowed no water. I do not think water in the throat is, as some authorities claim, required for the utterance of the call.

The song of the woodcock, *Philohela minor*, is not often heard, but is well worth listening to. One evening I was in a little swamp and heard a woodcock uttering his nasal "packe, packe." I approached as near as possible and waited for him to tower. He soon did so. I could hear his wings swishing as he rose, and as soon as he commenced to descend he began twittering a low, sweet song, which he continued until within a few feet of the ground. He descended near me and began his "packe, packe" again. I could hear a "quer-r-up" prefacing each "packe."

An osprey, *Pandion haliaetus carolinensis*, which I observed fishing, flew slowly over the water near, poised an instant, then dropped feet foremost into the water with a loud splash, making the spray fly in all directions. He failed twice, but secured a fish the third time.

A. B. K., New York City.

In RECREATION C. O. Moseley, M.D., of Lytle, Ga., mention crossing the Gulf in

April on a foggy morning and finding a variety of birds in the riggings of the ship. It is not the habit of small birds to migrate with herons. However, in a fog, which is worse than rain, they become so burdened with weight and exhausted they will alight on anything. No doubt the first birds attracted by lights long before daylight hovered about until they could see to alight. Nearly all birds when migrating start in the evening. Going North they start across the Gulf always with a gentle North wind, which assists them. Frequently adverse winds destroy thousands. While April is the month for all summer birds, our early spring birds cross the Gulf in February and March. Any April night with a breeze from the South the air is full of the different calls of warblers, orioles, scarlet tanagers, summer tanagers, etc. The latter are rarely farther North than the middle of Indiana and Illinois. South America is the oriole's winter home. As soon as it has its young reared and all the tame cherries are gone one will find orioles where there are wild cherries. Moulting commences about July 1st, hence one then hears no song from them. In late August and early September they depart in easy stages until the coast is reached, feed for a few days and cross the Gulf.

Via Rocks Smith, Oklahoma, O. T.

#### PROBABLY A REDPOLL.

What species of junco is it that we see picking the seeds from weeds in the fields? They are seen mostly in large flocks. The birds have a pink spot on their throat and upper part of breast, which gradually lightens into a gray farther down the breast and under the tail, which is quite long. I can generally tell this bird when I see it by the way it runs on the snow. When a flock has settled on a field there is constant squabbling over some choice seed. The English sparrows like to follow the flock about. The snowbirds do not object and appear to be peaceable.

Clyde L. Williamson, Erstville, N. Y.

#### ANSWER.

The only junco found in New York is the slate colored junco, *J. hiemalis*. The bird described is probably the redpoll linnnet, *Acanthis linaria*. Linn.—EDITOR.

#### NATURAL HISTORY NOTES.

In November RECREATION A. C. Thatcher, Urbana, Ohio, inquires if any reader of RECREATION knows of rabbits eating flesh. Yes, when flesh is frozen they will eat it. I have seen evidences of this at different times. In Northern Minnesota, in '89, I tried to poison wolves and used rabbits' flesh for bait. Several times there were fresh rabbit tracks to the bait, which was

gnawed, and a few steps away the rabbits were lying dead, poisoned.

The wolves did not in a single instance forget themselves. They always preferred to hunt, and thus obtain a warm meal, free from any dangerous charges. As long as the baits were visible the wolves walked respectfully by; but when the snow covered the baits, the beasts planted a mark on top of them.

A. N. Wikander, Usk, Wash.

I notice in RECREATION the measurement of elk horns belong to W. C. Darling, of Henderson Harbor, N. Y. I have a set with the following measurements: Spread, 53 inches; length of left horn,  $53\frac{1}{4}$  inches; first prong, 22 inches; second prong,  $17\frac{1}{2}$  inches; third prong,  $16\frac{1}{4}$  inches; fourth prong,  $23\frac{1}{2}$  inches; fifth prong,  $7\frac{1}{2}$  inches. Right horn, 53 inches; first prong, 21; second, 19; third,  $15\frac{3}{4}$ ; fourth,  $22\frac{1}{4}$ ; fifth, 13; around nut,  $11\frac{1}{4}$  inches; above nut,  $9\frac{1}{4}$  inches.

While mine are no longer, they are exceedingly heavy, with extra long prongs throughout, very even and beautifully shaped. I brought these horns out from Taylor's fork of the West Gallatin river, in 1895.

P. H. Tomlinson, Salesville, Mont.

I have a deer's horn which grew in the crotch of an oak tree. The bottom of the stick is  $7\frac{1}{2}$  inches in diameter, the top of large branch 6 inches, and the small branch  $2\frac{1}{2}$ . The horn has 4 points. The wood grew around the horn between the second and third points and covered all but the tip of the second point. The points hang downward, while the base of horn is 6 inches higher than the outer end. Some rodents had gnawed the tips of 3 prongs. I should like to know, through RECREATION, how the horn came in the crotch, and what animals gnawed the horn. It was 8 feet from the ground when cut.

L. M. Badger, Ouaquaga, N. Y.

Will RECREATION readers please answer?  
—EDITOR.

Recently I was strolling along the banks of a stream when I saw what appeared to be a bunch of dead leaves suspended from a branch. Closer inspection revealed the skeleton and feathers of a Western robin, *Merula migratoria propinqua*. The bird had evidently been carrying a piece of thread to its nest when it stopped to rest on the limb of a thornapple bush. This thread became caught around the feet of the luckless bird and afterward around a thorn on one of the branches. The bird was thus made a prisoner and left to beat out its weary life. I have heard of birds being

caught around the neck with thread, horse-hair, etc., but never of one being executed with the noose about its feet.

L. H. McMorran, Spokane, Wash.

I have been a reader of your magazine for some time, and have been much interested in the several departments. Recently I heard a story that might come under the head of natural history. A gentleman said that during the oil excitement on the Little Kanawha river in West Virginia, some 35 years ago, he caught a catfish weighing 67 pounds, that had 2 squirrels in its stomach. He also said that near the same place he once shot a duck in mid-stream, which disappeared before he could reach it. Some of the natives informed him that it had probably been captured by a catfish, and cited cases where fish had been caught with ducks in their stomach.

Reader, Newport, Ohio.

I should like to know where our common wart toad is at this time of the year. Do they deposit their eggs in the water now and is the croaking of the alleged frogs in the spring made partly by the toads? That is my impression, but I do not know whether it is correct.

W. S. Hickox, Middletown Springs, Vt.

ANSWER.

The common toad gives a little whistle, and does not croak as frogs do. Toads are now in the water, laying eggs, the same as frogs; but their eggs are laid in strings, while frogs' eggs are laid in bunches.—EDITOR.

What is the best method of preserving birds and butterflies?

William D. Crooks, Jr.,  
Burlingame, Pa.

ANSWER.

Skin them, poison the skins with arsenic and alum, and either stuff with cotton and keep as unmounted skins, or have them mounted by taxidermists.

To preserve butterflies, mount each one on an insect pin, spread the wings on a drying board until dry, then place in an exhibition box, which should be as nearly as possible air tight and insect proof.

W. T. H.

John Sickels, living here in Chicago, has a pet gray squirrel. He says in the summer, when butterflies are plentiful, it will eat them with a relish. It is fond of small birds. The squirrel will pick all the feathers off a bird and eat the flesh ravenously. I have seen many gray squirrels, but never saw one that would eat flesh. What do you think about a squirrel eating meat?

H. C. Beahler, Chicago, Ill.



# THE LEAGUE OF AMERICAN SPORTSMEN.

## GENERAL OFFICERS

*President*, G. O. Shields, 23 W. 24th St., New York.

*1st Vice-President*, E. T. Seton, 80 West 40th St., New York.

*2d Vice-President*, W. T. Hornaday, 2969 Decatur Ave., Bedford Park, N. Y.

*3d Vice-President*, Dr. T. S. Palmer, Dept. of Agriculture, Washington, D. C.

*4th Vice-President*, A. A. Anderson, 80 West 40th St., New York.

*5th Vice-President*, Hon. W. A. Richards, General Land Office, Washington, D. C.

*Secretary*, A. F. Rice, 155 Pennington Ave., Passaic, N. J.

*Treasurer*, Austin Corbin, of the Corbin Banking Co., 192 Broadway, New York.

## ALASKA DIVISION.

Dr. E. M. Rininger, Chief Warden, Nome.

## ARIZONA DIVISION.

M. J. Foley, Chief Warden, Jerome.

## ARKANSAS DIVISION

W. R. Blockson, Chief Warden, Eureka Springs.

## CALIFORNIA DIVISION.

Dr. David Starr Jordan, Chief Warden, Leland Stanford University.

## COLORADO DIVISION.

A. Whitehead, Chief Warden, 303 Tabor Building, Denver.

## CONNECTICUT DIVISION.

Hon. F. P. Sherwood, Chief Warden, Southport; Dr. H. L. Ross, Vice-Warden, Canaan; H. C. Went, Sec.-Treas., Bridgeport.

## DISTRICT OF COLUMBIA DIVISION.

C. H. Townsend, Chief Warden, U. S. Fish Commission.

## FLORIDA DIVISION.

W. W. K. Decker, Chief Warden, Tarpon Springs

## GEORGIA DIVISION.

J. J. Doughty, Chief Warden, Augusta.

## IDAHO DIVISION.

L. A. Kerr, Chief Warden, Kendrick

## ILLINOIS DIVISION.

M. D. Ewell, M.D., Chief Warden, 59 Clark St., Chicago; F. M. Taber, Vice Warden, 144 Kinzie St., Chicago; G. C. Davis, Sec.-Treas., 123 S. Central Ave., Austin.

## INDIANA DIVISION.

Frank L. Littleton, Chief Warden, 30½ East Washington St., Indianapolis; J. J. Hildebrandt, Vice Warden, Logansport; T. J. Carter, Sec.-Treas., State House, Indianapolis.

## IOWA DIVISION.

Carl Quimby, Chief Warden, Des Moines; C. C. Proper, Sec.-Treas., Des Moines.

## KANSAS DIVISION.

O. B. Stocker, Chief Warden, Wichita; A. J. Applegate, Sec.-Treas., 113 E. 1st St., Wichita

## KENTUCKY DIVISION.

Geo. C. Long, Chief Warden, Hopkinsville.

R. L. Brashear, Sec.-Treas., Bowling Green.

## MAINE DIVISION.

Col. E. C. Farrington, Chief Warden, Augusta.

## MARYLAND DIVISION

J. E. Tylor, Chief Warden, Baltimore.

## MASSACHUSETTS DIVISION.

Heman S. Fay, Chief Warden, Hazleton Block, Marlboro; J. E. Tweedy, Vice-Warden, North Attleboro; A. C. Lamson, Sec.-Treas., 194 Main St., Marlboro.

## MICHIGAN DIVISION.

J. Elmer Pratt, Chief Warden, Grand Rapids; R. S.

Woodliffe, Vice-Warden, Jackson; A. B. Richmond, Sec.-Treas., Grand Rapids.

## MINNESOTA DIVISION.

Dietrich Lange, Chief Warden, 2294 Commonwealth Ave., St Paul.

H. A. Morgan, Vice-Warden, Albert Lea; Prof. O. T. Denny, Sec.-Treas., St. Paul.

## MISSOURI DIVISION.

Bryan Snyder, Chief Warden, 726 Central Bldg., St. Louis.

## MONTANA DIVISION.

Professor M. J. Elrod, Chief Warden, Missoula; Sidney M. Logan, Vice-Warden, Kalispell; R. A. Waagner, Sec.-Treas., Bozeman.

## NEBRASKA DIVISION.

Fred. E. Mockett, Chief Warden, Lincoln; P. O'Mahony, Sec.-Treas., Lincoln.

## NEVADA DIVISION.

Dr. W. H. Cavell, Chief Warden, Carson.

Geo. W. Cowing, Sec.-Treas., Carson.

## NEW HAMPSHIRE DIVISION.

Dr. A. F. Barrett, Sentinel Bldg., Keene, Sidney Conant, Sec.-Treas., Keene.

## NEW JERSEY DIVISION.

Percy Johnson, Chief Warden, Bloomfield; Dr. W. S. Colfax, Vice-Warden, Pompton Lakes; I. V. Dorland, Sec.-Treas., Arlington.

## NEW MEXICO DIVISION.

W. M. Borrowdale, Chief Warden, Magdalena.

## NEW YORK DIVISION.

John R. Fanning, Chief Warden, Powers' Bldg., Rochester; Col. R. E. Moss, Vice-Warden, Wallack's Theatre, New York City; Dr. C. C. Curtis, Sec.-Treas., Columbia College, New York City.

## NORTH DAKOTA DIVISION.

Dr. W. D. Jones, Chief Warden, Devil's Lake.

## OHIO DIVISION.

W. E. Gleason, Chief Warden, Mitchell Bldg., Cincinnati; A. C. Thatcher, Vice-Warden, Urbana.

## OKLAHOMA DIVISION.

W. M. Grant, Chief Warden, Oklahoma City.

## ONTARIO DIVISION.

C. A. Hammond, Chief Warden, Box 701, St. Thomas; D. L. Mells, Sec.-Treas., St. Thomas.

## OREGON DIVISION.

Robert F. Kelly, Chief Warden, Box 188, The Dalles; C. B. Cushing, Sec.-Treas., The Dalles.

## PENNSYLVANIA DIVISION.

C. F. Emerson, Chief Warden, 189 N. Perry St., Titusville; Hon. C. B. Penrose, Vice-Warden, 1720 Spruce St., Philadelphia; E. Wager-Smith, Sec.-Treas., 1026 Ridge Ave., Philadelphia.

## RHODE ISLAND DIVISION.

Zenas W. Bliss, Chief Warden, 49 Westminster St., Providence.

## SOUTH CAROLINA DIVISION.

C. F. Dill, Chief Warden, Greenville.

## SOUTH DAKOTA DIVISION.

D. C. Booth, Chief Warden, Spearfish; John C. Barber, Sec.-Treas., Lead.

## TENNESSEE DIVISION.

Hon. G. C. Martin, Chief Warden, Clarksville; Hon. Austin Peay, Jr., Sec.-Treas., Clarksville.

## TEXAS DIVISION.

Prof. S. W. Stanfield, Chief Warden, San Marcos; W. E. Heald, Sec.-Treas., San Angelo.

## UTAH DIVISION.

Hon. John Sharp, Chief Warden, Salt Lake City.

## VERMONT DIVISION.

W. E. Mack, Chief Warden, Woodstock; S. C. White, Sec.-Treas., Woodstock.

## VIRGINIA DIVISION.

R. G. Bickford, Chief Warden, Newport News. C. O. Saville, Vice Warden, Richmond; M. D. Hart, Sec.-Treas., 1217 East Main St., Richmond.

## WASHINGTON DIVISION.

F. S. Merrill, Chief Warden, Spokane; F. A. Pontius, Sec.-Treas., Seattle; Munro Wyckoff, Vice-Warden, Pt. Townsend.

WEST VIRGINIA DIVISION.

E. F. Smith, Chief Warden, Hinton,  
WISCONSIN DIVISION.

Frank Kaufman, Chief Warden, Two Rivers; Dr.  
A. Gropper, Sec.-Treas., Milwaukee.

WYOMING DIVISION.

H. E. Wadsworth, Chief Warden, Lander; Frank  
Bond, Sec.-Treas., Cheyenne.

*Applications for membership and orders for badges  
should be addressed to Arthur F. Rice, Secretary, 23 W.  
St., New York.*

LOCAL WARDENS IN NEW YORK.

County.	Name of Warden.	Address.
New York,	Conrad L. Meyer,	46 W. Broadway.
Livingston	M. De La Vergne,	Lakeville.
"	K. S. Chamberlain,	Mt. Morris.
"	Henry Skinner,	Springwater.
"	Dr. J. W. Cowan,	Geneseo.
Albany,	C. D. Johnson,	Newtonville.
"	Kenneth E. Bender,	Albany.
Broome,	John Sullivan,	Sanitaria Springs
"	R. R. Mathewson,	Binghamton.
Cayuga,	H. M. Haskell,	Weedsport.
Chemung,	Fred. Uhle,	Hendy Creek,
"	M. A. Baker,	Elmira.
Cortland,	James Edwards,	Cortland.
Erie,	E. P. Dorr,	103 D. S. Morgan Building, Buffalo.
"	Marvin H. Butler,	Mórilla.
Essex,	W. H. Broughton,	Moriah.
Franklin,	Jas. Eccles,	St. Regis Falls.
Montgomery,	Charles W Scharf,	Canajoharie.
Oneida,	J. M. Scoville,	Clinton.
Orange,	Wilson Crans,	Middletown.
"	J. Hampton Kidd,	Newburgh.
"	Thomas Harris,	Port Jervis.
Richmond,	Lewis Morris,	Port Richmond.
St. Lawrence,	Dr. B. W. Severance,	Gouverneur.
"	A. N. Clark,	Sevey.
Schenectady,	J. W. Furnside,	Schenectady.
Suffolk,	F. J. Fellows,	Central Islip, L. I.
"	P. F. Tabor,	Orient, L. I.
Tioga,	Geo. Wood,	Owego.
Washington,	C. L. Allen,	Sandy Hill.
"	A. S. Temple,	Whitehall.
"	J. E. Barber,	Dresden.
Westchester,	George Poth,	Pleasantville.
"	Chas. Seacor,	57 Pelham Road, New Rochelle.
"	M. W. Smith,	Croton Falls.
"	Ralph Gorham,	Mt. Kisco
Dutchess,	A. B. Miller,	Jackson's Corners,
Columbia,	James Lush,	Memphis.
Onondaga,	B. L. Wren,	Penn Yan.
Yates,	Symour Poiner,	Branch Port.
"	Chas. H. DeLong,	Pawling.
Dutchess,	Jacob Tompkins,	Billings.
Queens,	Gerard Van Nostrand,	Flushing, L. I.
"	W. S. Mygrant,	46 Elton Street, Brooklyn.
"	P. A. Geepel,	473 Grand Ave., Astoria, L. I.
"	L. B. Drowne,	119 Somers Street, Brooklyn.
Ulster,	M. A. DeVall,	The Corners.
"	Wm. S. Mead,	Woodstock.
Jefferson,	C. J. Smith,	Watertown.
Herkimer,	D. F. Sperry,	Old Forge.
Oswego,	J. E. Manning,	154 West Utica St.
Putnam,	H. L. Brady,	Mahopac Falls.
Schuyler,	G. C. Fordham,	Watkins.
Allegany,	G. A. Thomas,	Belvidere.
Schoharie,	O. E. Eigen,	Sharon Springs.
Warren,	Geo. McEchron,	Glen Falls.
Orleans,	J. H. Fearby,	E. Shelby.
Greene,	W. J. Soper,	Windham.
Hamilton,	David Aird, Jr.,	Lake Pleasant.

LOCAL WARDENS IN OHIO.

Stark,	A. Dangeleisen,	Massillon.
Franklin,	Brook L. Terry,	208 Woodward Av., Columbus.
Cuyahoga,	A. W. Hitch,	161 Osborn St., Cleveland.
Clark,	Fred C. Ross,	169 W. Main St., Springfield.
Erie,	David Sutton,	418 Jackson St., Sandusky.
Fulton,	L. C. Berry,	Swanton.
Allen,	S. W. Knisely,	Lima.

County.	Name of Warden.	Address.
Hamilton,	W. C. Rippey,	4465 Eastern Ave., Cincinnati.
Knox,	Grant Phillips,	Mt. Vernon.
Lorain,	T. J. Bates,	Elyria.
Ottawa,	Frank B. Shirley,	Lakeside.
Muskingum,	Frank D. Abell,	Zanesville.
Scioto,	J. F. Kelley,	Portsmouth.

LOCAL WARDENS IN CONNECTICUT.

Fairfield,	George B. Bliss.	2 Park Row, Stam- ford, Ct.
"	Harvey C. Went,	11 Park St., Bridge- port, Ct.
Fairfield,	Samuel Waklee,	Box 373, Stratford.
Litchfield,	Dr. H. L. Ross,	P. O. Box 100, Can- naan, Ct.
Middlesex,	Sandford Brainerd,	Ivoryton.
New Haven,	Wilbur E. Beach,	318 Chapel Street, New Haven Ct.
"	D. J. Ryan,	188 Elizabeth St., Derby.

LOCAL WARDENS IN MASSACHUSETTS.

Norfolk,	Orlando McKenzie,	Norfolk.
"	J. J. Blick,	Wrentham.
"	S. W. Fuller,	East Milton.
Suffolk,	Capt. W. J. Stone.	4 Tremont Row, Boston.
Worcester,	B. H. Mosher,	Athol.

LOCAL WARDENS IN NEW JERSEY.

Mercer.	Edw. Vanderbilt,	Dentzville, Trenton.
"	Roland Mitchell,	739 Centre St., Trenton.
"	F. C. Wright,	Trenton.
Morris,	Joseph Pellet,	Pompton Plains.
"	Chas. W. Blake,	Dover.
"	Francis E. Cook,	Butler.
"	Calone Orr,	Hibernia.
Somerset,	G. E. Morris,	Somerville.
Sussex,	Isaac D. Williams,	Branchville.
Union,	A. H. Miller,	Cranford.
"	C. M. Hawkins,	Roselle.
Warren,	{ Jacob Young,	{ Phillipsburg.
Monmouth,	{ Reuben Warner,	{ Wanaque.
Hudson,	Dory-Hunt,	51 Newark St., Hoboken
"	A. W. Letts,	

LOCAL WARDENS IN PENNSYLVANIA.

Jefferson,	John Noll,	Sykesville.
Perry,	Samuel Sundry,	Lebo.
Warren.	F. P. Sweet,	Goodwill Hill.
"	Nelson Holmes,	Cornplanter.
Juniata,	Clifford Singer,	Oakland Mills.
"	Ezra Phillips,	McAlesterville.
Wenango,	G. D. Benedict,	Pleasantville.
Potter,	Ira Murphy,	Coudersport.
"	Wiley Barrows,	Austin.
"	Chas. Barrows,	Austin.
Crawford,	Jasper Tillotson,	Tillotson.
"	Geo. T. Meyers,	Titusville.
"	J. B. Lamb,	Buel.
Cambria,	W. H. Lambert,	720 Coleman Ave., Johnstown.
Butler,	F. J. Forquer,	Murrinsville.
Allegheny,	S. H. Allen,	Natrona.
Beaver,	N. H. Covert,	Beaver Falls.
"	W. R. Keefer,	"
McKean,	C. A. Duke,	Duke Center.
"	L. P. Fessenden,	Granere.
"	Wm. Holsinger,	Stickney.
Lackawanna,	Wm. Weir,	Moosic.
"	Wm. Major,	"
Carbon,	Asa D. Hontz,	East Mauch Chunk.
Cumberland,	J. C. Gill,	Mechanicsburg.
Wyoming,	Cyrus Walter,	Tunkhannock.
Tioga,	E. B. Beaumont, Jr.,	Lawrenceville.
"	G. H. Simmons,	Westfield.
Lycoming,	Jas. J. Brennan,	Oval.
"	B. D. Kurtz,	Cammal.
Delaware,	Walter Lussou,	Ardmore.
Montgomery,	L. C. Parsons,	Academy.
Bradford,	Geo. B. Loop,	Sayre.
Clarion,	Isaac Keener,	New Bethlehem.
Cameron,	Harry Hemphill,	Emporium.
Clinton,	M. C. Kepler,	Renovo.
"	Geo. L. Kepler,	Renovo.
Northumber-land,	{ G. W. Roher,	{ 505 Anthracite St., Shamokin
Elk,	{ D. R. Lobaugh,	{ Ridgway.
Fayette,	Ely Cope,	Cadwallader.

LOCAL WARDENS IN MICHIGAN.

County.	Name of Warden.	Address.
Ottawa,	W. H. Dunham,	Drenthe.
Kalamazoo,	C. E. Miller,	Augusta.
Berrien,	W. A. Palmer,	Buchanan.
Cass,	Thomas Dewey,	Dowagiac.
Hillsdale,	C. A. Stone,	Hillsdale.
Lake,	John Trieber,	Peacock.

LOCAL WARDENS IN VIRGINIA.

Mecklenburg,	J. H. Ogburn,	South Hil.
King William,	N. H. Montague,	Palls.
Smythe,	J. M. Hughes,	Chatham Hill.
King & Queen,	R. D. Bates,	Newtown.
Louisa,	J. P. Harris,	Applegrove.
Henrico,	W. J. Lynham,	412 W. Marshall.
East Rockingham,	E. J. Carickhoff,	Richmond.
		Harrisonburg.

LOCAL WARDENS IN WYOMING.

Fremont,	Nelson Yarnall,	Dubois.
Uinta,	{ S. N. Leek,	} Jackson.
	{ F. L. Peterson,	
Carbon,	Kirk Dyer,	Medicine Bcw.
Laramie,	Martin Breither,	Cheyenne.

LOCAL WARDENS IN TENNESSEE.

Sumner,	W. G. Harris,	Gallatin.
Stewart,	John H. Lory,	Bear Spring.
Robertson,	C. C. Bell,	Springfield.
Montgomery,	P. W. Humphrey,	Clarksville.
Madison,	H. T. Rushing,	Jackson.

LOCAL WARDENS IN NEBRASKA.

Hall,	E. C. Statler,	Grand Island
-------	----------------	--------------

LOCAL WARDENS IN NEW HAMPSHIRE.

Cheshire,	S. C. Ellis,	Keene.
Sullivan,	G. A. Blake,	Lempster.
"	J. W. Davidson,	Charlestown.

LOCAL WARDENS IN VERMONT.

Rutland,	Wm. J. Liddle,	Box 281, Fair Haven
Windsor,	F. A. Tarbell,	West Bridgewater.
Orleans,	E. G. Moulton,	Derby Line.
Essex,	H. S. Lund,	Granby.

LOCAL WARDENS IN ILLINOIS.

Rock Island,	D. M. Slottard,	12th Ave and 17th
		St., Moline.
Iroquois,	J. L. Peacock,	Sheldon.

LOCAL WARDENS IN OKLAHOMA.

Kiowa and Comanche Nation,	A. C. Cooper,	Ft. Sill.
----------------------------	---------------	-----------

LOCAL WARDENS IN IOWA.

Clinton,	D. L. Pascol,	Grand Mound.
Pottawattamie,	Dr. C. Engel,	Crescent.

LOCAL WARDENS IN WASHINGTON.

Okanogan,	James West,	Methow.
Stevens Co.,	Jacob Martin,	Newport.

LOCAL WARDENS IN UTAH.

Washington,	S. C. Goddard,	New Harmony.
"	J. A. Thornton,	Pinto.

LOCAL WARDENS IN KANSAS.

Ness,	Frank Lake,	Ransom.
-------	-------------	---------

LOCAL CHAPTERS.

Albert Lea, Minn.,	H. A. Morgan,	Rear Warden.
Angelica, N. Y.,	C. A. Lathrop,	"
Augusta, Mont.,	H. Sherman,	"
Austrin, Minn.,	G. F. Baird,	"
Austin, Pa.,	W. S. Warner,	"
Boston, Mass.,	Capt. W. I. Stone,	"
Buffalo, N. Y.,	H. C. Gardiner,	"
Cammal, Pa.,	B. A. Ovenshire,	"
Champaign Co., O.,	Hy. F. MacCracken	"
	Urbana,	"
Charlestown, N. H.,	W. M. Buswell,	"
Cheyenne, Wyo.,	J. Hennessy,	"
Choteau, Mont.,	G. A. Gorham,	"
Cincinnati, Ohio,	B. W. Morris,	"
Coudersport, Pa.,	I. L. Murphy,	"
Cresco, Iowa,	J. L. Platt,	"
Davis, W. Va.,	J. Heltzen,	"
Dowagiac, Mich.,	W. F. Hoyt,	"
East Mauch Chunk, Pa.,	E. F. Pry,	"
Evansville, Ind.,	F. M. Gilbert,	"
Fontanet, Ind.,	W. H. Perry,	"
Ft. Wayne, Ind.,	W. L. Waltemarth	"
Great Falls, Mont.,	J. M. Gaunt,	"
Heron Lake, Minn.,	K. C. Buckeye,	"
Hollida ysb'g, Pa.,	T. J. Hemphill	"
Hopkinsville, Ky.,	Hunter Wood,	"
Indianapolis, Ind.,	Joseph E. Bell,	"
Jerome, Ariz.,	Dr. L. A. Hawkins,	"
Johnsonburg, Pa.,	W. J. Stebbins,	"
Kalispell, Mont.,	John Eakright,	"
Keene, N. H.,	F. P. Beedle,	"

Kingfisher, Okla.,	A. C. Ambrose,	Rear Warden.
Lake Co., Ind.,	Dr. R. C. Mackey,	"
Lawton, O. T.,	Marion Miller,	"
Lincoln, Neb.,	A. J. Sawyer	"
Logansport, Ind.,	E. B. McConnell,	"
Ludington, Mich.,	G. R. Cartier,	"
Mechanicsburg, Pa.,	Dr. J. H. Swartz,	"
Minturn, Colo.,	A. B. Walter,	"
Morgantown, W. Va.,	B. S. White,	"
New Albany, Ind.,	Dr. J. F. Weathers,	"
New Bethlehem, Pa.,	Isaac Keener,	"
Oklahoma City O. T.,	N. F. Gates,	"
Penn Yan, N. Y.,	Dr. H. R. Phillips,	"
Phillips, Wis.,	F. K. Randall,	"
Princeton, Ind.,	H. A. Yeager,	"
Reynoldsville, Pa.,	C. F. Hoffman,	"
Ridgway, Pa.,	T. J. Maxwell,	"
Rochester, N. H.,	Gustave Andreas,	"
" N. Y.,	C. H. McChesney	"
St. Paul, Minn.,	O. T. Denny,	"
St. Thomas, Ont.,	L. J. Hall,	"
Schenectady, N. Y.,	J. W. Furnside,	"
Seattle, Wash.,	M. Kelly,	"
Syracuse, N. Y.,	C. C. Truesdell,	"
Terre Haute, Ind.,	C. F. Thiede,	"
The Dalles, Ore.,	C. B. Cushing,	"
Walden, N. Y.,	J. W. Reid,	"
Wichita, Kas.,	Gerald Volk,	"
Winona, Minn.,	C. M. Morse,	"

DISCOUNTS TO LEAGUE MEMBERS.

The following firms have agreed to give members of the L. A. S. a discount of 2 per cent. to 10 per cent. on all goods bought of them. In ordering please give L. A. S. number:

Syracuse Arms Co., Syracuse, N. Y. Guns.  
 Davenport Fire Arms Co., Norwich, Conn. Shot guns, rifles.  
 Gundlach Optical Co., Rochester, N. Y. Photographic goods.  
 Blair Camera Co., Rochester, N. Y. Photographic goods.  
 James Acheson, Talbot St., St. Thomas, Ontario, Sporting goods.

LIFE MEMBERS OF THE LEAGUE.

W. D. Ellis, 136 W. 72d street, New York City.  
 A. F. Rice, 155 Pennington avenue, Passaic, N. J.  
 Dr. W. A. Valentine, 5 W. 35th street, New York City.  
 A. A. Anderson, 6 E. 38th street, New York City.  
 A. V. Fraser, 478 Greenwich street, New York City.  
 E. S. Towne, care National Blank Book Co., Holyoke, Mass.  
 F. G. Miller, 108 Clinton street, Defiance, Ohio.  
 Gen. J. F. Pierson, 20 W. 52d street, New York City.  
 E. T. Seton, 80 W. 40th street, New York City.  
 J. H. Seymour, 35 Wall street, New York City.  
 A. G. Nesbitt, Maple street, Kingston, Pa.  
 D. C. Beard, 204 Amity street, Flushing, L. I.  
 C. H. Ferry, 1720 Old Colony Bldg., Chicago, Ill.  
 Hon. Levi P. Morton, 681 5th avenue, New York City.  
 H. Williams, P. O. Box 156, Butte, Mont  
 D. B. Fearing, Newport, R. I.  
 E. H. Dickinson, Moosehead Lake Me.  
 Lorenzo Blackstone, Norwich, Corn.  
 A. L. Prescott, 90 W. Broadway, New York City.  
 G. S. Edgell, 192 Broadway, New York City.  
 W. B. Mershon, Saginaw, Mich.  
 Hon. H. W. Carey, East Lake, Mich.  
 George Carnegie, Fernandina, Fla.  
 Andrew Carnegie, 2nd, Fernandina, Fla.  
 Morris Carnegie, Fernandina, Fla.  
 W. L. Underwood, 52 Fulton street, Boston, Mass.  
 C. E. Butler, Jerome, Ariz.  
 Mansfield Ferry, 183 Lincoln Park, Boulevard, Chicago, Ill.  
 Austin Corbin, 192 Broadway, New York City.  
 J. Stanford Brown, 489 Fifth Ave., New York City.  
 W. H. Smith, Bryn Mawr, Pa.  
 E. B. Smith, Bourse Bldg., Philadelphia, Pa.  
 A. I. McClure, 158 State street, Albany, N. Y.  
 T. Walter Thompson, Times Bldg., New York City.  
 Clinton Gilbert, 2 Wall St., New York City.  
 E. J. Hudson, 33 East 35th St., Bayonne, N. J.

There are thousands of men in the United States who should be life members. Why don't they join? Will someone please take a club and waken them?

## TO LOUISIANA SPORTSMEN.

Here is a letter from a resident of your State, every word of which should be burned into your intellect so deeply that you can not forget it, until the slaughter and the traffic recounted in this letter shall be completely broken up.

I have made many appeals to all the sportsmen in your State to join this League and to assist in securing the enactment of such laws in your State as are needed and as already exist in a majority of the States of the Union. Few men in your State have answered these appeals in any way. Now I put before you an appeal for help which comes to me from one of your own citizens. While you have ignored all my entreaties, you should certainly be willing to heed this one.

I have sent Mr. Deimer a supply of printed matter explaining the nature and aims of the L. A. S., and am ready to send any quantity of this literature to anyone and to everyone in your State who will take it and use it. Are you not ready now to join the League of American Sportsmen, and to aid in its good work?

Let me hear from you.

G. O. Shields, PRESIDENT.

I have just been informed that some gentlemen in New Orleans are trying to get members enough in this State to start a division of the L. A. S., of which I am highly in favor. If ever a place needed the L. A. S. it is this State. We have deer and some bears and turkeys; any number of quails, ducks and geese by millions in the winter; but there are men here who make a business of hunting and shooting for the New Orleans market. I know one young man here who killed and marketed 1,800 ducks last winter, and many other market hunters who killed nearly that many. Market hunting is practiced all along the Southern Pacific railroad, but not quite so extensively as here. The man who buys the game of these hunters owns a large gasoline houseboat. In the fall he gets his crowd of hunters together, generally 8 to 16 in number, gets them in the houseboat and runs down to the duck marsh. They stay there all winter and slaughter all the birds they possibly can. The marketman buys everything they kill that is at all eatable. Generally he pays this scale of prices; mallards, 25 cents a pair; pintails, 20 cents a pair; teal and small ducks, 15 cents a pair; geese and brant, 40 cents a pair.

Will you kindly put me on the road where I can do the most good, for I should like to see this cruelty stopped.

I am and have been a regular reader of your valuable and highly esteemed RECREATION and I always look forward with pleasure to each issue.

W. C. Deimer, Jennings, La.

## LEAGUE NOTES.

John J. Hildebrandt, vice warden of the Indiana division of the L. A. S., who lives at Logansport, Ind., is making trouble for the fish pirates in that region. He has put up a large number of League posters along the Wabash and tributary streams, and in addition has had a cloth poster of his own printed, which reads as follows:

## NOTICE.

I hereby offer a reward of \$25 to the person giving information leading to the arrest and conviction of any person or persons who may dynamite fish in our rivers.—J. J. Hildebrandt, Warden of the League of American Sportsmen.

Hon. L. A. Kerr, of Kendrick, Idaho, chief warden of the Idaho division of this League, has been appointed deputy State game warden for his district, and will at once inaugurate a vigorous campaign against game and fish law violators. It would therefore be well for all such to fold their tents and move to some other and more healthful ground.

If I had to choose between RECREATION and 3 meals, I would go hungry a day. It is the cleanest and most honest magazine that I subscribe to. In fact, it has made me disgusted with some I take, and I have discontinued one of the lot. If the rest do not stop publishing fish and game hog stories, there will be more cutting. I have RECREATION from the first issue, and would not part with it for 4 times the price. Success go with you to the 100,000 mark and beyond.

D. W. W. Mann, New Bedford, Mass.

A Chicago firm prints this legend on its envelopes:

He who whispers down a well,  
About the goods he has to sell,  
Will never coin the shining dollars,  
Like him who climbs a tree and hollers.

While most of the leading magazines enter our house, RECREATION is the only one I read the whole of, even to the advertisements. There is something drawing about it that can not be resisted.

Horace W. Scandlin, Brooklyn, N. Y.

Client—I hope you will have those divorce papers soon.

Lawyer—What's the hurry?

Client—Oh, I want to get unmarried and settle down.

RECREATION is the best publication of its kind I ever read.

Wm. Bates, West Plains, Mo.

RECREATION is the only original sportsmen's magazine.

Ralph Willis, Brooklyn, N. Y.

## FORESTRY.

EDITED BY DR. B. E. FERNOW.

It takes 30 years to grow a tree and 30 minutes to cut it down and destroy it.

### RETROGRADE MOVEMENT.

June 17th the Trustees of Cornell University abandoned the trust placed in their hands by the State, of conducting a College of Forestry.

This unexpected, precipitate abandonment of a successful educational department was the result of the veto by the Governor of the usual annual appropriation of \$10,000 for the maintenance of the college, which appropriation the Legislature had made without any opposition. The Governor acted without previous notice and after the Legislature had adjourned. The responsibility of legislating this State institution out of existence falls, therefore, entirely on him; an arbitrary exercise of the veto power, which was probably not foreseen as possible when it was given.

Altogether, the friends of a rational forest policy for the State of New York have good reason to be dissatisfied with the lack of interest or the ill will on the part of the Executive, who, on the other hand, has always given a willing ear to legislation inimical to forestry interests.

Under Governor Black's administration there was hope of a sensible and definite forest policy for the State. The Forest Preserve Board was created, to establish the State Forest Preserve, which was in the end to comprise 3 million acres. Funds for its purchase were judiciously appropriated and spent; the Forest Commission was properly supported; and to prepare for an ultimate rational forest management a forestry school was endowed in Cornell University and a demonstration of forestry methods instituted in the Adirondacks. Under Governor Roosevelt all these agencies of a rational forest policy made further progress and were well supported.

What has Governor Odell done?

He has used his veto power to annul or restrict all these measures. The Forest Preserve Board still exists in name, to be sure, because the Legislature did not abolish it; but the Governor last year vetoed the appropriation for further purchases and this year the Forest Preserve Board did not dare to lift its diminished head and ask for recognition of its existence and objects.

We now learn from the newspapers that the New York Central Railroad contemplates buying tracts in the Adirondacks for tie timber; and the State will have to pay for it!

For the Forest Commission the Governor had a veto of an appropriation of \$6,000 for

reclamation of waste areas so auspiciously begun, a veto of an appropriation of \$2,000 for additional forest surveys, a veto of the salary of an assistant superintendent of forests; all retrograde movements. Last of all, the entire appropriation for the State College of Forestry at Cornell was cut off by him. This is perhaps the worst blow, for it not only touches the interest of forestry most keenly, but the honor of the State; for the State invited Cornell University to institute this school and there is a moral obligation arising for the State toward the University as well as of the University toward the public, which it has invited to prepare and send their sons to the study of this new profession.

Is not this little short of repudiation of a debt? Under such abuse of the veto power any State institution may cease to exist at the will of the Governor at a moment's notice. This was certainly not intended when the people gave the Governor that power, which was given to prevent "extravagant or obnoxious legislation."

What was the reason for this overruling of the expressed will of the Legislature, which had without dissenting voice voted the regular supplies for this State institution of 5 years' standing? Was the College unsuccessful? The records do not show it. The College was remarkably successful in numbers and results. It doubled in number every year from 4 in the first to 70 in the past year. Its graduates and a number of special students, and even undergraduates, have found ready and profitable employment in Federal, State and private employ. Indeed, in numbers, at least, this College was ahead of all the German and French forestry schools; and no fault has ever been found, nor criticism heard of the College as an educational institution of the highest order. What, then, is the reason this successful branch of education, in which the State of New York and Cornell University were the leaders, had to be so suddenly cut off?

The Governor did not attach a reason to his veto, as would appear proper, but the newspapers were inspired to supply it. The reason assigned is, that the College had been criticised by a legislative committee in its methods of conducting the demonstration in the Adirondacks as wrong from the standpoint of scientific forestry. Who are the judges? Is the wisdom of a legislative committee on professional methods and questions to be taken in preference to

that of a professional forester of the highest standing?

Inquiry into the methods pursued to bring about this report of the Committee, this action of the Governor and the attacks on the College and the University, preceding these, reveals an interesting situation. The money power of a set of aggrieved bankers, who did not like to have their hunting privileges curtailed by the operations of the College, private selfish interests and not public policy, are the background of this veto!

If the Trustees of Cornell University had caught the true spirit of the citizens of the State, they would not have yielded to the pressure, but would have gone on with dignity to carry out their part of the agreement, trusting to the justice of their position to have the matter righted when better counsels might prevail.

#### PRIVATE OR STATE FORESTRY?

In the face of the frightful havoc brought suddenly to the homes of thousands of our citizens throughout the Eastern States in the shape of millions of acres of devastated forest land, one stands aghast that such destructive forest fires, with all their ruinous consequences, are still a matter of possibility at the beginning of the 20th century.

For 2 decades or more a strong propaganda has been made for a more careful and conservative exploitation of the timber resources of the country through the application of scientific forestry rules, as adopted by other civilized nations. What has been accomplished?

Instead of the inauguration of a healthy forest policy, having as its foundation adequate protective measures, the very protection of invested capital, without which scientific forestry becomes a farce, we see the government, both federal and State, catering to the wants of a few influential and wealthy persons by assisting them to enrich themselves at the general public's expense in the management of their respective properties.

While the original intentions and aims of the Bureau of Forestry, at Washington, for instance, to disseminate general knowledge of the practical application of scientific forestry rules by giving free advice and doing private work gratis, may have been good and honest, there can be hardly any doubt that paternalism in the management of private forest lands by government officials has been and always will be an utter failure.

The policy pursued so far has had the deplorable effect of putting our citizens to sleep in the belief that the future welfare of their forest holdings and their proper development and management would be safe in the hands of government employees; as if private and government interests ever did run in the same channels.

Forestry in the United States will never amount to anything as long as the people will not awaken to the necessity of doing something themselves. Success of private forestry demands individual and independent exertion, without which it can not bring satisfactory returns to both employer and employee.

In many instances, such as the Whitney and Rockefeller tracts in the Adirondacks, hundreds of thousands of dollars could have been saved had private enterprise and exertion been given a chance.

The experiences just gone through are a grim awakening to the undeniable fact that private interests and private property are safest in the hands of responsible private persons instead of government employees.—Exchange.

#### THE HISTORICAL NOVEL AND TREES.

A decade ago the psychological novel enthralled us; recently it has been the judiciously advertised historical novel. The newspaper tales of the enormous editions of historical novels are by no means so fantastic as they may read. A list, carefully compiled from publishers' returns which are absolutely without reproach, shows that the sales of 9 recently published novels have reached astounding proportions. Of one book, over 400,000 copies have been sold. Another is in its 325th thousand. Less successful books have attained only a paltry sale of 100,000, while a few minor ones hardly exceed a disappointing 80,000.

Books are made of paper. Paper in turn is made of cellulose, of which the chief source of supply is timber. In order to describe the romantic career of a 17th century gentleman of the rapier, it is necessary to fell a few hundred trees. The publication of many narratives in which the exploits of other cavaliers are dwelt on, may therefore entail the destruction of a forest.

The 9 novels referred to had a total sale of over 1,600,000 copies. Since the average weight of each book sold was probably 20 ounces, a little calculation will prove that these 1,600,000 books contained approximately 2,000,000 pounds of paper. The average spruce tree yields a little less than half a cord of wood, which is equivalent to about 500 pounds of paper. In other words, these 9 novels swept away 4,000 trees, and they form but a small part of the fiction so eagerly read by the American public. Some books are worth more than 4,000 trees. What may be the tree value of the modern historical novel?—Exchange.

#### SEEDLINGS.

We appreciate highly your effort to create a public opinion in favor of preserving the remaining forests and wild game from total annihilation. The majority of the people believe in you, from the poorest farm laborer up to the millionaire. We should have immediately an efficient forest fire brigade, such as other countries have, to watch for fires in the forests, and to see that fires do not get beyond control. Such a fire brigade should consist of regularly enlisted men, armed with carbines and uniformed in khaki.

M. H. Cole, Wellsburg, N. Y.

An article in the February number of the *Indian Forester* on "Progress in the United States" opens with the following paragraph:

How is it that the States have made more moral progress in forestry as a cause in 10 years than India has made or will make in a century? There are various reasons, but the fundamental one is that the President, Congress, and an increasing section of the people mean forestry, whereas in India the progress of the department has been a continual struggle with the people, and often with the local authorities. The other important reason is that the people of the States are educated to conviction.

Stranger (in Kansas City)—I want to go from here to 7th street. Which is the quickest way to get there?

Native Boy—Go right there to the edge o' this street an' fall off, mister.—Chicago Tribune.

## PURE AND IMPURE FOODS.

*"What a Man Eats He Is."*

Edited by C. F. LANGWORTHY, PH.D.

Author of "On Citraconic, Itaconic and Mesaconic Acids," "Fish as Food," etc.

### DANGERS OF FLIES AND DUST.

The spread of disease by flies and dust, and the precautions which should be observed in picnic grounds, where large numbers of people gather during the summer, are noted in a recent number of the *Sanitarian*. The following statements occur:

"We now know that flies sometimes carry disease germs, and for that reason all foods and all eating stalls should be properly screened. Probably the protection to food afforded by glass cases and refrigerators is the only right way, for the little fruit flies will readily crawl through the meshes of ordinary screens.

"The water supply of picnic groves is usually fair, for the springs and streams supplying them are generally from a wild and virgin upland. The water should be examined from time to time by an expert, especially during the picnic season, and all the precautions should be taken which are so well known and recommended for public supplies elsewhere.

"Dust is another element to be considered, not only on account of its unpleasantness, but as a dangerous element in carrying certain spores, especially those of tuberculosis. Dust can be so readily kept down by sprinkling, and at so little expense, that we have a right to demand its elimination."

The danger of spreading disease by means of flies is not limited to picnic groves. It has been proved by experiment that these insects can carry typhoid germs, which they gather by crawling over infected material and feeding on it; and it is more than probable that other diseases are sometimes transmitted in the same way. All possible pains should be taken, therefore, to keep such insects away from food.

Dust is also dangerous. Fruits and other sticky foods are often kept in markets under conditions which are far from sanitary. The dust from the streets adheres to their surface, and common cleanliness should compel everyone to make sure that the food is properly washed before it is used, especially in the case of something which is to be eaten raw. Best of all would be measures which would insure the handling, selling, and marketing of these and all foods under sanitary conditions.

In regard to the dust nuisance, Dr. J. O. Cobb, of the United States Public Health and Marine Hospital Service, says:

"In many of our great cities we have societies for the prevention of cruelty to children and animals, for the suppression of unnecessary noise, etc., but as far as I

know, none that has attempted to reform the dust nuisance. New York and several other cities have tried various methods of street cleaning to ascertain which raised the least dust. Dividing one street up into sections, under certain individuals who are responsible to the inspectors, is the most effective method and the least objectionable. The individual broom method of sweeping up the droppings immediately does away with much use of water to sprinkle, and prevents the pulverizing and drying. Using the big street sweepers on wheels is altogether wrong, unless the street is kept constantly wet. Otherwise the act of sprinkling, followed immediately by the sweeper, will stir up a cloud of dust.

"Considering the dust raised by passing street cars, vehicles, horses and people, and the breathing of smoke and soot in cities like Pittsburg, Chicago and Cincinnati, it is little wonder that lung diseases comprise such a vast proportion of all our diseases and deaths. The pulmonary and bronchial lymph glands are essentially scavengers that stand guarding our bodies from bacterial invasion. They are pushed to their utmost capacity to perform this function; and to give them the extra burden of arresting the foreign matter inhaled in dust is disastrous. Removing the consumptive, early in his disease, to a locality nearly free from all kinds of dust, will give him the best chance of recovery, principally because we have relieved his bronchial glands of this extra burden and have left them free to combat and arrest the onslaught of the tubercle bacillus.

"Numerous experiments show that the number of bacteria in dust at the street level is many times greater than at the tops of high buildings; that the air in the city contains a much greater proportion than the air of the country; and the air of the mountains less than at the sea level. The dust of certain portions of a city will show a much greater bacterial content than other sections."

### MARKETING BEANS.

Commercial bean-growing in the United States had its beginning in Orleans county, New York, about 1839, and for many years this region was the chief source of the supply of dry beans found in the market. The present production in the State approaches 2,000,000 bushels a year. New York probably still produces more than any other State, though Michigan and California are close seconds.

When the beans are ripe and the crop is harvested, the whole plant is pulled. This was formerly done by hand, but now beans are harvested almost exclusively by machinery. After the beans are gathered and dried, they are stored in barns like hay, until a convenient time for threshing. According to J. L. Stone, of the Experiment Station at Cornell, the threshing is usually done by specially constructed machines much like the ordinary grain thresher, but some growers prefer the old fashioned flail, claiming that the saving in beans, which otherwise would be split, compensates for the slower work. Discolored and damaged beans, gravel and dirt of various sorts must be removed before the beans are ready for market. Much of this work can be done by machinery, but some of it must be accomplished by hand picking. All the beans sent to market by New York growers are hand picked, which means that practically every bean is perfect. The matter of preparing the crop for market is now almost exclusively in the hands of the bean dealers. At a large number of the railway stations in the bean growing sections are bean houses, usually the property of a local produce dealer who buys the crop of the locality. The farmer delivers his crop at the bean house, where it is sampled. The sample is weighed, picked, and weighed again to determine the loss by picking. The farmer is usually paid for the estimated quantity of picked beans which he delivers. At the bean houses the beans are run through special machines that remove much of the refuse and sometimes grade the beans according to size. The hand picking is usually done by women and girls. The work is wonderfully facilitated by a mechanical device which causes the beans, thinly spread on a movable canvas apron, to pass slowly in front of the picker, who has opportunity to see each bean and time to pick out the gravel and damaged beans. By means of a foot lever the operator controls the movement of the apron, and the rapidity of the flow of the beans, which are led by means of spouts from the storage room above. Some dealers arrange to work so as to keep 10 to 20 persons employed throughout the year.

The civil war, Professor Stone believes, was a potent factor in extending the use of dried beans as human food in the United States. In 1861 the government began to buy beans for use in the army, and during the civil war production increased rapidly. At the close of the war the government demand ceased, but the soldiers had learned to eat beans and they carried the habit back with them into home life and induced others to eat beans, also. Thus began the demand for beans that has made possible the great development of the industry.

Other causes have influenced the consumption of beans in certain localities, but none were of so widespread influence as the civil war. At the present time, the practice of canning beans in convenient and attractive forms is doing much to extend their use.

Other phases of bean growing are of considerable importance in New York, though not rivaling the dry bean industry. Near the cities and towns the market gardeners produce large quantities of vegetable or snap beans to be put on the markets in the green state. The canning factories consume large quantities of sugar beans, which nearly mature, but without drying are put up in cans as shell beans. In certain sections of the State considerable areas are devoted to growing the garden or vegetable varieties of beans for seedsmen.

#### LOBSTER FISHING IN CHILE.

In the opinion of the American Consul at Valparaiso, "the Island of Juan Fernandez, lying 600 miles West of Valparaiso, made famous by the story of Robinson Crusoe, promises soon to develop industrial interests. The island belongs to Chile, and that government is now arranging to make it a part of one of the Provinces and establish a local civil government. The island is about 15 miles long and 8 miles in width. There is a good harbor on one side, where large ships can anchor with safety.

"A large canning factory has been established in Juan Fernandez, and the fishing industries are attracting the attention of capitalists. There are quantities of lobsters, crabs and excellent food fishes in the waters. The lobsters are large, of excellent flavor, and especially suited for canning. They are easily caught, the supply seems inexhaustible, and the cost of securing them is nominal. There are also large numbers of fur seals on Fernandez and other islands near, the taking of which might be profitably added to the lobster and fish business. The laws of Chile permit the killing of seals from March 1 to November 1. There is a ready market for the seal skins in this port, whence they are shipped to Europe.

"There is plenty of fresh water on the island; land can be acquired by settlers without cost; fruit and vegetables grow wild and are easily cultivated, which makes the cost of living comparatively low."

---

"Let me sell you a letter opener," said the clerk in the novelty store.

"Have one at home," responded the little man.

"Indeed! What kind is it?"

"My wife."—Chicago News.



## PUBLISHER'S NOTES.

### IMPROVEMENTS IN THE SYRACUSE.

The new catalogue of the Syracuse Arms Company is now out and describes several changes in their guns. Among other things these people say:

We have placed through the extension rib a double wedge fast bolt instead of the single one as heretofore. We have let the stock into the frame in such a manner as to prevent spreading or splitting. We have changed the models of our stock materially, and are informed by the trade generally that we now have the most shapely stock of any American gun made. We are placing a full pistol grip on our grade No. 3 without any extra charge. Heretofore we have been charging \$2 list extra on this grade for full pistol grip.

We are settled in our new factory and are in better shape than ever to take care of our rapidly increasing trade. Our trade so far this year has trebled that of last. We have made our new plant thoroughly up to date.

The new automatic ejector that we are placing on our A and higher grades of guns, whereby the shooter is enabled to change from an automatic ejector to a non-ejector instantly, and that without the use of tools, seems to have met and filled a long felt want. We give an option of Krupp steel barrels in connection with automatic ejector, on an \$80 list gun, and are putting 16 gauge barrels on 16 gauge frames.

The following are a few of the recent testimonials to the Life Saving Folding Canvas Boat Company:

Dear Sirs:

I have tried the canvas boat, paddling 3 miles up a winding salt creek against tide and an East wind. She behaved well, and under more favorable conditions would have made a much better showing. Am perfectly satisfied.

Yours respectfully,

F. M. Savery.

With City Nat'l Bank, Brooklyn, N. Y.

Dear Sirs:

I received my boat and am much pleased with it.

Yours truly,

Jas. L. Gilfillan, Skowhegan, Me.

Messrs. Schoverling, Daly & Gales, New York, write me that a customer of theirs wishes to sell a prosperous, well established sporting goods business in one of the most enterprising cities of Pennsylvania, with a population of 38,000 in the

city and 75,000 in the county. Cash receipts \$11,000 to \$17,000 per annum. Stock well selected and in first class order, cost \$11,500. The business on the invoiced value of the stock, and nothing added for the good will. The reason for selling is that the owner has accepted a lucrative position which requires all his time and attention.

Don't forget to take a Wick Plug for your rifle or shot gun when you go for your hunting trip this fall. It will save you much time in the cleaning of your gun, and it may save you the price of the weapon. Any man who will buy a good gun and then run the risk of having it ruined by rust or pits is mighty foolish. Oiled Wick Plugs are absolute preventives of rust and pits. These plugs are made for the different calibers and gauges. Write the manufacturers, Hemm & Woodward, Sidney, Ohio, for circular, and please say you saw their ad in RECREATION.

Of the many stock companies in existence during the past few years the last formed and newest, Proctor's Big Stock Company, is the only one remaining. During the coming season the company will even surpass in general excellence that of last. For each production or revival new scenery and electrical embellishments are constructed. Mr. Proctor gives the public a chance to see for 15 to 75 cents productions fully equal to the \$2 performances given at other theatres.

The Southern Railway offers superb service to Asheville, Hot Springs and Brevard, N. C.

For descriptive literature on the Land of the Sky and the Sapphire Country address New York offices, 271 and 1185 Broadway. Alex. S. Thweatt, Eastern Passenger Agent.

At Parkersburg, W. Va., the individual championship of West Virginia was won by Dr. E. E. Sample, of Huntington, W. Va., breaking 48 out of 50, shooting 40 grains DuPont, 1¼ ounces 7½ chilled shot, 2¾ inch cases.

"The Summer Boarder," containing a list of 3,000 summer hotels and boarding houses on or reached by the New York Central lines, sent on receipt of a 2 cent stamp by G. H. Daniels, G. P. A., New York.

## EDITOR'S CORNER.

### A GREAT YEAR FOR GAME LAWS.

Last winter was the most eventful in the history of the game protective movement in this country. More was accomplished in the enactment of proper laws for the preservation of wild birds and animals than in any previous year in the history of the country.

Montana, Idaho, Wyoming, Oregon, Minnesota, Illinois, Tennessee, Virginia and Texas have completely reconstructed their game laws. Some of these States have repealed existing statutes for the protection of game and of song birds, and have enacted complete new codes, from beginning to end, built on thoroughly modern lines.

New York has lined up with Vermont, New Hampshire, Ohio, Michigan, Wisconsin, Minnesota, Utah, Alaska, Manitoba, Ontario, New Brunswick and Newfoundland in prohibiting the spring shooting of wild fowl.

Nebraska, Texas and Idaho have passed laws during the past winter prohibiting the killing of antelope at any time, thus leaving Wyoming and Washington the only States, having any antelope, in which these animals may be legally killed.

Arkansas has prohibited the sale of all kinds of game; Illinois that of wild fowl; Washington that of rail and plover, and of water fowl with certain reservations. New York has prohibited the sale of ruffed grouse and woodcock within the State.

Texas and Arkansas have cut off the export of wild fowl, and Indiana, Montana and Tennessee have established additional restrictions on the export of game. Hunting licenses have been established or increased in Illinois, Indiana, Montana, Tennessee and New Hampshire, and Arkansas now denies non-residents the privilege of hunting there at any time. Several States have fixed a limit as to the number of birds or animals that may be killed in a day or in a season, while others have decreased the numbers each man may be permitted to kill.

The friends of game protection may therefore justly feel gratified with the results of their work. The sweeping changes and improvements in the game laws are wholly due to the educational work carried on by the League of American Sportsmen, the Audobon societies, the American Ornithologist's union and RECREATION; and the same great wave of public sentiment on behalf of the wild birds and animals, which has enabled us to secure the enactment of good laws in so many States, will greatly aid us in enforcing the laws.

### GAME BELONGS TO THE STATE.

One Tom Marshall, of Keithsburg, Ill., and 2 Powers brothers, of Decatur, Ill., own a tract of marsh land at Crane lake, in that State, which is a natural resort of wild fowl in their migrations North and South. These 3 alleged sportsmen sent a man to their preserve last summer with instructions to begin dumping corn and other grain about the blinds as soon as the ducks began to come in from the North. This order was carried out and the scheme succeeded so well that the 3 mighty duck butchers went to the marsh the opening day of the season and bagged 800 ducks, shipped them home and then followed the plunder to brag about it. This unparalleled act of slaughter aroused the ire of nearly every newspaper editor and every decent sportsman in Illinois. Then Marshall and the Powers brothers concluded they had made a mistake; not, perhaps, in slaughtering all the birds they could reach while feeding on the grain, but in boasting of it. So Chauncey M. Powers wrote a long article to a Western sportsman's journal, denying the charge of having killed 800 birds, claiming that they had only killed 500, and endeavoring to obviate the crime by saying they owned the land, that they had paid out a great deal of money for grain to bait it with, and so they had a right to kill the birds. This defense, however, does not stand. Migratory water fowl do not belong to the man on whose land they happen to alight for rest or feed, even though the owner of the land may pay out \$100 a day for corn to bait them with. The ducks belong to the people of the State, and the man who kills more than his reasonable share of them is a robber.

This brilliant piece of slaughter on the part of these 3 brutes has had a good effect on the people of the entire State of Illinois, and the result will probably be that a law will be enacted by the Legislature of that State in the near future, limiting the number of ducks which any one man may kill in a day to 25. The law should also provide a severe penalty for any man who shoots a wild fowl on or near any piece of land or water where feed has been placed to attract the birds.

### GOVERNOR ODELL CHANGES.

Governor Odell has changed his attitude materially on the subject of game protection. This is probably because he heard something drop, last fall. As I have before stated, he was elected Governor of New York in 1898 by a majority of 108,000 and



# Schlitz

**We Could  
brew beer  
for half  
our cost**

We could cut down half on materials.

We could save what we spend on cleanliness.

We could cease filtering our air.

We could send out the beer without aging it for months — but the beer would then cause biliousness.

We could save what it costs to sterilize every bottle — an expensive process.

**Yet You  
would pay  
the same**

Common beer — brewed without all our precautions — costs you no less than Schlitz Beer.

When you can get a pure beer — a healthful beer — at just the price of a poor beer, isn't it wise to ask for Schlitz?

**THE BEER  
THAT MADE  
MILWAUKEE  
FAMOUS.**

*Ask for the brewery bottling.*

re-elected in 1902 by a majority of 12,000. The difference is largely due to the fact that he vetoed the bill, which passed the Legislature in 1899, prohibiting the sale of ruffed grouse and woodcock; that he recommended the passage of a bill allowing the keeping of game in this State all through the year; and that he refused the League of American Sportsmen a hearing on that bill when it went before him for signature.

During last fall's political campaign Governor Odell learned that the League of American Sportsmen is a power in the land, so he has approved our bill prohibiting the sale of ruffed grouse and woodcock, which was again put through the Legislature. Not only this, but he sent a special message to the Assembly asking that body to pass Senator Brown's anti-spring duck shooting bill, which had previously passed the Senate. The Assembly passed this measure and the Governor promptly approved it. New York is now in line with a dozen other States of the Union which prohibit spring shooting of wild fowl.

The Governor can completely square himself with the sportsmen of this State by asking the next Legislature to repeal his nefarious cold storage bill; and not until that measure is wiped off the statute books will New York sportsmen in general support him for any public office.

A certain magazine printed in this city and devoted to outdoor sports, amateur photography, etc., in fact, a would be imitator of RECREATION, prints in its April issue a photograph which is labeled "Cow Moose, Millnocket Lake, Me." It shows dimly a bit of water and some driftwood in the foreground, and a wooded background. Just in front of the trees stand a poor, old, weary looking, domestic cow with horns, looking as if she were sorry she had ever been born. Her bony frame bespeaks a long absence from good pasture, and one is prompted on looking at the picture to wish he could offer her a bale of hay as a birthday present.

The text states that the picture was made by J. H. Fisher, Jr., of Baltimore, and that it was awarded 3d prize in a photo competition.

I know Mr. Fisher to be an honest, truthful man, and am sure he never attempted to palm off that picture on the editor of the aforesaid imitator as that of a cow moose. The alleged editor must have imagined that the cow moose ranging Millnocket lake have horns, high hip bones, sharp shoulder blades and ribs showing through; hence that the animal shown in this picture must be a cow moose. It would be well for this editor to take a walk through some good museum before he attempts to further instruct his readers about wild animals.

The Hon. H. S. Moran, member of the Texas Legislature from Parker county, is entitled to a great deal of the credit for

the enactment of the excellent game law which is now on the statute books of that State. He worked like a Trojan all through the session to secure the passage of this bill and was ably assisted by the Hon. Thomas Connally, of Marlin; Judge English, of Cameron; Wm. Pierson, of Greenville; J. R. Sanford, of Eagle Pass; L. S. Schluter, of Jefferson; H. B. Terrell, of West; and Seth P. Mills, of Waco. The sportsmen of the entire country are under deep obligations to these gentlemen for their untiring zeal in forcing this measure, and I am sure their efforts will be thoroughly appreciated by all friends of game protection.

Will Stewart E. White, who wrote me under date of March 23, regarding the slaughter of quails in Southern California, please send me his present address?

#### PRAYER OF THE PREDACEOUS.

Now this is the prayer of the Bull and Bear

At the shrine of the God of Gold,  
Where the shadows cast by a Christian  
spire

And the Westering sun's effulgent fire  
Down a narrow street unrolled:

"O Lord of the Merger and Trust and Pool,  
Of Gammon and Greed and Sham!  
'Man can not live by bread alone,'  
So, give us our daily lamb.

"We need his fleece to keep us warm,  
His fat when the nights are cool;  
And, after all, he's an only child  
And twin brother to a fool.

"We won't do a thing to the fresh young  
sheep  
But teach him to gambol and play;  
We'll feed him on only the best of 'shorts'  
And beautiful 'long' baled hay.

"He shall not suffer the pangs of thirst;  
This woolly stray from the flock;  
For innocence we love and prize,  
And always water our stock.

"The lion lies down with the lamb (inside),  
So why not the Bull and Bear?  
We'll show him 'cover,' we'll take him in,  
We've plenty of room to spare.

"His *mint* sauce let him bring with him;  
'The long green' that's nice with *game*;  
And he shall join our Browning club  
**And learn** what is in a name.

"Then, 'let us return to our mutton':  
With current funds (which is jam)  
He shall have a plunge in our deepest pool,  
And come out a steel spring lamb.

"O slightly Alloyed Auriferous God,  
Hear thy humble beasts who prey!  
The Knights of the Golden Fleece are we,  
And we worship thee night and day."

—W. E. P. French, in Life.

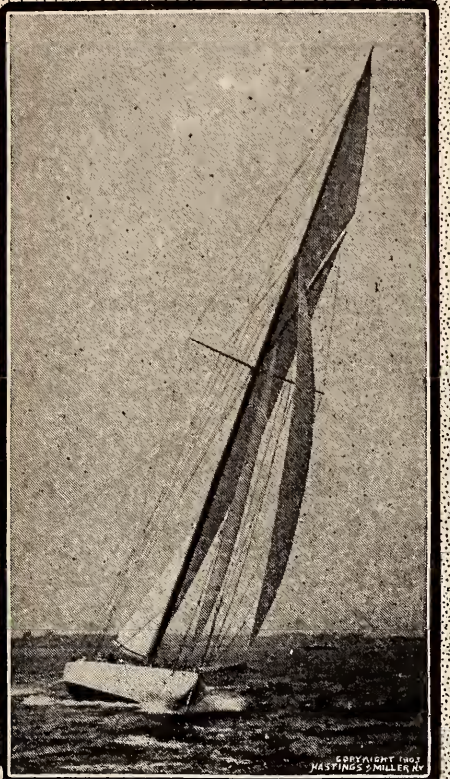

THE  
**EQUITABLE**

HENRY B. HYDE  
 FOUNDER

J.W.ALEXANDER  
 PRESIDENT



J.H.HYDE  
 VICE PRESIDENT

IN THE  
 RACE

of life there is no  
 greater handicap than worry.

An adequate Endowment  
 policy in the Equitable will  
 take from your life the two  
 great causes of worry—anxiety  
 about your own future—and  
 about the future of your family.

Vacancies in every State for men of energy and character to act as representatives

Apply to GAGE E. TARBELL, 2ND Vice President

For full information fill out this coupon, or write  
**THE EQUITABLE LIFE ASSURANCE SOCIETY of the United States.**  
 120 Broadway, New York Dept. No. 16

Please send me information regarding an Endowment for \$.....  
 if issued at.....years of age.  
 Name.....  
 Address.....

## AMATEUR PHOTOGRAPHY.

"For sport the lens is better than the gun."

*I wish to make this department of the utmost use to amateurs. I shall, therefore, be glad to answer any questions and to print any items sent me by practical amateurs relating to their experience in photography.*

## 8th ANNUAL COMPETITION.

RECREATION has conducted 7 amateur photographic competitions, all of which have been eminently successful. The 8th opened April 1st, 1903, and will close November 30th, 1903.

Following is a list of prizes to be awarded:

First prize: A Long Focus Korona Camera, 5 x 7, made by the Gundlach Optical Co., Rochester, N. Y., fitted with a Turner-Reich Anastigmat Lens, and listed at \$85.

Second prize: A No. 3 Folding Pocket Kodak, made by the Eastman Kodak Co., Rochester, N. Y., fitted with a Bausch & Lomb Lens, Plastigmat Unicum Shutter, and listed at \$61.50.

Third prize: A Royal Anastigmat Lens, 4 x 5, made by the Rochester Lens Co., Rochester, N. Y.; listed at \$36.

Fourth prize A Waterproof Wall Tent, 12 x 16, made by Abercrombie & Fitch, New York, and listed at \$32.

Fifth prize: An Al-Vista-Panoramic Camera, made by the Multiscope and Film Co., Burlington, Wis., and listed at \$30.

Sixth prize: A No. 3 Focusing Weno Hawkeye Camera, made by the Blair Camera Co., Rochester, N. Y., and listed at \$27.50.

Seventh prize: A high grade Fishing Reel, made by W. H. Talbot, Nevada, Mo., and listed at \$20.

Eighth prize: A Tourist Hawkeye Camera, 4 x 5, and made by the Blair Camera Co., Rochester, N. Y., and listed at \$15.

Ninth prize: A Bristol Steel Fishing Rod, made by the Horton Mfg. Co., Bristol, Conn., and listed at \$8.

Tenth prize: A pair of High Grade Skates, made by Barney & Berry, Springfield, Mass., and listed at \$6.

The 10 next best pictures will each be awarded one dozen 8 x 10 Carbutt Plates, made by the Carbutt Dry Plate Co., Wayne Junction, Philadelphia, Pa.

The 10 next best pictures will each be awarded one dozen 5 x 7 Carbutt Plates.

The 10 next best pictures will each be awarded one dozen 4 x 5 Carbutt Plates.

A special prize: A Goerz Binocular Field Glass, listed at \$74.25, will be given for the best picture of a live wild animal.

Subjects are limited to wild animals, birds, fishes, camp scenes, and to figures or groups of persons, or animals, representing in a truthful manner shooting, fishing, amateur photography, bicycling, sailing or other form of outdoor or indoor sport or recreation. Awards to be made by 3 judges, none of whom shall be competitors.

Conditions: Contestants must submit 2 mounted prints, either silver, bromide, platinum or carbon, of each subject, which, as well as the negative, shall become the property of RECREATION. Negatives not to be sent unless called for.

In submitting pictures, please write simply your full name and address on the back

of each, and number such prints as you may send, 1, 2, 3, etc. Then in a letter addressed Photographic Editor, RECREATION, say, for instance:

No. 1 is entitled — — —.

Made with a — — — camera.

— — — lens.

On a — — — plate.

Printed on — — — paper.

Length of exposure, — — —.

Then add any further information you may deem of interest to the judges, or to other amateur photographers. Same as to Nos. 2, 3, etc.

This is necessary in order to save postage. In all cases where more than the name and address of the sender and serial number of picture are written on the back of prints I am required to pay letter postage here. I have paid as high as \$2.50 on a single package of a dozen pictures, in addition to that prepaid by the sender, on account of too much writing on the prints.

Any number of subjects may be submitted.

Pictures that may have been published elsewhere, or that may have been entered in any other competition, not available. No entry fee charged.

*Don't let people who pose for you look at the camera. Occupy them in some other way.* Many otherwise fine pictures have failed to win in the former competitions because the makers did not heed this warning.

## PASSE-PARTOUT FRAMING.

R. S. KAUFMAN.

*Passe-partout* mounting of photographs, or any kind of pictures, is becoming more popular every day. This was shown at the exhibitions last winter. *Passe-partout* affords a cheap yet artistic means of protecting photographic work, as well as the many good illustrations found in the magazines of today. These can not be displayed to advantage without framing, and expensive frames often detract from the simplicity of the subject, whereas *passe-partout* merely adds to the simplicity.

In one sense, *passe-partout* is not a frame. It is simply a print mounted in the regular way, on any shade of mount, with a glass cover, and the whole held together by an edge binding, of linen or tough, pebbled paper. With the great number of shades of mounting papers now on the market, there is no end to the variety of tones and combinations to be obtained, to harmonize with the tone of the print to be framed. This simple method of framing will surprise and charm those who have not seen pictures thus mounted. A description of the process gives but a faint idea of the beautiful effects that may be obtained.

The best way to handle *passe-partouts*

is first to trim the print and mount it as desired. The size of the mount is important. Few pictures look well framed close,  $3\frac{1}{4} \times 4\frac{1}{4}$  and  $4 \times 5$  least of all. Ample margin often helps a picture, particularly if a broad and comprehensive view is contained in a small print. A wide margin conveys the idea of greater area. The double mounting now in vogue is particularly desirable for photographs, and whatever the tone of the print may be, a harmonious mounting can easily be made. A good method is to place a print on a suitably tinted mount, allowing a margin of  $\frac{1}{2}$  the width of the print. If the double mounting is preferred, use thin cover papers. Place the print face down on a clean piece of paper and apply a thick paste all around the edge. Then place the print on the mount and roll down. Trim the mount, allowing a margin of say  $\frac{1}{2}$  to  $\frac{5}{8}$  of an inch, and then mount on another shade, bearing in mind the harmonious combination of the whole. The blacks and many shades of gray are well adapted to the black toned prints of the platinum and developing paper varieties. Sepia prints are, of course, in harmony with the many shades of brown. As most of the mounting papers are thin, even with several thicknesses of mounting they must be mounted on a heavier board for a proper support.

After the print is properly mounted, secure a clean piece of glass, free from bubbles and other defects, and a piece of heavy cardboard. The glass and cardboard must be exactly the same size as the picture. In the cardboard make 2 small slits, or holes, and insert through them 2 small brass hangers, having flat ends like paper fasteners. These hangers can be bought for the purpose.

The binding of the 3 parts is next in order. Buy the ready prepared *passe-partout* binding, which can be procured in white, black, brown, green and red. The white, black and brown are always desirable; yet if none of these colors suits it is easy to use the white and tint it with water colors, as taste may dictate. The binding comes in rolls about 15 feet long and nearly an inch wide. Cut 2 strips the length of the plate, and allow one inch for each end to extend around the back. Two strips, allowing the extra length, are also required for the width. As the binding is already gummed, moisten it and apply it to the glass side of the picture, being careful that the binding laps evenly over the edge of the glass. It should lap about  $\frac{1}{8}$  inch on  $4 \times 5$ ,  $5 \times 7$  and  $6\frac{1}{2} \times 8\frac{1}{2}$  sizes, while on larger sizes it is better to lap  $\frac{1}{4}$  inch. Do not attempt to mitre the corners, but allow the binding to run to the end of the glass and around to the back. Paste the other strip running in the same direction. Then apply

the strips to the top and bottom in the same manner, the last 2 crossing at right angles the first 2.

After the binding has been placed in the right position on the glass, run the forefinger around the whole, to make the binding adhere firmly to the glass, and at the same time form a clean, sharp edge. The edges, where lapped over, should next receive attention. Turn the whole over on the table and rub the binding firmly down on the back. Treat the 4 sides in this manner, and trim off neatly any projecting ends at the corners.

If you frame your prints in this way your friends will appreciate your work more, and occasionally a sale of one's pretty bits is a result. Last but not least, your pictures serve the purpose for which they were intended, decoration. ○

#### PLATE AND DEVELOPER.

I use an Eastman plate camera, No. 4, with rapid rectilinear lens,  $4 \times 5$ . My work is chiefly landscapes, groups and other outdoor photography. What is the best brand of popular plates that give black and white negatives? What is the best developer for them? What speed is the best? I prefer fast plates. What is the best hypo for them? I use solio paper and solio toner and have lately had poor results with them. It has sometimes taken hours for them to tone to the desired color. When I first used them they worked well. I now use Smith's toner with solio paper and it gives good results. Is it a good brand and will solio paper toned with Smith's toner remain permanent for years? How can gloss prints be mounted so they will appear the same as when taken from the ferrotype plate, and remain so?

I wait for a dear friend when I wait for RECREATION.

Arthur E. S. Roth, Prairie du Chien, Wis.

#### ANSWER.

For the best results, use Carbutt plates or, if you wish superior results, use medium iso. They give the finest color values. Black and white negatives are under the control of the developer. Hydrochinone is noted for its contrast, metal for detail, and a combination of both work well on any plate. Pyrogallic acid developer is the best for any plate. Use plain hypo, made fresh, with the addition of a little alum. This may deposit on the film and must be swabbed off with a tuft of absorbent cotton before setting film aside to dry. The reason you do not get as good results with Solio as at first is that your toner is probably exhausted or too cold. Smith's toner, if a combined one, containing all the chemicals in one solution, will not make permanent prints on any paper. No combined toner will. Prints should be printed a little

darker than wanted, washed in clean water, handling over and over, changing the water when it becomes milky in color, and then toned in a bath of one grain of chloride of gold to 32 ounces of water. Make bath alkaline with 3 grains of bicarbonate of soda. Make this bath one hour before use. Tone to desired shade, but leave a little red in the shadows, as the prints dry darker. When toned place in one ounce of salt to one gallon of water. Then wash in fresh water several times and fix in fresh hypo, one ounce to 12 ounces of water.

Prints when taken from ferrotype plate should be placed face down on a clean surface, brushed with good paste without allowing print to shift in the least, then placed on card, covered with a clean blotter and rolled. This will allow them to dry without the loss of gloss.—EDITOR.

#### INDOOR PORTRAITS.

I am much interested in your amateur photography department, though I have only been taking pictures the last 4 months. I am living in a car on an Iowa railroad. It has 3 8 x 10 windows on the North and 3 on the South. I want to get pictures of the members of my family. If I take them outdoors they squint, and if I take them in the car their eyes do not show plainly. Can you tell me why?

What kind of printing out paper do you consider the best? I have tried Aristo self toning and Aristo platino, but have had no success at all. I like Solio and Velox the best of any I have tried.

Mrs. W. H. Stukeey, Carroll, Ia.

#### ANSWER.

In taking portraits indoors there are a number of difficulties to overcome, due in the majority of cases to the lack of space and to poor light. Place the subject about 4 feet from the window, toward the center of the room, and 2 feet from the window in the back. Have the chair slightly turned and facing the light. Place the camera on the side the window is on and as near the wall as possible. All the light available is thus thrown on subject.

Take portraits out of doors on the North side of the building, facing the North, camera pointing South, and take care that the sun does not shine into the lens. Any shady spot will do, but you can not take snapshots in such light. Give a short exposure and develop with a fresh developer diluted with water. Do not hold the camera when taking time exposures. Do not get too close to the subject with a fixed focus camera; 12 to 15 feet is about right. Solio or any printing out paper toned in a combined bath will fade. Try cyco.—EDITOR.

#### SNAP SHOTS.

A series of experiments in regard to washing negatives has been made by Herr Gaedicke. He finds that if the alum bath is used the hypo is much more difficult to get rid of, and several hours' washing is necessary, whereas half an hour is sufficient under ordinary circumstances. He recommends the use of a saturated solution of common salt in place of alum, if there is any tendency to frilling, which does not overharden the film, and does away with prolonged washing after fixation.

There is no reducer for bromides better than 15 minims of a saturated solution of iodine in alcohol, and 20 minims of saturated solution of potassium cyanide in water, diluted with half an ounce, or less, of water. For clearing a slight veil, dilute with an ounce of water, and immerse the print.

Wooden dishes may be made water-tight with the following preparation:

Common brown resin..... ½ pound  
Beeswax ..... 2 ounces

Melt together in tin pan; when fluid, run solution rapidly all over where required. Wood must be perfectly dry and warm.

I have been taking RECREATION for some years past, and especially enjoy reading the articles in the photographic department. I have a suggestion to offer other amateur photographers. After reading RECREATION I lift the ends of the binders with a knife and remove the pages on photography; then send the magazine to someone out in the back woods, that I have hunted or fished with. They enjoy reading the hunting stories, etc., but sometimes are not interested in photography. These pages I keep for future reference, and mark on the margin the month and year of the number from which they are taken. I find they come handy at times in hunting up formulas. I bind them together with a binder that I buy at a bookstore.

O. C. Hillard, Wilkes Barre, Pa.

A quick drying and easily removed backing for plates is made as follows: Put a cake of Newcomb's backing in an old tumbler or cup. Mix a solution of alcohol 4 parts, glacial acetic acid one part. Pour sufficient of this solution over the backing to coat the desired number of plates. Apply with a brush. The cup can then be set aside until wanted again, when more solution can be poured in and so on until it is used up. The backing can be wiped off with a damp cloth.

R. L. Wadhams, M. D.,  
Wilkes-Barre, Pa.



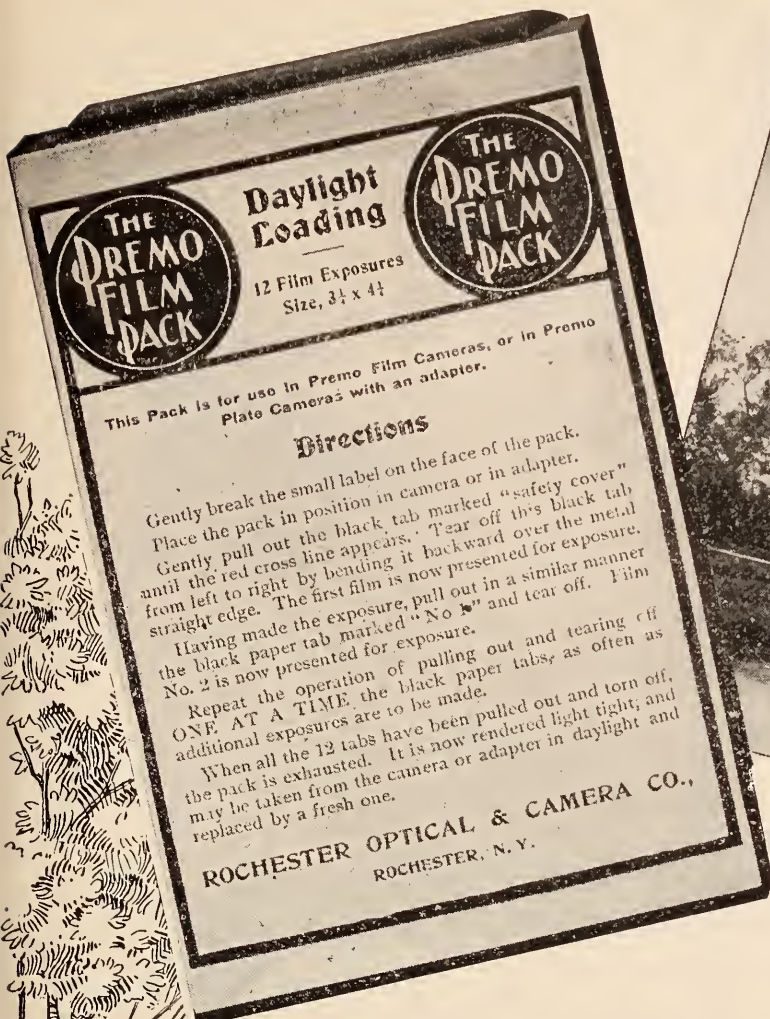

## The Pack and the Picture— A Very Simple Matter.

Amateur photographers have received the new PREMO Film Pack with almost extravagant praises. It meets the conditions of the outdoor picture maker as nothing else has ever done. Whether you use a PREMO Plate Camera or a PREMO Film Camera, it opens the easy way to photography;—a working outfit that is unequalled for simplicity and convenience.

# The PREMO Film Pack

## DAYLIGHT LOADING

As flat as a handkerchief in your pocket when not in use, as easy to load in daylight as shutting a book; it is unequalled for effectiveness. Carrying twelve non-curling, orthochromatic films; successive exposures are made by pulling out the numbered black paper tabs. The last tab seals the package light tight. Adapted to  $3\frac{1}{4} \times 4\frac{1}{4}$  and  $4 \times 5$  Cameras, the PREMO Film Pack meets successfully every photographic condition. See it at your dealer's or write for particulars contained in the *Premo Year Book*, free.

**ROCHESTER OPTICAL CO., Dept. 209, Rochester, N. Y.**

OBJECTS WELL CENTERED AND CORRECTLY FOCUSED

# The Focusing Weno Hawk- Eye

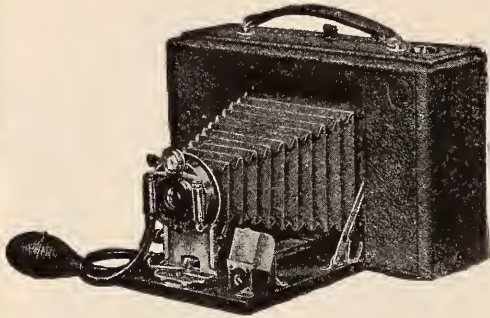

has the advantage  
over all cameras

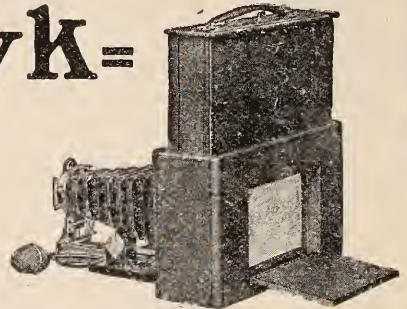

of a ground glass the size of picture, which works automatically and allows focusing when using film. The result is obvious—perfection of work—satisfaction to the user.

**No. 3 Focusing Weno Hawk-Eye, with B. & L. Automatic Shutter, and Extra Rapid Rectilinear Lens. Pictures  $3\frac{1}{4} \times 4\frac{1}{4}$ , " " " = \$27.50**

**No. 4 Focusing Weno Hawk-Eye, same equipment. Pictures  $4 \times 5$ , 30.00**

Hawk-Eye Film can be developed in the Kodak Developing Machine.

*Write for Hawk-Eye Booklet.*

**BLAIR CAMERA CO., Rochester, N. Y.**

## Do you want A Folding Canvas Boat?

IF SO, SEND ME

### 35 yearly subscriptions to RECREATION

AND I WILL SEND YOU

**A 14 ft. King folding canvas  
boat listed at \$48**

capable of carrying 2 men and an ordinary camp outfit. There are thousands of these boats in use, and nearly every man who is using one of them praises it on every occasion.

Sample copies of RECREATION for use in canvassing will be furnished on application.

**Address 23 W. 24th St., N. Y.**

**The Best Yet:**—To any person sending me \$2, express or money order, for one year's subscription to RECREATION, I will give free, one fine 3 joint bamboo rod, 7 to 9 feet long, one nickel plated 60 yard multiplying reel, and 50 yards of waterproof silk line. This outfit, including RECREATION, would cost \$6. Or I will give the above outfit for 7 yearly subscriptions to RECREATION. Or I will give the 50 yards of silk line, listed at \$1, for one subscription and 25 cents extra. This line is a very fine outfit and would retail in any store at \$1.

C. W. Jacobs, 339 N. 2nd St., Coshocton, O.

**Something Special — Playing Cards Free:**—To each person sending me \$1 for one year's subscription to RECREATION, or sending it direct to be placed to my credit, I will forward, all charges prepaid, a pack of elegant gold edge playing cards. These are no cheap second quality cards but first quality, of extra selected stock, highly enameled and polished, fancy set pattern backs, each pack wrapped in handsome glazed wrapper and packed in strong telescope case.

L. J. Tooley,

141 Burr Oak St., Kalamazoo, Mich.

RECREATION is the best all around magazine in the country.

Jas. L. Cravens, Pittsburg, Pa.

## SPOTTING OUT.

The question often arises at what stage it is best to put hand work into a photograph to take out spots or blemishes, or to modify its tones or details. The larger alterations, of course, must depend on the circumstances in each case, but for the mere spotting, definite rules can be laid down.

Pinholes may first be noted. The question whether or not they need to be removed must depend on their situation. If they are in the sky or in the high light of the picture, they may be so conspicuous as to be objectionable; but in the half tones or shadows they are certain not to be noticed, and should be left alone. In the former case, use a fine camel's hair brush and a little India ink. The ink must be fairly thick and black, but only the merest trace of it should be on the point of the brush, which should then be lightly touched on the pinholes. They should at once disappear. Deal in exactly the same way with larger clear spots, except that they are sure to need it, while pinholes, even when conspicuous on the negative, may often be left untouched. In like manner, scratches must be gone over. In each case the ink should be of sufficient strength for the spotting to show up quite white on the print.

Black spots need nothing at this stage. After working up the negative as directed all its defects show up as white spots or marks on the print. A white mark on the print can always be touched up with color so that it will match the tint of the parts around it; but a black spot on a print, such as is caused by clear glass on the negative, is a more difficult matter.

The final spotting has to be carried out, therefore, on the print itself. This is where many fail, yet when once the method has been grasped the whole thing is surprisingly easy. With glossy, burnished prints, it should be done after mounting and before burnishing. With prints dried on ferrotype or glass, it must be done after they leave that support. In this case a little gum mixed with the color will be found helpful. A great many of the spots will be found unnoticeable on the print if this has a matt or rough surface. Platinotype and carbon prints are especially easy to spot, using in the former case ivory black water color and in the latter a pigment made by dissolving a little unexposed tissue in warm water. The secret of success is to use the pigment weak and the brush *almost dry*, so that it only makes a faint mark on a sheet of white paper, except, of course, when the spots to be removed appear in the deep shadows.—Photography.

Sons of rich men all remind us  
Not to leave our sons a dime,  
Lest the sparks we leave behind us  
Burn our money and their time.  
—Exchange.



All of the dark-room fuss and bother is removed from photography by the

# Kodak

way of picture making. Better results than the old way too.

Anybody can make good pictures, now that the Kodak Developing Machine has abolished the Dark-Room.

**KODAKS, \$5.00 to \$75.00.**

**BROWNIES, \$1.00 and \$2.00.**

**KODAK  
DEVELOPING MACHINES,  
\$2.00 to \$10.00.**

**EASTMAN KODAK CO.  
ROCHESTER, N. Y.**

*Catalogue, free at the dealer's or by mail.*

# ALVISTA CAMERA



**T**AKES everything within half a circle, making a picture five inches high by twelve inches long; or you can stop the revolving lens at different points and make exposures either four inches long, or six inches, or ten, depending upon how much you want to get in the picture. No wasted film. The revolving lens moves at different speeds, so you can gauge your exposure accurately. The exposure of the film is on the same principle as the focal plane shutter for pictures of moving objects. Our catalogue tells of its many uses—free.

**MULTISCOPE & FILM CO., 136 Jefferson St., Burlington, Wis.**

# AL-VISTA PANORAMIC CAMERA



## THE HEIGHT OF ART in camera work

Perfection in photography, has been secured by the use of the Al-Vista Camera. It produces the entire panoramic view — **from the limit of vision on the left to the extreme point on the right.** The Al-Vista Camera is compact: easy to use, sure in action. It is sold on its merits: we demonstrate this by selling you one

## on easy payments

Ask us for a catalog: select the camera you wish, fill up the blank we shall send you, and references being satisfactory we will at once send you a camera—pay weekly or monthly in sums to suit your purse. The camera is no longer a luxury: the demands of modern progress make a good camera a necessity; we make it easy for you to get the best, an

## Al-Vista.

*The*

## Multiscope & Film Co.

136 Jefferson St.

Burlington, Wis., U. S. A.

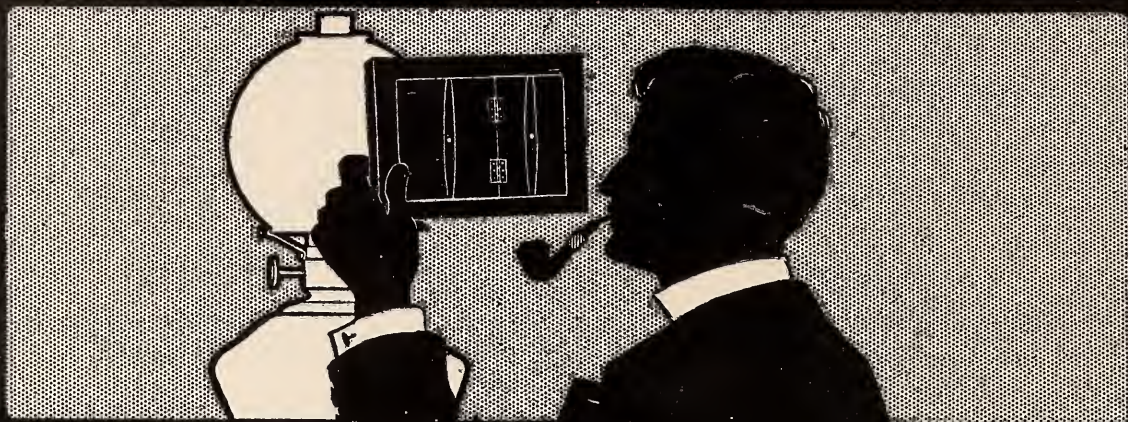

# VELOX

## Liquid Developer

Made especially for Velox by the Velox people—it makes Velox better than ever—and that is saying a great deal.

Four-ounce bottle Concentrated Solution, 25 cents.

ALL DEALERS.



THE LABEL.

NEPERA DIVISION,

EASTMAN KODAK CO.

ROCHESTER, N. Y.

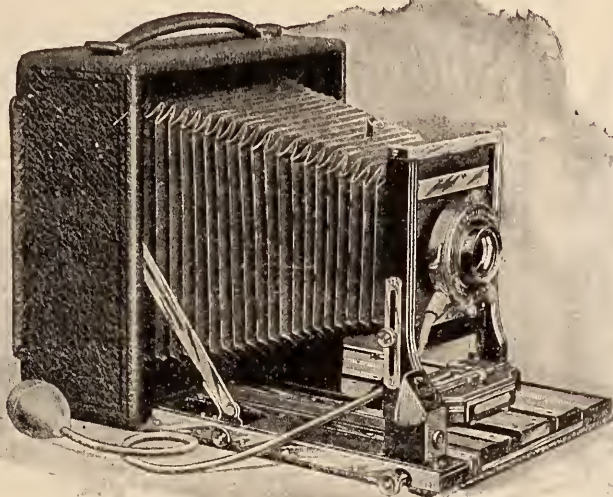

“In your Catalogue I notice you mention very often ‘Century Quality.’ I would like to state that I have found the excellent qualities of the Century Camera to be all you claim.

I have two Cameras besides the Century, BUT I WOULD NOT EXCHANGE MY CENTURY for a dozen like the other two, and either one of the others cost as much as the Century.”—*Extract from a Recent Purchaser's Letter.*

THE SUPERIORITY OF

# “Century” Cameras

Has won for them the highest praise from photographers everywhere.

**COMPARE** Centurys with other Cameras,  
**COMPARE** the general design,  
**COMPARE** the workmanship,  
**COMPARE** optical and mechanical features,  
**COMPARE** the ease of manipulation,  
**COMPARE** our many exclusive adjustments,  
**COMPARE** results.

Comparison makes the favorable comments regarding “*Century Quality*” still more numerous and emphatic.

Our new Catalogue describes Century Cameras in all styles, all sizes, at all prices. Ask your dealer for a copy or write the makers,

**Century Camera Co., Rochester, N. Y.**

# ROTOX

PRINTS IN ANY LIGHT

From each dozen sheets of ROTOX developing photo paper you can surely obtain twelve perfect prints. It prints from negatives too thin for other papers; is easier to manipulate and has a range of latitude that is unequalled.

## PLATINUM BLACKS

Prices, per dozen, thick or thin, rough or smooth: 4x5, 15 cents; 5x7, 30 cents; 6½x8½, 55 cents; 8x10, 70 cents.

"ROTOGRAPH," the best bromide paper, same prices.

Sample copy of the *Photo Critic*, containing, every month, articles on "The A to Z of Photography." Of interest to amateur and professional, sent FREE.

Subscription, \$1.00 per year. Write

ROTOGRAPH, Dept. V, 101 5th Ave., New York City



Do you want a Good, Reliable,  
Substantial, Well Made

## Single Barrel Shot Gun

If so, send me

10 YEARLY SUBSCRIPTIONS

and I will send you such a  
Gun as a premium

It is made by the *DAVENPORT ARMS CO.*, and this means it is made of good material and that only good workmanship is put on it.

This is one of the many remarkable opportunities *RECREATION* is offering to men and boys to fit themselves out completely for shooting and fishing.

Sample Copies for Use in Canvassing  
Furnished on Application.

Address

## RECREATION

23 W. 24th St., New York City

## Something New!

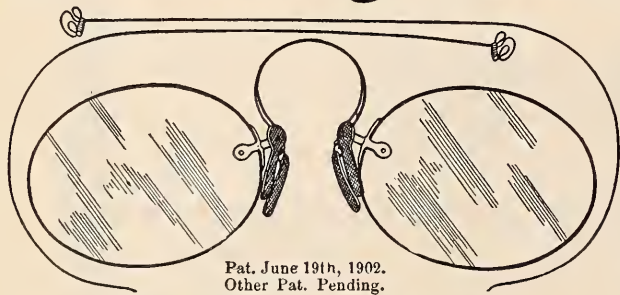

Pat. June 19th, 1902.  
Other Pat. Pending.

### PRESTO! CHANGE! Attachable Eyeglass Temples

Every wearer of eyeglasses wishes occasionally that they were spectacles. Spectacles stay on, however violent one's exercise, however warm or stormy the weather. This little device can be readily attached or detached without injury to the lenses, thus in a second giving you the choice of either spectacle or eyeglass. Just the thing for outdoor sports. The Temple Attachment will fit any of your eyeglasses and can be carried in the same case with them.

Send thickness of lens when ordering by mail.

Price in Nickel, 50 cents a pair  
Price in Gilt, 75 cents a pair.

Send for Circular.

Our illustrated catalogue can be had for the asking

We carry everything in the Optical and Photographic line Eyeglasses, Spectacles, Cameras, Opera, Field or Marine Glasses, Thermometers, Barometers, Telescopes, Hygrometers, Sun-dials, etc.

GALL & LEMBKE, Department C.

1 W. 42d Street 21 Union Sq., New York  
Established 1842.

## OIL PORTRAITS ON APPROVAL.

If you will send me a photo of yourself or a friend and state color of hair, eyes and complexion I will paint and send you on approval a miniature oil or pastel portrait.

Canvas 6x8 or 8x10 inches, \$10.00

Canvas 10x12 or 12x14 inches, \$15.00

Z. EMMONS, 58 West 104th St., New York.

Reference: Mr. G. O. Shields.

"Margaret, I think you cheapen yourself by going so much to the theater with Mr. Jones."

"No, mother; on the contrary, I'm making myself very dear."—Harvard Lampoon.

## LANTERN SLIDES COLORED SKILLFULLY AND ARTISTICALLY

FOR  
Lecturers, Teachers and others

I refer by permission to the Editor of RECREATION.

MRS. C. B. SMITH  
606 W. 115th Street, New York City



# ? RELIANCE? SHAMROCK?

Have you picked the Winner? Then you'll want to see her win. We can help you,—with the peerless

## TURNER-REICH BINOCULAR

When you pick your Winner among BINOCULARS, place your RELIANCE on the TURNER-REICH; it's no SHAM....



Write for Price List

GUNDLACH-MANHATTAN OPTICAL CO.  
730 So. Clinton Ave., Rochester, N. Y.

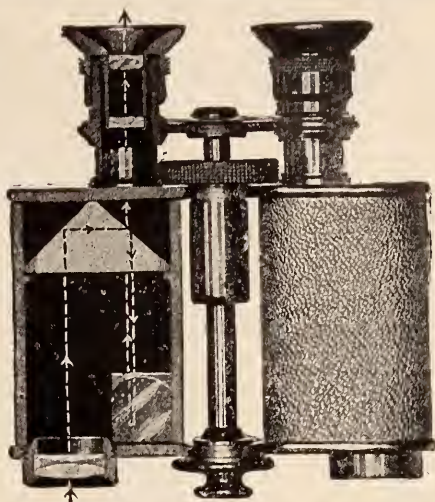

Size of yachts as seen with the unaided eye.

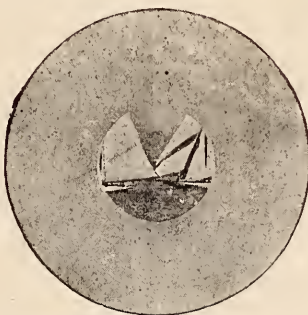

Field of the bulky old style 8-power Binocular



As seen with the 8-power Turner-Reich Binocular



### Made with The KORONA CAMERA

1884  
NINETEEN



1903  
YEARS'

Optical and Mechanical Experience  
is the HERITAGE of the  
**1903 KORONAS**

You cannot afford to buy a camera before you've seen and examined the new **KORONAS**.

You need an Anastigmat? We have two to offer:

The **TURNER-REICH** and the **VERASTIGMAT**

How about a Wide-Angle Lens in cells to fit your shutter? It's an **EMIL** you want.

**Gundlach-Manhattan Optical Co.**  
ROCHESTER, N. Y.

## GIVE THEM MARLINS.

JEAN ALLISON.

Sunday, December 8, 1901, Ralph D., a Verde river rancher, and I made arrangements to put in the few remaining days of the open season for deer on the Mogollon mountains. Monday, the 9th, we left his place in a spring wagon and drove as near to the rim as possible. From there we had to pack, and at 8 o'clock we landed on top of Secret mountain. The old Howard cabin was in a bad state of repair and the water in the tanks was low, so our prospects were flattering for a dry camp. Tuesday we looked for water and fresh deer signs, but found little of either. We concluded to move camp, and the following morning found us early on our way to Kelsey springs, on Sycamore creek, 12 miles Northwest. At noon we were on the Malipai rim, overlooking Sycamore creek and the noted Kelsey, or Black and Vail's, D. K. ranch. Down the rough and slippery trail we went, and were glad when we reached the bottom and were on the little flat where the house, corral and long string of 12 water troughs are situated.

We unpacked, watered our horses and hobbled them, found the key to the cabin, made ourselves comfortable, and soon had supper. By 8 o'clock we were dreaming of bucks with horns like rocking chairs and of the choice, juicy steaks and liver we were to enjoy.

By daylight Thursday we were wending our way over a frozen trail to Kastney mountain, about 2 miles distant. We had just crossed a little park and were rounding a rocky point when a jack rabbit jumped up, ran probably 40 feet and stopped. My companion wanted to shoot it, but I said no. We had not gone 20 steps when I spied a 3 point blacktail buck standing behind a fallen pine. Up went my 45-90 and down came the noble deer. After a number of hard trials we succeeded in hanging him high and dry. Cutting off his right ear as a trophy and tying up the liver we started for camp to get a pack horse to bring in our prize. When we reached from Maine, in a lumber camp near Williams. They were camped on the rim, 1/2 mile distant, and were down after water. They told us one member of their party had the misfortune to have his right hand torn off by the explosion of a 30-30 Marlin the week before.

When they had gone we looked for our horses and at sundown we cut their trail. They were heading up the slippery trail we came down the day before. The next morning we were out early and struck our horses' trail on top. We followed it a mile or so and then lost it. We made another circuit and Ralph jumped a spike buck and killed it. We hung the liver and heart on a twig and decided to go back that way to take them in for supper. After a futile search for many hours we gave up the horse hunt for the day and started for

home. When we came to our spike we found liver and heart gone and the tracks of 3 men and a dog. We grew suspicious from our loss and decided to pack our deer into camp. Saturday we devoted strictly to horse hunting. As we were nearing camp we decided to go to the place where we had packed our buck and lost the liver, to see if anything new had developed. Beneath the little oak on the black, soft ground were shod horse tracks and the 3 tracks of the liver thieves. Knowing our horses were lost they had thought we would leave the deer until we found them and that they would appropriate our spike. The loss of the liver to us was the loss of the deer to them. When we arrived in camp the party had gone.

Sunday morning, as we were rounding a cedar knoll, we ran on to a 4 year old bay mare, a 3-year old stallion and a 2-year old sorrel filly, all shot with 30-30 and 30-40 Winchesters, as we found the empty shells of those calibers. The chills ran over us at the sight and we recalled having heard 13 shots in that neighborhood Friday evening.

We located our horses on a far away point and by 11 o'clock were back in camp. Throwing a pack saddle on one of the horses we were soon on our way to the little knoll where our 3 point prize buck was hanging. When we reached there all that remained to tell the tale of the buck was the gambol stick, the blood-stained grass and an X, afterward put on the tree.

Brother hunters, think of the loss of the hot, juicy steaks we dreamed of, and do not blame me for registering a vow that if I learn the names of those thieves they will want no *crème de menthe* after I get through advertising them. The best way to get rid of such hunters would be to present each of them with a Paddy Marlin rifle and they could blow their bloomin' heads off. Then our bucks would hang where killed.

In speaking on the negro question the other night, Oscar R. Hundley, for many years a member of the Alabama Legislature, told a story to illustrate the workings of certain politicians. "I was out walking one spring," he said, "and saw sitting on the bank of a creek, fishing, an old, wizened negro and an uneasy little pickaninny. I watched them, until finally the little fellow wriggled off his log, going to the bottom of the creek. The old negro tossed off his coat, and, diving, grabbed the child, and drew him out. I said to him, 'Uncle, that was surely a magnanimous act; you must think a lot of the boy.'

"'Oh, no! mistah, you don't know 'Rastus. He's jes' the ornaries', triflines', shifless little cuss that evah was; but he had all the bait in his pocket.'"—New York Tribune.

IF YOU WOULD LIVE NEXT TO NATURE, READ RECREATION.

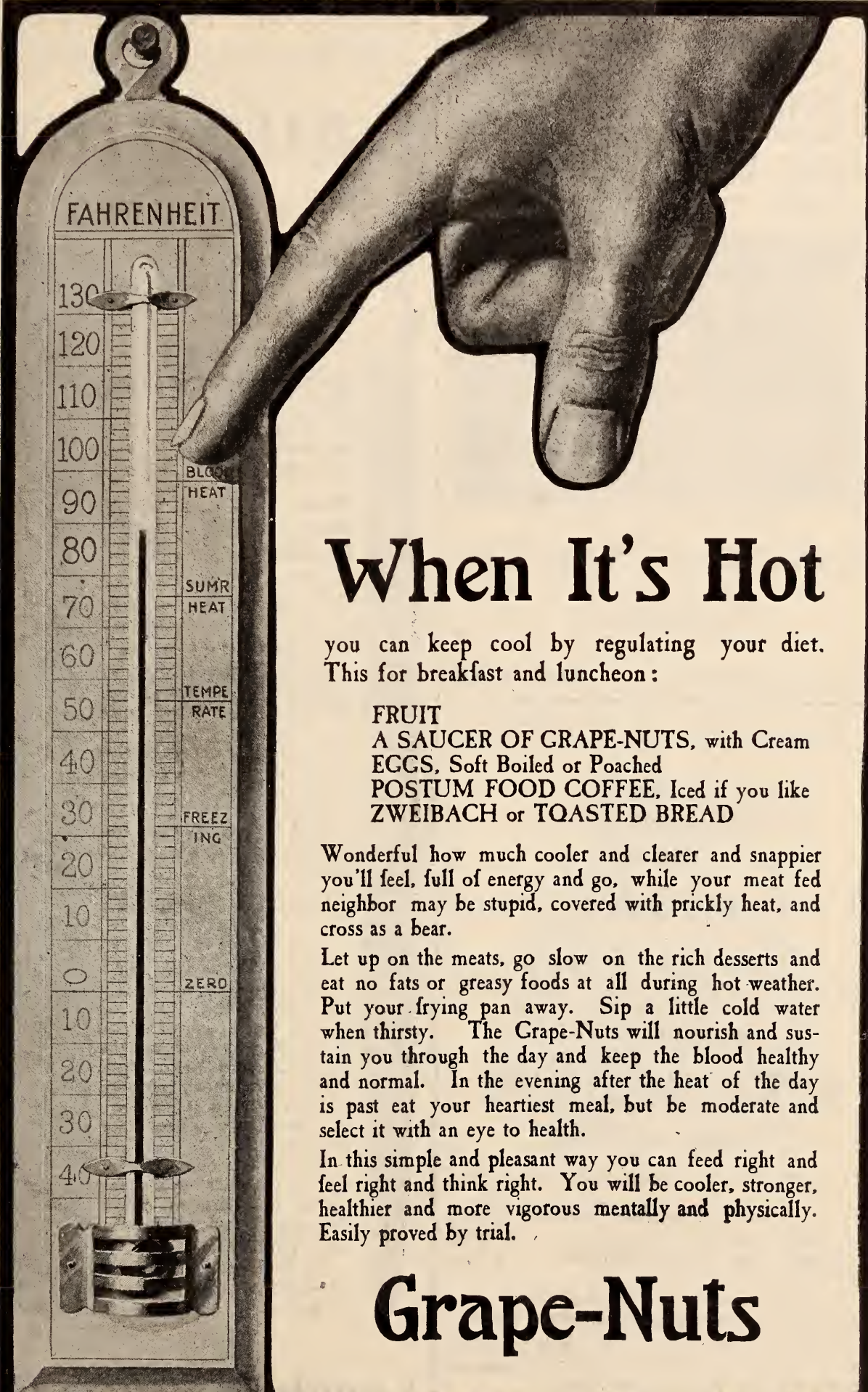

# When It's Hot

you can keep cool by regulating your diet.  
This for breakfast and luncheon:

**FRUIT**  
A SAUCER OF GRAPE-NUTS, with Cream  
EGGS, Soft Boiled or Poached  
POSTUM FOOD COFFEE, Iced if you like  
ZWEIBACH or TOASTED BREAD

Wonderful how much cooler and clearer and snappier you'll feel, full of energy and go, while your meat fed neighbor may be stupid, covered with prickly heat, and cross as a bear.

Let up on the meats, go slow on the rich desserts and eat no fats or greasy foods at all during hot weather. Put your frying pan away. Sip a little cold water when thirsty. The Grape-Nuts will nourish and sustain you through the day and keep the blood healthy and normal. In the evening after the heat of the day is past eat your heartiest meal, but be moderate and select it with an eye to health.

In this simple and pleasant way you can feed right and feel right and think right. You will be cooler, stronger, healthier and more vigorous mentally and physically. Easily proved by trial.

# Grape-Nuts

**THE  
DENSMORE  
DOES MORE**

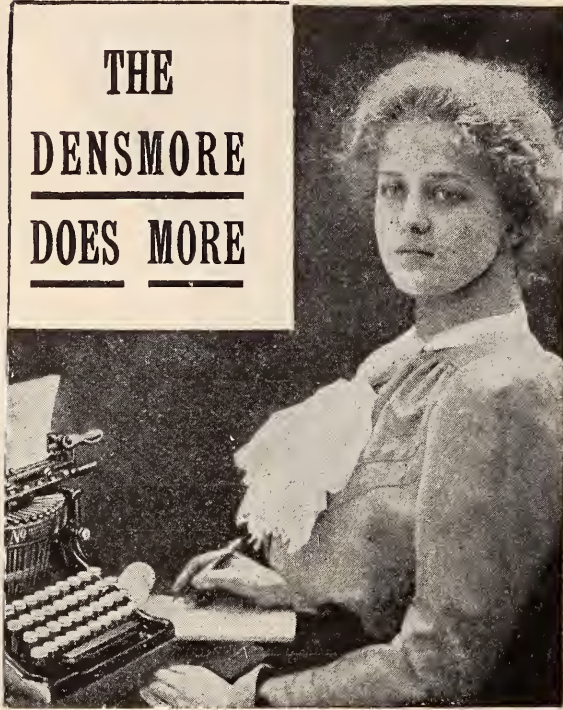

**Densmore Typewriter  
Company**

**309 Broadway New York**

**WANT A REEL?**

You can get one for nothing.  
Or at least for a few hours' work.

Send me

**15 Yearly Subscriptions  
to  
RECREATION**

and I will send you

**A TALBOT REEL**

Listed at \$20.00

Made by W. H. Talbot, Nevada, Mo.

This is one of the finest pieces of fishing tackle ever made. It is built like a gold watch. Equal to any Kentucky reel you ever saw.

**In Tournaments, Always a Victor  
Among the Angler's Treasures, Always the Chief**

I have but a few of these reels in stock and this offer will be withdrawn as soon as the present supply is exhausted.

Sample copies of RECREATION for use in canvassing furnished on application.

**Sent on Approval  
TO RESPONSIBLE PEOPLE  
Laughlin  
Fountain Pen**

**Guaranteed Finest  
Grade 14k.  
SOLID GOLD PEN.**

To test the merits of  
**RECREATION**

as an advertising medium  
we make this grand special offer, your choice of

These Two Popular Styles For Only **\$1.00** Postpaid to any Address

(By Registered mail 8 cents extra)

Holder is made of finest quality hard rubber, in four simple parts, fitted with very highest grade, large size 14k, gold pen, any flexibility desired—in feeding device perfect.

Either Style—**RICHLY GOLD MOUNTED** for presentation purposes, \$1.00 extra.

**Grand Special Offer**

You may try the pen a week; if you do not find it as represented, fully as fine a value as you can secure for three times the price in any other makes, if not satisfactory in every respect, return it and we will promptly refund your money.

Illustration on left is full size of Ladies' style; on right, Gentlemen's style. **Lay this RECREATION Down and Write NOW.**

Safety Pocket Pen Holder sent free of charge with each Pen.

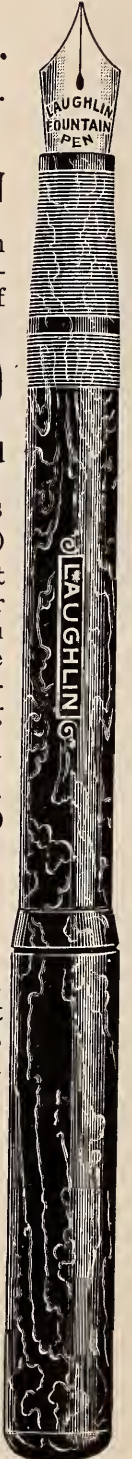

ADDRESS :

**Laughlin Mfg. Co.**  
424 Griswold St., DETROIT, MICH.



## HAY FEVER SUFFERERS

"Stay at Home—  
Go anywhere"

BUT TAKE

# ORANGEINE

## Powders

During the past five years, thousands of former sufferers have through Orangeine found

### Immunity and Relief

which they could not find at any Hay Fever resort.

#### TRIAL POWDERS FREE.

Orangeine Powders are sold by all progressive druggists, 25c. (6 powders); 50c. (15 powders); \$1 (35 powders). Write us for sample, full information, composition, and far-reaching human results. Address "ORANGEINE, CHICAGO"

# Orangeine

## FOR HUMANITY

Corrects "Bad Feeling"—Prevents Sickness--Offsets "Wear and Tear."

*Quickly dispels (even chronic cases of)*

Hay Fever, Colds, Dyspepsia,  
Headache, Asthma, Indigestion  
Stomach Upsets, Blues, Neuralgia,  
and a host of common ills

## EVERY MAIL IS LIKE THIS

Rev. F. W. Hamilton, Roxbury Station, Boston, Mass., writes: "Orangeine has become a household necessity. I am never without it. Thanks to its moderate, regular use, I have just passed through a prolonged period of labor and nervous strain, not only without undue fatigue, but feeling better after than before the experience."

Mr. J. J. Cone, Canon City, Colo., writes: "After ten weeks of facial neuralgia, I took two Orangeine powders per diem, in  $\frac{1}{2}$  cup of hot water. I am cured. Chronic asthma, which I have had for years, has been relieved, and at 68 I am in better health than for years."

Mrs. L. C. Bragdon, Lockport, N. Y., writes: "Orangeine is a God-send to poor working women. When over tired, I take an Orangeine powder, and feel revived in ten minutes."

### "NO MORE HEADACHE."

Mrs. R. Odell, New City, N. Y., writes: "I enclose \$1.00 for Orangeine. I would not be without it for worlds. When I was a little girl, I was overcome by heat (sun-stroke) and have suffered with headache, and never found anything to help me, until I found Orangeine. I can truthfully say, I have never felt so well in my life as since taking it. NO MORE HEADACHE."

**Proven:** *The intelligent, timely use of Orangeine secures good health and immunity from common and seasonable ailments.*

## REAL BABY TALK.

I am a baby, 11 months old, and nearly worn out already. Please let me alone.

I am not a prodigy, except to the extent that, not having anything to say, I don't talk. Two big persons claim to be my parents. Why can't they let it go at that? I have never denied the charge. I haven't much data to go by, but I don't think I am either a magician, a learned pig or a *virtuoso*. I don't hanker for applause; so it will be an appreciated favor if you won't put me through any parlor tricks.

If I have my wealthy old Uncle Ezra's nose, congratulate Uncle Ezra; but don't blame me. I may be a kleptomaniac for all I know, but I can't help it.

Don't rattle rattles at me; they rattle me. Don't goo-goo and ootsie-kootsie at me. I can't understand it any better than I can the English language.

The pain I have is not in my stomach, but in my neck. I don't want to be entertained or mystified or medicated or applauded; and if you don't want me to grow up to be a hypochondriac, a stamp collector, an awful example, a ping pong enthusiast, or a misanthrope, you just lemme be!—Smart Set.

IF YOU WOULD LIVE NEXT TO  
NATURE, READ RECREATION.



## Her Marvelous Growth of Hair.

**FREE TO ALL,** a trial package of a new and wonderful remedy mailed free to convince people it actually grows hair, stops hair falling out, removes dandruff, and quickly restores luxuriant growth to shining scalps, eyebrows and eyelashes. Send your name and address to the Altheim Medical Dispensary 8163 Foso Building, Cincinnati, Ohio, for a free trial package, enclosing a 2-cent stamp to cover postage. Write to-day.

# PIANO Do You Want a Genuine Bargain

Hundreds of Upright Pianos returned from renting to be disposed of at once. They include Steinways, Knabes, Fischers, Sterlings and other well known makes. Many cannot be distinguished from new yet all are offered at a great discount. Uprights as low as \$100. Also beautiful New Uprights at \$125, \$135, \$150 and \$165. A fine instrument at \$290, fully equal to many \$400 pianos. Monthly payments accepted. Freight only about \$5. Write for list and particulars. You make a great saving. Pianos warranted as represented. Illustrated Piano Book Free.

## FROM LYON & HEALY

39 Adams St., CHICAGO.

World's largest music house; sells Everything known in Music

ON YOUR OUTING THIS SUMMER

YOU WILL NEED A

### Duplex Fork



for handling hot potatoes, ears of corn, boiled eggs, and other hot food, and you will find it indispensable for use with pickles, fish and meats that an ordinary fork will break. The forks are always open and ready for use, and with a slight pressure on the handle anything can be easily taken hold of without fear of breaking.

Postpaid, 25 Cents

E. A. LYFORD, 3090 Gilbert Ave., Cincinnati, O.  
Mention RECREATION.

# PAROID ROOFING

"IT LASTS"

Prevents leaky roofs and makes a satisfied owner. Contains no tar. Easy to apply with kit in each roll.

Write for sample.

Mention RECREATION

F. W. BIRD & SON

MAKERS

East Walpole, Mass., U.S.A.

New York Chicago

Those who mix their own developer should put no bromide in the stock solution during cold weather. Snow pictures made with bromide in the developer often are chalky, lacking any semblance of half tone in the snow; if snapshots, they are almost sure to have this defect. Restraining can be effected easily by the proportions used of each component of the developer, or, if it comes to the worst, a tray of weak bromide solution can be used to dip a plate in if it is running away from over exposure, rinsing the plate of bromide before returning to the developer.

For fixing, the use of 2 successive hypo baths can be confidently recommended. The first clears the coloring matter of the developer from the negative and becomes rapidly discolored. It should, therefore, be frequently renewed. The second bath need not be so frequently changed. For ordinary amateur work a dish holding one negative may be used for bath No. 1, and one holding 2 or 4 for bath No. 2.

A good pasting tool is made by enclosing a tuft of cotton wool inside a piece of wash leather, the edges of which are gathered together and tied with a string to form a handle. The contrivance will spread thick starch paste evenly and smoothly. For large work it will be found particularly useful, as thick paste is more adhesive than thin, and the print on which it is spread is easier to handle.

A glossy blue printing paper may be made by sensitizing carbon single transfer paper in the following solution mixed in equal quantities:

- Potassium ferricyanide ..... 1 ounce
- Water ..... 4 ounces
- Iron ammonia citrate..... 1 ounce
- Water ..... 4 ounces

To remove the film from a cracked negative, immerse the negative in:

- Hydrofluoric acid ..... 2 drams
- Glycerine ..... 1 dram
- Alcohol ..... 25 drams
- Water ..... 25 drams

As soon as the film begins to lift at the corners help it off with a camel hair brush, and transfer to a fresh piece of glass coated with gelatine. Then dry.

The slipping of tripod legs may be entirely prevented by replacing the spikes with india-rubber shod walking stick ferules, which can be obtained at most umbrella shops.

Do not dip the fingers in the solution until diluted with water after film floats off. The operation must be performed with care and a clear conscience.—Photo-American.

A developing dish may be improvised by flooding the bottom of a plate box, the size required, with melted beeswax.

A highly glazed surface is obtained by drying finished prints on a ferrotype plate, as with ordinary p.o.p.

# Free! Hunters, Sportsmen, Free!

## Campers Out, Etc. Etc.

Fairly bristles with facts and information from start to finish. A complete up-to-date volume, entirely covering the subject of "Camping Out and Outfits."

A Book of 136 Pages

Pronounced by the very best authorities the most practical work ever published on the subject.—A Handsome volume.

Glitters with Pictures  
from Cover to Cover

136 PAGES. In all  
over 200 Illustrations

Bound in Linen, 5 Col-  
or Covers

Size, 6½ x 4½ inches

**FREE!**

Brimfull of brainy facts exhaustively covering every subject from A to Z, interesting and of instructive value and service to every sportsman and camper out, old or young. We have thousands of letters from all over the World (some from noted sportsmen),

who congratulated us upon these books. Contains a thousand facts of value never before put in print, and there is scarcely a campaigner *anywhere*, no matter how old or experienced he may be, who cannot learn something from these books. They are better than some books sold at \$1.00 a copy, or your money refunded.

1st edition of 50,000 copies nearly exhausted.

**They are Free to You** on receipt of 10c., coin or stamps to cover cost of mailing them to you. Address

If you be wise write at  
once for this book;  
It'll surprise you

**"Buzzacott" Dept. A**  
**COMPLETE CAMP OUTFITTER**

Racine Junction, Wis. or Chicago, Ill., U. S. A.

Mention RECREATION.

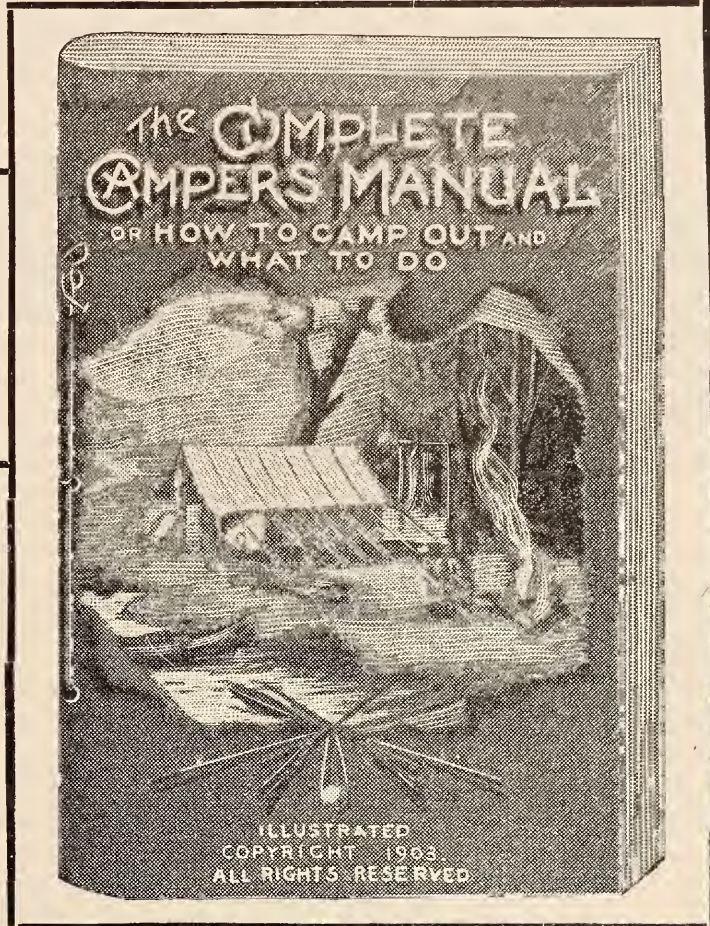

# HAY FEVER VANQUISHED

## THE WILSON HAY FEVER DISKS

placed in the nasal passages give absolute protection against dust and pollen without impairing respiration. Invisible and perfectly comfortable.

After wearing it a few minutes the hay feverite experiences the wonderful relief felt on an ocean voyage or in an "exempt" region. Price \$1.50 per pair prepaid.

Money refunded if not satisfactory.

### SEND FOR BOOKLET

with statements of leading medical journals, physicians, officers of hay fever associations, and hosts of relieved sufferers. **WILSON HAY FEVER DISK CO.**

41 STATE ST., ROOM 61

CHICAGO, ILL.



TRADE MARK

**BORATED  
TALCUM**

# TOILET POWDER

A Positive Relief  
For  
**PRICKLY HEAT,  
CHAFING, and  
SUNBURN,** AND ALL AFFLICTIONS  
OF THE SKIN.

"A little higher in price, perhaps, than worthless substitutes, but a reason for it." Removes all odor of perspiration. Delightful after Shaving. Sold everywhere, or mailed on receipt of 25c. Get Mennen's (the original). Sample Free.

GERHARD MENNEN CO., Newark, N. J.

### EXTRAORDINARY OFFER.

To any person sending me \$1 for a year's subscription to RECREATION, I will give free one of the following books: 6th and 7th Books of Moses. This is a great book. Every home should have one. Volumes I-II., bound together in one volume; regular price is \$1. "The Almighty Dollar" is a new book just published, and is worth its weight in gold to any one. Can not be obtained for less than \$1 anywhere.

"Hunter's Guide and Trapper's Companion." This is a book every hunter and trapper should have. Descriptions of these books will be sent for a stamp. This is the greatest offer ever made, and you should not let this pass. Old subscribers may avail of this offer by sending 10 cents extra. Address Henry Nelson, Eckwoll, Minn.

## ARNICA Tooth Soap

*the International Dentifrice*

Beautifies the teeth, hardens the gums, sweetens the breath. Preserves as well as beautifies the teeth. Comes in neat, handy metal boxes. No powder to scatter, no liquid to spill or to stain garments.

**25 Cents**  
At all Druggists.

**C. H. STRONG & CO., Proprietors,**  
Chicago, U. S. A.

### THEY REFUSE TO IMPROVE.

Whenever I return to civilization, after an absence of some duration in the wilderness, the first break I make is for the book store to get RECREATION, and where I'm known, they generally have it laid aside for me. No publication has a greater attraction for me or pleases me more. I am a rifle and revolver crank and firmly believe in following the ethics of true sportsmanship in whatever branch of sport I engage in.

Here we frequently see large numbers of men, women and boys on the streets, loaded down with ducks, which they sell at 5 cents each, or less than 2 cents American money. Surely the wild hog, indigenous to this country, is entitled to more consideration at the hands of sportsmen than his human brother is.

And now a word about the Marlin Co. They make a good rifle in some respects, but its extractor is decidedly faulty and unreliable, after a little use, and no one who hunts big game can afford to take chances on a rifle's clogging at a critical moment. I recently had an experience of that kind, on the Isthmus of Tehuantepec, when I was charged by some wild cattle, and while I escaped with no greater damage than some torn clothing and a bruised hip, I had such a close call it makes me shiver to think of it.

Why the Marlin people don't remedy this defect in their guns I can not comprehend, for certainly they have had their attention called to it often enough.

I have a friend in Kansas City who is one of the best and most skilful amateur mechanics I have ever known. He is a gun crank and so situated that he can devote all the time he wishes to indulging his hobby. His den is filled with ingenious appliances for sporting purposes, all of his own handiwork.

While visiting him several months ago, he took down his Marlin rifle and, taking out the breech bolt, showed me a new extractor, simple and strong, made of one piece, which he had fitted into the slotted groove which formerly held the combination affair made at the factory. His extractor worked as smoothly and easily as could be expected of one strong enough to grip the head without slipping off when a shell happens to swell in the chamber. The Marlins know this man personally, and they take special pains in executing any order he may place with them for anything in the gun line; so he sent them the breech bolt, with his extractor fitted in for inspection, and generously offered them his idea, free, if they wished to embody the improvement in the construction of their rifles. But, no; they returned it and declined to make use of it.

What in the name of heaven is the cause of such perverseness? To me it is inexplicable.

Tehamoc, Mexico City, Mex.



# A Prescription for all PAIN

A prescription that for 60 years has been alleviating the sufferings of mankind as nothing else can. That has withstood *all* tests; conquered *all* imitators; overcome *all* substitutes. POND'S EXTRACT is a prescription THAT CURES—stops *all* pain and starts the healing instantly. It does it with an efficacy no other remedy in the world possesses. There is nothing like it. It CURES because it contains the pure extract of the most valuable anodyne (pain relief) known in materia medica.

## ***If You Want a Cure That's Safe and Sure***

you want POND'S EXTRACT—it CURES. Don't expect a substitute to cure. Water WON'T cure. That's why ordinary witch hazel is so cheap—*it's nearly all water*—that's why it WON'T cure.

For burns, scalds, wounds, inflammation, rheumatism, neuralgia; for cuts, bruises, lameness, soreness, strains, sprains, sunburn, chafing, insect bites and stings, irritation after shaving, get POND'S EXTRACT. It is the *pure* extract of *Hamamelis Virginica*, combined with other pain relieving ingredients—that's why

## **IT CURES**

Sold only in sealed bottles,  
enclosed in buff wrappers.



## STIMULATION

WITHOUT

## IRRITATION

# Will Make Hair Grow

## Evans Vacuum Cap

This appliance will massage the scalp and force a free and healthful circulation. It will stop hair from falling out and restore a normal growth where live follicles exist. It is used about ten minutes twice a day. Price of outfit, complete, is \$35.00. Money refunded in full if not satisfactory after 30 days' use.

A traveling man writes under date of June 6th from the Essex Hotel, Boston:

*Gentlemen:—I purchased one of your Caps a few months ago and as I am certainly well pleased with the results I am getting I wish to recommend your method of treatment.*

*My hair has been falling out over fifteen years, during which time I had tried practically every supposed remedy with absolutely no results, (except injurious), but thanks to the "stimulation without irritation" method the fuzz on my head is developing into hair.*

A fac-simile of above letter bearing name and address, together with other convincing letters, will be sent on application to any one interested.

**EVANS VACUUM CAP CO.**

ST. LOUIS OFFICE  
Fullerton Bldg.

N. Y. OFFICE  
Room 12, 1300 Brdwy



Comfort and Convenience for either  
a short or long stay in Boston  
Beautifully located near Back Bay  
Station

RATES ON APPLICATION

HOW OLD SPORT STOPPED THE GAME HOG'S LITTLE GAME.



Ah! A good day and a fine bag. Now I must get this stuff home somehow.

# DIAMONDS ON CREDIT

**I**F YOU are interested in Diamonds, you will want a copy of our **NEW SUMMER CATALOGUE**, for it shows the latest creations in artistic Diamond mountings, fine jewelry and watches. These new and fine goods you will not find illustrated in the catalogues of other houses until next fall, for we are the only house in the Diamond and jewelry business which issues a complete catalogue between seasons. Everything illustrated is quoted at exceptionally low prices and sold on the **POPULAR LOFTIS SYSTEM** of easy payments. Select any article that you like and it will be delivered at your door with all express charges paid. Only one-fifth of the price need be paid at first; the balance being arranged in a series of small monthly payments extending over eight months. No security is required; no interest is charged and no publicity is created when you buy on our **CONFIDENTIAL CHARGE ACCOUNT SYSTEM**. If you make a selection it will be upon the distinct understanding that your money will be promptly returned in case you decide not to purchase. We are the largest concern in the business and sell only the finest genuine goods, and at prices ranging from ten to twenty per cent below those of other houses. Every Diamond is sold under a written guarantee of quality and value and may be exchanged at any time in the future for other goods or a larger stone at the full original price. Our **Confidential Credit System** is open to all honest persons without regard to their financial worth; but if you prefer to buy for **spot cash** we make the most startling and liberal offer ever made. It is no less than guaranteeing the return of all money paid at any time within one year—less ten per cent, the reasonable cost of doing business. We are one of the oldest houses in the trade (Est. 1858). We refer to any bank in America—for instance, ask your local banker to consult his Dun or Bradstreet book of commercial ratings and he will tell you that we stand at the top in credit, reliability and promptness. We have a number of attractive booklets that we will be glad to send you if you write promptly for our **New Summer Catalogue**.

**LOFTIS BROS. & CO.**

Diamond Importers and Manufacturing Jewelers

Dept. H-82, 92 to 98 State St.

Opposite Marshall Field & Company

**Chicago, Ill.**



This old trunk's the very thing, and a few coats on top will put the warden off the scent.



H. J. TILLOTSON, M. D.  
The Master Specialist of Chicago, who Cures Varicocele,  
Hydrocele, and treats patients personally.

Established 1880.  
(COPYRIGHTED)

# Varicocele Hydrocele

**Cured to Stay Cured in 5 Days.  
No Cutting or Pain. Guaranteed  
Cure or Money Refunded.**

**VARICOCELE.** Under my treatment this insidious disease rapidly disappears. Pain ceases almost instantly. The stagnant blood is driven from the dilated veins and all soreness and swelling subsides. Every indication of Varicocele vanishes and in its stead comes the pleasure of perfect health. Many ailments are reflex, originating from other diseases. For instance, innumerable blood and nervous diseases result from poisonous taints in the system. Varicocele and Hydrocele, if neglected will undermine physical strength, depress the mental faculties, derange the nervous system, and ultimately produce complicated results. In treating diseases of men I always cure the effect as well as the cause. I desire that every person afflicted with these or allied diseases write me so I can explain my method of cure, which is safe and permanent.

My consultation will cost you nothing, and my charges for a perfect cure will be reasonable and not more than you will be willing to pay for the benefits conferred.

**Certainty of Cure** is what you want. I give a legal guaranty to cure or refund your money. What I have done for others I can do for you. I can cure you at home.

**Correspondence Confidential.** One personal visit at my office is preferred, but if it is impossible for you to call, write me your condition fully, and you will receive in plain envelope a scientific and honest opinion of your case, Free of charge. **My home treatment is successful.** My books and lectures mailed free upon application.

H. J. TILLOTSON, M. D., 140 Tillotson Bldg, 84 Dearborn St., CHICAGO



How easy! Won't the boys laugh when I tell them.

**TRISCUIT**  
 A WHOLE WHEAT PRODUCT  
 THE ELECTRIC BAKED BISCUIT

117

TRISCUIT is unexcelled as a food for children, because it contains all the elements of Whole Wheat, which go to properly nourish the whole body. Wheat contains the properties to make bone, teeth, muscle, in fact every part of the body.

**TRISCUIT**  
 IS  
**NATURE'S FOOD**  
 BY  
**NATURE'S PROCESS**

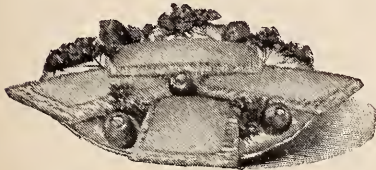

WITH CHEESE OR FRUIT PRESERVE

TRISCUIT, the highest achievement known to the science of food production, is made possible by that other great achievement, the application of electricity; for Triscuit is made and baked by electricity.

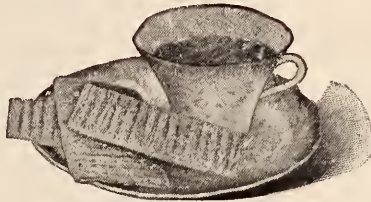

WITH COCOA OR OTHER DRINK

Composed of the whole wheat berry, God's perfect gift to man. Not touched by human hands during the process of manufacture. Cleaned, filamented, formed and baked by electricity.

Placing Triscuit in warming oven a few moments will renew crispness.

SEND FOR DESCRIPTIVE BOOKLET (FREE.)

**The Natural Food Company,**  
**Niagara Falls, N. Y.**

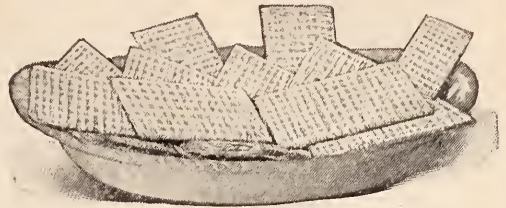

AS A BREAD OR TOAST

TRISCUIT is a neat compact form of filamented wheat, its shape and size making it convenient to be carried wherever you may go, and to be used at any time. Triscuit is an all-day food for everybody, and contains the properties for sound teeth, perfect digestion, and an entirely healthy body in accord with Nature's laws.

Triscuit can be used as a Bread, Toast, Wafer or Cracker. Delicious with Cheese, Fruit, Preserves, etc.



What struck Old Sport? There must be something in that trunk beside clothes.

## SOME RARE OPPORTUNITIES

These goods are all new, and will be shipped direct from factory. Prices named are those at which manufacturers and dealers usually sell. Here is a good chance to get

A Book, a Gun, a Camera  
A Sleeping Bag, a Fishing Rod  
A Reel, a Tent, } FREE OF COST

Subscriptions need not all be sent at once. They may be sent in installments as taken and credit will be given on account. When the required number is obtained the premium earned will be shipped.

**These Offers are subject to change without notice.**

### TO ANY PERSON SENDING ME

TWO yearly subscriptions to RECREATION at \$1 each, I will send a copy of *Hunting in the Great West*, cloth; or a Zar Camera, listed at \$1; or an Ingersoll Watch or Cyclometer, listed at \$1; or a Recreation Waterproof Match Box, made by W. L. Marble and listed at \$1; or a Shakespeare Revolution Bait listed at 75 cents; or a Laughlin Fountain Pen; or a dozen Trout Flies, assorted, listed at \$1; or a pair of Attachable Eyeglass Temples, gold-plated, made by Gall & Lembke; or one Rifle Wick Plug, made by Hemm & Woodward, Sidney, Ohio, 30 caliber to 50 caliber, or Shotgun Wick Plug, 20 gauge up to 10 gauge.

THREE subscriptions at \$1 each, a safety pocket ax, made by W. L. Marble and listed at \$2.50; or a dozen Bass Flies, assorted, listed at \$2; or a pair of chrome tanned horsehide hunting and driving gloves, listed at \$1.50, made by J. F. Luther Glove Co.; or a pair of Shotgun Wick Plugs made by Hemm & Woodward, Sidney, Ohio, 20 gauge to 10 gauge.

FOUR subscriptions at \$1 each, an Ideal Hunting Knife, made by W. L. Marble and listed at \$2.50; or a .32 caliber Automatic Forehand Revolver, made by the Hopkins & Allen Arms Co.; or a No. 822 Rifle made by the Hopkins & Allen Arms Co., listed at \$4.50.

FIVE subscriptions at \$1 each, a copy of *Cruisings in the Cascades*, cloth; or a set of Nehring's Convertible Ampliscopes, listed at \$5.00; or an Ideal Hunting Knife made by W. L. Marble, and listed at \$3; or a polished Buffalo Horn Gun Rack, made by E. W. Stiles; or a Forehand Gun, made by the Hopkins & Allen Arms Co., listed at \$6; or a pair of lock lever skates, made by Barney & Berry, listed at \$4.50; or a pair of gauntlets, for hunting and driving, ladies' size, listed at \$2.50, made by J. P. Luther Glove Co., or a J C Hand trap made by the Mitchell Mfg. Co., listed at \$4.

SIX subscriptions at \$1 each, a Hawkeye Refrigerating Basket made by the Burlington Basket Co., or one dozen Eureka golf balls listed at \$4; or a Forehand Gun made by the Hopkins & Allen Arms Co., listed at \$9.; or a Pocket Poco B  $3\frac{1}{4} \times 4\frac{1}{4}$ , made by the Rochester Optical & Camera Co. listed at \$9.

SEVEN subscriptions at \$1 each, a copy of *The Big Game of North America*, or of *The American Book of the Dog*, cloth, or one set Lakewood golf clubs, 5 in number, listing at \$5; or a series IIB or IID Korona Camera, made by the Gundlach Optical Co., listed at \$10.

EIGHT subscriptions at \$1 each, a 4 x 5 Weno Hawk-Eye Camera, made by the

Blair Camera Co., and listed at \$8.; or a series I, 4x5, Korona Camera, made by the Gundlach Optical Co., listed at \$12.; or a pair of horsehide Hunting shoes, made by T. H. Guthrie, Newark, N. J., and listed at \$8.

NINE subscriptions at \$1 each, an Acme single shot gun, made by the Davenport Arms Co., and listed at \$8.

TEN subscriptions at \$1 each, a Cut-Glass Salad Bowl, made by Higgins & Seiter, and listed at \$4.50; or a Yawman & Erbe Automatic Reel, listed at \$6 to \$9; or a Bristol Steel Fishing Rod, listed at \$6, or less; or a Waterproof Wall Tent 7 x 7, made by Abercrombie & Fitch, and listed at \$8.; or a pair of horsehide Hunting Boots, made by T. H. Guthrie, Newark, N. J., and listed at \$10; or a Rough Rider rifle telescope, made by The Malcolm Rifle Sight Mfg. Co., and listed at \$12.

TWELVE subscriptions at \$1 each, a Peabody Carbine valued at \$12; or a Davenport Ejector Gun, listed at \$10., or a Cycle Poco No. 3, 4x5, made by the Rochester Optical and Camera Co., listed at \$15; or an 8 ft. folding canvas boat, made by the Life Saving Canvas Boat Co., listed at \$29.

FIFTEEN subscriptions at \$1 each, a Shakespeare Reel, Silver Plated, listed at \$15; or a set of rabbit plates made by Higgins & Seiter, and listed at \$8, or a Field Glass made by Gall & Lembke; or a Kenwood Sleeping Bag, complete, with canvas cover, listed at \$16; or a Bulls-Eye rifle telescope, made by The Malcolm Rifle Sight Mfg. Co., and listed at \$16; or a Pneumatic Camp Mattress, with pillow listed at \$18; or a 10 ft. special canvas boat, made by the Life Saving Canvas Boat Co., and listed at \$35.

TWENTY subscriptions at \$1 each, a 14-karat Gold Hunting-case Watch, with Waltham Movement, listed at \$20; or an Elita single shot gun, made by the Davenport Arms Co., and listed at \$18., or an Acme Folding Canvas Boat, No. 1, Grade, A listed at \$27; or a Mullins Duck Boat, listed at \$20; or a Shattuck double hammerless shot gun listed at \$25.

TWENTY-FIVE subscriptions at \$1 each, an 11-foot King Folding Canvas Boat, listed at \$38; or a 4 x 5 Planatic lens, made by the Rochester Lens Co., and listed at \$25; or a Syracuse Grade OO, double hammerless Gun, made by the Syracuse Arms Co., and listed at \$30.

THIRTY subscriptions at \$1 each, a Waterproof Tent, 14½ x 17, made by Abercrombie & Fitch, and listed at \$25; or an Ithaca, quality No. 1, plain, double barrel, hammerless breech loading shot gun, listed at \$40.; or a Field Glass, made by C. P. Goerz.

THIRTY-FIVE subscriptions at \$1 each, a 14-foot King Folding Canvas boat, listed at \$48.

FORTY subscriptions at \$1 each, a Savage .303 Repeating Rifle; or a No. 10 Gun Cabinet, made by the West End Furniture Co., and listed at \$32.

FORTY-FIVE subscriptions at \$1 each, a Royal Anastigmat Lens, 4x5, series I, made by Rochester Lens Co., and listed at \$45.

FIFTY subscriptions at \$1 each, a No. 20 Gun Cabinet, made by the West End Furniture Co., and listed at \$38.

TWO HUNDRED subscriptions at \$1 each, a strictly first class upright piano, listed at \$750.

Address, **Recreation** 23 West 24th St.  
New York



## IN CAMP

Experience teaches that the success of a vacation in the woods depends fully as much upon a careful choice of food and drink as upon congenial companions.

# Dewar's Scotch Whisky

“Special” and “White Label”

has helped to kindle good fellowship round many a well-remembered camp-fire. Be sure to include it in your supplies this year.

### THIS CAMPING PICTURE

“IN CAMP” (copyright, 1903, by Frederick Glassup) is an original drawing by Ray Brown. It is printed in four colors on heavy plate paper, 9 x 12, without advertisement of any kind. Sent to any address on receipt of 10 cents in silver. Suitable for framing in club-house or home. Next month, a yachting picture by the famous marine artist, Carlton T. Chapman.

FREDERICK GLASSUP

*Sole Agent for John Dewar & Sons, Ltd.*

126 Bleecker Street, New York



We couldn't think of letting such a great hunter leave us this way. We'll go and talk it over with the judge.

## ENTRANCING. The EDISON PHONOGRAPH



Don't judge the **Phonograph** by what you have heard—the imitations or the old styles—but call at the nearest dealer's and hear the **Phonograph** with Mr. Edison's recent improvements.

5000 DEALERS SELL PHONOGRAPHS  
**NATIONAL PHONOGRAPH CO., Orange, N. J.**  
 NEW YORK CHICAGO SAN FRANCISCO EUROPE: ANTWERP, BELGIUM  
 88 Chambers St. 304 Wabash Ave. 933 Market St. 32 Rempart Saint Georges

**Free:** If you send your subscription to RECREATION through me or direct to the office to be placed to my credit, I will send you free of charge, any one of the articles mentioned below:

Shot gun bench crimper, sells for 75 cents, in 10-12-16-20 gauge.

Shot gun cleaning rod, three attachments, sells for 50 cents, in 10-12-16 gauge.

Micrometer powder and shot measure, adjustable, and for both black and smokeless powder, sells for 65 cents.

U. S. Government rifle cleaner, any caliber, with attachments, sells for 60 cents, packed in neat canvas bag.

A duck, snipe or turkey call, sells for 75 cents each, best made.

A hand painted sporting picture, suitable for framing and just the thing for your den, worth \$1.50.

"Hunting in the Great West," by G. O. Shields. H. S. Hill, 815-11th Street. N. E., Washington, D. C.

## Here is Another!

If you will send me

30 Yearly Subscriptions

to

RECREATION

I will send you

A No. 10 Goerz Trieder-  
Binocular Field Glass

Listed at \$38.00

Every well-informed man knows the great power of this modern prismatic field glass. It is indispensable to every hunter, and is one of the latest and best on the market.

I have but a few of these instruments on hand and the offer will be withdrawn as soon as the supply is exhausted. Therefore, if you want one

**START IMMEDIATELY.**

Sample copies of RECREATION for use in canvassing furnished on application.

## PATENTS

promptly obtained **OR NO FEE.** Trade-Marks, Caveats, Copyrights and Labels registered. **TWENTY YEARS' PRACTICE.** Highest references. Send model, sketch or photo. for free report on patentability. All business confidential. **HAND-BOOK FREE.** Explains everything. Tells How to Obtain and Sell Patents, What Inventions Will Pay, How to Get a Partner, explains best mechanical movements, and contains 300 other subjects of importance to inventors. Address,

**H. B. WILLSON & CO.** Patent Attorneys  
786 F Street, N. W., WASHINGTON, D. C.

My splendid premium, the hammerless Ithaca, is not only a beautiful gun, but a close, hard shooter. I thank you for your generosity and fair dealing.

A. J. Johnston, Wilkinsburg, Pa.



Size 17 in.

A skilled mechanic has invented lately a **Musical Clock** which, besides keeping perfect time, running 8 days with one winding, striking the hours and halves, will also **play favorite airs every half hour.** As the cost is very low, many prefer buying the clock with the musical attachment. Ask your jeweler for it or send to **E. L. CUENDET, Mfr., 7 Barclay Street, New York**



# Save Half Your Cigar Money

# and Get a Better Smoke

We are making a great success of selling direct from factory to smoker exclusively, at **half retail prices**, the best possible cigars—all time tested, tried-out brands; not one blend but many, to suit every possible taste. We have made a reputation for quality during the years we sold to dealers. Now we are making a reputation for saving in price as well, when we sell **direct from factory to you**. The saving in price does not come from out of the cigars—they are better than ever. It comes from saving you the jobbers', the wholesalers' and the retailers' profits—three profits in **your** pocket. The saving in price is clear to all. You can prove without risk, how we'll please you in quality and critically satisfy your taste, for if you don't get as good a cigar or a better one from us for less money than you pay now—if you are not altogether pleased, you get **your money back**.



Why throw away one half your cigar money on any "in between man" in the face of a "no risk" guarantee like this?

We will at first send you assortments from which to make selections. For **60 cts.**, an assortment of 12 cigars showing ten cent and two for a quarter values; for **35 cts.**, 12 high grade fives; for **\$1.00**, a trial box of 25 cigars, showing fifteen 10c. values and ten straight 5c. cigars; for **\$1.25**, an assortment of 25 ten cent and three-for-a-quarter values, each separately wrapped and described, showing you how two-for-a-quarter and ten cent cigars can be bought in boxes of 25 and 50 for from 4 to 6 cts. each, others from 2 to 3 cts. each, **all transportation charges prepaid**, or let us send you our free illustrated booklet, "*Rolled Reveries*."

"Le Grande, Cal.—They are better than I could get here for twice the money."—Name supplied on request.

**JOHN B. ROGERS & CO., "The Pioncers."**

**93 Jarvis Street, BINGHAMTON, N. Y.**

I once had a Marlin shot gun, which, but for 2 faults, would have been a desirable weapon. It overshot, and the extractor was so weak that if the shell swelled at all it remained in the barrel for me to get out as best I could.

I still have a Marlin rifle that I bought several years ago to take on a deer hunt. When about ready to start, I discovered that the extractor was broken. I wrote the Marlin people for another, saying I would send money on receipt of bill, as I did not know the price. They replied that they did not care to open small accounts, but would send extractor when I sent the money. Having no time nor desire for further correspondence I hung their gun up and bought a Winchester. The Marlin still hangs, awaiting the coming of some one fool enough to buy it.

Peters' old Victor shell, primed with black power and loaded with King's, was exceedingly unsatisfactory. Sometimes the primer would not explode, and the penetration was always poor. Now that they are putting out a better class of goods, they make a mistake in not advertising again in RECREATION. It would double the sale of their goods. Subscriber, Topsham, Me.

## ILLUSTRATING is a Money-Making

profession. We teach you by mail to become an **Illustrator, Ad.-Writer, Journalist, Proofreader, Bookkeeper, Stenographer, Electrician, Electrical Engineer, etc.** Write for **Free** illustrated book, "**Struggles With the World**," and mention the subject which interests you. **Correspondence Institute of America, Box 701, SCRANTON, PA.**



## ATTENTION BASS FISHERMEN !!

**What It Is.** A Bass lure combining all the good points of the old fashioned spinner baits with the construction of the modern wooden minnow.

**What It Will Do.** This lure is constructed in a new manner with a new feature and will catch more bass than any other artificial lure.

**How To Get It.** Send one dollar to Recreation for a year's subscription to be credited to my account and I will mail you one postpaid. **W. B. HAYNES, 274 Park Street, Akron, Ohio.**

**FREE.** To anyone subscribing to RECREATION, through me I will give a cloth copy of one of Cooper's, Dickens', Dumas', Thackeray's or Conar Doyle's books. Address, **J. M. RUGEN, 2103 West Lake St., Chicago, Ill.**

No. 58

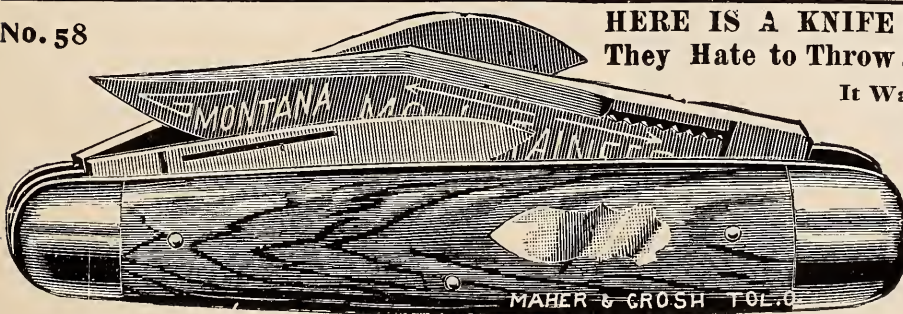

**HERE IS A KNIFE Men Love So Much They Hate to Throw an Old Handle Away**

**It Was Teddy's Camp Knife!**

No. 58. Cut is exact size; ebony handle, 3 blades, German Silver ends. The long blade is for rough or fine work; the medium blade is as thin as a razor. Price, postpaid, \$1.66 for \$5.

### Our JACK KNIFE

48c.

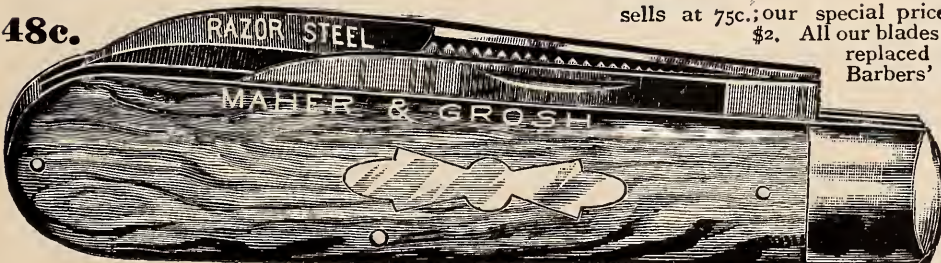

sells at 75c.; our special price is 48c. postpaid, 5 for \$2. All our blades file tested; warranted; replaced free if soft or flawy. Barbers' hollow ground **Razor and Strop** to suit, \$1.33. Send for free 80 page list and "How to Use a Razor."

**Maher & Grosh Co.**  
74 A Street  
Toledo Ohio

## Paint Your House With Carrara

And Have it Guaranteed to Look Better, Wear Longer, and Cost Less Than the Best White Lead Paints.

We Send Name of Nearest Carrara Dealer, 50 Sample Colors and Illustrated Book, "How to Paint a House," Free to All Who Send Name and Address.

There is but one "Carrara." It is made by the Carrara Paint Agency, 1007 Carrara Building, Cincinnati, O., and it is the only paint in the world that is absolutely guaranteed not to fade, crack, chalk, peel, blister or scale. It is not affected by acids or gases, and it covers more surface gallon for gallon than the best white lead and oil and costs less than the cheap mixed paints that injure more than they protect.



The Waldorf-Astoria, New York, One of the Most Magnificent Hotels in the World, Has Used Tons and Tons of the World-Famous Carrara Paint. New York, one of the finest in the world, has used tons of Carrara because it is the best that can be found in the market today.

For interior or exterior it has no equal. Smooth and clean, it has stood the rigid test of time and man. If you want to save half your paint bills send your name and address for nearest distributing depots, 50 sample colors and a beautiful illustrated book sent free, showing a large number of fine houses just as they have been painted with Carrara, and keep well in mind that Carrara is the only paint ever backed by a positive guarantee in every case.

## REVELL & CO.

CHICAGO



## FURNITURE OFFICE DESKS

THE LARGEST DISPLAY  
THE LOWEST PRICES

ALEXANDER H. REVELL & CO.  
Wabash Ave. and Adams St., CHICAGO, ILL.

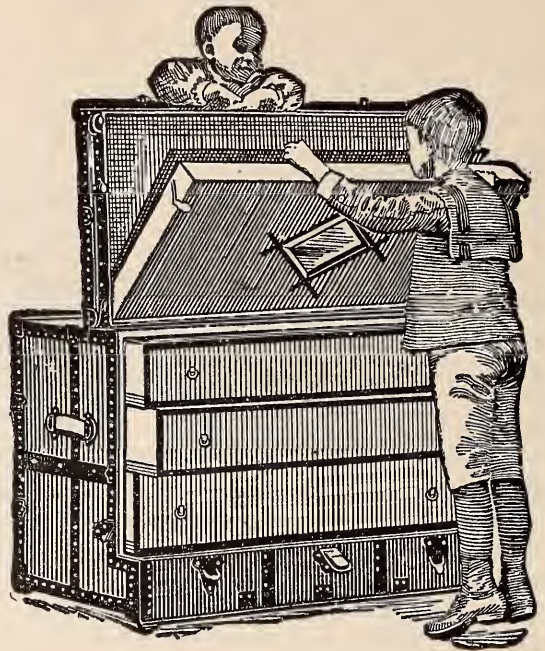

**Stallman's  
Dresser  
Trunk** Have you seen one? It is up-to-date. Think of it, everything within reach. No heavy trays, but light, smooth drawers. Holds as much and costs no more than a good box trunk. Hand riveted, almost indestructible. Once tried, always recommended. Sent C. O. D., privilege examination. **cc.** stamp for catalogue. Mention RECREATION.

F. A. STALLMAN,

87 W. Spring St.,

Columbus, O.

## DO YOU WANT A LENS?

If so, why not get a good one?  
And why not get it free of charge?  
This is easy.

Any old box will answer the purpose if it does not leak light; but you must have a fine lens to make a fine picture. You can get

### A Royal Anastigmat Lens, 4x5, Series No. 1

Made by the Rochester Lens Co., Rochester New York,

And listed at \$45,  
For 20 yearly subscrip-  
tions to RECREATION

You can get any other lens made by this Company on a basis of one subscription to \$2. of the list price of the lens.

Sample copies of RECREATION for use in soliciting furnished on application.

# THE Keeley Cure

**Alcohol,  
Opium,  
Tobacco  
Using**

Produce each a disease having definite pathology. The disease yields easily to the Treatment as administered at the following Keeley Institutes:

WHAT THE  
RT. REV. JOHN SHANLEY  
BISHOP OF NORTH DAKOTA, Says:

It is because I know it does save them, because I know it is God's truth that I take the deepest interest in the Keeley Cure, and so long as I live I shall raise my voice in advocating its efficacy.

Rt. Rev. JOHN SHANLEY,

Bishop of North Dakota.

Details of treatment and proofs of its success sent free on application.

ALWAYS ADDRESS THE INSTITUTE NEAREST TO YOU.

Birmingham, Ala.	Des Moines, Ia.	Omaha, Neb.	Providence, R. I.
Hot Springs, Ark.	Crab Orchard, Ky.	Cor. Leavenworth	Columbia, S. C.
Los Angeles, Cal.	New Orleans, La.,	and 19th Streets	Dallas, Tex.,
San Francisco, Cal.,	1628-38 Felicity St.	Buffalo, N. Y.	Bellevue Place.
1170 Market St.	Portland, Me.	White Plains, N. Y.	Richmond, Va.
West Haven, Conn.	Lexington, Mass.	Columbus, O.	Seattle, Wash.
Washington, D. C.,	Grand Rapids, Mich.	Portland, Ore.	Huntington, W. Va.
211 N. Capitol St.	St. Louis, Mo.	Harrisburg, Pa.	Waukesha, Wis.
Augusta, Ga.	Boulder, Mont.	Philadelphia, Pa.,	Toronto, Ont.
Dwight, Ill.	Fargo, N. D.	812 N. Broad St.	Winnipeg, Man.
Charlestown, Ind.	North Conway, N. H.	Pittsburgh, Pa.,	London, Eng.
Marion, Ind.		4246 Fifth Ave.	Cape Town, S. A.



Rev. T. DeWitt Talmage's famous lecture, "Evils of Intemperance," mailed on application. LESLIE E. KEELEY, M.D., LL.D.

**Free**—To each person sending me \$1 (post-office money order) for one year's subscription to RECREATION, I will send choice of a Braided Leather Dog Whip, with a steel snap on end, on a Polished Steel Dog Chain, with swivels, snaps, etc., or one dozen assorted Trout Flies, silk bodies, good ones, or a Pocket Compass, one inch dial, open face, watch shape, with ring handle and bevel crystal. Also a special offer limited to the months of June, July, August and September of a nickel plated multiplying 40 yard raised pillar reel, balance handle with click, drag and free running for two subscriptions. For four subscriptions a genuine 6 strip Split Bamboo or Fly Rod, 4 pieces with grips, silk whipped, nickel plated mountings, solid metal reel seat, length about 9½ feet.

Edward S. Adams,  
Box 536, Manchester, N. H.

I have always thought the Marlin the neatest rifle on the market, and I like its side ejecting feature; but the action is defective. I bought a Marlin 22, model '97, about 18 months ago. It has been shot about 1,000 times. From the first it would occasionally clog so I could not close the action until it was taken apart. It has become so bad now it can not be used as a repeater at all. I think the magazine spring has become too weak to push the cartridge entirely out of the magazine, so the shell can not rise when the lever is drawn back.

I can not understand why the Marlin Co. persists in sending out guns with such a defective action, when it could be so easily remedied by using an extracting hook similar to that in Winchester guns to draw the cartridges from the magazine. I like RECREATION. It is doing good work. I know it has helped me, and I intend to do all I can for it in return.

A. G. Bevan,  
Martinsburg, Ind.



**The "Victor"** is the real talking machine; its sound is natural. Band playing, monologues, comic or religious songs, all are reproduced as clear as if the artist was present. When ordering, **get the latest styles**—we charge no more than others who offer you old styles. Get our full catalogue FREE.

**E. L. Cuendet, 7 Barclay St., New York.**



## WEBBER'S JERSEY COAT

Costs no more than old-fashioned blouse to pull over the head. Designed for trap shooting in hot weather, but suitable for any purpose. Good thing for fishing, chicken shooting or office coat. Very light weight but strong and made to fit. Ask your dealer for it. If he does not have them, send me your size and price, \$2, and I will send you one to fit, charges prepaid.

**GEORGE F. WEBBER, MFR.**  
Station A, Detroit, Mich.

The Celebrated

# THOMPSON-QUIMBY

Hunting  
Boots,  
Shoes and  
Moccasins

THOMPSON

PSON

I have on file measurements of all who bought Boots and Shoes of the W. Fred Quimby Co., of New York for the past 20 years, and I make the same grade of sportsmen's footwear as they made. I was superintendent of the shoe department of that firm and bought the right to make these boots and shoes. Get a pair now. They will last years and are the cheapest in the end. I refer by permission to the Editor of RECREATION.

Measurement blanks and prices on application. Mention RECREATION.

**T. H. GUTHRIE**  
33 William Street, NEWARK, N. J.

All Work  
Guaranteed

The Marble safety axe you sent me as a premium was received in good order. It is a necessity in every sportsman's outfit.  
J. D. Fulwood, Brooklyn, N. Y.

The Wizard camera given me as a premium for subscribers to your valuable magazine is a fine one.  
L. L. Loomis, Cleveland, O.



## Music Boxes

For the Home, it is company at all times, will cheer you when you are sad; a veritable need when you are lonely; an accompaniment to your song, and play **Dance** music in **perfect time**. A boon to all music lovers. Our variety is great; prices to suit all. Our No. 20 costs only \$2.50, while our No. 191 runs in the hundreds. Complete Catalogues FREE.

**E. L. CUENDET, 7 Barclay St., New York**

**The Reason the LUTHER HAND-MADE GLOVE will not rip**

Machine sewing cuts itself

Hand sewing cannot.

## A Practical Hunting and Driving Glove

Made for practical, comfortable, durability. No Oil. No Odor. No Animal Glue. Practically seamless. Cannot Rip. Unaffected by moisture of any kind. If soiled, may be washed with soap and hot water, without injury. The Luther Fastener is adjustable, fits any wrist and cannot get out of order. Illustrated booklet, samples and self measurement rule on application.

If you prefer to buy through your dealer send us his name

**No. 308 Driving Glove** postpaid anywhere \$1.50, made to measure \$2.50,  
**No. 320 Gauntlet,** " " " 3

**J. P. LUTHER GLOVE CO., 536 Pearl St., Berlin, Wis.**

In a recent issue of RECREATION I read of the Marlin people refusing to send a spring to a man stranded in the woods. I wish to tell your readers of a courtesy extended to me by another arms company. I wrote asking the price of a mainspring to replace one I had broken. For answer they sent me the spring and a bill for same and credited me 2 cents for the stamp I enclosed for reply. That is the difference between dealing with a firm that tries to do the fair thing and one that does not. Have never owned a Marlin arm and do not wish to, as I never saw one that would work right.

I have also a word of caution for users of Winchester shot guns. Do not put oil in the action in cold weather. I oiled mine freely and started out to hunt bunnies one cold day. When the first rabbit got up I snapped 2 shells at him. When examined the primers were not even dented. The firing pin was locked with frozen oil. On trial, my companion discovered that his pump was frozen, too. By snapping the hammer repeatedly I finally freed the pin, but my friend's gun would not work until warmed. The next day I took the action apart, wiped everything dry and since then have had no trouble.

R. R. C., Rochelle, Ill.

**Free:** For 1 year's subscription of RECREATION, through me, will give 1 Bromide enlargement, any size up to 11 x 14 inches, inclusive, from any negative not larger than 4 x 5; or from photographs. Negatives and Photos are to be returned to the owner. Here is a rare chance to get a large Photo from your pet Negative, also RECREATION for \$1. A. F. Evarts, Meriden, Conn.

**White Mountain Views Free**

To any person sending me a subscription to RECREATION accompanied by \$1. I will send two mounted photos, on velox paper taken among the White Mountains, size 6x8; one shows Mt. Washington snow capped. To any one sending 2 subscriptions with \$2 I will send a souvenir of the White Mountains, size 4½ x 5½ containing seven photos. Send P. O. Money Order.

M. E. TUTTLE, Box 337 Dover, N. H.

**FREE BOOK, WEAK MEN**



My illustrated nature book on losses varicocele, impotency, lame back, free sealed, by mail. Much valuable advice and describes the new DR. SANDEN HERCULEX ELECTRIC BELT. Worn nights. No drugs. Currents soothing. Used by women also for rheumatic pains, etc. 5,000 cures 1902 Established 30 years. Advice free.

DR. G. B. SANDEN,  
1155 Broadway, N. Y.

**Rupture=Varicocele=Hydrocele  
Resulting Nervous Diseases**

New discoveries regarding their scientific treatment are described and illustrated. The book is sent sealed for ten cents.

D. D. RICHARDSON, M. D.  
Suite 622, 123 Michigan Avenue, CHICAGO

**ARE YOU GOING BLIND**

Or in Any Way Troubled  
With Your Eyes?

Write to Dr. Oren Oneal, the Noted  
Oculist of Chicago



Do not allow yourself to go blind. This well known specialist, by his absolutely new method of painless home treatment, known as the Oneal Dissolvent Method, is able to prevent blindness and to cure all diseases and defects of the eyes. His success is attested by thousands of cured cases in all parts of the world whose names are available to inquirers as personal reference.

**TEST YOUR EYES**

- Do you see objects as through a haze?
- Does the atmosphere seem smoky or foggy?
- Do spots or specks dance before the eyes?
- Do you see more clearly some days than others?
- Do you see better sideways than straightforward?
- Do you see better in the evening or just after sundown?
- Does a candle or street lamp seem expanded into a large flame?
- Does a lamp or electric light seem to have a halo about it?
- Do luminous objects like the moon seem to be double or multiplied?

Any one of the above symptoms indicate a grave affection of the eyes which will result in blindness if not attended to very soon.

Any case of blindness or any other eye trouble can be successfully treated by Dr. Oneal at patient's own home, quickly and at small expense.

Among Dr. Oneal's recent notable cures are the following: H. S. Davis, 211 Colchester St., Burlington, Vt., cataracts; Mrs. A. P. Rifle, 78 Niagara St., Buffalo, N. Y., cataracts; Carlton Hughes, 316 B St., S. W. Washington, D. C., cataracts; Mrs. H. Burdick, Richland Center, Wis., hemorrhage of retina; Mrs. C. H. Sweetland, Hamburg, Ia., paresis of the optic nerve. These people cured themselves at their own homes, as have thousands of others.

Write for illustrated book which gives detailed information, references and testimonials. It is sent free to any one who is interested enough to ask for it. Dr. Oneal will also be pleased to give a written opinion on any case of eye disease. Address

**OREN ONEAL, M. D.,**  
Suite 839. 52 Dearborn St., Chicago, Ill., U. S. A.

RELICS OF A DISAPPEARING RACE

# Buffalo Skulls

WITH POLISHED OR UNPOLISHED HORNS

Also polished or unpolished horns in pairs or single. Polished horns tipped with incandescent electric lights; polished hunting horns; mirrors hung in polished horns, etc. These are decided novelties and are in great demand for sportsmen's dens, offices, club-rooms, halls, etc. Send for illustrated catalog. Mention RECREATION.

E. W. STILES

141 Washington St. Hartford, Conn.

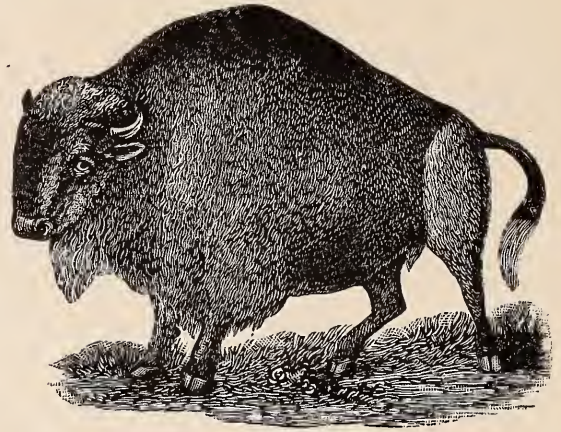

## SPORTSMEN--Learn Taxidermy by Mail.

No sportsman is properly equipped to enjoy hunting and fishing unless he is able to mount his beautiful trophies. Our school has the hearty endorsement of leading sportsmen and naturalists everywhere. Everything included by the term Natural History, taught with **entire success** by correspondence. **Just what you need and have always wanted.** Best of methods. **Tuition very reasonable.** We want to tell you all about it. Write today for FREE Catalog. Mention RECREATION. Our school was organized for your benefit.

### THE NORTHWESTERN SCHOOL OF TAXIDERMY

411A Bee Bldg.

OMAHA, NEBR.

## High-Bred Pointers

I have six high-bred, thoroughly well broken black and white pointers for sale.

They are two years old and eligible to registration—King of Kent strain, sired by Hal Pointer.

They are staunch on point, tender retrievers, wide rangers, good bird finders, strong and healthy, of good disposition, and steady under the gun. Every dog guaranteed.

Photograph and copy of pedigree furnished on receipt of 10c. to cover postage.

**Dr. W. A. Dorland**  
Grand Rapids, Mich.

## For Want of Cash Must Sell Quick

10 pair of Wood Ducks, 15 pair of Blue Wing Teal, 10 pair of Green Wing Teal, 14 pair of Garganey Teal, 10 pair of Pintails, 5 pair of Shovellers, 10 pair Gadwalls, 20 pair Wild Mallards, 20 pair of Gray and White Calls, 5 pair of Black Ducks, Trio of Brant, 3 pair white Swans (European) \$30; 50 Mongolian, Ringneck, Chinese Hybrid, Silver and Golden Pheasants; 1,000 pair of Imported Homers for Squab breeding; 50 Imported Runts, 20 pairs imported Peafowls. Book on Pheasant keeping and Squab raising. Send 2 stamps for my booklet that tells "HOW TO MAKE MONEY" breeding Squabs, Pheasants and Quail. I want to buy all kinds of Live Animals, Wild Ducks, etc.

GENEI DeGUARDINER, Natick, Mass.

## Squab Book Free



Squabs are raised in 1 month, bring big prices. Eager market. Astonishing profits. Easy for women and invalids. Use your spare time profitably. Small space and capital. Here is something worth looking into. Facts given in our FREE BOOK, "How to make money with Squabs." PLYMOUTH ROCK

SQUAB CO., 11 Friend St., Boston, Mass.

## Taxidermists' Glass Eyes for Stuffed Birds and Animals

Oologists' and Entomologists' Supplies

## Materials

Send 5c. in stamps for catalogue

FRED. KAEMPFER, 88 STATE ST., Chicago, Ill.

Taxidermy work done in all its branches  
Mention RECREATION

For Sale. The largest collection of Game Heads, Horns, and Antlers in America. A total of TWO HUNDRED AND FIFTY SPECIMENS, including many record heads and exceptional freaks and rarities. Full information and catalogue on application.

A. E. COLBURN,

Bond Building, Washington, D. C.

## FLORIDA BIRDS.

I have on hand a fair assortment of our Native Bird Skins, suitable for schools, museums or private collections.

During the season of 1903 I will collect any birds or mammals to order.

Finest mounted work a specialty.

R. D. HOYT, Taxidermist,  
SEVEN OAKS, FLA.

## Cavies or Guinea Pigs

Peruvian, Abyssinian or English Long or Short Haired. All colors, 400 to select from.

T. RACKHAM,  
East Orange, New Jersey.



FINE MOUNTED GAME HEADS, BIRDS, ETC., for sale at unheard-of prices. Send 10 cents for photos. JOHN CLAYTON, Taxidermist, Lincoln, Maine

I see that the article I wrote for RECREATION in May, 1901, in regard to Peters shells not working properly in a Winchester repeating shot gun, fore arm action, has provoked a controversy. Some condemn me and say I do not know what I am talking about, but I am pleased to note that the majority of sportsmen are with me.

I repeat my assertion that the Peters shells are not practicable for use in the above mentioned arm. I have tried them repeatedly, only to have 2 shells enter the magazine at once, thereby blocking the action. The U. M. C. cartridges are good enough for me. In fact they are the best I have ever found. As long as the Peters people act in the present childish manner towards you and RECREATION, I don't want their cartridges

C. S. Radcliff, Cincinnati, O.

**The Best Offer Yet.**—To any person who will subscribe to RECREATION for one year through me I will send free a small water color landscape, hand painted, suitable for framing; or a hand painted silk bookmark. For two subscriptions I will send a fine Mexican opal scarf pin worth ordinarily from \$1 to \$1.50.

Don M. Harris, 308 Crawford Road,  
Cleveland, Ohio.

## The Buffalo Is Well Nigh Extinct

And every nature lover wants a relic of him. Here is a chance to get it:

I have in stock a limited number of buffalo horns, highly polished and fitted with nickel plated flanges at the base, so that they can be screwed on the wall, thus forming

## A Novel and Effective Gun Rack

So long as the supply lasts I will give a pair of these horns for

### 3 Yearly Subscriptions to RECREATION

Sample copies for use in canvassing furnished on request. Address

Recreation, 23 W. 24th St., New York

## Dress for Comfort



### Because of their construction **PRESIDENT SUSPENDERS**

give most

### Comfort & Service

*Guaranteed* "All breaks made good"

"President" on buckle means

"Cannot rust" 50c. and \$1.00

Any shop or by mail prepaid

The C. A. Edgerton Mfg. Co.

Box 219 O, Shirley Mass

Send 6c. for Catalogue

## SQUIRES' SIBERIAN MOOSE HUNTING BOOTS & SHOES

Made only by **HENRY C. SQUIRES & SON**  
20 Cortlandt St., New York

The **leather** is waterproof, fine grained, tough and pliable. The

**linings** are russet calfskin. The **soles** are

best waterproof anhydrous oak leather,

**stitching** of silk, English back stays, bulldog

toes, extra heavy **eye-**

**lets, Pratt fasteners**

and **hand made**

**throughout.** Price

**\$7.50** net. Short Boots

**\$8.50**, Knee Boots

**\$10**, Cavalry Style

Boots **\$12.**

Special circular

giving detailed

information

free for the

asking.



Mention RECREATION.

---

STILL ANOTHER GREAT OFFER

# A Grade OO Syracuse Gun

*Listed at \$30.*

FOR

*25 Yearly Subscriptions*

TO

## Recreation

If you Want one of the Guns get a move on you

Sample copies for use in canvassing  
furnished on application

---

---

**RECREATION, 23 W. 24th Street, New York**



# THE "BRISTOL"

## STEEL FISHING RODS

HAVE BECOME A STAPLE NECESSITY.

As they are made in twenty-five different styles and sizes weighing from 6½ to 11½ ounces, there is a wide range of choice. Fisher-men—and women, too—are delighted with their action, and are pleased to recommend them. Send for our FREE CATALOGUE, and learn what it tells—then buy a rod and see what it will do. Address

**The Horton Mfg. Co.**  
 No. 73 Horton Street,  
 Bristol, Conn.



THE "BRISTOL" ROD DID IT—  
 WITH THE YOUNG LADY'S AID.



# This is "Pardner"

and the 15 lb. Rainbow trout caught by "Pardner's" partner, "El Comancho," in the Skykomish River, Wash., on May 14th, last,

*Landed with a*

## "Y & E" AUTOMATIC REEL

The only Automatic Reel with free running feature, and therefore the only perfect reel for fly-and-bait-casting. Special prize of \$20.00. will be given for biggest Rainbow trout caught during 1903. Are you in? Write to-day for contest blank showing five other money prizes and handsome catalogue 299 R.

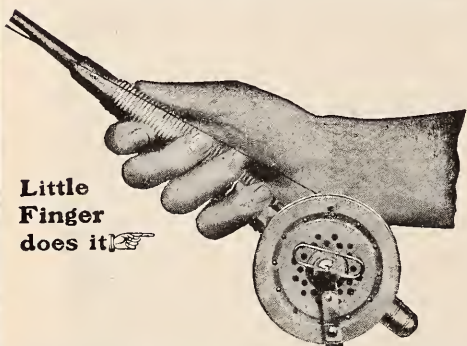

**YAWMAN & ERBE  
MFG. CO.  
ROCHESTER, N. Y.**

"PARDNER."

### Small Profits—Quick Sales

# TROUT FLIES

for trial—send us



- 15c for an assorted sample doz. Regular price, 24 cents. **Quality A Flies**
- 30c for an assorted sample doz. Regular price, 60 cents. **Quality B Flies**
- 60c for an assorted sample doz. Regular price, 84 cents. **Quality C Flies**
- 60c for an assorted dozen Bass Flies. Regular price 84 cents. **Bass Flies**

## SPLIT BAMBOO RODS

Fly Rods **57 cents** Bait Rods  
10 feet, 6 ounces 9 feet, 8 ounces

With cork grip and extra tip, in wood form

Try our new Braided Silk Enameled Waterproof

## METAL CENTER LINE

Size No. 5, 4½ cents per yard. Size No. 4, 5½ cents per yard  
Put up in 10-yard lengths connected.

**THE H. H. KIFFE CO.**  
**523 Broadway, New York City**

Catalogs of any of above goods free on application.  
Mention RECREATION.

### Do you enjoy big game hunting? Or Trout Fishing? Or Mountain Climbing?

If so, write us and we can accommodate you.

We keep 65 head of horses. We employ a full corps of experienced guides, packers, and cooks.

We have a complete outfit of riding saddles, pack saddles, tents, stoves, cooking utensils, tableware, and everything necessary for touring and camping in the Mountains.

We live at Banff. The Eastern gateway of the Canadian Rockies.

And can send you anywhere you may wish to go from this point

*North, East, South or West.*

**Address: BREWSTER BROS.  
Banff, Alberta, Canada.**

### A DOLLAR RATE BOOK FREE To Advertiser

We will send postpaid, entirely without charge, to any business house that is interested in the subject of advertising, a copy of a bound volume we have recently issued entitled "Current Rates of Live Publications," giving list of leading towns throughout U. S., populations, principal papers, circulations and publishers' rates for advertising space on small and large contracts. Regular price of this volume is \$1—We will send free upon receipt of ten cents in stamps to cover postage.

**FULFORD, PAINTER & TOBEY, Inc., Advertising Agents**  
N. W. Cor. Wabash Ave. and Randolph St. CHICAGO, ILL.

**A Hunting Knife Free.** To any person sending me three yearly subscriptions to RECREATION and \$3, I will send a pocket hunting knife with handle 5½ inches long and blade 5 inches long. Fine steel, excellent workmanship. Your name and address and your L.A.S. number if desired inserted on a plate in the handle.

**Geo. W. Mains, McKeesport, Pa.**

## Are You an Amateur Photographer ?

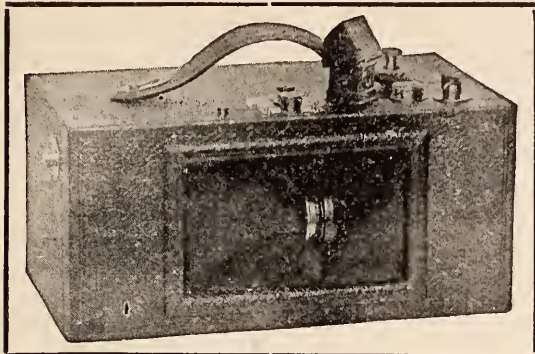

If so, would you like a Camera  
that will photograph

**A** whole range of mountains  
whole sweep of river  
whole army  
whole fleet of ships  
whole city

Or any other stretch of scenery or moving  
objects. THE SWING LENS DOES IT

## The Al Vista

Is the thing. It Lists at \$30

One of the greatest inventions of the age.  
Given as a premium for 12 subscriptions.

FOR PARTICULARS ADDRESS

RECREATION, 23 W. 24th St., N. Y.

### REMARKABLE OFFERS

To every person who will send RECREATION \$1 for 1 year's subscription to be placed to my credit I will give as a premium a choice of a Nickel Plated Match Safe, or a Gilt Metal Match Safe, or a Hard Rubber Water Proof Match Safe, each listed at 40 cents; or a Nickel Dog Whistle and pocket drinking cup, listed at 50 cents; or a Nail Clipper, with file and Nail Clipper attached, listed at 40 cents; or a 25 yard Single Action Reel, listed at 40 cents; or a 25 yard Water Proof Silk Line, listed at 50 cents.

For 2 subscriptions a Hunting Knife, Stag Handle, Blade 5½ inches long, listed at \$1.

For 3 subscriptions a Patent Double Minnow Bucket, listed at \$2; or a 60 yard Multiplying Reel, listed at \$2; or a 3-piece Bamboo Rod, 7 or 9 feet long, listed at \$2; or a Heavy Silk Watch Fob, listed at \$1.50.

For 5 subscriptions a fancy striped Hammock, listed at \$3; or a Hunting Knife, listed at \$3; or a Tackle Box, listed at \$3.

For 9 subscriptions a field glass listed at \$6.

Only a limited number of subscriptions can be accepted on these offers.

E. W. Jacobs, Coshocton, Ohio.

IN ANSWERING ADS PLEASE  
MENTION RECREATION,

## The KHOTAL BLUE FLAME

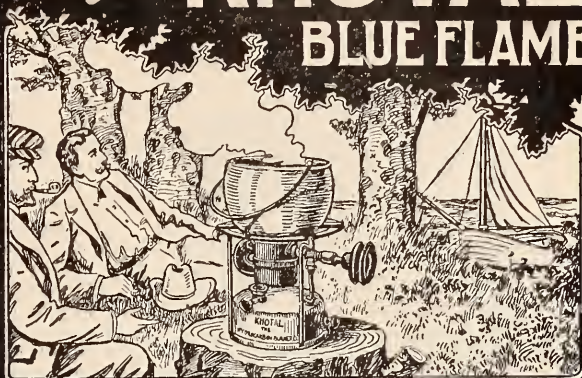

THE Khotal Blue Flame Oil Stove is the best stove for any one indulging in the pleasures of outdoor life. Absolutely non-explosive. Light and portable, requires little attention, and does not smoke, smell, or soot. No wicks. Produces any temperature of heat; simple in operation, and with ordinary care will last for years. Indispensable to yachtsmen and campers. Made in different sizes at prices from \$3.75 up. Send for our illustrated catalogue, quoting sizes and prices.

**KHOTAL BURNER COMPANY**

197 Fulton Street, New York

## IT NEVER FAILS The S. & W. Artificial Bait

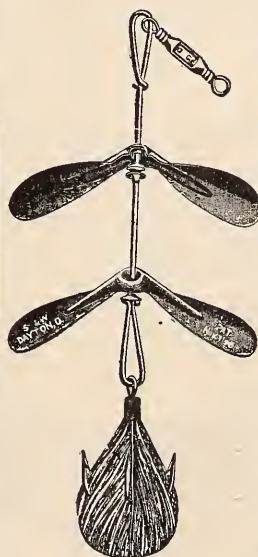

Is the most successful  
bait made.

When in motion it resembles a minnow so closely that it never fails to delude the fish.

Its construction makes it almost impossible for a fish to strike and not get caught

### A GREAT SELLER

Do you fish? Buy one. You will never be without one afterward.

Why? It will catch fish. Can be used with rod or hand line.

Dealers send for illustrated booklet and get our prices.

If your dealer cannot supply you, send 50c.  
at once for one (post paid) to

**STARK & WECKESSER**

57 S. Main St. : : : DAYTON, OHIO, U. S. A.

# Fisk's Aerating Minnow Pail



The only Minnow Pail in which Minnows can be kept alive indefinitely.

Has an air chamber at the bottom holding 26 cubic inches of condensed air forced in by the Air Pump attached, and by a simple rubber attachment the air is allowed to escape into the water gradually supplying the fish with the oxygen consumed by them. One pumping is sufficient for ten hours.

Height, 1 foot; diameter, 10 inches; weight, 7½ lbs.; water, 2½ gallons; keeps 50 to 150 minnows, according to their size.

**IT KEEPS THEM ALIVE**

Send for circular Mention RECREATION

**J. M. KENYON & CO.**  
214 Twelfth St., Toledo, Ohio, U. S. A.

# S L E E P

IS TIRED NATURE'S  
SWEET RESTORER

After a hard day's tramp, you must have

## A GOOD NIGHT'S REST

in order to fit you for the next day's work.

Better to sleep on a good bed without your dinner, than sip at a banquet and then sleep on the cold, hard, wet ground.

You can get

## A Recreation Camp Mattress

of rubber, with valve for inflating, made by the Pneumatic Mattress Co. and listed at \$18

For 15 Yearly Subscriptions  
to RECREATION

Send for Sample Copies

Address RECREATION, 23 W. 24th Street, New York

## THE BRISTOL AS A SALT WATER ROD.

There are 2 articles advertised in RECREATION that I should like to say a word about: the Shakespeare Revolution bait and the Bristol rod. The rod, a No. 11 Henshall, I have used the last 2 seasons, and want no better. When I first appeared with this rod on a fishing trip to waters near the Gulf of Mexico, a friend, an angler of experience, said there was no better rod made, but that several he had used in that particular locality had rusted inside and broken. Acting on this hint, I cleaned my rod thoroughly by means of a cleaning wire prepared for the purpose, and then coated the interior with a gun grease that I knew from experience would prevent rust. Then I fitted plugs in the open ends, and pushed them down into the rod until there was just enough room to receive the ferrules where the rod was jointed. By care I have kept all rust from the exposed portion in the ferrule seats. These seats are cleaned after every day's fishing.

So much for the interior. I scraped all the enamel off the outside of the rod, as I found it could be chipped in use. A fresh coat of enamel was then applied, and when this had dried sufficiently to become sticky, fine silk thread was wound the whole length of the rod. This was readily accomplished by placing the spool of silk on a sewing machine, drawing the silk through the tension, and after starting the winding, completing the job by rotating the rod in my fingers, so as to wind the silk evenly. An alcohol flame carefully applied to the silk burned off the fuzz or nap, when a coat of enamel was laid on smoothly. Of course, care was taken not to scorch the silk.

The appearance of the rod is just the same as before, the weight has not been increased a quarter of an ounce, and the rod is good for any kind of exposure. I use mine in salt water without having any trouble with rusting.

The Revolution bait also can not be praised too highly. In order to see how it worked mechanically, I threw it out from shore about 10 feet and slowly drew it in. The result so startled me that I jerked the bait out of water and over my shoulder, as a bass struck at it with a tremendous splash. A second cast immediately hooked my fish. My experience since that first trial convinces me that if a bass is in sight of the bait he will strike at it. It is just right in weight for casting with the Bristol rod.

R. R. Raymond, Montgomery, Ala.



**INDIAN  
CURIOS**

WHOLESALE & RETAIL  
CURIO DEALERS'  
SUPPLY DEPOT.

Bead Work, Baskets, Elk Teeth, Mexican Goods, Fossils, Minerals, Arrow-Heads, Pottery, Alaska Ivories, Shells, Agates, Photos, Great stock, Big Cata. &c., stamps. Mention RECREATION. If a dealer, say so.

**L. W. STILWELL**

DEADWOOD      SO. DAKOTA



# THE LATEST, SAFEST AND BEST CANVAS BOAT

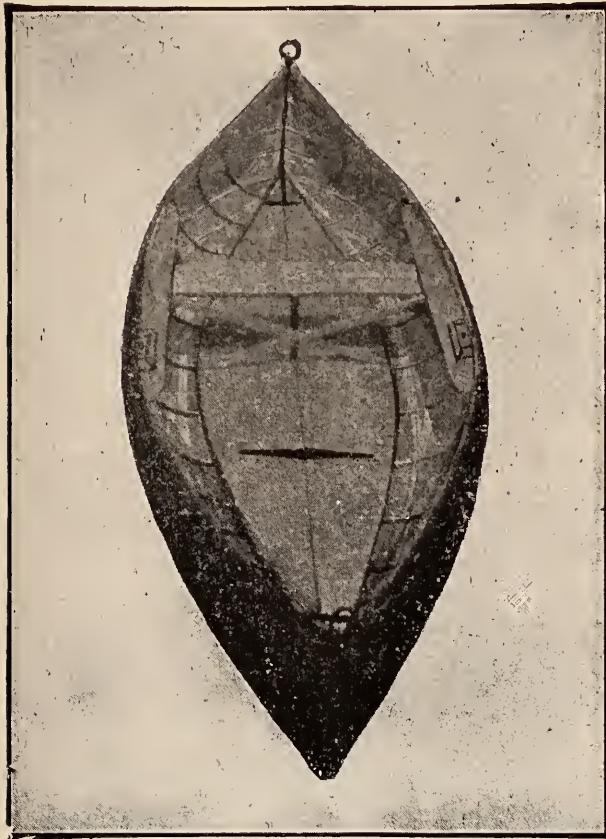

Is what we offer you. A Boat built on modern lines that will prove a pleasure to own and use. Selected materials used throughout, and it comes to you **guaranteed** the best. A handy and safe boat for fishing and shooting. Send 4 cents in stamps for catalogue and reliable testimonials.

Mention RECREATION.

**LIFE SAVING FOLDING CANVAS BOAT CO.**  
Kalamazoo, Mich.



Latest patent and improved Canvas Folding Boat on the Market. Puncture proof. Tempered steel frame. No bolts to remove. Folds most compact of any boat made.

## THE HILDEBRANDT SPINNER



For Fly Fishermen. A spinner which spins, and also catches fish. Strictly hand-made and of the best material. No swivel required. Made with all kinds of Feather and

Buck-tail flies. For sale by dealers. Sent on receipt of 25c.

**J. J. HILDEBRANDT, Logansport, Ind.**

For Sale: Smith & Wesson revolver, 44 Russian caliber, 6 inch barrel.

4x5 Pony Premo, No. 5. Both good as new. For particulars write J. P. Allen, Jr., Greencastle, Ind.

## MARINE GAS ENGINES

Experts for years have ranked our engines with the highest grade, and it is now being copied by other builders. We always endeavor to be on top and for 1903 offer an engine built from brand new patterns, with **NEW** and **ORIGINAL** features—just what other engines will have five years hence.

If you want to be in the lead send for catalog fully describing all parts, and then buy a "Rochester".

**ROCHESTER GAS ENGINE CO.**

700 Driving Park Ave. Rochester, N. Y., U. S. A.

**Wanted**—Close range photos of wild birds, mammals and reptiles in Nature (the commonest species of the Eastern U. S. excluded). Good prices for satisfactory pictures. Abbott H. Thayer, Monadnock, N. H.

## Points on Angling

More complete than ever before

The Habits and  
Haunts of

# GAME FISH

and How to Catch Them

Mailed free on application

**THE SPECIALTY MFG. COMPANY**

Box 62a, Goshen, Indiana

## CAMPERS



Here is what you need. A powerful, compact **Electric Flashlight** to carry in the pocket.

The hardest storm cannot blow out this light. Just press the button and you have it instantly without noise or delay. Brilliantly lights up hollow tree, burrow or cave.

Safe in the stable or hay loft where lamp or candle would be dangerous. Never out of order.

Price, **\$2.00**. Good for **5,000 flashes**; then a new battery for 30 cents. Send for Catalogue.

**American Electrical Novelty and Mfg. Co.**  
Dept. A—Hudson & Spring Sts., NEW YORK  
Dept. H—Masonic Temple, CHICAGO

# Mullins' Metal Boats



**"Get There" Duck Boat** in use. Be sure and order one for your Fall shoot. Approved by sportsmen wherever used. Send for catalogue, with prices, etc. Mention RECREATION.



**"PRINCE."** 14 ft., square stern model. Especially adapted for family and livery use.

\$30 crated on cars, Salem.

**W. H. MULLINS**

228 Depot St.

Salem, Ohio

**For Sale:—** WINCHESTER REPEATING RIFLE, Model '94, 30-30, with Lyman sights, and complete reloading set Ideal tools, for 30-30 Short-range, Kephart bullet. Outfit in fine condition. Thos. Branch, Jr., Pine Grove Furnace, Cumb. Co., Pa.



**BULLARD STEEL LAUNCHES,**  
ROW AND PLEASURE BOATS,  
**ARE EVERLASTING!**

Safer than wood; have greater carrying capacity; always dry; no bolts or nails to rust.

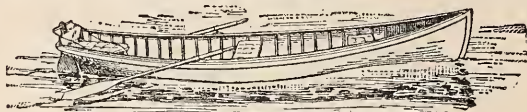

Boat Liveries equipped with the Bullard Steel Boats. Always have dry boats, that last a lifetime.

**STEEL BOATS CHEAPER THAN WOOD.**

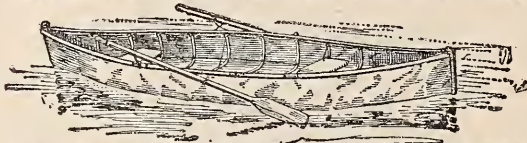

**THE OSGOOD FOLDING CANVAS BOATS**

Original Canvas Boat; made for 30 years. Sold all over the world; used by U. S. Government; best Fishing and Hunting is where there are no boats, take one with you in trunk or bag. Non-puncturable. Folded or extended in one minute.

Send for catalogue illustrating all improved popular designs of Steel, Wood, and Canvas Boats, and Marine Engines.

**MICHIGAN CONSOLIDATED BOAT CO., LTD.**

55 Main St., Battle Creek, Mich.

**For Sale:** New 30-30 Winchester carbine. Half magazine, shot gun, butt stock. Perfect condition, with cleaning tools, 40 cartridges. \$12. No trades. Charles J. Campbell, Englevalle, North Dakota.

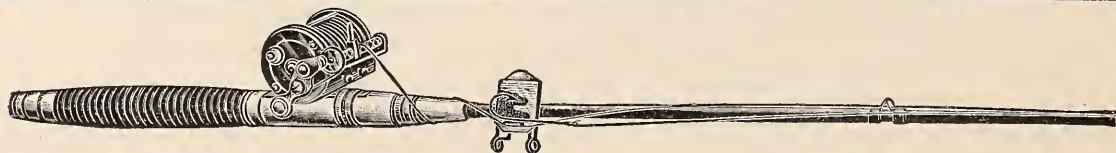

**T**HE above cut shows our **INDEPENDENT EVEN SPOOLING DEVICE** that level winds your line on the spool of the reel, and also shows our **SPRING LOCK HOOK SHIELD** that muzzles and locks to the pole that dangling hook when not in use. We also make the Lightning Fish Scaler. Our prices are quoted in April, May and June numbers of RECREATION.

Descriptive Catalog free on request. Mention RECREATION.

**A. W. BISHOP & SON,**

**Racine, Wis.**



**ACME FOLDING BOAT CO., MIAMISBURG, O.**

U. S. Government who prefer our boats. Received medal and award at Chicago World's Fair. If you investigate we will get your order. Mention RECREATION.

**Acme Folding Boat Company, Miamisburg, O**

**D.M. TUTTLE CO. 10 PINE STREET CANASTOTA, N.Y. CATALOGUE FREE.**

**BREAK SPARK GASOLINE ENGINES & LAUNCHES. JUMP SPARK.**



11-foot Special

Folding Canvas Boats were not satisfactory until the **King** was produced. **It's a revelation** in boat construction. Nothing like it ever made. **Nonsinkable. Can't tip over. Puncture-proof.** Wear longer than a wooden boat. **No repairs.** No cost for storage. **Always ready.** Folds into a small neat package,—**carry by hand.** Used by the U. S. Navy. They are simply wonderful. A thoroughly patented article. Beware of imitation. Made only by ourselves.

A catalogue of 70 engravings and 350 testimonials sent on receipt of 6 cents.

Mention RECREATION.

**King Folding Canvas Boat Co.**  
Kalamazoo, Mich., U. S. A.

## To Amateur Photographers

Here is a Chance to Get a  
**FINE CAMERA EASILY**

A 4x5 Tourist Hawk-eye film camera listing at \$8, for 5 yearly subscriptions to RECREATION. A No. 3 folding Weno Hawk-eye film camera, listed at \$15, for 10 yearly subscriptions to RECREATION.

These are both neat, compact, well made and handsomely finished cameras, capable of doing high-class work.

*Sample copies for use in canvas-  
sing furnished on request.*

Address **RECREATION,**  
23 West 24th St. New York City.

# RUSHTON CANOES

Cannot be Beat

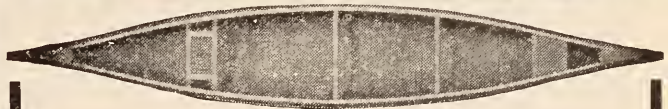

Indian Girl Model 15, 16, 17, 18 Feet

Northern White Cedar, Canvas Covered, \$30 to \$43

"There is a pleasure in the pathless woods"—but it is second, in the minds of many men, to that found on the smooth surface of lake and river, when fishing, hunting or idling in a staunch, swift, graceful Rushton-built canoe. 29 years' experience goes into every one that I turn out, and guarantees the quality.

Have you secured one for your vacation?

*Write for my complete catalogue of pleasure boats, canoes and fittings—sent FREE.*

**J. H. RUSHTON, 817 Water St., Canton, N. Y.**

# FAY & BOWEN Motors & Launches

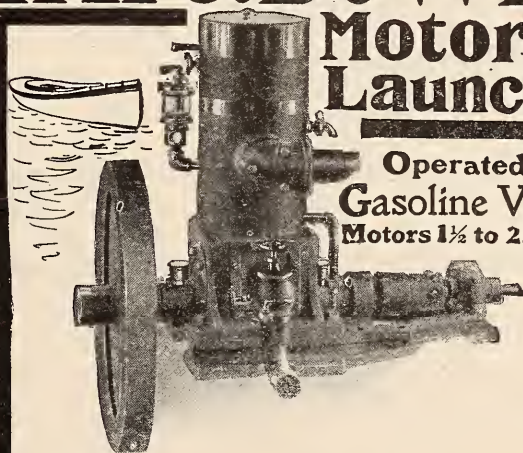

Operated by  
**Gasoline Vapor**  
Motors 1½ to 25 H.P.

**T**HE Fay & Bowen Marine Motor is a revelation to those who have used others. Reliable, safe, durable and easy to operate. Remarkable speed control. Best of all, it starts when you start it. No handle or crank is used. Our patent igniter is absolutely unique and always instant and positive in action. It is really the only perfect and satisfactory igniter.

Motors complete from 1½ to 25 H. P. ready for installation. We also build handsome launches with motors installed and ready to run

*Send for Catalogue.*

**Fay & Bowen,**  
28 Mill Street, Auburn, N. Y.

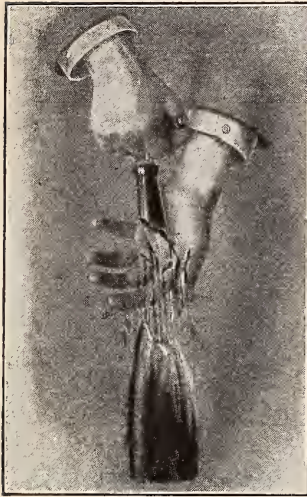

## THE Yankee Cork Puller

Yanks the cork from any bottle as quick as you can move your hand up and down. Leaves the bottle clean and free from broken bits of cork. Never breaks the bottle. Don't let your wife or servant run the risk of blood poisoning by cutting their hands on a bottle broken with an ordinary corkscrew. The Yankee lasts a lifetime, fastens against the refrigerator, door jamb or any upright surface, and is always in place, and costs but

**\$1.25 Nickel Plated Buy One Now**  
**\$3.50 Silver Plated**

May be returned after thirty days trial and money back if not pleased. If your Hardware Dealer hasn't it, write us.

**THE GILCHRIST CO., 125 Lafayette Street, Newark, N. J.**

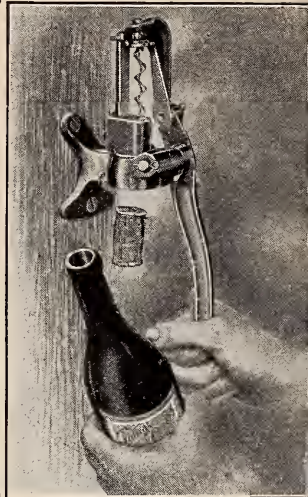

**To RECREATION Readers:** I am organizing a club of subscribers for RECREATION, with a view to securing a premium, and I submit this offer; to each person sending me \$1 for yearly subscription to RECREATION, I will send a 25c. Dominion of Canada bank note. There are but a few of these in circulation and I have succeeded in collecting a number of them. These are interesting souvenirs and are especially valuable to persons who are making collections of coins or other curios. Walter Legare, 518 John St., Quebec, Can.

**Another Good Offer:** To the first person sending me five subscriptions to RECREATION and five dollars, before April 1st, I will give a 2 by 3½ printing press, and type to go with it. To any person sending me two subscriptions and two dollars I will give a silver-plated napkin ring. To any person sending one subscription, I will give a sterling silver ring. All persons sending me one subscription, please send finger measurement. A. J. Brodhead, 42 Sayre St., Elizabeth, N. J.



No bewildering array of levers, gauges or other intricacies—one hand does it all. A *twist* of the *wrist* not only steers it, but accelerates or retards the pace from a position of luxurious ease. **THE DURYEA PHAETON** is the acme of motor carriage perfection. Its long springs and large wheels obviate all jar and give greatest possible comfort. No machinery in front to annoy passengers by odor, or in sight to mar appearance. The result of twelve years' experience of the oldest motor vehicle builders in America. Triple Gasoline Motors. Speed up to 40 miles per hour. Fuel for 100 mile run. Large bronze bearings.

**Duryea** vehicles are most durable and economical in fuel and tires of any built. **No pumps, no trouble.**

**Duryea's** excel under all conditions. Fastest American gasoline carriage, Nelson Hill, 1901; won Chicago Times-Herald 50 mile race through more than a foot of snow, and other races in Europe and America. They lead the way today.

Send for catalogue of the eight styles—also booklets. They will interest you.

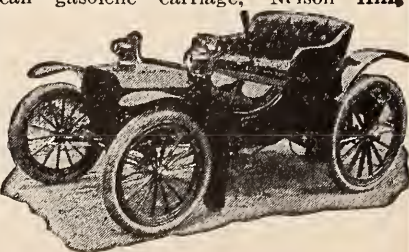

**DURYEA POWER CO., 314 Hockley St., Reading, Pa.**

El Paso, Texas.  
The Peters Cartridge Co.,  
Cincinnati, Ohio:

Dear Sirs:—I see in May RECREATION that you have canceled your ad in that magazine. You have done wrong. Mr. Shields should not be held responsible for the opinion of his contributors. I have heard experienced sportsmen say that the Winchester rifle is inferior to others, and so on, but people will continue to have their choice in such matters and buy the guns and ammunition that suit them best.

All true sportsmen love Mr. Shields for the great missionary work he is doing for game protection, without which there would soon be no use for cartridges, and you would have to go out of business. For this reason, if for no other, all sportsmen will stay with him, to the financial hurt of you or anyone else who makes a fight on him, on so flimsy a pretext. I have used your cartridges and like them, but there are others; hence I feel it my duty to use goods made by men who do not see fit to withdraw their ad each time someone criticises their goods.

Dr. I. J. Bush.

Burglar (throwing up his hands)—All right, boss, I'll go to th' p'leece station wit' ye.

Suburban Resident—No, you won't! you'll stay and visit with us. We haven't had a caller for a month.



# “Be sure it's an Ostermoor”



**I**NGENIOUS imitations of our trade mark abound. Do not tolerate the “just as good” cry of a fraudulent dealer. It's not “felt” if it's not an Ostermoor, so—**be sure it's an Ostermoor.** Our *name and trade mark label* on the end of every genuine mattress. Why not learn about the Ostermoor, even if you don't want a mattress now. We have spent thousands of dollars to issue our handsome 96-page book, “The Test of Time,” handsomely illustrated, which

## We Will Send You Free.

Each copy costs us 25 cts. to print and 5 cts. in stamps to mail—it is yours for your name on a postal. Send to-day. The Ostermoor is the best mattress ever made—a glance at the letters in our book will prove it—but this guarantee should suffice:

#### STANDARD SIZES AND PRICES:

2 feet 6 inches wide, 25 lbs.,	- - -	\$ 8.35
3 feet wide, 30 lbs.,	- - -	10.00
3 feet 6 inches wide, 35 lbs.,	- - -	11.70
4 feet wide, 40 lbs.,	- - -	13.35
4 feet 6 inches wide, 45 lbs.,	- - -	15.00

All 6 feet 3 inches long.

In two parts 50c. extra. Special sizes, special prices.

Express charges prepaid to any place.

#### THIRTY NIGHTS' FREE TRIAL.

You can have an Ostermoor Mattress, sleep on it thirty nights, and if it is not better than any other Mattress you have ever used—if it is not all you even HOPED for, return it at our expense and your money will be immediately refunded without question. What more can we do to convince you?

**Ostermoor & Co., 114 Elizabeth Street, New York.**

Canadian Agency: The Alaska Feather and Down Co., Ltd., Montreal.

**For Shot Guns**  
 USE

**Robin Hood**

**IT LEADS THEM ALL**

IN PATTERN  
PENETRATION  
CLEANLINESS



IN QUALITY  
UNIFORMITY  
PRICE

**S M O K E L E S S**

Fair and impartial comparative tests will convince you of these facts. Write for Powder Facts. Mention RECREATION.

**The Robin Hood Powder Co.**  
Swanton, Vt.

**100 STRAIGHT**

Amateurs as well as Experts make and break records with

**DuPont Smokeless**

At Baltimore, Md., June 3d, Mr. Howard D. Jackson won the county amateur championship of Maryland. He broke 100 straight, using 38 grains of DuPont Smokeless, 1¼ oz. 7½ chilled shot.

**100 STRAIGHT**

**KOENIG'S SHELL EXTRACTOR.**



Every shooter should have one—carry it in a vest pocket. Fits any gauge shell. Koenig's Gun Catalogue, Free.

10 Cts. Postpaid.

**E. G. KOENIG, NEW JERSEY'S LARGEST GUN HOUSE**  
SOUTH BROAD ST., NEWARK, N. J.

**THE BRADLEY SHOT GUN SIGHT**



Wing Shooting is made easy and certain by using this gun sight. Scores at trap and in field greatly increased by its use. Right and left birds are bagged as easily as straight-away birds. **Price 50 Cents, Postpaid.**

**C. L. BRADLEY** Inventor, Clarksville, Tenn.

**SOME GOOD GUIDES.**

Following are names and addresses of guides who have been recommended to me, by men who have employed them; together with data as to the species of game and fish which these guides undertake to find for sportsmen.

If anyone who may employ one of these guides should find him incompetent or unsatisfactory, I will be grateful if he will report the fact to me.

**ALASKA.**

Edwin Edelmann, Kenai, Cook's Inlet, moose, bear, caribou, mountain sheep, ducks, grouse and trout.

**FLORIDA.**

Carson Bros., Frostproof, bear, deer, turkeys, quail, snipe.

C. H. Stokes, Mohawk, deer, alligators, turkey, quail, and snipe.

**IDAHO.**

John Ching, Kilgore, elk, bear, deer, antelope, mountain sheep, trout and grouse.

Chas. Petty's, Kilgore, ditto.

**MAINE.**

H. R. Horton, Flagstaff, deer, bear, moose, caribou, fox, grouse and trout.

W. C. Holt, Hanover, moose, caribou, deer, grouse and trout.

**MONTANA.**

A. R. Hague, Fridley, elk, deer, mountain sheep, bear, grouse and trout.

Chas. Marble, Chestnut, ditto.

**NEW YORK.**

Le Roy Still, Bayport, Long Island, ducks, quails, rabbits and grouse.

**WASHINGTON.**

Munro Wyckoff, Port Townsend, deer, bear and grouse,

**WYOMING.**

S. N. Leek, Jackson, elk, bear, deer, mountain sheep, antelope, grouse and trout.

James L. McLaughlin, Valley, elk, bear, deer, mountain sheep, antelope, grouse and trout.

**CANADA.**

Wm. S. Andrews, Lillooet, B. C., deer, bear, mountain sheep, goats, grouse and trout.

B. Norrad, Boiestown, N. B., moose, caribou, grouse and trout.

Carl Bersing, Newcastle, N. B., moose, caribou, deer, bear and grouse.

**NEWFOUNDLAND.**

John C. LeMoine, Birchy Cove, Bay of Islands, caribou salmon and trout.

**Big Game Hunters**

**FISHING AND OUTING PARTIES**

Before planning trips other than in New Brunswick, should apply to

**The New Brunswick Guides Association**

Fredericton, New Brunswick, Canada,

for information. The Association comprises the leading and most reliable guides in the Province.

**Hunting Map of New Brunswick**

Showing rivers, lakes, portage roads, carries, etc. Scale, 4½ miles to the inch, and folded to suit pocket. Mailed to any address on receipt of price, \$1.50. Checks accepted.

**FRANK WHITEHEAD,**

Fredericton, New Brunswick,

P. O. Box 303

Canada.

**George Stables**

Dealer in Fancy Groceries, etc. Sportsmen's Provisions a specialty.

Only the best quality goods kept in stock. Prices on application. **Public Square, Newcastle on the Miramichi, NEW BRUNSWICK.**

**For Exchange:** Side Companion Bicycle; far superior to tandem. Fine order; Frost gear cases; cost \$160; exchange for light hammerless gun.

**W. P. CORBETT,**

302 Park Place, Brooklyn, N. Y.

"The Busy Man's Train."

Appropriate in its Name,

Appropriate in its Route,

Appropriate in its Character -

**"The 20th Century Limited,"**

This is *The* century of all the ages. The New York Central's 20-hour train between New York and Chicago (the two great commercial centers of America) is *The* train of the century, and is appropriately named

**"The 20th Century Limited."**

A copy of "America's Summer Resorts," will be sent free, postpaid on receipt of a postage stamp by George H. Daniels, General Passenger Agent, New York Central & Hudson River Railroad, Grand Central Station, New York.

## Saratoga Springs, Lake George, Lake Champlain, the Adirondack Mountains, Au Sable Chasm, Sharon Springs

and many other cool, healthful Summer resorts in the elevated region of Northern New York, are described and illustrated in

### "A SUMMER PARADISE"

a handbook of the Northern Tour just issued by the DELAWARE & HUDSON RAILROAD, the Shortest, Quickest and Best line between New York and Montreal. Mailed to any address on receipt of 4 cents postage.

J. W. BURDICK, Gen. Pass. Agt.,  
Albany, N. Y.

**Do You Want a Drinking Cup Free-**  
Send me \$1 for a new subscription to RECREATION and I will send you a fine nickel-plated folding drinking cup. For 10 cents extra will send by registered mail. Mrs. Thomas H. Walker, 295 Merrimac Street, Manchester, N. H.

## BEST FISHING

AND

## FINE HUNTING

Earliest and latest Moosehead lake fishing is had here; also plenty of big game. House has been entirely refurnished; rooms have hot and cold water and baths. Grounds nicely graded, tennis court, croquet grounds and many fine woods roads laid out. Fishermen can avoid expense of guide by coming here, although we furnish guides, boats and canoes when desired. Several camps in our "string," all snug and attractive. Rates \$2.00 to \$2.50 per day. Descriptive Booklet sent free.

## At OUTLET HOUSE

(Formerly Moosehead House), MOOSEHEAD, ME. 11 miles from Greenville by C. P. R. R. or by Steamer.

**CHARLES. E. WILSON = Propr.**

New steamboat just bought to accommodate our guests.

10c. SEND FOR IT

## "Haunts of the Hunted"

Published by the

**Bangor & Argoostook R. R.**

*Entirely new Guide book for 1903, descriptive of Northern Maine. Book of 200 pages, finely illustrated by more than 100 half-tone cuts and with two full pages in colors. Write to Dept. H and enclose 10 cents in stamps.*

**GEO. M. HOUGHTON,**

Traffic Manager

BANGOR, ME.

## ADIRONDACKS

### Camp Mohawk and Cottages

Fourth Lake of the Fulton Chain. Patronized largely by families and parties of friends. Two handsome new cottages have been added this spring, which have very large rooms, fireplaces and baths. Write for booklet. Mention RECREATION.

MRS. H. H. LONGSTAFF, Old Forge, N. Y.

IN THE ADIRONDACKS

## Indian Lake House

Mountain View, N. Y.

C. C. Morgan, Prop.

ALL THE YEAR

All passenger trains on A. & St. L. R. R. will be met by boat and bus. Passengers conveyed directly to the house.

Rates. \$2 per Day.

Special Rates to Parties

Best DEER HUNTING and TROUT FISHING to be found in the Adirondacks

I would like to correspond with a few Sportsmen relative to unexplored regions. Beautiful undisturbed Nature, pure air, pure water, big game, big fish, trout and muskalonge. One day's paddle from railroad.

**E. C. TRIPP,**  
Atikokan, Ontario, Canada, Seine River Dist.

# ANOTHER GREAT OFFER TO AMATEUR PHOTOGRAPHERS

A 4 X 5 SERIES 1 KORONA CAMERA  
LISTED AT \$12, FOR 8 YEARLY SUBSCRIPTIONS TO *RECREATION*;

A 5 X 7 SERIES 1 KORONA CAMERA  
LISTED AT \$16, FOR 12 YEARLY SUBSCRIPTIONS;

A 4 X 5 SERIES 2 KORONA CAMERA  
LISTED AT \$18, FOR 14 YEARLY SUBSCRIPTIONS;

A 4 X 5 SERIES 3 KORONA CAMERA  
LISTED AT \$22, FOR 18 YEARLY SUBSCRIPTIONS;

A 4 X 5 SERIES 4 KORONA CAMERA  
LISTED AT \$25, FOR 20 YEARLY SUBSCRIPTIONS;

A 4 X 5 SERIES 5 KORONA CAMERA  
LISTED AT \$35, FOR 30 YEARLY SUBSCRIPTIONS.

*SAMPLE COPIES, FOR USE IN CANVASSING,  
FURNISHED FREE.*

A D D R E S S

## R E C R E A T I O N

23 WEST 24<sup>TH</sup> STREET, NEW YORK CITY



Price \$2.50 each

## There is **ECONOMY** and **PLEASURE**

in *Loading* and *Re-Loading* your own *Shot Gun Shells* if you have the proper implements. There is an entire line of

### **NEW TOOLS UP TO DATE**

for this purpose *Now Ready*. Full description and prices of all will be found in our new booklet entitled "*Hints on Loading and Reloading Shot Gun Shells*," which will be sent to any address upon application to

**IDEAL MANUF'G CO., 12 U St., New Haven, Conn., U. S. A.**

**THE PHIL. B. BEKEART CO., of San Francisco, Cal., Agents for Pacific Coast.**

When you write please mention Recreation.

## THE DAVENPORT Hammerless No. 2

With Full Length Matted Top Rib



OUR LATEST

Without a **PEER** for the  
Trap.

Send for latest edition of our catalogue — just out.

Mention  
Recreation

Our "**Brownie**" Rifle is in great demand amongst the "boys"—22 caliber only

**The W. H. Davenport Fire Arms Co., Norwich, Conn.**

**Free:** To anyone sending, through me, \$1 for yearly subscription to RECREATION, I will send free a No. 1 Sportsman's Medicine Case; for 2 subscriptions a Physician's Pocket Medicine Case; for 10 subscriptions 1,000 12-gauge primed paper shot shells. This offer is not open to old subscribers who formerly have sent in their subscriptions to the office of RECREATION, but to all others.

Walter Lussion, Ardmore, Pa.

MEXICAN OPAL AND SOMBRERO  
FREE WITH EACH SUBSCRIPTION TO RECREATION.

To anyone subscribing to RECREATION through me, I will send free a beautiful genuine Mexican Opal as large as a pea, together with a miniature Mexican Sombrero, made of silver and horsehair beautifully dyed. Arthur Thomson, Box 332, San Antonio, Texas.

# WANTED

Every owner of a shot gun to learn all about our handy little  
Target Trap.

*A Card Brings the Information*

Mention RECREATION.

**THE MITCHELL MFG. CO., London, Ohio**

# ITHACA GUNS

## CROSS BOLTED

THE DOUBLE THICK NITRO BREECH.

THE NARROW SKELETON RIB TAPERING GRACEFULLY TO THE MUZZLE.



**16 GRADES \$19.50 TO \$300**

**ITHACA GUN CO., ITHACA, NEW YORK**

# ITHACA GUNS

## Newhouse Traps

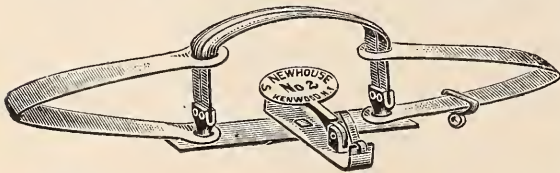

THE STANDARD FOR OVER FIFTY YEARS

Used by all professional hunters and trappers, who find that

**The Best Trap is the Cheapest**

Complete illustrated catalogue on application.

ONEIDA COMMUNITY, LTD., Kenwood, N. Y.



## "Collan-Oil"

preserves leather and renders shoes and harness positively

**WATERPROOF**

Used by the U. S. the Army and Navy, and National Guard.

Send 25c. for trial can.

AGENTS WANTED

Write for terms and circulars

J. R. BUCKELEW

Dept. A.

111 Chambers St., N. Y.

## THE BAKER

THE GUN THAT'S SAFE



SO DURABLE TOG  
IT LASTS A  
LIFETIME

If you want to be right up in the front rank of style and efficiency shoot one of our **Special Paragons** with *Whitworth* or *Krupp* fluid steel barrels. We have other patterns also that would please you. Our "Quarterly" tells about them and other matters that would interest you. We will send it to you *free a year* if you want it.

**BAKER GUN & FORGING CO., 42 Liberty Street, Batavia, N. Y.**

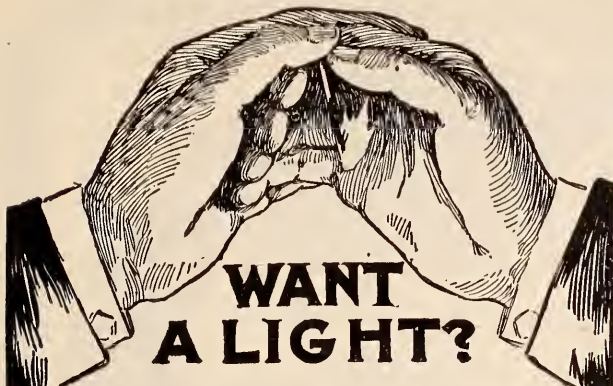

**WANT  
A LIGHT?**

Every sportsman knows the value of dry matches. They're always a comfort; sometimes they save lives.

**THE RECREATION  
WATERPROOF MATCHBOX**

is the *only* waterproof matchbox ever offered sportsmen which is worth pocket room.

It is substantially made from brass, heavily nickeled, and holds enough matches to keep a man in smokes and fires for several days.

**Price 50 cents.** For sale by dealers everywhere. or  
**Marble Safety Axe Co., Gladstone, Mich.**

- Marble's Safety Pocket Axes.
- Marble's Automatic Gaff Hook.
- Marble's Compass and Bracket.
- Marble's Ideal Hunting Knife.

Send for  
Catalogue A  
**FREE**

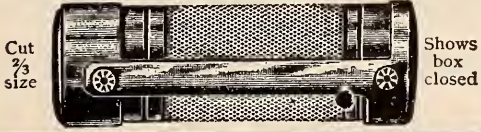

Cut  
2/3  
size

Shows  
box  
closed

PHOTO E. SCOTFORD-CHICAGO

**A Broken  
Hunting Knife.**

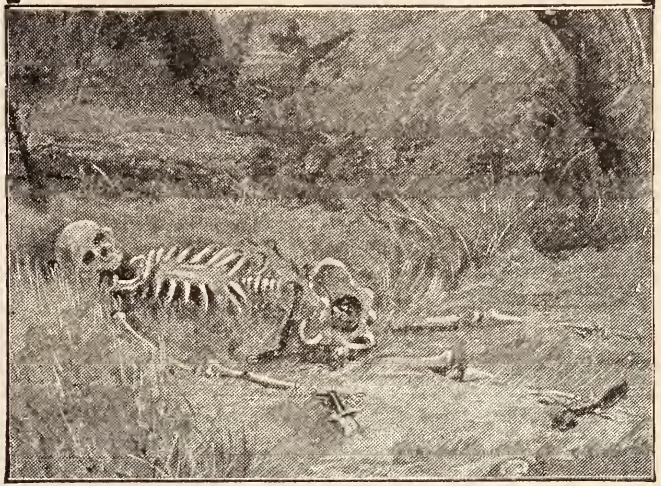

A few days ago the newspapers told the story of the discovery of the skeleton of a man—evidently a hunter—who perished in a hand to hand fight with a bear *because his hunting knife broke.*

**Marble's Safety Pocket Knife**

cannot break. It is hand forged from the best selected steel. Folds when not in use, yet locks perfectly rigid when open—not a toy, but a knife to stake a life on. Price \$4.00 from all dealers or direct from the manufacturers.

Send for catalogue A.

**MARBLE SAFETY AXE CO., GLADSTONE, MICH.**

**Practical Common Sense  
in 6 Sizes. CAMP STOVE**

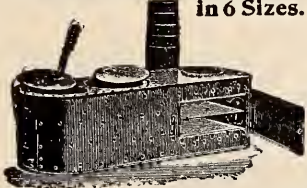

Either with or without oven. The lightest, strongest, most compact, practical stove made. Cast combination sheet steel top, smooth outside, heavy lining in fire box and around oven, holds its shape, telescopic pipe carried inside the stove. Burns larger wood and keeps fire longer than any other. Used by over 9,000 campers and only one stove returned.

For catalogue giving full particulars, mention RECREATION and address,  
**D. W. CREE, Manufacturer, Griggsville, Ill.**

**THE  
1902 Model**



**LEATHER-COVERED** Pneumatic Recoil Pad is now perfect. No pump, no valve, no recoil, no flinch, no headache, no bruised shoulders, no money if not satisfactory and returned at once. **PRICE \$2.**

**J. R. WINTERS  
Clinton, Mo.**

**THE PARKER  
AUTOMATIC  
EJECTOR**

The Latest attachment to  
**The "OLD  
RELIABLE"**



New York Salesroom, 32 WARREN ST. Send for Catalogue. MENTION RECREATION. **PARKER BROS., Meriden, Conn.**

H. &amp; R.

# "Bicycle Hammerless" Revolver

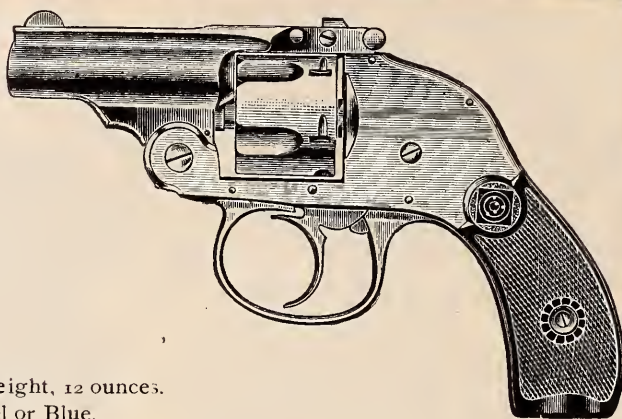

### Description

32 Caliber, 5 shot. 2 Inch Barrel. Weight, 12 ounces.  
C. F., S. & W. Cartridge. Finish, Nickel or Blue.

**IMPOSSIBLE TO CATCH** on the pocket and discharge accidentally. **ABSOLUTELY SAFE.** Although designed for cyclists, this revolver is equally adapted to all cases where a small, light weight, effective and handy pocket weapon is desired. It has small frame and automatic ejector. Sold direct where dealers will not supply.

## HARRINGTON & RICHARDSON ARMS CO.

Makers of H. & R. SINGLE GUNS

Catalog for Postal  
Dept. R.

**WORCESTER, MASS.**

# Charles Daly Rifle<sup>a</sup> and Shotgun<sup>d</sup>

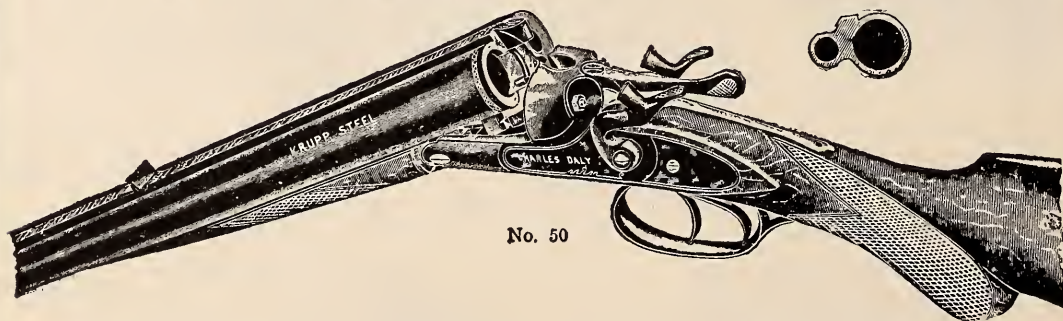

No. 50

Responding to an increased demand for a Combined Rifle and Shotgun of a finer quality than is usually offered, we have decided to place on the market a **Charles Daly Rifle and Shotgun.** This gun is made with the same care and of the same quality as all our Daly guns, and the sportsman buying one of them can feel that he has the best that money can buy of this particular kind of firearm. The gun has graceful lines and is beautifully balanced. It has top-snap action, rebounding bar locks, matted doll's head extension rib, Krupp's steel barrels, properly sighted for absolutely perfect rifle shooting and the shotgun is bored for field and game shooting.

No. 50—12 gauge shotgun barrel, 30/30 or 38/55 rifle barrel, 28 inches long, weight 7½ to 8 pounds. **PRICE, \$50.**

## SCHOVERLING, DALY & GALES

302-304 Broadway, New York



# "HOPKINS & ALLEN" Single Barrel Shot Guns

(Made for any powder and good for any shot.)

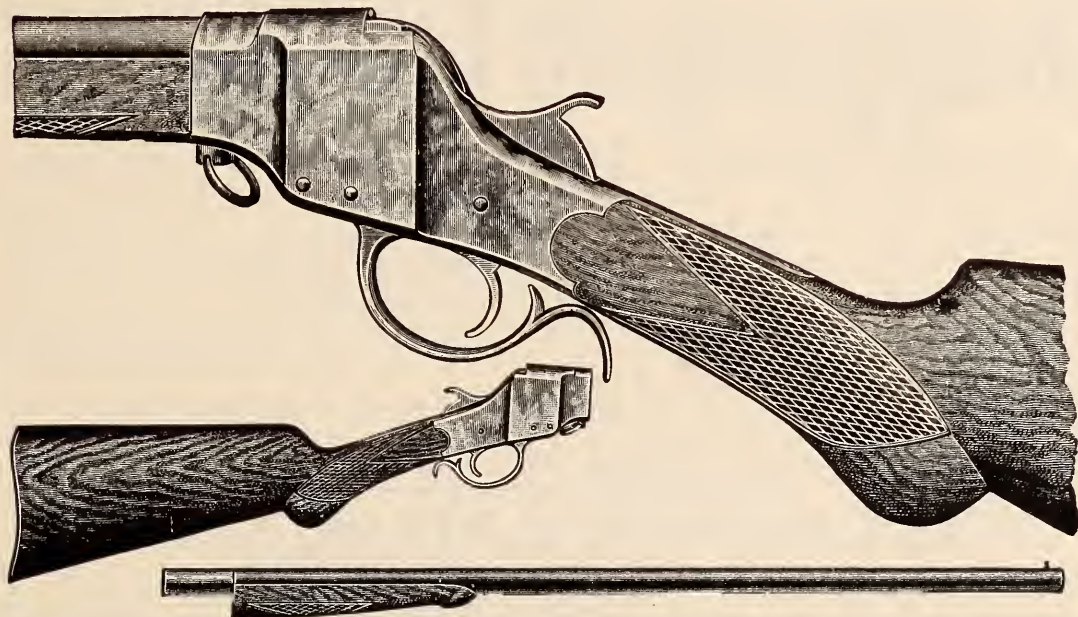

Our "Lever Action" has more friends than any single gun made, has stood the test of fifteen years' continued approval. Simple, durable and reliable, 12 and 16 gauge blued steel barrel..... **\$8.00**



Our new model top snap action, combining all up-to-date features of a modern gun, including patent compensating snap fore end. Automatic shell ejector, **Full Choke Bored.** 12, 16 and 20 gauge decarbonized steel barrel..... **\$9.00**  
 12 and 16 gauge Stubbs twist steel barrel..... **\$10.00**

*We will ship, all charges prepaid, on receipt of remittance with order, to any express office in the U. S. A.*

**The Hopkins & Allen Arms Co.,**  
**NORWICH, CONN., U. S. A.**

# FIRE SALE

500 Guns At Reduced Prices

GREAT

## Bargains in Fine Guns

By a fire in our Warerooms on June 9th a part of our stock of Fine Guns and Sportsmen's Goods was partially damaged by water, and we shall close them out at greatly reduced prices to make quick sale.

W. C. Scott & Sons, Premier and other grades—Greener, Langs, Parkers, Remington, Ithaca, and all the leading makes.

Also other articles in Sportsmen's Goods, Athletic Goods, Bicycles, Cutlery, etc.

Send two stamps for List of Guns, showing sizes, etc.

The Chance of the Year

### WILLIAM READ & SONS

107 Washington St., Boston, Mass.

ESTABLISHED 1826

I had a delightful trip down the Kissimmee last winter, thanks in no small degree to you. The Mullins galvanized steel canoe and Get There boat, used by a friend and me, were so good that I recommend them to anyone in search of light, dry boats which will stand hard usage. Anyone who contemplates a camping trip will be doing himself an injury if he should fail to correspond with Abercrombie & Fitch. We used one of their special waterproof tents, folding aluminum bakers, knockdown fry pans, and last but not least, one of their waterproof canvas buckets, which is one of the handiest things a camper ever got his

claws on. You can leave it filled with water a week, and it refuses to leak. At the mouth of the Hole in the Wall, on the Kissimmee river, we met 2 New York men, in the most beautiful canoe I ever saw. It was built by Rushton, another of RECREATION's patrons. I must also shout a few in praise of the Bristol steel rod. With the one you gave me I captured a catfish 33 inches long. I was fast to him nearly an hour, and in that time learned to love the little rod. I advise anyone seeking catfish to hie him to the Kissimmee.

C. O. Moseley, Lytle, Ga.



We make a specialty of Featherweights  
and Trap Guns with our new  
SINGLE TRIGGER

Send stamp  
for 1903 Catalogue  
Mention RECREATION

**D. M. LEFEVER SONS & CO.,**

Manufacturers of the "NEW LEFEVER"

Not connected with Lefever Arms Co.

**SYRACUSE, N. Y.**

Guaranteed  
Perfect

Our New  
Perfect  
Gun Cleaner  
By Mail,  
30 Cents

Guaranteed to Shoot ANY Nitro Powder and  
NOT GET LOOSE

Any  
 One of the **9**

**“SYRACUSE”**

Built for Business.

Whether Grade “OO”  
 listing at \$30.00  
 or  
 Grade “D”  
 listing at \$475.00.

A Masterpiece  
 by  
 Master Craftsmen

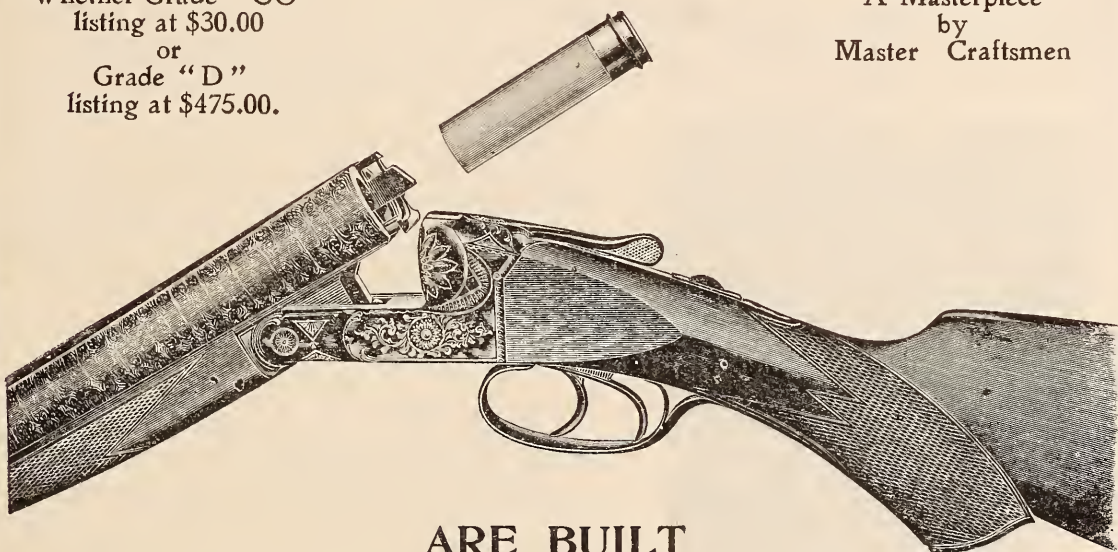

ARE BUILT

10 GAUGE BARRELS on a 10 GAUGE FRAME  
 12 GAUGE BARRELS on a 12 GAUGE FRAME  
 16 GAUGE BARRELS on a 16 GAUGE FRAME  
 20 GAUGE BARRELS on a 20 GAUGE FRAME

Dray Wheels and Sulky Body even though both are made well,  
 would prove a poor combination

SYRACUSE CATS

TELL

THE

STORY.

**SYRACUSE  
 ARMS CO.**

**SYRACUSE, N. Y.**

Mention RECREATION.



THE  
WORLD'S  
STANDARD



THEY'RE MADE TO MEASURE

# Putman Boots.

Go on like a glove *and* fit all over.

For a **Quarter of a Century** Putman Boots have been the Standard among Western Hunters, Prospectors, Ranchmen and Engineers (who demand the best) and we have learned through our personal contact with them **how** to make a perfect boot.

Putman Boots are in use in nearly every civilized country in the World. They are Genuine Hand Sewed, Water proof, Made to measure, Delivery charges prepaid, and cost no more than others. Send for Catalogue of over **30 different styles** of boots. Also **Indian Tanned Moosehide Moccasins**. We send with catalogue Order Blanks showing how to measure your foot.

We have in our files thousands of letters similar to the following.

**GENTLEMEN:**—Please send me another catalogue. We are all wearing Putman Boots and find them far superior to any other boot. I have ordered about 20 pairs for friends here during the past three years, and every pair has given perfect satisfaction, and I feel that I have done a man a favor when I have recommended your goods to him. Respectfully,

W. H. FLUKER, Gen. Mgr,  
(Columbia Mining Co.)  
Tatham, Ga.

**GENTLEMEN:**—I have just returned from a duck hunt in Colleton Co. this state, and though I tramped through the marshes for six days and a part of the nights, sinking in mud and water nearly to the tops of the shoes I got from you, my feet kept dry throughout the trip and the shoes were as soft at the wind-up as at the beginning. I can cheerfully recommend your shoes to all sportsmen. Yours respectfully,

C. F. DILL,  
Greenville, S. C.

**GENTLEMEN:**—Was fishing through the ice on the Flathead River this week standing for hours in wet snow and slush and tramping through the mountains, and I found the boots you built for me in December to be thoroughly water and snow proof, and quite warm. Yours truly,

L. R. FOGLE, Great falls, Mont.

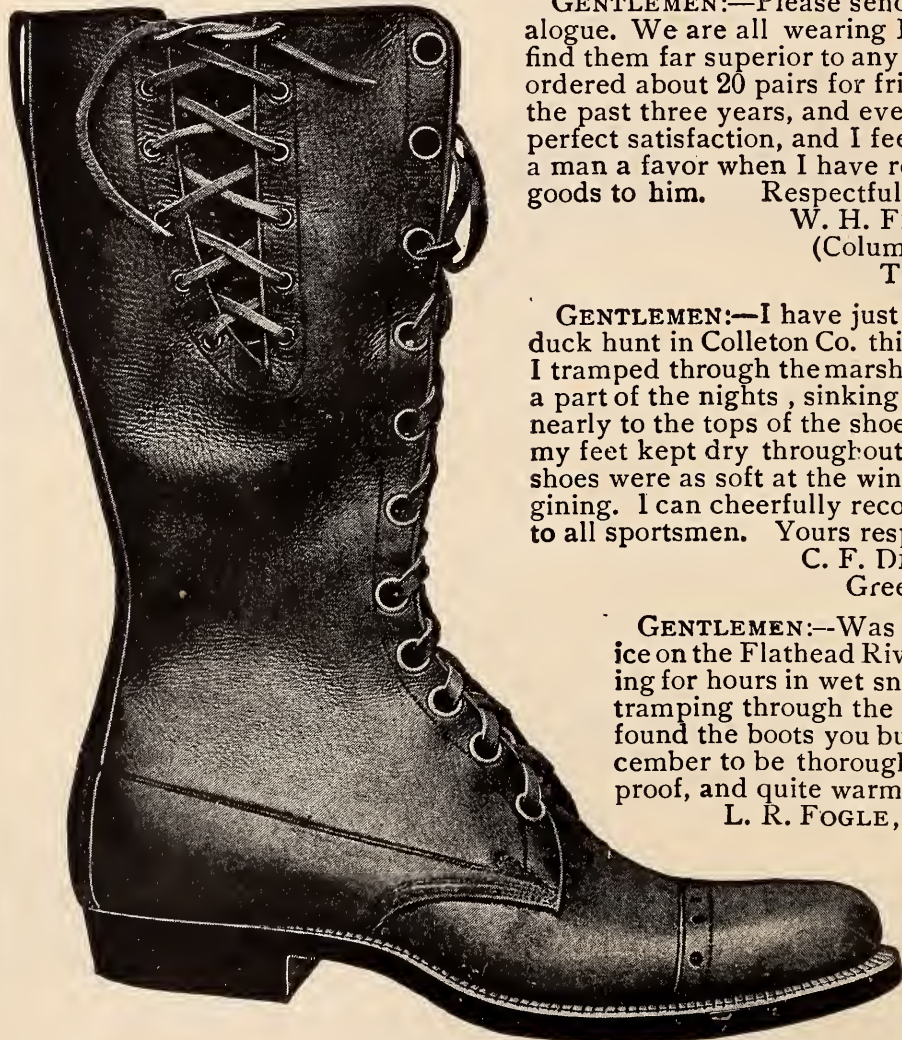

Illustration shows  
No. 900, 14 inch  
Boot, made to measure  
and delivered  
in U. S. for

**\$7.50.**

**H. J. PUTMAN & CO.,**

36 HENNEPIN  
AVE.

**Minneapolis, Minn.**

# Libby's

## Picnic Luncheons



### Summer Time Satisfaction

When cooking is a drudgery and the appetite craves cool, refreshing dishes—dainty, toothsome foods—at home or for picnic outings—you will find

### Libby's (Natural Flavor) Food Products

the most delicious meats to serve on any occasion. For picnic luncheons Libby's Melrose Pate, Veal Loaf, Peerless Dried Beef, Ox Tongue, Chicken and Luncheon Loaf stand supreme.

The booklet, "How to Make Good Things to Eat" sent free. Send five 2c stamps for Libby's Big Atlas of the World.

**Libby, McNeill & Libby**  
Chicago



# ON TOP

## SAVAGE RIFLES

THE new high power 25-35, 32-40 and 38-55 calibers have recently been added to the famous 303 or 30-30 Model 1899 Repeater. If you hunt large or small game these sizes will interest you.

CATALOG G ON REQUEST.

**Savage Arms Company**  
Utica, N. Y., U. S. A.

BAKER & HAMILTON, *Pacific Coast*  
Agents, San Francisco and Sacramento, Cal.

## KITCHEN MONEY

**\$7,500.00 Donated**  
**To Be Divided Among**  
**Family Cooks**

Great numbers of ladies have requested an extension of time on this contest. It has been granted; full particulars by mail. See below.

The sum of \$7,500.00 will be distributed between now and fall among family cooks, in 735 prizes, ranging from \$200.00 to \$5.00.

This is done to stimulate better cooking in the family kitchen. The contest is open to paid cooks (drop the name "hired girl," call them cooks if they deserve it) or to the mistress of the household if she does the cooking. The rules for contest are plain and simple. Each of the 735 winners of money prizes will also receive an engraved certificate of merit or diploma as a cook. The diplomas bear the big gilt seal and signature of the most famous food company in the world, the Postum Cereal Co., Ltd., of Battle Creek, Mich., the well-known makers of Postum Coffee and Grape-Nuts. Write them and address Cookery Department, No. 119, for full particulars.

Great sums of money devoted to such enterprises always result in putting humanity further along on the road to civilization, health, comfort and happiness.



## Club Cocktails

Famous the world over for purity. They never vary. The secret of their perfect blend is that they are kept six months before being drawn off and bottled. Be sure you have them in your camp, on the yacht, and on your outing trips wherever you go. They are ready and require no mixing. Simply pour over cracked ice.

For Sale by all Fancy Grocers and Dealers

**G. F. HEUBLEIN & BRO.**  
29 BROADWAY, N. Y. HARTFORD, CONN.

# VOSE

## PIANOS

have been established over 50 YEARS. By our system of payments every family in moderate circumstances can own a VOSE piano. We take old instruments in exchange and deliver the new piano in your home free of expense. Write for catalogue D and explanations.

VOSE & SONS PIANO CO., 160 Boylston St., Boston, Mass.

AUG 27 1903

VOLUME XIX.  
NUMBER 3

SEPTEMBER, 1903

\$1.00 A YEAR  
10c. A COPY

# RECREATION

SOME FEATHERED FOLK; BY MARTHA M. WILLIAMS, with numerous drawings by J. O. NUAGENT and E. J. SAWYER

OFFICIAL ORGAN OF THE LEAGUE OF AMERICAN SPORTSMEN



AMATEUR PHOTO BY W. A. MASON.

A FOREST FREAK IN STORY COUNTY, IOWA.

PUBLISHED BY G. O. SHIELDS (COQUINA)  
23 WEST 24TH ST., NEW YORK

## HUNTING ELK IN A WINDFALL;

By E. B. SHANKS, with full page drawings by CARL RUNGIUS and H. D. NICHOLS.

There comes a time in the life of every individual when the use of a stimulant is not only advisable but necessary

As you approach the calm and mellow evening of your life you have doubtless learned the value of a pure and wholesome cereal stimulant to sweeten solitude and keep off the blues.

When choosing a stimulant for medicinal use or purpose of good cheer endeavor to obtain a mild soothing amiable fluid that does not inflame or excite, but gently stirs and quickens the life current.

REGISTERED AND SPECIAL BRANDS

Per Gal.	<b>Holiday Pure Rye - 4.00</b> (Eleven Years Old)	Per Gal.	<b>Old Gold Bourbon - \$4.00</b> (Eleven Years Old)
<b>Hermitage Rock &amp; Rye 4.00</b> <i>Superior</i>	Five pounds of rock candy crystals to each gallon of seven year old Hermitage Rye whiskey, is used in the preparation of our Celebrated Rock and Rye.	<b>Jewel Port - 4.00</b>	From Silva & Cosens, Oporto. A choice product of the grape.
<b>Bon Ton Cocktails - 4.00</b>	Martini, Manhattan, Vermouth, Whiskey, Tom Gin and Holland Gin. Carefully prepared from the choicest materials, perfectly blended.	<b>Rainbow Brandy V.O. 4.00</b>	The product of one of the best American Vineyards, with all the medicinal qualities of French Brandy.
<b>Ruthven Sherry - 4.00</b>	From Duff, Gordon & Co. Warranted twenty years in the wood before bottling. Rich and fruity.	<b>Jupiter Gin - 4.00</b>	From the Swan Distillery, Schiedam, Holland, where Good Gin comes from. Tastes differ. Many people appreciate Good Gin. Jupiter is the best the world affords.
		<b>Medford Old Rum - 4.00</b>	From Daniel Lawrence & Sons, Medford, Mass.

On receipt of your order with \$6.00, we will ship 6 full quarts assorted to suit, transportation charges prepaid, to any railroad point in the United States where the charges for transportation do not exceed \$2.00. You cannot afford to let this chance go by. You never before had as good an offer.

If you accept our offer you will surely receive the **BEST** and the **MOST** for your money that ever came to you from any similar proposition.

Remit cash in registered letter or by express company or P. O. money order.

*References*; Any bank in Boston. Any mercantile agency or any distiller of importance in the United States.

**W. H. JONES & CO.,** Hanover & Blackstone Sts.,  
BOSTON, MASS.

ESTABLISHED 1851



# RECREATION

Copyright, December, 1902, by G. O. Shields

A Monthly Magazine Devoted to Everything the Name Implies

\$1.00 A YEAR.  
10 CENTS A COPY.

G. O. SHIELDS (COQUINA),  
Editor and Manager.

23 WEST 24TH STREET,  
NEW YORK

## CONTENTS OF THIS NUMBER

PAGE

He Was Uttering His Weird Call in Tones as Inspiring and as Musical as the Notes of a Flute.....	FRONTISPIECE
Hunting Elk in a Windfall. Illustrated.....	E. B. SHANKS 167
Some Feathered Folk. Illustrated.....	MARTHA M. WILLIAMS 171
A Deer Hunt in Mexico.....	J. K. EICHHORN 175
Rafting on the St. Joe. Illustrated.....	GEO. H. ROOT 177
Catching a Catfish. Illustrated.....	F. D. GREENE 181
Bob White. Poem.....	IRA SWEET 182
Quail Shooting in Kentucky.....	A. S. ATKINSON 183
A Leaf from the Log of the Rosamond. Illustrated.....	CHAS. VAN BRUNT, JR. 185
Among the Sandhills.....	JOHN MCNEIL 187
Hadn't Lost Any Bear.....	BOYD C. PACKER 191
Jock o' the Gun. Poem.....	DOROTHY H. BARRON 192
A Florida Kid on a Camp Hunt. XII.....	CHARLEY APOPKA 193
Our Trophies.....	G. A. MACK 195
From the Game Fields.....	197
Fish and Fishing.....	206
Guns and Ammunition.....	211
Natural History.....	217
The League of American Sportsmen.....	223
Forestry.....	226
Pure and Impure Foods.....	229
Book Notices.....	231
Publisher's Notes.....	233
Editor's Corner.....	234
Amateur Photography.....	238

Entered as Second-Class Matter at New York Post-Office, Oct, 17, 1894.

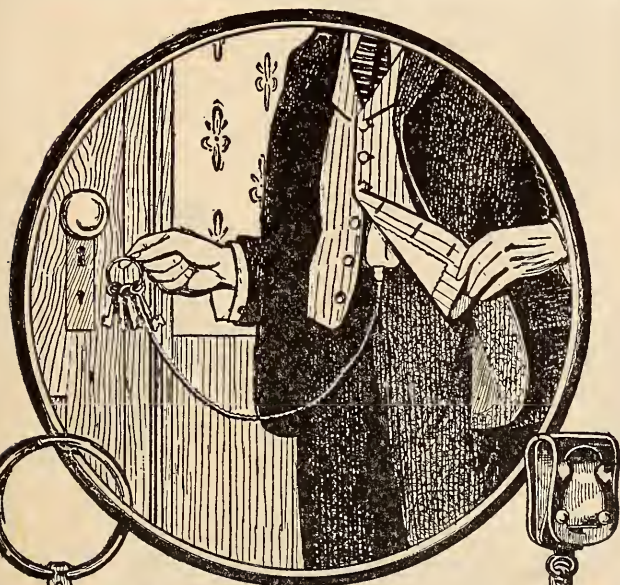

YOU CAN'T LOSE 'EM

WITH

WASHBURNE'S PATENT IMPROVED FASTENER and KEY CHAIN

Your keys are always with you. You cannot lay them down or leave them anywhere but in your pocket. At your dealers or sent on receipt of price--Key Rings and Chain, 25c.; Cuff Holders, 20c. a pair; Scarf Holders, 10c. Send for illustrated catalog.

AMERICAN RING CO., Dept. 44, Waterbury, Conn.

## Skin Diseases

Eczema, Salt Rheum, Pimples, Ringworm, Itch, Ivy Poison, Acne or other skin troubles, can be promptly cured by

# Hydrozone

Hydrozone is endorsed by leading physicians. It is absolutely harmless, yet most powerful healing agent, that cures by destroying the parasites which cause these diseases.

**Cures sunburn** in 24 hours. In cases of Prickly Heat and Hives it will stop itching at once, also will relieve mosquito bites instantly. Take no substitute and see that every bottle bears my signature.

Trial Size, 25 Cents.

At Druggists or by mail, from

*Prof. Charles Marchand*

F-59 Prince St., New York.

FREE {Booklet on the rational treatment of diseases sent free.

**"NOTHING SO RARE AS RESTING ON AIR."**



TAKING MINE EASE.

The only article in your outing outfit that you can use during the whole year is a

# Pneumatic Mattress OR CUSHION

## THE EVER PRESENT ROOT

in the bed of boughs is a thing of the past if you use a Pneumatic Mattress. A mattress for home use that you can deflate, pack in your grip and take with you into camp.

## SPRUCE BOUGHS

may make a fine bed. But the genuine Sportsman prefers a Pneumatic Mattress because he knows he can do three times the tramping the day following a night's good sleep.

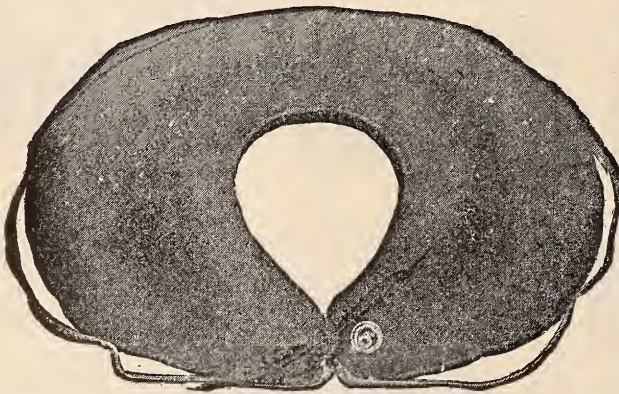

PRICE \$2.00

Carry it in your Pocket, it weighs just One Pound.

## Swimming Collar.

Worn around the neck, leaving the arms free for action. Will support a full-grown man. Just the thing when learning to swim.

Price, Small Size, \$1.50 Large Size, \$2.00

## Sportsman's Cushion.

A Yoke to save your shoulders

A Swimming Collar for those who can't swim.

A Life Preserver in case of accident.

A Cushion while waiting for Moose.

A Cushion or Head Rest while waiting for Duck.

A Protection for your shoulder if the gun is heavy.

A Cushion for CAMP, BOAT, OFFICE or HOME.

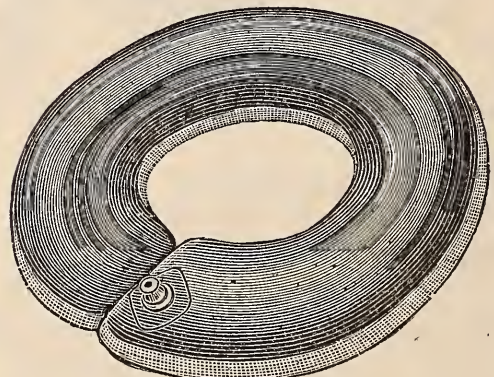

Swimming Collar.

**Pneumatic Mattress & Cushion Company,**  
2 R South Street, New York City.

# Abercrombie & Fitch

World's  
Headquarters  
for  
Fishing Tackle



## A 3 Cent Bait

in postage stamps will bring the biggest catch an angler, camper or sportsman can land—Abercrombie and Fitch's catalogue R, 160 pages, cuts and prices.

We guarantee to furnish a more satisfactory fisherman's outfit than can be obtained elsewhere.

**Complete outfits for explorers, campers and prospectors. Camp outfits from the most modest and practical to the most complete and luxurious.**

Compare our prices on tents, clothing, cooking outfits, folding buckets, camp packs, cots, chairs, food bags, folding shelves, guns, boots, moccasins, sleeping bags, pack saddles, stoves, pneumatic beds, cushions, duffle bags, pack harness, folding bakers, folding lanterns, rolling tables, fishing tackle, shoes, covers, &c.

314-316 BROADWAY, NEW YORK CITY

# Decorate Your Den

With a set of the most beautiful  
**Hunting and Fishing Pictures**  
 ever made.

---



---

**15 Plates. Size for Framing, 18 x 24 inches**

---



---

SUBJECTS:

**ELK HUNTING**      **SALMON FISHING** }  
**MOOSE HUNTING**   **TROUT FISHING** } HY. SANDHAM

**MALLARD SHOOTING** — **BLACK BASS FISHING** — C. E. DENTON

**TARPON FISHING** — **BLUE FISHING** — FRED S. COZZENS

**ANTELOPE HUNTING** — **GOOSE SHOOTING** — FRED REMINGTON

**GROUSE SHOOTING** — **WILD TURKEY HUNTING** — R. F. ZOGBAUM

**MUSKALONGE FISHING** — F. H. TAYLOR

**DEER HUNTING** — A. B. FROST

**ROCKY MOUNTAIN SHEEP HUNTING** — E. KNOBEL

These 15 plates are lithographed in true colors of nature and altogether make one of the finest series of pictures of outdoor sports ever published.

**ORIGINALLY ISSUED AT \$50 A SET**

I have bought the last of them and can furnish a complete set for 15 yearly subscriptions to RECREATION,

**Or will Sell at \$10 a Set**

I also have enlargements of the following photographs:

**ROCKY MOUNTAIN GOATS**

Published on pages 90, 91, 92, and 93 of the February issue of RECREATION,  
 \$5 a set.

**WOOD DUCK SHOOTING**

Published on page 95 of the February issue of RECREATION, \$1.50 each.

---



---

**Address: RECREATION, 23 West 24th Street, New York City**

# Canadian Pacific Ry.

## THE MOOSE HUNT.

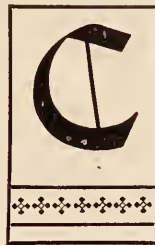

Stands for canoe,  
Which all must agree  
Floats rather too deeply  
To stand any sea.



Just means the packs,  
In which we have stored  
All dunnage that's needed  
For sport, bed or board.



Was the rover,  
Full sixteen hands tall,  
Whose antlers are gracing  
Our snug, study's wall.

*For further particulars apply to*

**ROBERT KERR, Passenger Traffic Manager, MONTREAL.**

Established 1840

**GEO. B. CARPENTER & CO.**  
MAKERS OF HIGH GRADE  
**TENTS, SAILS  
CAMP FURNITURE**

Folding Cots  
Tables and Chairs

Oars, Paddles  
Marine Hardware

Copyright 1899  
Geo. B. Carpenter & Co.

**The Largest and Most  
Complete Stock in the U. S.**

Send 4c. in stamps for Tent and Camp Catalogue, or  
6c. in stamps for Marine Hardware Catalogue.

200, 202, 204, 206, 208 S. Water St  
**CHICAGO, ILL.**

**SAILING. CAMPING. PROSPECTING. FISHING. HUNTING.**

# No Picture

can show you the good qualities of the **KENWOOD SLEEPING BAG**. You must see a complete combination bag to understand how perfectly it is adapted to the use of every man who sleeps out of doors or in a tent, under all conditions of climate and weather.

If your dealer does not have the **KENWOOD SLEEPING BAG**, write us for samples, prices and full information, then decide which quality you want and order it on approval. If it does not suit you in every way return it. We pay charges both ways. Don't buy any other sleeping bag or blankets before you have seen the Kenwood.

**THE KENWOOD MILLS**  
ALBANY, N. Y.



TYPICAL SCENE - MUSKOKA LAKES

THE "ROYAL MUSKOKA" HOTEL, MUSKOKA LAKES, CANADA.

Is elegantly furnished, fine cuisine, magnificent surroundings, 1000 feet above sea level.

Most charming summer resort region in America. Perfect immunity from Hay Fever assured.

For full particulars, Illustrated descriptive literature, rates, maps, and all information, apply to

G. T. BELL, Gen'l Pass'r and Tkt. Agent, GRAND TRUNK RAILWAY SYSTEM, MONTREAL, QUE.

OR TO

MUSKOKA NAVIGATION CO., LTD., TORONTO, CANADA.

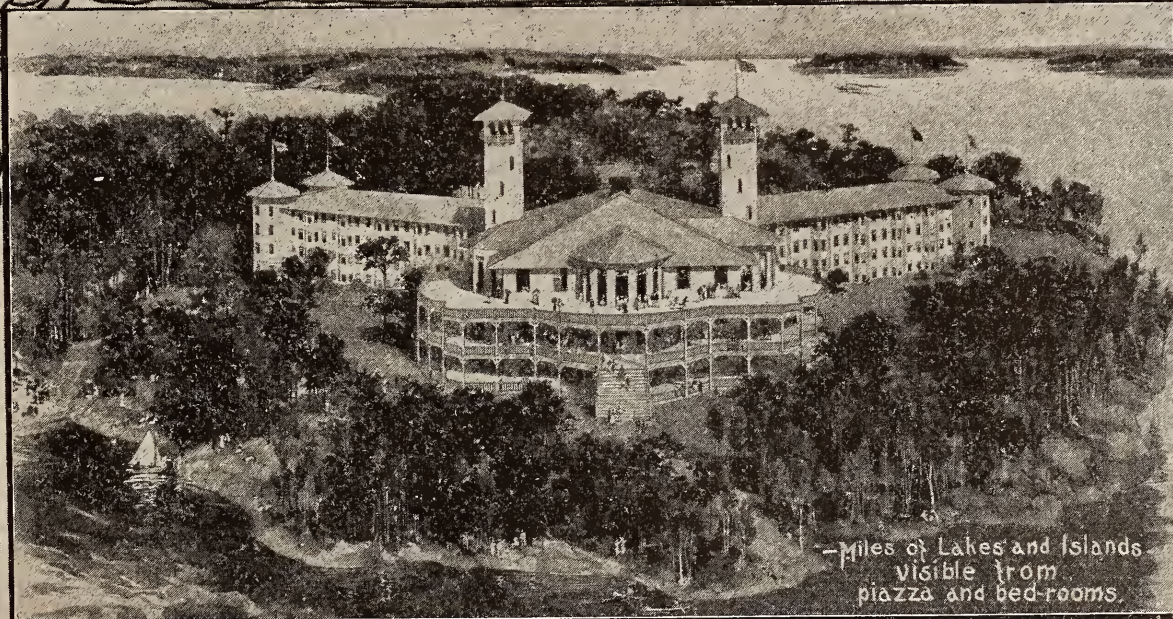

- Miles of Lakes and Islands visible from piazza and bed-rooms.

ROYAL MUSKOKA HOTEL

# SPRATT'S PATENT Cat Food

ALL breeders of high-class or exhibition cats have come to the conclusion from practical experience that an excessive meat diet, raw or cooked, is injurious to cats that are kept in confinement. It is also bad for the coat and it is difficult with unsystematic feeding to keep the animal in exhibition form.

**Spratt's Patent** has revolutionized the old method of Feeding Cats and prepared an easily digestible cooked food, composed of the different meals, flour, vegetables, etc., and containing only the necessary quantity of meat, together with other ingredients calculated to keep the cat in good health and exhibition form.

It has been used for many years at the National Cat Shows held in the English Crystal Palace; also at the American National Cat Show in Madison Square Garden and at most large exhibitions, besides which it is in constant use at the leading catteries. The increasing demand for it is the best proof of its virtues and value.

PRICE:—\$4.00 per 50 lbs.; \$2.25 per 25 lbs.; \$1.00 per 10 lbs.; Carton, 25c. Sample box, 5c. Postage (6c. extra.)

Write for our Catalogue, "Dog Culture," (with a chapter on Cats) and practical chapters on the feeding, kenneling and management of dogs, post free.

## SPRATT'S PATENT (AM.) Ltd.

450 Market St., Newark, N. J.

714 S. Fourth St., St. Louis, Mo.

1324 Valencia St., San Francisco, Cal.

Manufacturers of all kinds of Dog Foods and Medicines

"The groves were God's first temples."

## SEPTEMBER IN THE ADIRONDAKS

No finer place in September can be found than the Adirondacks. The air is cool and bracing, the fishing fine, the scenery beautiful, and they can be reached in a night from Boston, New York or Niagara Falls. All parts of the Adirondacks are reached by the

### NEW YORK CENTRAL LINES

A copy of No. 20 of the "Four-Track Series," "The Adirondacks and How to Reach Them," will be sent free on receipt of a 2-cent stamp by George H. Daniels, General Passenger Agent, New York Central R. R., Grand Central Station, New York.

# TALES OF ADVENTURE.

## Rare Hunting and Fishing Stories.

I have a few sets of Volume 3 of RECREATION, July to December, inclusive, 1895. These are handsomely bound in cloth, with leather backs and corners.

Here are the titles of a few of the choice stories in the book.

- Woodcock on the Islands.**  
Illustrated. F. W. G. Johnson
- The Gordon Setter.**  
Illustrated. Dr. J. Whitaker
- Salmon Fishing in Labrador.**  
Illustrated. Col. Charles E. Fuller
- Coursing with the Greyhound**  
Illustrated. L. F. Bartels
- A Bald-Faced Grizzly in Camp.**  
Illustrated. M. W. Miner
- Where Leaps the Ouananiche.**  
(Poem.) Dr. E. L. Tiffany
- Fly Fishing . . . . .** Dr. M. G. Ellzey
- A Half Hour With the Quail.**  
Dr. E. P. Kremer (Juvenis)
- A Deer Drive with Spokane Indians.**  
Illustrated. Lieut. W. R. Abercrombie
- An Indian Horse Race.**  
Maj. F. M. Bernard
- The Old Kentucky Rifle.** (Poem.)  
Illustrated. Capt. J. W. Crawford
- A Mystery of the Tetons.**  
Illustrated. Ed. H. Trafton
- Pheasant Shooting.**  
Illustrated. Thomas G. Farrell
- Sitting Bull's Last Medicine.**  
Illustrated. Margaret Gray Brooks
- Crossing the Plains 30 Years Ago.**  
Illustrated. Gen. John Gibbon, U. S. A.
- A Mountain Lion Hunt by Night.**  
Illustrated. Robert Meade Smith, M.D.
- Trouting on Clark's Fork.**  
Illustrated. Gen. F. W. Benteen, U. S. A.
- Ducking off Machipongo.**  
Illustrated. W. J. Bogert
- A Youthful Guide and a Prize Bighorn.**  
Illustrated. Hon. I. N. Hibbs
- A Wild Goose Chase.**  
Illustrated. A. E. McKenzie
- A Tempestuous Cruise.**  
Illustrated. Commodore Chas. Pryer
- Hans the Wolf Hunter.**  
(Poem.) Illustrated. S. N. McAdoo
- How Some Women Went Shooting.**  
Illustrated. Julia C. Welles

These books will be sold at \$2.00 each, and when the present supply is exhausted there will never be any more. If you want a copy remit at once. Address,

RECREATION, 23 W. 24th St.,  
New York City



IF  
you want

## TO GET VIM

and elasticity in a pup  
troubled with worms, **get rid  
of the worms.** If you want lus-  
trous eyes and jolly companionship  
in a dog who has worms, **kill the worms.**

There is in every business some standard of  
excellence that all strive to gain all claim they  
have it yet still keep striving. We believe we have  
in "SURE SHOT" the standard vermifuge because it is  
compounded by a scientific, practical and experienced man  
who has owned and studied the well dog and the sick dog in home  
and in field pretty much all his life. At any rate we do not try to  
better it for we know it can't be improved upon, and the formula is our  
sole property.

You've known all along what worms will do to a dog as a puppy or adult.  
Now you know the best remedy for ridding a dog of worms.

## SERGEANT'S "SURE SHOT"

is a remedy with a string of successful years behind it, because it is  
thoroughly safe and reliable. No harm can follow its use even if worms  
are not the trouble, and it will give puppies a strong, healthy constitu-  
tion that will fight victoriously the ravages of disease later in life. No  
first-class kennel manager or private owner ever thought of being with-  
out it, once he used it.

Lock Box 103, HOLLY SPRINGS, MISS.

"I consider "SURE SHOT" the best medicine I have ever used for worms in  
puppies, and the least trouble to administer. Mrs. ROBERT HASTINGS.

SERGEANTS "SURE SHOT" per bottle 50c. Sold by Druggists or  
Sporting Goods Dealers everywhere or mailed (prepaid) from

**POLK MILLER DRUG CO.,  
RICHMOND, VIRGINIA, BOX 217.**

There isn't anywhere a dog lover or owner who wouldn't  
like to have our 48 page Treatise on  
Dogs. We will send it and a Ped-  
igree Blank to any address for  
3 cents in stamps, which  
go to pay the postage.

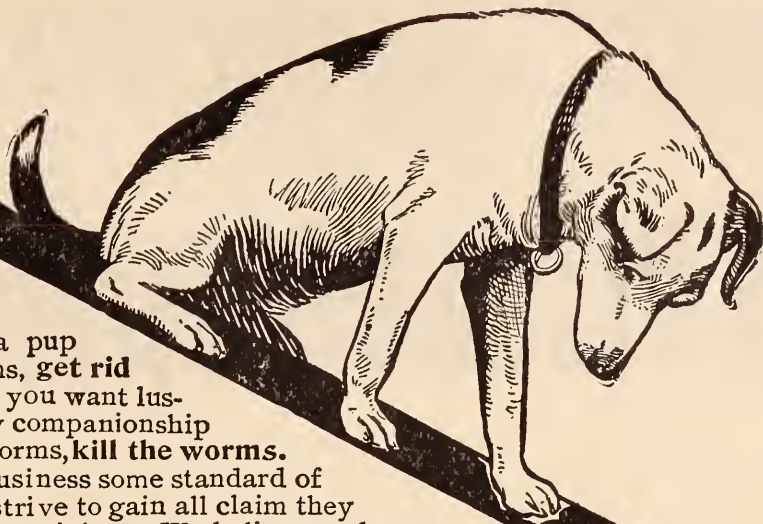

---

STILL ANOTHER GREAT OFFER

# A Grade OO Syracuse Gun

*Listed at \$30.*

FOR

*25 Yearly Subscriptions*

TO

## Recreation

If you Want one of the Guns get a move on you

Sample copies for use in canvassing  
furnished on application

---

---

**RECREATION, 23 W. 24th Street, New York**



THE  
WORLD'S  
STANDARD



THEY'RE MADE TO MEASURE

# Putman Boots.

Go on like a glove *and* fit all over.

For a **Quarter of a Century** Putman Boots have been the Standard among Western Hunters, Prospectors, Ranchmen and Engineers (who demand the best) and we have learned through our personal contact with them **how** to make a perfect boot.

Putman Boots are in use in nearly every civilized country in the World. They are Genuine Hand Sewed, Water proof, Made to measure, Delivery charges prepaid, and cost no more than others. Send for Catalogue of over **30 different styles** of boots. Also **Indian Tanned Moosehide Moccasins**. We send with catalogue Order Blanks showing how to measure your foot.

We have in our files thousands of letters similar to the following.

**GENTLEMEN:**—Please send me another catalogue. We are all wearing Putman Boots and find them far superior to any other boot. I have ordered about 20 pairs for friends here during the past three years, and every pair has given perfect satisfaction, and I feel that I have done a man a favor when I have recommended your goods to him.

Respectfully,

W. H. FLUKER, Gen. Mgr,  
(Columbia Mining Co.)  
Tatham, Ga.

**GENTLEMEN:**—I have just returned from a duck hunt in Colleton Co. this state, and though I tramped through the marshes for six days and a part of the nights, sinking in mud and water nearly to the tops of the shoes I got from you, my feet kept dry throughout the trip and the shoes were as soft at the wind-up as at the beginning. I can cheerfully recommend your shoes to all sportsmen.

Yours respectfully,

C. F. DILL,  
Greenville, S. C.

**GENTLEMEN:**—Was fishing through the ice on the Flathead River this week standing for hours in wet snow and slush and tramping through the mountains, and I found the boots you built for me in December to be thoroughly water and snow proof, and quite warm.

Yours truly,  
L. R. FOGLE, Great falls, Mont.

Illustration shows  
No. 900, 14 inch  
Boot, made to measure  
and delivered  
in U. S. for

**\$7.50.**

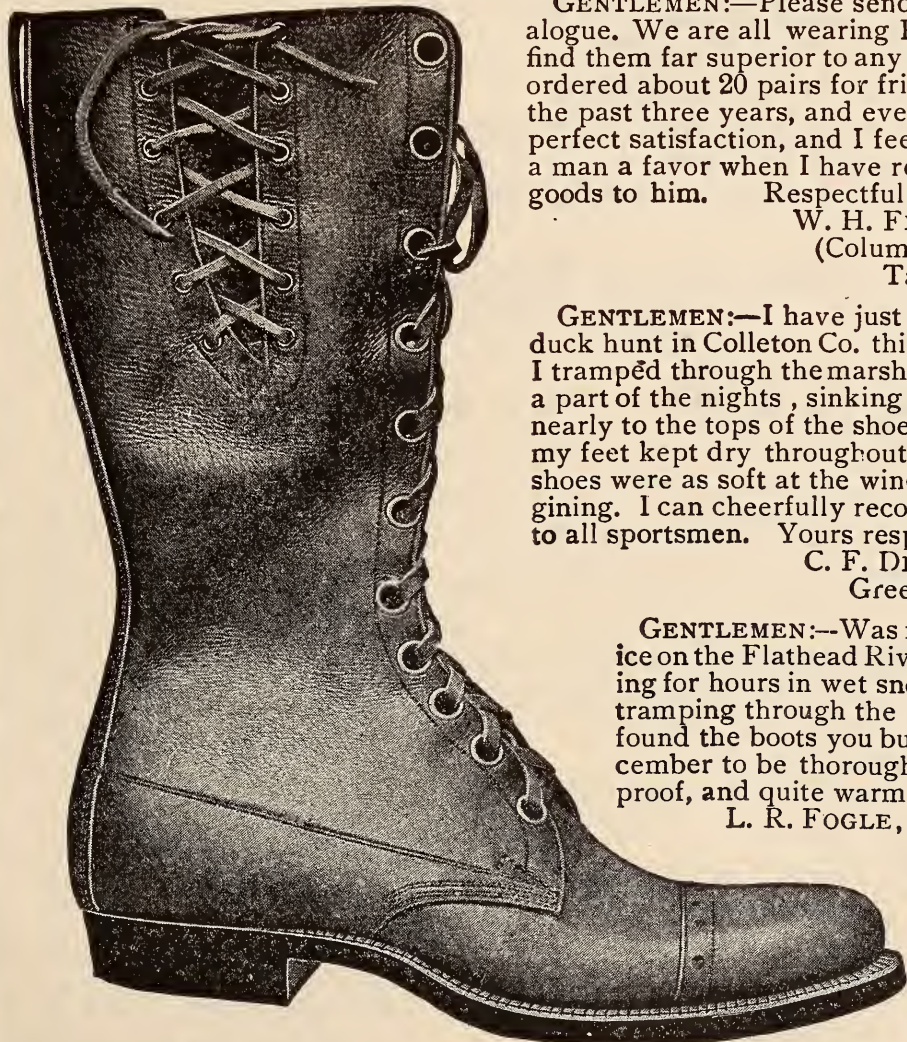

**H. J. PUTMAN & CO.,**

36 HENNEPIN  
AVE.

**Minneapolis. Minn.**

# ANOTHER GREAT OFFER TO AMATEUR PHOTOGRAPHERS

A 4 X 5 SERIES 1 KORONA CAMERA  
LISTED AT \$12, FOR 8 YEARLY SUBSCRIPTIONS TO *RECREATION*;

A 5 X 7 SERIES 1 KORONA CAMERA  
LISTED AT \$16, FOR 12 YEARLY SUBSCRIPTIONS;

A 4 X 5 SERIES 2 KORONA CAMERA  
LISTED AT \$18, FOR 14 YEARLY SUBSCRIPTIONS;

A 4 X 5 SERIES 3 KORONA CAMERA  
LISTED AT \$22, FOR 18 YEARLY SUBSCRIPTIONS;

A 4 X 5 SERIES 4 KORONA CAMERA  
LISTED AT \$25, FOR 20 YEARLY SUBSCRIPTIONS;

A 4 X 5 SERIES 5 KORONA CAMERA  
LISTED AT \$35, FOR 30 YEARLY SUBSCRIPTIONS.

*SAMPLE COPIES, FOR USE IN CANVASSING,  
FURNISHED FREE.*

A D D R E S S

## R E C R E A T I O N

23 WEST 24TH STREET, NEW YORK CITY

# Ever been there Friend?



If so you know that you can't get through without an axe.

## Marble's Safety Pocket Axe

is the way out of difficulties.

Large enough to fell a tree, build a camp or quarter a deer. Small enough to go in the pocket. Send for Catalogue.

SOLD BY DEALERS OR DIRECT FROM THE  
**MARBLE SAFETY AXE CO.,**  
GLADSTONE, MICH.

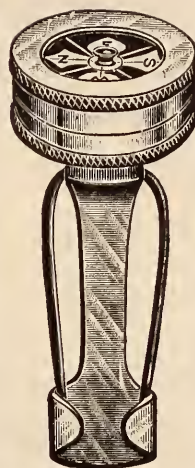
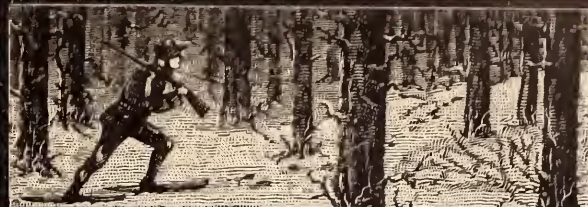

Cut  $\frac{1}{2}$  actual Size.

**W**ISE men don't go hunting, or fishing, or camping, or yachting, or prospecting, without a compass.

## MARBLE'S HANDY COMPASS

attaches to outside of coat or vest. Always in sight. Cannot be lost, cannot be demagnetized. Thoroughly reliable. Price with revolving card and jeweled needle, \$1.50. With plain jeweled needle, \$1.25.

Send for Catalogue. A

FOR SALE BY DEALERS, OR  
**MARBLE SAFETY AXE CO.**  
GLADSTONE, MICH.



# Delightful Comfort

Nowhere can a person secure more real, delightful comfort on a railway journey than on the great trains over the Lake Shore and Michigan Southern Ry.

And this is due to the equipment—always the best—excellence of road bed and nicety of track adjustment, features wherein it excels all others, and which make every mile one of comfort and pleasure.

When you have occasion to travel between Chicago and Cleveland, Buffalo, New York and Boston, by using the Lake Shore you will secure absolutely the best in travel that money can buy. For "Book of Trains" or travel information, address

A. J. SMITH, General Pass. and Ticket Agent, Cleveland, Ohio.



**"FOR 34 YEARS A STANDARD PIANO."**

# THE WING PIANO

**YOU NEED THIS BOOK** IF YOU INTEND TO BUY A PIANO. A book —not a catalogue— that gives you all the information possessed by experts. It makes the selection of a piano easy. If read carefully, it will make you a judge of tone, action, workmanship and finish; will tell you how to know good from bad. It describes the materials used; gives pictures of all the different parts, and tells how they should be made and put together. It is the only book of its kind ever published. It contains 116 large pages, and is named "**The Book of Complete Information About Pianos.**" We send it free to anyone wishing to buy a piano. Write for it.

**SAVE FROM \$100 TO \$200** We make the WING PIANO and sell it ourselves. It goes direct from our factory to your home. We do not employ any agents or salesmen. When you buy the WING PIANO you pay the actual cost of construction and our small wholesale profit. This profit is small because we sell thousands of pianos yearly. Most retail stores sell no more than twelve to twenty pianos yearly, and must charge from \$100 to \$200 profit on each. They can't help it.

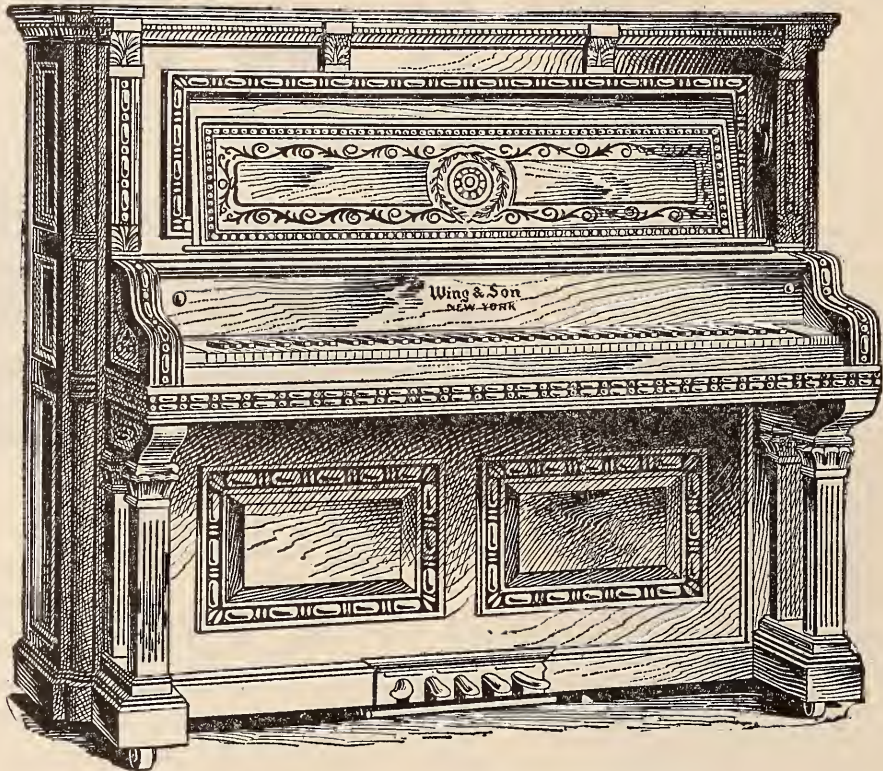

*A Wing style—45 other styles to select from.*

**SENT ON TRIAL** WE PAY FREIGHT. NO MONEY IN ADVANCE. We will send any WING PIANO to any part of the United States on trial. We pay freight in advance and do not ask for any advance payment or deposit. **If the piano is not satisfactory after twenty days' trial in your home, we take it back entirely at our expense.** You pay us nothing unless you keep the piano. There is absolutely no risk or expense to you.

Old instruments taken in exchange.

**EASY MONTHLY PAYMENTS.**

**INSTRUMENTAL ATTACHMENT** A special feature of the Wing Piano; it imitates perfectly the tones of the mandolin, guitar, harp, zither and banjo.

**IN 34 YEARS 33,000 PIANOS** We refer to over 33,000 satisfied purchasers in every part of the United States. WING PIANOS are guaranteed for twelve years against any defect in tone, action, workmanship or material.

**WING ORGANS** Are just as carefully made as Wing Pianos. They have a sweet, powerful, lasting tone, easy action, very handsome appearance, need no tuning. Wing Organs are sold direct from the factory, sent on trial are sold; on easy monthly payments. For catalogue and prices write to

**WING & SON,** 432 and 434 West 13th St.,  
NEW YORK.

1868—35th Year—1903.

Sent on Approval

TO RESPONSIBLE PEOPLE

# Laughlin

## Fountain Pen

Guaranteed Finest

Grade 14k.

SOLID GOLD PEN.

To test the merits of

### RECREATION

as an advertising medium we make this grand special offer, your choice of

These  
Two  
Popular  
Styles  
For Only

# \$1.00

Postpaid  
to any  
Address

(By Registered mail 8 cents extra)

Holder is made of finest quality hard rubber, in four simple parts, fitted with very highest grade, large size 14k, gold pen, any flexibility desired—in feeding device perfect.

Either Style—**RICHLY GOLD MOUNTED** for presentation purposes, \$1.00 extra.

### Grand Special Offer

You may try the pen a week; if you do not find it as represented, fully as fine a value as you can secure for three times the price in any other makes, if not satisfactory in every respect, return it and we will promptly refund your money.

Illustration on left is full size of Ladies' style; on right, Gentlemen's style. Lay this RECREATION Down and Write NOW.

Safety Pocket Pen Holder sent free of charge with each Pen.

ADDRESS :

## Laughlin Mfg. Co.

424 Griswold St., DETROIT, MICH.



The Best  
of Good Company

is always at your command if you've a Combination Table in your home. A handsome library or dining table changed to billiards or pool by removing top. The

### Indianapolis Combination Table

Library—Dining—Billiard—Pool.

is the equal of the finest standard table except in size which is suited to the home. Vermont slate bed, sensitive rubber cushions, imported French billiard cloth, genuine ivory billiard balls, balanced cues. Nine styles.  $\frac{3}{8}$ ,  $\frac{3}{4}$ ,  $\frac{7}{8}$  standard billiard table sizes. The correct table for your library or dining room is among them.

Write for our new illustrated catalogue and full information.  
Combination Billiard Mfg. Co., 33-43 Ingalls Street, Indianapolis, Ind.

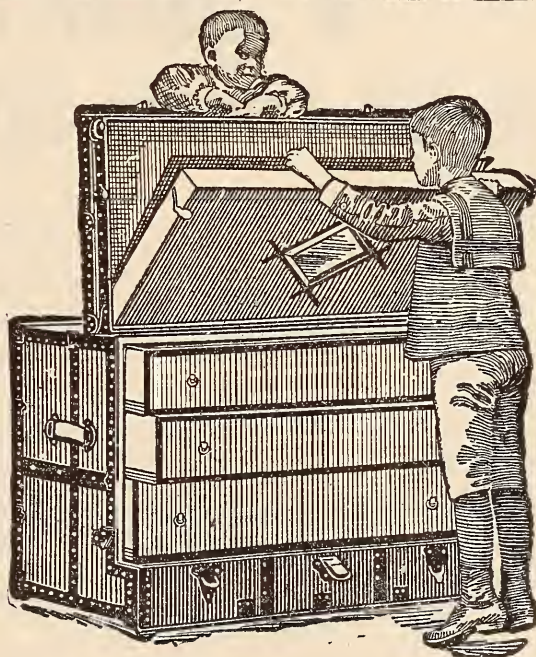
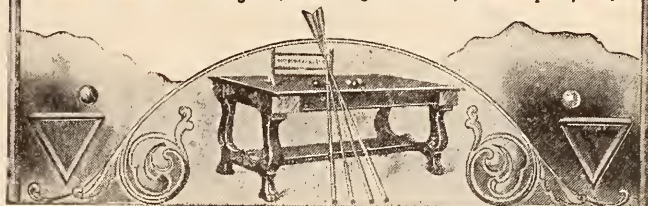

**Stallman's Dresser Trunk** Have you seen one? It is up-to-date. Think of it, everything within reach. No heavy trays, but light, smooth drawers. Holds as much and costs no more than a good box trunk. Hand riveted, almost indestructible. Once tried, always recommended. Sent C. O. D., privilege examination. cc. stamp for catalogue. Mention RECREATION.

F. A. STALLMAN,

87 W. Spring St.,

Columbus, O.

# HAYNER WHISKEY

We are willing to lose money to get you to try **HAYNER WHISKEY**, for we know if you only try it you will always buy it, just as our half-a-million satisfied customers are now doing. Remember, we have one of the largest distilleries in the world. We are the largest bottlers of whiskey in the world. We have more whiskey in our eight Bonded Warehouses than any other distiller in the world. There is more **HAYNER WHISKEY** sold than any other brand of whiskey in the world. We have been in business over 37 years and have a capital of \$500,000.00 paid in full, so you run no risk when you deal with us. Your money back at once if you are not satisfied. Don't forget that **HAYNER WHISKEY** goes direct from our own distillery to **YOU**, with all its original strength, richness and flavor, thus assuring you of perfect purity and saving you the enormous profits of the dealers. You cannot buy anything purer, better or more satisfactory than **HAYNER WHISKEY** no matter how much you pay. Don't forget that a **HAYNER** quart is an honest quart of 32 ounces, 4 to the gallon. All other high grade whiskies are sold in so-called "quart" bottles that require 5 to the gallon. We give give you one fourth more whiskey in every bottle, really reducing our price just that much. We give you both **QUALITY** and **QUANTITY**. There is nothing cheap about **HAYNER WHISKEY** except the price.

**1 QUART \$1.00**  
**4 QUARTS \$3.20**

**WE PAY EXPRESS CHARGES IN EITHER CASE.**

Send us **\$1.00** for **ONE QUART** or **\$3.20** for **FOUR QUARTS** of **HAYNER SEVEN-YEAR-OLD RYE**, and we will ship in a plain sealed package, with no marks to even suggest contents. We will pay the express charges. When the whiskey reaches your home, try it, sample it thoroughly. Then, if you don't find it all right, perfectly satisfactory in every way and better than you ever had before or can buy from anybody else **AT ANY PRICE**, ship it back to us at our expense and your money will be promptly refunded. Isn't that fair? We stand all the expense if you don't wish to keep the whiskey. **YOU** risk nothing. We ship one quart on your first or trial order only. All subsequent orders must be for at least 4 quarts at 80 cents a quart. The packing and express charges are almost as much on one quart as on four and even at \$1.00 for one quart we lose money, but we want you to try it. **WE PREFER TO HAVE YOU ORDER FOUR QUARTS FOR \$3.20 RIGHT NOW FOR THEN WE WILL MAKE A LITTLE PROFIT AND YOU WILL ALSO SAVE MONEY.** But take your choice. \$1.00 for 1 quart or \$3.20 for 4 quarts, express prepaid. Your money back if you're not satisfied. Write our nearest office **TO-DAY**.



Trial orders for Ariz., Cal., Col., Idaho, Mont., Nev., N. Mex., Ore., Utah, Wash., or Wyo., must be 1 Quart for \$1.25 by **EXPRESS PREPAID**. Subsequent orders on the basis of 4 QUARTS for \$4.00 by **EXPRESS PREPAID** or 20 Quarts for \$16.00 by **FREIGHT PREPAID**.

ESTABLISHED  
1866.

**THE HAYNER DISTILLING COMPANY,**

**DISTILLERY  
TROY, OHIO.**

**DAYTON, OHIO.**

**ST. LOUIS, MO.,**

**ST. PAUL, MINN.,**

**ATLANTA, GA.,**







HE WAS UTTERING HIS WEIRD CALL IN TONES AS INSPIRING AND AS MUSICAL AS THE NOTES OF A FLUTE.

# RECREATION

Volume XIX.

SEPTEMBER, 1903

Number 3

G. O. SHIELDS, (COQUINA) Editor and Manager

## HUNTING ELK IN A WINDFALL.

E. B. SHANKS.

It was a warm afternoon late in September when we left the trail and plunged into the hills, looking for a desirable camping spot. We finally unpacked well up among the ridges West of the Buffalo fork of the Snake river, in Western Wyoming.

We had lived on salt side for some time, and were hungry for fresh meat. My friend Parker, of Galesville, Wisconsin, was anxious to at least see a band of elk at home in their mountain range. All the other boys had either secured game or had had the opportunity and had sinned away the moment of grace before fully realizing what they were doing. We had made a long trip and were anxious to get back home, but I sympathized with Parker. I proposed that we start early the next morning for a timbered gulch 5 miles to the Northeast of camp, right up in the mountains. We busied ourselves the rest of the afternoon making camp comfortable and getting ready for the hunt. Sunrise found us on the way. By 3 p. m. we reached the head of the stream where the water came trickling down over the rim rock from the heavy drifts of snow and banks of ice that seem eternal there.

It was an ideal place for game, and I cautioned Parker to be prepared to meet a grizzly face to face and to be ready with his rifle to shoot quickly and with his nerve to shoot steadily. We advanced a few steps at a time, then paused and closely scrutinized everything about us. I was a few feet in advance. Looking about, I became suddenly aware that we were

in the midst of a splendid band of elk, quietly feeding. I had previously determined to do no shooting. I threw myself flat on the ground and at a sign Parker did likewise. I then directed him to advance a few paces to a large boulder from behind which I felt sure he would be screened from sight and at the same time have a better view of the band. Parker was a true sportsman and had determined to shoot at nothing unless it wore antlers. As I crawled to his side he said deliberately,

"There is not a bull among them."

I could not believe this, as the band numbered about 30.

"Yes, there is, too!" he exclaimed, jumping to his feet. He raised his Savage and fired.

"I missed him, sure," was his next remark. He was shooting at a sleek, fat, 2-year-old bull that had deliberately crossed through between some evergreens in front of us. The bull soon emerged into view again, a little farther away, apparently not even startled.

"There he is!" from Parker, followed by the crack of his rifle again.

"I have missed him again!" he exclaimed, as the buck again disappeared, only to reappear a little farther on, to receive another broadside and to disappear again.

The band was startled, but had made no effort to run away, as they had neither seen us nor winded us. Cows and calves were all about us, sleek and fat, but they were safe. We had not come after them.

I was intently watching them and

the other details of our surroundings, drawing inspiration at every breath from the beautiful scene, when I was surprised at a shrill peal from the silvery bugle of the "lord of the band." Looking to the left, up close to the lake where an opening in the forest allowed the sunshine to stream down about him, I saw an immense bull, with a set of magnificent antlers. With his head thrown well up, he was uttering his call in tones as inspiring and musical as the notes of a flute.

Those of the band near him made toward him, and turning, with steps as proud as an emperor's and without even breaking his walk, he strode off down the gulch, followed by the band. They never saw us. Retreating leisurely and falling in behind the others, all followed their gallant leader and disappeared from view in the forest below.

We walked slowly after them, Parker bewailing the fate that had lost him the spike bull and had deprived the camp of fresh meat. We carefully examined the ground his target had so leisurely passed over, for some traces of his bombardment. We found where some of the bullets had struck, but farther than that we could find nothing.

"He was just about to disappear behind those evergreens this side of that big log as I took my last shot at him," said Parker as we turned down the gulch.

"Better look the other side of the log," I suggested. "You will probably find him there." Parker looked at me incredulously, but started for the log. As he reached it he wheeled about, jerked his hat from his head, waved it and joyously exclaimed,

"He's here!"

This was good news, as it meant meat, in addition to the royal sport we were having.

We prepared the buck for transportation to camp and resumed our homeward journey. We had scarcely gone 100 yards when we made the

discovery that we were surrounded, actually hemmed in, by a covey of mountain grouse. We enjoyed a few moments of rare sport, shooting off heads with our rifles, as they swayed and bobbed unsteadily among the branches of the evergreens.

We left them after securing a brace apiece. Parker was carrying the liver of the elk just killed. We followed down the gulch, picking our way over so much down timber that we were doubtful about reaching the game we had killed, with the pack horses. We emerged from the timber on open ground just as the sun was setting.

Sitting down on the last log crossed, we rested and were enjoying the scene before us, when a band of 8 cow elk came over a hill between us and the river, half a mile away. The band was about 300 yards away, coming straight toward us up the mountain.

They had advanced into sight but a short distance when we observed, a little to the left and nearly parallel with them, a large bull coming leisurely in our direction.

"Had I better shoot at that fellow?" said Parker, looking intently at the bull, which was then about 225 yards away.

I was undecided what to say. It was probable we could never get a pack horse up to where he had killed the other elk. Here was a chance for him to get a set of horns and at the same time get meat that there would be no trouble in packing into camp.

"Yes, let him have it."

Parker dropped on one knee and fired quickly. The bull turned and walked toward the cows, picking his way as if his feet were sore.

At the second shot he humped his back slightly. The third shot was fired as he was nearly out of sight in a slight depression in the ground. Parker was terribly chagrined, thinking he had scored a series of misses.

After the bull's body had disappeared from sight his horns were still visible. They suddenly disappeared,



IN THE WINDFALL.

and in their place I felt certain I had seen his heels. I consoled Parker by telling him I was sure he had killed his game.

We found the bull lying as nearly on his back as it was possible for him to lie, with 3 bullet holes through

him, any one of which would have killed him.

Next day the meat was packed in. We saved nearly all of it, Parker and Paterson packing most of the first elk on their backs down to where we could reach it with the horses.



YOUNG YELLOW WARBLERS.

AMATEUR PHOTO BY R. H. BEEBE.

One of the 18th Prize Winners in RECREATION'S 7th Annual Photo Competition.

## SONG OF THE HUNTER.

F. D. A. WALKER.

Away to the hills and the wooded dell,  
Where woodcock, grouse and squirrels  
    dwell;  
To the haunts of the fox, who from his lair  
Steals on the unsuspecting hare.  
Where stately trees their shadows cast  
On crystal stream that, rippling past,  
Hides deep within its rushing tide,  
The speckled trout, the sportsman's pride.

Away to the forest old and grand,  
Where ancient oaks and maples stand,  
On cragged steep and mountain drear,  
Where lives in peace the timid deer.  
O'er reedy marsh and quaking bog,  
By quiet lake, with gun and dog,  
To hunt the water fowls so shy,  
That all your skill and patience try.

Then come with me, bring dog and gun,  
For the hunting time has now begun;  
And when the morning's early light,  
Steals through the darkness of the night,  
We'll start for the hills and the wooded  
    dell,  
Where woodcock, grouse and squirrels  
    dwell;  
To the haunts of the fox who from his  
    lair,  
Steals on the unsuspecting hare.

## SOME FEATHERED FOLK.

MARTHA M. WILLIAMS.

Tom Coffin was the most engaging of them all, a cardinal, trapped in time of snow, and as full of fight as any real cardinal that ever ruffed it in the red robe. It was his fighting quality indeed which earned him his name. Cooper's Tom Coffin never fought more gamely. The red bird bit his captor's fingers almost to the bone before he suffered himself to be

to think they would be the finest sort of eating if only he could manage to get them loose. When his cage was set open he would fly out, and across the room, to perch on her finger, where he would ruffle his red throat and twitter loudly, if she said, "Tom, tell me good morning."

A water bucket sat, always open, in the back hall, some little way off the room



taken from the trap and after he was caged, would ruffle his feathers, drop his wings, make a loud, scowling noise, and try to peck the eyes of any head which came incautiously near the bars.

A week of kindness changed all that. He quit scolding when approached, twittering a welcome instead, the while dropping his wings in gentle deprecation. By and by he grew so tame he was given the freedom of the whole house. It was pretty then to see him fly upon the head of his mistress, gently tweak her hair, then make a fluttering hop to her shoulder and peck at her earrings. The earrings were tiny golden half moons, and Tom Coffin seemed

TOM'S ORCHARD NEMESIS.

where his cage hung. Tom often hopped upon the bucket's rim and balanced there daintily a minute; but never tried to touch the water even when the bucket was so full he might easily have sipped it. But as certainly as water was left standing in a shallow basin on the table beside the bucket, Tom plunged into it, splashing and spluttering to his heart's content, seeming to prefer it infinitely to his own bath inside the cage. When he came out of the water he hopped laboriously upon the basin rim, stood still a minute, then ruffled every feather and gave himself a tremen-

dous shake. As the weather grew warm he flew in and out at will. Horses grazed sometimes in the yard, and left deep, cuppy tracks in the turf. When the spring rains made of those tracks little clear pools Tom Coffin made a point of bathing in every pool. He sank his little red body clear under water, spread his wings, lay down, now on this side, now on that, wallowing as a fowl wallows in dust, but always keeping his head out, and whirling round and round so as to look on every side of him.

Tom would have been perfectly happy in captivity but for the fact that he had a skulking enemy, a pestilent fellow who lived behind something white and clear and hard, who mimicked every motion Tom made, even to rushing at him with lowered wings, ruffled crest and open bill. Notwithstanding, Tom could never get at him. After a dozen ineffectual rushes, the first time he discovered this mocker, Tom walked first to one side, then the other, of the hard, white, shining thing that kept them apart, peeped behind it several times, then turned away puzzled, only to find as he walked back in front of the white thing that the bird he could not find was there again. After 2 or 3 further ineffectual rushes, Tom withdrew a little way, scolding loudly. He saw the other bird also scolding, raising and lowering his crest, his throat pulsing in a loud chittering skirl. Tom turned his back contemptuously on the coward, flew off to his cage, hopped upon the highest perch there, and sang his loudest and most triumphant song, stopping every little while to hear if the other bird was also singing. At length, however, he became satisfied that the other fellow was out of it, and though he never failed to fight a bit when the 2 came face to face, it was evidently not a real battle; only a sham one to save the situation. After a dash or 2 Tom flew away, to a tree outside, or to the top of a tall window, seeming to say in song, "Really, that fellow is beyond endurance, but you see I have punished him as he deserves."

A red winged blackbird made himself exceedingly conspicuous about the house, and more especially in the marsh below the orchard, during a part of Tom's sojourn in the family. He seemed to take delight in bantering and teasing Tom, though he may not have meant his visits in that way. His call seemed discordant and defiant, whatever his meaning may have been. Tom was always ready to accept the challenge, if it were such, and that no battle was really fought was due to the fact that this red winged visitor seemed to believe in the old adage that the bird that calls and flies away may live to call another day.

Tom's courtship was high comedy with a tragic ending. In April his cage was

swung in a damson tree some little way from the front porch and the door was propped open. Tom slept in the cage every night, though by daylight he ranged the whole orchard, garden and hedge row.



FLIRTING.

The second day outside his mistress found him flirting with a small, very shy, brown red person, who flitted out of sight almost the minute she was seen.



A BED OF ROSE LEAVES.

But she came almost to the cage with Tom when he sought his perch, and answered his sleepy love calls in plaintive



tremolo. Still it took him a week to coax her inside the cage, and once there she shot out when somebody laughed on the porch. The next day she fluttered all around, but would not go in, though Tom was hopping in and out, carrying bits of bark and sticks, in sign that he thought it high time nest making was begun. All the while he called to her and was answered. Toward sundown another cardinal began calling love to the little brown red thing. She set her head doubtfully on one side and piped a weak answer. Tom heard it, dashed out of the cage and at the intruder, who was flying toward the damson tree. At once the 2 clinched, tussling so fiercely they fell to the ground. A big stray cat, gaunt and white, darted from the ambush of the garden fence, tried to catch both birds, did catch poor Tom, and before he could be forced to drop his prey so mangled Tom Coffin that the bird died in 5 minutes.

Of course, Tom had a fine funeral. His mistress wrapped him in a linen napkin and laid him away in a cigar box, cushioned with pink rose leaves. The grave was at the foot of a big rose bush, and



LITTLE DORRITT AND HER LORD.

every year drifts of the same pink petals lie heaped above it.

Little Dorritt was a hedge sparrow, the meekest, mildest creature that ever was victimized by a hectoring, peevish mate. She had a dreadful time building her nest. It was begun first in a gooseberry bush,

handily low, yet well fenced about with thorny stalks. She worked there half a day, carrying in grass and fine roots and industriously weaving them together. Her lord, meantime, after fetching a single stick, sat scolding and raising his feathers amid the raspberry bushes just beyond. Toward afternoon he made a dash at the nest, plumped down in it, and with beak and wings wrecked it completely. Then, with his mouth full of fragments, he flew out and away to a stubby swinging syringa bough, flung down the nest stuff insecurely in a small crotch of it, and set up a hoarse twittering, full of command.

Little Dorritt followed him meekly, bringing with her other fragments of her ruined nest. When she dropped them in the nest crotch and began whirling around to weave them in place, her mate pecked her and sent her flying, then hopped into the new nest and began arranging it to suit himself. He kept this up until it was finished, never letting poor little Dorritt set one twig or hair to please herself. There is no denying he was a good architect. The finished nest was round and firm as a cup, beautifully smooth inside, and lined with the softest, finest hairs. But it would have been hard on the little wife if those watching the family's establishment had not pitied her to the degree of putting much nest stuff, fine curving grass stems, roots, hairs and soft string where she could lay beak on them without flying more than 20 yards.

Possibly she grew wonted to the watchers in the flying, or it may be she felt the helpful impulse of strength so much greater than her own. Certain it is, that as she brooded her 4 greeny blue eggs she never resented a friendly presence, but sat on the nest to be looked at, and would take worms or cherries from the hand if it approached her over her shoulder. Then she lifted her beak, opened it and twittered faint thanks. But if the offerings came facing her she drew her head back, tucked it down even with the edge of the nest and sat shivering all through. She grew to like having her back stroked gently with one finger. Whole cherries she could not swallow. They had to be seeded and pulled in 2. Even then she ate them under protest, but slugs and cut worms were her delight. She swallowed 7 big cut worms, 3 slugs and a dozen flies once within half an hour. At least, her human friends gave her that number at short intervals, and her cantankerous mate, no more cantankerous, but most anxious and lover like, fed her others between times. As his was not the temperament of self denial, the people in watch decided that a pair of active sparrows must consume



THE CACHE.

every day about twice their own weight in insects, not to name grass and weed seed.

Belial was a thief; whether from nature or environment is uncertain. He was also a jay, and further, a popinjay, with an abnormally developed taste for gauds and gewgaws. Red things, shiny things, appealed to him irresistibly. He was hatched, and lived all his life, among some tall oaks in the back yard of a bachelor's establishment. The bachelor was somewhat a sportsman, also somewhat rheumatic. As a consequence he wore red woolen next his skin. When the garments hung drying on the line Belial flew down to peck at them, and sometimes, if they were worn a bit, to tear them and fly triumphantly away with a red strip fluttering in his beak. He also carried off buttons, empty cartridge shells, fragments of looking glass, bits of tin, and silver spoons if he could get them. That happened not infrequently until the black housekeeper learned his habits. She was given to washing dishes out in the shade of the oaks, always took her time

over the work, and sometimes also took naps. Belial darted down then, snatched a spoon, dropped it if he found it too heavy and picked a lighter one. For long nobody in the least suspected him. He might never have been suspected, indeed, if he had not been caught in the act of trying to fly away with a child's toy tin cup.

Then the trees, all his haunts indeed, were searched for stolen goods. Nothing whatever was found. What became of his pilferings threatened to be a standing mystery, but was solved in the end by a lucky accident. There was a dead tree full of woodpecker holes in the edge of the woods 100 yards away. It blew down, split partly open in falling, and there, plain to view, in one of the holes, was a mass of gay colored bits, tangled up with other bits that shone. There, too was Belial, fluttering above the fallen trunk, shouting with each wag of the tail, "Ja-ay Raa-ait! Jaa-ay Raa-a-ait!" as who should say, "Things are at a pretty pass when an honest fellow must lose his small accumulations this way."

---

Mrs. Muggins—Did you hear about your neighbor? She was overcome by coal gas.

Mrs. Buggins—That's just like them. I suppose they were afraid people wouldn't know they had coal.—Philadelphia Record.

## A DEER HUNT IN MEXICO.

J. K. EICHHORN.

I have been an ardent hunter from boyhood. I was born and raised in Germany, where a possible inherent destructiveness of the young huntsman meets its first check by the law, if from ethical reasons he feels not constrained to keep from brutalizing himself. The game laws are enforced and executed, as all German laws are, with promptness and precision. I am thoroughly in accord with the spirit of RECREATION, of which I have been a reader for years.

In the main range of the Sierra Madre mountains, in Mexico, deer and turkeys are abundant. The deer there are all white-tails, *Cariacus virginianus*, though only a little farther to the North and still in this State, as in Sonora and Coahuila, the blacktail or mule deer, *Cariacus macrotis*, "*venados burros*," as the natives call them, may frequently be found.

The wild turkey in these latitudes grows, I am told, to a size unusually large. My friend, Boon Barker, a hunter who has his superior nowhere, and not many equals, and who never deviates from the truth in a hunting story—yes, quite right, Mr. Shields; a remarkable fellow—has stated to me that a year or 2 ago he saw a gobbler, dressed, shipped through here by express and marked 18 kilos (about 39½ pounds) as his weight. On a hunting trip which I took with Boon Barker 2 years ago I shot the first and only turkey I have ever bagged, and he weighed not less than 35 pounds, dressed. His home and harem lay in the beautiful Sierra Banderas, 1½ days' horseback ride West of Guatimapé, a station about 3 hours' ride by rail from Durango. If this statement of weight be throwing a bone of contention among my brother Nimrods, all I would say to them is, "Come down here and do likewise!"

Occasionally bears, black, cinnamon and silvertip, are encountered. On the above mentioned hunt, lasting 32 days, Barker shot a 3 year old cinnamon she bear, fur in fair condition, in the Sierra Candéla, a 2 days' horseback ride Northeast from Santiago Papasquiaro. He saw 8 bears during that trip, including a black bear with 4 cubs. After the elusive turkey, bear certainly is the shyest game on foot.

August 20, 1902, I laid low with the first shot ever fired from the new barrel on my 45-90 single shot Winchester a fine 3 year old buck, and by way of initiating the excellent Marble hunting knife you gave me, plunged it into his sticking place. I have dubbed the 45-90 single a gentleman's rifle *par excellence*, because it does not even suggest wholesale slaughter of game, which

your rapid fire, smokeless, high power magazine guns certainly do; and this 45-90 serves well all legitimate, pleasurable purposes of hunting. I had followed this deer, in territory about 6 miles from here, 2 consecutive days over an area of probably 3 square miles, which he inhabited as the only one of his tribe, and had seen him 5 times before he gave me a shot. The sixth time he stood less than 100 yards away, looking at me from behind a huge Spanish dagger plant, his fine head, only, exposed, with horns in the velvet. I thought I was close enough to detect fright, but above all, utter amazement in his large, expressive eyes, over this sixth reappearance of that 2 legged creature, his arch enemy, whom he had probably concluded an apparition.

I sank down on my right knee, aimed where I thought his throat or his brisket must be, and let fly. I had a hollow point cartridge in the chamber, the efficiency of which I wished to try on game. At the roar of my rifle, the buck wheeled like a flash and disappeared with a few bounds, flag down and head stretched in line with his body, over a slight rise of the ground. That flag staying down and a certain heaviness in his locomotion assured me that my aim had been true. I went over the rise, and 40 steps from where he stood when I fired lay my noble quarry, in such a pose as famous sculptors might have gloated over. His handsome head faced his last tracks, and he rested, slightly inclined, gracefully against the sturdy trunk of the plant, as if in sleep. I confess I have never shot one of these beautiful creatures without, when 'twas done, feeling remorse; yet I have earned all the deer I have ever killed if hard, persistent tramping and other exertions count for aught.

A big pool of blood had scarcely discolored the dark, rusty red sand under the buck's black, delicate nostrils. The bullet hole was about 3 inches back of the right shoulder and ranging almost straight to the opposite side. The ball had pierced the upper part of the heart and a lobe of the lungs, making its exit apparently in 2 parts; as 2 holes, ¼ of an inch apart and each of the size of that made by the entering bullet, indicated. The skin, when taken off, proved much bloodshot, from back of the ears to within 10 inches of the root of the tail. There was also an undiscolored stripe, 6 inches wide, from the brisket back to the end. The knife brought not over an ounce or 2 of blood.

Yes, my shot was a chance one.

The less pleasant aftermath over, and no trees being near, I covered my venison well with brush, after having pried open the breastbone and inserted a stick to admit as much air as possible into the carcass. Then came a pipe, over which I was caught by dusk.

Darkness has a habit, in these parts, of following close on the heels of twilight. It was pitch dark when I mounted my horse. I gave him the reins and he showed much sagacity in taking me to the home of my friend Barker, which I reached about 9 p. m.



AMATEUR PHOTO BY A. BURRITT.

A REMARKABLE REFLECTION.

Bridge over Mahoning river, Lowellville, Ohio. Taken just before sunrise.

SEPTEMBER.

L. C. ELERICK.

There's a dreamy haze o'er valley and hill;  
 There's a hush in the ambient air;  
 There's a quieter tone to the rollicking rill,  
 And a peacefulness everywhere.

On the forest leaves is a touch of gold,  
 And the red and the crimson show  
 That another summer is growing old,  
 And calmly preparing to go.

The song of the wish-ton-wish no more  
 Is heard 'neath the aging trees;  
 The oriole passes a continent o'er  
 And sings by the Southern seas.

The swallow has gone, and the bluebird  
 demure,  
 And the finch with bright red breast;  
 And with happiness, quiet and holy and  
 pure,  
 All nature is sinking to rest.

## RAFTING ON THE ST. JOE.

GEO. H. ROOT.

Photos by the Author.

I had been often told that a trip down the St. Joe was a perilous undertaking and that few who made it cared to repeat the experience. But the love of adventure, and a desire to be out of doors got the best of me. Early in September, 1901, I, with F. J.

Our first day out was uneventful. It began to rain as we started. On top of the divide between Placer and Slate creeks, we ran into a stiff snow storm, but the trail led most of the way through heavy timber which protected us. That night we

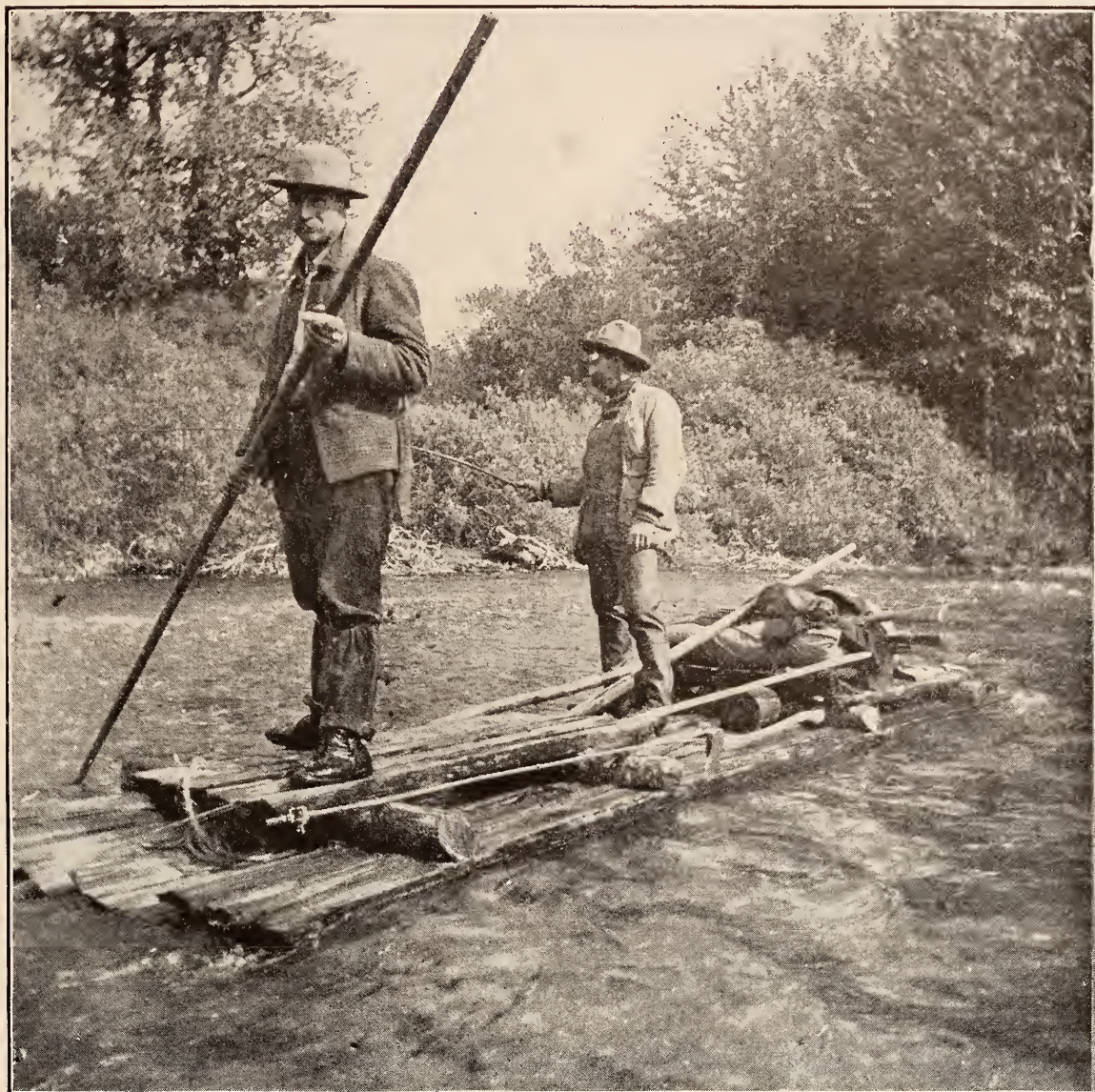

THE START.

Martin and Geo. T. Atteberry, left Wallace, Idaho, to cross the Bitter Root and strike the St. Joe river about 60 miles above where it empties into Lake Cœur D'Alene. We engaged Ralph Sebastian, an experienced packer, to carry our outfit to the river. For company on the return trip, Ralph took along a chum of his, named Kemp, as gritty a boy as I ever met.

camped on the divide between Placer and Slate creeks. The next morning being clear and bright we went on.

About 4 miles down the creek the trail zig-zags up a steep mountain. There it was that Martin decided to follow the creek to the river, which we supposed was distant about 7 miles, George and Kemp went with him, while Ralph and I, with

the pack horse, essayed the climb of what seemed to me the highest and steepest mountain on earth. When about half way up, it began raining; by the time we reached the summit it was dark and the rain had turned to snow and sleet, which, driven by the wind, penetrated our mackintoshes as if they were cheesecloth. But we had promised to meet the boys at the

appearance on arrival at our camp next day, the boys must have spent as unpleasant a night as Ralph and I had.

It seems that the place where we separated was fully 14 miles from the mouth of Slate creek; but thinking they had plenty of time, the boys took it easy and night overtook them half way to the river. There the canyon becomes narrow and



LARGEST CATCH ON THE TRIP.

mouth of Slate creek. We got out some candles and 2 small tin pails, which, with holes punched in the sides to stick the candles through, made good enough lanterns to travel by. With their light we made the descent. Reaching the St. Joe about midnight, we signaled for our companions several times by firing a shot gun. As we heard no reply we stretched our tarpaulin and turned in.

Meantime, according to Martin's version and judging from their dilapidated

the creek rapid; and having no light the boys were compelled to camp under the sheltering boughs of a cedar. They were wet to the skin, from the rain and from crossing the creek many times during the afternoon. One had a RECREATION waterproof matchbox, so they were able to make a fire, or a smoke, as Kemp called it. And there on a bed of rocks, just at the edge of the roaring stream, they passed the night.

Next morning they washed their smoke-

grimed faces, lit their pipes in lieu of breakfast, and started for the St. Joe. They reached our camp about 11 o'clock, just in time to help empty a kettleful of bacon and beans that I had prepared.

The afternoon we spent building our raft. We cut 2 dry cedar logs 18 feet long and about 14 inches in diameter, split them, spiked on 4 strong crossbars, built an upper deck with split cedar boards and were ready to set sail.

Late in the afternoon it cleared a little, and after whipping the stream about an hour Martin and George came in with 3 trout. This stirred Ralph and Kemp to emulation, and with a willow pole, a bit of line, and a white miller that I gave them, they went 200 yards down stream and returned in 30 minutes with 12 one-pounders. Our supper that night was surely immense; in the language of the Florida kid, "If I ever et anythin' that good before I kaint recollect it."

Next morning we rolled our outfit in 2 tarpaulins, placed them on the upper deck on the raft, made both fast with rope, bid Ralph and Kemp good bye, untied our anchor line and were off. Where we launched our raft, the St. Joe is about 80 yards wide, and there is a long stretch of rapids just below. We had provided 3 long cedar poles for steering and 2 paddles for still water. As we moved from the bank toward the main channel, our light raft was caught by the swift current and carried along at great speed.

A feeling of mingled awe and pleasure kept us silent until we had shot the rapids and were gliding placidly on smooth water. Other rapids came in quick succession and we soon recovered from our first nervousness and felt at home on our raft.

Martin rigged his split bamboo, and at the first cast reeled in a big trout. This was more than I could stand and I was soon his first assistant. Poor George, who had never caught anything but catfish, back in Missouri, did not take readily to trout fishing. Every time he got a strike he tried to yank the fish's head off. By noon we had all the trout we wanted; so, heading for shore, we were soon landed and all hands busy around the camp fire.

Late in the afternoon we went aboard

and ran down to the mouth of South Fork, or Marble creek. There we found some wickiups, built by a party who had preceded us, and tied up for the night. After passing Marble creek the trout were so plentiful that, as Martin said, even a Missourian could catch them. But when George landed the largest fish of the lot, Martin was mad.

Our bill of fare on the trip consisted of grouse, ducks and trout, with bacon and beans, flapjacks, and an occasional pudding on the side.

The next few days were spent in drifting with the current, and a royal time we had. We had been cautioned about the danger of going over the Hysterical, Black Prince, and Hell Gate rapids. We had expected to let the raft down over them with a rope. But Martin had become so expert with the pole, that we ran the 3 rapids without mishap. Our only accident occurred when, as I was standing on the rear end and poling in opposition to Martin, we ran head on a big boulder, and Martin was pitched about 10 feet forward into swift water. He did not say a word, but the look he gave me expressed his thoughts.

The first sign of civilization we came across was at Elk prairie, a few miles above slack water. Just as we rounded a bend in the river, we saw a tent on the bank and a man emerging therefrom, who hailed us with a cheery "Hey there! come over and have a jolt." The echo of his voice had barely returned from the opposite bank, when George and Martin were pulling wildly for the shore. The "jolt" consisted of about 2 inches of good whiskey in the bottom of a tincup.

We learned that a man coming down the river the day before in a canoe, had killed a bear 2 miles above the camp; also that it was the 14th bear killed that fall between Marble creek and the head of navigation, a distance of 35 miles.

In a few days we were at St. Joe, and it was like parting from a friend, when we transferred our baggage from the raft to the steamboat. The next day we had a beautiful ride down the river and across lake Cœur D'Alene to Harrison, where we took the train for home.

---

Mr. Smith (in street car)—Madam, take my seat.

Mrs. Jones (who has been standing 15 minutes)—No, thanks. I get off at the next corner.

Mr. Smith—That's all right. So do I.—  
Chicago Journal.

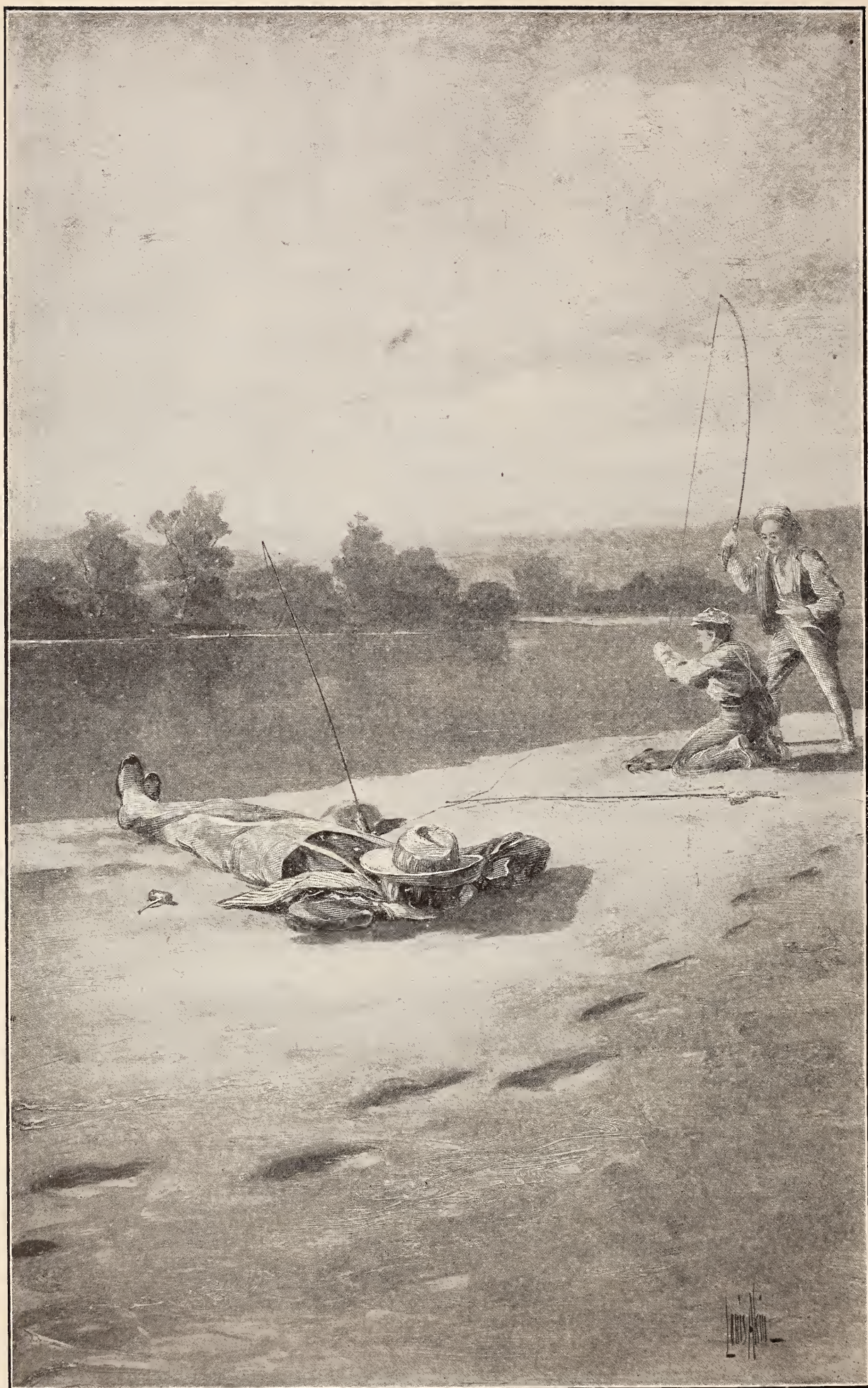

"I CAN GO TO SLEEP AND CATCH MORE FISH THAN YOU CAN, AWAKE."



## CATCHING A CATFISH.

F. D. GREENE.

One September day, a few years ago, Elmer, Joe and I went to the Ore Beds, a fine bit of fishing water in the Des Moines river, 14 miles from town. We had procured bait the previous day, and at 3:45 we were off. Bristol steel rods, wading pants, dry clothing in case of accidents, minnow seine, horse feed, lunch, etc., filled the wagon box. A few minutes' drive took us to the creek where our bait had been planted. I hastened to where we had sunk the pail, at the roots of an overhanging tree, where the water was about 4 feet deep. A strong twine tied the pail to the roots of the tree. Grasping the tree with my left hand I reached down to untie the cord. I weighed 200 pounds. The earth crumbled, and with a tremendous splash I went to the creek bottom. I scrambled out and carrying the pail with me returned to the wagon, the water running off my clothing in streams and sloshing in my boots. Of course my appearance was the signal for hilarity, but I climbed in and we drove on.

The other boys were more experienced anglers than I, and always delighted in advising me how to hook my bait, how to cast, when to strike, etc. On this occasion my tumble into the creek gave them an opening of which they were not slow to take advantage. I was at odds against 2, but I finally made this proposition: We were to bait up and start even; the last to land his first fish was to be thrown into the river, fully dressed, by the remaining 2; to be debarred from fishing any more that day; to prepare lunch, carry minnows to the others, and, in fact, be at the beck of the others for the remainder of the day.

This proposition was a stunner, but they dared not squeal, so it was agreed to. Arrived at the river, we went down to a sand bar, just touched by the rising sun. This bar was about 3 feet high. Where the river washed its edge it was hard and wet, but the top was dry and warm, and made a comfortable seat.

Rods were put together, hooks baited, and at the word, 3 minnows sailed out and dropped softly in the river. The contest was on. We cast and reeled in, cast again and allowed the bait to drift with the current. Two hours went by and not one of the 3 got a bite.

Elmer had been out late the evening before, and, as the sun grew warm, he became sleepy and finally called out,

"You fellows can't catch fish anyhow. I can go to sleep and catch more fish than you can awake."

He put on a lively chub and sticking

the butt of his rod into the sand bank, with the click on his reel set, he dropped down on the warm sand and was soon snoring comfortably.

Joe and I continued to work every point we knew, but to no avail. Elmer had been sleeping about 15 minutes, when we heard his reel. Instantly he awoke, grasped his rod and struck.

"I told you I could go to sleep and catch 'em," he shouted, as he reeled in a 3 pound catfish. This he slipped on the string which was tied to the handle of the minnow bucket, and which always held Joe's hook extractor.

Joe and I, of course, were quite sore, but took it good naturedly. Elmer baited anew, cast out into the current, stuck his rod in the sand and with a final chuckle and a repetition of his former boast was soon asleep again.

Waiting till I knew he was asleep, I strolled down to where I could cast over his line, and after 2 or 3 attempts, hooked it and carefully drew it in. Joe was ready with the catfish, taken from the string, and setting the hook on Elmer's line into its back, just forward of the tail, we turned it loose, hurried back to our posts and were industriously fishing when, in about 3 minutes there was a terrific buzz of Elmer's reel. With a wild yell he grasped the rod and shouted.

"Listen at that! He's a whale, sure!"

He struck, and holding the butt of the rod against his waist, shouted,

"I'm afraid I can't land him!"

Meanwhile the catfish was making desperate efforts to get away and not being handicapped by having the hook in his mouth, was making Elmer's rod bend and taking out line in his rushes, till he had nearly all of it. Then it became a case of reel in or lose the fish.

Joe and I had rushed to Elmer and were giving him all kinds of advice about handling the "whale"; commenting on its strength shown by the way the rod bent, adding all we could to the excitement, and urging him to land his fish. He was white with excitement, and his face and actions were a study as he carefully reeled in. The catfish was evidently getting tired, and was coming easier every moment. I made a rush for my rod which was stuck in the bank, farther up stream, and Joe followed. It was impossible to say what Elmer would do when he discovered the situation.

In a few moments he brought to view his whale. He stood petrified for a few

seconds till the joke dawned fully on him. Then he was a wild man. Joe waded part way across the river for safety. I rolled on the sand and howled. It was all over with Elmer in a few minutes, but it was hot while it lasted. He tired himself out with the violence of his emotions. Then he sat down on the sand and was quiet a while. Finally he cut out the hook, strung the catfish again and, with a sickly grin, remarked,

"I'll get even with you boys yet;" after which he went to sleep again, but did not put out any bait.

Shortly after he went to sleep Joe caught a small pike which swallowed the hook. He untied the string, with Elmer's catfish on it, to use the hook extractor, and after putting his pike on a separate string, forgot to tie the other one to the pail. The catfish promptly swam away taking the hook extractor with him on the end of the string. I also landed a pike, and when I went to the pail to get bait, I discovered the loss of the cat and the extractor. Thereupon Joe and I agreed to affirm that Elmer had not caught a catfish; that he had not been awake since setting his rod; that he must have dreamed about the catfish; and as we each had a fish to show and he had none, we would make a bluff to throw him into the river, as agreed.

It was about noon, so to make our bluff good, we shouted at Elmer to wake up and get lunch ready. He stood up, stretching and yawning, and asked,

"What are you fellows howling about? Have you caught anything yet?"

We replied that we had, and, as he had

not, he was due to get the lunch ready, feed the team, etc., and then be thrown into the river. He walked up toward us, laughing, and began to talk about his catfish. We expressed great surprise at his story, told him he must have been dreaming, and insisted that he had not moved after he first went to sleep.

He looked at us in disgusted amazement, and walked over to the minnow pail to look at the catfish. Not finding it he began,

"Where is that cat—," Joe broke in, "Oh, come now, Elmer, you can't run any bluff on us. You haven't had a bite and you're due for a bath, so get ready. Your pipe dreams don't go."

Then Elmer raved and hunted for the catfish. Finally he asked Joe for his extractor. Joe said he didn't bring it with him. Then doubt began to grow in Elmer's mind. He fixed the lunch and fed the team, and we ate our lunch with our rods set and listening for the click.

Elmer said little during lunch, but when we announced our intention of throwing him into the river, he rebelled. After quite a talk, we agreed to let that part of the program go.

We had a fairly good catch when we started home, about sundown. As we rolled along the smooth road, Elmer began to recover his usual good nature and talkativeness, and we soon had the whole story. It was a strain for Joe and me to keep straight faces and laugh at proper times, but we managed it.

Joe or I never told Elmer the facts, but we told some of the other boys, and Elmer must have learned the truth later.

---

## BOB WHITE.

IRA SWEET.

How oft have I listened to you, Mr. Quail,  
As you sounded your notes from some  
mossy old rail,

While your wife on the nest knew that  
nothing was wrong,

As she heard your sweet music, that tender  
love song,

Bob White! Bob White!

How oft have I heard you, when summer  
was nigh,

As the gathering tempest quick darkened  
the sky!

While other birds, frightened, all scattered  
on wing,

You chanted your song and defied the  
storm-king,

Bob White! Bob White!

When golden October's soft, halcyon  
days

Brought out the gay hunters to roam  
woodland ways,

And the voice of the gun sounded far o'er  
the plain,

I heard you call softly, again and again,  
Bob White! Bob White!

And when you fell dead at the nitro's sharp  
crack,

I tenderly placed you within the game  
sack;

Then blithely sped on, for from over the  
hill

Came the notes of your comrades, who  
sang with a will,

Bob White! Bob White!

## QUAIL SHOOTING IN KENTUCKY.

A. S. ATKINSON.

My father, W. B. Atkinson, owns 2 pointer puppies, Bilto and Lottie, and I own one, named Point, born January 5th, 1902. I bought my puppy when she was 8 months old. She had been in the field once, when about 7 months old, making 3 points, one on a covey and 2 singles. The next time she was in the field, several weeks before the season opened, she made a dozen points, which she handled with wonderful natural dog wisdom. That time I had my gun for the purpose of letting her hear the noise it made and otherwise getting acquainted with it. When she found the first covey that day, I took the shells out of my gun to make sure I would not shoot. Point held steady, something few puppies ever do, and did not break to wing. I followed her in many hunts like that before our season opened. She worked well on larks and I taught her to retrieve with them.

On our first hunt my father and I had been in the field about 15 minutes when father flushed a covey of quails, the dogs not being near. We followed them; but before we found them again Point made one of those grand old sure looking points, father's dogs backing nicely. I walked in on them and downed one bird, father not being in the rise.

We went after the birds. Point made a fine point on what I supposed a single; but instead out came 2. I made a good double, Point retrieving both singly. Lottie at the same time pointed for father, he bagging his bird.

Point went about 50 yards and again pointed. Father came up thinking, "now if the boy misses, I'll get the bird;" but my aim was good and Point brought the game in proudly.

We went into another field and all dogs found another large covey. I killed one quail. Point went to where it fell and pointed, but broke and began to trail; pointed again, broke and began to trail again. I tried to call her off, but she seemed to know what she was doing. I

went back to where the bird fell but could not find it. I looked around and saw Point coming, about 200 yards away, with my winged bird in her mouth, still alive. I need not say I was proud of my dog.

We hunted our day out, and bagged 13 birds. It so happened that 8 of them were in my coat and 5 in father's. That was not many, but we had as much sport as he who kills more. We found in all about 8 coveys; but most of them were in bad places for shooting. Some we did not get a shot at.

Birds are numerous in Warren county; but where we find them they have a good chance to get away. Every lover of dogs thinks he has an exception in the dog line. I have followed many puppies in the field; but Point is a wonder. She pointed nearly 200 quails last season. At first she was not particular what she pointed. A field mouse, lark, rabbit, ground sparrow, mole, cat, chicken or terrapin, being good enough for her; but she soon learned that birds were the things I sought.

One evening I was out with a friend. I had killed a bird. He and I were trying to teach his setter pup to retrieve. When we were ready to go, I could not see my dog. Almost at the same time I saw 3 birds come to the top of the corn and make for the river, which was near. I called loudly, "Steady, Point," not yet seeing her. We walked down to the corn and about 25 feet in the corn she was stretched at full length on the remaining covey of about 18 birds. I have never seen any other dog hold a point after some of a covey had risen.

The last day of our season, Point found a covey of 20 birds. She held them until I flushed. They went into the thicket. We followed. She made a single point and I flushed the bird. She went about 20 feet and pointed again. I came up. Imagine my surprise to find she had pointed a sow and 5 pigs, they being behind a log where she could not see them. When the old sow grunted, Point jumped as if she had been shot.

---

Tourist—When does the next train start for Cork, porter?

Irish Porter—She's just gone, sorr.—Exchange.



THE DOCTOR PULLED UP A GREAT SILVER-SIDED EEL.

## A LEAF FROM THE LOG OF THE ROSAMOND.

CHAS. VAN BRUNT, JR.

All the long September afternoon the white yacht had swung idly at anchor, coquetting with the ebb tide and the South wind. On board all was quiet. Leaning against the rail of the companion way sat the skipper, reading. Tall, stalwart, and grey whiskered, he looked a typical old-time yacht captain. Scattered about the waist outside the cocksprit was a varied collection of rods, reels, lines and nets, proclaiming the mission of the craft. On top of the cabin lay a man asleep. When the sun was nearing the horizon he sat up, and leaning over, called down the companion way:

"Say, below! If you fellows expect to catch a bass at the turn of the tide, it's time you were moving."

"All right," and with the reply 3 men came tumbling up and began a hurried examination of reels and lines.

After a time the lines were entangled and wound snug, bait was put into the boats and we swung away from the yacht. Billy in a boat with the captain's son, who had joined the party from the forepeak, started across the flats for a point where bass were supposed to be anxiously awaiting them.

The Doctor, who was the commodore of the club, and who could always "tell a bass bite from that of any other living thing," the civil engineer and I made up the party. Hugging the flats, to avoid the sweep of the tide which went racing toward the inlet, we pulled briskly. Billy and John soon came to grief on the flats. Where they expected to find 10 inches of water, there was only 3, and we could see them, hard aground and half a mile from the desired point, holding a council of war. But we could not tarry; time was precious, and our own troubles were beginning. We had reached the place where we were to turn off from the channel to go over the flats into a thoroughfare where we expected to fish.

Did you ever try to push a boat over the flats in a tideway? A bay man will stand in his boat and push her along almost as fast as you can row, and he seems to need only a heavy dew to float him anywhere he pleases. But just take that oar yourself and see what happens; before you have gone a rod the sand bumps against the bottom of your boat, and the chances are you will have to get out, take the tow line over your shoulder and drag the skiff with her bottom grating over perriwinkle and clam shells the full length of the flat.

By dint of pushing and pulling, we were soon over and quietly rowing through the thoroughfare; avoiding the deep places, and handling the oars as quietly as possible. You can not catch a striped bass by making a lot of noise; he always has his weather eye and ear open. Arriving at the farther end of the thoroughfare where it opened into the bay, the doctor and the engineer were placed on one point and I rowed to the other, a distance of about 75 feet. Fastening the boat along the edge so she could not swing, and getting rod, reel and line in order, a box of cut bait close at hand, and bull's eye lantern lighted and stowed away under the seat, I lit my pipe and sat down to await events.

The tide was still running ebb, the wind had died down and across the 'fore the forms of my companions were silhouetted against the evening sky. A mud hen came out of that somewhere that birds alone know and ran along a little fringe of muddy sedge just beyond the stern of the boat. Two meadow wrens perched on the swaying sedge not 5 feet from me, and sang before they flew away into the shadows that were lengthening over land and sea. The sun had disappeared beneath a sunset cloud that for a moment covered land, and sea, and sky with crimson glory, and tinged the crests of the breakers off the inlet, as with the blood of hapless seamen. The night came on, and still the ebb tide ran. Out of the South came revolving flashes from the light house, and in the West hung Venus, like a golden lamp. Over the sand dunes came the moon of the great gray sea, with occasional whiffs of its seaweed and brine.

Suddenly there was a different pulse in the air, and a whispering all through the sedge and the rushes. Did you ever hear it when the tide turned? The ebb will run on, and on, and there does not seem to be a living thing in all the great waters, until there comes a something you can almost feel, a presence in and around; there is a different sound in the lap of the tide, and the water grows tremulant with the motion of myriads of living things. Not 10 feet away a school of mullet breaks in a foaming rush and gleams for a moment in the phosphorent tide.

A low whistle came across the water from my companions and I knew they were alert. Now for work, for our fishing must be done within 30 minutes. I put on a fresh bait and cast across the tide. There! Oh, pshaw! only a nibbler! Well,

there are poorer pan fish than a half pound perch. Another great rush of leaping mullet, and I cast right in the middle of the swirl; then the rod bent almost double and the reel sang its merry song. A great leap from the water, a rush, and then with slow, careful work I brought to the boat a fair sized bass. Another cast. That time, just along the edge of the flat where the tide swirled. The bait hardly had time to touch the water, before the rod surged and bent. Confound the fish! Would he never stop? Sixty, 80 yards of line he took before the reel stopped. Was he off? No; for with a "zimp" the line tightened, as he headed in another direction, this time against the tide. Ten minutes of work, and then he slowly surrendered, and I lifted a 5-pound bass aboard.

From across the 'fore I heard the Doctor's voice: "There! that is a bass sure! Now I'll show you how to land him."

Then came a noise of splashing and slapping, and a yell of laughter from the Engineer as the Doctor pulled up a great silver-sided eel.

The Engineer landed a fish, and presently I heard the Doctor say: "Confound it, there is another pesky eel. Get your nippers ready and I'll yank him out and—"

Another roar from the Engineer, and the Doctor exclaimed: "Well, if that ain't the biggest fool bass I ever saw. He bit just like an eel."

And so the fun went on for half an

hour until we had 5 bass and a collection of perch, eels and goodies, and it was time to go aboard. The wind came in stiffly from the Southeast, and great banks of fog shut out the stars. Out in the channel we heard the flood tide roaring, and knew it would be a nasty pull back to the yacht.

Out across the flats we rowed; there was plenty of water everywhere. As we pushed through the short grass, zig zag lines of phosphorent fire marked the flight of eels and fish, alarmed by the boat. Over the flats and out in the channel darkness was everywhere save as we caught the flash from the lighthouse that gave us our bearings. Our boat jumped and plunged in the raging water and the spray drenched us to the skin. At length we could make out the yacht; it put new vigor in us and we were soon aboard.

John and Billy came in about the same time, but their's had been miserable luck, a regular water haul.

Bart, the cook, had a hot supper waiting for us, and throwing off our wet clothing and rubber boots, we gathered around the table in the genial warmth of the cabin.

Then we turned in, lulled by the rocking of the yacht and the music of the wind in the rigging, to sleep the sleep of tired anglers. Just as we were slipping off the flats into the deep water of dreamland the Doctor muttered, "You can't fool the boss on a bass bite."

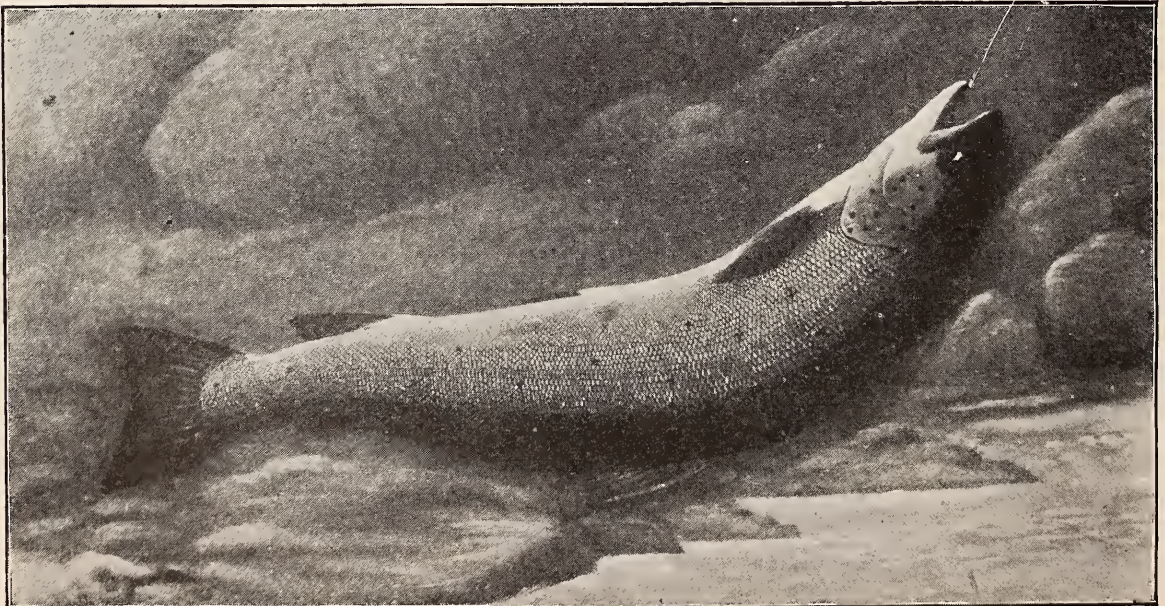

FROM PAINTING BY W. L. STEWARD.

LAND-LOCKED SALMON.

## AMONG THE SANDHILLS.

JOHN MC NEIL.

From Virginia to Mississippi runs a ridge of sandhills, between the red clay of the foot hills and the peaty loam of the Atlantic slope. The soil is poor, except for grapes, and the pine forest and wiregrass hold their ground with little of human interference.

The Seaboard railway, however, rides the backbone of this ridge, from a point near Raleigh to Hamlet, and has induced the growth of villages along its line populated chiefly by section hands and grape farmers. Except for such oases, the sandhills will probably remain a perpetual wilderness, an asylum for deer, turkeys and foxes, so rapidly disappearing elsewhere.

One afternoon, half an hour before sunset, I left the train at Keyser, expecting to be met by a flat country farmer, to whose home I was bent on business. My letter had miscarried and no farmer was there.

"Ten miles to Aberdeen," said the station agent in answer to my question. "That's the closest place to git a hoss."

"How far to Major Tillman's?" I inquired.

"Sixteen miles f'om heah and 20 f'om Aberdeen. Sorry, but you can't git out o' footin' 10 miles at least."

"Well," I sighed, "I prefer to foot 16 to footing 10 and riding 20; so good luck to you!" and with my small grip slung lightly over my shoulder I set out, according to directions, to the Southward.

The sun was half hidden behind the blue bank of cloud that skirted the horizon, and a thousand locusts were rasping the air with their harsh voices. The pure breath of the pine woods exhilarated me. As twilight died into dusk, the katydids succeeded the locust choir; the pines moaned in solemn monotone, so that I felt as if I were among the pillars of some great cathedral; and when the big, yellow moon, like a forest fire, kindled the Eastern tree tops, a whippoorwill in the next valley began telling his pathetic experiences to a listening world.

Those who understand such things say that poetry is that which awakens within us when we hear sweet sounds, feast our eyes on the beautiful, or feel, from any other cause, lofty emotions. I was then full of poetry, awakened by this communion with the soul of nature; but when my legs began to ache with fatigue, and every hill I came to was an exact counterpart of the one I had just crossed, I felt more like composing an ode on the blessedness of sleep than I had ever felt before.

Why not play the role of a hale and hearty huntsman and sleep romantically in the woods, on the lap of my mother, under the eye of my stars and of the patroness of hunters, Diana the chaste, and so on? Accommodations so bountiful and guests so rare, I was sure of my welcome. On the matted wiregrass, with my grip for a pillow, I stretched my listless length.

"How hospitable," I thought, with a sigh, "is nature. She turns her all into your hands. No begrudging, no insistence. She allows you really to feel at home, the last and best accomplishment of a host."

I was half inclined that in the morning I should scatter what money I had on the grass, after the fashion of Stevenson, in order to settle with my invisible landlord. Before I had stared an hour at the moon, however, I decided that Stevenson's night in the woods was of a different color from this one. Time dragged with leaden feet. The fever and fret of that night, with its dews, its mosquitoes, and its chill, called to my mind again and again the stern philosophy of Emerson: "Nature is no sentimentalist. She does not cosset or pamper us. The cold, inconsiderate of persons, tingles your blood, benumbs your feet, freezes a man like a dewdrop. Providence has a wild, rough, incalculable road to its end, and it is of no use to try to whitewash its huge, mixed instrumentalities, or to dress up that terrific benefactor in the clean shirt and white neckcloth of a student in divinity."

I smoked and smoked, saturated the grass on all sides with the aroma of tobacco; but the unconquerable bloodsuckers returned in ever increasing numbers until I was forced to break a tuft of dog fennel and lay about me like Macbeth after Banquo's ghost. The memory of that night, to this day, makes me long for 3 things: all the mosquitoes in a big bag; an idle afternoon, and a blackgum maul.

Though unconscious of having slept at all, I was startled as if from sleep by the uncanny sensation of something cold and moist wriggling over my face. I sprang up and shook myself. It was not a lizard nor a snail, however, but the nose of a bird dog. This herald of humanity was standing near, a picture of penitence, his eyes were full of the "world sorrow" and his tail drooped with expression. I seized him and awaited developments.

Gray morning was beginning to creep out. A few quails, scattered overnight, were calling one another. The crows were

awake. All else, save for the whining of the dog, was still. Presently the expected happened in the form of a shrill whistle, in response to which the dog made a sudden start and broke away, leaving me to follow him as best I could. It was rough work to keep him in sight, but I did it, and after a quarter of a mile of hurrying he brought me up with his fellow hunters. These were a white man and a negro; the former a strapping, ruddy wight, with good nature written in every line of his Scottish face. As for the latter, all coons look alike to me.

"Well, suh, you mus' be lost?" inquired the white man, standing the butt of his muzzle loader on the ground and surveying me in frank astonishment.

When I had explained my situation, he expressed his sympathy by vigorous abuse of Major Tillman.

"He otter be ashamed u' hisse'f!" he cried, "a leavin' you to bruise about in thisher wilduhness all night."

I suggested that Uncle Sam was more likely the one at fault, and changed the subject by asking the nature of their sport.

"Tuckeys," was the reply.

"But it isn't turkey season," I ventured. "Aren't you afraid of the law?"

"I reckon this mus' be your fust trip," he surmised, "else you'd know that the law don't use in these pairts. Who knows when I kill a tuckey? Er who'd tell, s'posin' he did know? We all don't notice the seasons ner the law when we all goes a huntin'. Lemme tell you sump'n'," he continued, after another close scrutiny of my face, "if you know how to keep quiet, we all 'll gin you a little fun to-day."

"I should be delighted," I answered, "but I'm so weak from hunger and fatigue that I'm afraid I can't keep up."

"Fer the bein' hungry, we've got sump'n 't eat; an' fer the bein' tired, you won't hev to do much walkin', fer I know whah the tuckeys stays."

I do not wish to corrupt youth by appearing to countenance the violation of game laws; but put this case to yourself. There was hardly an alternative, so they robbed their pockets of perhaps more than I could eat, and while I attacked them voraciously, we set forward, the master of ceremonies, whose name I found to be Scot Gillis, talking constantly. He told me of the wonders he saw when he went to Fayetteville; of the peculiarities of his nearest neighbors, and how each of them or his ancestors happened to settle in those parts; and, in a spirit inclined toward boasting, of the number and quality of his own cows, hogs, and goats.

"But we-all been kinder onfortunate

this yeah," he confessed. "More so 'n usual. Ev'ry yeah the 'coons an' squir'ls eats our co'n, the foxes an' minks an' 'possums eats our chickens an' pigs, to say nothin' u' the hawks, the niggus, an' the cholery. But this yeah we all been part u' the time burnt up in drouths an' the rest u' the time a mirin' in mud; a mad dog ran among 17 uf our cows an' bit 'em an' they went mad an' raised the foul fien's; one day out 26 hawgs was a layin' in the's bed atween 2 pines, when all at onced the lightnin' struck 'em like a all at onced the lightnin' struck 'em."

There is no imagining when he would have made an end, had not the dog sprung a drove of turkeys and cut short his narrative. Up they flew, some 300 yards before us, with a great roaring of wings and the frightened "tuck, tuck!" which, as Scot later informed me, "made them be called tuckeys." Scot would have made a great etymologist.

The place was covered with a thick growth, consisting partly of oak, and even of some dogwood. How shadowy and cool it was! I did not like to leave that little valley in a senseless tramp after the wildest of wild game.

"Why, Scot," I complained, "they got away without a single shot."

He vouchsafed no reply until we came to the spot whence the fowls had been flushed. He then gave the negro's gun to me, and, calling in the dog, put him in charge of the negro.

"Take 'im way off, Babe," he directed, "an' set a straddle uf 'im. Don't let 'im git away by no means, an' if 'e tries to holler, choke 'im."

"Kin you shoot?" he asked, turning to me.

"I have never tried turkeys," I responded, "but I can tap 8 birds out of 10."

"That'll do. You set right heah, side u' this lawg. Notice that you ar' on the side tordze the turkeys. When I go to yelpin' 'em, if you see 'em comin' in front u' you, don't try to git behin' the lawg. A tuckey kin see the tip eend u' your nose around a tree er over a lawg, but he ain't a lookin' fer you in plain sight on his side u' the blind. An' if you git a shot, don't move till I say so. A tuckey don't min' the smell er soun' u' powder like the sight uf a man."

With these instructions he left me. I sat down in the shade of the log, with a long breath of relaxation, and then everything fell silent. I seemed to be encamped on the turkey playground. Their wallows were all about me, particularly in the soft bed of decayed wood near the log.

At first my surroundings appeared to be entirely lifeless, nothing astir; but before



I had been there 5 minutes a bug began to force his way noisily through the leaves; a bumble bee swang himself heavily up from a tiny nettle blossom and dropped away in search of new sweets; a flying squirrel squeaked and showed her nose and big bright eyes at the hollow of a dogwood, thus unconsciously betraying the secret of her nest; an old snail resumed his proverb-making march to nowhere; there were a thousand stirrings of life which the least movement on my part would have silenced.

I had been at my post some 15 minutes, and my attention was engrossed by the Nimrod spectacle of black ants dragging a worm to their hill, when Scot made a start at his yelping. The sound was not so much like the call of a turkey as a kind of composite barnyard cry, a general mixture of quacking, hen singing, goose gandering, with a small intermixture of a foreign vibration, namely, crow cawing; but it did the work. The yelping was done timidly, as if the yelper were a modest young hen who no sooner spoke her mind than she regretted it and felt like apologizing. It was also brief. Three calls, then a pause; sometimes 4 calls; sometimes 2.

Before me the slope gradually rose for half a mile or more and was for the most part in plain view. As I kept my eyes in that direction I presently saw something top the hill, running. It was making directly for me, and as it came nearer I recognized a well grown turkey. Almost breathless I waited until she ran up within 40 yards of me, when she winded me, stopped, craned her neck, and uttered, as in soliloquy, 2 or 3 low "tucks." I eased the barrel of my gun down till it bore on her breast; then I fired.

Before the smoke had cleared away, Dike, the dog, rushed on the scene, hotly followed by his guardian, Babe. This led to some stiff phrases from Scot, requesting Babe to return to his lair with Dike.

"What 'as the matter? How did you shoot?" Scot inquired.

When I replied, he exclaimed:

"Oh, yes; I forgot to tell you that they 'll shed shot like a duck sheds water. You ort to er waited till she turnt sideways er clean round, an' er stuck the shot in ag'in' the grain. Now set thah again an' fix the next on' right."

After 15 minutes of silence and another 15 minutes of yelping, I caught sight of a gobbler coming my way. His gait was not so fast as the hen's had been, but he walked with more assurance. I put my gun in position and sat perfectly still until he came within 20 steps of me. There he

winded me and called a sudden halt, acting much as the hen had acted. All at once he detected me beyond a doubt, squatted, and spread his wings for flight, just as I threw my load into his back.

Up rushed Babe and his protege as before, this time to some purpose. The gobbler was flopping on the ground in front of us. Babe and Dike threw themselves on him, the former with loud shouting, which he kept up until Scot arrived and knocked the bird in the head. It was easily imagined that Babe in his enthusiasm had given the surviving turkeys a fright for good and all.

This proved true. We lay there for hours, yelping faithfully, but in vain. As the shadows lengthened to the Eastward we set pace on our homeward journey Babe tossed the gobbler over his shoulder, holding him by one foot. How weary was that way! My shoes, polished on the straw and grass, were slick as eels, so that I slipped at every step. I was too proud to confess my weakness to those whose standard of manhood was physical strength; I gritted my teeth and trudged on.

At the top of a high hill my companions stood still and listened. The jangle of a cowbell came to us from the next hillside. That was the sound they had listened for, and I dragged myself behind them thither. Scot drawled a long "Hoo-oo-oo!" with a mellow cadence, in obedience to which the bell cow at once left off grazing and took up a bee line, as the outcome proved, for home. The other cattle fell in behind her one by one, making finally a line of 40 pairs of horns, forty swaying backs, and 160 crackling ankles.

Up the long lane we followed them to the lot, where the Gillis women stood waiting, piggins in hand. How streamed the milk into those piggins! What an experience of pastoral life! It is unnecessary to state whether I held a calf off by the ear. How delicious was the supper of milk and pieces broken from a big, brown, oven loaf of corn bread! It was the best supper I have ever eaten.

Best of all was the bed, on its massive, old fashioned bedstead. It stood between 2 windows, where the gentle breeze, laden with perfume of the soil, orchards and woods, played over it all night. The house was surrounded by huge oaks wherein the katydids perched and sang their lullaby like an audible peace.

There is game in the sandhills, some natural beauty, a few hospitable people, and unlimited health. I shall always be pleased at the miscarriage of my letter to Major Tillman,



AMATEUR PHOTO BY W. A. MASON.

A FOREST FREAK IN STORY COUNTY, IOWA.

## HADN'T LOST ANY BEAR.

BOYD C. PACKER.

A few years since, one of my most intimate friends, whose name is Dave, and who is quite a sportsman, accompanied me on one of my trips to the far West to have a hunt for some of the big game of the Rockies, of which he had read and heard much. At that time I was in the cattle business, owner of the—P.—outfit, and had an excellent range in Western Colorado, where we could always get game. My friend had never met anything more dangerous than a deer or a cottontail. In order to make it interesting to him and show him a good time, that he would remember, I decided to do some trapping, knowing that a big grizzly in a trap would fill the bill for a tenderfoot who had never seen one and would make it as interesting as he would want it. After consulting with the boys we concluded to go to the North fork of the Gunnison, about 75 miles from Delta, to a place known as Pilot Knob, the highest and grandest peak in all that section. The scenery around Old Pilot was magnificent, with large and beautiful parks, and the whole country seemed to be alive with game. Two of my punchers, Henry and Luke, went along to do the cooking and wrangle the horses. Henry was also an experienced trapper. We arrived at Pilot Knob the afternoon of the third day from Delta, after having traveled over some bad roads; in fact, no roads at all, only a trail, but we could see that a wagon had been over it. We pitched our tent at the foot of Old Pilot in a beautiful grassy park close to a spring of pure, cold water. Long before we reached our destination we saw plenty of bear signs, and next day found the woods were full of 'em. We also found what had brought them there; the carcasses of 3 elk that had been killed some time before, on which they were feeding. It looked as if all the bears for many miles had come in there to feed and were staying. Footprints of all sizes could be seen, and some of them very large. Being already baited, we put our traps out at once, and the first night caught a big cinnamon in one and got the toes of a black in the other. The cinnamon did not put up so fierce a fight as I anticipated, after seeing how big he was. In fact we had no trouble killing him. He only took his drag about 50 yards. We thought this was good enough for the first night, and that we were going to have lots of fun, but the next night both traps were sprung and nothing was in them. They were sprung by a trapper who had come in and pitched his tents a few rods from ours. Next day we found the traps sprung again, also found the trail of a man wearing gum

boots, such as our neighbor wore, and were sure then that he had sprung them. We were not long in making it so uncomfortable for him that he was glad to get away with a whole hide or without a hole in his. He offered to sell his trap, and we thought it was only a bluff, but bought it. Probably he thought we were a lot of punchers and not able to buy it. After hunting a few days, only killing 2 elk and a few deer, only one of which we got, as the bears took all we killed except those taken to camp at once, Dave shot a bull elk. It went into a thicket of scrub oak, badly wounded, and as bear tracks were numerous on the trail it went in on, he did not follow, but came to camp and told us what he had done. Henry and I started out and found his elk, dead, and at the same time killed the black bear whose toes we got in one of the traps, and packed it in. That night a large dog that had followed us was driven into the tent by a bear and created quite a commotion. Next day Henry and I agreed to bring in the elk Dave had killed, but we only got the head, as the bears had torn the carcass to pieces during the night. Dave and Luke started off in another direction. We took an extra pack horse with us, thinking we would get another bear in the traps, but were mistaken as they worked on the fresh elk, where there was no trap. I told Henry on going out that I wanted Dave to go to the traps thereafter, and resolved to take him, as it was positively necessary, in order to properly entertain him, to show him a mad grizzly, which we were almost sure to get. One who has never seen a big grizzly under these conditions does not know how active they can be, or how interesting they can make it for the trapper. As I promised Dave a pleasant time, and that he should not get homesick, I felt it my duty to work in a little excitement, and think he anticipated it, for when we got back to camp a note was pinned to the tent saying that he was sick and had gone below. Luke went with him, taking one pack horse. Nothing was apparently wrong in the morning, when we left them. Of course I had to follow, and it broke up what promised to be one of the grandest trapping expeditions I was ever on. I shall always regret it, but as he was my guest, I had to look after him. Before we could break camp Henry and I had to go back and get the traps, which made us late in getting started. We expected to find them 6 miles below at a cow camp, where we had left our wagon. We thought it was the altitude that was too much for Dave, but when we got to the cow camp we

found another message similar to the first. It was nearly dark, so we stayed there all night, starting after them early in the morning. Dave and Luke were at this camp for dinner, as we afterward learned. Dave thought he would catch a few trout in the stream close by, and had only gone a short distance when he saw a bear cross just ahead of him. He said he was not long getting back, and they pulled out as quickly as possible. After following them 2 days we came to a ranch where they had spent the night and there learned for the first time that they were all

right. To say that I was provoked would be putting it mildly. If we had stayed at Old Pilot we would surely have caught several bears. We missed an opportunity such as will never occur again. On the fourth day we found the men. Dave said he "had not lost any bear and was not going to hunt any." I wanted to see Dave face a mad grizzly, but he would not have it that way. I told him the next time we would go for jack rabbits. There was evidently too much bear talk in camp for a tenderfoot.

### JOCK 'O THE GUN.

DOROTHY H. BARRON.

I like to go hunting with Jock a' The Gun  
In the blue September weather;  
He takes his rifle  
And I my pail,  
I look for mushrooms  
And he for quail,  
And rusty coat Don is out for fun,  
All three of us birds of a feather.

Up Mooly Cow lane  
And over the hill,  
Through Puff Ball pasture,  
My pail to fill.  
Don's off and his master must follow  
To the woodland way;  
But he lets me stay  
In the silence of Hemlock hollow,  
And the creeping pine  
Where blue berries grow,  
Trails over the ground,  
And the hemlocks shine,  
And the song sparrow pipes on the top-  
most bough.

I lie and wonder where Jack is now;  
And hear him whistle, and whistle back,  
Then listen and wait for his rifle's crack.  
Once, and again,  
There's a joyous shout  
As Don and Jack  
From the woods burst out;  
And homeward we start together;  
For the day is done  
And the sun sinks low  
While over the hills we saunter slow.  
I like to go hunting with Jock o' The Gun  
In the blue September weather.

### AN OLD TIMER.

Enclosed I send you photo of a Taney county, Mo., Methodist minister. While down there deer hunting last fall I met him looking for a deer he had wounded. You will notice he is a type of the old school hunter, shooting the old muzzle loader and never wasting a shot. He had the misfortune to lose his powder horn and



NEVER WASTES A SHOT.

had no powder to reload his gun, depending on his hound to catch the wounded game. We found the deer and a pot shot put him out of business, a 5-prong buck. Throwing the deer across his horse we started for camp. Being out of meat, we divided the deer and after dinner we got the old gentleman to pose for his photo.

G. W. Elder, Kinmundy, Ill.

Sunday-school Teacher—How many commandments are there, Willie?

Willie—Ten.

Suppose you were to break one of them?

Then there'd only be 9.—Philadelphia Bulletin.

## A FLORIDA KID ON A CAMP HUNT.

CHARLEY APOPKA.

### XII.

The nex' mornin' we was all up an' eatin' breakfast by 3 o'clock, fer we wanted ter be 5 miles from camp by sunup. It was shore cold walkin' through the frosty grass an' my teeth got ter poppin' like a wood-peck a peckin'. Pa said he was goin' where we seen so many turkeys yisterdd'y, an' he took off one way an' Mr. Sam went off another way with 'is rifle. He said he was goin ter still hunt, an Uncle Dick an' me could take old Ring which is the best slow trail dog in the world. We was all ter meet about noon at a big bunch grass perairer, where we'd seen lots of sign an' sevul deer the day before. Uncle Dick an' me made fer a pond we seen the openin' of through the woods. It was all cut up around it with sign of all kinds. We put old Ring on some fresh deer sign, an' he snuffed at em, an' sorter switched 'is tail like he understood, and took off at a slow trot, an' us clost behind. They was 4 deer in the bunch, 'cordin' ter the tracks, an' one of 'em was a big one. I never seen the like of whoopin' cranes. They made sich a fuss I was afeared they'd scare everything outen the country, but old Ring kep' right on, an' led us around ponds an' sloughs, an' after awhile we come to a low place in the woods where the palmetter growed high, as they was lots of gall berry bushes.

"If they ain't in there a layin' down, you kin have my hat," Uncle Dick said, an' shore 'nuff, ol' Ring began ter pick 'is way mighty keerful, an' switch 'is tail, an' we done the same. Direckly ol' Ring stopped an' looked at us, an' went on again, carefuler than ever, an Uncle Dick whispered ter me ter be ready, for we'd jump 'em in a minnit, an' 'bout that time up jumped 3 big old deer out of a bunch of gall berries in 20 yards of us. I fergot ter shoot fer lookin' at their white tails a wavin' look like they was a yard long, but Uncle Dick turned loose 'is old long tom, an shot one down with each barl. When he fired, the fourth deer, which were a tremendous big old buck, jumped out an run past me, an' I throwed my gun on 'is neck an' scored into 'im, an' he turned the purtiest somerset I ever seen, but he jumped up again, an' run into a little scrub, 'bout 300 yards off. One of Uncle Dick's deer never got up, but the other'n started off on 3 legs. She didn't git far, though, till old Ring pulled 'er down, an' Uncle Dick put 'er out of 'er misery with 'is big knife.

They was both big, fat does. We loaded up again, an' hung 'em up, an put old Ring on the trail of my big buck. He took out

fer the scrub, straight's an arrer, an' when he come ter the edge of it, he stopped, like he done before, an' looked back, an' switched 'is tail. We could hear the deer a-breathin' then. He made a sorter rattlin' noise, an' Uncle Dick said I'd shot 'im in the goozle. He tole me ter slip up easy an' finish 'im, soze't I could say I killed 'im by myself, an' he'd be ready with his gun if it were needed. I slipped upon 'im easy, an' seen the ole buck a-layin' on 'is side, a-gaspin' fer breath. Every minnit er 2 he'd throw 'is head, an' I waited till he done it again, an' let 'im have it jest back of 'is head, an' unjointed 'is neck. He jest laid over an' never kicked.

I hollered an' run to 'im ter cut 'is throat, an' 'is eyes looked so sorrowful I hated ter do it, but he was done dead an' it couldn't hurt 'im, so I bled 'im, an' Uncle Dick an' me drug 'im outen the bushes, an' hung 'im up, an' cleaned 'im an' then the 2 of us toted 'im to where the does was, an' he was shore heavy. We cleaned the does an' hung 'em all up in the shade, an' sat down to rest a minnit. Uncle Dick said my buck was as fine as he ever seen, an' that I had beat 'em all. an' he had a mind ter git me 2 rifles, but I tole 'im I'd be mighty well satisfied with one.

Uncle Dick said as near as he could make out, we was 'bout 3 miles ter the West of the perairer where we was ter meet, an' if I didn't mind stayin' by myself a few hours, an' mindin' the deer, he'd go an meet pa 'n Mr. Sam, an' then go 'on ter camp an yoke up the steers an' come on back, an' if you hear a gun fire answer it with yourn. I tole 'im all right, an' he lit out. It was sorter lonesome, an tolerable cold, too, so I gethered up some light u'd an' made me a fire, an' laid down by it an' eat my lunch. Every little while I'd hafter git up an look over my buck, an' feel of 'is horns an' count the shot holes. Purty soon an' old buzzard come a sailin' round an' lit over head, an' went ter eyin' the deer mighty longin. Direckly 'is pardner come along an' jined 'im, an' in a half hour they was a dozen of 'em a' settin' round, a hopein' every minnit I'd leave. I drug a lot of the inards away from the deer apiece, an' come back an set down, an direckly one old feller spread 'is wings an' sailed down, an' purty soon they was all down, an' sich a battlin' of wings, an' fightin' I never seen. They was what some folks calls a Mexican buzzard amongst 'em, an he made the others look wild an' step scatterin'. I got int'rested a watchin' 'em, an' fore I knowed it, it

was 2 er 3 o'clock, an purty soon I hearn a shot way off ter the East. I grabbed my gun an' answered, an' they shot again. I loaded up, an' in a half hour I hearn 'em again not more'n a mile off, an' direckly here they come with the oxen an' wagon. It was Uncle Dick an' Mr. Sam. Pa stayed in camp ter cook supper, an' git things ready ter pull out nex' mornin'.

They had 2 young bucks, Mr. Sam had killed with 'is Winchester, an' 7 turkeys pa had shot. Mr. Sam taken me down an' wallered me, an' said he had a mind ter beat the stuffin' outen me, fer killin the biggest deer on the hunt. We drove on ter camp, an' it was shore rough ridin' over the palmetter roots. Goin' along the hammock jest before we got ter camp about sundown, Mr. Sam pointed inter the swamp, an' there, settin' on some dead live oaks, was a lot of turkeys gone ter roost. He told Uncle Dick ter give 'im 'is gun, an' he'd wait till dark, an' kill some more ter take home, so we drove on an' left 'im. Jest after we got ter camp we hearn 'im fire both barls, one right after the other, an' purty soon here he come, a totein' 3 big old turkeys. We certny had a fine lot of game hung up in camp that night, an' I woulde fool yer. I was mighty proud of my buck, an' so was pa, a heap prouder'n if he'd killed it hisself. We finished up the little buck fer supper, an' pa had saved all the livers an' gizzards from 'is turkeys, an' they was shore fine.

We laid around the fire an' talked over our hunt, an' made it up ter come again an' stay longer nex' winter, fer they all said they never had a better time in their lives, an' I know ding well I never,

It look like all the owls in the country had a hootin' match that night, 'casion of it's bein' our last night in camp, an' jest as we turned in, a blamed old painter holered, off to'rds the big cypress.

"By grannies," pa sez, "there's the mate ter the one we killed yistidd'y, but we'll have ter leave her till nex' year," an' I went ter sleep an' dreamt I killed a painter 10 foot long with my new rifle.

We broke camp soon the nex' morning, an' I shore hated ter leave it. We went back the same way we come, an' there didn't nothin' happen ter tell erbout, 'ceptin' that Mr. Sam killed a doe along the road, the day before we got home, an' pa shot a gobbler with a beard mighty near a foot long.

Ma 'n sister was shore proud ter see us, an' when I showed 'em my big buck, they like ter a smothered me. Mr. Sam give sister the wings of a pink curlew he'd killed, an' took a heap of pains ter save, an' told 'er they was ter fix 'er hat with. Sister turned mighty nigh as pink as the feathers, an' I seen pa wink at ma.

We sent a mess of venison round to our friends, an' that night they all came over, an' set round the fire till late, an' we had ter tell 'em all about it, an' it was most as good bein' on the hunt. Uncle Dick told me ter let me go along an' help him an' pa 'n Mr. Sam drive his beef cattle ter town nex' week, an' I cud pick out my rifle myself. Pa nailed the old buck's horns over the fire place, an when I git my rifle I'm agoin' ter hang it on 'em. An that's all I kin reccomember 'bout our camp hunt, but maybe if we go again nex' year, I'll tell yer what kind of a time I have with my new rifle.

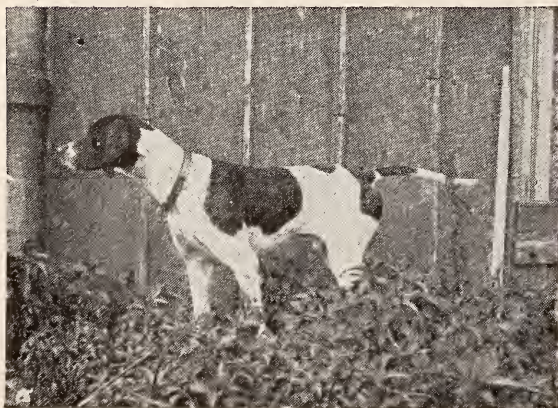

KING CYRO.

#### A ROYAL POINTER.

About a year ago you published in RECREATION 2 photographs of King Cyro, then a puppy. I send you another photograph of the dog, taken in his prime. My physician says I can never go afield again. However, I have had about 48 years of sport, and that ought to be enough to satisfy the ordinary man. The dog is a whirlwind, like his father, King Cyrano, and is for sale at once on a positive guaranty.

F. M. Gilbert, Evansville, Ind.

I can't get along without RECREATION:  
Geo. L. Tate, Livingston, Mont.

## OUR TROPHIES.

G. A. MACK.

Genevieve, only daughter of the Hon. P. D. McDodd, is a witchling brunette, little and lithe. The McDodds are the truffles on the rich brown social crust of our village. For me Genevieve's charms, physical and monetary, are a thousand fold enhanced by her fondness for all sports O. K'd by fashion. She can ride, swim, row, shoot, golf, tennis and bridge whist.

I had met her at small affairs in the neighborhood, and had even been bidden to more formal receptions at Doddhurst, her palatial home; but what I most enjoyed was her companionship afield. She frequently, gun in hand, rambled the woods of her father's estate, accompanied only by her dog. As the McDodd property was not posted, it became my habit to roam thereon in hope of meeting the fair huntress. From our first chance encounter, when I succeeded in finding a wounded ringtail pheasant that had baffled the sagacity of the lady's retrieving dachshund, to our last, when I received with Christian fortitude a charge of shot intended for a heath hen, life seemed Elysian. The trifling *contrtemps* I have mentioned necessarily parted us a while. But what is an ounce of bird shot to a lover? A charge of canister might have cooled my ardor in the grave; Genevieve's No. 8's but stimulated my devotion.

It was a crisp October morn when, almost recovered from saving the heath hen, though still feeling twitchy in spots, I ventured on a walk. The sunshine and the bracing air keyed my ambition to a higher pitch. I determined to do what heretofore I had never dared—ask Miss McDodd to go shooting. Had the distance been greater my courage would surely have failed me. As it was, my agitation was so apparent that the butler eyed me sharply, before, coughing tentatively to warn the footman, he carried my card upstairs. Presently the radiant, nay, iridescent Genevieve appeared.

"I have called, Miss McDodd," I said, "to ask you to go shooting. See how the benignant sun is irradiating the benevolent earth. All is peace and beauty; let's go out and kill something."

And carried away by emotion I burst into unaffected poetry.

"O, wend with me the wildwood glades,  
To coverts where the woodcock drums.  
The while the long billed partridge spades  
The rich dank soil in search of wums;  
Where the coy blue jay lurks discreetly  
And all day long doth sing as sweetly  
As any starlin'.

Come where the dastard coon doth quake  
When chipmunks bellow on his trail;  
Where coils the fearsome garter snake  
With forty buttons on his tail;  
Then wend with me the woodland way  
And these weird creatures we will slay,  
All with your Marlin."

As I proceeded Genevieve's cheeks flushed with excitement, her eyes found added brilliance, her bosom heaved tumultuously. Throwing her petite form into my arms, she exclaimed:

"We will, Montmorency, we will! That is," she added archly, investing with subtle femininity the sportsmanly terms she used, "that is, we will if the bally old gun doesn't jam."

Then bidding me wait, she tripped lightly upstairs. Presently she returned and we were soon following the path to the woods. Genevieve's short skirt, little gaiters and plump calves presented so alluring an *ensemble* that bereaved cows mooded coaxingly. She carried, not her Marlin (that, it seems, was at the plumber's), but a beautiful double barrel 8-bore hammerless repeater, made by Topper, of London. I had my favorite "Good Enough," made in Bruges for W. Moore's Sons.

Never before nor since have I found game in such abundance and variety as on that day. Scarce had we entered the wood when we were aware of the multitude of forest-folk there gathered. There the squirrel crept stealthily through the herbage, on prey intent. There, pop went the aerial weasel from tree to tree. Rabbits ran hither and thither uttering their sharp bark, or swung by their tails from ragweed boughs, contentedly munching chestnuts. Muskrats peeped timidly from their dens in hollow trees, dreading the nighthawk's deadly swoop. Quails chirped merrily in the beech trees. Flocks of ring doves in the beech trees. Flocks of ring doves, in if to drown the plaintive autumnal fugue of the catbird.

Long we paused, spellbound by these revelations of nature. At last we moved onward through darkened dells and tangled brake. We had not sought the sylvan solitude to molest the smaller and unwary game. Far back in deep umbrageous nooks our quarry lurked; for we had that day vowed to slay a chuck. Silently we stole along, intent on surprising our formidable game. Every resource of woodcraft was called in play, alas in vain! I was about suggesting that we return when my companion forestalled me.

"Never will I return without a trophy," she cried. "Let us go on, and I'll bet I make the first kill."

"Done," I said, "a box of gloves against—"

My voice broke, my heart beat wildly. With a stolen glance Genevieve read the secret I so long had hidden. What fervent protestations I should have made I know not, for at that instant she grasped my arm convulsively and whispered, "Look! what is that?" Following the direction indicated by her taper finger I indistinctly saw a dark object in the top of a towering pine.

"A coon, is it not?" asked my fair friend.

Little as I could distinguish of the animal I knew it was not a coon, for, instead of the rat-like tail of that quadruped, I could make out a long furry brush, which might belong to either a fox or a chuck; but being a close observer of the habits of game, I had noticed that foxes are partial to other than coniferous trees. Still, with the true modesty of the earnest nature student, I hesitated to express my opinion. I said nothing. What was more to the purpose, I chivalrously determined to give my companion a killing shot. With that in view, I poured a few ounces of buckshot into my hammerless and hastily rammed them home, intending with that light load to sting the beast into venturing farther out on the branch, thus giving Genevieve a better chance. Not comprehending my intention she laughed joyously when I fired and the creature moved into plain view. With an archly audacious air of triumph she raised and discharged her Topper. A howl of agony followed; a great animal crashed through the branches, fell at our

feet and lay snarling viciously. It was, as I had divined, a woodchuck, and the giant of its species. Fortunately it was too badly wounded to attack us, and a second shot from Genevieve's 8-bore put it humanely out of misery.

As we wended our homeward way through the darkened forest arches Genevieve murmured sweetly: "Don't forget, Montmorency, that I won the gloves."

Falling on my knees, I seized her tiny hand. "But I," I cried passionately, "what do I win?"

"How do I know," she answered coyly. "Papa is croupier for that game. Ask him."

On the first anniversary of our memorable hunt I was seated in the pink drawing room at Doddhurst. On the great woodchuck skin before the blazing hearth Genevieve reclined in an attitude calculated to display to advantage the resources of her *coutouriere*. Beside her, half hidden in the long fleecy fur of the trophy and gurgling sweetly, lay Montmorency, junior. Lifting her eye with pensive air, Genevieve said:

"I have been thinking, dear—"

"Have you?" I cried, with proper surprise.

"Yes, love," she replied. "I have been thinking you ought to write the story of our engagement hunt and"—more softly, while the roses spread from her cheeks o'er all her charming face, and young Montmorency cooed—"and its result."

"And what should I do with it?" I inquired.

"Why. send it to Woodlot and Pasture, the World Behind the Barn, or some other of those journals that just dote on really truly nature stories.

### A PENNSYLVANIA FREAK.

I enclose you photo of freak antlers of a Pennsylvania red deer killed in this county about 8 years ago; 2 curved beams, no branches; the beams are 18 inches long.  
Geo. B. Dechant, Renovo, Pa.



AMATEUR PHOTO BY CLYDE T. DECHANT.

### A CONFESSION.

Mrs. Haterson—Do you think it proper to bow to a man in a club window?

Mrs. Catterson—That depends. It's the only chance I have to recognize my husband.—Harper's Bazar.

There was a man in our town,  
And he was wondrous wise.  
He jumped into a monstrous deal  
That stood on massive lies.

And when he saw the game was up,  
With all his might and main,  
He loaded stock on trusting friends  
And jumped right out again.

—Life.



## FROM THE GAME FIELDS.

The man who quits when he gets enough, with plenty of game still in sight, is a real sportsman.

### A SPORTSMAN'S OBSERVATIONS.

E. E. LEMIEUX.

I laugh heartily when I read my notes of September, 1877, when I was yet in happy boyhood. With a little money and no experience, a friend and I went on a 20 mile canoe trip, with provisions enough to last 4 men a month. How and where we camped, how hard our beds were, how we struggled in culinary art; all was carefully recorded. What little experience I then had of camp life and the possible comforts thereof! Quite naturally, we came back with more experience than cash.

Who can forget one's first achievements? I yet remember the first little fish I caught with thread and bended pin; the first upsetting from my birch bark; the first Indian who got paralyzed at my camp, after stealing the medicine jug; the first duck that fell a victim to my Greener; the first trout, a 2 pounder, whose efforts to regain liberty, though brave and desperate, proved unavailing. These first triumphs are freshened in my mind when I peruse during leisure hours the opening chapter of my records.

There is no limit to the variety of incidents connected with a camper's experience. Often, when on pleasure bound, expecting only fun and merriment, have I come face to face with pathetic incidents. The sight is still fresh to my eyes of that crape on the door of a lonely log cabin, in a distant and almost uninhabited region which I happened to cross; and how can I forget the abandoned grave in that unsettled Northland, which met my gaze on a chilly November afternoon?

While hunting I accidentally discovered this grave, and on my return to camp a trapper with whom I became acquainted explained to me the mystery. In a lake quite near, 2 men while fishing had met a tragic death through their raft breaking away under them. Owing to inadequate means of communication during the first stages of the Canadian Pacific railway construction, these unfortunate laborers had to be buried in the solitude of the wilderness. A mound, a wooden cross, a cedar fence, roughly made, told the sorrowful tale! I have been sadly impressed by such sights on some of my visits to the bush.

At other times, I have made excursions unclouded by scenes of grief, and in which agreeable or even joyful incidents alone happened.

A sportsman may or may not anticipate returning in future seasons to a locality he

has once visited; yet there is no harm in his carefully observing the topography of the country, the roads and distances, modes of communication, postal facilities, and other details connected with the trip. Some day his notes may prove useful in throwing light on a disputed point of an argument, or may even help some friend in quest of information concerning a place to which they propose to make an expedition.

An excellent resource is always to have ready for reference a list of articles that may be required in the line of provisions, clothing, fishing tackle, arms and ammunition. This list may be as minutely descriptive as you see fit to have it; the main object is to be able to make a prompt and judicious selection of what is needed, or likely to be needed, for the contemplated trip. Keep an account of every cent of expenditure, quantities and prices of goods, and whether they were taken from home or obtained at or near the camp location. When ready to go, jot down a few lines in your book which will suffice to prevent errors and save useless work, stating the number of parcels, large or small, in your outfit, and what each parcel contains. It may be that on the way out you will want some special article in your outfit, and having this record you will know where to look for what you require. If this precaution be not taken, perhaps half a dozen bundles will be unpacked before you put your hands on the object of search, the result being confusion and loss of time.

Some campers are more or less embarrassed in deciding what they should take with them on a trip. They are afraid of forgetting some useful accessories, and in consequence take too much of this or of that, thus overburdening themselves with useless stuff and finding themselves minus what is really wanted. This is an important point to consider when long portages are before one. With a little experience and such a list as I have described, it is an easy matter, occupying only a few minutes, to select suitably for the requirements and circumstances of the trip in view. Necessarily, the size of the party, the length of the vacation, the mode of transport and other conditions must be considered. Especially does a prepared list of things necessary come in handy to him who is to see after the provisions.

A good practice also is to note carefully the periods and durations of your trips,

the sport enjoyed, the obstacles and inconveniences met with, the successful means resorted to for obtaining fish and game, who your comrades were and whether or not they proved of the right metal. There may have been one or 2 of that class who are always ready with suggestions of all sorts, but hardly ever attend to their share of the work. Such are a drawback to a harmonious and jolly circle; they would better be left at home.

#### SOME SOUTHERN NEEDS.

The people of the Southern States seem to lack true sporting instincts. This is a hard thing for a Southerner to say, but I can show the justice of it. I am Southern, almost to a prejudice, so when I say the South needs true sportsmen, I am lamenting, not scolding.

To begin with the scattered gun clubs, have they any positive laws? Do they defend the game? Do they try to induce better legislation? Not often. I know of cases in which clubs paid for an option on land, baited the land, and then permitted the members to slaughter migratory birds. This is as bad as trapping. To systematically feed doves and then take advantage of their natural gentleness and trust is little short of murder. Doves are out of the list of game birds any way.

Another proof the lack of interest among Southern sportsmen is the lack of unity. Let the clubs send delegates to the meetings of the L. A. S. This will give them ideas of how to control the situation. It will show how deplorable the actual condition is. The various clubs are at odds with one another; only a select few members belong to each, and thus we have no power to influence our legislators. We have good laws, but they are not enforced. We need unity to induce our lawmakers to give better laws, to supersede the antebellum laws that are nearly forgotten. The L. A. S. has this unity. It is an American association, and the South can enter into it as freely as her men enter American markets. The South is as truly American as the North. Why should we see our game go unprotected, while our Northern brothers are doing so much?

I am not a sportsman myself, but I have spent 15 years in observing conditions. I am a devoted lover of nature, and have had opportunities of seeing what exists. Game is rapidly decreasing, fishes are harder to find. As long as pot hunters and men who dynamite fishes go unpunished diminution will continue. Action is required at once.

We need some new laws, but still more we need enforcement of the laws. Most of the Southern States have excellent laws, made by our fathers, but they are not enforced. The negroes know that it is illegal

to trap quails or to dynamite fishes, but they realize the indifference of the authorities and seldom hesitate to break the laws. Our Legislatures claim that more important matters come first; our business men claim that their cotton, corn or mercantile business comes first in their consideration; but no excuse can cover this inaction. Sheriffs are expected to arrest felons; officers are required to enforce the laws. If the laws say not to kill certain animals in certain seasons, he who does it is a felon, and punishable under the law. The officer who winks at this is inefficient. Remove him.

Not important! Can any man look himself in the face and say this? Our naturalists tell us how birds and animals act as scavengers on filth and on injurious insects. Have our Southern men and women forgotten that refinement which once characterized them? No country is complete without its birds, animals and fishes. When we see only tame fowls, cattle and sheep, pet fishes or those raised like stock, we have indeed lost the spice and beauty that once made America famous. Give us laws; protect our game birds, animals and fishes. Do not say "tomorrow," but act today.

Who is to awaken the interest of the South? Our master minds are eager to develop the country in a financial way; are too busy to look down and see the game being destroyed. Our lumbermen are heedless, our farmers careless, our merchants indifferent, our mechanics too busy building towns, and everything seems to say, "Business today, game laws tomorrow." Tomorrow will be too late.

T. H. W., Kyle, W. Va.

Your statement of the situation in the South regarding game protection is most interesting. I am surprised to find, on examining our records, that you are not a member of the L. A. S. It is strange that so many friends of game protection all over the country urge this League to protect their game, and yet decline to put up \$1 a year each to aid in its work. A man who feels the interest you evidently do in the cause of game protection, should not only be a member of the League himself, but he should be working diligently among his friends and neighbors to get them to join. I am always glad to use my influence and that of the League in bringing about needed reforms, and we have accomplished more in this line than any other organization ever did. We could, however, have done 10 times as much in the time we have been at work if all the sportsmen in the country had done their duty toward us. We should have had 100,000 members now, instead of 9,000 as we have. Are you not willing to do some missionary work among your neighbors?—EDITOR.

## NEAF APGAR PUNISHED.

The following correspondence is mighty interesting reading:

Mr. Arthur F. Rice, Sec'y L. A. S.,  
New York.

Dear Sir: Neaf Apgar, who is, I think, a resident of New Jersey, was here shooting pheasants last fall without a license. He claimed to be a resident of Philadelphia. He represents the Peters Shell Company, and is a crack trap shooter. I understand he is to be in Williamsport soon, to attend a trap shoot. I wish you would look him up. If he is not a resident of this State, he ought to be prosecuted.

G. H. Simmons, Westfield, Pa.

Dr. Joseph Kalbfus,  
Sec'y State Game Commission,  
Harrisburg, Pa.

Dear Sir: I hand you herewith a letter from Mr. G. H. Simmons, Westfield, Pa. I have known, in a general way, of Apgar's living in New Jersey for several years past. There is not the least probability that he has changed his legal residence to Pennsylvania. I wish, therefore, you could arrange to attend the shoot at Williamsport and investigate this matter. Apgar is a professional trap shooter, and is paid a big salary to attend all the shoots. While posing as a sportsman and a representative of an ammunition factory it seems he sneaks into your State, dodges the \$10 license, and steals a lot of your birds. I trust you may be able to soak him. Kindly let me know the result of your effort.

G. O. Shields.

Mr. Neaf Apgar,  
Plainfield, N. J.

Dear Sir: I understand that you spent some days hunting in Pennsylvania last fall; that you did not take out a license; and that you stated to certain persons where you hunted that you lived in Philadelphia. Will you kindly tell me whether this report is true?

G. O. Shields.

Philadelphia, Pa.

Mr. G. O. Shields,  
New York.

Dear Sir: I was hunting in Pennsylvania last fall, and hope I did not break any game laws. I do not think I did. I am living here yet, and shall be until the Company changes my territory. Also, I have a piece of property in the State.

I should not object to paying a license if I thought it necessary, as I am a believer in the law. You know I could not afford to break any laws and would not if I knew it.

The letter you sent to Plainfield was forwarded to me here.

Neaf Apgar, Frankford, Pa.

Mr. G. O. Shields,  
New York.

Dear Sir: I am obliged to you for your communication of the 15th, and will see that Neaf Apgar either owns real estate in this State or pays the license as required.

Joseph Kalbfus.

Mr. G. O. Shields,  
New York.

Dear Sir: The Commission at once took up the matter of Neaf Apgar, and followed it carefully up to Friday last, when we arrested Mr. Apgar, at Williamsport, on the charge of hunting in this State without having secured the license required by law. Mr. Apgar confessed to having hunted in this State, as claimed, for 4 days, admitted that he was not a resident of the State, and that he did not own land in the State. He claimed he did not kill one-half of the birds we had him charged with, and that he did not take any out of the State. He admitted that he had done wrong, and was sorry for it; and he paid me \$100, the full penalty for 4 days' shooting in the State without having secured the license, and \$50 to cover costs, the balance, if any, to be returned to him.

I feel that this man has been fully punished for his offense and that the effect will be exceedingly beneficial to the cause of game protection in this State. We thank you and the L. A. S. for the help you have given us.

Joseph Kalbfus.

## A MODEST BAG.

The day before last spring my brother George and I had set as the time when we would have a hunt on English lake, distant from our home about 50 miles. The morning of the appointed day we rolled out at 3 o'clock, got a bite to eat, hitched the little bay mare to the buggy, loaded in our guns, hunting coats, boots, and 16 boxes of shells each and away we went. In 15 minutes and 59 seconds we were driving up to a friend's house on the banks of the lake.

We soon had the mare stabled and our hunting togs on. Day was breaking, so we hurried to a boat in order that we might secure a good place before the morning flight of ducks began. We had hardly pushed off, when a tremendous flock of small birds arose from an island about 20 rods in front of us. George tore loose at them with his old 4-bore duck gun and I could see holes appear in the flock; but

the birds flew right toward us. George shouted,

"Shoot, shoot, you blanked idiot! Don't you see the things are mosquitoes?"

Sure enough, they were, and as big as robins. We both had 4-bore magazine shot guns, and the magazine of each held 16 shells. George's shells were loaded with  $\frac{1}{2}$  pound smokeless powder and 98 No. 5 buckshot to the shell. I used  $\frac{5}{8}$  pound of smokeless powder to 105 No. 8 buckshot. We emptied our muskets at the birds, and then began to shoot at them with our 10-bore pistols. By that time the mosquitoes were well thinned out and the rest of them flew away. We then found they had fallen so thickly about the boat that we were entirely hemmed in. We had to portage the boat over the bank of flesh into clear water.

We soon settled in a good blind, and George had pointed out an approaching flock of ducks when I felt a severe pain in my left arm. I looked down, and there was a mosquito with his proboscis clear through the thick part of my arm. I finished him mighty quick. I then turned to the ducks again. They were nearly close enough to shoot at, when a bunch of the mosquitoes darted up from the grass and tackled them. It was a curious sight. The poor ducks tried to get away, but it was no use. A mosquito would dash at a duck and down the duck would go, dead, pierced to some vital point by the mosquito's proboscis.

Soon the sun rose, and we had good shooting. About 7 o'clock we saw 3 geese approaching. George killed 17 of them at one shot from his toothbrush and I knocked over the other 6 with 2 shots from a bottle of soda water I had in my pocket.

About noon, when my gun happened to be empty, I attempted to fire my husking peg at a flock of ducks, but it failed to go, and I found the hair spring was broken. This I felt to be a great loss, as it had been a faithful timekeeper 17 years.

After a heavy afternoon's shooting, we got home about 7.30 p. m. We went into the kitchen and unloaded the game from our coat pockets. George had 843 ducks, 17 geese, 46 wild turkeys, 108 mudhens, 93 pelicans and one rabbit. The rabbit he killed accidentally, as it was with some turtles. I had 711 ducks, 6 geese, 3 wild turkeys, 215 mudhens, 48 pelicans, 28 ptarmigans and one condor, which I mistook for a chicken hawk. It was so high that it spoiled before reaching the ground. I had neglected to soak my shot in salt water before leaving the sea shore. We were proud of our showing, and I doubt if anybody else could take the 22 caliber single shot rifles we used and do better.

Van T. Grover, Stillwell, Md.

#### GAME IN THE PHILIPPINES.

To him whose chief delight is hunting, the Philippine islands are a paradise. We have game of various kinds in abundance, but now we must follow RECREATION and protect it or the conditions will be like those in the States. The people here kill deer, ducks, etc., all the year round. We ought to have a law prohibiting the killing of deer and other game, except during certain months. There is a gun club in Manila but instead of trying to protect the game, the members are destroying it. Among the common game may be mentioned, deer, wild boars, ducks of several species, wild pigeons, jacksnipe, doves, wild chickens, mountain quails, etc. Deer are numerous in the mountains and are much hunted by natives, Americans and foreigners at all seasons. The native manner of catching deer is as follows: The trail is followed to where it branches into 2 or 3 paths, and where the natives stretch a rope net. The deer are then chased by natives and dogs until they run into the net. In this way most of the Americans hunt, by hiring natives and their dogs. The Americans are stationed along the trail by the natives, and the deer gets shot, or runs into the net. When the men return to the towns they brag of the good luck they had.

Boars are hunted in a similar manner, and speared with sharp instruments fastened to bamboo poles. Wild chickens are abundant in the foothills, but are hard to get on account of the dense thicket, and underbrush. Ducks abound in all lake regions, rice fields, etc.

Owing to cholera in Manila, we were unable to have fresh meat shipped us here, so I decided to go to a small lake near Bautista and see if the fresh meat was not floating around on the surface waiting to be taken to the band mess. Early one morning with haversack filled with ammunition, canteen with distilled water, lunch and my Winchester shot gun. I started on the train for Bautista. Our trains make about 15 miles an hour, and in an hour's time I reached my destination. At the lake I hired a bamboo raft and an *hombre*. The raft was 2 feet wide and 12 feet long. The *hombre* took his seat in the rear with a big bamboo pole and I took the front end. We had gone only a few yards when the raft upset. I got on again, discharged the *hombre* and hired a better one. On account of the noise I made, a big bunch of ducks rose from the water and went toward the other end of the lake. I pushed on in pursuit, and saw them in the middle of the lake. At about 80 yards, they got up, passed me and made for the other end of the lake. They circled back again, until the air was full of

ducks. Natives were on the bank watching me. Often I had to dip the gun in the water to cool the barrel in order to handle it. In an hour I was surprised myself, at the number of ducks the *hombre* had piled on the raft. I told him to push for the shore. I had 64 ducks, all I wanted. On the way down I could have killed as many more but did not fire a shot. When I got to Dagupan with my supply the band had fresh meat the next day in spite of the cholera regulations.

Corp. John N. Bryan, Dagupan, P. I.

#### MR. POWELL REPLIES.

On my return from Alaska I was amused to find, in reading my back numbers of RECREATION, that the boys had jumped on me and made me out a liar. G. H. Tremper misrepresented my statements. He says I killed 3 grizzlies. The article referred to did not say I killed 3. He says I killed them at 200 yards, which is also a falsehood. He says my statement that a wounded grizzly gave chase at 145 yards is the first case ever known. It might have been to G. H. Tremper; but I hope to prove the contrary by affidavits of Copper river people, when I return.

The weight of the bear was a guess, and included the skin; but when Mr. Tremper says there is no authentic record of a bear weighing 1,200 pounds gross he is mistaken. A bear is seldom killed where it can be weighed. Bears have often been killed that have measured more than 11 feet, which I expect to prove by affidavits of reliable men. Mr. Tremper says it is to be regretted that I did not explain how I kept the meat from spoiling during 3 weeks of hot weather. The meat was delivered to the miners of Slate Creek within 3 days of the time it was killed, which I can prove by men who ate of the meat and can testify to the approximate weight of the bear.

I did not suppose my statement would cause so much unfair comment. To kill a caribou in 3 shots, at 200 yards, when he was in water and the range could be ascertained, was not an unusual thing to do, but I considered it a lucky shot.

I intend to get affidavits of bears giving chase, their size in some parts of Alaska, and of 2 men who saw a caribou killed with a pistol as far as I killed that one. I am not in the habit of betting on my shooting, as I do not consider myself an extra pistol shot. Others, no doubt, can beat me at that; but as Mr. Tremper insinuates that I can not hit a barrel with a shot gun, I will again attempt to hit the size of a caribou at a distance of 200 yards at 3 trials. I should like to hear from Mr. Tremper at Valdez if he is willing to cover \$1,000 that I can not hit a target 5 feet square with a pistol at 200 yards.

I expect to deposit the money in the Valdez bank for that purpose, and will also notify RECREATION when it is so placed. Meantime I enclose sworn statement of F. R. Launtz:

State of Washington,  
County of King.—SS.

F. R. Launtz, being duly sworn, deposes and says that he did see A. M. Powell shoot and kill a caribou with a pistol at a distance, to the best of his belief, of more than 200 yards; that he did freely and voluntarily sign a duplicate letter to the editor of a magazine known as RECREATION, wherein he stated the said circumstance.

H. Reinhart,  
Notary Public.

Seattle, Wash., May 26, 1903.

I have no more time to give this matter at present.

A. M. Powell, Santa Maria, Cal.

#### FOREIGN SWINE.

In connection with the coal strike, one point was not brought out, which, although of no great economic importance, is of interest to sportsmen. I refer to the wanton destruction of our insectivorous birds, our game and our fishes. Sportsmen who tramp the woods hereabout for the pleasure of it, or with the camera during the warmer months, never fail to see men, mostly Slavs, Italians, or Poles, with guns, hunting anything that flies, from the smallest flycatcher to the flicker or robin, and from the baby quail to the respectable mother grouse who is hustling for her family. It is a crafty grouse or quail which can hide her nest so well that it can not be found by one of the mongrel dogs which accompany the hunter. If the eggs are too near the hatching time to suit the taste of the masters, the dogs are not so fastidious. Several dogs, of yellow breed crossed with hound or anything else, a stout stick or a bag, and one or 2 ferrets complete the outfit. The rabbit seldom escapes, and there is no gun report to attract attention. I am sorry to say the use of ferrets is not wholly confined to this class of hunters.

The method of fishing is even more destructive. These men, accustomed to the use of dynamite, know just how to handle it to the greatest advantage in the pool of a trout stream or a pond, and it is not surprising that most of the streams within a day's walk of the mines are depopulated.

Another method, which is not so thorough, but which cleans out the smaller fishes, is the use of a net built like a large Y, with which everything under the edge of an overhanging bank can be scooped out. Pickerel or any other fishes which lie along the bank in shallow water can be

sufficiently stunned with a shot gun to enable the meat hunter to catch them.

There are laws against all this, and the Luzerne County Sportsman Association tries to have them enforced in this locality. The chief trouble is to get evidence which will convict, and to raise the necessary funds for prosecution and the payment of wardens. In May, 1902, one Italian was convicted of dynamiting a stream, but 15 others got away through insufficient evidence. A number of men were convicted last summer and early fall for killing during the closed season and for destroying insectivorous birds, but many more escaped detection. What we need is a more general recognition of the conditions and a warmer interest among those not classed as sportsmen.

D. A. H., Wilkes-Barre, Pa.

#### A UNIQUE DEVICE.

723,382.—Combined Cane and Camp Stool. John Halin, Kansas City, Mo., assignor of one-fourth to Jonas A. Nelson, Kansas City, Mo. Filed April 22, 1902. Serial No. 104,173. (No model.)

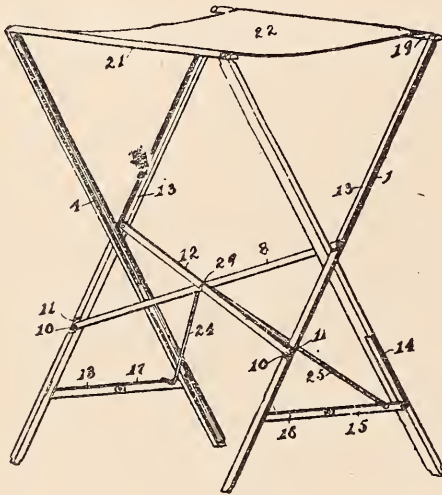

Claim.—1. A camp stool comprising 2 pairs of legs, the legs of each pair being pivoted together, 2 seat-supporting members connected with the upper ends of opposite pairs, but detachable therefrom, a seat connecting the 2 said members, braces extending transversely from one pair of legs to the other, each of said braces being pivotally connected to the leg of one pair and detachably connected with the leg of the other pair, folding braces connecting the lower ends of each pair of legs, and a supplemental brace connecting the folding braces with the said transverse braces.

2. Each leg being provided with a recess, 2 detachable seat-supporting members connected with the upper ends of opposite pairs, a seat connecting the 2 said members, 2 transverse braces pivoted respectively to the legs of opposite pairs in the recesses

provided therein and detachably connected at their free ends to the opposite legs, 2 folding braces comprising each 2 members hinged together and pivotally connected at their free ends to the legs forming one pair, the said folding braces being adapted when the legs are folded, to be disposed within the said recesses provided therefor in the legs.

#### A PLEA FOR THE BIRD DOG.

There appears a tendency among certain readers of RECREATION to attribute the crimes of the game hogs to their equipment. Thus one man condemns the pump gun and another the use of trained dogs. Is this attitude of mind that of sportsmen?

Suppose George Washington had claimed it was the fault of the hatchet that the cherry tree was cut down, or pleaded that if he had had only a club instead of a hatchet all his efforts could not have resulted in a fallen tree. Would not that have been very different from his manly admission of his fault?

How often we hear of a man ruined by drink. Was it drink or hoggish propensities that caused his ruin?

The man who takes a primitive weapon and limits his bag of game only by his limited ability to kill is at heart a game hog; while the man who, with the most approved weapons, scorns to take undue advantage, stops killing when he has enough and yet has the power and opportunity to increase his score, is a gentleman and a sportsman.

When I must decide between hunting without a dog and hunting without a gun, it will be the gun that will remain at home. Some of my most enjoyable hunts have been with dog and camera; yet I am passionately fond of shooting. The magnificent running of the dogs, their intelligent obedience, their delight in the sport, their appreciation of praise, their unflinching love and faith, all are sources of keen delight to a true sportsman. Shall I give up this joy and sneak through the woods with my nerves tense in order that I may shoot quickly and be sure to kill? The true sportsman with his dogs thinks of killing only at the instant when it becomes necessary. Without the dogs he will surely bring home an empty bag unless he thinks constantly of his gun and a possible victim. I write from considerable experience of both kinds of hunting.

Let us face the question honestly. A hog is a hog, no matter how equipped, and a gentleman is no less a gentleman because he uses an effective weapon and loves one of God's noblest creatures.

R. R. Raymond, Captain Corps of Engineers, U. S. A.

## HUNTS WITH HIS CAMERA.

I have often noticed that you roast game hogs for killing game and taking a great number of fish. As I hunt and fish only with a camera, I am with you; you can not roast them enough. I hope the L. A. S. will do all in its power to have bills passed to prohibit shooting and fishing, so that lovers of nature can go into the woods, hear the birds sing and see them without having them fly away at the sound of voices. I am fond of walking in the woods and of boating, but can see no pleasure in tramping all day in rain and snow for the sake of killing game. There is more pleasure in watching birds than in shooting them. In the West I have seen deer and other game and have frightened them so that hunters could not get a shot at them except for trailing. I think it was one of the best things I ever did for the game. In Florida I have seen fish 6 to 30 inches long, have hunted turtles and watched the Indians hunt alligators and enjoyed it, but could see no sport in taking more than enough for a meal. There is no better sport than a long tramp in the country with the camera, going to some farmhouse for a good dinner of fresh vegetables, salt pork, fresh bread and milk.

One game hog is the hard working man who can not go hunting when he would like to; so on Thanksgiving day he takes his gun and 2 or 3 dogs, and, be it wet or dry, shoots at anything he sees, not because he wants it for himself, but to get all he can to show his friends. Of course he must have a flask of whiskey to keep his courage up. He starts home at dark, wet muddy and drunk. If he has any game he is foolish enough to show it. As a rule these men are foreigners and don't care much for the feelings of others, but are not so much to be blamed as pitied. Still they should be taught, as otherwise they never will know better.

A Reader, Northampton, Mass.

## A VACATION TRIP.

Last season a friend suggested that we go to Maine for a hunting trip. We finally decided on North Paris. Three of us started from Boston the middle of November, with our hopes high and our trunks filled with ammunition. We took the boat to Portland and then the Grand Trunk to West Paris, where we arrived about 9.30 a. m. Our host met us with a team and gave us a pleasant ride of about 3 miles through as picturesque scenery as is found in that State. There were mountains all around, dotted here and there with lakes and brooks, and the farm houses looked inviting and homelike.

The next day we started out to see the country. There was a lake near, contain-

ing many fish, waiting to be caught, and we saw a number of streams containing brook trout. The country was alive with grouse and rabbits, and deer were plentiful, 2 or 3 being killed nearly every day by the party, within 12 miles of the house. Our host had log camps back in the woods where one could stay 2 or 3 days at a time, in the heart of the wildest nature.

After we had been at the lake about 2 weeks the snow came and then we started for the deer. When we wanted a few hours' sport near, we took the dogs and went into the swamp for rabbits, which gave us lots of fun for little exertion. After a day's tramp, it was good to sit down to the appetizing dinner which our hostess always had for us, whether early or late, and then to smoke, discuss the day's sport and the chance of more the following day.

When we had to say good-bye we left with regret to return to our work; but we were improved in health by the outdoor exercise and the excellent fare, and we had many pleasant memories.

W. E. Bollsdon, Roslindale, Mass.

## IN ONE ROUND.

Some years ago I was in camp 25 or 50 miles Northeast of Flathead lake, in Northwestern Montana, with only a cook and a little Scotch terrier for company. One Sunday morning I heard the cook preparing breakfast. He had not called me. Then suddenly the horses began to snort and Fuzzy, the dog, took after something at a great rate. The horses broke and bolted down the rocky glade. I got my tools ready, but could see nothing, so I called the dog back, and then went after my favorite horse. A bear had unmistakably called on us. My only weapons were a Colts' 45 and a heavy W. W. Greener 32 inch, 10 gauge, 11 pound gun. I had 12 Berdan shells, with 5½ drachms of powder and 24 No. 8 buckshot in each.

I tied Fuzzy to a tree and took up the bear's trail. The longer I followed, the closer we came together, and by running down hill and making all time count, after 8 or 9 miles I heard the grizzly turning rock and making as much fuss as a pair of yoked oxen. I got close, on level ground, then said,

"Hi, there."

The bear stood up, full height, looked me over, and I had to shoot. I hit the broad neck, under the under jaw, so of course I won the belt; but I took the advantage, for I did not shake hands or choose a referee. Of course he had me on weight, was more scientific, and was better built for a scrapper in the ring. He was my last antagonist in the ring.

I rolled up the skin and claws, but could

not carry them, so I had to get the team to take them to camp.

G. W. Davidson, Mt. Pulaski, Ill.

#### GAME NOTES.

One morning in October I started for the Bitter Root, reaching Hamilton about 8 p. m. From there I took the stage for Wiles Springs.

While awaiting dinner a farmer and the bartender got into an argument about an antiquated 45-90 rifle, and adjourned to the backdoor to settle it. They used a knot in the ice house for a target. The first shot was about 14 inches too high, the next about 8 inches, and the third a foot to one side. The ice house was 15 feet distant. I noticed a solemn silence about the accuracy of that particular rifle.

Next morning at Wiles Springs I girded on my cartridge belt, took my 44 caliber rim fire Henry rifle and started. After climbing over hills for 2 hours I shot a pine squirrel to prove that the rifle was still accurate. Just as I got back old Doc Wiles came up with a string of fish and an invitation to supper.

The second evening I traded my little Marble axe for a large deer head and started home. I had to go to work again. The natives told me deer were scarce, but there are all kinds of small game in that country.

D. R. C. T., Anaconda, Mont.

One night last October we decided to have an old fashioned coon hunt. The day had been damp and rainy and just the right sort for the purpose. The moon was bright when we took our hounds to a tamarack swamp and liberated them. Old Fox, the leader, with Nig, Tommy and 7 more black and tan hounds bringing up the rear, soon struck the trail of an old coon that had evidently passed early in the evening. After an hour's chase the coon treed in an old snag 30 feet high, giving us a hard chase through the swamp and over windfalls. When we cut down the tree 4 coons fell out and started in as many directions, but were caught and killed by the hounds. One of these coons weighed 38 pounds. This did not satisfy Fox, for he started out again, and in a few minutes the whole pack was streaming by us, making a racket like the song of a calliope. They treed the coon in a bunch of tamarack 40 rods away, and there we added 2 more coons to our already heavy load.

P. R. K., Avon, Minn.

A notice in the last issue of RECREATION related to hounding deer. There is one citizen in this neighborhood who does not tolerate this practice. This gentleman is Geo. W. Blackwood, of Luzerne. About

a week ago 2 hounds chased a young buck on to the ice of the Hudson river at Luzerne, and Mr. Blackwood at once killed the hounds and rescued the buck. Mr. Blackwood should be commended for his act. If other people would treat the hounding practice in the same way they would aid greatly in the preservation of the noblest of our game animals. Mr. Blackwood will ask permission of the game warden to keep the buck and domesticate him.

Morgan H. Fish, Glens Falls, N. Y.

Mr. Blackwood is all right, and I wish every man in the State who sees or hears dogs running a deer would deal with them as Mr. Blackwood did with those hounds.—EDITOR.

I am an old timer and hunt for sport more than for game. I am in a country where squirrels and quails are more than plentiful, where duck shooting is excellent in season, where there are a sprinkling of deer, turkeys and prairie chickens, and a class of people who know no game law. Fawns are shot from the doe's side, quails are shot from posts and nests, squirrels are shot with their young, and there is no way to stop it. We are under the Arkansas law, but have to look to Federal officers for justice, and we look in vain. I have been here nearly 2 years and have argued and preached against the indiscriminate slaughter of game and against using nets and dynamite in the streams. The only good I have done is in regard to quail shooting; I have a few of the bristlebacks won over on that point. I fear by the time we get legislation to protect our game we shall have none to protect.

Jack, Guthrie, I. T.

726,277.—Goose Call. David S. Fuller, Chicago, Ill., assignor of one-half to Watts De Golyer, Chicago, Ill. Filed January 2, 1903. Serial No. 137,503.

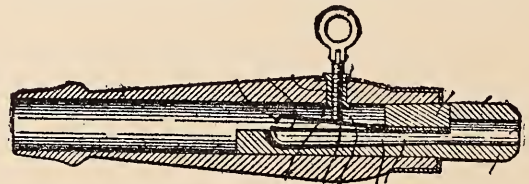

Claim.—1. A goose call or the like comprising in combination a mouthpiece member consisting of a sleeve, a radially adjustable set screw therein, and a telescopic call member adapted to be inserted into one end of said mouthpiece member, reeds carried by said call member and projecting into the path of said set screw, and a wedge interposed between said mouthpiece member and said call member to secure the latter removably in place.



I have been a reader of RECREATION the past 3 years, and especially enjoy the game notes. I like also your way of handling game hogs. The harder these things are dealt with the quicker will game and fishes increase.

Rabbits and quails were plentiful here last fall; grouse were scarce and those few that had escaped the pot hunters of the previous fall were careful not to show their tail feathers this fall.

There still remain a few game and fish hogs in this State, but they are being reformed by the persistent efforts of our better class of sportsmen, most of whom see that now if ever is the time to save what game and fishes remain. With the aid of RECREATION we hope to gain our end.

L. A. S. 3,230, Providence, R. I.

Dell Andrews, of Greenville, Pa., has broken the record for duck shooting at Conneaut lake so far this season. Thursday he shot 164 ducks and one loon, and yesterday he resumed the killing.—Pennsylvania paper.

I did kill 164 ducks April 23, 1903.

Dell Andrews, Greenville, Pa.

Which simply proves that you either can not read or are too lazy to read. If you would read a few issues of RECREATION and learn how generally such slaughter as this is condemned, it is safe to say you would not be guilty of it. Possibly you have no regard for the opinions of others, but it is more likely that you are grossly and densely ignorant of the subject of true sportsmanship. I advise you to read RECREATION a few months and you will know a lot more than you do now. Meantime, your number in the game hog pen is 889.—EDITOR.

I always buy RECREATION when possible, and am especially interested in the gun and ammunition department. I am also much interested in the preservation of game. Being a hunter myself, I do all I can for the cause, but it is of little use, as this region is famous for its game hogs and disregard of all game and fish laws. I live 6 miles from Northville, just over the Hamilton county line, in the edge of the most lawless region of Hamilton county, famed for its lawlessness. The inhabitants of this section openly boast of killing deer in the winter, and it is not uncommon to see 5 to 10 deer brought boldly in. Hounding and jacking are carried on openly. The deputy game warden is one of the worst game law violators in the country.

M. S. Brown, Northville, N. Y.

It has been a great surprise to me to read in RECREATION of the large number of brutal and inhuman exhibitions, known as side

hunts, that are held in different parts of this country. The people in this section of the Keystone State are not so degraded as to commit such barbarous acts, and I never heard of such a thing as a side hunt until reading of it in your magazine. Of course the game laws are violated here, but, thanks to the strenuous efforts of the L. A. S. and other protective organizations, the violations are becoming fewer every year. Nearly everyone is in favor of protecting game, and many sportsmen are working hard toward that end.

Harry P. Hays, Hollidaysburg, Pa.

In April RECREATION you published an account of my hunting in Northern Michigan. I received many letters about the article from different people, among them one letter from a gentleman in Ohio or Indiana, asking for information. In some way I lost the letter and have been unable to answer it. Will you please print this statement in RECREATION so that the writer will be glad to answer it.

J. J. McCormick, Ann Arbor, Mich.  
714 Fuller avenue.

Plenty of turkeys are reported 5 or 10 miles East of here, and many quails near. This country will be settled before many years, and turkeys and deer will be gone, except in the rough country between here and Arkansas, where they will last a little longer.

J. E. Jones, Atoka, I. T.

I have been a reader of RECREATION for years. I heartily agree with your view in regard to game protection. I remember when game was plentiful here; now it is scarce indeed. I wish you God speed in your roasting of game and fish hogs.

Van F. Grover, Stillwell, Ind.

I enclose a leg band marked "G. A., 6827," taken by Frank Valencourt from the partly decomposed body of a carrier pigeon found on the railroad track at this place, June 14, '03.

Bert Lynch, East Pepperell, Mass.

Are you interested in hunting, fishing, natural history, game protection or amateur photography? If so you should be a subscriber to RECREATION. Send in your \$1 now. The stories in RECREATION are the actual experiences and observations of men who live out of doors, who shoot, fish, photograph and study nature; and they depict outdoor life as it is. If you wish to be one of them subscribe for RECREATION,

## FISH AND FISHING.

### ALMANAC FOR SALT WATER FISHERMEN.

The following will be found accurate and valuable for the vicinity of New York City:

Kingfish—Barb, Sea-Mink, Whiting. June to September. Haunts: The surf and deep channels of strong tide streams. Baits: Blood worms, shedder crabs and beach crustaceans. Time and tide: Flood, early morning.

Plaice—Fluke, Turbot, Flounder. May 15 to November 30. Haunts: The surf, mouth of tidal streams. Baits: Shedder crabs, killi-fish, sand laut. Time and tide: Ebb, daytime exclusively.

Spanish mackerel—Haunts: The open sea, July to September. Baits: Menhaden, trolling—metal and cedar squids.

Striped Bass—Rock Fish, Green Head. April to November. Haunts: The surf, bays, estuaries and tidal streams. Baits: Blood worms, shedder crabs, Calico crabs, small eels, menhaden. Time and tide. Night, half flood to flood, to half ebb.

The Drums, Red and Black. June to November. Haunts: The surf and mouths of large bays. Bait: Skinner crab. Time and tide: Day, flood.

Blackfish—Tautog, April to November. Haunts: Surf, vicinity of piling and old wrecks in bays. Baits: Sand worm, blood worm, shedder crabs, clams. Time and tide: Daytime, flood.

Lafayette—Spot, Goody, Cape May Goody. August to October. Haunts: Channels of tidal streams. Baits: Shedder crabs, sand worms, clams. Time and Tide: Day and night flood.

Croaker—July to October. Haunts: Deep channels of bays. Baits: Shedder crabs, mussels. Time and tide: Day, flood.

Snapper—Young of Blue Fish. August to November. Haunts: Rivers and all tide ways. Baits: Spearing and menhaden; trolling pearl squid. Time and tide: Day, all tides.

Sheepshead—June to October. Haunts: Surf and bays, vicinity of old wrecks. Baits: Clams, mussels, shedder crabs. Time and tide: Day, flood only.

New England Whiting—Winter Weak-fish, Frost-fish. November to May. Haunts: The surf. Baits: Sand laut, spearing. Time and tide: Night, flood.

Hake—Ling. October to June. Haunts: Open sea surf, large bays. Baits: Clams, mussels, fish. Time and tide: Day and night, flood.

Weak-fish—Squeteague, Squit. June to October. Haunts: Surf, all tideways. Baits: Shedder crabs, surf mullet, menhaden, ledge mussels, sand laut, shrimp. Time and tide: Day and night, flood preferred.

Blue Fish—Horse Hackerel. June to November 1st. Haunts: Surf, open sea and large bays. Baits: Menhaden, surf mullet and trolling squid. Time and tide: Daytime; not affected by tides.

### FLY FISHING FOR BLACK BASS.

What constitutes a sportsmanlike method of angling? The method demands the maximum of skill, but offers the minimum of certainty of success. The experience and skill of the angler are pitted against the instinct for self-preservation and the fighting qualities of the game fish. All "dead sure" plans for taking any game are unsportsmanlike. What real sportsman would wish to land every fish hooked? What real sportsman would wish to hook a fish at every cast, or even at every 20th cast? Unfortunately, many who call themselves sportsmen measure sportsmanship by the number of fish caught or the game bagged;

but these are not genuine sportsmen. All should condemn them, and, if possible, reform them. I pity the game and fish hogs, but it is a pity that looks hopefully toward their reformation and proper training of their ethical natures; or failing in that, a desire to see them hobbled, muzzled, penned or whatever will relieve the public from the most thoughtless, if not the most pernicious, of the *genus homo*.

A method of fly fishing practiced by a few of our expert bass anglers in some of the lakes in the Middle West is with a 2-handed rod 15 to 16 feet in length, and that, too, a natural growth of Japanese bamboo. Now do not get excited, brother sportsmen, but bear with me to the end and then you may say what you please.

First select the rod; not so simple a matter as might be supposed. Many a bundle of 50 rods have I examined carefully without finding one fit for the delicate work expected to the first class rod. No rod is made, or probably can be made, suitable for this style of fly casting. This rod must be of the right kind of timber. It must be the right size and the prescribed weight;  $\frac{3}{4}$  of an inch in diameter at the butt, with cylindrical internodes, and perfect taper to the tip. Above all, it must have perfect balance and resiliency.

Then come the dressing and mounting of the rod, truly a work of love. First, rasp down the joints, from the butt to the middle, nearly to the diameter of the internodes; from the middle to the tip, to a less extent; near the tip scarcely at all. Sandpaper freely until all joints are perfectly smooth; then oil the entire rod thoroughly. The oil should be rubbed in by the naked hand a number of times a few days apart. Next comes the butt grip. An old style cork bicycle grip securely fastened by means of shellac or waterproof glue makes an excellent butt grip. Five or 6 inches above the grip place a Brower's reel seat, wound on the rod with waxed ends like those used by harness makers. Five German silver trumpet guides should be wound on the rod at the proper places with the same material. Great care must be taken to place the reel seat and guides on the proper side of the rod, as both the balance and the strength of the rod will be thus greatly improved.

Metal tips well suited to this style of rod are not found on the market. Longer tips being desirable, the ordinary 3-ring tip is lengthened by soldering one to 2 inches of suitable tubing to the tip. This tip is usually drawn off and placed in the tackle box while the rod is not in use.

Such a rod, if properly cared for, will

stand hard service several years. One not acquainted with such a rod will be surprised at its lightness, strength, and perfect action. The reel and line, leaders and flies, will be such as the expert fly angler usually chooses. The reel may be any good 60 yard multiplying reel, the finer makes giving the greater satisfaction. In lines, nothing but the best quality of enameled braided silk should be used, of the smallest size at all suitable for bass fishing. Expert fly fishing is impossible with cheap, or large, heavy lines.

When the reel is fastened securely to the seat, pass the line directly through the first guide above and then once around the rod before passing through each successive guide and the metal tip. This manner of mounting the line strengthens the rod when handling a fish, and in no way interferes with the free running of the line in or out.

A 6-foot leader, of the best quality, with one or 2 flies attached, completes the outfit. No gaff nor landing net is to be used in bringing the fish to creel.

Of course, this style of fishing is from a boat. The angler stands in the stern of the boat, which is pushed, stern foremost, by his guide or oarsman. When approaching the water to be fished, the angler, starting with line about the length of his rod, casts out in front or to one side, strips off 8 or 10 feet more of line, draws the flies a few feet along the surface of the water, and with a quick, gliding motion of the upper hand, makes the back cast. Then, almost instinctively knowing when the line is completely straightened behind, he casts forward again. This the angler repeats until he has out the length of line that suits his fancy, or nicely reaches the desired spot. He continues to cast with 50, 60, 70 feet of line, dropping his feathered lures with the greatest nicety as to distance and accuracy, and with that gentle, fluttering, hesitating drop, so lifelike, so pleasing to the angler, so enticing to the gamy bass.

Thirty to 50 feet of line are usually all that are necessary. No line is recovered either by the reel or by stripping until the fish is to be brought to hand, unless the angler wishes to change the length of his cast.

The forward cast and the back cast differ from that with the one hand rod. The cast is made with the rod at an angle of about 45 degrees with the surface of the water and to one side of the angler ordinarily, but may be made from any position from the horizontal to the perpendicular. No whistling noise or prolonged whiff is heard when either cast is made. The secret lies in the perfect action of the rod when properly handled. This is true of all good casting. A perfect rod is essential to perfect casting. No one can make a greater mistake than to suppose that this style of casting requires

little skill, or that any cane pole will do for such fishing. I am not trying to convert anyone, but as a fly caster, fairly expert with either rod, I know that the method here roughly described requires fully as much skill as with the ordinary fly rod and landing net.

The angler using the long rod must be able to cast to either side with equal accuracy; that is, cast with either hand at the butt, so as to meet all conditions as to wind, shore line, and position from which the water must be fished.

You have learned to cast fairly well with the 2-handed rod and may do the fishing while I handle the boat and act as umpire. Do you see that bed of moss and lilies, bordering on the deep water? I shall push the boat up parallel with the moss and about 30 feet from it. Put out about 40 feet of line. Drop the flies gently just at the outer border of the moss and lightly draw a few feet along the edge. I shall go slowly so you may fish every inch of the likely looking water. See that opening in the moss ahead? When you get within reach of that, drop the flies fairly and squarely into it. A rush! a splash! He is a good one! I believe he took that Yellow May before it touched the water! An instinctive contraction of the muscles of the arms and he is hooked. Then comes the battle royal. Give him a fair chance to show what he can do. He probably knows a few tricks, but you must out-trick him. Keep your hand off the reel. I shall keep the boat away from him, and you are to conquer him at the end of that 50 feet of line. If he gets any slack for a moment he will bid you an everlasting farewell. He sulks! He rushes! He leaps clear of the water! He is making a noble fight, but you still have him. Look out! Don't let him get his head directly away from you or he will show you a trick that will end the debate. Ah! he begins to show signs of weakening. He is on the surface now with mouth wide open. You may reel in, but be ready for a last fierce effort on his part when he approaches the boat. Watch him, there! Watch him! That's it, bring him up again. No, sir, I shall not touch him; no gaff, no landing net. You must land him yourself. Careful now! Grasp the line with your hand holding the rod. Don't try to raise him out of the water with the line. Reach down gently and take him by the under lip with the thumb and finger. That's it! What a beauty! All of 4 pounds. See, the hook has dropped from his mouth. Well done! A single wrong stroke and he would have been off. You could have dragged him in, probably, by main force, or wound him in with quadruple multiplying reel, and then I could have scooped him in with a seine called a

landing net; but we are after sport, and love fair play. We won the battle this time, but do not flatter yourself that it will always prove so easy.

W. W. Gallaher, Mound City, Mo.

#### CAMPING AND FISHING IN WASHINGTON.

In the early part of June, 1900, my mother, brother Pete and I decided to spend a few days camping near some stream or lake where we could get enough fish for our own use while in camp. After consultation we decided on Chomokane creek, and if not satisfactory to move elsewhere.

The morning we left home was bright and sunny.

We stopped at the Spokane river for lunch at 11.30 a. m. At 1.30 p. m. we began our journey again, and arrived at the creek at 6.20, after a hot ride. Just before we reached the creek we met a man who told us a good place to camp. It proved to be an ideal camping ground in a small grove.

While we were eating supper a man came to our camp to see who we were, and we asked him how the fishing was. He held up 2 small fish, the result of several hours' hard work, he said.

After supper we took our rods, Pete went down the creek and I followed the creek up, but the fish did not bite well, and becoming impatient, I decided to cross and try my luck on the opposite side. The only means of crossing was a small poplar which had been blown down, so that it struck the water about a foot from the bank, making a good spring pole, the roots being the only thing that held it up. I climbed on it and started across. It was all right until I got near the end, when it began to sway up and down. As the tree sloped so much I could not go back, I was obliged to go ahead. That I succeeded in doing until I reached a place where the water had been running over the log and had made it slippery. Then I began to slide like a boy on an icy hill. I tried to jump across the remaining space, but my feet slipped from under me and I fell into the ice-cold water. It only came up to my waist, but it was so cold that I picked up my rod and started for camp at a smart trot. I had enough for the first night.

Pete came in soon after, and we were glad to see that he was carrying a large trout that would weigh 1½ to 2 ounces. He said he had a few bites, but by the looks of things we were not going to get enough fish to eat.

The next morning we had breakfast early and started down the creek, intending to walk as far as the falls and fish back; but about half a mile down the creek we came on a stretch of water that looked a likely

place for fish, and we threw in our rods. For a while the fish took our flies the moment they struck water. We fished slowly down the creek until noon, when we had caught 18, ranging in size from 6 to 9 inches. We had them for dinner, and that was the first time I had all the fish I could eat.

In the afternoon we fished the same water with the same success. At 6 p. m. we stopped fishing and found that we had 21 between us, just enough for supper and breakfast.

On our way back Pete wanted to cross the creek again, but the only tree we could find was a small one. He was determined to cross anyway. When about the middle he thought to try the strength of the tree, so began to sway up and down. At about the second move the tree broke and down he went, right to the neck in the cold water. We had forgotten to take any extra clothes with us, so Pete had to eat supper that night dressed in his overcoat and hat. Next morning we broke camp and started for home.

J. Dewar, Reardan, Wash.

#### DR. BENDER'S EXPLOIT.

The trout season opened in this State Thursday, and a number of fishermen from this city visited the numerous streams in this vicinity. Only a few catches have been made, many of those who went out returning without a single fish.

Dr. R. Bender was more fortunate than the rest, for he reports a catch of 97 trout, ranging from 7 inches to a foot in length. A number of his friends called at his home yesterday to view the fine collection, and the genial Doctor remembered many of his acquaintances with samples of his catch.—Jamestown, N. Y., paper.

In answer to my request for confirmation of above report, I received the following letters:

The report is true. April 15th I drove 15 miles and stopped over night with a friend on whose farm the stream heads. As soon as it was light enough to see I was on the stream, giving the early trout a chance to catch the worm, which they did nicely until dark that evening. Considering the scarcity of trout here, I always get my share, perhaps 5 times as many as any other fisherman in this section. My best catch averaged 7 to 12 inches. I expect to be able to report some more good catches later.

Dr. R. Bender, Jamestown, N. Y.

Since writing to you yesterday, I have been told that the object of your inquiry is to give me a roast in your magazine. Should such be the case, you can have my picture to go with it. I will also give you a little more information in regard to the

matter. The owners of the stream where I caught my trout will only allow some of their friends to fish once in 3 years; that is why I had such good luck. Half of my catch was divided among the owners of the stream, and, with the exception of one mess, the rest was given to my friends, both editors of the papers here being remembered.

Dr. R. Bender.

And thus it seems that this Doctor Bender fished from daylight until dark, so far as appears from his letter, without stopping to eat. Clearly he was fishing for a record and not for sport. If he had been a decent angler he would have been content to fish a few hours in the morning and then to rest, walk about the fields or the forest, study the birds, the animals, and the plant life and to enjoy communion with nature; but no, the Doctor was fishing against time. He feared that some one else might take more trout that opening day than he, and he must put in every hour and every minute of daylight in an effort to make a big score. Then the Doctor took a bunch of trout to the editor of each of the local papers in order to be sure that his exploit would be published far and wide, and, as usual, those editors endeavored to smooth down the bristles of the porker who tickled their palate. No, thank you, Doctor, I do not care for your picture; I have enough of such photographs in hand to last me a long time. You have gained sufficient notoriety from your present raid on the trout, and I hope that when you take time to think the matter over, you may decide that you have had enough to last you a lifetime; that you may hereafter be content to quit fishing when you get enough and to leave a few fish for true sportsmen who may come after you. Meantime, your number in the fish hog pen is 890.—EDITOR.

#### NEW HAMPSHIRE BASS.

June 8, 1903, L. and his wife, and my wife and I, left Boston at 5 o'clock p. m. en route for Lake W. We arrived at Concord, N. H., at 7.05, and after a short stop continued our journey, arriving at our destination at 8.40. We had engaged quarters at the W. house, and found everything satisfactory. Mr. F., the proprietor, said our chances were good, as they had been catching some big fish. We strung our tackle, and prepared for an early start the next morning.

We were called at 3.30 a. m., and 4 o'clock found us on the lake. We rowed to P. Cove, about 2 miles distant, and dropped our anchors; and baiting our hooks with helgramites, we waited for the welcome strike.

Mrs. L. caught the first fish, and after a heroic fight she landed a 3-pound bass. We landed 4 more in the next hour, and then

decided to try a spot down the lake. We were slowly rowing along, my wife trolling her line about 20 feet in the water, when there came a pull, a shriek of the reel, and a large bass leaped from the water in its mad fury to escape. My wife fought him until she was completely exhausted, and then handed me the rod, and in a few moments I had him in the boat. He tipped the scales at 4½ pounds. We caught 2 more 4 pounders this same day, and my advice to all who want the big ones is to try trolling with a helgramite. Don't go deep; 2 or 3 feet is deep enough.

As the sun was getting high, as our well burned arms and necks testified, we returned to the hotel, feeling well satisfied with our morning's catch of 7 beautiful bass.

We returned home the day following, and were unanimous in declaring our trip an enjoyable one.

A. B. Jackson, Boston, Mass.

#### A HANDY INVENTION.

720,136.—Fish Hook Releaser. John Hal-liran, Grand Rapids, Mich. Filed May 5, 1902. Serial No. 106,001. (No model.)

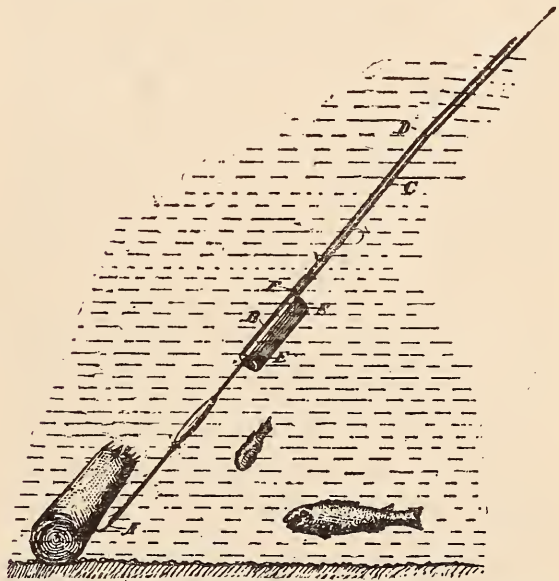

Claim.—1. Means for releasing a fish hook, consisting of a weight adapted to be temporarily and detachably connected to the fish line, and to slide down the same and to pass over the sinker and strike against the hook.

2. A tubular body having an opening larger than the sinker and a slot or opening in its side and extending from end to end thereof, whereby the weight may be temporarily attached to a fish line and allowed to traverse the same.

#### NIBBLES.

I own a small lake fed by a spring running about 200 barrels a day. The water is

rather hard, but water lilies flourish in it. Would any variety of game fishes do well in such a pond? If so, how could they be obtained?

A. S. Moore, New Castle, Pa.

ANSWER.

If your pond has a depth of 6 or 8 feet or more, and if the temperature of the water at the bottom in summer does not rise above 60 or 65 degrees, it is probable that large mouth black bass will do fairly well in it. You might try that species. Send to the Commissioner of Fish and Fisheries, Washington, D. C., asking for an application blank. When it is received, fill in the data called for regarding the pond. Have your member of Congress endorse the application, which should then be sent to the Commissioner, and you will then be supplied with the desired fish if your pond appears suitable.—EDITOR.

The following statement was sworn to before Claude W. Kortlander, notary public:

In 5½ hours, on May 15, '03, I caught 315 speckled bass at Ottawa Beach.

Wm. Kortlander, Grand Rapids, Mich.

Michigan seems to have more bristlebacks to the square inch than any State in the Union. It is strange that the decent anglers of that State do not thin out the herd. Tar and feathers are cheap, and there are hundred of miles of rail fence in that State that could be used to good advantage in transporting some of these fish hogs over into Indiana, or better still, into Lake Michigan. Kortlander's number in the fish hog book is 891.—EDITOR.

Joseph Gehrig, of Naples, who has been staying at Woodville, at the head of Canandaigua lake, 2 weeks, had the good fortune to catch 867 fish during that time, besides 24 muskrats and one wild duck.—Newark, N. Y., paper.

Gehrig's confession follows:

It is true that while camping at Smith's cottage, Canandaigua lake, last spring, I caught 867 fish. This is a fact.

Joseph F. Gehrig, Naples, N. Y.

You are hereby assigned to the large herd of fish hogs in this country and your number is 892. I wish I had the authority to round you up and brand you, so that everyone might know you at sight.—EDITOR.

725,706.—Fish Trap. John E. Hill, Center Harbor, N. H. Filed January 23, 1903. Serial No. 140,297.

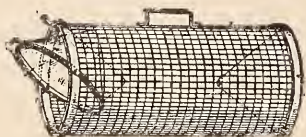

Claim.—I. A fish trap comprising a

body having pivoted transparent funnel shaped entrances, composed of glass, the glass being held in a ring, and a locking device to hold said entrance closed.

John Stevens, who lives near Lake Traverse, and who is too lazy to work, was caught fishing with 2 gill nets in the Minnesota river. He had about 75 pickerel and suckers. He was taken to Sisseton before Justice Somerville, fined \$100 and given 30 days in the county jail. Two boys were also caught fishing with a gill net. They were fined \$32 and costs. Our new game warden, Frank Nedjley, Roberts county, is enforcing the law.

S. S. M., Sisseton, S. D.

725,524.—Fisherman's Hat Band. William A. Wetmore, San Francisco, Cal.

Filed Jan. 7, 1903. Serial No. 138,132.

Claim.—I. A device for holding and carrying hooks, consisting of a band having an outer surface of compressible elastic material capable of detachably holding the embedded point and barb of the hook, and means for adjustably securing the ends of said band.

Two friends and I have just returned from Fulton chain, in the Adirondacks. We tried both brook and lake fishing, using Yawman & Erbe reels, Bristol rods and a Burlington refrigerator basket. All 3 are perfection in their way. We shipped 30 pounds of bass home in the basket. It was 38 hours in transit, yet our fish arrived as fresh as when caught.

G. Chase, Oneonta, N. Y.

I have caught 20 trout up here, within a few days; each weighing over one pound. The smaller ones were returned with thanks. One fellow weighed 3 pounds, 4½ ounces.

F. W. Jones, Moosehead, Me.

Can you go hunting or fishing or camping 12 times a year? Probably not; but for \$1 you can have 12 copies of RECREATION that will make you feel as if you had a vacation each month, when your copy reaches you and you read the stories of hunting and outdoor life, with which RECREATION is filled. Send in your \$1 now for a subscription, and have 12 vacations this year.

I have taken your magazine nearly 5 years, and as I can not wait for it to come through the mail, I buy it at the newsstands. I take all sportsmen's papers, and RECREATION exceeds them all in merit.

Dr. J. P. Brooks, Providence, R. I.

## GUNS AND AMMUNITION.

Anybody can shoot all day, but a gentleman will quit when he gets enough.

### ANSWERING BRITISHER.

In part answer to a communication signed Britisher, published in your February issue, I submit the following personal views based on some experience with the arms referred to.

The Winchester repeating shot gun is probably the best weapon of its kind. Its action is reasonably smooth and as compared with other models, reliable. I have never tried it as a ball gun, but see no reason why the shells, if properly loaded, should not work through the action without jamming.

I have never tried English shells in a gun of this description, but believe they would work satisfactorily, as they do in American double guns. Speaking broadly, however, the English shells I have used do not compare in quality with American ammunition manufactured either by the Union Metallic Cartridge Company or the Winchester Repeating Arms Company.

The best American double gun is the Parker. I have had no opportunity of comparing this gun with those of English make, in the matter of pattern, except with the Greener gun, which, while admittedly a splendid weapon, I have not found the equal of the best American shot guns in that respect. In finish, balance and nice working of parts, I have yet to see the American arm that bears comparison with those of the best English makes. However, I prefer the American shot gun as a sporting weapon.

The 50 caliber '80 model, Winchester rifle will shoot either 50-100-450 or 50-110-300 in the same rifle and with the same sight, within reasonable hunting ranges. This is not a long distance weapon; but within 300 yards, on large game, I have used the 2 cartridges indiscriminately in the barrels rifled for each kind and have found little difference in accuracy. The rifling in the 2 barrels is almost the same. There is hardly any question but that the 50-100-450 is the more accurate and deadly. If I had to stake my life on the accuracy, reliability and paralyzing power of a repeating rifle, I should choose this gun to-day in preference to any other in conflict with dangerous game. I do not believe the claim has ever been made that either the 30-30 or the .303 is equal to this cartridge in respect to stopping power, although what the new Winchester 35 caliber will do remains to be seen.

It is hard to make comparisons between the Savage rifle and the Winchester. They

are different in construction and although the Savage is more pleasing to the eye, there is probably little difference in efficiency between the weapons. Either would be improved by a detachable box or cylinder magazine.

The best rifle and cartridge for small game and target practice up to about 200 yards is largely a matter of choice. The Stevens is an accurate gun; so is the Remington. My own choice is the Winchester 25-20, either single shot or half magazine repeater, equipped with the Lyman combination rear sight, Lyman leaf in lieu of the regular rear sight on the barrel, and Lyman ivory bead fore sight. This gun is satisfactory either with smokeless or black powder. E. V. Papin, St. Louis, Mo.

### WANTS A SMOKELESS 38-55.

I noticed an article in December RECREATION regarding the pump gun. I believe the author was on the right track. I have used a repeating shot gun the past 6 years and on several occasions have fired the 6 shots, killing as many birds, within a few seconds. While the action of my repeater reminds me of a coffee mill yet it will do the work and has seen rough usage.

The other fellow condemned all pump guns as being destructive to game. I think the Marlin is the game bird's best friend. I have used that make of gun on various occasions. Both rifles and pump guns I have weighed in the balance and found wanting. The Marlin pump fails to eject the shells properly: Frequently it tries to force the shell through the top of the gun and so blocks the action. This only happens when the operator tries to make a double. Another objection is the recoil. With 3 drams of DuPont smokeless the gun will do execution in 2 directions. The barrel is placed too high with regard to the position of the stock.

I use a pump gun and possibly shall continue to do so. However, I believe all ejector double guns and pumpers should be discarded. Perhaps if I read RECREATION much more and find out the true definition of a game hog I shall hang my pump gun on the wall and go back to my first love—a Davenport single barrel.

My notion of an all around gun would be a 38-55 caliber with a barrel of smokeless steel. The rifling should be the same as in the old black powder gun of that style, one turn in 16 inches. The charge, for long range work, should be about 27 grains DuPont high pressure powder, with metal

jacketed bullet of 255 grains. Use the present 38-55 shell. It is better than any bottle-necked shell on the market.

The velocity of this bullet probably would not exceed 1,800 feet a second and should be more accurate than the 30-30. The present black powder load of 55 grains could be used; also for close pointed, grooved bullet of 115 grains. The pointed bullet will not mangle small game as would a flat tipped one. The bullet should have at least 2 grooves for lubrication. A gun of this description might be secured by having a 30-30 rebored and chambered to a 38-55. I believe the future demand will be for a larger caliber than the 30-30.

A. E. W., Logan, Ia.

#### A NEW RECAPPER.

723,838.—Cartridge Recapper. John B. Crepeau, Haverhill, Mass. Filed July 5, 1902. Serial No. 114,430. (No model.)

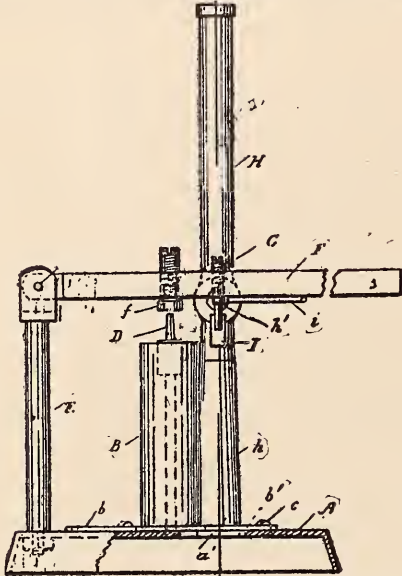

Claim.—1. In a recapping machine the combination, with a base plate having a hole in it, of a cartridge support slidable on the said base plate, a spring supported pin slidable vertically in the said support and retractable when over the said hole, and a pivoted operating lever provided with a hollow die arranged to one side of the said hole and a recapping pin arranged over the said hole, substantially as set forth.

2. A standard projecting from the base plate and supporting a reservoir for caps; of a spring pressed slide slidable crosswise under the reservoir and provided with a cap chamber, a cartridge support slidable on the said base plate, a spring supported pin slidable vertically in the said support and retractable when over the said hole, a guide secured to the said standard and engaging the cartridge rim when the said support is slid opposite the said slide, and a pivoted operating lever provided with a recapping pin.

#### TO INSURE SAFETY.

Frequent accidents caused by careless handling of guns, or defects in their mechanism, distressing as they sometimes are, do not seem strong enough as object lessons to prevent their recurrence. The recent chronicling of a fatal accident to a duck hunter emphasizes the importance of all devices which will make guns safe from accidental discharge. In the case in question the lock of the right barrel of the gun was defective, so that in closing the gun sharply the shock caused the hammer to fall accidentally.

Any gun is liable to do this through accident, misuse or neglect. The ordinary safety, as commonly used on the hammerless gun, would not prevent this in case of the failure of the notch or sear to hold the hammer when cocked. Numerous devices have been constructed with the object of affording additional safety; some so complicated and expensive as to be of little practical value, others so defective in principle as to be unreliable and useless. Among the most practical of these is the block system of the Baker gun, which is as safe from accidental discharge as any mechanism can be made. The device consists of steel blocks pivoted to the frame on either side and operated by the trigger. As the trigger is pulled, the block is revolved free of the hammer, but when released it rotates back into position between the frame and the face of the hammer so as to catch and hold the hammer, preventing its reaching the firing pin in case of accidental fall.

While the hammerless gun of itself is quite as safe to use, with such devices, as is the gun with exposed hammers, custom and habit have educated sportsmen primarily to the use of the hammer gun by reason of its earlier development, and they are frequently careless with the newer guns. Every practical device to prevent an accidental discharge is not only of great value, but should be insisted on by all users of guns, if not by legal requirement.

F. M. Farwell, Batavia, N. Y.

#### TO KILL WOODCHUCKS.

J. F. Roberts, of Cassville, N. Y., asks about the 32 Ideal cartridge for 'chucks. He says his 28-30-120 is too small for 'chucks at over 100 yards unless they are shot in the head or neck. I do not pose as a small bore crank or a cannon lanyard. I have not shot game from Hammerfest to the Antarctic archipelago, but I have shot and I can shoot woodchucks. My experience teaches me this:

Use an extremely accurate gun; have an easy hair trigger on your chuck rifle; shoot for the head; target your gun carefully for



50 to 200 yards and, after calculating the distance to shoot, set your sights for it.

Chucks should be hit in or in front of the shoulder, if one expects to get them. I have had 'chucks run one to 2 rods and get into a hole after I had shot them through the paunch with a 38-55-255.

I have shot most of my 'chucks at 50 to 150 yards, with a few at 200. A 'chuck's head at 150 yards presents such a small mark that unless I have a fine hair trigger I am likely to trigger off the mark. In shooting for the head it is not necessary to center it in order to score. I think it is much more enjoyable to hold dead on your game after elevating your sights properly, than to guess at the proper hold and then blame the gun for a miss. Be careful on a downhill shot or you will over shoot.

I shoot a Stevens Special, 10 pound rifle, 32 Ideal caliber, set triggers, combination bead and aperture front sight, and vernier rear sight. I think it perfection for 'chucks and target up to 200 yards.

Mr. Roberts' gun is powerful enough for 'chucks, but if he wants a gun to kill them wherever struck I do not know what to recommend. For its range no cartridge is more accurate than the 32 Ideal. He will make no mistake in trying it.

Guy M. Philips, Finleyville, Pa.

#### FOR TRAP SHOOTERS.

722,132.—Target Trap. William W. McQueen, Bay City, Mich. Filed September 29, 1902. Serial No. 125,240. (No model.)

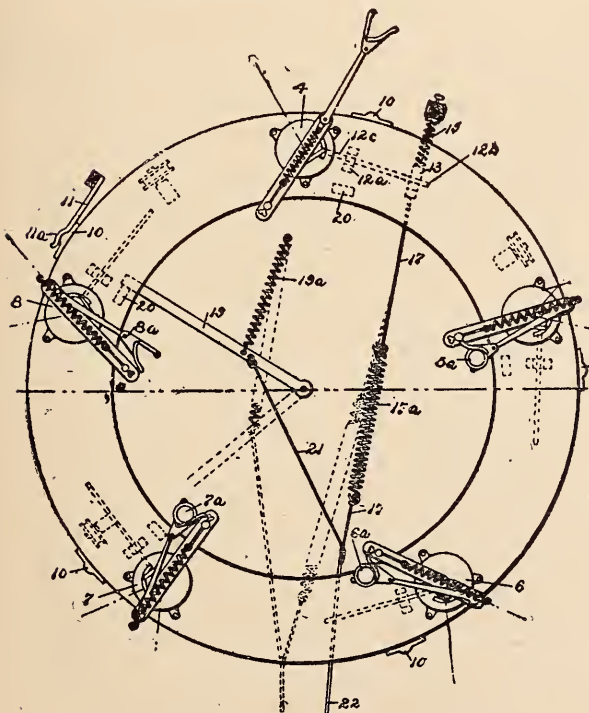

Claim.—I. In a target discharging apparatus a revoluble platform; a plurality

of target traps mounted thereon; means for revolving said platform to bring the traps successively into the predetermined firing position; and a stop in operative relation to the platform to arrest its rotation when the trap has reached the firing position.

2. Means for automatically locking the platform while discharging the traps.

#### USES THE 22.

The part of your valuable magazine that most interests me is the gun and ammunition department. I have seen several inquiries as to the capabilities of the 32 W. C. F. That cartridge is sufficiently powerful to kill all game as large as deer. Its accurate range is 150 yards. It will carry up to 300 yards, but one seldom kills game that far. I have a 32 Winchester single shot, 24 inch barrel, open sights, and as a rabbit killer it is perfection. The 22 caliber will kill deer. I have a friend who killed a yearling buck with a 22 Colt's repeating rifle with the short cartridge. The deer was hit between the shoulders. Have heard that a man killed a barren doe with a 22 extra long. Another time an acquaintance killed 2 black bears with one shot each, using the 22 long cartridge. If any subscriber doubts any of the above statements I will, on receipt of a letter from him, refer the latter to the shooters and have them reply personally. The first time I used semi smokeless powder I was so disgusted with it that I resolved never to use any more of it. I used it in a 32-40 rifle loaded bulk for bulk with black powder, but it would not shoot any better than black powder, in fact, not so well; and it left a deposit in the barrel similar to tar and hard to clean out. It made as much smoke as black powder.

Nimrod, Red Bluff, Cal.

#### SAVAGE TREATS SPORTSMEN RIGHT.

In your January issue R. G. Robertson, of Junction City, Ark., asks users of the Savage for their opinion of the arm. The Savage carbine .305 can not be beaten, and when using one I have yet to lose a deer struck in a vital spot. However, I always use soft nose bullets. For a light rifle that comes to the shoulder right every time and has the power behind it, give me the Savage .303. I have used and owned other rifles, and have on my wall at the present time a Winchester and a Mannlicher, both of which I like, but after the Savage. Then again the Savage people are square. Last November while I was on my annual trip to Pike county, Pa., the spindle and carrier of the magazine gave out from long use and refused to throw more than one shell into the chamber. That would have left me in bad shape had we found the bear we were

looking for. I wrote the Savage Company full particulars Tuesday and the following Friday I received a new patent spindle, carrier and spring complete, which worked to perfection. Could one ask for more? I wrote twice asking to pay for it and they replied, "with their compliments and hopes that the trip would be a success." Mr. Robertson will not make a mistake by giving the Savage a fair trial. Let us hear his decision in the near future.

Alfred T. Ives, Brooklyn, N. Y.

#### EXPLAINS ABOUT COX SIGHT.

Yours of recent date at hand and noted. The sight that Cox made and showed me was O. K. It was different from the one he put on the market. It had the rear lens in the rear Lyman aperture, but the front lens was in the disk of the No. 17 Lyman. That sight was a good one for shooting purposes.

After he had me see and test that sight he came to me and said he had improved it, by putting the front lens in the rear slot on a Beech combination front sight stem. He asked me if I would write a letter to RECREATION endorsing the new sight. I said I would, thinking the sight would be the same as, or better than, the one he showed me. That is where I was lame. I own to-day the gun he had the first sight on, but it is not there now. I do not know anything of Cox's business, but I do know his partners are all honest men, and if they are in trouble it is by a misrepresentation on someone's part. You may draw your own conclusions.

I am sorry that trouble has come from my letter, as I do not think the new sight Cox is putting out is worth anything.

J. W. Stapleton, York, Neb.

#### COMPOSITION OF RIFLE BULLETS.

Will RECREATION kindly give a reader information on the composition of rifle bullets and laws governing them? I have a Winchester 32 Special and do not know what composition is best, reloading with 40 grains of black powder. As far as I can see, the Winchester do not give the composition of these bullets in their catalogue.

Joseph A. Anderson, Goldfield, Col.

I referred this inquiry to an expert rifle-man who replies as follows:

No law governs the composition of tin and lead or any other alloy to make bullets harder than pure lead. Bullets are generally hardened to avoid too much upsettage. The higher the pressure generated from the powder and the quicker the twist, the harder the bullet should be. In almost all 16 inch twist rifles, which means one turn in 16 inches, lead bullets are usually about one

part tin to 20, or one part to 40, of lead. For the 32 Winchester Special rifle with 40 grains of black powder I recommend one part tin to 25 of lead. With high pressure powders, the quantity of tin should be increased to make the bullet correspondingly harder.

#### NO FAULT OF PUMP.

Noting the attacks on pump guns and bird dogs in RECREATION, I claim, although I am not an advocate of the pump, that because a man uses a repeater and a bird dog he is not necessarily a game hog. I am the owner of a Winchester pump gun and 2 bird dogs, a pointer and a setter, both thoroughly trained; yet I would rather be called a thief than a game hog. A man may use any weapon best suited to his wishes, and yet be a gentleman if he has decency enough to quit when he has enough. I derive more pleasure from watching the working of my dogs than in procuring large bags of game.

Mr. Double Barrel's article in December RECREATION is all right, but these "murderous engines of destruction" will be used as long as there is no law prohibiting their use. As soon as there is, I shall be the first to take mine by the barrel and throw it into the lake. The brute with a double barrel can make just as big a fool of himself as the swine behind the pump, for he can follow the flock and clean up just the same. It only takes longer.

O. E. Raynor, Meadville, Pa.

#### A LOVER OF THE REPEATER.

I am the owner of a 30-30 pistol grip, half magazine, take down rifle fitted with 3 Lyman sights. The gun is light and embodies all that can be desired in a rifle for general hunting purposes. I also own a 12 gauge repeating shot gun, which is a good all around firearm, but think the 16 gauge has an advantage in not being quite so heavy. However, the repeating shot gun in either gauge is ahead of the double gun, and seems to me more humane, as a wounded bird or rabbit has small chance of getting away.

Deer were numerous around here last fall, but had more than an even chance with the hunter on account of the first fall of snow forming a hard crust which would break underfoot and make such noise that a deer could hear and see the enemy long before the hunter could locate the game. A notable feature of the hunting last fall was that few does were killed. Full grown and unusually large bucks suffered the most, which fact can, I believe, be attributed to the ground being covered with snow.

Wm. S. Ferm, Hurley, Wis

## SAVAGE NOT TO BLAME.

W. A. Con's criticism of the Savage rifle is not fair. Because a rifle jams once is no reason it should be thrown away as useless. He should try it thoroughly, and if it persists in doing the Marlin act he should then discard it and complain to the manufacturers. Any rifle will jam occasionally if pumped slowly and spasmodically and canted while doing this; and it will jam with a cartridge that does not fit. Every man who writes to the gun department of RECREATION claims his gun is the best made, none other being worth having. One first class gun is as good as another, while the man behind the gun is wrong. I own a pump and a Clabrough, and these I consider as good in shooting qualities as any other first class ones. The pump I prefer to a double gun for late fall duck and goose shooting, while for snipe, black and teal ducks I use the Clabrough.

I notice the Savage Arms Company has the space in RECREATION the Winchester Arms Company had.

S. E. Sangster, Port Perry, Ont.

## A NOVEL PATENT.

726,399.—Gas-Operated Firearm. Andrew Burgess, Owego, N. Y. Filed November 3, 1902. Serial No. 129,912. model.)

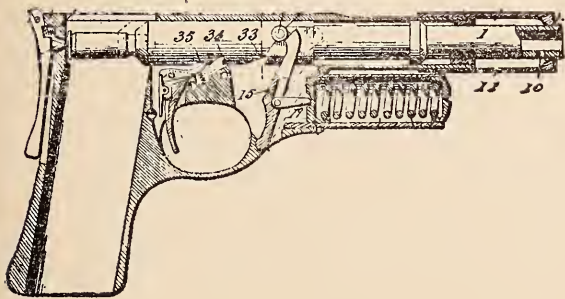

Claim.—1. A forwardly moving barrel, a gas receiving chamber, an opening from the barrel to said chamber, and means by which the gas pressure in the chamber acts to press the barrel forward, etc.

## A FRIEND ASKS ADVICE.

Can some of your helpful sportsmen, which all real sportsmen are, help me on a personal proposition? I was a reasonably good shot until I lost the sight of my right eye by an accident. Since then I have shot but inefficiently. I still twist my neck over clumsily and use the right side with the left eye. Of course, anyone would say, try to take the other grip; but I can not. I have tried it faithfully. I feel as if I were sewing with mittens on. Somehow, the muscles and nerves and remaining eye do not work together.

Can I have a stock made with much drop and twisted to the right at the grip, if

necessary, so there will be all the old easy balance and unconscious dropping to place in an instant, and so I can shoot again, without bother, in the good old way? Surely I am not the only shooting man who has suddenly lost the use of his right eye, and I hope, too, I am not the only one inadapt-able and incapable as to left hand shooting.

Stanley Waterloo, Chicago.

## AN OLD ARM.

One of my friends has an old muzzle loading rifle which was made by the Taylor Rifle Works, Vienna, Ohio. The stock is made of curly grained wood, with Swiss butt plate of brass. The lock is fitted with a set trigger. On the barrel are a plain open sight and a globe sight, which screws into the tang for elevation. It may be turned down when not in use. On the right side of the stock is a brass cap, or patch box, with a spring cover. The barrel is extra heavy. It has twist rifling with 5 grooves about 1-16 inch wide and 1-32 inch deep. The gun shoots the 32 caliber round or conical bullet, and weighs 10 or 12 pounds.

L. M. Badger, Ouaquaga, N. Y.

## NOTHING SMALLER THAN 22.

Will anyone tell me his experience with rifle or pistol, and ammunition for same smaller than 22 caliber? I am thinking of ordering a rifle of a caliber about 12-100 to 15-100 of an inch, high velocity. I am not convinced that this is impracticable.

Edgar C. Barnes, Troy, N. Y.

## ANSWER.

As far as I know, there is no rifle or pistol made of a smaller caliber than 22, and nothing smaller would be practicable. It is extremely difficult to thoroughly clean a 22 caliber, and the difficulty would be increased in the same ratio that the caliber of the rifle would be decreased. I do not advise you to invest in anything smaller than a 22.—EDITOR.

## SMALL SHOT.

Three years ago I bought an Ithaca gun and commenced trap shooting. The first day I broke 12 out of 25; second day, 14 out of 25; third day, 16 out of 25; fourth day, 19 out of 25. In 6 months I shot against a Parker. I broke 59 out of 65. That fall I returned my gun to the factory and had an extra set of barrels made; 28 inch cylinder for brush shooting. During the 60 days our season lasted I shot 40 ruffed grouse, besides other game. I have now shot thousands of loads out of my gun. It is as tight as the day it came from the factory. There is no better gun for the money and the firm will do just what they say.

S. S. Dice, Ligonier, Pa.

In January RECREATION W. A. Bau claims that the Savage .303 will show greater penetration with the grain of the wood than across it. I do not agree with him. A bullet plowing its way into a piece of white or yellow pine lengthwise with the grain has more or less sponginess to contend with, which would, to a great extent, check the penetrating power. The same material across the grain is more brittle and would permit of greater penetration. I have tested this point carefully with a 25-30 Winchester. I should like to hear from others in regard to this question.

Henry W. Solomons, Jersey City, N. J.

I have been in the gun business for years and write this letter for the benefit of those who complain because the Winchester .22 rifle uses only one length of cartridge. I am a great admirer of the Winchester and think it one of the best and safest rifles in use, especially with the change I am now making on it. With the new attachment, which is simple, the gun will take C. B. caps, short, long and long rifle cartridges, either singly or mixed in the magazine, as the shooter may desire. The change does not mar the beauty or the simplicity of the rifle. H. T. Rushing, Jackson, Tenn.

In March RECREATION are 2 items attacking the Savage rifle. Any rifle is liable to go wrong occasionally. I sell rifles and have had hundreds returned to me with instructions to correct defects in them, either real or imaginary, the manufacturers' or the sportsmen's fault. This does not justify rushing into print and abusing these well known arms, using the columns of a non-partisan journal. Some of the most celebrated sportsmen in the world, including our President, Theodore Roosevelt, use and endorse the Savage rifle.

A. C. Rulofson, San Francisco, Cal.

I devour RECREATION each month, and commend your fearless attacks on all slaughterers of game. The suggestion that high hunting license be resorted to is evidence that some men who love field sports wish to deprive others of those pleasures.

Pump guns have come to stay. It is useless to suggest a return to muzzle loaders. Such rifles are of the past. The only means to protect game and insure an increase is to pass laws that will compel men to stop within reason.

John E. Lancaster, Chicago, Ill.

If J. F. Roberts, of Cassville, N. Y., will use a Colt's 22 caliber rifle and Winchester greaseless bullets he will meet with much better success. Again it depends on the

man. I am the owner of a Colt's New Lightning magazine rifle and use Winchester short greaseless bullets entirely. They are good up to 75 yards and the ½ long Winchester smokeless are good up to 100 yards. I can kill a muskrat at 100 yards using the ½ long smokeless.

J. E. Tanner, Columbia, Ohio.

Will readers of RECREATION give some information about Colt's lightning magazine repeating rifle, 38 caliber? Say if sure for deer or black bear, and state range for smokeless cartridge. Do not suppose it powerful enough for moose? Should like, also, to hear about Colt's L. M. R. rifle, 22 caliber, shooting .22 short and long, in comparison with Winchester, same caliber, using either black or smokeless.

S. L. Dobbin, Oneida, N. Y.

723,747.—Sight for Guns. John Smith, Natrona, Pa. Filed September 26, 1902. Serial No. 124,952. (No model.)

Claim.—1. A sight for guns comprising a piece of glass having a point obscured transparency in the body thereof, and a lens-like formation enveloping said point.

2. A piece of glass containing a minute granule or bubble embedded therein and having lens-like strata enveloping said granule.

I notice in February RECREATION a letter from J. F. Roberts in which he condemns the 22 cartridge for woodchuck shooting. If he had ever tried the 22-7-45 he would have reason to think differently. I have for some time used a Stevens Favorite chambered for the 22-7-45 and with the bullet placed in the head, neck or shoulder it will kill instantly any woodchuck.

Geo. C. H. Warner, Albion, Mich.

The 31st annual meeting of the National Rifle Association of America will be held at Sea Girt, New Jersey, September 2d to September 12th, inclusive, together with the 12th annual meeting of the New Jersey State Rifle Association and the 4th annual meeting of the United States Revolver Association. Special reduced rates to Sea Girt will be given by many of the railroads.

Are you making up a list of books for your fall and winter reading? Do not fail to include RECREATION. Nothing else will give you so much pleasure for \$1. If you care for hunting, fishing, photography or nature, you can get more joy out of RECREATION than from any other source except an actual day afield. Send in your subscription and those of your friends.

## NATURAL HISTORY.

When a bird or a wild animal is killed, that is the end of it. If photographed, it may still live and its educational and scientific value is multiplied indefinitely.

### THE OSPREY, OR FISH HAWK.

The numerous islands of the Penobscot bay, on the coast of Maine, are a favorite summer abode of the osprey, or fish eagle. These migratory birds leave this region about the middle of September and return the middle of April. They always seek as high a position as possible on which to build their nests, usually the tops of high trees; though, in some of the small, treeless, uninhabited islands they occasionally build on the rocks, or high reefs. Only a few trees are suitable for them, such as have had the tops broken off by storms, leaving at least 3 wide spreading branches as a foundation for the nest.

A fish hawk family consists of 3 birds, 2 males and one female; and when the 3 or 4 young members become nearly grown, the family require a good deal of room; hence the nests are often 5 or 6 feet in diameter, nearly flat on the top, with a small depression in the middle, where the eggs are hatched.

In one cow pasture in Islesboro, there are about  $\frac{1}{2}$  dozen nests on the tops of high spruce trees, and one of the nests is nearly  $\frac{1}{2}$  a century old; the same family, or 3 of the survivors of the family, having returned year after year to occupy their summer home. On their return in the spring their first business is to make repairs, for some of the old material necessarily decays; but the nests are so strongly built that though exposed to heavy gales and storms they are never blown away. There are a few other nests that are 15 or 20 years old. The birds will always return in the spring to the nest they left the previous autumn, as long as the tree stands and they themselves are not disturbed.

Ospreys are such beautiful birds, so large, so graceful on the wing, so innocent, so tame, so unsuspecting; sailing within a few rods of houses to pick up pieces of cloth that people leave for them with which to make a lining for their nests, that only a few heartless vandals will disturb them. A few feet from the dam which makes the Dark Harbor bathing pool, by shutting in the tide, was a nest on the top of a spruce tree. The Islesboro inn and a number of summer palaces of wealthy visitors are near. The guests at the inn, and others also, used to sit on the dam, near the nest, hours at a time, watching these interesting birds. One male bird sits majestically on a neighboring tree to guard the nest and the female bird sitting on it; but both males are never far away at one time. They catch their

fish, fly to a tree top and eat it. The female also gets her own food, being absent only long enough to secure it. As soon as the infant birds break out of the shell, the 3 old ones sit around the edge of the nest most of the time for several days, keeping up an incessant jubilation. One of the parents catches a fish, takes it to the nest, and while his claws are on the fish's head, he tears off small pieces with his beak and places them in the gaping mouths of the hungry progeny.

When the young become nearly grown, and while still stubbornly refusing to leave the nest to the beseeching parents, the old birds, after their patience is apparently exhausted by coaxing, forcibly pull the youngsters out. The young bird flutters and cries most piteously, realizing its danger in falling from the lofty tree top; but just before it should reach the ground the parent darts quickly under it, takes it on its back, and deposits it safe in the nest. This process is repeated till the young bird has sufficient confidence in itself to go alone.

The second lesson, that of catching fish, is easily learned. The young bird will follow the old one out over the water, and soon imitate what it sees done. The osprey balances itself almost motionless some 75 or 100 feet from the surface of the water, and when a fish comes to the top the osprey drops like a stone, lifts the fish in its claws and sails proudly away, always making a peculiar, joyful noise as he goes. If he drops his fish on the way, he never stops to pick it up. He is successful in catching his prey, about 3 times out of 5.

In May, 1901, a paper hanger from Boston visited the nest by the Dark Harbor bathing pool, and while one of the unsuspecting birds was sailing around him, only a few feet away, he leveled his weapon and shot it. This broke up the family, and those bereft never returned. The people who had, summer after summer, derived so much pleasure from watching these interesting birds did not say pleasant things about the Boston paper hanger and his brutal deed.

In 1900 an osprey family built a nest on 4 horizontal wires of the telephone, laying the foundation with long sticks and poles, then most skilfully weaving in smaller material, and finally fastening the whole nest, with its bushel of twigs and lining, firmly to the crossbar and telephone pole. Another family built on the top of a large, old fashioned chimney of an uninhabited house, having undisputed possession for years, till

driven away by other occupants who thought they had a better title. A vessel lay at anchor in one of the harbors here, during the winter and early spring. The fish hawks claimed it, and built their house on the rigging and crossrees at the top of the main mast, fastening it firmly around the tall top mast. In the early summer the former owners asserted their rights. They weighed anchor, hoisted the sails and started for Bangor, 30 miles up river, for a load of lumber. The fish hawks resisted this intrusion with marked displeasure, and held tenaciously to their home till the vessel reached Fort Point, some 6 miles away, when they gave up the struggle and sailed away.

A few years ago a man climbed a tall spruce tree near his house, and sawed off the top on a level with 3 wide spreading branches, as a favor to a fish hawk family; should one come along. The birds came and examined the tree. Finding that there was no upward stem, a few inches long, above the branches, to which they could fasten the nest, they quickly devised a plan, for "necessity is the mother of invention," even with fish hawks. They began on the next row of limbs, some 2 feet below, carrying long sticks and building up by cross laying, till they reached the top branches, fastening all their work as they went, by fitting in sticks at various angles, as well as perpendicularly. In this way the nest was fastened to the tree, and the top was sufficiently broad to accommodate the whole family when the young became grown. They always plan for a full family when laying the foundation of their house. If a stick they bring does not fit the place they planned it for, they throw it away and try again. Under the trees there is much discarded material. More than a dozen years ago some children were playing around a house one hot afternoon in the spring, and a little boy took off his new jacket and threw it on the ground. He came in at supper time and soon went to bed. The next morning he went out to get his jacket, but it could not be found. His mother scolded him for not knowing where he left it. A few winters ago a gale of wind blew down a large tree near their house where the osprey had had a nest for a generation or 2, and there was the boy's lost jacket, which the hawks had stolen and put into their nest for a lining.

Cranes and fish hawks are sworn enemies. The former build in the middle of a tree, the latter on the top. The crane is so long and slow of motion that the supple osprey can often hit him with his wing and get away; but sometimes the crane will manage to deal a terrible blow, as his neck is so long. There is a colony of cranes in a thick spruce grove near several ospreys'

ests. The birds all get their food near the same place, though the cranes in shallow water, and thus have to cross each other's paths; hence many battles.

On the top of a tall tree, on a neighboring island, some eagles had a nest for many years, but they have not returned for several summers. Two years ago the fish hawks repaired the nest, and now hold it in undisputed possession.

Geo. E. Tufts, Islesborough, Maine.

#### WILD PIGEON REMINISCENCES.

The Hon. John F. Lacey states in RECREATION that the wild pigeon has been exterminated. I have taken considerable pains to ascertain if the wild pigeon has in fact become extinct with the following results.

In September, 1900, a friend and I saw a flock of 9 or 10, the first I had seen since the great flight and nesting in Potter county, Pennsylvania, in 1871 or 1872. In September, 1901, P. Freeman informed me there was a small flock of wild pigeons staying around his woods and fields, and that he was trying to protect them. I saw him a few days ago, and he said he had seen them frequently this fall. My brother while driving in the vicinity of Mr. Freeman's farm during June, 1902, saw a small flock of wild pigeons and was able to ascertain that it contained both male and female birds. Having been familiar with the pigeons in former years, I can not be mistaken as to the birds I saw. In 1871 or 1872 I spent a month with an old gentleman, who was engaged in netting pigeons, and saw hundreds of them caught with a net; but will refrain from describing the process as I hope the art will never again be revived. At that time there were thousands of young squabs taken out of the nests just before they were fledged; the trees containing the nests being felled and the young birds gathered from the ground, only the breasts of the birds being saved. I saw barrels, tubs and firkins filled with the salted breasts of these young birds and acres of timber destroyed to facilitate the slaughter. In March, before the pigeons commenced nesting and before the snow was entirely gone, I saw thousands of them feeding on beech nuts. At that time the males and females came together to feed; but after they commenced nesting, and until the young were fledged, the male birds came to feed just after the break of day, and could only be attracted to the net by the flyer and stool bird before they had fed. After feeding, on the return to the nesting, they made a swift and direct flight, and as the nesting was only 20 miles from the nets it required haste to rearrange the nets and blinds to be prepared for the

flight of the female birds, which only left the nests after the male birds returned to take their places. During the nesting I never saw either males or females feed on nuts or grain. They sought the low, damp meadows and pastures, and fed on worms, white grubs and snails. They alighted on the edge of a field and seemed to clean it of food as they moved along. Those in the rear, when they had exhausted the food, flew over the rank in front, and they in turn repeated this operation during each feeding, never feeding on the ground others had fed on. One could always tell when the young were fledged, for males and females would then come together to feed, and in about a week the young would accompany them.

The food on which the young are fed while in the nest is a curd formed in the crops of the old birds and delivered to the young in the same manner observed by our domestic pigeons in feeding their young.

On 2 occasions I saw the attempt made to breed the wild pigeon in confinement, but without success, although the birds when taken from the nests would readily become perfectly tame.

W. J. W., Willsville, N. Y.

I have read your notes on the wild pigeon with deep interest. I am aware that there are a few small bunches of wild pigeons remaining in different parts of the country, but Mr. Lacey was practically correct in saying they have been exterminated. I have printed several reports in RECREATION during the past few years of the appearance of small flocks of pigeons in various States, but as far as I can ascertain they are still decreasing instead of increasing, as we had hoped they might.—EDITOR.

#### A TRAGEDY IN THE ZOOLOGICAL PARK.

Those who are responsible for the care and management of wild animals in captivity are constantly reminded that it is impossible to know what deed of violence an animal may perform, until it is actually done. Often the cunning of a caged animal is past finding out, until the event occurs. Then we are all post-mortem philosophers. As a striking and painful instance, take the case of Lopez, the jaguar.

From the day of his arrival at the park last May, Lopez has never been one of the snarling kind. On the contrary, he constantly manifested what was considered a playful disposition. Most large felines of savage disposition show it by snarling, and charging against their bars. Lopez, on the contrary, seemed anxious to play with anyone who came near his cage, and had a trick of rolling on his back, with his paws

in the air, after the manner of a good natured house cat.

In Hamburg, a female jaguar, nearly full grown, was bought as a cage-mate for him. Lopez was the first animal placed in the first finished cage of the new lion house, weeks before the workmen had completed the other cages. Inasmuch as the female had been 6 weeks in her traveling cage, and sadly cramped for room, it was decided to place her in the lion house without delay. In order to ascertain the temper of Lopez toward her, her cage was raised to the level of his, and the 2 were placed with their bars in close proximity. Lopez was greatly interested by the stranger, and attempted to play with her through the bars. She observed him without any manifestation of fear, and seemed to be interested by the prospect of a larger cage, and a companion in captivity.

For 2 days the female's cage stood in the position described, and during all that period Lopez manifested not the slightest ill temper or displeasure toward the new arrival. At the end of that time the director held a consultation with the keepers, and it was agreed that it would be safe to admit the female to the cage of Lopez. The doors were opened, and without the slightest fear or hesitation the female jaguar walked into her new home. Instantly the whole nature of Lopez changed, or rather, his real nature came to the surface. His scheming for an advantage had been successfully carried out. With a savage growl, he rushed upon the unsuspecting female, seized her by the right side of the neck, and held on, biting savagely. From the first instant the female seemed utterly powerless. With an iron scraper and a hardwood pole 10 feet long Lopez was beaten over the head and prodded in the face; but he only shut his eyes and tightened his grip on the neck of his victim. In the midst of his punishment, he rose from the floor, carrying the female in his jaws as a cat carries her kitten, and walked to the opposite side of his cage. It was nearly a minute before the savage creature was forced to quit his hold, and resist the attacks made on him by the keepers. When he released the female, she lay on the floor, motionless, and in 2 minutes more was dead.

At first it was supposed that one of Lopez's canine teeth had penetrated the jugular vein of his victim; but the autopsy made by Dr. Blair revealed the astonishing fact that 2 of the neck vertebræ had been completely crushed, and the spinal cord penetrated by fragments of bone. The injury was inflicted by a square bite, with no wrenching. As an exhibition of the strength of the jaguar's jaws, it was quite as astonishing as it was unexpected and shock-

ing. As a consequence of this act of treachery, Lopez will live in solitude the remainder of his life.—Zoological Society Bulletin.

#### THE RATTLEBUG.

OLD SILVERTIP.

Lots of readers will wonder what sort of a bug that is. Well, it is a bug with no legs, rather a long body and is peculiar to the "wild and woolly West." People have theories about this bug. There is a common saying here, "Show me a prairie dog town and I will show you a rattle-snake." Now in all my experience with rattles, I have not found over 6 in prairie dog towns. I have found the rattlers mostly in the neighborhood of water, on rocky side hills or sage brush flats.

I once saw a sight that I have often wished to see again. There was a heavy fog with a light rain, making it impossible to see over 50 yards. I was walking along quietly, expected to get a snap shot at a coyote near a dog town, when I saw sitting at the mouth of one of the holes 2 owls. They were the exact color of gold; not another color could I see; and they were not over 3 inches in height. As soon as they saw me, down the hole they went head first. Can anyone tell me the name of those owls? I would be much obliged for information on the subject through RECREATION.

To return to the rattlebug: it is a popular belief that this reptile will always rattle before striking. I have struck them before they could rattle, but they do not always rattle before they strike. Once I picked up my dish rag from the ground where it had fallen and under it was a rattler all coiled up; yet even while I was killing him he never rattled once.

You hear the expression "snake bite." No snake can bite. They strike. Their head and jaws are loosely connected and they have no power to bite. Again you will hear people say, "Look out, a rattle-snake will spring at you." I have hit them with sticks, poked them and have done all I could to make one spring at me, but, up to date, not one has sprung. I have seen them raise 1-3 of their body off the ground and strike, but only the part elevated did I see move.

I killed a rattler last summer and on cutting off its rattle I noticed it was different from any I had seen. When cut off it was bluish black all over. It has now turned a dirty flesh color.

I was camped one night on a sage brush flat with my bed on the ground as usual. Along in the night I was awakened by I knew not what. I had learned never to jump or sit up when first awakened and on no account to roll over, and have so

schooled myself that I never move until I know what's up. I heard a purring sound like that made by a cat. "A skunk," thought I, and was just going to slide out when something touched my leg and I knew it was a snake. I can not describe my feelings. As soon as it stopped moving the purring began again. It came up slowly toward my face. Every time it moved the purring ceased, and when it stopped it was so close to my face that I could feel its head on my breast. I was desperate. I made a jump. How it was done I don't know nor do I care. It landed me nearly on top of the stove. Out of the flap of the tent I went and got the axe. Perhaps I didn't make mince meat of that rattler. Can anyone tell me if a rattler will always purr in that manner when in bed with a person? I am not anxious to try it again for proof.

#### TREATMENT OF SNAKE BITE.

In RECREATION I note queries of V. A. L., Albany, N. Y., regarding venomous snakes, and believing it a subject of vast importance to sportsmen, I submit information he solicits, together with a few remarks for those interested. First find your snake. Procure a cane long enough to prevent coming within striking distance, say 6 feet for a rattler; fasten a strap on the side at one end, pass it over the end and through a staple on opposite side, forming an adjustable loop. Attach a stout cord to end of strap, slip the slack loop over the snake's neck, recover slack quickly and fasten firmly, and you have your captive to examine at leisure.

The venom glands are vital, hence their removal insures death. Usually snakes robbed of their fangs refuse food and die of starvation.

It is deplorable that so few physicians know the proper thing to do in a case of snake bite. Several instances of this kind came to my notice while living West of the Mississippi. Each year marks the unnecessary death of thousands of snake-bitten people through a lack of knowledge of the proper treatment. In India alone the death rate runs into hundreds of thousands annually, outnumbering deaths from all other causes. Queen Victoria contributed from her private purse large sums of money annually to establish and maintain a corps of eminent physicians who should make the subject of antidotes for snake venom a life study. In this work governments have co-operated, and reptiles innumerable have found their way into crates and sacks all over the globe, yet so far permanganate of soda is the only known agent that will fully destroy the venom without also destroying the tissues and allowing the flesh to become soaked with watery blood.



Venom consists of peptone, globulin and salt. Venom globulin produces paralysis of the spinal nerves and rots the tissues of the blood vessels. Venom peptone dissolves the blood so it can not clot or longer flow in the rotted channels. Rattlesnake venom has 25 per cent. more venom globulin than venom peptone, and in America a bite from a rattler, if in the extremities, rarely proves fatal. If on the trunk or head, however, it is a serious matter in proportion as it is a one or a 2 fang wound, in the flesh only, or in a vein or artery. The usual quantity injected in a 2 fang wound by a rattler is about one teaspoonful.

If snake bitten, use the knife if possible, and tightly place 2 ligatures, one on either side the wound. Inject freely, through a hollow needle, permanganate of soda; or, if not obtainable, iodine, perchloride of iron, or bromo-hydric acid. In all cases procure and use the antidote speedily. Time here asserts its worth. Give whisky copiously, not fearing intoxication; the venom counteracts that up to a surprising quantity. It is, however, no antidote, but is what the heart calls for to assist in keeping up its action, the tendency being to paralyze that organ.

No sportsman should ever take an outing where venomous snakes are known to exist without providing himself, in some handy pocket, with a hypodermic syringe charged with one of the drugs mentioned. He might have the satisfaction of saving the life of a friend if not his own.

A. K. Stetson, North Pomfret, Vt.

#### DRUMMING OF THE GROUSE.

A particular description of the manner in which the male grouse drums is given by Edward Banks, of Rice county, Wis., who has spent some time in observing it at this pastime, if such it may be called. Early in May, Banks heard a grouse drumming. As usual, the sound seemed to be a long way off, but he decided to investigate and began moving softly among the trees. He found the bird within 50 yards, got within 20 yards of it, hid behind a big birch and watched it. The grouse stood on a dead log nearly 3 feet through and bare of bark. It was standing motionless when Banks saw it, apparently asleep. Soon it began to show signs of uneasiness, poking its head first to the left and then to the right. Then it squatted, bringing its breast within an inch of the log, and began to drum.

The drumming lasted 8 or 10 seconds, then ceased, and the bird became once more erect. Fully 5 minutes elapsed before it drummed again. As long as he watched it, intervals of 3 to 5 minutes passed between the drummings.

The grouse always preceded the drumming by the signs of uneasiness, moving its head to right and left, sometimes shifting its feet on the log. Just before the drumming started, when the bird had squatted into position, it spread out the gray feathers of its tail as widely as they would go, making a fan, just as the turkey gobbler spreads its tail when it struts. This fan the grouse brought down on the log and held there, pressing it against the timber as tightly as possible, and it kept it so while the drumming lasted, not relaxing the tension until the last sound had

ceased. While drumming, the head was stretched far forward and the neck was rigid.

The bird always began its drumming by 2 or 3 tentative flaps, given slowly and producing only a softly muffled noise. It seemed to be doubtful of its ability to drum and appeared to be trying how it would go. After these 2 or 3 flaps it brought its wings sharply against its body and sailed out into the full tide of its instrumentation. The strokes, at first slow, increased swiftly in rapidity, finally merging into the thunderous roll made by the wings of the grouse when in full flight. Then the drumming ceased abruptly, not shading down into slowness and softness, as it had begun.

Sometimes, having completed its beats, the grouse would walk up and down on the log for 2 or 3 feet, evidently immensely proud of itself. Always when the drumming was resumed it took its original position, standing with its feet in exactly the same place.

In making this sound the rear edges of the wings were brought down and forward. The grouse, in fact, seemed to be scooping its wings forward and slapping itself on the breast in much the same manner as a man slaps himself on the chest in cold weather; only, of course, the wings were not crossed. The wings were brought as far forward as possible and outstretched before they were slammed against the body.

On every clear day since then this grouse has drummed on the same log, standing in the same place. It keeps it up for hours in the morning, goes away shortly before noon and returns about 2 o'clock in the afternoon, drumming until nearly sunset at intervals of 5 minutes.

Banks is certain the bird does not brush the log with the tips of its wings and that such contact has no part in producing the hollow, thunderous notes of the drum. There is short green moss on the log where the grouse stands, and though the bird has drummed there not less than a dozen times this moss shows no sign of having been disturbed.

Banks is certain that the female is nesting somewhere near. When the hen is sitting the male bird does not wander far from the nest.—St. Paul Pioneer Press.

#### HAWK, OWL AND CROW.

I was greatly interested by articles about hawks, owls and crows in December RECREATION. Mr. Hornaday's contribution proved especially gratifying, as hitherto I had been narrow minded, holding that these birds should be exterminated. His unanswerable testimony has made a willing convert of me. It is true hawks sometimes bother the farmer considerably in the chicken season, but the occasional marauder may be picked off with a gun if too persistent.

As for the owl, so far as I can learn, in this section it confines itself for the most part to the woods, doing little damage. The crow, too, is not half so bad as painted. Of course, it is something of a nuisance in planting time, but a free use of gun and traps, or a few doses of poisoned corn, followed by a generous display of the victims, will speedily influence the survivors to a change of diet. The wholesale destruction of any creature should not be lightly entered on, as the woods and fields lose attractiveness with every specimen killed; and few species are so lacking in interest or usefulness that representatives of them are not necessary to the harmonious working of

Nature's great scheme. Keep an eye on the evil disposed ones, and when they get too numerous or too saucy, thin them out.

Mr. Mannion's experience with the wounded grouse reminds me of a similar incident that came under my notice. Two boys were hunting in a patch of woods. One fired at a grouse in a tree. It flew away, and the boy, who prided himself on his steady aim, protested, honestly enough, that he had not fired at the bird, but at some object he had mistaken for it. He changed his mind when, on returning home a few hours later, he was met by the news that a wounded grouse had flown out of the wood and taken refuge beneath a doorstep of the house, where it expired. It was undoubtedly the one he had fired at, for when last seen in the wood it was flying in the direction of the house.

John L. Woodbury, Cornish, Me.

#### BIRD NOTES.

Since my last letter to RECREATION the house wrens raised a large brood in the former abode of the bluebirds. The latter, finding themselves dispossessed, made a new nest in a flower pot a few feet higher, on a clothes post, to which I had fastened it. They raised only one bird, the other eggs being broken by accident. My purple martins raised 60 birds. Fifteen pairs had young. I average them at 4 to the pair, although some had 6 and 7, and one pair but 2.

I append a few notes made on a calendar:

August 31: Saw a flock of 2 dozen martins flying about, calling to the old birds. They usually leave August 22 to 25.

October 18: Two or 3 bluebirds about. Also saw one October 24.

October 27: Family of 6 bluebirds flying rapidly South. I presume they were an old pair and 4 young. Their loud calling attracted my attention at 6 o'clock in the morning.

November 10: Heard a bluebird calling.

A traveler informed me wild pigeons were to be found in Old Mexico. I do not think it was possible to exterminate them, as many believe was done; but believe they either migrated to Northern British provinces, or to South America. Possibly they have scattered and live in small colonies, away from civilization.

Frederick Wahl, Milwaukee, Wis.

#### PROTECTION FOR BIRDS.

Some officers in the East, becoming tired of the boldness and regularity with which the laws forbidding the slaughter of birds were defied, hit on a good plan. They raided the millinery shops and confiscated the illegal stock. The wings of the songster and the breast plumage of the feathered beauty were taken away as evidence that the statute had been violated. This method

is fair and it ought to be effective. It is no more radical than the measures applied for the protection of game out of season. When the restaurant man offers venison, ducks or quails, and the law states that he shall not have these articles in stock, he is subject to a raid, which deprives him of the forbidden articles and leads to the imposition of a fine.

The fact has been made clear that women have no sympathy with the plan of saving birds from extinction. They can not be relied on as allies in the movement, and the friends of bird life will have to take severe steps or give up the fight. As the appeal has been made to sentiment and has not excited any response, it is time for the police to be called in. Fashion, if unchecked, will exterminate the singing birds and the ones notable for the charm of their vivid coloring. As these birds are more important to the world than the style of hats, it becomes necessary to change the style of hat.—Tacoma, Wash., Ledger.

#### NATURAL HISTORY NOTES.

In October RECREATION P. P. Chase, of Ishpeming, Mich., describes a bird which he wishes to have identified. The description he gives is that of the great bittern. This bird is plentiful here, and is known by sportsmen as the green legged crane. It appears about the 1st of April and stays until October. It is seldom seen during the day, as it stays in dense swamps and feeds at night.

I think RECREATION the best sportsman's magazine. I like the way it roasts bristlebacks.

Glenn Artman, Jamestown, Pa.

How would you poison coyotes? They are numerous here, and go around in droves of 3 to 8 or 9. They do not seem afraid to go around a carcass that we have handled.

Buck Shot, Milnor, N. Dak.

Will RECREATION readers please answer?—EDITOR.

I noticed an article in a recent issue of RECREATION that reminded me of a similar occurrence. While looking for birds' eggs for my collection I saw an oriole's nest, and on climbing the tree found a kingbird hung by a horsehair around its neck. The nest was old and the bird had apparently been there a long time.

Charles Metz, Sheridan, Wyo.

This is the time to send in your subscription to RECREATION, so you will be sure to have a copy to take when you go for your hunting trip. Then you can read what the other fellows say and can compare notes with them.

Edith—Why did you refuse him?

Ethel—He has a past.

Edith—But he can blot it out.

Ethel—Perhaps, but he can't use me for a blotter.—Puck.

# THE LEAGUE OF AMERICAN SPORTSMEN.

## GENERAL OFFICERS

*President*, G. O. Shields, 23 W. 24th St., New York.

*1st Vice-President*, E. T. Seton, 80 West 40th St., New York.

*2d Vice-President*, W. T. Hornaday, 2969 Decatur Ave., Bedford Park, N. Y.

*3d Vice-President*, Dr. T. S. Palmer, Dept. of Agriculture, Washington, D. C.

*4th Vice-President*, A. A. Anderson, 80 West 40th St., New York.

*5th Vice-President*, Hon. W. A. Richards, General Land Office, Washington, D. C.

*Secretary*, A. F. Rice, 155 Pennington Ave., Passaic, N. J.

*Treasurer*, Austin Corbin, of the Corbin Banking Co., 192 Broadway, New York.

## ALASKA DIVISION.

Dr. E. M. Rininger, Chief Warden, Nome.

## ARIZONA DIVISION.

M. J. Foley, Chief Warden, Jerome.

## ARKANSAS DIVISION

W. R. Blockson, Chief Warden, Eureka Springs.

## CALIFORNIA DIVISION.

Dr. David Starr Jordan, Chief Warden, Leland Stanford University.

## COLORADO DIVISION.

A. Whitehead, Chief Warden, 303 Tabor Building, Denver.

## CONNECTICUT DIVISION.

Hon. F. P. Sherwood, Chief Warden, Southport; Dr. H. L. Ross, Vice-Warden, Canaan; H. C. Went, Sec.-Treas., Bridgeport.

## DISTRICT OF COLUMBIA DIVISION.

C. H. Townsend, Chief Warden, U. S. Fish Commission.

## FLORIDA DIVISION.

W. W. K. Decker, Chief Warden, Tarpon Springs

## GEORGIA DIVISION.

J. J. Doughty, Chief Warden, Augusta.

## IDAHO DIVISION.

L. A. Kerr, Chief Warden, Kendrick

## ILLINOIS DIVISION.

M. D. Ewell, M.D., Chief Warden, 59 Clark St., Chicago; F. M. Taber, Vice Warden, 144 Kinzie St., Chicago; G. C. Davis, Sec.-Treas., 123 S. Central Ave., Austin.

## INDIANA DIVISION.

Frank L. Littleton, Chief Warden, 30½ East Washington St., Indianapolis; J. J. Hildebrandt, Vice Warden, Logansport; T. J. Carter, Sec.-Treas., State House, Indianapolis.

## IOWA DIVISION.

Carl Quimby, Chief Warden, Des Moines; C. C. Proper, Sec.-Treas., Des Moines.

## KANSAS DIVISION.

O. B. Stocker, Chief Warden, Wichita; A. J. Applegate, Sec.-Treas., 113 E. 1st St., Wichita

## KENTUCKY DIVISION.

Geo. C. Long, Chief Warden, Hopkinsville.

R. L. Brashear, Sec.-Treas., Bowling Green.

## MAINE DIVISION.

Col. E. C. Farrington, Chief Warden, Augusta.

## MARYLAND DIVISION

J. E. Tylor, Chief Warden, Baltimore.

## MASSACHUSETTS DIVISION.

Heman S. Fay, Chief Warden, Hazleton Block, Marlboro; J. E. Tweedy, Vice-Warden, North Attleboro; A. C. Lamson, Sec.-Treas., 194 Main St., Marlboro.

## MICHIGAN DIVISION.

J. Elmer Pratt, Chief Warden, Grand Rapids; R. S.

Woolf, Vice-Warden, Jackson; A. B. Richmond, Sec.-Treas., Grand Rapids.

## MINNESOTA DIVISION.

Dietrich Lange, Chief Warden, 2294 Commonwealth Ave., St Paul.

H. A. Moigan, Vice-Warden, Albert Lea; Prof. O. T. Denny, Sec.-Treas., St. Paul.

## MISSOURI DIVISION.

Bryan Snyder, Chief Warden, 726 Central Bldg., St. Louis.

## MONTANA DIVISION.

Professor M. J. Elrod, Chief Warden, Missoula; Sidney M. Logan, Vice-Warden, Kalispell; R. A. Waagner, Sec.-Treas., Bozeman.

## NEBRASKA DIVISION.

Fred. E. Mockett, Chief Warden, Lincoln; P. O'Mahony, Sec.-Treas., Lincoln.

## NEVADA DIVISION.

Dr. W. H. Cavell, Chief Warden, Carson.

Geo. W. Cowing, Sec.-Treas., Carson.

## NEW HAMPSHIRE DIVISION.

Dr. A. F. Barrett, Sentinel Bldg., Keene,

Sidney Conant, Sec.-Treas., Keene.

## NEW JERSEY DIVISION.

Percy Johnson, Chief Warden, Bloomfield; Dr. W. S. Colfax, Vice-Warden, Pompton Lakes; I. V. Dorland, Sec.-Treas., Arlington.

## NEW MEXICO DIVISION.

P. B. Otero, Chief Warden, Santa Fe.

## NEW YORK DIVISION.

John R. Fanning, Chief Warden, Powers' Bldg., Rochester; Col. R. E. Moss, Vice-Warden, Wallack's Theatre, New York City; Dr. C. C. Curtis, Sec.-Treas., Columbia College, New York City.

## NORTH DAKOTA DIVISION.

Dr. W. D. Jones, Chief Warden, Devil's Lake.

## OHIO DIVISION.

W. E. Gleason, Chief Warden, Mitchell Bldg., Cincinnati; A. C. Thatcher, Vice-Warden, Urbana.

## OKLAHOMA DIVISION.

W. M. Grant, Chief Warden, Oklahoma City.

## ONTARIO DIVISION.

C. A. Hammond, Chief Warden, Box 701, St. Thomas; D. L. Mells, Sec.-Treas., St. Thomas.

## OREGON DIVISION.

Robert F. Kelly, Chief Warden, Box 188, The Dalles; C. B. Cushing, Sec.-Treas., The Dalles.

## PENNSYLVANIA DIVISION.

C. F. Emerson, Chief Warden, 189 N. Perry St., Titusville; Hon. C. B. Penrose, Vice-Warden, 1720 Spruce St., Philadelphia; E. Wager-Smith, Sec.-Treas., 1026 Ridge Ave., Philadelphia.

## RHODE ISLAND DIVISION.

Zenas W. Bliss, Chief Warden, 49 Westminster St., Providence.

## SOUTH CAROLINA DIVISION.

C. F. Dill, Chief Warden, Greenville.

## SOUTH DAKOTA DIVISION.

D. C. Booth, Chief Warden, Spearfish; John C. Barber, Sec.-Treas., Lead.

## TENNESSEE DIVISION.

Hon. G. C. Martin, Chief Warden, Clarksville; Hon. Austin Peay, Jr., Sec.-Treas., Clarksville.

## TEXAS DIVISION.

Prof. S. W. Stanfield, Chief Warden, San Marcos; W. E. Heald, Sec.-Treas., San Angelo.

## UTAH DIVISION.

Hon. John Sharp, Chief Warden, Salt Lake City.

## VERMONT DIVISION.

W. E. Mack, Chief Warden, Woodstock; S. C. White, Sec.-Treas., Woodstock.

## VIRGINIA DIVISION.

R. G. Bickford, Chief Warden, Newport News. C. O. Saville, Vice Warden, Richmond; M. D. Hart, Sec.-Treas., 1217 East Main St., Richmond.

## WASHINGTON DIVISION.

F. S. Merrill, Chief Warden, Spokane; F. A. Pontius, Sec.-Treas., Seattle; Munro Wyckoff, Vice-Warden, Pt. Townsend.

WEST VIRGINIA DIVISION.			County.	Name of Warden.	Address.
E. F. Smith, Chief Warden, Hinton,			Allen,	S. W. Knisely	Lima.
WISCONSIN DIVISION.			Hamilton,	W. C. Rippey,	4465 Eastern Ave. Cincinnati.
Frank Kaufman, Chief Warden, Two Rivers; Dr.			Knox,	Grant Phillips,	Mt. Vernon.
A. Gropper, Sec.-Treas., Milwaukee.			Lorain,	T. J. Bates,	Elyria.
WYOMING DIVISION.			Ottawa,	Frank B. Shirley,	Lakeside.
H. E. Wadsworth, Chief Warden, Lander; Frank			Muskingum,	Frank D. Abell,	Zanesville.
Bond, Sec.-Treas., Cheyenne.			Scioto,	J. F. Kelley,	Portsmouth.
<i>Applications for membership and orders for badges</i>			LOCAL WARDENS IN CONNECTICUT.		
<i>should be addressed to Arthur F. Rice, Secretary, 23 W.</i>			Fairfield,	George B. Bliss.	2 Park Row, Stam- ford, Ct.
<i>St., New York.</i>				Harvey C. Went,	11 Park St., Bridge- port, Ct.
LOCAL WARDENS IN NEW YORK.			Fairfield,	Samuel Waklee,	Box 373, Stratford.
County.	Name of Warden.	Address.	Litchfield,	Dr. H. L. Ross,	P. O. Box 100, Can- naon, Ct.
New York,	Conrad L. Meyer,	46 W. Broadway.	Middlesex,	Sandford Brainerd,	Ivorpton.
Livingston,	M. De La Vergne,	Lakeville.	New Haven,	Wilbur E. Beach,	318 Chapel Street, New Haven Ct.
"	K. S. Chamberlain,	Mt. Morris.	"	D. J. Ryan,	188 Elizabeth St., Derby.
"	Henry Skinner,	Springwater.	LOCAL WARDENS IN MASSACHUSETTS.		
"	Dr. J. W. Cowan,	Geneseo.	Norfolk,	Orlando McKenzie,	Norfolk.
Albany,	C. D. Johnson,	Newtonville.	"	J. J. Blick,	Wrentham.
"	Kenneth E. Bender,	Albany.	"	S. W. Fuller,	East Milton.
Broome,	John Sullivan,	Sanitaria Springs	Suffolk,	Capt. W. J. Stone,	4 Tremont Row, Boston.
"	R. R. Mathewson,	Binghamton.	Worcester,	B. H. Mosher,	Athol.
Cayuga,	H. M. Haskell,	Weedsport.	LOCAL WARDENS IN NEW JERSEY.		
Chemung,	Fred. Uhle,	Hendy Creek,	Mercer.	Edw. Vanderbilt,	Dentzville, Trenton.
"	M. A. Baker,	Elmira.	"	Roland Mitchell,	739 Centre St., Trenton.
Cortland,	James Edwards,	Cortland.	"	F. C. Wright,	Trenton.
Erie,	E. P. Dorr,	103 D. S. Morgan Building, Buffalo.	Morris,	Joseph Pellet,	Pompton Plains.
"	Marvin H. Butler,	Morilla.	"	Chas. W. Blake,	Dover.
Essex,	W. H. Broughton,	Moriah.	"	Francis E. Cook,	Butler.
Franklin,	Jas. Eccles,	St. Regis Falls.	"	Calone Orr,	Hibernia.
Montgomery,	Charles W Scharf,	Canajoharie.	Somerset,	G. E. Morris,	Somerville.
Oneida,	J. M. Scoville,	Clinton.	Sussex,	Isaac D. Williams,	Branchville.
Orange,	Wilson Crans,	Middletown.	Union,	A. H. Miller,	Cranford.
"	J. Hampton Kidd,	Newburgh.	"	C. M. Hawkins,	Roselle.
"	Thomas Harris,	Port Jervis.	Warren,	{ Jacob Young, Reuben Warner, }	Phillipsburg.
Richmond,	Lewis Morris,	Port Richmond.	Monmouth	{ Dory-Hunt, A. W. Letts, }	Wanaque. 51 Newark St., Hoboken
St. Lawrence,	Dr. B. W. Severance,	Gouverneur	Hudson,		
"	A. N. Clark,	Sevey.	LOCAL WARDENS IN PENNSYLVANIA.		
Schenectady,	J. W. Furnside,	Schenectady.	Jefferson,	John Noll,	Sykesville.
Suffolk,	F. J. Fellows,	Central Islip, L. I.	Perry,	Samuel Sundry,	Lebo.
"	P. F. Tabor,	Orient, L. I.	Warren,	F. P. Sweet,	Goodwill Hill.
Tioga,	Geo. Wood,	Owego.	"	Nelson Holmes,	Cornplanter.
Washington,	C. L. Allen,	Sandy Hill.	Juniata,	Clifford Singer,	Oakland Mills.
"	A. S. Temple,	Whitehall.	"	Ezra Phillips,	McAlesterville.
"	J. E. Barber,	Dresden.	Venango,	G. D. Benedict,	Pleasantville.
Westchester,	George Poth,	Pleasantville.	Potter,	Ira Murphy,	Coudersport.
"	Chas. Seacor,	57 Pelham Road, New Rochelle.	"	Wiley Barrows,	Austin.
"	M. W. Smith,	Croton Falls.	"	Chas. Barrows,	Austin.
"	Ralph Gorham,	Mt. Kisco	Crawford,	Jasper Tillotson,	Tillotson.
Dutchess,	} A. B. Miller,	Jackson's Corners.	"	Geo. T. Meyers,	Titusville.
Columbia,		James Lush,	Memphis.	"	J. B. Lamb,
Onondaga,	B. L. Wren,	Penn Yan.	Cambria,	W. H. Lambert,	720 Coleman Ave., Johnstown.
Yates,	Symour Poineer,	Branch Port.	Butler,	F. J. Forquer,	Murrinsville.
"	Chas. H. DeLong,	Pawling.	Allegheny,	S. H. Allen,	Natrona.
Dutchess,	Chas. H. DeLong,	Pawling.	Beaver,	N. H. Covert,	Beaver Falls.
"	Jacob Tompkins,	Billings.	"	W. R. Keefer,	"
Queens,	Gerard Van Nostrand,	Flushing, L. I.	McKean,	C. A. Duke,	Duke Center.
"	W. S. Mygrant,	46 Elton Street, Brooklyn.	"	L. P. Fessenden,	Granere.
"	P. A. Geepel,	473 Grand Ave., Astoria, L. I.	"	Wm. Holsinger,	Stickney.
"	L. B. Drowne,	119 Somers Street, Brooklyn.	Lackawanna,	Wm. Weir,	Moosic.
Ulster,	M. A. DeVall,	The Corners.	"	Wm. Major,	"
"	Wm. S. Mead,	Woodstock.	Carbon,	Asa D. Hontz,	East Mauch Chunk.
Jefferson,	C. J. Smith,	Watertown.	Cumberland,	J. C. Gill,	Mechanicsburg.
"	A. C. Cornwall,	Alexandria Bay,	Wyoming,	Cyrus Walter,	Tunkhannock.
"	Jos. Northrup,	Old Forge.	Tioga,	E. B. Beaumont, Jr.,	Lawrenceville.
Herkimer,	D. F. Sperry,	154 West Utica St.	"	G. H. Simmons,	Westfield.
Oswego,	J. E. Manning,	Mahopac Falls.	Lycoming,	Jas. J. Brennan,	Oval.
Putnam,	H. L. Brady,	Watkins.	"	B. D. Kurtz,	Cammal.
Schuyler,	G. C. Fordham,	Belvidere.	Delaware,	Walter Luson,	Ardmore.
Allegany,	G. A. Thomas,	Sharon Springs.	Montgomery,	L. C. Parsons,	Academy.
Schoharie,	O. E. Eigen,	Glen Falls.	Bradford,	Geo. B. Loop,	Sayre.
Warren,	Geo. McEchron,	E. Shelby.	Clarion,	Isaac Keener,	New Bethlehem.
Orleans,	J. H. Fearby,	Windham.	Cameron,	Harry Hemphill,	Emporium.
Greene,	W. J. Soper,	Lake Pleasant.	Clinton,	M. C. Kepler,	Renovo.
Hamilton,	David Aird, Jr.,	Massillon.	"	Geo. L. Kepler,	Renovo.
LOCAL WARDENS IN OHIO.			Northumber-land,	{ G. W. Roher, 505 Anthracite St., D. R. Lobaugh, Ely Cope, }	Shamokin Ridgway. Cadwallader.
Stark,	A. Dangeleisen,	Massillon.	Fayette,		
Franklin,	Brook L. Terry,	208 Woodward Av., Columbus.			
Cuyahoga,	A. W. Hitch,	161 Osborn St., Cleveland.			
Clark,	Fred C. Ross,	169 W. Main St., Springfield.			
Erie,	David Sutton,	418 Jackson St., Sandusky.			
Fulton,	L. C. Berry,	Swanton.			

LOCAL WARDENS IN MICHIGAN.

County.	Name of Warden.	Address.
Ottawa,	W. H. Dunham,	Drenthe.
Kalamazoo,	C. E. Miller,	Augusta.
Berrien,	W. A. Palmer,	Buchanan.
Cass,	Thomas Dewey,	Dowagiac.
Hillsdale,	C. A. Stone,	Hill-dale.
Lake,	John Trieber,	Peacock.

LOCAL WARDENS IN VIRGINIA.

Mecklenburg,	J. H. Ogburn,	South Hill.
King William,	N. H. Montagne,	Palls.
Smythe,	J. M. Hughes,	Chatham Hill.
King & Queen,	R. D. Bates,	Newtown.
Louisa,	J. P. Harris,	Applegrove.
Henrico,	W. J. Lynham,	412 W. Marshall.
East Rockingham,	E. J. Carickhoff,	Richmond.
		Harrisonburg.

LOCAL WARDENS IN WYOMING.

Fremont,	Nelson Yarnall,	Dubois.
Uinta,	{ S. N. Leek,	} Jackson.
	{ F. L. Peterson,	
Carbon,	Kirk Dyer,	Medicine Bow.
Laramie,	Martin Breither,	Cheyenne.

LOCAL WARDENS IN TENNESSEE.

Sumner,	W. G. Harris,	Gallatin.
Stewart,	John H. Lory,	Bear Spring.
Robertson,	C. C. Bell,	Springfield.
Montgomery,	P. W. Humphrey,	Clarksville.
Madison,	H. T. Rushing,	Jackson.

LOCAL WARDENS IN NEBRASKA.

Hall,	E. C. Statler,	Grand Island
-------	----------------	--------------

LOCAL WARDENS IN NEW HAMPSHIRE.

Cheshire,	S. C. Ellis,	Keene.
Sullivan,	G. A. Blake,	Lempster.
	J. W. Davidson,	Charlestown.

LOCAL WARDENS IN VERMONT.

Rutland,	Wm. J. Liddle,	Box 281, Fair Haven
Windsor,	F. A. Tarbell,	West Bridgewater.
Orleans,	E. G. Moulton,	Derby Line.
Essex,	H. S. Lund,	Granby.

LOCAL WARDENS IN ILLINOIS.

Rock Island,	D. M. Slottard,	12th Ave and 17th St., Moline.
Iroquois,	J. L. Peacock,	Sheldon.

LOCAL WARDENS IN OKLAHOMA.

Kiowa and Comanche Nation,	A. C. Cooper,	Ft. Sill.
----------------------------	---------------	-----------

LOCAL WARDENS IN IOWA.

Clinton,	D. L. Pascol,	Grand Mound.
Pottawattamie,	Dr. C. Engel,	Crecent.

LOCAL WARDENS IN WASHINGTON.

Okanogan,	James West,	Methow.
Stevens Co.,	Jacob Martin,	Newport.

LOCAL WARDENS IN UTAH.

Washington,	S. C. Goddard,	New Harmony.
	J. A. Thornton,	Pinto.

LOCAL WARDENS IN KANSAS.

Ness,	Frank Lake,	Ransom.
-------	-------------	---------

LOCAL CHAPTERS.

Albert Lea, Minn.,	H. A. Morgan,	Rear Warden.
Angelica, N. Y.,	C. A. Lathrop,	"
Augusta, Mont.,	H. Sherman,	"
Austin, Minn.,	G. F. Baird,	"
Austin, Pa.,	W. S. Warner,	"
Boston, Mass.,	Capt. W. I. Stone,	"
Buffalo, N. Y.,	H. C. Gardiner,	"
Cammal, Pa.,	B. A. Ovenshire,	"
Champaign Co., O.	Hy. F. MacCracken	"
	Urbana,	"
Charlestown, N. H.,	W. M. Buswell,	"
Cheyenne, Wyo.,	J. Hennessy,	"
Choteau, Mont.,	G. A. Gorham,	"
Cincinnati, Ohio,	B. W. Morris,	"
Coudersport, Pa.,	I. L. Murphy,	"
Cresco, Iowa,	J. L. Platt,	"
Davis, W. Va.,	J. Heltzen,	"
Dowagiac, Mich.,	W. F. Hoyt,	"
East Mauch Chunk, Pa.,	E. F. Pry,	"
Evansville, Ind.,	F. M. Gilbert,	"
Fontanet, Ind.,	W. H. Perry,	"
Ft. Wayne, Ind.,	W. L. Waltemarth	"
Great Falls, Mont.,	J. M. Gaunt,	"
Heron Lake, Minn.,	K. C. Buckeye,	"
Hollidaysbg, Pa.,	T. J. Hemphill	"
Honkinsville, Ky.,	Hunter Wood,	"
Indianapolis, Ind.,	Joseph E. Bell,	"
Jerome, Ariz.,	Dr. L. A. Hawkins,	"
Johnsonburg, Pa.,	W. J. Stebbins,	"

Kalispell, Mont.,	John Eakright,	Rear Warden.
Keene, N. H.,	F. P. Beedle,	"
Kingfisher, Okla.,	A. C. Ambrose,	"
Lake Co., Ind.,	Dr. R. C. Mackey,	"
Lawton, O. T.,	Marion Miller,	"
Lincoln, Neb.,	A. J. Sawyer	"
Logansport, Ind.,	E. B. McConnell,	"
Ludington, Mich.,	G. R. Cartier,	"
McElhattan, Pa.,	A. B. Winchester,	"
Mechanicsburg, Pa.,	Dr. J. H. Swartz,	"
Minturn, Colo.,	A. B. Walter,	"
Morgantown, W. Va.,	B. S. White,	"
New Albany, Ind.,	Dr. J. F. Weathers,	"
New Bethlehem, Pa.,	Isaac Keener,	"
Oklahoma City O.T.,	N. F. Gates,	"
Penn Yan, N. Y.,	Dr. H. R. Phillips,	"
Phillips, Wis.,	F. K. Randall,	"
Princeton, Ind.,	H. A. Yeager,	"
Reynoldsville, Pa.,	C. F. Hoffman,	"
Ridgway, Pa.,	T. J. Maxwell,	"
Rochester, N. H.,	Gustav Andreas,	"
" N. Y.,	C. H. McChesney	"
St Paul, Minn.,	O. T. Denry,	"
St. Thomas, Ont.,	L. J. Hall,	"
Schenectady, N. Y.,	J. W. Furnside,	"
Seattle, Wash.,	M. Kelly,	"
Syracuse, N. Y.,	C. C. Truesdell,	"
Terre Haute, Ind.,	C. F. Thiede,	"
The Dalles, Ore.,	C. B. Cushing,	"
Walden, N. Y.,	J. W. Reid,	"
Wichita, Kas.,	Gerald Volk,	"
Winona, Minn.,	C. M. Morse,	"

DISCOUNTS TO LEAGUE MEMBERS.

The following firms have agreed to give members of the L. A. S. a discount of 2 per cent. to 10 per cent. on all goods bought of them. In ordering please give L. A. S. number:

Syracuse Arms Co.,	Syracuse, N. Y.	Guns.
Davenport Fire Arms Co.,	Norwich, Conn.	Shot guns, rifles.
Gundlach Optical Co.,	Rochester, N. Y.	Photographic goods.
Blair Camera Co.,	Rochester, N. Y.	Photographic goods.
James Acheson,	Talbot St., St. Thomas, Ontario,	Sporting goods.

LIFE MEMBERS OF THE LEAGUE.

W. D. Ellis,	136 W. 72d street,	New York City.
A. F. Rice,	155 Pennington avenue,	Passaic, N. J.
Dr. W. A. Valentine,	5 W. 35th street,	New York City.
A. A. Anderson,	6 E. 38th street,	New York City.
A. V. Fraser,	478 Greenwich street,	New York City.
E. S. Towne,	care National Blank Book Co.,	Holyoke, Mass.
F. G. Miller,	108 Clinton street,	Defiance, Ohio.
Gen. J. F. Pierson,	20 W. 52d street,	New York City.
E. T. Seton,	80 W. 40th street,	New York City.
J. H. Seymour,	35 Wall street,	New York City.
A. G. Nesbitt,	Maple street,	Kingston, Pa.
D. C. Beard,	204 Amity street,	Flushing, L. I.
C. H. Ferry,	1720 Old Colony Bldg.,	Chicago, Ill.
Hon. Levi P. Morton,	681 5th avenue,	New York City.
H. Williams,	P. O. Box 156,	Butte, Mont.
D. B. Fearing,	Newport,	R. I.
E. H. Dickinson,	Moosehead Lake	Me.
Lorenzo Blackstone,	Norwich,	Conn.
A. L. Prescott,	90 W. Broadway,	New York City.
G. S. Edgell,	192 Broadway,	New York City.
W. B. Mershon,	Saginaw,	Mich.
Hon. H. W. Carey,	East Lake,	Mich.
George Carnegie,	Fernandina,	Fla.
Andrew Carnegie,	2nd, Fernandina,	Fla.
Morris Carnegie,	Fernandina,	Fla.
W. L. Underwood,	52 Fulton street,	Boston, Mass.
C. E. Butler,	Jerome,	Ariz.
Mansfield Ferry,	183 Lincoln Park,	Boulevard, Chicago, Ill.
Austin Corbin,	192 Broadway,	New York City.
J. Stanford Brown,	489 Fifth Ave.,	New York City.
W. H. Smith,	Bryn Mawr,	Pa.
E. B. Smith,	Bourse Bldg.,	Philadelphia, Pa.
A. J. McClure,	158 State street,	Albany, N. Y.
T. Walter Thompson,	Times Bldg.,	New York City.
Clinton Gilbert,	2 Wall St.,	New York City.
E. J. Hudson,	33 East 35th St.,	Bayonne, N. J.
Col. J. C. O'Conor,	24 East 33d st.,	New York City.

## FORESTRY.

EDITED BY DR. B. E. FERNOW.

It takes 30 years to grow a tree and 30 minutes to cut it down and destroy it.

### WIND CAVE NATIONAL PARK.

H. M. RISELEY.

Wind Cave National Park, near Hot Springs, South Dakota, is the most recent Western wonder of interest to tourists in that wild and rugged country. The bill establishing this park, which was recently passed by Congress, sets aside about 9,000 acres of land in the Black hills district of South Dakota, and confers jurisdiction of the same on the Secretary of the Interior, with full power to lease the big cavern underlying a part of the lands; also to lease portions of the lands on which buildings may be erected for the accommodation of visitors. Homesteaders who have acquired rights in this tract of land, are to be allowed to select other lands in lieu thereof, within the boundary of the State. The proceeds arising from the leasing of the cave and surrounding tracts are to be paid into the Treasury, and it is the intention of the Interior Department to use this fund in beautifying and improving the park.

These lands are of the same nature as those in the Yellowstone National Park, except that the geysers which produced the wonderful cavern underlying a large part of the Wind Cave National Park have become extinct. By constructing a dam across one of the canyons near the cave, an artificial lake can be formed, which in itself will not only aid in making the place attractive, but will afford ample water power for an electric lighting plant to illuminate the cave.

The Wind cave was first discovered in 1877, by an old character named "Lame Johnny." Johnny was one of the many who, in the early days of the Black hills, got their living by holding up the Deadwood-Cheyenne stage coach. He was afterward invited to a necktie party one night, and never lived to contest the claim of his priority to the discovery of the cave. In 1884, while a cowboy was riding through the gulch his horse became frightened, and, stopping to learn the cause, the cowboy discovered an oval shaped hole, 8x10 inches, in the bottom of the gulch, through which the wind was rushing with great force. Because of this peculiarity the cave was named Wind cave. The hole was blasted out large enough to permit entrance to the single chamber, and there the development of the cave rested until 1890, when parties located the ground as mineral claims. Men were put to work exploring and blasting out other chambers until, at the present

time, fully 100 miles of passages have been opened up and 3,000 chambers, varying in size from 12 x 12 feet to over 3 acres, have been discovered.

There are 14 different routes in the cave, but only 3 have so far been opened to the public, at an expense of \$25,000; the Garden of Eden, the Fair Grounds and the Pearly Gates. The thousands of persons who have come from all parts of the world to see this wonder pronounce it unlike anything else on the globe, differing in formation and scenery from all other caves. Geologists claim it to be an extinct geyser; and Professor Merrill, of the Smithsonian Institution, claims that the formation is unknown. There being no geological names for these formations, the guides have named them boxwood, popcorn and frostwork. Wind cave also contains the formations of other caves, such as stalactites, stalagmites, geodes, quartz and calcite crystals, and mineral-bearing rock. The cave is formed of fissures, or crevices, running parallel to each other, 50 to 300 feet apart, and connected by side passages. It has been aptly likened to a sponge. There are 8 different tiers of chambers overlying one another, some of which are large enough to enclose the Congressional Library at Washington, and most artistically decorated with ferns, grasses and feathers of pure white lime and gypsum, studded with glistening crystals of the same formation. The cavern known as the Fair Grounds is a good illustration of this. It covers more than an acre of space and is about 40 feet from floor to ceiling.

In the first of the above mentioned 8 tiers of chambers is found the water formation, beautiful, clear stalactites, or icicles, hanging from the ceiling, and some connecting with the stalagmites on the floor. The 2d tier is the frostwork, a bank of snow, composed of tiny, fine, needle-like crystals of the purest white,  $\frac{1}{4}$  of an inch to 2 inches deep. The 3d tier is the delicate boxwork, the prevailing formation of the cave. In the 4th tier the boxwork is heavier and of transparent color. The 5th is the popcorn formation. In the 6th and 7th tiers, the boxwork is still heavier, with geodes and all colors of crystals; and in the 8th tier, which is 500 feet below the entrance, the formation is heavier than anything seen before, is indigo blue in color, and dazzling to the eyes.

The cave is perfectly dry and the air pure, sweet and invigorating, especially to

asthmatic people, and retains a temperature of about 45 degrees the year around. The pure air is caused by the wind at the entrance changing according to the rising and falling of the barometer. There are places where the current of air is always in and others where it is always out. During a storm the air current is down, and in fair weather it is out, often so strong that it will nearly blow one away from the entrance. At the same time, 100 feet from the entrance the current will not blow out a candle.

At nearly every turn or angle there are crevices leading away which can be opened at small expense; and from all appearances exploration and opening of these crevices can be carried on in a moderate way for the next 10 years. None the less picturesque and grand is Crystal cave, which, like Wind cave in many respects, is found in the Elk Creek canyon of the Black hills, about 12 miles South of Deadwood. This cave is nearly as large as Wind cave, and it is believed by some that both are connected by subterranean passage ways. About 300 chambers have been opened in this cave and in the neighborhood of 50 passageways. The Black hills afford a remarkable field for geological research. In no other mountainous country can such a comprehensive idea be obtained of structural formations of the earth's surface. Deep canyons have been cut through one formation after another, thus revealing to the student the true geological conditions.

#### FOREST ADVANCE.

An interesting group of facts, involving problems of great import, is embraced in the rate at which forests in Alaska and British Columbia have been and are yet following up glacial retreat. The rate of retreat of the one and of the advance of the other are recorded in 2 ways: By the growth and advance of trees; and by the increasing depth of forest litter and humus, due to the 2, 3 or more generations of trees which have grown since the morainic *débris*, or glaciated surface, was left bare by retreating ice.

Following observations on mountains on which the glaciers were small remnants, I visited Alaska for the purpose of studying these phenomena where they are best marked in the Northern hemisphere. After careful consideration of those glaciers which would give the most reliable types and at the same time would be accessible in the short period available, Mendenhall glacier and its former bed were selected for special study. The features herein described for this locality are in general true for immense areas which were observed but not closely studied. It is true that in

some instances glacial advance has been recorded by the destruction of young and even full grown forests; but these instances evidently mark fluctuations in the general glacial retreat which is in progress. After a slight advance the retreat is again taken up, and for a limited period with greater rapidity than marks the retreat of neighboring glaciers.

Mendenhall glacier, in latitude  $58^{\circ} 25' N.$ , longitude  $134^{\circ} 30' W.$ , occupies the upper portion of a lateral channel putting off Northeasterly from the North end of Gastineau channel. The glacier once occupied the whole of this lateral channel, but has retreated until its face is now some 4 miles from the junction of the 2 channels. This lower end is now entirely filled with glacial *débris* and overgrown with alder, cottonwood, spruce, shrubs, marsh growth, etc. The lower portion of the filled area is just above tide level; the upper is about 150 feet above tide level.

The front of the glacier is some 3 miles in length and of irregular, varying height. Where long continued melting has taken place the wall of ice is only 20 or 30 feet high, and where masses of ice have recently broken off it is several times these heights.

During the 9 years preceding 1901 the retreat, as marked by a mining stake, has been at the rate of 40 to 50 feet a year. This rate of retreat is recorded for a far greater period by the forest and scrub growth which flourishes on the former bed of the glacier, and on its enclosing slopes. At a distance of about 3 miles from the present face of the glacier quite a forest of spruce trees has grown, many of which have been cut for the mines on Douglas island. Those now standing within 2 miles of the face of the glacier are nearly full grown and are evidently the only generation which has ever occupied the locality, as there are no aged or fallen trunks, and the forest litter and humus are thin and coarse. The size of one of these trees and its growth are as follows:

At	25 years	9	inches	in	diameter.
"	50	"	16	"	"
"	75	"	20.5	"	"
"	100	"	23	"	"
"	125	"	25.5	"	"
"	150	"	27.5	"	"
"	175	"	30.5	"	"
"	209	"	32.3	"	"

Other trees, not felled, were as much as 8 or 10 inches larger in diameter, but the one measured was about an average.

Advancing from  $\frac{3}{4}$  to one mile toward the glacier, few trees could be found over 20 inches in diameter, or about 70 to 80 years old. Within the next  $\frac{1}{2}$  to  $\frac{1}{4}$  of a mile the trees had decreased in age to saplings 6 to 8 inches in diameter or about  $\frac{1}{4}$

of a century old. Beyond these were young and seedling spruce, which soon gave out entirely, their places being taken by alder brush, dwarf cottonwood, grasses and mosses. The surface between these and the glacier was composed of clean boulders, gravel and sand, showing but slight signs of disintegration and supporting no growth except mosses.

The forest record and data available for study from the Puget Sound region to Yakutat bay are highly instructive, not only to the students of forestry, but to those of geology and climatology.—Marsden Manson in the *Forestry Quarterly*.

#### NATURE NEEDS PROTECTION.

Few men realize how important the questions of game and forest preservation have become. Today we face a great danger and scarcely realize it, though every person in our country feels, directly or indirectly, the effect of the terrible destruction.

Our Western prairies are now the home of millions of cattle. Once herds of buffalo, or bison, were without number on these same plains. In the river valleys we see large fields of grain, and vineyards, and orchards, where a generation ago was a dense growth of forest. Such has been the advance of the new civilization into our natural wealth and treasures that we have drawn too heavily. Nature grows weak. Would La Salle have believed the great forests of his day could ever be so depleted?

That we have fabulous wealth to show for this destruction, is the defense some put forward. True, our wealth is great and our resources are still enormous; but we must not wait for our fortunes to fall in ruins before we act. A wise man builds carefully rather than hastily. We are warned by the terrible floods of the last few years to desist. The depletion of our forests has made these floods possible. These warnings have been emphasized by the wind storms and tornadoes.

New blights have smitten our crops, new worms swoop down and destroy the vegetation. These are scarcely new, save in their strength, but now they center their energies in the cultivated fields instead of on the wild vegetation. We have cleared away the wild creations and planted our own choice.

We were made lords and masters of the world to improve, not to ruin it. Discrimination is necessary to any successful business. We must discern which to leave of our timber, which to destroy. Cleared ground is obviously a necessity; but is it required of us to waste the timber that is cleared away? We could often see, a few years ago, possibly now, large tracts of land with tree trunks lying prone on every

acre; not a few crooked logs, but a whole forest of straight, good timber. This was "new ground." Or else there stood a dead, blighted army of primeval giants. A ring had been chopped around each trunk. Again we saw the "new ground."

We have grown more careful, but still there are many who are reckless. Our forests are our protectors, our reservoirs for moisture, our safety from winds, our pleasure for relief from the naked fields.

The game birds and beasts have their homes, generally, in the forests. Our rivers are dependent on the trees, our fishes are dependent on the purity of these rivers. Legislation must be made to protect our forests, and such laws must be enforced. Who is to be the leader in this movement? Who will center his energies in such a grand undertaking?

How can we plead for our game? How defend the weak? Chivalry teaches us to defend a woman because she is weak. A deer, with its helpless, startled eyes, pleading for a home, deserves protection. The lives of the hunted must be indeed unhappy. Fierce hawks and eagles swoop down on the rabbits and hares, the owl comes in the dark of the night and kills; but worse than these are the men who come with their guns. Where can the birds go? To fly is to plunge into the faster flying bullet; to stay is surer death. Where can they hide? The fields are open corn or stubble; the forests are scant protection. Here, again, we need laws, that are enforced.

Can anyone say that a park made by man is more beautiful than a forest? Aside from the necessity of our forests we have the pleasures they give us. The dwellers in our forests are interesting and necessary. To study the habits of the birds and beasts is to admire them. The cunning of some, the ingenuity of others, and the innocence of most of them appeal to us. We are told to go to the ant for wisdom, but it would be good to take a post-graduate course in the forests. There the busy bee is found, the warlike hornet, the cunning fox, the guileless squirrel, the crow, the raccoon and innumerable representatives of our wild friends.

The coming generations will curse us if we deprive them of the forest and animal world. It is our duty to preserve some of the beauties for posterity. To doom them to a habitation of iron and steel and glass is unfair. There is hope; there is still time to act. People are becoming interested in Nature. Let us all encourage this interest.

Thos. H. W., Kyle, W. Va.

Legislation has been passed appropriating \$5,000 to establish a forest nursery in connection with the Agricultural College, for the purpose of distributing plant material.  
—EDITOR.



## PURE AND IMPURE FOODS.

*"What a Man Eats He Is."*

Edited by C. F. LANGWORTHY, PH.D.

Author of "On Citraconic, Itaconic and Mesaconic Acids," "Fish as Food," etc.

### FOOD OF THE JAPANESE.

Professor Kintaro Oshima, of the Imperial College, Sapporo, Japan, has spent considerable time in this country studying problems connected with food and diet, and intends to continue this line of work in his own country. Such investigations are by no means unknown in Japan, and while in the United States Professor Oshima devoted a good deal of his time to collecting and systematizing the results of Japanese investigations for the use of the United States Department of Agriculture.

The data collected represent the results of investigations made by the army and navy of Japan at the Government laboratories, and by investigators at the Japanese universities. Most of the material was in printed form, some of it being in Japanese, some in German, and some in English and French. The memoranda regarding experiments made in the army and navy were in manuscript. It would seem desirable to have the work printed in English that it may reach a larger class of students who are interested in this question.

One of the most interesting portions of the compilation, Mr. Oshima states, will relate to the comparative nutritive value of rice and barley. Many experiments have been made in the Japanese army and navy, especially to demonstrate which of these 2 foods would be the better ration for the soldiers and sailors.

Formerly rice was one of the principal articles of food for the army and navy. About 36 per cent of the marines of Japan were afflicted with beri-beri, a disease which is caused by a diet that is not well balanced. It was found that there was not a sufficient quantity of protein in the diet of the soldiers and sailors for a proper nourishment of the body. The question of substituting barley for rice was then discussed and experiments were made. These experiments showed that although barley contained more protein, its nutritive value as a food was not so great as that of rice. A complete change in the rations for the army and navy was then made. Meat and fish were generally introduced into the diet of the men and a substitution of bread for part of the rice was made. With that change in rations came a decided improvement in the condition, the efficiency and the health of the soldiers and sailors, and beri-beri rapidly disappeared.

An erroneous impression prevails, due principally to the writings of those who are superficially informed on the subject, that the Japanese people subsist mainly on rice;

indeed, that rice is about all they eat at all their meals. This is radically wrong, according to Professor Oshima, and at absolute variance with the conditions as they actually exist in that country, as well informed persons should know. Travelers through Japan fail to realize that the laboring classes have their principal meal at night, when their hard day's work is finished. They are then away from the observation of these travelers, who do not see their meal. Vegetables form a large part of Japanese diet, especially of those who live in the rural districts, away from the fresh fish districts. Meat is not used by the lower classes a great deal, because of its high price, in the first place, and because it is almost impossible to get it at any price, except in the cities. The different preparations of beans are consumed in large quantities. Fish is abundant and is eaten in large quantities, its nutritive value being about as great as that of meat. The quantity of meat consumed in Japan yearly is slowly increasing, but not at the rate that it is increasing in European countries. Of course, the quantity of meat eaten in Japan does not compare at all with that consumed in the United States.

The Japanese use no ranges for cooking purposes; simply fireplaces. The adoption of bread for a food would require a large expenditure of money for the reconstruction of their fireplaces or kitchens, and that is a financial outlay that the poorer classes of the Japanese can not stand. The result of all the investigations concerning the diet of the Japanese seems to indicate that there should be an increase in the quantity of protein in the Japanese food. This can be brought about by the use of more fish and more beans by the working classes. The rich people will use meat, but this more expensive food may or may not insure more nutritive value than a plainer fare. The tendency seems to be toward the too restricted use of foods rich in protein, but it is hard to lay down a fixed rule for the best form of diet for the different people of diverse classes and countries.

### NON-NUTRIENTS IN FOOD.

It is interesting to consider some of the differences in food materials as shown by their chemical composition. All foods are made up of the nutrients, protein, fat, carbohydrates and ash, in addition to water, which is not a nutrient, though it is essential.

Food, as we buy it in the market, or even

as it is served on the table, contains more or less material which we can not or do not eat, and which would have little or no nutritive value if we did eat it; such, for instance, as the bones of meat and fish, the shells of eggs, and the skins and seeds of fruits and vegetables. In discussing the chemical composition of foods such portions are usually counted as refuse, but they make an important item when we consider the actual cost of the nutrients of food. The materials grouped together as refuse contain in part the same ingredients as the edible portion, though usually in different proportions. Thus, bones are largely mineral matter, with some fat and protein; egg shells are almost entirely mineral matter; bran of wheat has a high content of fiber, or woody material. Vegetable refuse is characterized by a high content of these latter constituents. In some cases material which is edible is classed as refuse because the flavor is objectionable. Thus peach and plum pits are too highly flavored to be agreeable if eaten in quantity, and are thought to be actually injurious.

One of the first things which becomes evident when foods are studied in respect to their chemical composition is the differences in the proportions of non-nutrients, *i. e.*, refuse and water in them. Many kinds of food, as they are purchased, contain large quantities of refuse, which, while found in meats, fish, eggs, fresh vegetables, and fruit, is usually absent in the dairy products, milk, butter, cheese, etc., dried vegetables, cereal foods, flour, breakfast foods, etc., and the bread, cakes and other foods prepared from them.

In considering the edible portion we find that the quantity of water present also affects the nutritive value of food. Water is necessary to the body, and it is usually supplied in abundance by beverages, although the quantity contained in the solid food consumed in a day is considerable. Water forms 40 to 50 per cent of the ordinary cuts of meat. It is especially abundant in the flesh of lean animals, and tends to decrease as fat increases, and vice versa. It is even more abundant in fresh fish than in meats, but in dried fish there is, of course, comparatively little. Fresh vegetables and fruits contain sometimes as much as 80 or 90 per cent or more of water, while dried beans, peas, meals, flour, cereal breakfast foods, etc., usually contain 10 to 12 per cent of water. Many cooked foods contain more water than the raw materials from which they are made, owing to the quantities added in cooking. Thus some thin soups are little more than flavored and colored water, and of course have an extremely low nutritive value. In other cooked foods, notably meats, which have been baked, roasted or fried, the water is diminished by cooking.

## TWO CENTURIES AGO.

Some information regarding the foods eaten and the cost of living, 200 years ago, is furnished by the entries in an old account book recently described in one of the English reviews. The writer was evidently an Englishman living in Surrey near Godalming.

"We can picture the living in those days from the cost of the items in these little pages. The house must have been dark at night, with candles at 5 shillings and 2 pence a dozen and 'oyl' a shilling a pint; and people sat around the one light in the long evenings, for there is 'For mending ye lanthorn rod.'; and the frequency of 'For Worsted, 6d.' shows that the only possible thing to do was to knit. Rushes and sand must mean that these covered the floor, and as they cost a shilling each time, they were as lavishly used as was decorous in the house of a man of quality. 'A Tub of Sope 9s. and 6d.,' and again '4 dozen of Sope 8 shillings,' are suggestive items; but people did their own washing, for starch is entered fairly often. They brewed their own ale, too, for there is a separate page devoted thus: 'Anno Dom. 1709-10 an account of what malt I have had of Mr. Otway of Godalming.' They must have made cowslip wine, for there stands the entry of payment for the cowslips and 1s. 6d. 'for a grose of corks.' We can find out what dinners they ate in 1709, for it is all down neatly. Vegetables are the largest items. 'Turneps, cowcumpers, carrots, onions' are almost daily; pears by the bushel, and cheese by the 100 weight; 'For 100 weight of cheese, £1.8.0. For ye carrying of it home, one shilling.' Eggs, currants, lemons, and oatmeal appear in quantities; anchovies and capers, and many chickens. Goody Francis was paid 5s. 6d. on May 20, 1709, for 11 chickens, and Goody Ford had 8s. 6d. for 17 pounds of butter. A pheasant was 1s., 2 woodcocks cost 10d., and 200 heads of asparagus 1s. 6d.; but 'Collyflowers' were dear at 11d. for 2, in days when a yoke of oxen cost £10. Meat is not often mentioned, but when bought it is in such large quantities that it must have been for salting: 'Feb. 6, 1710, To Quennell ye butcher of Chiddingfold for 15 stone of beef, £1.7.6.' 'Mackerell' was bought once, salt fish at 4s. 6d., and 200 oysters at 2 shillings; and once they paid 1s. 6d. for prawns, but how prawns got to the neighborhood of Godalming in those days is past finding out. It is incomprehensible also why 10 shillings was paid Goody Mellersh for 28½ pounds of clover, and why they bought 'poppies.' Sugar is only mentioned once, for it was a great luxury; also mace and nutmegs, which cost 2s. 9d.; and tea is mentioned only once."

## BOOK NOTICES.

### A GOOD BOOK ON GAME BIRDS.

Any man with sporting blood in his veins will be delighted with "Our Feathered Game," which describes, pictures and gossips agreeably about 135 species of birds, yet is small enough to be carried comfortably in any hunter's gripsack. Mr. Huntington's delightful book represents a nail hit squarely on the head, both by author and publisher. The subject has been well covered and well illustrated, with a good figure of every species mentioned, in a single volume of handy size.

The figures are small, usually 6 on a page; but they are clear cut, beautifully printed and thoroughly useful in the identification of species. The colored plates are mostly too yellow or too brown; and that opposite page 258 looks too much like some of the awful colored plates in some of the great magazines. The one facing page 85, "Shooting Sage Grouse," is all right. Mr. Huntington is particularly successful with pictures of the sage brush plains.

This book is not a dull and deadly catalogue of species. Much of it is good reading, and the many incidents of the hunting field are grateful and comforting. The technical names and descriptions are wisely relegated to the back of the book, so that the real reader has plain sailing through 346 pages.

Of the few little things which might be criticized, the most serious is the author's official acceptance of doves, 7 species in all, as game birds. It matters not that in California, the South, and in a few other localities, doves are killed by men who otherwise are sportsmen. We have "in our midst," unfortunately, thousands of Italians who kill robins, orioles, thrushes and other song birds generally, as game, for the pot! But all the killing that ever has been or ever will be done can not make doves or song birds into real game birds. Doves are too tame to be game; and first, last and all the time, true sportsmen protest against doves being classed with the birds that may be shot and eaten. Let us draw the line above them.

W. T. H.

**OUR FEATHERED GAME:** A Handbook of the North American Game Birds. By Dwight W. Huntington. Cloth, 8vo, 47 full-page plates, 8 in color, pp. 396. New York: Charles Scribner's Sons.

### A BIRD LOVE STORY.

"The Song of the Cardinal," by Gene S. Porter, is a bird story written from the heart. Mrs. Porter is well known to readers of *RECREATION* as a contributor, as a

lover of nature, and as an enthusiastic amateur photographer. With loving observation she tells of the red bird's wooing in rapturous and tender love song; of his devotion to his shy little bride, to whom he sings, "So dear, so dear;" of his mad delight in the advent of his small family, which he announces to the world with a wild, triumphant "See here! See here!" and of his valiant daily life. Mrs. Porter's wish is that her book shall inculcate a love of birds. If in a few instances she has sacrificed accurate natural history to the popular conception of bird life, she has not done more than some of her predecessors have been charged with.

The illustrations are reproductions of photographs taken by Mrs. Porter of the wild, free birds in their own homes. It is safe to say that each photograph represents days if not weeks of toil and lying in wait among the haunts of the birds; work which might well daunt many a man. The photographs are accurate portraits of the birds, for Mrs. Porter has not permitted a feather to be touched, either on the negatives or in the prints.

"The Song of the Cardinal" is handsomely made, is published by The Bobbs-Merrill Co., Indianapolis, and the price is \$1.50.

"The Training of Wild Animals" is a most fascinating book, by Frank C. Bostock, the well-known trainer, who has spent his life with wild beasts. He tells how and why he undertook the work; the history of wild animal training; how wild animals are captured; what are the essentials for the care of animals; what traits a man must have in order to become a successful trainer; the characteristics of different animals; and how some animals go bad and can never again be exhibited or trusted. He describes in detail the principles and processes of training, and many accidents which have occurred to trainers, explaining the causes of trouble in each case; and he most generously gives great credit to other famous trainers, some of whose experiences he relates, in graphic and interesting style.

The book contains 32 attractive half-tone illustrations, is edited by Miss Ellen Velvin, F.Z.S., herself a well-known writer of animal stories, and is published by The Century Company, New York. Price, \$1.

"Homophonic Conversations," in English, German, French and Italian, is a small book intended as a natural aid to the memory in learning those languages. It is arranged

in parallel columns, which give an instantaneous view of the same sentence in the 4 different languages. The sentences, or conversations, are selected on the basis of similarity of sound between the languages; for instance, "Will you have coffee?" "Wünschen Sie Kaffee?" "Voulez-vous du café?" "Volete del caffè?" The vocabulary is well chosen to serve most urgent needs, and the system makes it nearly as easy to learn 4 languages as one. The book is invaluable to any traveler in Europe or to anyone wishing to acquire a working knowledge of any or all these languages.

Compiled and published by C. V. Waite & Co., 479 Jackson Boulevard, Chicago; price, \$1.

The Forest Fish and Game Commission of the State of New York has issued a publication entitled "Tree Planting on Streets and Highways." This volume has been compiled in response to the many inquiries received by the Commission relative to tree planting, and is intended to aid those who wish to beautify the streets and roads of their localities, but who have not the knowledge necessary to the work. It tells what trees to plant, under different conditions, and in order to obtain varying effects; when and how to plant them. It also gives synopses of the laws of different States in regard to tree planting.

The book is illustrated with 28 half tone engravings and 8 exquisite colored plates. Further information regarding it can be obtained by writing the State Forest, Fish and Game Commission, Albany, N. Y.

The Association for the Protection of the Adirondacks has issued a pamphlet setting forth reasons why these lands should be acquired, preserved and reforested by the State of New York. The pamphlet gives a sketch of the origin, the romantic charms and the practical uses of the Adirondack park, and is intended to increase public interest in this beautiful region.

Copies of this pamphlet will be sent gratuitously to any person sending address to the Association's Headquarters in the Tribune Building, New York City.

"The Tale of the Phantom Yacht," a poem by Bingham T. Wilson, is published in the form of an attractive booklet, by the Cornell Publishing Company, New York. The tale is an allegory, as told by the Commodore of the New York Yacht Club, and the booklet is dedicated to Sir Thomas Lip-ton.

Mr. Wilson will be remembered by readers of RECREATION as the author of "Bob White," a Christmas poem published in the December, 1902, issue of this magazine.

## PUBLISHER'S NOTES.

Bausch & Lomb Optical Co., Rochester, N. Y., announce the 50th anniversary of the business association of Mr. I. I. Bausch and Mr. Henry Lomb, who are still active in the management of the company. To commemorate this semi-centennial they have issued an exquisite souvenir pamphlet setting forth the most important facts in connection with the development of the company. This history plainly shows that the chief aims of these manufacturers, from the beginning of their business career, have been to make the finest possible goods, to welcome and avail of every new idea that presented itself for perfecting their goods, to meet always the severest requirements of the trade, and to spare neither effort nor money in placing their lenses, photographic and optical goods in the front rank of the world.

Starting with the labor of their own hands, in a small shop, they now employ 1,200 people, in immense factories in America and Germany, and produce an enormous output.

A map of the lake region of Northern Wisconsin and Michigan has just been is-

sued by the passenger department of the Chicago & Northwestern Railway, in pocket form. The map shows lakes, streams, wagon roads, trails, artificial channels, portages, camps, club houses, towns and railway lines in one of the best hunting and fishing regions in the world.

This map will be sent to any address fully paid on receipt by the passenger department of the Chicago & Northwestern Railway, Chicago, of 10 cents in stamps.

This company has also issued a pamphlet entitled "Colorado," which is a complete guide to the magnificent scenic attractions of that State. The pamphlet contains many illustrations from photographs, and can be obtained on application to the passenger department of the C. & N. W. R'y., Chicago.

The Du Pont Powder Co., of Wilmington, Del., has issued one of the most beautiful books ever printed by any manufacturer of sportsmen's goods. It contains a series of full page drawings by some of the best artists in the country on such subjects as the gray squirrel, the rabbit, the woodcock, the plover, the ruffed grouse, the wild turkey and the canvasback duck,

which are real gems of art. These drawings are well worth cutting out and framing, and I have no doubt thousands of sportsmen who get copies of the book will do this.

The text is of an exceedingly interesting nature, and at the same time it contains much practical information for sportsmen. Every man should have a copy of the Du Pont book. In writing for it, please mention RECREATION.

These letters are samples of the many received by the Life Saving Folding Canvas Boat Company:

Dear Sirs:

I have given your keel a good test and it has proved satisfactory in every way. I recommend it to any one who wishes a safe and reliable keel. Respectfully yours,

Joe Hyman, Kalamazoo, Mich.

Dear Sirs:

I have put the 12 foot special boat received of you to thorough tests and am pleased to find it perfection in every way, combining neatness of appearance, convenience in setting up, and ease of management on the water. Respectfully,

G. K. Snow, Ventura, Cal.

If you get a deer head or an elk head on your hunting trip this fall, where will you have it mounted? Why not mount it yourself? The Northwestern School of Taxidermy will teach you how, by mail. This school gives complete instructions that will enable you to mount your fish, game and bird trophies in natural, artistic style, thus adding tenfold to your pride, interest and pleasure in the possession of the prize.

Write the School for free descriptive circular, and please say you saw their ad in RECREATION.

The Baker Gun Quarterly is a periodical published by the Baker Gun and Forging Co., of Batavia, N. Y., which is always well filled with interesting matter relating to the Baker gun. The publishers also print in this journal a good deal of information as to shooting and necessary equipment for the field. You can have your name placed on the mailing list for the asking.

In writing, please mention RECREATION.

The Bradley shot gun sight is a new invention so simple and effective that it makes wing shooting easy and certain. It is invaluable for beginners, and even expert wing shots will be surprised at its effectiveness. The sight is instantly attachable and detachable to any gun and does not mar the barrel.

Write C. D. Bradley for copy of descrip-

tive circular, and please say you saw the ad in RECREATION.

New York.

Messrs. Wing & Son:

It gives me much pleasure to say that we have given the Wing piano a thorough test in our orchestra and it has given us entire satisfaction. Our leader states that he finds it most satisfactory both in brilliancy and resonance of tone.

M. Stockham,  
Proprietor Criterion Hotel.

Chappell Hill, Tex.

Northern Rubber Co.,  
St. Paul, Minn.

Gentlemen: I am well pleased with the Banner rubber coat. It is just what I have been wanting. Would not part with it for twice the amount I gave for it.

Yours truly,  
I. K. Morris.

Mr. S. M. Van Allen, of Jamaica, L. I., won the New York State Championship Cup with a score of 91 out of 100; the 100 iBrd Amateur Championship Diamond Medal with a score of 93 out of 100, and the Individual Average Amateur Championship Gold Medal with an average of 92 per cent. All these were won with a Charles Daly gun.

The Century Camera Co., Rochester, N. Y.

All goods we have bought of you have been extremely satisfactory and have taken well with our trade. In your Century Grand you have the finest folding camera now on the market.

Thomas H. Leiber Co., Indianapolis, Ind.

We have been getting excellent results from our 2 page ad in RECREATION, and many people have written us that anything Shields recommends or advertises in RECREATION is good stuff. We want no better recommendation than this.

Multiscope & Film Co., Burlington, Wis.

Augusta, Georgia.

West End Furniture Co.,

Dear Sirs:—The gun cabinet arrived safe and it is a beautiful piece of furniture.

Respectfully,  
Owen O. Moore.

RECREATION continues to grow in favor and popularity in Tacoma, and each month I notice higher stacks of them at the different news stands. I have also heard of many of your books hereabouts, particularly "Cruisings in the Cascades," which I hear highly commended.

Meriden S. Hill, Tacoma, Wash.

## EDITOR'S CORNER.

### A FEARLESS GAME WARDEN.

In April last, Deputy Game Warden Brewster, of Grand Rapids, Mich., seized and confiscated 224 deer skins, and 21 beaver skins at Sault Ste Marie. Warrants were issued for the owner of the warehouse where the skins were found and for several men who were charged with having killed the game. Some of these men have been tried, convicted and punished, and actions against others are pending.

While Mr. Brewster was looking up the evidence in this case he found 51 deer carcasses within a small area in Chippewa county. In view of the vigorous and effective work which has been carried on by the Michigan State game warden and his deputies for several years past it is interesting to guess what would be done in Michigan if there were no such men as Morse and Brewster in office. The latter has made himself so exceedingly unpopular among the enemies of game protection that they induced the Legislature at its last session to enact a law abolishing the office of chief deputy game warden; but in response to vigorous protests from thousands of sportsmen Governor Bliss vetoed the bill. Mr. Brewster is still in the saddle and I trust he may be retained there until the last game hog in Michigan shall be rounded up and put behind the bars.

### BIRDS NEED MORE FRIENDS.

RECREATION and the L. A. S., aided by the Audubon societies and certain influential journals, have nearly abolished millinery traffic in the skins and plumage of song and insectivorous birds in this country. In Europe, however, the infamous business still goes on without hinderance. Last year there were 6 auctions of feathers and bird skins in London, at which 1,688 packages of feathers were sold. Each package weighed about 30 ounces, making a total of 50,640 ounces, and it is estimated that 4 birds were required to furnish each ounce of plumes, or other feathers. These sales therefore represent the slaughter of 202,560 birds, and all for the purpose of decorating the headgear of vain, thoughtless, soulless women. The birds are collected in various parts of the world, and no doubt many of them in the Southern United States, the plumage being smuggled out under false labels.

There is yet a great deal of important work to be done by the friends of the birds, even in this country, before the slaughter can be entirely stopped. We are making progress every day, but we need the co-operation and the financial support of

thousands of other men and women in our work.

Chris. McLain, his son and 3 other men were spearing fish in a lake near Frankfort, Mich., one night in April last, when game warden B. B. Spafford, of Cadillac, raided them and ordered them to surrender. McLain attacked Spafford with a spear and pinned him to the earth, when Spafford drew his revolver and shot McLain dead. Darkness prevented the identification of the men who were with McLain, but it is safe to say they will do no more spearing, for a while, at least. Spafford was arrested, but when the facts became known he was promptly released. He should now be promoted as a reward for his efficiency.

Another dynamiter has got what he deserves. This time it was Edward Vandeventer, of Mound City, Mo. He had been dynamiting fish in Big lake, 7 miles from that city, for some time past and selling them in the market. March 23rd, while he was handling dynamite, a cartridge exploded prematurely. Both his arms were blown off and both eyes put out. He died a few hours later. It is some satisfaction to know that occasionally these infamous wretches gets a dose of their own medicine.

Geo. Phinney, of Sutherland, Iowa, was arrested by a State game warden some weeks ago on the charge of violating the game law, and 42 prairie chickens were found in his possession. I have always supposed that game law violators belonged to the genus *Swinus*, but it seems this one belongs to the Phinney tribe. Hereafter, George will no doubt be glad to eat domestic chickens, and let the wild ones alone, at least in close season.

C. G. Eberline, of Wells, Minn., was shot and killed while in his boat, some weeks ago, by a fish pirate who nets fish in season and out of season regardless of laws. It seems he imagined that Mr. Eberline had been instrumental in putting the officers of the law on his trail, and took that method of wreaking vengeance on his alleged accuser. Fortunately the man who did the shooting was arrested and is now in jail awaiting trial for murder.

Geo. H. England, of Holyoke, Mass., was arrested some weeks ago for having killed 3 ruffed grouse in violation of law. He was taken before Justice Strickland, who fined him \$20 and costs. Probably England did not feel so big as his name after settling with the court.



THE BEER  
THAT MADE  
MILWAUKEE  
FAMOUS

**The yeast in  
Schlitz Beer  
never changes**

Beside purity, there's nothing more important in beer than the yeast.

We experimented for years to get a yeast that was right—a yeast that would give a better flavor than any other beer had.

When we got it we saved the mother cells. And all the yeast used in Schlitz Beer from that time, and forever, is developed from those original cells.

**But its best  
goodness  
is purity**

Drinking Schlitz Beer means drinking good health.

Not another beverage which you drink is so carefully made. We even filter all the air that touches it, and sterilize every bottle after it is sealed.

Yet the price of common beer buys it.

*Ask for the brewery bottling.*

## QUEBEC IN WINTER.

E. M.

Early last summer I told an ex-resident of Quebec that I expected to visit his native city.

"Not in summer!" he expostulated.

"Why, of course!" I replied. "Isn't that a good place to keep cool in?"

"Oh, yes," he answered indifferently, "but the time to see Quebec in her real glory is winter."

I gasped, and shivered with apprehension.

"Not at all," insisted the man from Quebec. "People in Quebec do not suffer so much from the cold as we do here in New York; and they enjoy life in winter more than they do in summer. The air is dry, pure and bracing. It does not carry the deadly chill of damp sea air. On the contrary, it inspires activity and gaiety. If you expect to see Quebec in characteristic mood, defer your visit until next winter."

I followed his advice, for why spend time and money to see a place except at its best?

I reached Quebec in the evening, and my first impressions of that beautiful, historic and most interesting city gave me a new thrill. Seated in a curious little cariole and wrapped to my chin in soft fur robes, I was driven swiftly through the quaint streets, sometimes between high, foreign-looking stone walls topped with massive buildings, to the Château Frontenac, most picturesque and beautiful hotel in the world. The artistic and exquisite interior, softly warm, was glowing with lights, and suggested rather a uniquely beautiful home than a mere hostelry. The room to which I was shown confirmed the impression; not a square, formal, sepulchral hotel room, but a dainty boudoir of artistic coloring.

I turned to a window, and before me was a vision of the glory of winter. Far down below, the majestic St. Lawrence wound to meet the sea; the earth lay quiet beneath a downy cover of snow; long rows of lights on both sides of the river sparkled and snapped with dazzling brilliancy; and above all rose the moon, bathing the scene in white splendor! I was more than ready to bend my knee to the Frost King!

It is in Quebec in winter that sport is truly royal. Then the native population gives itself up to those forms of social and physical enjoyment which are the more characteristic of its picturesque life and environment. Then, too, the atmosphere is at its purest and best, and defies insomnia, malaria and all diseases of the respiratory organs. Instead of the enervating climate of the South that makes exertion of every kind a burden, physical exercise in Quebec during the season of frost and snow is a positive pleasure. The more one walks or skates or drives or tramps on skis or snow shoes, the more temptation there is to repeat the experience. The bracing air of the Canadian winter is the elixir of life, *ennui* and enervation giving way to exhilaration and health. The lungs expand to the enormous inhalations of oxygen, and

the purified and brightened blood courses more freely and invigoratingly through the veins. Clad in raiment befitting the climate, with *ad libitum* accompaniments of the beautiful furs that are there so fashionable and so comparatively inexpensive, discomfort is unknown, and luxury and exhilaration are the order of the day. The blood tingles with a vigorous sense of pleasure and delight that is unknown in lower latitudes, and that inspires a desire for active participation in out of door exercise and the prevailing sports and pastimes of the people. These are at the same time picturesque, attractive and rational. Strangers who wish to participate therein are warmly welcomed by the different winter clubs and quickly initiated into the various forms of local sport. Skating on the various rinks is continuously in progress there during the winter. There are both indoor and outdoor rinks to which guest tickets of admission may be had by non-residents for the asking, and the fancy skating daily witnessed there is alone well worth a long journey to see.

The most exciting winter game of Quebec is hockey, which, with the possible exception of polo, is the fastest known to lovers of athletic sports. There are often 2 or 3 matches a week. Quebec has 2 curling rinks and many lovers and excellent players of the roarin' game. Tobogganing down the hills of the Cove Fields that form part of the historic Plains of Abraham is a favorite amusement with Quebecers and a thrilling experience for visitors. This toboggan slide is one of the greatest in the world. The daring tobogganers start from immediately under the Citadel, speed down the Glacis, and run until the toboggan reaches the other end of the beautiful Dufferin Terrace. This scene at night, with the picturesque club uniforms, under the many lights, can not be surpassed. Sleighing is also fashionable amusement in Quebec, and the roads round about the city are kept in excellent condition. In the streets of the city hundreds of carioles, queer little sleds peculiar to this quaint old place, dash along, their jingling bells filling the air with silvery music. The various snowshoe clubs contribute largely to the social life and enjoyment of Quebec in winter. Their long night tramps to their country rendezvous are often headed by a bugle band, and they present a highly picturesque appearance tramping in Indian file over the snow, clad in their multi-colored blanket suits and bearing torches. Skiing is also a fashionable source of amusement, and is yearly growing in popular favor. The use of the ski is easily learned, and with a little practice the beginner soon becomes a skilled skier. During January and February a good sport is obtainable in fishing for tommycods through the ice of the St. Charles river, where *cabanes*, or huts, comfortably heated, are erected for the purpose.

The winter visitor leaves Quebec reluctantly, vowing to return when the world elsewhere shall become too tame for him.



# THE EQUITABLE



J.W.ALEXANDER  
PRESIDENT

J.H.HYDE  
VICE PRESIDENT

HENRY B.HYDE  
FOUNDER

## THE FRUIT

of your foresight now  
may be gathered just  
when you need it, if you  
take an Endowment in  
the Equitable Life Assur-  
ance Society.

And meanwhile your  
family is protected.

*Vacancies for men of character to act as representatives*

Apply to GAGE E. TARBELL, 2<sup>ND</sup> Vice President

For full information fill out this coupon, or write  
THE EQUITABLE LIFE ASSURANCE SOCIETY of the United States  
120 Broadway, New York Dept. No. 16

Please send me information regarding an Endowment for \$.....  
if issued at.....years of age.

Name.....

Address.....

## AMATEUR PHOTOGRAPHY.

"For sport the lens is better than the gun."

*I wish to make this department of the utmost use to amateurs. I shall, therefore, be glad to answer any questions and to print any items sent me by practical amateurs relating to their experience in photography.*

### 8th ANNUAL COMPETITION.

RECREATION has conducted 7 amateur photographic competitions, all of which have been eminently successful. The 8th opened April 1st, 1903, and will close November 30th, 1903.

Following is a list of prizes to be awarded:

First prize: A Long Focus Korona Camera, 5 x 7, made by the Gundlach Optical Co., Rochester, N. Y., fitted with a Turner-Reich Anastigmat Lens, and listed at \$85.

Second prize: A No. 3 Folding Pocket Kodak, made by the Eastman Kodak Co., Rochester, N. Y., fitted with a Bausch & Lomb Lens, Plastigmat Unicum Shutter, and listed at \$61.50.

Third prize: A Royal Anastigmat Lens, 4 x 5, made by the Rochester Lens Co., Rochester, N. Y.; listed at \$36.

Fourth prize A Waterproof Wall Tent, 12 x 16, made by Abercrombie & Fitch, New York, and listed at \$32.

Fifth prize: An Al-Vista-Panoramic Camera, made by the Multiscope and Film Co., Burlington, Wis., and listed at \$30.

Sixth prize: A No. 3 Focusing Weno Hawk-eye Camera, made by the Blair Camera Co., Rochester, N. Y., and listed at \$27.50.

Seventh prize: A high grade Fishing Reel, made by W. H. Talbot, Nevada, Mo., and listed at \$20.

Eighth prize: A Tourist Hawkeye Camera, 4 x 5, and made by the Blair Camera Co., Rochester, N. Y., and listed at \$15.

Ninth prize: A Bristol Steel Fishing Rod, made by the Horton Mfg. Co., Bristol, Conn., and listed at \$8.

Tenth prize: A pair of High Grade Skates, made by Barney & Berry, Springfield, Mass., and listed at \$6.

The 10 next best pictures will each be awarded one dozen 8 x 10 Carbutt Plates, made by the Carbutt Dry Plate Co., Wayne Junction, Philadelphia, Pa.

The 10 next best pictures will each be awarded one dozen 5 x 7 Carbutt Plates.

The 10 next best pictures will each be awarded one dozen 4 x 5 Carbutt Plates.

A special prize: A Goerz Binocular Field Glass, listed at \$74.25, will be given for the best picture of a live wild animal.

Subjects are limited to wild animals, birds, fishes, camp scenes, and to figures or groups of persons, or animals, representing in a truthful manner shooting, fishing, amateur photography, bicycling, sailing or other form of outdoor or indoor sport or recreation. Awards to be made by 3 judges, none of whom shall be competitors.

Conditions: Contestants must submit 2 mounted prints, either silver, bromide, platinum or carbon, of each subject, which, as well as the negative, shall become the property of RECREATION. Negatives not to be sent unless called for.

In submitting pictures, please write simply your full name and address on the back

of each, and number such prints as you may send, 1, 2, 3, etc. Then in a letter addressed Photographic Editor, RECREATION, say, for instance:

No. 1 is entitled ———.

Made with a ——— camera.

——— lens.

On a ——— plate.

Printed on ——— paper.

Length of exposure, ———.

Then add any further information you may deem of interest to the judges, or to other amateur photographers. Same as to Nos. 2, 3, etc.

This is necessary in order to save postage. In all cases where more than the name and address of the sender and serial number of picture are written on the back of prints I am required to pay letter postage here. I have paid as high as \$2.50 on a single package of a dozen pictures, in addition to that prepaid by the sender, on account of too much writing on the prints.

Any number of subjects may be submitted.

Pictures that may have been published elsewhere, or that may have been entered in any other competition, not available. No entry fee charged.

*Don't let people who pose for you look at the camera. Occupy them in some other way.* Many otherwise fine pictures have failed to win in the former competitions because the makers did not heed this warning.

### VELOX PRINTING.

Now that the printing papers of the velox type are so popular, a few suggestions as to their successful manipulation may be of value to amateurs who are vainly trying to produce good prints by their use. It was more than one year before I could be reasonably sure of obtaining 10 good prints from a package of velox. No doubt the personal equation had much to do with this lack of success, but I am convinced that had some one told me a few things which I had to learn by costly experience, my progress would have been much more rapid.

To be successful with velox, one must be especially careful as to the quality of sulphite of soda used in the developer. The most expensive article is not necessarily the best, for this purpose at least. I have had good results with sulphite costing 8 cents a pound, and on the other hand could do nothing with another make for which I paid 35 cents a pound, though both seemed equally pure and free from sulphate. When you find a brand that works satisfactorily stick to it. The other chemicals are less important; nevertheless, it is not good economy to use cheap ones.

Stick to the acid fixing bath. I have good prints that were fixed in a plain hypo bath, but I have also thrown away many because they were yellow and mottled with brown spots. Papers of this class develop quickly, and it is necessary to use a fixing bath that will get down to business at once and stop development. Otherwise the resultant print will be anything but satisfactory.

When the prints are placed in the fixing bath they should be moved about in it a few moments to allow the bath to get a chance at every part of the print. When a print is carelessly thrown into the bath, it is almost certain that more or less air will be caught between the print and the surface of the liquid, forming bubbles and thus keeping the hypo from acting on the print, so that a spotted print results. The manufacturer's directions mention this fact, but do not sufficiently call attention to its importance. Another evil to be guarded against is the overworking of the fixing bath. Chemists tell how much hyposulphite of soda is required to dissolve a certain quantity of chloride of silver, or in other words, that so many grains of hypo will fix a print of a certain size. Hence it is easily seen that it is entirely possible to use a fixing bath until there is no fixing left in it. Hypo is cheap and it is poor economy to overwork a fixing bath. I have in mind one instance where I failed again and again to produce a good print. Every one turned yellow when placed in the hypo, and after a few minutes' immersion looked as if stained with bichromate of potash. A change of developer was of no avail and it was not until I tried a fresh hypo solution that I located the trouble.

Keep the bath in an acid condition. Do not imagine you can add a dram of acetic acid to a quart of fixing bath, fix a dozen prints and still find the bath as acid as at first. Sal soda, or sodium carbonate, is a powerful alkali; alkalis and acids neutralize, or kill, each other. Every print placed in the fixing bath carries with it a small quantity of developer, containing more or less alkali, which of course goes toward neutralizing the acid in the bath. I test my fixing bath frequently with blue litmus paper and occasionally add a few drops of acid.

Beginners in the art photographic may not be familiar with the use of litmus paper. For them I may say that paper of 2 colors, red and blue, may be obtained. The blue paper, dipped in an acid solution, turns red, while the red paper, when placed in an alkaline solution, turns blue. I keep both kinds on hand and find them both useful.

The light used in printing is important. I have tried several sorts of illuminants

and have settled on a mantled gas light as being the most satisfactory. I have among my collection of horrible examples a 5 x 7 velox print made by a friend when he was a novice in the art. The view is well taken, as far as one is able to judge from the print, but as my friend held the printing frame about 6 inches from the gas jet when exposing the print, only about 4 inches of the center of the print is sufficiently printed to show what it is all about. The ends of the print fade into nothingness in a weird and mysterious manner, much after the style of some of the new school productions we are nowadays called on to admire. If my friend had given a few seconds more exposure to his print, and had placed the printing frame 12 or 15 inches from the gas jet, he would have had a much more even illumination on the negative, and would have obtained an evenly printed picture. I am fortunate in having an abundance of room in which to work.

I work on a long table, on the right hand end of which stands my 10 x 12 hypo tray. Next to it is a tray of water for rinsing the prints between developing and printing. Next comes the developing tray, which is several sizes larger than the actual size of the paper in use. Just to the left of this tray is the developing light, in my case a small oil lamp. I have an 8 x 10 sheet of orange glass which I lean against the chimney of the lamp on the side next the trays, and thus get plenty of safe light. I prefer this to working by a dim white light, as recommended by the manufacturers of the paper.

My printing is done at a separate table, on the opposite side of the room, where I can attach a rubber tube to a gas jet and bring a supply of gas down to the table. I have a burner arranged on a base so that it is about the same height as the center of my printing frame. By placing this burner in the center of the table I can stand several printing frames around it, though as a matter of fact I rarely use more than 2 at once. I like to keep the frames at least 15 inches from the light, as at that distance the illumination is practically uniform, for small negatives at least. A large square of white cardboard placed behind the light helps the illumination, appreciably shortening the time of exposure.

Each of my negatives is kept in a separate envelope, and it is an easy matter, after the correct exposure has been found for a given negative, to jot down on the envelope something like this, "Special portrait velox, 30 seconds, 20 inches, M. Q. developer." This serves as a guide for all subsequent printing.

C. M. Whitney, Bayonne, N. J.



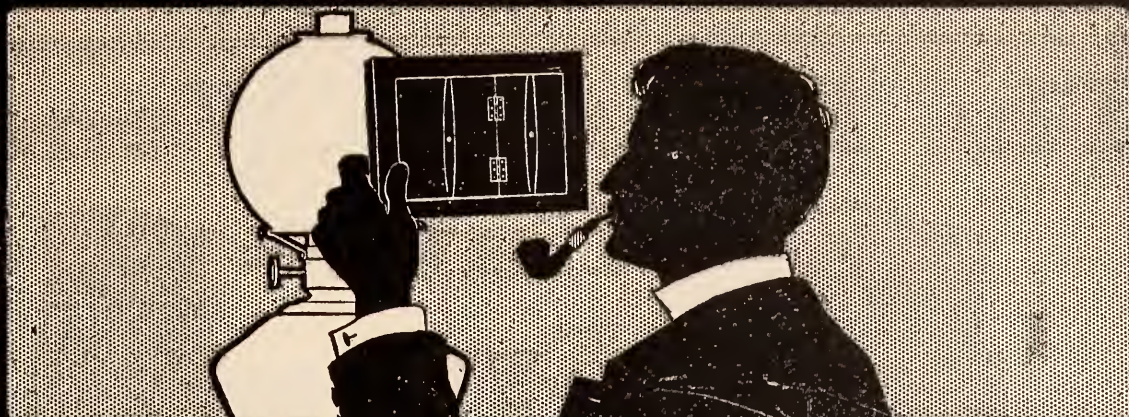

# VELOX

## Liquid Developer

Made especially for Velox by the Velox people—it makes Velox better than ever—and that is saying a great deal.

Four-ounce bottle: Concentrated Solution, 25 cents.

ALL DEALERS.



NEPERA DIVISION,

EASTMAN KODAK CO.

ROCHESTER, N. Y.

OBJECTS WELL CENTERED AND CORRECTLY FOCUSED

# The Focusing Weno Hawk- Eye



has the advantage  
over all cameras

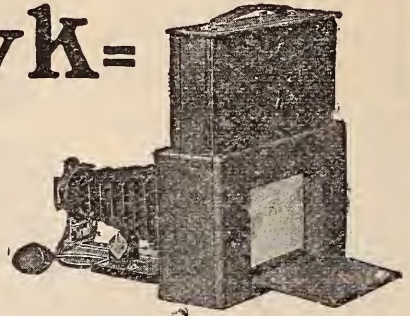

of a ground glass the size of picture, which works automatically and allows focusing when using film. The result is obvious—perfection of work—satisfaction to the user.

**No. 3 Focusing Weno Hawk-Eye, with B. & L. Automatic Shutter, and Extra Rapid Rectilinear Lens. Pictures  $3\frac{1}{4} \times 4\frac{1}{4}$ , " " " = \$27.50**

**No. 4 Focusing Weno Hawk-Eye, same equipment. Pictures  $4 \times 5$ , 30.00**

Hawk-Eye Film can be developed in the Kodak Developing Machine.

*Write for Hawk-Eye Booklet.*

**BLAIR CAMERA CO., Rochester, N. Y.**

## DO NOT FORGET Recreation's Photo Contest

**T**HIS is the time of year to secure prints of **Live Wild Birds and Game, of Camping Scenes or Other Outdoor Sports.** One of these prints may win for you a valuable

**CAMERA,  
LENS, TENT,  
FISHING ROD,  
FIELD GLASS**

or other prize.

See announcement of contest in **RECREATION**, department of Amateur Photography.

### INDESTRUCTIBLE LABELS.

Many methods of making indelible labels have been suggested. Writing on the glass with a mixture of fluoric acid and pigment is satisfactory, but the following will be more generally convenient: Waste celluloid roll films should be cleaned from the photographic film and cut into slips of the sizes required for the labels. The writing may be done on ordinary white paper, but slips of gelatino-chloride paper from which the silver salts have been fixed out are much better. Cement the thin celluloid film on the label, and securely fasten that to the glass. For this purpose nothing is better or more convenient than the well-known Diamond cement sold for mending glass and china. Once set, it is impervious to heat and damp, and though expensive as commonly sold, is not difficult to make when a quantity is required. The formula is to dissolve one ounce of soft gelatine in 3 ounces of water, and to add  $1\frac{1}{2}$  ounces of spirits of wine and 40 grains of gum ammoniacum triturated in  $\frac{1}{2}$  an ounce of water. Finally, add 36 grains of mastic dissolved in  $\frac{3}{4}$  ounce of strong alcohol, and store the cement for use. When required, it must be dissolved by placing the bottle in hot water. It should be used both to attach the celluloid to the label and that to the bottle. Practically nothing will destroy such a label, and a wet cloth will at all times keep it clean.—Photography.

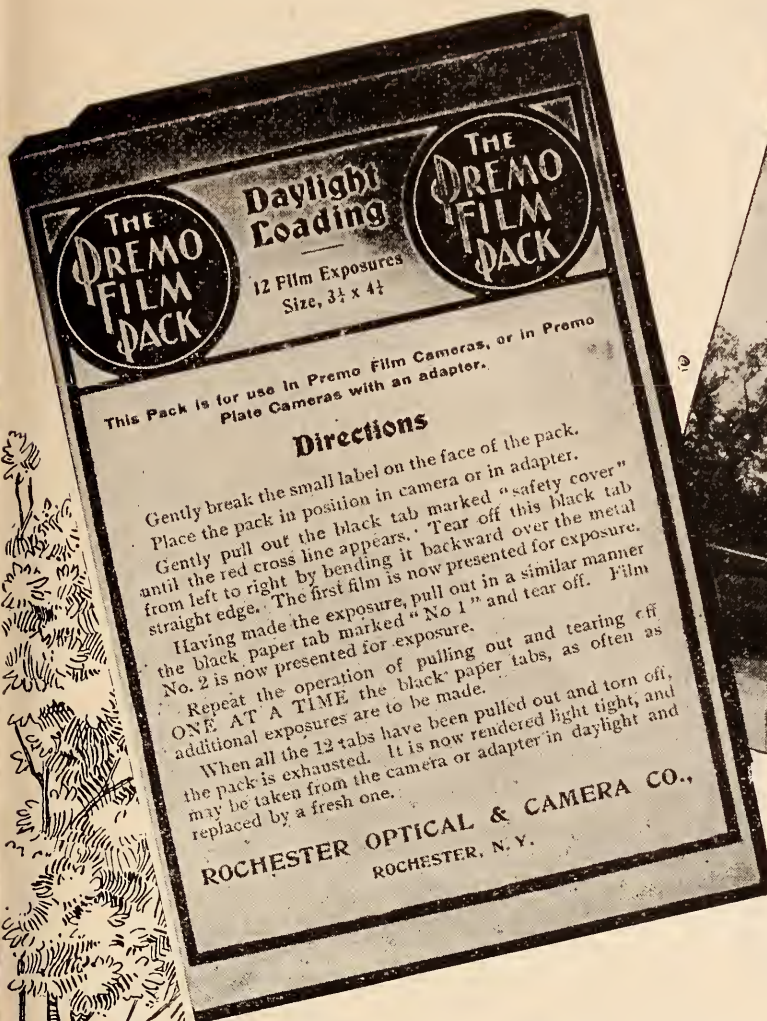

## The Pack and the Picture— A Very Simple Matter.

Amateur photographers have received the new PREMO Film Pack with almost extravagant praises. It meets the conditions of the outdoor picture maker as nothing else has ever done. Whether you use a PREMO Plate Camera or a PREMO Film Camera, it opens the easy way to photography;—a working outfit that is unequalled for simplicity and convenience.

# The PREMO Film Pack

## DAYLIGHT LOADING

As flat as a handkerchief in your pocket when not in use, as easy to load in daylight as shutting a book; it is unequalled for effectiveness. Carrying twelve non-curling, orthochromatic films; successive exposures are made by pulling out the numbered black paper tabs. The last tab seals the package light tight. Adapted to  $3\frac{1}{4} \times 4\frac{1}{4}$  and  $4 \times 5$  Cameras, the PREMO Film Pack meets successfully every photographic condition. See it at your dealer's or write for particulars contained in the *Premo Year Book*, free.

**ROCHESTER OPTICAL CO., Dept. 209, Rochester, N. Y.**

# ROTOX

**PRINTS IN ANY LIGHT**

From each dozen sheets of ROTOX developing photo paper you can surely obtain twelve perfect prints. It prints from negatives too thin for other papers; is easier to manipulate and has a range of latitude that is unequaled.

**PLATINUM BLACKS**  
 Prices, per dozen, thick or thin, rough or smooth: 4x5, 15 cents; 5x7, 30 cents; 6½x8½, 55 cents; 8x10, 70 cents.



**"ROTOGRAPH,"** *the best bromide paper, same prices.*

Sample copy of the *Photo Critic*, containing, every month, articles on "The A to Z of Photography." Of interest to amateur and professional, sent FREE.

*Subscription, \$1.00 per year. Write*  
**ROTOGRAPH, Dept. V, 101 5th Ave., New York City**

Do you want a Good, Reliable,  
 Substantial, Well Made

## Single Barrel Shot Gun

If so, send me

**10 YEARLY SUBSCRIPTIONS**

and I will send you such a  
 Gun as a premium

It is made by the *DAVENPORT ARMS CO.*, and this means it is made of good material and that only good workmanship is put on it.

This is one of the many remarkable opportunities *RECREATION* is offering to men and boys to fit themselves out completely for shooting and fishing.

Sample Copies for Use in Canvassing  
 Furnished on Application.

Address

## RECREATION

23 W. 24th St., New York City.

**The Best Yet:**—To any person sending me \$2, express or money order, for one year's subscription to *RECREATION*, I will give free, one fine 3 joint bamboo rod, 7 to 9 feet long, one nickel plated 60 yard multiplying reel, and 50 yards of water-proof silk line. This outfit, including *RECREATION*, would cost \$6. Or I will give the above outfit for 7 yearly subscriptions to *RECREATION*. Or I will give the 50 yards of silk line, listed at \$1, for one subscription and 25 cents extra. This line is a very fine outfit and would retail in any store at \$1.

C. W. Jacobs, 339 N. 2nd St., Coshocton, O.

**Something Special — Playing Cards Free:**—To each person sending me \$1 for one year's subscription to *RECREATION*, or sending it direct to be placed to my credit, I will forward, all charges prepaid, a pack of elegant gold edge playing cards. These are no cheap second quality cards but first quality, of extra selected stock, highlyenameled and polished, fancy set pattern backs, each pack wrapped in handsome glazed wrapper and packed in strong telescope case.

L. J. Tooley,

141 Burr Oak St., Kalamazoo, Mich.

The J. C. hand trap which I received as a premium through you from the Mitchell Mfg. Co., London, Ohio, is as good as recommended. At our first attempt with blue rocks we succeeded in breaking 60 out of 100. I advise all marksmen to secure a J. C. hand trap and practice on blue rocks, so when the shooting season opens again they can pick out a single bird instead of shooting into the thickest of the flock.

Jacob H. Henn, Jr., Freemansburg, Pa.

The Bristol steel rod that you gave me as a premium received. It is entirely satisfactory. Will send more names soon.

*RECREATION* is having a great influence. It puts gentlemen on their honor and excites a dog. Game is scarce here.

C. P. White, Worcester, Mass.

I feel like grabbing my old rifle and taking to the woods whenever I get a copy of *RECREATION*, it is so real. I have hunted big game in Colorado since '81, and most of the stories you print sound very natural.

Frank Swartz, Aspen, Colo.

**LANTERN SLIDES COLORED  
 SKILLFULLY AND ARTISTICALLY**  
 FOR  
**Lecturers, Teachers and others**

I refer by permission to the Editor of *RECREATION*

**MRS. C. B. SMITH**

606 W. 115th Street, New York City



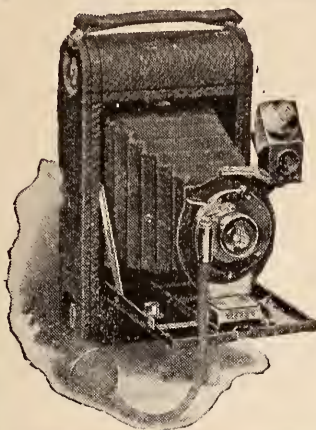

## Increased possibilities. All the old simplicity.

### The New Model No. 3 Folding **POCKET KODAKS**

have automatic shutters with pneumatic release, and high speed lenses.

**Price Unchanged: \$17.50.**

*Catalogue of Kodaks and  
Kodak Goods at dealer's  
or by mail.*

EASTMAN KODAK CO., Rochester, N. Y.

#### AN EXPERIENCE WITH THE 30-30.

Last September I bought a 30-30 Marlin repeater and lined up the sights all right. Then I went deer hunting. The first deer I shot at was standing broadside to me on the shore of a lake, not 20 rods away. I aimed as near the heart as possible and fired. The deer jumped and landed on his back. He got to his feet again, ran about 5 rods along the shore toward me, fell, regained his feet and turned up the bank toward the woods, which stood about 20 feet from the water. After another fall he reached cover and ran perhaps 4 rods when I heard him go down with a crash. The guide with me said, "You have him all right"; but when we went in after him he was gone, and we could not find him.

A day or 2 later I fired with the same gun at a big buck within 20 rods. The bullet struck him deep in the right hind quarter, ranged forward and lodged just under the skin in front of the left shoulder. He jumped out of the water into the bushes on the bank and stopped. As he did so I fired again, hitting him half way between the heart and the backbone. He came back down the bank into the water. I was then within 50 feet of him, and fired a third shot, hitting him in the right shoulder, the bullet coming out the left side of his breast. Getting ahead of him I shot him just back of the right shoulder. This bullet came out midway between his hams. The guide shoved the boat in until I was not more than 10 feet from the buck. I fired and the bullet went through the animal's breast.

As I fired the fifth time he jumped for the boat, missing it by a few inches. Again he lunged. That time his front feet just cleared it, but his head would have struck the boat if I had not grabbed him by the horns and pushed away. Then the poor brute got into deep water and it took him 2 or 3 minutes to drown. He weighed before being dressed a little over 350 pounds. There was not a hole in his skin that would measure  $\frac{3}{4}$  inch in diameter.

I sold that 30-30 as soon as I could. Now I have a '99 model .303 Savage, with a Side telescope, and would not trade it for all the 30-30's I ever saw.

E. G. Dewey, Hanover, N. H.

#### OIL PORTRAITS ON APPROVAL.

If you will send me a photo of yourself or a friend and state color of hair, eyes and complexion I will paint and send you on approval a miniature oil or pastel portrait.

Canvas 6x8 or 8x10 inches, \$10.00

Canvas 10x12 or 12x14 inches, \$15.00

Z. EMMONS, 58 West 104th St., New York.

Reference: Mr. G. O. Shields.

## Something New!

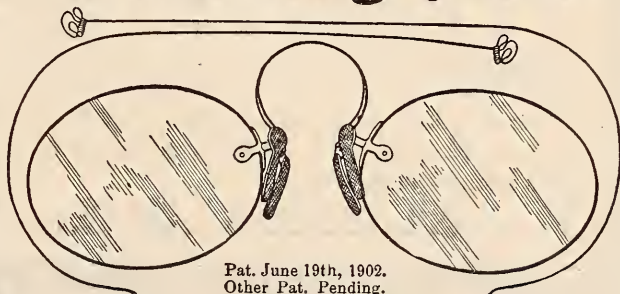

Pat. June 19th, 1902.  
Other Pat. Pending.

### PRESTO! CHANGE!

#### Attachable Eyeglass Temples

Every wearer of eyeglasses wishes occasionally that they were spectacles. Spectacles stay on, however violent one's exercise, however warm or stormy the weather. This little device can be readily attached or detached without injury to the lenses, thus in a second giving you the choice of either spectacle or eyeglass. Just the thing for outdoor sports. The Temple Attachment will fit any of your eyeglasses and can be carried in the same case with them.

Send thickness of lens when ordering by mail.

Price in Nickel, 50 cents a pair

Price in Gilt, 75 cents a pair.

Send for Circular.

*Our illustrated catalogue can be had for the asking*

We carry everything in the Optical and Photographic line Eyeglasses, Spectacles, Cameras, Opera, Field or Marine Glasses, Thermometers, Barometers, Telescopes, Hygrometers, Sun-dials, etc.

**GALL & LEMBKE, Department C.**

1 W. 42d Street

21 Union Sq., New York

Established 1842.

# ALVISTA CAMERA



**T**AKES everything within half a circle, making a picture five inches high by twelve inches long; or you can stop the revolving lens at different points and make exposures either four inches long, or six inches, or ten, depending upon how much you want to get in the picture. No wasted film. The revolving lens moves at different speeds, so you can gauge your exposure accurately. The exposure of the film is on the same principle as the focal plane shutter for pictures of moving objects. Our catalogue tells of its many uses—free.

**MULTISCOPE & FILM CO., 136 Jefferson St., Burlington, Wis.**

# AL-VISTA PANORAMIC CAMERA



## THE HEIGHT OF ART in camera work

Perfection in photography, has been secured by the use of the Al-Vista Camera. It produces the entire panoramic view — from the limit of vision on the left to the extreme point on the right. The Al-Vista Camera is compact: easy to use, sure in action. It is sold on its merits: we demonstrate this by selling you one

## on easy payments

Ask us for a catalog: select the camera you wish, fill up the blank we shall send you, and references being satisfactory we will at once send you a camera—pay weekly or monthly in sums to suit your purse. The camera is no longer a luxury: the demands of modern progress make a good camera a necessity; we make it easy for you to get the best, an

## Al-Vista.

*The*

## Multiscope & Film Co.

136 Jefferson St.

Burlington, Wis., U. S. A.

The Superiority of  
**“Century”**  
 Cameras

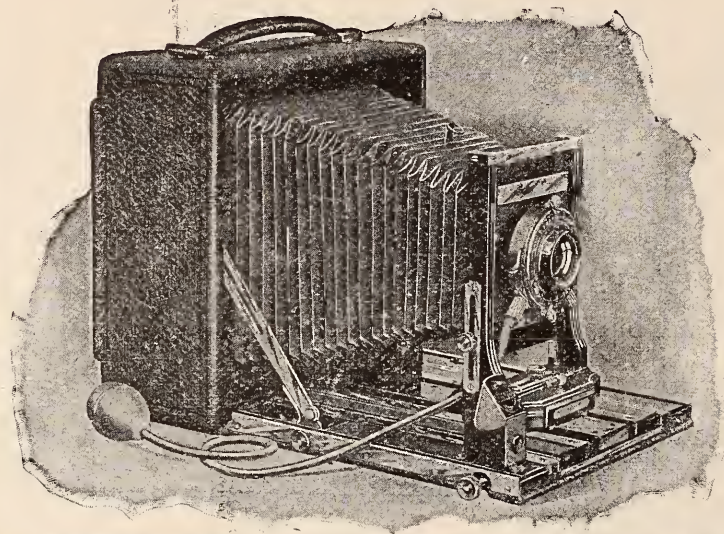

nas won for them the highest praise from Connoisseurs everywhere.

“Century Quality” is the result of twenty years’ practical experience. **Century Cameras** are the finest in the world and the most for the money. Our new catalogue tells why. Can be obtained from all dealers free, or by mail direct.

**Century Camera Co.**  
 Rochester, N. Y.

April and October provide us with the most gorgeous sky scenery of the year, and as generally useful a class of cloud study as can be wanted. The mistake the beginner is most prone to make when attempting to secure cloud negatives is that of aiming the camera too high, and so securing zenith forms, or something approaching them, rather than those to be found within the limits which usually bound a photograph. Keep the camera perfectly horizontal at all times, and do not attempt to get more in than can be obtained by the use of the rising front as usually fitted. Always include the sky line, if it is only a line at the bottom of the negative. Expose long enough to get negatives which show no bare glass or anything like either under exposure or over development. A cloud negative so dense that it can not be arranged in its proper position on the print, is better not taken at all. For cloud work a long focus lens is only occasionally useful. Cloud subjects that are likely to attract the photographer’s attention nearly always include a fairly wide angle.—Francis Fielding in the *Photo-American*:

Those whose eyes ache after working long in the ruby light should try 10 grains of boric acid in an ounce of water. Mix with an equal volume of warm water and bathe the eyes with a bit of sponge dipped in the warm solution.—Exchange.

Do not mix your own flashlight powders unless you know something of chemistry; it is dangerous. Use backed plates to avoid halation around the high lights. A dark curtain is a useful background for portraiture. Place some opaque object between the lens and the flame to prevent the burning of the powder being shown in the picture. Leave bromide out of your developer.—Exchange.

I enclose herewith \$1 for one year’s subscription to RECREATION. Having seen a few copies of your magazine, we feel that we could not be the “20th Century Club” without RECREATION on our list of periodicals.

R. L. Wiley,  
 Secretary Century Club, Seneca, Ill.

I received the Hemm & Woodward wick plug you sent me as premium and it is perfectly satisfactory in every way. I do not see how you can afford to give such valuable premiums for so few subscriptions.

D. S. Featherstone, Everett, Wash.

RECREATION is a first class sportsmen’s magazine. The articles under guns and ammunition are exceedingly interesting and contain much valuable information for a new hand with a gun.

C. F. Morris, Batavia, Ill.

# ? RELIANCE ? SHAMROCK ?

Have you picked the Winner? Then you'll want to see her win. We can help you,—with the peerless

## TURNER-REICH BINOCULAR

When you pick your Winner among BINOCULARS, place your RELIANCE on the TURNER-REICH; it's no SHAM....



Write for Price List

**GUNDLACH-MANHATTAN OPTICAL CO.**  
730 So. Clinton Ave., Rochester, N. Y.

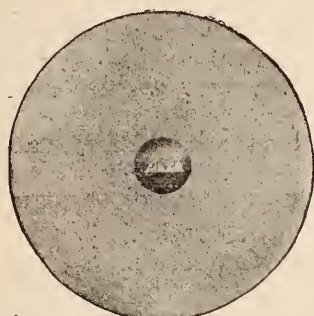
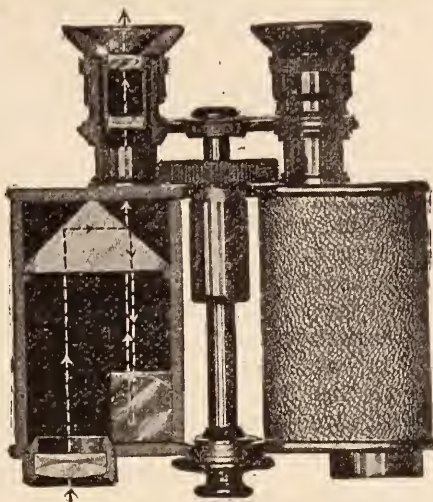

Size of yachts as seen with the unaided eye.

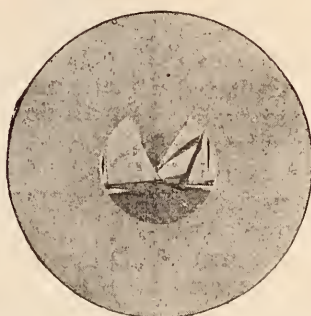

Field of the bulky old style 8-power Binocular



As seen with the 8-power Turner-Reich Binocular



Made with The  
**KORONA  
CAMERA**

1884

NINETEEN



1903

YEARS'

**Optical and Mechanical Experience**

is the HERITAGE of the

# 1903 KORONAS

You cannot afford to buy a camera before you've seen and examined the new **KORONAS**.

You need an Anastigmat? We have two to offer:

The **TURNER-REICH** and the **VERASTIGMAT**

How about a Wide-Angle Lens in cells to fit your shutter? It's an **EMIL** you want.

**Gundlach-Manhattan Optical Co.**  
ROCHESTER, N. Y.

## SOME SHOTS AND ONE GRIZZLY.

There is no grander country out of doors than Northern Idaho, especially that portion of it drained by the various branches of the Kooskooskie. It is fretted with towering mountain peaks of the Bitter Root range and traversed by almost fathomless canyons, through which run brawling torrents alive with trout. It was once my good fortune to penetrate this fastness. Our quest was bear and deer, of which there was no lack from the time we abandoned the wagons at Hartmann's Mussellshell ranch and took the trail of the Lo Lo. Our guide, a half breed, knew every deer trail in the Bitter Roots, from Lewiston, Idaho, to Lewiston, Mont., and had promised us a shot at a grizzly. The trail wound over the spurs of the main range, drawing nearer to the snow-capped peaks above us. The first night we camped in 4 inches of snow, though it was only October. The next night found us at the old trapper's cabin on the Locksau, and somewhat sheltered from the high winds by the canyon walls. There we found scant forage for the horses to eke out the supply of oats we carried. Bear tracks were everywhere in evidence, but mostly of blacks. The second day we ran on to a footprint the size of a market basket that told to the most inexperienced eye there was at least one grizzly in the hills. The Englishman was for giving immediate chase, and was only restrained when told that the sign was 3 days old.

The first day after making camp the guide had killed a small buck and used the greater part of it to lay a series of baits up the canyon, extending in a line from camp about 5 miles.

The third day a small black bear was killed by the reporter, armed with a 50-70. There was barely enough of that youthful Bruin left to account for after the quill pusher concluded he was safely dead. We visited the baits regularly every morning without success for nearly a week, but fortune smiles on those who wait.

One morning we found a bait gone, and the size of the tracks in the snow told we had a big grizzly on the string. We took up the trail, only to find the second bait gone. The trail led in a direct line for the third and last trap. Toward that we started, all the time keeping a sharp lookout ahead. When some 150 yards away we heard a satisfied grunting. Rounding a corner of the boulders, we saw our bear up on the hillside, looking as big as a box car. The Englishmen was armed with an elephant gun, throwing an express ball as big as a walnut. He at once became possessed of a desire for bear gore and taking counsel only of his ambitions, fired. Immediately that bear was buried in a cloud of snow and gravel. Our Britisher had undershot. When the fog cleared, we saw that mountain of bear meat rolling down the hill in our direction, emitting the most hair-raising roars it was ever my pleasure to hear. The reporter and the other fellow opened up with an arsenal composed of

50-70 and 38-55. Our shots seemed only to cause Mr. Ursus to accelerate his pace in our direction, and in all conscience he was already coming fast enough. He was uncomfortably close, and at least one member of that party was eying a convenient spruce with a view of getting up on one of the topmost branches to look at the scenery, when I heard the spiteful bark of the little 30-30 carbine in the hands of the guide. Twice it barked, and I saw the bear stop and shudder. Again the whiplike snap, and he huddled all up and came tumbling down the hill, dead before he reached us. Skinning revealed the fact that 6 balls had found lodgment in the carcass, but only 3 of them had done sufficient execution to put a stop to his progress; the 3 fired out of the little toy gun. The last had struck the bones of the neck a little above the center, and had torn off the entire half, severing the spinal cord and stopping the bear.

One member of the party became a sudden and lasting convert to the modern small bore gun.

C. S. Moody, Sandpoint, Idaho.

## IF AN OATH WERE NOT A SWEAR.

LOU B. HAYDEN.

Did you ever have rheumatics

Come a-creeping up your back?

Stealing through your joints and knuckles

Like an engine off the track?

Did you ever bend up double

When you tried to leave your chair?

At such times we would be thankful

If an oath were not a swear.

Did you ever burn your fingers

When you thought the dish was cold?

Did you ever test the hens' nests

Just to find the eggs were old?

You've been beaten in a horse trade,

Then pretended not to care,

But you wished with ardent fervor

That an oath was not a swear.

When you tried to fix the stove pipe

And you could not make it fit,

When you would have killed the wildcat

If your shot had only hit;

When you missed the train you wanted

By the tenth part of a hair,

Didn't your conscience almost tell you

That an oath was not a swear?

When you tried to fix your collar,

And kept losing out the stud;

When you donned your suit at Easter

Then slid softly in the mud;

And the tack that pointed upward

Just the time your feet were bare,

Made you feel, just for the moment,

That an oath was not a swear.

When the girl you hoped to marry

Said she'd be a sister kind,

But she loved your rival better,

And she hoped you would not mind;

These, and many like occasions,

All mankind in general share,

And we'd all be oh, so thankful!

If an oath were not a swear.

# Tampering with the Wires

Against the Law and Dangerous.

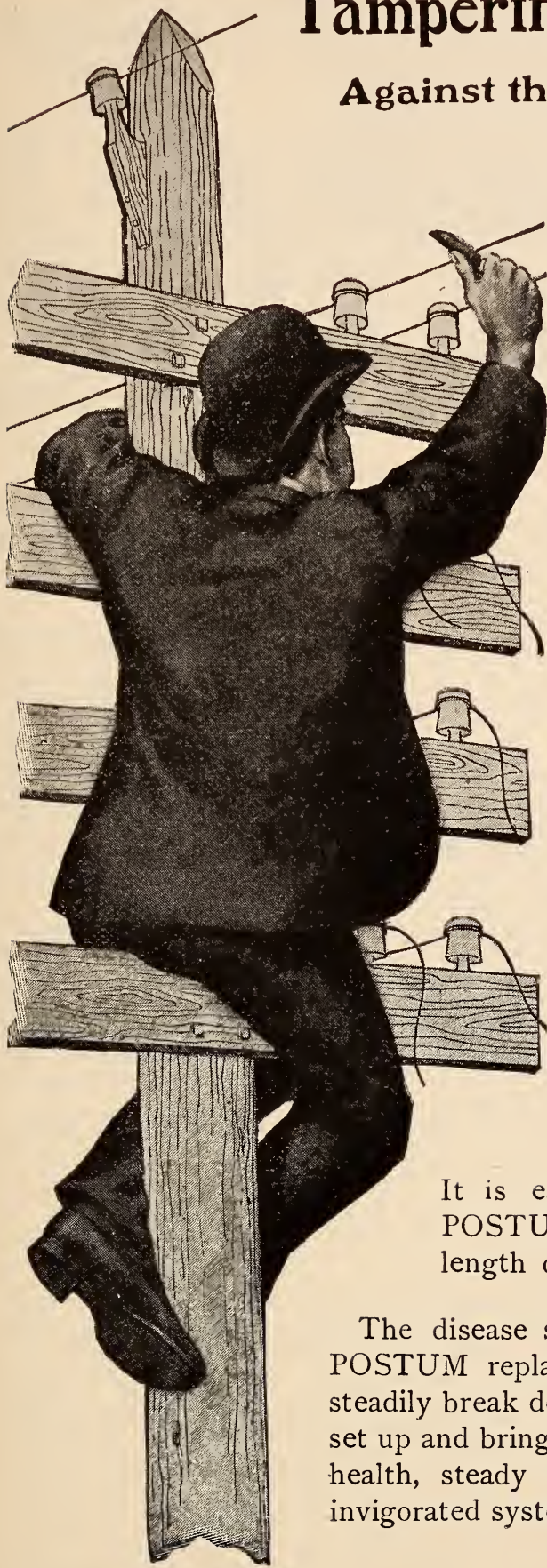

Coffee directly attacks the heart and nerves to such an extent that life insurance companies have recently added the term "Coffee Heart" to the list of dangerous maladies. Coffee is also responsible for most of the indigestion and dyspepsia in the world, and the fact that it is a pronounced diuretic irritant causes many cases of kidney trouble.

Medical science tells us coffee is responsible for more suffering than any other drink in common use. In its concentrated form coffee is a dangerous drug, to be rated with morphine, strychnine etc. The man, woman or child who drinks coffee puts him or herself at odds with Nature's laws and tampers with the network of delicate nerves.

Many sufferers know all these facts yet continue drinking coffee or tea because they feel the need of a hot drink at mealtime. They cannot (or think they cannot) quit.

It is easy to break away by shifting to **POSTUM COFFEE** boiled the proper length of time and served with rich cream.

The disease symptoms begin to change the day **POSTUM** replaces coffee and the **POSTUM** will steadily break down those diseases which coffee has set up and bring back the delicious feeling of returned health, steady nerves, clear head and a generally invigorated system.

If health and steady nerves are worth while, make the change. It's a very simple matter to give **POSTUM** a ten days' trial. Results will tell.

There's a reason.

# EYES CURED AT HOME

The Most Serious Eye Troubles Successfully Treated in Patient's Own Home Without any Possibility of Injury by

THE ONEAL DISSOLVENT METHOD



People afflicted with every form of eye trouble have cured themselves in their own home by applying the Oneal Dissolvent Method under the direction of Dr. Oneal, Chicago's noted oculist, who is the discoverer of this wonderful treatment. It has never failed in the most serious cases of cataracts, scums, granulations, optic nerve troubles, and all other causes of blindness where any sight remained, and it was given a fair trial. Dr. Oneal is very proud that in all the years of his practice he has never injured the eye of a patient. His wonderful book, "Eye Diseases Cured Without Surgery," fully illustrates and describes all eye diseases, and tells how you can be cured at home at small expense and in a short time. It also gives much valuable information about the care of eyes and is sent or given absolutely free to all who ask for it. It contains letters from people in all parts of the world, who have been cured at home of the most serious eye diseases. There is hope for all by this simple, sure and harmless treatment. Mrs. C. H. Sweetland, Hamburg, Iowa; Rev. Alfred Martin, Mapleton, Iowa; Mrs. Herman Burdick, Richland Center, Wis.; Miss Johanna Schmiat, 302 Seventeenth St., Milwaukee, Wis.; A. J. Staley, Hynes, Cal., are just a few who have cured themselves at home, and who will be glad to tell you their experience if you write.

Cross eyes straightened, no knife or pain, a new method, always successful. O. J. Lehman, Naperville, Ill.; John J. Seiler, Libertyville, Ill.; John Lehman, 1200 East 5th Street, Dayton, Ohio; Chas. Wilkens, Mt. Pleasant, Iowa, are a few who were cured.

If you will write Dr. Oneal telling him about your eye trouble he will be glad to give you his advice and opinion free. It will in no way obligate you to take the treatment. Address all communications to Oren Oneal, M. D., Suite 839, 52 Dearborn Street, Chicago.

## A MISPLACED TICKET.

I had gone about 85 miles from home on a hunt, having started down the evening before, and bought a single trip ticket. The next morning I started out to try my luck.

The train came along; the car was well filled, and a young lady came in and took the seat next me. The front door of the car opened just then, and the conductor called out, "All tickets, please!"

I commenced to feel for my ticket. Of course I did not want to grow desperate over finding it, as the young lady sitting next me didn't have any more than her share of room at best. I felt in the upper right pocket of my vest first and pulled out 3 cards, but no ticket. That seemed queer. I was sure I had put it in that pocket. I felt in the upper left pocket of my vest. No, it was not there. I was commenced to feel a little rattled, but thought the only thing was to keep cool, for I was sure I had bought a ticket. The conductor had collected tickets from the first 3 seats on my side of the car. I felt in both inside pockets of my coat, but with no result. Then I tore frantically through all my pockets. Little beads of sweat stood on my forehead and I was sure everybody in the car was looking at me; but I must find that ticket before the conductor got to me. He had reached the seat in front of me, and I then had the contents of my pockets out on my lap, madly fumbling over the mass; but the search seemed fruitless. Perdition! No ticket, only 35 cents—and a comely young lady at my side! The conductor was opposite me then, while I quaked with apprehension. He looked at me an instant and then calmly pulled the ticket out from the band of my hat, where I had carefully placed it! The shock was something fearful. Hereafter I'll hold my ticket in my hand.

Alfred P. Darlington, Denver, Colo.

## A SPRING GAME HOG.

B. T. I.

Smith—"I say, Brown, every spring shooter is a game hog."

Brown—"How is that? I was out yesterday and quit after killing only 6 pairs of mallards."

Smith—"When Mrs. Brown dressed those ducks, she found small eggs in all the female birds, did she not?"

Brown—"Yes, she did, and said it was a shame to kill them now, and it's only the 15th of March. But how about being a game hog?"

Smith—"Well, you not only killed 12 old ducks, but what would have been 6 flocks, say about 100 in all."

Brown—"For heaven's sake, Smith! I never thought of that. I give you my word I will shoot ducks only in the fall hereafter."





**"Acts while  
you take"**

**Headache,  
Colds, Fatigue,  
Neuralgia, "Everyday Ills."**

*The Great Human Missions of*

# ORANGEINE

POWDERS

## Prevention

Its accurate corrective power promptly reaches cause of incipient ailment and prevents little ills from becoming serious. Offsets chill, exposure, fatigue, excess. In big establishments it saves hours of time and suffering for employer and employee.

## Relief

It almost instantly reaches the cause of pain, all kinds of Headache, Neuralgia, and the pain ceases. Under systematic use it dispels even chronic cases of Headache and Periodic Pain.

## Cure

Advanced Colds, Grip, Dyspepsia, Indigestion, Nervousness and General Debility quickly disappear under the systematic use of Orangeine, which corrects functional action, increases assimilation of nourishment. Builds Tissue.

**Trial Package Free** Orangeine is sold by druggists everywhere in 25c, 50c and \$1.00 packages. On receipt of request we will mail 10c trial package FREE with full directions, composition and description of its wide human influences. Address "**ORANGEINE,**" Chicago, Ill.

Marlin Repeating Arms Co.

Dear Sirs: I have read articles in RECREATION from different writers about Marlin rifles jamming, and will tell you my experience with one of your guns. I once owned a 25-20 half magazine, model '94, which, though an accurate arm, was defective in action. I could not tell when it was going to balk. One day while hunting and after walking 12 miles without seeing a living thing I fired at a great blue heron. When I threw out the empty shell the next jammed and I had to walk a mile to a farm house for tools to open the lock and remove the shell from the action.

I tell you this to show how unjustly Mr. Shields was treated for publishing a similar statement written by one of his subscribers. I think it was unwise to withdraw your ad from RECREATION because it printed someone's honest opinion about your guns.

L. O. Ashbury, Auburn, N. Y.

### A COWBOY BREAKFAST.

"What's this cowboy breakfast people are talking about? The only description I ever heard was given by a ranchman, who said it consisted of chops, a glass of whiskey and a dog."

"Why a dog?"

"To eat the chops."—Boston Herald.

## WANT A REEL?

You can get one for nothing.  
Or at least for a few hours' work.

Send me

15 Yearly Subscriptions

to

# RECREATION

and I will send you

## A TALBOT REEL

Listed at \$20.00

Made by W. H. Talbot, Nevada, Mo.

This is one of the finest pieces of fishing tackle ever made. It is built like a gold watch. Equal to ny Kentucky reel you ever saw.

**In Tournaments, Always a Victor  
Among the Angler's Treasures, Always the Chief**

I have but a few of these reels in stock and this offer will be withdrawn as soon as the present supply is exhausted.

Sample copies of RECREATION for use in canvassing furnished on application.

In happy homes, wherever found,  
One hears the Washburn's merry sound

## THEY PLAY WASHBURN



## MANDOLINS GUITARS AND BANJOS.

Unequaled for Tone, Durability  
and Workmanship.

We will gladly send free a beautiful Art Souvenir Catalogue and "Facts About The Mandolin" and "How to Play The Mandolin" if you will send us your address on a postal card.

**LYON & HEALY,** 28 Adams St.,  
Chicago.

The World's Largest Music House. Sells "Everything Known in Music."

### ATTENTION BASS FISHERMEN !!

**What It Is.** A Bass lure combining all the good points of the old fashioned spinner baits with the construction of the modern wooden minnow.

**What It Will Do.** This lure is constructed in a new manner with a new feature and will catch more bass than any other artificial lure.

**How To Get It.** Send one dollar to Recreation for a year's subscription to be credited to my account and I will mail you one postpaid. **W. B. HAYNES, 274 Park Street, Akron, Ohio.**

### IN YOUR OUT DOOR LIFE

YOU WILL NEED A

## Duplex Fork



for handling hot potatoes, ears of corn, boiled eggs, and other hot food, and you will find it indispensable for use with pickles, fish and meats that an ordinary fork will break. The forks are always open and ready for use, and with a slight pressure on the handle anything can be easily taken hold of without fear of breaking.

Postpaid, 25 Cents

E. A. LYFORD, 3090 Gilbert Ave., Cincinnati, O.  
Mention RECREATION.

### CURLING.

Every photographer is annoyed at the sight of his mounted prints bending or curling inward after drying. The reason for the bending of the mounts is, of course, that the print expands on having the wet mountant applied to its back. On drying, it contracts, and must haul the mount inward in doing so.

In mounting prints direct from the washing machine, the buckling is still marked when all is dry, because of the greater moisture in both the paper and the film. Take a cockled, mounted print after it is thoroughly dry, and on the back of the mount paste a piece of thin white paper, such as printer's demy, or the wrapping paper used by chemists after it has been soaked in water, and dried on a glass slab or between sheets of blotting paper. Tissue paper answers perfectly in the case of mounts of average thickness. The paper need not be so large as the mount, but it should extend to within a quarter or half an inch of the edges.

In cases where both the photographic paper and the mounts are extra thick and tough, it may require a strong, heavy paper, such as brown wrapping or cartridge, to counterhaul the mounts. A few experiments will soon show what is exactly needed to bring the different mounts straight.

It is well to watch how long different papers require to absorb moisture, how far they stretch when wet, and how far when only damp, so that some method or system may be adopted to apply the papers at such a stage that, when dry, they will haul the mount straight and truly flat. A little curl outward will not matter in most cases; better to be curled out than in, but, with 2 or 3 trials, it is a simple matter to ascertain exactly what to do to have the mounted photographs flat and true when dry. Besides, the paper on the back always adds to the general solidity.—Amateur Photographer.

Nature's sun-blinds are the clouds. The photographer in his studio admits light here and excludes it there, until he secures just that particular lighting which his subject demands. Watch a landscape on a day of sun and cloud, and notice the marvelous variations in effect as certain parts are illuminated by sunlight, while others are darkened by the flying shadows of the clouds. Such incidental lighting is of infinite assistance to the observant picture maker, and affords opportunities that are entirely absent with a cloudless sky. Remember, however, that the pictures so produced must have the original cause of these masses of light and shade correctly indicated by the sky; there must be no cloud shadows with a clear sky.—Exchange.

I think RECREATION easily leads all other sportsmen's papers. It is a gem. My family enjoy it fully as much as I do, and that is putting it strongly.

Andrew E. Veon, Brainerd, Minn.

# Free! Hunters, Sportsmen, Free! Campers Out, Etc. Etc.

Fairly bristles with facts and information from start to finish. A complete up-to-date volume, entirely covering the subject of "Camping Out and Outfits."

A Book of 136 Pages

Pronounced by the very best authorities the most practical work ever published on the subject.—A Handsome volume.

Glitters with Pictures  
from Cover to Cover

136 PAGES. In all  
over 200 Illustrations

Bound in Linen, 5 Col-  
or Covers

Size, 6½ x 4½ inches

**FREE!**

Brimfull of brainy facts exhaustively covering every subject from A to Z, interesting and of instructive value and service to every sportsman and camper out, old or young. We have thousands of letters from all over the World (some from noted sportsmen),

who congratulated us upon these books. Contains a thousand facts of value never before put in print, and there is scarcely a campaigner *anywhere*, no matter how old or experienced he may be, who cannot learn something from these books. They are better than some books sold at \$1.00 a copy, or your money refunded.

1st edition of 50,000 copies nearly exhausted.

**They are Free to You** on receipt of 10c., coin or stamps to cover cost of mailing them to you. Address

**"Buzzacott" Dept. A**  
**COMPLETE CAMP OUTFITTER**

Chicago, Ill., U. S. A.

If you be wise write at  
once for this book;  
It'll surprise you

Mention RECREATION.

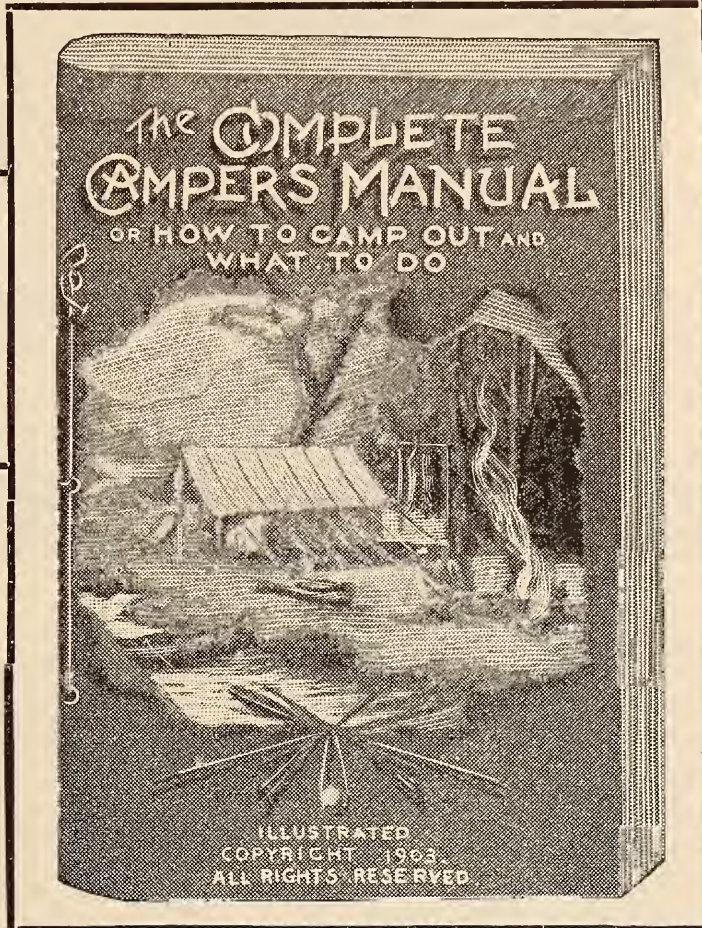



**H. J. TILLOTSON, M. D.**  
The Master Specialist of Chicago, who Cures Varicocele,  
Hydrocele, and treats patients personally.  
Established 1880.  
(COPYRIGHTED)

manent. My consultation will cost you nothing, and my charges for a perfect cure will be reasonable and not more than you will be willing to pay for the benefits conferred.

**Certainty of Cure** is what you want. I give a legal guaranty to cure or refund your money. What I have done for others I can do for you. I can cure you at home

**Correspondence Confidential.** One personal visit at my office is preferred, but if it is impossible for you to call, write me your condition fully, and you will receive in plain envelope a scientific and honest opinion of your case, Free of charge. **My home treatment is successful.** My books and lectures mailed free upon application.

**H. J. TILLOTSON, M. D., 140 Tillotson Bldg, 84 Dearborn St., CHICAGO**

# Varicocele Hydrocele

**Cured to Stay Cured in 5 Days.  
No Cutting or Pain. Guaranteed  
Cure or Money Refunded.**

**VARICOCELE.** Under my treatment this insidious disease rapidly disappears. Pain ceases almost instantly. The stagnant blood is driven from the dilated veins and all soreness and swelling subsides. Every indication of Varicocele vanishes and in its stead comes the pleasure of perfect health. Many ailments are reflex, originating from other diseases. For instance, innumerable blood and nervous diseases result from poisonous taints in the system. Varicocele and Hydrocele, if neglected will undermine physical strength, depress the mental faculties, derange the nervous system, and ultimately produce complicated results. In treating diseases of men I always cure the effect as well as the cause. I desire that every person afflicted with these or allied diseases write me so I can explain my method of cure, which is safe and permanent.

## EXTRAORDINARY OFFER.

To any person sending me \$1 for a year's subscription to RECREATION, I will give free one of the following books: 6th and 7th Books of Moses. This is a great book. Every home should have one. Volumes I.-II., bound together in one volume; regular price is \$1. "The Almighty Dollar" is a new book just published, and is worth its weight in gold to any one. Can not be obtained for less than \$1 anywhere.

"Hunter's Guide and Trapper's Companion." This is a book every hunter and trapper should have. Descriptions of these books will be sent for a stamp. This is the greatest offer ever made, and you should not let this pass. Old subscribers may avail of this offer by sending 10 cents extra. Address Henry Nelson, Eckwoll, Minn.

Murrinsville, Butler Co., Pa.  
The Peters Cartridge Co.,  
Cincinnati, Ohio:

Dear Sirs:—I have noticed the letter of your secretary, Mr. J. H. McKibben, in RECREATION, wherein you jump on G. O. Shields, and order him to discontinue your ad because one of your own townsmen, Mr. C. A. Radcliff, criticised your shells through RECREATION. I think you are foolish to try to wreak your vengeance on Mr. Shields. If Mr. Radcliff has made false statements about your goods, I am sure you could have used the same means in replying and demonstrating to the many readers of RECREATION that Mr. Radcliff did misstate facts about your shells. The course you are pursuing will certainly convince all those who are not familiar with your shells that Mr. Radcliff told the truth about them. Why do you not invite Mr. Radcliffe to publicly demonstrate the truth of his assertions? It certainly would not cause either of you much inconvenience and it would settle this matter amicably.

F. J. Forquer.

## FREE BOOK, WEAK MEN



My illustrated nature book on losses varicocele, impotency, lame back, free sealed, by mail. Much valuable advice and describes the new DR SANDEN HERCULEX ELECTRIC BELT. Worn nights. No drugs. Currents soothing. Used by women also for rheumatic pains, etc. 5 000 cures 1902  
Established 30 years. Advice free.

**DR. G. B. SANDEN,**  
1155 Broadway, N. Y.

**MENNEN'S BORATED TALCUM TOILET POWDER**

TRADE MARK

A Positive Relief For PRICKLY HEAT, CHAFING, and SUNBURN, AND ALL AFFLICTIONS OF THE SKIN.

"A little higher in price, perhaps, than worthless substitutes, but a reason for it." Removes all odor of perspiration. Delightful after Shaving. Sold everywhere, or mailed on receipt of 25c. Get Mennen's (the original). Sample Free.

GERHARD MENNEN CO., Newark, N. J.

# Stings

# Cuts

# Burns

# Bruises

For the ills and accidents of camp and trail. There is no emergency remedy so valuable as Pond's Extract, *the old family doctor*. The dependence of the Pioneer 60 years ago—the panacea that cured the ills and saved the lives of the old Forty Niners. Used to-day on battlefield and battleship; in hospital and home. Endorsed by physician, nurse, sportsman and guide.

CAUTION—Don't risk your life on cheap witch hazel. If you want water dip it from the brook.

*Pond's Extract is sold only in sealed bottles with buff wrapper.*

## POSTERS AS POT BOILERS.

Photographers neglect opportunities of making money. One of the largest fields as yet untrodden by the photographer is that of poster making, or poster designing. There are a few large half tone blocks of plump babies, fed on somebody's food, to be seen on the hoardings, and now and then one sees a huge portrait of a would-be dramatic star appearing at a suburban theater, but that is all. Think of the scope there is for designs for tea, tobacco, cocoa, condensed milk, and the hundred and one commodities that are advertised, for which photographs could be utilized. A photograph of an old Dutch woman in a cottage drinking a cup of tea would make a most admirable poster design; and there are thousands of photographs in the hands of amateurs that would be suitable for similar purposes. Portraits of people who would object to the publicity should not be used, for that would be an unpardonable breach of good taste; but without giving offense to anyone there are many subjects which could be utilized, and for which advertisers or advertising contractors would pay well.—Amateur Photographer.

Aunt Jane (to Bobby, who has had a fall)—Oh, I wouldn't cry, Bobby.

Bobby—Of course you wouldn't; and I wouldn't cry if you fell down.—Boston Transcript.

A group of young girls were on their way home from the park, where for several hours they had been enjoying the excellent skating. All but one of them were experts. That one was a beginner, and her afternoon had not been wholly devoid of the beginner's usual experiences.

The girls, looking the picture of health, boarded a home-bound car. With a single exception, they all managed to secure seats. The exception was the girl who had just had her first experience on skates.

She had stood only a moment, however, when a gallant youth rose and politely offered her his seat. She acknowledged the courtesy with a pleasant bow. "Thank you, sir," she said, "but I have been sitting all the afternoon."—Philadelphia Telegraph.



## ARNICA

### Tooth Soap

*the International Dentifrice*



Beautifies the teeth, hardens the gums, sweetens the breath. Preserves as well as beautifies the teeth. Comes in neat, handy metal boxes. No powder to scatter, no liquid to spill or to stain garments.

**25 Cents**  
At all Druggists.

**C. H. STRONG & CO., Proprietors,**  
Chicago, U. S. A.



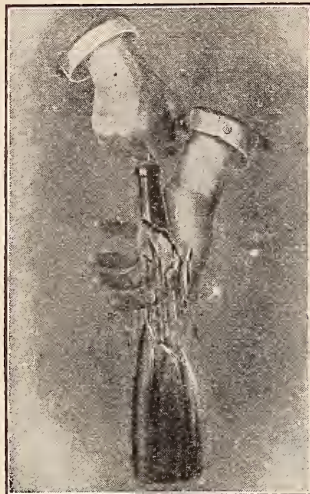

Don't wait until your wife or servants Cut Their Hands

BUY A  
**Yankee Cork Puller**

An up and down motion of the handle draws the tightest cork and automatically discharges it. No effort. No trouble. No broken bits of cork left in the bottle. Never slips. Lasts a lifetime. Fastens to sideboard, door-jamb or other upright surface. Cannot get lost.

*Ask the hardware dealer, or sent direct, express prepaid, on receipt of price.*

BOOKLET FOR **Nickel Plated - \$1.25**  
THE ASKING **Silver " - 3.50**

After 30 days' trial, the money cheerfully refunded if not pleased

**THE GILCHRIST CO.**

125 Lafayette St.

Newark, N. J.

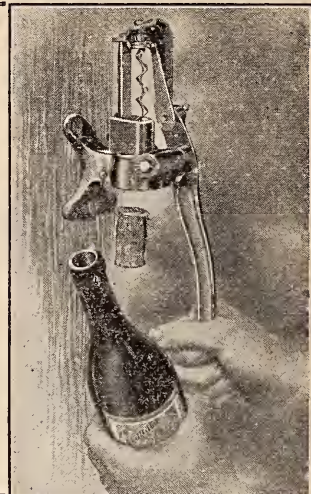

### ONE DEER AT ONE SHOT.

I had been sick with scarlet fever, and as I grew better the doctor informed me that I could not attend school till after Christmas. A week later my father received a letter from his brother, who lived on a small farm up in the backwoods of Maine.

Uncle John wrote that as I could not attend school, and as I had never been at his home, he would like to have me spend the fall with him; that game was uncommonly abundant, and he would warrant me a shot at a deer within a week after I arrived. I was, of course, anxious to go and after a little my parents consented.

A letter was sent to Uncle John and a day later I followed it with a brand new rifle and plenty of ammunition. After a long and tiresome journey I left the train at a small station and found Uncle John awaiting me. We were soon in the spring wagon, driving swiftly over the somewhat rough roads. Shortly after dark we arrived at Uncle John's home, where I was greeted by my cousin Joe, a genial lad with a frank, open face, and we were soon the best of friends.

Next day was rainy and the deer hunt my uncle had promised me did not take place. I spent the day shooting at a mark and helping Joe husk corn. My uncle was delighted with my new Savage, and declared it the finest gun he had seen. I made him a present of it when I returned home.

Early the second morning I was awakened by Joe, and we hustled around doing the morning chores. On my asking where his father was Joe replied that he had gone to stir up the game. Soon after sunrise, with a lunch in our pockets and our guns in our hands, we were legging it through lots and over fences making for a small lake 2 miles from the house. After 20 minutes of rapid walking we reached the lake and Joe left me at the lower end, telling me to watch the woods and lake both and to keep cool if I saw anything. I promised and he started off up the lake, soon disappearing in the brush.

Left to myself I fell to thinking what I would do in case I should see a fine buck with huge antlers running toward me through the woods. I sat for some time watching the woods as a cat would watch a straw stack out of which she expected to see a rat run. At last I turned my attention to the lake and studied its calm surface. Out on the water, close to the farther shore, were 2 small black spots which I at first took for stumps. Suddenly I thought I could see them move. I strained my eyes. Yes, slowly but surely, those spots were nearing the middle of the lake.

They were coming toward me, and before long I could see the shape of their heads. They were deer. A buck; I could see his horns; and a doe. Nearer and nearer they came. I was surprised to find myself so cool. I never felt steadier when shooting at a rabbit.

They were almost in to the shore. I believe I could have killed either one; but I was cool enough to wait another minute, until they reached shallow water and were walking out. I drew a bead on the buck and waited until his body was out of the water, then fired. He gave a sharp snort, made a furious bound, and fell splashing into the water. The doe turned quickly into the water again, the bullet I sent after her skipping along the surface of the lake. I sprang into the water and taking the dead buck by the feet dragged him to shore. I picked up my rifle and as I did so I heard the report of Joe's rifle as he fired at the doe. After 3 shots he gave it up, as she kept all but her nose under water. Joe and Uncle John soon joined me and heartily praised my shot. That evening I partook of my first venison and went to bed tired but happy. I had killed my first deer with one shot.

Herbert A. Robinson, Fabius, N. Y.

He (very stout)—I can not express myself!

She (looking at the clock)—Oh, hum; well, go by freight, then.—Philadelphia Bulletin.

# THE HOME OF PABST BLUE RIBBON

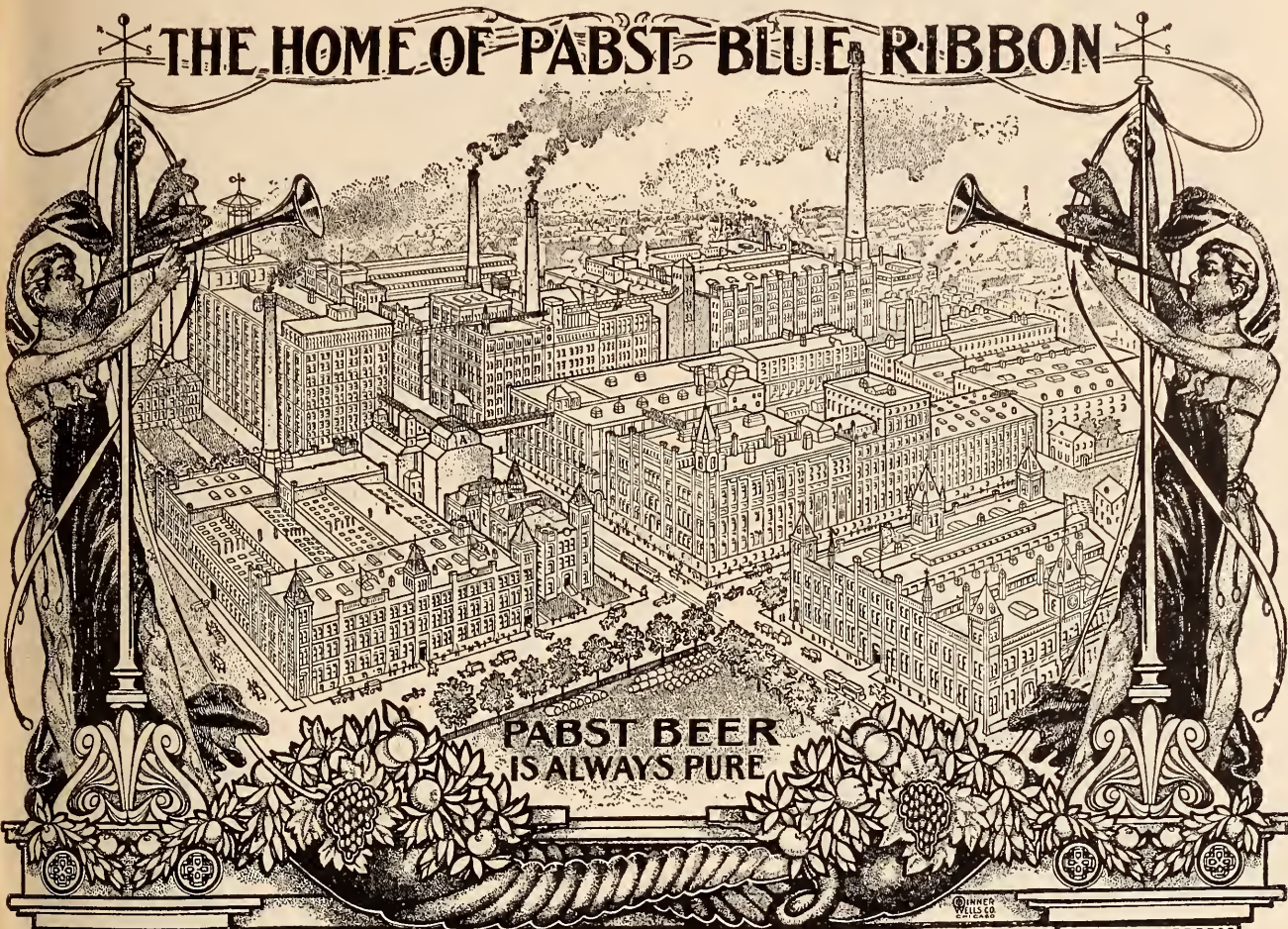

Sixty years ago, a single, insignificant building.

Today, a city in itself.

That's the history of the great Pabst Brewery.

Story by story—building by building—block by block—it has steadily grown to its present vast proportions.

That growth is due to the Pabst art of brewing good, pure, wholesome malt beer.

The beer that agrees with everybody.

And *Pabst Blue Ribbon* is the beer of undisputed quality—of unparalled popularity.

# DO YOU WANT A LENS?

**If so, why not get a good one?  
And why not get it free of charge?  
This is easy.**

Any old box will answer the purpose if it does not leak light; but you must have a fine lens to make a fine picture. You can get

## **A Royal Anastigmat Lens, 4x5, Series No. 1**

Made by the Rochester Lens Co., Rochester New York,

**And listed at \$45,  
For 20 yearly subscrip-  
tions to RECREATION**

You can get any other lens made by this Company on a basis of one subscription to \$2. of the list price of the lens.

Sample copies of RECREATION for use in soliciting furnished on application.

### REMARKABLE OFFERS

To every person who will send RECREATION \$1 for 1 year's subscription to be placed to my credit I will give as a premium a choice of a Nickel Plated Match Safe, or a Gilt Metal Match Safe, or a Hard Rubber Water Proof Match Safe, each listed at 40 cents; or a Nickel Dog Whistle and pocket drinking cup, listed at 50 cents; or a Nail Clipper, with file and Nail Clipper attached, listed at 40 cents; or a 25 yard Single Action Reel, listed at 40 cents; or a 25 yard Water Proof Silk Line, listed at 50 cents.

For 2 subscriptions a Hunting Knife, Stag Handle, Blade 5½ inches long, listed at \$1.

For 3 subscriptions a Patent Double Minnow Bucket, listed at \$2; or a 60 yard Multiplying Reel, listed at \$2; or a 3-piece Bamboo Rod, 7 or 9 feet long, listed at \$2; or a Heavy Silk Watch Fob, listed at \$1.50.

For 5 subscriptions a fancy striped Hammock, listed at \$3; or a Hunting Knife, listed at \$3; or a Tackle Box, listed at \$3.

For 9 subscriptions a field glass listed at \$6.

Only a limited number of subscriptions can be accepted on these offers.

E. W. Jacobs, Coshocton, Ohio.

**IN ANSWERING ADS PLEASE  
MENTION RECREATION.**

### WHY NOT EARN ONE?

I beg to acknowledge receipt of the wall tent and Marble Safety ax sent me as premiums for subscriptions to RECREATION. I have found the goods exactly as represented, made of the best material and in the best possible manner. The manufacturers are to be congratulated on the goods they are putting out, and RECREATION readers should certainly congratulate themselves on the opportunity you offer them to receive these fine camping necessities for the little trouble of taking a few orders for your magazine. I thank you for your kindness and courtesy.

A. E. Chase, Brunswick, Me.

I wish to acknowledge the receipt of the beautiful gun cabinet made by the West End Furniture Company and given by you as a premium for a club of RECREATION subscribers. If the readers of RECREATION knew how easily they might own one of these cabinets there would be few of them without one. It is absolutely no trouble to raise a club of 25 subscribers for the best of all sportsmen's publications.

L. E. Sexton, Sandy Hill, N. Y.

The J. C. hand trap you sent as premium for 5 subscriptions arrived safe. We had a shoot on Memorial Day and used the trap to throw about 400 targets. It worked like a charm.

Wm. Martini, Canajoharie, N. Y.

I received the Forehand revolver and the cartridge belt as premiums. Am glad I worked for them, as they are worth 10 times the trouble it was to get the subscriptions.

C. C. Graves, Glen Ridge, N. J.

I received the Harrington & Richardson automatic revolver from the manufacturers very promptly. Have tried it and found it O. K. Thank you for same.

L. R. Cogswell, Somerville, Mass.

I received the Century No. 10 camera that you sent me as a premium, and am delighted with it. Have tested it thoroughly and find it far above my expectations.

C. Schafer, Philadelphia, Pa.

I am in receipt of a Laughlin fountain pen sent me as a premium and am much pleased with it. I have used several makes of fountain pens, but this one is best.

T. J. Cooper, Grand Rapids, Wis.

The gold chain and charm you gave me as premiums are beauties, and I am more than pleased with them.

Peter Lauridsen, Bridgeport, Conn.



# Help Yourself

**To and with The Only  
Natural Porous Food  
Made From Wheat**

Split, toast and try it as bread. A delicious combination with preserves and fruits. Makes ideal fruit short-cake and tempting dishes when combined with mushrooms, sweetbreads or vegetables.

## SHREDDED WHEAT BISCUIT

**Can Be Prepared In Over 250 Different Ways**

It is a remarkable fact that no other food takes the place of *Shredded Wheat*. This is true because in it the complete requirements of the body are found—the identical food counterparts of the human organism—it's *perfect food affinity*.

Cook Book artistically illustrated in colors, "The Vital Question," sent **FREE** upon request. Address

**Natural Food Co., Niagara Falls, N. Y.**

Gavena Galloway, White Water, Wis., writes:

"We use Shredded Whole Wheat Biscuit for breakfast, as dessert for dinner, toast for tea, and for chafing dish luncheons in the evening and would not be without it."



145

### THE FADING OF PLATINOTYPES.

The hitherto assumed absolute permanency of platinotypes is being questioned, and it is urged that even the most carefully prepared prints show discoloration in less than 12 months. However, the platinotype made with ordinary care is the most permanent of photographic prints. It is true that platinotypes, like prints made by other processes, exhibit remarkable differences in respect to fading, and that some will discolor in a few months, while others are unaltered after many years. A case of this kind happened to a professional photographer. He was suddenly faced with discolored platinotypes, a thing he had not before encountered during many years' experience. Investigation proved that it was a question of mounts, since prints from the same batch quickly discolored on one special mount, and not on others. This is often the cause of alleged fading with processes which, under ordinary conditions, are undoubtedly permanent.—The Photographic Chronicle.

The handiest receptacle for stocking quarter-plate negatives is a cigar box of the kind in which hundreds are sold. A strip of grooved card or paper glued along each side will serve for slots to keep the plates in position. Most of these boxes are the correct size.—Exchange.

Spokane, Wash.

The Peters Cartridge Co.,

Cincinnati, Ohio:

Gentlemen:—I note in May RECREATION your action in withdrawing your advertisement therefrom on account of its publishing a communication reflecting on your ammunition. I am surprised that a house of your standing should take a position so manifestly unfair. If advertisers are to hold a club over editors, so that subscribers can get only one side regarding the merits of the articles they advertise, such magazines would be useless to subscribers. Any old thing described in their advertising pages would go, and the purchasers would only learn by costly experience of their defects. I would not take any magazine that I thought was so controlled.

F. S. Merrill.

A little girl was heard talking to her rabbit.

"Five times 5," she said; 6 times 6; 7 times 7." Between times she shook the rabbit violently.

"Dorothy," said her mother, "what are you doing to your rabbit?"

"Well, papa says," replied the child, "that rabbits multiply rapidly and Bunny won't do it."—Town Talk.

**IN ANSWERING ADS PLEASE  
MENTION RECREATION.**

# Underwood's Original DEVILED HAM

LOOK ON THE CAN FOR  
THE LITTLE RED DEVIL

The pure and delicate Deviled Ham which has been on the market for years and years, and never found wanting. Sugar-cured ham and fine, pure spices is all that we use. It is delicious for sandwiches, at lunch, picnic, or tea, and in the chafing-dish. Our Book contains a lot of unique and practical receipts. We will send it FREE.



## UNDERWOOD'S ORIGINAL DEVILED HAM

may be bought at any good grocer's, but be sure you see on the can **THE LITTLE RED DEVIL.**  
Wm. Underwood Co., Boston, Mass., U.S.A.

A cleansing fluid for grease spots, which may be found useful in photographic work-rooms and studios, can be made as follows:

Oil of turpentine.....	4 ounces
Ammonia .....	4 "
Spirit of soap (methylated).....	2 "
Acetic ether.....	2 "
Alcohol (methylated).....	2 "

After mixing, it is ready for use. When put aside, the compound will require shaking before application.—The Photo-American.

I, also, have had trouble with Peters' cartridges, through their jamming in the action of a brand new Winchester. Therefore the trouble lies wholly with the cartridge, not the gun. I have a number of Peters' cartridges so imperfectly made that they will not enter the rifle chamber. The new Winchester smokeless, greaseless .22 cartridge can not be praised enough. The one I have is in good condition after 8 years of hard usage.

G. Tuchband, Chicago, Ill.

## Here is Another!

If you will send me

30 Yearly Subscriptions

to

# RECREATION

I will send you

## A No. 10 Goerz Trieder- Binocular Field Glass

Listed at \$38.00

Every well-informed man knows the great power of this modern prismatic field glass. It is indispensable to every hunter, and is one of the latest and best on the market.

I have but a few of these instruments on hand and the offer will be withdrawn as soon as the supply is exhausted. Therefore, if you want one

**START IMMEDIATELY.**

Sample copies of RECREATION for use in canvassing furnished on application.

"There is a little matter to which The Messenger begs to call the attention of some of its subscribers. We really hate to speak of it, but some have seemingly allowed it to slip their mind. To us this is an important issue; in fact, it is necessary in our business. We will not speak further on the subject. Perhaps you have already guessed the drift of our remark."—Minneapolis Messenger.

I am heartily in sympathy with your efforts toward game protection. The timber squirrel should no longer be considered a game animal. In this locality there are not one-sixth so many squirrels as there were 10 years ago. Many men in this vicinity shoot squirrels and call it sport.

W. J. Armstrong, Canton, Minn.

IF YOU WOULD LIVE NEXT TO  
NATURE, READ RECREATION.

## Reduce Your Fat



but don't ruin your stomach with a lot of useless drugs and patent medicines. Send to Prof. F. J. Kellogg 678 Kellogg Building, Battle Creek, Michigan, for a free trial package of a treatment that will reduce your weight to normal without diet or drugs. The treatment is perfectly safe, natural and scientific. It takes off the big stomach, gives the heart freedom, enables the lungs to expand naturally, and you will feel a hundred times better the first day you try this wonderful home treatment.

## THAT BLACK FOX.

When I reached the trapping age, we lived on a farm in North Dakota, with plenty of room to look out for signs. At one time an old sandpit, on the top of a large hill, showed signs of habitation, the South side being lined with holes of all sizes. The traps were set and covered with tissue paper; and a thin layer of sand was scattered over all.

The next afternoon Bill and I went again. Approaching the North side of the pit, we looked over in time to see a scurry of black and hear the rattle of the chain as some trapped animal attempted to escape.

"Bill," I shouted, "it's a black fox!"

"Gee! They sell for a whole lot, don't they?"

"You bet," I answered, but how to get the beast was the main question. I had never had much experience with black foxes. Neither had Bill. I did not know but they might be dangerous. We decided that Bill should get over on the South side just above the trap, lean over, twist his axe blade in the trap chain, and drag the fox out for me to shoot.

The plan worked well. Bill pulled and strained at his axe handle, a black form rolled unwillingly out, and I blazed away.

About that time a pale blue smell arose. At first it was light and feathery, like heat from the kitchen fire on winter mornings, but it developed power and grandeur until it rolled forth from that old sandpit like lava from Mont Pelée. The dog moved off down the hill and viewed us disconsolately. He was a well bred animal.

"Gee!" yelled Bill; "does black foxes smell like this?" Bill was from town, you see, and didn't know.

"No," I shouted, hitting the high places as I ran, "but skunks does."

Floyd T. Wood, Fargo, N. D.

IN ANSWERING ADS PLEASE MENTION RECREATION.



# Club Cocktails

Famous the world over for purity. They never vary. The secret of their perfect blend is that they are kept six months before being drawn off and bottled. Be sure you have them in your camp, on the yacht, and on your outing trips wherever you go. They are ready and require no mixing. Simply pour over cracked ice.

For Sale by all Fancy Grocers and Dealers

**G. F. HEUBLEIN & BRO.**  
29 BROADWAY, N. Y. HARTFORD, CONN.

I bought an Eastman kodak, 4 x 5, having seen them advertised in RECREATION. I think everything advertised in your magazine must be of the best, and so far as my experience goes such is the case.

W. H. Hubbard, Glenwood Springs, Col.

RECREATION is the most entertaining, up to date and conscientious publication of its class anywhere; and one of the brightest of any class in the country.

Edward W. Mason, Council Bluffs, Ia.

No. 58

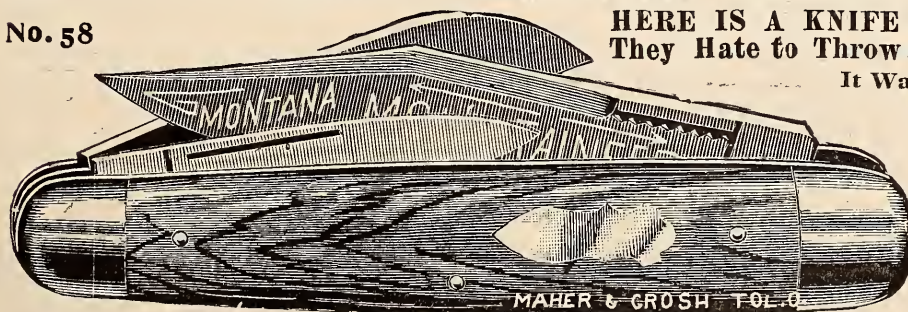

HERE IS A KNIFE Men Love So Much They Hate to Throw an Old Handle Away  
It Was Teddy's Camp Knife!

No. 58. Cut is exact size; ebony handle, 3 blades, German Silver ends. The long blade is for rough or fine work; the medium blade is as thin as a razor. Price, postpaid, \$1, 6 for \$5.

The lower cut is "Chauncey Depew's pet," has three blades (one is a file). Handle is choice selected pearl; German silver, back and ends. Price in chamois case, \$1.50 postpaid. Same knife, 2 blade, \$1; plainer finish, 3 blade, same quality, \$1; smaller 2 blade, for lady, 75 cents. Illustrated 80-page List free, and "How to Use a Razor."

Maher & Grosh Co.  
71A STREET, TOLEDO, O.

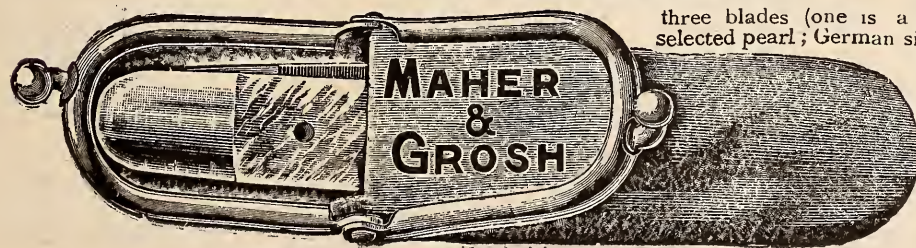



**ROOT'S UNDERWEAR**

**For Men, Ladies and Children**

Root's Camelhair goods are genuine camelhair. Other makes are only "camelhair" in name. Root's Natural Wool goods are made of the combined wools of white and black sheep or lambs, and contain no dyed material. Root's White Wool and Merino goods, sterling value.

Sold by principal dealers in New York and all large cities.  
If not by yours, write to

**Root's Underwear, 1 Greene St., New York**

**Free:** To anyone sending, through me, \$1 for yearly subscription to RECREATION, I will send free a No. 1 Sportsman's Medicine Case; for 2 subscriptions a Physician's Pocket Medicine Case; for 10 subscriptions 1,000 12-gauge primed paper shot shells. This offer is not open to old subscribers who formerly have sent in their subscriptions to the office of RECREATION, but to all others.

Walter Luson, Ardmore, Pa.

I consider RECREATION the best and cleanest sportsman's magazine published in the United States.

Wm. Rowe, Paterson, N. J.

To remove varnish from a negative, place the negative in strong methylated spirit, to which 5 per cent of the strongest liquid ammonia has been added; or a similar quantity of caustic potash can be used. Immerse the negative in this and allow it to soak 10 minutes. Then gently rub the film with a tuft of cotton wool, and immerse in fresh baths of spirit till the whole of the varnish is removed. Wash in water and dry.—Exchange.

I have received the Horton fishing rod you gave me. It is the best rod on Rock river.

B. Knispel, Ebenezer, Wis.

## WEBBER'S HAND-KNIT JACKETS

(Look for Name in Collar Band)



WEBBER'S JACKET

**HAND-KNIT HUNTING JACKET.** Medium, Heavyweight, each \$4.

**HAND-KNIT ALASKA JACKET.** Made with strap across throat, lined pockets and extra heavy, each \$5.

**HAND-KNIT SWEATER, NO. 851.** Made with strap across throat, lined pockets and extra heavy, opens from neck to pockets and double breasted, each \$5.



WEBBER'S No. 851

Made in any Color. Suggest Dead Grass, Oxford Grey, and Scarlet for Deer Hunting. Sent express charges prepaid, on receipt of price. Ask your Dealer for Webber's Jackets

**GEO. F. WEBBER, Manufacturer,**

**Station A., DETROIT, MICH.**

# DIAMONDS ON CREDIT

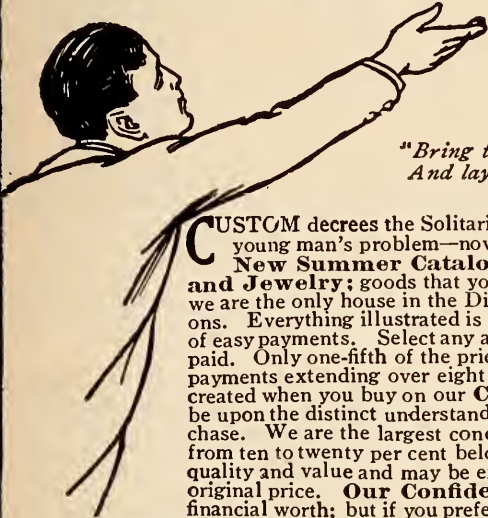

*"Bring therefore all the forces that ye may,  
And lay incessant battery to her heart."*  
—SPENCER.

**C**USTOM decrees the Solitarie Diamond Ring to be the fitting pledge of love. How to get one has been the young man's problem—now happily solved by the **Loftis System** of selling on easy payments. Our **New Summer Catalogue** shows a profusion of the newest goods in **Diamonds, Watches and Jewelry**; goods that you will not find illustrated in the catalogues of other houses until next fall, for we are the only house in the Diamond and Jewelry business which issues a complete catalogue between seasons. Everything illustrated is quoted at exceptionally low prices and sold on the **Popular Loftis System** of easy payments. Select any article that you like and it will be delivered at your door with all express charges paid. Only one-fifth of the price need be paid at first; the balance being arranged in a series of small monthly payments extending over eight months. No security is required; no interest is charged and no publicity is created when you buy on our **Confidential Charge Account System**. If you make a selection it will be upon the distinct understanding that your money will be promptly returned in case you decide not to purchase. We are the largest concern in the business and sell only the finest genuine goods, and at prices ranging from ten to twenty per cent below those of other houses. Every Diamond is sold under a written guarantee of quality and value and may be exchanged at any time in the future for other goods or a larger stone at the full original price. Our **Confidential Credit System** is open to all honest persons without regard to their financial worth; but if you prefer to buy for **spot cash** we make the most startling and liberal offer ever made. It is no less than guaranteeing the return of all money paid at any time within one year—less ten per cent, the reasonable cost of doing business. We are one of the oldest houses in the trade (Est. 1858.) We refer to any bank in America—for instance, ask your local banker to consult his **Dun or Bradstreet** book of commercial ratings and he will tell you that we stand at the top in credit, reliability and promptness. We have a number of attractive booklets that we will be glad to send you if you write promptly for our **New Summer Catalogue**.

**LOFTIS BROS. & CO.** *Diamond Importers and Manufacturing Jewelers*  
**CHICAGO, ILL.**  
 Dept. K-82 92 to 98 State Street  
 Opposite Marshall Field & Company

## PREPARATION OF SELF-TONING PAPERS.

Dissolve by gentle heat 5 grams of previously softened gelatine in 200 cubic centimeters of distilled water, and add by degrees 8 to 10 cubic centimeters of alcohol. Into this gelatine solution drop the following solution:

- Gold chloride..... 0.5 gram
- Lithium chloride..... 1.5 gram
- Distilled water ..... 20 ccm.

To this is further added, in small quantities, and being vigorously shaken, the following solution:

- Silver nitrate ..... 20 grams
- Distilled water ..... 100 ccm.
- Gelatine ..... 5 grams

And finally another addition is made of—

- Sodium citrate..... 3 grams
- Citric acid..... 0.5 gram
- Distilled water ..... 20 ccm.

Spread on a glass plate and squeegee raw photographic paper thereon. After being removed the paper is ready for use.—The Photo-American.

Well fitting corks are difficult to find when required. Cut a V-shaped groove across the middle of the base of the too large cork, and remove the piece. On pressing the ends together, the cork will fit.—Exchange.

## ILLUSTRATING is a Money-Making

profession. We teach you by mail to become an **Illustrator, Ad-Writer, Journalist, Proofreader, Bookkeeper, Stenographer, Electrician, Electrical Engineer, etc.** Write for **Free** illustrated book, "Struggles With the World," and mention the subject which interests you. **Correspondence Institute of America, Box 701, SCRANTON, PA.**



One Cent will save you Hundreds of Dollars

## New York Mail Order House

Your name and address on a postal card will bring you our **Bulletin of Bargains** and **Fashion Sheet** each month. **Write to-day.**

**CUMMINGS & Co. 113-E Sixth Ave., N. Y. City**



## FREE HAIR GROWER

A trial package of a new and wonderful remedy mailed free to convince people it actually grows hair, stops hair falling out, removes dandruff and quickly restores luxuriant growth to shining scalps, eyebrows and eyelashes. Send your name and address to **Altenheim Medical Dispensary, 9301 Foso Bldg., Cincinnati, Ohio**, for a free trial package, enclosing a 2c. stamp to cover postage. **Write to-day.**

## WHAT THEY THINK OF RECREATION

Although only a recent subscriber to RECREATION, I think it is the best with which I am acquainted, and I have read most of the prominent journals devoted to outdoor sport. I do not see how you can furnish such an excellent magazine for the money. All of your readers here speak in the highest terms of it.

H. E. Bartlett, Mt. Sterling, Ill.

Have bought every number of RECREATION since May, 1896. Out of some 9 magazines laid on my desk every month no other receives half the attention RECREATION does. It is read from cover to cover by Mrs. Grey and myself, and our little girl asks regularly for the "pretty red book" with the nice pictures.

H. R. Grey, Danby, Vt.

I note that you published my letter about my red Irish setter; also one on pheasant breeding. I received many letters after that from prominent sportsmen in Pennsylvania, Ohio, Illinois, Minnesota, Michigan, and other States, and was much surprised at the extent of your magazine's circulation.

J. F. Blome, Tomah, Wis.

I get your magazine through my brother, the newsdealer here. I like to see you give it to the thick skinned tribe. There are a number here. I used to be one myself, but, thanks to your magazine, I am one no longer. I have managed to get a few of the boys to quit shooting quails on the ground.

Roswell Puckett, Rock Rapids, Ia.

We have always taken several magazines. Some I never have taken much interest in, but RECREATION strikes me exactly, and I always read it from beginning to end. Every number reminds me of days gone by. Sporting goods houses that do not advertise in RECREATION are making a mistake.

H. M. Tinkham, Cove Forge, Pa.

I am with you, as every true sportsman should be, in trying to educate those who like a day afield to a higher standard of sportsmanship. You are on the right track and I am glad to see someone who is fearless enough to speak the truth about the porkers. They can not be hit too hard.

H. M. Johnson, Batavia, N. Y.

I am glad to see your rapid strides in circulation; also that RECREATION is improving with each issue. It is better to take one first-class sportsmen's magazine than several poor ones. The average business man has not time to read more than one, and so wants the best.

M. K. Barnum, North Platte, Neb.

If the merits of RECREATION itself were not enough to appeal to and win every one who is at all interested in the subjects to which it is devoted, then certainly the liberality of its management ought to make it friends without number.

W. F. Short, Jr., Jacksonville, Ill.

Success to RECREATION. Keep after the hogs. You are doing a world of good, and all good men are with you in spite of the Marlins, the Peters, the Winchesters, and the game and fish hogs.

W. W. Gallaher, Mound City, Mo.

I will send you more subscribers soon, as it is a pleasure to talk RECREATION to my friends and induce them to subscribe for the best sportsmen's magazine in America.

S. M. Eaton, Watertown, Wis.

I take 8 different periodicals, both weekly and monthly, but RECREATION is the leader. The others are fill-ins until the next issue of RECREATION appears.

J. R. Guinn, Philadelphia, Pa.

I am highly pleased with RECREATION. It is the most compact and humane magazine in the interest of the true sportsmen that I have ever read.

J. F. Farmer, Watertown, N. Y.

It is easily seen that wherever RECREATION is taken the friends of game protection increase amazingly.

J. J. Mather, Springboro, Pa.

I am a RECREATION fiend, and there are plenty of others here. Whatever you do, soak it to the game hog.

Otto Turner, Pendleton, Ore.

I can not see how any true sportsman could look at a copy of RECREATION and not subscribe for it at once.

C. E. Confarr, Clifton, O.

I have taken RECREATION 2 years, and it improves with each number.

John E. Goodwein, New Haven, Conn.

Everybody likes RECREATION, and no wonder, as it is the best of its kind.

J. E. Hutchinson, Laconia, N. H.

I pack your magazine on my back 25 miles, so you can see I appreciate it highly.

C. H. Prescott, Kerby, Ore.

I consider RECREATION the best sportsmen's journal in the world.

F. B. Wilson, Philadelphia, Pa.

## The Buffalo Is Well Nigh Extinct

And every nature lover wants a relic of him. Here is a chance to get it:

I have in stock a limited number of buffalo horns, highly polished and fitted with nickel plated flanges at the base, so that they can be screwed on the wall, thus forming

## A Novel and Effective Gun Rack

So long as the supply lasts I will give a pair of these horns for

## 3 Yearly Subscriptions to RECREATION

Sample copies for use in canvassing furnished on request. Address

Recreation, 23 W. 24th St., New York

**Free:** If you send your subscription to RECREATION through me or direct to the office to be placed to my credit, I will send you free of charge, any one of the articles mentioned below:

Shot gun bench crimper, sells for 75 cents, in 10-12-16-20 gauge.

Shot gun cleaning rod, three attachments, sells for 50 cents, in 10-12-16 gauge.

Micrometer powder and shot measure, adjustable, and for both black and smokeless powder, sells for 65 cents.

U. S. Government rifle cleaner, any caliber, with attachments, sells for 60 cents, packed in neat canvas bag.

A duck, snipe or turkey call, sells for 75 cents each, best made.

A hand painted sporting picture, suitable for framing and just the thing for your den, worth \$1.50.

"Hunting in the Great West," by G. O. Shields. H. S. Hill, 815-11th Street. N. E., Washington, D. C.



## Lovely Complexion FREE.

A Trial Package Mailed FREE which will give any lady a beautiful complexion. It is not a face powder, cream, cosmetic or bleach, but is absolutely pure and you can use it privately at home. It permanently removes moth patches, redness, crow's feet, pimples, blackheads, fleshworms, sallowness, freckles, tan, sunburn, and all complexion disfigurements.

MADAME M. RIBAUT, 5254 Elsa Bldg., Cincinnati, O.

For Early Fall

# Jaeger

PURE WOOL UNDERWEAR

The Standard Sanitary Woolens for Men, Women and Children.

Special Light Weights for this Season

ILLUSTRATED CATALOGUE FREE showing also our various Jaeger articles

DR. JAEGER S. W. S. CO'S. OWN STORES  
NEW YORK: 306 Fifth Ave., 155-157 B'way

BROOKLYN: 504 Fulton Street

BOSTON: 230-232 Boylston Street

PHILADELPHIA: 1510 Chestnut Street

CHICAGO: 82 State Street

AGENTS IN ALL PRINCIPAL CITIES

The Celebrated

# THOMPSON-QUIMBY

Hunting Boots, Shoes and Moccasins

T H O M P S O N



P S O N

I have on file measurements of all who bought Boots and Shoes of the W. Fred Quimby Co., of New York for the past 20 years, and I make the same grade of sportsmen's footwear as they made. I was superintendent of the shoe department of that firm and bought the right to make these boots and shoes. Get a pair now. They will last years and are the cheapest in the end. I refer by permission to the Editor of RECREATION.

Measurement blanks and prices on application. Mention RECREATION.

**T. H. CUTHRIE**  
33 William Street, NEWARK, N. J.

All Work Guaranteed

# DO YOU WANT A FOLDING CANVAS BOAT ?

If So, Send Me

## 35 Yearly Subscriptions to RECREATION

AND I WILL SEND YOU

**A 14 ft. King Folding Canvas Boat**

**LISTED AT \$48**

capable of carrying 2 men and an ordinary camp outfit. There are thousands of these boats in use, and nearly every man who is using one of them praises it on every occasion.

Sample copies of RECREATION for use in canvassing will be furnished on application.

**Address 23 West 24th St., New York**



## DEFECTIVE NEGATIVES.

One of the most troublesome drawbacks the amateur has to contend with is fog. It may happen that one has a negative which appears satisfactory in all ways but one, and that one defect is an appearance of slight general fog all over the film. This may be due to the defective light in the dark room; to some stray light which has got to the plate while changing when on a journey; or it may have been caused by a general spreading of light which has got to the exposed plate through a steamy lens, as when exposing on a bright subject in cold, damp weather. Again, it may be caused when exposing on a bright cloud, where the brilliant light illuminates the interior of the camera far too much.

If we prepare a solution of perchloride of iron, 10 grams in an ounce of water, and, after soaking our negative in cold water a few minutes until the gelatine feels soft, we pour off the water and flood the plate with the iron solution about half a minute, after draining we shall probably find that the fog has gone. It is then advisable to rinse the plate in water and transfer it to a clean fixing bath for 5 minutes.

Foggy negatives are caused by an unsafe light, too much light, decomposed developers, contaminated dishes, traces of hypo, over exposure or under exposure, and too much forcing with alkali.

If the plate is fogged, and yet the edges are clean, the plate is most probably over exposed. Too great a density with still, clear shadows means under exposure.

Black spots are often produced by dirty dishes.

In the case of metallic or iridescent stains, which are often seen when plates are stale or have been kept in a bad atmosphere, perhaps the best plan is to take a fine rag, and having dipped it in methylated spirit, rub gently with the tip of the finger, changing the rag surface as it becomes discolored.

When negatives show signs of frilling, it is a good plan to add a little Epsom salts to the washing water. If there is any reason to expect that the plate may frill, it may be immersed in a solution of Epsom salts previous to development.

If the plate is not rocked during the process of development, we are likely to get markings of a mottled character. These are most difficult to remove, and often can not be remedied.

The small circular spots which are seen often on negatives due to tiny air bells are easily avoided by flooding the plate with an even flow of developer. The preliminary soaking of the plate in water is a fruitful source of air spots. When they threaten, the plate should be wiped with a plug of wool wet with developer.

For the yellow stain caused by development, a solution of iron sulphite, 3 ounces in 20 ounces of water, with an ounce each of sulphuric acid and of alum, is useful.—F. G., in Photo-American.



**What  
One  
Side  
Gives**

**The  
Other  
Side  
Takes**

*The*  
**"Give and Take"**  
**Principle**  
*of the*

**President  
Suspender**

gives ease to every movement  
and comfort to the man.

50c and \$1 at any shop or by mail.  
Buckles cannot rust.

**Absolutely Guaranteed.**

**C. A. EDGARTON MFG. CO.**  
Box 219 Shirley, Mass.



## Shooting Jacket

### \$3.00

**G**UARANTEED all wool, seamless, elastic, close fitting, but not binding, comfortable and convenient. Designed especially for duck shooters, trap shooters, etc., but suitable for all out-door purposes. Must be seen to be appreciated. Made only in two colors—dead grass and Oxford Gray.

Send us your address for one of our Gun Catalogs.

**The H. H. KIFFE CO., 523 Broadway, N. Y.**

**Free:** To anyone sending, through me, \$1 for yearly subscription to RECREATION, I will send free a No. 1 Sportsman's Medicine Case; for 2 subscriptions a Physician's Pocket Medicine Case; for 10 subscriptions 1,000 12-gauge primed paper shot shells. This offer is not open to old subscribers who formerly have sent in their subscriptions to the office of RECREATION, but to all others.

Walter Lusson, Ardmore, Pa.

New York.

Messrs. Wing & Son:

I am more than pleased to add my praise of your celebrated piano. It is everything you claim it to be; its quality of tone is easy and quick, and the instrumental attachments are most perfect. As one who knows from experience, I subscribe myself an admirer of the Wing piano.

Lawrence R. Kerr,  
Proprietor Putnam House.

## TWO BUTTON INVISIBLE SUSPENDER

No Attachments Required. The Wonder of the Age



Worn over or under any shirt made. Pivoted over hip. One pair sufficient for all trousers. Prevents trousers from bagging at the knees. Easily adjusted to large or small men. Long or short waisted. They act as a shoulder brace. Ease, comfort and no strain. The only practical suspender made for summer use.

Postpaid, anywhere in the U. S. \$1.00.  
**TWO BUTTON SUSPENDER CO.**  
Manufacturers and Inventors  
Dept. R BINGHAMTON, N. Y.



**A Hunting Knife Free.** To any person sending me three yearly subscriptions to RECREATION and \$3, I will send a pocket hunting knife with handle 5½ inches long and a blade 5 inches long. Fine steel, excellent workmanship. Your name and address and your L. A. S. number if desired inserted on a plate in the handle.

Geo. W. Mains, McKeesport, Pa.

**For Exchange:** Violin, cost \$20., perfect condition, for repeating rifle. Give make, caliber and condition. Also, Wizard B. Camera, 5 x 7, plate holders and case, like new. What do you offer?

Lock Box 39. Youngsville, Pa.

**For Sale:** Winchester, Box Magazine, Fancy Sporting Rifle, model 1895, 30-40 U. S. A. In good condition, a magnificent weapon. Price, \$20.

I. P. Taft, Box 474, Norwich, Conn.

**For Exchange**—100 copies of RECREATION, years 1896 to 1903, for best offer of Indian arrow and spear heads, and stone hatchets. Arthur Sussman, Long Branch, N. J.

**For Sale:** Lefever 12 gauge, 2 sets barrels, fine case and full set Ideal reloading tools for same. Write for particulars and price. Dr. J. A. Bliss, Ruthven, Iowa.

**For Sale.** Pope-Winchester rifle, telescope sight, muzzle loading outfit, set trigger, etc; also field glasses. M. G. W., care of RECREATION.

**For Sale.** Mullins' Get There Duck Boat. Never been used. Wm. B. Haverstick, Mountville, Pa.

**For Sale or Exchange.** Tallyho Coach. H. B. Fischer, Pittsfield, N. H.

Korona camera received. I am more than pleased with it. Tried it yesterday and found it beyond my expectations. This is the first time I ever got something worth having, for nothing.

Chas. A. Phillips, Randolph, Mass.

I have been an ardent reader of your magazine ever since it was first published and have, at this time, a complete file that money could not buy.

F. C. Godley, Portland, Ore.

**FREE.** To anyone subscribing to RECREATION through me I will give a cloth copy of one of Cooper's, Dickens', Dumas', Thackeray's or Conan Doyle's books. Address,  
J. M. RUGEN, 2103 West Lake St., Chicago, Ill.

IF YOU WOULD LIVE NEXT TO  
NATURE, READ RECREATION.

The Reason the LUTHER HAND-MADE GLOVE will not rip



Machine sewing cuts itself



Hand sewing cannot.



## A Practical Hunting and Driving Glove

Made for practical, comfortable, durability. No Oil. No Odor. No Animal Glue. Practically seamless, Cannot Rip. Unaffected by moisture of any kind. If soiled, may be washed with soap and hot water, without injury. The Luther Fastener is adjustable, fits any wrist and cannot get out of order. Illustrated booklet, samples and self measurement rule on application.

If you prefer to buy through your dealer send us his name

**No. 308 Driving Glove** postpaid anywhere **\$7.50**, made to measure **\$2**  
**No. 320 Gauntlet**, " " " " **2 50**, " " " " **3**

**J. P. LUTHER GLOVE CO., 536 Pearl St., Berlin, Wis.**

**To RECREATION Readers:** I am organizing a club of subscribers for RECREATION, with a view to securing a premium, and I submit this offer; to each person sending me \$1 for yearly subscription to RECREATION, I will send a 25c. Dominion of Canada bank note. There are but a few of these in circulation and I have succeeded in collecting a number of them. These are interesting souvenirs and are especially valuable to persons who are making collections of coins or other curios. Walter Legare, 518 John St., Quebec, Can.

### A DOLLAR RATE BOOK FREE *To Advertisers*

We will send postpaid, entirely without charge, to any business house that is interested in the subject of advertising, a copy of a bound volume we have recently issued entitled "Current Rates of Live Publications," giving list of leading towns throughout U. S., populations, principal papers, circulations and publishers' rates for advertising space on small and large contracts. Regular price of this volume is \$1—We will send free upon receipt of ten cents in stamps to cover postage.

**FULFORD, PAINTER & TOBEY, Inc., Advertising Agents**  
 N. W. Cor. Wabash Ave. and Randolph St. CHICAGO, ILL.

My ad in RECREATION has been astonishing in its results. I have received offers from nearly every State in the Union and the end is not yet in sight.

C. F. Sundy, Hayti, S. D.

## How is your Muscle?

Would you like to build it up?

## How are your Lungs?

Would you like to expand them?

## How is your Circulation?

Would you like to improve that?

If so, send me **10 yearly subscriptions** to RECREATION, accompanied by a money order for \$10, and I will send you a new

## PROFESSIONAL PUNCHING BAG

made by **H. D. CRIPPEN**, No. 52 Broadway, New York and listed at \$6.95.

There is a frame with the bag that you can attach to a door casing, a window casing or a wall, or a board fence, or anywhere else you may see fit to put it, and you will thus have a small gymnasium of your own. The Crippen bag is one of the liveliest ever devised, and if you will put 20 minutes a day on it, for a month, you will find a wonderful improvement in your muscle and your health.

Sample copies of RECREATION, for use in canvassing, will be mailed free.

## SQUIRES' SIBERIAN MOOSE HUNTING BOOTS & SHOES

Made only by **HENRY C. SQUIRES & SON**  
 20 Cortlandt St., New York

The leather is waterproof, fine grained, tough and pliable. The linings are russet calfskin. The soles are best waterproof anhydrous oak leather, stitching of silk, English back stays, bulldog toes, extra heavy eyelets, Pratt fasteners and hand made throughout. Price **\$7.50** net. Short Boots **\$8.50**, Knee Boots **\$10**, Cavalry Style Boots **\$12**. Special circular giving detailed information free for the asking.



Mention RECREATION.



**One Hand Controls THE DURYEA**

No bewildering array of levers, gauges or other intricacies— one hand does it all. A twist of the wrist not only steers it, but accelerates or retards the pace from a position of luxurious ease. **THE DURYEA PHAETON** is the acme of motor carriage perfection. Its long springs and large wheels obviate all jar and give greatest possible comfort. No machinery in front to annoy passengers by odor, or in sight to mar appearance. The result of twelve years' experience of the oldest motor vehicle builders in America. Triple Gasolene Motors. Speed up to 40 miles per hour. Fuel for 100 mile run. Large bronze bearings.

Duryea vehicles are most durable and economical in fuel and tires of any built. **No pumps, no trouble.**

Duryea's excel under all conditions.

Fastest American gasolene carriage, Nelson Hill, 1901; won Chicago Times-Herald 50 mile race through more than a foot of snow, and other races in Europe and America. They lead the way today.

Send for catalogue of the eight styles—also booklets. They will interest you.



**DURYEA POWER CO., 314 Hockley St., Reading, Pa.**

# The Rocky Mountain Goat

Is a shy, wary animal that ranges 8,000 to 15,000 feet above sea level

and has rarely been photographed, Mr. A. M. Collins, one of RECREATION's prize winning photographers has recently made 4 of the finest goat pictures ever produced. I HAVE had enlargements made from these, 13 x 15 inches, and will sell them

**At \$5.00 a Set.**

A rare and valuable group for sportsmen, amateur photographers and nature students. Address

**RECREATION, 23 WEST 24th ST. NEW YORK CITY**

**Free:** For 1 year's subscription of RECREATION, through me, will give 1 Bromide enlargement, any size up to 11 x 14 inches, inclusive, from any negative not larger than 4 x 5; or from photographs. Negatives and Photos are to be returned to the owner. Here is a rare chance to get a large Photo from your pet Negative, also RECREATION for \$1. A. F. Evarts, Meriden, Conn.

### White Mountain Views Free

To any person sending me a subscription to RECREATION accompanied by \$1. I will send two mounted photos, on velox paper taken among the White Mountains, size 6x8; one shows Mt. Washington snow capped. To any one sending 2 subscriptions with \$2 I will send a souvenir of the White Mountains, size 4½ x 5½ containing seven photos. Send P. O. Money Order.

**M. E. TUTTLE, Box 337 Dover, N. H.**

# PATENTS

promptly obtained **OR NO FEE.** Trade-Marks, Caveats, Copyrights and Labels registered. **TWENTY YEARS' PRACTICE.** Highest references. Send model, sketch or photo, for free report on patentability. All business confidential. **HAND-BOOK FREE.** Explains everything. Tells How to Obtain and Sell Patents, What Inventions Will Pay, How to Get a Partner, explains best mechanical movements, and contains 300 other subjects of importance to inventors. Address,

**H. B. WILLSON & CO.** Patent Attorneys  
786 F Street, N. W., WASHINGTON, D. C.

### AN AUTOMATIC FILTER.

To filter considerable quantities of solution, fill a quart bottle with the liquid to be filtered, and fit tightly with a cork, into which insert 2 pieces of narrow glass tubing, both pieces projecting about 2 inches outside, while inside the bottle one piece should pass to the bottom, and the other stop short with the cork. Next take a funnel, and either a paper filter or a plug of cotton wool, according to whether the insoluble matter or the filtrate is the portion to be kept, and having placed a suitably sized receiving vessel underneath, place a finger over the open end of the long glass tube, invert the bottle over the filter, and fix in such a position that the glass tubes projecting from the cork dip down about ¼ inch into the funnel. On removing the finger, the liquid, of course, runs into the funnel, until it has risen high enough to stop the air passing up the long tube, and so stop further outlet from the bottle, until so much has filtered; and the solution in the funnel having fallen, the action is repeated until the entire contents of the bottle are filtered, without any attention being required.—The Professional and Amateur Photographer.

RECREATION is the best authority on sport I ever saw. I would not be without it.  
Frank McMullen, Honesdale, Pa.



*In the eye of the public.*

Merit and its due, publicity, means success—but publicity without merit means disaster and failure, for the public cannot be fooled successfully. The

# Ostermoor Patent Elastic Felt Mattress \$ 15.

is a proven success, due to public knowledge of genuine merit. It is better than hair in every possible way—softer, cleaner, purer, and far more elastic; dust-proof, vermin-proof, germ-proof, and so water-proof it will float. These merits are enduring; it never requires remaking, and is practically un-wear-out-able.

Not stuffed like hair, but built of eight airy, interlacing sheets of billowy, downy, everlasting softness, hand-laid and daintily enclosed in tick by hand sewing.

These sheets are called "Felt," and the name "Felt" is trade-marked and copyrighted by Ostermoor & Co.; an "Ostermoor" Mattress, therefore, is the *only* "Felt" Mattress.

If it isn't an "Ostermoor" it's an imitation. Our name and trade-mark label must appear on the end of every genuine "felt" mattress. Be careful! Don't be fooled!

Send for our 96-page illustrated book, "The Test of Time." It's yours for a postal.

**STANDARD SIZES AND PRICES:**

2 feet 6 inches wide, 25 lbs.,	- - -	\$ 8.35
3 feet wide, 30 lbs.,	- - -	10.00
3 feet 6 inches wide, 35 lbs.,	- - -	11.70
4 feet wide, 40 lbs.,	- - -	13.35
4 feet 6 inches wide, 45 lbs.,	- - -	15.00
All 6 feet 3 inches long.		

In two parts 50c. extra. Special sizes, special prices.  
Express charges prepaid to any place.

**THIRTY NIGHTS' FREE TRIAL.**

You can have an Ostermoor Mattress, sleep on it thirty nights, and if it is not better than any other Mattress you have ever used—if it is not all you even HOPED for—return it at our expense and your money will be immediately refunded without question. What more can we do to convince you?

**OSTERMOOR & CO., 114 ELIZABETH ST., NEW YORK.**

Canadian Agency: The Alaska Feather and Down Company, Ltd., Montreal.

# Fisk's Aerating Minnow Pail



The only Minnow Pail in which Minnows can be kept alive indefinitely.

Has an air chamber at the bottom holding 26 cubic inches of condensed air forced in by the Air Pump attached, and by a simple rubber attachment the air is allowed to escape into the water gradually supplying the fish with the oxygen consumed by them. One pumping is sufficient for ten hours.

Height, 1 foot; diameter, 10 inches; weight, 7½ lbs.; water, 2½ gallons; keeps 50 to 150 minnows, according to their size.

**IT KEEPS THEM ALIVE**

Send for circular Mention RECREATION

**J. M. KENYON & CO.**  
214 Twelfth St., Toledo, Ohio, U. S. A.

# S L E E P

IS TIRED NATURE'S  
SWEET RESTORER

After a hard day's tramp, you must have

## A GOOD NIGHT'S REST

in order to fit you for the next day's work.

Better to sleep on a good bed without your dinner, than sip at a banquet and then sleep on the cold, hard, wet ground.

You can get

## A Recreation Camp Mattress

of rubber, with valve for inflating, made by the Pneumatic Mattress Co. and listed at \$18

For 15 Yearly Subscriptions  
to RECREATION

Send for Sample Copies

Address RECREATION, 23 W. 24th Street, New York

Denver, Colo.

The Peters Cartridge Co.,  
Cincinnati, Ohio:

Dear Sirs:—I have been much interested in the controversy between your company and Mr. Shields, editor of RECREATION. Mr. Shields is a personal friend of mine, and I much admire the earnest and disinterested fight which he is making along the lines of game protection. He has many warm friends throughout the land, and it seems to me, as a disinterested party, that you are making a mistake, from a business point of view, in breaking off your relations with him. No honest, fairminded manufacturing concern should object to criticism, if conducted in a fair spirit, or take offense at it, but should rather welcome it. All people are not of the same mind, or taste, even where goods are of equal merit. If it were otherwise, we should have but one cartridge company in the country, and the same of other goods. I am not one who thinks your goods above criticism, as the following will show:

Some years ago I ordered from a dealer several hundred Peters shot gun cartridges, for my own use. I used a portion of them, but the results were entirely unsatisfactory. Not only was I unable to do the customary execution, but the performance of the cartridge was objectionable in other ways. The shell invariably gave way at its junction with the base, sometimes to such an extent that the base was removed by the ejector, leaving the balance of the shell in the chamber of the gun. In not a few instances this portion of the shell was forced up into the barrel of the gun, leaving only the base in the chamber. In nearly every case the cylinder of the shell, after discharge, was found to be considerably mutilated, being sometimes ripped open, and often perforated in many places by particles of unburned powder, or other substances. I was using a high grade Lefever hammerless gun, and the escape of gas into the breech was so great that I decided to forego the use of these cartridges after a portion had been used. I gave away the balance, except 2 boxes, which I still have on hand, to friends of mine who I thought were not very discriminating. I have never made these facts public, but I think you ought not to be too sensitive to a little criticism.

A. Whitehead.

As I have fewer opportunities to smell powder in the fields, a magazine like RECREATION appeals to me more and more. Nothing is quite so interesting as stories dealing with sports requiring skill and endurance such as once enlisted my best efforts. RECREATION has a legitimate field of action; a field that will grow wider each year, and the magazine keeps in advance of the times. May 1903 bring you a full measure of those things men consider desirable.

F. D. Blake, Clay Center, Kan.



Camp Bristol

One enthusiastic sportsman—a constant user and admirer of the

**“BRISTOL” STEEL RODS**

has his occasional *habitat* in the camp above pictured. He writes:—

“I have discarded my split bamboo and my wood rods I formerly ‘swore by,’ and am ‘in love with’ the ‘BRISTOLS’ you sent me. Tell the boys to throw away all nonsensical prejudice, and hasten to form the acquaintance of a ‘Bristol’ Rod—for there’s millions (of fish) in it.”

We will send you our free catalogue if you like—then you can do as you choose.

**The Horton Manufacturing Company**  
No. 73 Horton Street, Bristol, Conn.

# THE LATEST, SAFEST AND BEST CANVAS BOAT



Is what we offer you. A Boat built on modern lines that will prove a pleasure to own and use. Selected materials used throughout, and it comes to you **guaranteed** the best. A handy and safe boat for fishing and shooting. Send 4 cents in stamps for catalogue and reliable testimonials.

Mention RECREATION.

**LIFE SAVING FOLDING CANVAS BOAT CO.**  
Kalamazoo, Mich.



Latest patent and improved Canvas Folding Boat on the Market. Puncture proof. Tempered steel frame. No bolts to remove. Folds most compact of any boat made.

## Mullins' Metal Boats



**"Get There" Duck Boat** in use. Be sure and order one for your Fall shoot. Approved by sportsmen wherever used. Send for catalogue, with prices, etc. Mention RECREATION.

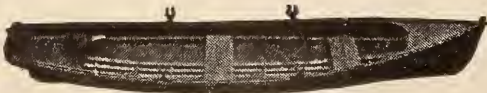

**"PRINCE."** 14 ft., square stern model. Especially adapted for family and livery use.

\$30 crated on cars, Salem.

**W. H. MULLINS**

228 Depot St.

Salem, Ohio

### NOTES.

At the Baltimore, Maryland, shoot, June 2d, 3d and 4th, in which 80 shooters participated, DuPont smokeless won everything, as follows:

Open Events—1st general average, L. S. German; 2d general average, J. M. Hawkins; 3d general average, L. J. Squier.

Amateur Events—1st general average, H. D. Jackson; 2d general average, W. L. Henderson.

Baltimore Handicap won by W. L. Henderson; score, 48x50, 19 yards.

County Amateur Championship of Maryland won by H. D. Jackson; score, 100 straight.

Three man team race won by Cecil County team; score, Cole, 49; Miller, 46; Jackson, 46; total, 141x150.

I have sent you 15 subscriptions to RECREATION, for which please send me as premium a 12 gauge Davenport ejector shot gun. I have not spent 5 minutes in getting up this club. RECREATION speaks for itself. No true sportsman can afford to be without it.

Alvord Van Gorder, Ansonia, Pa.

Mr. U. B. Atchison, Box 308, Melrose, Minn., would like to hear from Mr. Charles O. Bartley, formerly of Schroyer, Kansas.



# FAY & BOWEN Motors & Launches

Operated by  
Gasoline Vapor  
Motors 1½ to 25 H.P.

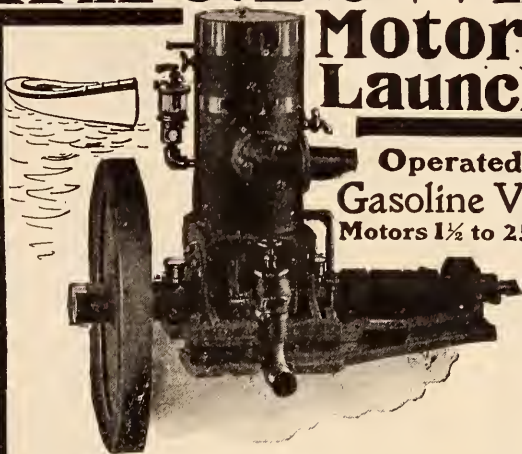

**T**HE Fay & Bowen Marine Motor is a revelation to those who have used others. Reliable, safe, durable and easy to operate. Remarkable speed control. Best of all, it starts when you start it. No handle or crank is used. Our patent igniter is absolutely unique and always instant and positive in action. It is really the only perfect and satisfactory igniter.

Motors complete from 1½ to 25 H. P. ready for installation. We also build handsome launches with motors installed and ready to run

*Send for Catalogue.*

**Fay & Bowen,**

28 Mill Street,

Auburn, N. Y.

"Lillian, there were 3 pieces of cake in the pantry, and now there is only one. How did that happen?"

"It was so dark in there I didn't see the other piece."—Exchange.

RECREATION is the finest magazine for sportsmen I have ever seen. It fills the bill in every way.

H. W. Hamlyn, Melrose, Fla.

Thanks for the Bristol steel fishing rod. It is a gem.

E. W. Jaques, Little Genesee, N. Y.

## MARINE GAS ENGINES

Experts for years have ranked our engines with the highest grade, and it is now being copied by other builders. We always endeavor to be on top and for 1903 offer an engine built from brand new patterns, with **NEW** and **ORIGINAL** features—just what other engines will have five years hence. If you want to be in the lead send for catalog fully describing all parts, and then buy a "Rochester".

**ROCHESTER GAS ENGINE CO.**

700 Driving Park Ave.

Rochester, N. Y., U. S. A.



11-foot Special

**Folding Canvas Boats** were not satisfactory until the **King** was produced. **It's a revelation** in boat construction. Nothing like it ever made. **Nonsinkable. Can't tip over. Puncture-proof.** Wear longer than a wooden boat. **No repairs.** No cost for storage. **Always ready.** Folds into a small neat package,—**carry by hand.** Used by the U. S. Navy. They are simply wonderful. A thoroughly patented article. Beware of imitation. Made only by ourselves.

A catalogue of 70 engravings and 350 testimonials sent on receipt of 6 cents. Mention RECREATION.

**King Folding Canvas Boat Co.**  
Kalamazoo, Mich., U. S. A.

I must say that RECREATION has power to stir the blood in my veins as few similar magazines do. The photo reproductions are sure to be a drawing card for you now and in the future.

Rev. P. B. Peabody, Hallock, Minn.

A genial old verse-writing Col.  
Wrote poems about seasons vol.,  
But although he sent down  
All his verses to town,  
He couldn't sell one to a jol.

## THE HILDEBRANDT SPINNER



For Fly Fishermen. A spinner which spins, and also catches fish. Strictly hand-made and of the best material. Noswivel required. Made with all kinds of Feather and

Buck-tail flies. For sale by dealers. Sent on receipt of 25c.

**J. J. HILDEBRANDT, Logansport, Ind.**



U. S. Government who prefer our boats. Received medal and award at Chicago World's Fair. If you investigate we will get your order.

Send for catalogue of our full line of **Folding Canvas Boats and Canoes**, which have been adopted by Governments of United States, Canada and England. Just filled an order for **medal and award at Chicago World's Fair.** Mention RECREATION.

**Acme Folding Boat Company, Miamisburg, O.**

Are You an  
Amateur  
Photographer ?

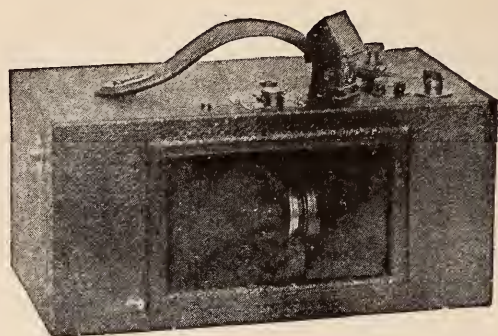

If so would you like a Camera  
that will photograph

A whole range of mountains  
A whole sweep of river  
A whole army  
A whole fleet of ships  
A whole city

Or any other vast stretch of scenery or moving  
objects ? THE SWING LENS DOES IT

The **Al Vista**

Is the thing. It lists at \$30

One of the greatest inventions of the age.  
Given as a premium for 12 subscriptions.

For particulars Address

**RECREATION**

23 West 24th Street

NEW YORK CITY



## SPORTSMEN, LISTEN A MOMENT

Did you ever stop to think you are losing the permanent value of your field sports by not saving your fine trophies?

Learn by Mail to mount Birds, Animals, Heads, Fishes, etc. We teach Taxidermy exclusively—nothing else. A school by sportsmen for sportsmen. A complete course of 15 lessons that positively teach you to do the work. Have you had our literature? We want to send it to you free. Write us to-day. A postal brings it. Mention RECREATION.

### The Northwestern School of Taxidermy

411 A Bee Bldg.

The only School of Taxidermy in the World

Omaha, Nebr.

When securing subscribers for RECREATION, it is often amusing to watch some sportsman when he gets the first sample copy in his hands. Mention \$1 a year, and see how his eyes grow larger with every beautiful page turned. When they have reached the limit in size, out comes his \$1 and he is a friend and admirer of RECREATION forever.

John Slovinsky, Pittsburg, Pa.

You are certainly to be congratulated on the unusual success of your magazine in a field which was, apparently, covered. RECREATION has proved the real thing.

C. A. Cramer, Fort Ann, N. Y.

## High-Bred Pointers

I have six high-bred, thoroughly well broken black and white pointers for sale.

They are two years old and eligible to registration—King of Kent strain, sired by Hal Pointer.

They are staunch on point, tender retrievers, wide rangers, good bird finders, strong and healthy, of good disposition, and steady under the gun. Every dog guaranteed.

Photograph and copy of pedigree furnished on receipt of 10c. to cover postage.

## Dr. W. A. Dorland

Grand Rapids, Mich.

## For Want of Cash Must Sell Quick

10 pair of Wood Ducks, 15 pair of Blue Wing Teal, 10 pair of Green Wing Teal, 14 pair of Garganey Teal, 10 pair of Pintails, 5 pair of Shovellers, 10 pair Gadwalls, 20 pair Wild Mallards, 20 pair of Gray and White Calls, 5 pair of Black Ducks, Trio of Brant, 3 pair white Swans (European) \$30; 50 Mongolian, Ringneck, Chinese Hybrid, Silver and Golden Pheasants; 1,000 pair of Imported Homers for Squab breeding; 50 Imported Runts, 20 pairs imported Peafowls. Book on Pheasant keeping and Squab raising. Send 2 stamps for my booklet that tells "HOW TO MAKE MONEY" breeding Squabs, Pheasants and Quail. I want to buy all kinds of Live Animals, Wild Ducks, etc.

GENEI DeGUARDINER, Natick, Mass.

## Squab Book Free



Squabs are raised in 1 month, bring big prices. Eager market. Astonishing profits. Easy for women and invalids. Use your spare time profitably. Small space and capital. Here is something worth looking into. Facts given in our FREE BOOK, "How to make money with Squabs." PLYMOUTH ROCK

SQUAB CO., 11 Friend St., Boston, Mass.

I was something like a market hunter myself, but you and your magazine cured me and made a sportsman of me, for which I thank you very much.

B. Knispel, Ebenezer P. O., Wis.

**FREE!** Complete instructions for preserving and mounting Birds, Game Heads, Fishes, etc., etc., and also how to dress Skins with hair on for rugs and robes.

Hunters, Trappers, Anglers, Collectors and all others interested in saving trophies for decoration or sale, send stamp for free instruction. Mention RECREATION.

MORRIS GIBBS, M. D.

Level Street

Kalamazoo, Mich.

**Taxidermists' Glass Eyes for Stuffed Birds and Animals**  
Oologists' and Entomologists' Supplies **Materials**

Send 5c. in stamps for catalogue

**FRED. KAEMPFER, 88 STATE ST., Chicago, Ill.**

Taxidermy work done in all its branches  
Mention RECREATION

## FOR SALE

The largest collection of Game Heads, Horns, and Antlers in America. A total of TWO HUNDRED AND FIFTY SPECIMENS, including many record heads and exceptional freaks and rarities. Full information and catalogue on application.

A. E. COLBURN

Bond Building,

Washington, D. C.

## FLORIDA BIRDS.

I have on hand a fair assortment of our Native Bird Skins, suitable for schools, museums or private collections.

During the season of 1903 I will collect any birds or mammals to order.

Finest mounted work a specialty.

**R. D. HOYT, Taxidermist,**  
SEVEN OAKS, FLA.

## Cavies or Guinea Pigs

Peruvian, Abyssinian or English Long or Short Haired. All colors. 400 to select from.

T. RACKHAM,

East Orange, New Jersey.



**FINE MOUNTED GAME HEADS, BIRDS, ETC.,** for sale at unheard-of prices. Send 10 cents for photos.

JOHN CLAYTON, Taxidermist, Lincoln, Maine

Date, \_\_\_\_\_ 190

G. O. SHIELDS,

Editor and Manager of RECREATION, 23 West 24th St. New York.  
Herewith find \$1.00 for which please send me RECREATION one year  
beginning with \_\_\_\_\_ number,

Name, \_\_\_\_\_

Remit by P. O. or Express Money Order, or New York Draft.

DETACH THIS, FILL OUT, AND SEND IN

RELICS OF A DISAPPEARING RACE

# Buffalo Skulls

WITH POLISHED OR  
UNPOLISHED HORNS

Also polished or unpolished horns in pairs or single. Polished horns tipped with incandescent electric lights; polished hunting horns; mirrors hung in polished horns, etc. These are decided novelties and are in great demand for sportsmen's dens, offices, club-rooms, halls, etc. Send for illustrated catalog. Mention RECREATION.

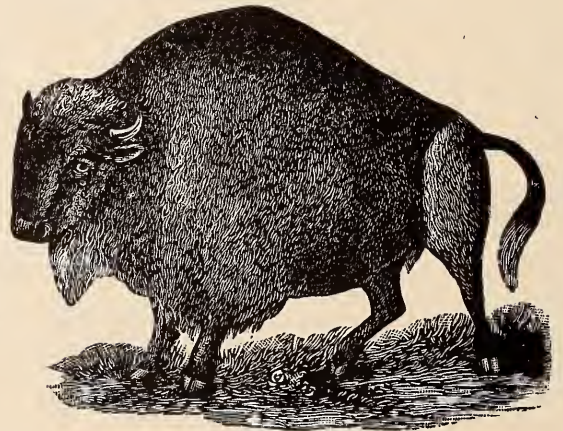

E. W. STILES

141 Washington St. Hartford, Conn.

You gave the game hogs some good whacks in the December number; especially the maker of the electric fishing rod. Keep it up and perhaps they will see their mistake some day.

H. E. Spaulding, Dresden Centre, N. Y.

I have been a long time a reader of your magazine, and think highly of it. I have also the highest regard for you personally for the stand you take against the slaughter of game.

Chas. F. Emmel, Vandalia, Ill.

## APPLICATION FOR MEMBERSHIP IN THE L.A.S.

ARTHUR F. RICE, Secretary L.A.S., 23 W. 24th St., New York.

DEAR SIR: Enclosed \$1 for membership fee for one year.

I certify that I am eligible to membership in the L. A. S. under the provisions of the constitution, and refer to 2 League members (or to 3 other reputable citizens) named hereon.

Name.....

Street or P.O. Box.....

City or Town.....

References

Detach this, fill out and send in.

## SOME GOOD GUIDES.

Following are names and addresses of guides who have been recommended to me, by men who have employed them; together with data as to the species of game and fish which these guides undertake to find for sportsmen.

If anyone who may employ one of these guides should find him incompetent or unsatisfactory, I will be grateful if he will report the fact to me.

## ALASKA.

Edwin Edclmann, Kenai, Cook's Inlet, moose, bear, caribou, mountain sheep, ducks, grouse and trout.

## FLORIDA.

Carson Bros., Frostproof, bear, deer, turkeys, quail, snipe.

C. H. Stokes, Mohawk, deer, alligators, turkey, quail, and snipe.

## IDAHO.

John Ching, Kilgore, elk, bear, deer, antelope, mountain sheep, trout and grouse.

Chas. Petty's, Kilgore, ditto.

## MAINE.

H. R. Horton, Flagstaff, deer, bear, moose, caribou, fox, grouse and trout.

W. C. Holt, Hanover, moose, caribou, deer, grouse and trout.

## MONTANA.

A. R. Hague, Fridley, elk, deer, mountain sheep, bear, grouse and trout.

Chas. Marble, Chestnut, ditto.

## NEW YORK.

Le Roy Still, Bayport, Long Island, ducks, quails, rabbits and grouse.

## WASHINGTON.

Munro Wyckoff, Port Townsend, deer, bear and grouse.

## WYOMING.

S. N. Leek, Jackson, elk, bear, deer, mountain sheep, antelope, grouse and trout.

James L. McLaughlin, Valley, elk, bear, deer, mountain sheep, antelope, grouse and trout.

## CANADA.

Wm. S. Andrews, Lillooet, B. C., deer, bear, mountain sheep, goats, grouse and trout.

B. Norrad, Boiestown, N. B., moose, caribou, grouse and trout.

Carl Bersing, Newcastle, N. B., moose, caribou, deer, bear and grouse.

## NEWFOUNDLAND.

John C. LeMoine, Birchy Cove, Bay of Islands, caribou salmon and trout.

**Do you enjoy big game hunting?  
Or Trout Fishing?  
Or Mountain Climbing?**  
**If so, write us and we can accommodate you.**

We keep 65 head of horses. We employ a full corps of experienced guides, packers, and cooks.

We have a complete outfit of riding saddles, pack saddles, tents, stoves, cooking utensils, tableware, and everything necessary for touring and camping in the Mountains.

We live at Banff. The Eastern gateway of the Canadian Rockies.

And can send you anywhere you may wish to go from this point

*North, East, South or West.*

**Address: BREWSTER BROS.  
Banff, Alberta, Canada.**

IN THE ADIRONDACKS

## Indian Lake House

Mountain View, N. Y.

C. C. Morgan, Prop.

ALL THE YEAR

All passenger trains on A. & St. L. R. R. will be met by boat and bus. Passengers conveyed directly to the house.

Rates. \$2 per Day.

Special Rates to Parties

Best DEER HUNTING and TROUT FISHING to be found in the Adirondacks

**Free**—To each person sending me \$1 (post-office money order) for one year's subscription to RECREATION, I will send choice of a Braided Leather Dog Whip, with a steel snap on end, or a Polished Steel Dog Chain, with swivels, snaps, etc., or one dozen assorted Trout Flies, silk bodies, good ones, or a Pocket Compass, one inch dial, open face, watch shape, with ring handle and bevel crystal. Also a special offer limited to the months of June, July, August and September of a nickel plated multiplying 40 yard raised pillar reel, balance handle with click, drag and free running for two subscriptions. For four subscriptions a genuine 6 strip Split Bamboo or Fly Rod, 4 pieces with grips, silk whipped, nickel plated mountings, solid metal reel seat, length about 9½ feet.

Edward S. Adams,

Box 536, Manchester, N. H.

### Do You Want a Drinking Cup Free?

Send me \$1 for a new subscription to RECREATION and I will send you a fine nickel-plated folding drinking cup. For 10 cents extra will send by registered mail. Mrs. Thomas H. Walker, 295 Merrimac Street, Manchester, N. H.

## FRESH RICE SEED FOR SALE

Chas. Gilchrist, Port Hope, Ontario, Can.

## BEST FISHING

AND

## FINE HUNTING

Earliest and latest Moosehead lake fishing is had here; also plenty of big game. House has been entirely refurnished; rooms have hot and cold water and baths. Grounds nicely graded, tennis court, croquet grounds and many fine woods roads laid out. Fishermen can avoid expense of guide by coming here, although we furnish guides, boats and canoes when desired. Several camps in our "string," all snug and attractive. Rates \$2.00 to \$2.50 per day. Descriptive Booklet sent free.

## At OUTLET HOUSE

(Formerly Moosehead House), MOOSEHEAD, ME. 11 miles from Greenville by C. T. R. R. or by Steamer.

**CHARLES E. WILSON - Propr.**

New steamboat just bought to accommodate our guests.

# TO AMATEUR PHOTOGRAPHERS

Here is a Chance  
to Get a  
FINE CAMERA EASILY

A 4x5 Tourist Hawk-eye film camera listing at \$8, for 5 yearly subscriptions to RECREATION. A No. 3 folding Weno Hawk-eye film camera, listed at \$15, for 10 yearly subscriptions to RECREATION.

These are both neat, compact, well made and handsomely finished cameras, capable of doing high-class work.

*Sample copies for use in canvassing  
furnished on request.*

Address RECREATION

23 West 24th St.

NEW YORK CITY

## Newhouse Traps

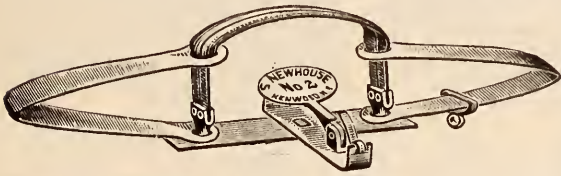

THE STANDARD FOR OVER FIFTY YEARS

Used by all professional hunters and trappers, who find that

**The Best Trap is the Cheapest**

Complete illustrated catalogue on application.

ONEIDA COMMUNITY, LTD., Kenwood, N. Y.

Practical Common Sense  
in 6 Sizes.

### CAMP STOVE

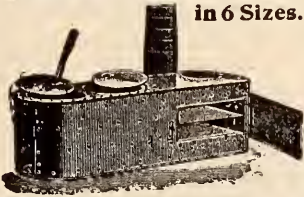

Either with or without oven. The lightest, strongest, most compact, practical stove made. Cast combination sheet steel top, smooth outside, heavy lining in fire

box and around oven, holds its shape, telescopic pipe carried inside the stove. Burns larger wood and keeps fire longer than any other. Used by over 9,000 campers and only one stove returned.

For catalogue giving full particulars, mention RECREATION and address,

**D. W. CREE, Manufacturer, Griggsville, Ill.**



### INDIAN CURIOS

WHOLESALE & RETAIL  
CURIO DEALERS'  
SUPPLY DEPOT.

Bead Work, Baskets, Elk Teeth, Mexican Goods, Fossils, Minerals, Arrow-Heads, Pottery, Alaska Ivories, Shells, Agates, Photos, Great stock, Big Cata. 5c., stamps, Mention RECREATION. If a dealer, say so.

**L. W. STILWELL**

DEADWOOD . . . . . SO. DAKOTA



# 96%

The general average made by

**Mr. Fred Gilbert in 1902**

shows that

## DUPONT SMOKELESS

is Absolutely Uniform

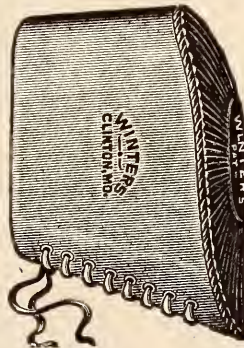

## THE 1902 Model

LEATHER-COVERED Pneumatic Recoil Pad is now perfect. No pump, no valve, no recoil, no flinch, no headache, no bruised shoulders, no money if not satisfactory and returned at once. PRICE \$2.

**J. R. WINTERS  
Clinton, Mo.**

### KOENIG'S SHELL EXTRACTOR.



Every shooter should have one—carry it in a vest pocket. Fits any gauge shell. Koenig's Gun Catalogue, Free.

10 Cts. Postpaid.

**E. G. KOENIG, NEW JERSEY'S LARGEST GUN HOUSE**  
SOUTH BROAD ST., NEWARK, N. J.

## BRADLEY'S ANTI-RUST ROPES!!

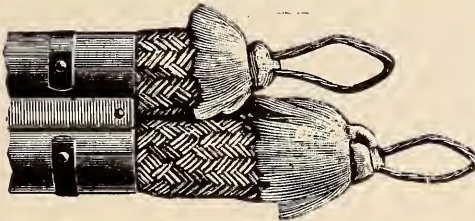

For SHOT GUNS, RIFLES and REVOLVERS. They cannot rust or pit if these ropes are used. No more worrying to keep your fire arms in perfect condition. Sent postpaid, \$1 per set for Shot Guns; 50c. for Rifles; 25c. for Revolvers. Give gauge and length of barrel. Send for circular giving full particulars.

### BRADLEY'S SHOT GUN SIGHT

Makes wing shooting easy and certain. Scores greatly increased at trap and in field. Price, post-paid, 50 cents. Send for circular.

Address **C. L. BRADLEY, CLARKSVILLE, TENNESSEE.**  
Mention RECREATION.

# WANTED

Every owner of a shot gun to learn all about our handy little Target Trap.

*A Card Brings the Information*

Mention RECREATION.

**THE MITCHELL MFG. CO., London, Ohio**

## WHY RECREATION PULLS.

Through the kindness of a friend I have been reading a few numbers of RECREATION, with which I am delighted. Its pages of reading and pictures are good "meat," fit food for kings. Enclosed please find \$1, for which please send the magazine one year, beginning with the January number.

Dr. H. F. Hicks, Joliet, Ills.

Not the least interesting thing about RECREATION is its advertising matter. About the first thing I came across when I opened it was the ad of the Eastman Co.'s folding kodak. It was just what I wanted and had looked for for some time. I must thank RECREATION for bringing it to my notice.

Dr. D. B. Wylie, Milwaukee, Wis.

I am greatly pleased with RECREATION, and heartily indorse your items in regard to the game hogs. We have a few in this section. It seems they must have a big story to tell regardless of the damage to game. If they read RECREATION a year or so, they will reform.

R. J. Tolford, Sandcreek, Mich.

We have all been readers of RECREATION a long time, but we grew tired of running races to our newsdealer to see who should have the magazine first. I just made up this club to stop the racing, as I am not a good runner.

R. Bolon, Weiser, Idaho.

Enclosed find \$1 for renewal of my subscription to your valued magazine. I like the plain, manly, sportsmanlike tone of it. It has done more to advance the interests of true sportsmen and show up duffers than any other publication.

C. E. Crook, Sydney, C. B.

Your magazine strikes me square. The position you take on the subject of game slaughter alone ought to recommend RECREATION to every honest sportsman, and be the means of doing lots of good in the protection of our game.

Thos. K. Norris, Cortland, N. Y.

I want to congratulate you on the success of your magazine. Your efforts for the preservation of the game from market hunters and game hogs deserve the support of every sportsman in the land.

Jas. F. Fitzgerald, Lawrence, Kan.

RECREATION deserves 1,000,000 subscribers for the good work it is doing for game protection, as well, also, for its excellent

character as a sportsman's journal. It leads them all.

Piatt Carnahan, Carthage, Mo.

My son, Burt L. Warriner, thinks he can neither sleep nor enjoy good health unless he can read RECREATION. He moreover feels that in order to fully enjoy these things, the copy he reads should be his own.

J. O. Warriner, Tomah, Wis.

Enclosed find \$1 to pay for RECREATION for one year. Could not do without it. It is the best magazine published in the sportsmen's line. It improves with every issue. I wish you continued success.

W. O. Bunnell, M. D., Meshoppen, Pa.

I am in the publishing business myself, and have been a sporting editor for years. The manner in which you get out RECREATION is something to be proud of.

Chas. L. Rice, New York City.

I am pleased with RECREATION and the way you go for fish and game hogs! That's all right, old man, give them fits; we're with you.

H. B. Chapin, Woodruff, Wis.

Don't ever drop my name from your mailing list unless you have notice of my death. Even if you do so then, my wife may have something to say.

H. M. Norton, Corry, Pa.

My ad. in RECREATION gave returns beyond all expectations. Brought correspondence from Philadelphia, Boston, Buffalo, New York and all around.

Geo. Cornell, Mt. Upton, N. Y.

Of course I want RECREATION. It is on the right track. Hits from the shoulder, and hits hard in the right place.

A. L. Foote, Newark, N. Y.

RECREATION is the best sportsmen's journal ever printed. So all say who have examined it.

S. L. Doolittle, Ingersoll, Ont.

RECREATION is the best journal on hunting and fishing I ever read. Would not think of getting along without it.

A. G. McCurry, Stoneham, Pa.

Your magazine is getting better all the time. I take it straight, from cover to cover.

F. H. Huggins, Portland, Ore.

RECREATION gets better each month. All your subscribers here speak of it as being the best magazine they ever read.

W. W. Worthen, Mandan, N. D.



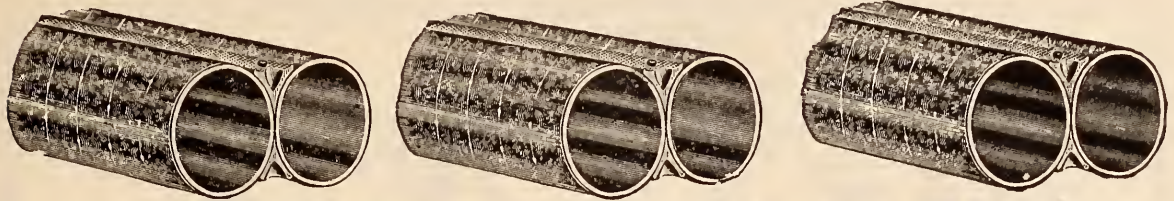

# ITHACA GUNS

TAPER  
GRACEFULLY  
TO THE MUZZLE

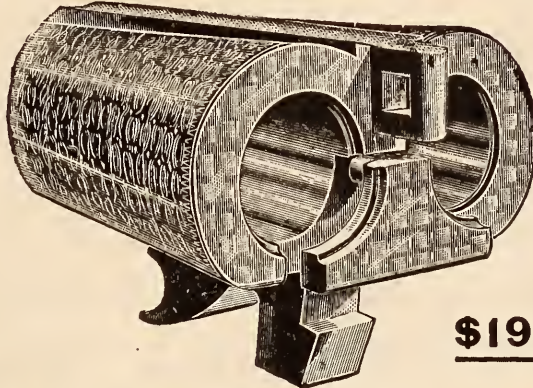

HAVE  
DOUBLE-THICK  
NITRO BREECH

CROSS  
BOLTED

16 GRADES

\$19.50 TO \$300

ITHACA GUN CO., ITHACA, NEW YORK

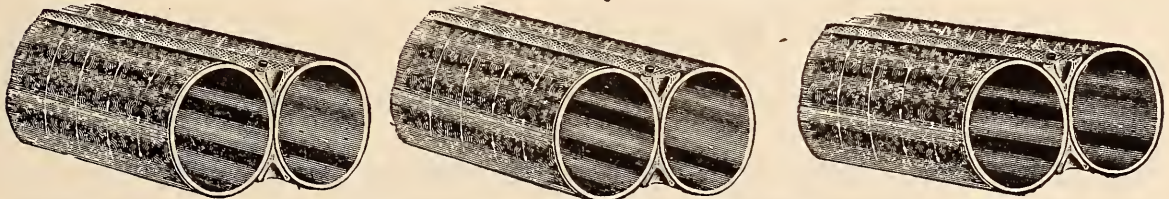

I received the Malcolm telescope you sent me for a premium, and it is as fine a piece of work as anyone could wish for a hunting rifle. I am well pleased with it.  
George R. Brown, Pittsfield, Mass.

No other magazine is read by my family with as much zest and pleasure as RECREATION. You are doing a good work. Success to the L. A. S.  
R. Thomas, Grant's Pass, Ore.

## ANTI-RUST WICK PLUGS AT REDUCED PRICES

Arms fitted with Wick Plugs can not Pit or Rust

REDUCED PRICES

Shot Gun, per pair, \$1.00 postpaid

Shot Gun, per Plug, .50 postpaid

Rifles, per Plug, .50 postpaid

*Give gauge and length of barrel*

**HEMM & WOODWARD, Sidney, O.**

Write for Circulars. Mention RECREATION

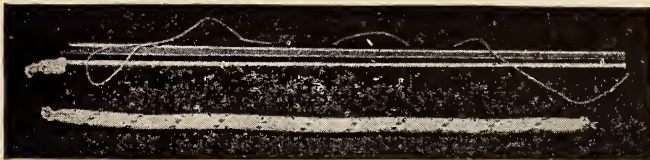

### THE DAVENPORT Hammerless No. 2

With Full Length Matted Top Rib



OUR LATEST

Without a PEER for the  
Trap.

Send for latest  
edition of  
our catalogue  
—just out.

Mention  
Recreation

Our "Brownie" Rifle is in great demand amongst the "boys"—.42 caliber only  
The W. H. Davenport Fire Arms Co., Norwich, Conn.

# GUNS

OUR new 250 page catalogue of Guns, Fishing Tackle and Sporting Goods is now ready. If interested in any of these goods, send 20 cents and we will mail you one. If interested only in Fire Arms send 5 cents for Specialty Catalogue describing

**Charles Daly Guns**

**T. W. Stake Guns**

**Walsrode & Wolf Powder**

**Mauser Rifles**

Mention RECREATION.

**Luger Pistols**

**Schoverling, Daly & Gales**  
302-304 Broadway  
NEW YORK



## "Collan-Oil"

preserves leather and renders shoes and harness positively

### WATERPROOF

Used by the U. S. the Army and Navy, and National Guard.

Send 25c. for trial can.

AGENTS WANTED

Write for terms and circulars

**J. R. BUCKELEW**

Dept. A. 111 Chambers St., N. Y.

**The Best Offer Yet.**—To any person who will subscribe to RECREATION for one year through me I will send free a small water color landscape, hand painted, suitable for framing; or a hand painted silk bookmark. For two subscriptions I will send a fine Mexican opal scarf pin worth ordinarily from \$1 to \$1.50.

Don M. Harris, 308 Crawford Road,  
Cleveland, Ohio.

Quails and rabbits are scarce here. We have a few ruffed grouse in places, and some ducks, but mostly out of season, spring shooting being forbidden.

B. W. Dicer, Albion, Mich.

## THE BAKER

THE GUN  
THAT'S SAFE



SO DURABLE TO  
IT LASTS A  
LIFETIME

If you want to be right up in the front rank of style and efficiency shoot one of our **Special Paragons** with *Whitworth* or *Krupp fluid steel barrels*. We have other patterns also that would please you. Our "Quarterly" tells about them and other matters that would interest you. We will send it to you *free a year* if you want it.

**BAKER GUN & FORGING CO., 42 Liberty Street, Batavia, N. Y.**

H. &amp; R.

# "Bicycle Hammerless" Revolver

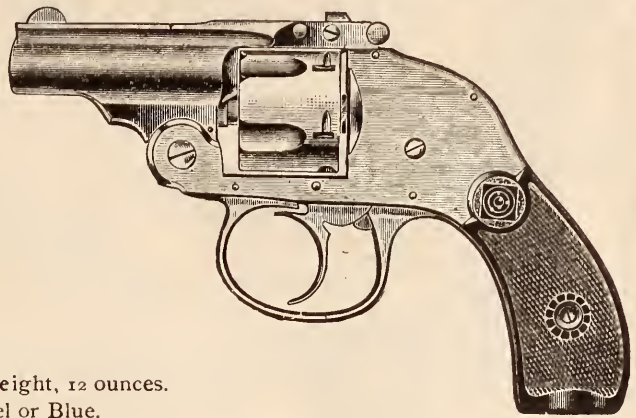

### Description

32 Caliber, 5 shot. 2 Inch Barrel. Weight, 12 ounces.  
C. F., S & W. Cartridge. Finish, Nickel or Blue.

**IMPOSSIBLE TO CATCH** on the pocket and discharge accidentally. **ABSOLUTELY SAFE.** Although designed for cyclists, this revolver is equally adapted to all cases where a small, light weight, effective and handy pocket weapon is desired. It has small frame and automatic ejector. Sold direct where dealers will not supply.

## HARRINGTON & RICHARDSON ARMS CO.

Makers of H. & R. SINGLE GUNS

Catalog for Postal  
Dept. R.

**WORCESTER, MASS.**

I take great pleasure in renewing my subscription to RECREATION. It is a really fine journal, easily the best of its kind I have seen. Of its many excellent features not the least commendable is your sturdy condemnation of the game hog. This should deserve the recognition of all good sportsmen.

F. N. Allen, Southampton, Ont.

RECREATION is the best magazine I ever had in my hands.

John F. Stabler, Ann Arbor, Mich.

Peters cartridges do not sell well here. There are too many RECREATION readers. They read of the trouble sportsmen have with these goods, and decline to buy them. The dealer has some Peters shells he has had on hand 3 years. Once in a while he sells a box to a farmer.

J. F. Wiggins, Tunkhannock, Pa.

I am agreeably surprised with the quality of your premiums, as they are invariably of better grade than one has a right to expect.

H. M. Onyett, Decatur, Ill.

## THE PARKER AUTOMATIC EJECTOR



The Latest attachment to  
The "OLD  
RELIABLE"

New York Salesroom, Send for Catalogue. PARKER BROS.,  
32 WARREN ST. Mention RECREATION. Meriden, Conn.



Price  
\$1.50 each.

MENTION GAUGE WANTED.

THE PHIL. B. BEKEART CO., of San Francisco, Cal., Agents for Pacific Coast.

When you write please mention Recreation.

## THE IDEAL "STRAIGHT LINE" RE & DE CAPPER

is the **only one** that will de-cap and re-cap properly, **all** Shot Gun Shells with a central fire hole, Brass or Paper, Domestic or Foreign make, whatever the inside shape may be, **high or low base.**

It will seat any and all sizes and shapes of primers, **straight** in the pocket of the shell, **positively all the same depth, without concaving**

**the head, or disturbing the fulminate** which causes misfires. Send us six cents in stamps for **HAND BOOK No. 15**, giving full information of **New Goods** and much new matter of interest to shooters. Address,

**IDEAL MANUF'G CO., 12 U St., New Haven, Conn., U. S. A.**

### AN ALASKA SHEEP.

My camp was at the big spring on the Kenekott, in the Chitina country, Alaska. The low, rolling hills were covered with scattering spruce trees and luxuriant bunch grass, and rugged peaks formed the background. The day afforded an opportunity for admiration of the sublime view.

Two hundred yards away lay the great Kenekott glacier, weird and desolate, with its cold, suggestive effrontery, its deep blue crevasses, a river of ice extending from the gigantic Wrangel, mother of a family of glaciers, several miles below, where the Kenekott river boils from beneath it in such a manner as to derive the name of the Pot Hole.

My attention was attracted to the quacking of a duck in the spring, a pool about 60 feet in width. As it was a change from ptarmigan and spruce hen, I used my automatic pistol in transferring the duck from pool to camp pot.

Presently I heard the jingling of a bell, and soon my lonely camp was surrounded with pack horses and men. Some of the packers unpacked the tired animals, while others built fires and cooked. They were mine inspectors, prospectors, packers and an Indian. I asked Arizona Jack if the great Bonanza mine was near. He slapped me on the shoulder and pointing across the glacier to lime-capped mountains said,

"There she are, not 10 miles from yer, just across this ice, and by the holy pokies and the eternal Christendom she has not moved an inch since I first found her, 2 years ago."

Mr. Amey, long, lank and good natured, motioned me to one side and said,

"You know you missed that bear, in '99, when he was right in camp and we were out of meat?"

"Yes, and I suppose you intend to tell me of it whenever we meet."

"Well, I shall never forgive you for it."

"I don't expect it."

"Notwithstanding you missed the bear, you can get a sheep at the head of Lakanaw river. Do you understand?"

They were soon away and I resolved to get a bighorn. Later, I had the chance, 50 miles from my camp, at the head of the Lakanaw. I ascended a peak, 2,000 feet above my camp. While resting my eyes from the distant view they chanced to focus on a bighorn standing on a narrow shelf on the opposite side of a deep gorge and not more than 75 yards away. It was useless to shoot him there, as he would roll over a precipice. He was standing still, with his large, curving horns outlined against a crag, while my pistol rested on a rock and I waited for him to walk a few yards farther out on the ridge. Presently a small young sheep rounded a sharp corner and walked up close to the old ram, which caused him to move out on the ridge. I changed my mind and resolved to procure the younger of the 2. The old fellow moved out of sight. Fearing the other one would not stop, I fired too hurriedly and broke his back. He fell, rolled over and over, down to the ledge where he had been standing, while I held my breath in fear that he would go on over the bluff. That night lonely owl hoots that emanated from the dark recesses of the spruce pines, and the tinkling of the horse bell were my only companions; but by the bright light of the campfire I feasted on roast mutton.

One hundred and fifty miles of swampy trail, dry birch ridges, swimming of horses, storm and sunshine, took me to Valdez. The old steamer Excelsior whistled for all on board, and a tall gentleman with a cynical expression requested a private interview. He said,

"Guess we'd better have a settlement."

"Very well, Mr. Amey, present your bill."

He took out his pencil, and, scratching on the wharf railing, said,

"It would facilitate matters if you would give an account of the number of sheep you killed on the Lakanaw."

I handed him a cigar, and he remarked that the old bear account could be carried forward.

Addison Powell, Valdez, Alaska.

ONE OF THE 9  
**“SYRACUSE”**  
 Built for Business.



COPYRIGHTED 1903

SYRACUSE ARMS CO.

This picture shows the result of a  
**SINGLE SHOT** from a **SYRACUSE**  
**16 GAUGE**

THREES OF THIS KIND ARE HARD TO BEAT

Write for a  
 Syracuse  
**CAT.**



**SYRACUSE**  
**ARMS CO.**

**SYRACUSE, N. Y.**

Mention RECREATION.

# FIRE SALE

500 Guns At Reduced Prices

GREAT

## Bargains in Fine Guns

By a fire in our Warerooms on June 9th a part of our stock of Fine Guns and Sportsmen's Goods was partially damaged by water, and we shall close them out at greatly reduced prices to make quick sale.

W. C. Scott & Sons, Premier and other grades—Greener, Langs, Parkers, Remington, Ithaca, and all the leading makes.

Also other articles in Sportsmen's Goods, Athletic Goods, Bicycles, Cutlery, etc.

Send two stamps for List of Guns, showing sizes, etc.

The Chance of the Year

### WILLIAM READ & SONS

107 Washington St., Boston, Mass.

ESTABLISHED 1826

## CEDAROLEUM!

The new Rust Repeller, Lubricator and Cleaner, with injecting tube. Made of the purest chemicals. Every sportsman needs it. Handy to carry in your pocket.

### IT WILL CLEAN

your barrel after using smokeless or black powder

### IT WILL KEEP

your gun in good condition for better work

### IT WILL LUBRICATE

the action of your firearm. Its peculiar quality makes it one of the finest of lubricants.

PRICE, 15 CENTS

## CEDAROLEUM CO.

Perkinsville, Vermont

When trapping last season I used the No. 2 stub spring trap. I like the stub spring, because it can be set in holes and trails, there being no outside springs in the way. Another thing I like about the No. 2 is that the jaws are higher and there is less chance of foot or leg amputation. For skunks, muskrats and minks most trappers use the No. 1½ trap, but I think if larger traps were used there would be fewer 3-legged animals around. I have, time and again, caught muskrats with only 2 or 3 legs. A. N. Holmes, Greenland, N. H.

I take 11 other periodicals, and none of them is so welcome as RECREATION.

W. B. Smith, Maxwell, Cal.

We make a specialty of Featherweights  
and Trap Guns with our new  
SINGLE TRIGGER



Send stamp  
for 1903 Catalogue  
Mention RECREATION

### D. M. LEFEVER SONS & CO.,

Manufacturers of the "NEW LEFEVER"

Not connected with Lefever Arms Co.

SYRACUSE, N. Y.

Guaranteed  
Perfect

Our New  
Perfect  
Gun Cleaner  
By Mail,  
30 Cents



## Wholesome Luncheons

When you are at loss to know what to serve for luncheon—when you crave something both appetizing and satisfying, try

### **Libby's** (Natural Flavor) **Food Products**

Among the many Libby delicacies are Boneless Chicken, Melrose Paté, Veal Loaf, Peerless Wafer-Sliced Dried Beef, Potted Ham and Corned Beef Hash—wholesome foods that are as dainty as they are good—as substantial as they are appetizing. Every Libby Product is as wholesome as though made in your own kitchen, under your personal direction.

The Booklet, "How to Make Good Things to Eat," sent free.  
Libby's Big Atlas of the World, for five 2 cent stamps.

**Libby, McNeill & Libby**

**Chicago**

“BEGINS RIGHT, ENDS RIGHT, IS RIGHT IN THE MIDDLE.”—NEW YORK CENTRAL.

# SAVAGE



## The SAVAGE

25-35, 32-40 and 38-55 calibers are some sizes recently added to the famous 303 and 30-30 Model 1899 Hammerless Repeater. These loads are considered the

standard for accuracy and will probably never be excelled for hunting and target purposes. Savage Rifles are fitted with “Special Smokeless Steel” barrels, and with a breeching mechanism *originally* constructed to withstand the enormous pressures developed by modern smokeless powder. This gives confidence to “the man behind the gun.” *Catalogue G with full particulars mailed on request.*

SAVAGE ARMS COMPANY, UTICA, N. Y., U. S. A.

O-N-O-T-H-I-N-G

A  
MAN  
ATE  
NOTHING

for lunch for 10 days but GRAPE-NUTS and cream. He had been “running down” on meat and potatoes.

He gained 4 pounds in the 10 days by the change.

GRAPE-NUTS food is *all* nourishment and *all* of it goes into the proper place. That’s why **one** pound of GRAPE-NUTS contains more available nourishment than **ten** pounds of Meat, Wheat, Oats or Bread. Proved by trial.

## COCOA OF PURITY

*Angler's*



YOUR  
GROCER  
SELLS IT.

UNSURPASSED.

# VOSE

## PIANOS

have been established over 50 YEARS. By our system of payments every family in moderate circumstances can own a VOSE piano. We take old instruments in exchange and deliver the new piano in your home free of expense. Write for catalogue D and explanations.

VOSE & SONS PIANO CO., 160 Boylston St., Boston, Mass.



# RECREATION

MY DOG FOSS;  
By GEORGE E. DODS, with full page drawing by W. H. LAWRENCE,  
and other illustrations.

OFFICIAL ORGAN OF THE LEAGUE OF AMERICAN SPORTSMEN

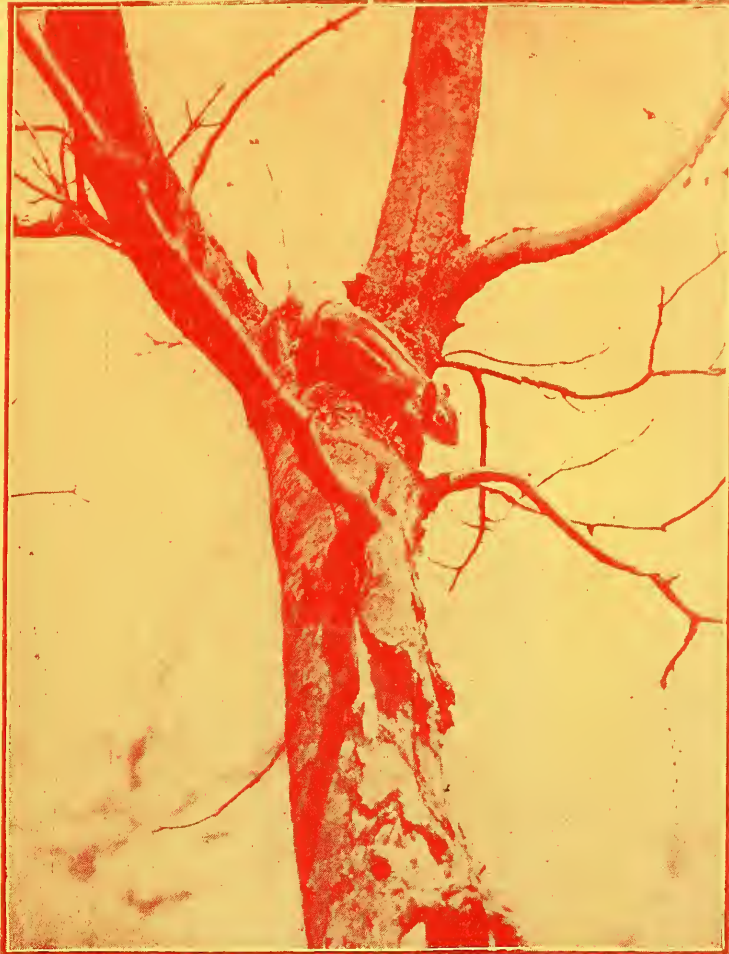

AMATEUR PHOTO BY R. H. BEEBE.

One of the 18th Prize Winners in RECREATION'S 7th Annual Photo Competition.

PUBLISHED BY G. O. SHIELDS (COQUINA)  
23 WEST 24TH ST., NEW YORK

ANTELOPE HUNTING IN WYOMING;

By E. C. HALL, with full page drawing by CARL RUNGIUS.



**Pabst**  
**Blue Ribbon**  
The Beer of Quality. The  
very life of the malt caught  
and held in absolute pur-  
ity for your delectation.  
*Sold everywhere.*

# RECREATION

Copyright, December, 1902, by G. O. Shields

A Monthly Magazine Devoted to Everything the Name Implies

\$1.00 A YEAR.  
10 CENTS A COPY.

G. O. SHIELDS (COQUINA),  
Editor and Manager.

23 WEST 24TH STREET,  
NEW YORK

## CONTENTS OF THIS NUMBER

PAGE

He Stopped, One Forefoot on the Fallen Trunk, One Reaching for the Ground Beyond....	FRONTISPIECE.		
My Dog Foss. Illustrated.....	GEORGE E. DODS	249	
A Duck-Shooting Reminiscence.....	CAPT. E. L. MUNSON, U. S. A	253	
Antelope Hunting in Wyoming. Illustrated .....	E. C. HALL	255	
The Travels of a Hunting Knife.....	DR. A. J. WOODCOCK	261	
A Morning's Duck Shooting. Illustrated .....	H. W. CLOSS	265	
When the Frost is on the Pumpkin. Poem.....	A. N. KILGORE	266	
Gabe Bear's Baccy.....	THEODORE ROBERTS.	267	
Goose Shooting in Manitoba. Illustrated.....	H. M. LAING	271	
Granddaddy's Ol' Rifle. Poem. Illustrated.....	J. B. ADAMS	274	
The Grizzly's Ghost.....	STANLEY MAYALL	276	
The Duck Shooter's Complaint. Poem.....	A. M. H.	277	
A Night in a Fishing Hut.....	W. ROGERS	279	
The Colonel's Victory .....	A. L. VERMILYA	314	
From the Game Fields.....	283	Forestry.....	308
Fish and Fishing .....	293	Pure and Impure Foods.....	311
Guns and Ammunition .....	295	Editor's Corner .....	313
Natural History.....	301	Amateur Photography.....	320
The League of American Sportsmen .....	305		

Entered as Second-Class Matter at New York Post-Office, Oct, 17, 1894.



**TIDINESS**  
and **COMFORT**  
for all men by using  
**WASHBURNE'S**  
**Cuff Holders**

Instantly Attached or Detached.

Sent Prepaid for . . . . . 20 Cents.  
Scarf Holder . . . . . 10 Cents.  
Key Ring and Chain . . . . . 25 Cents.

*They never come loose—a tiny lever with a bulldog grip.*

Illustrated Catalogue of others on request.

AMERICAN RING CO., Dept. 44, Waterbury, Conn

## Dyspepsia

AND OTHER

## Stomach Troubles

Quickly relieved and positively  
cured by the use of

# "Glycozone"

an absolutely harmless germicide. Subdues inflammation, and by cleansing the membrane of the stomach of abnormal secretions, restores it to perfect health and effects a cure.

For any stomach trouble it will do good, and generally cure.

Used and recommended by leading physicians everywhere for the last 12 years.

Sold by leading druggists, or sent prepaid on receipt of \$1.00.

None genuine without my signature on label.

*Prof. Charles Marchand*

F-59 Prince Street

NEW YORK

# TO AMATEUR PHOTOGRAPHERS

Here is a Chance  
to Get a  
FINE CAMERA EASILY

A 4x5 Weno Hawk-eye film camera listing at \$8, for 5 yearly subscriptions to RECREATION. A No. 3 folding Weno Hawk-eye film camera, listed at \$15, for 10 yearly subscriptions to RECREATION.

These are both neat, compact, well made and handsomely finished cameras, capable of doing high-class work.

*Sample copies for use in canvassing  
furnished on request.*

Address RECREATION

23 West 24th St.

NEW YORK CITY

# Abercrombie & Fitch

World's  
Headquarters  
for  
Fishing Tackle



## A 3 Cent Bait

in postage stamps will bring the biggest catch an angler, camper or sportsman can land—Abercrombie and Fitch's catalogue R, 160 pages, cuts and prices.

We guarantee to furnish a more satisfactory fisherman's outfit than can be obtained elsewhere.

**Complete outfits for explorers, campers and prospectors. Camp outfits from the most modest and practical to the most complete and luxurious.**

Compare our prices on tents, clothing, cooking outfits, folding buckets, camp packs, cots, chairs, food bags, folding shelves, guns, boots, moccasins, sleeping bags, pack saddles, stoves, pneumatic beds, cushions, duffle bags, pack harness, folding bakers, folding lanterns, rolling tables, fishing tackle, shoes, covers, &c.

314-316 BROADWAY, NEW YORK CITY

---

# Decorate Your Den

With a set of the most beautiful  
**Hunting and Fishing Pictures**  
ever made.

---

---

**15 Plates. Size for Framing, 18 x 24 inches**

---

---

SUBJECTS:

<b>ELK HUNTING</b>	<b>SALMON FISHING</b>	} HY. SANDHAM
<b>MOOSE HUNTING</b>	<b>TROUT FISHING</b>	
<b>MALLARD SHOOTING</b>	<b>BLACK BASS FISHING</b>	— C. E. DENTON
<b>TARPON FISHING</b>	<b>BLUE FISHING</b>	— FRED S. COZZENS
<b>ANTELOPE HUNTING</b>	<b>GOOSE SHOOTING</b>	— FRED REMINGTON
<b>GROUSE SHOOTING</b>	<b>WILD TURKEY HUNTING</b>	— R. F. ZOGBAUM
<b>MUSKALONGE FISHING</b>		— F. H. TAYLOR
<b>DEER HUNTING</b>		— A. B. FROST
<b>ROCKY MOUNTAIN SHEEP HUNTING</b>		— E. KNOBEL

These 15 plates are lithographed in true colors of nature and altogether make one of the finest series of pictures of outdoor sports ever published.

**ORIGINALLY ISSUED AT \$50 A SET**

I have bought the last of them and can furnish a complete set for 15 yearly subscriptions to RECREATION,

**Or will Sell at \$10 a Set**

---

I also have enlargements of the following photographs:

**ROCKY MOUNTAIN GOATS**

Published on pages 90, 91, 92, and 93 of the February issue of RECREATION,  
\$5 a set.

**WOOD DUCK SHOOTING**

Published on page 95 of the February issue of RECREATION, \$1.50 each.

---

---

**Address: RECREATION, 23 West 24th Street, New York City**

# A SUMMER PARADISE

**GRAND  
TRUNK  
RAILWAY  
SYSTEM**

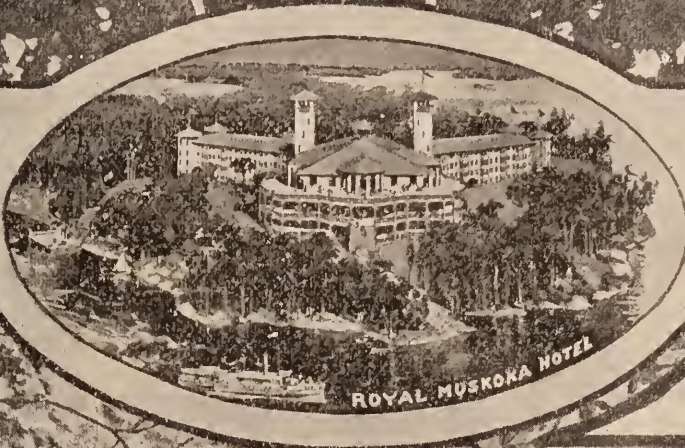

## HIGHLANDS OF ONTARIO

1000 FEET ABOVE SEA LEVEL.  
 MOST CHARMING SUMMER  
 RESORTS IN AMERICA  
 INCLUDING  
 MUSKOKA LAKES  
 LAKE OF BAYS  
 MAGNETAWAN RIVER  
 30,000 ISLANDS OF GEORGIAN  
 BAY  
 KAWARTHA LAKES  
 LAKES SIMCOE  
 AND COUCHICHING  
 LAKE NIPISSING  
 AND FRENCH RIVER

EASY OF ACCESS. PERFECT IMMUNITY FROM HAY FEVER.  
 GOOD HOTEL ACCOMMODATIONS.  
 RATES TO SUIT ALL POCKETS.

THE "ROYAL MUSKOKA"  
 FINEST SUMMER HOTEL IN CANADA.

### FREE ILLUSTRATED PUBLICATIONS

CAN BE HAD FROM GRAND TRUNK RAILWAY  
 SYSTEM. ADDRESS NEAREST OFFICE.

BOSTON, MASS.	T. Wynne	256 Washington Street
BUFFALO, N. Y.	Chas. E. Coon	283 Main St. (Elliot Square Bldg.)
CHICAGO, ILL.	G. W. Vaux	911 Merchants Loan and Trust Building
DETROIT, MICH.	J. H. Burgess	249 Clark St. (cor. Jackson Boulevard)
LOS ANGELES, CAL.	Geo. W. Watson	124 Woodward Avenue
MONTREAL, QUE.	W. H. Bullen	372 Wilcox Building, Bonaventure Station
NEW YORK, N. Y.	J. Quilley	137 St. James Street
SAN FRANCISCO, CAL.	W. H. Clancy	Dun Building, 259 Broadway
ST. PAUL, MINN.	E. P. Deyer	12 Front Street
TORONTO, ONT.	W. A. Johnson	111 Eastlight Arcade, Union Station
	J. D. McDonald	N. W. cor. King and Yonge streets
	J. W. Ryder	

OR TO G. T. BELL,  
 GENERAL PASSENGER AND TICKET AGENT.  
 MONTREAL, CANADA.  
 MENTION THIS MAGAZINE.



Are You an  
Amateur  
Photographer?

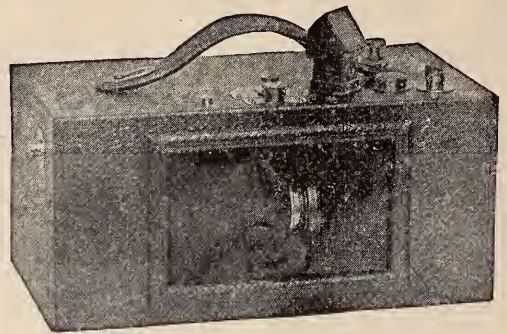

If so would you like a Camera  
that will photograph

A whole range of mountains  
A whole sweep of river  
A whole army  
A whole fleet of ships  
A whole city

Or any other vast stretch of scenery or moving  
objects? THE SWING LENS DOES IT

The **Al Vista**

Is the thing. It lists at \$30

One of the greatest inventions of the age.  
Given as a premium for 12 subscriptions.

For particulars Address

**RECREATION**

23 West 24th Street

NEW YORK CITY



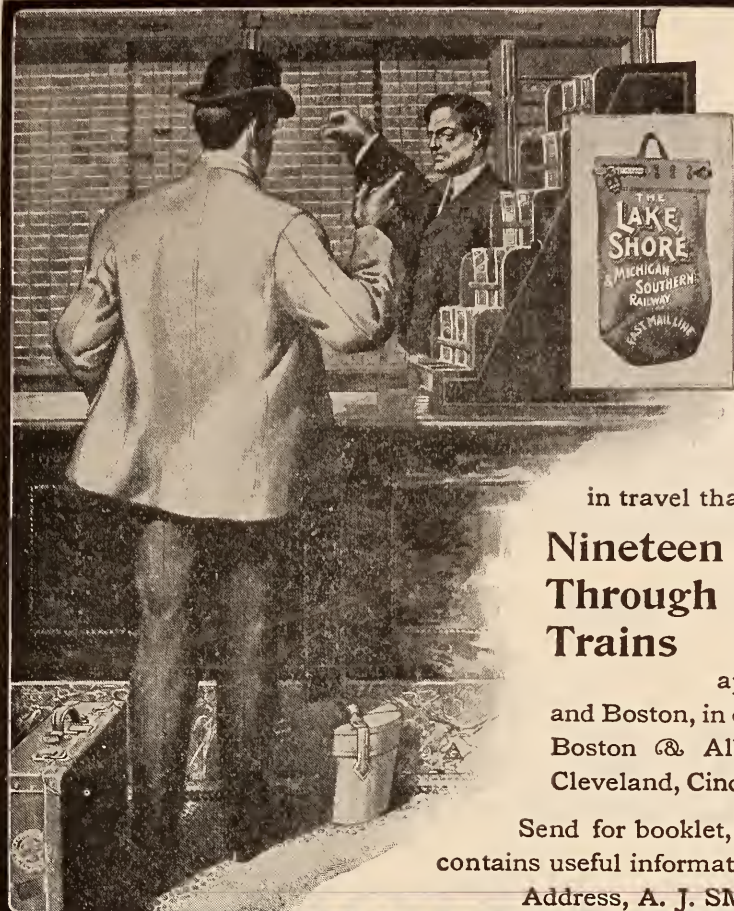

# Don't Forget!

WHEN YOU BUY a ticket don't forget to tell the ticket agent plainly that you wish it over the Lake Shore & Michigan Southern Railway. You will secure the best in travel that money can buy.

**Nineteen Through Trains** In daily service over the Lake Shore & Michigan Southern Railway between the cities of Chicago and Toledo, Cleveland, Buffalo, St. Louis, Indianapolis, Cincinnati, Pittsburg, New York and Boston, in connection with the New York Central, Boston & Albany, Pittsburg & Lake Erie and Cleveland, Cincinnati, Chicago & St. Louis Railroads.

Send for booklet, "Privileges for Lake Shore Patrons," contains useful information; also "Book of Trains."

Address, A. J. SMITH, G. P. & T. A., Cleveland, Ohio

## WANT A REEL?

You can get one for nothing.  
Or at least for a few hours' work.

Send me

15 Yearly Subscriptions

to

# RECREATION

and I will send you

## A TALBOT REEL

Listed at \$20.00

Made by W. H. Talbot, Nevada, Mo.

This is one of the finest pieces of fishing tackle ever made. It is built like a gold watch. Equal to any Kentucky reel you ever saw.

**In Tournaments, Always a Victor  
Among the Angler's Treasures, Always the Chief**

I have but a few of these reels in stock and this offer will be withdrawn as soon as the present supply is exhausted.

Sample copies of RECREATION for use in canvassing furnished on application.

## 77 Information

### Bureaus of the

### New York Central Lines

Each city ticket office of the New York Central, Boston & Albany, Michigan Central, Lake Shore, Big Four, Pittsburg & Lake Erie, and Lake Erie & Western Railroads in the cities of New York, Brooklyn, Boston, Worcester, Springfield, Albany, Utica, Montreal, Syracuse, Rochester, Buffalo, Niagara Falls, Toronto, Detroit, Cleveland, Pittsburg, Columbus, Indianapolis, Cincinnati, Louisville, St. Louis, Chicago, Denver, San Francisco, Portland, Los Angeles and Dallas, Texas, is an information bureau where desired information regarding rates, time of trains, character of resorts, hotel accommodations, and a thousand and one other things the intending traveler wants to know will be freely given to all callers.

A copy of No. 5 of the "Four-Track Series," "America's Winter Resorts," will be sent free, post-paid, to any address, on receipt of a postage stamp, by George H. Daniels, General Passenger Agent, New York Central & Hudson River Railroad, Grand Central Station, New York.

# DO YOU WANT A FOLDING CANVAS BOAT ?

If. So, Send Me

## 35 Yearly Subscriptions to RECREATION

AND I WILL SEND YOU

### A 14 ft. King Folding Canvas Boat

LISTED AT \$48

capable of carrying 2 men and an ordinary camp outfit. There are thousands of these boats in use, and nearly every man who is using one of them praises it on every occasion.

Sample copies of RECREATION for use in canvassing will be furnished on application.

Address 23 West 24th St., New York



# SHOOTING JACKET

**\$3.00**

---

---

**G**UARANTEED all wool, seamless, elastic, close fitting, but not binding, comfortable and convenient. Designed especially for duck shooters, trap shooters, etc., but suitable for all outdoor purposes. Must be seen to be appreciated. Made only in two colors—dead grass and Oxford Gray.

Send us your address for one of our Gun Catalogs.

Mention RECREATION.

**THE H. H. KIFFE CO.**

523 Broadway, New York

# ANOTHER GREAT OFFER TO AMATEUR PHOTOGRAPHERS

A 4 X 5 SERIES 1 KORONA CAMERA  
LISTED AT \$12, FOR 8 YEARLY SUBSCRIPTIONS TO *RECREATION*;

A 5 X 7 SERIES 1 KORONA CAMERA  
LISTED AT \$16, FOR 12 YEARLY SUBSCRIPTIONS;

A 4 X 5 SERIES 2 KORONA CAMERA  
LISTED AT \$18, FOR 14 YEARLY SUBSCRIPTIONS;

A 4 X 5 SERIES 3 KORONA CAMERA  
LISTED AT \$22, FOR 18 YEARLY SUBSCRIPTIONS;

A 4 X 5 SERIES 4 KORONA CAMERA  
LISTED AT \$25, FOR 20 YEARLY SUBSCRIPTIONS;

A 4 X 5 SERIES 5 KORONA CAMERA  
LISTED AT \$35, FOR 30 YEARLY SUBSCRIPTIONS.

*SAMPLE COPIES, FOR USE IN CANVASSING,  
FURNISHED FREE.*

A D D R E S S

## R E C R E A T I O N

23 WEST 24TH STREET, NEW YORK CITY



THE  
WORLD'S  
STANDARD



THEY'RE MADE TO MEASURE

# Putman Boots.

Go on like a glove *and* fit all over.

For a **Quarter of a Century** Putman Boots have been the Standard among Western Hunters, Prospectors, Ranchmen and Engineers (who demand the best) and we have learned through our personal contact with them **how** to make a perfect boot.

Putman Boots are in use in nearly every civilized country in the World. They are Genuine Hand Sewed, Water proof, Made to measure, Delivery charges prepaid, and cost no more than others. Send for Catalogue of over **30 different styles** of boots. Also **Indian Tanned Moosehide Moccasins**. We send with catalogue Order Blanks showing how to measure your foot.

We have in our files thousands of letters similar to the following.

GENTLEMEN:—Please send me another catalogue. We are all wearing Putman Boots and find them far superior to any other boot. I have ordered about 20 pairs for friends here during the past three years, and every pair has given perfect satisfaction, and I feel that I have done a man a favor when I have recommended your goods to him.

Respectfully,  
W. H. FLUKER, Gen. Mgr,  
(Columbia Mining Co.)  
Tatham, Ga.

GENTLEMEN:—I have just returned from a duck hunt in Colleton Co. this state, and though I tramped through the marshes for six days and a part of the nights, sinking in mud and water nearly to the tops of the shoes I got from you, my feet kept dry throughout the trip and the shoes were as soft at the wind-up as at the beginning. I can cheerfully recommend your shoes to all sportsmen. Yours respectfully,

C. F. DILL,  
Greenville, S. C.

GENTLEMEN:—Was fishing through the ice on the Flathead River this week standing for hours in wet snow and slush and tramping through the mountains, and I found the boots you built for me in December to be thoroughly water and snow proof, and quite warm. Yours truly,

L. R. FOGLE, Great falls, Mont.

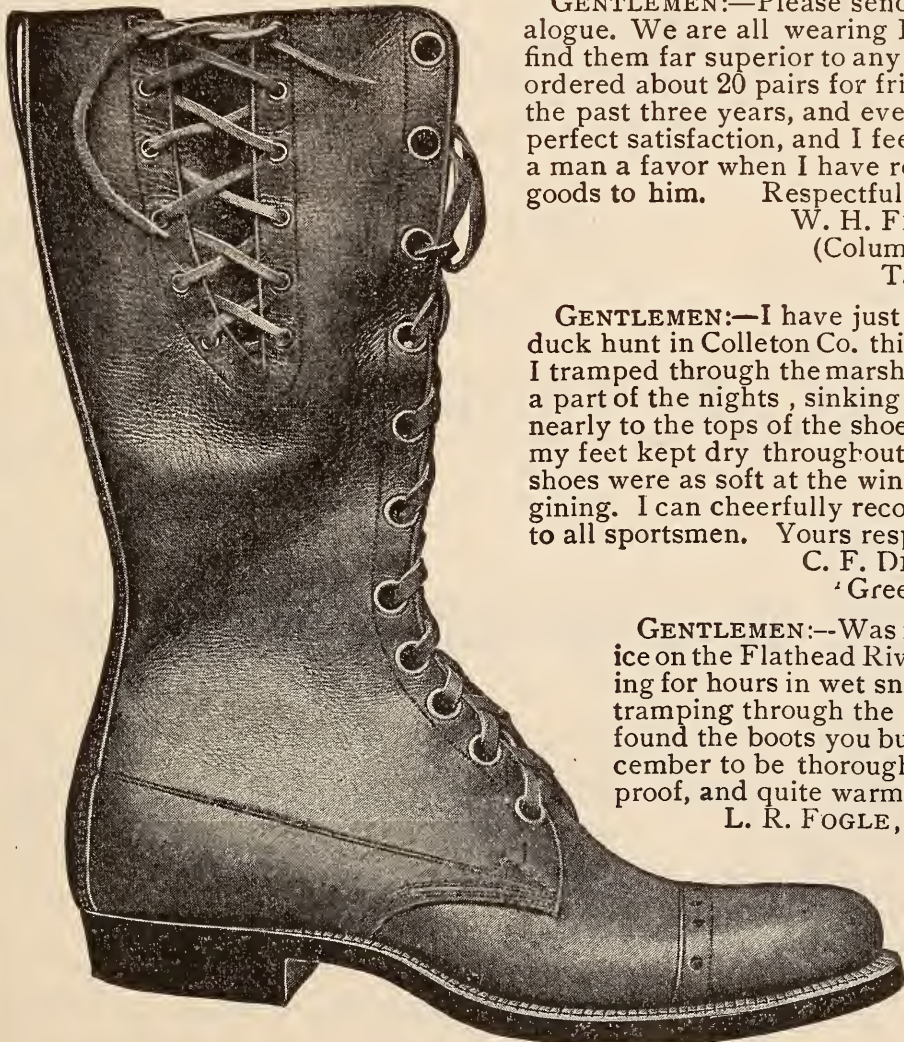

Illustration shows  
No. 900, 14 inch  
Boot, made to measure  
and delivered  
in U. S. for

**\$7.50.**

**H. J. PUTMAN & CO.,**

36 HENNEPIN  
AVE.

**Minneapolis, Minn.**

---

STILL ANOTHER GREAT OFFER

**A Grade O Syracuse Gun**

*Listed at \$31.*

FOR

*25 Yearly Subscriptions*

TO

**Recreation**

If you Want one of the Guns get a move on you

Sample copies for use in canvassing  
furnished on application

---

---

**RECREATION, 23 W. 24th Street, New York**

# Ever been there Friend?



If so you know that you can't get through without an axe.

## Marble's Safety Pocket Axe

is the way out of difficulties.

Large enough to fell a tree, build a camp or quarter a deer. Small enough to go in the pocket. Send for Catalogue.

SOLD BY DEALERS OR DIRECT FROM THE  
**MARBLE SAFETY AXE CO.,**  
GLADSTONE, MICH.

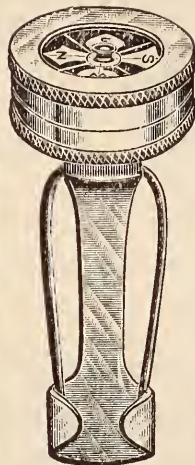
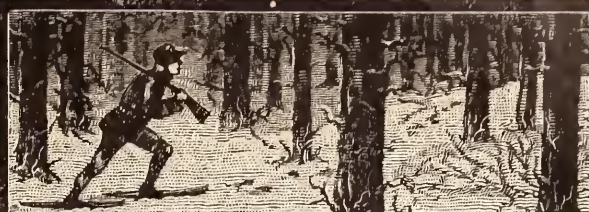

Cut 1/2 actual Size.

**W**ISE men don't go hunting, or fishing, or camping, or yachting, or prospecting, without a compass.

## MARBLE'S HANDY COMPASS

attaches to outside of coat or vest. Always in sight. Cannot be lost, cannot be demagnetized. Thoroughly reliable. Price with revolving card and jeweled needle, \$1.50. With plain jeweled needle, \$1.25.

Send for Catalogue. A  
FOR SALE BY DEALERS, OR  
**MARBLE SAFETY AXE CO.**  
GLADSTONE, MICH.



# The Rocky Mountain Goat

Is a shy, wary animal that ranges 8,000 to 15,000 feet above sea level

and has rarely been photographed, Mr. A. M. Collins, one of RECREATION's prize winning photographers has recently made 4 of the finest goat pictures ever produced. I HAVE had enlargements made from these, 13 x 15 inches, and will sell them

**At \$5.00 a Set.**

A rare and valuable group for sportsmen, amateur photographers and nature students. Address

**RECREATION,** 23 WEST 24th ST.  
NEW YORK CITY

The Celebrated

# THOMPSON-QUIMBY

Hunting Boots, Shoes and Moccasins

THOMPSON



PSON

*All Work Guaranteed*

I have on file measurements of all who bought Boots and Shoes of the W. Fred Quimby Co., of New York for the past 20 years, and I make the same grade of sportsmen's footwear as they made. I was superintendent of the shoe department of that firm and bought the right to make these boots and shoes. Get a pair now. They will last years and are the cheapest in the end. I refer by permission to the Editor of RECREATION.

Measurement blanks and prices on application. Mention RECREATION.

**T. H. CUTHRIE**  
33 William Street, NEWARK, N. J.

**"FOR 34 YEARS A STANDARD PIANO."**

# THE WING PIANO

**YOU NEED THIS BOOK** IF YOU INTEND TO BUY A PIANO. A book —not a catalogue—that gives you all the information possessed by experts. It makes the selection of a piano easy. If read carefully, it will make you a judge of tone, action, workmanship and finish; will tell you how to know good from bad. It describes the materials used; gives pictures of all the different parts, and tells how they should be made and put together. It is the only book of its kind ever published. It contains 116 large pages, and is named "**The Book of Complete Information About Pianos.**" We send it free to anyone wishing to buy a piano. Write for it.

**SAVE FROM \$100 TO \$200** We make the WING PIANO and sell it ourselves. It goes direct from our factory to your home. We do not employ any agents or salesmen. When you buy the WING PIANO you pay the actual cost of construction and our small wholesale profit. This profit is small because we sell thousands of pianos yearly. Most retail stores sell no more than twelve to twenty pianos yearly, and must charge from \$100 to \$200 profit on each. They can't help it.

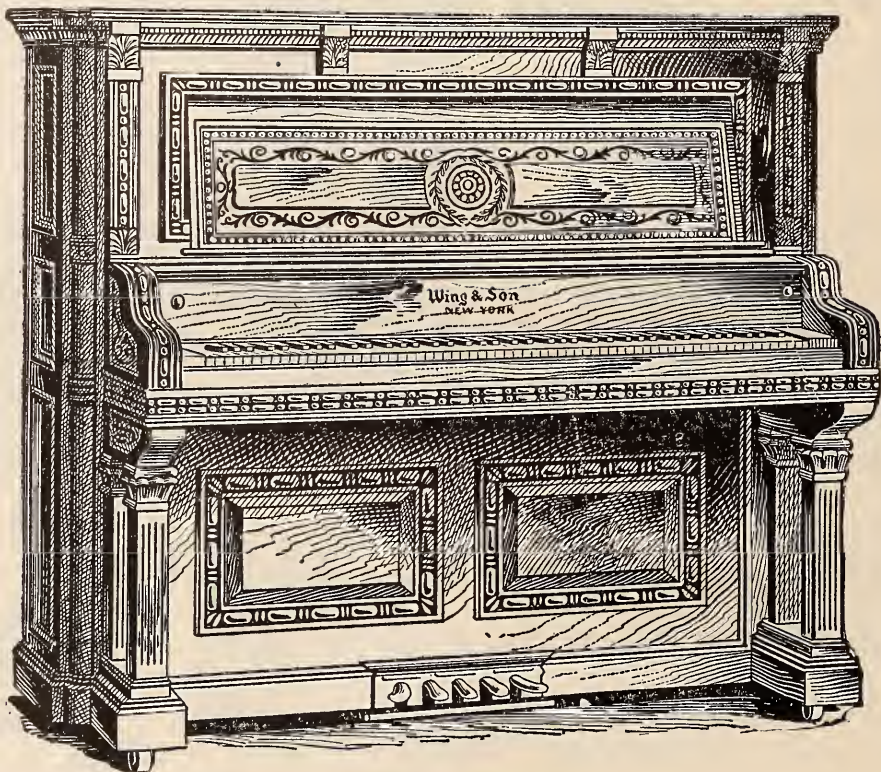

*A Wing style—45 other styles to select from.*

**SENT ON TRIAL** WE PAY FREIGHT. NO MONEY IN ADVANCE. We will send any WING PIANO to any part of the United States on trial. We pay freight in advance and do not ask for any advance payment or deposit. **If the piano is not satisfactory after twenty days' trial in your home, we take it back entirely at our expense.** You pay us nothing unless you keep the piano. There is absolutely no risk or expense to you.

Old instruments taken in exchange.

**EASY MONTHLY PAYMENTS.**

**INSTRUMENTAL ATTACHMENT** A special feature of the Wing Piano; it imitates perfectly the tones of the mandolin, guitar, harp, zither and banjo.

**IN 34 YEARS 33,000 PIANOS** We refer to over 33,000 satisfied purchasers in every part of the United States. WING PIANOS are guaranteed for twelve years against any defect in tone, action, workmanship or material.

**WING ORGANS** Are just as carefully made as Wing Pianos. They have a sweet, powerful, lasting tone, easy action, very handsome appearance, need no tuning. Wing Organs are sold direct from the factory, sent on trial; are sold on easy monthly payments. For catalogue and prices write to

**WING & SON,** 432 and 434 West 13th St.,  
NEW YORK.

1868—35th Year—1903.



# Sent on Approval TO RESPONSIBLE PEOPLE Laughlin

## Fountain Pen

Guaranteed Finest  
Grade 14k.  
SOLID GOLD PEN.

To test the merits of

### RECREATION

as an advertising medium  
we make this grand special offer, your choice of

These  
Two Popular Styles  
For Only **\$1.00**  
Postpaid to any Address

(By Registered mail 8 cents extra)

Holder is made of finest quality hard rubber, in four simple parts, fitted with very highest grade, large size 14k, gold pen, any flexibility desired—in feeding device perfect.

Either Style—**RICHLY GOLD MOUNTED** for presentation purposes, \$1.00 extra.

### Grand Special Offer

You may try the pen a week; if you do not find it as represented, fully as fine a value as you can secure for three times the price in any other makes, if not satisfactory in every respect, return it and we will promptly refund your money.

Illustration on left is full size of Ladies' style; on right, Gentlemen's style. Lay this RECREATION Down and Write NOW.

Safety Pocket Pen Holder sent free of charge with each Pen.

ADDRESS :

## Laughlin Mfg. Co.

424 Griswold St., DETROIT, MICH.



### The Best of Good Company

is always at your command if you've a Combination Table in your home. A handsome library or dining table changed to billiards or pool by removing top. The

### Indianapolis Combination Table

Library—Dining—Billiard—Pool.

is the equal of the finest standard table except in size which is suited to the home. Vermont slate bed, sensitive rubber cushions, imported French billiard cloth, genuine ivory billiard balls, balanced cues. *Nine styles.*  $\frac{3}{8}$ ,  $\frac{3}{4}$ ,  $\frac{7}{8}$  standard billiard table sizes. The correct table for your library or dining room is among them.

Write for our new illustrated catalogue and full information. Combination Billiard Mfg. Co., 33-43 Ingalls Street, Indianapolis, Ind.

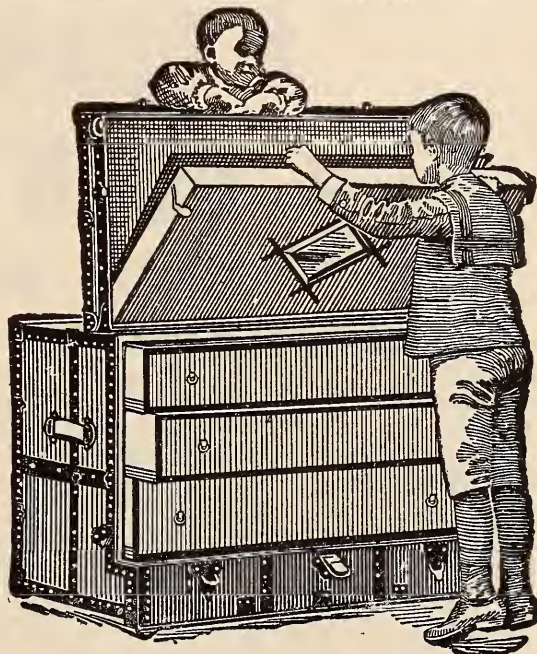
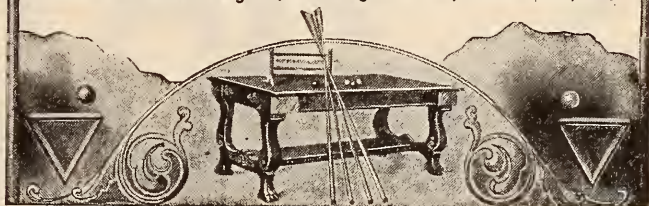

**Stallman's Dresser Trunk** Have you seen one? It is up-to-date. Think of it, everything within reach. No heavy trays, but light, smooth drawers. Holds as much and costs no more than a good box trunk. Hand riveted, almost indestructible. Once tried, always recommended. Sent C. O. D., privilege examination. ac. stamp for catalogue. Mention RECREATION.

F. A. STALLMAN.

87 W. Spring St.,

Columbus, O.

# UNCLE SAM SAYS IT'S ALL RIGHT.

Uncle Sam in the person of Ten Government Officials, has charge of every department of our distillery. During the entire process of distillation, after the whiskey is stored in barrels in our warehouses, during the seven years it remains there, from the very grain we buy to the whiskey you get, Uncle Sam is constantly on the watch to see that everything is all right. We dare not take a gallon of our own whiskey out of our own warehouse unless he says it's all right. And when he does say so, that whiskey goes direct to you, with all its original richness and flavor, carrying a **UNITED STATES REGISTERED DISTILLER'S GUARANTEE** of **PURITY** and **AGE**, and saving the dealers' big profits. That's why **HAYNER WHISKEY** is the best for medicinal purposes. That's why it is preferred for other uses. That's why we have half a million satisfied customers. That's why **YOU** should try it. Your money back if you're not satisfied.

# HAYNER WHISKEY

**1 QUART \$1.00**

**4 QUARTS \$3.20**

**WE PAY EXPRESS CHARGES IN EITHER CASE.**

Send us **\$1.00** for **ONE QUART** or **\$3.20** for **FOUR QUARTS** of **HAYNER SEVEN-YEAR-OLD RYE**, and we will pay the express charges. We ship in a plain, sealed package; no marks to even suggest contents. If you don't find it all right and better than you can buy from anybody else for double the money, ship it back to us at our expense and your money will be promptly refunded. We ship one quart on your first or trial order only. All subsequent orders must be for at least 4 quarts at 80 cents a quart. The packing and express charges are almost as much on one quart as on four and even at \$1.00 for one quart we lose money, but we want you to try it. **WE PREFER TO HAVE YOU ORDER FOUR QUARTS FOR \$3.20 RIGHT NOW FOR THEN WE WILL MAKE A LITTLE PROFIT AND YOU WILL ALSO SAVE MONEY.**

Trial orders for Ariz., Cal., Col., Idaho, Mont., Nev., N. Mex., Ore., Utah., Wash., or Wyo., must be 1 Quart for \$1.25 by **EXPRESS PREPAID**. Subsequent orders on the basis of 4 QUARTS for \$4.00 by **EXPRESS PREPAID** or 20 Quarts for \$16.00 by **FREIGHT PREPAID**.

Remit by Check, Bank Draft, Express or Money Order. It is unsafe to send currency unless you register your letter. Write our nearest office and do it **NOW**.

ESTABLISHED  
1866.

**THE HAYNER DISTILLING COMPANY,**

**DISTILLERY  
TROY, OHIO.**

**DAYTON, OHIO.**

**ST. LOUIS, MO.,**

**ST. PAUL, MINN.,**

**ATLANTA, GA.,**







IN THE ACT OF CROSSING A MOSSY LOG HE STOPPED, ONE FORE FOOT ON THE FALLEN TRUNK, ONE FORE FOOT ON THE GROUND BEYOND.

# RECREATION

Volume XIX.

OCTOBER, 1903

Number 4.

G. O. SHIELDS, (COQUINA) Editor and Manager

## MY DOG FOSS.

GEORGE E. DODS.

Ever since I can remember, my favorite sport has been found afield with dog and gun. Doubtless I at first hunted for the hunting's sake; taking more delight in a full game bag than in a fruitless chase. Later I hunted because I loved to watch my dog overmatch the cunning of the game; because I loved the damp, earthy fragrance of the woods; and, most of all, perhaps, because I loved the birds themselves. When one es-

ing gun to shoulder. When someone invents a camera that will catch a wary grouse awing, I shall dedicate my gun solely to the destruction of bird enemies.

My favorite game bird has always been the ruffed grouse. I have always delighted in the study of his habits in drumming time, in nesting time, and then in the rich, brown autumn, the hunting time *par excellence* of all the year.

Most wisely has the League of American Sportsmen chosen the ruffed grouse as its emblem, for he is easily the King of American Game Birds.

I have had many dogs; good, bad and indifferent. Now I have at last a dog that a white man can love without condescension. Many are the men who think they own the best dog in the world. They are mistaken; I own him myself. He is an Irish setter, now 2 years old, and his name is Foss. I bred and trained him and am more than proud of it. He never saw a grouse until last fall, and the I spent a few seeing it was thus:

With my friends, Charlie and Rod, manner of his days in Broome county, N. Y. Though the weather was unfavorable during our stay, we had a good time. I, thanks to Foss, had exceptional sport. We put up with a genial old farmer, who did his best to make things pleasant.

When Charlie and I introduced the dog to the grouse, the farmer was with us. He had listened smilingly to my praise of Foss. He said he



AMATEUR PHOTO BY E. H. NELSON

ON HIS FAVORITE LOG.

Winner of 24th Prize in RECREATION'S 7th Annual Photo Competition.

aped the whistling shot I saw him disappear without regret and wished him continued luck. And now, were it not for disappointing my faithful dog, I should be well content to flush the birds and watch their hurtling, meteoric flight to cover, without lift-



AMATEUR PHOTO BY GEO. C EMBODY

#### RUFFED GROUSE ON NEST.

One of the 22d Prize Winners in RECREATION'S 7th Annual Photo Competition.

had seen fellows miss birds before, but he loved good company and if it was distinctly understood that he was to go with the pup, he didn't mind going.

The cleared field of the farm ran back to a big stretch of broken country full of abrupt little hills, and steep ravines guiding narrow, noisy brooks. It was heavily timbered, mostly with hard woods, though here and there were old clearings thickly grown with young cedar. Dense underbrush choked the valleys, and the hills were everywhere a tangle of laurel. It was the place to find ruffed grouse, and to lose them again.

In almost the first ravine we crossed a bird burst like a bombshell from the cover and as instantly disappeared, leaving us to guess his direction from the dwindling roar of his flight. He looked as big as a turkey and was apparently going a mile a minute. Charlie fired, but it must

have been on general principles, for he could not have had time to raise his gun. The farmer chuckled.

"You're mighty quick at throwing away shot, young man," he said. "I think I know where that fellow headed; bring along that wonderful dog, and you can waste another shell."

Swinging well to one side to give Foss the wind, we moved forward, Charlie and I abreast and about 40 yards apart. The farmer, who was hunting with a cane, followed close behind us. Foss, now fairly on the trail of his first grouse, ranged ahead like a veteran. Suddenly he checked, turned to the left and moved deliberately in that direction, his head held high.

"He's got the scent, boy," the farmer whispered. "He knows where the bird is and what's more, knows how to get him."

We had been so intent on the dog's performance that we had ceased fol-



AMATEUR PHOTO BY DAVID SPENCE.

A DRUMMER BOY.

Winner of 38th Prize in RECREATION'S 7th Annual Photo Competition.

lowing him, and he was then 75 or 80 yards in advance.

"This won't do," the farmer whispered again. "You'll not get a shot this way. Can't you call him back?"

"Foss!" I cried, softly.

He stopped and looked at me.

"Come, boy. Back!"

Instantly he came, creeping as softly as before. When within 25 yards I sent him on again, and we followed. When he got a little too far away I had only to say "Whoa" and he would wait for us to come nearer. In that way he led us about 100 yards. In the act of crossing a mossy log he stopped, one forefoot on the fallen trunk, one reaching for the ground beyond. He might have been a graven image, for any motion we could detect; but no image could convey such a suggestion of alertness and nervous tension.

I shall not live long enough to forget that glorious sight; a pup point-



AMATEUR PHOTO BY A. B. GUNDERSON.

A COZY CORNER.

Winner of 23d Prize in RECREATION'S 7th Annual Photo Competition.

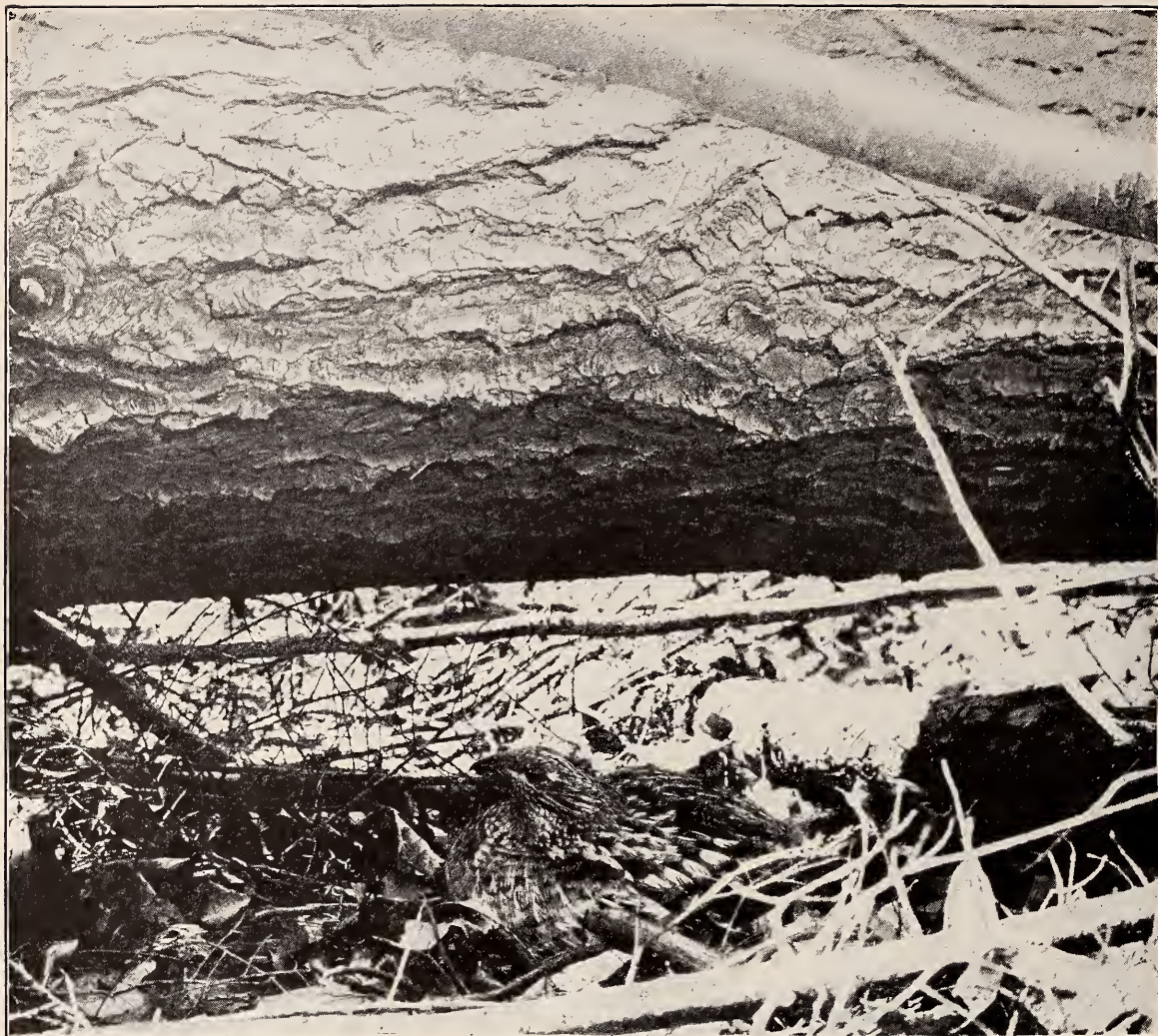

WELL HIDDEN.

AMATEUR PHOTO BY E. P. WORCESTER.

Winner of 28th Prize in RECREATION'S 7th Annual Photo Competition.

ing his first grouse, the point perfection and the pup my own.

We all forgot the bird until it flushed a few yards from the motionless dog. Charlie, who was not dazed with pride, since, poor fellow, he had no claim on Foss, fired first. If ever I wanted to kill a bird it was at that moment; but I was almost as well pleased when the dog dropped instantly to shot. Told to fetch, he brought the bird quietly to me, and I handed it to Charlie. We all patted

and praised Foss, and our farmer friend was fairly enthusiastic.

"By George, boy!" he exclaimed; "you've got a dog with hunting sense and yet willing to be told. That's a rare combination and he ought to make a world beater."

In 7 days' shooting, thereafter, my 2 companions and I killed 24 grouse in that woodland. In all that time I did not have to speak a chiding word to Foss. There will never be enough money coined to buy him.

---

Some men of a Grand Army corps  
Went down where the wild surges ropps,  
To watch for a whale  
Or a sou' wester gale,  
But they all fell asleep on the shorps.



## A DUCK-SHOOTING REMINISCENCE.

CAPT. E. L. MUNSON, U. S. A.

One bright October afternoon I loped the hunting pony over the 4 miles of prairies to Big Sandy creek, where a sufficient number of ducks could usually be found to ensure fair sport. At that season the creek contained little water and consisted of a series of still pools, lying under abrupt banks several feet in height. There was no cover, save for sparse sage brush and an occasional clump of rose bushes, but the steep character of the banks was such that in most instances it was only necessary for the gunner to locate a flock of ducks in order to arrive within reasonable shooting distance by making a careful detour. The ducks seemed to appreciate the danger of their position and would promptly take wing if a hunter came in sight, no matter at how great a distance he might be. The first part of the problem was therefore for the hunter to see the game before the latter saw him. That was accomplished by following the course of the creek and carefully scrutinizing its surface and margins before rounding its bends or in any way exposing the person.

Reaching the creek, I picketed the pony to a convenient sage bush, put half a dozen smokeless shells into my shot gun, and started for a pool, much favored by mallards, about half a dozen gun shots away. Carefully peering around the bends, I finally located a bunch of large ducks 200 yards distant. Opposite them, the banks of the creek sloped away gracefully on both sides and did not afford the usual opportunity for an approach unseen. About 30 yards back from the ducks, however, there was a small patch of rose bushes of sufficient height to screen a man when lying prone. As the ducks had not been alarmed and were busily feeding, I dropped back out of sight, made a detour far to the rear of the bushes mentioned and advanced behind them to within about 100 yards. At that distance it became necessary to get down on hands and knees, and soon after, to avoid exposure, to lie flat on the ground. As the latter was perfectly level and rising, even a few inches would have brought me into full view of the ducks, I could advance but slowly,

dragging myself along on toes and elbows and pushing the gun ahead of me. As everyone who has tried it knows, this method of progression is most exhausting, and frequent rests were necessary before, at the end of 10 or 15 minutes, the clump of bushes was finally reached. I rose carefully and looked through the tops of the bushes. Six fine mallards, unsuspecting of danger, came into view directly in front of me and about 25 yards distant. As I rose to my knees, the flock jumped into the air and started down the creek, strung out in single file. Pulling the gun well ahead of the leader of the flock, I had the satisfaction of seeing him fall in response to the spiteful crack of the smokeless powder. At the next shot, the second duck in the line collapsed, and at the third shot the leading duck of the remaining 4 fell dead at a distance of nearly 60 yards. Confused at the loss of the 3 leaders, the remaining ducks, just passing out of range, swung short about and turned back up the creek toward me. Pumping forth a shell from the magazine into the chamber, I fired at the leading duck, but missed him, only to kill the one next behind. My fifth shot dropped the rear bird of the 2 survivors, and as the single remaining duck came abreast of me he fell to the last cartridge in the gun. Within a few seconds, the entire flock had thus fallen to 6 consecutive shots, the 6 birds all killed outright and lying within a few yards of one another. They were as fine, fat mallards as one would wish to see; and as I smoothed their gorgeous feathers and thought of the difficult stalking so well done, and the shooting which for rapidity and accuracy I could scarcely hope to duplicate in the future, I presented to myself my most sincere congratulations.

As the pony took his way up the creek bottom toward home, several large flocks of ducks got up only to pitch into pools ahead where their destruction would have been easy; but they did not get a second glance. Game enough had been secured. Nothing would have tempted me that afternoon to fire another shot and perhaps mar the memory of a bit of sport, brief, yet one of the best I had ever enjoyed.

---

Are you a good cook and laundress?  
Do Oi look loike twins?—Life,



FRESH MEAT FOR CAMP.

## ANTELOPE HUNTING IN WYOMING.

E. C. HALL.

The extensive plains of Wyoming, sparsely covered with short but nutritious grasses, and abounding in short growths of sage and greasewood, are the natural habitat of the antelope. Under favorable conditions these beautiful creatures flourish in great numbers. Until recently, particularly in the Northeastern part of the State, a scattered population of cattle ranchers, itinerant freighters passing through to government post, or prospectors crossing from one mountain range to another has permitted the full development of this natural antelope range; but the incoming of small stock owners and o. pioneer grangers just in advance of railroads has materially and fatally affected this condition of affairs, and the antelope, formerly looked on with contempt by cowmen and hunters, accustomed to the choicer meat of larger game, has attained a domestic and commercial value destined to accomplish its early extinction. The most speedy and to ranchmen unsatisfactory step in its extermination is that effected by Indians who come each year from distant agencies and destroy hundreds, both for temporary subsistence and for winter food. The State game laws, while restricting the white resident and instructing him regarding the close season and the number of his kill, have permitted the Sioux, Cheyenne or Crow hunter to come from another State and slaughter without stint. The Indian of to-day makes his appearance with ponies and good wagons in which to store the unfortunate pronghorn when massacred and its flesh made portable by the jerking process. His ambition to kill knows no rest, for even though he takes to his tepee more than his own outfit requires there are numerous kinsmen back on the reservation who can be provided for. In the autumn of '92 the Ogallalla chief, known as Young Man Afraid of His Horses, went with 30 wagons into Northern Wyoming, locating his camp about 12 miles from my ranch, on a range where antelopes were usually abundant. Those people were good Indians, having pulled out from Pine Ridge agency to avoid getting involved in the Wounded Knee trouble: but they were death on the local game. Without positive knowledge of the number of deer and antelopes brought in, I saw enough of their work to estimate the killing at not less than 1,000 head. One buck stated that he had already shot 40 some time before the chief's departure. Nothing is spared by this native hunter out on his annual raid; the wretched does,

dragged down by suckling kids, that the white man would scorn for food, even if compassion did not animate him, are as ruthlessly shot down as any others. It may readily be inferred that raids like that worked no little hardship on those ranchmen who depend largely on the antelope for camp use. The game that in comparatively recent years ranged the country literally in thousands has become both scarce and shy, and the fact of its not distant extermination seems assured.

I have alluded to the circumstances of the invasions of the antelope range by Indians not only because their recurrence is materially felt by settlers, but for the added reason that I feel sympathy and concern for the fate of this interesting animal. Most Western men regard the pronghorn with anything but respect, classing it very low as a meat producer and referring to it contemptuously as a goat. On the contrary, a study of its habits and its pursuit in a fair way has always given me pleasure. In appearance certainly many animals are its inferior, though it must be admitted it is more attractive when alone than when running in large bands. As affording a sport to test the hunter's eye, judgment and rifle, no American game can compete with it. I refer not to the practice of lying in wait along a trail or at a water hole for emigrant bunches, but to the legitimate stalking of single bucks from May till September, when they run more or less alone. After the springing of green grass in early April the antelope, particularly the males and the barren does, improves rapidly in flesh and flavor, much more so than other wild game. Cropping short, like a sheep, the new pasturage soon affords it good grazing, and this tonic, added to the increasing warmth of the season, rapidly changes its appearance. The process of shedding, as with other animals, is not interesting, and the antelope often presents a curious appearance from the matted hair and inner winter's wool rolled up and clinging to its body. The hair along the back and sides is at all times easily detached, but in May it can be removed by handfuls and annoys the hunter not a little in dressing a carcass. Unlike the deer tribe, this beast sheds its horns in December and January, and at the period when the blacktail and whitetail bucks secrete themselves, seemingly humbled by the defenceless condition of their antlers, the pronghorns are matured and the male carries his perfect head with conscious pride.

Should the ranchman be out of meat about the first of June he may feel certain he will find the buck antelope in good order. It is then readily distinguishable, even at a distance, by its full size, full horn and solitary habit, though often 2 or 3 old males will range together.

Taking from the rack his heavy Winchester and with mind made up for sport and good meat our Nimrod saddles his hunting pony and strikes out toward some favorable rolling country. A good knife and steel hanging to the cartridge belt and a pair of light field glasses carefully cased and fastened to the saddle show that he is well outfitted. The animal he bestrides does not resemble the one described by Mr. Roosevelt as accompanying him on hunting trips. He is either a horse that has served his time in some cow outfit, or he is out of an Indian camp. Insensibility to sound and smell and indifference to the character of his pack are his most praiseworthy traits. In the spring months surface water is plentiful and the buck antelopes range wide and free; whereas the females, selecting some coulee convenient to a watering place, hold their ground until kidding unless disturbed, frequently in company with their 2 yearlings. While enjoying the bracing air, the freshness of the grasses, the note of the prairie birds as they rise at his approach, and all those sights and sounds that produce the indescribable exhilaration which comes to one riding over the open plains, our hunter is watchful.

As each roll of the prairie is attained he takes heed to his surroundings. In hunting pronghorns a good deal of ground may be covered, and the most zealous sportsman may get careless; so it is not strange that the rider on passing over a rise at an unlucky trot sees in the coulee below him a good buck lying comfortably. The handsome beast rises slowly, staring at the intruder, but when once on his feet seems electrified, wheeling and starting like a quarter-horse, and with head thrown forward passing up the opposite slope.

"Luck! luck! what a head!" exclaims our man, as he checks his horse and pulls at his gun at the same instant. The coolest hands are sometimes faulty, and before the ground is attained and the rifle extended the quarry shows up strong and fast on the top of the ridge.

"I might spike him. 'Twould only spoil meat, though," is his mental ejaculation. Then, as he regains the saddle, he philosophizes a little.

"I reckon if I want an even break on this hunt I'd better keep that gun handy and not under my leg."

Following a veteran antelope that has been once jumped is not a profitable move

unless a considerable detour can be made and the game approached from an opposite direction; so our ranchman, getting concerned about his weekly supply of meat, changes his course and with rifle resting conveniently in front of him is determined that the next animal sighted shall not escape. It is not long before his quick eye catches the familiar red and white object resting in a grassy pocket at the base of a distant butte. If it is only a buck its death is certain, for ground and wind favor an approach within easy range. The glasses are quickly resorted to but even their aid fails to determine the fact to a certainty. As another long and cautious look is taken a diminutive form rises from the grass near the larger animal and then another.

"Ah! pappoose! That settles the question. You're safe from me, old lady. If only some bloody Indian doesn't take you in!"

A doe and 2 fawns have proved to be the game in sight and with the above humane soliloquy the hunt is resumed, though the approaching sunset soon compels a return in the direction of the ranch. Dissatisfied and evidently out of luck the horsemen jogs along, thinking he will have to go another week on bacon straight, as he will be too busy to go out again. To add to his discomfiture 2 proud old bucks look up from their grazing in a shallow sag on the broad bench land he happens to be crossing, and after coolly surveying their enemy from a safe distance, gallop leisurely away. To be a successful hunter one must think quickly and be of ready resource; at times take desperate chances. Our hunter is of this class and in this instance his intimate knowledge of the country and prompt action illustrate the point.

"If they go off the bench as they are headed and do not turn down the big draw they will pull for the gap between the red hills. I believe I can head them yet."

His thoughts are rapid but his movements unchanged, following slowly the retreating game. The instant, however, that the hindmost buck pitches off the bank the pony is turned and told to hit the breeze, which he does with astonishing vigor. His experienced eye has also seen the antelope disappear and he seems to know that the moment for a quick move has arrived. Down the bench slope he goes at a rate not warranted by his spring knees and little, splinty legs. The base of a long ridge separating them from the route of the quarry is traversed at frantic speed until, a full thousand yards away, at its terminal point, a large bill is reached between which and a companion butte lies the pass through which it is expected the bucks may go. Riding as far around the foot of the hill as he dare, the anxious hunter

quits his horse and hurriedly advances for a favorable position.

"The devil! they're right here! On a lope too! Now, my boy, cool your nerve and down one! You'll get no more chances."

Such are his mental utterances as he steadies himself for a running shot. The wily animals have made for the gap at a gallop, intending to reach the more open and safer prairie beyond, and catching sight of danger they show prodigious speed, but continue, with a fatality peculiar to their species, the same course, one directly behind the other. As they come abreast of the hunter at 120 yards the first chance is taken; no easy one at that range and pace. A little cloud of yellow dust over and beyond the foremost buck shows a clean miss. Close, though; and animating the fleeing beasts to further effort. Terrified by the passage and shock of the ball, they describe a wonderful side curve and then straighten on the same line. Once more the hunter checks his breath and with a feeling that he must not fail, again throws down on the leader.

"Good leather! A broken neck! I'll gamble on it."

A complete somersault and a long slide in full career of the animal shot at justify the exclamation. Casting a second look to see that the work is fatal the sportsman hurries to his horse, returning to bleed and dress the game.

Some men can not resist the temptation to continue firing as long as anything remains in sight. Not so our ranchman. No needless slaughter can be laid at his door. Approaching the prostrate antelope, gasping in its final struggles, he marks the fatal neck wound and opened jugular, the most desirable shot that can be made on large game. As he touches the knife

on the steel, preparatory to dressing, he can not help pausing a moment to note the changing expression of the creature's eye. The wonderful prominence of this organ with its wild and lustrous qualities call up a compassionate thought at the untimely fate of so magnificent an animal and prove a sportsman's heart. The acts of disembowelling and of unjointing the legs at knee and hock is skillfully performed and the head, a good one, is cut off close to the shoulders.

"Now, Crow-fly-high, step up and take your load."

The pony thus addressed is led to the carcass, where after one enquiring glance and sniff, to assure himself it is only a dead antelope, he stands quietly to be packed. The body, thrown behind the saddle and lashed fast by knee and hock joints to the hind cinch rings, is of itself an ample load; but the added weight of the rider and his gun does not seem to discourage the little brute as he steps off bravely for camp in the gathering dusk. Arrived at the ranch the spoils are hung up to cool over night. At dawn they are skinned, quartered and placed in sacking in the shade to avoid flies. Each night at sundown the meat is exposed and at sunrise, when still cool, re-sacked. By that treatment it may be kept untainted a fortnight during summer in that wonderful climate.

Such used to be a common incident in the life of the Wyoming rancher, whose table required wild meat after the buffalo had departed. Unfortunately there are many times when a less skillful and humane method tends toward the ultimate extermination of the pronghorn. The moderate demand and sportsmanlike dealing illustrated in this article would never bring about the extinction of American game.

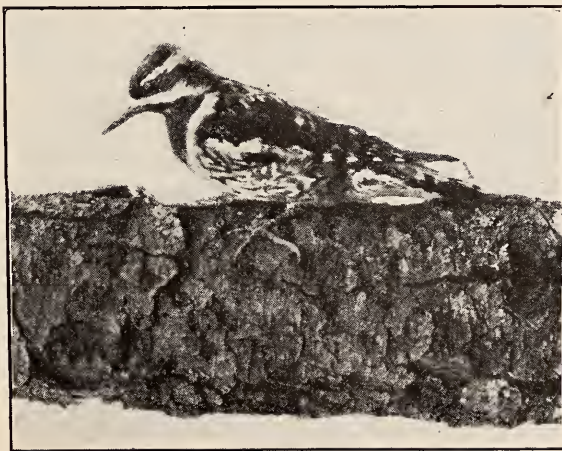

AMATEUR PHOTO BY GEO. C. EMBODY.

YELLOW BELLIED SAPSUCKER.

One of the 22d Prize Winners in RECREATION'S 7th Annual Photo Competition.

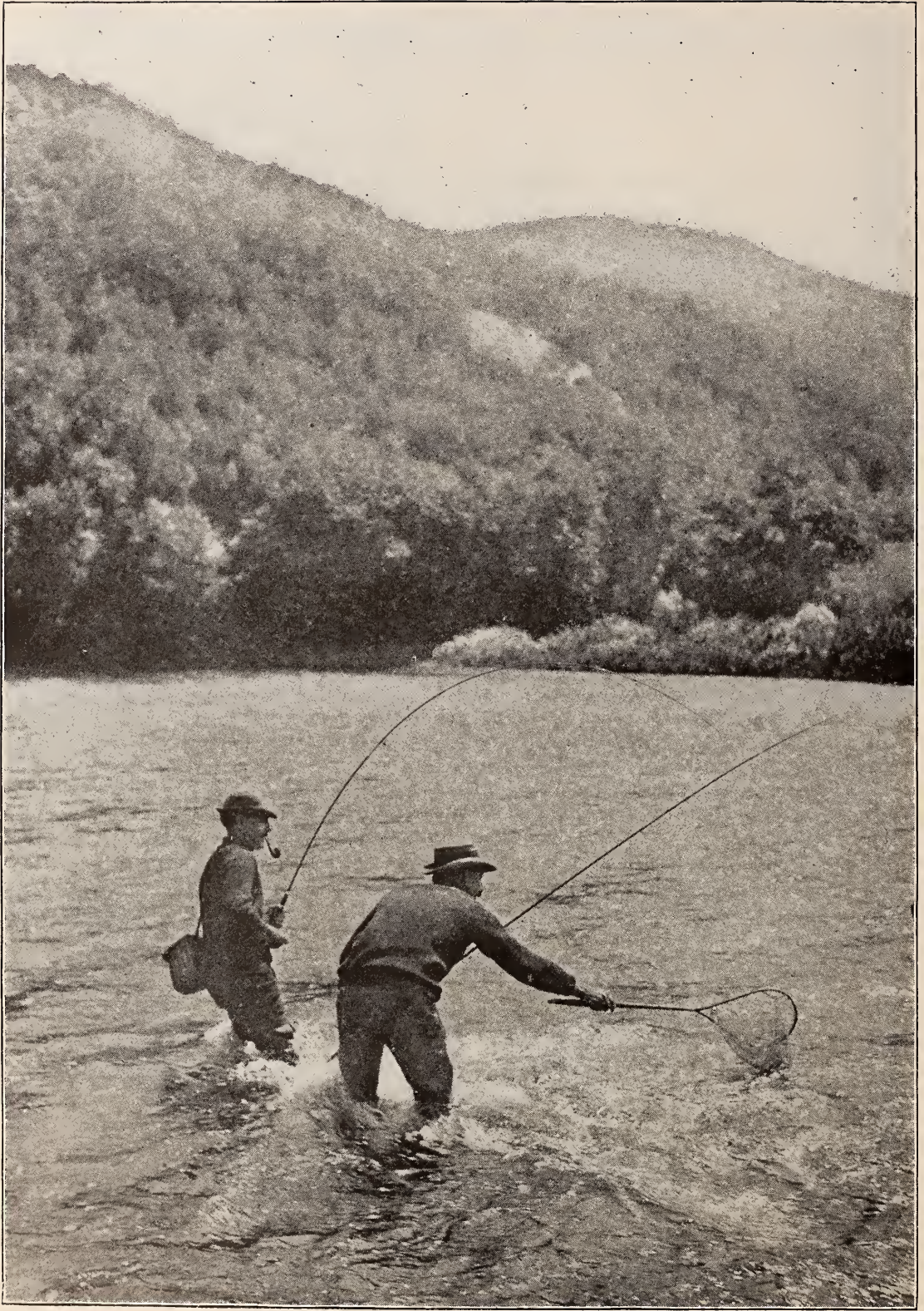

AN ANXIOUS MOMENT.

One of the 37th Prize Winners in RECREATION'S 7th Annual Photo Competition.



A HUNTER'S OUTFIT IN THE ROCKIES.

One of the 37th Prize Winners in RECREATION'S 7th Annual Photo Competition.

---



AROUND THE CAMP FIRE.

One of the 37th Prize Winners in RECREATION'S 7th Annual Photo Competition.

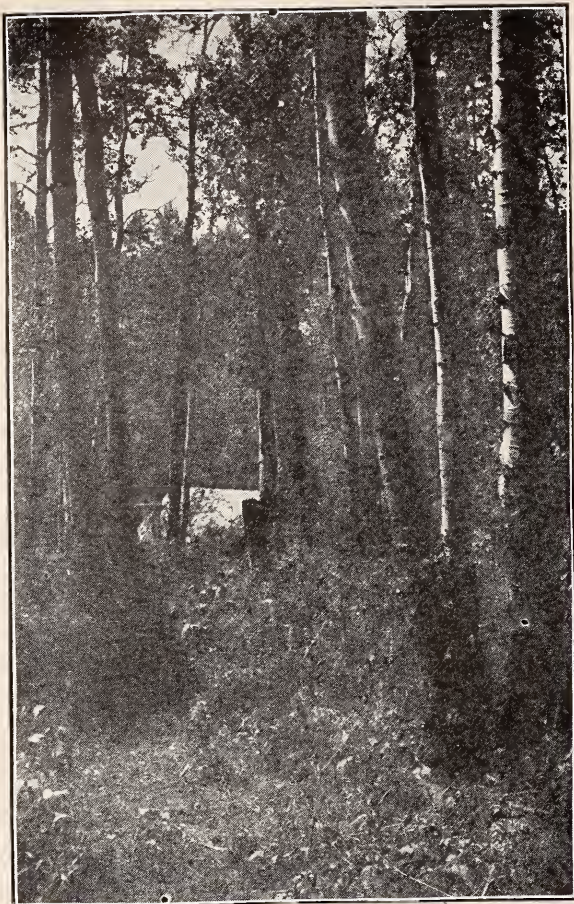

THE CAMP OF THE ASPENS.

One of the 37th Prize Winners in RECREATION'S 7th Annual Photo Competition.

### DON'T WANT TH' PRESIDENT'S PLACE.

FREDERICK GOSHORN.

Dad's often said ef I was good,  
 An' worked and studied jest ez hard  
 Ez ever anybody could,  
 Thet nothin' never could retard  
 Me bein' President some day;  
 But I'll be dinged ef I don't wish  
 He'd stop a-talkin' thet erway!  
 Fer I would ruther set an' fish  
 Down on th' wharf boat, like ole John,  
 An' spit terbaccer juice and cuss,  
 Then listen to Dad goin' on  
 'Bout bein' President or wuss.

Dodrat it all! I'd ruther be  
 Jest like ole nigger Bill; ez mean  
 An' dirty an' ez black ez he,  
 Then bein' all drest up an' clean;  
 Fer then a feller wouldn't hear,  
 "Put down thet pup this minit!" an'  
 "Don't touch thet stove pipe, Willie, dear;"  
 An' "Will, set down an' be er man."  
 Id ruther have er boat an hook  
 An' line an' sure 'nough canvas tent  
 Then be wrote in th' his'try-book  
 Ez bein' ther greatest President!



AMATEUR PHOTOS BY THOS. A. MORGAN.

### CURIOSITY.

One of the 37th Prize Winners in RECREATION'S 7th Annual Photo Competition.

I like ter set there on th' boat  
 An' watch th' waggins come an' go,  
 An' see th' steamboats by me float,  
 An' hear their far off whistles blow!  
 I like ter jerk th' bluecats out,  
 An' sometimes ketch er mudcat, too,  
 An' see th' suckers swim erbout  
 An' bite fer nothin' else to do!  
 I'd like ter set there all th' time  
 An' feel ther sunshine in my face—  
 I tell yer what, it's mighty fine!  
 An' I don't want no President's place.



## THE TRAVELS OF A HUNTING KNIFE.

DR. A. J. WOODCOCK.

October, 1888, was an ideal month for the sportsman in the lake region of Northern Wisconsin. I was stopping in Minocqua and passed most of my time on the Juliette, a beautiful steam launch, as the guest of her captain, S. W. Ray, a good hunter, a dead shot, and a pleasant companion. Our favorite cruising ground was East Kanaquesaque and Big Tomahawk lakes. One morning the captain had a load of freight to run over to the head of Big Tomahawk, and a hunting party and 2 canoes to take across the East lake to where the thoroughfare comes in from the Arbor Vitae chain.

About a week later we made the same trip with the outfit of a land hunter. On our return we had passed the Arbor Vitae thoroughfare when 2 signal shots rang out over the lake. We lay to and answered the signal. Presently 2 canoes appeared, containing, as it proved, the same hunting party we had towed out the week before. Joe Ross, the leader of the party was the handsome, herculean son of a Wisconsin pioneer. His partner, Uncle Johnny Smith, was a short, grizzled veteran of the camp, canoe and trail. These old-timers, in season, annually ranged the forest in some part of the Northern wilderness. That year they had induced the lumber merchant of their town to accompany them. He was a good fellow, but unused to the ways of the woods. They were all hungry and quickly disposed of the remains of our lunch, after which Uncle Jimmy told us the following story:

"After you cast us off, Cap, we made a good run up to our old camp ground, for Joe and I have packed and paddled our way into these yere woods a heap o' times afore the blasted railroad filled 'em with green-horns. We showed our new pard here how to make a woodland cooking range out of green hemlock logs, and build a framework for our waterproof wickiup cloth. Joe ketched him some bait and showed him whar to fish, and told him to finish the camp, pick plenty of hemlock browse off the trees we had felled for the fire and make the bed 'fore he went to fishin'.

"Well, we lit out for the old runways that we knowed so well. A good many years ago the Chippeways built a wattled brush fence, that run V-like for miles with gaps for the deer to pass. Every once in a while the Injuns would make a drive, and then, you bet, the deer ketched it. Joe and I got onto their game and have worked

it a many a time since. We soon found that the woods had been beat up all summer, the deer badly skeered and a good deal of the old fence burnt up.

"We didn't get no deer and when we got back to camp everything looked all right except the fire. It was putting up a heavy smoke and givin' out mighty little heat. I grabbed an axe and soon had a green hemlock fire and supper ready. It was a cold night and I made a small fire in the wickiup, mostly coals that I carried in.

"We turned in and didn't know nuthin' for no one knows how long, when all to once the 3 of us waked up a burnin', an' a chokin', an' a cussin', an rolled and tumbled into the open air. Our new pardner here had made our bed outen the dry hemlock browse that the fishin' towerists had used last summer. Fat pine couldn't a'ketched quicker or acted wusser. We was bad burned 'fore we sensed what was the matter and got out of the wickiup.

"Joe an' I grabbed ahold of the burning tent cover and yanked off what was left of it. We then jumped into the blazing bedding, kicked it out of the fire and rolled and stamped the flames out. Turning to the feller that hed been entertainin' of us, turrible cam like, Joe said, 'Whar is thet ammunition?'

"'I don't know,' says he; 'it wus under the bed.'

"'Back, boys,' cried Joe, 'back for your lives.' An' you bet we slid.

"Joe jumped the wrong way; he landed right in the burning browse, raked up the ammunition boxes an' flung 'em clean away. 'Bout all we saved was the ammunition an' our guns. We toughed it out fer a week, but I tell you, Cap'n, it's a puttering time we've had of it. If ther'd been any deer round yere, we'd stayed; but bein' as there ain't we're going down the road a piece and go in where the kentry ain't beat up so, an' our new pard, he's a goin' home to send us a new outfit."

Soot blackened and with clothing burned full of holes, truly they looked as if they had been having "a puttering time." The end of Uncle Jimmy's story found us at the wharf. We went up to the hotel and our new friends retired to their rooms.

Never before was the difference that clothes make in a man so forcibly brought home to me as when the hunting party came down to supper. The lumber merchant was in his natural element. He not only shone, but showed that he felt it, and celebrated his escape from the woods with

many a bumper of what I have heard a Potawatommie Indian call "skittawaboo." Supper dispatched, the evening slipped by in pleasant converse with the habitués of the place around a roaring log fire. The new partner reached the confidential stage of his potations, and linking his arm within mine he drew me to the farther corner of the bar in front of the building and said:

"You-hic-may think 'cause us fellers didn't kill any deer that we don't know how. 'At's all ri', but jus' same we kill more deer than any other fellers 'at goes into these woods. You shaw them gun-gunny zacks? Well, we got some cut down Winches'er's in 'em."

At that point I interrupted him, for I noticed that one of the guides was straining his ears to make out our conversation, so I promptly led the lumberman into the open air.

We retired early, as the captain had a load of freight to run over to the head of the Big Tomahawk lake in the morning. The sun had barely swung above the sea of pines when Captain Ray had steam up on the launch, and I was casting her off from the wharf. A hail from the bluff back of the landing arrested us, and Joe came running to the boat. "Hold on, Doctor," he cried. "I want to see you."

Loosening the light strap that held his hunting knife to his side he buckled it about my waist and said:

"I want to give you something to remember me by as long as you live. This knife once belonged to a Norwegian from Trondhjem. Many years ago he pawned it for a pint of whiskey at a lumber camp in these woods and never redeemed it. It was my father's knife and I have carried it for years. With it I have drawn every kind of game that roams these forests. Good bye, Doctor. May prosperity follow your trail."

The knife was a lovely creation of boxwood, coin silver and Skania silver steel. The finely carved boxwood handle was  $3\frac{1}{2}$  inches long; the blade,  $3\frac{1}{4}$  inches; and the exquisitely modeled and carved sheath of boxwood,  $5\frac{1}{2}$  inches. The wood scabbard took in rather more than one-third of the rounded knife handle, which was fullest in the middle and tapered evenly to each end. It was an admirable arrangement, and absolutely prevented the slipping of the knife out of its sheath. Many are the knives and surgical instruments I have owned, but never have I had a tool that held its edge under hard usage as long as that old Norsk knife.

One morning in January, 1895, the good sloop Tease lay at anchor off Punta Rassa. Entering her dingey I was soon set aboard; the anchor was weighed, sails hoisted, and the Tease shot rapidly South along the Florida main.

At last the pleasant lines of our destination, Mound Key, came in sight, and soon the Tease was anchored in a little cove on the North shore of the island. Lying in the center of the great Bay of Estero, this fertile key comprises some 80 acres of black soil, and is elevated about 80 feet above the bay. Under giant gum-limbo trees on this, the highest land in all South Florida, was the board palace of my Cracker host. A week slipped quickly by, during which I repeatedly visited the sea fowl rookeries, the oyster beds in the tide-water creeks, the best fishing points in the great bay, hunted quails and turkeys on the main and thoroughly explored Mound Key.

One evening the young sons of Captain Johnson, Herb and Willie, begged me to take them hunting on the mainland. Their mother said, "Do take 'em, Doctor, and stretch their legs for 'em. Pore little fellers, they be so cramped like on this here key."

"Certainly," I replied, "it will give me great pleasure to have them go. I will take the 45 rifle, Willie can take my fishing rod and Herb the 22 rifle. When Herb found that his ears had not deceived him, he clasped the little gun to his heart, snuggled his face down upon the shining barrel and said, "Doctor, I love her. Her is a dandy. Her'll kill a robin to-morrow sure." To the little Crackers of South Florida, robin means anything that wears feathers.

Sunrise found us sailing up the bay with Captain Johnson who was on his way to Punta Rassa, with the boys' light skiff towing astern of the Tease. When off the mouth of Spring creek we entered the skiff. Herb handed me a paddle and shipping a pair of light sculls sent the boat dancing over the bay toward the mainland. As he pulled for the mouth of the creek, I could but notice the sad deformity of his left hand and wrist, and on asking him how it happened he told me the following tale:

"Me and Willie was fishin' more'n a year ago off of that point over there. We got tired and laid down in the boat and just let her drift. Finally I set up with my back against the seat and my left hand and arm hanging over the side of the boat. All at once a big shark seized my hand and wrist in his mouth. I screeched and held on to the side of the skiff and Willie, he screeched, he did, and held on to me. It scared the shark, I guess, 'cause he let go of my arm. It hurted me awful and made me sick. Willie took me home and Pap went after one of the Kresh'yuns right off. He came and fixed my hand and wrist and after a long time I got well. Pap says them Kresh'yuns is queer like, but they was awful good to me when I was hurt. Say, Doctor, be there many queer people like

them Kresh'yuns up where the sick Yanks come from?"

"No lad," I said, "you have them all down here."

"Well," he continued, "they pretty nigh starved at first. Mam said they would a starved if Pap hadn't a showed 'em where and how to fish and truck. They understand the country better now, so Pap says, and helps to fill it up like, though they is a queer kind of settlers, and Mam says there's shore no harm in them."

About a year before the time of which I am writing Dr. Tead and his Careshians had emigrated from Chicago and other headquarters in Michigan, gone down into Florida and settled on the coast South of Fort Myers. Their main settlement was on the site of an old plantation 5 or 6 miles distant from the coast on Spring creek. They held all property in common and believed that perfection and all the attributes of Deity were attainable in the flesh. Dr. Tead, whom they called Master, had taken abundant resources with him into their new home.

The tide was ebbing fast and we encountered a stiff current on entering the creek. We stopped at the first oyster bed and regularly filled up, after which we went on to some fishing grounds where the creek formed a series of deep holes. Herb and I helped Willie catch a can full of fiddler crabs for bait and leaving him to fish started North on a strip of sand that had once been the shore of the bay.

The only life we saw was the ever present turkey buzzard, the valued scavenger of the South, and several pairs of Washington eagles wheeling above the pine trees. The morning proved a blank to us as far as game was concerned, though we did start a deer. On our return we made a detour and came to a great pine tree with an eagle's nest in its top. The nest, which was built of sticks and rubbish, was larger than a bushel basket and had a young eagle in it. He was almost black in color and was evidently still under his mother's care. We sat down under the tree and ate our lunch, meanwhile watching the eagle. I wanted a specimen but knew that if I shot the youngster he would fall back into the nest where I could not get him.

Presently one of the old eagles returned and wheeled in great circles above the giant pine, too far for a rifle bullet to be certain. I wanted a specimen, however, and so just as the ivory bead of the front sight cleared the body of the eagle, I drew the trigger. For an instant there was a great commotion, but the bird, winded by the ball, had only lost its balance. Just then came the thud of a body striking the ground, and the carcass

of a bluebill duck, neatly sheared of its feathers so as not to obstruct the flight of the eagle, lay within 3 rods of me.

The eagle then plainly showed its anger and excitement and flew in descending spirals above the nest. I much wished to see this prince of the air regain its lost quarry, which I believe it was about to do, but fearing that in its anger it might strike the boy, I covered it with my rifle and again drew the trigger. That time the bullet found its billet.

On returning to the boat we found the flood tide just beginning to run into the creek. Herb said we could drop down to the oyster beds but would have to wait there until the tide was high enough to float the skiff over the bar. Willie had the bottom of the boat covered with sheepshead, bass, catfish and jackfish, but like all anglers he wanted just one more, so he trolled in the deep holes as we passed them. Getting snagged, he lost the Hamilton spoon he was using. Herb grounded the boat on a sand bar and asked me to blaze a mangrove on the bank so he could return to the place and get the spoon sometime when the tide was out. After making the blaze I did not fasten my hunting knife to my belt as I should have done but thrust it into my hip pocket. As I was about to take my place in the boat Herb pointed to a track in the sand and said: "That's a Kresh'yun's track. There are some of them below us on the creek." I asked him how he could tell their tracks from others.

He replied: "Easy enough. They are the only Yanks around here. Just look at that track, Doctor. See how that feller punched his heels right down into the sand. You'll never ketch Pap a-walkin' turkey in the sand like that; it's too hard work. He puts his weight on his toes and the ball of his foot when he walks."

Taking our places in the boat we were soon as near the mouth of the creek as the stage of the tide would permit. I had just tied the skiff to a mangrove to prevent its floating off up' the creek with the tide, when Herb, who was standing on the bank, yelled at me, forgetting his verbs as was his wont when excited, "O! Doctor, there they'uns. There the Kresh'yuns. There Doctor Tead." Looking down the creek I saw some 15 or 20 men clad only in their shirts, with spades in their hands and the Florida sun reaching affectionately after the calves of their legs. They were digging a ditch to straighten the channel of the creek. Stepping into the slowly rising tide, against which my Thompson boots were proof, I walked up to the man whom the laboring band of Careshians called Master.

Doctor Tead was a man on the shady side of 50, with blue eyes and light brown hair well tinged with gray. He was of medium height and well built. He wore a white helmet hat, gold eyeglasses, faultlessly white shirt, collar and cuffs, with a neat white tie; aside from that he was as naked as the day he was born. When he learned that I had come neither to laugh nor scoff at him he unbent and we passed an hour in pleasant conversation as we marched up and down the sands of that tide-water creek.

At last, when the rising tide had nearly reached the tops of my boots, the boys came with the skiff. Seating myself in the stern and turning to the master of the Careshians, I asked him if he had some lime water in his supplies? He replied

that he had, whereon I told him to mix it half and half with any oil or grease and that the product would be carron oil.

"*Cui bono,*" said he?

"Well, Doctor," I replied, "you and your men are the worst sunburned lot of fly-up-the-creeks in the old cracker State to-day, and the carron oil will quench the fire that has already begun to burn in the calves of your legs. Good-bye, Doctor, and good luck to you."

When we were fairly under way I thought I would clean some fish for supper. Putting my hand in my pocket I found my hunting knife was gone. While I was walking up and down the estuary with Doctor Tead, the old Norsk knife had worked out of my pocket and to-day lies beneath the glistening tide of Estero.

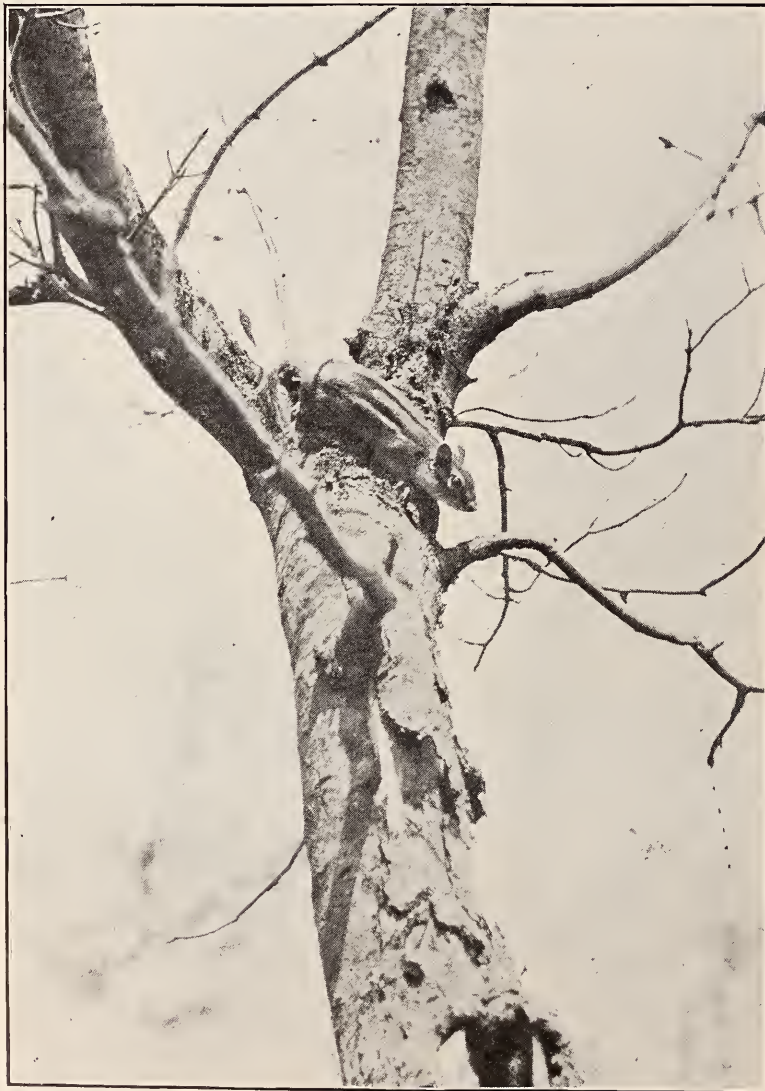

AMATEUR PHOTO BY B. H. BEEBE,

#### CHIPMUNK

One of the 18th Prize Winners in RECREATION'S 7th Annual Photo Competition.

## A MORNING'S DUCK SHOOTING.

H. W. CLOSS.

One morning in the fall of '96 found my friend, F—, and me walking toward the big buckwheat flats a few miles Southeast of the village of R—, in Northern New York. It was not yet daybreak, the air was cold and a stiff breeze was blowing.

Arriving at our destination, we ensconced ourselves in our hastily constructed bough house. Seated on a rough board supported by pieces of rails, we waited, listening to the ululant solos of a belated owl and the chorus of innumerable frogs from a neighboring marsh. Gray streaks began to show over the hilltops in the East, and the morning broke cold,

some inexplicable reason, they wheeled and came down the wind, passing over about 30 yards to our right. We extended to them a pressing invitation to stop, which 3 found it convenient to accept. As we retrieved them we saw the rest winging their way over a hill half a mile distant. We followed them, knowing as well as they of the little stream which wends along the other side of that hill. But how to reach them unobserved was not so well known to us.

After consultation we decided to climb the hill and crawl over its brow to another old rail fence, which ran nearly to the



SUDDENLY WITH A DISCORDANT CRY THEY AROSE, STARTING DIRECTLY AWAY FROM US.

cloudy and damp. In the merging of darkness into light we began to recognize objects around us in their true character. Looking about, we saw a flock of 10 or 12 ducks quietly feeding in the middle of an adjoining lot.

"We'll have to crawl along the fence and take big chances," said F—, knocking the ashes out of his pipe and changing the shells in his gun.

So concealing our bodies as best we could, we crawled along the old rail fence to a point about 75 yards from the flock. Suddenly, with a discordant cry, they rose, starting directly away from us. Then, for

stream at its widest point. There we expected to find the remainder of the flock. We climbed the hill, crawled to the fence and scanned the creek. No ducks could we see, but we could hear and knew they were not far away. As we were about to approach nearer I saw in the distance a living V coming toward us. Down we dropped as flat as turtles.

"Don't you think they have seen our friends in the creek and are going to join them?" I ventured to ask.

But F— was too intent on watching the birds to answer. Presently the newcomers paused in midair, and then dropped

into the stream. There was much diving, quacking and splashing of water. We could see them then, and were interested on-lookers for a few moments, until the twitching of our trigger fingers could no longer be disregarded. We wormed our way down the hill while the noise of flapping wings and splashing water increased momentarily.

We got within 20 yards of them, and were then suddenly perceived. The alarm

was given, and simultaneously they arose from the water. When about 25 yards up they bunched beautifully. We poured the contents of 4 barrels into them and had the satisfaction of seeing 5 well fed black fellows come toppling down, all cleanly killed, but one. He was merely winged, and gave us a blood warming chase which we hugely enjoyed. Gathering up our ducks we turned our faces homeward.

## WHEN THE FROST IS ON THE PUMPKIN.

A. N. KILLGORE.

Up 'fore daylight, afield at six,  
 Me an' my gun an' a snack t' eat.  
 With th' sun peepin' foxylike over th'  
 hill,  
 An' th' night frost powdery under my  
 feet.  
 Rooster 's crowin' way over yon',  
 Houn' dog 's givin' th' rabbits a jolt,  
 Air smells ez sweet ez a basket o'  
 chips;  
 Makes me jes' feel like a two year ol'  
 colt.

Over th' worm fence an' through th'  
 field,  
 Down t' th' crick, consarn the luck!  
 Must be gittin' ez blin' ez a owl—  
 Shot at a rabbit an' killed a chuck.  
 Climb up th' ridge an' set down t' res',  
 Lawze, but wa'nt them catbriers  
 thick.  
 Kin hear th' hungry ol' sawmill down  
 there  
 Eatin' up hemlock a foot at a lick.

Chipmunk's runnin' along th' stone wall,  
 Squirrel's sassin' me likely ez not,  
 I seen that rabbit, but dad burn my hide,  
 Th' mornin' 's too peaceful t' bust with  
 a shot.  
 When I kin stand on a hill like this,  
 An' look on th' valley all speckled an'  
 brown,  
 Seems sort o' curi'us 'at a good many  
 folks  
 Don't live in th' country 'stead o' th'  
 town.

You fellers kin lay in your ol' feather  
 beds,  
 'Til th' sun melts th' frost all off th'  
 grass;  
 But lemme git out when th' air's feelin'  
 cool,  
 'Cause I like t' breathe it 'fore common  
 folks has.  
 Jes' give me a gun an' 'n airly start,  
 A handful o' grub an' a ca'tridge 'r two,  
 A mornin' gray an' 'n air that's sharp,  
 'N I wouldn't swap places with any o'  
 you.

First Katydid: Why didn't you come before?

Second Katydid: Were you calling?

Was I calling? Don't you see how hoarse my legs are?—Exchange.

## GABE BEAR'S BACCY.

THEODORE ROBERTS.

Though the Maliseet Indian of the River St. John has, to outward appearances, fallen from his high estate, beneath his dusky skin still flows the warrior blood of his ancestors. To-day he farms a little and nets salmon in season; makes bark canoes, snowshoes, and paddles of bird's-eye maple; does some trapping on the upper waters, and guides sportsmen into the wilderness after moose and caribou. He wears the cast off clothes and broken hats of the white man, and his squaw makes baskets of ash splints, trimming them with strands of sweet hay.

Though his code of honor is strict in many ways, the man who will risk his life for you, facing the wounded bull moose or breasting the rapid, will pocket your tobacco pouch without a moment's hesitation.

Across the river from the elm-shaded, peace-girded capital town lies an Indian village, a cluster of weather-beaten cabins by the water side. There dwell the braves and their families who traffic and beg in the town. They are a flat faced, bow legged people, these suburban Maliseets. They build fine canoes for sale, but the craft they use themselves are patched, twisted and stained. During summer they spend much time on the water, catching driftwood, and searching for sweet hay, ash, birch bark and willow. Their journeyings seldom take them farther down the river than Gagetown or higher than Savage island. The Nashwaak and Nashwaksis know the soft dip of their paddles, and in spring, when the muskrats are about the thumping reports of their shot guns.

About 15 miles farther up the river stands an Indian village of a different stamp. There are found snug little intervalle farms, self respecting canoes, a few "breeds" with French blood in their veins, stalwart Maliseets, a good priest, and a neat chapel. It is called French Village.

But the red man is everywhere along the valley of the St. John, at Oromocto, at Gagetown and along the Tobique and her sister streams. Soft footed, stolid faced and dirty, the lord of the wilderness steals his white brother's trousers and tobacco, and goes about his humble occupations with a grumble, awaiting in sleepy content the return of Gluskap.

Gabe Bear was cousin to Jim Paul, the chief at French Village. He lived in a small cabin with red door and window frames, just out of reach of the spring freshets. He never had to shave, for in his youth he had, according to the cus-

tom of his race, destroyed a budding beard by pulling out the hairs one by one. His cousin's eldest son, who had worked a year in a sawmill, bought himself a shaving mug and a razor, and though Gabe was dazzled by the red, blue and gold design on the mug, he scorned the whole outfit.

"What for all this tomfool?" he said to his nephew. "You ain't no big white man; you common Injun with patch behind!"

In private he confessed that the razor might make a good knife; but why a young man should scrape his face with it and with no apparent result was more than he could see. Once or twice he borrowed it to cut his tobacco with. The owner did not object; to him a razor was a razor, be it sharp or dull; but when Gabe skinned 3 muskrats with it the youth threw it away in disgust and returned to the sawmill.

Gabe did not believe in working hard all the year round. He held that a man with eyes and hands bent always on accomplishing something misses half of life. The life of the river was the life for him. If he poled and paddled against stiff water sometimes, he could forget it when evening fell, remembering only the easy water, the cool shade, and the songs of the birds. If he spent 3 weeks on the Tobique with a sportsman from the city he took a long rest afterward, lying on the clover bank beside his cottage and listening to the bees and the untroubled river. When his tobacco was gone and no more could be borrowed from his cousin, the chief he would carry his canoe to the river and slip down a few miles and across to Crock's Point.

Gray and dry lay the beaches under the midsummer sun. In a landlocked pool swam young sturgeon that had been taken from the salmon nets. Pennyroyal and narrow bladed grasses shot up between the hot pebbles. An old red dugout swung in the shallow, amber water. Back of the beach loomed giant willows, with trees of choke cherry and bass wood in their shade, and at the top of the steep bank one might catch a glimpse of outbuildings and apple trees. Gabe crossed the beach and went up the path between the rank growths of snapdragon and milkweed. At the top of the path he reached a little clearing, bordered right and left with cherry trees. Below the right hand bank lay an intervalle meadow, ready for the cutting. The sun spun a sleepy haze above the ripe grasses.

A mowing machine sang like a giant cicada somewhere in the distance. Gabe made his way to the long open porch of the farm-

house, and seating himself on the edge of a bench, produced his pipe. It was black and short, and, worse still, empty. The mistress of the house came out of the kitchen.

"Well, Gabe, what do you want?" she asked.

"Good mornin'. You seem in big hurry," replied Gabe.

"I have my work to do," said the woman, "and so should you."

Gabe smiled. "Me work hard. Tree week take Big John way up Tokik. Pole um up miles. Push um through rapid, tote um round! Near bust. Big John, he weigh 2 tun an' sit in canoe all day an' fish an' smoke. That hard work, ugh?"

"What are you doing now?" she demanded.

"Takin' little rest," replied Gabe, "but no 'baccy to smoke."

With her sharp grey eyes the mistress stared at the impetuous brave in a way that would have killed an ordinary mortal. Gabe looked at the woodpile and grunted. He had been stared at before. He had been lectured, scolded and even threatened with a mop handle, but the tobacco had always turned up.

"Me go help Jim cut hay," he said at last.

The woman laughed.

"Why, he wouldn't have you in the field," she retorted.

She retired into the kitchen, and soon came out with a plug of black tobacco. Gabe accepted it with a silent smile, and immediately set about filling his pipe. The mistress stood before him, her hands on her hips, trying to look as if she did not enjoy the sight of Gabe enjoying himself. It took him a long time to find his matches. At last he rolled a thin blue cloud into the air and sniffed critically.

"Not like 'baccy John an' me smoke up Tokik," he said.

"It's good enough for you, you lazy critter," replied the woman; "so now go away, and the next time you come be sure to bring me a basket."

Gabe left his seat with a weary sigh and passed out into the sunlight. At the top of the bank he met Jim Hollis, the owner of the farm.

"Hullo, Gabe," said the farmer, heartily, "how are you?"

"Good," said Gabe. Then, with a grave face, he produced the tobacco.

"Your squaw, he give me this," he continued, "an' he call me dam bad names, jus' like always." Hollis laughed.

"My squaw is a good woman, Gabe, and you should hear what she calls me sometimes," he said. Then he passed on to rig up the mowing machine.

Before Gabe had gone half way down the path his quick eye noted the absence of his canoe. He sprang on to the beach and looked toward the thoroughfare which races between the island and the mainland. There was the canoe drawing steadily down to the swift water, broadside on; and over the gunwale he saw the smiling faces of Jim Hollis' 5-year-old twins. It was the work of but a few seconds for the Maliseet to cross the shingle, snatch up a spruce pole and push the dugout into the current. His dark eyes burned with the joy of action and the chase. The dugout swam like a hemlock log, so weary had it grown of sun and rain, spring, summer and winter. Gabe put his whole skill and strength into it, surging on the pole until the sullen old craft darted like a fish. The shallow waters of the thoroughfare laughed and rattled over the pebbles. The canoe ahead rushed down toward the deeper places, toward the black pools under the willows, where sticks of submerged driftwood swing in the amber shadows like evil monsters. The children, feeling the awe of the deeper water, began to cry. In their fear they crowded together toward one side of the canoe and turned it over. Gabe had brought the dugout along the island shore, where bottom could be found for the pole, and when the lighter craft turned over he ran forward and jumped toward mid-stream. After half a minute's hard work he landed on a spit of sand with the speechless, water-logged twins. There he left them, and ran along the shore to where the canoe, bottom up, swung uncertainly in an eddy.

It was dinner time at the farm when Gabe appeared in the kitchen, leading the crestfallen twins. He had lost his hat and his black hair hung in wet wisps across his forehead. A freckled kitchen girl, who was dishing potatoes at the moment of their entrance, screamed, and let everything fall to the floor. The mistress of the house rushed in.

"What's the matter?" she cried.

"Your papooses steal my canoe," said Gabe, "an' then turn over. Me pick um up, git all wet and spoil 'baccy."

He grunted and turned toward the door.

"You mean that you saved the little beggars from drowning," said Jim Hollis, who had followed his wife from the dinner table.

"Yes," replied Gabe. "Lazy white squaw can't take care own papooses, so ole Gabe he do it, ugh!"

With this parting shot he left the house, but smiled as he went down the path, for he knew that in future, tobacco would be his without the asking.





THE CONSPIRATORS.

One of the 36th Prize Winners in RECREATION'S 7th Annual Photo Competition.



AMATEUR PHOTOS BY D. W. FLINT.

RIGHT ON TIME.

One of the 36th Prize Winners in RECREATION'S 7th Annual Photo Competition.



ON HE CAME AND WITH A FLOP, FLOP, HE LANDED IN THE STUBBLE.

## GOOSE SHOOTING IN MANITOBA.

H. M. LAING.

When the autumn frosts have dispelled summer and brought mellow and invigorating days, where is the sportsman who does not begin to fidget and to cast longing eyes toward the scenes of his former exploits, or, if caged within the town, to have day dreams in which he vividly pictures once more the details of some by-gone hunt dear to his heart? How small, indeed, would be the pleasure derived from the hunt if such gratification ended with the quarry bagged! To the true sportsman this is the least part of his joy. It is the opportunity opened for those delightful ruminations; to live over again, through long winter evenings, past experiences; for those confidential chats with brother sportsmen who have shared the same vexations and joys afield; and to rehabilitate and freshen those interviews with nature itself. Perhaps the duck and grouse seasons come and hurry by with little impression on his assumed stoicism; but wait till the gray geese return from the North and get their music going, night and morning, as the old ganders lead their lines to the fields! Then see him cast business to the winds, spend an hour or 2 in oiling and fondling his trusty double barrel, and then go off for "a day with the geese!" Where is the sportsman who can withstand the invitation of that bird of game birds!

The geese commence to congregate on our prairies about September and stay until the freeze in November. The essentials of a good goose-shooting locality are open prairies and proximity to lakes and sloughs. Owing to perpetual molestation during the fall the birds become wary and shun the scrubby country, keeping to the open, where it is a grand sight to see them in the mornings and evenings, going to and from their feeding grounds. Immunity from pursuit, when they can secure it, shows them regular in their habits. They select some particular locality for feeding ground and thither they go on frosty mornings punctually with the sun's rising; but on warm or windy mornings at daybreak and frequently before it. These birds have, without doubt, a system of command among them; for in their flight they move in small detachments, each under the direction and leadership of a wise old gander, who preserves strict discipline. When not disturbed or alarmed they settle, flock by flock, on their chosen field, and, while their sentries keep unremitting watch and ward, the remainder of the flock gabble and gobble until 9 or 10 o'clock a. m., when the

return flight takes place, generally in less systematic order. About 3 or 4 o'clock they return as in the morning and leave at dusk or dark. For a night roost geese joy in a sandy beach or bar, or a bit of bank projecting far out into the water.

So highly is the gray goose prized as a game bird that many and various methods are resorted to by sportsmen for his undoing. Of stalking, running or driving with a horse, decoying on land and in the water and flight shooting to and from the feeding grounds, the 2 latter methods are most commonly adopted as being the most successful and sportsmanlike. Happily, few geese are now killed by stalking, on account of their wildness and watchfulness; but formerly, when they were more numerous and less wary, hunters frequently approached a feeding flock by keeping concealed behind a horse, and often secured half a dozen birds by a ground shot at close quarters. Running the flock with a horse is a practice which some shooters resort to, but it requires several men, is a trifle risky for the horse, and none too satisfactory. It would be useless pursuit but for the fact that geese will almost never rise from the ground and fly either directly with or against the wind. They tack off against it on an angle depending on the strength of the wind. When a flock is chosen the hunters slip from the rig and lie concealed on the ground, some distance apart, forming a line in the direction the geese will take after rising. Then the teamster circles around the birds, and, approaching quietly, until they take wing, dashes at them from the side and often directs them over the line of fire. While the horse or team is running full speed over the prairie or field a badger-hole may prove disastrous to horse or buggy; but such is the usual spice of danger.

In flight shooting, as the birds leave the water the hunter must get the line and direction of flight taken by the first flock; and it is remarkable how the succeeding flocks will, one after another, follow that same course. The same is true of the return flights.

In decoy shooting on the fields different sportsmen employ different means. The decoys used are generally sheet iron, cut and painted to the nearest resemblance of a goose; but it is better still to have partially domesticated live wild geese tethered. These may be secured from some nesting place before or after hatching and with care be raised with the barnyard fowls. The shoot-

er using decoys usually conceals himself in a pit; but where such can not be dug, fair results may be obtained by lying flat on the ground, concealed by the grass or stubble. The disadvantages of this are that the shooter can not see an approaching flock well and that he loses time in springing from the ground and getting into firing position.

Old sportsmen say the geese are getting more difficult to decoy year by year, and the reason is apparent. The artificial geese, then, must be put in as natural an array as possible to outwit the suspicious old ganders. A number of the decoys should have movable heads, to be lowered as if feeding; and on no account should they be all facing in one direction, or have all their heads erect, as that implies watchfulness and danger. As a rule, the more decoys the better; for the reason that a large flock seldom swings into a small one, while small flocks and single birds, or pairs, come without fear or misgiving to a larger group. The position of the pit and decoys depends considerably on the sort of day. On a calm day the shooter will do well to have his decoys scattered around the pit, as the birds are likely to come straight in from any direction without circling. If it is windy, the rule is that they swing in to the decoys against the wind, or, if they pass over them without becoming alarmed at the sudden disappearance of their counterfeit likenesses, which they rarely do, they will turn again and attempt to light against the wind. The better position on such days would be a few yards to leeward, especially when the birds are suspicious and discover the artifice. They would then still be within reach of the gunner before they swerve off; whereas a shot could not be obtained from the decoys.

Geese, with their great coat of feathers and plump bodies, are hard to kill, and numbers are wounded only to fly off and die perhaps a mile or 2 away, or often to reach the water. The lakes or sloughs in any locality subject to much shooting have always their numbers of helpless and dead birds washed ashore. Coyotes are fully aware of this fact, and the shore often shows unmistakable signs of a feast. On account of the vitality of such game the best goose gun is the closest and hardest shooter obtainable. The size of shot depends on the handling power of the gun, but it must be reasonably heavy to secure penetration. Goose shooting, to be successful, requires much time and patience, a knowledge of their habits, and not a little hardship, especially if the hunting is done late in the fall, just before the freeze; but there is something about the wild, free clamor of this great bird which speaks of unbounded liberty and brings up visions of

great Northern lakes, free from man's incursions; which quickens the blood on the coldest day, and lends fascination to the sport.

Can I forget my first goose! It was the latter part of September, and for a week I had watched the morning and evening flights; had seen large flocks settling time after time without disturbance on a certain field in the midst of many others; and I looked forward with unbounded impatience to Saturday, when we were to get closely acquainted. That day dawned clear, calm and frosty. As the first red tints appeared above the Eastern horizon I was up and, after an apology for breakfast, for I was too anxious to be hungry, I got my outfit and started. The outfit consisted of 10 decoys, home-made and rather doubtful looking, which were wrapped in a bag and carried by a string from my shoulder; a lunch and a borrowed double gun, said by the owner to have been a good one in its day. Reaching my destination, after a 2 mile walk, just as good daylight came in, I chose a patch of the thickest and longest stubble, put out my decoys and prepared to lie down in the dead furrow. One trial convinced me that rough, frozen ground has angles and corners. To make myself more comfortable, I started to get some straw; but just then such a goose clatter arose from the lake, about a mile distant, that I scampered back to the decoys, and frozen ground was forgotten for the time. The squawking became incessant. I flattened out on the ground, hugged my gun and waited; but not a goose appeared. Soon the sun peeped, then climbed up full height; and immediately I heard the squawking of approaching honkers. I put an extra kink in my neck and strained my eyes in their sockets, for I was flat on my back. Yes, there they come, about a dozen, heading directly for my hiding place! Nearer! nearer! they approached. Suddenly, with a warning squawk from one old fellow, they all turned quickly aside and chuckled derisively as they went past, just out of gun shot.

Three more flocks came along, and each time the same performance was repeated. They had evidently had experience with decoys before. Then several small bunches came, passing close. I celebrated each visit by rolling to my feet, and emptying my gun, making much noise and smoke, but attaining no other result. This continued till my cartridge belt look slim. I concluded I was shooting at the birds when too far off. I resolved to wait longer the next time and call them if possible. But the flight was over and no more geese came.

As I was rising from the ground in despair, I heard a call, directly behind me, so down once more I went, and began

squalling the best imitation I knew. Yes, he was coming, and quickly, too! With a great effort, I held myself down, and determined not to move till he should come directly over me. Honk! Honk! Honk! On he came, the last ending in a squall right at my head; and with a flop, flop, he landed in the stubble. I could feel the swish of his wings. That was more than I could endure, and I sprang to my feet like a jack-in-the-box. Horrors! Both hammers down! Then as that thoroughly terrified goose was expending all his energy in putting space between himself and me, with wonderful success for such a heavy bird, I blazed away after him right and left. The shot rattled as it cut through his tough wing quills, and tore out some of his feathers; but although his legs hung, and his great black feet were spread out behind, showing how sorely he was hit, yet he kept tenaciously on, though quite unable to rise. I withdrew my eyes from him an instant to attend to a tight shell, and on looking again, lo! he was down.

For over an hour I searched the ground in the vicinity where he fell, but all to no purpose. By that time I had called myself all the hard names at my disposal, and had denounced the gun as a scattering old blunderbuss. I then picked up my luncheon, and leaving the field in possession of my decoys and a large number of empty shells, I went to the lake to spend the day.

The sun soon drove away all traces of the frost, and when I reached the lake it was calm and warm. The water lay like a mirror and without a ripple, except the track left by moving masses of geese, floating a quarter of a mile distant; or the swish of ducks as they alighted. Few of the latter were on the wing, but flock after flock, chiefly spoonbill, dotted the water close to shore, many with their heads tucked under their wings, enjoying the quiet and sunshine. From my seat on a boulder where I lunched, I watched numbers of whistlers, spoonbills and a few mallards, within a few yards, some disporting them-

selves, others asleep; but all utterly ignoring my presence. How I wished for my dog!

Taking a nap in the warm sunshine was a natural thing; and on waking, I found a coyote sitting a short distance away, enjoying the scenery, though I fancy I was the chief attraction. The roar of my gun wakened things considerably, especially the coyote. He covered a quarter of a mile at a swift pace. By 3 o'clock I was back in the field, waiting for more geese. In almost an hour a large flock came along, making a tremendous racket; but they described a complete circle around me, then left my vicinity altogether and settled on some plowed ground. Soon the flight began in earnest, and was as heavy as in the morning, but every flock took particular pains to avoid my decoys and me. The sun at length got low, and all hope of getting a goose had vanished, for hundreds of the birds were gabbling on all sides, when, without even a warning call, I beheld a dozen birds dropping down right before me. Now or never! I rose on my knees, and as the startled geese turned straight upward and bunched, I fired one barrel and then the other as quickly as I could pull. Fully expecting to see most of them come tumbling down, imagine my disgust to behold them all speeding away. The next moment saw me covering ground in the direction of that receding flock, at a pace to do credit to any sprinter; for one old honker was slowly but surely coming down, down, down, and at last struck stubble about a fifth of a mile distant. There was no escape that time, and in a few minutes I was up with him. How he hissed, and beat at me with the knobs on his huge wings! For a moment I felt sorry for him, and thought to take and keep him alive; but knowing he must be sorely wounded, I resolved that death was more humane, so he was "numbered with the slain." With a heavy game bag, but a light heart, I reached home shortly after dark.

---

First Specialist: Was the operation a success?

Second Specialist: Yes. The patient died solvent.—Life.

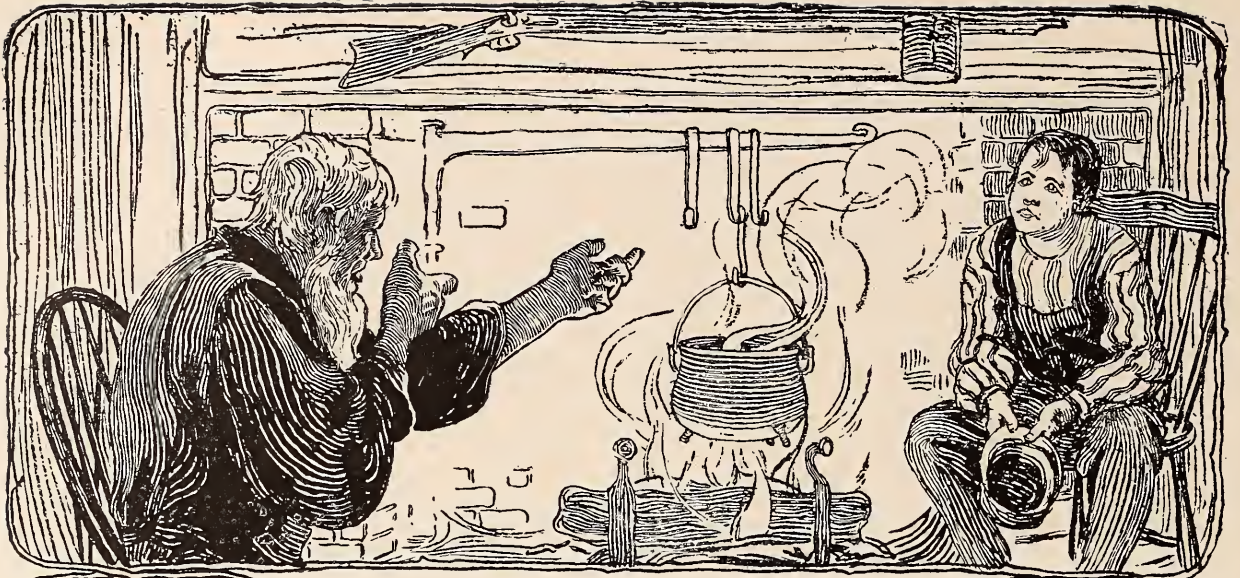

### GRANDDADDY'S OL' RIFLE.

J. B. ADAMS.

Thar she hangs, stranger. Jes' look her all over;

Not very purty, I'm free to confess;  
Battered an' scarred an' time-worn, but I  
love her

More 'n I love any human, I guess.  
Nearly six feet from patch box to muzzle,  
Lacked but an inch o' my granddaddy's  
height;

I've an id-ee 't'd consid'ably puzzle  
A now-a-days marksman to handle her  
right.

But long afore you saw the glimmer o' day  
She proved her efficiency many a way.

Often when I was a barefooted rooster,  
Back in the hills o' the ol' State o' York,  
Crouched in a nook by the fireplace I used  
ter

Listen to granddaddy tell of her work.  
Told o' the Injuns an' Johnny Bull tories,  
Told of his fights with the panther and  
bear,

Throwin' a thrillingness inter his stories  
Sich as would raise any country boy's  
hair;

An' often I've thought that fur courage an'  
vim

George Washin'ton wasn't a patchin' fur  
him.

Granddaddy said 'at whenever a squirrel  
'D hide in the top of a hickory tree,  
He'd throw up ol' Bess, give a squint 'long  
her barrel,

An' bust out his eye jes' as slick as  
could be.

Many a panther has fallen before it,  
Many a bear got a dose of its lead,  
An' Injuns was skeered o' the feller 'at  
bore it—

It stifled the warwhoop o' many a red;  
An' deer! Thar ain't figgers enough in  
the backs

O' the 'rithmetic book fur to figger the  
facks.

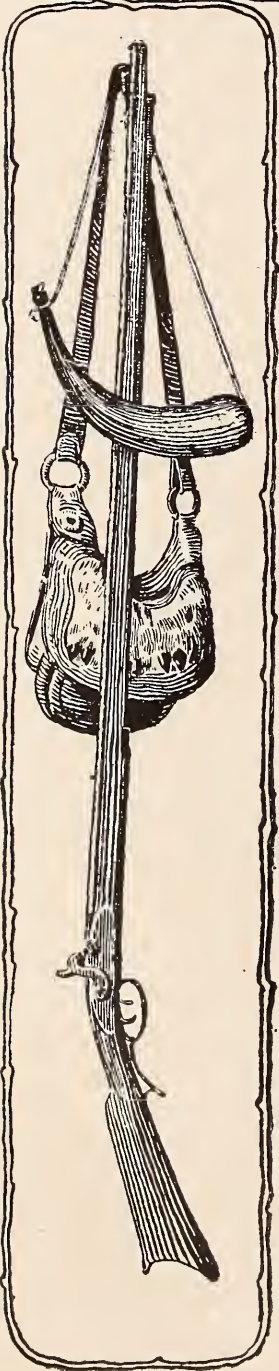



When granddaddy died it was willed to my  
 father,  
 An' when he in turn was jes' passin'  
 away  
 He asked that his loved ones might every  
 one gather  
 About him to hear the last words he  
 would say.  
 He tol' me to take the ol' rifle, an' ever  
 Preserve the proud record she'd already  
 won,  
 An' if I should ever be called on, to give  
 her  
 New laurels to wear; an' he added,  
 "My son,  
 If the flag of our country is ever assailed,  
 Jes' shoulder ol' Bess, fur she never yit  
 failed."

All through the bloody rebellion I bore her,  
 Follered Berdan in the sharpshooter  
 ranks;  
 Many a reb fell a writhin' before her,  
 An' slid into silence a cussin' the Yanks.  
 Thar in her ol' walnut stock is a furrow  
 Made by a bullet a Southerner shot;  
 I sent another right where it would burrow  
 Clear out o' sight in his temple o'  
 thought.  
 See that dark stain? That is blood from  
 my breast,  
 Come from whar traitorous lead found a  
 nest.

That's the gun, stranger. Jes' look her  
 all over;  
 Now do you wonder why she is my  
 pride?  
 Now do you wonder I bless her an' love  
 her  
 More than all else in the universe wide?  
 Granddaddy packed her when Washin'ton  
 led 'em;  
 In Eighteen and Twelve father tuk her  
 along;  
 I 'gainst our brothers down South, an' I  
 fed 'em  
 Lead in small doses, but powerful strong.  
 An', stranger, if war ever hits us ag'in,  
 I've got a big kid as kin shoot her like sin!

## THE GRIZZLY'S GHOST.

STANLEY MAYALL.

No reasonable man could doubt its existence. It had been seen by half a dozen different sober, reliable men; mostly prospectors, whose knowledge of the country was only exceeded by their faith in its mineral resources. It pleased the job printer in the valley, who called himself a newspaper editor, to make fun of that bear and couple its name with the effects of bad whiskey and mountain mist.

"What's it to me, what the darned paper says?" remarked Charlie Goss; "I seen it, Ned Hamlyn, Big Harry and Texas Jim seen it. Hank Graham seen it, too, and so has Hank Graham's dog, and is now dead in consequence. Dogs don't drink, and bears that aren't there can't kill. All these people say the bear's snow-white, they allow he's the biggest they ever seen, and they all come across him within a few miles of the same spot—Peterson's old camp on Silver mountain. That's where Klondyke Jim and Cultus Jack killed each other and a big grizzly as well, a few weeks ago. This bear's that bear's ghost. Shot at it? No! I'm looking for gold, not grizzlies, nor ghosts, nor yet glory. The other boys has though, 3 or 4 times, and hit him, too. Every time he sees a man he comes for him slicker'n hell. He aint afeared o' nothin', an' b're and bye he will make some valuable citizens miss their regular appointments with the bar-keep."

Next week it fell to the lot of the Fire Gulch Sentinel to print a grim commentary on its previous sarcastic allusions to the grizzly. "We regret to report the death, on Silver mountain, of Hank Graham, a prospector of this city. He was out with Dave Flip, hunting for a bear that has caused considerable trouble lately. It is known locally as the 'grizzly's ghost,' probably because it is quite white and is seen only near the place where a large grizzly was recently killed.

"Without any warning the white bear broke cover and charged the men, smashing Dave Flip's arm and breakin' his gun. When he recovered consciousness he found at his side Hank Graham's body, torn and mangled past recognition. A party of hunters will scour the mountain in search of the bear; we wish its members all possible success."

The party set out heavily armed, and accompanied by pack horses bearing outfit and provisions for a fortnight. It returned empty handed, without having seen the grizzly.

About that time there arrived in Fire

Gulch a young Englishman, Algernon Hubert Farquhar, a pretty boy with a pink and white complexion, honest eyes and a clear tongue; quite ready to be gulled by any one who tried it and just as ready to resent it on discovery. He was the completest tenderfoot who ever went West. Why he had come no one ever found out; but come he certainly had, and 6 gun cases with him. Also, as was demonstrated on various occasions, 2 Norfolk jackets, various cloth caps and 3 pairs of riding breeches set off with the latest of old country leggings.

At first, with typical Western intolerance of things not understood by their cramped minds, the denizens of Fire Gulch resented this intrusion. Later, finding the new chum was a remittance man and had, vulgarly speaking, money to burn, they made a change of front, and presently Algernon Farquhar, who could not tell galena from a gallon can, was spoken of by a local paper as a mining expert, the forerunner of a powerful syndicate that was soon to develop local properties.

Now Algie was, in theory, a keen sportsman. In the old country he had made many a big bag of pheasants and moorfowl, and had a notion that bagging bear or caribou was similar business. The pride of his arsenal was an antiquated double gun, one barrel rifled, the other smooth, which the London gunsmith had described as "just the thing for a tour in the Rockies, and identical with the one he had sold Colonel B—, who had performed with it, in India, the unique feat of bagging an elephant with one barrel and a snipe with the other." That settled it; Algie, also, would go and do stunts; perhaps a grizzly and a humming bird would compose his bag.

Then in Fire Gulch Algie heard that uncanny bear yarn and thirsted for gore and glory; he cleaned his gun every 4 hours and awaited opportunities. One morning he received unexpected encouragement from a most influential quarter. Algie was fortunate in having an English sweetheart, and perhaps doubly fortunate in having only one. Feeling lonely in the wild and wicked West he had written this young lady offering her his whole heart and a fair share of his income.

And the lady, Gladys Garmoyle, aged 18, replied thusly: She had received his letter and thanked him for it. She deeply and sincerely appreciated his offer of marriage, but was he not too young to think



of such a proceeding just yet? She preferred to remain free a while longer, but if Algie would find a gold mine or an oil well, or distinguish himself in some way she might accede. In the meantime she begged to assure him she had recently refused 3 offers from men of unquestioned social standing.

Then, of course, there was a P. S. added, even longer and more important than usual.

"I have just tumbled across an American railway guide and in a description of Rocky mountain sport read the following: 'The pursuit of big game is no child's play, especially if the quarry happens to be a grizzly bear. Right well did the Indian hunter know what tested manhood, when first he wrenched the great scimitar shaped claws from the broad forepaw of the dead grizzly, and strung them round his neck to prove himself a man. Time has changed many things, but the grizzly is yet king of the woods, and his skin the most valued trophy of the sportsman.'

"Perhaps, Algie, if you will send me a skin of your own taking we can wait a while for the gold mine and the oil well."

Algie's heart gave a joyous bound. Here was his chance. He purchased 2 Sentinels, one telling of the deaths of Cultus Jack and Klondyke Jim and the other relating the tragic meeting of Hank Graham with the grizzly's ghost. These he posted to Gladys with a brief note:

"My promised wife:

"I thank you for the precious hope you have given me. I send you papers containing marked paragraphs which will interest you. To-morrow morning I start to earn for myself the boon you are willing to

bestow. I vow I will remain in those rock-strewn and timber-covered mountains until either my life or that of the grizzly's ghost has paid the price of your inestimable love. Yours ever, Algie."

That was the last communication Miss Gladys Garmoyle ever received from her would-be husband.

His body was found near Peterson's. He died with his face to the foe and had apparently never flinched. His face bore a smile of confidence and triumph, mingled with mild surprise. On his breast were 3 downward slashes. The rent in his Norfolk jacket revealed, lying over his heart, the photograph of a charming young girl in evening dress. The doctor said death was due partly to shock, but mainly to loss of blood, and added, cynically, that if Algie had had pictures of 4 or 5 other sweethearts in his breast pocket, his life might have been spared for one; but virtue is its own reward.

Beside the boy's body lay that of the much dreaded grizzly's ghost. It had received a ball through its lungs and heart and a charge of shot in its face. It was absolutely sightless when it struck the blow that killed poor Algie. There was considerable discussion as to what kind of a bear the animal really was. Many hazarded the conjecture that it was a stray polar bear that had found its way Southward. A learned zoologist pooh-poohed such notions and remarked with dogmatic decision: "No, it was an albino, undoubtedly rare, but by no means supernatural."

Somehow Algie was hardly discussed at all. One trapper did remark, "Waal, a grizzly ain't fit meat for a tenderfoot no-how, an' he shouldn't a' tried to bite off more'n he could chew."

---

## THE DUCK SHOOTER'S COMPLAINT.

A. M. H.

O wily Widgeon, prithee tell to me  
Why squattest thou on yonder lump of ice?  
Why spurnest thou my proffered company?  
I know thy seat is cold and far from nice.  
Vainly I praise thy beauty and thy craft,  
Still thou approachest not my ice-bound  
raft.

For hours within this hole have I lain low,  
Attired in night shirt and a cap of white;  
My duck-boat decks I've strewn with ice  
and snow—

Thy tardiness is neither fair nor right.  
Ever and oft thy cackling laugh is heard,  
Why mockest thou my plight, offending  
bird?

Hark! what is that? A whirr of wings  
o'erhead!

With trembling hands I raise my gun and  
shoot;

Hard hit! the victim of my shot falls dead—  
A little pee-wee, good-for-nothing coot!

Ah, yes! I can imagine well thy glee,  
Thou hast thy web foot to thy bill at me.  
And here I sit, from head to foot con-  
gealing,

Because of thy most willful frame of mind;  
My form so numb 'tis past all sense of  
feeling—

Dost thou consider this, thy conduct, kind?  
But this it is that most displeaseth me:  
That I've outwitted been by such as thee.

## SIX DENVER BUTCHERS.

Under separate cover I send you a photograph which I got in Denver, and knowing

RECREATION is the only real sportsmen's magazine published. It has helped me to a



The rooters shown in the photograph, reading from right to left are: Edward Sanborn, Mordecai Boring, Frank Anderson Jr., Frank Anderson, George Flieger and H. E. Reed.

Their numbers in the game hog register are 893, 894, 895, 896, 897 and 898.—EDITOR.

your partiality for roast pork, I have no doubt you will find these bristlebacks palatable.

higher ideal of sport and I am sure it will do that for anyone but hogs.

W. A. W., Butte, Mont.

---

Penman: You say you like my books?

Wright: Well, I'm stuck on 2 of them.

"Which 2?"

"The 2 I bought."—Yonkers Statesman.

## A NIGHT IN A FISHING HUT.

W. ROGERS.

In the latter part of November, some years ago, when I was still far from my camp, darkness began to fall on a night which threatened to be cold and stormy. I had been rowing steadily the greater part of the day, and was ready for supper and rest. I looked about for some place which might afford me shelter, or a convenient spot for my overnight camp. A short distance ahead of me a long, low point broke the usually regular shore line. For a little distance from the water's edge it was bare of trees, and on this clear space, but close to the dark background of forest, I saw a cabin. I was somewhat familiar with the spot; I knew the cabin and its owner, and twice before I had stopped there for a few minutes' rest, or to eat my mid-day meal. A few strokes of the oars ran my boat on the smooth shingle of the point, and, jumping out, I turned toward the shanty and hailed. A man, standing in its doorway, answered, and moved toward me. This was Hank, or "Soldier Hank," as he was sometimes called by the fishermen, guides and woodchoppers of that wild and sparsely settled country. The dwellers in those woods seldom spoke of him, and when, infrequently, they passed his cabin, they did so without hail or salutation, and with quickened stroke of oar or paddle; and, if daylight had passed, they preferred the discomfort of lying out, to the shelter of his roof. They said he was "strange," a "curious fellow," who talked and hollered at night, and one said "he had heered he'd done suthin' unlawful," but added, quickly, that he "didn't know the rights of it; mebbe twas on'y talk." Beyond a taciturnity unusual even in the woods, where men observe much and say little, I had noticed nothing singular about him in the brief conversations I had had with him.

As he came near me I held out my hand. "I'll stop the night with you, Hank," I said. He nodded, not noticing my outstretched hand, and, stooping over the boat, began lifting out my traps. "Go inside," he said, "there's a fire, an' don't stumble over the cheers."

I turned to the open door and entered. Groping about in the thicker darkness of the room, I found a bunk, on which I threw myself and waited for Hank. He soon came, laden with my things, which he threw on the floor, and, lighting a small lamp, began to prepare supper. Having cooked my meal, he seated himself before the stove, with his back to me while I ate; and when I pushed back from the table, he

rose to clear away the things. This done, he returned to his chair, where he sat silent, leaning slightly forward, his elbows on his knees and chin resting on his hands. He was a man below the average height, and slender, his face lean and dark, with a straggling grey beard; a man of about 50 years, I thought. His eyes were dark and restless, and he moved in a quick, silent way. He had come from Pennsylvania, where he had hunted and trapped before the war, and from which State he had enlisted. Wounded, and discharged with a pension, he had wandered to this spot.

I filled and lighted my pipe, and drew a chair near him, by the stove, thinking to chat a little, before turning in. He took no notice of my approach, save by litching his chair a little to one side, and so we sat; I casting about in my mind for some proper subject of talk. Not finding one, I asked questions relating to himself.

"Don't you ever get lonesome here, through the winter, Hank?" I asked. "Do you ever see anyone?"

"No," said he, "not often, but I don't know as I git lonesome, egsackly. I kin most always find suthin' to do daytimes, fishin' an' shootin' an' putterin' 'round, an' thin I ginally git to bed pretty airly, when it's quiet. I got an' accordeon under the bed thar, an' I play onto it at night, when the wind blows like it does now, hard an' noisy like. A feller give it to me 7 year ago, an' learned me to play it, only one tune, though. That was the same year that he"—he broke off abruptly and looked behind him toward the door and began again, absently. "I got a Bible under the bunk, too. Times I read that; not on windy nights though—not then; on'y in still nights when ye can't hear nothing unless ye listen close; little sounds, crackin' an' rustlin' like; no harm in them sounds, an' nights like them I read the Bible, in th' old test'ment. That's the best part o' the book; they let a man stan' up fer his rights, an' ef enny man tries to put on ye, why he jes' takes his chances an' that's all they is to it; ye got a right to keep fer yerself, 'cordin' to th' old test'ment." He stopped and listened to the increasing tumult of the wind. "Seems to me I haint talked as much as this fer a year; seems as if I'd got ter talk to-night. Ye've been alone some at night," he went on, with a half question in his voice, "with no human bein' near ye? In the woods an' on the water, when it was blowin' hard, too, p'raps, have ye?"

"Why, yes, Hank," I answered, "a man can't live in this section without being alone sometimes, and I've had my share of it."

"I heard so," he replied, "I heard so," and leaning a little toward me and dropping his voice, "don't ye go for to think I'm loony if I ask ye suthin'. Some o' the people 'round here think I am, an' don't come nigh me, 'cause they've heard me talkin' alone; but I ain't. Say," he continued, hesitatingly, "tell me, have ye ever, at night, when its blowin' like this, heard anythin'?" and he drew back and waited for my answer.

"Heard anything?" I repeated, "why of course, many sounds. A gale like this makes a great rumpus at night and one can hear hardly anything else."

"Not them sounds," he interrupted, "taint the wind. I know every sound the wind makes, zippin' an' whizzin' 'round corners an' cracks, an' rushin' an' groanin' in the woods; taint them sounds, them is jes' nateral wind sounds, when anything gits in its way. I mean people, when ye know there ain't any; talkin' like. Did ye ever hear that? I have," he went on quickly, "often. An' after I've heard 'em I don't know who they be, nor what they're sayin'; but I kin hear the words—shoutin' an' whisperin' all confused like. Sometime I think if they'd on'y say 'em over agin I cud kinder sense what 'twas they was talkin' about, an' there is times when I do understand 'em. Mostly though it's all jumbled an' mixed up; an' yet ye can tell plain enough they're conspirin' some trouble fer somebody; plannin' an' consultin' an' then away they go agin, rushin' off to drownd some mis'able, shiverin' sailor er help burn a house, er hurt somebody some way."

"Gosh a'mighty! hear it," he cried, at a burst of wind. "Seems as if they'd all turned loose to-night"; and he reached under the bunk and drew forth the old accordion.

"Ef ye don't mind I'll play," he said, and began at once to push and pull and finger the instrument so vigorously that, notwithstanding much air was heard to escape, through many cracks and holes, it at last gave out an unwilling noise. Some of its keys refused to work or perhaps Hank had never been properly taught, or had forgotten how to use them. Two notes, however, sounded continuously; a monotonous droning sound, with a little regular catch at the slight pause between the push and the pull. The same strains were repeated over and over again. He played a tune which I concluded was intended for the air of "Annie Laurie." So we sat for nearly an hour, I smoking, he playing. When the wind pushed harder against the house he redoubled his exertions and I could hear

his stiff and calloused fingers striking against the keys like chafers beating at night against a lighted window.

"For mercy's sake, Hank," I exclaimed, at last, "stop that, or play something different."

"Don't ye like it?" said he, with a note of surprise in his voice. 'Pears strange ye don't. It's better 'n listenin' to them danged people outside. I don't know no other tune, an' I don't know as I want ter. I've got kinder used ter this one, an' I know jes' how it goes, an' jes' what's comin'. That's why th' winds rile me up so; they're so onsartin ye can't never tell what they're up to. Some nights I should think I've played nigh a thousan' verses o' that tune; perhaps not a thousan', but I calc'late it takes me 'bout 2 minutes to play a verse, an' I've played her stiddy from 'bout 4 in the aft'noon till 'bout 7 next mornin', takin' out what time I used puttin' wood on th' fire. Its kinder calmin' to th' mind, I think, but I'll quit fer a while ef it goes agin ye."

"When did you get the accordion, Hank?" I asked. "You seem to value it highly."

"Yes," he said, stroking it as if it had been some pet, "I do set considerable store by it. My partner give it ter me 'bout a month afor—afor he quit. You d'dn't know him. He quit 'fore ye began to go by here. He left 7 year ago this month—yes, an' this day. Good, stiddy, quiet feller Adam was; ye wouldn't want a better one ter live with. Me an' him never had a word, not a word, fer 10 years, an' slep an' et together, an' that's sayin' a good deal; ye can't say any more. Bein' friends with a man in th' woods aint like bein' friends with him outside, cause there ye can get away from him fer a spell, ef ye want ter; but ye can't git away from him in here, an' ef anything goes wrong, why, thar he is, the last thing at night, an' the first thing in the mornin', stickin' as clus ter ye a'most as ef he was yer conscience, an' sometimes ye git ter hate him a'most as bad as ef he was. Ye git so tired o' seein' him, all'ays jes' the same an' never changin' a mite; an' it seems sometimes a'most as ef ye was married to him, an' I tell ye it's terrible tryin'. But 'twant never so with him; no sir! I never see a man like him. When I had my fever so bad he went out ter the edge and hired a feller ter go an' git some medicine fer me an' paid him \$6 fer it; and he come right back an' stayed with me an' then went out agin' ter fetch th' medicine in. In January 'twas, an' the snow 5 foot deep; froze his hand an' his foot stiffer'n a gun barrel; that's what he done, an' I couldn't never git him ter take back th' \$6."

He stopped and patted the old accordion, and I said, "I never knew anyone lived here with you, Hank. Didn't he come back? Where is he now?"

Hank turned and looked at me with a steady questioning look. "I dun know where he is," he answered, "not fer sure. I've a notion ter tell ye," he whispered, "I've often thought I'd feel easier ter tell someone; thought of it ter night when I see ye comin' in here, an' then I give th' idee up agin. Ye aint a talkin' man?" he asked, and, without waiting, answered himself. "No, I know ye aint. I kin tell gin'ally. Ye'll keep yer mouth shet an' ye can't do no good by talkin' anyways. Promise."

"All right," I said, and made ready for his story by again filling and lighting my pipe, and adjusting myself more comfortably in my chair.

Hank had placed the accordion on the floor, by his side, and resumed his leaning position. He sat without speaking so long that I thought he had forgotten me. Then, without changing his position, he began:

"Seven years ago today I come home from fishin', 'bout 3 in the afternoon, an' found a man here talkin' with Adam, my partner. Adam made us acquainted an' said th' feller was a lawyer. The feller said he'd come 'bout some property belonged to Adam—been willed to him—an' said that Adam must go West with him, where the property was, or else give up some writin's he had. Ef he'd give him up the writin's, he'd settle the business an' Adam needn't to bother 'bout comin'. I hadn't never seen no writin's, an' I said so; but Adam he said, yes, he had 'em, and then he showed 'em to me, tied up with a red string. The lawyer he said the papers 'uld do jes' as well as Adam goin', but Adam wouldn't give 'em up. Well, they talked together an' kept argyin' till after dark; but I didn't hear much o' what they said, except that the lawyer urged Adam ter give him up th' writin's, and Adam refused ter give 'em up. Then they went outside and I heard Adam talkin' loud an' excited like, an' at last he hollered out. 'Well then I'll go,' an' then he come inside an' says he, 'Hank, I got ter go, an' the sooner I go, the sooner I'll git back,' an' he began makin' up a bundle. 'Lords sake, Adam,' says I, 'don't go to-night, wait till daylight. It's blowin' hard an' it's dark, an' ye can't git through the woods, to say nothin' o' gittin across in the boat.' 'No,' says Adam, 'I'm goin' now. We'll git over all right, an' I know the trail well enough to feel it a'most. I'll be back in a couple o' weeks or a month anyway,' says he, an' he grabbed his bundle an' his gun, an' he put the writin's in his coat, an' went out an' me an' the lawyer we went out after him. When

I got down to the shore, Adam he was shovin' an' pushin' at the boat like a crazy man, tryin' ter git her turned 'round so's we could shove her in bow first, on account o' the sea rollin' so; an' we shoved her in an' Adam says ter the lawyer 'git in,' says he, an' he got in the starn an' Adam give him his bundle an' his gun. Well, they started, Adam rowin' an' the lawyer sittin' in the starn. 'Twas blowin' most too hard fer 'em, but Adam was a good man in a boat. There was a leetle moon, 'bout a quarter full, an' a few clouds driftin' fast over it, an' thicker ones comin'. I stood an' watched 'em till they was out o' sight, an' fer a long time after I stood lookin' at where they'd gone an' then I hollered out, 'Good-by Adam,' says I; fer it had all happened so suddin' I was kinder dazed an' hadn't thought o' it afore, but I don't spose he culd a heerd me, fer they'd been gone 'bout half an hour. Then I started fer the cabin, feelin' kinder low spirited. 'Twas 'bout 7 o'clock, I guess, an' jes' as I turned I heerd a gun go off an' a yell. I wheeled 'round, an' there they was agin. I culd see 'em plain, standin' up in that bobbin' boat, an' they had holt o' each other an' was wrastlin'. Then a cloud come, an' I couldn't see nothin', but I heerd 'em over the wind, cursin' an' chokin', an' then I heerd a yell agin—a dyin' man's yell, like as I've heerd 'em in the army; an' I ran down to th' beach, an' I yelled ter 'em, 'stop; God A'mighty, stop!' an' I shoved my boat off an' jumped in an' she swamped, an' I kep' shovin' her in, an' she kep' swampin' till I was nigh drowned. I didn't know nothin' fer a good while, an' yet it seems ter me I kinder remember runnin' up an' down the beach stumblin' an' fallin', but I aint sure 'bout it." Hank paused, and I could hear his jaws working like those of one trying to swallow with dry tongue and throat.

"Well?" I said, inquiringly.

"That's all," said Hank; "I haint never seen him since. I found the boat, 2 days after, on t'other shore, an' on that night the wind was blowin' nearly on this shore; but it might have drifted over when the wind changed. The boat had one oar into it an' that was all, an'," he added, with a quivering voice, "it had blood on it—on the seat an' on the rail; it might ha' been from fish, fer Adam had been spearin' the day he left, an', besides, I should ha' thought fresh blood wuld ha' washed away such a night as that was; but I've heerd that a man's blood, spilt unlawful, don't wash away easy."

Hank was, by this time, in a state of dreadful agitation. He looked nervously at the door and window, his hands opened and shut and the sweat broke out on his face.

"What do you think?" he questioned, "what sh'uld make 'em come back to this side agin' so long after they'd started? What was it I see an' heerd? was it him or"—he choked, with a dreadful sound, and rocked himself to and fro, pulling at his beard. His terror infected me. I feared he would go into a fit, but I knew not what to do. I thought of the whiskey flask in my basket, and rose hastily to get it. As I rose, he uttered a loud inarticulate cry, and half sprang at me, and shouted: "Sit down, sit down! Where ye goin'? Oh, God A'mighty!" and fell back motionless in his chair. With a shaking hand I put the flask to his lips and in a moment he recovered, and taking the flask he drank from it. I did the same, after him. Then Hank began to speak again, more quietly, but his voice still trembled:

"After a while th' people 'round here missed him an' I told them he'd gone out, but he haint. He's there yit, an' nights like this he hollers out an' the other feller too, sometimes—quarrelin' an' 'cursin'. I quit here once, after that, but I had to come back. Seems as ef I was obleeged to come; I can't stay away an' I can't hardly stan' it here." I waited for him to say more, but he did not speak, and so we sat for a half hour, an hour—I know not how long. "Better git to bed," he said, at last, quietly, "ye must be tired."

"And you, too, Hank," I answered, "go to bed and try to sleep."

He shook his head. "I haint sleepy, not yit," he replied; but he rose and threw some wood on the fire, and, pulling some blankets from the bunk, tossed them on the floor for his own bed. I partly undressed and threw myself on the bunk, and soon slept. After a time, how long I do not know, I dreamed that I heard music, and I awoke. It was the sound of the old accordion, which had seemed like harmony to my listless ears. Hank still sat before the stove playing softly, and I watched him as I lay. Occasionally the music ceased and he lifted his head a little, turning it to one side and listening, when the blast roared louder. Once he looked quickly up and rose and went swiftly to the door and stood there a moment, leaning against it, in an intense, attentive attitude. Then his hand dropped wearily to his side and I heard him sigh; and he came slowly back to his chair and began again on his tune. It sounded fainter to me, and fainter. The outlines of the room grew dimmer—my eyes closed, and I slept. When I awoke the gray light of morning was stealing like a mist through the dingy window. The

storm had blown itself out and I heard, faintly, the sound of waves on the beach. On the floor I saw the form of Hank, indistinct in the feeble light, one arm stretched out over the rough boards, the hand just touching the old accordion. I heard his breathing, soft and regular, as he slept. There, too, the storm had ceased and peace was visiting him.

I gathered my traps quietly, laid a dollar on the table and stepped softly from the cabin. In a moment more I had stowed my luggage in the boat, had shoved it afloat and rowed rapidly away.

Some years after this I met a man who knew Hank slightly, and had known Adam well. "Did you ever know what became of Adam?" I asked. "No," he replied, "Adam just disappeared, without any reason, leaving no word or clue, as far as anyone could discover. Hank told a very improbable story, when questioned about it; said Adam had started off, at night, with a stranger, to see about some property, and hadn't told him where he was going. One thing was established pretty clearly, Adam never came out of the woods. I don't, myself, believe he ever started, but if he did, he never got through, and I'll tell you why I'm sure of it. Coming out the road Hank said he took, and the only road he could take, he would have passed right through the settlement and everybody knew him there, and some were friends of his, whom he never failed to call on when he came out; yet no one saw him, nor any stranger either. Then, in the next place, he was advertised for in a newspaper. I don't mean there was any reward offered, or information asked for; it was in some legal proceedings, before a Surrogate, and that was 3 or 4 months after Hank said he had started out. Adam had plenty of money and used to show quite a roll of it when he came out to buy provisions. The general opinion was that Hank had done away with him, in some manner; either in a quarrel or for his money. It was a mysterious case and I never knew what to think of it."

"Well," said I, "I'll tell you something. I don't know whether Adam was killed or not; probably he was. But there's one thing I do know. Hank didn't kill him, and never raised a hand against him."

"You seem pretty positive for a man who was not there," he answered. "However, I hope you are right, but if Hank didn't kill him who did?"

"I don't know that, either," I replied, "Perhaps it was the stranger."

---

Boomerangs and evil thoughts act in a similar fashion.

## FROM THE GAME FIELDS.

The man who quits when he gets enough, with plenty of game still in sight, is a real sportsman.

### IN THE OLYMPICS.

It was only after Mr. Battleford and I had made many plans that we finally got away from Tacoma the night of October 15, last, on the steamer Sentinel, bound for Seattle. There we took the steamer Garland, and after crossing historic Puget sound, made final preparations in Port Townsend for a long hike up the Elwa river. Our 55-pound packs a farmer took to the Six-mile ranch in his wagon, while we walked through the giant firs, past shingle mills that were slashing away at the great logs. We were not accustomed to traveling, and when we took up the packs at the ranch they seemed heavy; but we were enthusiastic, and marched along as best we could. Ten miles out we left the road for the trail that winds along Hurricane mountain, following the beautiful Elwa, the roar of whose waters made music in our ears as we passed many varieties of ferns and giant firs. Then followed a climb along the mountain side, now near the river bed, now up a steep grade for 20 miles, until we came to Geysers valley and the cabin of Mr. Anderson, who was away; but as the latchstring is always out in this country, we entered, built a roaring fire and prepared supper.

At 3 o'clock the next day we were baking doughboys in the Dutch oven and eating our last meal on the edge of civilization. Then we began the ascent of a ridge 5,000 feet high, the scenery changing constantly until we could look far away and see the glaciers and the snow. We took but a small bottle of water, and as there was none until the summit should be gained, I gave out. We camped on the trail, where we found a bottle of water providentially left there by someone else. I passed a miserable night, full of pains and aches, and it seemed we would never reach the summit the following day; but in time we came to the lake, obtained some fresh water and set the tent just in time to enjoy its shelter before rain began to fall heavily. Then my partner went out and shot some grouse.

We were disappointed in finding no game Monday and Tuesday, so pushed on again, across the treacherous, slippery snow, falling at times and getting many bruises, but keeping on until evening, when we came again to the Elwa. Building a fire, we dried the ground before pitching the tent, and made a bed of spruce boughs. We rested the following day, and found enough grouse for food; then pushed on again until, after crossing the Goldie river, we found

evidences of bear and elk, and made camp.

We had not been separated long the next day before I heard Battleford fire a shot, and shortly afterward saw a bull elk below me, some distance away. I dared not try to get closer, so drew a bead with my old .45-90 Winchester and fired. The elk did not move at the first shot, but dropped at the second, got up and staggered away, with me in hot pursuit, and in a few minutes I finished him. This bull had good antlers. Down the trail I found Battleford with 2 deer.

We smoked our meat and our pipes while awaiting better weather, but as that did not materialize, we broke camp November 4, and going down the Lillian, finally reached Anderson's camp. There we dried out and ate bear steaks and deer liver which Anderson cooked for us. This bear meat was from a young cub Anderson had killed. We rested there one day, and arrived in Port Townsend in good time after our long tramp.

Game is still abundant in the Olympics, but difficult to find on the Elwa because of the down timber that fills the trail, making the assistance of a pack horse impossible. The game is far back in the mountains, and there is considerable killing out of season.

Frank Parker, Tacoma, Wash.

### CAPE COD QUAIL SHOOTING.

I read in February RECREATION an article by J. A. MacKenzie asking that more be said on the sport of grouse and quail shooting. I should like to take that gentleman by the hand and say amen to that article. There is no time in the year to which I look forward with more pleasure than the opening of the season for quail shooting. We have no deer shooting down here on Cape Cod, but we have quail shooting; and what sport can be more invigorating than a long tramp in the crisp air of an October morning scented with spruce and pines? Dyspepsia is a stranger to a faithful follower of the sport, and I am one.

Many of the natives on Cape Cod do not care for quail or grouse shooting, as it is too much work. They would rather sit all day behind a blind and wait for ducks and other sea fowl to come to them. We also have sportsmen, so called, who come from Boston and vicinity, bringing all the required utensils for quail shooting, but when told that the quails are to be found one or 2 miles away, they are content to stay in the hotel and play cards, and ask if you

know where they can buy a few birds to take home.

The most important thing in quail shooting is a good dog. They are few. Do not look for pedigree. Buy a dog that you have seen work in the field. The best dog I ever saw, and I own 3 to-day, is a black setter, handsome as a picture, and the result of crosses between English, Gordon and Llewellyn setters. Almost any kind of a modern gun will kill quails, but get one not bored to shoot too closely, as most of the shots are made at short range. If you use a choke bore, holding close on the bird, as you have to do in order to kill, often your bird will be worthless.

One can nearly always make the best bag alone, for he does not have to wait for the other man to have the first and best chance. Then again, when alone, there is no danger of filling a friend with shot while he is standing behind some shrub.

I have always found warm, lowering days best for quails. Look for them early in the morning and about one hour before sunset, on their feeding grounds. I have killed more quails between sunset and dark than at any other time of day.

The quail's favorite feeding ground is an old stubble field, grown up with bitter-weeds, which furnish abundant seed for food. A quail killed in the middle of the day rarely if ever has any food in his crop. They eat sparingly in the morning, but when killed after supper their crops will be found full.

Never shoot at a covey of quails while they are on the ground. That is murder in the first degree. Only a game hog would do it. Flush the covey, but never shoot point blank into them as they rise. Make a point of shooting the first bird that rises. Then you will have plenty of time for your second barrel.

Every lover of grouse and quail shooting should kill every house cat seen on or near the feeding grounds of these birds, for cats have destroyed more young birds, before they were able to care for themselves, than have ever grown to maturity. I have met many an old farmer, while tramping around for quails, who has told me what a smart cat he had, and how every day or 2 she would come up to the house with a young quail in her mouth. It makes a man look around to get a glimpse of that lovely cat, so he can recognize her when they meet under more favorable circumstances.

J. E. Taylor, Orleans, Mass.

#### A TALE OF A 'POSSUM.

In 1883 I was the proud owner of a knowing dropper, which, I will explain for the benefit of the uninitiated, is a cross between a setter and a pointer. He was a good all around dog, hard to beat on any

ordinary game, and among his other accomplishments he would often nose out the lair of an opossum.

A friend, having been presented with a beagle, wrote me to secure a live 'possum on my next trip to the country and bring it to his place on the outskirts of Philadelphia. He agreed to pay me for it, for the sake of letting his beagle run it by moonlight. I was much pleased, therefore, when a mile from the farm my dropper, Don, gave unmistakable testimony to the presence of a 'possum in a hole. I stayed by the tree with Don while a boy ran to the farmhouse for an ax, for which service I gave him a quarter, and on enlarging the hole we extracted 2 fair sized opossums. Placing them in a sack, I started for the farm, and later in the day for Philadelphia, after writing my friend that I would bring them over the next night.

Right there my troubles commenced. I foolishly showed them to a Scotch terrier in my boarding house, and from then on he made repeated trips to the cellar door in hopes of getting at them. Hardly had I got to sleep before the landlady called me to say that Jack was clawing at the cellar door and kept her awake by his efforts to get down to the box. I got up and put the box out in the yard, and Jack at once commenced to gnaw the back door to get out. I took my captives upstairs to my room, only to have Jack turn his attention to my door. Determined to keep them alive and get my money, I at last took both Jack and the box of 'possums to my room, tied him to the leg of my bed and by occasionally admonishing him with a whip got a little sleep.

The next afternoon brought a letter saying my friend was temporarily hard up and unable to make good, but if I'd bring the 'possums over I might see his dog hunt them. Much as I should have liked to participate in a hunt, the memory of the trouble I had taken in bringing the opossums to town, all the while in anticipation of the payment of \$2, and remembering, too, the quarter I gave the boy, I decided to give the animals to our darkey wash-woman instead. With the feeling of doing a commendable act, I took them to her house. As soon as she saw they were alive she handed back the sack, saying she could not kill them.

I took them back home, loaded my gun, turned them loose in the yard and, through a slightly opened door, made a quick double shot. Every back window on the next street flew up, but after the excitement had died down I retrieved my game and once again started for the darkey's house. As I drew the victims from the sack she exclaimed, "Sakes alive! They ain't cleaned, and I can't clean 'em." In des-



peration I slung them into the sack, and seeing an ash barrel near the curb, I hastily tossed bag and 'possums into it, mentally calling myself every kind of a fool for all the trouble I had been to.

Bunny, Somers Point, N. J.

#### CAMPING IN THE HIGH SIERRAS.

Last fall 7 of us went up into the Mount Whitney country in the Sierra Nevada mountains. This is the highest mountain in the United States, 14,898 feet. It is on the boundary line between Inyo and Tulare counties in California. The country surrounding it is as rough as one would wish to find and the scenery is grand.

We left Los Angeles the first day of September, 1902, with a covered wagon containing our provisions for a 2 months' stay, and 4 saddle horses. Traveling through Mojava, a place on the Mojava desert well known in Southern California, and up into Red Rock canyon to the desert between the Panamint range and the Sierra Nevada mountains, we came to Haiwee meadows, 220 miles from Los Angeles. There we secured pack mules and other necessities for a trip by trail over the mountains. It took us a day and a half to get over the first range and down to the South fork of the Kern river, a small stream full of trout, with the hills alive with deer and smaller game, a place where hunters seldom get. We camped there 10 days and then took up the trail to Whitney, a pack of 3 days, passing through some rough country made doubly hard on account of no distinct trail.

Reaching the foot of Mount Whitney we made camp and caught a number of golden trout. This species is little heard of. It is a most beautiful fish, and pure game. Its home is in Whitney creek. This trout is in general not more than 6 to 8 inches in length. It resembles the common brook trout in form, but has a dark, spotted back, a brilliant golden stripe on each side and is yellow on the under side. These fish will only live at a certain elevation. Fishing here seems as in a fairyland, where the angler pulls out a gold nugget at every cast.

Leaving that camp we followed Whitney creek about 8 miles down a rough trail over old lava beds and natural bridges and into a country about 5,000 feet lower. There we came to the Kern lakes, 2 lakes divided by high mountains. These lakes were formed by an earthquake, many years ago, which started a slide of loose rock, etc., on the mountain sides and dammed up the Kern river where it passes between 2 high peaks. We had some good hunting there, for deer and bear. Grouse and mountain quails were numerous and the lakes were full of large trout. That place I regard as the ideal spot for hunter, angler or moun-

tain climber. It would seem to me difficult to find any mountain country to compare with it, and why it is so little known I can not understand. The views are unexcelled. The trail is not difficult for anyone prepared. Anyone who appreciates a trip in the mountains will find this high Sierra country a pleasure long to be remembered.

There are several ways in which a party may get into this country, but the easiest and best is by way of the Kings river canyon and Mineral King trail. That route passes through the Giant forest and Sequoia park, where are the largest trees in the world. No guns are allowed in these parks without a special permit.

Harry R. Palmer, Long Beach, Cal.

#### KILL THE CATS.

Farmers' cats play an important part in the destruction of game. Many cats live by killing and eating vermin that overrun the granaries, but cats are more destructive to insectivorous birds and to small game than all other known causes. I know a farmer who owns 5 cats. He told me they kill an average of one rabbit or ruffed grouse every night during spring, summer and fall.

"I reckon them cats 's good fer a couple hundred head er game, 'sides small birds an' sech last year, 'thout any help frum hunters," said he.

I have repeatedly seen cats in the woods and along the hedges and fences, hunting with a patience unequalled save by human beings. I have compared notes on finding the remains of animals and birds killed by owls, foxes, weasels, minks, red squirrels and cats, and am firmly convinced the latter destroy more than all the others combined. These comparisons were made on snow, when one can see the telltale tracks. I have tried in the summer, too, but with less success. Although I have often seen cats catch birds of all kinds, and full grown rabbits and squirrels, only once have I caught a cat in the act of killing game birds, and that was while watching a brood of ruffed grouse and a nest of black ducks, not 20 rods apart. The grouse hatched only 5 eggs, the others not being fertile. On the following day I found only 3 chicks, which seemed queer, as no foxes or weasels were near. Next day a friend said the duck brood had increased considerably, and on my way to shoot frogs I looked for them. Presently I heard a commotion near, and saw the drake circling about, while the duck was diving and quacking in distress. Just then the boarding house cat emerged with a duckling in her mouth, and I stopped her with a .22. This cat had traveled a mile from the quarries. The owner forbade hunting at all times, and the employee who brought a dog there was

discharged. Still, the owner kept 4 or 5 cats, ignorant of the harm they did. The cat's owner admitted having seen it eating small birds, and we found the head of a grouse chick it had left that morning. I have met 3 or 4 of these worthless scamps in the Adirondacks, their food consisting of small song and game birds. If a dog were even suspected of this sort of thing it would be killed at once, but a cat is equal in destructiveness to 100 dogs. Generally the greatest harm is done near farmhouses, although I have met cats 6 or 7 miles from any house. I will kill on sight every cat I find roaming the woods. Comparisons I have made in districts where few cats are kept and others where they are kept at every farmhouse have proved my assertions. Some action should be taken by the lawmakers, as there is no closed season on cats.

G. A. Newton, Utica, N. Y.

#### GAME PRESERVES NEEDED.

For the first time I am compelled to disagree with you. The people of Wyoming do not want any such law as Senate Bill No. 6689. We have State game laws and we have all the reserves within our State that we desire. Our Representatives will fight the proposed law as long as there is any chance of defeating it. Government reserves at the present time cover  $\frac{1}{8}$  of Wyoming. Make a few reserves in the Eastern States and see how your people like it.

C. W. Morgareidge, Wolf, Wyo.

#### ANSWER.

I do not think there are half a dozen men in any Eastern State who would object to the creation of game preserves therein. On the other hand, there is a general demand from all these States for such preserves, and we hope to induce Congress to set aside large tracts in Pennsylvania, the Adirondacks, Northern Maine, Minnesota, Northern Vermont, Virginia, West Virginia and North Carolina in the near future. None of these would, however, be so important to the country at large as would the tracts we are trying to reserve in the West, for that is the home of the elk, bear, mountain sheep, goat, mule deer and antelope.

I regret to have to disagree with anybody on any question of game preservation, but we cannot all see these things alike. I trust the time will come, however, when you people in Wyoming may be generous enough to allow a certain tract in your public lands to be held as a breeding park for game. The fact that such area may be made an asylum for the game would not be depriving you of any valuable asset. The land would still be there; the timber on it

would be preserved and your people would get more benefits from the preservation of the game there than would those of any other State or of all other States combined, for the game would soon overrun the areas set aside and stock the surrounding country just as that in the Yellowstone park has done.—EDITOR.

#### FROM DAYLIGHT TO SUNRISE.

About 4 o'clock one evening last November, my partner and I hitched my spotted pony to a wagon, and taking my gun and lunch, drove to the lake for the early shooting. This lake is a mile long and covered with rushes turned gray by the frosts. Arrived, my partner drove back, while I gathered up all the robes and passed a comfortable night in the wagon. Dawn the next day found me in a boat among the rushes. Ducks were all about me, but for a time I dared not shoot, as it was not light enough to distinguish ducks from mud hens. In time a streak of red lighted the sky over Mt. Blanco, and rising, I saw 7 big greenheads not 4 yards away, with their heads under their wings, while 40 yards beyond them were 50 more, all asleep. In my excitement I did not know which shot to take, and while I hesitated I heard a "honk" behind me. Turning my head, I saw 3 geese standing in the rushes 12 yards away. I shot one of them, but as it flopped about and I was intent on killing it, I let the other 2 get away. I killed 3 of the redheads, however, when a shell stuck in my pump gun, and before I corrected this the other ducks were gone. Then a whistle over my head made me turn in time to kill 7 out of a big flock of ducks and cripple 2 that got away, although they were not 10 feet distant when I fired. My shots startled a bunch of ducks on the other side of the lake, and as they passed over me I fired 2 shots, but without result.

Most of the ducks had by that time gone to the river, so I gathered up a goose, 3 greenheads and 7 mallards just as my chum arrived on his pony with a pail of hot lunch. While eating I rowed up the lake, getting a mallard and 2 teal. It was with joyful hearts that 2 15-year-old boys drove home as the sun was rising.

W. P. F., Denver, Colo.

You should have given the birds a chance for their lives by putting them up before shooting at them.—EDITOR.

#### NO SALE IS THE ONLY PROTECTION.

I have hunted and fished in pretty much all of Michigan. Have hunted deer 7 seasons, and I want to register a kick about the present deer law. It seems to be made for rich men only. I am a poor mechanic,

and although there are seasons when I can spare the time to hunt, I can not afford to lose the time and pay the whole expenses of a trip. I don't find any fault with the number of deer allowed to each gun. Two is enough, and I should like to see the law changed so that those 2 must be bucks 2 years old or older; but what shall I do with even 2 deer which I can neither give away, sell nor eat?

I like your idea of protecting squirrels. I bought from a farm hand near Lansing an Albino red squirrel, snow white. Is it a freak of nature or a distinct breed? It is very tame and a jolly pet.

J. M. Howe, Plainwell, Mich.

ANSWER.

You are mistaken in assuming that the rich man can kill all the deer he wants. The laws are made for the rich and for the poor alike, and I would never condone any discrimination in favor of either class. I am a poor man myself, and I want to have the same hunting privileges that millionaires have. I would be perfectly willing for hunters to be allowed to sell their venison if such a privilege could be granted them and not abused, but it would be. If a meat dealer in your town should buy a deer of you and several others from other men, the chances are 10 to one he would smuggle the meat out of the State in violation of law, labeling it veal, mutton or anything else that he saw fit. This has been tried thousands of times, and the only way to protect game successfully is to prohibit the sale of it absolutely.

The Albino red squirrel you mention is simply a freak. Albinism occurs in nearly all species of birds and animals, including human beings.—EDITOR.

SLAUGHTER IN THE SOUTH.

Recently I made a short trip through Tennessee. At Medina, a small town near Jackson, the people were telling of the great sport to be had on an island in Forked Deer river, killing robins for fun and money. This island contains 75 acres grown up to rushes and cane, and in this place the robins flock at night to roost. During their Northward flight they come in thousands. In order to get them, all the hunter had to do was to take a stout stick and a lantern with a reflector, flash the light on the birds and knock them off the roosts like apples from trees, the light blinding the birds so they did not know where to fly. One hunter said he had made \$65, another \$27, and several others smaller sums, they finding a ready market in New Orleans at 30 to 40 cents a dozen. I was surprised to learn this, as I came from a State where robins, as well as all other song birds, are protected. The express mes-

senger said he had shipped in one day nearly half a carload of robins to New Orleans. I have seen hundreds of robins offered for sale at the French market every year. Can not something be done by the true sportsmen of Louisiana and Tennessee to stop the wholesale slaughter of robins and meadow larks in this manner?

Ducks seem to fare no better. Charles Sayers, of New Orleans, told me he killed, in a short time, one morning at the Mississippi jetties, over 100 ducks; while some brothers there killed 200 to 250 a day. He also said that on that morning one could shoot ducks with his eyes shut. This he called sport. The ducks are shipped from New Orleans to all the principal cities of the North, as New Orleans consumes but a small portion of them. Last season ducks were scarce in the North, and I do not see where there is any chance for improvement with this slaughter going on in the South.

M. L. Gaze, Fenville, Mich.

A GRANGER SPORTSMAN.

Here are some extracts from the letter of a Maine farmer who does not approve of the great raft of twaddle which is being unloaded by certain people in that State about deer destroying farmers' crops:

I am a farmer and a granger and I own nearly 1,000 acres of good land in one of the best sporting sections in Central Maine. There is scarcely a day that deer or moose are not seen about my fields or pastures—and I say, "God bless them; give us more of them, and still more stringent game laws." I am not one of the "sturdy farmers" of Androscoggin county, who are occupied in anything but pastoral pursuits. I am a farmer and live by the sale of my crops and stock, and I resent in as strong words as any respectable God-fearing man can the assertion that the old Pine Tree State is in the remotest degree "drifting into the condition of Ireland." Such balderdash makes the real farmer tired. If these grangers who sit in city offices and write compositions on something of which they have no conception would get out among the individual farmers they would learn something on the other side of the question.

Last summer deer wallowed my grass and even had the audacity to come into the garden and nibble the cabbages. At least twice during the summer my wife went out to shoo deer from the garden with her apron. In the early autumn they trampled my grain somewhat, and this spring they have had the cheek to drink sap from the buckets in our maple orchard. But we haven't made any claim for damages to the State, up to this time, and do not intend to.

Perhaps the entire damage to my farm last year, if carefully estimated, might amount to \$10 or \$20, and the 2 deer we ate last November and December amply repaid this sum. I know many farmers who look at the matter in the same light, and who say, with me, "Give us more deer; we can keep square and never violate the game laws."

We are sorry, however, for the suffering "farmers" of Androscoggin county, where deer are about as plentiful as crows in Boston. It is a measly shame to cut off those farmer's crops and drive their boys into the professions.

If you "sturdy farmers," who know as much about farming as my horse does about heaven, would get out into the fields and woods a while and absorb a little horse sense while getting good

air and learning something of God's creatures, it would do you good. You would then make grangers in a better sense of the word.

What is your opinion, Mr. Sporting Editor?  
—B. C. W. in Maine Paper, Somerset County.

#### SOME MISSOURI PORK.

Here is a clipping from a Chicago paper which will certainly interest you:

Oscar Long, of Nevada, Mo., recently killed 14 ducks at 4 shots. A year ago he killed 18 quails at one shot, only one of the latter getting away. They were bunched up at the root of an old peach tree.—Chicago Blade.

Will you please give this man what he deserves? He is a low mugwump, and any editor who would laud such a cowardly duck and quail hog is worse than the hog that drops on the quail when huddled beside a log to escape the winter blizzard.

A Sportsman, New York City.

I wrote this long bristleback, asking him if he had been correctly reported, and he says in reply:

The report you saw relative to my shooting is correct in every detail. If you care to use the matter, and desire a better picture of me, if you are willing to pay \$1 for the photo, as the editor of the Blade did, I will send you one of my good cabinet photos to use. I am not familiar with your magazine, but suppose you wish the best photo you can get.

Oscar Long, Nevada, Mo.

No, Oscar, I do not care for your picture. The fact that you sold one to the Chicago editor and that it was reproduced there, together with the record of your butchery, indicates that you are a shameless braggart, and I do not care to illustrate you. Bob Ingersoll used to say that there was no such place as hell. If he had lived to know you, he would have changed his mind. If there is not a literal hell, there must be some place a good deal hotter than the old orthodox hell ever could have been, for such brutes as you. Number 899 in the game hog pen is yours.—EDITOR.

#### IN SANTA BARBARA COUNTY.

Recently, while I was engaged at Miramar, a few miles from Santa Barbara, a large spike buck came tearing through the fields just below the Miramar cottages, crossed the railroad track, and plunged into the bay. Two young men who were near him reported him bleeding badly and his tongue hanging out. They watched him until he had swum out near the kelp, then lost sight of him. The next morning he was found dead on the shore below Miramar. I have since learned from Game Warden Able that it was one of 2 deer run by hounds owned in the foothills. Our county has a law

prohibiting the running of deer by hounds and the warden compelled the owner of the hounds to get rid of them. Santa Barbara has a large game protective association and among its members are some of the best people in the county. Game Warden Able is the right man for the place, and no guilty man escapes. This is a hard county to patrol, being over 100 miles long, with 2 ranges of mountains. We have one of the finest preserves in the State, on Guadalupe lake, 90 miles above Santa Barbara. The Guadalupe gun club has the lake leased for a term of years and enjoys some of the best duck shooting in the State, mostly canvasbacks.

Quail shooting in Santa Barbara county is good almost anywhere outside the city limits, and quails can be found by thousands in the Northern end of the county. There are plenty of deer, and the fishing, both trout and salt water, is all one can wish. Our hotels are good, and a visiting sportsman will always find a warm welcome in Santa Barbara county.

C. A. Loud, Santa Barbara, Cal.

#### ELK AT BIG PINEY.

In commenting on a letter in a recent issue of RECREATION, M. O. Newton says, in the March number, "No elk have been seen at Big Piney, Wyo., in 10 years, though there are a few 100 miles West of there, near the Park line." Mr. Newton is lost and should get out his map and compass. One hundred miles West of here is the Bear river country, and that is 130 miles Southwest of the Park line. He is also wrong regarding the elk. They were seen on every hillside in this region last winter, having been driven from the mountains by the deep snow. There are also thousands of antelope in this country. Our wardens are doing all they can to protect game. We have a few poachers, but they are being closely watched and will eventually come to grief.

Frank Bedier, Big Piney, Wyo.

If Mr. Newton will come out to my ranch, I will convince him that he is somewhat a "dreamer" himself. Elk are abundant here, though still weak after the privations of a long and severe winter; but this is no place for a man who wants to hog game. We propose to protect our elk to the limit and our wardens are wide awake.

J. E. Fredell, Big Piney, Wyo.

Mr. M. O. Newton, who calls Mr. DeKalb "a dreamer of dreams" for saying there are elk in Big Piney, is himself a veritable Rip Van Winkle. He should wake up and study the map. Big Piney is

in the heart of the elk country, and fully 10,000 elk enter it yearly.

Nimrod, Irma, Wyo.

NEW HUNTING COAT.

925,903.—Combination. Outer Garment. Frank Wilcomb, Norristown, Pa. Filed March 21, 1902. Serial No. 99,279. (No model.)



Claim.—1. A sleeveless shooting coat of skeleton form having strips to pass over the shoulders connecting the front and back sections of the coat, said coat having openings at the sides below the armholes to give ventilation and easy access to the interior of the coat, cross pieces to connect the front section and the back section, ammunition pockets in the front section, game pockets in said sections below the ammunition pockets, a game pouch on the inside of the back section accessible from the side and a game pouch on the outside of the back section open at top.

THREE WEEKS IN CAMP.

Last November I went to the Upper Peninsula for my annual deer hunt, with a party of 7. We took a new route and found plenty of deer, some bears, lots of rabbits, ruffed grouse, and few hunters. Near the railroad there were so many hunters, most of whom used high power rifles, that a man might as well go to war as to go hunting. One man fired at a deer, the bullet going through the animal and killing a man about 80 rods beyond. There should be a law prohibiting the use of high power rifles for game no larger than deer. The boys made fun of my old .38-40 Colt; they all had .32-40 smokeless and .40-82 rifles. I told them I could get rabbits for camp if nothing else. The first evening, in returning to camp when it was too dark to see my sights, 4 deer passed me at about 60 yards. On the 10th I killed a 201-pound

buck. The morning of the 13th, which was rainy and foggy, I was in a heavy thicket when I heard a noise like trees rubbing together. Then I saw a pair of antlers through the brush about 60 yards away. I fired, the result being a 4-point 189-pound buck. That made a pair hard to beat. The boys almost carried me on their shoulders that night. That far they had killed only 2 fawns. We remained in camp 3 weeks and got 10 deer in all, 7 of them bucks; and shot all the rabbits we needed, some grouse and a few gray squirrels.

O. P. Barber, Central Lake, Mich.

PATENT DECOY.

722,682.—Decoy. Henry S. Dills, Auburn, Ind. Filed June 16, 1902. Serial No. 111,982. (No model.)

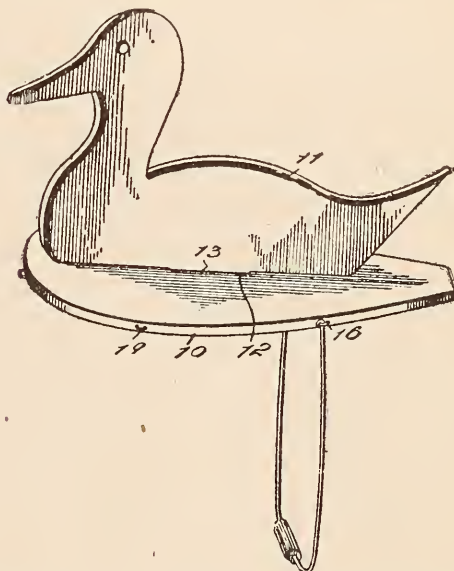

Claim.—1. A decoy comprising a float having a profile detachably connected therewith, and a balance comprising a weighted bail conforming to the outlines of the float and connected movably by its free end thereto, and means for supporting said bail in engagement with the float and in horizontal alinement therewith when said bail is not in use.

TRY A PAGE FENCE.

For some time I have been an interested reader of RECREATION and an ardent advocate of game protection as well, yet I am a law breaker in one sense. Deer are abundant here, and in some localities it is difficult to prevent them from destroying the crops. Residents of this section kill deer at all seasons, but while we are all guilty in this sense, hide hunting and other needless killing are not tolerated. What do you consider me? In the early days game was killed principally for food, and in this State many families depend largely on game for sustenance. When game becomes so scarce

that it must be protected to be shot for sport only, it should be protected perpetually. The pleasure derived from taking the life of a dumb animal is of a low order and is a relic of barbarism. When hunting is practiced for recreation, it should be with a camera only.

Oral Miller, Agnes, Ore.

ANSWER.

If you must kill the deer to protect your crops, the latter would not be entirely safe until all the deer were dead. That would indeed be a sad remedy. Your best protection would be a Page wire fence 88 inches high, which costs \$2 a rod. The deer can not see the top wires and so do not jump it. This fence is generally used in zoological parks and holds elk, deer, antelope, etc.—EDITOR.

SUGGESTIONS FOR PROTECTION.

I agree in part with E. G. Pettit, in February RECREATION; by all means shorten the open season. He speaks of the old much praised and much abused licenses. I think a plan I have conceived would not hurt the poor man, and certainly would not the rich, but would benefit both in that there would soon be plenty of game.

A license fee of \$1 should be charged every man who hunts out of his own county, and the dollar should be collected in every county other than his own. Have the money collected for license and for fines, say \$10 for evasion or negligence in obtaining license, spent in the introduction of game birds. Then protect the planted birds 5 years from first stocking. I would also welcome any other plan to protect and increase the game supply. With a law of this character men from the town who come to hunt with us farmers will get something besides fresh air; and their dogs, that have been trained and boarded at heavy expense, will get something besides curses and sore feet. I should like to see this discussed in RECREATION by members of the L. A. S., and farmers only.

D. D. Wakeman, Searsburg, N. Y.

GAME NEAR ARGENTINA.

Argentina game hogs have not yet butchered everything, so one can readily find places where the number of game birds bewilders one. With a .22 repeater I can easily get a bag of ducks or birds that resemble the quails and prairie chickens of the States. Storks, flamingoes, geese, gulls, hawks, owls and terns fill the air at times. After many hunts in the States when I would not get one shot a day, this country seems a paradise. The natives of the interior generally use bolas in hunting. The bolas are simply 2 or 3 balls of lead, each weighing several ounces, fastened together

with a rawhide thong. I have seen birds caught on the wing with them. From horseback the natives get ostriches, guanacos and llamas. These llamas are not unlike our antelope in size and habits. One can spend weeks in the pampas and see new birds or animals daily. The natives are too lazy to kill more than they need. The best outfit for general hunting consists of a shot gun and a good revolver. I have carried a .45 caliber Colt Army and find it all that can be wished for. I should like to read comments on the long range accuracy of the .38 Colt automatic.

H. J. Angle,  
Pehuajo, Argentine Republic.

145 DUCKS AT 8 SHOTS.

The Toms River, N. J., Courier of January 1, 1903, contained the following:

Forman Clayton and his 2 sons, with Mr. Andraise, killed 145 ducks in 8 shots Monday, 115 crow ducks and 30 redheads. The ducks were in an air hole in the ice, and all 4 gunners shot at once.

I wrote Forman Clayton as follows:

I am informed you and your 2 sons recently killed 145 ducks, 115 crows and 30 redheads, in one day. Will you kindly tell me if this report is true?

To this letter I received the following reply, signed by Capt. F. E. Clayton:

It is true we killed 145 ducks at one round, that is, one shot. I gave away all the wounded ones or we would have had 200. Plenty of men saw me kill them and helped pick them up. We came to the house, got horse and wagon and had the ducks at the house before breakfast.

I think you are a liar, but, if your story is true, you are a low, contemptible brute.—EDITOR.

DID NOT MOVE WHEN HIT.

A. B. Clayton wonders if other readers of RECREATION ever wounded a deer or moose mortally and had it stand motionless as if untouched. Five years ago last winter I was hunting on the East side of Columbia river, in Onion Creek basin, a few miles South of the British line. One day I was coming down a high mountain ridge on snowshoes. Reaching a small open space in the heavy timber, I saw a deer feeding in some bushes. The deer saw me at the same time and turned with his side to me. As I expected him to bound away like a flash I fired hurriedly, but he did not move. I reloaded, and, taking a little more time, fired again. As he remained standing, the distance being only about 100 yards and the buck a large whitetail, I thought it strange I could not hit him. I fired a third time, and down he went. The

hillside being steep, the deer slid about 150 yards below where he fell. Every one of the 3 shots went through the animal's body in a vital place.

T. R. Gilden, Spangle, Wash.

#### PREDICTS EXTERMINATION OF ELK.

The past year was a good one for game, ducks, geese and quails being numerous. There are many chickens in the high hills. Deer, elk and bear have suffered a great deal during the past 2 years from the Thunder mountain excitement, which has filled the mountains with a swarm of prospectors who are not disposed to regard the game laws when meat is scarce and a fat buck within range. The last game law passed by the late Legislature is good in all except 2 respects: those which permit the selling of trout and the killing of female elk. A grave error was made in removing the sex restriction on elk. This noble American deer is rapidly approaching extermination, and unless immediate steps are taken, another decade will witness the destruction of the last herd. Mountain sheep are also growing scarce, though last autumn, while deer hunting in the Deadwood country, I heard of a bunch of 10 which had been driven down from the high mountains by forest fires.

J. H. Gipson, Caldwell, Idaho.

#### TWO HUNTS FOR A LION.

Last winter I had a line of traps on Hot Spring creek. One morning I found that a large mountain lion had got into one of my No. 4 traps and had broken the chain and escaped. There was not much snow in the creek bottom, and it was difficult to trail him, but I went home after my father and together we put in the day trying to track him. We made slow progress and when night came we were only about 2 miles from where we started; but the lion was getting on to higher ground, where there was more snow, so it was less difficult to follow him. However, as the trail seemed to be 2 or 3 days old, we became discouraged and gave it up for the time.

Four days later my father got Mart Bright to go with him and about noon they struck a fresh trail. As they had a good dog, they soon had the lion up a tree, where they shot him without any delay, strung him on a pole and carried him out.

Herbert W. Lord, Darby, Mont.

#### GAME NOTES.

Polk township, principally old slashings and windfalls, is grown up with blackberries and wild cherries, through which it is almost impossible for a man or dog to go. Snow was about 8 inches deep, and we had 2 young fox hounds and a water spaniel that had never been on a wildcat's trail

when we hunted there last winter. The first afternoon the dogs drove a wildcat into the rocks. We set some traps we had with us and returned to the farmhouse. Next morning we found one cat in a trap and killed it, and shot 2 more in the afternoon. The last one weighed 53 pounds.

In the county where I live grouse and quails were formerly abundant, but every fall hunters from Pittsburg come with dogs and kill all the game. They come the first of the season, and by the time local hunters can get out, all the grouse and quails are killed. We would like to know how this can be stopped.

Jesse Snyder, Pierce, Pa.

We see so much published concerning the killing of game out of season by the crews in lumber camps, that I should like to call attention to a case, on the credit side of the account. It is only of late that moose have begun to return in any numbers to Southwestern New Brunswick. Five years ago a moose track was an uncommon sight, where moose are now fairly numerous. Last winter 9 yarded within 3 miles of a camp where there were 30 or 40 men, and though rifles were handy not a moose was killed or even shot at. The boys jumped them several times, "just to see them run through the snow," as one of them told me. During last summer I was in the same country and saw a number of moose; bulls, cows, calves and yearlings. Signs were numerous everywhere. The few inhabitants there are seem to take an interest in game protection.

Gardner Cornell, Providence, R. I.

In December RECREATION Dr. S. B. Keith, of Palmer, Mass., says game was never before so scarce in Massachusetts as it was the past season. In Berkshire county birds have not been so plentiful in 10 years as they are this season. He gives the reason of the scarcity as too many hunters and foxes, and says that 2 years ago a man with one fox terrier got 87 foxes. A good year for foxes! They must have thinned out terribly, for the Springfield Republican told of the annual hunt in Palmer, in which the Doctor took part, and they only got 2 foxes. Perhaps they did not have the fox terrier, or the Doctor may be holding them back for the bounty.

W. J. Cross, Deputy, Becket, Mass.

Enclosed find clipping from our morning paper:

C. M. McIntosh, a rancher, living about 10 miles East of Great Falls, was seriously injured yesterday morning by the accidental discharge of a gun which he was handling. In holding his gun he rested it on the ground and held the muzzle in his left hand. In making some sudden

movement his knee struck the hammer, released it, and the weapon was discharged. The full charge went through the fleshy portion of his left hand, between the thumb and index finger, and passed within 2 inches of his head.—Great Falls Tribune.

What could this man have been hunting? Too bad the charge did not go closer to his head. Hunting out of season I regard as worse than being a game hog.

C. S., Great Falls, Mont.

I was interested in Mr. Smith's inquiry in regard to boots. I bought a pair of leather boots, the kind that lace up the front and side, and had a shoemaker put tops on so as to make them hip boots. They have been in use 2 years without leaking, and I believe they will last another 2 years. I have used them for both hunting and fishing, going in water clean to the tops hours at a time, but have kept my feet perfectly dry. They are far superior to rubber boots, as they do not gall or sweat the feet. Of course, one must take good care of them. I rub mine over with melted lard every time I come home, and they are always soft as kid.

R. W. L. Baco, Chicago, Ill.

I am back in the mountains 25 miles East of Butte, the great copper camp. Within sound of Butte's whistles are plenty of bears, deer, mountain lions, lynxes and moose. Even thus near civilization are jungles equal to any found in Africa and where man has never set foot. I have traveled over many parts of the Rockies and have never seen any place so weird and so seldom visited by man. I ran on to 2 large lynxes last February and killed both at close range with my Savage .303, fitted with a 20-power telescope. That is the only thing for me, as my sight is failing from long continued underground mining.

H. J. Humphrey, Boulder, Mont.

We notice how you roast the game hogs in RECREATION. We think a man has a right to kill as much game as he pleases. One day last December we killed 193 ducks in 5 hours; mostly big ducks. There are no bristles growing on us, either, that we can see.

J. R. Casey,  
D. J. Hogan,  
P. C. Dunn,

Ashland Ore.

I think you are all liars. I would not believe a man under oath who would make such a statement as yours.—EDITOR.

I disagree with Dr. S. B. Keith, who says Massachusetts game was never so scarce as at present. Ruffed grouse, quails, rabbits and hares are more numerous than for

years. I never before heard of a man's hunting foxes with a fox terrier. Hunters here who have good dogs are lucky to get one fox a week; some get no more than one each season. We are not all doctors or lawyers. I wonder Dr. Keith does not hunt foxes himself if they are so abundant about Palmer.

F. W. Stephenson, New Bedford, Mass.

Annihilation threatens one of our most attractive woodland creatures, the squirrel. Since the use of his fur has become so general in our country, hundreds and thousands of these little fellows have been slaughtered that would not otherwise have been molested. We should do all we can to discourage the use of this fur as an article of merchandise.

Jacob A. S. Roger, Dayton, O.

Here is a claim from the game haunts of Northern Michigan, where I killed a buck last fall that was cousin to the mule deer. Its ear measure 5 inches wide and 7 inches long. Can any one beat this for a Michigan deer? I have the head mounted.

A. A. Hathaway, Alba, Mich.

R. L. writes RECREATION that game is scarce on the Montana range, whereas the fact is that it is more abundant than he claims. Assiniboia is fairly well stocked with game of all kinds, although game hogs are numerous there, too.

S. E. Sangster, Port Perry, Ont.

Have you a good place to put your gun when you are not using it? If you have not, why not get one? If you have, why not get a still better one? Nothing could be more suitable or attractive for holding a gun than the little rack, made of buffalo horns, which I offer as premium for 5 yearly subscriptions to RECREATION. The buffalo horns are souvenirs of a most interesting animal now extinct except in private preserves, and when the rack is on the wall it makes of the gun a handsome decoration, instead of a nuisance in the house. Send me 5 subscriptions and earn one of these gun racks.

RECREATION is the only true sportsmen's journal in the country, and in thanking you for the stand you have taken against game hogs, I know I am voicing the sentiment of all true sportsmen. May the good work go on until the hogs' bristles are all worn off with the friction of sound sense.

W. F. DeMorest, Leslie, Mich.

RECREATION is my book of faith and my guide in the woods and fields.

A. S. Trude, Chicago, Ill.



## FISH AND FISHING.

### ALMANAC FOR SALT WATER FISHERMEN.

The following will be found accurate and valuable for the vicinity of New York City:

Kingfish—Barb, Sea-Mink, Whiting. June to September. Haunts: The surf and deep channels of strong tide streams. Baits: Blood worms, shedder crabs and beach crustaceans. Time and tide: Flood, early morning.

Plaice—Fluke, Turbot, Flounder. May 15 to November 30. Haunts: The surf, mouth of tidal streams. Baits: Shedder crabs, killi-fish, sand laut. Time and tide: Ebb, daytime exclusively.

Spanish mackerel—Haunts: The open sea, July to September. Baits: Menhaden, trolling—metal and cedar squids.

Striped Bass—Rock Fish, Green Head. April to November. Haunts: The surf, bays, estuaries and tidal streams. Baits: Blood worms, shedder crabs, Calico crabs, small eels, menhaden. Time and tide: Night, half flood to flood, to half ebb.

The Drums, Red and Black. June to November. Haunts: The surf and mouths of large bays. Bait: Skinner crab. Time and tide: Day, flood.

Blackfish—Tautog, April to November. Haunts: Surf, vicinity of piling and old wrecks in bays. Baits: Sand worm, blood worm, shedder crabs, clams. Time and tide: Daytime, flood.

Lafayette—Spot, Goody, Cape May Goody. August to October. Haunts: Channels of tidal streams. Baits: Shedder crabs, sand worms, clams. Time and Tide: Day and night flood.

Croker—July to October. Haunts: Deep channels of bays. Baits: Shedder crabs, mussels. Time and tide: Day, flood.

Snapper—Young of Blue Fish. August to November. Haunts: Rivers and all tide ways. Baits: Spearing and menhaden; trolling pearl squid. Time and tide: Day, all tides.

Sheepshead—June to October. Haunts: Surf and bays, vicinity of old wrecks. Baits: Clams, mussels, shedder crabs. Time and tide: Day, flood only.

New England Whiting—Winter Weak-fish, Frost-fish. November to May. Haunts: The surf. Baits: Sand laut, spearing. Time and tide: Night, flood.

Hake—Ling. October to June. Haunts: Open sea surf, large bays. Baits: Clams, mussels, fish. Time and tide: Day and night, flood.

Weak-fish—Squeteague, Squit. June to October. Haunts: Surf, all tideways. Baits: Shedder crabs, surf mullet, menhaden, ledge mussels, sand laut, shrimp. Time and tide: Day and night, flood preferred.

Blue Fish—Horse Hackerel. June to November 1st. Haunts: Surf, open sea and large bays. Baits: Menhaden, surf mullet and trolling squid. Time and tide: Daytime; not affected by tides.

### A TRY FOR 'EM.

One day last summer I got my rubber boots, fishing tackle, etc., together, jumped into my buggy and drove 12 miles down the river to a favorite stretch of water, to try for black bass. Putting together my handsome little 5 ounce split bamboo rod, I mounted reel and line. At the end of the line, on a 6 foot leader, I put one of the little fly spinners that are hand-made by John J. Hildebrandt, Logansport, Indiana. This was to be my first try with a Hildebrandt fly spinner. Testing my tackle, to satisfy myself there was no fault with it, I

stepped quietly into the water, my pulse at the time 120, later out of reach of figures. I waded cautiously down stream about 10 yards, and getting out sufficient line, I made my first cast, toward a likely looking pool, with the anxiety known only to the real angler. Slowly I drew the magic little twirler toward me, waiting, watching, almost breathless from suspense. Nothing doing!

My next cast was between a large boulder and a bunch of water weeds, some 3 or 4 feet from the rock. My cast was as accurate as I could wish, and my line straightened! Electric thrills chased up and down my spine, and the battle was on. Only a moment was required for me to know that I had an impatient patient on the little fly spinner, and that I should need all the knowledge and skill acquired by years of practice, backed by trusty and well tested devices, if I should successfully manage this madly wild, cavorting, plunging, tricky, courageous, animated and concentrated bundle of lightning and dynamite combined, this veritable Jim Jeffries of our streams.

His lordship tried every trick known, and they are many; a mad plunge for a large rock, then a frantic dash for the weeds, next a whirlwind dive to reach a sunken log, followed by a rush across the stream, back and forth, up stream and down stream. In and out of the water, flashing like a meteor, his royal highness continued his ever changing tactics, trying to gain his freedom. After what seemed an hour to me, though in reality it was only about 7 minutes, he slowly and sullenly surrendered. The little Hildebrandt fly spinner, backed by the steel like toughness of my rod, was too much for him. He weighed 2 pounds and 14 ounces; not a monster in size, but all of a Jeffries in fighting ability.

In the next 2 hours this was repeated 4 times, though the fights were not so long, for my first bass was the largest by a pound. The contests were, nevertheless, full of excitement, and 5 bass in a little over 2 hours, in a stream where bass are scarce, is a record to be proud of.

Dr. J. C. Adkins, Marion, Ind.

### TWO NEW NETS.

723,484.—Landing Net. George Paley, Preston, England. Filed October 16, 1902. Serial No. 127,600. (No model.)

Claim.—1. A landing net comprising a spring hoop on which the net is hung, a socket with separate holes to receive the

ends of the spring hoop, and means for locking the hoop in an extended position.

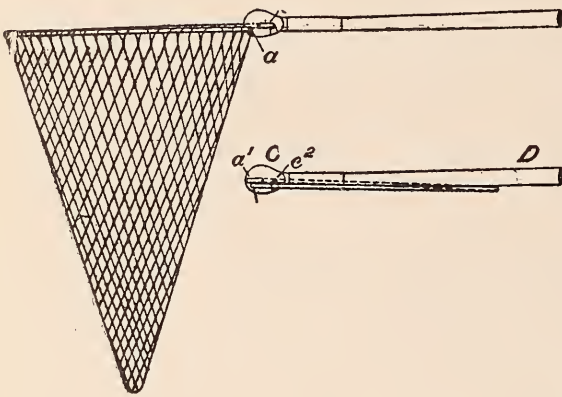

2. A socket with holes into which the ends of the hoop pass in opposite directions, a crank loop on one end of the hoop, and a hole with which it engages when the hoop is extended to lock it in position, substantially as described.

25,962.—Minnow Net. Sylvester W. Higgins, Detroit, Mich. Filed June 18, 1902. Serial No. 112,136. (No model.)

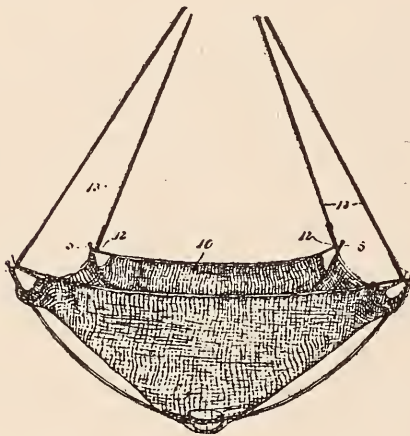

Claim.—1. In a minnow net, the combination of a frame consisting of radial arms, a net or fabric secured to the outer ends of said arms, rings on the ends of said arms, and cords attached to the edges of said fabric at a distance from its points of attachment to said arms and passed through said rings.

#### NIBBLES.

Dr. F. B. Rose, a dentist, and his brother William, both of Franklin, N. Y., recently took 80 trout in one day from East Handsome brook. The fact is admitted in the following letter:

You ask information in regard to trout which my brother and I caught. In a way you were correctly informed. We were not together, however; each went a dif-

ferent way, but strangely enough at night we each had 40 trout. It is seldom I get a chance to go fishing. Have not been before in 2 years. Most of my catch went to the sick and invalids about town.

F. B. Rose, Franklin, N. Y.

Your excuse that you gave the fish to the sick and the invalids is fishy. As a rule, doctors do not allow sick people to eat fish of any kind; in many cases they specially forbid it. You realize you have made a hog of yourself and are trying to escape the disgrace you have brought on yourself. Your number in the fish hog register is 900 and that of your brother is 901.—EDITOR.

What kind of flies are best for white perch fishing, and where can I get them? What other bait is suitable for perch fishing?

A. La Coanet, Philadelphia, Pa.

#### ANSWER.

Any small artificial fly will do fairly well for use in white perch fishing. They can be obtained at any store supplying such tackle. Light flies on darker days and dark flies on brighter days, of course, will prove best. However, if you really wish to catch white perch, there is nothing superior to the ordinary angleworm. Perch take them readily at all times.—EDITOR.

F. B. Pingree and J. W. Buemond went to Windham and caught 80 trout.—Bellows Falls, Vt., Paper.

In regard to above, Pingree has this to say:

In reply to your letter will say that 2 of us caught 82 brook trout in the town of Windham, fishing 5 hours.

Fred. Pingree, Bellows Falls, Vt.

Your name is hereby entered in the game hog book No. 902. That of your friend Buemond is No. 903.—EDITOR.

A friend and I recently fished in North river, which flows into Shoalwater bay in Northern Washington. Though it was immediately after a long rainy spell, the fish bit ravenously. I believe they would have bitten at sour apples. The first fish that struck my bait took the hook and several yards of line with it. We caught 36 salmon trout in a few hours.

Charles Cole, Fairhaven, Wash.

I have just returned from a fishing trip at Wamsly lake, near Livingston Manor, Sullivan County, New York. The fishing is good. All brook trout. My largest weighed 2¼ pounds.

H. B. Riserdorph, W. Troy, N. Y.

## GUNS AND AMMUNITION.

Anybody can shoot all day, but a gentleman will quit when he gets enough.

### SEEKS INFORMATION.

Last fall I bought a No. 1½ grade Ithaca shot gun, and have had no cause to regret my choice. The gun is a beauty, shoots well and being made to order, is just the right fit. I intend to buy a rifle, and have almost decided on a Savage, .303 caliber. I want the rifle for small game, with now and then a deer or bear. Is there a rifle made to fulfil these requirements, using cheaper ammunition than the Savage? Or can shells be reloaded to make them cheaper and just as good?

Will your readers enlighten me on the following subjects: Would a \$10 No. 24 Sidle telescope be a desirable feature on a Savage hunting rifle? Or would a Lyman rear combination and ivory front be a better sight? What about paper patched bullets for hunting? Are they used with smokeless powder? Who makes a belt for these cartridges? In molding bullets 10 to one, are the parts proportioned by weight or bulk? What is a wind gauge sight and its advantage? What are dense powders? How is a 25-pound pressure determined on gun wads? Is a 25-pound weight placed on the rammer when wad is placed in shell, or is same weight dropped one foot? What is the best shot gun black powder? Does coarse powder burn slower and stronger than fine? What constitutes a good hunting knife? What does a good compass cost, and what is meant by a stop to same? What is the range, velocity, and penetration of the 32 short Harrington & Richardson revolver with 5-inch barrel? Are these shells reloaded with good results?

In my 12-gauge Ithaca I use U. M. C. Magic shells, 2¾ drams powder, 2 B. E. felt wads between 2 card wads and 1½ ounces shot, with card wad and good crimp.

Thos. Ford, Boston, Mass.

### ANSWER.

A .303 Savage would come as near meeting all your requirements as any rifle on the market. The miniature cartridge would be all right for short range target work and for small game at short range, while the full charge cartridge would be good for anything from a fox up to a moose. There is no rifle on the market that would give this combination and that uses cheaper ammunition than the Savage.

I never advise anyone to reload rifle shells. Many people do it and get fair results, but on the other hand unless a man

makes a careful study of it and devotes a great deal of time to the work, and has a complete and somewhat expensive outfit for it, he can not get the best results. The machinery used in the large cartridge factories for reloading shells costs many thousands of dollars, and is absolutely accurate. It is, however, better to buy reloaded ammunition, even at the difference in price, than to load shells yourself and occasionally miss a fine animal by having a bullet seated slightly out of line in the shell.

Such a telescope as you mention is all right for target shooting and for small game about home and in the fields, but is not practicable for rough usage in the woods or in the mountains. It is delicately constructed and is liable to be knocked out of line. I should prefer the other combination you refer to.

Paper patched bullets are not necessary in modern rifles using smokeless powder.

There are several forms of wind gauge sights on the market, but they are intended only for long range target shooting, and are not practicable for hunting purposes.

Get a catalogue of hunting knives from the Marble Safety Axe Company, Gladstone, Mich., and select from it the knife that pleases your fancy. They are all good and you will scarcely make a mistake in buying any one of them.

This company also makes compasses, and if you will write them they will give you full information regarding the use of them.

—EDITOR.

### SMALL BORE RIFLE.

Regarding the communication from A. J. Hubbard, color sergeant of the 23d Infantry, N. Y. N. G., in RECREATION for January, the United States is to be congratulated on possessing such a fine rifle of American make, as heretofore it has favored foreign arms and those not of the best make. Sergeant Hubbard mentions 44-grain charges, but does not say what kind of powder is used. I assume it is Du Pont .30-Caliber Military. I have shot 42 grains of this powder in my Mauser and in a Remington-Lee 7 mm. sporting rifle regularly without damage. Sergeant Hubbard says the Krag is not strong enough to stand this heavy charge, but that the breech bolts were broken. The Krag has only one locking lug on the breech bolt. It is the 7 mm. Mauser that has 2, and the Remington-Lee

has 4 locking lugs on the breech bolt. I do not think that charge would have injured a Mauser, although I understand the 220-grain would increase the breech pressure. In 1898, in a series of experiments at Frankford Arsenal, with a 7 mm. Mauser rifle and German ammunition loaded with Troisdorf powder, a breech pressure of over 60,000 pounds a square inch was developed in the powder chamber, the velocity being about 2,300 feet a second. Du Pont .30-Caliber powder gave the same velocity and a pressure of 44,000 pounds. The sergeant says the rimless shell is to be adopted for the new rifle. This is essential for heavy charges of smokeless powder. I have fired hundreds of 7 mm. Mauser shells and never knew one to burst in the middle, leaving a part in the chamber. The second time I fired a new Savage rifle the shell broke in the middle, part of it remaining in the chamber, rendering the gun useless for the time being. This is not peculiar to the Savage, but is characteristic of any rifle using rim headed cartridges, loaded with high pressure powder. A theory of mine is that the cartridge is held by the rim and unless the shoulder of the shell fits the shoulder of the chamber snugly, the strain is so great that the shell is pulled apart. With the rimless shell the breech bolt presses firmly against the base of the shell and forces it against the shoulder of the chamber, so that stretching is prevented. I have, however, known these shells to give out at the muzzle. The 7 mm. cartridge is my favorite. Out of 26 small bore rifles in use, in only 2 does the total weight of cartridge exceed that of the 7 mm. cartridge, the Martini-Metford, 287 grains, and the 8 mm. Mannlicher, 286½ grains. The bullets of these rifles weigh about 225 grains and 7 mm. 175 grains, a difference of 50 grains in the bullets and only 5 and 4½ respectively in the whole weight of cartridge. As the difference is largely in the powder charge, it can readily be seen where the 7 mm. rifle gets its tremendous velocity and penetration; and, when soft point bullets are used, its shocking and killing power.

L. H. Higgins,

Master S. S. Admiral Sampson.

#### THE SAVAGE ABOVE ALL OTHERS.

Reading RECREATION regularly and being somewhat of a gun crank, I take great interest in the guns and ammunition department. Like many others, I have gained good information from that department, but in it occasionally see things to which the majority of fair-minded sportsmen must take exception. W. A. Cone's article, in March RECREATION, "Jammed the Sav-

age," especially provokes me. The point in his case seems possible but improbable and highly incredible. Have handled a great many shells of the bottle-neck variety, and as the body of the shell tapers from the head toward the bullet and the bullet itself is of a yielding nature, I doubt whether the cartridge could not be extracted more easily than jammed, even if it were possibly larger than the chamber in the barrel.

Moreover, the shells used by Cone were probably drawn up with the regular set of dies, and it being impossible for any great variation to exist in the size of the finished shells, I am tempted to regard his experience as caused by circumstances which he has failed to state properly.

Never yet has it come to my knowledge that a bottle-neck shell, whether manufactured by the Savage, Winchester, U. M. C. or any other reputable concern, jammed unreasonably in the chamber for which it was intended. On one occasion, in displaying the rapid action of my Savage .303, I jammed a Winchester .30-30 quite hard in the chamber, but pushed it out easily in a few minutes with a wooden cleaning rod without visibly upsetting the soft lead bullet.

The Winchester is a good and efficient rifle; so are others; but the Savage is above them and has no points in common with them. We would not compare a shot gun with a Maxim-Nordenfeldt machine gun, or in a lesser sense compare a hammerless safety or bolt-action rifle like the Savage, Mannlicher, Mauser, Lee-Remington or Krag-Jorgensen with the antiquated hammer variety, of which the Winchester is a prominent type. A number of guns are good enough; the part of the combination lacking quality usually is the man behind the gun. I use a Savage .303 and I have no fault to find with it.

I was also interested in Mr. Cone's account of his hunting trip to Nova Scotia after moose. Passing the question of necessity or advisability in locating 38 miles from any settlement before trying his new rifle for range, accuracy, etc., I ask whether it is a custom among pilgrims to that section to select such remoteness, and if so, what about the trials and tribulations in toting moose or deer 38 or 40 miles through such country as Northern Maine and adjoining provinces?

J. D. Tymon, Salem, Mass.

#### THEY LIKE ROBIN HOOD POWDER.

In the gun and ammunition department of April RECREATION, I note 2 inquiries which interest me. One is from A. W. Crampton, St. Albans, Vt., the other from

A. B. Turf, Pittsburg, Pa. To both I say, shoot Robin Hood smokeless powder. In my travels over this district as a special game warden I have met disgruntled sportsmen everywhere, who were shooting various brands of powder at geese and ducks. Some of these men claimed they could not get a smokeless that would kill. I filled my shooting coat pockets with shells, loaded with the 3 leading brands of nitro powders, and went out to show the boys how to do it, but out of 16 easy shots I got only 4 geese, the closest falling nearly  $\frac{1}{2}$  mile away; so I joined the black powder brigade.

Shortly after this I saw the Robin Hood advertisement in RECREATION and wrote the company to send me a case of shells that would kill geese, if there were such. When the shells came we were so dubious about them that we shot them all away at targets, and could scarcely believe the evidence of our eyes. We bought special hand-loaded shells, loaded with various nitro powders, and tested them with the Robin Hood, to be sure we were right before pinning our faith to the latter. When I say the Robin Hood is the best powder we ever shot, it does not convey one-half our appreciation of it. To be more definite,  $\frac{3}{4}$  drams of load: 10 to 12 grains, by weight, Du Pont Robin Hood will put every shot through an inch soft pine board at 40 measured yards. The same load will put as many shot in a 24-inch circle at the same distance as a corresponding load of any other powder, black or nitro, will in a 30-inch circle. Robin Hood is not a nitro, but is cheaper than any and cleaner than the best. I write this because we have found the makers of that powder straight men. Theirs are the only smokeless shells handled as stock shells by the hardware dealers of our city, for they can not sell anything else. By "we" I mean 46 sportsmen of this city and vicinity who have made a special test of these shells for penetration and pattern.

Long life and the best of everything to RECREATION and its fearless editor, who has re-created many good men out of poor game hogs.

W. W. Tesch, Lexington, Neb.

In answer to A. W. Crampton, St. Albans, Vt., re Robin Hood smokeless powder shells, I have used the shells in question ever since they were put on the market, and always found them quick and reliable. As to pattern and penetration, they have no rival.

W. L. Cameron, Ottawa, Can.

#### PAPER PATCHED BULLETS.

In February RECREATION, G. L. W., Pasadena, Cal., asks for experience of those

using paper patched Savage cartridges. Last year I used several hundred paper patched cartridges in my .303 Savage, and found them, for small game and medium range target practice, much superior to other cartridges. At 100 or 200 yards the paper patched bullet will give much closer grouping than any other I have used. With a little care every bullet can be put inside a 21 inch circle at the distances mentioned.

The charge I have used most is a 155-grain bullet, and 15 grains powder, either Savage No. 1, 1901 brand, or Du Pont .30 caliber smokeless. I can see no difference between them when using that or a slightly heavier charge. Lately I have been using a 162-grain bullet and 20 grains powder. The latter cartridge gives a slightly increased velocity and flatter trajectory, but while just as accurate, is no improvement over the lighter charge for hunting small game or target work.

The 155-grain bullet and 15 grains powder is a more powerful load than most of the 32 or 38 rim fire cartridges on the market.

The bullets are cast in an Ideal cylindrical adjustable mold. I also add a small quantity of zinc, say one part in 50 or 75, to the one to 10 mixture. That makes a harder and smoother bullet and one less liable to lead the barrel. Use thin patch paper, put it on damp and allow it to dry thoroughly before seating. If shells are not new they should be resized. Each charge of powder is weighed. I have never yet been able to get a measure that would dip exactly the same quantity each time, no matter how much care was used. Bullets are sealed within Ideal No. 3 special reloading tool, and not crimped. Each bullet is well lubricated by dipping twice in a dish of melted lubricator after being sealed.

The gun and ammunition department is a constant source of pleasure to me, and I get many valuable hints from it; but I feel that all things should be thoroughly tried and known to be good or bad before being reported in it.

F. H. B., M.D., West Pawlet, Vt.

#### CRITICIZES MODERN GUNS.

I have an old 38-90 Winchester single shot rifle which has killed many antelopes since I first came to Texas in 1883. I reload my shells; in fact, I generally buy the empty ones and load them to suit myself. Sometimes I use 255-grain solid bullets and again hollow express bullets. I load with coarse powder, Du Pont Chokebore, 5 or 7, as it gives better results. I use a buckhorn rear and an ivory front sight. Both have been filed down until I know just how the rifle will shoot. With 5 cartridges in my

left hand, I can shoot as fast as I want to if the game is in sight, and have killed antelope at 800 yards with shells I loaded myself. I would not be afraid to meet old Ephraim himself. The new smokeless rifles are all right, but look at the high front sight. How different from Sharp's Old Reliable buffalo gun! How is one to judge the distance? The average soldier should never have a repeating rifle; he wastes too much ammunition. Why does not Uncle Sam adopt the Winchester single shot with the Sharp's solid breech action? Compare it with the clumsy Mauser with a rear sight sticking up like a sore thumb, and the Lee straight pull with half a cord of wood, a bolt fit for a burglar-proof safe and the front sight like the business end of a butter knife. If Uncle Sam is going to adopt a shooting iron, why does he not select one that will make his boys look like soldiers and not like pick-and-shovel men? Modern rifles have about as much form as the old fashioned muskets which Uncle Sam bought from Austria during the civil war.

For small game I have a Stevens Ideal No. 44, .22 caliber, long rifle, one of the most accurate target rifles made. I also have a Henry Richards, London, England, 12 gauge, 9-pound hammer gun with 34-inch barrels. I have fired 5 drams of black powder in it and the barrels are as clean and bright as when I bought it in 1885. Any gun made by a reliable man is good, but a gun is like a watch, it must be kept clean to do good service.

El Capitan, El Paso, Tex.

#### LOADS AND TRIGGERS.

H. J. F., Providence, R. I., says he has a 16-gauge Ithaca that did not shoot strong enough to suit him. He wrote the makers, and they told him to use  $2\frac{3}{4}$  drams powder and  $\frac{7}{8}$  ounce shot. He did so and "noticed a remarkable difference." Just what that difference was he does not say, but I can imagine, for I, too, have a 16-gauge Ithaca. The record tag said the left barrel threw 310 shot in a target. It would not do so for me, so I wrote the company. They said to use  $2\frac{1}{4}$  drams powder and  $\frac{3}{4}$  ounce shot. That proves the best load I can put in. Even  $2\frac{1}{8}$  drams powder will throw  $\frac{7}{8}$  of No. 4 shot through  $\frac{3}{8}$  inch of white pine at 35 yards and group them close enough for ducks or chickens. This ought to be an effective load for such birds even at 60 yards, and a 10-year-old boy can stand behind it. In loading shells for drop or soft shot, I use a trap wad next to powder, then a  $\frac{3}{8}$ -inch felt under an ordinary block edge. I have come to prefer a round crimp; all the best patterns I have

made came out of round crimped cases. A good wadding for light charges of powder is a split salmon wad, 2 block edges and an A cord wad. Where more powder is used under soft shot, a softer layer of wadding will prevent the quick explosion of nitro from battering the shot. If H. J. F. uses  $2\frac{3}{4}$  and  $\frac{7}{8}$  and hard wads he may injure his gun.

Sometimes a charge may appear slow when it is really quick. This is caused, in some cases at least, by the trigger creeping or springing back a trifle before releasing the hammer. The shooter ceases to follow a flying bird with the gun when he presses the trigger. Then the trifling delay in the fall of the hammer is enough to cause him to shoot behind.

Let H. J. F. and others look for the cause of their troubles in the creeping of triggers, and use a moderate load.

K. A. W., Watertown, S. D.

#### TO LOAD 30-30 SHELLS.

I find in RECREATION many ways of loading shells for .30-30 and .303 rifles. I have loaded many of these shells within the past 5 years. I hunted with a .30-30 2 years and found it a good shooting gun, with this No. 2 rifle powder and Ideal bullet, 3082, 150 grains.

The action of the .30-30 bothered me sometimes, so I sold it and bought a Savage .303. I have loaded shells for this gun, using 8 to 10 grains of Du Pont No. 1 rifle powder and the miniature bullet, .311-100-grain weight; also the Ideal bullet, No. .311207. These loads are good up to 100 yards and for small game. The best load for a .303 is equal parts of black powder, Du Pont's fig. and Du Pont's shot gun powder, smokeless, mixed. Use 20 grains, black powder measure, for a load and a 32-35-165 bullet, cast slightly larger than .311, but sized down to .311 easily. Any tool which will seat the full jacketed factory bullet will seat this bullet to perfection. The bullet should not be softer than one in 12. A little over an ounce of tin to a pound of lead is about right. I have never had a shell break and I have shot some of them 20 times. I use sawdust to fill the space between powder and bullet, but I do not think it necessary. I hope RECREATION readers will try this load.

The other day I bought a so-called sportsmen's magazine, and it contained pictures of "sports," with great strings of fish and others with bushels of ducks. The editor did not have sand enough to roast them, which they deserved. They know better than to send their photos to RECREATION.

Fred Andrus, Chicago, Ill.

## TRY COLT'S.

Has anyone seen the Mauser and Luger automatic pistols used together, so that a comparison as to action, killing power, penetration and range can be made? I should also like to read in RECREATION some experiences as to the accuracy of the .25-35 Winchester. I intend buying one of the pistols, and wish to get the best.

F. H. Scott, Philadelphia, Pa.

## ANSWER.

I know of no one who has made such tests as you mention of the Mauser and Luger pistols, so can not answer your question. I shall, however, be glad to print it in RECREATION, and it will no doubt call out some replies.

I have printed articles in RECREATION regarding the accuracy and effectiveness of the 25-35 Winchester. If you have a file of the magazine you can look up these letters. If not, I can supply you with back numbers or bound volumes.

I advise you to examine and test the Colt automatic pistol before buying either of the others. In my judgment it is a much better weapon. It is much simpler in its mechanism, it is neater and more compact in form, and much more pleasing to the eye. I placed one of these in the hands of an army officer who is an expert in small arms, and he made a strong report on it: The fact that the Ordnance Board of the United States Army has adopted this pistol for use in the army, and that it has bought and issued a large number of these weapons to the troops, is a strong endorsement of it.

Strangely enough, the Colt people do not advertise in RECREATION, but all the same I believe they make the best automatic pistol in the world.—EDITOR.

## KILLING POWER OF THE 30 CARBINE.

In reply to H. W. Frost's inquiry regarding the killing power of the Winchester 30-30 carbine, will say that I killed 2 deer last fall with one. The first, a 4-pointer, was hit in the neck between the spine and the skin, at 150 yards. He went down partly paralyzed, but soon jumped up and ran 20 feet, when a bullet through the left shoulder, cutting a large artery and coming out behind the right foreleg, killed him. The heart was not touched, yet the buck expired after a few kicks.

Another deer, a small spike, dropped like a rock when hit, at 60 yards, in the spine above the shoulder. The bullet came out under its left foreleg.

The striking power and penetration of the carbine equal that of the rifle except perhaps at extreme long range. You can not expect to put a grizzly to sleep by a bullet in his hind leg with any rifle.

Have met several men who claimed to have killed deer by head shots at 100 and 150 yards with the 22 W. R. F. I do not think this improbable, considering the wonderful penetration and accuracy of the little cartridge.

Some portions of this State are veritable pens of game and fish hogs which thrive under inefficient wardens. The laws are all right, but there are few who enforce them to the letter.

Edw. Pickersgill, San Francisco, Cal.

## SAVAGE SHOOTS LIGHT LOAD.

Those who say the Savage 30-30 will not shoot a light load accurately are mistaken. I send a target to show the regularity with which the Savage throws the Kephart bullet with 10 grains of powder. To hold the grooves the bullet must be 1-10 tin. Use any primer that will fit the shell.

I have used the same load in the 30-30 Winchester with equal accuracy; also in the 25-35 Winchester. Now I am using 10 grains of powder behind the 165 grain pin lead bullet in the 32 special, which equals the full load of black powder. I also use Ballastite.

I should like to see something from any one who owns a 32 special Winchester. I find it perfection for range, accuracy and killing power.

The light loads are excellent for rabbits, squirrels and coyotes, while the factory load will stop anything that lives in America.

My neighbor, Frank Dupries, loads brass shot gun shells with 3½ drams of powder and one ounce of No. 6 shot. He applies 60 pounds pressure to the powder and uses the common No. 2 primer. That load is entirely satisfactory, both behind the trap and after ducks.

Milton Prichard, Vancouver, Wash.

## SAVAGE IS THE BEST.

Anyone wishing a gun and not knowing what caliber to get, can decide by reading a few copies of RECREATION, as the gun and ammunition department gives good advice. The .303 Savage is the best all around gun made, and the 38-55 Winchester is a good caliber; but for hunting grizzlies and large game in the North, I prefer the 45-70-405 smokeless Government soft point. I have a 45-70 Remington, Model 74, that is a fine, hard shooting gun. It has good steel in it, as it was made before manufacturers knew how to make cheap or bad guns. It is built about like an old log wagon; can not be broken. Another man with a Savage might shoot 3 times to my once, but I prefer one well aimed shot to 6 wild ones.

I should like to see the Savage Arms Co. put out a 45-500 smokeless. I believe it would be a great gun for big game. The

30-30, soft nose, has been overdone. The bullets nearly always fly to pieces when striking bone. The .45 does not often leave the jacket, but if it should, there would be enough weight and force of the lead to go on and do effective work.

V. P. Cutler, Canon City, Colo.

#### SMALL SHOT.

I do not like Peters cartridges. Out of a box of 22 longs, 5 missed and 4 hung fire. One of the latter hung so long that I had removed the rifle from my shoulder and was opening the breach, when it went off. No more Peters' for me. Three young men of this place went out on the prairie last fall to hunt geese. One man, after firing the first cartridge from his Marlin rifle, attempted to throw the lever, but it stuck solid and he had to go back to town and have the action taken apart. In what fix would he have been, if he had shot a bear and wounded it? The Marlin rifle is simply an imitation of the Winchester, made as nearly like it as possible without infringing on Winchester patents, but the less said about the action the better. If Marlin would go into the single shot business entirely he would probably do better.

Al. Kennedy, Post Falls, Ida.

In answer to Pard Roll, the 25-35 is powerful enough for the game he mentions, if he can put his lead in the right place. I prefer the Savage .303 on account of the neater hang of that rifle. There is no difference in accuracy between the .303 Savage and the .30-30 Winchester. The Stevens .22 caliber is not more accurate than the Winchester model 1890 repeater.

To E. W. Summers: I have used 4 Stevens rifles and never noticed any serious looseness in the working of the lever. One loosened a little, after a year's use, but was easily tightened. The 32-40 is not too large for grouse if you can behead them, although it would mangle the bird if hit otherwise.

To C. W. Linberger: The range of the 25-20 Winchester is about 200 yards, the penetration  $7\frac{1}{4}$  one inch pine boards at 20 feet.

Harry Braconier, Campello, Mass.

In May RECREATION B. L. Dingley inquires as to the safety of using nitro powder in old guns. I have a Scott hammer, 12-gauge gun, made in 1880 and used continually ever since. I have used nitro powder in it ever since that powder came into general use, with heavy charges for ducks, etc., without any trouble resulting. It is the best shooting gun I ever saw, and originally cost \$125. The right barrel is modified choke; the left, full choke. Much

depends on the quality of the barrels, of course, but from my experience I should conclude that Mr. Dingley would be perfectly safe in shooting nitro powder in the gun he describes, if reasonable charges were used. If heavy loads of powder were used, I should recommend that the charge of shot should not exceed one ounce.

C. M. Coleman, Telluride, Colo.

Why a true sportsman wishes to use a pump gun to shoot ducks, quails, etc., is past my reasoning. Two shots are more than enough to fire at a covey of quails. A single shot and one bird scored is more sportsmanlike than 2 shots and one or 2 crippled birds. Some get the idea that to take a dog or 2, a pump gun, go to the field, flush a covey, bang away as long as there is a bird in sight, and pick up whatever falls, counting 2 or 3 wounded, is sport. Why not use a double gun and be satisfied with 2 shots and less cripples? Not 3 times in 5 do I get 2 shots at a covey. I would rather score the first and run the risk of another single than to cripple a bird and lose it. The quails wintered well here and are numerous; rabbits also. With a dry nesting season, there should be good sport next fall.

C. B. H., Markleville, Ind.

In reply to Mr. Beckwith's question about Lyman sights, would say I have a set of them on a 38-55 rifle. They are good for target or long-distance shooting; but give me an open sight for deer and similar game.

Will readers tell their experience with the new 35 caliber Winchester box magazine? I believe it is a good gun for big game.

L. A. Dougherty, Three Rivers, Mich.

There has been much talk in RECREATION about the all around rifle. Would not the 32-40 with nickel steel barrel to handle the new 32-40 high pressure smokeless load fill the bill? It gives higher velocity and greater penetration than the 30-30 and .303. Would it not give proportionate results with black and low pressure powders, and thus be available for all kinds of shooting?

M. E. Longstreth, Towanda, Kan.

I am thinking of buying a rifle for woodchuck and squirrel shooting, but am undecided what caliber to choose. Would the 25-20, '92 model, Winchester carbine be suitable? What is the heaviest charge that can be used with that gun? What would make an accurate light load for gallery practice?

Henry Wiggen, Jr., Middletown, N. Y.



## NATURAL HISTORY.

When a bird or a wild animal is killed, that is the end of it. If photographed, it may still live and its educational and scientific value is multiplied indefinitely.

### TRAPPING ON A MICHIGAN LAKE.

J. A. NEWTON.

Nagley's lake, in Michigan, is a profitable trapping ground for the taking of animals amphibious in habits. While the water is open, it affords satisfactory returns for the trapper's efforts for about one week each autumn.

In the fall of '98, in company with my old partner, Al, I trapped there, it being our 4th season on the lake and its outlet and feeders. We had been there, too, in summer to test the fishing, and found that on certain days we could take more grass pike, bass, etc., than we wanted. Then the bittern was booming, the frog orchestra was in tune and the night hawk descended with its spinning swoop.

Now nature's summer garb was laid aside, and a strenuous little army of workers had already prepared their habitations for winter. Dozens of mud-bedaubed grass huts were to be seen extending up the shore of an arm of the lake as far as the eye could reach. This panorama of homes was a pleasing outlook for profit, and Al chuckled at the thought of pelts galore. He is thoroughly practical in his nature, believing that all creatures are made to be sacrificed either as a benefit or a nuisance. I have tried to reason with him that our taking of life should be tinctured with pity, if not remorse; but Al laughs and says I am too conscientious to be a trapper.

We launched our boats, Al taking the main shore and I the island, which is some 300 acres in extent, a part being heavily timbered. Signs of muskrat were everywhere numerous, and there were also signs of coons and minks in the muddy margin. No traps can be set for the latter until a catch of rats has been made, because flesh of some kind must be used for bait, and for this purpose nothing equals muskrat meat.

Three hours sufficed to set out my traps, and as Al was hidden among the flags and tall reeds of a bay, I judged he was still occupied in placing his share. Turning about, I made for the landing, feeling confident of a large catch on the morrow. My traps were set at the foot of houses on the most sloping sides, on feed beds where fresh cuttings were seen, and in runways where they meet the water. Then there were bogs and snags containing signs where the hatchet was used to make a bed for the trap. In all cases the trap was set barely submerged and staked in deep

water, so the rat would drown when caught, lest it wring a foot off and escape.

On the island, game was plentiful in the wooded portion, and being but little hunted, was exceedingly tame. Evening was approaching, and fox squirrels were barking on every hand. Now and again I heard the sound of their claws ripping the bark as they moved in haste. Grouse were also numerous, and so tame that after flying a few yards they would alight and crane their necks askance at my intrusion.

"How many traps did you set?" I asked Al on his return.

"Thirty-nine," he said, "and I didn't get over half of the ground."

I had set 33, making a total of 6 dozen. While preparing our supper we fell into speculation as to our probable catch for the night. No sport causes a keener sense of anticipation than the thought of what one's traps may contain. It was therefore with the greatest alacrity that we plied our paddle the following morning in running the traps.

The first trap was off a bog, and I pulled from the slimy ooze a large drowned rat. The next was at a house. The trap had sprung, but failed to catch. I reset it and came to a dense patch of floating flags, where, in a space of a dozen feet, I had set 5 traps. Around 3 the flags were all chewed down, proving that many rats had been prisoners and had bitten everything in reach in their efforts to escape. Taking hold of the chains I brought up 2 well furred rats; the other trap had become entangled and contained only a foot. The poor animal was now in some retreat nursing a bleeding stump.

It is a curious fact that a dismembered foot rarely causes the death of the rat. It soon heals, and but little inflammation occurs, probably on account of the cooling influence of the water.

In fall many kits or rats of a late litter are caught, which have but little value, and the trapper learns to expect a percentage of them in his catch.

Suddenly the sharp report of Al's revolver came across the lake to me, which presaged larger game than rats, for I knew he never wasted a 38 cartridge. Coming to a sand bar where no traps were set curiosity prompted me to run across and find out the meaning of that shot. He had run no more of his traps than I, but had taken 16 rats to my 13. He also had a large coon. Blood trickling from the coon's head ex-

plained the cause of the report I had heard. To my question, Al replied,

"He blundered into a trap set on a house, chewed the stake off, started off with the trap, and got fast in a brush heap. I heard him smashing around, and when I got my eye on him I cut loose from the boat and laid him out the first shot, though he was 3 rods away."

The coon was evidently an old resident. His teeth were well worn, and one of his tough feet was minus 2 toes, which had long ago been taken off by some trap and were now healed perfectly.

We skinned enough rats to get bait for coons and minks. For these, traps are set in the mud or water's edge and a portion of muskrat is posted on a prong over the trap, which, when staked, is ready for any hungry or inquisitive animal that may inspect the lure.

Forty-one rats, one coon and a mink were the sum of the roundup. I had guessed we would catch 50, while Al, more conservative, had placed the number at 35. A week spent on Nagley and its outlet afforded 201 rats, 7 minks, 5 coons and 4 skunks. The last named we caught in deserted fox and badger dens in the hillside, by covering the trap with dry sand and placing a portion of muskrat in the hole below the trap.

Having trapped Nagley's, we packed up and moved to Crooked lake, which is much smaller, but affords good trapping while it lasts.

On the way we stopped to visit the owner of a skunk pen. It was the second season of his venture and he was by no means enthusiastic. He said that not only did the adults devour the young, but that animals in confinement do not acquire a good growth of fur.

"I sold 60 skins last December," he said, "which were so thinly furred, as compared with those taken in their native haunts, that I was obliged to take 30 per cent. less. If the animals do not fur better next season, I shall give up the business." I have since learned that, meeting with the same disappointments, the experimenter has sold out and given up his task.

#### FOREIGN BIRDS FOR THE UNITED STATES.

A great German naturalist says it is a universal law of bird life that all migratory birds go from their equatorial limit toward the poles to breed, never in the other direction; that in migrating they never cross a large body of water except where their remote ancestors in former geological ages passed over dry land. He gives as an instance that the nightingale in crossing from France to England does not cross at the

narrowest part of the English channel, but at the point where there was formerly connection between the 2 countries.

Captain Nathorn, in searching for traces of André, the balloon explorer, on the Liverpool coast of East Greenland, found the European robin redbreast, *Esithacus rabecula*, "breeding in incredible numbers" on the cliffs of East Greenland. A glance at the map will show that this brave little bird must pass from Norway to Greenland, following his ancient path, when he could have crossed continuous land, except the narrow passage of Baffin's bay, if he followed the coast Southward to America.

In my opinion, we have here the key to the failure of the few attempts to acclimate migratory birds in America. The birds followed the Atlantic coast Southward, were caught in a trap on the South end of Florida, and lost at sea.

The remedy is an international acclimatization society, with headquarters at Tampico, Mexico, a deep water port on the verge of the tropics, close to a high and temperate tableland, and, above all, with a continuous land connection North and South. The vast majority of European and Asiatic migratory birds breed on the Fundas, vast frozen marshes of Northern Europe and Asia. These marshes are covered with berries in the short summer, and they are preserved under the early snow until the next spring, when the birds live on them and raise their young.

The birds successfully imported to Portland, Oregon, have been seen in Central America in winter, but return in spring. Here again there is unbroken land North and South. The character of every bird we would import has been known for ages; the blunder of the European sparrow need not be repeated. I saw lately in a New Zealand paper a resumé of 25 or more years' experience in bird acclimatization. It regretted the importing of the European sparrow, greenfinch and blackbird; all the rest, and those were many, were considered desirable acquisitions.

Of the enormous number of European and other song birds imported every year to New York, RECREATION could easily give us interesting statistics. I got what little I could find out on this subject in English papers. The starling, robin redbreast and Pekin nightingale are imported to New York.

Following is a list of birds which we might have had 50 years ago if we had 1-10 of the enterprise of every little colony in Australia and New Zealand: Nightingale, *Dalias lacenca*; blackcap, *Sylvia atricapilla*; whitethroat, *Sylvia cinerea*; thrush, *Furdus musicus*; \*skylark, *Alanda arvensis*; \*woodlark, *Alanda arborea*; \*grey linnet,

*Linota cannabina*; \*lisken, *Carduelis spinus*; \*goldfinch, *Carduelis elegans*.

Those marked with asterisk have been already successfully acclimatized in Oregon, with many others, both useful and beautiful, which we ought to have. The 3 first, nightingale, blackcap and whitethroat, have for ages been considered unrivaled in song. Who will be the Carnegie to give America these birds, worth all the opera singers that ever crossed the Atlantic?

Edward K. Carr, Kerrville, Tex.

#### WILD HOGS.

About 40 years ago someone started a hog ranch on an island off our Western coast. The venture failed, and the hogs were left to run wild among the rocky canyons and sand dunes, where they exist by grubbing up cacti roots and eating kelp along the shores.

The foreman of the sheep ranch now occupying the island has waged a war of extermination on these wild hogs, and has driven them back to the wildest part of the island. Probably 15 generations of freedom have made these animals wholly unlike their domesticated ancestors. Their activity and strength are marvelous, and they are exceedingly tenacious of life. Brown in color, their razorback look is increased by a mane of long bristles extending in a narrow strip from the ears to the rump. The old boars have long, sharp tusks and are probably as formidable antagonists as bears.

Recently while riding across the island I had my first encounter with them. Many canyons with steep, rocky sides run across the island. On coming to the mouth of one of these I saw a hog some distance above me. Seeing me, she ran up a path toward the ridge, while I threw balls from my 45 revolver at her. A deer couldn't run faster over the same ground. At the 6th shot she came down, with 2 holes in her, the last through the heart. The distance was about 100 yards.

As I reloaded my revolver I saw a large hog running up the canyon 200 yards away and spurred my horse after him. After a mile or 2 he turned up a rock canyon with straight walls, and with only a narrow path about 100 feet from the bottom. The hog stopped in a crevasse and suddenly jumped out not over 60 feet away. I emptied my revolver at him, the horse meanwhile on the gallop, and could see I hit in at least 2 places. Here the cactus was thick and while reloading I lost sight of the boar. Turning back I was amazed to see where I had been riding, as I could drop an empty cartridge 100 feet straight down at places.

On turning a sharp curve I met another

boar. He promptly charged, but 2 bullets changed his mind and he turned up a little path that led to the open land above. Just as he reached the edge a ball caught him in the side, coming out of his back. He fell and rolled to the bottom, probably 250 feet. When I found him it took 3 more half ounces of lead to put him out. He was hit 7 times out of 13 shots, and 4 balls had gone through his lungs.

Such tenacity of life is equalled by few animals. The foreman recently hit a charging boar 10 times with a 44 Winchester. A friend of his, with a Savage, using soft nose bullets, found it necessary to "keep a-shooting" in order to stop them. Of course, brain, heart or backbone shots are fatal, but they will stand for appalling wounds that do not touch those spots, and still carry themselves handily; one broken leg is almost no handicap at all.

H. J. Angle, Santa Rosa Is., Cal.

#### NATURAL HISTORY NOTES.

Last fall I shot a white deer in Maine. I have received so many inquiries in regard to it that I would like to know if any pure white deer was ever shot before. I have seen a number of so-called white deer, but they were all more or less spotted. The one I shot was a 179-pound buck, 6 points. The only color was a narrow strip on top of forehead, extending to the antlers. I have had the skin mounted and shall soon have some photos of him. A number of guides have seen him and told me they never saw one as white, so I am naturally interested to find out if this is a rare specimen.

G. E. Palmer, Revere, Mass.

#### ANSWER.

White deer are so common they are of little interest except locally. Museums care little for them. Mottled or piebald specimens are more common than those entirely white, but there are in the United States several mounted specimens that are absolutely white. Albinism is much more common among white tailed deer than any other deer species known, except the fallow deer of Europe. Of that, a white breed exists in a few private parks in England.—EDITOR.

An old hunter here, locally accepted as an authority on all questions pertaining to the habits of game, says that, in districts where their nests are liable to molestation by weasels and other vermin, geese occasionally nest in trees and carry their young to the water in their bills. Do you think he is right?

A. Delanny, S. Omaha, Neb.

#### ANSWER.

In reply to above, Mr. C. W. Beebe, Cu-

rator of Birds of the New York Zoological Park, furnishes the following statement:

Herring gulls in Maine nest in trees, and sometimes on the ground. Ospreys on Gardiner's island sometimes nest on the ground, but usually in trees. It is not impossible that a goose might nest in a tree, but there is no recorded instance that I know of. They build compact nests.

Can prairie chickens be propagated in captivity? If so, would they thrive in South Carolina or Florida?

J. R. Boyd, Greensboro, N. C.

ANSWER.

The pinnated grouse never has been introduced into any country not originally inhabited by it. I think it could not survive in either South Carolina or Florida, because its natural food would be lacking, its enemies too numerous, and the dry, open, grain-covered uplands too limited. The rainfall in summer would also probably prove too great. There is reason to believe that this bird can be propagated in captivity; but just how, remains to be demonstrated.—EDITOR.

I have in my yard a number of red squirrels so tame that they will eat from my hands and sit on my shoulders. Recently I loosed a pair of fox squirrels, equally tame. The reds annoy them, and I fear I must choose between my old pets and the new. Of the 2, I prefer the fox squirrels. What would you advise me to do?

W. H., Middletown Springs, Vt.

ANSWER.

It is to be expected that the red squirrels will eventually drive away the grays. The former are quarrelsome and pugnacious; the latter, timid. It will probably be necessary to choose between the 2 species. Most people kill the reds to protect the grays.—EDITOR.

Please tell me the name of a little snake I saw swimming in a pond. It was 5 or 6 inches long and no thicker than a hair. Some call them hair snakes.

L. E. Lane, Brockton, Mass.

ANSWER.

The creature observed was a hair worm, also called hair eel, which is so long and hairlike it has created in the minds of a few persons the belief that it really is a horsehair transformed into a worm. Some persons honestly believe they have seen horsehairs turn into worms, but this only proves that the human eye is easily deceived. The scientific name of this creature is *Gordius aquaticus*.—EDITOR.

Please tell me whether sharks lay eggs or not.

Anthony Ranker, Jersey City, N. J.

ANSWER.

Of the 150 species of sharks, about  $\frac{1}{2}$  lay eggs, and  $\frac{1}{2}$  produce their young alive. The eggs of those that are oviparous are rectangular in shape, flattened, and have in each corner a thread-like tendril by which the egg is attached to some fixed object.—EDITOR.

Will some reader of RECREATION please tell me how to tan snake skins?

L. H., care RECREATION.

It is early to think of winter sport, but not too early to provide an outfit. An important part of this is a pair of skates. No better ones are made than Barney & Berry's, and you can earn a handsome pair of them by sending me only 5 yearly subscriptions to RECREATION. These fall evenings will be a good time to get the subscriptions, and the skates will make you the envy of all your fellow skaters.

I am much pleased with RECREATION. I regard it as the best publication of the kind in the market. The manner in which it is got up is excelled by none. I have a copy of "Big Game of North America," and have read with much pleasure your contribution to it.

L. A. Moore, Zanesville, Ohio.

I have been reading RECREATION about a year, and find I could not do without it. I like your way of giving the hogs h—. Give it to them hard! They deserve all they get and more.

A. Lucius, Jr., Solon Springs, Wis.

RECREATION is the best magazine of its kind published. I have read many different sportsmen's magazines, but none, although higher in price, equals RECREATION.

Paul A. Greenamayer, Columbiana, O.

I have just finished reading your book, "Hunting in the Great West." It and RECREATION are both all right. Down with the game hogs, and long live RECREATION.

Ed. C. Mahaffey, Mount Vernon, O.

It is needless to say I am glad to get RECREATION, among the first of the magazines to arrive; that is its proper place.

R. H. Vardon, Toronto, Canada.

In this little town of 1,500 there are now about 200 persons who subscribe for RECREATION.

F. O'Brien, Redfield, S. D.

# THE LEAGUE OF AMERICAN SPORTSMEN.

## GENERAL OFFICERS

*President*, G. O. Shields, 23 W. 24th St., New York.

*1st Vice-President*, E. T. Seton, 80 West 40th St., New York.

*2d Vice-President*, W. T. Hornaday, 2969 Decatur Ave., Bedford Park, N. Y.

*3d Vice-President*, Dr. T. S. Palmer, Dept. of Agriculture, Washington, D. C.

*4th Vice-President*, A. A. Anderson, 80 West 40th St., New York.

*5th Vice-President*, Hon. W. A. Richards, General Land Office, Washington, D. C.

*Secretary*, A. F. Rice, 155 Pennington Ave., Passaic, N. J.

*Treasurer*, Austin Corbin, of the Corbin Banking Co., 192 Broadway, New York.

## ALASKA DIVISION.

Dr. E. M. Rininger, Chief Warden, Nome.

## ARIZONA DIVISION.

M. J. Foley, Chief Warden, Jerome.

## ARKANSAS DIVISION

W. R. Blockson, Chief Warden, Eureka Springs.

## CALIFORNIA DIVISION.

Dr. David Starr Jordan, Chief Warden, Leland Stanford University.

## COLORADO DIVISION.

A. Whitehead, Chief Warden, 303 Tabor Building, Denver.

## CONNECTICUT DIVISION.

Hon. F. P. Sherwood, Chief Warden, Southport; Dr. H. L. Ross, Vice-Warden, Canaan; H. C. Went, Sec.-Treas., Bridgeport.

## DISTRICT OF COLUMBIA DIVISION.

C. H. Townsend, Chief Warden, U. S. Fish Commission.

## FLORIDA DIVISION.

W. W. K. Decker, Chief Warden, Tarpon Springs

## GEORGIA DIVISION.

J. J. Doughty, Chief Warden, Augusta.

## IDAHO DIVISION.

L. A. Kerr, Chief Warden, Kendrick

## ILLINOIS DIVISION.

M. D. Ewell, M.D., Chief Warden, 59 Clark St., Chicago; F. M. Taber, Vice Warden, 144 Kinzie St., Chicago; G. C. Davis, Sec.-Treas., 123 S. Central Ave., Austin.

## INDIANA DIVISION.

Frank L. Littleton, Chief Warden, 30 $\frac{1}{2}$  East Washington St., Indianapolis; J. J. Hildebrandt, Vice Warden, Logansport; T. J. Carter, Sec.-Treas., State House, Indianapolis.

## IOWA DIVISION.

Carl Quimby, Chief Warden, Des Moines; C. C. Proper, Sec.-Treas., Des Moines.

## KANSAS DIVISION.

O. B. Stocker, Chief Warden, Wichita; A. J. Applegate, Sec.-Treas., 113 E. 1st St., Wichita

## KENTUCKY DIVISION.

Geo. C. Long, Chief Warden, Hopkinsville.

R. L. Brashear, Sec.-Treas., Bowling Green.

## MAINE DIVISION.

Col. E. C. Farrington, Chief Warden, Augusta.

## MARYLAND DIVISION

J. E. Tylor, Chief Warden, Baltimore.

## MASSACHUSETTS DIVISION.

Heman S. Fay, Chief Warden, Hazleton Block, Marlboro; J. E. Tweedy, Vice-Warden, North Attleboro; A. C. Lamson, Sec.-Treas., 194 Main St., Marlboro.

## MICHIGAN DIVISION.

J. Elmer Pratt, Chief Warden, Grand Rapids; R. S.

Woodliffe, Vice-Warden, Jackson; A. B. Richmond, Sec.-Treas., Grand Rapids.

## MINNESOTA DIVISION.

Dietrich Lange, Chief Warden, 2294 Commonwealth Ave., St. Paul.

H. A. Morgan, Vice-Warden, Albert Lea; Prof. O. T. Denny, Sec.-Treas., St. Paul.

## MISSOURI DIVISION.

Bryan Snyder, Chief Warden, 726 Central Bldg., St. Louis.

## MONTANA DIVISION.

Professor M. J. Elrod, Chief Warden, Missoula; Sidney M. Logan, Vice-Warden, Kalispell; R. A. Wagner, Sec.-Treas., Bozeman.

## NEBRASKA DIVISION.

Fred. E. Mockett, Chief Warden, Lincoln; P. O'Mahony, Sec.-Treas., Lincoln.

## NEVADA DIVISION.

Dr. W. H. Cavell, Chief Warden, Carson.

Geo. W. Cowing, Sec.-Treas., Carson.

## NEW HAMPSHIRE DIVISION.

Dr. A. F. Barrett, Sentinel Bldg., Keene, Sidney Conant, Sec.-Treas., Keene.

## NEW JERSEY DIVISION.

Percy Johnson, Chief Warden, Bloomfield; Dr. W. S. Colfax, Vice-Warden, Pompton Lakes; I. V. Dorland, Sec.-Treas., Arlington.

## NEW MEXICO DIVISION.

P. B. Otero, Chief Warden, Santa Fe.

## NEW YORK DIVISION.

John R. Fanning, Chief Warden, Powers' Bldg., Rochester; Col. R. E. Moss, Vice-Warden, Wallack's Theatre, New York City; Dr. C. C. Curtis, Sec.-Treas., Columbia College, New York City.

## NORTH DAKOTA DIVISION.

Dr. W. D. Jones, Chief Warden, Devil's Lake.

## OHIO DIVISION.

W. E. Gleason, Chief Warden, Mitchell Bldg., Cincinnati; A. C. Thatcher, Vice-Warden, Urbana.

## OKLAHOMA DIVISION.

W. M. Grant, Chief Warden, Oklahoma City.

## ONTARIO DIVISION.

C. A. Hammond, Chief Warden, Box 701, St. Thomas; D. L. Mells, Sec.-Treas., St. Thomas.

## OREGON DIVISION.

Robert F. Kelly, Chief Warden, Box 188, The Dalles; C. B. Cushing, Sec.-Treas., The Dalles.

## PENNSYLVANIA DIVISION.

C. F. Emerson, Chief Warden, 189 N. Perry St., Titusville; Hon. C. B. Penrose, Vice-Warden, 1720 Spruce St., Philadelphia; E. Wager-Smith, Sec.-Treas., 1026 Ridge Ave., Philadelphia.

## RHODE ISLAND DIVISION.

Zenas W. Bliss, Chief Warden, 49 Westminster St., Providence.

## SOUTH CAROLINA DIVISION.

C. F. Dill, Chief Warden, Greenville.

## SOUTH DAKOTA DIVISION.

D. C. Booth, Chief Warden, Spearfish; John C. Barber, Sec.-Treas., Lead.

## TENNESSEE DIVISION.

Hon. G. C. Martin, Chief Warden, Clarksville; Hon. Austin Peay, Jr., Sec.-Treas., Clarksville.

## TEXAS DIVISION.

Prof. S. W. Stanfield, Chief Warden, San Marcos; W. E. Heald, Sec.-Treas., San Angelo.

## UTAH DIVISION.

Hon. John Sharp, Chief Warden, Salt Lake City.

## VERMONT DIVISION.

W. E. Mack, Chief Warden, Woodstock; S. C. White, Sec.-Treas., Woodstock.

## VIRGINIA DIVISION.

R. G. Bickford, Chief Warden, Newport News. C. O. Saville, Vice Warden, Richmond; M. D. Hart, Sec.-Treas., 1217 East Main St., Richmond.

## WASHINGTON DIVISION.

F. S. Merrill, Chief Warden, Spokane; F. A. Pontius, Sec.-Treas., Seattle; Munro Wyckoff, Vice-Warden, Pt Townsend.

WEST VIRGINIA DIVISION.  
 E. F. Smith, Chief Warden, Hinton,  
 WISCONSIN DIVISION.  
 Frank Kaufman, Chief Warden, Two Rivers; Dr.  
 A. Gropper, Sec.-Treas., Milwaukee.  
 WYOMING DIVISION.  
 H. E. Wadsworth, Chief Warden, Lander; Frank  
 Bond, Sec.-Treas., Cheyenne.  
*Applications for membership and orders for badges  
 should be addressed to Arthur F. Rice, Secretary, 23 W.  
 24th St., New York.*

County.	Name of Warden.	Address.
New York,	Conrad L. Meyer,	46 W. Broadway.
Livingston	M. De La Vergne,	Lakeville.
"	K. S. Chamberlain,	Mt. Morris.
"	Henry Skinner,	Springwater.
"	Dr. J. W. Cowan,	Geneseo.
Albany,	C. D. Johnson,	Newtonville.
"	Kenneth E. Bender,	Albany.
Broome,	John Sullivan,	Sanitaria Springs
"	R. R. Mathewson,	Binghamton.
Cayuga,	H. M. Haskell,	Weedsport.
Chemung,	Fred. Uhle,	Hendy Creek,
"	M. A. Baker,	Elmira.
Cortland,	James Edwards,	Cortland,
Erie,	E. P. Dorr,	103 D. S. Morgan Building, Buffalo.
"	Marvin H. Butler,	Morilla.
Essex,	W. H. Broughton,	Moriah.
Franklin,	Jas. Eccles,	St. Regis Falls.
Montgomery,	Charles W Scharf,	Canajoharie.
Oneida,	J. M. Scoville,	Clinton.
Orange,	Wilson Crans,	Middletown.
"	J. Hampton Kidd,	Newburgh.
"	Thomas Harris,	Port Jervis.
Richmond,	Lewis Morris,	Port Richmond.
St. Lawrence,	Dr. B. W. Severance,	Gouverneur
"	A. N. Clark,	Sevey.
Schenectady,	J. W. Furnside,	Schenectady.
Suffolk,	F. J. Fellows,	Central Islip, L. I.
"	P. F. Tabor,	Orient, L. I.
Tioga,	Geo. Wood,	Owego.
Washington,	C. L. Allen,	Sandy Hill.
"	A. S. Temple,	Whitehall.
"	J. E. Barber,	Dresden.
Westchester,	George Poth,	Pleasantville.
"	Chas. Seacor,	57 Pelham Road, New Rochelle.
"	M. W. Smith,	Croton Falls.
"	Ralph Gorham,	Mt. Kisco
Dutchess,	A. B. Miller,	Jackson's Corners.
Columbia,		
Onondaga,	James Lush,	Memphis.
Yates,	B. L. Wren,	Penn Yan.
"	Symour Poineer,	Branch Port.
Dutchess,	Chas. H. DeLong,	Pawling.
"	Jacob Tompkins,	Billings.
Queens,	Gerard Van Nostrand,	Flushing, L. I.
"	W. S. Mygrant,	46 Elton Street, Brooklyn.
"	P. A. Geepel,	473 Grand Ave., Astoria, L. I.
"	L. B. Drowne,	119 Somers Street, Brooklyn.
Ulster,	M. A. DeVal,	The Corners.
"	Wm. S. Mead,	Woodstock.
Jefferson,	C. J. Smith,	Watertown.
"	A. C. Cornwall,	Alexandria Bay,
"	Jos. Northrup,	"
Herkimer,	D. F. Sperry,	Old Forge.
Oswego,	J. E. Manning,	154 West Utica St.
Putnam,	H. L. Brady,	Mahopac Falls.
Schuyler,	G. C. Fordham,	Watkins.
Allegany,	G. A. Thomas,	Belvidere.
Schoharie,	O. E. Eigen,	Sharon Springs.
Warren,	Geo. McEchron,	Glen Falls.
Orleans,	J. H. Fearby,	E. Shelby.
Greene,	W. J. Soper,	Windham.
Hamilton,	David Aird, Jr.,	Lake Pleasant.

LOCAL WARDENS IN OHIO.

Stark,	A. Dangeleisen,	Massillon.
Franklin,	Brook L. Terry,	208 Woodward Av., Columbus.
Cuyahoga,	A. W. Hitch,	161 Osborn St., Cleveland.
Clark,	Fred C. Ross,	169 W. Main St., Springfield.
Erie,	David Sutton,	418 Jackson St., Sandusky.
Fulton,	L. C. Berry,	Swanton.

County.	Name of Warden.	Address.
Allen,	S. W. Knisely,	Lima.
Hamilton,	W. C. Rippey,	4465 Eastern Ave. Cincinnati.
Knox,	Grant Phillips,	Mt. Vernon.
Lorain,	T. J. Bates,	Elyria.
Ottawa,	Frank B. Shirley,	Lakeside.
Muskingum,	Frank D. Abell,	Zanesville.
Scioto,	J. F. Kelley,	Portsmouth.
LOCAL WARDENS IN CONNECTICUT.		
Fairfield,	George B. Bliss.	2 Park Row, Stam- ford, Ct.
"	Harvey C. Went,	11 Park St., Bridge- port, Ct.
Fairfield,	Samuel Waklee,	Box 373, Stratford.
Litchfield,	Dr. H. L. Ross,	P. O. Box 100, Ca- naan, Ct.
Middlesex,	Sandford Brainerd,	Ivoryton.
New Haven,	Wilbur E. Beach,	318 Chapel Street, New Haven Ct.
"	D. J. Ryan,	188 Elizabeth St., Derby.
LOCAL WARDENS IN MASSACHUSETTS.		
Norfolk,	Orlando McKenzie,	Norfolk.
"	J. J. Blick,	Wrentham.
"	S. W. Fuller,	East Milton.
Suffolk,	Capt. W. J. Stone,	4 Tremont Row, Boston.
Worcester,	B. H. Mosher,	Athol.
LOCAL WARDENS IN NEW JERSEY.		
Mercer.	Edw. Vanderbilt,	Dentzville, Trenton.
"	Roland Mitchell,	739 Centre St., Trenton.
"	F. C. Wright,	Trenton.
Morris,	Joseph Pellet,	Pompton Plains.
"	Chas. W. Blake,	Dover.
"	Francis E. Cook,	Butler.
"	Calone Orr,	Hibernia.
Somerset,	G. E. Morris,	Somerville.
Sussex,	Isaac D. Williams,	Branchville.
Union,	A. H. Miller,	Cranford.
"	C. M. Hawkins,	Roselle.
Warren,	{ Jacob Young,	Phillipsburg.
"	{ Reuben Warner,	
Monmouth	Dory-Hunt,	Wanaque.
Hudson,	A. W. Letts,	51 Newark St., Hoboken
LOCAL WARDENS IN PENNSYLVANIA.		
Jefferson,	John Noll,	Sykesville.
Perry,	Samuel Sundy,	Lebo.
Warren.	F. P. Sweet,	Goodwill Hill.
"	Nelson Holmes,	Cornplanter.
Juniata,	Clifford Singer,	Oakland Mills.
"	Ezra Phillips,	McAlesterville.
Venango,	G. D. Benedict,	Pleasantville.
Potter,	Ira Murphy,	Coudersport.
"	Wiley Barrows,	Austin.
"	Chas. Barrows,	Austin.
Crawford,	Jasper Tillotson,	Tillotson.
"	Geo. T. Meyers,	Titusville.
"	J. B. Lamb,	Buel.
Cambria,	W. H. Lambert,	720 Coleman Ave., Johnstown.
Butler,	F. J. Forquer,	Murrinsville.
Allegheny,	S. H. Allen,	Natrona.
Beaver,	N. H. Covert,	Beaver Falls.
"	W. R. Keefer,	"
McKean,	C. A. Duke,	Duke Center.
"	L. P. Fessenden,	Granere.
"	Wm. Holsinger,	Stickney.
Lackawanna,	Wm. Weir,	Moosic.
"	Wm. Major,	"
Carbon,	Asa D. Hontz,	East Mauch Chunk.
Cumberland,	J. C. Gill,	Mechanicsburg.
Wyoming,	Cyrus Walter,	Tunkhannock.
Tioga,	E. B. Beaumont, Jr.,	Lawrenceville.
"	G. H. Simmons,	Westfield.
Lycoming,	Jas. J. Brennan,	Oval.
"	B. D. Kurtz,	Cammal.
Delaware,	Walter Lussan,	Ardmore.
Montgomery,	L. C. Parsons,	Academy.
Bradford,	Geo. B. Loop,	Sayre.
Clarion,	Isaac Keener,	New Bethlehem.
Cameron,	Harry Hemphill,	Emporium.
Clinton,	M. C. Kepler,	Renovo.
"	Geo. L. Kepler,	Renovo.
Northumber- land.	{ G. W. Roher,	505 Anthracite St., Shamokin
Elk,	{ D. R. Lobaugh,	
Fayette,	Ely Cope,	Ridgway, Cadwallader.

LOCAL WARDENS IN MICHIGAN.

County.	Name of Warden.	Address.
Ottawa,	W. H. Dunham,	Spencer.
Kalamazoo,	C. E. Miller,	Augusta.
Berrien,	W. A. Palmer,	Buchanan.
Cass,	Thomas Dewey,	Dowagiac.
Hillsdale,	C. A. Stone,	Hillsdale.
Lake,	John Trieber,	Peacock,

LOCAL WARDENS IN VIRGINIA.

Mecklenburg,	J. H. Ogburn,	South Hil.
King William,	N. H. Montague,	Palls.
Smythe,	J. M. Hughes,	Chatham Hill.
King & Queen,	R. D. Bates,	Newtown.
Louisa,	J. P. Harris,	Applegrove.
Henrico,	W. J. Lynham,	412 W. Marshall.

East Rockingham, E. J. Carickhoff, Harrisonburg.

LOCAL WARDENS IN WYOMING.

Fremont,	Nelson Yarnall,	Dubois.
Uinta,	{ S. N. Leek,	} Jackson.
	{ F. L. Peterson,	
Carbon,	Kirk Dyer,	Medicine Bow.
Laramie,	Martin Breither,	Cheyenne.

LOCAL WARDENS IN TENNESSEE.

Sumner,	W. G. Harris,	Gallatin.
Stewart,	John H. Lory,	Bear Spring.
Robertson,	C. C. Bell,	Springfield.
Montgomery,	P. W. Humphrey,	Clarksville.
Madison,	H. T. Rushing,	Jackson.

LOCAL WARDENS IN NEBRASKA.

Hall,	E. C. Statler,	Grand Island
-------	----------------	--------------

LOCAL WARDENS IN NEW HAMPSHIRE.

Cheshire,	S. C. Ellis,	Keene.
Sullivan,	G. A. Blake,	Lempster.
"	J. W. Davidson,	Charlestown.

LOCAL WARDENS IN VERMONT.

Rutland,	Wm. J. Liddle,	Box 281, Fair Haven
Windsor,	F. A. Tarbell,	West Bridgewater.
Orleans,	E. G. Moulton,	Derby Line.
Essex,	H. S. Lund,	Granby.

LOCAL WARDENS IN ILLINOIS.

Rock Island,	D. M. Slottard,	12th Ave and 17th St., Moline.
Iroquois,	J. L. Peacock,	Sheldon.

LOCAL WARDENS IN OKLAHOMA.

Kiowa and Comanche Nation,	A. C. Cooper,	Ft. Sill.
----------------------------	---------------	-----------

LOCAL WARDENS IN IOWA.

Clinton,	D. L. Pascol,	Grand Mound.
Pottawattamie,	Dr. C. Engel,	Crescent.

LOCAL WARDENS IN WASHINGTON.

Okanogan,	James West,	Methow.
Stevens Co.,	Jacob Martin,	Newport.

LOCAL WARDENS IN UTAH.

Washington,	S. C. Goddard,	New Harmony.
"	J. A. Thornton,	Pinto.

LOCAL WARDENS IN KANSAS.

Ness,	Frank Lake,	Ransom.
-------	-------------	---------

LOCAL CHAPTERS.

Albert Lea, Minn.,	H. A. Morgan,	Rear Warden.
Angelica, N. Y.,	C. A. Lathrop,	"
Augusta, Mont.,	H. Sherman,	"
Austin, Minn.,	G. F. Baird,	"
Austin, Pa.,	W. S. Warner,	"
Boston, Mass.,	Capt. W. I. Stone,	"
Buffalo, N. Y.,	H. C. Gardiner,	"
Cammal, Pa.,	B. A. Ovenshire,	"
Champaign Co., O.	Hy. F. MacCracken	"
	Urbana,	"
Charlestown, N. H.,	W. M. Buswell,	"
Cheyenne, Wyo.,	J. Hennessy,	"
Choteau, Mont.,	G. A. Gorham,	"
Cincinnati, Ohio,	B. W. Morris,	"
Coudersport, Pa.,	I. L. Murphy,	"
Cresco, Iowa,	J. L. Platt,	"
Davis, W. Va.,	J. Heltzen,	"
Dowagiac, Mich.,	W. F. Hoyt,	"
East Mauch Chunk, Pa.,	E. F. Fry,	"
Evansville, Ind.,	F. M. Gilbert,	"
Fontanet, Ind.,	W. H. Perry,	"
Ft. Wayne, Ind.,	W. L. Waltemarth	"
Great Falls, Mont.,	J. M. Gaunt,	"
Heron Lake, Minn.,	K. C. Buckeye,	"
Holidaysb'g, Pa.,	T. J. Hemphill	"
Hopkinsville, Ky.,	Hunter Wood,	"
Indianapolis, Ind.,	Joseph E. Bell,	"
Jerome, Ariz.,	Dr. L. A. Hawkins,	"
Johnsonburg, Pa.,	W. J. Stebbins,	"

Kalispell, Mont.,	John Eakright,	Rear Warden.
Keene, N. H.,	F. P. Beedle,	"
Kingfisher, Okla.,	A. C. Ambrose,	"
Lake Co., Ind.,	Dr. R. C. Mackey,	"
Lawton, O. T.,	Marion Miller,	"
Lincoln, Neb.,	A. J. Sawyer,	"
Logansport, Ind.,	E. B. McConnell,	"
Ludington, Mich.,	G. R. Cartier,	"
McElhattan, Pa.,	A. B. Winchester,	"
Mechanicsburg, Pa.,	Dr. J. H. Swartz,	"
Minturn, Colo.,	A. B. Walter,	"
Morgantown, W. Va.,	B. S. White,	"
New Albany, Ind.,	Dr. J. F. Weathers,	"
New Bethlehem, Pa.,	Isaac Keener,	"
Oklahoma City O.T.,	N. F. Gates,	"
Penn Yan, N. Y.,	Dr. H. R. Phillips,	"
Phillips, Wis.,	F. K. Randall,	"
Princeton, Ind.,	H. A. Yeager,	"
Reynoldsville, Pa.,	C. F. Hoffman,	"
Ridgway, Pa.,	T. J. Maxwell,	"
Rochester, N. H.,	Gustave Andreas,	"
" N. Y.,	C. H. McChesney	"
St. Paul, Minn.,	O. T. Denry,	"
St. Thomas, Ont.,	L. J. Hall,	"
Schenectady, N. Y.,	J. W. Furnside,	"
Seattle, Wash.,	M. Kelly,	"
Syracuse, N. Y.,	C. C. Truesdell,	"
Terre Haute, Ind.,	C. F. Thiede,	"
The Dalles, Ore.,	C. B. Cushing,	"
Walden, N. Y.,	J. W. Reid,	"
Wichita, Kas.,	Gerald Volk,	"
Winona, Minn.,	C. M. Morse,	"

DISCOUNTS TO LEAGUE MEMBERS.

The following firms have agreed to give members of the L. A. S. a discount of 2 per cent. to 10 per cent. on all goods bought of them. In ordering please give L. A. S. number:

Syracuse Arms Co.,	Syracuse, N. Y.	Guns.
Davenport Fire Arms Co.,	Norwich, Conn.	Shot guns, rifles.
Gundlach Optical Co.,	Rochester, N. Y.	Photographic goods.
Blair Camera Co.,	Rochester, N. Y.	Photographic goods.
James Acheson,	Talbot St., St. Thomas, Ontario,	Sporting goods.

LIFE MEMBERS OF THE LEAGUE.

W. D. Ellis,	136 W. 72d street,	New York City.
A. F. Rice,	155 Pennington avenue,	Passaic, N. J.
Dr. W. A. Valentine,	5 W. 35th street,	New York City.
A. A. Anderson,	6 E. 38th street,	New York City.
A. V. Fraser,	478 Greenwich street,	New York City.
E. S. Towne,	care National Blank Book Co.,	Holyoke, Mass.
F. G. Miller,	108 Clinton street,	Defiance, Ohio.
Gen. J. F. Pierson,	20 W. 52d street,	New York City.
E. T. Seton,	80 W. 40th street,	New York City.
J. H. Seymour,	35 Wall street,	New York City.
A. G. Nesbitt,	Maple street,	Kingston, Pa.
D. C. Beard,	204 Amity street,	Flushing, L. I.
C. H. Ferry,	1720 Old Colony Bldg.,	Chicago, Ill.
Hon. Levi P. Morton,	681 5th avenue,	New York City.
H. Williams,	P. O. Box 156,	Butte, Mont
D. B. Fearing,	Newport,	R. I.
E. H. Dickinson,	Moosehead Lake Me.	
Lorenzo Blackstone,	Norwich, Conn.	
A. L. Prescott,	90 W. Broadway,	New York City.
G. S. Edgell,	192 Broadway,	New York City.
W. B. Mershon,	Saginaw, Mich.	
Hon. H. W. Carey,	East Lake, Mich.	
George Carnegie,	Fernandina, Fla.	
Andrew Carnegie,	2nd, Fernandina, Fla.	
Morris Carnegie,	Fernandina, Fla.	
W. L. Underwood,	52 Fulton street,	Boston, Mass.
C. E. Butler,	Jerome, Ariz.	
Mansfield Ferry,	183 Lincoln Park,	Boulevard, Chicago, Ill.
Austin Corbin,	192 Broadway,	New York City.
J. Stanford Brown,	480 Fifth Ave.,	New York City.
W. H. Smith,	Bryn Mawr,	Pa.
E. B. Smith,	Bourse Bldg.,	Philadelphia, Pa.
A. J. McClure,	158 State street,	Albany, N. Y.
J. Walter Thompson,	Times Bldg.,	New York City.
Clinton Gilbert,	2 Wall St.,	New York City.
E. J. Hudson,	33 East 35th St.,	Bayonne, N. J.
Col. J. C. O'Connor,	24 East 33d st.,	New York City.

## FORESTRY.

EDITED BY DR. B. E. FERNOW.

It takes 30 years to grow a tree and 30 minutes to cut it down and destroy it.

### WISCONSIN FORESTRY.

Another State has fallen in line in formulating a definite rational forest policy for itself. May 22 of this year the Governor of Wisconsin approved an act to establish a system of State forests and to promote improved methods of forestry.

The first attempt to secure something of the sort with any tangible result was made 6 years ago, when a commission of inquiry was enacted to draw up a plan to protect and utilize the forest resources of the State of Wisconsin.

As a result of this action, through co-operation with the Federal Forestry Division and the State Geological Survey, a comprehensive forest survey of the forested counties of the State was made and the results published as Bulletin No. 16 of the Forestry Division; also by the State Geological Survey. Various bills were proposed by the commission on the basis of this survey, but only this year did the matter take final shape. The act establishes a department of State forestry, under an unpaid board of 5 State forest commissioners, with the Attorney General, the Secretary of State and the State Treasurer as members *ex-officio*, the other 2 appointed by the Governor. These are to appoint a superintendent of forests, with a salary of \$2,500. This is about half what a really competent, first class man should command, and the appropriation for carrying out the provisions of the act is also a pittance, namely \$3,000. The superintendent shall be forest warden of the State, and as such responsible for the enforcement of the forest fire laws and for the protection of State lands against trespass. In this capacity he is clothed with sheriff's power, as are the fire wardens and other officers under him. He is to appoint 5 wardens, one or more in each town of the forested counties, and at request of supervisors in any county not specifically mentioned. These fire wardens are clothed with power to summon any citizen to assist in putting out fires. The county is to pay the expenses of such service up to a certain amount, namely, not to exceed \$100 for each 36 sections in any one year in any one town.

This provision may occasionally become impractical, and might prevent the extinguishment of fires, unless an emergency clause is added, which, under certain rules, permits an excess over this expenditure, which excess might be paid by the State.

This forest fire legislation had already been enacted in 1898 and 1899, and is only amplified and the execution placed under the new superintendent.

The most important feature of the act, however, is the establishment of a State forest reserve, which is to consist of all the lands still in the hands of the State, excepting swamp lands, lands suitable for agriculture, wood lots convenient to farm homes and isolated tracts not exceeding 80 acres. The reserve at present can not be large, for in 1898 the State owned less than 300,000 acres in the counties concerned; but further acquisition of lands is foreshadowed by grants of lands from private owners or otherwise.

This reserve the superintendent is to investigate with a view of placing it under forestry management and ruling out whatever is not desirable to hold in reserve. For the present he is to cut only the dead and down timber "with a view to the best possible financial return to the State."

It is to be wondered where in Wisconsin it may be practicable to cut dead and down timber at a profit. This cautious provision certainly does not recognize that forestry is much advanced beyond the stage of mere let alone or cleaning up. This half hearted recognition of what forestry means is rather disappointing in a State where, not the sporting interest, as in New York, dictates the forest policy, but the lumberman, with good sound business sense, and presumably with a realization of the fact that only reproduction, not non-utilization, is the hope of the future. He ought to be the advocate of sound forestry principles.

To be sure, "the superintendent of State forests shall, as soon as practicable, after this law shall have gone into effect, establish one or more forest experiment stations for the purpose of conducting researches into the best methods of forest management under the conditions prevailing in the various portions of Wisconsin"; and this is to be done in co-operation, whenever expedient, with the State University, the State Geological and Natural History Survey, the various scientific bureaus of the United States and other institutions of like character.

What can such experiments in forest management consist of? If forestry means anything it means providing a wood crop for the future. It certainly does not mean keeping the nature-grown forest intact, for



there is no virtue in leaving a crop unused. The sole aim of forestry is to replace the used crop. The only difference between forester and lumberman is in that one condition, that the forester is obliged to replace, to reproduce the forest.

In a forested country there are only 2 ways of reproducing a forest, namely, to remove the existing one and plant or sow the new one as the farmer does, or to let the old trees first sow the ground and then remove them to give light, air and water to the young crop. The first method may be applied only on open ground and requires a direct money outlay, which the law does not, at present at least, provide. The other method requires the cutting not only of dead but of live trees, which the law does not permit. In forestry all experiments require a long time on account of the slow growth of trees.

This is, of course, only a beginning, and for the first year the superintendent will have his hands full with organizing and studying his surroundings and possibilities, for which the provisions are perhaps sufficient. When he has studied the problems and made his recommendations to an intelligent and interested commission and Legislature, the needed changes in the law or the better appropriations can probably be brought about.

The facts to be emphasized are that forestry is, in its last analysis, nothing more nor less than the reproduction of wood crops—silviculture; that it does not prevent but necessitates the harvesting of the old crop; that the methods of silviculture are well known and not any more in the experimental stage, where professional knowledge exists. At least there are only few experiments that could be carried on in the manner which the law permits.

#### FORESTRY IN HAWAII.

The Legislature of the Territory of Hawaii has passed an act providing for a Board of Commissioners of Agriculture and Forestry, in which provision is made for a forest policy for the islands. This act provides for a superintendent of the Forest Department, who will have charge of all matters relating to forestry, and will be assisted by a corps of foresters and rangers. The matters particularly specified by the act as coming under the jurisdiction of the Forest Department include the custody and regulation of all lands to be set aside under the provisions of the act, and to protect the forests for the purpose of conserving and regulating the water supply. Ways and means are to be devised for making the forests self supporting, and measures are to be taken for the exclusion

of trespassers, stock, and fires from the public forest domain.

The Governor is authorized, by and with the consent of the Board of Commissioners of Agriculture and Forestry, to set aside lands for forest reservations and to accept the care and control of private lands for forest purposes.

The Territorial Senate has passed a bill which appropriates about \$23,500 a year for 2 years for the Department of Forestry, and provides for the salary of a chief forester at \$3,000. He will have full and direct control of the forest work, being independent of the experiment station and answerable only to the Board of Commissioners, whose members are appointed by the Governor, by and with the advice and consent of the territorial Senate.

Mr. William L. Hall, Chief of the Division of Forest Extension of the Federal Forestry Bureau, will start for Honolulu in August to assist in organizing the forest work.—Forestry and Irrigation.

#### OREGON AND CALIFORNIA.

Fifty-four townships in Southwestern Oregon and a tract of similar area on the California side of the State line have been withdrawn from entry by the General Land Office for a forest reserve, although previous reports that that section of Oregon would be withdrawn from entry have always met with strong protest. About 1,500,000 acres, extending from townships 31-39 West in Douglas county to the State line and from about 6 miles West of Grant's Pass down to within 6 miles of the coast are included.

The first large forest reservation made by a railroad company has also been established in California. The Southern Pacific Company has reserved 2 bodies of land in Oregon as a permanent railroad reservation of timber. One is located on the McKenzie and the Mohawk rivers, comprising 27,000 acres of railroad land, which does not include the intervening even numbered sections. Including the Government section the area would be 54,000 acres. The second and still larger reservation is in the hydrographic district comprising the headwaters of the Siuslaw. The latter reservation comprises 105,000 acres of railroad land, making, by inclusion of the accompanying Government land, 210,000 acres within the limits of the railroad reservation.

These reservations are the first that have ever been made by any railroad company as permanent forest reservations. The object is not to reserve the timber from use, but to apply to these forests a scientific system of forestry; that is, to cut the ripened timber in such a manner as not to interfere with the growth of the young timber, so

that there will be an annual new growth of these forests without changing the forested condition of the areas reserved.

#### NEW HAMPSHIRE FORESTS.

Heirs of the late Austin Corbin, of New York, have decided to practice forestry on the Blue Mountain Forest Park, near Newport, in Sullivan county, New Hampshire. The Blue Mountain Forest Park is one of the noted game preserves of the country. It contains 25,000 acres, and is stocked with a variety of wild animals, containing what is said to be the largest herd of pure bred buffaloes in this country, 128 head. Besides buffalo, the park contains wild boars from Germany, elk, moose and deer of several kinds. The owners of the park wish it to be maintained first of all as a game preserve; but they are also anxious that the timber be put in the best condition possible, and for that reason have decided to manage it according to principles of forestry. The park was established 12 years ago by the late Austin Corbin, who fenced it and stocked it with game. The long ridge of Croydon mountain runs through the tract, and on this ridge grows a forest composed of spruce and hardwoods. The spruce is now being lumbered under forest management. Old pastures in the tract, which are growing up to spruce, will be studied by Mr. Akerman and his party in order to devise ways of hastening the reproduction.

Another piece of forestry work in New Hampshire which will be undertaken by the Bureau of Forestry this summer is a working plan for the management of 3,000 acres of cut-over land on the Southwest slope of Mt. Moosilauke, in Grafton county, owned by the Pike Manufacturing Company. The favorable market conditions there offer an opportunity to show what forestry can accomplish on land from which the large spruce and other softwoods have been removed.—Exchange.

#### THE HISTORY OF MAPLE.

No other wood which has grown into general consumption in this country has had such a remarkable history as hard maple. From time immemorial maple, intermingled with hickory and beech, was regarded as firewood. It was the back log of our forefathers.

Only 15 years or so ago it was discovered that maple was a timber of quality; that notably in its green state it had wonderful breaking strength, and that, when seasoned, in its resistance to wear and abrasions it was not excelled by any wood in this country that grew in quantities. A fair proportion of the growth is figured in the form of birdseye or burl, and this fancy product of the forest was speedily depredated and placed in use in the production of furniture, car finish and interior house work. Then the agricultural implement people, builders of mowers, reapers, threshing machines, and wagon makers, took up the wood and made use of it extensively.

Only about 12 years ago hard maple entered as a notable factor in the flooring trade. For sev-

eral years thereafter it was not counted a success for this purpose, inasmuch as its difficult milling qualities and the inefficient machinery then made for its transformation into accurately manufactured flooring left the quality of the product far from desirable. Leading machinery makers of the country became interested in the possibilities of building a machine that could handle the wood and there were produced 4 side flooring machines of more than double the weight and strength formerly employed, with the result that soon high class machine work was accomplished.

The public, notably in the metropolitan districts, has taken kindly to maple as a flooring material and the sale of the flooring has increased steadily from year to year, until the present year's output will approximate 250,000,000 feet. Nearly all this product is used in high class building, warehouses, factories, public buildings and fine residences.—American Lumberman.

#### STATE STUDY OF FORESTS.

California is arranging for a thorough and comprehensive study of its forests to be prosecuted in connection with the Bureau of Forestry. The State has appropriated \$15,000 for the work, which is to be carried on in connection with forestry officials, with the understanding that the Forestry Bureau is to bear half the expense. The object of the appropriation is a thorough examination of the timber resources of the State and the establishment of reserves. The work will occupy several years and involve the expenditure of large sums of money. National and State reserves will be established and the work will be comprehensive and thorough and should do much toward providing for future lumber needs of the country.

#### FORESTRY SCHOOLS.

The collapse of the New York State school of forestry has by no means reduced the number of forestry schools, for several new ones have sprung into existence. Harvard University has organized a 4 years' course in forestry leading to the degree B. S. The University of Maine, at Orono, has instituted a chair of forestry and the University of Michigan has increased its teaching force, now having 2 professors. Our neighbor, Canada, also is beginning to move. After a fruitless wrangle between Toronto University and Queens University, in Kingston, Ontario, for government aid toward establishing a forestry school, the latter institution has decided to start one on its own account.

What do you write with when you are in camp? Anything so good as a Laughlin fountain pen? There is nothing better for the purpose. It is always ready when you wish to make a note or to write your friends what a good time you are having. Before you go into camp this fall send me 2 yearly subscriptions to RECREATION and I will send you a Laughlin fountain pen as premium.

## PURE AND IMPURE FOODS.

*"What a Man Eats He Is."*

Edited by C. F. LANGWORTHY, PH.D.

Author of "On Citraconic, Itaconic and Mesaconic Acids," "Fish as Food," etc.

### PREPARATION OF FOOD.

According to Professor W. O. Atwater, who has for a long time conducted important food investigation for the U. S. Department of Agriculture, the cooking of food has much to do with its nutritive value. There are 3 chief purposes of cooking. The first is to change the mechanical condition so that the digestive juices can act on the food more freely. The 2d is to make it more appetizing by improving the appearance and flavor. Food, which is attractive to the taste quickens the flow of saliva and other digestive juices, and aids digestion. The 3d is to kill by heat any disease germs, parasites, or other dangerous organisms the food may contain. This is important and applies to both animal and vegetable foods. The cooking of meats develops the pleasing taste and odor of the extractives, also that due to the browned fat and tissue; softens and loosens the protein (gelatinoids) of the connective tissues; and makes the meat more tender. Extreme heat, however, tends to coagulate and harden the albuminoids of the lean portions, and weakens the flavor of extractives. If the heating is carried too far, a burned or charred product of bad flavor results. Meats lose weight in cooking. A small part of this is due to escape of meat juices and fat, but the chief part of the material lost is water. The nutritive value of meat soup depends on the substances which are dissolved out of the meat, bones, and gristle by the water. In ordinary meat broth these consist almost wholly of extractives and salts, which are agreeable and often most useful as stimulants, but have little or no value as actual nutriment, since they neither build tissue nor yield energy. The principles which underlie the cooking of fish are essentially the same as with meats.

In many vegetables valuable carbohydrates, chiefly microscopic starch grains, are contained in tiny cells with thick walls on which the digestive juices have little effect. Cooking, especially with the aid of water, ruptures these walls and makes the starch more soluble. The heat also caramelizes a portion of the carbohydrates and produces agreeable flavors in this and other ways.

In breads, cakes, pastry, and other foods prepared from flour, the aim is to make a palatable and light porous substance, easily broken up in the alimentary canal. Sometimes this is accomplished by means of water and heat. The heat changes part of the water in the dough to steam, which, in

trying to escape, forces the particles of dough apart. The protein (gluten) of the flour stiffens about the tiny bubbles thus formed and the mass remains porous even after the steam has escaped. More often other things are used to raise the dough, such as yeast and baking powder. Baking powder gives off carbon dioxid and the yeast causes fermentation in the dough, by which carbon dioxid is produced. This acts as the steam does, only much more powerfully. When beaten eggs are used, the albumen encloses air in bubbles which expand, and the walls stiffen with heat, thus rendering the food porous.

Professor Atwater insists that scrupulous neatness should always be observed in keeping, handling, and serving food. If ever cleanliness is desirable, it must be in the things we eat, and every care should be taken to insure it for the sake of health as well as of decency. Cleanliness in this connection means not only absence of visible dirt, but freedom from undesirable bacteria and other minute organisms, and from worms and other parasites. If food, raw or cooked, is kept in dirty places, peddled from dirty carts, prepared in dirty rooms and in dirty dishes or exposed to foul air, disease germs and other offensive and dangerous substances can easily get in.

Food and drink may be dangerous purveyors of disease. The bacteria of fevers sometimes find their way into drinking water and milk, and bring sickness and death to large numbers of people. Oysters which are taken from the salt water where they grow, and floated a short time in brackish water near the mouth of a stream, have been known to be infected by typhoid fever germs, brought into the stream by sewage from houses where the dejections from patients had been thrown into the drains. Celery or lettuce grown in soil containing typhoid germs has been thought to convey this disease.

Food materials may contain parasites, like tapeworms in beef, pork and mutton, and trichinæ in pork, which are injurious and sometimes deadly in their effect. This danger is not confined to animal foods. Vegetables and fruits may become contaminated with eggs of numerous parasites from the fertilizers applied to them. Raw fruit and vegetables should always be thoroughly washed before serving, if there is any doubt as to their cleanliness. If the food is sufficiently heated in cooking, all organisms are killed.

Sometimes food undergoes decomposition

in which injurious chemical compounds, so called ptomaines, are formed. Poisoning by cheese, ice cream, preserved fish, canned meats, etc., has been caused in this way. The ptomaines often withstand the heat of cooking. In some cases it has been found that foods are adulterated with compounds injurious to health; but sophistication in which harmless articles of inferior cost or quality are added is more common.

Dainty ways of serving foods have a usefulness beyond their æsthetic value. Everyone knows that a feeble appetite is often tempted by a tastefully garnished dish, when the same material carelessly served would seem unpalatable. Furthermore, many cheap articles, when well seasoned and attractively served, may be just as appetizing as dearer ones, and will usually be found quite as nutritious.

#### WHOLE WHEAT, GRAHAM AND PATENT FLOUR.

The experiments with wheat milling products, which Professor Snyder has reported in a bulletin of the United States Department of Agriculture, are the latest of a series which has given uniform results. Some general deductions from the experiments seem warranted.

As shown by analysis, the patent flour ground from the hard and soft wheats had a lower protein content than the graham flour and entire wheat flour ground from the same wheats; but according to the results of experiments with the different grades of flour, the proportion of digestible protein and the available energy in the patent flour was larger than in the coarser grades. The lower digestibility of the protein in the latter is due to the fact that a portion of this constituent is contained in the bran and escapes digestion. Thus, while there may be actually more protein in a given quantity of graham or entire wheat flour than in an equal quantity of patent flour ground from the same wheat, the body secures less of the protein and energy from the coarse flour than it does from the fine, since although the retention of the bran and germ increases the percentage of protein, it decreases the digestibility. By digestibility is meant the difference between the quantities of the several nutrients consumed and the quantity excreted in the feces. No attempt was made to study the ease or rapidity of digestion of the different kinds of flour. When the digestibility of different grades of patent flour was studied, it was found that there was no marked difference between standard patent flour and the other patent grades. The digestibility of all these flours was found to be high, apparently because they were finely ground. Patent

flour is superior as regards digestibility, on account of its mechanical condition and physical properties.

In discussions of the comparative value of fine wheat flour and the coarser grades, it is often claimed that the larger proportion of mineral matter, especially the phosphorous compounds, in whole wheat and graham flours is a reason for preferring them to patent flour. It is undoubtedly true that the proportion of mineral constituents which the body can retain, from the different kinds of flour, must be considered, as well as the quantities which chemical analysis shows to be present in the food. As it is impossible by present methods to determine the true digestibility of the mineral constituents, no values for the digestibility of ash have been included in Professor Snyder's bulletin. When the coarser milling products are fed to cattle no great quantity of phosphorus, one of the most important manurial elements, is retained in the animal body. This may be an indication that the phosphorus, even if present in the feed, is not in a form assimilated by animals. This, however, is conjecture, and more experiments with man and the lower animals are needed before satisfactory conclusions can be drawn.

The most important deductions from the results of these later investigations with hard and soft wheat are in accord with the conclusions drawn from the earlier investigations of this series. The nutritive value of flour, in so far as the quantities of digestible protein, fats, carbohydrates, and available energy are concerned, is not increased by milling the wheat in such a way as to retain a large portion of bran and germ. The differences in the quantities of total nutrients furnished the body by the various grades of flour are, however, relatively small, all grades being quite thoroughly digested. The coarser flours have a tendency to increase peristaltic action, and are valuable for some persons. Judged by composition and digestibility, all the flours, both patent and coarser grades, are nutritious foods. They furnish nutritive material in an economical form, and the use of different grades of flour for bread making and other household purposes adds to the variety of the daily diet.

---

Build more fire under those swine. You don't cook them enough. Some of them get away with just their skin roasted. Leave them in the oven until they are thoroughly cooked. We have plenty of them here, but I think our new law, with several wardens to the county, will check them. They paid no attention to the old law, as we had only a State warden.

Charles Pettys, Kilgore, Idaho.

## EDITOR'S CORNER.

One Harry Gibson, of Cozad, Neb., took in some money last winter by killing prairie chickens and smuggling them through to Chicago under false labels. He, however, carried his operations too far, and deputy game warden Farrell learned of his illegal work. Farrell accordingly went on a still hunt for Gibson and ran him down. It seems that Gibson's mother had planned a visit to Chicago, and when her trunk was delivered at the station to be checked, Farrell demanded that it be opened for his inspection. This was done, and the trunk was found to contain a number of prairie chickens mixed up with Mrs. Gibson's night dresses, stockings, handkerchiefs, Easter hats, etc. Farrell took Harry to court and the justice assessed him \$150 and costs. Harry will have to invent some other scheme for getting his game out of the State in future.

John and Edward Swartz, Harry Kipp, Joseph Wheeler, Joseph McGhee and Frank Olridge were arrested at Pine Plains, N. Y., by State Game Warden Farley in May last, for spearing bass and pickerel in Mud pond. The Swartz brothers, Wheeler and Olridge were taken before a justice of the peace in Poughkeepsie for trial. Olridge and Wheeler were convicted and fined \$25 each and went to jail for 25 days. The Swartz brothers turned State's evidence and were allowed to go free. Joseph McGhee was fined \$50 and put up his money. Kipp has since been sent to jail in Hudson on a charge of burglary. All good people will regret that John and Edward Swartz should have escaped justice, yet there is great consolation in the fact that 3 of the gang are now looking through iron bars and that the State has obtained \$50 of good money from one of them.

Dr. A. W. Heitzig, of St. Louis, was arrested some weeks ago by deputy game warden Hasshagen and charged with killing song birds. The Doctor went into court, pleaded guilty and was fined \$5. My informant does not say what kind of birds the Doctor killed, and I do not, therefore, know what the legal penalty is, but it is safe to say that the justice of the peace did not probably appreciate the enormity of the offense. A man who has education enough to be a physician should certainly have sufficient respect for the laws to obey them, and that this man should have gone hunting for innocent songbirds should have led the justice of the peace to have

given him the limit. If some one will give me the name and address of that justice I will send him some literature that will enlighten him as to his duties regarding the game laws.

The Hon. L. T. Christian, a member of the Virginia Legislature, is another of the friends of game protection who does effective work for the cause. He made a valiant fight during the past winter and spring and has won out. The Old Dominion now has one of the best game laws in the Union, and while Mr. Christian had valuable assistance from a number of other members of the Virginia Legislature, the fact remains that he is entitled to the greatest credit for his splendid achievement. I trust every sportsman in the State may thoroughly appreciate Mr. Christian's work, and see to it that he is properly rewarded whenever he may again be before them as a candidate for any office.

Among others who share in the honors of the winter's work are W. D. Cardwell, of the House, and Messrs. Don P. Halsey and Geo. B. Keesell, of the Senate.

John Davit, George Ozzelo, Frank Rossett, Joe Moler and Andrew Ssiade were recently arrested by Game Warden H. Rief, of Seattle, Washington, for dynamiting trout in Cedar river. Mr. Rief took them before a justice of the peace, where they were convicted of the offense and heavily fined. Davit paid his good money into the State game fund, but the other 4 dagos went to jail. As has before been stated in RECREATION, Mr. Rief is a member of the League, No. 9151, and did valiant work at Olympia last winter in securing needed amendments to the Washington game and fish laws. He is a hustler and deserves the gratitude and esteem of every sportsman of Washington.

The Arkansas Legislature enacted some sweeping amendments to its game laws during the past winter. Under the new law non-residents are not allowed to hunt in that State at any time. The sale of game and the export of same from the State are prohibited at all times. The sheriffs, deputy sheriffs and constables are *ex officio* game wardens, and these officers and the game wardens are entitled to all fines collected for violations of game or fish laws. So it looks as if game might be allowed to exist in that State for a long time to come.

## THE COLONEL'S VICTORY.

A. L. VERMILYA.

"Go on, now, you garrulous mistake of humanity; you make me tired! Don't you know, Wiggles, that the songs of crickets and grasshoppers are several times more pleasant to listen to than your chatter? If you must bore someone with your silly cackle, try it on Starchy or the Chicken! They can't feel anything!" The Colonel resumed his reading, while the semblance of a frown touched, for a moment, his good natured face.

Wiggles looked reproachfully at the Colonel, and winked at Starchy and me. That is Wiggles' way, and a reproachful look is his strong point. He will pour out unmitigated twaddle until you have lost all patience, and then when you tell him what you think about it, he will turn on you an injured, sorrowful look that makes you feel as flat as a punctured tire.

There were 4 of us, and we were taking our annual vacation in a picturesque part of the country, about 30 miles from the city. We had pitched our tent close by a fidgety little stream, from whose foaming waters we drew fish of various kinds in plenty. It was an ideal place. To be sure, we had the regulation discomforts of the camper, such as mosquitoes, ants, rainy days, etc.; but we did not allow those things to bother us. We liked the country in general, and fishing and pottering about the water in particular.

The Colonel, Jones, by name, is a small, fat, jolly man, with as military a bearing as a cow has. His high sounding title never fails to draw a smile from strangers who for the first time hear it applied to him. Wiggles, whose real name is Will Leisaw, is a tall, athletic young fellow, light hearted and witty, but with an abnormally developed penchant for hectoring. When in the city, and in his right mind, he is a photographer, and a good one, too. Starchy, known to some as Sam Perkins, is tall, slim, and blue eyed. At home he operates a laundry, but this has nothing to do with his nickname. We call him Starchy because of his extremely neat and fastidious ways. As for me, my name is Smith, just plain Smith without any frills; and I am a clerk in a wholesale house. I am the oldest of the party, and have been dubbed the "Chicken." Why the boys gave me this name I do not know; perhaps they likened my light and easy bearing, to the vain and trifling manners of a pin-feathered product of the poultry yard. Names cut no johnny-cake anyway.

About a mile from our camp was the

sleepy little village of Wickers, containing, perhaps, 300 inhabitants, most of whom appeared to wonder how they got there. There were sleepy little stores containing fly-specked stocks which were never sold; a sleepy old tavern where nobody ever stopped; a sleepy little millinery store where a sleepy looking young lady with red hair and a sentimental smile built impossible hats and bonnets out of silks and ribbons of antiquated weave and delirious color; and there was a tumble-down shoemaker's shop where a dried-up little Englishman made caricatures of boots and shoes, and did cobbling for the sleepy villagers. How these somnolent citizens lived was a wonder to many, but the fact that a good sized river flowed calmly along one side of the village offered a partial solution to the vexed problem; for the visitor could not fail to notice that the fishing tackle shop was the most prosperous looking establishment in the town. Moreover, as the banks of the stream were usually dotted with anglers and as what the denizens of the village did not know about fishing was not worth bothering about, it was reasonable to suppose that the greater part of their sustenance was drawn from the river.

When Wiggles turned off his reproachful look, he again gave his attention to stirring up the Colonel.

"That's a pretty good magazine you're reading, isn't it, Colonel?"

"Of course it is," returned the individual addressed.

"Yes, I rather like it myself," said the imperturbable Wiggles, "and so do Starchy and the Chicken. Quite a magazine, I guess."

"You guess," said the Colonel, hopping up like a startled prairie dog. "You guess! Why, anybody with only half an eye and no sense at all ought to comprehend, just by looking at the Southwest corner of the back cover, that it's the best sportsmen's book published between Jerusalem and the Klondyke!"

"Quite a book is RECREATION," said Wiggles, winking at Starchy and me; "but there are others!"

"Now, see here, sonny,"—the Colonel was looking savage by this time—"I tell you there can't be others while this magazine is published! It's the whole thing. It's better reading than Robinson Crusoe, and its game pictures would bring a blind setter to a point." He held the book up by one corner and gazed affectionately at it.

"Well," said Starchy, "if RECREATION is such a hummer why don't you start out and canvass for it a while? People would fall over one another to subscribe for it."

"Canvass be blowed! I can get all the canvassing I want under that sun-baked, high-pressure, sub-tropical bit of duck over there!" He waved his hand in the direction of the tent, and cast at it a contemptuous look.

"But I'll tell you what," the Colonel continued, "if I wanted to take orders for this magazine, I could get 40 subscribers right over in Wickers! Yes, you bet your collar button I could!"

"Bet you a tenner you couldn't get 20."

"Done! Now dry up!"

The Colonel continued his reading unmolested, while the rest of us smoked, and overhauled our fishing tackle.

The next morning the Colonel started for Wickers as soon as we had eaten breakfast.

"I'll show you chaps," said he, "that even the Wickers folk know a good thing when they see it."

We offered to accompany him and give him our moral support, but he scorned the proposition.

"I know you fellows," said he. "About the time I should succeed in convincing a man that he could not do business without my magazine, one of you would chip in with some palaver, and upset the whole thing. I understand human nature and how to get on the right side of people, and you don't. You stay here and fish."

This was like the Colonel; he thinks he has all the wisdom of the sages, and a lot that hasn't yet been patented.

He was gone all day, and when he showed up about sunset, he was singularly reticent about his canvassing. When Wiggles tackled him about it, he merely said, he guessed he had done a fair day's work.

So he had. The next morning a bright lad who sometimes furnished us with bait, was over to the camp; and when the Colonel had betaken himself to his favorite haunts down the river, the boy told us all about it. He had happened to be in the store where the Colonel had tried to get his first subscriber, and as the show was eminently satisfactory, he had followed the amateur book agent on his rounds through the village.

The Colonel had first tackled the principal store, where a weather-beaten sign informed a credulous public that "Aaron Rush, dealer in dry goods and groceries," did business within. The proprietor was sitting on his front steps, sorting over some dried-up lemons and oranges.

"Good morning, Mr. Rush," said the Colonel, going straight at the business in hand; "I have here a sportsmen's maga-

zine which I should like to have you look at if you have time. Living in such a delightful region, you probably take an interest in hunting, fishing, and other outdoor sports, and——"

"Don't want it. Never hunt nor fish none, myself."

"But you may have a son who is a lover of Nature, and who would be glad to have you subscribe for him. Please look at it. Here, you see, are fine illustrations by the best photographers and artists in the country. Then the reading matter is far superior to that found in most publications of its class, while its various departments are replete with accurate and detailed information useful to everybody. Here, for instance, is a valuable article on foods. As a dealer in provisions, you will certainly be interested in this department."

"No use for it. Never read none myself, and don't see no good in it."

"But your wife might like it," persisted the Colonel. "RECREATION numbers a great many ladies among its regular subscribers."

"Now, see here, young man," said the merchant, tossing a decayed lemon into the street, "I've told you 2 or 3 times that I don't want your blanked magazine! Can't you understand?"

"Certainly, sir, but I thought perhaps you might change your mind after looking the book over."

"Well I never change my mind for nothing, specially for no dum book agent."

"Probably not. If you did change it occasionally, perhaps you might get a better one in the end." The Colonel was mad, and began to get reckless in his talk.

"Now look here, young feller," said the grocer, starting up: "I won't take none of your sass! You jest git out of here about as quick as you know how!"

"All right, I'm going. Guess there don't many people bother you. Now that I think of it, this is the place where I bought some wormy crackers and mouldy cheese, the other day. The fly-specks on your sugar barrels spell 'lonesome,' and the dust and cobwebs on your showcases remind me of the inside of a Digger Indian's hut." The Colonel went down the steps, leaving the worthy grocer purple in face.

"You—you—" was all he could say as he shook his fist at the offender. It is a wonder he didn't have an apoplectic fit.

"All right, Mr. Rush, all right!" said our depraved pard; "I understand what you mean. Good-by."

But the Colonel was game, and as the next place on his way was the millinery shop presided over by the red haired young woman, he dropped in to try his luck. Here, again, he met defeat; for the milliner could see nothing of interest in the magazine, and tee-heed at everything the Colo-

nel said. She had never thought it wrong for women to wear birds on their hats and didn't care what she used for trimming as long as it was becoming. For her part, she didn't care whether there were any birds or not, and was sure there would always be something nice to trim with. He left in disgust, and sought the shoemaker's shop, where he found the proprietor engaged in a game of checkers with the village schoolmaster. The little Englishman had been beaten 3 successive games by the pedagogue, and was not in a nice temper.

"Got more readin' stuff now than I know what to do with," he said when shown the magazine, "an' I never have no time for mopin' over books an' sech like, anyway. It's business with me, all the time." Business did not seem to be rushing that morning except in the checker line.

But the Colonel was on his muscle then, and for a plump hour kept the shoemaker from his beloved checkerboard, and drove him almost wild with a rapid fire explanation of the merits of RECREATION. He did not expect to get a subscriber, but was determined to make one person in Wickers listen to what he had to say. At last he stopped, and the little cobbler, rousing himself as from a dream, said:

"Now, gol dum me for a fool for wastin' my time on such blanked nonsense! I wouldn't take your cussed magazine if you'd give it to me."

"All right, Mr. Duff, but you must remember that I have wasted an hour talkin' to a chap 200 years behind the times." He rose to go, but in the doorway turned and said: "Better put labels on those boots and shoes of yours so that people will know what they are. Folks are likely to take them for specimens of Aztec pottery, crows' nests, stuffed woodchucks, or something of that sort!" Then the Colonel ambled away. It's a wonder, considering the way our reckless chum talked, that somebody didn't wipe the streets with him that day.

The canvassing business was looking rather slim to the Colonel, when suddenly a bright idea seized him. He is subject to such spells. The idea he had seemed to please him, and with a jaunty step he crossed the street to the tavern and entered the bar-room where were congregated 3 or 4 farmers and the regular complement of village idlers. With a winning smile on his face he called up all hands and bought the drinks, said drinks consisting only of some warm lemon pop and a potent article of whiskey. All but 2 of the assemblage took whiskey. Then everybody went out and sat on the piazza in the shade.

"What fine scenery you have about here," remarked the Colonel, "and what a chance

for all kinds of outdoor sports! I wonder more city people don't come here. Best of places for camping, boating, fishing, golf, etc."

A long, lank, chin-whiskered granger spat on an unoffending rosebush, and "lowed that they was a putty tollable chance for campin' round these parts."

"I don't believe the beauties of this locality have been properly advertised," pursued the Colonel. "If people knew more of this part of the country there would be plenty of campers here during the whole of the summer and fall. The farmers could get city prices for butter, eggs, milk, poultry, etc., and the people of this village would have a rushing trade in all lines. Now there is the 'Daisy Shooting and Fishing Club' of our city, with about 60 members. They leave town in September, and want a place nearer home than the one where they have formerly camped. There are plenty of other clubs, too, that would be glad to come here. The members of these associations are wealthy, and like to spend their money when they are out. If the people here are enough interested in the matter to build boats, furnish guides, etc., I shall correspond with the managers of these clubs, with a view to getting them to locate here. This is the reason I am canvassing for this sportsmen's magazine to-day. I wish to find out what the sentiment is here in regard to having these clubs come here for their annual vacation, and to this end I am looking up the sportsmen of the place. I am sure it would be to the interest of this town and surrounding country to have outsiders come here. Well, I must be getting back to camp."

He rose to go, when the long, chin-whiskered farmer spoke:

"What sort of a book is this here magazine you're a takin' orders for?"

The Colonel produced his samples, but did not have to do any talking. He secured 5 subscriptions on the spot.

On the morning of the second day after the occurrences just related, as we sat quietly fishing from the shore, a freckled frowsy urchin with a cedar fishpole and one suspender hove in sight. He came over to where we sat, and gazed intently at the Colonel.

"Say, mister," he said after a moment's hesitation, "you've got 'em."

"What is it, sonny?" said the Colonel, looking at the freckled youth in some surprise.

"I say you've got 'em, all right enough."

The Colonel looked at his bobber floating placidly in the stream, and then at the boy.

"What's the matter with you, kid?" he said. "What have I got?"

"The folks over in town,"



# Schlitz



THE BEER  
THAT MADE  
MILWAUKEE  
FAMOUS.

## There is no biliousness in old beer

The beer that makes you bilious is what we call a "green beer." It is beer that is marketed too soon — that is insufficiently aged.

We store Schlitz Beer for months in refrigerating rooms, and this fact requires a storage capacity for 425,000 barrels.

We keep it there until it is well fermented. That adds to the cost, of course. That is why some beers are shipped green.

## We are that careful all through

Careful about materials  
— about cleanliness.

So careful that we filter all the air that touches Schlitz Beer.

And when it is bottled and sealed, we sterilize every bottle.

Your doctor will tell you to drink Schlitz Beer, rather than common beer; and it costs you no more than the common.

*Ask for the brewery bottling.*

"Boys," said the Colonel, helplessly, "do any of you happen to know of a juvenile lunatic asylum hereabouts from which this deranged youth could have escaped? Sonny, try to tell us where you feel bad."

"Bad, nothin'!" said the freckled youth, disgusted at the Colonel's obtuseness; "it's that there RECREATION. All the folks up to town wants to take it."

A light broke on the Colonel's mind, and a grin spread over his face.

"Come here, laddie," he said; "I don't believe you have a very good outfit. Take this and buy a new rod and line, and some hooks that were made to fish with." He shoved a dollar into the hand of the urchin who, with a "Thank you, mister," started off in the direction of Wickers.

"Guess I touched them, boys," said the Colonel, as he yanked a perch from the water.

He had, for during the day our camp was visited by at least two-thirds of the population of Wickers. They came singly, in pairs, and by the dozen. They had aroused from their lethargy for the time, and had rosy visions of their little town surrounded by wealthy pleasure-seekers, to whom they could dispose of everything they wished to sell, at 3 or 4 prices. They looked on the Colonel as the promoter of the enterprise, and, naturally, wished to stand in with him. Among the first to subscribe was Mr. Rush, who, calmly ignoring his previously expressed opinion on the matter, paid for 2 subscriptions, with a patronizing air, and departed. Then came the red haired milliner who, with many simpers and tee-hees, forked over \$1. All day the money flowed in. The last to subscribe was Mr. Duff, the shoemaker. He was a little sore yet at the remarks the Colonel had made in his shop and the reflections cast on his boots and shoes still stuck in his crop.

A few days later, a check was sent the publisher of RECREATION, the amount of which, together with the accompanying list of more than 200 names, coming from so small a place must have knocked that hardy individual considerably out of line.

Over at the Colonel's home, in the city, is one of the finest pianos ever made; it is a premium for his day's hustling at Wickers.

What about the "Daisy Shooting and Fishing Club?" Well, there wasn't any such outfit. The Colonel drew on his vivid imagination for that little fiction; but it was all right. The people got their money's worth, and when the magazines were received, they forgot all about the camping clubs and the money they were going to make selling truck to the city folk. RECREATION just hypnotized them, that's the size of it! They soon relapsed into their former sleepy ways, and, being as slow at reading as they were at everything else, by the time they had finished one issue of the magazine another would show up, so they had no time to kick.

## TO MY DOG.

ROGER W. RHODES.

What say you, Rex, old fellow, does it make your pulses beat,  
Just to think of days fast coming—days of autumn; cool and sweet—

When October's frosts are painting all the woods with colors gay,  
And the grouse is drumming loudly on the hilltop far away?

Does it make you thrill with gladness as across the lawn you glide,  
Just to think of some gray morning on the sun-kissed mountain side,  
When Sir Reynard, softly stealing from his den, on breakfast bent,  
Leaves behind, on grass and stubble, such a strong, alluring scent?

And what say you, Rex, companion on so many a hard-run chase,  
Does your heart not bound within you as I look in your bright face,  
Calling to your mem'ry pictures of those bygone happy days—  
Scenes to be re-enacted 'neath October's golden haze?

Hold yourself in patience, comrade, just a few more days must fly;  
Then we'll rise some morn at daybreak—two blithe hunters, you and I.  
Forth into the dawn we'll sally, with the old gun—still, of late—  
Once again we'll hear its music—say, old fellow, can you wait?

The 22 long Winchester smokeless is one of the best cartridges for shooting woodchucks, squirrels and grouse, as it makes little noise, no smoke, and gives penetration enough at 100 feet to do the work. As a target cartridge it is extremely accurate up to 150 feet.

What are the merits of the 44 Winchester rifle cartridge?

Dimon Lockwood, New York City.

I am glad to learn that you are reaping a good reward for your efforts, and as you have succeeded in placing before the sportsmen of America the best of all magazines, I trust that your good fortune may continue, and that RECREATION may long flourish to cheer the hearts of all true lovers of legitimate sport.

R. H. Mertz, Butte, Mont.

I shoot a Colt 22 rifle and an Iver Johnson shot gun. Both are all right. I have shot Winchester shells and cartridges and they either rip open or burst at the ends. Soak the game hogs right and left.

A. O., Grand Forks, N. D.

The Agent: I have a chronometer here which records the millionth part of a second.

The Busy Man: I haven't that much time to give you.—Yonkers Statesman.

# THE EQUITABLE

HENRY B HYDE  
FOUNDER

J.W.ALEXANDER  
PRESIDENT



J.H.HYDE  
VICE PRESIDENT

*"Like leaves of trees the race of man is found,  
Now green in youth, now withering on the ground"*  
— Pope

## FALLING LEAVES

warn us that winter-time is fast approaching. And we prepare for it.

But how about the winter-time of life? When the winter of your life approaches, will it be bare and cheerless as that of the tree stripped of its leaves?

An adequate Endowment policy in the Equitable makes a sure provision for your maturer years,— and meanwhile will protect your family.

*Vacancies for men of character to act as representatives*

Apply to GAGE E. TARBELL, 2ND Vice President

For full information fill out this coupon or write

**THE EQUITABLE LIFE ASSURANCE SOCIETY of the United States**

120 Broadway, New York Dept. No. 16

Please send me information regarding an Endowment for

\$.....if issued at.....years of age.

Name.....

Address.....

## AMATEUR PHOTOGRAPHY.

"For sport the lens is better than the gun."

*I wish to make this department of the utmost use to amateurs. I shall, therefore, be glad to answer any questions and to print any items sent me by practical amateurs relating to their experience in photography.*

### 8th ANNUAL COMPETITION.

RECREATION has conducted 7 amateur photographic competitions, all of which have been eminently successful. The 8th opened April 1st, 1903, and will close November 30th, 1903.

Following is a list of prizes to be awarded:

First prize: A Long Focus Korona Camera, 5 x 7, made by the Gundlach Optical Co., Rochester, N. Y., fitted with a Turner-Reich Anastigmat Lens, and listed at \$85.

Second prize: A No. 3 Folding Pocket Kodak, made by the Eastman Kodak Co., Rochester, N. Y., fitted with a Bausch & Lomb Lens, Plastigmat Unicum Shutter, and listed at \$61.50.

Third prize: A Royal Anastigmat Lens, 4 x 5, made by the Rochester Lens Co., Rochester, N. Y., listed at \$36.

Fourth prize: A Waterproof Wall Tent, 12 x 16, made by Abercrombie & Fitch, New York, and listed at \$32.

Fifth prize: An Al-Vista-Panoramic Camera, made by the Multiscope and Film Co., Burlington, Wis., and listed at \$30.

Sixth prize: A No. 3 Focusing Weno Hawkeye Camera, made by the Blair Camera Co., Rochester, N. Y., and listed at \$27.50.

Seventh prize: A high grade Fishing Reel, made by W. H. Talbot, Nevada, Mo., and listed at \$20.

Eighth prize: A Tourist Hawkeye Camera, 4 x 5, and made by the Blair Camera Co., Rochester, N. Y., and listed at \$15.

Ninth prize: A Bristol Steel Fishing Rod, made by the Horton Mfg. Co., Bristol, Conn., and listed at \$8.

Tenth prize: A pair of High Grade Skates, made by Barney & Berry, Springfield, Mass., and listed at \$6.

The 10 next best pictures will each be awarded one dozen 8 x 10 Carbutt Plates, made by the Carbutt Dry Plate Co., Wayne Junction, Philadelphia, Pa.

The 10 next best pictures will each be awarded one dozen 5 x 7 Carbutt Plates.

The 10 next best pictures will each be awarded one dozen 4 x 5 Carbutt Plates.

A special prize: A Goerz Binocular Field Glass, listed at \$74.25, will be given for the best picture of a live wild animal.

Subjects are limited to wild animals, birds, fishes, camp scenes, and to figures or groups of persons, or animals, representing in a truthful manner shooting, fishing, amateur photography, bicycling, sailing or other form of outdoor or indoor sport or recreation. Awards to be made by 3 judges, none of whom shall be competitors.

Conditions: Contestants must submit 2 mounted prints, either silver, bromide, platinum or carbon, of each subject, which, as well as the negative, shall become the property of RECREATION. Negatives not to be sent unless called for.

In submitting pictures, please write simply your full name and address on the back

of each, and number such prints as you may send, 1, 2, 3, etc. Then in a letter addressed Photographic Editor, RECREATION, say, for instance:

No. 1 is entitled ———.

Made with a ——— camera.

——— lens.

On a ——— plate.

Printed on ——— paper.

Length of exposure, ———.

Then add any further information you may deem of interest to the judges, or to other amateur photographers. Same as to Nos. 2, 3, etc.

This is necessary in order to save postage. In all cases where more than the name and address of the sender and serial number of picture are written on the back of prints I am required to pay letter postage here. I have paid as high as \$2.50 on a single package of a dozen pictures, in addition to that prepaid by the sender, on account of too much writing on the prints.

Any number of subjects may be submitted.

Pictures that may have been published elsewhere, or that may have been entered in any other competition, not available. No entry fee charged.

*Don't let people who pose for you look at the camera. Occupy them in some other way.* Many otherwise fine pictures have failed to win in the former competitions because the makers did not heed this warning.

### WARM WEATHER WORK.

The amateur who does much photographic work during the summer finds that as the temperature rises his troubles increase and that plates, paper and solutions develop unexpected peculiarities, so that it sometimes seems almost impossible to do satisfactory work.

One of the most exasperating mishaps which may occur during hot, damp weather is the sticking of the paper to the plate or film during printing. It may result from a number of causes. A trifle too much glycerine in the solution used for soaking films causes the paper to stick as soon as it touches the film; and if film and paper are left in contact for any length of time a dirty yellow stain will be found on the film.

A drop of water accidentally spattered on the film side of a negative will soften the gelatine and cause the paper to stick firmly to it, so that when one tries to remove the print, it is necessary to tear it off, leaving a piece of the paper sticking on the film. A negative in this condition is useless for printing purposes and the question at once arises as to the best means of removing the stain. There are 2 methods by which this may be accomplished. The amateur

should first try soaking the stained plate or film in a fairly strong solution of sodium hyposulphite. An ordinary fixing bath will do, but it should be freshly made and kept cool while in use, as a gelatine film will dissolve just as readily in a warm hypo solution as in any other liquid. As soon as the stain is discovered on the plate the remedy should be applied, as a fresh stain is much more easily removed than one which has stood some time. The stained film will require several hours' soaking, but no trouble will follow even if the negative be left in the hypo bath over night. There may be some slight general reduction of density in the negative, but this will not be great enough to do any harm.

In case the foregoing method should not remove the stain, try a weak solution of cyanide of potassium, say 10 or 15 grains to one ounce of water. Soak the stained negative thoroughly to soften the film. Then, with a ball of cotton wool, wet with the cyanide solution, go over the negative, rubbing the stained part well. This solution has a reducing action on the negative, and its effect should be carefully watched. As soon as the stain has disappeared, wash the negative well and dry as usual.

Cyanide of potash is a violent poison and extreme care should be taken not to get it on the hands, especially on any cuts or scratches. Hold the plate away from the face while swabbing it with the solution; or, better, work in a current of air. When you have finished with the solution throw it away at once and lock up any of the chemical which you may have left.

C. M. Whitney, Bayonne, N. J.

AMATEURS OUGHT TO KNOW.

Sometimes a brown, or sepia, tone is more desirable than the regular blacks, as produced on the ordinary developing papers. A black print may be changed to a sepia by the following treatment: After the print is well washed, to free from hypo, bleach with

- Bichloride mercury . . . . . 1/2 ounce
- Chloride ammonium . . . . . 2 drams
- Water . . . . . 10 ounces
- Immerse for 3 minutes in—
- Chloride ammonium . . . . . 1 ounce
- Water . . . . . 20 ounces

Wash 5 minutes and darken with hypo solution, one dram hypo to one pint water.

Lenses are deceptive, apparently looking clean, but by rubbing the face of one with clean tissue paper, or linen handkerchief, a veil will be removed, which would lessen the speed of the lens.

Dirty bottles and trays, that can not be cleaned by the ordinary methods, can be readily cleansed with hydrochloric acid.

For use it should be diluted with an equal quantity of water.

A bottle of 10 per cent bromide potassium should be in every dark room, in case of excessive over exposure. A drop or 2 added to the developer under such circumstances will often save a plate that would otherwise have been worthless. A fountain pen filler is useful to control the drops.

Most amateurs, after using a tray, dump the contents and set the tray away to dry. The next time the tray is used it is merely rinsed and the chemicals that have become crystallized are not removed. The consequence is that when prints are made, stains, streaks and all kinds of trouble appear, and the maker of the paper is blamed for bad paper. Wash trays thoroughly, before and after using.

Printing from wet negatives can easily be done with a little care in handling the negative. After fixing wash the negative under the tap for a few moments. Wet thoroughly a sheet of any developing paper, slip the negative under the paper, and place face to face. Wipe off the water on the glass side of the negative and expose the negative in the regular way, but the exposure should be increased 25 per cent.

R. S. Kaufman, Wilkes Barre, Pa.

WANTS THE WHOLE STORY.

RECREATION'S photo department is excellent, yet I think it would be better if its contributors described their methods with greater detail. They tell how they proceed after exposing a plate, but say nothing as to how the exposure was made. Photos of birds and animals are interesting and valuable in proportion as they are difficult to obtain. I have done some work in this line. It requires much time and patience, and failures greatly outnumber successes.

I once attempted to photograph a lark on its nest in an open meadow. The bird flew as often as I approached within 5 rods, and would not return while I remained in the field. How could a picture be secured under such conditions? I know it is sometimes done.

Another time I found a robin's nest 12 feet above the ground. The bird would fly when I came nearer than 15 feet. I lashed sticks to the legs of my tripod to raise the camera to the level of the nest, set it at the 5 foot mark, set the shutter at 1-5 second, and used largest opening. Though I was using 25 feet of tubing, I had to wait 2 hours for the robin to return to the nest. When I finally made the exposure the bird flew at the first click of the shutter. I developed the plate and found the depth of focus only 3 or 4 inches. My next attempt was made at 4.30 a. m. I set up the camera as before, but put it 4 feet from the

birds, used stop 128 and set shutter on time. The bird came on the nest as soon as I had things fixed, but flew when shutter opened. I quickly closed the shutter and, the next time, let the bird sit 20 minutes before I pressed the bulb. That time she stayed. I exposed 25 seconds and secured an excellent negative.

What we most need is an absolutely noiseless shutter; one that can be sprung with a thread if necessary. We also need a tripod that can be extended at least 12 feet.

W. D. Gay, Essex, Ia.

#### SNAP SHOTS.

I use disco gelatine paper, and have been washing my prints in water from a well. The results were satisfactory, and I noticed that the first few changes of water always became milky in appearance. Recently the well failed and I have since used hydrant water. I have tried it both boiled and distilled, but in neither case does it discolor when prints are washed in it. The toning bath, however, turns milky, which it did not do when well water was used. Will these later prints be as permanent as the others? A local professional and an editor of a photographic journal, whom I consulted, say they will be as permanent; but a recent article by a professional contravenes their opinion.

J. R. H., Johnstown, Pa.

ANSWER.

Use distilled water and you will be on the safe side. Your professional friend and the editor of the journal were correct.—EDITOR.

What is the best coating or sizing preparation for a cloth bellows that is worn enough to admit light?

F. H. Evans, Kalamazoo, Mich.

ANSWER.

Pegamoid or any of the opaque waterproof varnishes might be tried, but would certainly crack in a short time. In emergency, Johnson's adhesive plaster can be used to advantage on the broken places. Pliable black cloth, not too heavy and properly cut, can be glued over the broken places with more or less satisfactory results. Thin leather can be used for same purpose. It would probably save time and money to get a new bellows.—EDITOR.

Can you give me a formula for reducing negatives? I have had lots of trouble getting negatives thin enough to print from. I leave them in the sun a whole day.

A. V. Woodcock, Hustontown, Pa.

ANSWER.

Do not carry negatives so far in the development.

To reduce: Soak well half an hour in cold water. Then place negative in a 10 per cent. solution of red prussiate of potash, rocking the tray during the reduction. Examine the negative every few moments to watch its progress. When sufficiently reduced, wash 15 minutes.—EDITOR.

For a combined hydroquinone metol developer, take—

Metol .....	50	grains
Hydroquinone .....	50	"
Sulphite of soda.....	11	drams
Soda carbonate .....	9	"
Potassium bromide.....	16	grains
Water .....	30½	ounces

The metol must be thoroughly dissolved before the soda carbonate is added. The developer works quickly.—The Photo-American.

An interesting bath for producing warm tones on bromide paper is described in *Der Amateur Photograph*. First bleach the print in a solution of potassium bichromate 150 grains; hydrochloric acid 150 minims; water 15 ounces. Then soak in a bath of ordinary alum until the yellow color is removed, wash well, and treat with a 10 per cent. solution of ammonium sulphide till sufficiently dark. Wash well.

I have been taking RECREATION a year and desire to express my appreciation of the many good things I find in it each month. I take 2 magazines devoted to photography exclusively, yet in the small space you devote to that subject I have found more of value than in the other 2 publications.

J. B. Burnley, Mexico, N. Y.

A professional photographer and dealer in cameras here says he would use a fixed focus lens in his studio if he could find one suitable. He claims they will do better and faster work than either a single or double rectilinear. Do you think he is right?

A. J. Perrine, Indianola, Ind.

I advise Ed. Dunn, of Iowa Falls, Ia., to get a \$20 4 x 5 Eastman plate and film camera. Both plates and films are handy to use at times. He can do better for \$20 in any 4 x 5. A 5 x 7 is still better.

Chas. Vitous, East Pittsburg, Pa.

I agree with Charles Metz that it would be well to have a RECREATION camera club. I know many camera owners and I think all would like to join a club of that kind.

W. O. Hall, Kittery Point, Me.

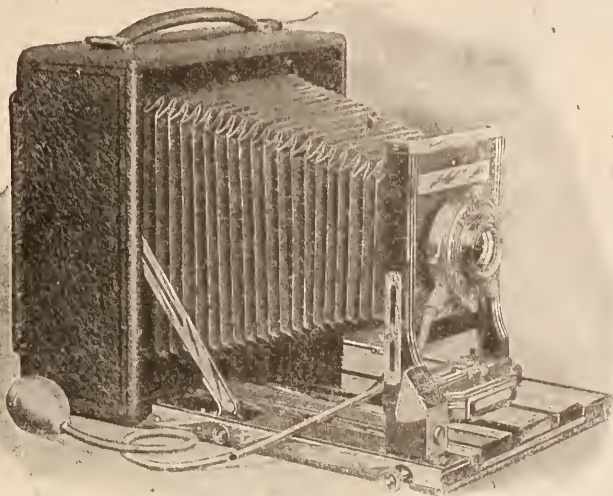

When you see a camera with the name "Century" on the front, you are looking at an instrument that is made on honor.

"Centurys" are the recognized Standard Cameras of to-day. To prove our claim that

## Century Cameras

are superior in design, finish and construction to any others in the market—*without a single exception*—we simply invite a careful comparison and trial. The new and exclusive Century features are *real* improvements, which mark a decided advance in camera building. Our new catalogue tells all about them. Copy can be obtained from your dealer, or direct by writing the manufacturers,

CENTURY CAMERA CO., Rochester, N. Y.

OBJECTS WELL CENTERED AND CORRECTLY FOCUSED

## The Focusing Weno

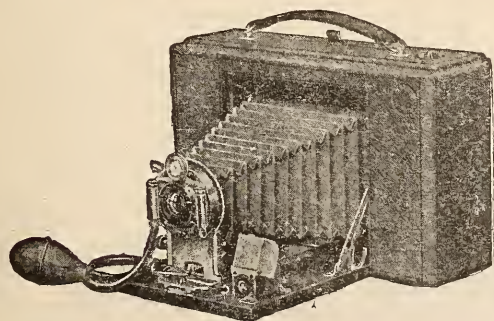

## Hawk-Eye

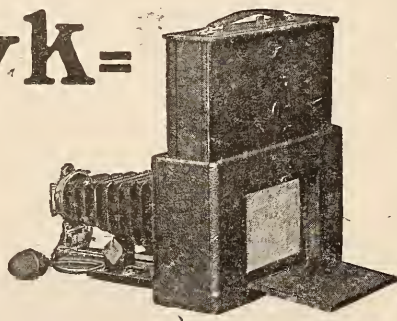

has the advantage  
over all cameras

of a ground glass the size of picture, which works automatically and allows focusing when using film. The result is obvious—perfection of work—satisfaction to the user.

No. 3 Focusing Weno Hawk-Eye, with B. & L. Automatic Shutter,  
and Extra Rapid Rectilinear Lens. Pictures  $3\frac{1}{4} \times 4\frac{1}{4}$ , " - - - \$27.50

No. 4 Focusing Weno Hawk-Eye, same equipment. Pictures  $4 \times 5$ , 30.00

Hawk-Eye Film can be developed in the Kodak Developing Machine.

Write for Hawk-Eye Booklets.

BLAIR CAMERA CO., Rochester, N. Y.

# It's Not a Toss-Up



as to the quality of pictures made with a  
**KORONA Camera**

**GUNDLACH-MANHATTAN OPTICAL CO., 730 So. Clinton Ave., Rochester, N. Y.**

An entirely novel utensil for use in the camp or the kitchen is the Duplex fork, made by E. A. Lyford, Cincinnati, Ohio, and designed for the lifting of hot food. This fork is constructed on the principle of certain curling tongs. It has 2 sets of tines, which are always open unless closed by a slight pressure on the handle. These tines are wide and flat, so they will not break the mealiest potato, but will grasp it with exactly the right firmness to lift it whole from boiling water. The fork is light, and will not rust. It should prove invaluable to any cook, whether in the camp or the home, and the price is only 25 cents. For further particulars, see Mr. Lyford's

ad in RECREATION, and in ordering a Duplex fork please mention this magazine.

I acknowledge receipt of the Ithaca gun and tender you my sincere thanks for it; also for the kind treatment you have accorded me. I used the gun on a short trip last week, and it exceeded my expectations. It comes fully up to and even exceeds the claims of the manufacturers. They should have the thanks of sportsmen for placing such a superior gun on the market at such a reasonable price, and for their promptness and courtesy.

Arthur Thomson, San Antonio, Tex.

**For Golf & Tennis Players**

**"PRESTO! - CHANGE!"**

ATTACHABLE EYEGLASS TEMPLES



Eye Glasses into Spectacles. Spectacles into Eye Glasses

**BE PROTECTED!**

**DON'T BREAK OR LOSE YOUR GLASSES IN EXERCISE, WIND AND STORM**

Can be attached by anyone

Send thickness of lens when ordering by mail

Price in Nickel 50c. a pair.

Gilt 75c. a pair.

Gold Filled \$1 a pair.

Solid Gold \$2.50 a pair.

Established 1842

GALL & LEMBKE, Dept. C, 1 W. 42d St.

21 Union Sq., New York

Send for Circular





## PHOTO POINTERS.

M. Sollet, in his new book, gives the following formula for sensitizing postcards:

Distilled water ..... 1 ounce  
 Silver nitrate ..... 45 grains  
 Uranium nitrate ..... 450 grains  
 Ninety per cent. alcohol to..... 4 ounces

Apply to well sized paper. It gives a brown image to be fixed in weak hydrochloric acid.

A modification of Farmer's reducer is recommended by Dr. Shirenburg, which consists of 3 solutions as follows: One containing 5 per cent. of hypo, another 5 per cent. of hypo and 10 per cent. sodium carbonate, and the third 5 per cent. of potassium ferricyanide. The addition of the second solution to the usual mixture of the other 2 makes it slower in working, and tends to prevent any yellow staining of the film.

There are 2 methods for restoring faded prints, both relying on the conversion of the image into a chloride and redeveloping. The prints must be removed from their mounts, then immersed in either of the following:

Mercuric chloride, 5 grains or... 10 g.  
 Hydrochloric acid, 1 minim or... 2 c.c.  
 Water, 1 ounce or.....1,000 c.c.

Potassium bichromate, 10 grains or 20 g.  
 Salt, 15 grains or..... 10 g.  
 Hydrochloric, 5 minims or..... 10 c.c.  
 Water, 1 ounce or.....1,000 c.c.

Leave the print in till thoroughly bleached, wash well for at least an hour in running water, then expose to daylight, and redevelop with hydroquinone, metol, or one of the newer developers, and the result is a black image.—The Photo-American.

It has been demonstrated that running water is not so sure a means of thoroughly removing the chemicals from prints as is the process of changing them from one tray to another. To do this as it should be done, the prints should be allowed to soak at least 10 minutes in each fresh water, handling them one at a time from tray to tray and pushing each print well under the surface as the change is made. Twelve changes made in this manner will remove as much as can be removed by several hours of treatment in running water. The same course should be pursued with plates, except of course each plate must have its own tray.

For bromide prints that curl up and become hard and unyielding, the same remedy will give relief. Soak the finished print in a mixture of glycerine 5 ounces and water 24 ounces, and all trouble will come to an end. When dry, they will lie flat, be flexible, and lose their stiff, refractory character.—Exchange.

## A New Folding POCKET KODAK

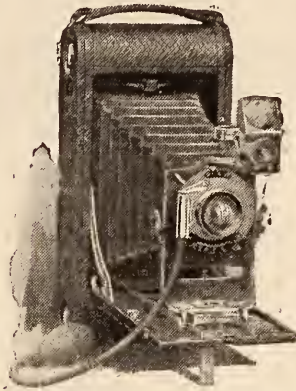

### THE No. 3A

Broader  
in scope  
than any-  
thing heretofore attained  
in Pocket Photography.

Takes pictures of new size  
and shape,  $3\frac{1}{4} \times 5\frac{1}{2}$  inches.

PRICE, - - \$20

Kodak Developing Machine for No. 3A, \$7.50

EASTMAN KODAK CO.

*Kodak Catalogue by mail  
or at the dealer's.*

ROCHESTER, N. Y.

# ROTOX

PRINTS IN ANY LIGHT

From each dozen sheets of ROTOX developing photo paper you can surely obtain twelve perfect prints. It prints from negatives too thin for other papers; is easier to manipulate and has a range of latitude that is unequaled.

#### PLATINUM BLACKS

Prices, per dozen, thick or thin, rough or smooth: 4x5, 15 cents; 5x7, 30 cents; 6½x8½, 55 cents; 8x10, 70 cents.



"ROTOGRAPH," *the best bromide paper, same prices.*

Sample copy of the *Photo Critic*, containing, every month, articles on "The A to Z of Photography." Of interest to amateur and professional, sent FREE.

Subscription, \$1.00 per year. Write  
ROTOGRAPH, Dept. V, 101 5th Ave., New York City

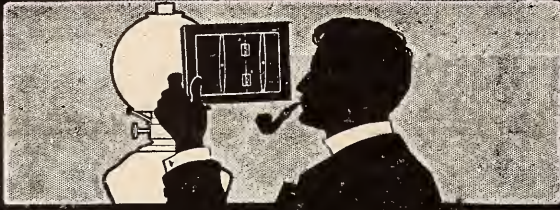

# VELOX

## LIQUID DEVELOPER

Made especially for Velox by the Velox people—it makes Velox better than ever—and that is saying a great deal.



Look for this label.

Four-ounce bottle Concentrated Solution, 25 cents.

ALL DEALERS.

NEPERA DIVISION,  
EASTMAN KODAK CO.,

Rochester, N. Y.

## OIL PORTRAITS ON APPROVAL.

If you will send me a photo of yourself or a friend and state color of hair, eyes and complexion I will paint and send you on approval a miniature oil or pastel portrait.

Canvas 6x8 or 8x10 inches, \$10.00

Canvas 10x12 or 12x14 inches, \$15.00

Z. EMMONS, 58 West 104th St., New York.

Reference: Mr. G. O. Shields.

## LANTERN SLIDES COLORED SKILLFULLY AND ARTISTICALLY FOR Lecturers, Teachers and others

I refer by permission to the Editor of RECREATION

**MRS. C. B. SMITH**

608 W. 115th Street, New York City

Old printing frames make good frames for pictures if stained brown or green.—Exchange.

## UNDER EXPOSED NEGATIVES.

Soak the finished negative, after fixation and thorough washing, in the following solution:

Potassium bichromate.....	1 part
Hydrochloric acid.....	3 parts
Alum .....	5 parts
Water .....	100 parts

In this the negative turns white, and care should be taken that it bleaches thoroughly both back and front. Next, the negative must be most thoroughly washed and then redeveloped with an old hydroquinone or ferrous oxalate developer. This is the important point in this process, for development must only be carried on till the details in the shadows are fully developed, and not till the high lights are developed right through, or, in the latter case, no improvement will be seen. As soon as the details in the shadows and half tones are developed, the plate may be rinsed and re-fixed. There being still some undeveloped chloride of silver at the back of the dense parts, fix this out, and the negative will be found by no means so hard as before.

This process intensifies the shadows, though, strictly speaking, this is only true when the bleached plate is exposed to daylight for some time and then developed, the chloride of silver image then being converted into a more non-actinic character than previously.—Exchange.

## DON'T FORGET

# Recreation's Photo Contest

**T**HIS is the time of year to secure photos of **Live Wild Birds and Game, of Camping Scenes or Other Outdoor Sports.** One such picture may win for you a valuable

**CAMERA,  
LENS. TENT,  
FISHING ROD,  
FIELD GLASS**

or other prize.

See announcement of contest in **RECREATION**, department of Amateur Photography.

## A JOINTED SNAKE.

Editor Scientific American:

I was raised on a farm in Missouri, where, when a boy, I killed many snakes of various kinds. Among them was what was known to me as the joint snake. When struck, it would fall into sections about 1½ inches in length. The head end, about 4 inches long, would run away and hide until it thought danger had passed. Then it would return, gather up the broken sections and be as good as new. In discussing snakes with a friend, I have been unable to convince him that there is such a thing as a joint snake. Will you look the matter up, and give it space in your next issue?

N. S. Donnelly.

## ANSWER.

Our correspondent refers to a creature which has puzzled many an observer and given rise to as many stories as the milk snake and the "toad in the solid rock." A large percentage of the farmers of the country believe there is a jointed, or glass, snake, which can disjoint itself and break up, to come together later; and it is difficult to find a country boy who will not testify that he has seen the miracle; and the most interesting feature is that they all firmly believe it. To give the deluded ones credit, the actions of the jointed snake are so remarkable that there is little wonder the sharpest observer is deceived; but there is a vast difference between what one really sees and what one thinks he sees, and herein lies the mystery of the jointed snake.

There is no animal known to science as a jointed snake. What the credulous observer believes to be such is a lizard, *Opheosaurus ventralis*; a well known low form common East of the Mississippi river and South of the Ohio. That it is considered a snake is hardly to be wondered at, as it has no feet; and when alarmed, darts away with the peculiar gliding or wriggling motion of a snake, and to any but a naturalist it would, doubtless, be considered a snake. But the animal is a lizard, and the long cylindrical tail, twice as long as the body, to the untrained observer appears to be the body. This slender tail is the cause of the many fables regarding the marvelous powers of the glass snake, which is so brittle that it can not be touched without breaking. The fact is that the vertebræ, or bones of this long tail, are so delicately connected that it is almost impossible to lift the animal by it without breaking it. Any violent jerk or strain will throw the tail into one or more pieces, which lie on the ground wriggling with a convulsive movement, while the head and body crawl away. It is not the body of the lizard, but its long tail which breaks up, a common trick among lizards. The tail thus thrown off is deserted, the lizard having no more power to reattach it than has a man to reassume his amputated leg. But the lizard has this advantage: a new tail begins to grow at once, and the glass snake is in a short time itself again, and may break up and be renewed an indefinite number of times, as far as known. In a collection of lizards caught at random in San Gabriel valley, Southern California, 50 per cent. had new tails in all stages of growth from one to 4 inches in length, being darker and readily recognized as new and growing tails. This faculty of reproducing lost parts or limbs is common among crustaceans and the casting of tails is so deftly carried out among lizards that the conclusion is irresistible that it is intended to deceive the pursuer or enemy. Another glass snake is the lizard of the genus *Anguis*. The blind worm often throws off its tail at the slightest danger, and it is almost impossible to catch and retain one without the loss of this member.—Scientific American.

I received the RECREATION match box O. K. All of Marble's goods are fine. The knife you sent me one year ago I would not part with for any price if I could not get another.

H. S. Johnson, Villa Grove, Colo.



# CYKO

## A NIGHT PRINTING PAPER

Cyko is the Most Perfect of all Developing Paper

### NO DARK ROOM REQUIRED

Easily manipulated and absolutely permanent

Produces Exquisite Effects in Black and White

Made in Six Different Grades

One Dozen 4 x 5 Cyko with Developer  
20 Cents

If your dealer cannot supply you send to

**THE ANTHONY & SCOVILL CO.**

122-124 Fifth Avenue  
NEW YORK

Atlas Block  
CHICAGO



**T**AKES everything within half a circle, making a picture five inches high by twelve inches long; or you can stop the revolving lens at different points and make exposures either four inches long, or six inches, or ten, depending upon how much you want to get in the picture. No wasted film. The revolving lens moves at different speeds, so you can gauge your exposure accurately. The exposure of the film is on the same principle as the focal plane shutter for pictures of moving objects. Our catalogue tells of its many uses—free.

**MULTISCOPE & FILM CO., 136 Jefferson St., Burlington, Wis.**

# AL-VISTA PANORAMIC CAMERA



## THE HEIGHT OF ART in camera work

Perfection in photography, has been secured by the use of the Al-Vista Camera. It produces the entire panoramic view — **from the limit of vision on the left to the extreme point on the right.** The Al-Vista Camera is compact: easy to use, sure in action. It is sold on its merits: we demonstrate this by selling you one

## on easy payments

Ask us for a catalog: select the camera you wish, fill up the blank we shall send you, and references being satisfactory we will at once send you a camera—pay weekly or monthly in sums to suit your purse. The camera is no longer a luxury: the demands of modern progress make a good camera a necessity; we make it easy for you to get the best, an

## Al-Vista.

*The*

## Multiscope & Film Co.

136 Jefferson St.

Burlington, Wis., U. S. A.

## A PIPE DREAM.

H. S. PETERSEN.

In the fall of '69 me and Jim Pardee, my partner, were camped in a shack on the West fork of Clark's fork of the Columbia. I had just cut my wisdom teeth and was as spry as a weasel, and as springy as a steel trap. I could follow a track through the brush as slick as a hound, and pull the tail feathers out of a cock grouse at every jump.

Jim was an old Hudson Bay trapper. He stood 6 feet in his moosehide moccasins and had a wart on his nose, which he used as a tang sight along the gleam of his old Kentucky rifle. That rifle was the masterpiece of a son of a gunsmith, and the pride of Jim's heart. Its barrel was convertible into a crowbar to pry a boat over sandbars. It carried a 10 to the pound soft nose slug, and when Jim drew a fine bead over that wart he could hit the center of a goat at 400 yards.

We were waiting to lift out a pack of peltries over the rise of the Bitter Root before the sleet flew. We made a right smart catch in the start and were kept going on the line. Jim worked the high ground for sign of fox, lynx and marten, while I picked the trail of the otter to his den or slide.

When, as often happened, we were caught out on the line, we would cut browse, and camp. A good trapper has not much use for a gun. He packs an ax, traps, spindles for snares, bait bag, knife and matches. Then, if he catches anything, he is in trim for a good load. Not a thing wears hair or sheds feathers that I can not get, 3 to 1, with the man with a gun. Between me and Jim, we have boned the tails of thousands of critters; but never more did we take than was necessary for the day thereof.

One morning in the late fall, the sky to the East, over the rise of the Rockies, was overcast with catspaws, which, with other signs, told of the approach of a storm.

"Let's slick up camp and get on the spurs for home," said I.

So Jim struck out to bunch our ponies, which were grazing down by the bottoms of the lower Missoula, 20 miles away. I took over a low divide to a place we called the Crotch. It was the turning point of our line of traps and about 15 miles from our home shanty. I calculated to make the swing before noon the next day; so I went along not minding any sign until I was half way to the Crotch. There I set out a few snares in a hazel thicket to catch my dinner, and lay by. I fell asleep, but soon awakened with a start. The wind had risen and the air was smoky from a blaze somewhere on the mountain. I struck out, forgetting my snares, until near the Crotch.

Had I had a gun I could have killed slathers of game; elk and deer by the score had crossed my trail, and the snarl and grunt of panthers and bears were heard in the short hills about

On nearing the Crotch I looked for fresh sign and was not long in finding it. There, on the point, below our temporary camp, was the crown of a Qualptry moccasin. I commenced some tall sneaking, having heard before of the whelps, who were a small band of the lower Flatheads. The sign bore North and was about 2 days old; and our camp was picked as clean as a whistle.

Night fell, with a lurid glare from the fire on the mountain. I sat down in the old camp and chewed on a good big chunk of grin-and-bear-it. I was madder than a wet cat and as hungry as a bear. I crawled to the bluff, determined to stuff my grub box with something or other. I struck elk sign. One of the tracks was as large as that of a 3 year old steer and by the glint of the moon I could see that the elk's frog was flat and his hoof worn down, so I knew he was an old bull, perhaps the leader of a band. Presently I came on a band of about 300 elks, among them this old bull. They were all lying down like cattle in a barn yard.

I swung to the windward of the band and came out abreast of the old bull. In less time than it takes to tell I was astride of him. He jumped up with a snort and before I could wink, the whole band was milling about us. I saw my mistake, but it was too late. I dug my knife into his short ribs and it broke off at the heel. The bull turned and we were off, with the whole band cavorting behind us. I was scared, but I took a good hold of his ears to get protection from his horns as we flew through thickets of bull pine and hazel. Toward morning I noticed the bull was a little fagged. Just then we came out of the timber on to a prairie and in shifting my hold I dropped my coonskin cap, which caused the band of 700 elk behind us to split. I took advantage of that and slid off on the nigh side among a lot of buck brush. I lay there kind of numb like, I do not know how long. At last I recognized the crack of Jim's rifle. Not more than 200 yards away stood our shanty with Jim coming up from the meadow leading our pack stock.

We met at the door and Jim, seeing the trouble in my phiz, led me without a word to the jug and the beanpot.

Metol-quinol developer in 2 solutions, to keep a long time and for short exposures is made as follows:

Metol .....	50 grains, 10 grams
Quinol .....	40 grains, 8 grams
Potassium metabisulphite,	$\frac{1}{2}$ ounce, 50 grams

Distilled water,

To 10 ounces, 1,000 cubic centimeters  
Sodium carbonate ..... 2 ounces, 100 grams  
Distilled water,

To 10 ounces, 1,000 cubic centimeters

For use, mix in equal parts. Bromide should not be used for short exposures. If required, add  $\frac{1}{2}$  grain to every ounce of the mixed developer.—The Photo-American.

# BUILDING FOR OLD AGE

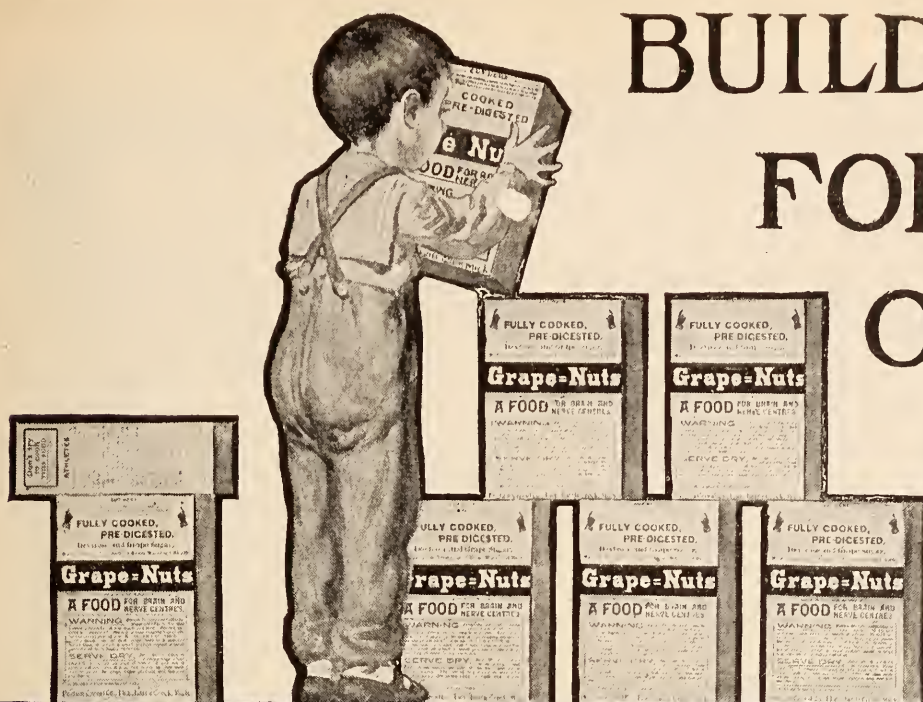

Children particularly need food containing the elements that make the soft gray matter in nerve cells and brain.

When brain and nerves are right the life forces select the bone and teeth making parts and the muscle making elements and day by day build up a perfect and powerful structure.

So people should let the youngsters have Grape-Nuts and cream every day. They like it and you can be absolutely certain you are feeding them wisely and scientifically.

A few weeks will prove it to you in the appearance and activity of the child.

Do your duty by the children.

*There's a reason.*

## A NARROW ESCAPE.

It was in November, 1902, and Doc and I, with 2 or 3 others, had gone to the woods for our annual deer hunt. Camp was made and just after lunch we all set out on individual exploring trips. We had no understanding with one another as to which way we should go or what time we should get back to camp.

I wandered along aimlessly and do not remember much about the country passed through, but I had not gone far before I found myself in the middle of a large plowed field, and when a big doe jumped up out of the furrows just as a jack rabbit would do, I threw my gun to my shoulder and down she came.

I may have been a little surprised at this, because the gun had not gone off, and I knew enough about deer to be aware that they do not usually drop until after they are shot, but I dressed her just the same. Doc arrived in time to help me hang her up, which we did with some difficulty by placing an old burnt pole in the limbs of a small cherry tree. This cherry tree seemed entirely too small to hold the doe, and kept bending over and letting her down, but we finally got it to stay and started on. I don't know where Doc went; in fact, I do not remember anything more about him that day.

I entered the woods again. The timber was not large, but the underbrush was thick, and I had considerable difficulty in getting through it until I struck an old trail that soon led me to the brink of a deep canyon about 100 yards wide. On both sides were perpendicular rocks at least 150 feet high. Although I had hunted in that territory several seasons, I had never heard of that canyon, and the whole country seemed entirely strange to me.

I looked off to the East, where I knew there should be a tall, splintered pine with one long limb running out near the top. That old broken pine was one of my landmarks, and could be seen a long distance from almost any direction; but it was not there. For the time, at least, I was lost, but I had had one or 2 experiences of that kind before, and had always managed to find my way out, so this did not bother me much. I was just thinking what a good story I should have to tell when I got back to camp when I saw a large buck step quietly out of a thicket into a little clearing less than 30 yards away. He was a fine looking fellow, with magnificent antlers, and I noticed at the first glance one peculiar feature about him. His tail looked exactly like that of my setter dog, and stood out straight behind with fine curly hair hanging down 4 or 5 inches.

The buck stood broadside to me and raised his head to crop a tall weed just in front of him. I took careful aim at his neck and fired. He paid no attention whatever, and I fired again and then again with the same result. I do not know what I thought was the matter but I soon com-

menced shooting at the largest part of the deer and trying to hit him just back of the forward shoulder or in fact any where; but the old fellow still kept chewing that weed. After I had shot twice as many times as the magazine ever held cartridges I stopped to wipe my eyes and try to quiet my nerves. About that time the old buck located me and without a moment's hesitation lowered his head and charged.

I remember thinking I must make my next shot tell and held my fire until he had covered about half the distance between us. Then making sure that the little ivory bead pointed exactly between his eyes I pulled the trigger. The hammer did not fall, neither did the gun go off. I pulled hard on the trigger again, but it would not move a particle. The thought struck me that in the excitement I had got hold of the guard instead of the trigger, but no, my finger was in the right place. I threw the lever forward and back and pulled again as hard as I could, but the trigger would not move a hair and the gun failed to do execution. There I was, between the brink of the canyon with a drop of at least 150 feet to the rocks below, and a charging buck with every hair on his body turned toward his head. For some reason I turned and ran. Although ordinarily a fair sprinter, my nerve was all gone and I could hardly get one foot ahead of the other. I tried to cry out but there was only a hoarse dry rattle in my throat. Then I felt the sharp horns of the buck strike me between the shoulders, my head flew back with a snap, a cold shiver went down my spine, I was falling from the brink of the precipice and all was over. Probably about a second later I opened my eyes and at first could not realize where I was. There were no woods, no canyon, no gun, no deer. Only a man still in bed who had been dreaming.

J. A. R., St. Charles, Minn.

---



---

 TONING BROMIDE PRINTS WITH PLATINUM.

Recent experiments show that bromide prints can be satisfactorily toned by either platinum bichloride or potassium chloroplatinite. The formula advised is as follows:

Potassium chloroplatinite.....	1 grain
Mercuric chloride.....	1 grain
Citric acid.....	.9 grains
Water .....	1 ounce

The speed of the toning action with this formula is about the same as that of an ordinary gold or platinum bath with p. o. p. The tint produced is a warm sepia, and may be varied slightly by increasing the mercury, when the tone will be somewhat lighter. Platinum bichloride may be substituted for the chloroplatinite, but other salts, such as the ammonium chloroplatinite, do not work satisfactorily.—Exchange.



# THREE SPLENDID BOOKS

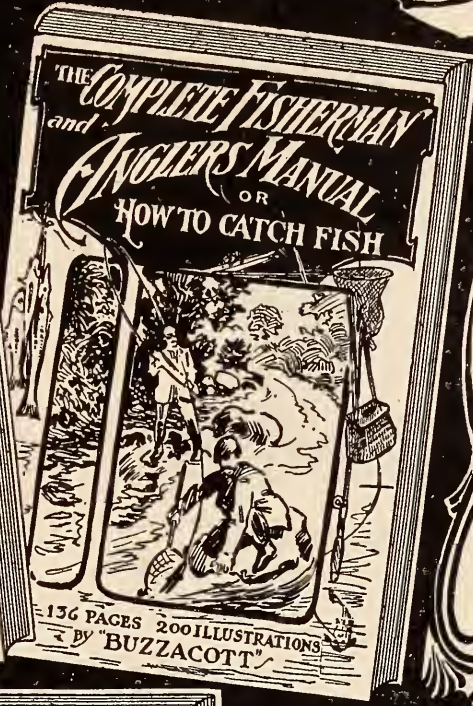
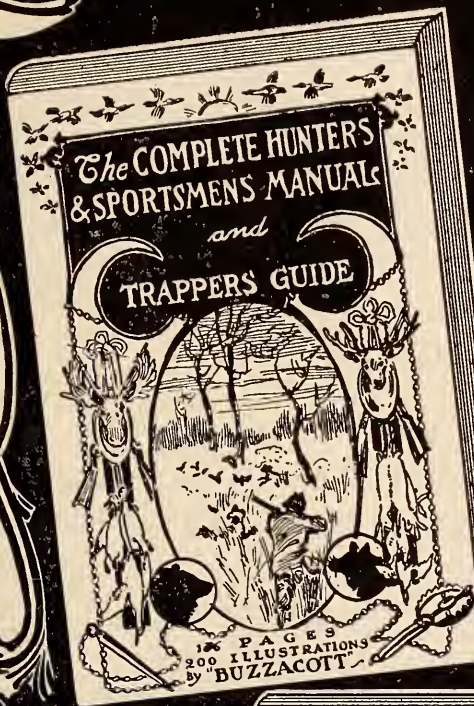

**EACH BOOK**

136 PAGES  
200 ILLUSTRATIONS

"Fairly Bristles"  
with facts and information from cover to cover

"GLITTERS"  
WITH PICTURES

THOUSANDS OF  
FACTS, HINTS,  
POINTERS  
WRINKLES  
and KINKS

YOU OUGHT  
TO KNOW

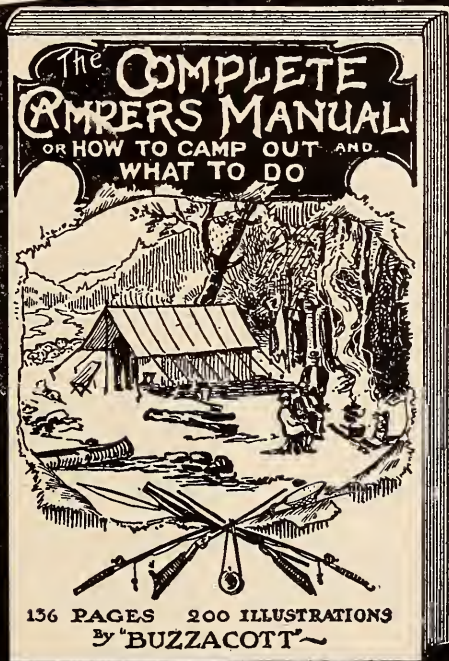

**SEND 10c**

COIN OR STAMPS  
FOR EITHER BOOK  
OR 30c COIN FOR  
THE THREE BOOKS  
**408 PAGES**

They are better than  
most books sold at \$2  
to \$3 a copy. Your  
money back if you  
ain't more than pleased.

Address

**BUZZACOTT**

The Complete Camp  
Outfitters Dept. A

RACINE JCT., WIS.  
or CHICAGO, ILL.

Don't be like the man  
riding backwards on a street car, never sees anything  
until HE'S PAST IT. "SEND FOR ONE NOW."

FIRST EDITION OF 100,000 COPIES NEARLY EXHAUSTED

# EYE DISEASES

CURED WITHOUT SURGERY

Is the Title of a Book by Dr. Oren Oneal, which will be sent Free. It describes and illustrates Various Eye Diseases and tells how they can be Cured at Home, Quickly and at Small Expense



This noted Chicago Oculist, known as America's most expert specialist, announces the twenty-fourth edition of his book—a handsome illustrated volume—and generously offers to send the same to anyone who is interested enough to ask for it. It contains much valuable information about the eye and the cure of Cataracts, Optic Nerve diseases and all other causes of blindness. The book is certainly a valuable aid to all who are in any way afflicted with their eyes, as it tells them how they can cure themselves at their own homes quickly and at small expense. No leaving home, family and friends, no hospital or sanitarium, no confinement in dark rooms nor inconvenience in any way. The book contains testimonials of many who have been cured by Dr. Oneal's Dissolvent Method. Some of them had been totally blind for years. They had been given up as incurable by others; they had been butchered and blinded by the surgeon's knife, yet Dr. Oneal cured them by his simple, sure and scientific treatment. No one can successfully dispute these statements. The proof is too abundant. Dr. Oneal can refer you to cured cases in every state and territory, and in foreign countries. You can go to see them or write to them.

Among Dr. Oneal's recent and notable cures are those of Mrs. C. H. Sweetland, Hamburg, Ia., paresis of the optic nerve; Mrs. Herman Burdick, Richland Center, Wis., hemorrhage of retina; Miss Johanna Schmidt, 392 17th St., Milwaukee, cataracts; A. J. Staley, Hynes, Cal., cataracts of 20 years; Miss J. M. Rumsey, Norwalk, Ohio, cataracts; Mrs. Amelia P. Rifle, 78 Niagara St., Buffalo, N. Y., cataract. These people administered Dr. Oneal's treatment at home and cured themselves. Cross-eyes are straightened by Dr. Oneal without knife or pain. John Turner, Leroy, Ind., cured.

If you will write Dr. Oneal describing your case the best you can, he will send you this book and advise you free of charge. A postal card will get the book. Address

**OREN ONEAL, M. D.**

Suite 839,

52 Dearborn St., Chicago

# TALES OF ADVENTURE.

Rare Hunting and Fishing Stories.

I have a few sets of Volume 3 of RECREATION, July to December, inclusive, 1895. These are handsomely bound in cloth, with leather backs and corners.

Here are the titles of a few of the choice stories in the book.

**Woodcock on the Islands.**

Illustrated. F. W. G. Johnson

**The Gordon Setter.**

Illustrated. Dr. J. Whitaker

**Salmon Fishing in Labrador.**

Illustrated. Col. Charles E. Fuller

**Coursing with the Greyhound**

Illustrated. L. F. Bartels

**A Bald-Faced Grizzly in Camp.**

Illustrated. M. W. Miner

**Where Leaps the Ouananiche.**

(Poem.) Dr. E. L. Tiffany

**Fly Fishing** ..... Dr. M. G. Ellzey

**A Half Hour With the Quail.**

Dr. E. P. Kremer (Juvenis)

**A Deer Drive with Spokane Indians.**

Illustrated. Lieut. W. R. Abercrombie

**An Indian Horse Race.**

Maj. F. M. Bernard

**The Old Kentucky Rifle.** (Poem.)

Illustrated. Capt. J. W. Crawford

**A Mystery of the Tetons.**

Illustrated. Ed. H. Trafton

**Pheasant Shooting.**

Illustrated. Thomas G. Farrell

**Sitting Bull's Last Medicine.**

Illustrated. Margaret Gray Brooks

**Crossing the Plains 30 Years Ago.**

Illustrated. Gen. John Gibbon, U. S. A.

**A Mountain Lion Hunt by Night.**

Illustrated. Robert Meade Smith, M.D.

**Trouting on Clark's Fork.**

Illustrated. Gen. F. W. Benteen, U. S. A.

**Ducking off Machipongo.**

Illustrated. W. J. Bogert

**A Youthful Guide and a Prize Bighorn.**

Illustrated. Hon. I. N. Hibbs

**A Wild Goose Chase.**

Illustrated. A. E. McKenzie

**A Tempestuous Cruise.**

Illustrated. Commodore Chas. Pryer

**Hans the Wolf Hunter.**

(Poem.) Illustrated. S. N. McAdoo

**How Some Women Went Shooting.**

Illustrated. Julia C. Welles

These books will be sold at \$2.00 each, and when the present supply is exhausted there will never be any more. If you want a copy remit at once. Address,

**RECREATION,** 23 W. 24th St.,  
New York City



**H. J. TILLOTSON, M. D.**  
**The Master Specialist of Chicago, who Cures Varicocele,**  
**Hydrocele, and treats patients personally.**  
**Established 1880.**  
 (COPYRIGHTED)

# Varicocele Hydrocele

**Cured to Stay Cured in 5 Days.**  
**No Cutting or Pain. Guaranteed**  
**Cure or Money Refunded.**

**VARICOCELE,** Under my treatment this insidious disease rapidly disappears. Pain ceases almost instantly. The stagnant blood is driven from the dilated vein and all soreness and swelling subsides. Every indication of Varicocele vanishes and in its stead comes the pleasure of perfect health. Many ailments are reflex, originating from other diseases. For instance, innumerable blood and nervous diseases result from poisonous taints in the system. Varicocele and Hydrocele, if neglected will undermine physical strength, depress the mental faculties, derange the nervous system, and ultimately produce complicated results. In treating diseases of men I always cure the effect as well as the cause. I desire that every person afflicted with these or allied diseases write me so I can explain my method of cure, which is safe and permanent. My consultation will cost you nothing, and my charges for a perfect cure will be reasonable and not more than you will be willing to pay for the benefits conferred.

**Certainty of Cure** is what you want. I give a legal guaranty to cure or refund your money. What I have done for others I can do for you. I can cure you at home

**Correspondence Confidential.** One personal visit at my office is preferred, but if it is impossible for you to call, write me your condition fully, and you will receive in plain envelope a scientific and honest opinion of your case. Free of charge. **My home treatment is successful.** My books and lectures mailed free upon application.

**H. J. TILLOTSON, M. D., 140 Tillotson Bldg, 84 Dearborn St., CHICAGO**

## TO FIND THE SPEED OF A LENS.

The first thing to be done is to determine its focal strength. To do this fasten a foot rule or other scale to a wall, and adjust the camera carefully in position till the image on the screen is at once in sharp focus and of precisely the same size as the original. Of course, it is not necessary that the whole of the rule should appear on the screen, but the portion which is seen must be exactly of the same size. One-fourth of the distance from the rule to the screen is the focus of the lens. Having determined this point, focus the lens on a distant object, fit a piece of cardboard close against the inside of the focusing screen, and pierce a hole in the center of it with a pin, or, better still, with a piece of fine wire which has been made red hot. Carry the camera into a darkened room without shifting the position of the lens and place a lighted candle behind the pinhole. Hold a piece of ground glass against the hood of the lens, and a disc of light will be seen on it. The diameter of the disc is the aperture at which the lens works. To find its focal value it must be divided into the focus of the lens. For example, if the diameter of the disc is  $2\frac{1}{2}$  inches and the focus of the lens is 10 inches, the lens is working at  $f\ 4$ .—Exchange.

Our department for the protection of game and fish did good work again last month. According to the official report of the State game warden, Mr. Henry Overbeck, 52 illegal hunters and fishermen were arrested. The receipts for confiscated articles amounted to \$351.80 and the fines to \$530. The largest seizure was a shipment of 1,078 pounds of black bass, shipped in closed season from Green Bay to Chicago. It was seized by warden Vollbrecht, of Milwaukee. The first were sold for \$153.30. The most seizures in the month of April were made by warden Valentine Raeth, of Milwaukee. They comprised gill nets, hoop nets, fyke nets, set lines, decoys and 6 illegal shipments of fish. Mr. Raeth also arrested, with warden Vollbrecht, a man in Dodge county for fishing with nets. The offender was fined \$25 and costs. The 18th of April Raeth arrested 2 hunters from Illinois for shooting ducks in Kenosha county in closed season. They were fined \$20 each. George Redmond and A. Johnston, wardens, caused the arrest of 15 illegal fishermen in Marathon county, and 12 of the fish hogs were convicted.

Aug. Plambec'.

Milwaukee, Wis.

Out of 40 periodicals we subscribe for, RECREATION is read more extensively than any other 2.

Ariel Club, Lewiston, Me.

IN ANSWERING ADS PLEASE MENTION RECREATION.

A Pair of  
HIGH GRADE  
**Hunting Boots**



LISTED AT \$10

For 6 Yearly Subscriptions to

**RECREATION**

**TRY THEM**

For particulars Address

**RECREATION** 23 West 24th Street  
NEW YORK CITY

# SHREDDED <sup>WHOLE</sup> WHEAT BISCUIT

**Makes Strong,  
Healthy Children**

**BE ALERT** where the welfare of your children is concerned. If you want them to become vigorously manly men and strong womanly women safeguard their health with the Natural Food—*Shredded Whole Wheat Biscuit*—the only natural porous (digestible) food made from wheat. In this natural builder is contained the exact food counterpart of every element of the body and in the same proportion—that is why it is called the Natural Food.

*Shredded Whole Wheat Biscuit* is crisp and compels thorough mastication which strengthens the teeth and insures perfect digestion.

**Dr. Francis H. Plummer, Chelsea, Mass., says:**

"Your product has been in constant use in my family for a long time. It is a perfect food from a physiological standpoint and aside from that, it has the additional merit of being an appetizing addition to one's menu. I can especially commend it as a very desirable addition to the dietary of any family."

**Sold by All Grocers.**

Send for the Vital Question Cook Book illustrated in colors **FREE**. It tells how to prepare *Shredded Whole Wheat Biscuit* in over 250 ways.

**Address The Natural Food Company, Niagara Falls, N. Y.**

## MAKING SOLUTIONS.

Procure a large jar with a wide mouth. If there be a cork or a cover so much the better. Make a small muslin bag about 1-3 the length of the jar to be used, and the same circumference as the neck thereof, and put a drawstring in the top of bag of sufficient length to allow the neck of bag to extend the width of the cover or cork. The bag must be nearly filled with hypo, the cork or lid put on top inside the bag and the string drawn up and tied. Next almost fill the jar with water and allow the bag to hang therein, supported, of course, by the lid. The water will dissolve the hypo, and the solution, being heavy, will sink, causing the water to rise and take up more of the chemical. This will go on until a saturated solution is formed, or until all the hypo is dissolved. To make a saturated solution of hypo, take water 10 ounces, hypo 4 ounces, or in about that proportion. This should be diluted with equal bulk of water for fixing plates, and twice the bulk for prints.—Exchange.

Silver Creek, N. Y.

Century Camera Co.:

Received camera and thank you for your promptness. It is a fine instrument, and I am well pleased with it. It well deserves the name of the Century Grand.

Perry Trask,

## ATTENTION BASS FISHERMEN !!

**What It Is.** A Bass lure combining all the good points of the old fashioned spinner baits with the construction of the modern wooden minnow.

**What It Will Do.** This lure is constructed in a new manner with a new feature and will catch more bass than any other artificial lure.

**How To Get It.** Send one dollar to Recreation for a year's subscription to be credited to my account and I will mail you one postpaid. **W. B. HAYNES, 274 Park Street, Akron, Ohio.**

## IN YOUR OUT DOOR LIFE

YOU WILL NEED A

## Duplex Fork



for handling hot potatoes, ears of corn, boiled eggs, and other hot food, and you will find it indispensable for use with pickles, fish and meats that an ordinary fork will break. The forks are always open and ready for use, and with a slight pressure on the handle anything can be easily taken hold of without fear of breaking.

**Postpaid, 25 Cents**

**E. A. LYFORD, 3090 Gilbert Ave., Cincinnati, O.**  
Mention RECREATION.

**MENNEN'S BORATED TALCUM TOILET POWDER**



A Positive Relief For  
**PRICKLY HEAT, CHAFING, and SUNBURN,** AND ALL AFFLICTIONS OF THE SKIN.

"A little higher in price, perhaps, than worthless substitutes, but a reason for it." Removes all odor of perspiration. Delightful after Shaving. Sold everywhere, or mailed on receipt of 25c. Get Mennen's (the original). Sample Free.

GERHARD MENNEN CO., Newark, N. J.

**Reduce Your Fat**



but don't ruin your stomach with a lot of useless drugs and patent medicines. Send to Prof. F. J. Kellogg 835 Kellogg Building, Battle Creek, Michigan, for a free trial package of a treatment that will reduce your weight to normal without diet or drugs. The treatment is perfectly safe, natural and scientific. It takes off the big stomach, gives the heart freedom, enables the lungs to expand naturally, and you will feel a hundred times better the first day you try this wonderful home treatment.

A cement to withstand water and dilute mineral acids can be made as follows:

- Burgundy pitch.....6 ounces
- Guttapercha .....1 ounce
- Pumice powder.....3 ounces

Carefully melt the guttapercha, add the pumice powder, and finally the pitch. Let the mixture digest until homogeneous, and use while still hot.—Exchange.

When I order a Bristol rod, I know what I am about, as I have used one 3 years; and on it I have used the automatic reel. They are all that is claimed for them and more. The manufacturers of them are wise to advertise in RECREATION.  
S. L. Warner, Lanesville, Conn.

I did not have much trouble in getting 35 subscribers. Everyone to whom I showed a copy of RECREATION was pleased, and did not hesitate to subscribe.  
Henry A. Blish, Boston, Mass.

**ARNICA Tooth Soap**  
the International Dentifrice



Beautifies the teeth, hardens the gums, sweetens the breath. Preserves as well as beautifies the teeth. Comes in neat, handy metal boxes. No powder to scatter, no liquid to spill or to stain garments.

25 Cents  
At all Druggists.  
C. H. STRONG & CO., Proprietors,  
Chicago, U. S. A.

A DEALER'S EXPERIENCE.

I have noticed the general complaint against the Marlin rifle. My experience with that rifle and its manufacturers was that I could get as much satisfaction out of the company as I could out of their balky guns. My finish with the Marlin came about this way. Eight years ago I sold one of their 32 rim or center fire rifles to a customer who was going on a vacation and wanted the gun to take with him. The first week he had it the extractor hook broke. I sent it to the Marlin people stating that it was from a rifle I had just sold and that the customer was waiting for a new hook. I asked them to send one by return mail, and said I would remit whatever the charges might be. I waited one week and, not hearing from them, wrote again. After 4 or 5 days I got a reply stating the extractor would cost 23 cents, and would be sent on receipt of the money. I wrote them to return the broken piece and I would make a new one. They said they were sorry but they had thrown away the broken piece; under the circumstances they would send me an extractor. They did so, and in return I sent them 23 cents and a promise never to sell another Marlin rifle. That promise I have kept. I had sold before that 5 or 6 others and had had trouble with nearly every one of them.

A. B. Elliott, Chenango Forks, N. Y.

THE CAMERA HUNTER.

(Editorial in St. Paul Pioneer-Press.)

With all hunting with guns prohibited, except in the case of beasts of prey, like the wolf, the mountain lion and the wildcat, deer and game birds of all sorts would so multiply that the larder could be far more abundantly supplied through other agencies than sportsmen; and venison and prairie chickens would find their way to many more tables than at present. To the temperament which delights in mere killing, and which finds no appreciable enjoyment in hunting unaccompanied by bloodshed, the camera as a substitute for the gun would of course be unwelcome; but this temperament is not that of the true sportsman, and is fortunately becoming rare. The true sportsman is he who goes for game because he loves the life of woodland, lake and river; loves to trace the furred and feathered creatures to their haunts, to observe their ways, and to feel the thrill of the supreme moment when gun or camera shall do its work. The work of the camera is so much more enduring, affords so much after-enjoyment, not alone to the sportsman, but to his friends, and perhaps to the public, if it shall be given to the press, that it would seem infinitely preferable to the other. No game laws limit the season or the number of shots the camera hunter may make; nor is his a merely selfish amusement, as is in most cases that of the man with the gun. The generous hunter who now divides his game among a few friends may with the products of a camera make his whole circle happy.

FREE BOOK, WEAK MEN



My illustrated nature book on losses, varicocele, impotency, lame back, free sealed, by mail. Much valuable advice and describes the new DR. SANDEN HERCULEAN ELECTRIC BELT. Worn nights. No drugs. Currents soothing. Used by women also for rheumatic pains, etc. 5,000 cures 1922. Established 30 years. Advice free.

DR. G. B. SANDEN,  
1155 Broadway, N. Y.

# THE Keeley Cure

**Alcohol,  
Opium,  
Tobacco  
Using**

Produce each a disease having definite pathology. The disease yields easily to the Treatment as administered at the following Keeley Institutes:

ALWAYS ADDRESS THE INSTITUTE NEAREST TO YOU.

Birmingham, Ala.	Crab Orchard, Ky.	Omaha, Neb.	Providence, R. I.
Hot Springs, Ark.	New Orleans, La.,	Cor. Leavenworth	Columbia, S. C.
Los Angeles, Cal.	1628-38 Felicity St.	and 19th Streets	Dallas, Tex.,
San Francisco, Cal.,	Portland, Me.	Columbus, O.	Bellevue Place.
1170 Market St.	Lexington, Mass.	Cor. 3rd and	Richmond, Va.
West Haven, Conn.	Grand Rapids, Mich.	Dennison Aves.	Seattle, Wash.
Washington, D. C.,	St. Louis, Mo.	Portland, Ore.	Huntington, W. Va.
211 N. Capitol St.	Boulder, Hot Springs,	Harrisburg, Pa.	Waukesha, Wis.
Augusta, Ga.	Boulder, Mont.	Philadelphia, Pa.,	Toronto, Ont.
Dwight, Ill.	Fargo, N. D.	812 N. Broad St.	Winnipeg, Man.
Charlestown, Ind.	North Conway, N. H.	Pittsburgh, Pa.,	London, Eng.
Marion, Ind.	Buffalo, N. Y.	4246 Fifth Ave.	Cape Town, S. A.
Des Moines, Ia.	White Plains, N. Y.		

Rev. T. DeWitt Talmage's famous lecture, "Evils of Intemperance," mailed on application. LESLIE E. KEELEY, M.D., LL.D.

WHAT THE  
RT. REV. JOHN SHANLEY  
BISHOP OF NORTH DAKOTA, Says:

It is because I know it does save them, because I know it is God's truth that I take the deepest interest in the Keeley Cure, and so long as I live I shall raise my voice in advocating its efficacy.

Rt. Rev. JOHN SHANLEY,  
Bishop of North Dakota.

Details of treatment and proofs of its success sent free on application.



## A KNIT JACKET

A handy and comfortable garment to wear when shooting

**At the trap  
In the field, or  
In the woods.**

For 3 yearly subscriptions to RECREATION I will send you a **Hand Knit Jacket**, made by Geo. H. Webber, Detroit, Mich., and listed at \$4. You can get the 3 subscriptions in 20 minutes.

**Sample copies of RECREATION  
sent on request.**

I am pleased to see that you are taking up your good cause in Canada as well as in the United States, as shown by your roast of Dr. Preiss and Mr. Bidwell on page 442 of JUNE RECREATION. It is a pity these men should not look higher than to butcher squirrels. No real sportsman would kill any animal so harmless and so friendly when given any chance. These men, however, could not have been anything else than what RECREATION calls them, for they used shot guns, as shown by the shells in their belts. It is a pity that the dog, which can not see both sides of the question, should not belong to some sportsman and not be associated and photographed with such men as Preiss and Bidwell.

A. F. R., Montreal, Can.

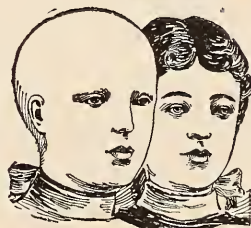

## FREE HAIR GROWER.

MISS EMMA EMOND,  
of St. Sauveur, Quebec, Can.,  
before and after using  
Foso Treatment.

A trial package of a new and wonderful remedy mailed free to convince people it actually grows hair, stops hair falling out, removes dandruff and quickly restores luxuriant growth to shining scalps, eyebrows and eyelashes. Send your name and address to the Altenheim Medical Dispensary, 114 Foso Bldg., Cincinnati, Ohio, for a free trial package, enclosing a 2c. stamp to cover postage. Write to-day.

# Going Fishing?

Well fixed for rods? If not,  
send me 5 yearly subscriptions to

## **RECREATION**

and get a Bristol Steel Rod—  
any one listing at \$6.00 or less.

---

---

Everybody knows what a Bristol  
Steel Rod is. It is equal in  
strength, durability, suppleness,  
and all the other good qualities to a  
split bamboo rod costing \$20.

This is a great opportunity  
and holds good only **SIXTY**  
days.

Sample Copies of Recreation  
for use in canvassing fur-  
nished on application.





**ROOT'S UNDERWEAR**

**For Men, Ladies and Children**

Root's Camelhair goods are genuine camelhair. Other makes are only "camelhair" in name. Root's Natural Wool goods are made of the combined wools of white and black sheep or lambs, and contain no dyed material. Root's White Wool and Merino goods, sterling value.

Sold by principal dealers in New York and all large cities.  
If not by yours, write to

**Root's Underwear, 1 Greene St., New York**

A cleansing fluid for grease spots, which may be found useful in photographic work-rooms and studios, can be made as under:

- Oil of turpentine.....4 ounces
- Ammonia .....4 ounces
- Spirit of soap (methylated).....2 ounces
- Acetic ether.....2 ounces
- Alcohol (methylated).....2 ounces

After mixing, it is ready for use. When stood aside, the compound will require shaking before application.—Exchange.

A friend and I went hunting recently. I used U. M. C. ammunition and every cartridge exploded when the hammer fell. My friend used Peters shells and although he tried about 25 only 2 went off at the first pull; some would not explode at all. That shows what fine ammunition the Peters Cartridge Co. makes.

Alvan Smith, Stafford Springs, Conn.

RECREATION is well worth the money.

C. R. Harris, Portland, Me.

No. 58

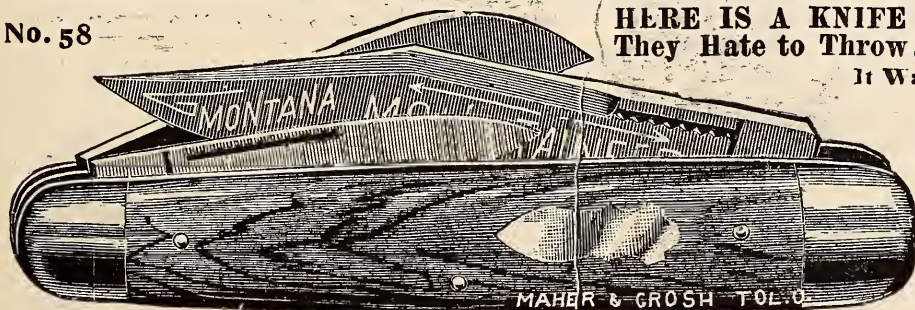

**HERE IS A KNIFE Men Love So Much They Hate to Throw an Old Handle Away**

**It Was Teddy's Camp Knife!**

No. 58. Cut is exact size; ebony handle. 3 blades, German Silver ends. The long blade is for rough or fine work; the medium blade is as thin as a razor. Price, postpaid, \$1, 6 for \$5.

The lower cut is "Chauncey Depew's pet," has three blades (one is a file). Handle is choicest selected pearl; German silver back and ends. Price in chamois case, \$1.50 postpaid. Same knife, 2 blade, \$1; plainer finish, 3 blade, same quality, \$1; smaller 2 blade, for lady, 75 cents.

Illustrated 80-page List free, and "How to Use a Razor."

**Maher & Grosh Co.**  
744 STREET, TOLEDO, O.



# WEBBER'S HAND-KNIT JACKETS

(Look for Name in Collar Band)



WEBBER'S JACKET

**HAND-KNIT HUNTING JACKET. Medium, Heavyweight, each \$4.**

**HAND-KNIT ALASKA JACKET. Made with strap across throat, lined pockets and extra heavy, each \$5.**

**HAND-KNIT SWEATER, NO. 851. Made with strap across throat, lined pockets and extra heavy, opens from neck to pockets and double breasted, each \$5.**



WEBBER'S NO. 851

Made in any Color. Suggest Dead Grass, Oxford Grey, and Scarlet for Deer Hunting. Sent express-charges prepaid, on receipt of price. **Ask your Dealer for Webber's Jackets**

**GEO. F. WEBBER, Manufacturer,**

**Station A., DETROIT, MICH.**

## REMARKABLE OFFERS.

To every person who will send RECREATION \$1 for 1 year's subscription to be placed to my credit I will give as a premium a choice of a Nickel Plated Match Safe, or a Gilt Metal Match Safe, or a Hard Rubber Water Proof Match Safe, each listed at 40 cents; or a Nickel Dog Whistle and pocket drinking cup, listed at 50 cents; or a Nail Clipper, with file and Nail Clipper attached, listed at 40 cents; or a 25 yard Single Action Reel, listed at 40 cents; or a 25 yard Water Proof Silk Line, listed at 50 cents.

For 2 subscriptions a Hunting Knife, Stag Handle, blade 5½ inches long, listed at \$1.

For 3 subscriptions a Patent Double Minnow Bucket, listed at \$2; or a 60 yard Multiplying Reel, listed at \$2; or a 3-piece Bamboo Rod, 7 or 9 feet long, listed at \$2; or a Heavy Silk Watch Fob, listed at \$1.50.

For 5 subscriptions a fancy striped Hammock, listed at \$3; or a Hunting Knife, listed at \$3; or a Tackle Box, listed at \$3.

For 9 subscriptions a field glass listed at \$6.

Only a limited number of subscriptions can be accepted on these offers.

E. W. Jacobs, Coshocton, Ohio.

## A PICTURE FOR SPORTSMEN.

The Chicago and Northwestern Railway has just received from the lithographer a color reproduction of a handsome specimen of speckled brook trout, which is the object of much favorable comment by sportsmen who have seen the work. The original painting from which this has been reproduced is by the well known artist, W. L. Wells. Copy of the lithograph can be had by addressing W. B. Kniskern, P. T. M., Chicago, Ill.

The telescope put on my Winchester rifle by the Malcolm Telescope Co. was a great help to me during my vacation trip to the Canadian woods, enabling me to determine at a distance the nature of indistinct objects. I am well satisfied with it.

H. J. Howe, Syracuse, N. Y.

**For Sale:**—I have a lot of choice elk pictures taken last winter that I should be pleased to send to RECREATION readers at \$1.50 a dozen for 5 x 7, or \$2.50 a dozen for 6-1½ x 8-1½, unmounted.

S. N. Leek, Jackson, Wy.

**For Sale:**—A pair of live Eagles.  
E. B. Schrage, Pontiac, Mich.

## The Reason the LUTHER HAND-MADE GLOVE will not rip



Machine sewing cuts itself



Hand sewing cannot.



## A Practical Hunting and Driving Glove

Made for practical, comfortable, durability. No Oil. No Odor. No Animal Glue. Practically seamless. Cannot Rip. Unaffected by moisture of any kind. If soiled, may be washed with soap and hot water, without injury. The Luther Fastener is adjustable, fits any wrist and cannot get out of order. Illustrated booklet, samples and self measurement rule on application.

If you prefer to buy through your dealer send us his name  
**No. 308 Driving Glove** postpaid anywhere **\$1.50**, made to measure **\$2.50**,  
**No. 320 Gauntlet**, " " " " **3**

**J. P. LUTHER GLOVE CO., 536 Pearl St., Berlin, Wis.**

# Jaeger

## IN FALL

### Is a Boon for All



HIS unique underwear is no fad—no experiment.

The highest medical authorities attest its worth.

A quarter-century's success proves it.

Made of the finest Australian wool, and easily outlasts the best in other brands. Is therefore the best economizer, inasmuch as it saves both health and money.

---

ILLUSTRATED CATALOGUE FREE

---

## Dr. Jaeger's S. W. S. Co's Own Stores

NEW YORK: 305 Fifth Ave., 157 Broadway

BROOKLYN: 504 Fulton Street

BOSTON: 230-232 Boylston Street

PHILADELPHIA: 1510 Chestnut Street

CHICAGO: 82 State Street

---

AGENTS IN ALL PRINCIPAL CITIES

## SOME RARE OPPORTUNITIES

These goods are all new, and will be shipped direct from factory. Prices named are those at which manufacturers and dealers usually sell. Here is a good chance to get

A Book, a Gun, a Camera  
A Sleeping Bag, a Fishing Rod  
A Reel, a Tent, } FREE OF COST

Subscriptions need not all be sent at once. They may be sent in installments as taken and credit will be given on account. When the required number is obtained the premium earned will be shipped.

### TO ANY PERSON SENDING ME

TWO yearly subscriptions to RECREATION at \$1 each, I will send a copy of *Hunting in the Great West*, cloth; or a Zar Camera, listed at \$1; or an Ingersoll Watch or Cyclometer, listed at \$1; or a Recreation Waterproof Match Box, made by W. L. Marble and listed at \$1; or a Shakespeare Revolution Bait listed at 75 cents; or a Laughlin Fountain Pen; or a dozen Trout Flies, assorted, listed at \$1; or a pair of Attachable Eyeglass Temples, gold-plated, made by Gall & Lembke; or one Rifle Wick Plug, made by Hemm & Woodward, Sidney, Ohio, 30 caliber to 50 caliber, or Shotgun Wick Plug, 20 gauge up to 10 gauge, or a pair of chrome tanned horsehide hunting and driving gloves, listed at \$1.50, made by J. P. Luther Glove Co.

THREE subscriptions at \$1 each, a safety pocket ax, made by W. L. Marble and listed at \$2.50; or a dozen Bass Flies, assorted, listed at \$2; or a pair of Shotgun Wick Plugs made by Hemm & Woodward, Sidney, Ohio, 20 gauge to 10 gauge; or a Polished Buffalo Horn Gun Rack, made by E. W. Stiles; or a pair of gauntlets, for hunting and driving, ladies' size, listed at \$2.50, made by J. P. Luther Glove Co.,

FOUR subscriptions at \$1 each, an Ideal Hunting Knife, made by W. L. Marble and listed at \$2.50; or a 32 caliber, automatic double action revolver, made by Harrington & Richardson Arms Co.

FIVE subscriptions at \$1 each, a copy of *Cruisings in the Cascades*, cloth; or a set of Nehring's Convertible Ampliscopes, listed at \$5.00; or an Ideal Hunting Knife made by W. L. Marble, and listed at \$3; or a pair of lock lever skates, made by Barney & Berry, listed at \$4.50; or a J C Hand trap made by the Mitchell Mfg. Co., listed at \$4.; or a Bristol Steel Fishing Rod, listed at \$6, or less.

SIX subscriptions at \$1 each, a Hawkeye Refrigerating Basket made by the Burlington Basket Co., or one dozen Eureka golf balls listed at \$4; or a Pocket Poco B 3¼x4¼, made by the Rochester Optical & Camera Co., listed at \$9; or a pair of horsehide hunting boots, made by T. H. Guthrie, Newark, N. J., and listed at \$10.

SEVEN subscriptions at \$1 each, a copy of *The Big Game of North America*, or of *The American Book of the Dog*, cloth, or one set Lakewood golf clubs, 5 in number, listing at \$5;

or a series 11B or 11D Korona Camera, made by the Gundlach Optical Co., listed at \$10.

EIGHT subscriptions at \$1 each. A series 1, 4x5, Korona Camera, made by the Gundlach Optical Co., listed at \$12.

NINE subscriptions at \$1 each, an Acme single shot gun, made by the Davenport Arms Co., and listed at \$8.

TEN subscriptions at \$1 each, a Cut-Glass Salad Bowl, made by Higgins & Seiter, and listed at \$4.50; or a Yawman & Erbe Automatic Reel, listed at \$6 to \$9; or a Waterproof Wall Tent 7 x 7, made by Abercrombie & Fitch, and listed at \$8; or a Rough Rider rifle telescope, made by The Malcolm Rifle Sight Mfg. Co., and listed at \$12; or a Pneumatic Camp Mattress, with pillow listed at \$18; or a 10 ft. special canvas boat, made by the Life Saving Canvas Boat Co., and listed at \$35.

TWELVE subscriptions at \$1 each, a Peabody Carbine valued at \$12; or a Davenport Ejector Gun, listed at \$10., or a Cycle Poco No. 3, 4x5, made by the Rochester Optical and Camera Co., listed at \$15; or an 8 ft. folding canvas boat, made by the Life Saving Canvas Boat Co., listed at \$29.

FIFTEEN subscriptions at \$1 each, a Shakespeare Reel, Silver Plated, listed at \$15; or a set of rabbit plates made by Higgins & Seiter, and listed at \$8, or a Field Glass made by Gall & Lembke; or a Kenwood Sleeping Bag, complete, with canvas cover, listed at \$16; or a Bulls-Eye rifle telescope, made by The Malcolm Rifle Sight Mfg. Co., and listed at \$16;

TWENTY subscriptions at \$1 each, a 14-karat Gold Hunting-case Watch, with Waltham Movement, listed at \$20; or an Elita single shot gun, made by the Davenport Arms Co., and listed at \$18., or an Acme Folding Canvas Boat, No. 1, Grade, A listed at \$27; or a Mullins Duck Boat, listed at \$20; or a Shattuck double hammerless shot gun listed at \$25.

TWENTY-FIVE subscriptions at \$1 each, an 11-foot King Folding Canvas Boat, listed at \$38; or a 4 x 5 Planatic lens, made by the Rochester Lens Co., and listed at \$25; or a Syracuse Grade O, double hammerless Gun, made by the Syracuse Arms Co., and listed at \$31.

THIRTY subscriptions at \$1 each, a Waterproof Tent, 14½ x 17, made by Abercrombie & Fitch, and listed at \$25; or a Field Glass, made by C. P. Goertz.

THIRTY-FIVE subscriptions at \$1 each, a 14-foot King Folding Canvas boat, listed at \$48.

FORTY subscriptions at \$1 each, a Savage .303 Repeating Rifle; or a No. 10 Gun Cabinet, made by the West End Furniture Co., and listed at \$32.

FIFTY subscriptions at \$1 each, a No. 20 Gun Cabinet, made by the West End Furniture Co., and listed at \$38.

TWO HUNDRED subscriptions at \$1 each, a strictly first class upright piano, listed at \$750.

Address, **Recreation** 23 West 24th St. New York

### THAT PETERS SHELL

Have read RECREATION since its first appearance and approve the stand it takes for the preservation of game. Am also interested in the deserved hand-down its readers are giving the Peters and the Marlin people.

The repeating feature of the Marlin rifle seems intended as a good joke on those who try to use it.

Regarding Peters' ammunition, I will give an instance to show the poor quality of shell they manufacture, to say nothing of the bum stuff they put in where the powder ought to be. Was out last fall with a 45-90 and some Peters cartridges. I got a shot at a big buck; missed; tried to pump in another shell and couldn't. The buck got tired of waiting and went on down the line, while I sat down to investigate. That Peters shell had blown in 2. The rear half, along with the head of the shell, had been extracted, leaving the remainder in the chamber; so when I threw up the next cartridge of course it would not go in. Have had shells blow off after continued reloading, but never a new factory shell before.

U. M. C. and Winchester ammunition suit me perfectly. In the rifle line I prefer the .303 Savage, having used one since 1895.

S. S. Swenning, Medford, Ore.

### EXTRAORDINARY OFFER.

To any person sending me \$1 for a year's subscription to RECREATION, I will give free one of the following books: 6th and 7th Books of Moses. This is a great book. Every home should have one. Volumes I.-II., bound together in one volume; regular price is \$1. "The Almighty Dollar" is a new book just published, and is worth its weight in gold to any one. Can not be obtained for less than \$1 anywhere.

"Hunter's Guide and Trapper's Companion." This is a book every hunter and trapper should have. Descriptions of these books will be sent for a stamp. This is the greatest offer ever made, and you should not let this pass. Old subscribers may avail of this offer by sending 10 cents extra. Address Henry Nelson, Eckwoll, Minn.

## PIANO Do You Want a Genuine Bargain

Hundreds of Upright Pianos returned from renting to be disposed of at once. They include Steinways, Knabes, Fischers, Sterlings and other well known makes. Many cannot be distinguished from new as a great discount. yet all are offered at a great discount. Uprights as low as \$100. Also beautiful New Uprights at \$125, \$135, \$150 and \$165. A fine instrument at \$290. fully equal to many \$400 pianos. Monthly payments accepted. Freight only about \$5. Write for list and particulars. You make a great saving. Pianos warranted as represented. Illustrated Piano Book Free.

## LYON & HEALY

39 Adams St., CHICAGO.

World's largest music house; sells Everything known in Music

## PRESIDENT SUSPENDERS

For a Gift



In Beautiful Boxes For  
**CHRISTMAS**  
All stores 50c and \$1.00  
or mail prepaid

The C. A. Edgarton Mfg. Co., Box 219, Shirley, Mass.

Arrow root paste is made by mixing equal parts of arrowroot and gelatine, say ½ ounce of each to 5 ounces of water. Soak the gelatine in 3 ounces of water, and dissolve by gentle heat; mix the arrowroot in the remaining 2 ounces, and add to the gelatine when dissolved; allow the mixture to cool, and add ½ ounce of spirit and 3 or 4 drops of carbolic acid. Put in wide mouth bottles or pots for use when needed. —Exchange.

I received the J. C. hand trap and thank you for it. Am much pleased with the way it works.

Walter Flint, Ashtabula, Ohio.

### A GOOD ADVERTISE- MENT must be strong

We teach the profitable profession of Ad-Writing successfully. Why not learn Ad-Writing with the largest and best advertised school?

We also teach by correspondence, Illustrating, Journalism, Proofreading, Bookkeeping, Stenography, Electricity, and Electrical Engineering.

Write for our largely-advertised book, "Struggles With the World," and mention which course interests you.

Correspondence Institute of America, Box 701 Scranton, Pa.



**ADUROL, A NEW DEVELOPER.**

SILAS W. NOURSE, in the Professional Photographer.

Adurol is a bromine substitution product of hydroquinone, and is distinguished from it by a series of valuable properties. In its qualities as a developer it stands midway between hydroquinone and the more rapid developers, metol and paramidophenol, working with the rapidity of the last 2, yet yielding negatives of fine printing qualities without the harshness of hydroquinone negatives.

Adurol developers, whether made up in one or 2 solutions, keep unchanged for considerable time, in tightly stoppered or glass stoppered bottles, and can be varied to suit the operator's needs for detail, density, over or under exposures.

Its use is not limited to dry plates, like pyro, but it can be used for developing bromide papers, also velox and dekkko papers, which have practically revolutionized the printing of to-day.

The formula recommended for dry plates or films is as follows, for a highly concentrated stock solution:

200 cubic centimeters = 7 ounces, distilled water.

150 grammes = 5 ounces, carbonate of potash.

75 grammes = 2½ ounces, sulphite soda, pure crystals.

The mixture becomes warm of itself from the solution of potash. To the somewhat cloudy solution, while still warm, add 15 grammes, ½ ounce, adurol.

Dissolve by shaking. Allow it to stand a short time, and then filter, although it is not absolutely necessary to filter.

For use take ½ ounce stock solution, 5 ounces to 7½ ounces water. For over exposures, add more water. For under exposures, less water. For bromide paper, take one part of stock solution to 30 or 40 parts of water. For velox or dekkko paper, one part to 5 parts of water.

Formula No. 2, for 2 solution developer:

A.—Dissolve in 500 grammes, 16 ounces, water.

Dissolve in 50 grammes, 1 2-3 ounces, sodium sulphite, pure crystal.

And add 10 grammes, 1-3 ounce, adurol.

B.—Dissolve in 500 grammes, 16 ounces, water.

Dissolve in 60 grammes, 2 ounces, carbonate potash.

For use on dry plates, films, velox or dekkko papers, take equal parts of A and B. For more density, add a little more. For bromide paper, dilute equal parts of A and B with 3 to 4 parts of water.

For velox and dekkko papers the following formula has been tried:

10 ounces water.

40 grains adurol.

½ ounce sulphite soda, pure crystal.

400 grains carbonate of soda crystal.

The foregoing works as well as the metol and hydroquinone solution recommended for these papers. In fact, each of the 3 formulæ was tried with and without the bromide of potassium solution, and the whites remained as clear without the bromide as with it.

The test was made with prints from the same negatives, one developed with metol and hydroquinone, one with adurol without bromide, one with adurol with bromide, and the results were as fine with the adurol as with the metol and hydroquinone; but it was found that less bromide was required with the former than with the latter to obtain olive tones, and in preparing the developer it will be found less trouble to weigh out one quantity than a little of 2 developers.

Next in order was to save the 2 solutions, the adurol and the metol hydroquinone, to see which discolored first, so each was put in a glass stoppered bottle and allowed to stand a week. The former is quite clear, while the latter is badly discolored; in fact, of a Van Dyke brown tint, while the adurol is more of a lemon tint. Hence for those who do not care to make up a fresh developer with each batch of velox or dekkko print, adurol will be found the more convenient, it being the better keeper; and when slightly weakened, from developing prints, it will be found adapted to the developing of plates and films.

## DO YOU WANT A LENS?

**If so, why not get a good one?**

**And why not get it free of charge?**

**This is easy.**

Any old box will answer the purpose if it does not leak light; but you must have a fine lens to make a fine picture. You can get

### A Royal Anastigmat Lens, 4x5, Series No. 1

Made by the Rochester Lens Co., Rochester  
New York,

**And listed at \$45,  
For 20 yearly subscriptions  
to RECREATION**

You can get any other lens made by this Company on a basis of one subscription to \$2. of the list price of the lens.

Sample copies of RECREATION for use in soliciting furnished on application.



That's the right definition for the owner of an

# Ostermoor Patent Elastic Felt Mattress \$15.

Comfort is the main point in a mattress.  
Economy is good, of course, but not essential.

## SATISFACTION OF BODY

Each OSTERMOOR mattress is built—not stuffed. Hand-laid sheets of snowy whiteness, each the full size, are carefully compressed into the tick. Softer than hair—never mats or packs as hair does—and never needs remaking and is absolutely vermin-proof. In all respects practically un-wear-out-able, retaining its shape and elasticity under all sorts of conditions and hard usage.

The *hair-stuffed* tick gets lumpy—has to be “made over” every three or four years, at a greater expense each time. The musty, dusty odor of a *hair* mattress is frequently what makes sweet sleep impossible.

## SATISFACTION OF MIND

The old-fashioned HAIR mattress has distasteful and dangerous possibilities. The hair is taken from the bodies of dead beasts. Vermin and germs have doubtless lodged in it, for it cannot be strictly purified. Such a mattress will absorb moisture, and needs frequent “making-over”—which is a dirty job.

The OSTERMOOR PATENT ELASTIC FELT is purity itself, germ-free and *vermin-proof*.

OSTERMOOR mattresses *cannot* get lumpy, never need renewing; an occasional sun-bath is all they require. The tick can be taken off and washed whenever soiled.

## Send for Our Handsome 96-Page Book FREE

whether you want a mattress or not—interesting information on comfort and the OSTERMOOR. There is no other mattress as good as the OSTERMOOR, and we want you to know why—we *challenge comparison*. It illustrates the various uses to which the Patent Elastic Felt is put—Pillows, Window Seat Cushions, Boat Cushions, Church Cushions, etc.

Sold on 30 Nights' free trial—money refunded if not all you even HOPED for

Look out, whether you doubt the dealer or not, ask to see the name “OSTERMOOR”—it is sewn on the end. It is a safe thing to do—“mistakes” will happen, you know.

### OSTERMOOR & CO.

114 Elizabeth St. New York

Canadian Agency: The Alaska Feather and Down Company, Ltd., Montreal.

#### STANDARD SIZES AND PRICES:

2 feet 6 inches wide, 25 lbs., . . .	\$ 8.35
3 feet wide . . . 30 lbs., . . .	10.00
3 feet 6 inches wide, 35 lbs., . . .	11.70
4 feet wide, . . . 40 lbs., . . .	13.35
4 feet 6 inches wide, 45 lbs., . . .	15.00

All 6 feet 3 inches long.

In two parts 50c. extra.  
Special sizes, special prices.

Express charges prepaid to any place.



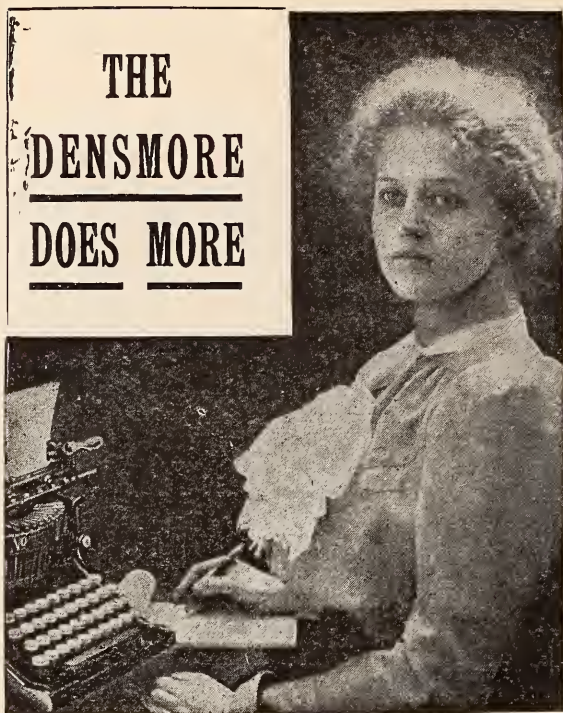

## Densmore Typewriter Company

309 Broadway New York



### Lovely Complexion FREE.

A Trial Package Mailed FREE which will give any lady a beautiful complexion. It is not a face powder, cream, cosmetic or bleach, but is absolutely pure and you can use it privately at home. It permanently removes moth patches, redness, crow's feet, pimples, blackheads, fleshworms, sallowness, freckles, tan, sunburn, and

all complexion disfigurements. Address

Madame M. Ribault, 5325 Elsa Bldg., Cincinnati, O.



### Nobuckle Suspenders

Patent Aug. 5th 1902.

"For the Comfort of Man."

Have no metal parts to rust, break or tear the clothing. Easily adjusted.

Simple, Strong, Servicable

A Year's Guarantee slip with each Pair.

At your dealer's or by mail **50c**

Regular lengths 31 to 37 inches

When you order, state height and weight.

Dept D, Russell Mfg. Co. Middletown, Conn.

Largest makers of suspenders in the world.

## BIG MONEY In Mail-Order Business

People are buying more by mail than ever before: one mail-order house does a business of a million dollars monthly; another receives 2,000 letters daily, nearly all containing money; mail order trading is unquestionably the business method of the future. The field is large, the possibilities unlimited. Let us send you our plan for starting beginners; it covers every point. Enclose stamp.

CENTRAL SUPPLY CO., Kansas City, Mo.

### DEER HUNTING IN FLORIDA.

Six years ago Anderson Smith and I planned a 10 days' trip along the Western edge of Kissiminee river valley, a section abounding in deer, turkeys and bear. We selected the week after Christmas as best suited to our absence from business, and did not neglect to take along old Bob, the darkey, who knew so well how to "bake de hoecake brown" and wake us up to drink the 4 o'clock coffee. My companions were tenderfeet of the purest strain and I soon realized that the burden of supplying our camp with venison would fall on me. One day's drive took us to the game and we found it fairly plentiful, but the deer were on the run, and too far ahead of us. Old Cuff, my faithful big, white, slow trail dog, well and truly performed his duty, but the first night found us jaded and without venison. Deer are hunted here with slow trail dogs, that is, trained to trail the deer without barking and never getting more than 40 yards from the hunter. The woods are generally open and well adapted to rifle shooting. The deer lie in low cover, such as palmetto, ganberry bushes, etc.

The second day we trailed 5 beautiful does, but they jumped too far for my 38-40. This was Smith's first shot, and he emptied his 16 shooter in beautiful style, but the bullets all seemed to take no effect on a spot of ground about 40 yards in front of him.

Two days were gone and no deer were shot. The next day I was riding into camp, and when within a short distance 3 does jumped within 75 yards of me. I stopped them all before they were out of range of my faithful old rifle.

The following night we camped on a beautiful lake, surrounded by an ideal game country. After supper I cut a pine pole, nailed it between 2 trees and swung up 5 deer, 2 young bucks having been added to the list during the day. Bob was present, assisting in the killing of the 2 bucks, and could point out his bullet holes in each one, although he could not hit a barrel standing 40 yards away.

J. R. Davis, Bartow, Fla.

**To RECREATION Readers:** I am organizing a club of subscribers for RECREATION, with a view to securing a premium, and I submit this offer; to each person sending me \$1 for yearly subscription to RECREATION, I will send a 25c Dominion of Canada bank note. There are but a few of these in circulation and I have succeeded in collecting a number of them. These are interesting souvenirs and are especially valuable to persons who are making collections of coins or other curios. Walter Legare, 518 John St., Quebec, Can.

I would as soon go without gun or camera as without RECREATION. Kindly change my address, lest I miss a copy.

L. D. Gilmore, Empire, Colo.





# Play with Bicycle Cards, and Hold Good Cards.

They always wear well. Sold by dealers. Popular price. Rider back—in continuous use for twenty years. Most popular card back ever printed. Many other designs, including new Automobile backs.

**The U. S. Playing Card Co.**  
Cincinnati, U. S. A.

We will send 128-page Condensed Hoyle for 10c. in stamps, if addressed to Department 23

RIDER BACK. ORDER BY NAME.

## KEEP YOUR HANDS WARM

Send me **2 yearly subscriptions** to **Recreation** and I will send you a pair of **Leather Hunting Gloves** made to your measure, by the **Luther Glove Co., Berlin, Wis.**

*Sample copies for use in canvassing furnished on request*

## 6% for 7 Years, and then 100% Every Year For More than a Lifetime.

The 6 per cent per annum for 7 years (equal to 42 per cent of your principal) is guaranteed by a disinterested and responsible Trust company. The 100 per cent per year thereafter is assured upon the maturing of a product as indispensable to our modern civilization as wheat — or cotton — or coal; which can be sold every day in the year, in every market in the world, and at a stable price that has been steadily advancing for many years.

No such proposition as this has ever before been presented to you. Every person who has \$200 or more to invest should investigate this offer.

Our facts and figures are proven by U. S. Government reports. The plan is absolutely unique and perfectly safe-guarded; all we ask is a chance to show it to you.

On an investment of \$1000 this offer means a return of \$60 per year for seven years (\$420), and then an income of \$1000 per year permanently for you or your heirs.

Our literature explains our plan fully and concisely, and *proves every statement*. We will send it to you immediately on request.

**Mutual Production Company,**  
80 Milk St., Boston, Mass.

# THE LATEST, SAFEST AND BEST CANVAS BOAT

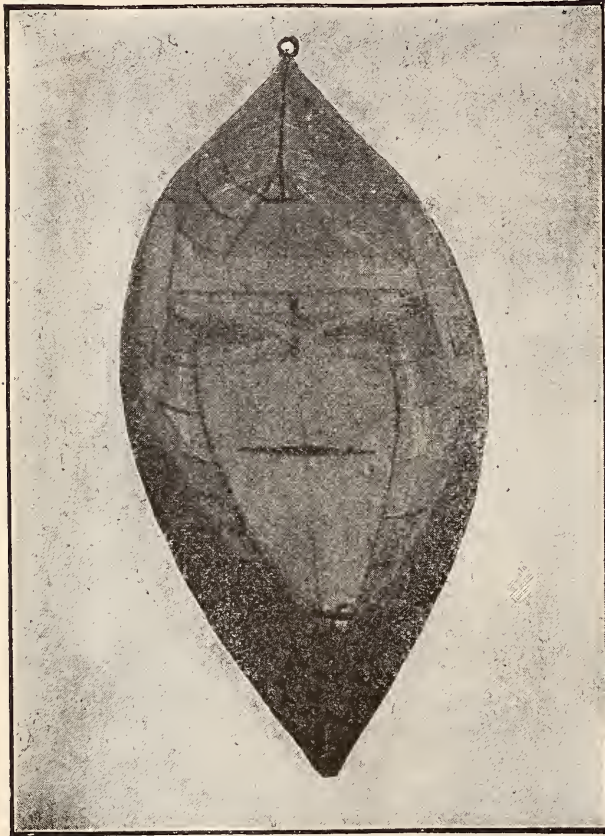

Is what we offer you. A Boat built on modern lines that will prove a pleasure to own and use. Selected materials used throughout, and it comes to you **guaranteed** the best. A handy and safe boat for fishing and shooting. Send 4 cents in stamps for catalogue and reliable testimonials.

Mention RECREATION.

**LIFE SAVING FOLDING CANVAS BOAT CO.**  
Kalamazoo, Mich.



Latest patent and improved Canvas Folding Boat on the Market. Puncture proof. Tempered steel frame. No bolts to remove. Folds most compact of any boat made.

## Mullins' Metal Boats



**"Get There" Duck Boat** in use. Be sure and order one for your Fall shoot. Approved by sportsmen wherever used. Send for catalogue, with prices, etc. Mention RECREATION.



**"PRINCE."** 14 ft., square stern model. Especially adapted for family and livery use.

\$30 crated on cars, Salem.

**W. H. MULLINS**

228 Depot St.

Salem, Ohio

DO YOU WISH TO IMPROVE YOUR SHOOTING? IF IT IS AS GOOD AS IT CAN BE, DO YOU WISH TO KEEP IT SO? IN EITHER CASE, THE J. C. HAND TRAP WILL BRING WITHIN YOUR REACH THE FULL ADVANTAGE OF A SHOOTING RANGE. THESE TRAPS WILL SUCCESSFULLY THROW ANY OF THE CLAY TARGETS NOW IN USE, GIVING A LIFE LIKE REPRESENTATION OF A BIRD IN FLIGHT. I WILL SEND YOU A J. C. HAND TRAP FOR 5 YEARLY SUBSCRIPTIONS TO RECREATION. SEND IN YOUR CLUB NOW, AND IMPROVE ON YOUR SHOOTING.



11-foot Special

# Folding Canvas Boats

were not satisfactory until the "**KING**" was produced. It is a revelation in boat construction. Nothing like it ever made. **Nonsinkable. Can't tip over. Punctureproof.** Wear longer than a wooden boat. **No Repairs.** No cost for storage. **Always ready.** Folds into a small neat package,—**carry by hand.** Used by the U. S. Navy. They are simply wonderful. A thoroughly patented article. Beware of imitation. Made only by ourselves.

A catalogue of 70 engravings and 350 testimonials sent on receipt of 6 cents.

MENTION RECREATION.

## King Folding Canvas Boat Co.

Kalamazoo, Mich., U. S. A.

---

# HERE IS ANOTHER!

If you will send me

## Thirty Yearly Subscriptions

to

# RECREATION

I will send you

## A No. 10 Goerz Trieder= Binocular Field Glass

Listed at \$38.00

Every well-informed man knows the great power of this modern prismatic field glass. It is indispensable to every hunter, and is one of the latest and best on the market.

I have but a few of these instruments on hand and the offer will be withdrawn as soon as the supply is exhausted. Therefore, if you want one

### START IMMEDIATELY

---

Sample copies of RECREATION for use in canvassing furnished  
on application

I am 5 to 8 hours' ride from the best of big game hunting. Our game comprises wild water buffaloes, deer, alligators, pigeons, ducks, doves, snipe, wild chickens and wild hogs.

The mountain buffalo (*carabao*) is a most dangerous animal when wounded. Several hunters have recently had narrow escapes from charging *carabao*. An American constabulary officer whom I know recently had a desperate encounter with a wounded buffalo bull. The officer saved his life, but had 2 ribs broken and received severe flesh wounds. I have reason for believing that the wild *carabao* of Luzon is one of the most dangerous animals on earth.

The 30-40 army rifle does not seem to be a suitable weapon for hunting *carabao*. Personally I should prefer a 45-70 .500 or 50-100-450 repeater. I have only seen one full grown wild *carabao* and was armed at the time with a 30-30 Winchester carbine. I failed to stop the game.

A. M. Macnab, Tumanini, P. I.

I received the Carpenter tent, my premium for a club of 18 subscribers to RECREATION, and I am well pleased with it.

Chas. A. Pearson, Elkhart, Ind.

RECREATION is a welcomed magazine in our home. I enjoy reading it as much as my husband does.

Mrs. De W. Salisbury, Bakersfield, Cal.

## AT A BARGAIN

A new 26-foot Launch, fitted with 3 H. P. Iowa Engine. Immediate delivery. Write for particulars.

**Iowa Marine Engine Works**  
Bellevue, Iowa

### Do You Want a Drinking Cup Free?

Send me \$1 for a new subscription to RECREATION and I will send you a fine nickel-plated folding drinking cup. For 10 cents extra will send by registered mail. Mrs. Thomas H. Walker, 295 Merrimac Street, Manchester, N. H.

## THE HILDEBRANDT SPINNER



For Fly Fishermen. A spinner which spins, and also catches fish. Strictly hand-made and of the best material. No swivel required. Made with all kinds of Feather and

Buck-tail flies. For sale by dealers. Sent on receipt of 25c.

**J. J. HILDEBRANDT, Logansport, Ind.**



**ACME FOLDING BOAT CO., MIAMISBURG, O.**

U. S. Government who prefer our boats. Received medal and award at Chicago World's Fair. If you investigate we will get your order. Mention RECREATION.

**Acme Folding Boat Company, Miamisburg, O.**

# FAY & BOWEN

## Motors & Launches

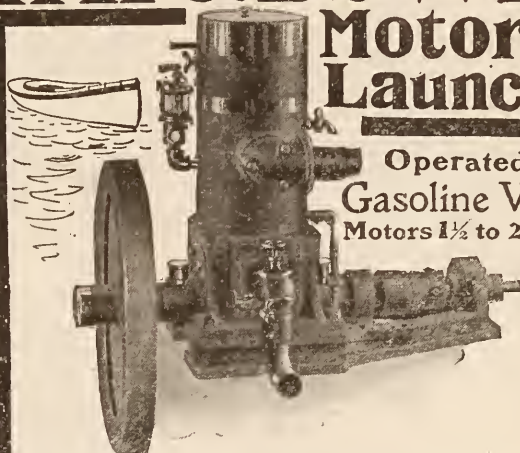

Operated by  
Gasoline Vapor  
Motors 1½ to 25 H.P.

THE Fay & Bowen Marine Motor is a revelation to those who have used others. Reliable, safe, durable and easy to operate. Remarkable speed control. Best of all, it starts when you start it. No handle or crank is used. Our patent igniter is absolutely unique and always instant and positive in action. It is really the only perfect and satisfactory igniter.

Motors complete from 1½ to 25 H. P. ready for installation. We also build handsome launches with motors installed and ready to run

Send for Catalogue.

**Fay & Bowen,**

28 Mill Street,

Auburn, N. Y.

## Yacht Race Pictures

The only complete set of

### ART PICTURES

of the

**INTERNATIONAL YACHT RACES**  
**RELIANCE AND SHAMROCK III.**

in all three races, can be had, 14x17,

**LIPPINCOTT CARBON PROCESS**

on slabs of celluloid or painters' canvas, ready to frame. These are magnificent art productions and must be seen to be appreciated. Better than oil paintings. Satisfaction guaranteed or money refunded. Send for booklet, Dept. No. 1.

**OLIVER LIPPINCOTT, Artist,**

South and Mulberry Sts. Newark, N. J., U. S. A.

## MARINE GAS ENGINES

Experts for years have ranked our engine with the highest grade, and it is now being copied by other builders. We always endeavor to be on top and for 1903 offer an engine built from brand new patterns, with **NEW** and **ORIGINAL** features—just what other engines will have five years hence. If you want to be in the lead send for catalog fully describing all parts, and then buy a "Rochester".

**ROCHESTER GAS ENGINE CO.**

700 Driving Park Ave.

Rochester, N. Y., U. S. A.

**CHAMPION**



**DOG BISCUIT**

Formerly called  
**HOREJS' DOG BISCUIT.**

Write for Samples and Prices to  
**ST. PAUL BREAD COMPANY,**  
Mention RECREATION. **St. Paul, Minn.**



**One Hand Controls THE DURYEA**

No bewildering array of levers, gauges or other intricacies—one hand does it all. A *twist* of the *wrist* not only steers it, but accelerates or retards the pace from a position of luxurious ease. **THE DURYEA PHAETON** is the acme of motor carriage perfection. Its long springs and large wheels obviate all jar and give greatest possible comfort. No machinery in front to annoy passengers by odor, or in sight to mar appearance. The result of twelve years' experience of the oldest motor vehicle builders in America. Triple Gasoline Motors. Speed up to 40 miles per hour. Fuel for 100 mile run. Large bronze bearings.

**Duryea** vehicles are most durable and economical in fuel and tires of any built. **No pumps, no trouble.**

**Duryea's** excel under all conditions.

Fastest American **solene** carriage, Nelson Hill, 1901; won Chicago Times-Herald 50 mile race through more than a foot of snow, and other races in Europe and America. They lead the way today.

Send for catalogue of the eight styles—also booklets. They will interest you.



**DURYEA POWER CO., 314 Hockley St., Reading, Pa.**

While returning my thanks to friend MacCarrick for his interesting articles on military rifles, I still think the single action Remington, for quick firing, ahead of any single action rifle and almost as good as a repeater. If the government had a lot of good guns on hand and wanted to alter them to breech loaders, then, and then only, the Springfield is a good thing. Nothing will satisfy me, however, but the best, for our army, and the fact that the government is now exchanging the Krag for a clip action gun settles the matter. The reason for choosing a 38 caliber for an all around rifle is that a small ball with a light charge of powder can be used for ducks and other small game, and the large cartridge for bear, etc. Though our forefathers killed deer and bears with a single shot, small bore, I know of one instance in which a common black bear charged the hunter after being shot through the body, from shoulder to flank. It was shot 3 times more, the last bullet tearing off the top of the skull at short range before the charge ended. A heavy 45 rifle was used.

The Savage people have, besides a good gun, an immense advantage in their shells. The small, coated bullet with small charge of smokeless is great on ducks, geese and other small game. To shoot well with a rifle requires much practice. If you buy shells ready loaded, their cost will soon stop the practicing. Why can not smokeless shells be made sloping instead of bottle necked? It would be an advantage in resizing.

For some time past I have made it a rule to buy sporting goods only from people advertising in RECREATION. If we all do that it may aid our favorite magazine in a pecuniary way.

Jno. A. Elliott, M. D., Northumberland, Pa.

**For Exchange:** A Remington Single Shot Gun, 38-55 caliber, in good condition. for Winchester or Colt, 22 caliber.

**Wanted:** Young bear cub. State age and price. W. L. S, care RECREATION.

**FOR SALE**

The entire stock and good will of my Taxidermy Department, including mounted and unmounted birds, animals, elk and deer heads, reptiles, skeletons, rugs and shells.

Must sell on account of being compelled to devote my time to other departments.

This is one of the finest collections of its kind in the country.

Would be suitable for museum or curio hall. Will sell cheap.

**EDW. S. SCHMID**

712 Twelfth Street N. W.

Washington, D. C.

**\$12.00 PER WEEK**

If you have a small space in your cellar, garden, or roof you can make \$12 per week working for us—**NO CANVASSING, AND NO OUTFIT NEEDED.** The work will take about **ONE HOUR A DAY.** We buy the result of your work **FOR CASH.** Work can be done by **LADIES AND GENTLEMEN.** Full instructions and contract for one year sent on receipt of addressed envelope, **Co-operative Produce Co., Dept. J, 111 Nassau St., New York.**



## SPORTSMEN SAVE YOUR BEAUTIFUL TROPHIES. LEARN TAXIDERMISTRY BY MAIL.

Adorn your home and office with the prizes of the chase. **Increase your Income.** Add tenfold to the pleasures of field sports. Make your gun a source of profit.

We teach the mounting of Birds, Animals, Heads, Tanning Skins and Furs, and collecting Insects and Eggs, successfully by correspondence. Standard methods, (no so-called "rapid systems" or "embalming") skilled faculty, reasonable tuition, satisfaction guaranteed. **Endorsed by all leading Taxidermists and Standard Sporting Magazines.** Now is the ideal season to study Taxidermy. Interesting catalog FREE. It's yours for the asking.

**Write to-day.**

### The Northwestern School of Taxidermy, (Inc.)

411 A Bee Bldg. The original and only School of Taxidermy in the World Omaha, Nebr.

When I first got my Savage I received 300 rounds of ammunition manufactured and guaranteed by the W. R. A. Company. I obtained good results with the shells and thought I had the best gun put up. Not knowing there was a difference in shells, I next bought U. M. C. adapted shells. My gun shot low and I lost some easy shots at game. One of the shells did not contain any powder, merely a cap and bullet. Result, bullet in barrel; no antelope. I got more W. R. A. shells, but results were no better. I concluded the gun was worn out. Bought more Winchester shells and maintained the old-time velocity and elevation. I then concluded the trouble was caused by the ammunition. I also used U. M. C. shells loaded with Savage powder and found them all right, but adapted shells bring poor results. Montana is flooded with them. I am now using the Savage Arms Company's own shells, Nos. 1 and 2, and find the old gun is not worn out.

Two Savages, Castle, Mont.

**Free**—To each person sending me \$1 (post-office money order) for one year's subscription to RECREATION, I will send choice of a Braided Leather Dog Whip, with a steel snap on end, or a Polished Steel Dog Chain, with swivels, snaps, etc., or one dozen assorted Trout Flies, silk bodies, good ones, or a Pocket Compass, one inch dial, open face, watch shape, with ring handle and bevel crystal. Also a special offer limited to the months of June, July, August and September of a nickel plated multiplying 40 yard raised pillar reel, balance handle with click, drag and free running for two subscriptions. For four subscriptions a genuine 6 strip Split Bamboo or Fly Rod, 4 pieces with grips, silk whipped, nickel plated mountings, solid metal reel seat, length about 9½ feet.

Edward S. Adams,  
Box 536, Manchester, N. H.

## Squab Book Free



Squabs are raised in 1 month, bring big prices. Eager market. Astonishing profits. Easy for women and invalids. Use your spare time profitably. Small space and capital. Here is something worth looking into. Facts given in our FREE BOOK, "How to make money with Squabs." PLYMOUTH ROCK

SQUAB CO., 11 Friend St., Boston, Mass.

**FREE!** Complete instructions for preserving and mounting Birds, Game Heads, Fishes, etc., etc., and also how to dress Skins with hair on for rugs and robes.

Hunters, Trappers, Anglers, Collectors and all others interested in saving trophies for decoration or sale, send stamp for free instruction. Mention RECREATION.

**MORRIS GIBBS, M. D.**

Level Street

Kalamazoo, Mich.

**Taxidermists' Glass Eyes for Stuffed Birds and Animals**  
Oologists' and Entomologists' Supplies **Materials**

Send 5c. in stamps for catalogue

**FRED. KAEMPFER, 88 STATE ST., Chicago, Ill.**

Taxidermy work done in all its branches

Mention RECREATION

## FOR SALE

The largest collection of Game Heads, Horns, and Antlers in America. A total of TWO HUNDRED AND FIFTY SPECIMENS, including many record heads and exceptional freaks and rarities. Full information and catalogue on application.

**A. E. COLBURN**

Bond Building,

Washington, D. C.

## CUBAN BIRDS

I now have a collector in the field on the Island of Cuba, and will be able to supply specimens of any birds desired.

**R. D. HOYT, Taxidermist**  
SEVEN OAKS, FLORIDA

## Adirondack Sportsmen

Have your deer heads mounted by

**H. J. LESSER, Johnstown, N. Y.**

\$8 for first-class work. Also mount feet for racks, stools, &c. Skins dressed, \$1. Skins manufactured into gloves at reasonable prices.

**FINE MOUNTED GAME HEADS, BIRDS, ETC., for sale at unheard-of prices.**

Send 10 cents for photos.

JOHN CLAYTON, Taxidermist, Lincoln, Maine

## FRESH RICE SEED FOR SALE

Chas. Gilchrist, Port Hope, Ontario, Can.

---

# SLEEP

IS TIRED NATURE'S  
SWEET RESTORER

After a hard day's tramp, you must have

## A Good Night's Rest

in order to fit you for the next day's work. Better to sleep on a good bed without your dinner, than sip at a banquet and then sleep on the cold, hard, wet ground. You can get

## A Recreation Camp Mattress

of rubber, with valve for inflating, made by the Pneumatic Mattress Co., and listed at \$18.

For 10 Yearly Subscriptions to  
**RECREATION**

---

*Send for Sample Copies*

Address RECREATION, 23 West 24th Street, New York



# Newhouse Traps

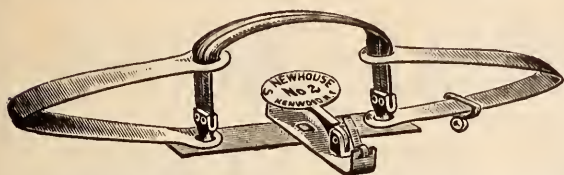

THE STANDARD FOR OVER FIFTY YEARS

Used by all professional hunters and trappers, who find that

**The Best Trap is the Cheapest**

Complete illustrated catalogue on application.

ONEIDA COMMUNITY, LTD, Kenwood, N. Y.

MORE

# DuPONT SMOKELESS

Is shot than all other Powders combined.

Gunners, therefore, must consider

# DuPont Smokeless

THE BEST

Practical Common Sense in 6 Sizes.

## CAMP STOVE

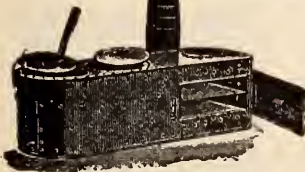

Either with or without oven. The lightest, strongest, most compact, practical stove made. Cast combination sheet steel top, smooth outside, heavy lining in fire

box and around oven, holds its shape, telescopic pipe carried inside the stove. Burns larger wood and keeps fire longer than any other. Used by over 9,000 campers and only one stove returned.

For catalogue giving full particulars, mention RECREATION and address,

D. W. CREE, Manufacturer, Griggsville, Ill.

THE

# 1902 Model

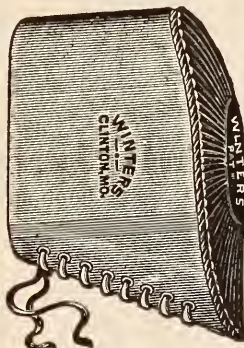

LEATHER-COVERED Pneumatic Recoil Pad is now perfect. No pump, no valve, no recoil, no flinch, no headache, no bruised shoulders, no money if not satisfactory and returned at once. PRICE \$2.

**J. R. WINTERS**  
Clinton, Mo.

## INDIAN CURIOS

WHOLESALE & RETAIL CURIO DEALERS' SUPPLY DEPOT.

Bead Work, Baskets, Elk Teeth, Mexican Goods, Fossils, Minerals, Arrow-Heads, Pottery, Alaska Ivories, Shells, Agates, Photos, Great stock, Big Cata. 5c., stamps. Mention RECREATION. If a dealer, say so.

L. W. STILWELL

DEADWOOD SO. DAKOTA



## KOENIG'S SHELL EXTRACTOR.



Every shooter should have one—carry it in a vest pocket. Fits any gauge shell. Koenig's Gun Catalogue, Free.

10 Cts. Postpaid.

E. G. KOENIG, NEW JERSEY'S LARGEST GUN HOUSE

SOUTH BROAD ST., NEWARK, N. J.

# BRADLEY'S ANTI-RUST ROPES!

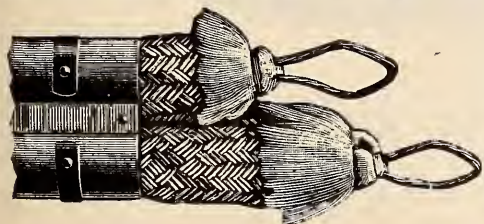

For SHOT GUNS, RIFLES and REVOLVERS. They cannot rust or pit if these ropes are used. No more worrying to keep your fire arms in perfect condition. Sent postpaid, \$1 per set for Shot Guns; 50c. for Rifles; 25c. for Revolvers. Give gauge and length of barrel. Send for circular giving full particulars.

## BRADLEY'S SHOT GUN SIGHT

Makes wing shooting easy and certain. Scores greatly increased at trap and in field. Instantly attachable and detachable. Price, post-paid, 50 cents. Send for circular.

Address C. L. BRADLEY, CLARKSVILLE, TENNESSEE. Mention RECREATION.

# WANTED

Every owner of a shot gun to learn all about our handy little Target Trap.

*A Card Brings the Information*

Mention RECREATION.

THE MITCHELL MFG. CO., London, Ohio

# SQUIRES' SIBERIAN MOOSE HUNTING BOOTS AND SHOES

The **leather** is waterproof, fine grained, tough and pliable. The **linings** are russet calfskin. The **soles** are best waterproof anhydrous oak leather, **stitching** of silk, English back stays, bulldog toes, extra heavy **eyelets**, **Pratt fasteners** and **hand made throughout**.

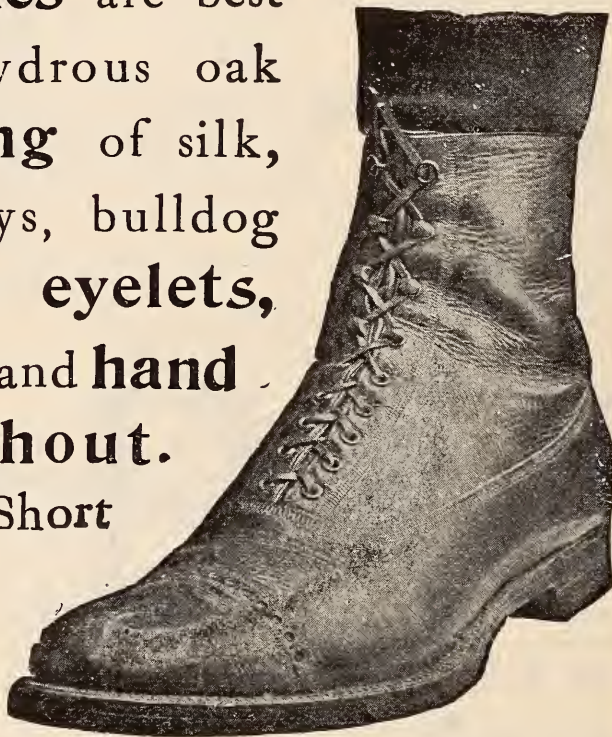

Price, \$7.50 net. Short

Boots \$8.50,

Knee Boots, \$10,

Cavalry Style

Boots \$12. Special circular giving detailed information free for the asking.

Mention RECREATION

MADE ONLY BY

## Henry C. Squires & Son

20 Cortlandt Street, New York

## SOME GOOD GUIDES.

Following are names and addresses of guides who have been recommended to me, by men who have employed them; together with data as to the species of game and fish which these guides undertake to find for sportsmen.

If anyone who may employ one of these guides should find him incompetent or unsatisfactory, I will be grateful if he will report the fact to me.

## ALASKA.

Edwin Edclmann, Kenai, Cook's Inlet, moose, bear, caribou, mountain sheep, ducks, grouse and trout.

## FLORIDA.

Carson Bros., Frostproof, bear, deer, turkeys, quail, snipe.

C. H. Stokes, Mohawk, deer, alligators, turkey, quail, and snipe.

## IDAHO.

John Ching, Kilgore, elk, bear, deer, antelope, mountain sheep, trout and grouse.

Chas. Petty's, Kilgore, ditto.

## MAINE.

H. R. Horton, Flagstaff, deer, bear, moose, caribou, fox, grouse and trout.

W. C. Holt, Hanover, moose, caribou, deer, grouse and trout.

## MONTANA.

A. R. Hague, Fridley, elk, deer, mountain sheep, bear, grouse and trout.

Chas. Marble, Chestnut, ditto.

## NEW YORK.

Le Roy Still, Bayport, Long Island, ducks, quails, rabbits and grouse.

## WASHINGTON.

Munro Wyckoff, Port Townsend, deer, bear and grouse,

## WYOMING.

S. N. Leek, Jackson, elk, bear, deer, mountain sheep, antelope, grouse and trout.

James L. McLaughlin, Valley, elk, bear, deer, mountain sheep, antelope, grouse and trout.

## CANADA.

Wm. S. Andrews, Lillooet, B. C., deer, bear, mountain sheep, goats, grouse and trout.

B. Norrad, Boiestown, N. B., moose, caribou, grouse and trout.

Carl Bersing, Newcastle, N. B., moose, caribou, deer, bear and grouse.

## NEWFOUNDLAND.

John C. LeMoine, Birchy Cove, Bay of Islands, caribou salmon and trout.

**BIG GAME IN MEXICO.** Bear, Mountain Lion, Jaguar, Deer, Antelope, Mountain Sheep, Wild Hog, Timber Wolf, Wild Turkey. We have a comfortable Hunting Lodge in the heart of the Sierra Madre, in Sonora, Mexico, 2½ days from El Paso, Texas. Our outfit is complete and we furnish everything and make your trip here one that will be pleasantly remembered.

**Rates: \$2.50 a day.** No extra charge for guides. Correspondence solicited. Mention RECREATION.

P.O. Address **CHIHUAHUITA LODGE**  
Colonia Pacheco, Chihuahua, Mexico

## You Need This

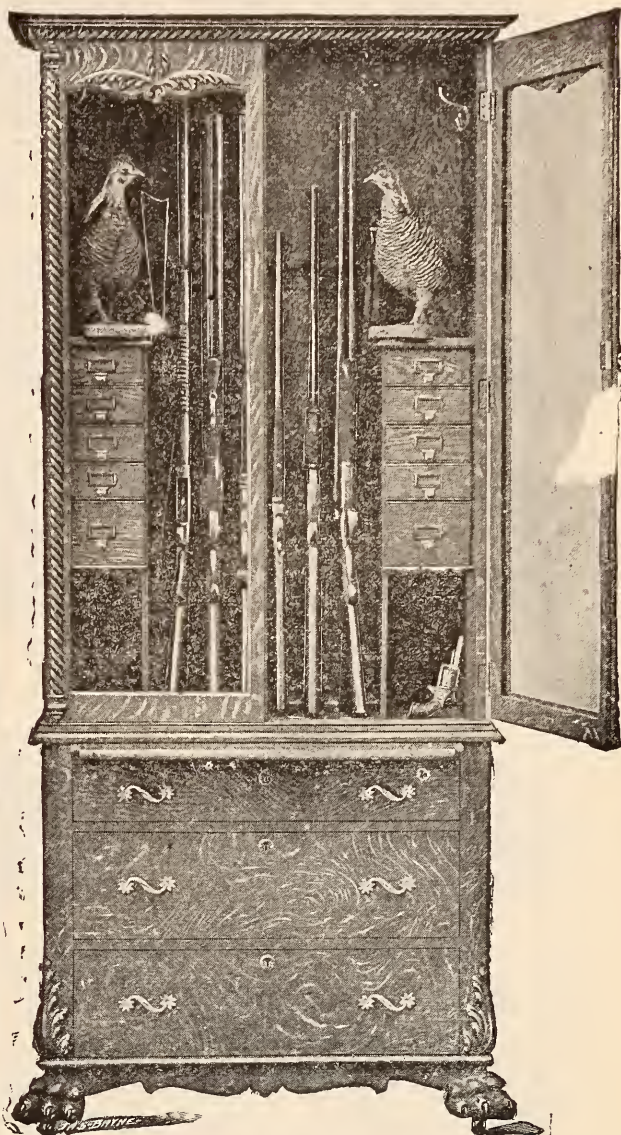

## If you see one, you'll buy it.

To fully appreciate the convenience of a sportsman's cabinet, you must have one in your home. Up-to-date sportsmen want their guns, ammunition, etc., handy. You wouldn't believe how ornamental a cabinet is till you see one with your outfit nicely arranged in it. We are selling them to the most noted sportsmen in every state and territory in the United States and you should be on our list too.

We make cabinets from \$17.50 to \$48.00. Send stamp for descriptive catalog.

Mention RECREATION.

**West End Furniture Co.,**

SOLE MFRS. AND PATENTEES.

**WILLIAMSPORT, PA.**

Date, \_\_\_\_\_ 190

G. O. SHIELDS,

Editor and Manager of RECREATION, 23 West 24th St. New York.  
Herewith find \$1.00 for which please send me RECREATION one year  
beginning with \_\_\_\_\_ number,

Name, \_\_\_\_\_

Remit by P. O. or Express Money Order, or New York Draft.

DETACH THIS, FILL OUT, AND SEND IN

RELICS OF A DISAPPEARING RACE

# Buffalo Skulls

WITH POLISHED OR  
UNPOLISHED HORNS

Also polished or unpolished horns in pairs or single. Polished horns tipped with incandescent electric lights; polished hunting horns; mirrors hung in polished horns, etc. These are decided novelties and are in great demand for sportsmen's dens, offices, club-rooms, halls, etc. Send for illustrated catalog. Mention RECREATION.

E. W. STILES

141 Washington St. Hartford, Conn.

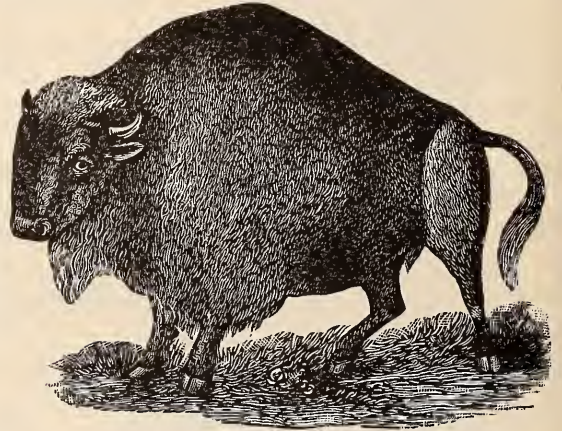

The Laughlin fountain pen which you sent me for securing subscriptions to RECREATION arrived O. K. It works nicely and I thank you very much for it.

Douglas R. Prindle, New York City.

This is an out-of-the-way place, where books are few and far between, and where such a magazine as RECREATION will receive a warm welcome.

Henry W. Stevens, Portland, Me.

## APPLICATION FOR MEMBERSHIP IN THE L.A.S.

ARTHUR F. RICE, Secretary L.A.S., 23 W. 24th St., New York.

DEAR SIR: Enclosed \$1 for membership fee for one year.

I certify that I am eligible to membership in the L. A. S. under the provisions of the constitution, and refer to 2 League members (or to 3 other reputable citizens) named hereon.

Name \_\_\_\_\_

Street or P.O. Box \_\_\_\_\_

City or Town \_\_\_\_\_

References

Detach this, fill out and send in.

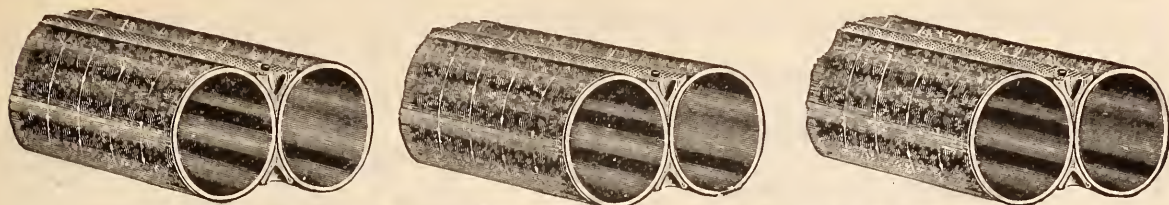

# ITHACA GUNS

TAPER  
GRACEFULLY  
TO THE MUZZLE

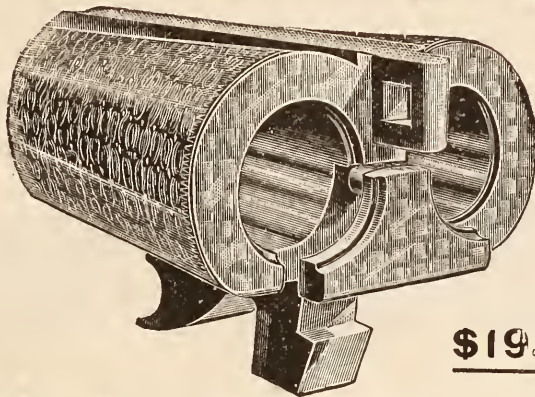

HAVE  
DOUBLE-THICK  
NITRO BREECH

CROSS  
BOLTED

16 GRADES

\$19.50 TO \$300

ITHACA GUN CO., ITHACA, NEW YORK

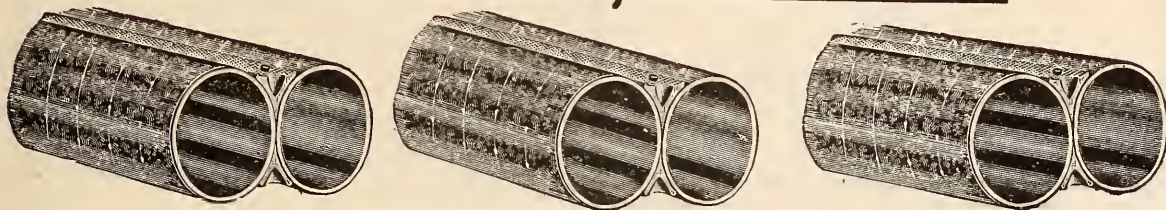

Following are extracts from a few of the many letters received by the Northwestern School of Taxidermy, Omaha, Neb.:

"Worth 10 times the price you charge."

"Am delighted with my investment."

"Can't supply the demand for mounted ducks."

"It has given me new interest in outdoor life."

"My office is beginning to resemble a museum. The work is exceedingly attractive to visitors."

Could not get along without RECREATION.  
C. S. Conant, Concord, N. H.

Excellent Quail and Turkey Shooting in Brunswick county, Va. Hunting privilege under State laws, \$10. First-class accommodations, including services of guide and privilege of bringing dog, \$15 a week. Game abundant. Season opens for quails October 15; for turkeys, October 20. Address Miss Margaret Buford, Lawrenceville, Va.

I got this club of 12 in about 2 hours, and later will send you another. RECREATION is one of the best journals of its kind I have ever seen.

J. C. Coffing, Cameron, Mo.

We make a specialty of Featherweights  
and Trap Guns with our new  
SINGLE TRIGGER



Guaranteed  
Perfect

Our New  
Perfect  
Gun Cleaner  
By Mail,  
30 Cents

Send stamp  
for 1903 Catalogue  
Mention RECREATION

**D. M. LEFEVER SONS & CO.,**

Manufacturers of the "NEW LEFEVER"

**SYRACUSE, N. Y.**

Not connected with Lefever Arms Co.

**Robin Hood  
Smokeless Powder**

**Factory Loaded  
Ammunition**

**WHY NOT TRY THEM?  
OUR CLAIMS**

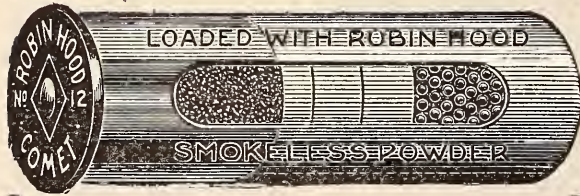

**QUALITY AND PRICE**

Send for "POWDER FACTS."  
It tells the whole story.

Mention RECREATION.  
Manufactured by

**The ROBIN HOOD POWDER CO.**  
Swanton, Vt.



**"Collan-Oil"**

preserves leather and  
renders shoes and  
harness positively

**WATERPROOF**

Used by the U. S.  
the Army and Navy,  
and National Guard.

Send 25c. for trial can.  
**AGENTS WANTED**

Write for terms and circulars

**J. R. BUCKELEW**

Dept. A. 111 Chambers St., N. Y.

**How is your Muscle?**

Would you like to build it up?

**How are your Lungs?**

Would you like to expand them?

**How is your Circulation?**

Would you like to improve that?

If so, send me **6 yearly subscriptions**  
to RECREATION, accompanied by a money  
order for \$10, and I will send you a new

**PROFESSIONAL  
PUNCHING BAG**

made by H. D. CRIPPEN, No. 52 Broadway,  
New York and listed at \$6.95.

There is a frame with the bag that you can attach to  
a door casing, a window casing or a wall, or a board  
fence, or anywhere else you may see fit to put it, and  
you will thus have a small gymnasium of your own.  
The Crippen bag is one of the liveliest ever devised,  
and if you will put 20 minutes a day on it, for a month,  
you will find a wonderful improvement in your muscle  
and your health.

Sample copies of RECREATION, for use in canvassing,  
will be mailed free.

**The Best Yet:**—To any person sending  
me \$2, express or money order, for one  
year's subscription to RECREATION, I will  
give free, one fine 3 joint bamboo rod, 7 to  
9 feet long, one nickel plated 60 yard  
multiplying reel, and 50 yards of water-  
proof silk line. This outfit, including  
RECREATION, would cost \$6. Or I will  
give the above outfit for 7 yearly sub-  
scriptions to RECREATION. Or I will give  
the 50 yards of silk line, listed at \$1, for  
one subscription and 25 cents extra. This  
line is a very fine outfit and would retail  
in any store at \$1.  
C. W. Jacobs, 339 N. 2nd St., Coshocton, O.

**THE MALCOLM RIFLE TELESCOPE**

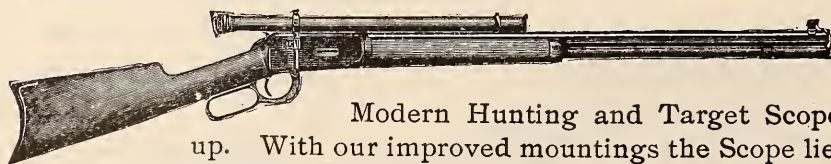

Modern Hunting and Target Scopes from 3-power  
up. With our improved mountings the Scope lies close to the barrel. Our  
"Rough Rider" of 3-power is an ideal hunting glass. Our "Bulls Eye" at 5 to  
8-power is perfection itself for both hunting and target purposes.

SEND FOR 1903 CATALOGUE

Mention RECREATION.

**THE MALCOLM RIFLE TELESCOPE MFG. CO.**

F. T. CORNISH, Mgr.

# T. W. STAKE

## Hammerless Gun

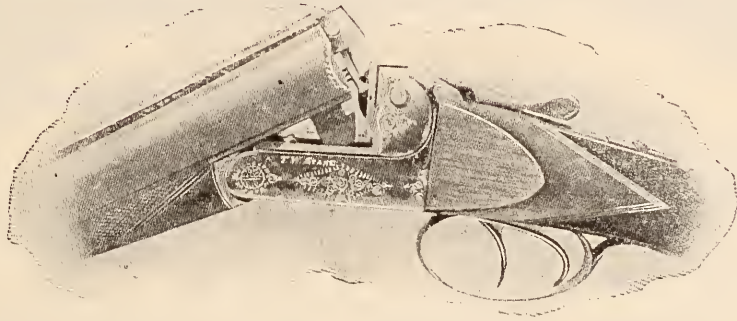

Responding to the wide demand for a moderate priced Field Gun of light to medium weight, perfectly safe, balancing and handling like a high-grade gun, we offer this first-class pattern, made for us in accordance with our ideas by a well-known gun-maker.

A thoroughly good, safe gun, good enough and yet not so expensive as to make one careful in field, or wood or brush. A gun to knock about in boat or wagon and entirely reliable in safety and killing qualities.

Anson and Deeley System locks, round cross bolt, Purdy fore-end, side clips, double bolt on the lugs, finely engraved locks French walnut stock, Krupp's fluid steel barrels, matted rib, 12, 16 or 20 gauge, 5½ to 7½ lbs., cylinder, modified or full choke.

**Price, = = \$60**

*Specialty Catalogue mailed on receipt of 5 Cents*

Mention RECREATION.

## SCHOVERLING, DALY & GALES

302-304 Broadway, New York

# THE PARKER AUTOMATIC EJECTOR



The Latest attachment to  
The "OLD  
RELIABLE"

New York Salesroom, Send for Catalogue. PARKER BROS.,  
32 WARREN ST. Mention RECREATION. Meriden, Conn.

## AN IMPORTANT OFFER

For 2 Yearly Subscriptions to RECREATION

I will send you

### A RIFLE WICK PLUG

Made by HEMM & WOODWARD, Sidney, Ohio, 30 caliber  
up to 50 caliber.

OR

### A SHOT GUN WICK PLUG

20 gauge up to 10 gauge

For 3 Yearly Subscriptions to RECREATION

### A Pair of Shot Gun Wick Plugs

20 to 10 gauge.

Sample copies for use in canvassing furnished on  
application.

Address RECREATION, 23 W. 24th St., N. Y. City

**Free:** To anyone sending, through me, \$1 for yearly subscription to RECREATION, I will send free a No. 1 Sportsman's Medicine Case; for 2 subscriptions a Physician's Pocket Medicine Case; for 10 subscriptions 1,000 12-gauge primed paper shot shells. This offer is not open to old subscribers who formerly have sent in their subscriptions to the office of RECREATION, but to all others.

Walter Lusson, Ardmore, Pa.

**Free:** If you send your subscription to RECREATION through me or direct to the office to be placed to my credit, I will send you free of charge, any one of the articles mentioned below:

Shot gun bench crimper, sells for 75 cents, in 10-12 16-20 gauge.

Shot gun cleaning rod, three attachments, sells for 50 cents, in 10-12 16 gauge.

Micrometer powder and shot measure, adjustable, and for both black and smokeless powder, sells for 65 cents.

U. S. Government rifle cleaner, any caliber, with attachments, sells for 60 cents, packed in neat canvas bag.

A duck, snipe or turkey call, sells for 75 cents each, best made.

A hand painted sporting picture, suitable for framing and just the thing for your den, worth \$1.50.

"Hunting in the Great West," by G. O. Shields. H. S. Hill, 815 11th Street. N. E., Washington, D. C.

**For Sale or Exchange:**—A new 30-30 Winchester with Lyman sights and a new 22 Winchester with Lyman No. 2, 6 and 5 sights. T. Batte, Albion, Neb.

# THE BAKER

THE GUN  
THAT'S SAFE



SO DURABLE TOO  
IT LASTS A  
LIFETIME

If you want to be right up in the front rank of style and efficiency shoot one of our **Special Paragons** with *Whitworth* or *Krupp fluid steel barrels*. We have other patterns also that would please you. Our "Quarterly" tells about them and other matters that would interest you. We will send it to you *free a year* if you want it.

**BAKER GUN & FORGING CO., 42 Liberty Street, Batavia, N. Y.**



# H. Q. R. SINGLE SHOT GUN

---

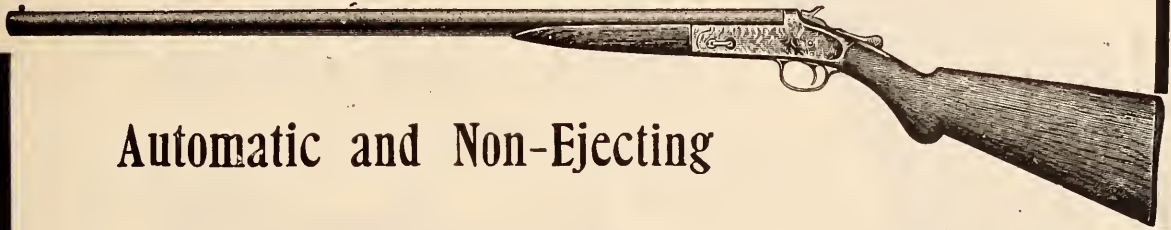

Automatic and Non-Ejecting

The cheapest absolutely safe gun,  
with improvements found hereto-  
fore only in the highest priced

**PERFECT IN MODEL AND CONSTRUCTION  
SIMPLEST "TAKE DOWN" GUN MADE**

*12, 16, and 20 gauge; barrels 28, 30 and 32 inch,  
plain steel and twist. Top snap; cen-  
ter hammer; rebounding lock*

Your dealer can supply, or we will  
sell to you direct. Write for Catalog

---

**HARRINGTON & RICHARDSON  
ARMS CO.**

Dept. R,

WORCESTER, MASS.

*Makers of H. Q. R. Revolvers*

# Winter Is Coming

## GET A PAIR OF SKATES

For yourself, your best girl, or your brother, or for some other girl's brother, or for any one you love, and who is fond of skating

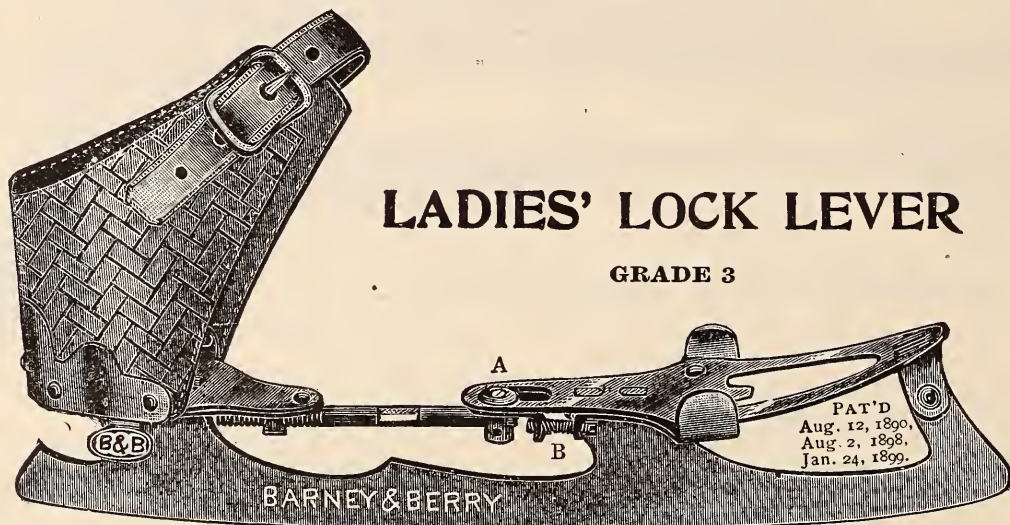

For 5 Yearly Subscriptions to **RECREATION**  
I WILL SEND YOU

A pair of Lock Lever Skates

OR

A pair of Ladies' Lock Lever Skates

Grade 3, made by Barney & Berry, Springfield, Mass.

### LOCK LEVER

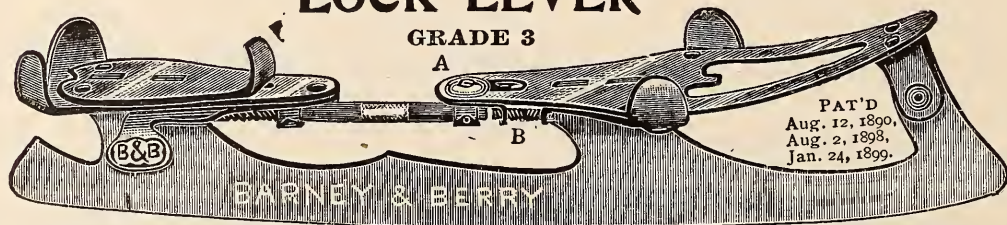

As every skater knows, these are the best skates made in the world.

The winter season is approaching, and you could scarcely select a more appropriate present

FOR A MAN, OR A WOMAN,  
A BOY OR A GIRL,

than a pair of these high-grade skates. Only a limited stock on hand, and when these are gone this offer will be withdrawn.

Sample copies of **RECREATION** for use in canvassing furnished on application.

I have been testing the Peters and the Winchester cartridges. First I tried both makes in a 32-20 revolver, using Peters semi-smokeless and Winchester black powder cartridges. The effect of the bullets on game was much the same; but the effect of the powder on the gun was decidedly different; 6 shots with Peters dirtying the gun more than 12 with the other.

Next I tried both makes in a Winchester 30-30 rifle, using soft nose bullets. First day I used Winchester shells, shooting a coyote at 161 steps. Only one bullet hit him, but it killed. The next day I tried Peters ammunition and got a shot at another coyote at 195 steps. It knocked him down but he got up and escaped. A few days later I had a similar experience with Peters cartridges. That time I brought a coyote down at 125 yards and again at about 300 yards, but still he got away.

**Free:**—I will give anybody sending me a subscription or renewal, any one of the articles named below:

Ideal Shell Closer, 10-12-16 gauge, sells for 50c.

Ideal Shell Loader, 10-12-16 gauge, sells for 50c.

Perfection Gun Oiler, can not spill when not in use, worth 50c.

Web Shot Shell Belt, 10-12-16 gauge, sells for 75c.

Henry B. Floyd, 723 Eighth St., N. W., Washington, D. C.

**The Best Offer Yet.**—To any person who will subscribe to RECREATION for one year through me I will send free a small water color landscape, hand painted, suitable for framing; or a hand painted silk bookmark. For two subscriptions I will send a fine Mexican opal scarf pin worth ordinarily from \$1 to \$1.50.

Don M. Harris, 308 Crawford Road, Cleveland, Ohio.

**For Sale.**—Lefever Hammerless Shot Gun; quality E, 10 gauge, 28 inch barrels. In A1 condition. Cost \$100. Also fine Sole Leather Carrying Case, (new) cost, \$10. Gun and Case for \$50., if taken at once. C. W. Peak, Peakville, N. Y.

# Hamilton

TAKE DOWN Rifle

\$2.

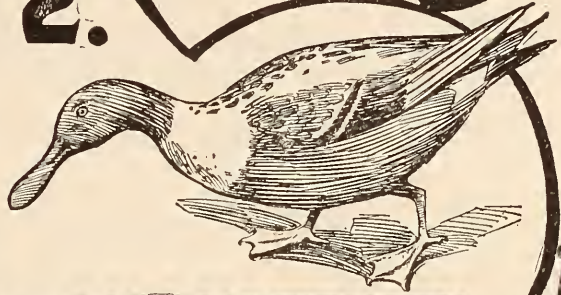

## Shooting With

the Hamilton Rifle, Model No. 19, affords unlimited enjoyment and sport. It is in every respect an ideal firearm, is strong, yet light and well balanced. Shoots 22 caliber long or short cartridges. For small game or target practice it has no equal. **Price, \$2.00.**

Our No. 15 Model, with a 4-in. shorter barrel, is practically the same weapon reduced to boys' size. Price, \$1.50. Ask your dealer to show you Hamilton Rifles. If he cannot, write us for illustrated folder—it's yours for the asking. Hamilton Rifle Co., Box 64, Plymouth, Mich.



# Cedaroleum!

## The New Lubricant and Rust Preventive

It is colorless and you can use it anywhere on your gun or rifle. Manufactured of the purest chemicals, it meets a demand and need.

It is better than any oil or vaseline.

It is a specific for cleaning rifles and guns after using nitro powders, as well as black. Its peculiar substance makes it the finest lubricant for the mechanism.

It is put up in a neat tube with injector and is handy to carry in your pocket wherever you go.

Send for sample to-day. **Price, 15 Cents.**

Mention RECREATION.

**CEDAROLEUM COMPANY**

Trademark Registered.

**Perkinsville, Vt.**

## THE DAVENPORT Hammerless No. 2

With Full Length Matted Top Rib



### OUR LATEST

Without a PEER for the Trap.

Send for latest edition of our catalogue—just out.

Mention Recreation

Our "Brownie" Rifle is in great demand amongst the "boys"—22 caliber only  
**The W. H. Davenport Fire Arms Co., Norwich, Conn.**

# Rare and Valuable Books

I have for sale a few bound copies of Vol. III of RECREATION, July to December, inclusive 1895; also of Vols. IV and V. including the entire issues of 1896; Vols. VII, VIII, XII, XIII, XVI, XVII, and XVIII. All these are filled with interesting and valuable matter. The intervening volumes, are nearly all out of print, and can never be replaced at any time.

Vol. III sells at \$2.

Vols. IV and V, one book, at \$3.

All others \$2 each.

Here are a few titles that will suggest the value of these rare books, to lovers of fields and sports:

The San Juan Islands.....	Maj. John Brooke, U.S.A.
The Lord Eagle of the Storm.....	Chief Simon Pokagon.
The Cowboy and the Wheel.....	James B. Adams
Two Moose and Three Bear.....	Dr. Hamilton Vreeland
Hunting Big Game with a Camera.....	George Shiras, 3d
The Fight on Soppa Creek.....	Capt. Wheeler, U.S.A.
My Best Shot.....	Hon. W. A. Richards, ex-Gov. of Wyo.
A Prairie Pastoral.....	E. L. Kellogg
Woodcock on the Islands.....	F. W. G. Johnson
Crossing the Rockies in '61.....	Major W. H. Schieffelin
Salmon Fishing in Labrador.....	Col. Charles E. Fuller
Coursing with Greyhound.....	L. F. Bartels
A Bald-Faced Grizzly in Camp.....	M. W. Miner
A Deer Drive with Spokane Indians.....	Lieut. W. R. Abercrombie
Pheasant Shooting.....	Thomas G. Farrell
Sitting Bull's Last Medicine.....	Margaret G. Brooks
A Mountain Lion Hunt.....	Dr. Robert Meade Smith
Trouting on Clark's Fork.....	Gen. F. W. Benteen, U.S.A.
A Youthful Guide and a Prize Bighorn.....	Hon. I. N. Hibbs
The First Day of the Chicken Season.....	A. B. Cowie
Goose Shooting in Colorado.....	W. E. King
The Cowboy's Version of the Prodigal Son.....	Pony Bill
Trouting on the Thunder.....	A. D. Curtis
A Bad Grizzly.....	George W. Kellogg
My Wife's Moose.....	W. E. Bemis
How We Photographed the Wild Cat.....	Coyote Bill
Elkland .....	Ernest Seton-Thompson
Hunting Mountain Sheep in a Snowstorm.....	Capt. S. A. Lawson
Grouse in New Hampshire.....	Old Bill
Foxes in the Big Swamp.....	C. P. Franklin
On the Chilkat Pass.....	H. L. Suydam
A Rangeley Vacation.....	C. J. Halpen
Pierre's Stratagem.....	H. D. Leadbetter.

There are many other stories in the books equally interesting. You should enrich your library at once by adding to it one of each of these rare volumes.

# FIRE SALE

500 GUNS AT REDUCED PRICES

**GREAT  
BARGAINS  
IN  
FINE  
GUNS**

By a fire in our Ware-rooms on June 9th a part of our stock of Fine Guns and Sportsmen's Goods was partially damaged by water, and we shall close them out at greatly reduced prices to make quick sale.

W. C. Scott & Sons, Premier and other grades — Greener, Langs, Parkers, Remington, Ithaca, and all the leading makes.

Also other articles in Sportsmen's Goods, Athletic Goods, Bicycles, Cutlery, etc.

Send two stamps for List of Guns, showing sizes, etc.

**THE CHANCE  
OF  
THE YEAR**

**WILLIAM READ & SONS**  
107 WASHINGTON STREET, BOSTON, MASS.

ESTABLISHED 1826



**IDEAL PAPER SHOT SHELL TRIMMER**  
**SOMETHING NEW.**

With it you can cut off the soft and frayed ends of shells that have been fired and they will be *as good as new*. Why throw *good shells away*? Send us 6 cents in stamps for *latest IDEAL HAND BOOK*, giving full information of *all New Goods* and much matter of interest to shooters. Address,

**IDEAL MANUF'G CO., 12 U St., New Haven, Conn., U.S.A.**

PRICE **\$1.50**  
Special List.

WIRE CUT FROM ANY LENGTH

THE PHIL. B. BEKEART CO., of San Francisco, Cal., Agents for Pacific Coast.

When you write please mention Recreation.

**Something Special — Playing Cards Free:** — To each person sending me \$1 for one year's subscription to RECREATION, or sending it direct to be placed to my credit, I will forward, all charges prepaid, a pack of elegant gold edge playing cards. These are no cheap second quality cards but first quality, of extra selected stock, highly enameled and polished, fancy set pattern backs, each pack wrapped in handsome glazed wrapper and packed in strong telescope case.

L. J. Tooley,  
428 Portage St., Kalamazoo, Mich.

## The Buffalo Is Well Nigh Extinct

And every nature lover wants a relic of him. Here is a chance to get it:

I have in stock a limited number of buffalo horns, highly polished and fitted with nickel plated flanges at the base, so that they can be screwed on the wall, thus forming

## A Novel and Effective Gun Rack

So long as the supply lasts I will give a pair of these horns for

### 3 Yearly Subscriptions to RECREATION

Sample copies for use in canvassing furnished on request. Address

Recreation, 23 W. 24th St., New York

Recent articles in RECREATION in regard to Peters shot gun ammunition, remind me of an experience I once had with some of those shells. I had been using U. M. C. ammunition, but as the dealer was out of that I was persuaded to try Peters.

I bought 50 shells and with a companion using the same ammunition, went on a hunting trip. When we put up the first covey of quails we each gave them both barrels, and as the birds were in an open field we were surprised that none fell, but thinking it our own fault we went on. The same thing was repeated several times before we blamed the ammunition we were using for our lack of success.

We shot all day over fine quail ground and bagged only 2 birds each. On returning home we determined to test the power of the shells. We put up a white pine board at 30 yards for a target, and after each shot examined the board. Few shot stuck in the wood; most just made an indentation the size of the shot and dropped out. It is needless to say that was my last attempt to use that kind of ammunition.

With U. M. C. or Winchester ammunition a person can be sure of his game if he does his part properly. I also find the rifle ammunition of the 2 firms mentioned above to be just as represented.

C. B. Corson, M. D., Altoona, Pa.

**Do you enjoy big game hunting?  
Or Trout Fishing?  
Or Mountain Climbing?**

**If so, write us and we can accommodate you.**

We keep 65 head of horses. We employ a full corps of experienced guides, packers, and cooks.

We have a complete outfit of riding saddles, pack saddles, tents, stoves, cooking utensils, tableware, and everything necessary for touring and camping in the Mountains.

We live at Banff. The Eastern gateway of the Canadian Rockies.

And can send you anywhere you may wish to go from this point

*North, East, South or West.*

**Address: BREWSTER BROS.  
Banff, Alberta, Canada.**

# ONE OF THE 9 "SYRACUSE" Built for Business.



COPYRIGHTED 1903

SYRACUSE ARMS CO.

This picture shows the result of a  
**SINGLE SHOT** from a **SYRACUSE**  
**16 GAUGE**

THREES OF THIS KIND ARE HARD TO BEAT

Write for a  
Syracuse  
CAT.

**SYRACUSE**  
**ARMS CO.**

**SYRACUSE, N. Y.**

Mention RECREATION.

“Had I believed in you ten years ago,  
Doctor, my wife could have been saved”



Why did he delay?

A penny risked—a postal card—  
and his wife might have been well.

For later I cured the man.

No doubt I could have cured  
his wife.

Sick one—delaying—doubting—  
this is a lesson for you.

# Dr. Shoop's Restorative

Fill out the coupon. Send to me. I will arrange with a druggist near you for six bottles of Dr. Shoop's Restorative. Take it a month at my risk. If it succeeds, the cost is \$5.50. If it fails the druggist will bill the cost to me. And I leave the decision to you.

## Let Me Explain To You

Mine is the largest medical practice in the world—I say this, not boastfully, but to explain.

Where most physicians—other specialists even—treat forty cases I probably treat thousands. I have done that year after year, and experience—more than all else—teaches a physician to cure.

My practice was large before I made my discovery—how to treat, not the vital organs themselves, but the nerves that operate them.

Now I have patients all about you—your neighbors; your friends perhaps. Few of them care for the guarantee. They know the remedy—Dr. Shoop's Restorative—and its value. But I offer the guarantee cheerfully—gladly, to new patients, that those who are sick may learn without risk.

My past records show that 39 out of 40, who accept my offer, pay for the medicine—and pay gladly.

Would they pay if it failed?

The offer is everywhere. Over 600,000 sick ones have accepted it. Failure would bankrupt me. Yet I continue the offer—and to everyone everywhere.

Could I if it failed?

## Simply Fill Out the Coupon

That is all. No reason to wait—nor to postpone. Nothing to consider—no preparations to make.

The risk is mine and mine alone.

You or some friend is sick. I can help you. The sun shines brightest on well days. My offer brightens the dark days. Then sign the coupon today.

Let me hear from you now.

DR. SHOOP'S RESTORATIVE

## At the Doctor's Risk

Dr. Shoop, Box 1214  
Racine, Wisconsin  
Send me book No. \_\_\_\_\_  
and tell me where I can  
secure six bottles Dr.  
Shoop's Restorative on  
30 days' trial.

Book 1 on Dyspepsia  
Book 2 on the Heart  
Book 3 on the Kidneys  
Book 4 for Women  
Book 5 for Men (sealed)  
Book 6 on Rheumatism

Name \_\_\_\_\_

City \_\_\_\_\_ State \_\_\_\_\_

Street \_\_\_\_\_

Write plainly

ROBERT JOHN CO. CHI



# DIAMONDS ON CREDIT

HERE is the boiled down story of the **LOFTIS SYSTEM** of selling **Diamonds and Watches on Easy Payments** to people hundreds of miles away and of whom we never heard until receiving their request for our **Catalogue**. Our catalogue shows the finest genuine **Diamonds** mounted in every conceivable and artistic form, at prices considerably lower than the home jewelers would ask for spot cash. From our catalogue you select any **Diamond** that you would like for yourself, or which you would like to give a friend or loved one; send one-fifth of the price, and very soon thereafter it will be handed to you at your home or place of business, as you prefer, with all express charges fully paid. Now, examine it as critically as you like and if it is not the best bargain you ever saw in **Diamonds**, and perfectly satisfactory in every way—send it back at our expense, and **your money will be refunded instantly**.

**You will want to keep it** for you can do so and pay the balance in eight equal monthly payments. We charge no interest; require no security and create no publicity; everything is confidential, prompt and satisfactory. Some people prefer not to send money in advance, in which case we send the **Diamond** to their Express Office or Bank with all charges paid, where they may call and examine it and make the first payment. Most persons, however, prefer to see the **Diamond** at home and have absolute possession of it and the fullest opportunity for examination, before deciding to buy. Every **Diamond** sold is guaranteed in writing, and may be exchanged at full price for a larger stone at any time in the future. We frequently exchange for **Diamonds** which we sold ten or twenty years ago. You need not hesitate to accept any representation which we make, and you may assure yourself on this point by asking your local bank about us. They will refer to their Commercial Agency records and tell you that our reliability, promptness or responsibility is not questioned in the business world. **You can make no mistake in buying a Diamond or Watch from us for we guarantee satisfaction.** If you want a watch—we sell them on the same easy terms. We are perhaps the largest retailers of high-grade **Watches** in America. **Diamonds** are advancing rapidly in value and are the best investment in sight at present. As a method for saving small amounts monthly, there is nothing equal to a **Diamond** purchase. You have the security in your possession; you have all the pleasure and prestige that comes from wearing a **Diamond**, and you have a certain annual increase of from ten to twenty per cent in value. If you prefer to pay cash, we will give you a bill of sale with any **Diamond**, giving you the option of returning the **Diamond** at any time within one year and receiving spot cash for full amount paid, less ten per cent, the reasonable cost of doing business. **For Example:** You may wear a Fifty Dollar **Diamond** for a year, then send it back to us and receive \$45.00 in cash. You may have all the pleasure and prestige of wearing a beautiful **Diamond** a whole year for \$5.00 or less than ten cents per week.

**It is none too early to begin to think of Christmas. Better send for our Catalogue at once. With it before you, you can tell us exactly what you would like,—do it, then leave the rest to us under our written guarantee and you will be well satisfied.**

**LOFTIS BROS. & CO.**

Diamonds - Watches - Jewelry  
Dept. L-82 92 to 98 State St.  
**CHICAGO, ILL.**  
Established 1858

THE  
ORIGINAL  
LOFTIS  
SYSTEM,

**THE ONLY ONE THAT WORKS**

"LAKE SHORE LIMITED":

Leaves New York 5.30 every afternoon via NEW YORK CENTRAL  
Arrives Chicago 4.30 next afternoon via LAKE SHORE

# SAVAGE



**The SAVAGE** 25-35, 32-40 and 38-55 calibers are some sizes recently added to the famous 303 and 30-30 Model 1899 Hammerless Repeater. These loads are considered the standard for accuracy and will probably never be excelled for hunting and target purposes. Savage Rifles are fitted with "Special Smokeless Steel" barrels, and with a breeching mechanism *originally* constructed to withstand the enormous pressures developed by modern smokeless powder. This gives confidence to "the man behind the gun." *Catalogue G with full particulars mailed on request.*  
SAVAGE ARMS COMPANY, UTICA, N. Y., U. S. A.

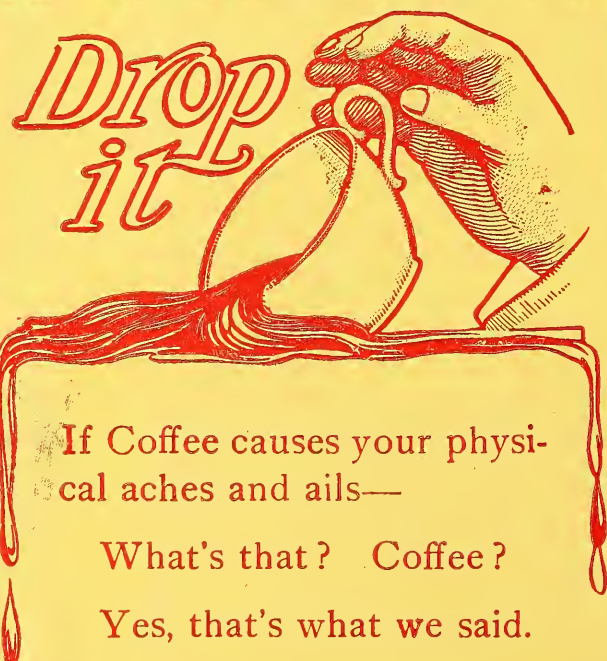

If Coffee causes your physical aches and ails—  
What's that? Coffee?  
Yes, that's what we said.  
You can convince yourself when you find the delicious bound and spring of returning health in ten days after you leave off Coffee and take on Postum Food Coffee.  
There's a reason.

## Club Cocktails



Famous the world over for purity. They never vary. The secret of their perfect blend is that they are kept six months before being drawn off and bottled. Be sure you have them in your camp, on the yacht, and on your outing trips wherever you go. They are ready and require no mixing. Simply pour over cracked ice.

For Sale by all Fancy Grocers and Dealers

**G. F. HEUBLEIN & BRO.**  
29 BROADWAY, N. Y. HARTFORD, CONN.

# VOSE

**PIANOS** have been established over 50 YEARS. By our system of payments every family in moderate circumstances can own a VOSE piano. We take old instruments in exchange and deliver the new piano in your home free of expense. Write for catalogue D and explanations.  
VOSE & SONS PIANO CO., 160 Boylston St., Boston, MASS

# RECREATION

By J. E. TYLOR, illustrated with  
photos by the author.

LOST IN THE DEVIL'S GARDEN;

OFFICIAL ORGAN OF THE LEAGUE OF AMERICAN SPORTSMEN



CAMPWARD BOUND.

ANONYMOUS.

PUBLISHED BY G. O. SHIELDS (COQUINA)  
23 WEST 24TH ST., NEW YORK

TWO RATTLING GOOD TURKEY STORIES IN THIS ISSUE,  
BOTH ILLUSTRATED. READ THEM



# California

A CLUB DINNER is chiefly noted for its high-class quality. Choicest cuts, tropical delicacies and superior service.

Club meals are the kind always served on **The California Limited.**

Daily service of THE CALIFORNIA LIMITED will be resumed late in November; until then semi-weekly. Chicago to Los Angeles, San Diego and San Francisco. See Grand Canyon of Arizona en route.

Our illustrated booklets, mailed free, will help you rightly plan a California tour. Address General Passenger Office, Atchison, Topeka & Santa Fe Railway, Chicago.



ALL THE WAY

# RECREATION

Copyright, December, 1902, by G. O. Shields

A Monthly Magazine Devoted to Everything the Name Implies

\$1.00 A YEAR.  
10 CENTS A COPY.

G. O. SHIELDS (COQUINA),  
Editor and Manager.

23 WEST 24TH STREET,  
NEW YORK

## CONTENTS OF THIS NUMBER

	PAGE,
Down Over the Old Buena Vista Trail Came a Lone Horseman.....	FRONTISPIECE
The Mystery of Stirrup Ranch. Illustrated.....	H. N. BEECHER 331
Tex. Poem. Illustrated.....	J. H. SMITH 335
Elk in Wyoming. Illustrated.....	S. N. LEEK 337
De Huntah's Jubilee. Poem.....	FRED W. GOSHORN 338
A Turkey Hunt in New Mexico. Illustrated.....	J. E. BECK 339
September Poem.....	C. C. HASKINS 340
A Turkey Hunt of Long Ago. Illustrated.....	M. B. 341
Our Hunt at Fence Lake, Mich.....	JOE A. BOTTKOL 343
Picture Making with the Aid of the Camera Illustrated.....	K. ROWA 345
Huntsman Come. Poem.....	C. G. RIDEOUT 346
In the Upper Peninsula. Illustrated.....	A. B. RICHMOND 347
Bill Brown's Retriever.....	PALMER C. GOBLE, JR. 351
Four Surprises at Once.....	JACK WOOD 352
Lost in the Devil's Garden. Illustrated.....	J. E. TYLOR 353
My Balsam Pillow. Poem.....	MEDA 357
To My Pipe. Poem.....	ARNOLD TOWNSEND 358
Duck Shooting on Ipswich Bay.....	M. R. LOVETT 359
Heliographing on Mount Adams.....	C. E. RUSK 361
A West Texas Hunt.....	HON. H. S. MORAN 365
Deer in Colorado.....	M. S. BACON 367
When My Ship Comes In. Poem.....	A. L. VERMILYA 368
From the Game Fields.....	369
Fish and Fishing.....	373
Guns and Ammunition.....	376
Natural History.....	386
The League of American Sportsmen.....	389
Forestry.....	393
Pure and Impure Foods.....	395
Editor's Corner.....	397
Amateur Photography.....	404

Entered as Second-Class Matter at New York Post-Office, Oct. 17, 1894.



## WELL DRESSED MEN

appreciate the great utility and  
comfort of

### WASHBURNE'S PATENT SCARF HOLDER

Little but effective. It cannot come loose or  
ride up. Instantly attached and detached.

Scarf Holder	- - -	10 Cents	} Sent Pre- paid.
Cuff Holders	- - -	20 "	
Key Ring and Chain	- - -	25 "	

They never come loose. A tiny lever with  
a bulldog grip. Illustrated Catalogue Free.

AMERICAN RING CO., Dept. 44  
Waterbury, Conn.

## Skin Diseases

If you suffer from Eczema,  
Salt Rheum, Ringworm, Itch,  
Acne, or other skin troubles,

## Hydrozone

will cure you.

As these diseases are caused by para-  
sites, killing them without causing injury  
to the healthy tissue cures the trouble.  
It has cured many cases pronounced  
incurable and is absolutely safe.

Hydrozone is a scientific Germicide.  
Used and endorsed by leading physicians.  
It is absolutely harmless, yet a most pow-  
erful healing agent.

Trial bottle at your druggist or by  
mail on receipt of 25 cents. None gen-  
uine without my signature on label.

*Prof. Charles Marchand*

F-59 Prince St., New York.

# DO YOU WANT A FOLDING CANVAS BOAT ?

If So, Send Me

## 35 Yearly Subscriptions to RECREATION

AND I WILL SEND YOU

### A 14 ft. King Folding Canvas Boat

LISTED AT \$48

capable of carrying 2 men and an ordinary camp outfit. There are thousands of these boats in use, and nearly every man who is using one of them praises it on every occasion.

Sample copies of RECREATION for use in canvassing will be furnished on application.

Address 23 West 24th St., New York

# HIGGINS & SEITER

West 21<sup>st</sup>. and 22<sup>nd</sup>. Streets, New York.  
Near Sixth Avenue.



Tomato Set—Set complete, 12 plates, 1 dish and case made in exact reproduction of a tomato. \$19.50



Cut Glass Sugar Bowl  
2 pieces complete, \$3.00



Cut Glass Creamer  
2 pieces complete, \$3.00

TO DO ONE OF TWO THINGS EVERY reader of RECREATION is cordially invited

Visit personally the Great China and Glass Warehouses of HIGGINS & SEITER on West 21<sup>st</sup> and 22<sup>d</sup> Sts., near 6<sup>th</sup> Ave. Acknowledged to be the most practically interesting of any collection in the world.

Or send for the HIGGINS & SEITER Catalogue No. 14 U, itself a work of Art, free to all who would avail themselves of the Higgins & Seiter policy.

"1-4 LESS THAN ELSEWHERE."



Cut Glass Vase  
12 inch, \$4.50 10 inch, \$3.00



Cut Glass Mayonnaise Dish  
2 pieces complete, \$5.00

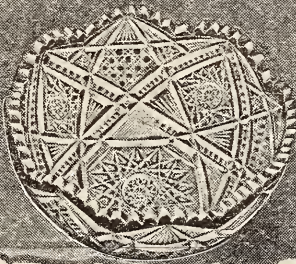

Cut Glass Salad Bowl  
8 inch, \$4.50 9 inch, \$6.75



Cut Glass Claret Jug  
11 inches high, each, \$7.50

"BUY CHINA & GLASS RIGHT."

# A CHRISTMAS PRESENT

FOR YOUR WIFE  
YOUR MOTHER  
YOUR SISTER  
OR YOUR BEST GIRL

For 25 Yearly Subscriptions to RECREATION

I will send you a set of

**1 DISH AND 12 TOMATO PLATES**

made by HIGGINS & SEITER, 50 W. 22d St., N. Y.

LISTED AT        -        -        =        \$19.50

AND

For 20 Yearly Subscriptions to RECREATION

I will send you a set of

**12 Watermelon Plates**

Listed at        -        =        \$16.50

[See Illustration]



THESE are fine, thin, white china plates, beautifully hand painted, with pictures of tomatoes and tomato vines, or watermelons and watermelon vines, in natural colors, and each set of plates is enclosed in a case made in an exact imitation of a large tomato or a watermelon.

No more beautiful or appropriate present could possibly be

found for a lady than one of these sets.

You can earn one of them in a few hours, and at the same time earn the everlasting gratitude of the lady to whom you may give it.

Send for package of sample copies for use in canvassing.



# Haunts of Fish and Game

Unexcelled Fishing and Shooting

in the

## “HIGHLANDS OF ONTARIO”



A WEEK'S HUNT IN THE LAKE NIPISSING DISTRICT.

## OPEN SEASONS

**DEER**—November 1st to November 15th. Plentiful in “Muskoka Lakes District”, “Lake of Bays” region, “Maganetawan River”, “Lake Nipissing” District and Georgian Bay region.

**MOOSE**—November 1st to November 15th in the “Highlands of Ontario,” and October 15th to November 15 in the Temiskaming and Tamogami Districts.

**DUCKS**—September 1st to December 15th.

**PARTRIDGE**—September 15th to December 15th.

Magnificent sport assured in the Districts mentioned. Write for handsome illustrated descriptive book giving all information pertaining to game laws, the regions to go to, maps, and all particulars. Copy sent free on application to

G. T. BELL

General Passenger and Ticket Agent, Grand Trunk Railway System  
MONTREAL

Are You an  
Amateur  
Photographer ?

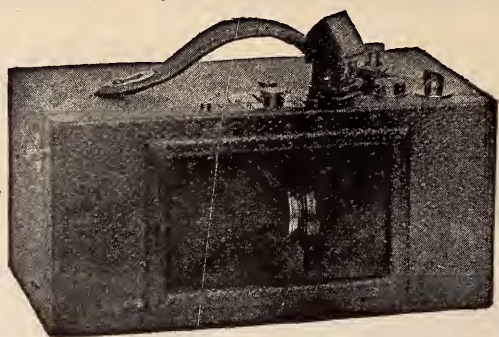

If so would you like a Camera  
that will photograph

A whole range of mountains  
A whole sweep of river  
A whole army  
A whole fleet of ships  
A whole city

Or any other vast stretch of scenery or moving  
objects ? THE SWING LENS DOES IT

The

**Al Vista**

Is the thing. It lists at \$30

One of the greatest inventions of the age.  
Given as a premium for 12 subscriptions.

For particulars Address

**RECREATION**

23 West 24th Street

NEW YORK CITY

# Don't Forget!

WHEN YOU BUY a ticket don't forget to tell the ticket agent plainly that you wish it over the Lake Shore & Michigan Southern Railway. You will secure the best in travel that money can buy.

## Nineteen Through Trains

In daily service over the Lake Shore & Michigan Southern Railway between the cities of Chicago and Toledo, Cleveland, Buffalo, St. Louis, Indianapolis, Cincinnati, Pittsburg, New York and Boston, in connection with the New York Central, Boston & Albany, Pittsburg & Lake Erie and Cleveland, Cincinnati, Chicago & St. Louis Railroads.

Send for booklet, "Privileges for Lake Shore Patrons," contains useful information; also "Book of Trains."

Address, A. J. SMITH, G. P. & T. A., Cleveland, Ohio

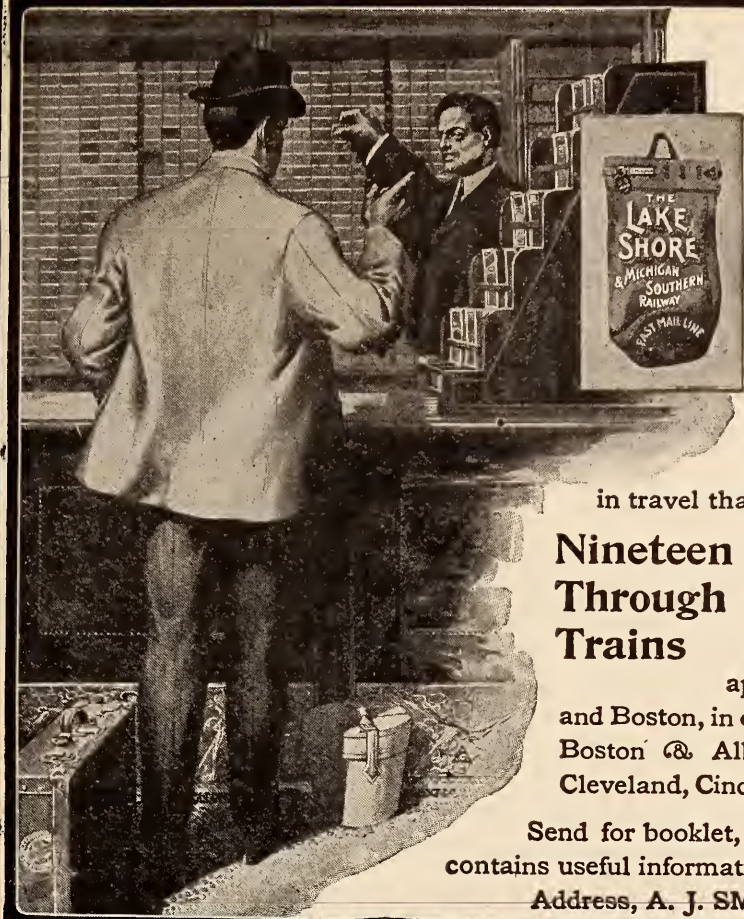

## THE FOUR-TRACK NEWS

An Illustrated Magazine of Travel and Education

MORE THAN 128 PAGES MONTHLY.

Its scope and character are indicated by the following titles of articles that have appeared in recent issues:

- |  |                      |
|--|----------------------|
| Footprints of Columbus in Spain—Illustr'd, | Frederick A. Ober    |
| A Watch with a History—Illustrated,        | N. S. Olds           |
| A Journey Among the Stars—Illustrated,     | Frank W. Mack        |
| In the Great North Woods—Poem,             | Eben E. Rexford      |
| Where Puritan and Pilgrim Met—Illust'd,    | Hezekiah Butterworth |
| In Rip Van Winkle's Land—Poem,             | Minna Irving         |
| Nature's Chronometer—Illustrated           | H. M. Albaugh        |
| Abandoned Farms—Illustrated,               | Howard W. Coggeshall |
| The Three Oregons—Illustrated,             | Alfred Holman        |
| Ancient Prophecies Fulfilled—Illust'd,     | George H. Daniels    |
| The Stories the Totems Tell—Illust'd,      | Luther L. Holden     |
| A Little Country Cousin—Illustrated,       | Kathleen L. Greig    |
| The Mazamas—Illustrated,                   | Will G. Steel        |
| When Mother Goes Away—Poem,                | Joe Cone             |
| A Little Bit of Holland—Illustrated,       | Charles B. Wells     |
| The Romance of Reality—Illustrated,        | Jane W. Guthrie      |
| The War Eagle—Illustrated,                 | Mary L. Austin       |
| Under Mexican Skies—Illustrated,           | Marin B. Fenwick     |
| Niagara in Winter—Illustrated,             | Orrin E. Dunlap      |
| Little Histories—Illustrated:              |                      |
| Old Fort Putnam,                           | William F. Lampton   |
| Charter Oak Chair,                         | Bessie H. Dean       |
| The Confederate White House,               | Herbert Brooks       |

SINGLE COPIES 5 CENTS, or 50 CENTS A YEAR.

Can be had of newsdealers, or by addressing

GEORGE H. DANIELS, Publisher,

Room 48

7 East 42d Street, New York



# DURYEA

No bewildering array of levers, gauges or other intricacies—one hand does it all. A twist of the wrist not only steers it, but accelerates or retards the pace from a position of luxurious ease. **THE DURYEA PHAETON** is the acme of motor carriage perfection. Its long springs and large wheels obviate all jar and give greatest possible comfort. No machinery in front to annoy passengers by odor, or in sight to mar appearance. The result of twelve years' experience of the oldest motor vehicle builders in America. Triple Gasolene Motors. Speed up to 40 miles per hour. Fuel for 100 mile run. Large bronze bearings.

Duryea vehicles are most durable and economical in fuel and tires of any built. **No pumps, no trouble.**

Duryea's excel under all conditions. Fastest American gasolene carriage, Nelson Hill, 1901; won Chicago Times-Herald 50 mile race through more than a foot of snow, and other races in Europe and America. They lead the way today.

Send for catalogue of the eight styles—also booklets. They will interest you.

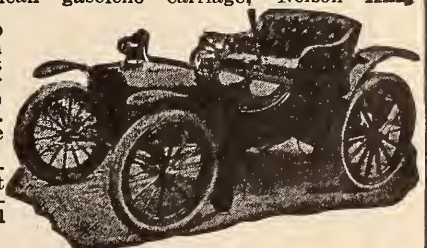

DURYEA POWER CO., 314 Hockley St., Reading, Pa.

# J. M. Hanson's Clubbing Offers

LEXINGTON, KY.

Greatest Magazine Bargains Ever Offered

RECREATION - - 1 year, \$1.00 } All Three  
 REVIEW OF REVIEWS " 2.50 } One Full Year  
 Outing or World's Work may be substituted } **\$3.00**  
 SUCCESS - - - 1 year, \$1.00 } Checks accepted.

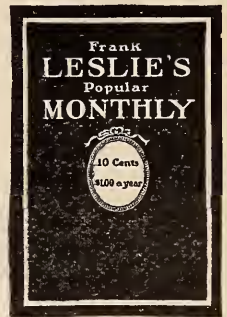

The periodicals in **any** club offer will be sent to one or different addresses. Join with your friends and take all. The subscriptions may be new or renewals. **All Subscriptions are for One Full year.**

	Regular Price	Our Club Price
Recreation and The Housekeeper	\$1.60	\$1.25
Recreation, Cosmopolitan and Pearson's (or Leslie's Mo.)	3.00	2.00
Recreation, Outing, Success and Outdoor Life	5.00	3.50
Recreation, Success, Leslie's Monthly and Pearson's	4.00	2.50
Recreation, Woman's Home Companion and Cosmopolitan (or Leslie's)	3.00	2.00
Recreation, Success and World's Work (or Country Life)	5.00	3.00
Recreation, Forest and Stream, (new Sub.) and Leslie's Monthly (or Cosmopolitan)	6.00	4.75
Recreation, Physical Culture, Cosmopolitan and Leslie's Mo.	4.00	2.50
Recreation, House Beautiful, Outing and Success	7.00	3.50
Recreation, Country Life in America and Cosmopolitan (or Leslie's)	5.00	3.25

Recreation . . . 1 year, \$1.00	Our Club Price	<b>\$4.50</b>
Review of Reviews " 2.50		
Outing . . . " 3.00		
Success . . . " 1.00		

Recreation . . . 1 year, \$1.00	Our Club Price	<b>\$4.25</b>
World's Work (or Country Life) " 3.00		
Lippincott's Magazine " 2.50		

Recreation . . . 1 year, \$1.00	Our Club Price	<b>\$2.50</b>
Outdoor Life . . . " 1.00		
Cosmopolitan . . . " 1.00		
Pearson's (or Leslie's) " 1.00		

Recreation . . . 1 year, \$1.00	Our Club Price	<b>\$3.50</b>
Physical Culture " 1.00		
Success . . . " 1.00		
Outing . . . " 3.00		

Recreation . . . 1 year, \$1.00	Our Club Price	<b>\$5.25</b>
Forest and Stream (new sub.) " 4.00		
Pearson's . . . " 1.00		
Outdoor Life . . . " 1.00		

Recreation . . . 1 year, \$1.00	Our Club Price	<b>\$3.25</b>
Photo Era . . . " 2.50		
Leslie's (or Cosmopolitan) " 1.00		
The Housekeeper " .60		

Recreation . . . 1 year, \$1.00	Our Club Price	<b>\$4.25</b>
Scribner's Magazine " 3.00		
Outdoor Life . . . " 1.00		

Recreation . . . 1 year, \$1.00	Our Club Price	<b>\$4.00</b>
St. Nicholas . . . " 3.00		
Leslie's (or Cosmop'n) " 1.00		

Recreation . . . 1 year, \$1.00	Our Club Price	<b>\$4.50</b>
Century Magazine " 4.00		

Recreation . . . 1 year, \$1.00	Our Club Price	<b>\$3.25</b>
Cosmop'n (or Leslie's) " 1.00		
Outing . . . " 3.00		

Ladies' Home Journal and Saturday Evening Post . . . Special Price **\$2.25**

**FREE** If you will send us **three** orders for **any** combinations you may have **free** as your premium a yearly subscription to **Recreation, or Leslie's, Mo. or Cosmopolitan.** Your own club and **two** other clubs make the **three.**

Youth's Companion (including all extra numbers and calendar for 1904) may be added for \$1.75  
 Harper's Magazine (or Weekly) \$3.35; Century, \$3.65; St. Nicholas, \$2.65;  
 Scribner's \$2.85; McClure's \$1.00; Munsey's \$1.00; Everybody's \$1.00;  
 Delineator \$1.00; American Inventor \$1.35.

**Club Raisers and Agents Wanted** to take orders for our combination offers, Liberal commission paid. Our large 44-page catalogue contains about 3,000 publications at low prices. Write for it now and see how much you can save. **IT'S FREE.**

Address **J. M. HANSON** MAGAZINE AGENCY 120 HANSON BLOCK **LEXINGTON, KY.**

# Camping Out

Camping may be pleasant, or disagreeable or dangerous. The equipment has much to do with it. Expense may be large and results unsatisfactory, or small with good results. The "KNOW-HOW"—what to take, what to leave—has most to do in insuring the comfort, pleasure and safety of an outing expedition, be it to explore untraveled mountains, or to find the north pole, or just to spend a month in the woods.

Our business is to "KNOW-HOW." Our success leads us to believe that we have learned our business.

We manufacture and sell everything for outfitting camping parties. Let us send our Catalogue R, or better still, call on us, if you contemplate "smelling burning wood" before an open tent in the shadow of the woods.

## **ABERCROMBIE & FITCH**

314-316 Broadway, New York

# ANOTHER GREAT OFFER TO AMATEUR PHOTOGRAPHERS

A 4 X 5 SERIES 1 KORONA CAMERA  
LISTED AT \$12.50, FOR 8 YEARLY SUBSCRIPTIONS TO *RECREATION*;

A 5 X 7 SERIES 1 KORONA CAMERA  
LISTED AT \$18, FOR 12 YEARLY SUBSCRIPTIONS;

A 4 X 5 SERIES 2 KORONA CAMERA  
LISTED AT \$18.50, FOR 14 YEARLY SUBSCRIPTIONS;

A 4 X 5 SERIES 3 KORONA CAMERA  
LISTED AT \$21, FOR 18 YEARLY SUBSCRIPTIONS;

A 4 X 5 SERIES 4 KORONA CAMERA  
LISTED AT \$25, FOR 20 YEARLY SUBSCRIPTIONS;

A 4 X 5 SERIES 5 KORONA CAMERA  
LISTED AT \$36, FOR 30 YEARLY SUBSCRIPTIONS.

*SAMPLE COPIES, FOR USE IN CANVASSING,  
FURNISHED FREE*

A D D R E S S

R E C R E A T I O N

23 WEST 24TH STREET, NEW YORK CITY



THE  
WORLD'S  
STANDARD



THEY'RE MADE TO MEASURE

# Putman Boots.

Go on like a glove *and* fit all over.

For a **Quarter of a Century** Putman Boots have been the Standard among Western Hunters, Prospectors, Ranchmen and Engineers (who demand the best) and we have learned through our personal contact with them **how** to make a perfect boot.

Putman Boots are in use in nearly every civilized country in the World. They are Genuine Hand Sewed, Water proof, Made to measure, Delivery charges prepaid, and cost no more than others. Send for Catalogue of over **30 different styles** of boots. Also **Indian Tanned Moosehide Moccasins**. We send with catalogue Order Blanks showing how to measure your foot.

We have in our files thousands of letters similar to the following.

**GENTLEMEN:**—Please send me another catalogue. We are all wearing Putman Boots and find them far superior to any other boot. I have ordered about 20 pairs for friends here during the past three years, and every pair has given perfect satisfaction, and I feel that I have done a man a favor when I have recommended your goods to him. Respectfully,

W. H. FLUKER, Gen. Mgr,  
(Columbia Mining Co.)  
Tatham, Ga.

**GENTLEMEN:**—I have just returned from a duck hunt in Colleton Co. this state, and though I tramped through the marshes for six days and a part of the nights, sinking in mud and water nearly to the tops of the shoes I got from you, my feet kept dry throughout the trip and the shoes were as soft at the wind-up as at the beginning. I can cheerfully recommend your shoes to all sportsmen. Yours respectfully,

C. F. DILL,  
Greenville, S. C.

**GENTLEMEN:**—Was fishing through the ice on the Flathead River this week standing for hours in wet snow and slush and tramping through the mountains, and I found the boots you built for me in December to be thoroughly water and snow proof, and quite warm. Yours truly,

L. R. FOGLE, Great falls, Mont.

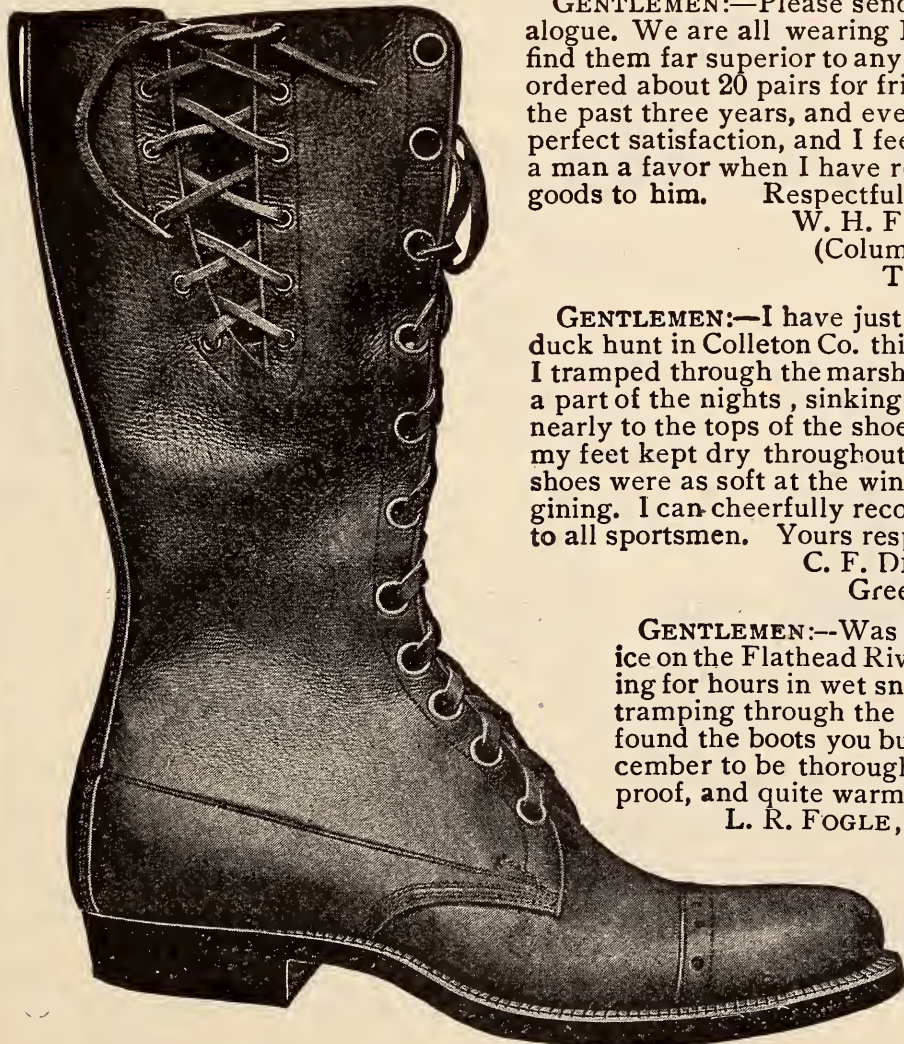

Illustration shows  
No. 900, 14 inch  
Boot, made to measure  
and delivered  
in U. S. for

**\$7.50.**

**H. J. PUTMAN & CO.,**

36 HENNEPIN  
AVE.

**Minneapolis. Minn.**

# Here Is What You Are Looking For.

And an Ever Ready Electric Lamp will enable you to find many other things that you will have occasion to look for in future.

**The Ever Ready Pocket Flash Light** is not only a luxury but necessity to every

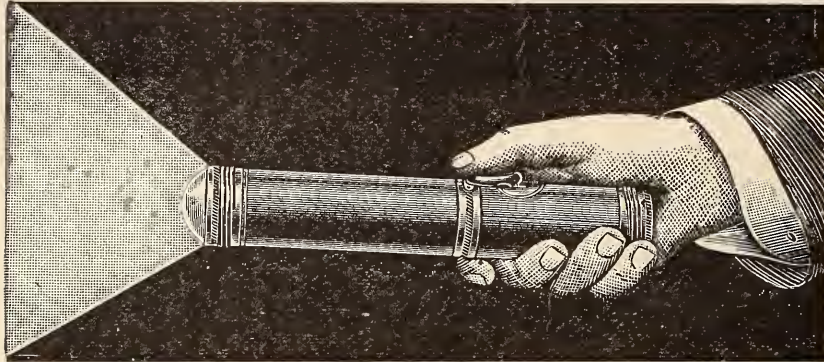

No Wires No Chemicals No Oil, Smoke nor Odor No Danger

**SPORTSMAN**

**FARMER**

**PROSPECTOR**

**CIVIL ENGINEER**

**RANCHMAN**

or to any one else who camps out, or who lives in the country.

Invaluable for use about camp, the house, the barn, or in the woods. If you wake up in the night and want to know the time, press the button and look at your watch. If you want to go into the barn at night to look after your horses, or anything else, **The Pocket Flash Light** will make the way clear, and is absolutely safe.

You would find a dozen uses for it if you had it.

Price complete, \$3. Extra battery (No. 10), 30 cents.

**The Ever Ready House Lamp** is a luxury for man, woman or child.

Thousands of houses have been burned, by persons getting up in the night, lighting matches, candles or lamps, and going about to find some needed article.

**The Ever Ready House Lamp** obviates all hunting for matches in the dark. It saves you from falling over the furniture in searching for the water pitcher, the other door, the match box, or whatever you may be seeking. You may safely carry **The Ever Ready House Lamp** into a cellar where naphtha or kerosene is leaking from a barrel.

Price complete, \$3.

Extra battery (No. 610) 30 cents. Extra bulb, 50c.

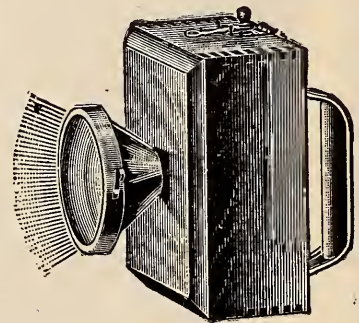

Fine Lens, Highly Polished Reflector, Finely Finished Nickel Trimmings.

**The Ever Ready Ruby Electric Lamp**

will save the eyes, the patience, and the conscience of any amateur

photographer, who may be fortunate enough to own one.

It is provided with patent catch, so that ruby glass slide can be raised and a strong white light can be had.

One turn of switch gives a pure Ruby light. Neat in shape and built on solid practical lines.

No more annoyance or foul smelling oil lamps, or greasy, unreliable candles. The Electric Dry Battery does the whole business. You take this lamp in your hand, turn the switch, go into your dark room, set down your lamp, and work comfortably, as long as you like. Then you turn the switch the other way, and that is all there is to it.

One dry battery will last you 3 months and costs only 30 cents.

Price of lamp complete, with one battery \$2.50.

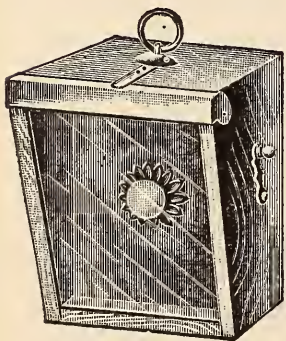

Remit by P. O. or Express Money Order.

**23 West 24th Street,**

**B. L. SCOTT  
NEW YORK.**

I refer, by permission, to the Editor of RECREATION.



# Ever been there Friend?



If so you know that you can't get through without an axe.

## Marble's Safety Pocket Axe

is the way out of difficulties.

Large enough to fell a tree, build a camp or quarter a deer. Small enough to go in the pocket. Send for Catalogue, A.

SOLD BY DEALERS OR DIRECT FROM THE  
**MARBLE SAFETY AXE CO.,**  
GLADSTONE, MICH.

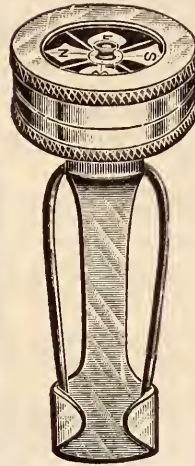

Cut  $\frac{3}{4}$  actual Size.

**W**ISE men don't go hunting, or fishing, or camping, or yachting, or prospecting, without a compass.

## MARBLE'S HANDY COMPASS

attaches to outside of coat or vest. Always in sight. Cannot be lost, cannot be demagnetized. Thoroughly reliable. Price with revolving card and jeweled needle, \$1.50. With plain jeweled needle, \$1.25.

Send for Catalogue, A  
FOR SALE BY DEALERS, OR  
**MARBLE SAFETY AXE CO.**  
GLADSTONE, MICH.

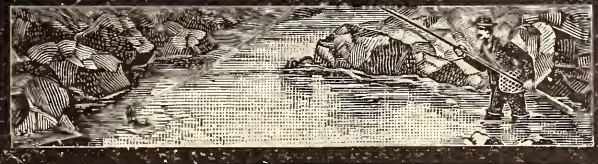

The Celebrated

# THOMPSON-QUIMBY

Hunting Boots, Shoes and Moccasins



All Work Guaranteed

THOMPSON

I have on file measurements of all who bought Boots and Shoes of the W. Fred Quimby Co., of New York for the past 20 years, and I make the same grade of sportsmen's footwear as they made. I was superintendent of the shoe department of that firm and bought the right to make these boots and shoes. Get a pair now. They will last years and are the cheapest in the end. I refer by permission to the Editor of RECREATION.

Measurement blanks and prices on application: Mention RECREATION.

**T. H. CUTHRIE**

33 William Street,

NEWARK, N. J.

"Nothing so Rare as Resting on Air."

## No Other Bed

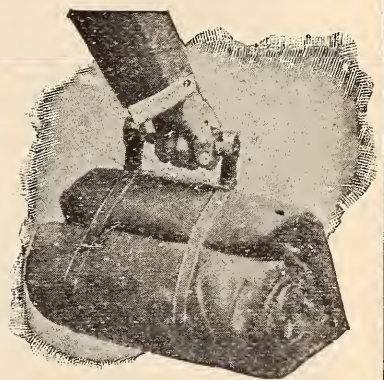

anywhere, at any price. can compare with the

DEFLATED AND ROLLED UP.

A mattress 75x25 in. makes a bundle 7x14 in. and weighs 10 lbs.

# Pneumatic Mattress

Most comfortable a man ever slept on. Lightest in existence. Strong, durable, guaranteed. At a fair price of all sporting goods dealers.

Pneumatic Mattress and Cushion Co.

2R. South St., New York City.

**"FOR 35 YEARS A STANDARD PIANO."**

# THE WING PIANO

**YOU NEED THIS BOOK** IF YOU INTEND TO BUY A PIANO. A book —not a catalogue— that gives you all the information possessed by experts. It makes the selection of a piano easy. If read carefully, it will make you a judge of tone, action, workmanship and finish; will tell you how to know good from bad. It describes the materials used; gives pictures of all the different parts, and tells how they should be made and put together. It is the only book of its kind ever published. It contains 116 large pages, and is named "**The Book of Complete Information About Pianos.**" We send it free to anyone wishing to buy a piano. Write for it.

**SAVE FROM \$100 TO \$200** We make the WING PIANO and sell it ourselves. It goes direct from our factory to your home. We do not employ any agents or salesmen. When you buy the WING PIANO you pay the actual cost of construction and our small wholesale profit. This profit is small because we sell thousands of pianos yearly. Most retail stores sell no more than twelve to twenty pianos yearly, and must charge from \$100 to \$200 profit on each. They can't help it.

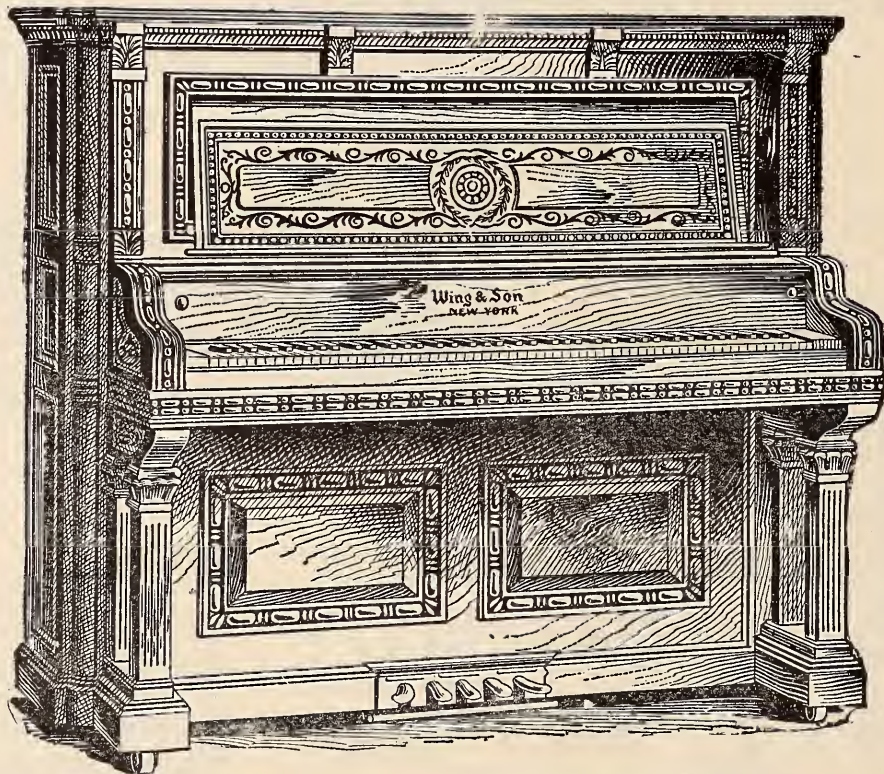

*A Wing style—45 other styles to select from.*

**SENT ON TRIAL** WE PAY FREIGHT. NO MONEY IN ADVANCE. We will send any WING PIANO to any part of the United States on trial. We pay freight in advance and do not ask for any advance payment or deposit. **If the piano is not satisfactory after twenty days' trial in your home, we take it back entirely at our expense.** You pay us nothing unless you keep the piano. There is absolutely no risk or expense to you.

Old instruments taken in exchange.

**EASY MONTHLY PAYMENTS.**

**INSTRUMENTAL ATTACHMENT** A special feature of the Wing Piano; it imitates perfectly the tones of the mandolin, guitar, harp, zither and banjo.

**IN 34 YEARS 33,000 PIANOS** We refer to over 33,000 satisfied purchasers in every part of the United States. WING PIANOS are guaranteed for twelve years against any defect in tone, action, workmanship or material.

**WING ORGANS** Are just as carefully made as Wing Pianos. They have a sweet, powerful, lasting tone, easy action, very handsome appearance, need no tuning. Wing Organs are sold direct from the factory, sent on trial; are sold on easy monthly payments. For catalogue and prices write to

**WING & SON,** 432 and 434 West 13th St.,  
NEW YORK,

1868—35th Year—1903.

Sent on Approval

TO RESPONSIBLE PEOPLE

# Laughlin

## Fountain Pen

Guaranteed Finest  
Grade 14k.  
SOLID GOLD PEN.

To test the merits of

### RECREATION

as an advertising medium  
we make this grand special  
offer, your choice of

These  
Two  
Popular  
Styles  
For Only **\$1.00**  
Postpaid  
to any  
Address

(By Registered mail 8 cents extra)

Holder is made of finest  
quality hard rubber, in four  
simple parts, fitted with  
very highest grade, large  
size 14k, gold pen, any flex-  
ibility desired—in feeding  
device perfect.

Either Style—**RICHLY  
GOLD MOUNTED** for pre-  
sentation purposes, \$1.00  
extra.

### Grand Special Offer

You may try the pen a  
week; if you do not find it  
as represented, fully as  
fine a value as you can  
secure for three times the  
price in any other makes,  
if not satisfactory in every  
respect, return it and we  
will promptly refund your  
money.

Illustration on left is full  
size of Ladies' style; on  
right, Gentlemen's style.

Lay this **RECREATION** Down  
and Write **NOW**.

Safety Pocket Pen Hold-  
er sent free of charge with  
each Pen.

ADDRESS :

## Laughlin Mfg. Co.

424 Griswold St., DETROIT, MICH.



## Indians of the Southwest

Where they live and how to get there—their homes,  
handicraft and ceremonies—an intensely interesting  
book of more than two hundred pages—written by  
Geo. A. Dorsey, Ph.D., Curator of Anthropology,  
Field Columbian Museum, an authority on the  
“Amerind”—profusely illustrated with half-tones  
from special photos—handsome cover in colors—sent  
anywhere on receipt of fifty cents—valuable for  
schoolroom or library. Address General Passenger  
Office, A. T. & S. F. Ry. Co., Chicago.

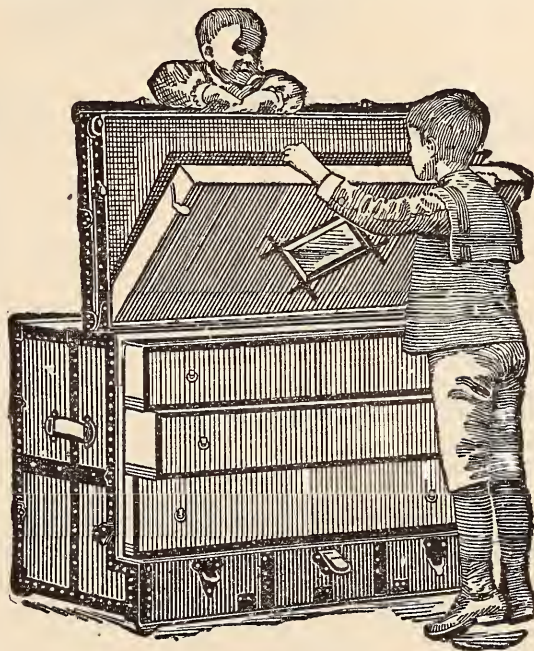

## Stallman's Dresser Trunk

Have you seen one? It is  
up-to-date. Think of it,  
everything within reach. No

heavy trays, but light, smooth  
drawers. Holds as much and costs  
no more than a good box trunk.

Hand riveted, almost indestructible.  
Once tried, always recommended.

Sent C. O. D., privilege examination.  
cc. stamp for catalogue. Mention **RECREATION**.

F. A. STALLMAN,

87 W. Spring St.,

Columbus, O.

# HAYNER WHISKEY

We are willing to lose money to get you to try **HAYNER WHISKEY**, for we know if you only try it you will always buy it, just as our half-a-million satisfied customers are now doing. Remember, we have one of the largest distilleries in the world. We are the largest bottlers of whiskey in the world. We have more whiskey in our eight Bonded Warehouses than any other distiller in the world. There is more **HAYNER WHISKEY** sold than any other brand of whiskey in the world. We have been in business over 37 years and have a capital of \$500,000.00 paid in full, so you run no risk when you deal with us. Your money back at once if you are not satisfied. Don't forget that **HAYNER WHISKEY** goes direct from our own distillery to **YOU**, with all its original strength, richness and flavor, thus assuring you of perfect purity and saving you the enormous profits of the dealers. You cannot buy anything purer, better or more satisfactory than **HAYNER WHISKEY** no matter how much you pay. Don't forget that a **HAYNER** quart is an honest quart of 32 ounces, 4 to the gallon. All other high grade whiskies are sold in so-called "quart" bottles that require 5 to the gallon. We give you one fourth more whiskey in every bottle, really reducing our price just that much. We give you both **QUALITY** and **QUANTITY**. There is nothing cheap about **HAYNER WHISKEY** except the price.

**1 QUART \$1.00**

**4 QUARTS \$3.20**

**WE PAY EXPRESS CHARGES IN EITHER CASE.**

Send us \$1.00 for **ONE QUART** or \$3.20 for **FOUR QUARTS** of **HAYNER SEVEN-YEAR-OLD RYE**, and we will ship in a plain sealed package, with no marks to even suggest contents. We will pay the express charges. When the whiskey reaches your home, try it, sample it thoroughly. Then, if you don't find it all right, perfectly satisfactory in every way and better than you ever had before or can buy from anybody else **AT ANY PRICE**, ship it back to us at our expense and your money will be promptly refunded. Isn't that fair? We stand all the expense if you don't wish to keep the whiskey. **YOU** risk nothing. We ship one quart on your first or trial order only. All subsequent orders must be for at least 4 quarts at 80 cents a quart. The packing and express charges are almost as much on one quart as on four and even at \$1.00 for one quart we lose money, but we want you to try it. **WE PREFER TO HAVE YOU ORDER FOUR QUARTS FOR \$3.20 RIGHT NOW FOR THEN WE WILL MAKE A LITTLE PROFIT AND YOU WILL ALSO SAVE MONEY.** But take your choice. \$1.00 for 1 quart or \$3.20 for 4 quarts, express prepaid. Your money back if you're not satisfied. Write our nearest office **TO-DAY**.

Trial orders for Ariz., Cal., Col., Idaho, Mont., Nev., N. Mex., Ore., Utah, Wash., or Wyo., must be 1 Quart for \$1.25 by **EXPRESS PREPAID**. Subsequent orders on the basis of 4 QUARTS for \$4.00 by **EXPRESS PREPAID** or 20 Quarts for \$16.00 by **FREIGHT PREPAID**.

ESTABLISHED  
1866.

**THE HAYNER DISTILLING COMPANY,**

DISTILLERY  
TROY, OHIO.

DAYTON, OHIO.

ST. LOUIS, MO.,

ST. PAUL, MINN.,

ATLANTA, GA.,







DOWN OVER THE OLD BUENA VISTA TRAIL CAME A LONE HORSEMAN.

# RECREATION

Volume XIX.

NOVEMBER, 1903

Number 5.

G. O. SHIELDS, (COQUINA) Editor and Manager

## THE MYSTERY OF STIRRUP RANCH.

H. N. BEECHER.

Who he was, where he came from, or where they went we never found out. Probably we never shall know until, perhaps, when the last big roundup comes off; when we are all driven into the big corral and the angel Gabriel swings his lariat by the golden gate and St. Peter keeps tally while they separate the mavericks and outlaws and drive the regular herd over on the South hillside where the feed is always good, the storms never come and the springs never dry up.

We found him alone at the ranch on our return from a day's ride on the spring roundup. He was a likely little cuss about 12 or 13 years old and all we found out about him had to be guesswork, for he would not tell us a thing. To all our questions he answered only,

"I promised Dad I would not tell"; and that Dad would come for him some time.

We found tracks of 2 horses, coming in from the East and going out over the Buena Vista trail. That was all. Of course we could not shake the kid. There was no choice but to keep him. He had not been with us 2 hours till he seemed as much at home on the ranch as the oldest of us. After supper we made him a little bunk in the corner of the big fireplace and put him to bed, where he was soon sleeping peacefully. Then we put our wits together to untangle the mystery.

We left it to Johnny to decide, when he should come. He had traveled more than the rest of us, having come from Maine to Colorado on a

box car without any pass from the railroad company. Johnny accepted the honor. He said that as nearly as he could judge the boy looked too honest for New York, was too swift for Philadelphia, his feet were too small for Chicago; but from the way he kept his mouth shut and minded his own business, he reckoned the little devil came from Denver.

Leige, who was our best judge of stock, said the little critter looked to him like a cross between an honest man and a city gal. We were satisfied to leave it so.

Of course we had to call him something and we left the name to Andy.

He kicked. Said he did not mind branding his own stock, but when it came to the maverick business he was not in it; so we called the little chap The Maverick and cut it down to Mave.

He had not been with us a week till we were all stuck on the little cuss. He took to our life like a half starved steer to a hay stack. He rode with us on the range, did odd jobs about the ranch and rode alone to the post office, 25 miles away, for our mail once a week. He did not seem to know what fear meant. He thought it was a picnic the day we rode up to the carcass of a Mexican who had been shot for stealing cattle, but the next day he sat down and cried by the body of a young colt that had been killed by mountain lions.

Once in a while Mave would wonder if Dad would come soon; but we never got a word out of him about Dad and we soon quit trying.

Everything went well all summer but after a while, when the leaves on the quaking asp began to turn yellow, when the grouse took to the high timbers, when coyotes howled louder and closer to the ranch, the cattle came down from the Gowell hills and we could see old Mose and his family of cubs tracking over from Black mountain to the Burrows hills; then we knew winter was coming. Mave knew it too and Dad had not come yet. Then the boy changed. We would hear him moan in his sleep and ask for Dad; and all day he would go about the ranch with scarcely a word to say. He was pining away for his father to come for him. Then he became sick. Of course we were not slow in getting a doctor, though it meant a 40 mile ride to Canyon City. The doctor staid all day and one night, watching by the little fellow, but told us it was useless; the boy was dying to see his Dad. If we could fetch Dad all right; if not, the doctor just coughed and rode away, for he knew we were mighty fond of the boy.

Blue days those were for us and we could not do a thing but wait. If we had known Dad's name or anything about him we should have had something to work on; but as it was we might as well have hunted for a rattlesnake above timber line.

Then it snowed, not much at first, nor hard. Each morning old Sangre de Cristo looked whiter than the day before; the big cuts and rough sides of the hills grew smoother and whiter. We knew if Dad did not come soon he could not get over the pass till the next spring.

We took turns watching, but one night Mave was so bad we all staid up. It was my turn to watch. I was close by the bunk and could hear him moan and call for Dad. I knew something had to be done soon, but what? I put my head down in my hand and tried to think, but, strange as it may seem, I fell asleep; and I dreamed; not a common, every night dream, but

one of those that only come to us once or twice in a lifetime and that we never forget. I was a boy again, back in the States, on the old farm at home. It was evening and I was sitting in the corner by the big fireplace. The old tabby cat was asleep at my feet. Pa was reading a New York paper, while Ma was going about doing up the supper dishes and putting things in order for the night. Then she drew her chair up beside me and Pa put aside his paper, took from the table the big Old Book and read. I can't remember all he read for he skipped about from one place to another, but I caught something about sparrows not falling to the ground without His notice; then he added: "Yea, though I walk through the valley of the shadow of death I will fear no evil for Thou art with me."

Then they knelt down, but I did not stay for prayer. I had business at the Stirrup ranch. Back through space I was carried by that mysterious something which none of us understands; back from my boyhood home, Ohio, to the mountains of Colorado, and I awoke!

The boys were standing around the little bunk. No one said a word, but I just got down on my knees and prayed. Guess it was the first prayer the old cabin ever heard. What I said I wouldn't tell you if I could, but I didn't waste any time telling the Lord what an unworthy bunch of critters we were at the Stirrup ranch. He knew that already. I didn't pray for the heathen in China, the nigger in Africa or the President and Senate of the United States, though I reckon they all needed it bad enough. I just kept in mind what I had heard in my dream. I figured if He was keeping tally on sparrows falling to the ground He wouldn't go back on poor little Mave, if we came to Him in the right way, and that's what I tried to do, for I knew we were in the valley of the shadow of death, or, as it seemed to me, in a great, deep cañon,



on a strange trail, with a big storm raging on top of the range. I didn't wave my hands and holler. I didn't swing my quirt and sock in the spurs. It isn't always safe on a strange trail, and praying was surely a new route to me. I just settled down easy like in the saddle, tightened up a little on the reins, drew in my knees a bit and started out with long, easy strides, for I didn't know how far I'd have to go.

I guess my message reached headquarters on time, for the next morning at sunup, just as the first rays were creeping over the tops of the

long hay ricks, and tipping 100 or more pairs of long horns in the big feeding corral, down over the old Buena Vista trail, riding one and leading another sorry looking broncho, came a lone horseman. Tired and worn out, he dropped the reins at the cabin door and walked in. Not a word was spoken, but we pointed to the corner where the sick boy lay. Then a faint voice whispered "Dad," as the stranger buried his face in the pillow beside his boy.

I had ridden the "Valley of Death" over the Gospel trail without losing a shoe.



LITTLE JACK.

AMATEUR PHOTO BY GUY V. BURKE.

Winner of 26th prize in RECREATION'S 7th Annual Photo Competition.

"If you find it impossible to keep open your line of retreat," said the instructor in the military school, "what ought you to do?"

"Open up a line of advance," was the prompt reply.—Chicago Post.



FROM A GUMBO BANK 8 FOOT IN HEIGHT.  
TO THE WATER SHE SPLIT THE AIR.

## TEX.

J. H. SMITH.

"Your hoss your pard," says the cowboy  
code,  
And Tex, of Big Antelope creek,  
Would wager his pile on a hoss he rode  
Tho' the hoss couldn't run a lick.

"Your hoss your pard," is a fair decree,  
And in that we will all concur;  
Yet Tex was evidence that idee  
Kin be kerried a lot too fur.

He went back East for a wife, you know,  
And brought a bay filly instead.  
"Couldn't fetch both; didn't have the  
dough,  
So I sure took the colt," he said.

She could sliver the record on demand,  
That mare o' his hadn't a match;  
You bet she peppered the clouds with  
sand  
Sure as ever she left the scratch.

She ranged the creek with the saddle herd  
Across from his shack one fall.  
A puncher is mostly a keerless bird,  
And Tex, he was worst of 'em all.

For with grazing stock about them days,  
It was frequently on the bills,  
For the Sioux to mix 'em in a haze  
And go foggin' among the hills.

On a sudden they hit the Big Antelope,  
Tho' we didn't expect 'em there;  
So I got the broncs off the picket rope,  
There bein' no time to spare.

Tex jumped the canoe and fanned her  
away  
In the face o' that howling pack;  
He'd fastened his eye on his little bay,  
Couldn't nobody call him back.

The saddle bunch flashed at the Injuns'  
squall,  
Sure to go buckwild at that;  
But the mare come quick at her owner's  
call  
More than half way down the flat.

His hand in her mane and like a shot  
She was off e'er he lit astride;  
The red devils' guns were crackin' hot  
As she peeled for the other side.

From a gumbo bank 8 foot in height,  
To the water she split the air—  
No angel flyin's a purtier sight—  
Till the spray concealed the pair.

The mare showed first, then her rider's  
head,  
His face lookin' pale and strange.  
I saveyed at once the Indian's lead  
Was takin' him over the range.

He hung to her tail till she swam across,  
And says he with his eyes ablurr,  
"Man might do worse 'n die fur his hoss;  
Anyways fur a hoss like her."

---

Weary Wraggles—Hey! You won't git  
nothin' decent in dere. Dem people is vege-  
tarians.

Hungry Hank—Is dat right?

Weary Wraggles—Yes, an' dey got a dog  
w'at ain't.—Philadelphia Press.



HE THINKS HE SEES SOMETHING.

AMATEUR PHOTO BY S. N. LEEK.



A PAIR OF LOCKED ELK HORNS.

AMATEUR PHOTO BY S. N. LEEK.

## ELK IN WYOMING.

S. N. LEEK.

September 12th we left the settlement, with saddle and pack horses, provisions, tents, bedding, and everything necessary for a month's sport in the mountains. We reached camp early in the evening, put things in good shape and started the next morning for a hunt. We had gone some distance and were sitting on the apex of a hill overlooking a large tract of heavy, half burned

looked sharply ahead. We could see something moving in the brush, but we looked in vain for horns.

"A cow," said the guide, "scarcely 25 yards away"; and to tantalize us the old bull whistled, apparently but 25 yards farther. We saw another cow, then another. The woods seemed full of them. I was tired standing in one position so long and quietly shifted a little. An old



A BUNCH OF ELK.

AMATEUR PHOTO BY S. N. LEEK.

timber, when we heard a long, shrill whistle, or bugle, about half a mile away in the timber. It was the old bull's challenge. In a few minutes we heard it again, from the same direction. Hurriedly tying our horses we took our rifles and started in that direction. Every few minutes we heard that shrill, sharp whistle. The wind was favorable. We worked cautiously ahead, and again we heard the bugle, scarcely 100 yards away, but the timber was so dense we could not see half that distance. Suddenly the guide stopped and

cow thought she saw something move and looked our way. We hardly dared to breathe. Look as we might we could not see the old bull. Another cow looked at us, turned slowly and moved off. Then they all went, with a great rattling of brush and snapping of sticks. We never even saw the bull; but better luck next time!

We walked slowly back to our horses, passing, on the way, through numerous small parks, or open places in the timber, where there was a rank growth of grass. We noticed it was trampled down by the

elk, and there were numerous beds all around where they had been lying. At that season elk will usually be found in bunches of 15 to 30 head; cows and calves, with a few 16 month old bulls and one big bull. There are some great fights, the winner always keeping the other old bulls out of the bunch. He also keeps the cows in a close bunch so they are easier to guard and to prevent from straying. Sometimes he has 3 or 4 bulls to guard against. They keep him on the go all the time. September 1st finds him a fat, sleek, beautiful animal. October 15th his fat has all disappeared, his horns are more or less broken and he is scratched all over from fighting, but as a general thing not enough to mar his beauty for a trophy. The flesh of the bull

elk, unlike that of most other male animals, is not strong at that season. About October 15th the bulls begin to leave the cows again and to get off in small bunches by themselves. When the first snows come, which may be about October 1st, the elk begin to work down toward their winter range; also to congregate into large bunches which in this country, by the time they reach the lower foothills, about December 1st, may number thousands in a single band. The bulls usually come down in advance of the cows, but nearly always by themselves. It is sometimes possible to see 50 old bulls together. When the elk get in their winter quarters they divide into smaller bunches and scatter over the range.

## DE HUNTAH'S JUBILEE.

FRED W. GOSHORN.

De 'possum time am creepin', creepin'  
ni'er;  
De pop-paws turnin' yaller on de tree;  
I' se haulin' in de wood fer wintah's fire  
An' 'parin' fer de ol' man's jubilee.  
O de rabbit an' de squirr'l,  
Am a-fat'nin' up fer me!  
An' de's nothin' in dis worl'  
Lek' de huntah's jubilee!

De summah long I'se sot dere on de bank,  
De same place, mine you, whar de young  
'ons pull  
De fishes by de score, but nary yank  
Fer me wo'th menchnin'; so I'se got my  
full.  
O de rabbit an' de squirr'l,  
Am a-fat'nin' up fer me!  
An' de's nothin' in dis worl'  
Lek' de huntah's jubilee!

De summah long dat dawg, de bes' you  
seen,  
Bin fightin' ob de flies an pesky fleas;  
But now, sah, he's a-gwine ter hunt me  
lean,  
Kase he know how de ol' man's heart ter  
please.  
O de rabbit an' de squirr'l,  
Am a-fat'nin' up fer me!  
An' de's nothin' in dis worl'  
Lek' de huntah's jubilee!

I wondah why de fros' don't hurry 'long?  
Et look ter me lek' time ter cut de cohn?  
I'se gwine ter git my senses mixed up wrong  
Ef time don't trabel fastah, sho's you  
bohn!  
No! de's nothin' in dis worl'  
Dat's a-satisfyin' me,  
Lek' de rabbit an' de squirr'l  
An' de huntah's jubilee!

The following obituary recently appeared in a Missouri paper:

"John Anderson, we are sorry to say, has decesed. He departed this last Munday, he went fourth without a strugel and such is life. He kept the grocer store at the Corners and his wife will still keep it. His virtues was numerus and his wife inherits them. We are happy to stait that he never chewed and was always a honorble man and his wife is also. His wife will keep the store jest like he did and will be pleased to see old customers at eny time."—Chicago Record-Herald.

## A TURKEY HUNT IN NEW MEXICO.

J. E. BECK.

A few days before Thanksgiving it was agreed that a ranchman, his son and I should meet at a place in the White Mountain district of New Mexico, some 15 miles from the fort, to have our first fall hunt. They were to take bedding in the wagon for me. I started about 1 o'clock in the afternoon, expecting to reach camp in time for supper, but a little too late to help

strange to me and I made no pretense of being a Pathfinder, my chances of sitting by a camp fire without gathering the wood myself were in the proportion of squirrels to mosquitoes on a hot day in an Alabama swamp.

After spending some time in adverse criticism of the human family in general and of ranchmen in particular, I decided



SLUNG HER ON A POLE AND STARTED FOR CAMP.

ANONYMOUS.

get in wood. I jogged along leisurely, fearing the penalty of getting to camp too early, and arrived at the rendezvous about 4.30. My feelings may be imagined when I found a message there telling me the other 2 had changed the original plan and were camped in a canyon 10 miles farther in the mountains. As the country was all

to chance finding the new camp and cool off *en route*, there being snow on the ground. The way that cayuse covered those 10 miles would have surprised any wayfarer who had seen his sleepy gait earlier in the day. There is no twilight in that section and from sundown it goes to pitch dark in about 20 minutes. That

time found me looking for a camp place; but fortune favoring me, I came around a little point almost on top of a ranch house. There they told me our camp was some distance up the next canyon, but intimated that for a certain token of appreciation I might stay with them over night. I "fell off," as they expressed it, and their hot biscuits, venison, gravy, butter, etc., disappeared, via my alimentary tract, like water in a gopher hole.

On finally reaching camp the next afternoon, having hunted on the way, I found the ranchman had killed 4 large turkeys. The next morning we took different ridges, the son and I each on horseback, while the ranchman said he preferred to walk. After riding about 2 miles, making as little noise as a drove of cattle in a field of dry corn, I jumped a deer some 150 yards ahead, and he disappeared over the ridge. Having been told by old timers that a deer will always stop to look at a man before departing, I conceived the idea that that deer would wish to get another look at me; so I calmly tied my broncho and slipped to where it seemed the buck should be waiting. I learned that deer in that locality have a perverse habit of following their inherited instincts in preference to the rules laid down for their guidance by old timers. For example, deer are not invariably found at the heads of canyons, or on the ridges, or at any other place at any particular time, day, season or year. Convenience to feeding ground, shelter from the elements and a place of comparative safety seem to be the only conditions influencing their habitat.

After a few philosophical reflections I decided to abandon that untutored, cloven footed beast. About a mile farther I was riding along in the same quiet manner when some 50 turkeys strolled up a small canyon 200 yards ahead. They disappeared before I had time to get down, but leaving my horse I followed the direction they took and finally met the ranchman's son. We separated and I took the side hill; and as standing was easier than walking I stopped. I had only been still about 2 minutes when something came sneaking close to the ground, and getting my 25-35 ready, I waited. A turkey came through an opening on a dead run, at a distance of about 25 yards, and I turned her over, barely breaking her back. I slung her on a pole, passed my gun over to the boy and started for camp at once.

The next day we hunted in the forenoon without success and at 2 p. m. I started from the ranch house, after bestowing the expected token, on a 25 mile return ride, leaving the turkey to be brought in the wagon. My friend sent it to me a few days later, and we boys had a feast Thanksgiving day; but my position can be appreciated when I tell you that one of the heathens found several Number 4 shot in the bird. They knew I had used a rifle, as I had not been too modest to brag about killing the turkey on the run with it. The ranchman had used a shot gun and had exchanged game with me. Of the 8 turkeys and one deer we 3 got on that trip, the ranchman killed 6 turkeys and the deer. We attributed his success to the fact that he walked instead of riding.

---

## SEPTEMBER.

C. C. HASKINS.

(With apologies to L. C. Elerick.)

There's a cold, nasty wind from the Sou-  
southeast,

And the wind is a howling gale,  
That neither is good for a man nor a beast  
And its song is a mournful wail.

The walks are all covered with mud and  
with leaves,

And the grasses are slipp'ry and brown.  
The sun hides his face; ah! he inwardly  
grieves

That the furies are painting the town.

The flowers are withered, the dead buds  
decay,

The Frost King his anger has shown.  
The coal pile is certainly melting away,  
The bright birds of summer have flown.

The sky is o'ercast, and the black rolling  
clouds

Are scurrying, restless and free;  
They're hastening on with the rallying  
crowds,

To join the equinox spree.



## A TURKEY HUNT OF LONG AGO.

M. B.

As soon as I was old enough to ride a horse, father began taking me with him on his hunting trips. A sheepskin was used for a saddle blanket and I sat behind, hanging to father's coat tails when the riding was rough. My shooting experience began when I got strong enough to stand the kick of a gun and this incident took place shortly after that time.

I well remember a trip we had one Saturday in November and the luck, and lack of it, that attended. A darkey reported that a gang of turkeys was ranging on a creek about 5 miles from home. Father decided

Soon the turkey took fright and flew out. Father tried a difficult shot and missed. I was so small I don't suppose the turkey considered me dangerous; anyway, she came sailing over me, appearing as big as an ostrich to my excited eyes. I hazily remember looking along the barrel and pulling trigger; then there was a crash and the turkey fell in the bushes in front of me, surprising me so that I jumped.

We walked around the woods until we had the gang well scattered, then separated to make our blinds, father taking the dogs with him.



A BIG FAT TURKEY THAT HAD GONE TO REST IN A SMALL TREE.

to go after them, and, better still, to take me.

We started as soon as breakfast was over, I riding behind him as usual. He took along both of the dogs, one a young Gordon setter, high mettled and excitable. When we reached the hunting grounds the dogs disappeared in the woods. While the old horse was making her way carefully down a steep ridge they began barking, and a moment later we heard the "putting" of turkeys and the swish of wings.

One bird sailed into a big pine about 100 yards ahead of us. Father dismounted, tied the horse to a tree, and motioned me to follow him. Instead of following, however, I branched off to the right and with gun cocked crept up behind the cover of a clump of sassafras bushes.

They tell a story of an old turkey hunter in our county. His front name was Putnam, cut down by common usage to Put. One day he flushed a gang of turkeys, made a blind and began calling. Then he fell asleep. An old gobbler strolled up and looked in. As he did so, Put snored, at which the gobbler cried in alarm, "Put-put-put!" It awakened the sleeper, who, as the turkey disappeared answered, "Hello, what you want?"

Something like this came near happening to me on this occasion. I had been calling some time and as no response came I stretched out on my back to take a little rest. I don't know whether I went to sleep or not. At any rate, the next thing I remember was a frightened gobble, and looking up I espied a turkey about 15 feet

away, but rapidly making it more. Snatching up the gun I poured 2 ounces of lead into an inoffensive tree, then stared while the turkey sailed gracefully away.

I was fully awake then and yelped 10 times as much as was necessary, to make up for lost time. Then father's gun rang out, followed by the whiffing of a big bird through the air above me. It was a turkey and he passed within range, but he was going so fast I didn't have the presumption to shoot.

The next noise to disturb the quiet was the mournful howling of the young setter. Then father came down to my blind, a disgusted look on his face, the dogs following dejectedly behind him. It seems he had a turkey coming, when the pup saw it, jumped out of the blind and chased it away. Father gave him a lesson in be-

havior, received vociferously enough to scare everything out of the woods.

When we went to get the horse we found the bridle hanging to the tree all right, but the other end was empty. The old horse had slipped the headstall and departed. It was getting late, so we didn't attempt to track her up. Father said she would come home all right, if she wasn't already there; so he shouldered the bridle and the turkey and led off, while I trotted on behind. We had not gone far when we spied a big fat turkey that had gone to rest in a small tree. Father gathered her in and we hit the road once more.

Home seemed eternally far off, but we got there at last. The old horse hadn't arrived. A neighbor rode her in next morning, having found her the evening before making love to his fodder stacks.



AMATEUR PHOTO BY F. A. BURR.

PREPARING SUPPER.

Winner of 29th Prize in RECREATION'S 7th Annual Photo Competition.

Blohart—Yes, I once thought of going on the stage, but friends dissuaded me.

Knocker—Friends of the stage, I presume.—Baltimore American.

## OUR HUNT AT FENCE LAKE, MICH.

JOE A. BOTTKOL.

Early on the morning of November 4th, '02, we boarded the St. Paul passenger train, our destination being Floodwood. We were going on our annual deer hunt, 5 of us besides Bill, the cook. At 9.30 o'clock we arrived at Floodwood, loaded our camp outfit and grub chests into a wagon, shouldered our guns, and tramped 9 miles to Fence Lake. There we made camp.

The next day we started out to hunt. I went East, in the maples, armed with a 30-30 Winchester fitted with Lyman sights, and a  $3\frac{1}{4} \times 4\frac{1}{4}$  pocket Poco. It was a crisp, exhilarating morning, with frost glistening on the autumn leaves. Occasionally the hoarse note of a raven broke the stillness of the forest; while red squirrels scolded and barked at me for trespassing on their grounds. I finally came out in an old chopping where I found Charles. We decided to cross the chopping, and mount a high hill, from which we could get a good view of the surrounding country. We had been there only a short time when I spied a buck running in a slash, about  $\frac{1}{4}$  of a mile away. He evidently had seen us, as he was making for a small swamp, or pocket, clearing the windfalls with graceful ease, carrying a magnificent set of white antlers, well back over his shoulders. As he neared the swamp he disappeared. Charles waited 20 minutes while I made a detour to the other side of the swamp. At the end of that time Charles started for the swamp, intending to go through it, and drive the deer in my direction. When about 70 paces from the edge of the swamp he heard the snapping of a twig, and got behind a stump. Presently the buck emerged from his retreat, walked about 10 yards, stopped, lowered his head and commenced prodding at something on the ground. Charles fired and the buck staggered and fell. A doe bounded up in his place, waved her flag, and tried to ascertain in which direction the danger lay, when another shot dropped her in her tracks. As both deer were struggling on the ground, Charles advanced a short distance and finished them. Immediately after, there was a loud crashing of brush in the swamp and coming directly toward him. The next instant a buck thrust his head through an opening of the cedar boughs. Charles fired, striking him on the nose. At this the buck leaped over a windfall and came at full speed toward him. Charles fired 3 more shots, one striking the buck on the left front leg. The magazine was then empty, and when the deer was only a few yards away Charles threw up both hands and yelled. At that the deer turned

his course to the left and went by. Charles slipped 2 more cartridges in the magazine. The buck in the meantime slowed down to a walk, and Charles dropped him at long range.

The following morning Math brought down a doe and a fawn in the same chopping.

The next morning Frank and Will went East, where Frank shot a buck with a set of large antlers. Bill, the cook, being relieved by Charles, went South in an old slash, and came back with a doe. Math and I crossed the lake in a boat and took an old logging road running through the maples, stopping now and then to listen. While thus engaged we heard a deer walking on our left. Math took up the trail and I ran down to where a runway crossed the road. It was a frosty morning, and I was soon shivering on my stand, until the sun appeared above the crest of a ridge, forcing comfortable warmth through the transparent tree tops.

I had quite forgotten about the deer, when I heard a rustling in the leaves and turning my head in that direction I saw a deer coming my way. I dared not move, for he would have heard the least sound. He came to a halt behind some brushes, I fired and all was quiet. I knew I had hit him, and I dashed into the brush, throwing a fresh cartridge in the chamber as I went. The buck bounded up some distance ahead of me, and ran broadside, his right hind leg dangling. I fired 3 more shots before he disappeared, one of them taking effect just below the back bone. I then took up the trail, Math joining me. In a short time we found the buck on a hillside, where I finished him with a shot through the neck. He was a 190 pounder.

The following day I jumped 2 deer, whereupon I gave my rifle some needed exercise. On returning to camp I found that Will and Frank had each shot a buck.

That night I awoke after midnight to find myself shivering. Math and Will, who slept on either side of me, were also shivering. Our fire had burned low and each of us was waiting for the other to get up and replenish it. Finally Math rose and soon our friendly little camp stove filled the tent with warmth. We used a camp stove manufactured by W. D. Cree, which is advertised in RECREATION. For baking and keeping fire it is the best thing we ever used.

A few days later Bill shot a buck. We then had 12 deer and were satisfied. The next day our team arrived, and with many regrets we broke camp,



THE WOUNDED CAVALIER.

# PICTURE MAKING WITH THE AID OF THE CAMERA.

K. ROWA.

Photos by Joseph T. Keiley.

Doubtless the majority of the readers of RECREATION are already aware that a photograph is not necessarily a picture, in the artistic conception of that word. A picture, roughly speaking, is a flat, or surface, representation of some scene, object or person so rendered as to concentrate the interest in a harmonious manner on the subject depicted, to the elimination of all unnecessary



SIoux CHIEF.



A CAVALIER.



BACCHANTE.

detail and the subordination of all accessory objects to the main theme treated. Just as all the details of a good story must lead up to its point, or climax, so must all the details of a picture subordinate themselves to and support the subject treated. For example, it would not be pictorially consistent in presenting the picture of a dead grizzly to set up a small cat rifle against a neighboring tree, as if it had been the weapon used in killing the bear. Everything else might be well presented, yet, to anyone familiar with hunting, the picture, instead of being a subject for serious consideration to

sportsmen, for whom such a theme is primarily intended, would be a source of amusement.

Again, if the picture be intended to represent a dead grizzly the gun should not be given the most conspicuous place, nor should the animal lie in such a position as to appear out of shape, or showing its form in such a manner as to be characterless and meaningless in its pictorial representation. Still again, there should not be a mass of other objects all equally distinct, pronounced lines running in divergent directions or the like. The first principle of pictorial composition, do not be frightened at the name, is orderly directness. Composition simply

means to tell in a pictorial way something that has been seen. It must be remembered that it is necessary to represent on a plane that which has 3 dimensions; next that the space in which to do it is limited to the size of the photographic plate; and, finally, that the object and its accessories must be so arranged as to make them fill the space most effectively. If you tried to picture in words what you are trying to delineate with your camera you would confine your attention to the main theme, to the exclusion of all unnecessary matter. Keep this rule in mind in making a picture and adhere to it as closely as possible.

---

## HUNTSMAN COME.

C. G. RIDEOUT.

Come, for the West winds are calling,  
The whispering pines all beseech you;  
The spirits of chase and of forest,  
Have sworn true allegiance to you.

Come where the grizzly is growling  
In challenge to huntsman and foe.  
Come drink from the cool, rippling waters  
That out of the mountains do flow.

Come where the antelope, feeding  
In freedom o'er valley and hill,  
Is fleet as the sunbeams of morning,  
That dance over mountain and rill.

Come where the scream of the panther,  
Borne down from the hills on the night,  
Mingles with dreams of the conflict  
And dies with the coming of light.

Come where both mountain and foothill,  
Both forest and valley, unite  
In welcome and honor to sportsmen,  
In homage to might that makes right.

Come for the West winds are calling  
To those who for freedom still yearn;  
Come list to the music of Nature,  
Where the camp fires of heroes still burn.



AMATEUR PHOTO BY SIMON C. SPEAR.

SHELLING CORN IN IOWA, FOR THE GAME AND FISH HOGS.

(See page 408.)

## IN THE UPPER PENINSULA.

A. B. RICHMOND.

Photos by the Author.

In the early morning of November 5th, Buckshot, Buckskin, Eagle Eye, Trail-maker and Tenderfoot met at the train that would start us on our journey for the extreme North of upper Michigan. About midday we picked up Baldy, and our party was complete. After an uneventful journey of 15 hours we arrived at Seney, our point of disembarkation. There we made arrangements for an early start, and with a sigh of relief we crept be-

west wind swept across the plains, rendering it necessary to keep moving in order to keep warm. About 2 p. m. we reached an old camp, 16 miles out, and building a fire we stopped to lunch and feed the horses.

After lunch we left the old road we had been following, and branched off on an unused logging road leading in a zigzag fashion around Driggs' lake to our camp. There we encountered our first real trouble



ROSS CREEK ABOVE THE DAM.

tween the coverlets of a good bed. At daybreak the morning of the 6th we were out and soon had our wagon loaded with all our camp equipage, groceries, etc., and with our jolly toteman, Louis Bras, we were at last started on our long journey of nearly 30 miles over barren pine plains, and through dense forests of hardwood timber. Owing to our heavy load we necessarily walked much of the distance, and it makes a long, tedious journey. Unless a person is injured to hard exercise, and thoroughly enjoys it, my advice to him is never to attempt the trip. A raw North-

in the shape of fallen timber, which obstructed our progress and had to be removed before we could continue. Each season we have to do this, as the road is used only by our party. We provide saws and axes, and taking turns we gradually get the fallen trees out of the way. Dusk found us at Driggs' dam, still 6 miles from our camp, but luck was with us, as the old dam and the bridge over the Driggs river, which we were afraid we should have to repair, were in good shape, having been repaired by a lumberman who had been getting out a few logs



THE WOOD BUTCHERS.

in that vicinity. After getting safely over, thanks to Louis, who is an excellent driver, we lighted our lanterns and continued our plod to camp, at which we arrived at 8 p. m., tired and hungry. The old hunter with whom we had left our camp had cleaned it, and the stoves were all ready for a fire. In less than an hour after our arrival we all enjoyed our first meal in camp. After supper we sought our comfortable bunks, well filled with clean straw and fragrant hemlock boughs, to dream of 3 long weeks of pleasure and sport before us.

Each man had his duty to perform in camp, and all did it well. Our first day in camp was spent by our wood butchers, Eagle Eye and Tenderfoot, in getting a supply of good wood, as our *chef*, Buckskin, is particular about the quality of the fuel. The *chef*, assisted by Baldy and Buckshot, soon put the shack in good running order, while Trailmaker, the water boy, fixed his landing at the lake and prepared his benches for the reception of his water pails. As dusk stole over the landscape, gradually obliterating the pleasant view from our windows, we lighted our lamps, and sitting around the warm fire in the cosy quarters of our cabin, we discussed the morrow. We found it hard to realize that we had been absent from the old shack 11 months. Although 20 miles from the nearest human habitation, we were surrounded with all the comforts of home, free from all trouble and care, only

on pleasure bent. Is it strange we were happy?

It is a rule of our camp that the first deer killed shall be used for camp purposes, so after a good breakfast the morning of the 8th, the opening of the season, we all started out, determined to bring in venison for the next meal. Each had a favorite spot to visit, and we approached it with much trepidation, expecting every



THE WATER BOY.



moment to see the white flag wave a quick goodbye. The day was a disappointment, however, to all except Buckskin, who was fortunate in securing a fawn, with a running shot. The deer was 2 miles from camp, and it took 3 of the party to drag it in; but the supper of roast venison and ruffed grouse repaid us all for our labor.

From the first day our larder was well supplied with choice venison and grouse. Sunday dawned warm and pleasant, and was spent in a quiet manner by all, Buckskin devoting a considerable portion of the day to making pictures in the vicinity of the camp.

All were out Monday morning early. The atmosphere was cool and bracing, but it was noisy traveling, and although many deer were seen by all, none was killed until late in the afternoon. Buckshot, our explorer, accompanied by Baldy, took a trip of investigation toward Creighton creek, 3 miles West. While they were making their way through a swamp, talking as earnestly as 2 school girls, a doe jumped into the old logging road right ahead of them. Remembering their early training they immediately turned their batteries loose. As soon as the fusillade began, deer appeared from all directions. The boys emptied their magazines, partially reloaded, and emptied again. Still the deer came. The boys thought they had run into all the deer in the Upper Peninsula. After the smoke of battle had cleared they went forward to view the scene of carnage, expecting, of course, that each had his limit and would have to take the next train home; but all they could find was a doe, killed by Baldy, who felt well satisfied. In relating their experience that evening they concluded they had seen 6 deer, although at the time they thought there were at least 100.

The weather continued warm and pleasant, with no snow to gladden the hearts of the old hunters. In consequence still hunting was hard, but it was so delightful to wander through the grand old woods with the smell of the late autumn pervading everything, that we were more than compensated for the lack of snow. After we had been in camp about a week, one morning was ushered in with a quiet soft rain, an ideal day to still hunt. Everybody started out early, to make a record day, and when the returns came in at night it proved to be the best in camp.

Eagle Eye haunted The Loop, formed by some old logging roads North of the camp, all day, with no success until late in the afternoon, when he was fortunate in killing a 4 prong buck with a difficult running shot. Satisfied with his good luck he was walking rapidly toward

camp, when a large doe broke cover just ahead of him. He had no idea of hitting her, but thought he would "take a draw at her just for fun," and was much surprised to see her go crashing to the ground. He dressed her, unloaded his gun for fear he might kill more and went to camp.

Buckshot followed his old jumper road up toward Mud lane. While quietly standing under an old hemlock he was startled by a snort a little to his right, and turning quickly he saw a large buck plunge through the whips. Judging from the noise, the animal apparently stopped after running a short distance. Buckshot cut around where he thought the deer had stopped and approached the spot with the utmost caution. Not a sound did he hear nor a motion anywhere. After listening fully 10 minutes he mounted an old pine stump standing near, to get a more extended view. He had barely straightened up when suddenly, within 50 feet of him, the buck started down through the tall timber with a loud whistle, hitting the high places at every jump. Buckshot was so startled he almost fell off the stump, and for a moment forgot he had a gun; but gathering himself he began to empty his new Winchester. Judging from his description of the scene afterward he must have destroyed several acres of choice hardwood, but he was successful in ending the earthly career of a 3 prong buck, which satisfied him for the unseemly waste of ammunition.

That same day Buckskin visited his favorite hunting place, the hills, as he is fond of hard work and climbing. He had hunted diligently all the morning and had seen only a fawn, which he allowed to pass, as he was looking for larger game. About 11 o'clock he approached the brow of a hill overlooking a ravine running up from a swamp. Standing quietly a short time and scanning the valley beneath, his attention was attracted to a slight motion in the edge of the swamp. Carefully watching this particular place his patience was at last rewarded by seeing the monarch of the forest walk out and proudly make his way up the trail toward the high ground above. He was a magnificent animal with a grand sweep of antlers, 5 prongs on a side. The heart of Buckskin was immediately troubled with palpitation, but he was master of the situation, and could see plainly enough to pick out a good open space between the trees. When the deer appeared in this space a plaintive "Baa" caused the animal to stop like a graven image and look in the direction of the sound. Almost at the same instant the sharp whiplike crack of the 30-30 was heard. Without a struggle the lordly creature sank to his knees, fell forward,

swayed a moment and all was over. The deer was a large one and it was with some difficulty Buckskin finally succeeded in hanging him up. At the camp that evening, stories were told of the day's experiences, and with a total of 4 deer for the day's labor everybody was more than satisfied.

The days passed with varying success. The weather continued warm and pleasant, with no snow. In consequence we did little hunting, as it was apparently going to be a problem to keep our venison from spoiling. Many of these days were spent by the different members of the party in

inence overlooking the lake, and beheld the beautiful vista unfolded through the branches of the trees surrounding them. The hill was 500 or more feet above the lake, gradually descending over the velvet green of the tall hemlock and spruce trees, which apparently spread out like a huge green carpet until they at last met the white line of the pebbly beach.

We found several beaver families not far from our camp, and devoted much time to studying the ingenious construction of their dams. We took home a number of souvenirs, in the shape of chips and cuttings.

Buckshot secured a large buck with a



GETTING BREAKFAST.

exploring the surrounding territory. Many times some of the party were lost, but with the exception of Tenderfoot all were old woodsmen and used to such experiences; and although at times they were long after dark in reaching camp they ultimately succeeded in finding it, with no adventures worth mentioning, excepting once in a while a slight chill chasing up and down the spine, at the screech of a lynx in the trees overhead, or the distant and mournful howl of a wolf.

Trailmaker and Buckshot made a pilgrimage one day to the pictured rocks on the shores of Lake Superior, and although it was a 30 mile walk they were amply repaid for all weariness when they at last stood on the summit of the em-

freak set of horns. There was no regularity whatever to the antlers. They branched everywhere, and crossed one another in all directions. The horns had at least 16 points.

Trailmaker secured a large spike buck on the old logging railroad bed about 4 miles North of our camp. He got into a drove of 4 or 5, and after heating his gun red hot in the fusilade that followed, he found the buck in the woods about 10 rods from the railroad. We had 2 deer to draw in from that section, making nearly a 5 mile haul on bare ground.

Friday, November 28th, found us safe back at Seney again, from which point we separated, each to pick up anew the thread and routine of everyday life.

## BILL BROWN'S RETRIEVER.

PALMER C. GOBLE, JR.

Yes, she is a fine dog, a little lame in the front right foot, but not enough to disable her.

Retrieve?

Yes, a good retriever, barring that same front leg trouble.

Where did I get her?

From Bill Brown who used to live back on the Riverside road.

What did I pay?

Not a cent; a clean gift and as fine a bred spaniel as you ever saw.

I never told you how I got her, did I? I promised Bill I would never mention it to him or anyone else, but he's gone West and nobody can laugh loud enough for him to hear it in Oklahoma, so I'll tell you.

It was along in November that a cold spell set in and the wind blew up the lake until it was too rough for a bird to float on. One night I met Bill in the barber shop and he proposed that we go down the river at daybreak next morning to try for a few ducks. The river was about 5 miles from town by road and about 3 miles across country. The only way to get the birds that we dropped was to row out in the stream for them and the only boat that we could get was in Bill's woodshed.

The roads were still soft and I did not care much to push a boat, rigged on 2 wheels, through the mud for 5 miles, and told Bill so. Bill was 6 feet 5 and I was 5 feet 6, but somehow when we go shooting I have to do most of the boat pushing. Bill said he had just the thing, a new spaniel, a retriever that his brother had sent him, and that we would try her the next day; so, there being no boat to push, I said I would go.

Next morning, about 4, Bill rapped at my window and in 5 minutes we were footing it across country with our hip boots rubbing the skin from our heels, nearly frozen in our canvas coats, and our teeth chattering.

We chose a place where the river broadens to about 500 feet, a mile below the Santa Fe bridge, and there, by helping Nature a little, we soon had a blind that would have deceived a man, to say nothing of a duck. After putting out the decoys we squatted on a log behind the blind,

facing one another so we could catch the birds coming and going.

After sitting about an hour we saw a flock of 5 mallards coming down to us like the wind. We got ready and I waited until I heard the bang, bang, of Bill's right and left; then I pumped both barrels into the flock. Between us we got 4.

All that time the dog lay stretched on her belly, never moving an eyelash until Bill told her to fetch. She did not move. After some coaxing, Bill grabbed her by the back and threw her out as far as he could into the river. She turned once or twice in the water and then cut for the bank where we stood, without waiting to pick up a single bird.

I think Bill would have shot her, but I begged for another chance telling him the dog could not find dead birds unless she saw them fall. Meantime the whole 4 floated down the river out of sight. Back into our corners we went to wait for more luckless birds.

Pretty soon Bill saw a black speck up the stream slowly swimming for our decoys. We waited and watched until it got within range; we jumped and up it rose, a great greenhead.

It was Bill's shot and he dropped it with his left.

"Now for the dog," said Bill. He gave her a good start with his foot and we went down the river bank, the dog well in the lead.

"Fetch," said Bill, and in she went, straight for the bird that was fast being carried down stream. She reached it, grabbed it, swam across the river, laid the bird on the bank and then swam back to where we were waiting.

We did not get that bird either, making 5 we lost, for it was a mile to the bridge and a mile back on the other side, and neither of us would walk that far for one duck.

If Bill was angry when the dog failed on the 4 he was much more so when she returned empty mouthed from the other bank and I had hard work to save her from his wrath. In fact I had to threaten to tell the story to the whole gun club if he harmed her.

So she is mine, and as fine a spaniel as ever lived, even if she can not retrieve.

Johnny: How did you know I went in swimming?

Mother: A little bird told me.

Johnny: One of them darned English sparrows, I suppose.

## FOUR SURPRISES AT ONCE.

JACK WOOD.

At 5.30 on a cool November morning, I took my new 30-30 and started to make a tour of the fields around the edge of the woods, in hope to sight a deer.

On my return I glanced toward the house and caught sight of a man waving his arms. It was Jim.

My legs were lame and my feet sore from tramping through the woods, but you would not have suspected it had you seen me sprinting down that road. I reached the house pretty well winded, and found Jim peering at something down in the field in the valley. He had his old short barreled rifle in his hand.

"There are 2 deer down there," he said, "one of them has just gone behind that knoll, but the other one is over there by that big rock. Do you see him?"

"Yes," I said, and as I looked the deer raised its head and stood facing us. We remained perfectly quiet, and after a long look around, the animal dropped its head and went on feeding.

"It was no use for me to fire at them," said Jim. "My old rifle would not carry down there. I had been looking for you some time when I happened to see you crossing the road up there."

Fifty feet distant, back of the house, was a fence. I started for it, but the deer looked up. I halted and scarcely breathed until it again lowered its head.

I reached the fence and dropped behind it. As I did so the deer turned broadside to me. Ten seconds later I had raised the sight of my rifle one notch, rested the muzzle of the weapon on a pole of the fence, and was sighting at a point midway the length of the deer. Then I fired.

I had shot my rifle but few times and did not know how to sight it above 100 yards, consequently I was not greatly surprised to see the deer jump and run for the woods.

"Missed!" I thought. "Hang the luck!" But a second later I saw him come to a walk and stagger.

"He's hit!" cried Jim.

I began to think so myself, and soon saw the deer drop.

Then you should have seen the running down that valley. My lameness was forgotten. Jim is a long legged fellow and I am short, but I was not a great way behind him when he got to the deer.

"By gosh, it's a buck, and he's a dandy, too!" he said as I came up.

Here were 2 surprises for me; first, that I had hit the animal at all, and second, that it was a buck. But another surprise awaited me.

Of course I was greatly elated and fairly bubbled over in my exuberance of spirit; but I tried hard not to show it. I wanted to give Jim the impression that it was an easy matter for me to drop deer at 300 yards, measured.

We began hunting for the bullet hole. I had expected to find the deer badly torn by the soft nose bullet, but we had to hunt some time to find the wound; and then my third surprise came in that the bullet had not mushroomed a particle. It made a round, clean hole where it entered just back of the shoulder, another where it came out. Not a drop of blood could be seen.

Jim cleaned the animal. Then came my 4th surprise. My bullet, we found, had passed through the heart and the deer had bled inside profusely.

I returned to the city a few days later and the butcher who cut up the deer for me said it was the finest piece of venison he had ever seen; the meat around the bullet hole was scarcely discolored.

I want to know why that bullet, a Winchester, did not mushroom. I had been led to believe that a soft nose bullet expanded on impact with a substance whether hard or soft.

I want to go East again next fall and I wish to use a bullet in my 30-30 that will expand when it strikes a deer or larger game. Can anyone tell me of such?

---

Book Agent—Uncle, I'd like to sell you a new cyclopedia.

Uncle Swayback—Wa-al, young feller, I'd like ter hev one, but I'm afraid I'm too old to ride the blame thing.—Judge.

## LOST IN THE DEVIL'S GARDEN

J. E. TYLOR.

Photos by the Author.

Bound for the everglade country in Southern Florida, we left our train at Punta Gorda, and early the following morning took the steamer St. Lucie due to reach Fort Meyers in the evening. The placid waters of Charlotte harbor afforded rich relief to the dust and fatigue of railroad travel, and few were the moments when something of interest did not receive our attention. Frequently the waters were disturbed by the plunge of a pelican as he gobbled a big fish that imprudently basked

little traveled as to lose all trace of a track except in soft soil, while Mr. Hendry and I rode about, following the general direction of the wagon, looking for game. Old Pedlar, Mr. Hendry's deer dog, kept us close company, as did Cuff, Greene's cat and deer dog, also my faithful old coon dog, Bruce. The latter evidently thought this a grand coon expedition, for he put up several, and delayed us so much by striking trails that we tied him behind the wagon. The first 2 days represented much travel



AT THE HEAD OF THE DEVIL'S GARDEN.

on the sunny surface; the playful porpoises, chasing one another, bounded out of the water only to disappear the next instant; or a tarpon made a majestic spurt, cut the surface and sent spray flying.

Arriving at Fort Meyers, we were met by Mr. Louis Hendry, Mayor of that beautiful village, who had everything ready for the hunt. The following morning found us in the saddle, bound for the Devil's Garden. Mr. Hough, guide, and Rat Green, cook and camp man, drove the 2-horse wagon containing supplies. They followed the road, though a few miles out it was so

and little hunting. We had expected to find a deer or turkey on the way, but though signs were plentiful our course failed to lead directly to the live article. However, we used small shot to advantage, and Green snatched hide and feathers of quails and snipe at every stopping place. The morning of the third day found us still without venison. We had left camp but a few minutes when a doe gave Mr. Hendry the first shot of the trip. It was hit hard, poor thing, and went away, we hoped to recover. I also fired, but failed to score.

Later in the day Mr. Hendry saw a rat-



CAMP AT GRAHAM'S OLD SHANTY.

tlesnake, just as it drew back to strike at me. It was a wicked looking thing, about 6 feet long, and meant business. The evening before, I had carried a live  $5\frac{1}{2}$  foot water moccasin into camp, much to the consternation of Hough and Green.

"Don't you know that thing is certain death!" cried Hough. I told him possibly, if it got a fair swipe with its fangs; but having lassoed my moccasin securely I had faith that we would keep out of its reach. However, for the peace of the camp, I told Rat to tumble the bread in a grain sack and give me the bread box. Into that I put the snake and nailed down the lid. Even then Hough declared he would not sleep a wink unless that box was carried 100 yards back in the swamp; and back it went!

Looking closely at the newly found rattler, I observed its markings were unusually good, and thinking the moccasin might like company I decided to take the rattler, too. It was an ugly thing to handle, and after its capture the horse snorted and shied so much that I mounted with difficulty. Before this, the reptile gave my right eye a severe shock. I never knew before that the diamond rattler possessed skunk proclivities! I supposed only one end was dangerous. Mr. Hendry kept at a safe distance, and while he said it was a serious thing to laugh about, he shook until he almost rolled out of the saddle. I dropped bridle reins and snake, rushed

blindly into a pond 50 yards away, and almost washed an eye out; but that snake went into camp alive, all the same, though I thought Hough would have a fit.

Later in the day we arrived at Graham's old camp, at the head of the Devil's Garden. Graham had gone back there several years before, built a shanty, and, with his son, lived on hunting and looking after stray cattle. Another cattlemen arrived in the neighborhood, and in a dispute over a steer, Graham and son shot their visitor. The 2 were arrested and taken to Fort Meyers. While awaiting trial for murder, they broke jail and returned, it is supposed, to their haunts in the Devil's Garden. Lee county has now a reward of \$800 outstanding for the capture of either one.

The Devil's Garden lies Southeast of Fort Thompson, at the head of Caloosahatchie river, and about 48 miles East of Fort Meyers. It is a singular freak of nature, 3 to 12 miles wide, many miles long, a patchwork of ponds, bogs, sloughs, strips of land, hammocks, palmetto, and rank vegetation. In these wilds may be found small varmints of every description; also bears, panthers, black wolves, wild hogs and alligators. There are some deer down in the dark hammocks, but these, as a rule, prefer the more open palmetto country immediately adjoining.

Soon after we went into camp at the head of the Garden, Mr. Strickland and Mr. Drowdee, from Labelle, near Fort Thomp-

son, arrived with their trapping outfit. They came straight for Graham's shanty, prepared to stay a month and trap otters; so that evening the crackling of 2 camp fires shed a glow high up into the hanging moss and far out over nature's wild repose. Even the owls appeared to notice the sudden awakening of the old camp, and with their "wah-wah-hoo-hoo-ko-hoo" ventured surprisingly near.

After an early start the following morning Mr. Hendry clipped the lower jaw of a young doe with a 25-30 soft nose, smashing both bones. The skin acting as a hinge, the lower jaw flapped against the poor creature's throat as it ran away. We were distressed beyond measure at the thought of its lingering death from starvation, not even being able to quench thirst! After that we covered considerable country, and saw a number of deer. Mr. Hough made a noble effort to place me within range of a bunch of 8, which he discovered at noon feeding in an open slough; but while we were within easy rifle range, both carried shot guns, and these beautiful creatures, scenting danger, bounded away. About 4 o'clock in the afternoon, by the merest accident, I walked up to a small bunch of palmetto, of which there are thousands of acres, when up sprang the doe with the broken jaw! I did my best to make a sure shot. Possibly the same power which led me unconsciously to that stricken creature also enabled me to shoot straight. The doe was killed cleanly at 60 yards. The animal had bled but little, and not having had time to sicken and become feverish, was as fine as any venison secured on the trip.

Half an hour later, seeing fresh turkey signs by a hammock, I exchanged buck shot shells for those loaded with No. 2 turkey shot. There were no turkeys, but instead a large 4 prong buck sprang up. The range was close, so I gave him the turkey shot at 40 yards. It did the business, 5 No. 2's perforating the lungs, while 2 more pierced the aorta close to the heart. Mr. Hendry also made one of the finest rifle shots ever seen, the same evening, dumping a large buck in a heap, as it was springing in mid air. Near this deer our dogs took the trail of a panther, but could do nothing with it.

As the day's hunt had been so successful, I suggested that our party break camp in the early morning and return to Fort Meyers with the venison, giving them 2 days to reach home by Christmas, and leaving me with the otter trappers for several days. This plan worked admirably. I moved over to our neighbors' camp, where they gave me a hearty welcome, and I felt at home from the start. As we had no venison, and "fryin' grease" was getting scarce, we started out the next morning



STRICKLAND BRINGS IN AN OTTER.

looking for both deer and a fat pig. Remembering my bunch of 8 deer the day before, I carried my 30-30 Winchester. Mr. Strickland must have owned the first breech loader that ever came to America, as it was wired up and tied together in a number of places.

"Never mind 'er looks," he said, "if I pok 'er out right she'll do the business every time!". It was a fact that whenever old "rattletrap" did speak something dropped. Bruce had his coon up a tall pine before we had gone a quarter of a mile from camp. Mr. Strickland said it was a shame to disappoint the old dog, as I had already done on several occasions out of sympathy for the coon, so I decided to lift this coon out with my rifle, providing they would take care of the skin. Down it came. Its pelt was quickly removed, and proved to be an exceedingly fine one.

Soon thereafter we found fresh tracks of a large boar and several shoats. The ground was rooted up in places.

"If you come on 'em suddenly an' the old boar don't run, but throws his nose down and snorts, plank him one square between the eyes or else go for the closest tree and shin up like lightnin'!"

With this advice I momentarily expected a "snort" until we lost the tracks on hard palmetto ground. While trying to follow these, Mr. Strickland's old reliable suddenly lumbered off at my right. At the same moment I saw a spike buck crossing

my front to the left, scarcely 50 yards away. Supposing Mr. Strickland had shot at this deer and missed it, I promptly emptied the magazine of my rifle at the fast fleeing animal. His graceful bounds were not interrupted by the flying shot, and he flaunted his white flag with a majestic sweep at every crack of the gun. I became convulsed with laughter as the 8th ball started on a long journey to overtake him a quarter of a mile away. If that deer intended to stop short of Lake Okeechobee, he gave no evidence of the fact. Turning toward my companions, who were

came to securing tusks 9 inches long, even though it did entail a possible dangling from the first limb of a sapling pine! Mr. Strickland expressed much reluctance in allowing me to remain behind, saying, "these woods are mighty treacherous." They thought we were about  $2\frac{1}{2}$  miles Northeast of camp. I had my compass and expressed every confidence, after circling around a little, in being able to return by following a Southwestern course.

Finding myself alone, I gave Bruce full freedom. Soon he had a coon going, and after a lively chase caught it in the tall



LOST IN THE DEVIL'S GARDEN.

some distance to my right, I saw them standing by a dead doe and watching with much interest my vain effort to stop the young buck. Buzzards being bad, we concluded to carry the meat back to the camp without delay. I was heartily glad I had missed the young buck. One deer at a time if you please, and camp meat was all we were after.

It being yet early I asked to stay out awhile and look around a little, promising to return in 2 or 3 hours. Besides, having my rifle, I was anxious to find that old boar and put him out of the way. I wanted to take him in, hide and bristles, for I was a game hog all over when it

grass of a bog. Next came a gray fox. It climbed a straight tree 30 feet or more and stayed there until shot out. The wild hogs failed to materialize. I concluded to throw coon and fox over my shoulder and return to camp. Southwest I went, mile after mile, passing around hammocks, over sloughs and through palmetto until I had gone far enough to find camp twice over. Finally I realized I was lost. This feeling spread over me with a dumb chill. In vain I looked for some familiar hammock, but in that country it was a sad case of "all coons look alike." The thought of the many boggy miles between me and Fort Meyers almost made me desperate. If I



only had known whether I had passed above or below the camp, I could have figured out in a measure "where I was at." I decided to go no farther, but to find a dry place where I could camp for the night, toast a little coon or fox, and in the early morn return Northeast, hoping to get in the neighborhood where my trapper friends had left me and where I concluded they would first start to look for me. I took a personal inventory, finding 16 cartridges in my belt, also a box nearly full of matches. This was near the edge of a wide, open slough. Looking across I thought I saw smoke against the heavy vegetation of a dense hammock. Placing RECREATION'S handsome binocular glasses to my eyes, I was rejoiced to see that it really was smoke, curling slowly from a small opening in the hammock. Up went my spirits! To find a hunter or cattleman at that time was a Godsend! Across the slough I went, straight for the smoke. Approaching the hammock, I saw a solitary man moving about under the moss-laden trees. He stopped and looked in my direction. Taking no pains to keep him in sight, I entered the hammock, fully expecting a cordial greeting. But presto! My man had vanished. Two pine knots were slowly smoking, but there was no evidence of habitation; nothing under that hammock but bats and owls!

It required no argument to persuade me I was an unwelcome visitor! I knew I was in the Devil's Garden, but had not calculated on denning the Old Boy in his own camp! I walked out as straight as I had walked in. Didn't look back, either, and the farther I got the faster I went! Old Bruce was at my heels, a close second, and was

quite as ready to move on as I was. Straight back Northeast we went, through bogs which, before, we had gone around, and I was wet up to the waist. No curled up fox loin or crisp coon chips for me that night. The old Tennessee negro after seeing one "hant" in a lonely place, almost ran himself to death, until finally, exhausted and tongue hanging out, he paused to rest. Just then a second hant appeared and said, "You-certainly-kin-run!" As the old darkey lit out, he gasped, "No, honey, you ain't seen nobody run yit!" We were not afraid of hants exactly, but some powerful influence kept us traveling for about 5 miles, when, at sunset, we paused to consider. The wind was in our favor, straight from the North, and up in that direction I distinctly heard a gun go off. It was another inspiration to move on, and a short 2 miles returned us to camp just as Mr. Strickland was getting his night fireworks ready, and preparing to "scour these swamps till mornin' but what I would 'a' found you!" After that I stuck close to my trapper friends. Had I unconsciously walked into Graham's camp? Mr. Strickland thinks I had, and that the foxy old outlaw did not propose to entertain a stranger with a rifle, but on the contrary, from his place of concealment watched every move I made.

A crippled deer on Christmas morning, which old Bruce distinguished himself by chasing down and holding by the throat till we arrived, closed my hunt in the Devil's Garden. Mr. Strickland has since written that an 8-foot panther passed the camp the Sunday morning after my departure, and that he killed it.

---

## MY BALSAM PILLOW.

MEDA.

A camp fire burning clear and bright,  
A shelter rude of rough spruce bark;  
O'er all, the stillness of the night,  
Brooding the forest deep and dark.

In dreams I see Owaissa lie  
Again on couch of balsam bough;  
Oh sight to cause each care to fly  
That graves its furrows on my brow!

But at the throbbing in my breast,  
I wake. O Sweetheart, why didst flee?  
Come back and soothe once more to rest  
This aching heart, so true to thee.

Sadly I turn my pillow o'er,  
Of fragrant, spicy, balsam green,  
And breath a prayer at Eros' door  
That I may dream again, my Queen!

## MAMMOTH SHEEP HORNS.

I have just picked up a mountain sheep head that may be of interest to you and am sending you 2 photos of the horns and skull. The horns are not only remarkable for their great size but for the manner in which they curve in toward the head. The circumference at base of skull, following line where scalp was removed, is  $17\frac{1}{2}$  inches; length of each curve  $39\frac{1}{2}$  inches. The sheep was killed in British Columbia last fall and the head is one of the most

After seeing these photographs, Mr. W. T. Hornaday writes:

I have never seen any horns of *Ovis montana* so thick as these; and it is seldom a complete turn is made. It is interesting to know they came from British



SEEN FROM THE FRONT.



AMATEUR PHOTOS BY DR O. M. BECK.

SIDE VIEW.

remarkable I have ever seen. The horns grow so close to the head that 2-3 of the vision was obstructed by their position. The head is perfect in every respect.

H. M. Beck, Wilkes-Barre, Pa.

Columbia; and, as the great head formerly owned by Sheard, which once figured in RECREATION, came from there, it would seem that *Ovis montana* reaches its finest development in that territory.

---

## TO MY PIPE.

ARNOLD TOWNSEND.

I've stumbled o'er Toil's mountain steep,  
I've thirsted in Vexation's waste;  
Now while to earth night's cold shades  
creep,

To pitch my warm dream tent I'll haste.  
I'll take my rest, and light those beams  
Whose fancied glow from rocky heights  
My longings lured; and loose those streams  
Of pale, gray clouds, in gentle flights  
From drowsy fountain springs of ease,  
Whose dim blue mist and dreamy spray  
Through Care's gloom becked. I'll spill  
the lees

Of all discomfort of the day.  
A Nubian nymph with amber crown,  
By name Sweet Briar—blessed sprite—  
Those dregs will blithely simmer down,  
And give me moments of delight.

Hence, galling Fret and blighting Worry!  
Your helpless ghosts now bide my rule.  
In floating rings, I bid them hurry  
Aloft, and laugh as they seek the cool  
Night air, perchance to gain new life.  
Alas! that with another morn  
Such resurrections will be rife,  
And I again shall peer forlorn  
Toward my dream tent, and that sweet  
hour,

When cowering, fainting, dead, they lie,  
Those imps of Care, 'neath that great power  
Of subtle breath, Sweet Briar's sigh.  
Ah, rest thee gently, wearied heart!  
And rest thee softly, tortured breast!  
Content that one kind genie's art  
At eve is thine for soothing rest.

## DUCK SHOOTING ON IPSWICH BAY.

M. R. LOVETT.

The peculiarity of the duck shooting on Ipswich bay is that the hunter's success depends wholly on the storminess of the weather. As some men find their greatest pleasure in overcoming the hardest problems, so sea fowl glory in the crash of the surf, the wild sweep of the gale and the roar of the hurricane. On perfect days, when the waves gently wash the beach, too lazy to curl and foam, the duck flies far to find rougher waters, more worthy of his nautical prowess.

Most hunters, seduced by Nature's smile and fearing her frown, make their fruitless expeditions in August or September; but it is when November storms drive white capped billows across the bar to beat on the sands of Lakeman's beach, that the wise hunter frequents Ipswich bay. Then there are ducks in plenty. The black duck, fattened by his stay in Labrador; the mallard from distant Greenland; the coot, which has been driven into the Gulf of St. Lawrence; the little sheldrake, fresh from the dangerous Bay of Fundy; all these bob like corks on the yeasty water.

The bay is shaped like a bow, whose string is the wreck-strewed bar. Between its extremities, Tucker's and Plum Island points, is the crescent stretch of sea sand, the Sagamore ledges rising from the middle like the knuckles of a mighty hand. From the white lighthouses on the points, one can see, near at hand, the masts and sails of the Gloucester fishing vessels, a little farther the fateful rocks of Norman's Woe, and, 30 miles away, the brooding smoke column above busy Boston. Thus Ipswich occupies a central position of the North shore, but the sands of Cape Ann offer few commercial inducements and the duck hunter and the wild fowl are its only visitors.

There are 2 methods of hunting ducks; one by means of decoys, from the land; the other, by means of sailboats, beyond the bar. The preference of the duck for stormy weather makes both difficult and even dangerous, but only the boldest spirits dare try the uncertain sea; the greater number of hunters shoot from the shelter of the land.

Let us follow one of these latter some bleak November morning. In the early hour before daybreak, gun in hand, he walks along the shifting beach, half smothered by the swirling sands, and takes his place with his decoys among the fallen fragments of Sagamore cliffs. Even there he is not comfortable; to shiver in the chill morning air and at the same time to be sandpapered

by the gritty blasts, surely is disagreeable.

By this time the sea birds are astir. Above the roar of the water the whirl of countless wings can be heard, and against the blue gray vault flit passing shadows. As yet the ducks do not alight. Not until dawn pales the yellow shafts from the beacon lights, do the ducks appear. It seems to be breakfast time and all are busily feeding on the tender shellfish, insecurely sheltered by the crashing combers. The live decoys, encouraged by hereditary love of water and the presence of their wild relatives, breast the breakers and join also in the repast. Interested by unlimited oysters on the half shell, and deceived by the presence of the tollers, the ducks gradually approach the deadly rocks. Now they are so near that, as the sun, half risen from its early bath, surrounds them with a blazing path, we see the sparkling drops cast off by the oblique flit of the blunt tails on the downward plunge, and, as they rise from the long immersion, the satisfied but wary shake of the head, as if the unseen morsel had tasted well. The fowler calculates the distance—100, 75, 50 yards—and the glittering barrels of a shot gun point down the heaving, fire-paved road. Crash! Bang! The survivors fly confusedly away. The steep bluffs echo the roar, the noise of the surf is drowned by a greater sound, and, at the cessation of the customary din of the sea, the gulls soar screaming from their rocky homes; but behind are a score of inanimate objects floating in on the crashing waves to be hurled at the feet of the slayer.

The duck's worst foe is the gliding sailboat. As he wings his way affrightedly from the hostile shore, to drop into the ocean by the bar, he meets new and more terrible enemies. There is no rest. Hardly has the little patch of foam made by his alighting been swallowed up, when he is surrounded by the shark-like boats of the sea.

If we would join this little flotilla with our dory, we must take with us a good stock of courage. We must forego the last few hours of sleep and pass into the bay before the moon pales in the West; we must be ready to get as wet as the duck himself.

Near the great bar the water heaves with the concentrated swell of the Atlantic, and spoon-drift flies like hail. For an hour we hover on the edge of the great breakers, so near that the spray drives over us in clouds, and each sea threatens to swamp the boat as it piles up for its final plunge. At last the man in the bow points toward the bar and we see the ducks, rising and

disappearing on each wave. The tiller is pushed hard over, the boat jibes and on we go toward apparent destruction. The wild birds do not notice the white phantom approaching. Now they are only a few rods away. A flash, a report, and the gulls fly with harsh cries from their haunt in the skeleton wreck; but the ducks do not fly. The little flock floats head downward.

Down in a shifting trough, up on a crest, which quivers and breaks a rod beyond, and we pick up the game. An instant's hesitation, the jib flutters slowly, we hover a second and then slide into the ocean beyond. We have experienced what every fowler who shoots about Ipswich bar goes through; danger, excitement, pleasure, with final success.

### YANKED OUT OF PARADISE.

Parties go regularly from this city to adjacent lakes and invariably return with long strings of fish to attest the fact that the waters of Florida are prolific and afford the sportsmen a paradise. George Macy is showing a photograph of a part of a string of fish caught at Sand lake, where he has a fishing lodge. There are 65 large trout shown in the photograph and there were 135 more not shown, but all caught within a few hours.—Orlando, Fla., Daily Record.

hours. I send a photo of 3 boys and 2 girls, and of some 65 of the over 200 fish they caught on that trip. I hope it may prove interesting to sportsmen.

Geo. E. Macy, Orlando, Fla.

This picture is reproduced here simply to give another illustration of the low type



FLORIDA CRACKERS IN THE PEN.

In reply to your inquiry, I will say that 3 of my employees went recently to my country place, among the lakes, and caught over 300 trout in one day. Fishing is excellent there. One of my sons and another young man took 150 trout and bream in 3

of people who commit this kind of slaughter. Anyone who looks at the faces of these people will promptly draw his own conclusions as to their character. Their numbers in the fish hog pen are 904, 905, 906, 907 and 908.—EDITOR.

In a Montana hotel there is a notice which reads: "Boarders taken by the day, week or month. Those who do not pay promptly will be taken by the neck."—Tit-Bits.

## HELIOGRAPHING ON MOUNT ADAMS.

C. E. RUSK.

For the enjoyment of its members and to stimulate interest in the magnificent scenery of the Pacific coast, the society of Mazamas was formed on the summit of Mt. Hood, July 19, 1894. On that date 193 persons reached the highest point of the lofty peak, and there took part in the ceremony of organizing the club. The second annual climb of the society was fixed for July 10, 1895, and Mt. Adams, Washington, was selected as the mountain to be climbed. In addition to this, parties were to make the ascent of Mts. Tacoma, Baker, Hood, Jefferson and Diamond Peak, with heliographs, for the purpose of establishing communication between the members of this chain of mighty snowclads. In accordance with arrangements, 82 persons assembled at Mountain View camp, preparatory to making the climb July 10th. With one companion, M. F. Derting, I left Wetemis Springs, on the Klickitat river, July 8, to join in the great undertaking. A hard day's horseback ride took us to the snow on Mt. Adams. To our disappointment we found that the snow extended far below the timber line, making it difficult to find a camping place with sufficient grass for our horses. We finally selected a timbered ridge, surrounded by snow, where the young grass had grown enough to furnish fair grazing; but we abandoned the attempt to reach the Mazama camp, which, we judged, was several miles West of us, and decided to ascend the mountain alone.

During the afternoon, we made an excursion to Hell Roaring glacier and viewed the awful grandeur of the Eastern precipices of the mountain, the home of glaciers and avalanches. Returning, we constructed a brush shelter for the night, to ward off the East wind, which had gained a disagreeable force. The air, which the day before had been remarkably clear, was rapidly becoming filled with smoke, from forest or prairie fires. We went to bed early.

Between 2 and 3 o'clock we arose and soon had a booming fire. The East wind still swept the ridges and broad fields of snow, chilling us through. We secured our horses for the day and then sewed gunny sacks around our feet to keep the lava boulders of the lower ascent from cutting our shoes. After breakfast we started, with a lunch and our overcoats done up into small packs.

It was 3.40 o'clock. The wind still howled through the scanty trees, but the sky was clear. However, the smoke, which had been gathering the day before, hung heavily over the lower country, threatening to shut off

all view of the land beneath. We struck on to the snowfields and traveled gradually up the slope, toward the mountain, for about an hour. Finally, we reached the line where all vegetation ceased and the mountain became steeper and more rugged, with ridges strewn with huge volcanic boulders. The mighty mass of Adams still towered above us. No trace of the Mazamas appeared and our conviction that they were camped farther to the West was strengthened.

Southward from the dome of Adams runs a great lava ridge. Like a huge backbone, it slopes downward to the timber line. On the East it breaks off abruptly and beneath it lies a vast field of snow, of unknown depth, seamed with frightful crevices. On the West it is not so precipitous, and one may gain the ridge from that side, along its entire length. To get on to it from the East, however, a person is compelled to keep well down, in order to avoid the dangerous seams and steep rocks. Compared with the other slopes of the mountain, this ridge is gradual and is, therefore, always selected as the route of those making the ascent, notwithstanding the fact that it is strewn with big boulders, whose sharp edges cut into shoe leather with knifelike keenness. Toward this ridge we bent our steps. To reach it we were compelled to cross the lower end of the vast snow field; but it was there almost free of visible crevices. We had not traversed half the intervening distance when the wind, which had previously abated, struck us with fearful violence. It seemed to suck down from the mountain between 2 ridges and its force was so terrific that we were scarcely able to stand against it. We tied our hats down over our heads and bracing ourselves against the hurricane, worked slowly toward the lava backbone, stopping every now and then to catch our breath for a new start. Our progress across this field of snow, from which, at times, it seemed we would be swept bodily, required but a short time, yet it was not pleasant while it lasted. We reached the point of the ridge and clambered up the slight bluff where the snow and the rocks met. There we caught a glimpse of the yawning gulf between the snow and the precipice as we went over; but our snow bridge was solid and we soon stood on the backbone, with no danger of being blown away, yet still confronted by peril, as a misstep among the boulders, in our efforts to make headway against the hurricane, might result in a broken, or badly sprained leg.

A black pall of smoke hung heavily over everything. From our great elevation, not even the summit of Mt. Hood could be seen. Through the smoke the sun rose like a great red ball of fire. Everything had a strange, weird aspect that savored of some other world than ours. The wind seemed to have no effect on the smoke. The dark ocean hung as still and leaden as though not a breath of air was stirring.

Our course, which, up to that time, had been Northwesterly, then turned to the North. We went up the ridge directly toward the dome of the mountain. The wind continued to blow furiously and it was with the greatest difficulty that we made any headway against it. One of us, while climbing over a large boulder, was actually blown off. Nevertheless, we fought our way slowly upward, stopping often to get breath and a little rest. As we proceeded we saw, after a time, that the wind was diminishing in force. That gave us new courage and we hastened our pace, soon arriving at a point where the ridge intercepted the main, steep slope of the peak.

Glancing to the West a few hundred yards we saw 2 men steadily making their way across the snow, toward the great slope. Each carried a pack and was armed with a long alpenstock. They were progressing rapidly and they proved to be Mazamas. Waving our alpenstocks aloft we shouted to them. After some delay they saw us, among the rocks, and answered. The desire to be the first to reach the top took fresh hold of us as soon as we knew certainly that we had competitors. Neither party had much the advantage in position, although we had no doubt they were better equipped for climbing than we were. It was also likely that they were among the best climbers of the club and as yet we were not so sure of our ability to cope with them. We resolved, however, to do our best, determined not to give up the contest without a desperate struggle.

Between the upper end of the big ridge and the long slope is a slight depression where a few small gravel beds lie between the glittering stretches of snow. Down into this depression we hurried; but were compelled to halt and re-arrange the gunny sacks on our feet. That lost us considerable time. We could see old tracks in the gravel which, we judged, were left by the party that had taken the heliograph to the summit some days previous.

Once more we turned to the mighty, glistening slope, that towered above us in almost unbroken monotony. About 200 yards to the West a streak of the rugged boulders stretched up the mountain to the first summit. Four years before I had been glad to seek the shelter of those big rocks, while attempting to ascend the mountain in a ter-

rible storm. This time, however, we chose the snow as a better footing. The crust had softened considerably while the wind, strange to say, had subsided to a gentle breeze, cold and bracing.

Then came the tug of war! We observed that the Mazamas were hugging the rocks. Their number had suddenly increased from 2 to 6, and they were making what looked to us alarmingly rapid progress. Experience had taught us, however, that haste is worse than useless on a big mountain and he who takes his time will probably come out ahead in the end. Slowly and steadily we pushed upward. The great ridge fell farther below us, the smoke above us became thinner, while the dark bank beneath grew blacker and more impenetrable.

The Mazamas were clearly separating. Two were falling behind while one was forging ahead of his companions. He seemed to be a magnificent climber. Soon he was quite a distance in advance of us and still gaining. Since our exchange of signals with the first 2 no communications had passed between them and ourselves. We were not within speaking distance and that was no time to waste precious lung power in needless yells. We struggled upward with little change in our relative positions. After awhile, however, it seemed to us we were gaining slightly on the foremost of our opponents. This slowly became a certainty. Our former suspicion that he was overdoing himself proved correct. Steadily and surely we passed him and after we had once gained the lead it was astonishing to see how quickly the distance between us and the others increased. We might have been led to think they were going back had we not been able to see them still clambering up over the rocks. Suddenly Mr. Derting exclaimed, "Hood! Hood!"

Far away to the South, the sharp peak of Mt. Hood rose above the wall of smoke, seemingly suspended like a mighty white bell between heaven and earth. It was the only point of land to be seen in that vast ocean and its lower portion was invisible, while the summit looked more like a phantom of the air than a substantial portion of *terra firma*.

We had been bearing to the left for some time and that course at length took us to the streak of bare rocks that the Mazamas were following. When we reached it we were about 200 yards in advance of them. The man who had made such good time at the start had been passed by 2 others.

During our climb up the snowy slope we, from time to time, saw men advancing, singly and in pairs, across the gradual declines far below. From our elevation they appeared as mere specks on the snow and

we were glad we were not back with them. The Mayamas immediately beneath us were doing comparatively little traveling, so we spent some time in looking backward. A few more short pulls up over the boulders across a bit of gravel and we stood on the edge of the lofty plateau known as the East summit.

A thousand feet above us towered the true summit. We hurried across the snow-laden plateau and started on the last great climb. Our choice of routes lay between a ridge of lava gravel and the snow, which had thawed and frozen alternately, leaving depressions which furnished good footholds. Most climbers choose the ridge; but we took the snow. Our progress up this slope was slower than any we had made. Our forced climbing had begun to tell on us, but we pushed slowly on. Reaching the highest point of rocks we found a record box that had been left by the old Alpine club of Portland, Oregon. We did not stop long to examine it, but turned again toward the summit, which in a few moments more would be ours. Across a slight hollow and up the gradual slope on the other swell we went. In a short time, flushed and triumphant, we paused on the top of the mighty snowclad, glanced downward, and, waving our alpenstocks, shouted to the Mazamas still struggling upward from below. They waved their alpenstocks and shouted an answer. Our watch recorded 9.10 a. m. We had been  $5\frac{1}{2}$  hours from the camp, or  $4\frac{1}{2}$  hours on the real climb; the quickest ascent ever made.

The mountain was completely surrounded by a black wall of smoke. Miles Southward the sharp summit of Hood rose out of the inky mass, while in the West the pure symmetrical dome of St. Helens sprang into the clearer air. Looking away to the North, we could see the rugged, monstrous bulk of Tacoma, glistening so brightly in the sunlight that it appeared close at hand. These giant peaks were the only indication of land anywhere in the universe, save the pinnacles on which we stood. Between us and them there was naught but gloom and darkness. There was no lower world. Our isolation was complete.

After viewing our surroundings we traversed the summit from East to West and then returned to the Eastern edge to test our nerves by looking down the frightful precipices of the East side. Cautiously we approached the verge and peered over. We drew back, our senses reeling and our minds appalled by the fearful grandeur of the scene. A few feet from where we stood, the snow broke off abruptly, making it extremely hazardous to approach near the edge. Down nearly a mile of almost perpendicular height, broken here and there by jagged cliffs, huge masses of detached

snow and yawning crevices, we gazed. From the foot of this craggy, variegated precipice the glaciers, seemingly so far away as to be in another sphere, pushed their way down the mountain side until lost in the terminal moraines. The Little Muddy, springing from these ice rivers, wound along its great canyon till the smoke swallowed it from sight. The view was grand, awful and appalling.

We turned away and, taking a position facing old Tacoma, ate our lunch. Scarcely had we finished when 2 Mazamas appeared, their arrival being half an hour behind our own. They brought the heliograph, which had been left at the last rocks by a party that had made the ascent some days before. In a few minutes a third reached the summit. From these gentlemen we learned that it had been decided at Mountain View camp, where the Mazamas had met, to postpone the general ascent until the next day, in view of the unfavorable condition of the weather. However, it was deemed necessary for the scientific party to make an attempt, as the extensive arrangements previously made required that each should do his share of work if possible. Besides, a number had decided to try the climb on their own responsibility.

It was soon observed that the smoke was rising, threatening to hide what was visible of the great snowclads. Soon St. Helens disappeared, leaving only Hood and Tacoma.

Singly and in pairs, climbers continued to arrive. The wind was then slight, but cold, and several returned to the rocks below the summit to eat their lunches. Secretary White reached the top and a canvas was stretched on alpenstocks to ward off the breeze. Two heliographs were trained, one on Hood, the other on Tacoma. Prof. McClure improvised a frame for his mercurial barometer, and the stars and stripes were unfurled.

Noon came and went without a sign of life from the other mountains. Suddenly a flash from the summit of Mt. Hood! At last the sun-telegraph was calling to the operators on Mt. Adams. Mr. White sprang to his instrument and soon giant was flashing unto giant.

"This is Coolidge," came the message from Hood.

"This is White," answered Adams.

It was plain, however, that all communication with Oregon's monarch must soon cease, for the smoke was slowly and surely swallowing the white sentinel from view. The operator on Adams sent a message, stating how many had already reached the summit and that the main party would make the ascent next day. Those on Hood could not read this and after a number of flashes had been exchanged, the relentless smoke

ended the remarkable proceedings. The peak South of the Columbia grew dim and men disappeared entirely. Two of the mighty mountains were thus lost, but Tacoma still rose clear and distinct. During the entire afternoon it stood out brightly glistening in the sunlight. Notwithstanding the fact that a party was on its summit, vigorously heliographing to Adams, not a flash did we see, nor were any of the signals sent from Adams seen on Tacoma. This was strange, since Tacoma could be seen much more distinctly than Hood, and powerful telescopes were brought to bear from time to time on its crest.

As soon as heliographic communications ceased, attention was turned to the homing pigeons, which had been carried up. In the meantime the report had come that 2 young ladies were slowly making their way toward the top. Four pigeons had been taken from Portland lofts. Two of these were prepared for departure. Messages with the names of those on the summit and information regarding the heliographing, barometer readings, etc., were attached to their tails.

A feeling of pity for the poor little birds went over me. They seemed so helpless and so frail away on that lonely mountain, surrounded by miles of almost impenetrable smoke. On being released one of them immediately dashed off, closely followed by its mate. Swiftly as arrows they flew, directly toward the huge rock point that leans for support against the Western side of the central dome of Adams. Before reaching it they circled to the left and were soon hidden by the shoulder of the mountain. They were never seen again. The 2 released later in the day fared no better.

Soon after the flying of the first 2 pigeons the young ladies reached us. Their advent was the signal for an outburst of enthusiasm.

The afternoon was wearing away and my companion and I were compelled to think about retiring in order to get our horses to better grass before nightfall. We were invited to register our names in the new record book, which had been taken up during the day. All persons were to be registered in the order of their arrival at the summit and it gave us much satisfaction to place our names first. The book was afterward put in a box which was fastened to the rocks nearest the summit. Having written our signatures on the roll, we bade our new friends goodbye and turned our steps toward camp. We could not go, how-

ever, without returning to the Eastern brink and once more looking down the frightful height. Then, with a last glance at the group on top, we plunged downward. We paused to examine the old record box that we had seen on our way up in the morning. I was gratified to find that it contained a postal card bearing my own name and that of a companion, which we had left in an old sardine box on that very spot over 6 years before.

Again leaving our signatures we started on down the mountain. On the East summit we met a gentleman who had become ill during the ascent, but he was still pushing slowly on, saying he would reach the top or die in the attempt. He got to the top, but did not die.

On the long steep slope we found the snow too rough for good sliding, but we enjoyed a slide on the steepest part. Persistent climbers were still struggling on toward the summit. We rapidly traversed the snow fields below timber line, arriving at our camp at 5 p. m. Hastily saddling our horses we packed our few effects and by nightfall were encamped on Bird creek far from the snow line.

The next day we were almost blind. Our eyes were swelled nearly shut and we suffered so much pain that we were compelled to ride with them closed, occasionally prying them open long enough to enable us to keep our bearings. In spite of this peril we arrived home safe and in a few days, thanks to the effects of soothing applications, were restored to our usual good sight.

Twenty-four persons reached the summit of Mt. Adams July 10. Although July 11 had been finally decided on for the main ascent, only 14 persons reached the top that day. The following day 3 more climbed the mountain; making a total of 41. About 70 made the attempt. Owing to the smoke, the heliographing was a failure, excepting between Hood and Adams. Parties also made the ascent of Tacoma and Jefferson, but the Mt. Baker party failed. The most important result was finding the approximate altitude of Mt. Adams. The height of the mountain had been given by most tables at less than 10,000 feet; but this ascent proved that it exceeded 12,000. Those who had climbed Hood found the climbing of Adams to be longer and more difficult than that of the former peak. Henceforth Mt. Adams will take its rightful position as second among the great snow peaks of the Cascades. Tacoma alone overtops it.

---

Pat—An' so yez shtruck fer shorter hours?

Mike—Yis. We want each wan to consist av 40 minutes, begorry!—Puck.



## A WEST TEXAS HUNT.

HON. H. S. MORAN.

Perhaps no State in the Union has held so great a plenitude of game as Texas, but hide and meat hunters, until the passage of the act of 1897, prohibiting the shipment of game and hides, held high carnival on her broad prairies. They pursued the ever retreating quarry to the Rio Grande, and have left but a small remnant of antelope, deer and turkeys. These live now in the most remote and roughest districts, including the river bottoms and canebrakes of Eastern and Southern Texas, the mountain districts of Western and Southwestern Texas, and on large ranches where they are protected; hence before one can hunt it is necessary in many parts of the State to obtain permission from the ranchers.

I was one of a party of 10 that traveled 600 miles within the State last fall for a few days of hunting. We were bound for Alpine, the county seat of Brewster county, in the mountains of West Texas; a typical Western village, nestling in a grassy valley at an elevation of 4,500 feet and surrounded by mountains towering 7,000 to 8,000 feet.

There, with the assistance of our friend, Judge Vanssickle, we outfitted with grub wagon, 2 mountain hacks, a Mexican cook and a negro horse wrangler and general servant. Saddle horses were furnished by the ranchmen. The most appreciated of John's varied duties, he having been recommended as an expert broncho buster, was to mount first, in the morning, all ponies suspected of a disposition to gratify that ever present propensity of the West Texas cow pony, to convert the landscape into a circus ring for the amusement of himself and all except the tenderfoot who happens to be "clawing the leather."

Our eagerness to reach the game fields, which the old stagers of the party could not repress, led to a hurried start for Haley's ranch, 15 miles out, leaving the grub wagon to follow as best it could. To our dismay we found the ranch house deserted and everything locked tight and fast. After traveling the road, we knew no wagon could reach us that night. We had not seen a house on the way, and had no idea whether it was 10 or 40 miles to another. A foraging party found 2 cans of corn, a can of tomatoes, a can of lobsters, and a can of cove oysters, which had been indiscreetly left out on the porch. We built a fire in front of the house and were preparing to cook the food in a tin bucket when to our great relief a man rode up, having been sent by Mr. Haley, who happened to be in town. The man took us in and prepared a good hot supper.

The next day we concluded to try for a deer, while waiting for our delayed grub wagon and cook, and on Cathedral mountain I killed a doe, which gave us our first fresh meat. Our party sighted 5 deer and a bear that day; but we were going for our hunt farther down toward the Rio Grande, and the next day set out, Charley vowing that never again would he get out of sight of the grub wagon. That day we reached Jackson & Harmon's ranch, where we were received and entertained with Western hospitality. Not only were we fully informed as to the haunts of game, the few watering places, and such useful and practical points, but the store house, the ranch horses, saddles, and the services of the cowboys were ours to command. They even offered us the fattest yearling on the ranch if we needed it, but we did not.

We pitched our camp a few miles below the main ranch house, and Mr. Harmon joined us, assuring us that plenty of game was to be had there. Having spent 2 days prospecting the range I was convinced that it was unnecessary to go farther, but nothing short of a demonstration by a day's slaughter, of which we were heartily ashamed, when the game was piled up in camp, would avail to convince others; so with Charley, one of the best shots in the crowd, I mounted at daylight and set out for the South end of Elephant mountain. After riding as far up as we could get the horses, we dismounted.

It is a most peculiar country, evidently having at some time formed the bed of an ocean. It now consists of valleys, or mesas, perfectly level and at places many miles across, but out of which, ever and anon, rough, rocky mountains shoot up several thousand feet, seamed and stratified with different kinds and colors of rocks, and strewn with burnt out lava beds. Some of these mountains are almost without timber, but most of them have more or less live oak, cedar, pine and pinon. Their sides are cut with deep and sometimes impassable canyons, affording favorite haunts for bears and mountain lions, of which there are many. The mountains consist of a series of steps, or benches, which, viewed from below, look smooth and of easy ascent, but a closer acquaintance discloses an extremely rough, rocky surface, covered with all the prickly, thorny growths known to the Mexican dialect, and to withstand which, shoes and clothing must be of the best.

The top of Elephant mountain is a precipice of rock, at most places impassable for man or beast. Sending Charley, who had

never killed a deer, to the last bench under the cap rock, I took the next below, which placed several hundred yards of granite and cactus between us. We had proceeded but a short distance when I jumped and shot a yearling doe, but we failed to find her, though I was sure I saw her fall. As the morning was rapidly passing we gave her up, temporarily, and proceeded. We had not gone a quarter of a mile when Charley's 30-30 began to crack so fast and spitefully that I, though a mountain of rocks intervened, sought the South side of a huge boulder and only looked up occasionally, to take advantage of any fleeing buck which might hunt a lower range.

A bunch of 3 bucks and a doe had gone up the steep mountain, thus giving Charley full play, which he used to advantage as his triumphant yell announced. In going to him, the steep rocky ground compelled a slight detour, and when I had struggled up almost to the top of the bench a 5 point buck jumped below me and ran around the mountain, passing me at about 100 yards. After waiting until I decided he was not going to stop, I shot, but with no apparent effect. Before I could fire again he had run around the mountain until he presented an almost straight away shot, which I took, striking him in the back of the neck and tumbling him in a heap. The first shot, striking back of the shoulder, would have done the work. After dressing him, I scrambled up to Charley, who had 2 bucks dead, about 100 yards apart.

Charley had broken his water bottle and as we were thirsty he offered to go after mine, which had been left with our saddles. On the way he jumped and shot another buck and found the doe we had lost in the morning. Charley went to camp, about 2 miles distant, and brought a hack to the foot of the mountain; also some horses, and

all the help in camp. By dragging the deer down to where we could reach them with horses we got all to camp, after dark.

Two others of the party divided honors in killing a young doe that day. The previous day Ed. had killed a 5 point buck and had brought in one shot but lost the day before. While 3 of our party had killed no deer, they all agreed he had enough, and must get home with the meat as quickly as possible.

We had killed no bear, so it was agreed that all but I, who volunteered to stay in camp and help prepare the 6 deer for transportation, should go on the morrow, with Mr. Harmon and his splendid pack of bear dogs, over toward Santiago mountain for a bear. They promptly jumped one, but he led them such a lively chase, over foothills, ravines and canyons, that all but Charley were left behind in the mad run of 6 miles. One by one they returned to camp, with the comforting assurance that the others would get the bear. Sure enough the dogs stopped him in a cedar brake, and Mr. Harmon and Charley dispatched him with 6 shooters; the fellows with long range guns all having dropped out. He was a black bear weighing about 350 pounds and though they killed him 12 miles from camp, it happened to be near a wood road, and we went after him with a hack and took him out that night.

We broke camp next morning for Alpine, reaching there in time for our train. In 4 days' hunting we had killed 9 deer and a bear. Near the limit, think you? I fear so, and while I have hunted from the Texas coast to Wyoming, it was the greatest kill I have ever engaged in. I think we deserve to escape your pen for stopping in such a game district, where 3 of our party had killed nothing; but even they said, "We'll quit, we have enough."

## A PLACE THAT'S UNDER KANSAS.

H. N. BEECHER.

(With apologies to Vermilya and White.)

There's a place that's under Kansas,  
Far below fair Persia's dell:  
It was built for would be critics,  
But forgive them, they mean well.

When a fellow writes a poem  
On a country that's on top,  
Then another, who's not in it,  
Dips his ink and makes a blot.

But this country, broad and spacious,  
Is quite big enough for all:  
So forgive the would be critic  
For his verses; they're just gall.

## DEER IN COLORADO.

M. S. BACON.

The judge and I left Denver the 25th of August, 1902, over the Colorado Midland, and reached Rifle, Colorado, 350 miles distant, the same evening. At 10 o'clock the next morning we resumed our journey, by stage, to the bustling little town of Meeker, 45 miles from the railroad, arriving there about 8 o'clock that evening, tired and hungry. After another night's rest we were conveyed by Mr. H. P. Spurlock to his ranch, the Mountain Brook resort, which lies 15 miles Northeast from Meeker.

About half past 2 in the afternoon Mr. Spurlock invited us to pick our horses and accompany one of the guides for a trial of the horses to see how we liked them. Our real sport was not to begin until the next day, when we should reach our final camping grounds, 15 miles still farther back in the mountains, accessible only by saddle and pack horses. At half past 5 that afternoon we were skinning our first deer, a 2-point buck, having seen 7 all told in the 3 hours we were out and not more than 5 miles from the ranch at any time. Our host had already fulfilled his promise to show us game. Our guide did not carry a gun, so it rested with the judge and me to replenish the larder or go hungry, as far as venison was concerned. The buck received 4 wounds before he fell. The wounds showed bullets of different caliber, and as the judge carried a 38-55 and I a 30-30 Savage, we concluded we might both claim an interest in the game.

Early the next morning we set out with saddle horses for our final hunting ground, with full camping outfit on our pack horses. The party consisted of Andrew Goff, the guide and a brother of John Goff, who guided President Roosevelt on his famous wildcat hunt; Alfred Austin, the cook; the judge and me. We reached camp about 2 o'clock in the afternoon, and, eating a hasty lunch, Andy and I started for a short hunt. The judge could not be induced to accompany us, being completely fatigued with the long, hard ride. Andy and I returned to camp that evening shortly after dark without game. We had seen 14 bucks, does and fawns, but they were so wild we could not get within range of them. Andy explained their wildness as being caused by the existence of a club house some 10 or 12 miles away, where 200 to 300 sportsmen were making their headquarters, thereby driving the game all our way.

We all retired early that night, fatigued with our day's work, only to be awakened

about midnight by a heavy storm, the rain coming down in such torrents as to soak through our tents and stand in puddles on our tarpaulin cover, as well as splashing in our faces; but by frequent shifting of position we kept reasonably dry.

Early the next morning we were in our saddles, headed for the mountain known as old Baldy, 8 miles farther back in the range. The rain of the previous night made traveling anything but safe or pleasant. After going about 5 miles from camp we separated, the judge and Alfred taking one direction, and Andy and I going at right angles. During the day Andy and I saw 50 to 60 bucks, does and fawns, which we watched nearly 5 minutes. They had discovered our approach but did not seem frightened until we started toward them, when they scampered away. That being, of course, the first time I had left my kodak at camp, my opportunity for a snap shot at the fawns in their native heath was lost.

On arriving at Old Baldy we were fortunate in spying 7 fat deer, 3 bucks and 4 does, in a ravine between 500 and 600 yards distant. I dismounted, and, taking deliberate aim at the largest buck, had the satisfaction of seeing him respond to my greeting by humping up his back much like a bucking broncho. He did not move out of his tracks until his companions, hearing the shot, scented danger and started on the run for safety. Then he attempted to do likewise. I gave him another greeting, just as warm and cordial as the first, but saw him disappear around the point. Hastily mounting, we hurried to the place where the buck had stood and easily tracked him, by the bloody trail, about 100 yards, where we found him cold in death. He was a 3-point buck and weighed about 200 pounds. Both bullets had taken effect. The first severed the aorta, passing through the body, and was cut out just under the skin on the opposite side. The second bullet had pierced the paunch and taken a direction lengthwise of the body toward the head. Either bullet would have proven fatal.

We dressed our prize, protected it so that wild animals would not molest it, and started for camp, intending to return with the pack horse in the morning for the venison.

The judge, in the meantime, succeeded in locating a 5-point buck contentedly resting under a pine tree, unaware of the proximity of danger. The buck presented

a broadside not 50 feet from the judge when he pulled the trigger, and, although standing still, the judge missed him entirely. He was gone before the judge recovered from his surprise and chagrin. Be it said to the judge's credit, however, that he was not using his own gun. The day previous he had killed 2 grouse in as many shots with his own gun, having completely severed the heads from the bodies as clean as though cut with a hatchet. He partially redeemed himself regarding the deer, however, for when Andy and I reached camp the judge and Alfred had preceded us and were preparing a feast from a 2-point buck killed by the judge. My buck proved the largest one killed during our trip.

The judge seemed to be the only unlucky man in our party, for while returning to camp his horse slipped and fell in descending a steep mountain. The judge had just time to release his feet from the stirrups and jump. When he recovered himself the horse was standing on a ledge some 15 feet down the mountain, shivering like a man with the ague and seeming to realize its danger. Two feet more and the horse would have fallen over a precipice of 100 feet drop.

We experienced all kinds of weather, from 90 degrees in the shade to zero. The afternoon we went to Old Baldy we encountered what started to be a rainstorm, but when it reached us it was snow or

frozen ice, accompanied by a biting wind which pierced to the very marrow. We were glad to seek shelter under the friendly and inviting fir trees until the storm ceased.

On comparing notes we found we had seen over 100 deer that day; yet only the day previous some ranchers who lived about 20 miles distant and who had been hunting in the vicinity, came to our camp and said they had not seen a deer. This shows that if you take a guide who is familiar with the country and knows his business he is worth all he costs if you are really after the sport.

We could easily have killed other deer had we not secured our limit, and being believers in the doctrine promulgated by the L. A. S., we did not, of course, attempt to infringe the law.

The next morning, after securing our venison, we packed our belongings and set out for the ranch, agreeing that we had had one of the most enjoyable trips of our lives.

There are bears, elk and wildcats in this same locality later in the season. The snow had not begun to drive them down from their summer quarters, and the judge and I sealed a compact for a return to that locality next season, with the understanding that we should go late enough for a chance at a bear.

## WHEN MY SHIP COMES IN.

A. L. VERMILYA.

I am waiting for a vessel that is sailing  
o'er the sea,  
Bringing, 'mid its costly cargo, wealth and  
happiness for me;  
I can hear the sailors singing as they reef  
the tattered sail,  
While the tropic sun is dying and the moon  
is shining pale.

Long this ship has braved the ocean, beat-  
ing forward night and noon;  
Braved the wrath of time and seasons,  
dashing waves and fierce monsoon.  
Now its decks are slowly crumbling, all the  
vessel seems to drowse,  
And the green mould clings in patches  
underneath its arching bows.

But it brings the gifts I long for, there are  
stored within its hold  
Wealth and fame to bring me favor, com-  
fort for me when I'm old;  
For my hopes are amaranthine, and I feel  
a cheering glow  
When I think my ship is coming, where the  
trade winds lightly blow.

Soon I hope to see this vessel when the sun  
is shining clear;  
See its torn sails idly flapping as it lies  
beside the pier;  
Then I'll take my precious treasures—all  
my wealth from mystic isles,  
And thereafter life will greet me with its  
most enchanting smiles.

Though it does not make the harbor,  
though it enters not the bay,  
I am sure that it is coming, coming some-  
where, far away;  
For in reveries I see it, hear the sailors'  
merry din,  
And at night in dreams I fancy that my  
ship is coming in.

## FROM THE GAME FIELDS.

The man who quits when he gets enough, with plenty of game still in sight, is a real sportsman.

### A MINNESOTA DEER HUNT.

The 9th of November, 1902, just at sunrise, my father and I shouldered our rifles and started on our long planned deer hunt. We were bound for a loggers' camp, situated on some of our timber land, about 14 miles from Mora, Minnesota, in the heart of the deer country. I was armed with a 30-30 Savage, and father carried a 25-21 Stevens, as he is a deer hunter of the old *regime*, and was anxious to prove that arm ample for deer shooting. We arrived at camp wet and tired, but in high spirits, for we had crossed many trails and feeding grounds where deer had been the day before.

The next morning we buckled on our cartridge belts, shouldered our rifles and hit the trail. We had hunted about 2 hours when I heard the crack of the 25 on the other side of the hill. I mounted a stump, but saw nothing. Soon, however, father came tearing through the brush. He had jumped a buck, but the 25 had failed to score. We held a council of war, and decided to try a drive, so I struck out around a little swamp, but had gone only a short distance, when I caught sight of a deer on a ridge, about 400 yards distant. I shot the atmosphere all up but scored a clean miss. Father heard the shooting, came up, and we made up our minds to outgeneral the buck. I went around the hill and stationed myself on a stump, while father followed the trail, hoping to force the game past my stand. The plan was successful, for I was barely in readiness, when, high up on the ridge, I saw father mount a stump and wave his hat. Glancing down a draw, I saw the buck tearing through the brush and leaping over windfalls. My Savage was at my shoulder in an instant. As the deer cleared a log about 200 yards from me, he came into full view, and at the crack of the rifle he went down in a heap with a soft nose bullet through the neck. When we arrived on the scene he was well bled out, the bullet having cut his throat as neatly as one could with a hunting knife.

We dressed him, tied his legs together with our neckerchiefs, and strung him on a pole. Resting that on our shoulders we started back for camp. We were greeted with a shout from the cook, who came out to meet us, waving a frying pan about his head. The boys had great fun that night chaffing an old wind jammer by the name of Joe, who had said there were no deer in the country, as he had hunt-

ed the ground all over and had seen none.

It rained that night, melting all the snow; and hunting being out of the question, we started for Mora the next morning, after arranging with the lumbermen to bring in our deer.

H. L. Bliss, Mora, Minn.

### USEFUL TO CAMPERS.

725,960.—Combined Cane and Stool.  
Charles W. Heeg and Charles A. Klise, St. Louis, Mo. Filed November 10, 1902. Serial No. 130,686.

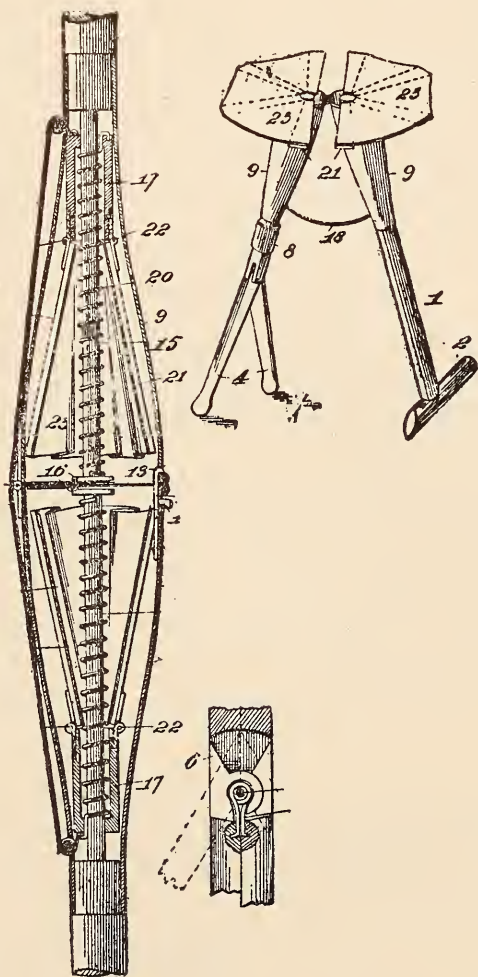

Claim.—1. The combination of a pair of pocket tubes hinged to each other, head and foot members carried by said tubes, seat-forming arms and webs, means for drawing said arms and webs into the tubes, and means for projecting the arms and webs to the exterior of said tubes.

## OLD MOSE NOT DEAD.

At least he was not yesterday morning; or if he is, his ghost made some big tracks through my pasture leading toward his old stamping grounds on Borough mountain. He was digging in an ant hill and rolling logs for bugs and not following low trails, so I let him go in peace, as his fur is not good now. It would be an unpardonable sin to kill this king of bears just to see him kick. I should feel lower than the pelt hunter.

I named Mose for a similar bear near Elyria park, bearing the ancient Hebrew name.

J. J. Pike, of Slegle, Mo., mixed things when he wrote of my "Bull Run Bear Fight," in July RECREATION. I only fired 3 shots. The first was at a cub which was left behind when the old bear ran across a small opening. I tried to shoot the old bear but only got my gun to my shoulder as she went out of sight. I then turned my fire on the cub. Afterward I ran forward until I saw the old lady going through the brush and sent 2 shots in her direction but missed. The other cub was left behind and began crying for mamma. I followed him some distance and got sight of him several times but could not get a shot, so I ran to camp for Pike and his bear (?) dog. On going back I went where I had shot at the first cub and found it shot through the head.

Pike did not see the cub until after it was dressed. He was too busy beating his dog with his gun because he would not follow the old bear trail.

Pike left out one of his hunts for the big bear. It was the time old Mose would not go into the stick houses Pike built with a steel trap in the door. Then Pike went back to Canyon City and later to Missouri.

Sam, Jr., and I got a large lion a few days ago without the help of Pike and his "Yaller dorg."

Whort, Black Mountain, Col.

## CHANGES IN ARIZONA GAME LAWS.

The Legislature, which convened early this year, made only 2 changes worthy of note in the laws passed by the Legislative Assembly of 1901.

Deer may now be shot from September 15 to December 15, making the season one month longer. The killing of does at any time is prohibited, and but 3 male deer are allowed to a hunter during the season.

The second change in the law permits the shooting of ducks and geese all the year around. Why such a law was passed is a conundrum. It is condemned by all good sportsmen throughout the Territory.

At present the boom of the shot gun and

the crack of the 22 rifle are to be heard in all directions. It is dove and Mexican pigeon shooting time, and the season on these poor birds is open the year around. They come in countless thousands from Mexico and lower California, and have been declared a nuisance by the farmers. I can not see what harm the poor doves do, as they live chiefly on wild sunflower seeds and on the seeds of what is here called "dove weed." The Mexican pigeons come from Mexico and South America, and seldom get beyond the confines of Texas, New Mexico and Arizona. They arrive here in great flocks in spring and leave in the fall. Hunters wait at water holes and creeks where, in the evening, the birds come for water, and shoot them by hundreds. The Mexican pigeon is larger than the dove and of a slate blue color, with a white stripe in the wings. Its meat is dark and tough, and it is anything but a game bird.

Formerly great numbers of quails were trapped by Mexicans and Indians and shipped out of the country. It was common, 4 or 5 years ago to see large screen cages filled with quails in front of restaurants in this city. This has been done away with and quails are now protected as they should be; consequently they are plentiful in the valleys and foothills.

J. A. T., Phoenix, Ariz.

## THE WILD LIFE OF MAINE.

Northern Maine, from Bangor to the Canadian boundary, is practically one vast forest teeming with animal life. Recently, I had the pleasure of visiting this great game country from May to December. Besides scores of deer, I saw probably 70 moose, 2 of them magnificent bulls with horns in the velvet. Caribou are now rarely seen in Maine. The majority of them have crossed into Canada, driven away, the natives say, by 'deer; an hypothesis which seems plausible, for in New Brunswick there are many caribou and but few deer. The same condition existed not many years since in Maine also. About 30 years ago, owing to excessive slaughter for their hides, moose were fast nearing extinction, but thanks to the enforcement of an excellent game law, they are, at present, holding their own.

Following is a list of the animals and birds of Maine which I had the good fortune to see: Moose, deer, black bear, red fox, beaver, otter, muskrat, mink, porcupine, woodchuck, weasel, Northern hare, cottontail, red squirrel, chipmunk, eagle, osprey, hawks of various species, barred owl, belted kingfisher, bittern, great blue heron, gull, duck, loon, spotted sandpiper, plover, ruffed and Canada grouse, pileated woodpecker, yellow-shafted flicker, blue and

Canada jays and numerous species of smaller birds.

Many theories have been advanced in regard to the drumming of grouse. I had the opportunity to study closely no less than 5 birds while they were performing the act. Standing erect on a log or rock, by a rapid motion of its wings through the air the bird produces the muffled, rumbling sound called drumming.

The greater part of my stay was at sporting camps owned and conducted by Wm. Atkins, of Oxbow, a genial host and thorough woodsman.

J. H. Fisher, Jr., Baltimore, Md.

#### HUNTING CARIBOU IN ALASKA.

The 25th of July, 1902, a native hunting friend, 2 Malamute pack dogs and I were making a 100 mile portage from Clark lake to the headwaters of the Kuskokwim river, and were within 20 miles of our destination when the native asked me if I would give him time to kill a few caribou. As I was making a hurried trip overland to the Yukon and the mosquitoes were murderous, I hesitated, and asked him how many he wanted to kill.

"Stamen" (4).

I decided to give him 2 hours in which he could kill, skin, cut up and cover that number with rocks. The caribou were feeding within  $\frac{1}{2}$  mile of us, but were scattered, and it was about the tamest shooting I ever saw. The dogs were uneasy, and it was all I could do to hold them, even with their packs on, and fight mosquitoes between times. We walked boldly up within  $\frac{1}{4}$  of a mile of the first caribou, a 2 year old buck. The native had a 30-30 Winchester, but would not shoot until he got within 150 yards. When the caribou lowered his head to feed, the native crawled up and killed the buck, a cow and a calf. Then a large buck got curious and came tacking up toward us in a zigzag course. When he was within 200 yards he went down. There was bacon on his back 4 inches thick. His horns were soft, yet full grown.

There is no excitement in hunting caribou in this section. It is just like walking into a corral and shooting cattle. The moose is far different. You earn all the moose meat you get. I had the pleasure of meeting Mr. Osgood, of Washington, D. C., and Mr. Gorman, of Portland, Ore., members of the U. S. Biological Survey. They had secured many fine specimens both of plant and animal life. L. L. Bales, Seattle, Wash.

#### "PROMINENT" LAW BREAKERS IN TROUBLE.

State Senator T. A. Willy and Willis Babb, of Appleton, Wis., are likely to be charged with violating the laws of North Dakota, Wisconsin and the United States. They have just returned from a shooting trip in North Dakota, and Game Warden Valentine Raeth, of Milwaukee, becoming suspicious of 6 pieces of baggage checked from Ellendale, N. D., to Appleton, opened one telescope, only to find it filled with plump prairie chickens. The whole outfit was seized and Warden Gerhardt sent with it to Appleton, where it was found to belong to Senator Willy and Mr. Babb. They claimed the baggage. The laws of Dakota expressly forbid the transportation of game out of the State, and the fine for each bird is \$10.

Wednesday morning Warden Raeth found a barrel of fish, marked "perch," addressed to a Chicago dealer. On being opened, the barrel proved to contain a layer or so of perch and a number of wall eyed pike. Thursday a box on a train going from Green Bay to Hartford was found by the same warden to contain deer skins. Arrests will follow these seizures.—Milwaukee, Wis., Journal.

The fine for transporting game in Wisconsin without proper marking is \$25 to \$100 or 90 days in jail and \$25 to \$100 for bringing game or fish into Wisconsin from a State where the export of same is prohibited. The penalty under the federal law for transporting game without proper marking is \$200. This will doubtless be an expensive hunting trip for these "prominent" lawbreakers.—EDITOR.

#### OF INTEREST TO TRAPPERS.

723,773.—Animal trap. Virgil O. Harter and West H. Brown, Riverside, Cal.; said Brown assignor to said Harter. Filed March 24, 1902. Serial No. 99,710. (No model.)

Claim.—1. In an animal trap, a supporting base, a tube mounted on said base, and adapted to contain a firing charge, a coiled spring engaging an aperture in the rear end of said tube by one end, a firing pin inclosed by said spring and connected by its outer end to the outer end of said spring, a trigger means disposed to support said spring distended, and a tripping mechanism adapted to release said firing pin.

2. A breech block secured on a support-rear thereof, a tube removably connected to said breech block, and adapted to support a cartridge, a coiled spring secured by one end in said aperture, a firing pin

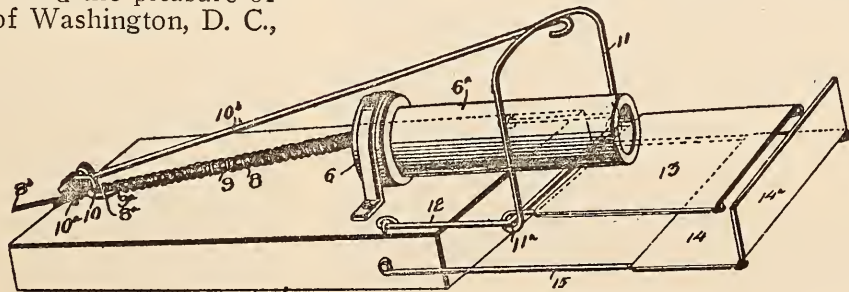

within said coiled spring and connected by its outer end to the outer end of said spring, a trigger means disposed to support said spring distended, and a tripping means adapted to release said trigger means.

#### GAME NOTES.

There will be a considerable loss of elk, but not nearly so great as we anticipated at one time, unless there is a change for the worse in weather conditions. The loss will not exceed 20 per cent and this is confined almost entirely to last spring calves and a few old cows. This loss is greatest in the lower valley, on account of a rain which caused the snow to freeze hard, so the elk could not paw through it. This rain did not reach the higher hills, leaving the snow loose, and there the elk are doing better. It is hard to see the elk starving and be powerless to help them on account of the scarcity of hay. I fed about 20 head of them with my cattle, but the elk have left for the hillsides now. Other residents have done what they could, one man feeding about 50 head for a while. All those who had haystacks had to sleep with them to keep the elk from destroying them, it being not an uncommon sight to see 500 head of elk around and on top of a haystack. There are 10,000 to 20,000 elk in the Jackson Hole country. Probably about one-third of them are in the valley, the others being scattered in the low hills surrounding the valley and on Fall river, Grosventre and Buffalo rivers, all tributaries of the Snake river.

S. N. Leek, Jackson, Wyo., Jan. 2, 1902.

I see in August RECREATION, page 152, you neglect to give our little State of Jersey credit for an anti-spring shooting law passed at the last session of our Legislature; also for the fact that, by request from Washington, doves are no longer classed with game birds, and there is no open season on them. This is an important law, as doves are getting scarce. Hon. B. P. Morris, of this place, the new president of the State Game and Fish Commission, has an efficient corps of game wardens and deputies and they are doing grand work.

Quails are plentiful and one can hear Bob White calling to his hidden mate in all directions anywhere out of town limits.

Arthur Sussman, Long Branch, N. J.

I am glad to know that New Jersey has lined up with the other progressive States in the matter of abolishing spring shooting and in protecting doves at all times of the year. I trust that within a few years we may have a solid North and a solid South against the murdering of birds in the breeding season and the killing of doves at any time.—EDITOR.

How many readers of RECREATION have encountered the loud, hot air sportsman, the owner of the only gun worth having? I rode nearly 100 miles with him recently, and when he descanted on the transcendent merits of the 38-72, box magazine, I blushed to think that I was carrying such a puerile weapon as a 30-30. He said his 38 would kill the legal allowance for his party, while my gun was fit only for squirrels. Fearing, lest he should exterminate the deer of Wisconsin, I anxiously awaited his return. I learned that he did not draw blood during his 3 weeks' stay in the woods, though his companions secured their full share of deer.

Henri Leo, Madison, Wis.

Reckless slaughter of deer and all kinds of game is going on here, in season and out. Many natives get their whole supply of meat from the woods. They kill young turkeys in July by the sackful. The Florida cracker is a cunning and vindictive fellow, and it is dangerous for a property owner to interfere with him. Game is becoming scarce, and I see little chance for its preservation.

C. R. Tarter, Estero, Fla.

Should like to hear from some sportsman who would camp with me a few weeks this fall and trap fur-bearing animals as long as the weather permits us to stay out.

There is a great deal of illegal hunting charged against the lumbermen; but I had the pleasure of spending the fall of 1900 in Pennsylvania among that class of men and I found them strict in observing the game laws.

Milton Wampole, Niagara Falls, N. Y.

#### A SUGGESTION FOR CHRISTMAS.

Have you commenced to think of Christmas presents? If so, here is a suggestion.

A yearly subscription to RECREATION furnishes one of the most delightful, instructive, entertaining Christmas presents you can possibly give a man or boy who is interested in nature, in fishing, shooting, amateur photography; or, who is fond of lakes or the rivers.

Many of the presents which people give their friends afford pleasure only for a few days, or weeks. A subscription to RECREATION means solid comfort a whole year. It reminds your friend 12 times during the year of your kindness and generosity. There are many men and women who for 5 years past have annually sent in long lists of names of friends, accompanied with a check in order that these friends might be made happy a whole year. Would it not be well for you to adopt this plan?

Try it and see how grateful the recipient will be.



## FISH AND FISHING.

### ALMANAC FOR SALT WATER FISHERMEN.

The following will be found accurate and valuable for the vicinity of New York City:

Kingfish—Barb, Sea-Mink, Whiting. June to September. Haunts: The surf and deep channels of strong tide streams. Baits: Blood worms, shedder crabs and beach crustaceans. Time and tide: Flood, early morning.

Plaice—Fluke, Turbot, Flounder. May 15 to November 30. Haunts: The surf, mouth of tidal streams. Baits: Shedder crabs, killi-fish, sand laut. Time and tide: Ebb, daytime exclusively.

Spanish mackerel—Haunts: The open sea, July to September. Baits: Menhaden, trolling—metal and cedar squids.

Striped Bass—Rock Fish, Green Head. April to November. Haunts: The surf, bays, estuaries and tidal streams. Baits: Blood worms, shedder crabs, Calico crabs, small eels, menhaden. Time and tide. Night, half flood to flood, to half ebb.

The Drums, Red and Black. June to November. Haunts: The surf and mouths of large bays. Bait: Skinner crab. Time and tide: Day, flood.

Blackfish—Tautog, April to November. Haunts: Surf, vicinity of piling and old wrecks in bays. Baits: Sand worm, blood worm, shedder crabs, clams. Time and tide: Daytime, flood.

Lafayette—Spot, Goody, Cape May Goody. August to October. Haunts: Channels of tidal streams. Baits: Shedder crabs, sand worms, clams. Time and Tide: Day and night flood.

Croker—July to October. Haunts: Deep channels of bays. Baits: Shedder crabs, mussels. Time and tide: Day, flood.

Snapper—Young of Blue Fish. August to November. Haunts: Rivers and all tide ways. Baits: Spearing and menhaden; trolling pearl squid. Time and tide: Day, all tides.

Sheepshead—June to October. Haunts: Surf and bays, vicinity of old wrecks. Baits: Clams, mussels, shedder crabs. Time and tide: Day, flood only.

New England Whiting—Winter Weak-fish, Frost-fish. November to May. Haunts: The surf. Baits: Sand laut, spearing. Time and tide: Night, flood.

Hake—Ling. October to June. Haunts: Open sea surf, large bays. Baits: Clams, mussels, fish. Time and tide: Day and night, flood.

Weak-fish—Squeteague, Squit. June to October. Haunts: Surf, all tideways. Baits: Shedder crabs, surf mullet, menhaden, ledge mussels, sand laut, shrimp. Time and tide: Day and night, flood preferred.

Blue Fish—Horse Mackerel. June to November 1st. Haunts: Surf, open sea and large bays. Baits: Menhaden, surf mullet and trolling squid. Time and tide: Daytime; not affected by tides.

### PRIVATE TROUT STREAMS.

Sheriff E. J. Tallman has appointed Willard Brown as special deputy sheriff to look after and protect the lands of Milo L., Merritt A. and Stephen R. Cleveland. This is for the purpose of restraining fishermen from angling in that part of Cold creek which runs through the Gifford and Gotham farms, recently purchased by the Cleveland brothers.

Above clipping refers to a small trout stream which runs almost its entire course through pasture lands recently bought by the Clevelands. This creek has for years been regularly stocked with trout from the New York State hatcheries, the consent of the old owners having been obtained.

We who have worked to keep our

streams supplied with trout had understood that waters once stocked with State fish could not be controlled by club or individual and that all had an equal right to fish. If the Messrs. Cleveland are acting within their rights, then all farmers can do the same, and we poor mortals are "not in it." Will you be good enough to advise whether you know of a remedy?

Harvey R. Waite, Watertown, N. Y.

### ANSWER.

The question you raise is a serious one and is constantly being confronted and discussed all over the country. My sympathies are usually with the under dog, provided he is a good dog, and so my sympathies are with the man who does not own land through which a trout stream runs. At the same time I am compelled to recognize the right of eminent domain which has existed in all countries for hundreds of years past. If a man owns a farm or even a plot of ground 10 feet square he has a right to control it and to forbid persons walking across it whom he does not wish to have do so. If you own a town lot and should plant a garden on it you would not want Tom, Dick or Harry to help themselves to your onions, radishes, beets, or whatever else you might happen to raise there. If either of these fellows undertook to do so you would doubtless forbid him, and then, should he persist, you would resort to your right of ownership and call in an officer to put either Tom or Dick or Harry, whichever it might be, into the cooler. So if you owned a farm and had some fish or some birds on it which you wanted to keep for your own use you would not want a gang of dagoes, or any other kind of gang, to come out from town Sunday, overrun your property and kill your game or catch your fish.

The Cleveland brothers certainly have a monopoly of the stream, and I trust no law may ever be enacted in this country to deprive them or other land owners of their just rights or privileges. Each State should provide ample playgrounds for its citizens. New York should own thousands of miles of trout streams which should be regularly stocked and in which residents of the State should be allowed to fish under proper regulations. Such provisions are gradually being made for the people of various States, and I hope the good work may continue.

—EDITOR.

### THE SHAD AND ITS HABITS.

Does the shad inhabit salt water and run

up rivers to spawn? Is it in any sense of the word a fresh water fish?

N. H. Fowler, Columbus, O.

ANSWER.

The shad is not a fresh water fish, but an anadromous fish; that is, a fish which lives and feeds habitually in salt water and comes into fresh water only at spawning time and for spawning purposes.

Three species of shad are known in American waters:

The common shad, *Alosa sapidissima* (Wilson), which occurs along our Atlantic coast from the Gulf of St. Lawrence to Florida, entering all suitable rivers at spawning time and returning again to the sea when done spawning;

The Alabama shad, *Alosa alabamæ* (Jordan & Evermann), known only from the Gulf of Mexico, streams tributary to which it enters at spawning time;

The Ohio shad, *Alosa ohioensis* (Evermann), thus far known only from the Ohio river, in which stream the fish was recently discovered. Though this species has not as yet been seen in the Gulf of Mexico, there is every reason to believe that it belongs in salt water and comes up the Mississippi to the Ohio at spawning time. It is of some commercial importance at Louisville, Ky., where it is caught in haul seines, light leaved so as to fish the surface.

The only shad of great commercial importance is the common shad of the Atlantic coast. The principal shad fisheries are in the lower portions of the Potomac, Susquehanna, Delaware, Hudson, Connecticut and St. Johns rivers and in the rivers of the South Atlantic States. The fishing season begins earliest in the South and has reached its height in the Northern rivers in late April, May and June. The catch is enormous and amounts to about \$2,000,000 annually.

This species has been introduced on the Pacific coast, where it did not previously occur, by the United States Fish Commission. The waters were found congenial, the shad thrived, and now the catch of shad on the West coast amounts to half a million dollars annually, an amount exceeding the entire expense of conducting the United States Fish Commission. This is one of the best proofs of the value of the artificial propagation of food and game fishes.—B. W. E.

GOOD BASS FISHING.

Last September I took a little fishing jaunt along the head waters of the Genesee river. This is not usually considered an attractive fishing ground, but there is many a small mouth black bass in these waters that will give the most ardent angler all the

excitement he cares to have; and the dexterity in casting, watchfulness and skill required in landing a fish in the snaggy, rocky holes in which they are found, together with the rough tramping and wading, afford much pleasure to the angler who cares more for overcoming obstacles and obtaining results under difficulties than for killing a big string of fish. I have fished in these waters several years, and have heretofore been using a rod manufactured by an old angler of the locality who has caught black bass out of the Genesee river ever since he was able to hold a rod. He with many others in the region, believes that the proper rod for bass should be 14 to 16 feet long, and heavy enough to lift the biggest fish out of the water before it has a chance to run. This summer I shattered all precedents by taking with me a Bristol steel rod, No. 8, and a Yawman & Erbe automatic reel. I was told that an old settler, as the large bass are called there, would simply jerk my tin pole inside out, and that the automatic reel would never have any effect on one of them until he was safely hidden behind his favorite log or stone. While I did not have an opportunity to test the rod on as large fish as there are in those waters, both the rod and the reel justified their reputation. They also have the added advantage of far less weight and far greater convenience. Bass in all the streams of Southern New York are unusually fat this year. There is an enormous number of fry and minnows in all the streams.

L. B. Elliott, Rochester, N. Y.

AT MOOSEHEAD LAKE.

The early part of last September I spent at Moosehead, Me., on the line of the Canadian Pacific Railway. The fishing there is remarkable. The station is at the outlet of the Kennebec river from Moosehead lake, and brook trout can be caught from the dam, as well as all along the rapids. The regular thing last fall was for anglers to catch half a dozen trout before breakfast and have them cooked for that meal. Men who have been going to Moosehead every season for 30 years were there again, fishing as enthusiastically as boys. One old gentleman who apparently had rheumatism to such an extent that he had to be assisted in walking, was each morning conducted out on to the dam, where he often sat nearly all day, happy as a king, and catching all the trout he could use. The live rapids roaring between dense evergreen woods, the broad lake stretching back to the Spencer mountains without sign of habitation, give the place absolute wildness, so dear to the heart. One angler was reported to have caught 100 brook trout in a

day, but to have returned to the water all but the largest.

Numbers of deer were seen near. Almost every evening 2 deer came to feed at the edge of the woods, where we could plainly see them from the house. One of these was an albino buck, pure white, save for a small patch of brown on his face. The law protected him at that time, but now that the season is open this beautiful, confiding creature will probably be killed by some brute who cares more to gratify his silly vanity by the possession of an unusual trophy than he does for one of nature's most beautiful animals.

B. S. S. B., New York City.

---

NIBBLES.

What is the best way of catching yellow pike in a small lake?

Frank Bloss, Silver Springs, N. Y.

ANSWER.

The habits of the yellow pike vary with different waters. In small lakes they can sometimes be taken by trolling at the surface with a live minnow, Skinner spoon, or any good trolling spoon. I have occasionally taken them with bucktail. They are most apt to strike during April and May. In the summer they do not bite so well, but now and then late in the evening they will take the spoon. The best time is in late September and October. Then you should troll with a good sized live minnow. Have your line heavy leaded, so the minnow will be near the bottom. I have had success trolling thus in water 30 to 40 feet deep. In lieu of a live minnow 4 or 5 small silvery minnows put on in a bunch will do well.—B. W. E.

---

Game Protector Vosburgh, of Saranac lake, by clever work captured a gill net 100 feet long in lake Clear a week ago Sunday night. He succeeded in getting it after hours of hard trolling, the net being off what is known as Burnt point. It had evidently been set only a short time, there being only 14 trout in it. After throwing the trout back into the lake, Vosburgh took the net ashore and destroyed it. On returning home Monday he met on the train Henry Davis and Thomas Peacock, of Saranac lake. The actions of the men aroused Vosburgh's suspicions and called his attention to the contents of a pack basket they had in their possession. He seized it and found tucked away in the bottom of it 5 lake trout. For having them in their possession Justice McIntyre fined Davis and Peacock, jointly, \$100 and costs, which they paid. It is well to remember that lake trout must not be taken until May 1.—The Malone Farmer.

Mr. Vosburgh has shown commendable courage and spirit in this case, as in many others he has handled, and has earned the thanks of every sportsman.—EDITOR.

---

I am out with a surveying party, encamped on the banks of the Columbia river.

I have tried every evening to catch fish, so far without success, though I have a green-heart fly rod and the finest tackle that can be bought. Have tried 125 different flies and many kinds of grubs. The water is muddy and cold from melting snow. Does that make any difference?

H. W. Turner, Arrowhead, B. C.

ANSWER.

You will probably be able to get trout a little later, after the water clears a bit; but the river is not the best place for trout. I advise trying the lakes and smaller streams. You ought to find excellent fishing in the smaller lakes of that region.—EDITOR.

---

Mr. G. O. Shields,

Publisher of RECREATION, New York.

Dear Sir: At a recent meeting of the Anglers' Association of Onondaga, you were, in recognition of your manifold services to the cause of fish, game and forest protection, elected to honorary membership therein.

Truly yours,  
J. E. Bierhardt, Secretary.

I am deeply grateful to the members of the Association for this honor and only regret that I could not have done more to deserve it.—EDITOR.

---

Fred Neilson, of Weathersfield, with 2 Claremont people, went fishing Sunday and caught 89 trout, 81 of which were less than 6 inches long, according to fish warden Streeter's measure. Having to face a trial, Neilson appeared before Justice M. L. Lawrence, Monday, waived examination, pleaded guilty, and was fined \$20 and costs of \$5.36.—Springfield, Vt., Reporter.

It is to be regretted Justice Lawrence should have let Neilson off so lightly. His fine should have been \$100. Neilson's number in the corral is 909.—EDITOR.

---

Last May I visited Indian river, in the Adirondacks, I found fishing good there and brought back nearly 10 pounds of trout. I could have caught 3 or 4 times as many with no trouble at all. The trout were running small and more than half the number I took I returned to the water on account of their being undersized.

Ira L. Park, Holland Patent, N. Y.

In answer to A. R. Prettyman, I will say that the carp, though a good fighter, is not a table fish. While small he is quick, but as he grows he gains in strength but becomes lazy.

D. M. E., Kankakee, Ill.

---

I fished in Wakatomica creek, July 4, and caught a white salmon, 27½ inches long, weight 4 pounds 10 ounces. I landed him with a No. 12 Bristol rod.

Frank Horn, Columbus, O.

## GUNS AND AMMUNITION.

Anybody can shoot all day, but a gentleman will quit when he gets enough.

### DEFENDS THE REPEATER.

I feel it my duty to answer Double Barrel. I can not understand why so many men think all others who do not think and feel as they do in regard to any subject are fools; or, to say the least, are mistaken. Every man has a right to his opinion, though frequently it is well to keep it to himself. If Double Barrel thinks his style of gun superior in every way to the pump gun, well and good. He writes as if he did not exactly understand his subject, and possibly he never used a pump gun. If so, he is the first man, to my knowledge, to speak evil of them. Mine is a Winchester brush gun, 26-inch barrel, full choke, and it is the best I ever shot, although I have used most of the standard makes of this country. It is not a first class bird gun, as it shoots too close, but for ducks and all around shooting it is good. A score or more of game hogs in my county all use double guns. Of course the gun has nothing to do with making hogs of them. Harm can come from any custom or instrument used and made to promote the comfort and welfare of man; but how they can or will be used depends on the man. If Double Barrel thinks the pump gun man can exterminate a covey of birds when they rise, let him try it some day. In using black powder I seldom get more than 2 shots on the rise; with smokeless, 3 or 4. I always pick my birds and never fire into the covey. Frequently I have killed 3 birds on the rise; once I got 4, wounding one. If possible, I shoot at one bird until it is dead or out of range. A sportsman always lets his bird get at least 20 yards distant before firing. Then they are soon out of range, and only with smokeless powder is it possible to get more than 2 shots. When Double Barrel says we fire 5 to 6 times on the rise and kill 2-3 of our birds, it may sound easy, but is impossible.

As to the automatic gun, I do not see how it could be of any value, for of what use is it to fire without aiming? For instance, fire at a flock of blackbirds, and frequently one will get 2 or 3 birds. Had 1-10 of the shots fired in the civil war taken effect, no men would have been left on either side.

Pump Gun, Dublin, Va.

An article in RECREATION, headed "Condemns the Repeating Shot Gun," is a good story, but the writer should have put in a few facts. He is evidently a game hog and is afraid someone will kill more birds than

he does. If he will carefully investigate he will find there are more game hogs using double guns than repeaters. If Double Barrel is in for game protection, why does he condemn the gun which most game hogs use and then go after the repeater? If the present laws can not be enforced, how can he expect to enforce a law prohibiting the use of certain guns? Most States have more laws now than they can enforce properly. If a man wants to be a hog he will be one, no matter what kind of a gun he carries, or if a man wants to be a sportsman he will be one, if he has a gun that never stops shooting.

Double Barrel says you can buy a good gun from \$16 to \$25. True; but, for close, hard shooting they are not in it with a repeater, which is made to shoot hard and close. A game hog wants something that he can point at a flock of birds, pull the trigger and get the whole bunch. That is probably why most of the game hogs use double barrels. A man with a repeater does well if he gets 2 birds the first 2 shots, and when he shoots the 3d time the birds are out of reach. When a bird is hit by a shot from a repeater it is your bird. A repeater does not, as Double Barrel says, make more wounded birds than could possibly be made with a double barrel.

Last fall B. S. and I went for a duck hunt. One rowed the boat until the other got a shot at ducks and then we changed places. During our trip of 2 days we killed 7 ducks. I killed one of his that would have got away, as it was out of his reach. Twice he brought down 2, one getting away each time. I had none get away and only brought down one at a time.

Repeater, Vicksburg, Mich.

### ROBIN HOOD POWDER.

Answering A. W. Crampton, in April RECREATION, regarding Robin Hood smokeless: My experience with that powder has not been altogether satisfactory. Have used it 2 seasons, shooting Lafin & Rand and Robin Hood alternately. Robin Hood makes entirely too much smoke, especially on a damp day. It should, in my estimation, be called a semi-smokeless powder. With a little wind on a clear day the smoke is not so noticeable. I usually load my own shells for duck shooting. Have used Robin Hood in that way, also in factory loaded shells. The shell made by the Robin Hood people is about as poor as any I have ever seen, both as to quality and loading. The brass base is of inferior quality and

the crimp is bulged so as to make the shell stick in chamber of barrel.

I have had excellent results with Lafflin & Rand loaded in U. M. C. shells. If Mr. Crampton will buy L. & R., loaded according to directions on can, he will get good results if he has a good gun. It has greater penetration than Robin Hood, and it will keep 12 months without losing its strength.

Last winter I shot a goose on the wing, at 45 yards, with L. & R. and No. 3 shot, 4 or 5 shot going clear through the bird. I use a 10-gauge, 30-inch Ithaca, and load 50 grains L. & R. and  $1\frac{1}{4}$  ounces No. 3 shot for duck shooting. Should like to hear the experience of others with Robin Hood powder; also how L. & R. compares with Walsrode.

Chas. H. Bentley, Hampton, Va.

In April RECREATION A. W. Crampton asks if Robin Hood shells are as good as U. M. C. or Winchesters. Last fall I tried one box. Out of 25 shells 9 split nearly the entire length, and the heads blew off of 3 others. Taking it all around, I prefer the U. M. C. smokeless. Have also had trouble with Peters shells when firing them in a Winchester shot gun. Have known them to split and send part of the case half way through the barrel, besides blackening the remaining shells in the magazine.

In answer to A. B. Turf, will say I have been using Winchester and U. M. C. shells loaded with nearly all kinds of smokeless powder. Have had no trouble so far, and my gun barrel is as bright as a new dollar. The gun is a single, 12-gauge Davenport, with barrel cut down to 26 inches.

H. B. W., Rockland, Me.

Answering A. W. Crampton, St. Albans, Vt. I have used Robin Hood smokeless powder since it was first put on the market in this Province and have found it all one can wish for. I have had loaded shells laid by 18 months and as good when used as when first loaded. It is not affected by changes of temperature within reasonable limits. It can be loaded in the same way as black powder and in the same shells. I have always used it in Kynock's Perfect brass shells and find it better than the best black powder.

Chas. E. Poeriti, Treherne, Manitoba.

In answer to A. W. Crampton's question, would say that in 20 years' experience with various brands of powder I have found none so satisfactory as Robin Hood. It is the quickest, strongest and cleanest powder made. My favorite load for bird shooting, using a 7 pound, 12 gauge gun, is 3 drams Robin Hood and  $1\frac{1}{2}$  ounces No. 7 shot.

J. W. Calkins, Putnam Sta., N. Y.

#### THE IDEAL GUN.

To my mind the ideal gun is one that meets the requirements of a sportsman going after a certain class of game, and no single gun was ever built, or ever will be, that is equally satisfactory for all kinds of shooting; therefore, in order to obtain best results it is necessary to choose the gun best adapted to the game we expect to hunt.

For small game like rabbits, squirrels, birds, etc. I suggest the 22 caliber rifle. It is accurate up to 100 yards and does not spoil meat as a large bullet would. It is necessary to keep this gun thoroughly clean, otherwise its accuracy will be impaired. For deer, my choice would be either a 30-30, .303 or the 32 Special. Provided with a Savage or Winchester rifle of any of these calibers, the hunter possesses a light, strong and exceedingly accurate piece, and if he is a skillful marksman it is rarely, indeed, that he will lose his game by wounding and not killing. I have hunted with a friend the past 4 years who has never missed killing his deer with a single shot from a 30-30. Any man who will practice target shooting occasionally, and not develop an attack of buck fever every time he draws a bead on an animal, may make as good a score.

For bear, moose, elk and caribou, the great majority of which are killed within 200 yards, my preference would be either a 30-40, 33, 35-40 or 45-70. They have terrific shocking and penetrating power and this is an absolute necessity where one hopes to secure a trophy after finding it. The power of endurance in this class of game, even after receiving a mortal wound, is simply marvellous. Unless the hunter has inflicted a severe injury with his first shot, the chances are in favor of the animal's escaping, and this, I claim, is much more frequently seen when using a smaller caliber.

Each year finds experienced hunters gradually discarding the 30-30 for game larger than deer. Few experienced men would, if armed with a 30-30, be willing to take chances with a grizzly, and for one who is not experienced it would be almost suicidal. I do not claim that a 30-30 is incapable of killing animals of this size, but for the ordinary hunter the larger caliber is to be preferred.

I emphasize the wisdom of following the instructions given by the manufacturers of arms, especially as to the ammunition used. It is of interest to these people to give the hunter the best possible goods, and when they recommend a certain class of ammunition for certain guns it should, in justice to them and to ourselves, be used. As yet I have never seen either a Savage or Winchester jam if the proper cartridge was used and the gun kept clean,

The man who can afford to buy but one gun and expects to shoot any kind of big game should get a rifle of either 33 or 35-40 caliber. The former is a particularly handy gun for hunting, being light. Made in take down style, with a 24 inch barrel, it can be readily packed. It is almost as powerful as the 30-40 or .303 British and the fact of its being a larger caliber is a decided advantage in its favor.

James C. Stirk, M. D., Oakland, Cal.

#### SMOKELESS IN BLACK POWDER GUN.

I note B. L. Dingley's inquiry in regard to using the smokeless shot gun powders in an old black powder gun. I have been doing just this thing the last 6 months and in an experiment charge have used 28 grains Laflin & Rand's Infalible and 1 $\frac{3}{8}$  ounces chilled shot with no ill effects. My gun is a Parker hammer gun. I have used it 10 years, so I judge it was made for black powder. It has ordinary stub twist barrels and was a \$60 grade, I think. The manufacturers could give us the facts about the strength of the black powder guns if they would, but, of course, it is to their interest to create a feeling of doubt when this question came up. In reloading 32-20 rifle shells with a dense powder to be used in a repeating gun instead of indenting the brass shell to prevent the bullet from dropping back on the powder I have enlarged my Ideal bullet mould so that when the bullet is pressed home by the reloading tool the brass shell is crimped into the lead. This prevents the bullet from dropping back.

Dr. C. D. Crooks, Philadelphia, Pa.

May RECREATION contains an inquiry from B. L. Dingley, Meadville, Pa., as to the safety of using nitro powder in a laminated steel gun made 10 or 12 years ago. I have a Westley Richards, side lever gun that is over 20 years old, and am using heavy charges of nitro powder in it. With U. M. C. Arrow and Nitro Club, and Winchester Leader shells it shoots to perfection and shows no sign of becoming loose. Barrels are laminated steel.

In my opinion the 32 Special is the best all purpose rifle on the market. The black powder load is all right for deer and smaller game, while the high power cartridge should be ideal for big game.

W. S. Mitchell, Easby, N. D.

Will say to B. L. Dingley that if the barrels of his gun are smooth and bright inside, he can use reasonable loads of nitro powder with safety.

Double hammer guns of to-day, costing \$12 to \$20 are, if taken care of, as safe with nitro powder as more expensive ones. I have a double machine made gun, bought in '98, in which I have shot hundreds of

black powder loads. The past 2 years I have used nitro only, and the gun is as tight and bright as when it left the shop. Do not use nitro powder in a dirty gun unless you are tired of life.

W. C. H., Augusta, Mich.

B. L. Dingley, Meadville, Pa., does not say whether his gun is hammer or hammerless. If this is a hammer gun and is not fitted with nitro firing pins, I advise him not to use nitro powder. Gas escapes back of the shell and passes out around the firing pin and might injure the eyes.

W. E. Brown, Seneca Falls, N. Y.

#### TO LOAD BUCKSHOT.

Will Mr. Lang or some other reader of RECREATION tell how to load buck shot for deer. My gun is an Ithaca, 10 gauge, choked. What size shot should be used? Would chilled shot be better than soft and is there any danger of bulging the gun at the muzzle?

For long range duck shooting with this gun will DuPont's Choke Bore or Eagle duck powder give better results than DuPont nitro or factory loads of black powder?

J. B. Scott, Benton Harbor, Mich.

#### ANSWER.

The following instructions, reprinted from a former issue of RECREATION will doubtless give the information you wish:

First, select buckshot of a size that will chamber at the muzzle of the gun. This will depend on the choke and the gauge. If shot about 3-10 of an inch in diameter are used, 4 will chamber in a 10 gauge and 3 in a 12 gauge gun. Three layers are enough for a load. This makes a 10 gauge load contain 12, and a 12 gauge load 9 shot, respectively. For distances under 60 yards good results may be obtained by loading the shot in layers packed in sawdust, to make them stay in place while passing through the barrel. Each layer should be packed separately and carefully. A card wad should be placed on top and the shell crimped as usual.

For a 10 gauge take a short piece of 12 gauge paper shell and put a card wad in one end to form a cup, or case. Then load the buck shot in this as described above and place this case in the cartridge so that case and all will be discharged from the gun. If the case be made up with a wad placed over all, in the cartridge, it will generally fly like a ball up to 100 yards, and will bore a  $\frac{7}{8}$  inch hole through the target. Sometimes one or 2 shot will escape and be found a few inches from the large hole.

To make the shot scatter more put no wad in the top of the case, but put a card wad in the cartridge over the case. **By this**

method of loading, I put 8 out of 9 buck shot inside a 30 inch circle at 60 yards.

For a 12 gauge gun a smaller case and smaller buck shot would be needed, but no case should be used which can not be pressed through the muzzle of the gun. Such a load will do terrible execution at ranges within 100 yards, and with it a man need not fear to face even a bear.

You should never hunt deer with a shot gun. It is not a sportsmanlike method.

I advise you to write E. I. DuPont, De Nemours & Co., Wilmington, Del., for the information you desire regarding their powder. It is a technical question that I would rather not answer.—EDITOR.

#### MORE ABOUT WOODCHUCK SHOOTING!

More than a quarter of a century ago I earned the name of Woodchuck at college and I have spent many pleasant hours trying to bag the chuck. During the past season I got 41 out of about 60 shots, my best success being with the 32 Ideal cartridge. I regard this cartridge as nearly equal in accuracy, up to 200 yards, to the 32-40 and 38-55. The trajectory is less flat. Anyone anxious to stop a woodchuck above ground will not often try a shot at a distance greater than 100 yards. My 32 Ideal is mounted with a Duplex telescope. In using this rifle, many of the shots being off hand, I secure about 80 per cent. of the chucks shot at. Last season I did by far the greater part of my woodchuck shooting with a Stevens' Favorite, 25 rim fire. I used a telescope, but lost nearly all chucks I shot at beyond 60 yards. The cartridge is too heavy for a 4½ pound rifle. In a 7¼ pound Stevens I found it equal to the 22 long rifle, but for woodchucks it is no better than the 22 long rifle; for neither bullet will stop the chuck unless sent through head or neck. A Stevens Favorite, provided with telescope and 22 long rifle cartridge, will bag more than 75 per cent. at 60 yards. I have used one several seasons until last year, when I tried the .25 caliber with poor success. Whatever rifle one uses let him, if he can possibly afford it, have it mounted with a telescope. He will get many shots, when without it he would be unable to see any portion of the chuck as it looks through brakes or bushes or just shows its eye above some rock or root. The pleasure of being able to see distinctly every movement of the wary fellow while he thinks he is effectively hiding, is equal to that of bowling him over with a well placed bullet. Then the telescope saves many steps, showing at once what the distant brown bunch is.

For the rest split with a saw the handle of an old broom or rake, 4 inches from one end and rivet the 2 parts together with

a single rivet. They will then open and close like the blades of scissors. Sharpen the points farthest from the rivet. When closed, this rest is as easily carried as a cane and it can be instantly opened and adjusted as a muzzle rest for the rifle, the shooter either kneeling, sitting or lying down.

T. C. H. Bouton, Henniker, N. H.

#### LIKES A LONG RIFLE.

I have a 25-25 Stevens Ideal, No. 45 rifle, 12 inch twist, 24 inches long. It is too short for fine target shooting, as most of the target rifles around here have 30 inch barrels. We have all heard of the long muzzle loaders our granddads used, and it must be conceded they did good shooting with them. I came across one the other day and took some measurements. The barrel was 38 caliber and 38 inches long. That set me thinking. The longer barrel was a longer guide to start the bullet on its accurate flight.

Nearly all the shooting I have done has been at a 100 yard range. I tried the other rifles that come to the range, 25-20, 25-21, 32-40 and 38-55. I read carefully the catalogues of gunmakers and devoured eagerly all RECREATION had to say on the subject. I decided that the Ideal No. 49 Stevens 28 caliber, 32 barrel, weight 11 pounds, is what I want and ordered one. It came, but I have not had the pleasure of trying it yet, nor will I have for some time, as I am laid up with powder burns on face and left hand as result of taking the powder out of some old rim fire cartridges for an army carbine.

I wanted to keep 4 of these obsolete cartridges with a collection of modern cartridges which I had gathered to compare lengths, shape, bullets, etc. A friend saw the collection and suggested that I ought to take the powder out of them to guard against accident. To empty the cartridges I drilled a ⅛ inch hole about ⅛ inch from the head of the shell and with a pin worked all the powder out, catching it in a baking powder can. The last shell struck fire after I had about all the powder out and ignited the contents of the can. The burns are not serious, but I shall be laid up a while. I have been handling arms and ammunition nearly 30 years and this is my first accident.

I love target shooting, but take no pleasure in killing game of any kind. We use ring targets with 6 inch bull, rings ¾ inch apart, counting 25 at center to 10 at outside, which is 12 inches in diameter. We also have an indoor range for .22 caliber rifles only. The distance is 60 feet. Targets same style on reduced scale, bull 1½ inches, rings ¼ inch apart, 25 at center to 20 at outside.

Robt. A. Whistler, Wilkinsburg, Pa.

## REPLIES TO MR. GOSS.

I use a Winchester 16 gauge gun with 28 inch modified choke. In this gun I find a Leader shell, loaded with  $2\frac{3}{4}$  drams of bulk smokeless powder, one 16 gauge filled or trap wad, 2 15 gauge black edge wads, and  $\frac{7}{8}$  ounce No. 5 chilled shot, with a thin shot wad and good round crimp, all one could desire for either squirrels or ducks. Three drams of powder and one ounce of shot shoots a trifle harder, but there is considerable increase in recoil and really no gain, as the pattern is more broken.

My advice to Mr. Goss is to pattern his gun with Nos. 4, 5, and 6 shot at 35 yards, and settle on the size it handles best. It has been my experience that a full choke 12 or 16 gauge gun makes a better pattern with No. 5 shot than with 4 or 6.

As to powders I have used DuPont, Hazard and Laflin & Rand and have found them good. Laflin & Rand has given good satisfaction when loaded 22 grains in Leader  $\frac{3}{4}$  base shell, wadded and shotted as above.

In JUNE RECREATION J. B. Knapp says he can kill farther with black than with smokeless powders. I have used thousands of loads of both and have often thought good black powder, when properly loaded, gave the longer range, especially when shooting heavy shot. However, the pleasure in shooting smokeless so overcomes the slight difference that I prefer it by odds.

Many make the mistake of ramming or putting too much pressure on nitro powder. Just seat the wads firmly and you will get better penetration as well as pattern and less recoil. If you prefer black powder and want a good killing 16 gauge load, use a  $2\frac{3}{4}$  inch black powder shell and  $2\frac{3}{4}$  or 3 drams of DuPont Eagle ducking powder. This powder costs more than many other grades, but is clean and has great penetration. The medium grain is best for field or timber, as the coarse grain burns slower.

Jack, Guthrie, I. T.

## BUCKSHOT IN CHOKE BORES.

You may tell Buck Shot, of Milner, N. D., that if he will use a cylinder bored gun and Nos. 6 or 8 shot, and cut the shell between the powder and wads, he will get better results than from using a choke bore with buck shot. I have experimented along this line for years and got better results from small shot and smokeless powder, loosely loaded but with a good crimp, than when using large shot and black powder. I use a double gun. The cylinder bored barrel will, up to 125 yards, shoot a cut shell equal to a rifle. I have time and again put a whole charge of Nos. 8 or 6 shot 2 inches into a sycamore or cottonwood tree at 100 steps. I have never used this load on anything larger than jack rabbits and wolves;

but on them it was fatal and they dropped on the spot where they were shot. I believe that on larger game it would be equally effectual.

D. O. Bosley, Wapanucka, I. T.

In answer to the question asked by Buckshot, Milnor, N. Dak., regarding the use of buck shot in choke bore guns, would say I have used a load composed of 3 drams powder, well wadded, with 3 buck shot that chamber loosely in a shell, with a card wad to cover, and found it excellent for fox shooting at long range. The result might be different in using different guns. Have used several sizes and makes of rifles and find that the 32-40, '94 model, Winchester suits my purpose as well as any. It is light, positive in action, and an accurate shooter. Made with half length magazine and half octagon barrel it is a well balanced arm.

Milton Wampole, Niagara Falls, N. Y.

In JUNE RECREATION Buck Shot, Milner, N. Dak., tells of cutting a shell in order to bunch the charge for long distance shots. I have heard of this being done but have never succeeded in doing it. I should like to know whether the shell is cut lengthwise or around. Will gladly send stamps to anyone who will cut a shell properly and send it to me.

Edward Hallowell, Phila., Pa.

## ANSWER.

The shell should be cut around and between the 2 wads on top of powder. Cut the shell clear through about half way around and nearly through in the other part.—EDITOR.

## DENOUNCES THE PUMP GUN.

In JUNE RECREATION Black Jack replies to statements made by Double Barrel anent the pump gun. I do not say Winchester, because there are others, and they are all just pump guns.

Black Jack says it is impossible to deliver, effectively, more than 2 shots into a covey of flying birds when using a repeater. This might be true if the birds always got up at 30 to 35 yards rise, and altogether. But every real sportsman knows that chickens and quails frequently flush at a distance of only a few feet from the hunter, and just as often spring up singly or in pairs; and it is for such situations the murderous repeater is designed and used.

Black Jack further informs us that the repeater is a close-shooting, durable gun at a reasonable price." I can buy a double gun which will give as good, or better, pattern and penetration and wear longer, at a much more reasonable price. There is not less iron in a pump than in a double-barrel "of equal strength." A careful user of firearms will be apt to smile when he is told



that a gun, the magazine of which is filled with cartridges, is a perfectly safe weapon to leave standing around. Our friend also declares that the "No. 12" (repeater, I suppose), is not an ideal gun for a game hog. Here, at least, no one will say him nay. The game hog has not yet found his ideal weapon; but the repeating shot gun comes as near it as he is likely to get for some-time.

Black Jack assures us in effect, that the men who used, or are using, the muzzle loader were or are the only game butchers. One scarcely knows whether to laugh at such a statement and let it pass or to take it seriously and nail it for what it is.

I might be tempted to dilate on this pump gun question, but on page 442 of the June number, there is a picture which saves me the trouble. Well and truly does it portray Bristly Buffaloes or The Power of the Pump.

Green Heart, Astoria, N. Y.

#### DRIFT OF PROJECTILES.

Six or 7 years ago there appeared in RECREATION an article, with diagrams, about the drift of a bullet. I am not a believer in drift, but it is an interesting subject, and I should like to see it thoroughly discussed. If there is truth in the theory I should like to know it, but if there is not let us put it away forever.

According to the diagrams accompanying the article mentioned, a projectile flies with its axis at an acute angle to its line of trajectory. If that were the case it would key-hole when striking. It is my opinion that a bullet flies point on throughout its course, and in this position the air is more dense under its point than it is on top.

Al. Kennedy, Post Falls, Idaho.

#### ANSWER.

The drift of a projectile revolving on an axis parallel to the initial direction of its flight is now an acknowledged fact and has been definitely determined in a great many cases. A full discussion of drift, by Professor Bashforth, can be found in any large library. To understand Professor Bashforth's discussion the reader must have an elementary knowledge of physics and mathematics. The angle of the axis of an elongated projectile (conical bullet) with its line of flight would be so small at ordinary sporting distance, to which your observation is probably limited, and even at a distance of 1,000 yards, that the eye could not detect any indication of keyholing. This, however, is no argument against the existence of drift.

You might just as well say you do not believe the earth revolves as to say, in this 20th century, that you do not believe a bullet

drifts because you can see no tangible evidence of it.—EDITOR.

#### ANSWER TO BLACK JACK.

In JUNE RECREATION is a letter from Black Jack, of Hopkins, Okla., in which he condemns the article on the Winchester in the December issue. He says, "In practice he will find that by the time he has fired the second shot from a pump gun at flying birds, they will have moved out of range." This may be true of the man unaccustomed to the Winchester slide or of one who uses a lever action. With a slide action, by keeping a constant pull on the slide when brought to the shoulder the mechanism is unlocked by the recoil, the shell is out almost as soon as the gun cracks, and another shell can be thrown in while catching sight on the next bird. The action of a Winchester slide in the hands of an expert is almost automatic.

Quails often get up in a scattering manner and I have seen 5 and 6 birds killed by one man with a Winchester when they raised in this way.

Again Black Jack says: "Everyone knows that the original game hog was the old fellow with the double barrel muzzle loader who sneaked up and ground raked his birds with both barrels." This is no doubt true, but how about the modern game hog who takes one shot on the ground and 5 in the air, using a Winchester. Not every man can do this, but it does not take much practise to get 3 or 4 shots at a bunch of birds at one flushing, if they rise close to the hunter.

A man is not necessarily a game hog because he uses a Winchester; but a pump gun in the hands of a game hog is far more deadly than the double barrel and nine-tenths of the game hogs use them. Notice the picture on page 442 of JUNE RECREATION.

F. B. M., Waterloo, Ind.

#### PRAISES THE COLT.

E. J. Pratt asks for information as to Colt Lightning rifle. I own one, a 38-40, and have used it some years. It is the most accurate rifle I ever used, up to limit of the cartridge. With smokeless powder and soft mushroom point metal patched bullet it is a good deer gun for moderate ranges, say 150 yards. It is handy and light, and can be fired faster than any lever action gun. Still it has some defects. Cartridges must chamber loosely, as it lacks the power to push a tight shell into the chamber. Have had it jam when working it quickly, as the short cartridge throws up a little too high and the bullet strikes above the chamber. That happens only when the fore end is pulled back with a strong jerk;

at times a fellow does such things when in a hurry.

If some of the owners of 30-30s, 30-40s, etc., would try the following light loads perhaps they would be as well pleased as I have been: Five or 6 grains, weight, of Laflin & Rand Infallible shot gun powder with 100 grain hard lead bullet, lubricated, seated in short range shell, no crimp; or 10 or 12 grains, weight, same powder, with Savage full jacket miniature bullet, 100 grains loaded as above for a longer range. These loads are clean, quick, cheap and accurate, and the last is really powerful. The gun is not hard to clean if ammonia is used to cut the waxy residue. With my 30-40, sights must be raised for these loads as they shoot low, but group the shots nicely. Have tried low pressure smokeless for small loads and can not get as good results as with Infallible.

F. U. R., Appleton, Wis.

#### A LATE INVENTION.

724,327.—Attachment for Firearms. Ross M. G. Phillips, Los Angeles, Cal., assignor to Ideal Holster Company, Los Angeles, Cal., a corporation of California. Filed Oct. 16, 1901. Serial No. 78, 881. (No model.)

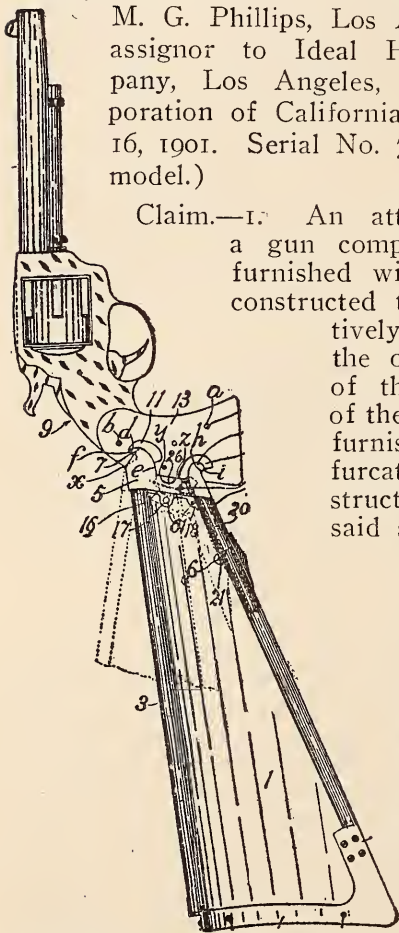

Claim.—1. An attachment for a gun comprising scales furnished with seats and constructed to be respectively mounted on the opposite sides of the back-strap of the gun; a stock furnished with bifurcated jaws constructed to engage said seats; one of said jaws being fixed on, and the other pivotally connected with, the stock; means for actuating the movable jaw to move the same to and from its seats; and a device constructed to lock and unlock said actuating means.

#### FLINCHING OR BULLET DRIFT?

In May RECREATION Dr. Douglas Brown attempts to criticise the 30-40 rifle. It is

not a reliable gun, he says; the barrel is too light, and, owing to the tremendous initial velocity, the bullet has a lateral swerve. Will the Doctor kindly explain how he ascertained that startling fact?

The 30-40 cartridge was tested with various others of both American and foreign manufacture, for accuracy, range, trajectory and penetration, by the U. S. Ordnance Bureau before being adopted by the U. S. Army, and was pronounced the peer of them all. Had the Doctor been present to advise the Ordnance Bureau of the lateral bullet swerve no doubt the Army would to-day be using the 40-82 or the 45-90, which the Doctor claims are superior guns.

The 30-40 is not only an accurate gun at extreme ranges, but ranks first among the most powerful game cartridges manufactured. From experience and observation of its effect on large game, with which this country abounds, I am sure the soft nose 30-40 cartridge is strong enough for any game on this continent. I am likewise positive that the 30-40 Winchester rifle barrel is sufficiently strong and accurate for any sportsman not prejudiced by the bullet swerve discovered by Dr. Brown.

I have noticed that those who find fault with the accuracy of guns usually flinch when firing, and thus impart a lateral swerve to the barrel and it is my opinion that the Doctor is in this gun shy class.

P. A. Melick, M. D., Williams, Ariz.

#### TO REMOVE LEAD.

How should buck shot be loaded so as to give the best possible pattern in a modified choke gun at 75 to 100 yards?

Where can I obtain the old fashioned wire cartridges or shot concentrators, such as were used in muzzle loaders?

What is the best way to remove lead from rifle barrels?

J. W. Dunbar, Mammoth Springs, Ark.

#### ANSWER.

Buck shot should be loaded in layers, one deep, between thin wads, putting a sufficient number, depending on the size, in each layer to chamber; that is, so as not to more than fill the bore at the smallest diameter.

Write to Hartley & Graham, 317 Broadway, New York city, for information as to the wire cartridges.

To remove lead from rifle barrels, if this can not be done with a brass wire brush, close up one end of the barrel with a cork and fill it with mercury, allowing the latter to remain in the barrel over night or until the lead is removed.

A metal patched bullet will, of course, wear the inside surface of a rifle barrel more than a softer bullet will. Just how much more has not been definitely determined. A great many thousand rounds have been fired

from the Krag regulation U. S. Army rifle without causing deterioration in the shooting qualities.—EDITOR.

#### WHO CAN TELL HIM?

Like many of your readers I have been looking for an all around rifle, one suitable for either man or woman to use at targets and on game, and taking various loads adapted for anything from ruffed grouse to moose. Have thought that, since the production of a high pressure smokeless cartridge for this caliber, the 32-40 would most nearly fill the bill.

What is the twist of rifling in Savage 32-40?

What is the velocity, trajectory, accuracy and recoil of the black, the smokeless and the high pressure smokeless loads, respectively?

How does the 32-40 high pressure smokeless load compare with such loads as 30-30, 30-40 and .303 Savage as regards power and accuracy?

In black powder loads the U. M. C. Company list 4 cartridges: 32-40-150 Remington, 32-40-165 Winchester, 32-40-165 Marlin, and 32-40-185 Bullard. Which of these does the Savage take? What is the difference between the Marlin and Winchester cartridges?

What are comparative merits of rifle and gun shot butts?

S. B., St. John, N. B.

Will some of my readers please answer.—EDITOR.

#### 13-INCH STOCK THE BEST.

Why do not the Savage people make standard stocks on their guns? I have heard many complaints on account of their making 13 inches the standard length while nearly every shooter uses a 14 inch stock. With a stock of that length the Savage would be perfection. Two or 3 riflemen around here have bought other guns in place of the Savage, on account of its short stock, at the same time declaring that the Savage in other ways was the best gun they had ever owned. Maybe the Savage company will enlighten a number of users of their guns on this point.

J. B. Burnley, Mexico City, Mex.

#### ANSWER.

We have found a 13 inch stock most satisfactory and suitable to the average shooter. In fact in this respect, the length of the Savage stock, from the trigger to center of butt plate, is somewhat longer than that furnished on other American repeating rifles. Of course, we can supply stocks of any drop or length desired, but for any special dimensions we are obliged to make an additional charge of \$10 list over the

regular price of the butt stock. This may seem excessive to the purchaser, but it is necessary to cut the stock out of solid block by hand. That, of course, is slow and expensive work.

Savage Arms Company.

#### SINGLE TRIGGER.

722,706.—Single Trigger Mechanism. James J. Hewson, Macleod, Canada, assignor of one-half to William Francis Cochrane, Macleod, Canada. Filed October 9, 1901. Serial No. 78,080. (No model.)

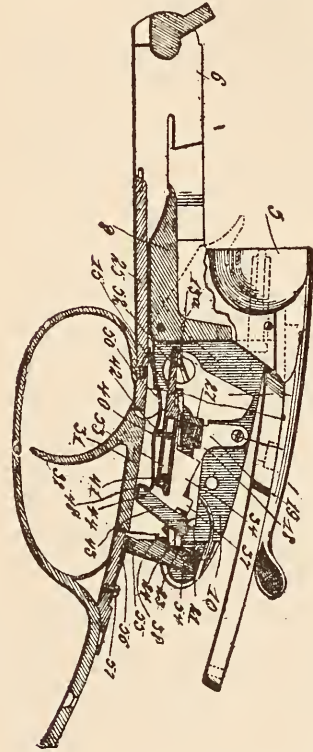

Claim.—1. In a firearm, the combination with gunlocks, of a trigger provided with means for successively actuating the gun locks and having a locking shoulder, a detent moulded in operative relation to the trigger and arranged to have interlocking engagement with said locking shoulder and having a squared lower end,

and a detent spring pressing upwardly against said squared lower end to normally hold said detent free from the trigger.

#### NOT FOR GAME.

I intend going to Southeast Alaska in August. I am not going on a hunting expedition, but should like to be prepared for any game, big or little, that comes within range. I object to the weight of a Savage or Winchester, and am informed by experts that a Luger pistol will answer all purposes and protect me from any attack providing I can see the animals, stand my ground, and shoot.

Mc., Detroit, Mich.

#### ANSWER.

The Luger pistol is a powerful small arm and has approximately the killing power of a 32-20 black powder cartridge shot from the ordinary hunting rifle. It is not, however, well adapted for game shooting, inasmuch as it requires much greater skill to shoot it accurately than a shoulder weapon. A skeleton stock attachment can be bought for the Luger and Mauser pistols, but even with that it is difficult to obtain quick, accurate shooting. As a weapon of defense

at close range, either of the arms named would be effective. When, however, a hunter is charged by large and dangerous game, a much heavier load is desirable.

If you want an automatic pistol, buy a Colt. It is an American product, and if parts are needed at any time they can be had by sending to the Colt factory at Hartford, Conn.—EDITOR.

#### LITTLE DIFFERENCE.

Please tell me which is the larger caliber, a 30-30 or a .303? Which has the greater range and penetration?

Will a 30-30 carbine with a 20 inch barrel have less range and penetration than a 30-30 rifle with a 26 inch barrel?

H. R. Cole, Kingman, Ariz.

#### ANSWER.

	Diam. of bullet	Bul-let	M. vel.	Penetration metal patched bullet
30-30 Winchester	.305	160	1885	35 $\frac{7}{8}$ in. boards
.303 Savage	.311	180	1840	37 $\frac{7}{8}$ in. boards

From the above table you will note that in the standard length of barrel there is little difference between the 2 cartridges. The .303 Savage would probably be the most effective charge of the 2, but would not have so flat a trajectory as the 30-30 Winchester. The difference between the 20 inch barrel and the 26 inch barrel, so far as range and penetration is concerned, would amount to little. It would, however, be more difficult to do as good shooting with the short barrel as with the longer barrel, on account of the shorter distance between the sights.—EDITOR.

#### SMALL SHOT.

Under separate cover I have mailed you 2 empty Peters shells, also the jackets of same, which stuck in the breech of my rifle when fired, allowing the lead filling to blow out and lead the barrel. I am not in the habit of using the Peters brand, but on leaving Washington, D. C., I was in a hurry to catch my train and as the dealer I called on had nothing else, I was foolish enough to buy a box of Peters.

I have a 30-30 Savage and have never had any trouble with Savage ammunition or the U. M. C. I do not know if anyone else has had this trouble or not; I trust they have not, as my rifle is badly leaded. When I use any more Peters shells I want someone to kick me.

Z. F. Bowman, Magnolia, Ind.

#### ANSWER.

The shells referred to in the above were duly received. They appear to be of the standard pattern and bear the Peters imprint on the butt. The bullets were of the soft point style. The metal jackets are intact, but have no lead in them.—EDITOR.

I will answer Mr. Savage's question in April RECREATION by saying that the Ideal No. 3 tool is the best instrument to reload .303 shells. I use a Savage rifle and reload all my short range ammunition. I use Ideal No. 3 tool with muzzle resizing die, and it is absolutely essential to use the Ideal dipper. It insures a full sized, smooth bullet. I cast my bullets 1 to 10. In reloading I use 8 or 10 grains of DuPont No. 2 smokeless, a low pressure powder, and I measure it with an Ideal universal measure. The powder should be measured accurately to insure uniform results. I have used several kinds of powder but DuPont's No. 2 seemed most satisfactory. The best bullet I have found so far is Kephart's. The Ideal people make a mold for this bullet. I like the Savage rifle. It is a nicely balanced gun and at the same time neat looking and accurate. If properly loaded the short range ammunition is all right. An excellent group can be made with it at 100 yards.

Charles Opp, Beaver, O.

719,019.—Trigger Mechanism for Firearms. Edwin M. Liebert, Dusseldorf, Germany. Filed June 28, 1900. Serial No. 21,876. (No model.)



Claim.—A gun provided with a slide movable on the grip of the stock parallel to the longitudinal axis of the gun, a rod connected to the slide, a roller carried by the rod, and a trigger lever having a sear nose, a notch and a curved arm, said notch and arm being adapted to be engaged by the roller.

When Sam Stevens, of Cripple Creek, Col., criticized, in May RECREATION, the 25-35 Winchester, he was condemning the best gun ever made. I have worn out a number of rifles of different makes: the poorest was a 38-55 Marlin; the best, a 25-35 Winchester. The latter caliber is largely used by the Seminole Indians hereabouts and what they don't know about game getting is not worth knowing. I have killed 10 deer with my 25-35. In every case the bullet went clean through the animal and no second shot was needed.

Chas. E. Tartar, Estero, Fla.

I am, like Mr. Morris, interested in long barreled guns and can go him one or 2 feet better on length, though I can give no date, as the maker neglected to stamp it. I bought an old duck-gun from an Englishman who brought it from London, England, in 1848. It is a flint lock 11-24 inch bore,

3 inches in diameter at breech and 8 feet long. It weighs 80 pounds and is in good condition. I also have 50 or 60 other relics in the gun line. If anybody can beat the above let us hear from him through RECREATION.  
C. W. Hard, Medina, O.

I saw an article in a cheap magazine by a person whom you undoubtedly branded as a hog. It said the reason Marlin did not advertise in your magazine was because he would not pay the double price for his ad which you asked of him. Marlin probably has no idea of the cost of advertising in a first class magazine and being a cheap concern advertises in magazines of a like class.

All departments of your magazine appeal to me; the hog department being exceptionally good.

James Wilson, Lyman, Ia.

It will be noticed that the patch on Peters bullets extends to the end of the lead, the bullet being flat on the end, while on Winchester bullets the lead extends nearly 3-16 inch beyond the patch.

My experience leads me to think the Peters bullets do not mushroom so much as the Winchester's, thus not having so deadly an effect.

I should be pleased to hear, through RECREATION, from any one who has noticed this.

Walter K. Atchison, Grayrocks, Wyo.

What are the comparative values of the following cartridges in regard to their accuracy, trajectory, and killing power? 22 long rifle, rim fire; 22 Winchester, rim fire; 25 Stevens, rim fire; 22 Winchester single shot, center fire; 22-15-60 Stevens, center fire, 25-20 center fire, and 25-21 Stevens, rim fire? I should like to hear from readers who have used the Stevens Ideal, No. 55, ladies' model.

Charles Burns, Beverly, Mass.

What is the largest number of No. 6 shot a 16 gauge gun will put in a 40 inch circle at 40 yards?

H. E. Campbell, West Windham, N. H.

ANSWER.

Depending on the amount of choke, a 16 gauge gun will put 60 to 70 per cent. of the charge into a 30 inch circle at 40 yards. Exceptionally good guns will do even better. I have no records of shooting at a 40 inch circle.—EDITOR.

I agree with J. B. Knapp in regard to the killing power of black powder. I find I can kill at greater range with black than with smokeless powders.

Will some one who has used high power loads in a 32-20 rifle, tell me if the metal

jackets injured the rifling? Are the hollow point bullets effective on small game?

W. B. Sweet, Ithaca, N. Y.

Can you tell me the difference as regards pattern, penetration and carrying power, of the following shot gun bores: full cylinder, modified cylinder, full choke, modified choke and any other forms or varieties of bore there may be?

Forrester H. Scott, Philadelphia, Pa.

Will the readers of RECREATION please answer.—EDITOR.

We have reached an age of great variety in arms and calibers, enough, it may seem, to satisfy the most exacting, but let me put in a plea for just 2 more. First, Harrington & Richardson or a Forehand revolver to use the 32 rim fire cartridge, both short and long. Second, a model 1903 Savage to use the 25 rim fire.

G. W. McKay, Kelsey, Minn.

In December RECREATION H. R. von Sommel, of Pleasantville, N. Y., says a bullet from a small caliber can be driven through a 6 foot oak tree. I am somewhat of a small bore rifle crank myself, but I think Mr. von Sommel lacks experience, or the oak up there is different wood from what it is here.

E. G. Pettel, Marietta, Ohio.

I notice Mr. Peregrine condemns the Savage, while admitting he never owned one. I have used a Savage 3 years, and consider it superior to the Winchester 30-30 and 30-40. Have killed a number of deer with my gun, some at 600 yards, and never had to fire a second shot.

E. H. Ream, Vacaville, Cal.

Which will give the greater penetration at a given distance, a full choke or a cylinder bore?

G. W. Nolan, Middletown, N. Y.

ANSWER.

Other things being equal, the full choke has the advantage in penetration.—EDITOR.

I should like to hear through RECREATION from someone who has used the Elterick patent rifle bullet shell. Can they be used in repeating shot guns? Will a repeating shot gun last as long as a double barreled?

G. D. Earll, Great Barrington, Mass.

All game is scarce here except ducks and geese. These can not be reached on the lakes by a shot gun. I should like to hear the experience of brother hunters with rifles for such game; especially the 25-20.

Lew A. Rippey, Sturgis, Mich.

## NATURAL HISTORY.

When a bird or a wild animal is killed, that is the end of it. If photographed, it may still live and its educational and scientific value is multiplied indefinitely.

### OSTRICH EGGS.

E. H. RYDALL.

In California and Arizona ostrich eggs are being laid by descendents of African ostriches. These eggs weigh about  $3\frac{1}{2}$  pounds each and contain 30 ounces of albumen; they taste the same as eggs of the familiar hen, and are sometimes served at the tables of the palatial hotels of Southern California. Few ostrich eggs are consumed, however, for they are worth at the present market price \$70 a dozen; they appear on the bill of fare chiefly as an advertisement of the local ostrich farm. Other eggs are frequently placed on the office counters of California hotels for the same purpose.

Ostriches lay eggs every February and August. They first dig a hole in the ground some 12 inches deep and four in diameter. Every other day during the months named the hen deposits an egg in this hole; when some 15 have been deposited she will lay a few more around her pen and then sit down to hatch the group. After she has been engaged 2 weeks in this occupation, the ostrich farmer removes the eggs one by one until nothing remains in the nest except the dummy. Sometimes a hen will lay a second clutch, but in many cases she will not. The farmer hatches these eggs in an incubator; not because the hen would not hatch them, but because the farms have many visitors and a nesting hen startled by the sudden appearance of a stranger is liable to break an egg in her excitement, which means an ultimate loss to the institution of \$150, the value of a full grown ostrich.

The ostrich is a faithful domestic creature. The hen will attend to her duties carefully if not disturbed, while the male guards the nest at night by sitting on the eggs, leaving the wearied hen, who has been doing duty all day, to rest from her labors. The male ostrich is black, his body thus protects the eggs at night and makes them invisible to marauders; the female is grey, the color of the desert, so that she also is invisible from a distance; thus, between the black and grey covering, the white eggs are continually hidden from the observation of the passing hunter. The male ostrich becomes fierce at breeding times and will attack anyone found in the vicinity of its nest; at other times it will join the hen in flight on the approach of danger. The male emits a roar during the night that resembles the roar of the African lion and is often mistaken for it, even by

the experienced lion hunter. The hen is voiceless and timid. Of the 2 the hen is the more affectionate.

The ostrich industry of the United States is controlled by the Hebrews. It is yet in its infancy, and to obtain some idea of its probable future one has to glance at the history of the South African ostrich industry. There some 400,000 domestic ostriches are now supplying the world with ostrich feather finery and yielding to the British and Boer farmers an annual income of \$8,000,000. Fortunes have been made and lost in this industry since its inception in 1865. At present the ostrich farmers of America have 3 avenues of income, the exhibition of the birds to tourists, who pay to see this strange African biped in all its various ages; the sale of ostrich young to the American ostrich trust, whose headquarters are at Phoenix, Ariz.; and the sale of ostrich feathers to the feminine contingent of the American public. Each ostrich will yield about \$40 worth of ostrich finery every year. As an ostrich is believed to reach the age of 60 years, there is a profitable and steady income in view for the ostrich farmer. The expense of keeping ostriches is small, not greater than that of keeping sheep. The cost of preparing ostrich feathers for the use of the millinery world is almost equal to the cost of the crude material. Skilled artisans in the various lines of manufacture have to be employed; in this the French excel, and the finest ostrich feather dressers in the world are found in Paris.

### AN EXPERIENCE WITH A MOUNTAIN RAT.

Gunnison, Colorado, 200 miles West of Denver, is a picturesque town. It was once considered a rival of Denver, being surrounded by rich, ore-bearing mountains. Its location on the Western slope of the great Rockies was, however, a commercial disadvantage and it soon fell behind in the race. While the beautiful region suffered consequently from a financial point of view, it still retains its charm as a resort for pleasure seekers. Its hunting and fishing are not surpassed in all the country. Deer abound in droves, and its beautiful mountain streams swarm with rainbow trout and other game fishes.

Roger Freeman and I, with a deaf old shepherd dog and a dangerous looking muzzle loading shot gun, once went into the hills near Gunnison for a day's hunt. There were many coyotes and an occasion-

al bobcat or skunk. There were plenty of deer farther up in the hills, but they were out of season.

After hunting all morning and getting but two rabbits, we were tired and discouraged. We stopped at the head of a gulch, on a large rock, and ate our lunch, after which we felt better. After resting awhile we started down the gulch, which was a homeward direction. We had heard of an old mine in the gulch, but not knowing exactly where it was, we reached it before we expected to. Probably we should have passed it had not Shep made a tremendous uproar at the entrance. We ran to him, supposing game was in sight, but to our disgust we found nothing but the dreary black hole. We tried in vain to stop the barking of the excited dog, so we decided to make an investigation of the old mine. With a piece of old pine board we made a torch. We took one gun with us in case of an encounter with some terrific beast, which would not have been much of a surprise in a place of that kind.

I took the lead with the torch and Roger followed with the old muzzle loader, full cocked. As we crept into that damp, dark hole, our teeth were chattering *presissimo*. We had gone about 50 feet, when Shep sprang past us with a savage growl and rushed at something. I could not see what it was, for they were in a fierce struggle, and we dared not shoot lest we hit Shep. In my excitement I held the torch too near the roof, and the dampness instantly put out our light. I hunted in my pockets for a match, but before I could light my torch again something hit me on the head, and out of the mine we both went as fast as our legs could carry us, never stopping until we were a mile from the mine and on the main road home.

We had quite a vigorous dispute as to what that old mine was inhabited with. I said wildcats, but Roger was convinced it was spirits. To our relief and astonishment the question was settled when Shep came up with a large mountain rat in his mouth, scratched a little, but none the worse for his encounter.

M. L. Goff, Gunnison, Colo.

#### A TORMENTED OWL.

February 2 I was attracted by the chirping of about 100 sparrows. The chirping grew angrier and angrier until it became a yelling and screaming din. On investigating I found that a poor saw-whet owl was the cause of the rumpus. It was snugly hid in a fir tree and looked as if it would enjoy a good long sleep, but the sparrows' scolding forbade it.

I have often read that the owl has suffered endless persecution by other birds

when found asleep in the day time, and I was glad to have the opportunity which verified this statement.

"As saucy as an English sparrow," is a common expression. These sparrows were uncommonly saucy. The owl seemed trying its best to ignore the scoldings of the little shrews, and this fact seemed to anger the sparrows still more. About a dozen flew to the branch on which the owl was perched and jostled her. If the owl had not made a few sleepy pecks at them they would have crowded her from the branch.

Desiring to obtain a better view of her, I shook the branch. She flew away out of sight, but still followed by her tormentors. I again heard the sparrows a few rods away, and with small difficulty found the owl seated on a branch of a cedar and again having a court of screaming sparrows about her. On my nearer approach she focused her large yellow eyes on me and again took flight, entering a barn through a hole which was barely large enough to admit her.

This little incident showed me that owls are not entirely blind in the daytime, and that sparrows are more saucy and persistent than I ever imagined them to be.

Litta Voelchert, Manitowoc, Wis.

#### TO PRESERVE BIRDS' NESTS.

In making a collection of bird's nests, how much of the branch on which a nest hangs should be preserved? How can mud plastered nests be kept from crumbling and falling apart?

I hope RECREATION will publish more articles like the one by J. A. Loring in the May number. The drawings by L. Grey are of great value to a student of birds.

O. M. Gates, Mansfield, O.

#### ANSWER.

In collecting nests, it is not advisable to save more than 6 inches of the branch on which a nest is situated. To do otherwise makes a collection so large that it is difficult to provide cases to properly protect it from dust and destruction. When collecting nests each should be carefully wrapped in every direction with thread to preserve its shape until it is finally placed in its case in the collection. The nests are mounted by placing them on wire standards, which are fastened to small wooden pedestals, which carry the label. It is a difficult matter to handle nests made of mud, and keep them from falling apart; but, by treating them as carefully as eggs are treated, it can be accomplished. The best course to pursue is to take nests after the young have been reared and the birds have flown, place them in a bed of tow, or cotton, in a box of the right size, and carry by hand to the collection. To prepare such nests for exhibi-

tion they can be glued to a rough board, with ordinary liquid glue, in which a little plaster of paris has been mixed, to make it of the consistency of paste.—W. T. H.

#### SNAKE MYTHS.

A European by birth and a recent comer to this country, I am naturally unfamiliar with the snakes of South Carolina, where I now live. My good neighbors tell me, and apparently believe, most marvelous stories about them. The black snake is said to chase anyone who disturbs it, and, as it can outrun a man, is thus highly dangerous. It is true that all I have found could outrun me, but I have so far been the chaser. The coachwhip snake, it is asserted, will wrap its body around a man's leg and inflict severe punishment with its tail. Everything considered, the coachwhip is more dread than any other snake here. I have encountered a few and stirred them up. All the fight I could get out of them was apparently to come off at some distant point, to which they would invariably head. Then there is the horn snake, which can thrust its horny tail through a tree and kill a man on the other side. The hoop snake, I am told, takes its tail in its mouth when in a hurry, and rolls swiftly on its way.

All this information has been imparted to me by honest and upright people, whose veracity I am loath to question. Is there any foundation for these stories?

I know the black snake and coachwhip kill and devour mice, snails, bugs and the like. I must also admit that they eat birds when they can get them, especially fledglings; but is there any valid reason for the almost universal practice of killing all snakes wherever found?

F. J. G., New Brookland, S. C.

#### NATURAL HISTORY NOTES.

One rainy afternoon my attention was attracted by the strange actions of a pet canary whose cage hung inside an open window. On investigation I found, clinging to the window screen a small mouse colored bird, about the size of an English sparrow. It had a small curled beak and its wings lapped across its tail. Please tell me the name and habits of this bird.

M. H. E., New Cumberland, Pa.

#### ANSWER.

The bird referred to was, in all probability, a house wren, one of the most sociable and interesting birds that frequent the dwellings of men. They are exceedingly pert and lively, and if they can be induced to nest about a house, their cheerful twitter is a most pleasing sound.—W. T. H.

In a small swamp near here I have noticed a jet black bird with crimson at the butt of each wing. It is as large as a robin, but its beak is short, like a sparrow's. It seems to feed among the cattails. Later I saw its mate, which has no red, and is brown in color. What is the name of this bird and what are its habits?

A. Johnson, Gloversville, N. Y.

#### ANSWER.

This bird is the redwinged blackbird, *Agelaius phoeniceus*. It inhabits marsh and cattail swamps and nests over water in reeds or cattails. It ranges Westward and Northward to Great Slave lake and winters in the South.—EDITOR.

I have the head of a hermaphrodite mule deer, killed February 22, last, which has what I think are permanent horns, as other deer shed in January. The horns are much more slender than those of the regular mule deer. Can you inform me if those horns are permanent and if such heads are common?

W. A. Meachen, Marysville, B. C.

#### ANSWER.

No deer retains its horns permanently, but they sometimes vary as much as 3 months in the time of shedding them. Such freaks of nature as that described are not common.—EDITOR.

Recently I found an orchard oriole drowned in a basin of water which was sitting on the ground. There had been a heavy wind and rain storm the night previous, and the bird had evidently been blown from the perch into the basin.

H. H. Birkeland, Roland, Ia.

Have you any friends who are interested in hunting, fishing, natural history, game protection or amateur photography? If so why not send each of them a year's subscription to RECREATION for a Christmas present. The stories in RECREATION are the actual experiences and observations of men who live out of doors, who shoot, fish, photograph and study nature; and they depict outdoor life as it is.

In no other way could you give a friend so much value for the money as by making him a present of RECREATION.

Landlady—"Mr. Slopay, have you any idea of the size of your bill?"

Mr. Slopay (despairingly)—"Have I? Why, I've dreamed 3 nights in succession that I was a pelican."—Judge.

Conductor: I want to punch your ticket.  
Farmer Ragweed: Punch the boy; he's swallowed the ticket.—Boston Post.



# THE LEAGUE OF AMERICAN SPORTSMEN.

## GENERAL OFFICERS

*President*, G. O. Shields, 23 W. 24th St., New York.

*1st Vice-President*, E. T. Seton, 80 West 40th St., New York.

*2d Vice-President*, W. T. Hornaday, 2969 Decatur Ave., Bedford Park, N. Y.

*3d Vice-President*, Dr. T. S. Palmer, Dept. of Agriculture, Washington, D. C.

*4th Vice-President*, A. A. Anderson, 80 West 40th St., New York.

*5th Vice-President*, Hon. W. A. Richards, General Land Office, Washington, D. C.

*Secretary*, A. F. Rice, 155 Pennington Ave., Passaic, N. J.

*Treasurer*, Austin Corbin, of the Corbin Banking Co., 192 Broadway, New York.

## ALASKA DIVISION.

Dr. E. M. Rininger, Chief Warden, Nome.

## ARIZONA DIVISION.

M. J. Foley, Chief Warden, Jerome.

## ARKANSAS DIVISION

W. R. Blockson, Chief Warden Eureka Springs.

## CALIFORNIA DIVISION.

Dr. David Starr Jordan, Chief Warden, Leland Stanford University.

## COLORADO DIVISION.

A. Whitehead, Chief Warden, 303 Tabor Building, Denver.

## CONNECTICUT DIVISION.

Hon. F. P. Sherwood, Chief Warden, Southport; Dr. H. L. Ross, Vice-Warden, Canaan; H. C. Went, Sec.-Treas., Bridgeport.

## DISTRICT OF COLUMBIA DIVISION.

C. H. Townsend, Chief Warden, U. S. Fish Commission.

## FLORIDA DIVISION.

W. W. K. Decker, Chief Warden, Tarpon Springs

## GEORGIA DIVISION.

J. J. Doughty, Chief Warden, Augusta.

## IDAHO DIVISION.

L. A. Kerr, Chief Warden, Kendrick

## ILLINOIS DIVISION.

M. D. Ewell, M.D., Chief Warden, 59 Clark St., Chicago; F. M. Taber, Vice Warden, 144 Kinzie St., Chicago; G. C. Davis, Sec.-Treas., 123 S. Central Ave., Austin.

## INDIANA DIVISION.

Frank L. Littleton, Chief Warden, 30½ East Washington St., Indianapolis; J. J. Hildebrandt, Vice Warden, Logansport; T. J. Carter, Sec.-Treas., State House, Indianapolis.

## IOWA DIVISION.

Carl Quimby, Chief Warden, Des Moines; C. C. Proper, Sec.-Treas., Des Moines.

## KANSAS DIVISION.

O. B. Stocker, Chief Warden, Wichita; A. J. Applegate, Sec.-Treas., 113 E. 1st St., Wichita

## KENTUCKY DIVISION.

Geo. C. Long, Chief Warden, Hopkinsville.

R. L. Brashear, Sec.-Treas., Bowling Green.

## MAINE DIVISION.

Col. E. C. Farrington, Chief Warden, Augusta.

## MARYLAND DIVISION

J. E. Tylor, Chief Warden, Baltimore.

## MASSACHUSETTS DIVISION.

Heman S. Fay, Chief Warden, Hazleton Block, Marlboro; J. E. Tweedy, Vice-Warden, North Attleboro; A. C. Lamson, Sec.-Treas., 194 Main St., Marlboro.

## MICHIGAN DIVISION.

J. Elmer Pratt, Chief Warden, Grand Rapids; R. S.

Woodliffe, Vice-Warden, Jackson; A. B. Richmond, Sec.-Treas., Grand Rapids.

## MINNESOTA DIVISION.

Dietrich Lange, Chief Warden, 2294 Commonwealth Ave., St. Paul.

H. A. Morgan, Vice-Warden, Albert Lea; Prof. O. T. Denny, Sec.-Treas., St. Paul.

## MISSOURI DIVISION.

Bryan Snyder, Chief Warden, 726 Central Bldg., St. Louis.

## MONTANA DIVISION.

Professor M. J. Elrod, Chief Warden, Missoula; Sidney M. Logan, Vice-Warden, Kalispell; R. A. Waagner, Sec.-Treas., Bozeman.

## NEBRASKA DIVISION.

Fred. E. Mockett, Chief Warden, Lincoln; P. O'Mahony, Sec.-Treas., Lincoln.

## NEVADA DIVISION.

Dr. W. H. Cavell, Chief Warden, Carson.

Geo. W. Cowing, Sec.-Treas., Carson.

## NEW HAMPSHIRE DIVISION.

Dr. A. F. Barrett, Sentinel Bldg., Keene, Sidney Conant, Sec.-Treas., Keene.

## NEW JERSEY DIVISION.

Percy Johnson, Chief Warden, Bloomfield; Dr. W. S. Colfax, Vice-Warden, Pompton Lakes; I. V. Dorland, Sec.-Treas., Arlington.

## NEW MEXICO DIVISION.

P. B. Otero, Chief Warden, Santa Fe.

## NEW YORK DIVISION.

John R. Fanning, Chief Warden, Powers' Bldg., Rochester; Col. R. E. Moss, Vice-Warden, Wallack's Theatre, New York City; Dr. C. C. Curtis, Sec.-Treas., Columbia College, New York City.

## NORTH DAKOTA DIVISION.

Dr. W. D. Jones, Chief Warden, Devil's Lake.

## OHIO DIVISION.

W. E. Gleason, Chief Warden, Mitchell Bldg., Cincinnati; A. C. Thatcher, Vice-Warden, Urbana.

## OKLAHOMA DIVISION.

W. M. Grant, Chief Warden, Oklahoma City.

## ONTARIO DIVISION.

C. A. Hammond, Chief Warden, Box 701, St. Thomas; D. L. Mells, Sec. Treas., St. Thomas.

## OREGON DIVISION.

Robert F. Kelly, Chief Warden, Box 188, The Dalles; C. B. Cushing, Sec.-Treas., The Dalles.

## PENNSYLVANIA DIVISION.

C. F. Emerson, Chief Warden, 189 N. Perry St., Titusville; Hon. C. B. Penrose, Vice-Warden, 172 Spruce St., Philadelphia; E. Wager-Smith, Sec.-Treas., 1026 Ridge Ave., Philadelphia.

## RHODE ISLAND DIVISION.

Zenas W. Bliss, Chief Warden, 49 Westminster St., Providence.

## SOUTH CAROLINA DIVISION.

C. F. Dill, Chief Warden, Greenville.

## SOUTH DAKOTA DIVISION.

D. C. Booth, Chief Warden, Spearfish; John C. Barber, Sec.-Treas., Lead.

## TENNESSEE DIVISION.

Hon. G. C. Martin, Chief Warden, Clarksville; Hon. Austin Peay, Jr., Sec.-Treas., Clarksville.

## TEXAS DIVISION.

Prof. S. W. Stanfield, Chief Warden, San Marcos; W. E. Heald, Sec.-Treas., San Angelo.

## UTAH DIVISION.

Hon. John Sharp, Chief Warden, Salt Lake City.

## VERMONT DIVISION.

W. E. Mack, Chief Warden, Woodstock; S. C. White, Sec.-Treas., Woodstock.

## VIRGINIA DIVISION.

R. G. Bickford, Chief Warden, Newport News. C. O. Saville, Vice Warden, Richmond; M. D. Hart, Sec.-Treas., 1217 East Main St., Richmond.

## WASHINGTON DIVISION.

F. S. Merrill, Chief Warden, Spokane; F. A. Pontius, Sec.-Treas., Seattle; Munro Wyckoff, Vice-Warden, Pt Townsend.

WEST VIRGINIA DIVISION.

E. F. Smith, Chief Warden, Hinton,  
WISCONSIN DIVISION.

Frank Kaufman, Chief Warden, Two Rivers; Dr.  
A. Gropper, Sec.-Treas., Milwaukee.

WYOMING DIVISION.

H. E. Wadsworth, Chief Warden, Lander; Frank  
Bond, Sec.-Treas., Cheyenne.

*Applications for membership and orders for badges  
should be addressed to Arthur F. Rice, Secretary, 23 W.  
St., New York.*

LOCAL WARDENS IN NEW YORK.

County.	Name of Warden.	Address.
New York	Conrad L. Meyer,	46 W. Broadway.
Livingston	M. De La Vergne,	Lakeville.
"	K. S. Chamberlain,	Mt. Morris.
"	Henry Skinner,	Springwater.
"	Dr. J. W. Cowan,	Geneseo.
Albany,	C. D. Johnson,	Newtonville.
"	Kenneth E. Bender,	Albany.
Broome,	John Sullivan,	Sanitaria Springs
"	R. R. Mathewson,	Binghamton.
Cayuga,	H. M. Haskell,	Weedsport.
Chemung,	Fred Uhle,	Hendy Creek,
"	M. A. Baker,	Elmira.
Cortland,	James Edwards,	Cortland,
Erie,	E. P. Dorr,	103 D. S. Morgan Building, Buffalo.
"	Marvin H. Butler,	Morilla.
Essex,	W. H. Broughton,	Moriah.
Franklin,	Jas. Eccles,	St. Regis Falls.
Montgomery,	Charles W. Scharf,	Canajoharie.
Oneida,	J. M. Scoville,	Clinton.
Orange,	Wilso' Crans,	Middletown.
"	J. Hampton Kidd,	Newburgh.
"	Thomas Harris,	Port Jervis.
Richmond,	Lewis Morris,	Port Richmond.
St. Lawrence,	Dr. B. W. Severance,	Gouverneur.
"	A. N. Clark,	Sevey.
Schenectady,	J. W. Furnside,	Schenectady.
Suffolk,	F. J. Fellows,	Central Islip, L. I.
"	P. F. Tabor,	Orient, L. I.
Tioga,	Geo. Wood,	Owego.
Washington,	C. L. Allen,	Sandy Hill.
"	A. S. Temple,	Whitehall.
"	J. E. Barber,	Dresden.
Westchester,	George Poth,	Pleasantville.
"	Chas. Seacor,	57 Pelham Road, New Rochelle.
"	M. W. Smith,	Croton Falls.
"	Ralph Gorham,	Mt. Kisco.
Dutchess,	} A. B. Miller,	Jackson's Corners'
Columbia,		
Onondaga,	James Lush,	Memphis.
Yates,	B. L. Wren,	Penn Yan.
"	Symour Poineer,	Branch Port.
Dutchess,	Chas. H. DeLong,	Pawling.
"	Jacob Tompkins,	Billings.
Queens,	Gerard Van Nostrand,	Flushing, L. I.
"	W. S. Mygrant,	46 Elton Street, Brooklyn.
"	P. A. Geepel,	473 Grand Ave., Astoria, L. I.
"	L. B. Drowne,	119 Somers Street, Brooklyn.
"	Louis C. Att	Broad Channel Hotel, Rockaway, L. I.
Ulster,	M. A. DeVal,	The Corners.
"	Wm. S. Mead,	Woodstock.
Jefferson,	C. J. Smith,	Watertown.
"	A. C. Cornwall,	Alexandria Bay,
"	Jos. Northrup,	Old Forge.
Herkimer,	D. F. Sperry,	154 West Utica St.
Oswego,	J. E. Manning,	Mahopac Falls.
Putnam,	H. L. Brady,	Watkins.
Schuyler,	G. C. Fordham,	Belvidere.
Allegany,	G. A. Thomas,	Sharon Springs.
Schoharie,	O. E. Eigen,	Glen Falls.
Warren,	Geo. McEch'on,	E. Shelby.
Orleans,	J. H. Fearby,	Windham.
Green,	W. J. Soper,	Lake Pleasant.
Hamilton,	David Aird, Jr.,	

LOCAL WARDENS IN OHIO.

Stark,	A. Dangeleisen,	Massillon.
Franklin,	Brook L. Terry,	208 Woodward Av., Columbus.
Cuyahoga,	A. W. Hitch,	161 Osborn St., Cleveland.
Clark,	Fred C. Ross,	169 W. Main St., Springfield.
Erie,	David Sutton,	418 Jackson St., Sandusky.
Fulton,	L. C. Berry,	Swanton.

County.	Name of Warden.	Address.
Allen,	S. W. Knisely	Lima.
Hamilton,	W. C. Rippey,	4465 Eastern Ave. Cincinnati.
Knox,	Grant Phillips,	Mt. Vernon.
Lorain,	T. J. Bates,	Elyria.
Ottawa,	Frank B. Shirley,	Lakeside.
Muskingum,	Frank D. Abell,	Zanesville.
Scioto,	J. F. Kelley,	Portsmouth.

LOCAL WARDENS IN CONNECTICUT.

Fairfield,	George B. Bliss.	2 Park Row, Stam- ford, Ct.
"	Harvey C. Went,	11 Park St., Bridge- port, Ct.
Fairfield,	Samuel Waklee,	Box 373, Stratford.
Litchfield,	Dr. H. L. Ross,	P. O. Box 100, Can- naan, Ct.
Middlesex,	Sandford Brainerd,	Ivoryton.
New Haven,	Wilbur E. Beach,	318 Chapel Street, New Haven Ct.
"	D. J. Ryan,	188 Elizabeth St., Derby.

LOCAL WARDENS IN MASSACHUSETTS.

Norfolk,	Orlando McKenzie,	Norfolk.
"	J. J. Blick,	Wrentham.
"	S. W. Fuller,	East Milton.
Suffolk,	Capt. W. J. Stone,	4 Tremont Row, Boston.
Worcester,	B. H. Mosher,	Athol.

LOCAL WARDENS IN NEW JERSEY.

Mercer,	Edw. Vanderbilt,	Dentzville, Trenton
"	Roland Mitchell,	730 Centre St., Trenton
"	F. C. Wright,	Trenton.
Morris,	Joseph Pellet,	Pompton Plains.
"	Chas. W. Blake,	Dover.
"	Francis E. Cook,	Butler.
"	Calone Orr,	Hibernia.
Somerset,	G. E. Morris,	Somerville.
Sussex,	Isaac D. Williams,	Branchville.
Union,	A. H. Miller,	Cranford.
"	C. M. Hawkins,	Roselle.
Warren,	{ Jacob Young, Keuben Warner, }	Phillipsburg.
Monmouth,	Dory-Hunt,	Wanaque.
Hudson,	A. W. Letts,	51 Newark St., Hoboken

LOCAL WARDENS IN PENNSYLVANIA.

Jefferson,	John Noll,	Sykesville.
Perry,	Samuel Sundy,	Lebo.
Warren,	F. P. Sweet,	Goodwill Hill.
"	Nelson Holmes,	Cornplanter.
Juniata,	Clifford Singer,	Oakland Mills.
"	Ezra Phillips,	McAlesterville.
Venango,	G. D. Benedict,	Pleasantville.
Potter,	Ira Murphy,	Coudersport.
"	Wiley Barrows,	Austin.
"	Chas. Barrows,	Austin.
Crawford,	Jasper Tillotson,	Tillotson.
"	Geo. T. Meyers,	Titusville.
"	J. B. Lamb,	Buel.
Cambria,	W. H. Lambert,	720 Coleman Ave., Johnstown.
Butler,	F. J. Forquer,	Murrinsville.
Allegheny,	S. H. Allen,	Natrona.
Beaver,	N. H. Court,	Beaver Falls.
"	W. R. Keefer,	"
McKean,	C. A. Duke,	Duke Center.
"	L. P. Fessenden,	Granere.
"	Wm. Holsinger,	Stickney.
Lackawanna,	Wm. Weir,	Moosic.
"	Wm. Major,	"
Carbon,	Asa D. Hontz,	East Mauch Chunk.
Cumberland,	J. C. Gill,	Mechanicsburg.
Wyoming,	Cyrus Walter,	Tunkhannock.
Tioga,	E. B. Beaumont, Jr.,	Lawrenceville.
"	G. H. Simmons,	Westfield.
Lycoming,	Jas. J. Brennan,	Oval.
"	B. D. Kurtz,	Cammal.
Delaware,	Waterhusson,	Ardmore.
Montgomery,	L. C. Parsons,	Academy.
Bradford,	Geo. B. Loop,	Sayre.
Clarion,	Isaac Keener,	New Bethlehem.
Cameron,	Harry Hemphill,	Emporium.
Clinton,	M. C. Kepler,	Empov.
"	Geo. L. Kepler,	"
"	R. T. Antes,	Pine Station.
Northumber-land,	{ G. W. Roher, 505 Anthracite St., Shamokin	
Elk,	D. R. Lobough,	Ridgway.
Fayette,	Ely Cope,	Cadwallader.

LOCAL WARDENS IN MICHIGAN.

County.	Name of Warden.	Address.
Ottawa,	W. H. Dunham,	Spencer.
Kalamazoo,	C. E. Miller,	Augusta.
Berrien,	W. A. Palmer,	Buchanan.
Cass,	Thomas Dewey,	Dowagiac.
Hillsdale,	C. A. Stone,	Hillsdale.
Lake,	John Trieber,	Peacock.

LOCAL WARDENS IN VIRGINIA.

Mecklenburg,	J. H. Ogburn,	South Hill.
King William,	N. H. Montague,	Palls.
Smythe,	J. M. Hughes,	Chatham Hill.
King & Queen,	R. D. Bates,	Newtown.
Louisa,	J. P. Harris,	Applegrove.
Henrico,	W. J. Lynham,	412 W. Marshall.

East Rockingham, E. J. Carickhoff, Richmond. Harrisonburg.

LOCAL WARDENS IN WYOMING.

Fremont,	Nelson Yarnall,	Dubois.
Uinta,	{ S. N. Leek,	{ Jackson.
	{ F. L. Peterson,	
Carbon,	Kirk Dyer,	Medicine Bow.
Laramie,	Martin Breither,	Cheyen.

LOCAL WARDENS IN TENNESSEE.

Sumner,	W. G. Harris,	Gallatin.
Stewart,	John H. Lory,	Bear Spring.
Robertson,	C. C. Bell,	Springfield.
Montgomery,	P. W. Humphrey,	Clarksville.
Madison,	H. T. Rushing,	Jackson.

LOCAL WARDENS IN NEBRASKA.

Hall,	E. C. Statler,	Grand Island
-------	----------------	--------------

LOCAL WARDENS IN NEW HAMPSHIRE.

Cheshire,	S. C. Ellis,	Keene.
Sullivan,	G. A. Blake,	Lempster.
"	J. W. Davidson,	Charlestown.

LOCAL WARDENS IN VERMONT.

Rutland,	Wm. J. Liddle,	Box 281, Fair Haven
Windsor,	F. A. Tarbell,	West Bridgewater.
Orleans,	E. G. Moulton,	Derby Line.
Essex,	H. S. Lund,	Granby.

LOCAL WARDENS IN ILLINOIS.

Rock Island,	D. M. Slottard,	12th Ave and 17th St., Moline.
Iroquois,	J. L. Peacock,	Sheldon.

LOCAL WARDENS IN OKLAHOMA.

Kiowa and Comanche Nation,	A. C. Cooper,	Ft. Sill.
----------------------------	---------------	-----------

LOCAL WARDENS IN IOWA.

Clinton,	D. L. Pascol,	Grand Mound.
Pottawattamie,	Dr. C. Engel,	Crescent.

LOCAL WARDENS IN WASHINGTON.

Okanogan,	James West,	Methow.
Stevens,	Jacob Martin,	Newport.
"	L. H. Lee,	Northport.
Yakima,	J. Brachmann,	North Yakima.

LOCAL WARDENS IN UTAH.

Washington,	S. C. Goddard,	New Harmony.
"	J. A. Thornton,	Pinto.

LOCAL WARDENS IN KANSAS.

Ness,	Frank Lake,	Ransom.
-------	-------------	---------

LOCAL WARDENS IN FLORIDA.

Brevard,	C. H. Racey,	Waveland.
----------	--------------	-----------

LOCAL CHAPTERS.

Albert Lea, Minn.,	H. A. Morgan,	Rear Warden.
Angelica, N. Y.,	C. A. Lathrop,	"
Augusta, Mont.,	H. Sherman,	"
Austin, Minn.,	G. F. Baird,	"
Austin, Pa.,	W. S. Warner,	"
Boston, Mass.,	Capt. W. I. Stone,	"
Buffalo, N. Y.,	H. C. Gardiner,	"
Cammal, Pa.,	B. A. Ovenshire,	"
Champaign Co., O.,	Hy. F. MacCracken	"
	Urbana,	"
Charlestown, N. H.,	W. M. Buswell,	"
Ch-yenne, Wyo.,	J. Hennessy,	"
Choteau, Mont.,	G. A. Gorham,	"
Cincinnati, Ohio,	B. W. Morris,	"
Coudersport, Pa.,	I. L. Murphy,	"
Cresco, Iowa,	J. L. Platt,	"
Davis, W. Va.,	J. Heltzen,	"
Dowagiac, Mich.,	W. F. Hoyt,	"
East Mauch Chunk, Pa.,	E. F. Pry,	"
Evansville, Ind.,	F. M. Gilbert,	"
Fontanet, Ind.,	W. H. Perry,	"
Ft. Wayne, Ind.,	W. L. Waltemarth	"
Great Falls, Mont.,	J. M. Gaunt,	"
Heron Lake, Minn.,	K. C. Buckeye,	"
Holidays'g, Pa.,	T. J. Hemphill	"
Hopkinsville, Ky.,	Hunter Wood,	"
Indianapolis, Ind.,	Joseph E. Bell,	"
Jerome, Ariz.,	Dr. L. A. Hawkins,	"

Johnsonburg, Pa.,	W. J. Stebbins,	Rear Warden.
Kalispell, Mont.,	John Eakright,	"
Keene, N. H.,	F. P. Beedle,	"
Kingfisher, Okla.,	A. C. Ambrose,	"
Lake Co., Ind.,	Dr. R. C. Mackey,	"
Lawton, O. T.,	Marion Miller,	"
Lincoln, Neb.,	A. J. Sawyer	"
Logansport, Ind.,	E. B. McConnell,	"
Ludington, Mich.,	G. R. Cartier,	"
McElhattan, Pa.,	A. B. Winchester,	"
Mechanicsburg, Pa.,	Dr. J. H. Swartz,	"
Minturn, Colo.,	A. B. Walter,	"
Morgantown, W. Va.,	B. S. White,	"
New Albany, Ind.,	Dr. J. F. Weathers,	"
New Bethlehem, Pa.,	Isaac Keener,	"
Oklahoma City O. T.,	N. F. Gates,	"
Penn Yan, N. Y.,	Dr. H. R. Phillips,	"
Phillips, Wis.,	F. K. Randall,	"
Princeton, Ind.,	H. A. Yeager,	"
Reynoldsville, Pa.,	C. F. Hoffman,	"
Ridgway, Pa.,	T. J. Maxwell,	"
Rochester, N. H.,	Gustave Andreas,	"
" N. Y.,	C. H. McChesney	"
St. Paul, Minn.,	O. T. Denry,	"
St. Thomas, Ont.,	L. J. Hall,	"
Schenectady, N. Y.,	J. W. Furnside,	"
Seattle, Wash.,	M. Kelly,	"
Syracuse, N. Y.,	C. C. Truesdell,	"
Terre Haute, Ind.,	C. F. Thiede,	"
The Dalles, Ore.,	C. B. Cushing,	"
Walden, N. Y.,	J. W. Reid,	"
Wichita, Kas.,	Gerald Volk,	"
Winona, Minn.,	C. M. Morse,	"

DISCOUNTS TO LEAGUE MEMBERS.

The following firms have agreed to give members of the L. A. S. a discount of 2 per cent. to 10 per cent. on all goods bought of them. In ordering please give L. A. S. number:

Syracuse Arms Co., Syracuse, N. Y. Guns.  
 Davenport Fire Arms Co., Norwich, Conn. Shot guns, rifles.  
 Gundlach Optical Co., Rochester, N. Y. Photographic goods.  
 Blair Camera Co., Rochester, N. Y. Photographic goods  
 James Acheson, Talbot St., St. Thomas, Ontario Sporting goods.

LIFE MEMBERS OF THE LEAGUE.

W. D. Ellis, 136 W. 72d street, New York City.  
 A. F. Rice, 155 Pennington avenue, Passaic, N. J.  
 Dr. W. A. Valentine, 5 W. 35th street, New York City.  
 A. A. Anderson, 6 E. 38th street, New York City.  
 A. V. Fraser, 478 Greenwich street, New York City.  
 E. S. Towne, care National Blank Book Co., Holyoke, Mass.  
 F. G. Miller, 108 Clinton street, Defiance, Ohio.  
 Gen. J. F. Pierson, 20 W. 52d street, New York City.  
 E. T. Seton, 80 W. 40th street, New York City.  
 J. H. Seymour, 35 Wall street, New York City.  
 A. G. Nesbitt, Maple street, Kingston, Pa.  
 D. C. Beard, 204 Amity street, Flushing, L. I.  
 C. H. Ferry, 1720 Old Colony Bldg., Chicago, Ill.  
 Hon. Levi P. Morton, 681 5th avenue, New York City.  
 H. Williams, P. O. Box 156, Butte, Mont.  
 D. B. Fearing, Newport, R. I.  
 E. H. Dickinson, Moosehead Lake Me.  
 Lorenzo Blackstone, Norwich, Conn.  
 A. L. Prescott, 90 W. Broadway, New York City.  
 G. S. Edgell, 192 Broadway, New York City.  
 W. B. Mershon, Saginaw, Mich.  
 Hon. H. W. Carey, East Lake, Mich.  
 George Carnegie, Fernandina, Fla.  
 Andrew Carnegie, 2nd, Fernandina, Fla.  
 Morris Carnegie, Fernandina, Fla.  
 W. L. Underwood, 52 Fulton street, Boston, Mass.  
 C. E. Butler, Jerome, Ariz.  
 Mansfield Ferry, 183 Lincoln Park, Boulevard, Chicago, Ill.  
 Austin Corbin, 192 Broadway, New York City.  
 J. Stanford Brown, 480 Fifth Ave., New York City.  
 W. H. Smith, Bryn Mawr, Pa.  
 E. B. Smith, Bourse Bldg., Philadelphia, Pa.  
 A. J. McClure, 158 State street, Albany, N. Y.  
 J. Walter Thompson, Times Bldg. New York City.  
 Clinton Gilbert, 2 Wall St., New York City.  
 E. J. Hudson, 33 East 35th St., Bayonne, N. J.  
 Col. J. C. O'Conor, 24 East 33d st., New York City.

## EARN A GOLD BADGE.

Every member of the L. A. S. should wear the badge, yet thousands of these good men have never yet had one. This is due, in most cases, to neglect. Many a man has come into my office to make a social or business call, and while here has bought a badge, remarking that he had intended to do so ever since he joined the League, but had put it off from time to time.

Here is a chance to get a gold badge for an hour's work and better still a chance to do the cause of game protection a lasting service.

The Executive Committee of the League has decided to give a gold badge to each member who will send in 10 applications for membership, together with a money order for \$10, before January 1, 1904. This gold badge is of itself an ornament that any man may well feel proud of, and its value would be greatly enhanced to anyone who might earn it in the manner suggested. You can get these 10 applications in an hour if you will turn out and hustle.

This offer should bring in 10,000 applications within the next few months. Let us see what it will do.

## BIG HAUL OF DYNAMITERS.

Complaint having been made to the Blair county branch of the League of American Sportsmen at Hollidaysburg that a large number of fish had been dynamited near Cove Forge Tuesday morning by a gang of Italian laborers living near that place, a special officer of the League was sent to the forge yesterday to investigate the matter. As a result 9 men were arrested and taken to Williamsburg, where Judge Charles Patterson sentenced 3 leaders of the gang, Joe Dafonzo, Paul Scuderi and Isaac Denmark, each to pay a fine of \$100 and costs, amounting to \$21, or undergo an imprisonment in the county jail for 6 months. After spending the night in the new borough lockup at Williamsburg the prisoners were taken to jail at Hollidaysburg the next morning, where they now are.

This case, which is the 8th this season in which convictions have been secured by the League, breaks the record for quick work by its officers. Within 48 hours from the time the offense was committed the culprits had begun to serve their sentences of 6 months each in jail.—Altoona, Pa., Mirror.

## PREMATURE FISHING EXPENSIVE.

The Blair county branch of the League of American Sportsmen is determined to break up the practice of fishing trout streams before the opening of the legal season, April 15. Friday of last week G. W. Kough, a prominent citizen of the Northern section of the county, was arraigned by W. H. Gardner, secretary of the branch, before a magistrate of the locality, charged with catching and having in his possession 20 brook trout contrary to the act of assembly. The full penalty of \$200 and costs was exacted from the culprit. Similar violators will please take notice that the law designed for the protection of fish and game will be enforced in this country without fear or favor.—Exchange.

A good wholesome price to pay for premature trout. Kough will probably never

do it again, but all the same his name will go down in the fish hog book and his number is 910.—EDITOR.

## LEAGUE MEMBER APPOINTED.

Mr. Charles L. Miller, who was recently appointed one of the 5 members of the new State Fisheries Commission, is a prominent member of the Blair county branch of the League of American Sportsmen. The League feels much honored by the appointment of one of its leading members to a position of prominence in the counsels of the commonwealth's new commission.—Pennsylvania Paper.

This is another important recognition by a high executive of the good material to be found in this League. The time will soon come when the Governors of the various States will know that one of the primary qualifications of any man seeking an appointment in any fish or game department must be a membership card in the L. A. S.

## LEAGUE NOTES.

In your article on what the League of American Sportsmen had done in regard to new laws stopping the sale of game you omitted Oklahoma Territory. Please give us credit for getting an amendment through last winter stopping the sale on all protected game and cutting off one month on quails.

A. C. Cooper, Fort Sill, Okla.

A reward of \$25 has been offered by the Blair county branch of the League of American Sportsmen for information leading to the arrest and conviction of any person or persons illegally using or operating a seine or using dynamite in any of the waters of Blair county for the purpose of taking, killing or destroying fish in violation of the act of 1901. The penalty for the above offense is \$100 fine and 6 months' jail imprisonment. The informer is also entitled to one-half the fine.—Exchange.

The McElhattan Chapter of the L. A. S. is in a flourishing condition. Every member has been active in getting ready for the coming season and all feel confident that the day of the game hog is past in this locality.

A. B. Winchester, Rear Warden,  
McElhattan, Pa.

There are thousands of men in the United States who should be life members of this League. Why don't they join? Will someone please take a club and waken them?

Have you decided what to send your friends for a Christmas present? Why not a year's subscription to RECREATION? In what other way could you give them so much pleasure for the money?

# FORESTRY.

EDITED BY DR. B. E. FERNOW.

It takes 30 years to grow a tree and 30 minutes to cut it down and destroy it.

## FOREST FIRES.

Last year within 2 weeks over \$12,000,000 worth of timber and other property were destroyed by forest fires in Oregon and Washington. This enormous loss occurred on a restricted area and represents only a small part of the annual loss from this source. Every timbered region of the United States suffers year after year from fire. The annual loss is estimated at \$25,000,000 to \$50,000,000. Forest fires have been regarded as almost inevitable, and few systematic attempts have been made to prevent or control them except in the States of New York, Pennsylvania and Minnesota, which have efficient systems of fire protection.

The Bureau of Forestry has this year undertaken a thorough study of the forest fire problem in several different regions. It has placed men in forest districts to study fires while in the process of burning. Instead of waiting until the fires are over and relying for information on local reports, as has been done heretofore, the fires are now being observed by the Bureau's agents, and full data will be obtained as to how they were caused, how fast they burn, what conditions favor or hinder them, and just what damage they do to the soil and to tree growth. Each agent of the Bureau has been assigned to a district and is investigating all fires that occur within his territory. For example, one man studies a timber tract, another a farming district, a third a turpentine orchard, etc.

By such methods the Bureau of Forestry hopes to replace with carefully gathered facts the vague general notions that now exist about forest fires. When the problem is solved for any particular region, the Bureau will be ready to recommend methods of fire prevention and control for the private land owner and to suggest forest fire legislation for the various States.

A graduate and a special student from the Cornell school of forestry have been in charge of this work.

A report from the Forest Commissioner of Maine, giving estimates of damage of the forest fires in the State during the spring months of this year, which were so unusually drouthy, shows that the damage, as estimated by the fire wardens, has been over \$1,000,000, on over 270,000 acres, which is about 2 per cent of the wooded area. The largest fire swept over 86,000 acres, "on which stood some of the finest timber in the State." It burned with such fury that

on a large part of it the soil was burned, and in some sections the timber was entirely consumed. The causes of the fire were: Eighty-three, unknown; 58 were set by clearing land, 37 by railroads, 17 by fishermen, 12 by smokers, 9 by camp fires, 9 by burning blueberry lands, 4 by river drivers, 4 by hunters, 3 incendiary, 2 by burning brush; lightning, rubbish fire, burning grass, burning old camp, are credited each with one, and porcupine hunters with 17. A law was passed last winter creating a bounty on porcupines, which meets with much disfavor all over the State. Of the fires assigned as 'cause unknown' it is believed that fully one-third were caused by boys and men hunting the porcupine. "The bounty on these animals should be removed and the law repealed at the earliest moment." So says the Commissioner. He also says about the law for the prevention and extinguishment of forest fires which was formulated after the New York State forest fire law: "It will doubtless be found necessary to make some slight changes in this law before it is absolutely perfect, but it is a long step in the right direction and there is not the slightest doubt that it has saved to the State millions of dollars' worth of taxable property, to say nothing of the great saving to the business interests."

## AGRICULTURAL OR FOREST SOIL.

As regards what is to be considered agricultural soil, the only proper gauge is whether a soil can produce more profit by agricultural use or whether it is more profitable to grow timber on it. At present most people will be inclined to think that if a soil can be farmed at all, it is more profitably so used; but as wood prices advance a simple calculation would soon change their position. There is, of course, this difference in farming and forestry; farming furnishes a return every year, while timber must accumulate for a number of years before it becomes available, hence, even poor farming, to the poor man, appears more inviting.

A German agriculturist of note made some pertinent calculations on this subject and found, for instance, that on first class pine soil from which a farmer can net 80 cents an acre rent it is more profitable to farm for the first 30 or 40 years, but after the 40th year a pinery begins to pay better, if interest rate is 3 per cent. Forestry becomes more profitable if the interest rate sinks; less with a rising rate. This is, of

course, due to the fact that during the waiting time for the wood to accumulate compound interest must be charged.

In order to make farming equally profitable with a pine plantation managed in 50 year rotation the farm rent must be at least \$1.28 under similar conditions. To offset the results from a 60 year rotation, the annual farm rent would have to be \$1.51 an acre; and a rent of \$1.61 must be derived annually in order to make farming as profitable as pine growing with a 70 year rotation.

What these calculations show is that profit calculations in forestry are more complicated than is usually realized and that altogether it is the long run that makes forest growing profitable.

#### SEEDLINGS.

It is becoming more and more necessary that a substitute shall be found for spruce in the paper making industry, and it is probable that experiments will show many trees which can be profitably utilized, thus serving the double purpose of keeping the industry alive and saving the spruce from total destruction. The possibilities of straw, corn stalks, and waste from sugar cane, have not yet been exhausted, and the prevention of waste has never had sufficient attention. Spruce has so far established itself as the pulp material *par excellence*, that most manufacturers will hear of no other. Nevertheless poplar, cottonwood, hemlock, and even pine are being used, and for the best paper a blend of other woods is used in connection with spruce. In spite of the present prejudice in favor of spruce pulp, there are signs which point toward the use of other pulps, with no admixture of spruce at all.—Exchange.

The budget of the Prussian Forest Administration for 1902 showed a surplus of \$1,000,000 above that of the preceding year. For the year 1903 the receipts are estimated at \$22,000,000, the expenditures at \$11,300,000. The profit of nearly \$11,000,000 on 7,000,000 acres is secured mainly on a cut of wood of somewhat less than 320,000,000 cubic feet; yet over \$1,000,000 comes from other sources, pasturage, berries, game, etc. In the expenditures, \$60,000 figure for forestry schools and scientific investigations and \$700,000 for extraordinary outlays for the year, mainly for purchase of additional forest lands, the government buying up the waste, deforested lands and reforesting them. The revenues from the forestry department have grown continuously with improved management and the net result per acre is now nearly double what it was 30 years ago.

A process is said to have been perfected in England which vulcanizes, preserves and seasons wood, and makes it extremely hard without brittleness or a tendency to split or crack. It is also claimed that the wood thus treated is impervious to water, and that the treatment is equally efficacious for all kinds of wood. It renders soft woods tough and hard. It includes a boiling in saccharine substance until the pores are filled with solid matter, after which the moisture is evaporated at a high temperature. This treatment takes but little time, and considerable material may be completed and ready for use daily. It is believed that the experiment will help solve the question of the preservation of railway ties.—Forestry and Irrigation.

A number of States are planting trees on waste lands and forming forest reserves. In some cases the work is one of reforestation, and in others it is proposed to make trees grow in regions like the sand hills of Nebraska, which are unfit for agriculture and may be made useful as forested areas.

In most of the New England States there are large areas of waste land coming up in white pine, which, if protected and encouraged, will soon become valuable timber.

Are you making up a list of books for your winter reading? Do not fail to include RECREATION. Nothing else will give you so much pleasure for \$1. If you care for hunting, fishing, photography or nature, you can get more joy out of RECREATION than from any other source except an actual day afield. Send in your subscription and those of your friends.

"How do you do?" said the November Wind, peering through the window at the Beaver Hat.

"First rate," said the Hat. "How are you?"

"Fine!" said the Wind. "Come out and I'll blow you off."—Judge.

An exchange has developed the biggest trust on earth. It is the country newspaper. It trusts everybody, gets cussed for trusting, mistrusted for cussing, and if it busts for trusting, gets cussed for busting. So there you are.

Mary had a little lamb,

Just thirty years ago;

The chops we had for lunch today

Were from that lamb, I know.

—Exchange.

## PURE AND IMPURE FOODS.

Edited by C. F. LANGWORTHY, PH.D.

Author of "On Citraconic, Itaconic and Mesaconic Acids," "Fish as Food," etc.

"What a Man Eats He Is."

### MANDARINS AND KUMQUATS.

At the present time 3 classes of citrus fruits are extensively cultivated in Florida, namely: sweet oranges, pomelos and mandarin oranges. These occupy the first place in citrus culture in the State, although lemons, limes and kumquats are also grown. It is probable that lemon culture will become of considerable more importance than it now is, but at present, and probably for some time to come, the statement, as made above may be allowed to stand.

Of the 3 important classes, sweet oranges occupy the first place and are destined to do so throughout the whole future of citrus culture in Florida. The sweet orange is a staple fruit, just as the apple is. It is always in demand, and it is the dessert fruit *par excellence* of America. Professor Hume, of the Florida Agricultural Experiment Station, has recently published an extended account of the growing of mandarin oranges and kumquats.

Mandarin oranges, also called tangerine and kid glove oranges, are fairly common in most markets. An orange which is found occasionally and will doubtless be better known in the near future is the kumquat, the small oval or round Chinese orange, which is only about as large as a plum.

The mandarin orange, according to Professor Hume, is essentially a fancy fruit, and as such commands a fancy price in its season, but it would be useless to attempt to place it on the same plane with the sweet orange as a staple fruit. The fruit, generally speaking, is smaller than the sweet orange. The bearing capacity of the tree seldom reaches and rarely exceeds 30 boxes and all the members of the group require careful cultivation and fertilization to secure the best quality. Of course, this may be said of sweet oranges or any other citrus fruit, but it is peculiarly true of oranges of the mandarin group.

Mandarin oranges originated in Cochin-China. In 1805 2 varieties were introduced into Europe. The China mandarin, according to the best information which can be secured, was brought to Louisiana by the Italian consul at New Orleans some time between 1840 and 1850. The first trees were planted on the grounds of the consulate at Algiers across the river from New Orleans. It has been impossible to obtain the name of the consul or the exact date. Shortly after, or about 1850, some one of the mandarin oranges was known to North-

ern nurserymen, for Buist, in 1854, refers to one of them as a recent introduction, valuable for pot culture.

The introduction of the China mandarin from Louisiana into Florida is credited on good authority to Major Atway, and not long ago the original tree was growing in an orange grove at Palatka. Mandarin orange culture is on a staple basis at the present time and the number of trees may be conservatively increased.

The introduction of the kumquat orange into Europe appears to have been recent. As far as can be learned it was probably taken to London from China in 1848 by Mr. Fortune, a collector for the London Horticultural Society. Soon afterward it must have been forwarded to America, for there are records of its cultivation by florists in the United States in 1850. The kumquat can not be regarded as anything else than a fancy fruit, and in most cases a demand must be created. The package best adapted for shipping the kumquat is the strawberry carrier. Each quart basket may be lined with fancy fringed paper and the whole crate should also be lined with heavy paper. It is the usual custom to fill each basket level full of the fruit and place a small twig on top with one or 2 oranges attached. Sometimes the fruits are all cut with one or 2 leaves and are attractive and ornamental. Professor Hume states that cut and packed as indicated they have frequently brought 75 cents to \$1 a quart. It may, however, be stated that the demand is not unlimited and heavy shipments should not be made at any one time. The price usually obtained in 1902-3 was 25 cents a quart. Forty or 50 fruits fill a quart basket, but if the fruit is cut with leaves attached this number is considerably reduced.

The kumquat may be eaten raw, and when served in small glasses holding 3 or 4 fruits they make a pretty addition to the table. If cut with leaves attached they may be used as table decorations. In eating the fruit the skin is not removed, and the spicy, aromatic rind and acid pulp make a delightful combination. An excellent preserve can also be made from the fruit, and the Chinese export considerable numbers put up in small stone jars or in tins. Large numbers of kumquats are also dried in sugar or crystallized, and in this form are fairly common as a confection.

The following recipe for preserving the kumquats, Professor Hume states, has been

tried and has proved satisfactory: Boil 4 parts sugar and 3 parts water in a preserving kettle 5 minutes. Place selected fresh fruit of uniform size and ripeness in the boiling syrup and boil briskly an hour and a half. Do not allow it to simmer or the rinds will become tough. Remove from the fire and seal at once. A pint of fruit, 2 cupfuls of sugar and a cupful and a half of water make about a quart of preserves.

Kumquat oranges are often grown in pots and are unsurpassed by any other species as a useful ornamental plant.

#### FOOD IN CANS AND PACKAGES.

The question of food adulteration is of special importance in the Northwestern United States, for there one must depend on canned goods and such materials more than in other regions for a large part of the food supply. Much of the food for miners, herders and ranchmen must be preserved in some way for storage and transportation, and most of the towns have extensive suburbs of tin cans. The prevailing use of foods in packages and cans, while it prevents the personal supervision insuring purity and cleanliness, which is easy where the markets are supplied from the immediate neighborhood, makes the general supervision and control of food products easier than elsewhere.

According to Professor Slosson, of the Wyoming Experiment Station, the prices paid in that State for foods are high, and most employers pride themselves on sending out the best foods in the market to their herders or gangs of workingmen. Unfortunately, the results do not often match their good intentions, for it is assumed that the highest priced, most extravagantly advertised, and brightest colored food products are the best, and this is by no means the case. Some of the firms which are most vociferous in talking of pure foods, and in warning against imitations, are really responsible, he believes, for the worst goods on the market.

"All enjoy reading the attractively written and handsomely illustrated advertisements which fill the magazines, and we have a right to, for we pay for them when we buy the wares. A manufacturer sometimes sends out part of his product at a high price under a name which, by expensive advertising, has become a household word, and puts the same quality of food on the market, without his trademark, for sale at a much cheaper rate. The price of food products affords almost no indication of their purity or real value.

"Most of the States have more or less stringent pure food laws, and since all effort to get a national law through Congress has thus far failed, there has been a tendency to unload poor or adulterated goods on

those States which have not been so protected. Hitherto, honest dealers in this State have been at a disadvantage, because, while they personally wished to handle a high grade of goods, they have been obliged to meet the prices of less scrupulous competitors; and the public, in purchasing, considers only cheapness, appearances and taste."

The Wyoming Legislature has recently passed a law regulating the sale of foods, drinks, drugs and illuminating oils. The law does not restrict the sale of any proper food or drink, but aims to prohibit the addition of ingredients manifestly injurious to health, and to insure that all foods, drinks and drugs are truthfully labeled. The chemical supervision of foods has become so vigilant that there are comparatively few poisonous substances in use as adulterants, and it is surely working no hardship on manufacturer or packer to require him to inform the customer what he is buying and eating. Since the foods likely to be adulterated are almost altogether imported into Wyoming, the pure food law should in that State be practically self-enforcing.

#### MOCHA COFFEE.

"During the past few years I have often heard the assertion made and have seen it in the newspapers in our country that there was no such article as Mocha coffee," writes W. W. Masterson, the American Consul at Aden, the port from which Mocha coffee is shipped. "It is frequently stated that the term is purely a fiction, and that what was once known as Mocha coffee is so mixed with other coffees that there is no longer a real Mocha.

"In order to help correct such an impression and to do the coffee merchants of this place and the importers in our country an act of justice, I wish to say that there is such an article to-day in the American market as Mocha coffee, that this coffee is of the same kind and from the same place as the noted Mocha coffee of several generations ago, and that the growers and handlers of this coffee are as particular in regard to its quality and purity as they ever were.

"At different times merchants have tried to ship coffee from other countries to this place and forward it from here as genuine Mocha, but the city authorities have always suppressed such traffic and have otherwise assisted the merchants in keeping up the standard and good name of this coffee.

"Knowing of the carefulness with which the coffee interests are managed and the government's protection over it, I am of the opinion that if by the time the consumer gets his Mocha coffee it is not pure, the mixing has been done after it leaves Aden."



## EDITOR'S CORNER.

### SHALL WE ALLOW AUTOMATIC GUNS?

Several patents have recently been issued for automatic shot guns, and I am informed that the Winchester Arms Co., of New Haven, Conn., is building machinery to make such a gun. Another gun house has already brought out one, and it is now being advertised and sold.

It would seem that reasonable men, no matter how eagerly they may seek the mighty dollar, should be satisfied with the weapons already on the market for destroying American birds and wild animals.

We have repeating rifles, repeating shot guns, double barrel and single barrel shot guns by the million, and with these the birds and the wild animals have been reduced to pitiable remnants of their once great numbers; but now, as if not satisfied with the slaughter which has been and is being carried on, these big gun houses are putting out still more murderous engines of destruction, for market hunters and pot hunters.

This announcement should arouse the indignation of every decent sportsman and every nature lover on the continent, and I appeal to all such to write at once to the Winchester Arms Co., protesting in the strongest and most vigorous language possible,

against the making and putting on the market of an automatic gun.

Many people who have not kept up with the developments of recent years, in the way of fire arms, may not know what is meant by an automatic gun. It is simply this:

A gun with a magazine holding a number of cartridges which may be discharged as fast as a man can pull the trigger. The shooter jumps a bunch of quails, ducks or geese, cocks his gun and fires. The recoil of the first shot throws out the empty shell, throws a new one into the chamber and cocks the gun, ready for another shot. From that on, all the shooter has to do is to swing the muzzle of his gun from one bird to another and pull the trigger until the last shot is fired. Pistols built on this plan hold 7 to 10 cartridges, and it is possible to fire all of them in less than 2 seconds. The magazine of an automatic shot gun, holding 6 cartridges, could be emptied as quickly, and if the shooter were an expert, as many of the game butchers are, it would be possible to kill 10 or more birds out of a covey before they could get out of reach.

The repeating rifle has been an important factor in wiping out the big game of this country. The pump gun, so called, has proven little short of a national calamity. An automatic shot

gun would be a disgrace to the nation, and its introduction should be prohibited by law. This may not be, but the sale of any such weapon, to decent men, can be prevented by the creation of a proper public sentiment.

I appeal to all readers of RECREATION to write at once to the company mentioned, stating that they will never buy or use an automatic gun; that they will discourage its use by others in every legitimate way; and that they will not associate with any man who may use such a weapon.

Will every woman who loves the birds write and protest, in the name of decency and of humanity, against the making and selling of any such weapon?

Here is a chance to strike a telling blow for the protection of our birds, and I trust no friend of the birds or the wild animals will let the opportunity pass, no matter how busy he or she may be. When you write this company send me a copy of your letter, in order that I may print as many such protests as possible.

---

#### A JURYMEN IN THE JUG.

As stated in September RECREATION, Chris McLain, his son and 3 other men were discovered by Game Warden B. B. Spafford, of Cadillac, Mich., spearing fish at night in a lake near Frankfort. Spafford ordered the men to surrender, when McLain attacked him with a spear and Spafford shot and killed McLain. Spafford was arrested, charged with the killing, and claimed that he fired in self defense. He was, however, convicted of manslaughter and released on bail, pending sentence.

Now comes the sequel. R. M. Thomas, of Thompsonville, Mich., was impaneled as

one of the jurymen to try Spafford and in common with the other 11 men was placed under oath and asked whether he had formed or expressed any opinion as to the guilt or innocence of the accused. He replied that he had not, and that he could legally sit on the jury and render an impartial verdict. After the trial, neighbors informed Game Warden Brewster they had heard Thomas express the opinion that Spafford was guilty of murder. One man, a banker, swore Thomas had said in his presence that Spafford should be sent over the road and that he, Thomas, would like to sit on a jury to send him to hell.

Other of Thomas' neighbors made similar affidavits and as a result, Game Warden Brewster arrested Thomas on a charge of perjury. At the present writing, there is an excellent prospect that Thomas will get quarters at the prison he tried to send Spafford to. Meantime, Governor Bliss has pardoned Spafford.

There is among the farmers of Michigan, as among those of many other States, a great deal of hostility to the game laws. Much of this is due to ignorance of the real value of living wild animals and birds to the farmers. Many of these men want the privilege of killing game at any time of year. Still, when a man becomes so bitter in his opposition to game laws that he will swear to a lie in order to get on a jury to send a game warden to prison, he is carrying his opposition about an inch too far, and I hope Thomas may get at least 5 years.

---

#### SHALL I PRINT MY OWN STORIES?

When I established RECREATION, 9 years ago, I determined not to write anything for it other than short editorial paragraphs, and only such of these as conditions might render necessary. I told my friends I should not burden them with any long winded stories of my own, but that I should let other people do all the talking of that class. I adhered to this rule strictly until a year ago, when I visited the Selkirk mountains and made a study of the snow slides that occur there. I made a lot of photographs of them and wrote an article, with the intention of selling it to some other publisher; but in talking of the subject with some of my friends, they persuaded me, against my own judgment, to print the article in RECREATION. Much to my surprise, however, few of my readers objected, and some of them even claimed to be pleased with the story. A few have gone so far as to ask me to do it again.

And I have done so.

I spent all of last summer in the Canadian Northwest, flitting about among the high tops of the Continental Divide. Of

It is easy to claim "pure beer," but one must double the cost to make it.

Schlitz is actually pure.

We go 1400 feet down for water.

We spend fortunes on cleanliness.

We not only filter the beer, but filter all the air that touches it.

We age the beer for months, so it cannot cause biliousness. We Pasteurize every bottle after it is sealed.

For fifty years we have insisted on purity, and now all the world knows it. The result is a sale exceeding a million barrels annually.

Isn't absolute purity as important to you as to others?

*Ask for the Brewery Bottling.*



course I carried a camera with me and made many valuable pictures. While I have not written any detailed account of the trip, I have written several special articles. One of these deals with my experiences in photographing, another contains observations on the habits of certain wild animals and birds I found there, another treats of the *personnel* of our pack trains, etc. Some people who claim to be good friends of mine, and who profess a deep interest in the success of RECREATION, are advising me to print these stories in RECREATION, and unless I get a good many protests in the near future, I may venture to publish a few of them. I could sell all these stories readily, to other magazines, and at good prices; but, as the politicians say, I am in the hands of my friends, and my only ambition is to do as they wish me to do.

Now, gentlemen, don't hesitate to speak out. If you don't want these articles printed in RECREATION, say so, and they will go elsewhere, by special messenger.

#### ELK AND MOOSE TO THE SLAUGHTER.

Mr. W. C. Whitney has sent his entire herd of elk, 80 animals in all, to various points in the Adirondacks, where they have been liberated. I regard this as a serious mistake on Mr. Whitney's part. It is casting pearls before swine. It will be remembered that some 2 years ago a moose escaped from one of the Adirondacks preserves, probably Dr. Seward Webb's, and that a low vagabond who lived in the vicinity killed it.

When arrested and charged with the killing, he swore he saw the animal lying down and thought it was a bear; that he fired at it; that it got up and took after him; that he ran until almost exhausted, and then turned and killed the animal in self defense. Any man who knows anything of the nature of the moose, knows that man swore to a lie.

The newspapers have recently reported the killing of 3 elk in the Adirondacks by some men who claimed to have mistaken them for deer. At last accounts these men had not been arrested. If they should be at any future time they will, of course, perjure themselves, as the moose killer did, and escape punishment.

So it will go with all these grand animals that Mr. Whitney has donated to the public, and with any other elk or moose which have been or may be liberated in the Adirondacks.

There are some good honest guides in the Adirondacks. They know who the other fellows are that are killing off the elk and moose and should see that it is stopped.

If the fool killer would only do his duty and exterminate the pot hunters and the game hogs, in the Adirondacks and elsewhere, it would then be safe to stock that region with moose and elk. In the meantime all efforts in that direction are simply

in the nature of giving up these magnificent animals to slaughter.

The Kodak recently played a unique and important part in the conviction of one Horace Lydick, of Cass Lake, Minn., for killing a moose in close season. It is reported that June 19th, last, Lydick and a man named Kennedy were going down the Big Fork river in a canoe. They saw a cow moose and a calf on the bank of the river and opened fire on them, killing the cow. Noah Fletcher and S. C. Farwell were in the vicinity and had sighted the game about the same time. Fletcher was stalking the cow with his camera. When he was nearly ready to press the button on her, 4 shots rang out, 4 bullets whizzed past him and the cow fell, floundering in the water. He went up to her, made a snap shot of her, and by that time the hunters landed. They pulled the carcass ashore and commenced chopping it up, when Fletcher exposed another plate on the group. Game Warden Sam Fullerton heard of the transaction and sent deputy game warden Archie Phillips, of Duluth, after the moose butchers. Lydick was arrested, taken into court and placed on trial. Mr. Fletcher was there as a witness and produced his 2 photographs. That settled the business and Lydick was fined \$100 and trimmings.

I have before me a letter from W. F. Spencer, of Wilson, Wyo., dated July 25, 1903; one from Noble Gregory, of Elk, Wyo., dated July 14; and one from Wm. Binkley, of Grovont, Wyo., dated July 19, 1903, in which these men offer to sell to their correspondents elk teeth at certain prices which they quote. Wyoming has a law prohibiting the sale of any part of an elk at any time, yet these men, one of whom poses as a guide, and is therefore a deputy game warden, are deliberately seeking chances to violate this law. Game Warden Nowlin should watch these men closely and I hope if either of them ever sells a tooth, he may be caught and punished to the full extent of the law.

One of the so called "great" magazines published in this city prints an article in its November issue lauding the prowess and skill of the Duchess d'Uzes, of France, who, that magazine says, has recently been in at the death of her eleven hundredth stag. The writer of the article lauds this aristocratic butcher as "France's first huntress," and praises her exploit as if she were a modern saint.

In the same issue of the same great magazine appears another article, commending the good, wholesome game laws that have recently been enacted by the Legislatures of several of our States. Rather inconsistent, eh?

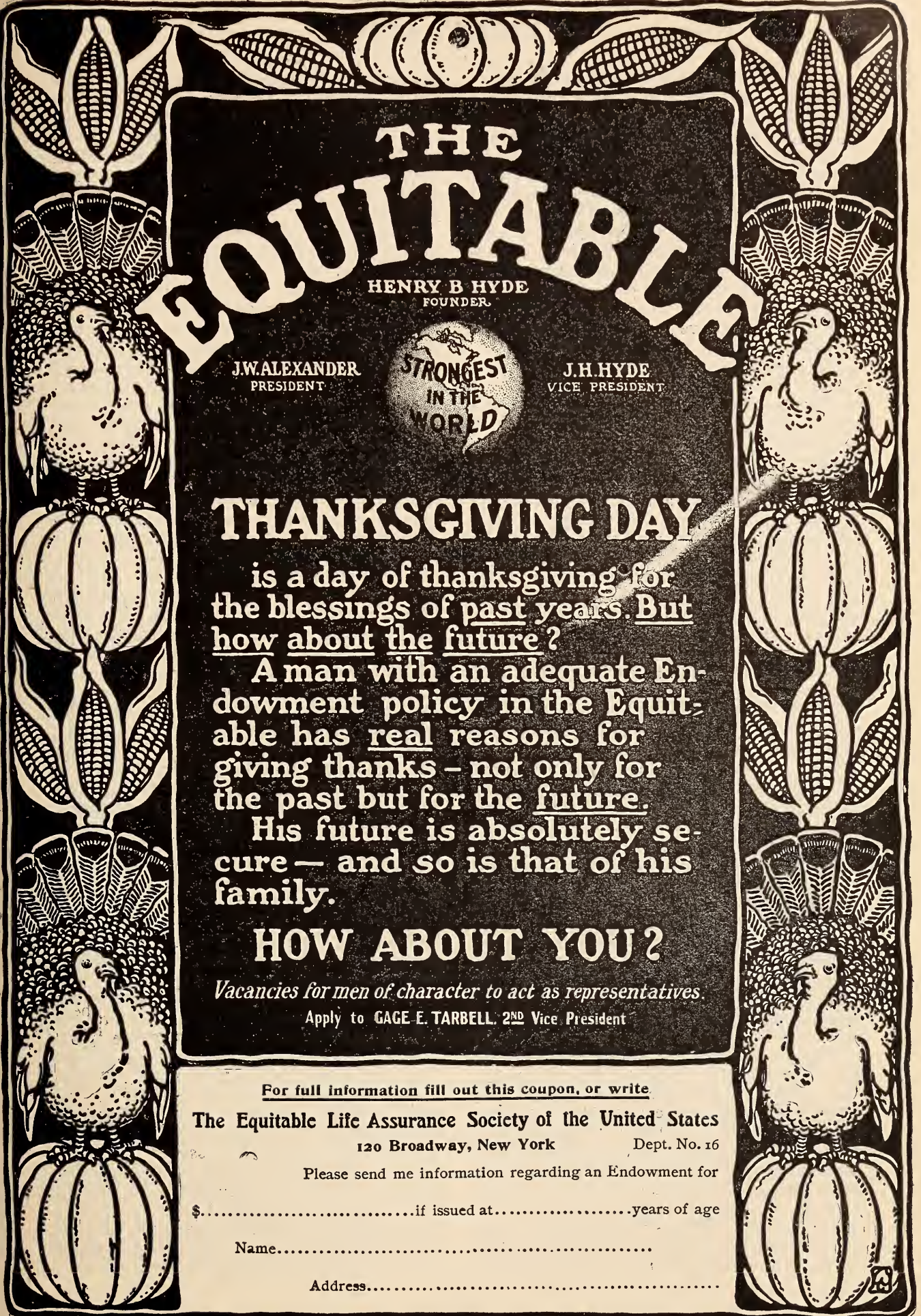

# THE EQUITABLE

HENRY B HYDE  
FOUNDER

J.W.ALEXANDER  
PRESIDENT

STRONGEST  
IN THE  
WORLD

J.H.HYDE  
VICE PRESIDENT

## THANKSGIVING DAY

is a day of thanksgiving for the blessings of past years. But how about the future?

A man with an adequate Endowment policy in the Equitable has real reasons for giving thanks - not only for the past but for the future.

His future is absolutely secure - and so is that of his family.

## HOW ABOUT YOU?

*Vacancies for men of character to act as representatives.*

Apply to GAGE E. TARBELL, 2<sup>ND</sup> Vice President

For full information fill out this coupon, or write

The Equitable Life Assurance Society of the United States

120 Broadway, New York

Dept. No. 16

Please send me information regarding an Endowment for

\$.....if issued at.....years of age

Name.....

Address.....

## PUBLISHER'S NOTES.

### MOUNT YOUR OWN HEADS.

Nearly every sportsman kills many animals and birds the skins or heads of which he would like to preserve; yet there are many men who do not know how to take off and preserve the skins. Many such men live a long way from the nearest taxidermist, and the expense of sending the skins to a shop and getting the specimens properly mounted, deters the hunter from undertaking the work. There are many other men who feel that they can not afford the expense of having specimens mounted, and many such have wished they knew how to mount skins or heads themselves.

This want is being supplied in full measure by the Northwestern School of Taxidermy, at Omaha, Neb. Prof. J. W. Elwood, in charge of this institution, is a thorough, practical, sportsman, a naturalist, taxidermist, and a straight forward, reliable business man.

He has prepared a series of lessons in taxidermy, including the taking off and preserving of skins, which he teaches by mail. Then by his system of correspondence he conducts these lessons, criticises the work submitted to him, and in a thoroughly practical way teaches his pupils how to do such work.

This school has been in existence for some time, and now has on its rolls several hundred students.

These people commend Prof. Elwood's methods in strong terms, and it would certainly be of great interest to all nature lovers, who desire to preserve specimens of birds and animals, to communicate with Mr. Elwood and to take a course of lessons under him.

I do not mean by this to encourage in any way the reckless slaughter of birds and animals simply for the purpose of making up collections of skins. Every good man and boy deprecates any such a course; but to whatever extent birds and mammals may be killed in a legitimate and sportsmanlike way, their skins and heads should be saved; not only for the benefit of those who killed them, but for the public at large, and for posterity. The time will come when nearly all species of wild birds and animals will be extinct on this continent except in preserves. Let us postpone this evil day as far as possible, and in the ages to come when men shall read of these wild creatures that once inhabited this fair land, they will at least have an opportunity to see specimens of them.

### TWO MORE NEW BOOKS.

Buzzacott, the camp and sportsmen's outfitter, has written 2 more books, which are

about ready to issue from the press. They are entitled the "Complete Fishermen's and Anglers' Manual, or, How to Catch Fish," and the "Complete Hunters' and Sportsmen's Manual, or, Trappers' Guide." Each volume contains 136 pages and over 200 illustrations, exhaustively covering the subject named.

Buzzacott, it will be remembered, is the author also of the "Complete Campers' Manual, or, How to Camp Out; What to Do," which has received the unstinted praise of many thousands of readers, both in Europe and America. The sale of this book has reached 50,000 copies in 4 months.

A copy of either of the books mentioned will be mailed to any address in the world on receipt of 10 cents, coin or stamps; or the 3 books, bound in one volume, 408 pages, 600 illustrations, for \$1. Sportsmen who fail to order copies of these most valuable and instructive books miss the opportunity of a lifetime, as the information they contain is worth 10 times the price. Address the author, Buzzacott, Chicago, Ill.

### A RUST PREVENTIVE.

There are many brands of so called gun grease, or gun oil, on the market, but none of these have proven entirely satisfactory. A new one has just made its appearance, which seems to be exactly right in every particular. This is Cedaroleum, made by the Cedaroleum Co., Perkinsville, Vt. This lubricant is in the form of a thin paste, having some of the qualities of vaseline, and yet it is thin and entirely different in character from that substance. Cedaroleum has a good body and good staying qualities; yet it is sufficiently volatile to be easily spread over a large surface. It leaves a heavy coat, which certainly must prove impervious to atmosphere, to salt air, or to changes of temperature.

Cedaroleum is put up in collapsible tubes and one of the most attractive features of the scheme is that each tube is fitted with a long, slim nozzle, having a screw cap. On removing this cap you have an injector, which can be passed into your gun lock, or into the muzzle of even a 22 caliber rifle. Then by squeezing the tube you can put the oil where it will do the most good. Cedaroleum sells at 15 cents a tube and is sent by mail postpaid. If you write for sample please mention RECREATION.

### PROCTOR IN MONTREAL.

The success achieved by F. F. Proctor since his entry into Montreal as a theatrical manager is a source of surprise to most Americans, who for many years have had a strong suspicion that Yankees were not par-

ticularly welcome as theatrical managers on the other side of the border line. Mr. Proctor's energetic and progressive method of advertising, his liberality in putting forward good shows at low prices, and his well known ability to do business along sound commercial lines, all combined first to surprise, then delight the Canadian public. As a result, his theatre in Montreal, the handsomest and largest, in the Dominion, by the way, has now firmly established itself in the favor of the Canadian public. In fact, Proctor's is as much a household word across the line as it is in these parts.

One characteristic of the Korona cameras which the manufacturers have kept persistently before the public is that expressed in the well known saying, "It's all in the lens." Moreover, the standard of the optical equipment of Korona cameras has been maintained on a sufficiently high plane to justify the emphasis which the Gundlach-Manhattan Optical Company places on this feature. It is an old saying that imitation is the sincerest flattery, and it is therefore an amusing tribute to the publicity which the Korona has gained, to find "It's all in the lens" variously twisted into: "It's 98 per cent in the lens," "It's not all in the lens," etc. The original phrase is so good that other advertisers do not seem able to keep their hands off.

The Baker Gun and Forging Company, of Batavia, N. Y., makers of the celebrated Baker Gun, published in the August number of their Quarterly a great deal of material of special interest to sportsmen. In addition to full descriptions of their various patterns of guns, several pages are devoted to a review of the principal shooting events of the first half of this year, articles on duck shooting and an interesting article on the subject of shot, illustrated with diagrams and original matter on this subject not heretofore printed by any similar publication. The Quarterly is sent free to any address on receipt of postal card.

The DuPont Powder Co., of Wilmington, Del., write me that they have had a great many inquiries for their book, "Brush, Stubble and Marsh," of which I printed a notice in RECREATION some months ago, and they request me to say that they have adopted a rule under which they can send this book only to persons who enclose 6 cents in stamps to pay postage. The book is a rare work of art, and many of the pictures reproduced in it are worth cutting out and framing. Any lover of outdoor sport should

be glad of the chance to get so fine a book as this by merely paying postage on it.

"The Korona and the Film Pack" is the title of an artistic folder issued by the Gundlach-Manhattan Optical Co., which announces that the well known Film Pack can now be used with Korona cameras. By means of this device, the field of usefulness of the Korona is greatly enlarged, and it is thereby converted into a focusing film camera. We advise those who own Koronas, and those who contemplate the purchase of a new camera, to send to the Gundlach-Manhattan Co. for the new folder.

F. W. Bird & Son, East Walpole, Mass., make a roofing paper that should be known to every person who intends to build a house, or a barn, or a boat house, or a camp in the country. I have used some of this paper on the buildings of the Mashipacong Club, in Sussex county, N. J., and have found it admirably adapted to such purposes as I have mentioned.

By writing to the company as above and mentioning this notice you can get samples of the paper and full information as to the prices, manner of putting on, etc.

I am informed by several people who have sent money to the Hub Poultry and Supply Company, of Boston, Mass., that these people are frauds, and it appears that they have discontinued business. Letters that have recently been sent to the address they gave have been returned not delivered.

Hemm & Woodward, Sidney, Ohio, have reduced their price on wick plugs. See their new ad in this issue of RECREATION.

These wick plugs are the greatest things ever invented for keeping a gun clean inside, and every shooter should have a supply.

Readers of RECREATION who buy at the news stands, and who may at any time find circulars or other printed matter inserted between the leaves by news dealers, are requested to take out and send to me all such inserts.

The Irishman was wrestling with a mathematical problem too great for his mental faculties. "The 2 Grogans was wan, Pat Flynn was 2, meself was 3. Bedad, I thought there was 4 of us. Pat Flynn was wan, meself was 2, and 2 Grogans was 3—meself was wan, the 2 Grogans was 2, Pat Flynn was 3—there was but 3 of us after all."—Judge.

## AMATEUR PHOTOGRAPHY.

"For sport the lens is better than the gun."

*I wish to make this department of the utmost use to amateurs. I shall, therefore, be glad to answer any questions and to print any items sent me by practical amateurs relating to their experience in photography.*

## 8th ANNUAL COMPETITION.

RECREATION has conducted 7 amateur photographic competitions, all of which have been eminently successful. The 8th opened April 1st, 1903, and will close November 30th, 1903.

Following is a list of prizes to be awarded:

First prize: A Long Focus Korona Camera, 5 x 7, made by the Gundlach Optical Co., Rochester, N. Y., fitted with a Turner-Reich Anastigmat Lens, and listed at \$85.

Second prize: A No. 3 Folding Pocket Kodak, made by the Eastman Kodak Co., Rochester, N. Y., fitted with a Bausch & Lomb Lens, Plastimat Unicum Shutter, and listed at \$61.50.

Third prize: A Royal Anastigmat Lens, 4 x 5, made by the Rochester Lens Co., Rochester, N. Y.; listed at \$36.

Fourth prize: A Waterproof Wall Tent, 12 x 16, made by Abercrombie & Fitch, New York, and listed at \$32.

Fifth prize: An Al-Vista-Panoramic Camera, made by the Multiscope and Film Co., Burlington, Wis., and listed at \$30.

Sixth prize: A No. 3 Focusing Weno Hawkeye Camera, made by the Blair Camera Co., Rochester, N. Y., and listed at \$27.50.

Seventh prize: A high grade Fishing Reel, made by W. H. Talbot, Nevada, Mo., and listed at \$20.

Eighth prize: A Tourist Hawkeye Camera, 4 x 5, and made by the Blair Camera Co., Rochester, N. Y., and listed at \$15.

Ninth prize: A Bristol Steel Fishing Rod, made by the Horton Mfg. Co., Bristol, Conn., and listed at \$8.

Tenth prize: A pair of High Grade Skates, made by Barney & Berry, Springfield, Mass., and listed at \$6.

The 10 next best pictures will each be awarded one dozen 8 x 10 Carbutt Plates, made by the Carbutt Dry Plate Co., Wayne Junction, Philadelphia, Pa.

The 10 next best pictures will each be awarded one dozen 5 x 7 Carbutt Plates.

The 10 next best pictures will each be awarded one dozen 4 x 5 Carbutt Plates.

A special prize: A Goerz Binocular Field Glass, listed at \$74.25, will be given for the best picture of a live wild animal.

Subjects are limited to wild animals, birds, fishes, camp scenes, and to figures or groups of persons, or animals, representing in a truthful manner shooting, fishing, amateur photography, bicycling, sailing or other form of outdoor or indoor sport or recreation. Awards to be made by 3 judges, none of whom shall be competitors.

Conditions: Contestants must submit 2 mounted prints, either silver, bromide, platinum or carbon, of each subject, which, as well as the negative, shall become the property of RECREATION. Negatives not to be sent unless called for.

In submitting pictures, please write simply your full name and address on the back

of each, and number such prints as you may send, 1, 2, 3, etc. Then in a letter addressed Photographic Editor, RECREATION, say, for instance:

No. 1 is entitled — — —.

Made with a — — — camera.

— — — lens.

On a — — — plate.

Printed on — — — paper.

Length of exposure, — — —.

Then add any further information you may deem of interest to the judges, or to other amateur photographers. Same as to Nos. 2, 3, etc.

This is necessary in order to save postage. In all cases where more than the name and address of the sender and serial number of picture are written on the back of prints I am required to pay letter postage here. I have paid as high as \$2.50 on a single package of a dozen pictures, in addition to that prepaid by the sender, on account of too much writing on the prints.

Any number of subjects may be submitted.

Pictures that may have been published elsewhere, or that may have been entered in any other competition, not available. No entry fee charged.

*Don't let people who pose for you look at the camera. Occupy them in some other way.* Many otherwise fine pictures have failed to win in the former competitions because the makers did not heed this warning.

## WHY THE AMATEUR SHOULD USE PYRO.

Pyro is the best developing agent we have for plates. The substantiation of this premise I will leave to those who make a business of photography. Look over the directions given for making developers, and for the development of plates, issued by the plate makers, who pay large salaries to expert chemists to find out just what formula gives the best result with their plates. Note how the preference is always given to pyro. You may be sure these men know what they are about. Did you ever see a demonstrator traveling for the large dry plate concerns use anything but pyro? At present competition is so sharp, and the demands and investigations for new and better methods so numerous, that only those who keep abreast of the times and do the most acceptable work succeed. Of these I believe fully 99 per cent use pyro.

The negative is only one step in the process of making the finished photograph; we are not striving for a pretty negative, but one which will give us the best print. This the use of pyro does by imparting to the films an organic stain which can be varied at will by the quantity of sulphite in the developer. It is just this printing-quality imparted to negatives by pyro that



makes it of greatest value to the amateur. The majority of negatives made by amateurs are under exposed and consequently thin, but is it surprising what good prints can be made from these thin pyro negatives in comparison with the blue black negative of little density made with almost any of the newer agents.

The behavior of the negative in the fixing bath is also to be considered. How much of the density is going to fix out? With pyro very little, but with some of the other developers, edinol, for example, much of the density will afterward disappear, so that it is necessary apparently to over develop. This guessing at how much to over develop does not lead to uniformity of results. Advertisers tell us to use metol for a soft working developer, hydroquinone for the reverse, and ortol for a little of both and not too much of either effect. Pyro is hard or soft working, contrasty or not, according to the way it is handled. Concentrate your developer enough and you can get a cast iron negative; weaken it and all the softness required can be obtained. This flexibility is a great convenience, doing away with a multiplicity of solutions.

Pyro is almost universal in its application, with the exception of the developing papers, and some special uses, such as process work, etc. If a 3 solution developer is used it can be varied at will to fit the formula given for any make of dry plates. It is best to settle on one developer and then learn how to manage it so as to obtain the best and most uniform results.

Pyro is cheap. One ounce of pyro costs 15 to 25 cents and will make 166 ounces of developer of 3 grains of pyro to the ounce. One ounce of metol, ortol, glycin or edinol will cost 60 to 75 cents, and will make 100 to 200 ounces of developer. I hear someone say that he can use pyro only once and these others can be used over and over. True, but the negatives show a correspondingly increasing apparent under exposure for each additional time the solution is used.

The response to potassium bromide added in cases of known over exposure is definite and satisfactory with pyro. With some of the other reducing agents it works most actively, while with others, metol for instance, little response is obtained.

The chief objection I have heard to pyro is the staining of the hands, and it does do this most beautifully. I find that using citric or tartaric acid, or sodium sulphite and sulphuric acid, immediately on finishing development, removes the greater part of the stains. Rubber gloves and finger cots can now be found so thin that the sense of touch is little interfered with, and by their use no stains are possible,

so this greatly talked of objection can be obviated. To my mind there is no comparison between a good negative and stained hands, and a miserable, washed out piece of glass and hands which would delight the latest *debutante*.

R. L. Wadhams, M. D., Wilkesbarre, Pa.

#### DO IT YOURSELF.

The beginner in photography soon finds that it is an expensive amusement, the more so if he belongs to the army of button pushers who are content to let some one else do the rest.

If the amateur will take the trouble to keep a memorandum of his expenditures for a month or 2 he will find that the cost of plates to him alone is a small part of the total amount, and that the greater part of his outlay goes to the man who does his developing and printing.

For the beginner it is perhaps as well at first to call on the professional finisher for help in this part of the work, for the problems of exposure, lighting, etc., will give plenty of material for thought and study without troubling with the equally important subjects of development and printing. But as soon as the tyro has learned what to expect of his camera, what may be taken and what can not be secured, by all means let him learn to do the rest.

By this means not only will greater enjoyment be gained from the hobby, but what is equally or perhaps more important to most of us, the cost of the amusement will be greatly reduced.

Lack of equipment need not trouble one, for if you are really in earnest you will find some way of providing the necessary utensils and a place in which to use and keep them. The kitchen or bathroom will serve as a dark room if used only at night, and the necessary trays and ruby light will cost little.

As to the latter, I have found that the most satisfactory light is obtained by placing a small kerosene lamp inside a good sized wooden box in one side of which is set an 8x10 light of ruby glass. The box should be about one foot square and 18 inches high, and should have a door on one side large enough to admit the lamp. Holes bored in top and bottom, over which pieces of tin are loosely placed, allow a circulation of air through the box without allowing any light to escape. I advise you to buy the necessary chemicals and mix your own developer, fixing bath, and all the other solutions which you may need.

You will need to invest in a pair of small scales and a measuring glass, but the money expended for these articles will soon be saved by compounding your own solutions. No expert knowledge of chemistry is re-

quired to enable one to make up any of the solutions used in photography. It is simply following a formula, so much of this and so much of that.

In mixing a developer use at first the formula given by the maker of the plates you are using, and stick to it until you can use it successfully. Not until then should you begin to experiment. Having the means and materials at hand for mixing a variety of formulæ, it is natural that one should wish to try every new developing formula that comes to hand, but if you wish to turn out satisfactory work, resist the temptation and stick to your one developer until you have mastered it.

Not that I would discourage the trial of new methods and new formulæ, for this is to many one of the greatest pleasures in photographic work, but one should be sure of a few things before attempting to do too much in the way of experimenting.

In the matter of chemicals, buy them in bulk, that is to say, in as large quantities as you can use in a reasonable length of time. Buy hypo in 5 or 10 pound lots, sodium sulphite and carbonate by the pound, and pyro, metol, or whatever it may be, by the ounce. When your chemicals are purchased in this way, you will find that the cost of solution is surprisingly small, to say nothing of the fact that they are always freshly mixed and of known strength.

If once you begin working in this way, I am sure you will never go back to the professional, but will find increasing pleasure and satisfaction in "doing the rest" yourself.

C. M. Whitney, Bayonne, N. J.

#### THE SEPARATE BATH AND ITS USE.

Please give me full directions for preparing and using the separate toning bath.

Will a portrait lens, placed over the regular lens, take pictures of landscapes and buildings?

A. E. S. Roth, Prairie du Chien, Wis.

#### ANSWER.

The toning bath should be mixed one hour prior to use in order to allow it to ripen. To 48 ounces of water add one grain of chloride of gold, then immerse a piece each of red and blue litmus paper. While stirring the bath add 3 or 5 drops of a saturated solution of borax, or a sufficient quantity to cause neither the red nor blue litmus paper to change color. In this condition the bath is neutral and in prime order for toning prints. At a safe distance to avoid contamination of other solutions mix your fixing bath, 25 degrees hydrometer test, and to each gallon of solution add one-half ounce of solio hardener. After thoroughly cleansing your hands from any trace of hypo, proceed to the preliminary washing

of your prints by passing them through 6 changes of clear water, moving them constantly and separating them meanwhile. In a bath prepared as above prints should tone in 5 to 8 minutes. They should be carried only far enough to thoroughly clear the high lights, at which stage you will probably notice that the shadows are a deep red; then pass through a salt bath 2 to 5 minutes, which will arrest toning. After toning, wash well in 3 changes of water, then pass to the fixing bath, separating and moving the prints therein about 20 minutes; after which wash them in 16 changes of water or one hour in running water.

The neutralizing agents, such as bicarbonate of soda, borax, and carbonate of soda, should be mixed separately, and only added in the manner suggested above to the toning solution after the gold has been added.

Temperature of the gold toning bath should be about 60 degrees Fahr. The prints, in order to be thoroughly fixed, should remain in the hyposulphite of soda solution at least 20 minutes, being handled constantly meanwhile. A toning bath prepared as above will be sufficient to tone properly about half a gross 4 x 5 paper. A gallon of fixing solution mixed as described above will be sufficient to fix one gross of 4 x 5 or cabinet size prints.

If by portrait lens you refer to the Eastman portrait attachment, that combination will not work perfectly at a greater distance than 3½ feet from subject, and is not intended for the photographing of landscapes or buildings.—EDITOR.

#### GLYCERINE PROCESS ILLUSTRATED.

In RECREATION of April, 1903, a brief outline was given of the glycerine process of developing platinum prints as perfected by Mr. Joseph T. Keiley, and now generally in use. This sketch was prepared especially for the benefit of those readers of RECREATION interested in photography who, as shown by their correspondence, are ever on the alert to improve and advance. In this issue we reproduce, on pages 344 and 345, a number of imprints made by this process by Mr. Keiley, who permits their use for the benefit of RECREATION photographic readers. These prints have been selected for their strength from the illustrator's point of view, rather than for special artistic merit. An examination of them will show how certain parts of the prints have been strengthened and others subordinated. In this manner strong, effective and harmonious contrasts, such as most readily lend themselves to reproduction, have been obtained. Warmth and texture have also been imparted to the print. Many readers of RECREATION do excellent photographic work and with thought, care and study are entirely cap-

able of producing good material for illustrations. I often receive prints which I should be glad to reproduce, but which would go all to pieces in the reproduction. Many of the prints reproduced appear in the half tone reproduction gray and flat, and are by no means so effective as they might be with a little care on the part of the photographer. I shall, therefore, reproduce in RECREATION, from time to time, certain guide prints as suggestions and some articles from the pen of K. Rowa on "Picture Making with the Aid of the Camera."—EDITOR.

#### LIQUID LENSES.

A new rapid lens has been invented by an Englishman and patented in both the United States and Europe. It is probable that it will be on the market the coming season. While not such a wonderful affair as was first heralded, it is of a sufficiently advanced nature to make its possession desirable, providing the price does not soar too high.

The lens is composed of thin pieces of glass between which is a liquid of practically no dispersive power, but as temperature has much to do with its availability, it must be kept at a temperature between 46 and 72 degrees F. Dr. von Hoegh, of the firm of Goerz, says that a change of temperature of only 2 degrees will cause a decided change in the optical constants, but this extreme sensitiveness to heat and cold is denied by the makers. It covers a field of about 60 degrees, and Dr. Grun, the inventor, says that he can sit in the stalls of a theater and take perfect pictures of the performance with an exposure of 1-100 second.

Thus far the largest instrument made for sale just nicely covers a 4x5 inch plate. With such a lens it will be possible to get bright views of conventions in session; of noted men making evening speeches, where the illumination is only ordinary gas or electric light; and of those social occasions which now can only be preserved photographically by the use of flashlight powder, with its objectionable smoke and dust.—EDITOR.

#### BROMIDE ENLARGEMENTS.

Will some reader of RECREATION please explain the art of enlarging with a common focusing camera? By making a mask for the window, in a room that has but one window, and cutting a square hole out near the bottom of the mask, just the size of the plate or negative to be enlarged, then excluding all other light, placing a negative over the opening, removing the ground glass from the camera and placing the camera back up to the opening, a perfect enlarge-

ment of the negative will be thrown on a white screen placed in front of the camera. Is there a developing paper that will print the negative enlarged if placed on the screen? Will someone explain how this will work and if it can be done what kind of paper to get and where to get it?

J. E. Brackett, Newport, Maine.

#### ANSWER.

Royal bromide enlarging paper will print such a negative. This paper can be procured at any regular photographic dealer's, with instructions for development. It is developed in the ordinary way. Large trays can be procured for the purpose. In making the picture, first get the focus on the screen; then extinguish the light. Fasten the bromide paper, cut to required size, to a strong frame or heavy board surface so as to occupy exactly the position of the white screen on which image was focused.—EDITOR.

#### SIZE OF STOP.

I have a folding camera with Iris diaphragms. What stops should I use on a bright day and on a cloudy day? For interiors, how long should I expose the plate? How can I keep my plates from frilling at the edges? For distant views, should I extend the front of my camera?

I. C. Beers, Gervais, Ore.

#### ANSWER.

If you want sharp pictures with strong contrast, use small stops on a bright day. If the day be cloudy let more light on your plate by using larger stops. Without seeing the interior and knowing the conditions of the light to be used, the character of lens with which the view is to be made and the plate on which it is to be taken, it is not possible to say what exposure should be given. Try a few experiments. Use comparatively little light, a medium stop and a long exposure, and develop with slow developer. Paraffin is sometimes rubbed round the edge of a plate to prevent frilling. If immersed in a solution of formalin a few minutes after fixing, plate will not blister nor frill. In summer the developing bath should be kept cool. You will find it more necessary to extend the front of your camera for near than for distant views.—EDITOR.

#### A UNIVERSAL DEVELOPER.

I occasionally see complaints from amateurs in whose hands velox paper blisters. I have made hundreds of prints on velox and have never had but one case of blistering. That was caused, I am sure, by wet or damp fingers coming in contact with the sensitive surface of the paper before development.

It is surprising how many otherwise well

informed people refuse to believe that a perfect and beautiful photograph can be made from a film negative.

For a long time I used no other developer than eiko-hydro. Bought in properly proportioned powers and diluted with anywhere near the right quantity of water, it will turn out a satisfactory negative from any plate or negative not grossly misexposed. Having read so much about pyro, I procured a package of pyro powders. Following the directions carefully, I developed a roll of films exposed on snow scenes that cost me considerable trouble to obtain. The result was a batch of good negatives badly stained. The stains were irregular in shape and size, appearing like thin spots, printing several shades darker than the rest of the negative.

I have made more poor negatives through misjudging the quantity and quality of the light than from any other cause.

W. B. More, Harrison, Colo.

#### MUCH DEPENDS ON THE MAN.

I want to enter your photo contest, and wish you would give me a few points on cameras. I have a tele photo Poco, D, 4 x 5. Do you think this is better than the Cartridge Kodak, No. 4? Please tell me what you think is a good all around plate camera. What magazine will give me most points on photo taking and finishing?

V. V., Schenectady, N. Y.

#### ANSWER.

Fair work can be done with any good camera, the results being largely dependent on the ability of the man behind the lens. Both cameras mentioned are capable of good results. Any good camera box, fitted with a good lens, will serve your purposes. The Goerz lenses are excellent.

I know of no magazine that could give you more valuable information, of the kind you seek, than RECREATION. Its photo department is conducted purely for the benefit of amateurs.—EDITOR.

#### SNAP SHOTS.

I wish to make flashlight pictures of the interior of a large cave. One portion that I particularly want is 100 feet wide and 200 feet long, or, rather, deep. How much magnesium powder will be required to properly light it?

O. Denny, Martinsburg, Ind.

#### ANSWER.

The question is rather a difficult one to answer. Exposures of this kind require considerable experimenting. I suggest, however, that a number of flashes be made at different points as far forward as possible, employing any ledges that may exist to protect the camera from the direct light of the flash. Each charge might be one ounce or a little over. Reflectors back

of the flash lamp would increase the volume of light.—EDITOR.

I have had considerable experience in taking live game pictures. I use a No. 4 4 x 5 Kodak, and get best results from plates, though films are much easier to carry. When the sun shines I use No. 8 stop and seldom fail to get a good negative. I use a small stop on a cloudy day, and expose 3 to 5 seconds. I get the best results from films by cutting them and developing singly. I have made several attempts to take a time exposure of a live animal on a cloudy day by holding the camera in my hands, but never got a good picture that way.

S. T., Fredericton, N. B.

Of course not. No one can hold a camera still enough and for a sufficient time to get a good picture of that kind.—EDITOR.

At what temperature should water be for washing prints? Can you give me a recipe for a glue like that on the back of postage stamps and labels for mounting squeegeed prints on wet cardboards? How can it be applied to the prints while yet on the ferrotype plate?

Arthur Roth, Prairie du Chien, Wis.

#### ANSWER.

In washing prints water should be at normal temperature. I have not the government formulæ for stamp glue. I do not advise you to apply paste to prints which are drying on ferrotype plates.—EDITOR.

I am anxious to know just how many of RECREATION'S readers own and use cameras, and how many of them do their own developing and printing. I will, therefore, esteem it a personal favor if each of my readers who has a camera will send me a postal card stating this fact, and further stating whether or not he does his own developing and printing.—EDITOR.

The picture on page 346, a clever piece of composite photography, was made for the Des Moines Insurance Co. Mr. S. C. Spear, of Algona, Iowa, who sent it in, says that figures from 7 different negatives were mounted on a large card and rephotographed.

I think J. E. Bates will find his troubles from blisters will disappear if he will make sure his hypo bath is acid. Also try adding formalin to developer. I have used Cyko paper the past year and I find blisters do not form if the hypo is acid.

Dr. A. M. Kenney, Roxbury, Mass.

A young married man whose family was recently enlarged by twins rushed into the telegraph office and wired the glad news to his parents thus: "Twins today, more tomorrow."—Exchange.

DO NOT FAIL TO SEND IN YOUR PRINTS FOR THE PHOTO CONTEST, WHICH WILL END NOVEMBER 30th.



## The Pack and the Picture— A Very Simple Matter.

Amateur photographers have received the new PREMO Film Pack with almost extravagant praises. It meets the conditions of the outdoor picture maker as nothing else has ever done. Whether you use a PREMO Plate Camera or a PREMO Film Camera, it opens the easy way to photography;—a working outfit that is unequalled for simplicity and convenience.

# The PREMO Film Pack

## DAYLIGHT LOADING.

As flat as a handkerchief in your pocket when not in use, as easy to load in daylight as shutting a book; it is unequalled for effectiveness. Carrying twelve non-curling, orthochromatic films; successive exposures are made by pulling out the numbered black paper tabs. The last tab seals the package light tight. Adapted to  $3\frac{1}{4} \times 4\frac{1}{4}$  and  $4 \times 5$  Cameras, the PREMO Film Pack meets successfully every photographic condition. See it at your dealer's or write for particulars contained in the *Premo Year Book*, free.

**ROCHESTER OPTICAL CO., Dept. 209, Rochester, N. Y.**



**Velox**

**The paper that made photographic printing a delight to the amateur.**

One of the latest Velox products is the "Double Weight Rough" which, when printed with white margins requires neither mat nor mount. Unique, artistic. The beauties of platinum paper without the difficulties.

*All dealers.*

**NEPERA DIVISION,**  
Eastman Kodak Co.  
**ROCHESTER, N. Y.**  
Formerly Nepera Park, N. Y.

**DON'T FORGET**  
**Recreation's**  
**Photo Contest**

**T**HIS is the time of year to secure photos of **Live Wild Birds and Game, of Camping Scenes or Other Outdoor Sports.** One such picture may win for you a valuable

**CAMERA,**  
**LENS. TENT,**  
**FISHING ROD,**  
**FIELD GLASS**

or other prize.

See announcement of contest in **RECREATION**, department of Amateur Photography.

**PRINTING VELOX.**

Velox should be properly exposed. Under exposing and forcing development never yields a satisfactory print, producing brown stains in most cases.

After mixing the developer, allow it to stand a few hours before using; also use care in regulating it by introducing potassium.

To produce rich, fine grained blacks, mix hypo about 30 strong, hydrometer test, and to 8 ounces of solution add 15 minims stronger ammonia water. This addition of ammonia seems to be the only medium that will produce fine, soft, deep blacks. After the print is developed, rinse thoroughly and place in the above fixing bath. Never develop a print full and strong. It will always fix out stronger than it looks after the development is apparently completed.

Always thoroughly rinse the paper immediately after exposure; also after development.

Satisfactory sepia tones on velox are obtained by treating a print in the ordinary way, except slightly overprinting it, then develop and fix as usual, and any time thereafter put through the following sepia toning bath:

Soda hyposulphite.....	10 ounces
Ground alum.....	2 ounces
Boiling water.....	50 ounces

Dissolve the hypo in water first, then add the alum slowly. When all is dissolved the solution should be milk white. In this bath prints will tone in 15 to 20 minutes, but will bleach out somewhat, so be careful to print deeper than usual. After toning wash as usual and remove any sulphur remaining on surface of print by sponging it on front and back.

Black prints may be converted into brown or red ones by short or long immersion in the following uranium bath. The black changes to brown, gradually getting warmer in tint until it becomes a decided red.

Water .....	20 ounces
Ferricyanide potassium.....	20 grains
Uranium nitrate.....	20 grains
Acetic acid (glacial).....	1 ounce

Rich blue tones, suitable for marine views, are obtained by combining a bath as follows and immersing the finished print in it until the desired effect is produced:

10 per cent solution ammonia-citrate of iron.....	2 drams
10 per cent solution potassium ferri- cyanide.....	2 drams
10 per cent solution nitric acid....	4 drams
Water .....	40 drams

After toning wash until whites have cleared well. This bath is poisonous, and care should be taken not to use it if fingers are cut or scratched.—W. E. Bertling, in *Western Camera Notes*.



"I made no mistake in selecting a Century Camera. I find it just as represented."

"I am a firm believer in all things 'Century.' Candidly, I never owned a camera which satisfied me until the Century was put on the market, and I have used all kinds, in many sizes and styles."

"In your Catalogue I notice you mention very often 'Century Quality.' I would like to state that I have found the excellent qualities of the Century Camera to be all you claim."

I have two cameras besides the Century, BUT I WOULD NOT EXCHANGE MY CENTURY for a dozen like the other two, and either one cost as much as the Century."

**What's in a Name? EVERYTHING—when referring to Cameras.**

## "Centurys"

are the recognized standard Cameras of to-day. Their superiority has won for them the highest praise from connoisseurs everywhere. Compare them with other cameras in design, finish, adjustments, optical and mechanical features. We court comparison, as it makes the favorable comments regarding "Century Quality" still more numerous and emphatic. Our new Catalogue can be obtained from your dealer or direct by mail.

**Century Camera Co.,**

**Rochester, N. Y.**

OBJECTS WELL CENTERED AND CORRECTLY FOCUSED

# The Focusing Weno



## Hawk-Eye

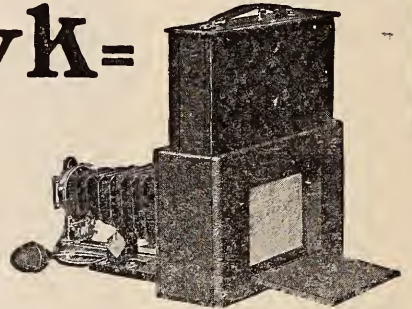

has the advantage  
over all cameras

of a ground glass the size of picture, which works automatically and allows focusing when using film. The result is obvious—perfection of work—satisfaction to the user.

**No. 3 Focusing Weno Hawk-Eye, with B. & L. Automatic Shutter, and Extra Rapid Rectilinear Lens. Pictures  $3\frac{3}{4} \times 4\frac{1}{4}$ , - - - \$27.50**

**No. 4 Focusing Weno Hawk-Eye, same equipment. Pictures  $4 \times 5$ , 30.00**

Hawk-Eye Film can be developed in the Kodak Developing Machine.

*Write for Hawk-Eye Booklet.*

**BLAIR CAMERA CO., Rochester, N. Y.**

## WANT A REEL?

You can get one for nothing.  
Or at least for a few hours' work.

Send me

15 Yearly Subscriptions

to

# RECREATION

and I will send you

## A TALBOT REEL

Listed at \$20

Made by W. H. Talbot, Nevada, Mo.

This is one of the finest pieces of fishing tackle ever made. It is built like a gold watch. Equal to any Kentucky reel you ever saw.

**In Tournaments, Always a Victor  
Among the Angler's Treasures, Always the Chief**

I have but a few of these reels in stock and this offer will be withdrawn as soon as the present supply is exhausted.

Sample copies of RECREATION for use in canvassing furnished on application,

## LIGHT-PROOF BOTTLES.

To exclude light from bottles, dissolve common shellac in alcohol to the consistency of a thick varnish; also alcohol and lampblack, drop black, or frescoer's black to the same consistency.

For coating bottles mix of No. one 2 parts and No. 2 one part. Coat the bottle with this preparation with a varnish brush. After drying, which takes but a few minutes, another coat may be given if necessary.

Bottles coated with this preparation may be washed of any chemicals splashed on them or running down from the neck in pouring, and are hard to scratch. Coat also the part of the stoppers above the necks of the bottles. To those valuing cleanliness on the outside of the bottles this method will at once appeal. For plate backing, take No. 1 one part and No. 2 3 parts. Apply with brush; the coating dries quickly.

HAVE YOU A FRIEND  
ANYWHERE IN THE WOODS,  
IN THE MOUNTAINS  
OR ON THE FARM,

WHO LONGS FOR SOMETHING TO READ  
IN THE LONG WINTER EVENINGS, OR IN  
THE LONG SUMMER DAYS?

SEND HIM RECREATION.

IT WILL PLEASE HIM A WHOLE YEAR  
AND HE WILL RISE UP AND CALL YOU  
BLESSED.

AND IT ONLY COSTS YOU \$1.



# It's Not a Toss-Up



*as to the quality of pictures made with a*

## KORONA Camera



GUNDLACH-MANHATTAN OPTICAL CO., 730 So. Clinton Ave., Rochester, N. Y.

## “THE KORONA and the FILM PACK”

is the title of an artistic  
little folder which tells how  
the **KORONA** can be  
c o n v e r t e d   i n t o   a

### Focusing Film Camera

by the use of the

## FILM PACK ADAPTER

Do you want it? Your name, please.

Mention RECREATION.

## A GOOD FAST LENS

is the principal factor in **High Speed Photography**. There are **poor**, fast (?) lenses and **One Good Fast Lens**. So be sure you get **A GOERZ**.



Series III F. 6<sup>s</sup>. Series I<sup>b</sup> F. 4<sup>5</sup> to 5<sup>5</sup>.

**C. P. GOERZ, Room 27, 52 East Union Square, New York.**

### OIL PORTRAITS ON APPROVAL.

If you will send me a photo of yourself or a friend and state color of hair, eyes and complexion I will paint and send you on approval a miniature oil or pastel portrait.

Canvas 6x8 or 8x10 inches, \$10.00

Canvas 10x12 or 12x14 inches, \$15.00

**Z. EMMONS, 58 West 104th St., New York.**

Reference: Mr. G. O. Shields.

### LANTERN SLIDES COLORED SKILLFULLY AND ARTISTICALLY FOR Lecturers, Teachers and others

I refer by permission to the Editor of RECREATION

**MRS. C. B. SMITH**  
**606 W. 115th Street, New York City**

To remove matt varnish, moisten a rag or piece of cotton wool with methylated spirit and rub the film side. This will remove the varnish easily without affecting the negative.—Exchange.

DO YOU WISH TO IMPROVE YOUR SHOOTING? IF IT IS AS GOOD AS IT CAN BE, DO YOU WISH TO KEEP IT SO? IN EITHER CASE, THE J. C. HAND TRAP WILL BRING WITHIN YOUR REACH THE FULL ADVANTAGE OF A SHOOTING RANGE. THESE TRAPS WILL SUCCESSFULLY THROW ANY OF THE CLAY TARGETS NOW IN USE, GIVING A LIFE LIKE REPRESENTATION OF A BIRD IN FLIGHT. I WILL SEND YOU A J. C. HAND TRAP FOR 5 YEARLY SUBSCRIPTIONS TO RECREATION. SEND IN YOUR CLUB NOW, AND IMPROVE ON YOUR SHOOTING.

## INVISIBILITY OF THE OBVIOUS.

It is strange that an operator is often oblivious of the most obtrusive objects on the focusing screen of the camera while intent on getting accuracy of detail. His attention is riveted on the portion of view where the focus is set, while he is totally blind to subjects which fairly thrust themselves before his vision; and he is only conscious of their presence when he develops the plate, and they loom before his astonished eyes. Especially is this the case with objects in the immediate foreground. His vision is charmed with the general effect of a landscape, while he does not see the ugly branch of a tree in the foreground; ugly, because it is out of harmony, exaggerated and out of focus, covering, perhaps, the vision which delighted his eyes. Thus a fine picture is spoiled, because intensity of interest in the beauty alone prevented him from perceiving the disturbing element in the composition.

Sometimes the finished negative reveals the fact that the operator has failed to notice the conjunction of some distant object with one near. A bush or tree, or even a rail fence or post, appears on the plane surface of the photograph as if it were an essential part of the figure in the foreground, often as if it were part of the headgear of a lovely maiden, rendering the picture ridiculous.

The remedy for such mishaps is apparent. Cultivate care and close observation of all the parts of a scene and see that the relations of things are properly secured.—The Camera.

## A SUGGESTION FOR CHRISTMAS.

Have you commenced to think of Christmas presents? If so, here is a suggestion.

A yearly subscription to RECREATION furnishes one of the most delightful, instructive, entertaining Christmas presents you can possibly give a man or boy who is interested in nature, in fishing, shooting, amateur photography; or, who is fond of the woods, the fields, the mountains, the lakes or the rivers.

Many of the presents which people give their friends afford pleasure only for a few days, or weeks. A subscription to RECREATION means solid comfort a whole year. It reminds your friend 12 times during the year of your kindness and generosity. There are many men and women who for 5 years past have annually sent in long lists of names of friends, accompanied with a check in order that these friends might be made happy a whole year. Would it not be well for you to adopt this plan?

Try it and see how grateful the recipient will be.

IN ANSWERING ADS PLEASE MENTION RECREATION.



# ANSCO and CYKO

ARE PRIME FACTORS  
IN THE PRODUCTION OF

## PERFECT PICTURES

No other similar products  
have so great a latitude in  
exposure and development

The new daylight loading film  
**ANSCO**, fits all standard makes of film  
cameras.

**CYKO**, the paper that prints by any  
light. Seven different grades.  
No dark room required.

**Cyko Manual and AnSCO Booklet**  
sent on Request

ASK YOUR DEALER OR  
**THE ANTHONY and**  
**SCOVILL CO.**

122-124 Fifth Ave., N. Y.  
Atlas Block, Chicago



# When using

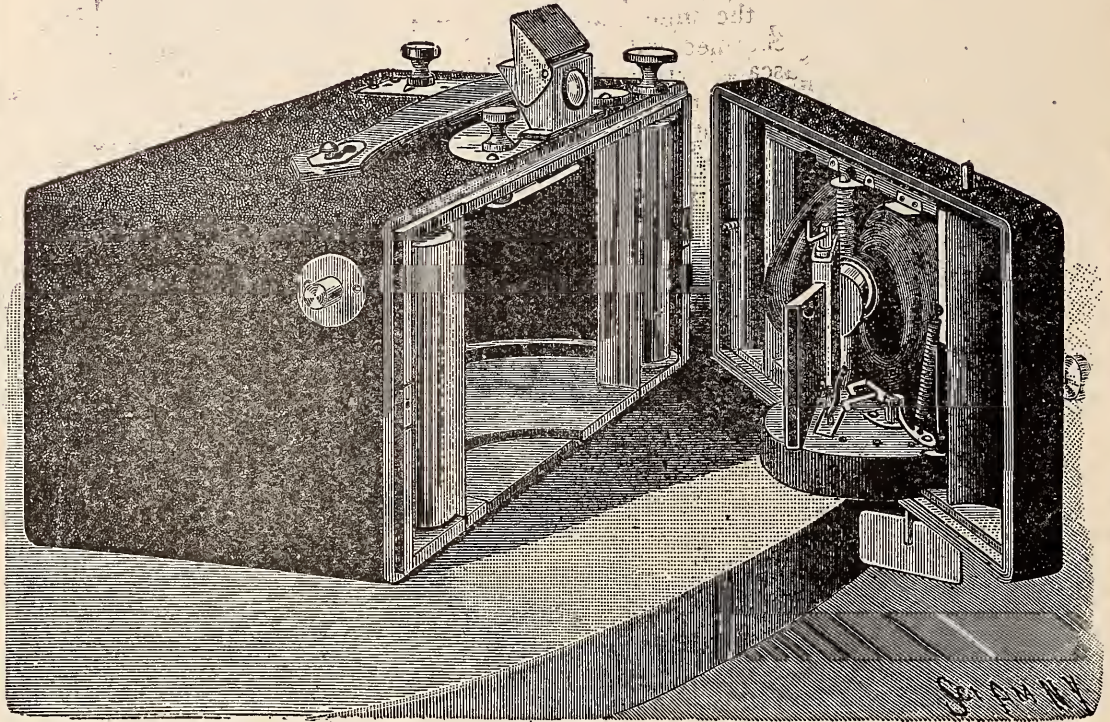

Front of camera removed, showing flat opening in the tube attached to the back of the lens, and through which, as the lens revolves from side to side, the exposure sweeps over the film.

an ordinary limited-view camera, how many times you want to get in your picture just a little more than your camera will get on the plate. It may be an object that will make the view more artistic, or perhaps is something that is really necessary to make the picture complete, but, *you want it!* If you place your camera farther back, you then reduce the size of the objects in your picture, besides the difference in the point of view *changes the whole picture*. If you use a wide-angle lens you will get more in your picture, but the whole picture is changed by the violent perspective of the wide-angle of the lens. *You haven't got what you want!*

If you get a larger camera, you merely get the same scene larger in size but no larger in *scope*, besides, you have the expense of larger camera, larger plates, and extra weight to lug around.

There **is** a camera which will not only take the ordinary size of picture, but if you want to get more view on the *sides* (not more *blank sky* and *out-of-focus foreground*), you can make the photograph (the original one being 5 x 4) either 5 x 6, or 5 x 8, 5 x 10, or 5 x 12, and this camera *the only one* which will do it, is the

# AL-VISTA PANORAMIC CAMERA

Our  
Superb  
Catalogue  
Free  
on  
request

Mention  
RECREATION



THIS IS A SCENE FROM LINCOLN PARK, CHICAGO, SHOWING THE 180° THE "AL-VISTA" TAKES IN ONE SWEEP.

The swing-  
ing and re-  
volving lens  
does it—you press  
the button, and in  
an instant it records  
everything within its sweep  
of nearly 180 degrees—**half  
a circle!** If you owned a regu-  
lar 10 x 12 camera, think of what  
you could save if, instead of using a  
full 10 x 12 plate every time, you could  
use only just so much of a plate as you had  
need of for each individual picture, and could  
use the remainder for other views! That is just  
what you can do with an "Al-Vista."

Suppose you had a Model "5-B," which takes pictures 5 inches wide, by from 4 up to 12 inches long; the exposures on your roll of film *might* be first, 5 x 4, then 5 x 12, then 5 x 8, then 5 x 4, and so on, depending upon just the length of each view you happened to *want* to take.

How often you find yourself on some high place, with a view just in front of you that would not be at all interesting as an ordinary camera would take it, but the *whole sweep of which view* would make a delightful picture; and you long for a camera which *will* record the whole view. Prevent these chances of disappointment, these chances of taking views which none of your friends will have anything to equal, by getting an "Al-Vista" Panoramic Camera.

---

**THE MULTISCOPE & FILM CO.**  
136 Jefferson Street, Burlington, Wis.

# Decorate Your Den

With a set of the most beautiful  
**Hunting and Fishing Pictures**  
 ever made.

---



---

**15 PLATES.            SIZE FOR FRAMING, 18 x 24 INCHES**

---



---

**SUBJECTS :**

**ELK HUNTING      SALMON FISHING      MOOSE HUNTING      TROUT FISHING**  
**HY. SANDHAM**

**MALLARD SHOOTING—BLACK BASS FISHING—C. E. DENTON**

**TARPON FISHING—BLUE FISHING—FRED S. COZZENS**

**ANTELOPE HUNTING—GOOSE SHOOTING—FRED REMINGTON**

**GROUSE SHOOTING—WILD TURKEY HUNTING—R. F. ZOGBAUM**

**MUSKALONGE FISHING—F. H. TAYLOR**

**DEER HUNTING—A. B. FROST**

**ROCKY MOUNTAIN SHEEP HUNTING—E. KNOBEL**

These 15 plates are lithographed in true colors of nature and altogether make one of the finest series of pictures of out-door sports ever published.

**ORIGINALLY ISSUED AT \$50 A SET**

I have bought the last of them and can furnish a complete set for 15 yearly subscriptions to RECREATION.

**Or will sell at \$10 a Set**

I also have enlargements of the following photographs :

**ROCKY MOUNTAIN GOATS**

Published on pages 90, 91, 92 and 93, of the February, 1903, issue of RECREATION, size 8 x 10, \$5 a set

**WOOD DUCK SHOOTING**

Published on page 95 of the February issue of RECREATION, size 10 x 12, \$1.50 each.

**ROCKY MOUNTAIN GOAT**, male and female, size 10 x 12, price \$1.50.

**ROCKY MOUNTAIN GOAT**, male and female, latter sitting down, size 8 x 10, price \$1.50.

**FISHHAWK**, with Dead Chicken, published in March, 1903, RECREATION, size 10 x 12, price \$1.50.

**BLACK BEAR**, in Montana Pine Forest, size 10 x 12, price \$1.50.

**COON LEAPING FROM TREE**, published in March, 1903, RECREATION, Size 10 x 12, price \$1.50.

---

**Address : RECREATION, 23 West 24th Street, N. Y. City**

**MENDING BROKEN NEGATIVES.**

Broken negatives are sometimes a source of great trouble, since they may be of subjects that can not be replaced. If the glass, only, is broken and the gelatin holds the pieces together, the film is usually tripped from the glass by well known processes; but in some instances, architectural views, for example, it is almost impossible to avoid obvious distortion, and, when the film itself is broken, stripping is no remedy. The best thing in such cases is to break the negative, if it is not already broken, and to clean the broken edges carefully. Then fasten the largest piece to a glass plate with strips of gum paper, and apply to the edges Canada balsam diluted with xylol. Touch the other pieces of the negative at the edges with the balsam, and join them to the larger pieces, so as to fit exactly. In this condition the Canada balsam can be worked without heating. It has about the same index of refraction as the glass, and if the negative is carefully joined, the internal surfaces of the cracks will no longer reflect any light, and the break will almost have disappeared. If any of the balsam gets between the negative and the glass it does no harm, and the parts will adhere so much the better when the xylol evaporates. Clean the surface afterward by rubbing it gently with benzine. When in the print the injured part will hardly be perceptible.—Photography.

**AN IMPORTANT OFFER**

For 2 Yearly Subscriptions to RECREATION

I will send you

**A RIFLE WICK PLUG**

Made by HEMM & WOODWARD, Sidney, Ohio, 30 caliber up to 50 caliber.

OR

**A SHOT GUN WICK PLUG**

20 gauge up to 10 gauge

For 3 Yearly Subscriptions to RECREATION

**A Pair of Shot Gun Wick Plugs**

20 to 10 gauge.

Sample copies for use in canvassing furnished on application.

Address RECREATION, 23W. 24th St., N. Y. City

**EASTMAN'S  
NON-CURLING  
FILM.**

**A new product with marked advantages over all other films.**

Does not curl; is orthochromatic and non-halation; has no electric markings and is superior in speed and latitude. Now ready in all Kodak Cartridge sizes. No increase in price over ordinary film.

All Dealers.

**EASTMAN KODAK CO.  
ROCHESTER, N. Y.**

I have just received the King 11 foot folding canvas boat which you sent me as a premium for 25 subscriptions for RECREATION. I am more than pleased with it. It rides like a cork on the water, is staunch, well proportioned, and complete in all respects, and is just what a sportsman needs. Our club is so pleased with it that if we can sell our wood boats and canoe we shall replace them with King canvas boats.

D. L. Mells, St. Thomas, Ont.

RECREATION sells like hot cakes. It is the only sportsmen's magazine on earth.

J. A. George, Eastlake, Mich.

**For Golf & Tennis Players**

**"PRESTO! - CHANGE!"**

ATTACHABLE EYEGLASS TEMPLES



Eye Glasses into Spectacles. Spectacles into Eye Glasses

**BE PROTECTED!**

**DON'T BREAK OR LOSE YOUR GLASSES IN EXERCISE, WIND AND STORM**

Can be attached by anyone

Send thickness of lens when ordering by mail

Price in Nickel 50c. a pair.

Gilt 75c. a pair.

Gold Filled \$1 a pair.

Solid Gold \$2.50 a pair.

Established 1842 GALL & LEMBKE, Dept. C, 1 W. 42d St.

21 Union Sq., New York

Send for Circular



GLASSES WITHOUT TEMPLES. PATENTED June 17<sup>th</sup> 1902



GLASSES WITH TEMPLES. COVERED BY Foreign Patents.

## HUNTING IN NOVA SCOTIA.

My guide came in one day in January and reported a large moose about 15 miles from town, and we were soon under way. Spending the night at the guide's house we made an early start. There was plenty of snow for tracking, almost too much for tramping, and late in the afternoon my enthusiasm had fallen to zero. No sign of a moose or anything else in the game line had been seen, so we decided to strike for the timber and camp for the night. Turning to our left we crossed a barren when just at our feet we struck the track, not 2 days old, of a large moose, going North. We kept a West course through small hard wood on which moose feed. For an hour we plodded through the snow, taking little heed to steps, our guns on our backs, when just as we topped a small ridge, up jumped a big moose and started up the rise at a smart clip. We struggled to get at our guns, my Winchester catching in my hunting shirt, but a desperate pull cleared it, and throwing it to my shoulder I glanced through the sights for a dead on end shot.

The moose stopped and looked around and my guide fired. I gave the moose another shot as it disappeared. We rushed down the hill and over the crest in time to see the brute floundering on 3 legs; another shot dropped her, and we were soon up with the game, a fallow cow moose, yet black in good condition. My first shot had struck the moose on the hip, passed through the body and lodged in the shoulder.

We were happy as we camped under our lean-to, a rousing fire at our feet. At day-break my guide started to the nearest settlement for help to carry out the meat, and I stayed in camp. Finding the time drag I started to look over the ground. Leaving my gun I walked over the barrens to a strip of burnt timber, when I was startled by a sharp snarl, and saw, not 20 yards from me, a large wildcat tearing a rabbit. I stooped slowly and picked up a limb, but the cat made a short spring at me. As I slashed at him he changed his mind, seized the rabbit and ran up an old pine stump 12 or 15 feet high, and growled and spit at me. This was too much, so taking out my knife I soon cut a stout maple stick and started up the stump, the broken limbs making a good ladder. The cat spit and growled, but held his ground and rabbit. Keeping my head well back I made my way up to striking distance, just in front of the ugly snarling face, and landed a quick, sharp blow between his ears. A yell, a slip, something soft hit me in the face, and a crash. I could feel the cat's teeth in my leg and struck blindly and then scrambled on my feet. The cat was kicking on the other side of the stump. The rabbit had fallen, striking my face, and the cat's teeth were only a sharp twig puncturing my leg. A few blows quieted the cat, and taking him over my shoulder I tracked back, feel-

ing that I had got off easily. At noon my guide returned, and the moose meat was packed out to a meadow road, where a boy with ox and sled took up our loads, and we started for home. The animal weighed over 500 pounds dressed meat.

February 1st word came from Aspotogan that a bear or bears had been located in a den near the mountain. Next morning a 20 mile drive took me to Northwestern cove and a 4 mile tramp took us to the grounds. The greatest caution was observed on our approach to the den. Everything was quiet; no signs of bear could be found. My men were positive that a bear was in the hole, but no one would venture in. If I wanted that bear I should have to get him out myself.

Slipping off my knapsack and cap I cautiously entered the den on all fours. The passage was dry, leading upward and very dark. My nose soon told me that the cave had some occupant. I wriggled on for 30 feet, keeping my rifle pushed ahead and lying flat to allow light to enter. The passage widened to a cave, and as my eyes became accustomed to the dim light I thought I could see a dark mass moving or rocking to and fro. I lay perfectly still. Presently I heard a sniffing, then a decided snort. It was getting creepy. I raised myself on my left arm and cocked my rifle. The rustling and sniffing continued. I had certainly intruded on the winter nap of a first cousin of "Adam Zad——." "Make no truce with the bear," kept dinging in my ears. I was in for it sure. There was more than one, I could tell by the sniffs. I was beginning to get impatient and wanted to know the worst. Suddenly out of the darkest part of the cave gleamed 2 balls of fire. I knew what that meant; then 2 more not so wide apart; then 2 more! Great Scott! had I struck a menagerie?

The snorting and sniffing continued. Bruin was waking up. I raised my rifle, a ray of light lay along the barrel and aiming carefully between the 2 largest balls. I pressed the trigger. The cave was filled with the report and a decided row was going on at the extremity of the cave. I doubled myself around and clawed my way down the passage.

I told my story and we gathered bark and brush and soon had a good smoke at the cave's entrance, and as it grew in density a commotion was heard in the cavern. The fire was raked away from the entrance and presently a small bear made his appearance, blinking in the light, and then another one evidently in a hurry to get out. Two shots rang out and 2 yearling bears lay dead. After the smoke had cleared away I ventured in and ran against the carcass of the first bear. He did not move when I poked him with my rifle so I concluded he was dead. A 4 mile tramp for a rope and the old bear was dragged out, and all 3 then skinned. I had the bounty offered by the district as well as the sport.

E. D. Lordly, Chester, Nova Scotia.



# WHAT IS IT?

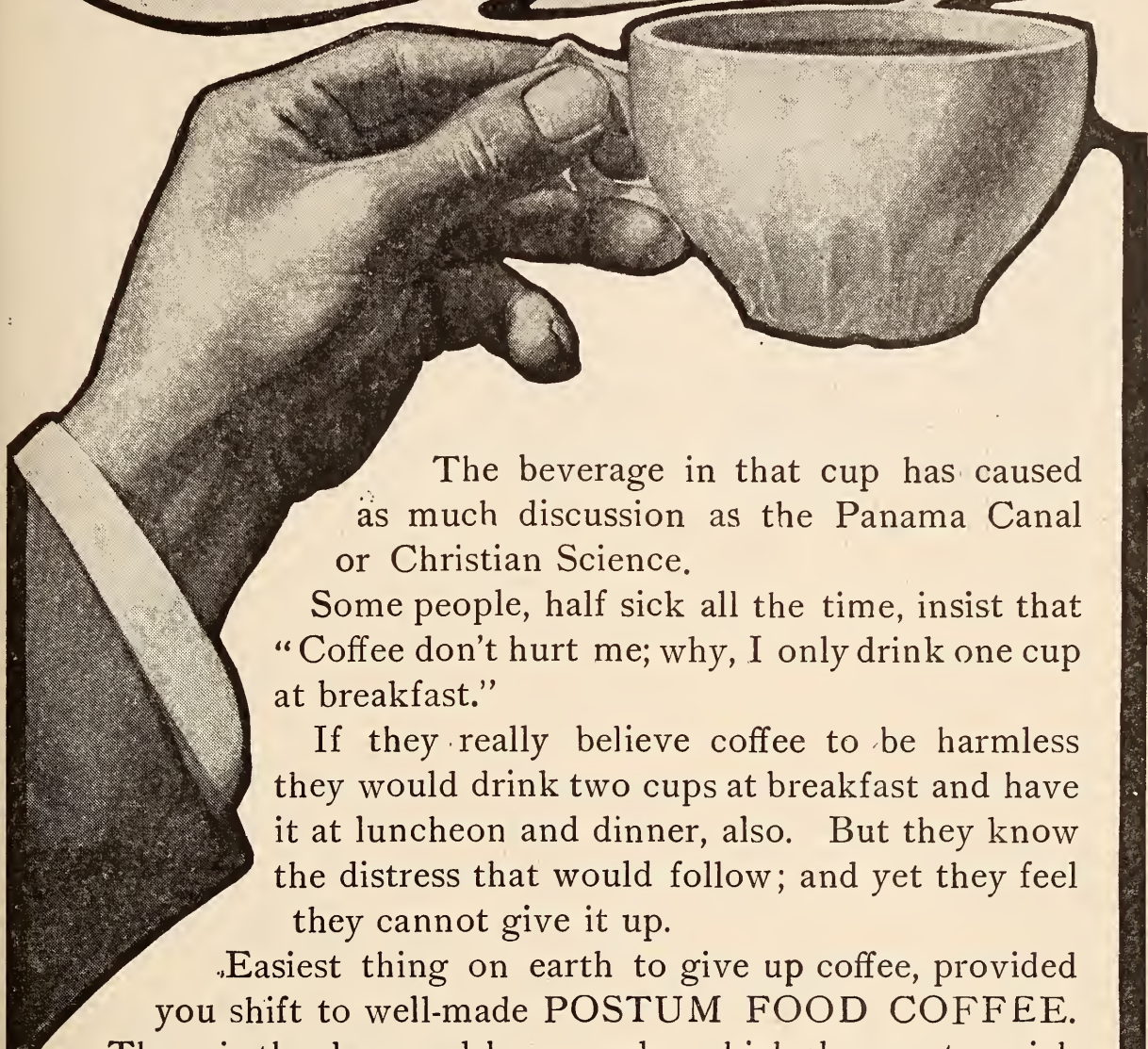

The beverage in that cup has caused as much discussion as the Panama Canal or Christian Science.

Some people, half sick all the time, insist that "Coffee don't hurt me; why, I only drink one cup at breakfast."

If they really believe coffee to be harmless they would drink two cups at breakfast and have it at luncheon and dinner, also. But they know the distress that would follow; and yet they feel they cannot give it up.

Easiest thing on earth to give up coffee, provided you shift to well-made POSTUM FOOD COFFEE.

There is the deep seal-brown color which changes to a rich golden-brown when cream is added. There is the crisp yet delicate flavor of the most expensive grade of Java, and a fragrance, not just that of coffee, but refreshing and inviting, which belongs only to POSTUM.

In a week after the change, the old aches and ails begin to disappear, and the indescribable joy and comfort of returning health sets in.

There's a reason, and you can make it plain to yourself by shifting from the drug-drink to the pure food drink—

## POSTUM

### A MOUNTAIN LION HUNT IN A SNOWSTORM.

Three miles Southward from my home is Summit lake. It lies at the foot of the Black hills, and is a great summer resort for lovers of trout fishing and beautiful scenery. Around it was once a hunter's paradise, and there are yet a good many bears, deer and cats; while often a lion comes down from the hills for a trip around the lake in quest of deer.

In the winter of '89 I had been out in the hills hunting bear trees. Several inches of snow lay on the ground and more was in prospect. I had hunted for a bear tree all day, but failed to find one. My dogs, Don, Sport and Little Boy, were with me. I had turned my steps homeward when, on a log on the side hill, I discovered big lion tracks. They were fresh, and the dogs were going up hill with heads in the air. I followed rapidly to stop them, as I had on several occasions lain out all night, wet and cold, while the dogs chased a lion from tree to tree.

I caught the dogs at the top of the hill and I noted that the lion was heading for what was known as the falls. I had come through that country in the morning and had jumped a small band of deer there. I knew the lion would stop in that neighborhood till he got a deer. As it was getting dark I traveled for home. Snow fell steadily all that night, and the next morning it was a foot deep. However, it was good traveling, for the snow was as light as feathers.

After a hasty breakfast, I took the dogs and struck out. I had 4 dogs that morning, Sport, Don, Little Boy and Nancy. Sport was one of my white fox hounds that had a record of treeing 8 bears in one week. Don was his side partner in treeing anything that wore fur. Nancy was a half breed bird and hound, a great starter, but a poor stayer. Little Boy was a pup 6 months old, but a grittier pup never lived. He was a white, full bred fox hound.

On my way out I was joined by a neighbor's son, E. B. Taylor, and we had gone a mile when the dogs started a cat and treed him in short order. A bullet from Taylor's rifle settled him. We arrived at the neighborhood of the falls and circled the country over for several miles, but failed to strike the lion's trail. We were standing on a log debating the question where he could be, when suddenly a long, deep, mournful bay broke on the still air, and I turned to look for the dogs. Sport was missing. Again that deep, bell-like note. The other dogs rushed down the hillside in a whirlwind of flying snow. I turned to Taylor and said, "We've got him now." Presently old Don's fog-horn chimed in with the yelps of Nancy and the howls of Little Boy. I followed the dogs a mile, when I heard them baying the lion. I ran to them, but the game fled, with Little Boy grabbing at his tail. The lion headed for the big hills North of the lake, and the dogs were

soon out of hearing. I traveled on their trail a mile and a half, losing Taylor from the start.

I had stopped to listen for the dogs, when I heard them coming on the back track, Sport giving tongue like a fire alarm and the others keeping up their end of the noise.

Suddenly the lion came into view. He was a big fellow, his tail erect and swollen like an angry house cat's. He was far away, but coming straight to me on his back trail. He would make 2 or 3 big leaps, stop to listen to the dogs, then trot along again. It was the sight of a lifetime to see him leaping over the logs and small brush. He came straight toward me, till within 15 yards, then jumped on a log and snuffed the air in my direction. He still carried his banner up, but the end of it was twisting like an angry snake.

Holding for his shoulder I cut loose. He made a tremendous spring 20 feet into a fir thicket. I ran to where he had jumped to give him a finishing shot before the dogs could get there; otherwise there would be trouble. I took his trail as fast as I could travel, but Sport passed me, yelling with rage, and plunged into a thicket. There were a few squeals and grunts, and, running in, I found Sport and the lion having a great scrap. Before I could shoot, Little Boy and Don took a hand. The lion saw me and tried to get away. He jumped, and cleared himself of all but Little Boy. That pup just shut his eyes and held on. I gave the lion a shot in the head and he gave up the ghost.

Thus ended one of the grandest chases after a lion that I ever took part in. At times it looked as if he would escape both dogs and guns. He treed 4 times in the 5 hour chase, but would jump as the dogs came up. Taylor arriving, we dressed the victim. We estimated his weight at 160 pounds. His length was 7 feet 9 inches from tip to tip.

Two of the dogs in this chase met death afterward in strange forms. Sport broke his neck in the kennel by jumping from a platform. Little Boy was killed by a bear's falling on him from a tree and crushing him. The bear was shot dead and fell squarely on the dog. If there is a Happy Land for good dogs Sport and Little Boy are there.

Frank Mossman, Kamilche, Wash.

---

Already many thousands of people are wondering what they are going to get for Christmas presents. Other thousands are wondering what they are going to give their friends. If you wish to make a present to a man or boy who is interested in shooting, fishing, amateur photography, or nature study, give him a year's subscription to RECREATION. Nothing you can possibly buy for \$1 would give him so much pleasure as 12 issues of this magazine. Come early and avoid the rush.



ANY of these beautiful, genuine Diamonds and fine Pearls, in solid gold, hand-made mountings will be sent direct from our factory on receipt of price, or C. O. D., subject to inspection. Order by number. We send goods prepaid and guarantee safe delivery. Your money back without a question if you are not wholly pleased. Our Diamonds are of superior quality and we sell only fine, high-grade goods and list everything at wholesale prices. Our beautifully illustrated Catalogue shows thousands of photographs of the newest and finest goods. IT'S FREE—send for it to-day and save one-half on your Christmas shopping. We are the largest concern in the business and one of the oldest, —Est. 1840. We refer to the Commercial National Bank of Chicago. Capital two million dollars.

**S. T. ALTEMUS & CO.,**

Diamonds, Watches, Jewelry, Sterling Silver,  
Cut Glass, Novelties, Etc., Etc.

148-M Stewart Building,  
Chicago, Ill. U. S. A.

My premium, the Marble pocket axe, was received Christmas day to swell my list of presents, for I regard it as nothing less than a present. I do not see how you can afford to give such fine premiums for so few subscriptions.

H. V. S. Hubbard, Los Angeles, Cal.

The Korona camera you sent me arrived O. K. and is much superior to what I expected for so little work.

A. D. Huether, Warton, Ont.

Free:—I will give anybody sending me a subscription or renewal, any one of the articles named below:

Ideal Shell Closer, 10-12-16 gauge, sells for 50c.

Ideal Shell Loader, 10-12-16 gauge, sells for 50c.

Perfection Gun Oiler, can not spill when not in use, worth 50c.

Web Shot Shell Belt, 10-12-16 gauge, sells for 75c.

Henry B. Floyd, 723 Eighth St., N. W., Washington, D. C.

No. 58

HERE IS A KNIFE Men Love So Much They Hate to Throw an Old Handle Away

It Was Teddy's Camp Knife!

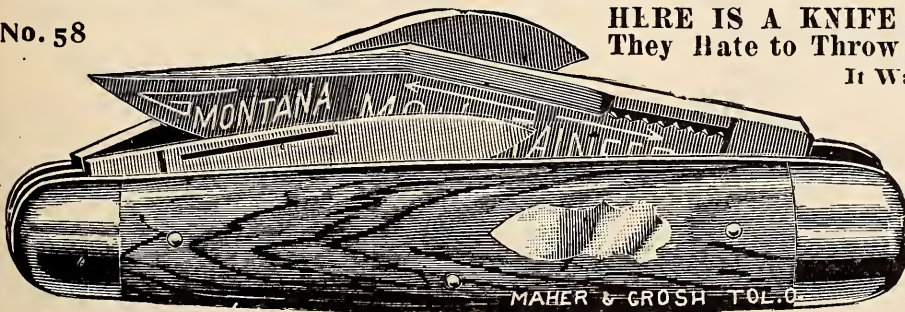

No. 58. Cut is exact size; ebony handle, 3 blades, German Silver ends. The long blade is for rough or fine work; the medium blade is as thin as a razor. Price, postpaid, \$1.60 for \$5.

The lower cut is "Chauncey Depew's pet," has three blades (one is a file). Handle is choicest selected pearl; German silver back and ends. Price in chamois case, \$1.50 postpaid. Same knife, 2 blade, \$1; plainer finish, 3 blade, same quality, \$1; smaller 2 blade, for lady, 75 cents.

Illustrated 80-page List free, and "How to Use a Razor."

**Maher & Grosh Co.,**  
74 A STREET, TOLEDO, O.



**H. J. TILLOTSON, M. D.**  
 The Master Specialist of Chicago, who Cures Varicocele,  
 Hydrocele, and treats patients personally.  
 Established 1880.  
 (COPYRIGHTED)

# Varicocele Hydrocele

**Cured to Stay Cured in 5 Days.  
 No Cutting or Pain. Guaranteed  
 Cure or Money Refunded.**

**VARICOCELE.** Under my treatment this insidious disease rapidly disappears. Pain ceases almost instantly. The stagnant blood is driven from the dilated veins and all soreness and swelling subsides. Every indication of Varicocele vanishes and in its stead comes the pleasure of perfect health. Many ailments are reflex, originating from other diseases. For instance, innumerable blood and nervous diseases result from poisonous taints in the system. Varicocele and Hydrocele, if neglected will undermine physical strength, depress the mental faculties, derange the nervous system, and ultimately produce complicated results. In treating diseases of men I always cure the effect as well as the cause. I desire that every person afflicted with these or allied diseases write me so I can explain my method of cure, which is safe and permanent. My consultation will cost you nothing, and my charges for a perfect cure will be reasonable and not more than you will be willing to pay for the benefits conferred.

**Certainty of Cure** is what you want. I give a legal guaranty to cure or refund your money. What I have done for others I can do for you. I can cure you at home

**Correspondence Confidential.** One personal visit at my office is preferred, but if it is impossible for you to call, write me your condition fully, and you will receive in plain envelope a scientific and honest opinion of your case, Free of charge. **My home treatment is successful.** My books and lectures mailed free upon application.

**H. J. TILLOTSON, M. D., 140 Tillotson Bldg, 84 Dearborn St., CHICAGO**

**Something Special — Playing Cards Free:**—To each person sending me \$1 for one year's subscription to RECREATION, or sending it direct to be placed to my credit, I will forward, all charges prepaid, a pack of elegant gold edge playing cards. These are no cheap second quality cards but first quality, of extra selected stock, highly enameled and polished, fancy set pattern backs, each pack wrapped in handsome glazed wrapper and packed in strong telescope case.

L. J. Tooley,  
 428 Portage St., Kalamazoo, Mich.



## Reduce Your Fat

But don't ruin your stomach with a lot of useless drugs and patent medicines. Send to Prof. F. J. Kellogg, 1020 Kellogg Bldg., Battle Creek, Mich., for a free trial package of a treatment that will reduce your weight to normal without diet or drugs. The treatment is perfectly safe, natural and scientific. It takes off the big stomach, gives the heart freedom, enables the lungs to expand naturally, and you will feel a hundred times better the first day you try this wonderful home treatment.

I have only recently had an opportunity to give the Talbot reel you sent me a thorough trial, and I must report most favorably in its behalf. I have made many long casts with it, landing some heavy fish. The reel showed no inclination to overrun. Its smooth gear, general finish and material warrants its position in the front rank of reel construction.

H. B. Ogden, New Orleans, La.

Looking through some old magazines I happened to come across RECREATION, which I had never seen before. I did not leave a page unread and found it so interesting that I send herewith \$1 for a year's subscription.

W. Halgren, Wellesley, Mass.

I acknowledge with many thanks receipt of the handsome flag sent me for my cottage. It will fly next summer in honor of the best magazine on earth.

G. W. Marvin, Adrian, Mich.

## FREE BOOK, WEAK MEN



My illustrated nature book on losses varicocele, impotency, lame back, free sealed, by mail. Much valuable advice and describes the new DR. SANDEN HERCULEX ELECTRIC BELT. Worn nights. No drugs. Currents soothing. Used by women also for rheumatic pains, etc 5,000 cures 1902 Established 30 years. Advice free.

**DR. G. B. SANDEN,**  
 1155 Broadway, N Y.

# A KNIT JACKET

A handy and comfortable garment to wear when shooting

**At the trap  
In the field, or  
In the woods.**

For 3 yearly subscriptions to RECREATION I will send you a **Hand Knit Jacket**, made by Geo. F. Webber, Detroit, Mich., and listed at \$4. You can get the 3 subscriptions in 20 minutes.

**Sample copies of RECREATION sent on request.**

With rodinal and metol, the image comes out quickly, but is a long time in gaining density. With glycin and éikonogen, the image takes longer to appear, but grows more quickly. With ortol and pyro, the image appears in about a minute, and grows steadily. With hydroquinone, the image is longer in appearing, but when it starts, the density is put on quickly. Metol and hydroquinone combined act well together, and give a good steadily working developer.—Exchange.

Wool—I give that song peddler 10 cents every time I meet him.

Van Pelt—But he sells only the words of the popular songs, not the music.

Wool—That's why I feel like encouraging him.—Exchange.



**MENNEN'S BORATED TALCUM TOILET POWDER**

TRADE MARK

**A Positive Relief For PRICKLY HEAT, CHAFING, and SUNBURN, AND ALL AFFLICTIONS OF THE SKIN.**

"A little higher in price, perhaps, than worthless substitutes, but a reason for it." Removes all odor of perspiration. Delightful after Shaving. Sold everywhere, or mailed on receipt of 25c. Get Mennen's (the original). *Sample Free.*

GERHARD MENNEN CO., Newark, N. J.

## One Night Dispels COLDS and "GRIP"

with all debilitating after effects  
—IF YOU USE

# ORANGEINE

(Powders)

Under simple directions in every package.

**NOTE.—Do not neglect colds and upsets, which often cause all-winter weakness. The many who know Orangeine say:**  
**"I have not had a cold or headache in years, which Orangeine did not quickly drive away."**

*The timely use of Orangeine promptly corrects Headache, Fatigue, Neuralgia, Stomach Upsets, which often lead to serious sickness; insures good health, good spirits, and greatest possible productivity of life's time and energy.*

**TRIAL PACKAGE FREE.**—Orangeine is sold by druggists everywhere in 25c., 50c., and \$1.00 packages. On receipt of request we will mail 10c trial package FREE with full directions, composition and description of its wide human influences. Address "Orangeine," Chicago, Ill.

The following formula gives a stainless pyrogallic acid developer:

- A.—Sodium sulphite (crystal), 160 grams.  
Pyrogallol, 25 grams.  
Water to, 1,000 cubic centimeters.
- B.—Caustic soda, 11.5 grams.  
Or caustic potash, 8 grams.  
Water to, 1,000 cubic centimeters.

For use mix one part A, one part B, and one part water.—Exchange.

The Marble hunting ax is the best thing in that line I ever owned. It can't be beaten.

Felix Alston, Irma, Wyo.



**ARNICA Tooth Soap**  
*the International Dentifrice*

Beautifies the teeth, hardens the gums, sweetens the breath. Preserves as well as beautifies the teeth. Comes in neat, handy metal boxes. No powder to scatter, no liquid to spill or to stain garments.

25 Cents  
At all Druggists.

C. H. STRONG & CO., Proprietors,  
Chicago, U. S. A.

## SOME RARE OPPORTUNITIES

These goods are all new, and will be shipped direct from factory. Prices named are those at which manufacturers and dealers usually sell. Here is a good chance to get

A Book, a Gun, a Camera  
A Sleeping Bag, a Fishing Rod  
A Reel, a Tent, } FREE OF COST

Subscriptions need not all be sent at once. They may be sent in installments as taken and credit will be given on account. When the required number is obtained the premium earned will be shipped.

### TO ANY PERSON SENDING ME

TWO new yearly subscriptions to RECREATION at \$1 each, I will send a copy of *Hunting in the Great West*, cloth; or a Zar Camera, listed at \$1; or an Ingersoll Watch or Cyclometer, listed at \$1; or a Recreation Waterproof Match Box, made by W. L. Marble and listed at \$1; or a Shakespeare Revolution Bait listed at 75. cents; or a Laughlin Fountain Pen; or a dozen Trout Flies, assorted, listed at \$1; or a pair of Attachable Eyeglass Temples, gold-plated, made by Gall & Lembke; or one Rifle Wick Plug, made by Hemm & Woodward, Sidney, Ohio, 30 caliber to 50 caliber, or Shotgun Wick Plug, 20 gauge up to 10 gauge, or a pair of chrome tanned horsehide hunting and driving gloves, listed at \$1.50, made by J. P. Luther Glove Co.

THREE new subscriptions at \$1 each, a safety pocket ax, made by W. L. Marble and listed at \$2.50; or a dozen Bass Flies, assorted, listed at \$2; or a pair of Shotgun Wick Plugs made by Hemm & Woodward, Sidney, Ohio, 20 gauge to 10 gauge; or a Polished Buffalo Horn Gun Rack, made by E. W. Stiles; or a pair of gauntlets, for hunting and driving, ladies' size, listed at \$2.50, made by J. P. Luther Glove Co.,

FOUR new subscriptions at \$1 each, an Ideal Hunting Knife, made by W. L. Marble and listed at \$2.50; or a 32 caliber, automatic double action revolver, made by Harrington & Richardson Arms Co.

FIVE new subscriptions at \$1 each, a copy of *Cruisings in the Cascades*, cloth; or a set of Nehring's Convertible Amplisopes, listed at \$5.00; or an Ideal Hunting Knife made by W. L. Marble, and listed at \$3; or a pair of lock lever skates, made by Barney & Berry, listed at \$4.50; or a J C Hand trap made by the Mitchell Mfg. Co., listed at \$4.; or a Bristol Steel Fishing Rod, listed at \$6, or less; or a Yawman & Erbe Automatic Reel, listed at \$6 to \$9.

SIX new subscriptions at \$1 each, a Hawkeye Refrigerating Basket made by the Burlington Basket Co., or one dozen Eureka golf balls listed at \$4; or a Pocket Poco B 3¼x4¼, made by the Rochester Optical & Camera Co., listed at \$9; or a pair of horsehide hunting boots, made by T. H. Guthrie, Newark, N. J., and listed at \$10.

SEVEN new subscriptions at \$1 each, a copy of *The Big Game of North America*, or of *The American Book of the Dog*, cloth, or one set

Lakewood golf clubs, 5 in number, listing at \$5; or a series IIB or IID Korona Camera, made by the Gundlach Optical Co., listed at \$10.

EIGHT new subscriptions at \$1 each. A series I, 4x5, Korona Camera, made by the Gundlach Optical Co., listed at \$12. or an Acme single shot gun, made by the Davenport Arms Co., and listed at \$8.

TEN new subscriptions at \$1 each, a Cut-Glass Salad Bowl, made by Higgins & Seiter, and listed at \$4.50; or a Waterproof Wall Tent 7 x 7, made by Abercrombie & Fitch, and listed at \$8; or a Rough Rider rifle telescope, made by The Malcolm Rifle Sight Mfg. Co., and listed at \$12; or a Pneumatic Camp Mattress, with pillow listed at \$18.

TWELVE new subscriptions at \$1 each, a Peabody Carbine valued at \$12; or a Davenport Ejector Gun, listed at \$10., or a Cycle Poco No. 3, 4x5, made by the Rochester Optical & Camera Co., listed at \$15; or an 8 ft. folding canvas boat, made by the Life Saving Canvas Boat Co., listed at \$29.

FIFTEEN new subscriptions, \$1 each, a Shakespeare Reel, Silver Plated, listed at \$15; or a set of rabbit plates made by Higgins & Seiter, and listed at \$8, or a Field Glass made by Gall & Lembke; or a Kenwood Sleeping Bag, complete, with canvas cover, listed at \$16; or a Bulls-Eye rifle telescope, made by The Malcolm Rifle Sight Mfg. Co., and listed at \$16; or a 10 ft. special canvas boat, made by the Life Saving Canvas Boat Co., and listed at \$35.

TWENTY new subscriptions at \$1 each, a 14-karat Gold Hunting-case Watch, with Waltham Movement, listed at \$20; or an Elita single shot gun, made by the Davenport Arms Co., and listed at \$18., or an Acme Folding Canvas Boat, No. 1, Grade, A listed at \$27; or a Mullins Buck Boat, listed at \$20.

TWENTY-FIVE new subscriptions at \$1 each, an 11-foot King Folding Canvas Boat, listed at \$38; or a 4 x 5 Planatic lens, made by the Rochester Lens Co., and listed at \$25.

THIRTY new subscriptions at \$1 each, a Waterproof Tent, 14½ x 17, made by Abercrombie & Fitch, and listed at \$25; or a Field Glass, made by C. P. Goerz.

THIRTY-FIVE new subscriptions at \$1 each, a 14-foot King Folding Canvas boat, listed at \$48.

FORTY new subscriptions at \$1 each, a Savage .303 Repeating Rifle; or a No. 10 Gun Cabinet, made by the West End Furniture Co., and listed at \$32.

FIFTY new subscriptions at \$1 each, a No. 20 Gun Cabinet, made by the West End Furniture Co., and listed at \$38.

TWO HUNDRED new subscriptions at \$1 each, a strictly first class upright piano, listed at \$750.

Address, **Recreation** 23 West 24th St.  
New York

# First Aid in the Home

In the emergency hospitals POND'S EXTRACT, *the old family doctor*, is valued because of its power to stop bleeding; because of its efficacy in reducing inflammation; in relieving pain; in preventing blood poison! It's the remedy that

## Saves Life

For the home there is no other "first aid" so useful, so sure as POND'S EXTRACT.

Beware of watered witch hazel, often offered as a substitute on the plea of cheapness. At its best it is worthless; at its worst it is dangerous. If you want to be sure you must get POND'S EXTRACT.

Sold only in sealed bottles under buff wrapper.

Nothing in photography is more injudiciously used than the color screen with orthochromatic plates. It has its value, but its constant employment without any consideration of the subject is an abuse of a good and valuable adjunct. Frequently it depresses the blues and violets to such an extent as to give a flat, dull effect, and often destroys all atmosphere in a picture. When blues and violets are in the same subject with yellows and oranges, and there is danger that the former may be too self-asserting and come out too brilliant, one may use a color screen, but then judgment is demanded in selecting the depth of color requisite. All the values in a subject may be reversed by improper use of a screen.—The Camera.



### Lovely Complexion FREE.

A Trial Package Mailed FREE which will give any lady a beautiful complexion. It is not a face powder, cream, cosmetic or bleach, but is absolutely pure and you can use it privately at home. It permanently removes moth patches, redness, crow's feet, pimples, blackheads, flesh-

worms, sallowness, freckles, tan, sunburn, and all complexion disfigurements. Address,  
MADAME M. RIBAULT, 5372 Elsa Bldg., Cincinnati, O.

# Jaeger

## IN FALL

### Is a Boon for All

This unique underwear is no fad—no experiment.

The highest medical authorities attest its worth.

A quarter-century's success proves it. Made of the finest Australian wool, and easily outlasts the best in other brands. Is therefore the best economizer, inasmuch as it saves both health and money.

ILLUSTRATED CATALOGUE FREE

### DR. JAEGER'S S. W. S. CO'S OWN STORES

NEW YORK: 306 Fifth Ave., 157 B'way

BROOKLYN: 504 Fulton Street

BOSTON 230-232 Boylston Street

PHILADELPHIA: 1510 Chestnut Street

CHICAGO: 82 State Street

AGENTS IN ALL PRINCIPAL CITIES

# Going Fishing?

Well fixed for rods? If not,  
send me 5 yearly subscriptions to

## **RECREATION**

and get a Bristol Steel Rod—  
any one listing at \$6.00 or less.

---

---

Everybody knows what a Bristol  
Steel Rod is. It is equal in  
strength, durability, suppleness,  
and all the other good qualities to a  
split bamboo rod costing \$20.

This is a great opportunity  
and holds good only **SIXTY**  
days.

Sample Copies of Recreation  
for use in canvassing fur-  
nished on application.



# TALES OF ADVENTURE.

Rare Hunting and Fishing Stories.

I have a few sets of Volume 3 of RECREATION, July to December, inclusive, 1895. These are handsomely bound in cloth, with leather backs and corners.

Here are the titles of a few of the choice stories in the book.

- Woodcock on the Islands.**  
Illustrated. F. W. G. Johnson
- The Gordon Setter.**  
Illustrated. Dr. J. Whitaker
- Salmon Fishing in Labrador.**  
Illustrated. Col. Charles E. Fuller
- Coursing with the Greyhound**  
Illustrated. L. F. Bartels
- A Bald-Faced Grizzly in Camp.**  
Illustrated. M. W. Miner
- Where Leaps the Ouananiche.**  
(Poem.) Dr. E. L. Tiffany
- Fly Fishing** ..... Dr. M. G. Ellzey
- A Half Hour With the Quail.**  
Dr. E. P. Kremer (Juvenis).
- A Deer Drive with Spokane Indians.**  
Illustrated. Lieut. W. R. Abercrombie
- An Indian Horse Race.**  
Maj. F. M. Bernard
- The Old Kentucky Rifle.** (Poem.)  
Illustrated. Capt. J. W. Crawford
- A Mystery of the Tetons.**  
Illustrated. Ed. H. Trafton
- Pheasant Shooting.**  
Illustrated. Thomas G. Farrell
- Sitting Bull's Last Medicine.**  
Illustrated. Margaret Gray Brooks
- Crossing the Plains 30 Years Ago.**  
Illustrated. Gen. John Gibbon, U. S. A.
- A Mountain Lion Hunt by Night.**  
Illustrated. Robert Meade Smith, M.D.
- Trouting on Clark's Fork.**  
Illustrated. Gen. F. W. Benteen, U. S. A.
- Ducking off Machipongo.**  
Illustrated. W. J. Bogert
- A Youthful Guide and a Prize Bighorn.**  
Illustrated. Hon. I. N. Hibbs
- A Wild Goose Chase.**  
Illustrated. A. E. McKenzie
- A Tempestuous Cruise.**  
Illustrated. Commodore Chas. Pryer
- Hans the Wolf Hunter.**  
(Poem.) Illustrated. S. N. McAdoo
- How Some Women Went Shooting.**  
Illustrated. Julia C. Welles

These books will be sold at \$2.00 each, and when the present supply is exhausted there will never be any more. If you want a copy remit at once. Address,

**RECREATION,** 23 W. 24th St.,  
New York City



## Club Cocktails

Famous the world over for purity. They never vary. The secret of their perfect blend is that they are kept six months before being drawn off and bottled. Be sure you have them in your camp, on the yacht, and on your outing trips wherever you go. They are ready and require no mixing. Simply pour over cracked ice.

For Sale by all Fancy Grocers and Dealers

**G. F. HEUBLEIN & BRO.**  
29 BROADWAY, N. Y. HARTFORD, CONN.

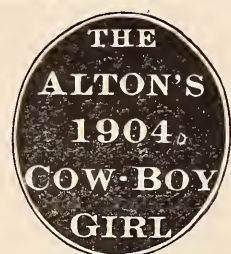

TRADE-MARK.

"Sequel to the Fencing Girl."

Copyright, 1903, by Chicago & Alton Railway.

### ART CALENDAR

Four graceful poses from life; figures ten inches high, reproduced in colors by a process far superior to last year's calendar. Highest example of lithographic art.

#### "THE ONLY WAY"

to own one of these beautiful calendars is to send twenty-five cents with name of publication in which you read this advertisement, to GEO. J. CHARLTON, Gen'l Passenger Agent, Chicago & Alton Railway, CHICAGO, ILL.  
The best railway line between CHICAGO, ST. LOUIS, KANSAS CITY and PEORIA. Take the "Alton" to the St. Louis World's Fair, 1904.



FRONT OF BICYCLE BOX.

# Leaders—because the Best. Bicycle Cards.

Used in every civilized country  
of the world.

They wear well.

Sold by dealers everywhere.

The U. S. Playing Card Co.  
Cincinnati, U. S. A.

HOYLE for 10c. in stamps—128 pages.  
Address Dept. 23.

For Duplicate Whist, best of card games, use Paine's Trays  
Lessons free with each set of trays. Write for particulars.

Already many thousands of people are wondering what they are going to get for Christmas presents. Other thousands are wondering what they are going to give their friends. If you wish to make a present to a man or a boy who is interested in shooting, fishing, amateur photography, or nature study, give him a year's subscription to RECREATION. Nothing you can possibly buy for \$1 would give him so much pleasure as 12 issues of this magazine. Come early and avoid the rush.

Allow me to thank you for the fine Al Vista camera sent me.

H. J. H., Edmonton, Alta.

I have been a constant reader of RECREATION ever since I knew there was such a splendid magazine printed. It has completely changed my views on the game question. Although I do not hunt often I am a lover of sport.

S. A. Mehaffey, Winterset, Ia.

Sailor—Want to buy a parrot, lady?

Lady—Does he swear?

Sailor—No, but if yer wants to pay er dollar more I kin get yer one what cusses elegant.—Columbia Jester.

Accept my sincere thanks for the Bristol rod sent me. It suits me exactly.

N. A. Platt, Albany, N. Y.

<p>Size <math>\frac{3}{4}</math> Standard 3 ft. x 6 ft.</p> <p>Strongly Constructed and Beautifully Finished</p>		<p>Quickest Solid Rubber Cushions Best Vermont Slate Bed French Billiard Cloth</p>
	<p><b>INDIANAPOLIS COMBINATION TABLE</b> Billiard—Pool—Library—Dining</p> <p>Best value ever offered. Elegant selected oak—Antwerp finish. Library or Dining Table with top on—Billiard and Pool Table when top is removed. Equipped with complete Billiard and Pool outfit of regulation quality throughout. One dozen styles Combination Billiard or Pool Tables, \$30 to \$150 Freight prepaid. Ask for our illustrated catalogue. It's FREE.</p> <p><b>COMBINATION BILLIARD MFG. CO.</b> 33-43 INGALLS ST., INDIANAPOLIS, IND.</p>	<p>\$30 TO \$150</p>

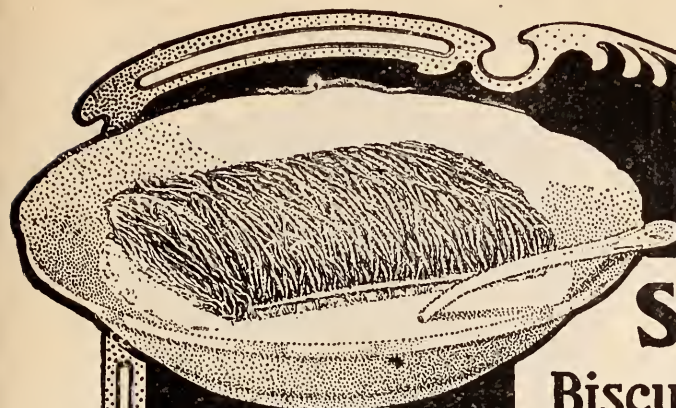

SHREDDED WHEAT BISCUIT  
WITH  
CREAM

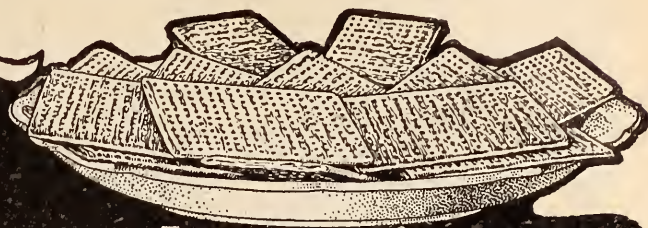

TRISCUIT AS TOAST



TRISCUIT WITH COCOA

## SHREDDED WHEAT <sup>155</sup>

**Biscuit and Triscuit** completely nourish the entire body and brain and are the only naturally short, porous foods made from wheat without the use of fats, yeast or chemicals of any kind.

**SHREDDED WHOLE WHEAT BISCUIT** is staple in every well-provisioned larder and is the reliance of the thoughtful housekeeper because it can be combined with fruits, preserves and vegetables, in making over 250 varieties of all-course dishes. It stands conspicuously alone as a cereal for morning, noon and night.

**TRISCUIT**, the appetizing wafer is so baked by electricity that all the rich, nutty flavor of the Whole Wheat is retained. There are many original ways of serving it in addition to its standard uses as bread, toast and as a successor to crackers. It makes delicious cheese toast and sandwiches, and when dipped in icing is transformed into healthful sugar wafer.

Place Biscuit and Triscuit in warm oven to renew crispness.

"I have been an invalid for three years; have tried the different breakfast foods, but find that *Shredded Whole Wheat* is the only food that I do not tire of and the only one which when used constantly agrees with me." **ETHEL M. SECOND, Ripley, N.Y.**

Shredded Whole Wheat Biscuit and Triscuit are sold by all grocers.

The Natural Food Company

Niagara Falls, New York

Makers of Shredded Whole Wheat Products

To remove pyro-stain, immerse in a clearing bath as follows:

Protosulphate of iron.....	3 ounces
Alum .....	1 ounce
Citric acid.....	1 ounce
Water .....	20 ounces

Prevention is better than cure, however; therefore, immerse the negatives in the above as soon as they are taken from the fixing bath. After clearing the negatives wash them well.—Exchange.

The fundamental rule of picture composition is simplicity. Avoid crowding. It reduces the interest. Concentrate on one principal object or group of objects. The beginner seems anxious to introduce all the matter and detail possible into his picture. He is beset by the temptation to make his picture as full and as interesting as possible, forgetting that by elimination of conflicting matter his result will gain instead of losing.—The Photo-American.

**Fox Squirrels:**—Send me 6 yearly subscriptions to RECREATION and I will send you a pair of these pretty little animals. For 3 subscriptions I will send a pair of flying squirrels. Safe delivery guaranteed to any part of United States or Canada. Squirrels are my specialty.

E. F. Pope, Colmesneil, Tex.

## The Buffalo Is Well Nigh Extinct

And every nature lover wants a relic of him. Here is a chance to get it:

I have in stock a limited number of buffalo horns, highly polished and fitted with nickel plated flanges at the base, so that they can be screwed on the wall, thus forming

## A Novel and Effective Gun Rack

So long as the supply lasts I will give a pair of these horns for

## 3 Yearly Subscriptions to RECREATION

Sample copies for use in canvassing furnished on request. Address

Recreation, 23 W. 24th St., New York

## SQUIRES' SIBERIAN MOOSE HUNTING BOOTS & SHOES

Made only by **HENRY C. SQUIRES & SON**  
20 Cortlandt St., New York

The **leather** is waterproof, fine grained, tough and pliable. The **linings** are russet calfskin. The **soles** are best waterproof anhydrous oak leather, **stitching** of silk, English back stays, bulldog toes, extra heavy **eyelets**, **Pratt fasteners** and **hand made throughout**. Price **\$7.50** net. Short Boots **\$8.50**, Knee Boots **\$10**, Cavalry Style Boots **\$12**. Special circular giving detailed information free for the asking.



Mention RECREATION.

## IN YOUR OUT DOOR LIFE YOU WILL NEED A Duplex Fork

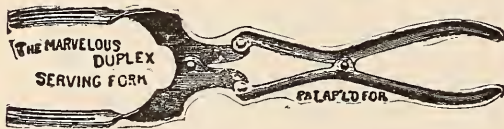

for handling hot potatoes, ears of corn, boiled eggs, and other hot food, and you will find it indispensable for use with pickles, fish and meats that an ordinary fork will break. The forks are always open and ready for use, and with a slight pressure on the handle anything can be easily taken hold of without fear of breaking.

**Postpaid, 25 Cents**

**E. A. LYFORD**, 3090 Gilbert Ave., Cincinnati, O.  
Mention RECREATION.



## Shooting Jacket \$ 3.00

**G**UARANTEED all wool, seamless, elastic, close fitting, but not binding, comfortable and convenient. Designed especially for duck shooters, trap shooters, etc., but suitable for all out-door purposes. Must be seen to be appreciated. Made only in two colors—dead grass and Oxford Gray.

Send us your address for one of our Gun Catalogs

**The H. H. KIFFE CO.**, 523 Broadway, N. Y.

## MEXICAN OPAL AND SOMBRERO FREE WITH EACH SUBSCRIPTION TO RECREATION.

To anyone subscribing to RECREATION through me, I will send free a beautiful genuine Mexican Opal as large as a pea, together with a miniature Mexican Sombrero, made of silver and horsehair beautifully dyed. Arthur Thomson, Box 332, San Antonio, Texas.

The Korona camera sent me as a premium is entirely satisfactory.

G. L. Woodard, Timmath, Colo.

## The Reason the LUTHER HAND-MADE GLOVE will not rip



Machine sewing cuts itself



Hand sewing cannot.

## A Practical Hunting and Driving Glove

Made for practical, comfortable, durability. No Oil. No Odor. No Animal Glue. Practically seamless. Cannot Rip. Unaffected by moisture of any kind. If soiled, may be washed with soap and hot water, without injury. The Luther Fastener is adjustable, fits any wrist and cannot get out of order. Illustrated booklet, samples and self measurement rule on application.

If you prefer to buy through your dealer send us his name

**No. 308 Driving Glove** postpaid anywhere **\$1.50**, made to measure **\$2.50**,  
**No. 320 Gauntlet**, " " " **3**

**J. P. LUTHER GLOVE CO.**, 536 Pearl St., Berlin, Wis.



Do you want a Good, Reliable,  
Substantial, Well Made

## Single Barrel Shot Gun

If so, send me

10 YEARLY SUBSCRIPTIONS

and I will send you such a  
Gun as a premium

It is made by the *DAVENPORT ARMS CO.*, and this means it is made of good material and that only good workmanship is put on it.

This is one of the many remarkable opportunities *RECREATION* is offering to men and boys to fit themselves out completely for shooting and fishing.

Sample Copies for Use in Canvassing  
Furnished on Application.

Address

# RECREATION

23 W. 24th St., New York City.

Bromide prints, especially enlargements, frequently contain spots which must be removed, or, perhaps, a background is uneven and must be smoothed, or, again, certain portions of the prints may need strengthening. Crayons, or various coloring matters, applied with a brush, are generally used for this purpose, but one of the most simple and effective methods is to expose to the light a sheet of the same paper from which the print is made, and then develop, fix, and wash it in the usual way. While the paper is still wet hold it, gelatin side down, over boiling water. This operation softens the gelatin to such an extent that the emulsion may be easily scraped off. Add warm water to the emulsion until a dark paste is formed. Apply this paste, or coloring matter, to the print with a brush in the usual manner. This substance being the same as the emulsion of the paper, its presence is not easily detected. The shade of the coloring matter is controlled by the development of the exposed paper and is, of course, darker, as the exposure is longer and as the development is carried farther. This is an admirable method for working out the defects of bromide prints.—Exchange.

The Mullins duck boat you sent me for getting 20 subscriptions is buoyant, easy rowing, light of draught, and, altogether, an ideal hunting boat.

J. S. McCain, Washington, N. J.

# PRESIDENT SUSPENDERS

For a Gift



In Beautiful Boxes For  
**CHRISTMAS**  
All stores 50c and \$1.00  
or mail prepaid

The C. A. Edgarton Mfg. Co., Box 219, Shirley, Mass.

Paris Exposition, 1900; Gold Medal and Highest Award

## THEY FIGHT FOR SPRATT'S



**SPRATT'S PATENT DOG CAKES** are the BEST and CHEAPEST.

**SPRATT'S PATENT DOG CAKES** will keep a dog in show form and working condition.

**SPRATT'S PATENT DOG CAKES** are fed exclusively at the leading dog shows of Canada, America, Great Britain, France, Germany, etc.

**SPRATT'S PATENT DOG CAKES** are used by the leading kennel owners and breeders throughout the world.

**SPRATT'S PATENT DOG CAKES** are sold by leading grocers, sporting goods dealers, druggists, etc.

Write for our Catalogue "Dog Culture," with practical chapters on the feeding, kenneling and management of dogs, also a chapter on cats, mailed on receipt of two-cent stamp.

We also manufacture specially prepared food for dogs, puppies, rabbits, cats, poultry, game, pigeons, fish, birds, etc.

**SPRATT'S PATENT** 450 Market St., Newark, N. J.  
714 S. 4th St., St. Louis, Mo.  
1324 Valencia St., San Francisco, Cal.

(America) Limited

# TO AMATEUR PHOTOGRAPHERS

Here is a Chance  
to Get a  
FINE CAMERA EASILY

A 4x5 Weno Hawk-eye film camera listing at \$8, for 5 yearly subscriptions to RECREATION. A No. 3 folding Weno Hawk-eye film camera, listed at \$15, for 10 yearly subscriptions to RECREATION.

These are both neat, compact, well made and handsomely finished cameras, capable of doing high-class work.

*Sample copies for use in canvassing  
furnished on request.*

Address RECREATION

23 West 24th St.

NEW YORK CITY

# 30 NIGHTS FREE



TRADE

MARK

We make no argument on quality this month. We state as our belief, born of 50 years in mattress making, that an OSTERMOOR is the most comfortable and restful mattress ever made at any price—also the most durable. It is sold on its merits—not on its advertising. Time and usage, the destroyers of all things, have no apparent effect on the

## Ostermoor Patent Elastic Felt Mattress \$15.

You don't have to depend on the judgment of others. Decide for yourself. Sleep on it 30 nights from date of receipt, and if it is not better in cleanliness, durability and comfort than any \$50 hair mattress ever made—if it is not all you even HOPED for, return it at our expense and your money will be immediately refunded without question. This is

**OUR UNANSWERABLE ARGUMENT.**

**SEND FOR OUR FREE BOOK**

whether you want a mattress or not—interesting information on comfort and the OSTERMOOR. There is no other mattress as good as the OSTERMOOR, and we want you to know why—we challenge comparison. It illustrates the various uses to which the Patent Elastic Felt is put—Pillows, Window Seat Cushions, Boat Cushions, Church Cushions, etc.

STANDARD SIZES AND PRICES:			
2 feet 6 inches wide,	25 lbs.,	- - -	\$ 8.35
3 feet wide,	30 lbs.,	- - -	10.00
3 feet 6 inches wide,	35 lbs.,	- - -	11.70
4 feet wide,	40 lbs.,	- - -	13.35
4 feet 6 inches wide,	45 lbs.,	- - -	15.00
All 6 feet 3 inches long.			
In two parts 50c. extra.		Special sizes, special prices.	
Express charges prepaid to any place.			

Look out for the frauds that are offered everywhere. It's not "felt" if it's not an "OSTERMOOR." The name "OSTERMOOR" and our trade mark label are sewn on the end of every genuine mattress. "Mistakes" will happen, you know.

**OSTERMOOR & CO., 114 Elizabeth Street, New York**  
 Canadian Agency: The Alaska Feather and Down Company, Ltd., Montreal.

---

# HERE IS ANOTHER!

If you will send me

**Thirty Yearly Subscriptions**

to

**RECREATION**

I will send you

**A No. 10 Goerz Trieder-  
Binocular Field Glass**

**Listed at \$38**

Every well-informed man knows the great power of this modern prismatic field glass. It is indispensable to every hunter, and is one of the latest and best on the market.

I have but a few of these instruments on hand and the offer will be withdrawn as soon as the supply is exhausted. Therefore, if you want one

**START IMMEDIATELY**

---

---

Sample copies of RECREATION for use in canvassing furnished  
on application



## A SUGGESTION FOR CHRISTMAS.

Have you commenced to think of Christmas presents? If so, here is a suggestion:

A yearly subscription to RECREATION furnishes one of the most delightful, instructive, entertaining Christmas presents you can possibly give a man or boy who is interested in nature, in fishing, shooting, amateur photography; or who is fond of the woods, the fields, the mountains, the lakes or the rivers.

Many of the presents which people give their friends afford pleasure only for a few days, or weeks. A subscription to RECREATION means solid comfort a whole year. It reminds your friend 12 times during the year of your kindness and generosity. There are many men and women who for 5 years past have annually sent in long lists of names of friends, accompanied with a check, in order that those friends might be made happy a whole year. Would it not be well for you to adopt this plan?

Try it and see how grateful the recipient will be.

**Free:** If you send your subscription to RECREATION through me or direct to the office to be placed to my credit, I will send you, free of charge, any one of the articles mentioned below:

Shot gun bench crimper, sells for 75 cents, in 10-12 16-20 gauge.

Shot gun cleaning rod, three attachments, sells for 50 cents, in 10-12 16 gauge.

Micrometer powder and shot measure, adjustable, and for both black and smokeless powder, sells for 65 cents.

U. S. Government rifle cleaner, any caliber, with attachments, sells for 60 cents, packed in neat canvas bag.

A duck, snipe or turkey call, sells for 75 cents each, best made.

A hand painted sporting picture, suitable for framing, and just the thing for your den, worth \$1.50.

"Hunting in the Great West," by G. O. Shields. H. S. Hill, 815 11th Street, N. E., Washington, D. C.

IN ANSWERING ADS PLEASE MENTION RECREATION.

# FAY & BOWEN

## Motors & Launches

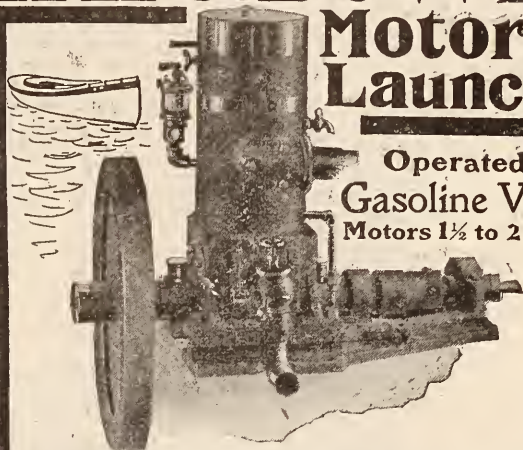

Operated by  
Gasoline Vapor  
Motors 1½ to 25 H.P.

THE Fay & Bowen Marine Motor is a revelation to those who have used others. Reliable, safe, durable and easy to operate. Remarkable speed control. Best of all, it starts when you start it. No handle or crank is used. Our patent igniter is absolutely unique and always instant and positive in action. It is really the only perfect and satisfactory igniter.

Motors complete from 1½ to 25 H. P. ready for installation. We also build handsome launches with motors installed and ready to run

Send for Catalogue.

**Fay & Bowen,**

28 Mill Street,

Auburn, N. Y.

## THE KENYON SILKIEN ROD

In all the world no Rod like this. Covered with a solid invisible silk winding from butt to tip.

**NO FERRULES**; but joined by splices easily and quickly adjusted.

In Action, Strength and Beauty it has no equal.

Made by hand—to order only. Send for booklet giving full description of its manufacture and testimonials.

Mention RECREATION.

J. M. KENYON, Maker, 214 12th St., Toledo, Ohio

## BIG MONEY In Mail-Order Business

People are buying more by mail than ever before: one mail order house does a business of a million dollars monthly; another receives 2,000 letters daily, nearly all containing money; mail order trading is unquestionably the business method of the future. The field is large, the possibilities unlimited. Let us send you our plan for starting beginners; it covers every point. Enclose stamp.

CENTRAL SUPPLY CO., Kansas City, Mo

## "SMALLEY"

### MARINE GASOLINE MOTORS

are designed for use in any kind of a boat requiring from 1½ H. P. to 20 H. P. Either single or double cylinder. Simple, mechanical, durable, positive, handsome, economical and moderate priced. Our speed control, propeller equipment and many other features should be investigated.

Send for illustrated catalogue.

Address Dept. C.

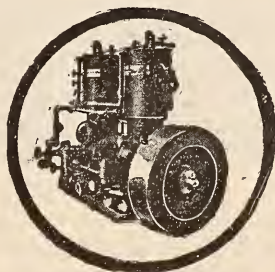

### OUR NEW PLANT

is the largest in the world devoted exclusively to the manufacture of marine gasoline engines. We operate our own pattern, foundry forge and machine departments. We manufacture every part of our engines from fly wheel to propeller.

Every engine is connected to its propeller and given an actual water test before placed in purchaser's hands.

SMALLEY MOTOR CO., Ltd.,

Bay City, Mich., U. S. A.

# THE LATEST, SAFEST AND BEST CANVAS BOAT

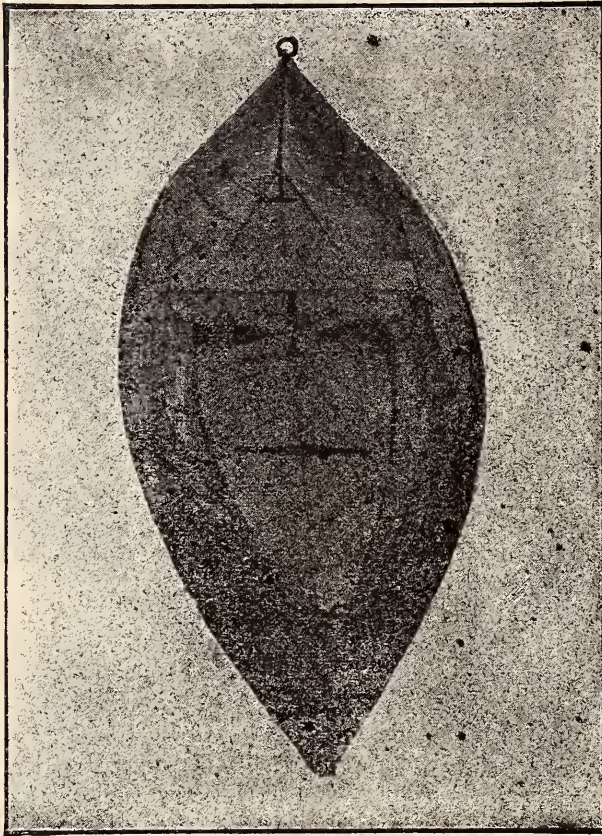

Is what we offer you. A Boat built on modern lines that will prove a pleasure to own and use. Selected materials used throughout, and it comes to you **guaranteed** the best. A handy and safe boat for fishing and shooting. Send 4 cents in stamps for catalogue and reliable testimony.

Mention RECREATION.

**LIFE SAVING FOLDING CANVAS BOAT CO.**

**Kalamazoo, Mich.**



Latest patent and improved Canvas Folding Boat on the market. Puncture proof; Tempered steel frame. No bolts to remove. Folds most compact of any boat made.

**Wanted:**—To communicate with a few gentlemen who would like to join a country club, having good hunting and fishing privileges. Property located near railway station, 170 miles from New York. Very attractive proposition. Address W. T. Fales, 41 West 26th St., New York.

**For Sale:**—Winchester Single Shot Rifle, 32-40, with Mid Range Vernier sight, Sporting rear sight, and Lyman Combination front sight; also reloading tools. Practically new and in perfect condition. Price, \$15. No exchange.

I. P. Tafft, Box 474, Norwich, Conn.



**ACME FOLDING BOAT CO., MIAMISBURG, O.**

U. S. Government who prefer our boats. Received medal and award at Chicago World's Fair. If you investigate we will get your order. Mention RECREATION.

**Acme Folding Boat Company, Miamisburg, O.**

## A SPORTSMAN'S BOAT

# Mullins' "Get There" Steel Duck Boat



14 ft. long, 36-inch beam. **PRICE, \$20** Crated on cars Salem.

**Endorsed by Thousands of Sportsmen.** Air Chamber each end. Always ready. No repairs. Send for handsome free book. **Mention RECREATION.**

**W. H. MULLINS, 228 Depot Street, Salem, Ohio**



## SURF FISHING FOR BASS IN FLORIDA

with a No. 17 BRISTOL STEEL FISHING ROD. Results: a 26 lb. bass and several smaller ones. Buy a BRISTOL ROD for your Florida or California fishing; the Nos. 21 and 22 Rods described in our catalog are made especially for heavy work—a postal will bring you the catalog. Our Rods are sold by all dealers.

The HORTON MFG. CO., No. 73 Horton Street,  
BRISTOL, CONN., U. S. A.

# KEEP YOUR HANDS WARM

Send me 2 yearly subscriptions to *Recreation* and I will send you a pair of **Leather Hunting Gloves** made to your measure, by the Luther Glove Co., Berlin, Wis.

*Sample copies for use in canvassing furnished on request*



11-foot Special

**Folding Canvas Boats** were not satisfactory until the **King** was produced. **It's a revelation** in boat construction. Nothing like it ever made **Nonsinkable. Can't turn over. Puncture-proof.** Wear longer than a wooden boat. **No repairs.** No cost for storage. **Always ready.** Folds into a small, neat package,—**carry by hand.** Used by the U. S. Navy. They are simply wonderful. A thoroughly patented article. Beware of imitation. Made only by ourselves.

A catalogue of 70 engravings and 350 testimonials sent on receipt of 6 cents.

Mention RECREATION.

**King Folding Canvas Boat Co.**  
Kalamazoo, Mich. U. S. A.

---

# SLEEP

IS TIRED NATURE'S  
SWEET RESTORER

After a hard day's tramp, you must have

## A Good Night's Rest

in order to fit you for the next day's work. Better to sleep on a good bed without your dinner, than sip at a banquet and then sleep on the cold, hard, wet ground. You can get

## A Recreation Camp Mattress

of rubber, with valve for inflating, made by the Pneumatic Mattress Co., and listed at \$18.

For 10 Yearly Subscriptions to

# RECREATION

---

---

*Send for Sample Copies*

Address RECREATION, 23 West 24th Street, New York



## B. Bernard

Buyer of Raw Furs and  
Ginseng Root.

150 Blecker St., New York.

Quotations sent on request.

**Taxidermists' Glass Eyes for  
Stuffed Birds  
and Animals**  
Oologists' and  
Entomologists' **Materials**  
Supplies

Send 5c. in stamps for catalogue

**FRED. KAEMPFER, 88 STATE ST.,  
Chicago, Ill.**

Taxidermy work done in all its branches

Mention RECREATION

## FOR SALE

The largest collection of Game Heads, Horns, and Antlers in America. A total of TWO HUNDRED AND FIFTY SPECIMENS, including many record heads and exceptional freaks and rarities. Full information and catalogue on application.

**A. E. COLBURN**

Bond Building, Washington, D. C.

## CUBAN BIRDS

I now have a collector in the field on the Island of Cuba, and will be able to supply specimens of any birds desired.

**R. D. HOYT, Taxidermist  
SEVEN OAKS, FLORIDA.**

## FOR SALE

The entire stock and good will of my Taxidermy Department, including mounted and unmounted birds, animals, elk and deer heads, reptiles, skeletons, rugs and shells.

Must sell on account of being compelled to devote my time to other departments.

This is one of the finest collections of its kind in the country.

Would be suitable for museum or curio hall.

Will sell cheap.

**EDW. S. SCHMID**

712 Twelfth Street N. W.

Washington, D. C.

**FREE!** Complete instructions for preserving and mounting Birds, Game Heads, Fishes, etc., etc., and also how to dress Skins with hair on for rugs and robes.

Hunters, Trappers, Anglers, Collectors and all others interested in saving trophies for decoration or sale, send stamp for free instruction. Mention RECREATION.

**MORRIS GIBBS, M. D.**

Level Street

Kalamazoo, Mich.



FORMERLY CALLED

**Horejs' Dog Biscuit**

Write for Samples and Prices to

**ST. PAUL BREAD COMPANY,**

Mention RECREATION.

St. Paul, Minn.

## Squab Book Free



Squabs are raised in 1 month, bring big prices. Eager market. Astonishing profits. Easy for women and invalids. Use your spare time profitably. Small space and capital. Here is something worth looking into. Facts given in our FREE BOOK, "How to make money with Squabs." **PLYMOUTH ROCK**

**SQUAB CO., 11 Friend St., Boston, Mass.**

## "Pigeons and All About Them"

F. M. GILBERT'S latest work. 264 pages, illustrated—strictly up-to-date. The only complete Pigeon Book published in the last twenty years. Cuts of all the best-known varieties. Standards of all varieties. Tells how to build loft, buy, mate, breed, feed, how to ship to customers, how to prepare for shows and ship to shows, how to prevent and cure disease, tells which are the best breeders and feeders, tells best varieties to breed in a city and which in small towns, tells how to mate for color—in fact, it tells just what it has taken the author forty-five years to learn by actual experience. Endorsed by all the leading fanciers in America. Hundreds of letters praise it. Fourth edition now out. To get it promptly send one dollar to **Frank M. Gilbert, Evansville, Ind.**

**FINE MOUNTED GAME HEADS,  
BIRDS, ETC., for sale at unheard-of prices.**

Send 10 cents for photos.

**JOHN CLAYTON, Taxidermist, Lincoln, Maine**



## SPORTSMEN

**SAVE YOUR BEAUTIFUL TROPHIES.  
LEARN TAXIDERMISTRY BY MAIL.**

Adorn your home and office with the prizes of the chase. Increase your income. Add tenfold to the pleasures of field sports. Make your gun a source of profit.

We teach the mounting of Birds, Animals, Heads, Tanning Skins and Furs, and collecting Insects and Eggs, successfully by correspondence. Standard methods, (no so-called "rapid systems" or "embalming") skilled faculty, reasonable tuition, satisfaction guaranteed. Endorsed by all leading Taxidermists and Standard Sporting Magazines. Now is the ideal season to study Taxidermy. Interesting catalog FREE. It's yours for the asking.

Write to-day.

**The Northwestern School of Taxidermy, (Inc.)**

411 A Bee Bldg.

The original and only School of Taxidermy in the World

Omaha, Neb.

A Pair of  
HIGH GRADE  
**Hunting Boots**

MADE BY T. H. GUTHRIE, NEWARK, N. J.



LISTED AT \$10

For 6 Yearly Subscriptions to

**RECREATION**

TRY THEM

For particulars Address

**RECREATION** 23 West 24th Street  
NEW YORK CITY

## SOME GOOD GUIDES.

Following are names and addresses of guides who have been recommended to me, by men who have employed them; together with data as to the species of game and fish which these guides undertake to find for sportsmen.

If anyone who may employ one of these guides should find him incompetent or unsatisfactory, I will be grateful if he will report the fact to me.

## ALASKA.

Edwin Edelmann, Kenai, Cook's Inlet, moose, bear, caribou, mountain sheep, ducks, grouse and trout.

## FLORIDA.

Carson Bros., Frostproof, bear, deer, turkeys, quail, snipe.

C. H. Stokes, Mohawk, deer, alligators, turkey, quail, and snipe.

## IDAHO.

John Ching, Kilgore, elk, bear, deer, antelope, mountain sheep, trout and grouse.

Chas. Petty's, Kilgore, ditto.

## MAINE.

H. R. Horton, Flagstaff, deer, bear, moose, caribou, fox, grouse and trout.

W. C. Holt, Hanover, moose, caribou, deer, grouse and trout.

Eugene Hale, Medway, ditto.

## MONTANA.

A. R. Hague, Fridley, elk, deer, mountain sheep, bear, grouse and trout.

Chas. Marble, Chestnut, ditto.

## NEW YORK.

Le Roy Still, Bayport, Long Island, ducks, quails, rabbits and grouse.

## WASHINGTON.

Munro Wyckoff, Port Townsend, deer, bear and grouse.

## WYOMING.

S. N. Leek, Jackson, elk, bear, deer, mountain sheep, antelope, grouse and trout.

James L. McLaughlin, Valley, elk, bear, deer, mountain sheep, antelope, grouse and trout.

## CANADA.

Wm. S. Andrews, Lillooet, B. C., deer, bear, mountain sheep, goats, grouse and trout.

B. Norrad, Boiestown, N. B., moose, caribou, grouse and trout.

Carl Bersing, Newcastle, N. B., moose, caribou, deer, bear and grouse.

## NEWFOUNDLAND.

John C. LeMoine, Birchy Cove, Bay of Islands, caribou, salmon and trout.

**BIG GAME IN MEXICO.** Bear, Mountain Lion, Jaguar, Deer, Antelope, Mountain Sheep, Wild Hog, Timber Wolf, Wild Turkey. We have a comfortable Hunting Lodge in the heart of the Sierra Madre, in Sonora, Mexico, 2½ days from El Paso, Texas. Our outfit is complete and we furnish everything and make your trip here one that will be pleasantly remembered.

**Rates: \$2.50 a day.** No extra charge for guides. Correspondence solicited. Mention RECREATION.

P.O. Address **CHIHUAHUITA LODGE**  
**Colonia Pacheco, Chihuahua, Mexico**

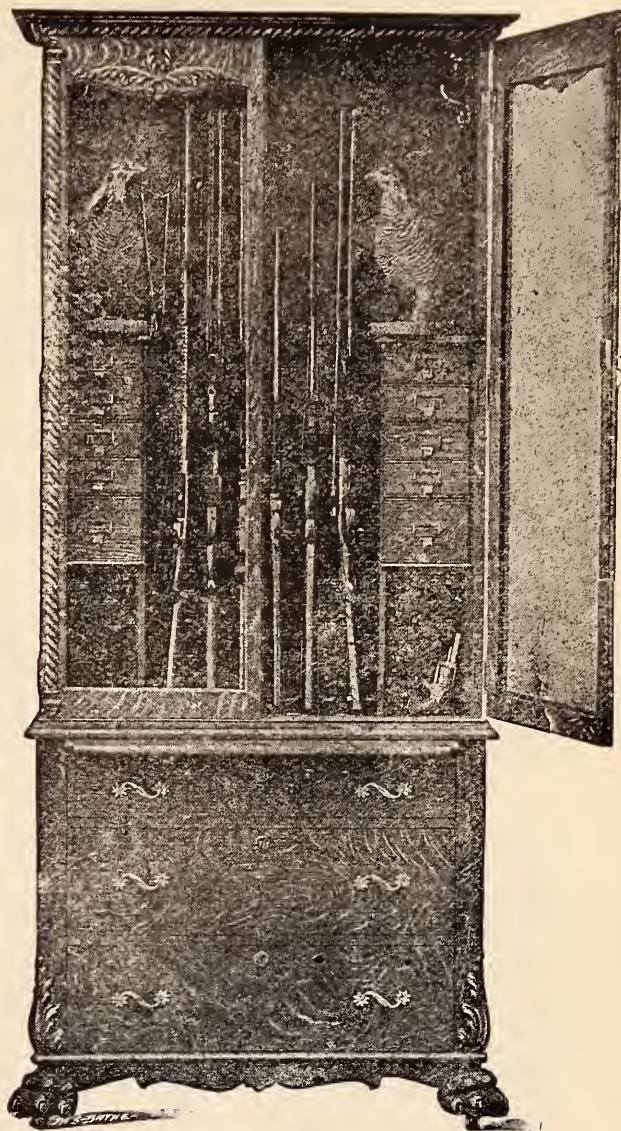

## For Christmas

Just send stamp for Catalog and order early. Mention RECREATION.

## WEST END FURNITURE CO.

SOLE MANUFACTURERS

WILLIAMSPORT, PA.

Date, \_\_\_\_\_ 190

G. O. SHIELDS,

Editor and Manager of RECREATION, 23 West 24th St. New York.  
Herewith find \$1.00 for which please send me RECREATION one year  
beginning with \_\_\_\_\_ number,

Name, \_\_\_\_\_

Remit by P. O. or Express Money Order, or New York Draft.

DETACH THIS, FILL OUT, AND SEND IN

RELICS OF A DISAPPEARING RACE

# Buffalo Skulls

WITH POLISHED OR  
UNPOLISHED HORNS

Also polished or unpolished horns in pairs or single. Polished horns tipped with incandescent electric lights; polished hunting horns; mirrors hung in polished horns, etc. These are decided novelties and are in great demand for sportsmen's dens, offices, club-rooms, halls, etc. Send for illustrated catalog. Mention RECREATION.

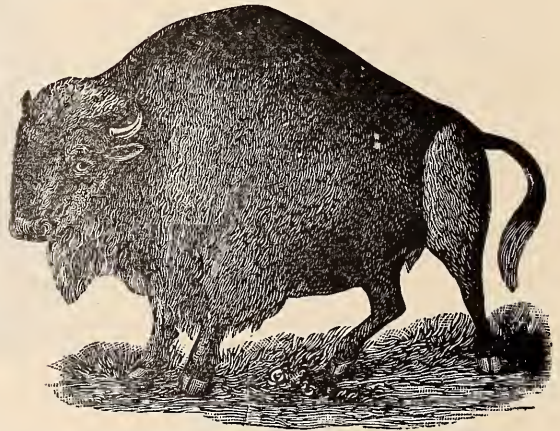

E. W. STILES

141 Washington St. Hartford, Conn.

I ordered one of Wing & Son's best pianos and my wife thinks it one of the best and sweetest toned pianos she ever played on. Wing & Son are agreeable, honorable people to deal with and any one of your readers who wishes a piano can do no better than to buy of Wing & Son.  
Minter Jackson, Janelew, W. Va.

I thank you for the Yawman & Erbe reel. My subscribers are delighted with RECREATION, and I am more than pleased with the premium.

August Mayer, Rochester, N. Y.

RECREATION is the best sportsmen's magazine published.

Chas. J. Wood, Utica, N. Y.

## APPLICATION FOR MEMBERSHIP IN THE L.A.S.

ARTHUR F. RICE, Secretary L.A.S., 23 W. 24th St., New York.

DEAR SIR: Enclosed \$1 for membership fee for one year.

I certify that I am eligible to membership in the L. A. S. under the provisions of the constitution, and refer to 2 League members (or to 3 other reputable citizens) named hereon.

Name \_\_\_\_\_

Street or P.O. Box \_\_\_\_\_

City or Town \_\_\_\_\_

References

Detach this, fill out and send in.



# PATENTS

promptly obtained **OR NO FEE.** Trade-Marks, Caveats, Copyrights and Labels registered. **TWENTY YEARS' PRACTICE.** Highest references. Send model, sketch or photo. for free report on patentability. All business confidential. **HAND-BOOK FREE.** Explains everything. Tells How to Obtain and Sell Patents, What Inventions Will Pay, How to Get a Partner, explains best mechanical movements, and contains 300 other subjects of importance to inventors. Address,

**H. B. WILLSON & CO.** Patent Attorneys  
786 F Street, N. W., WASHINGTON, D. C.

## The Foundations Of Large Fortunes

are made by investing the **FIRST** dollar where it will be **SAFE** and yet bring **LARGE RETURNS**

### OPPORTUNITIES ARE FEW

We have an opportunity that will please you. No gambling—no mining—oil, or other scheme. No risk—straight business—as legitimate and profitable as that of the Standard Oil Co.

### SHARES ONE DOLLAR EACH—OFFER LIMITED

If you haven't a dollar to spare we will give you a chance by **PAYING** you to show our offer to your friends. **LARGE ILLUSTRATED BOOK** and particulars **FREE.** You make a mistake if you don't answer this ad. It appears **But Once.** Address with stamp

**THE NUTRIOLA COMPANY, Dept. F**  
802 W. Madison St., Chicago, Ills.

## Cedaroleum!

The New Lubricant and Rust Preventive

It is colorless and you can use it anywhere on your gun or rifle. Manufactured of the purest chemicals, it meets a demand and need.

It is better than any oil or vaseline.

It is a specific for cleaning rifles and guns after using nitro powders, as well as black. Its peculiar substance makes it the finest lubricant for the mechanism.

It is put up in a neat tube with injector and is handy to carry in your pocket wherever you go.

Send for sample to-day. **Price, 15 Cents.**

Mention **RECREATION.**

**CEDAROLEUM COMPANY**

Trademark Registered.

**Perkinsville, Vt.**

**RECREATION** is the best sportsmen's magazine printed, and is also the best hog sticking implement of the day. It is far ahead of the butcher's knife. A knife will only kill hogs, but **RECREATION** makes them wish they had never been born.

Stanley Browne, Rat Portage, Ont.

## IF DUPONT SMOKELESS

cost more than other powders  
it would be worth the price.

IT

costs no more to specify

## DUPONT SMOKELESS

in your shells for fall shooting

## Newhouse Traps

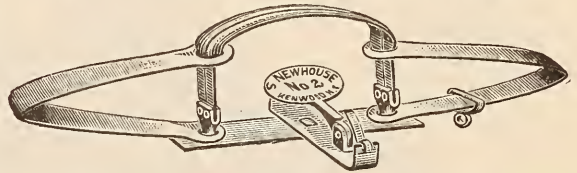

THE STANDARD FOR OVER FIFTY YEARS

Used by all professional hunters and trappers,  
who find that

**The Best Trap is the Cheapest**

Complete illustrated catalogue on  
application.

**ONEIDA COMMUNITY, LTD., Kenwood, N. Y.**

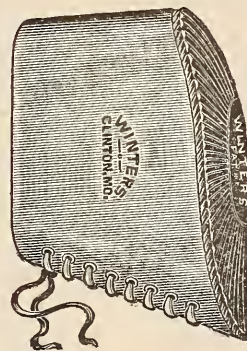

## THE 1902 Model

**LEATHER-COVERED** Pneumatic Recoil Pad is now perfect. No pump, no valve, no recoil, no flinch, no headache, no bruised shoulders, no money if not satisfactory and returned at once. **PRICE \$2.**

**J. R. WINTERS**  
Clinton, Mo.

Accept my sincere thanks for the beautiful Harrington & Richardson gun you had that firm send me. After a thorough test I am more than pleased with it.

Matt, Stumpf, Madison, Wis.

**For Exchange:—A Winchester Repeating Shot Gun for a French horn or alto.**

C. M. Jones, Jr., Union, Oregon.

## ANTI-RUST WICK PLUGS AT REDUCED PRICES

Arms fitted with Wick Plugs can not Pit or Rust

REDUCED PRICES

Shot Gun, per pair, \$1.00 postpaid

Shot Gun, per Plug, .50 postpaid

Rifles, per Plug, .50 postpaid

Give gauge and length of barrel

**HEMM & WOODWARD, Sidney, O.**

Write for Circulars. Mention **RECREATION**



# THE MALCOLM RIFLE TELESCOPE

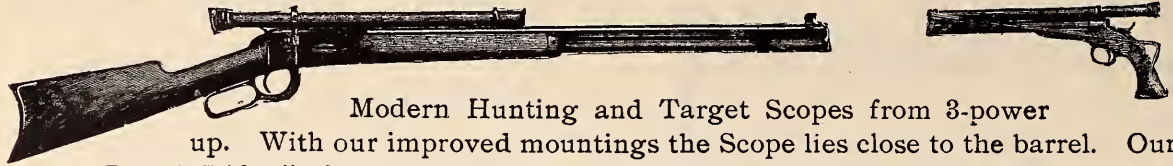

Modern Hunting and Target Scopes from 3-power up. With our improved mountings the Scope lies close to the barrel. Our "Rough Rider" of 3-power is an ideal hunting glass. Our "Bulls Eye" at 5 to 8-power is perfection itself for both hunting and target purposes.

SEND FOR 1903 CATALOGUE

Mention RECREATION.

## THE MALCOLM RIFLE TELESCOPE MFG. CO.

F. T. CORNISH, Mgr.

Established 1857

SYRACUSE, N. Y., U. S. A.

# WANTED

Every owner of a shot gun to learn all about our handy little Target Trap.

*A Card Brings the Information*

Mention RECREATION.

THE MITCHELL MFG. CO., London, Ohio



**"Collan-Oil"**

preserves leather and renders shoes and harness positively

**WATERPROOF**

Used by the U. S. the Army and Navy, and National Guard.

Send 25c. for trial can.

AGENTS WANTED

Write for terms and circulars

**J. R. BUCKELEW**

Dept. A. 111 Chambers St., N. Y.

Practical Common Sense  
in 6 Sizes.

**CAMP STOVE**



Either with or without oven. The lightest, strongest, most compact, practical stove made. Cast combination sheet steel top, smooth outside, heavy lining in fire box and around oven, holds its shape, telescopic pipe carried inside the stove. Burns larger wood and keeps fire longer than any other. Used by over 9,000 campers and only one stove returned.

For catalogue giving full particulars, mention RECREATION and address,

**D. W. CREE, Manufacturer, Griggsville, Ill.**

**KOENIG'S SHELL EXTRACTOR.**



Every shooter should have one—carry it in a vest pocket. Fits any gauge shell. Koenig's Gun Catalogue, Free.



10 Cts. Postpaid.

**E.G. KOENIG, NEW JERSEY'S LARGEST GUN HOUSE**

SOUTH BROAD ST., NEWARK, N. J.

**INDIAN CURIOS**

WHOLESALE & RETAIL  
CURIO DEALERS'  
SUPPLY DEPOT.





Bead Work, Baskets, Elk Teeth, Mexican Goods, Fossils, Minerals, Arrow-Heads, Pottery, Alaska Ivories, Shells, Agates, Photos, Great stock, Big Cata. 5c. stamps. Mention RECREATION. If a dealer, say so.

**L. W. STILWELL**

DEADWOOD . . . . . SO. DAKOTA

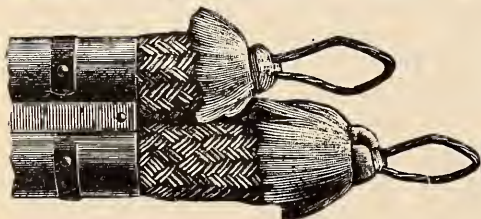
## BRADLEY'S ANTI-RUST ROPES!



For SHOT GUNS, RIFLES and REVOLVERS. They cannot rust or pit if these ropes are used. No more worrying to keep your fire arms in perfect condition. Sent postpaid, \$1 per set for Shot Guns; 50c. for Rifles; 25c. for Revolvers. Give gauge and length of barrel. Send for circular giving full particulars.

### BRADLEY'S SHOT GUN SIGHT

Makes wing shooting easy and certain. Scores greatly increased at trap and in field. Instantly attachable and detachable. Price, post-paid, 50 cents. Send for circular.

Address **C. L. BRADLEY, CLARKSVILLE, TENNESSEE.**  
Mention RECREATION.



A No. 19

## HAMILTON TAKE DOWN RIFLE

The best companion for a day in the woods. Both youths and maidens, men and women find it an ideal weapon. Light and strong. Shoots long and short 22 caliber cartridges and has automatic shell ejector. For small game or target practice it has no equal. Price ..... **\$200**

Our No. 15 Model, with a 4 inch shorter barrel, is practically the same weapon reduced to boy's size. Price **\$1.50**. Ask your dealer to show you Hamilton Rifles. If he cannot, write us for illustrated folder—FREE. **The HAMILTON RIFLE CO.,**  
Box 64, **Plymouth, Mich.**

# THE BAKER

THE GUN THAT'S SAFE

SO DURABLE TOO  
IT LASTS A  
LIFETIME



If you want to be right up in the front rank of style and efficiency shoot one of our **Special Paragons** with *Whitworth* or *Krupp* fluid steel barrels. We have other patterns also that would please you. Our "Quarterly" tells about them and other matters that would interest you. We will send it to you *free* a year if you want it.

**BAKER GUN & FORGING CO., 42 Liberty Street, Batavia, N. Y.**

## How is your Muscle?

Would you like to build it up?

## How are your Lungs?

Would you like to ex. and them?

## How is your Circulation?

Would you like to improve that?

If so, send me **6 yearly subscriptions** to RECREATION, accompanied by a money order for \$6, and I will send you a new

# PROFESSIONAL PUNCHING BAG

made by H. D. CRIPPEN, No. 52 Broadway, New York and listed at \$6.95.

There is a frame with the bag that you can attach to a door casing, a window casing or a wall, or a board fence, or anywhere else you may see fit to put it, and you will thus have a small gymnasium of your own. The Crippen bag is one of the liveliest ever devised, and if you will put 20 minutes a day on it, for a month, you will find a wonderful improvement in your muscle and your health.

Sample copies of RECREATION, for use in canvassing, will be mailed free.

## THE KIND THAT KILLS

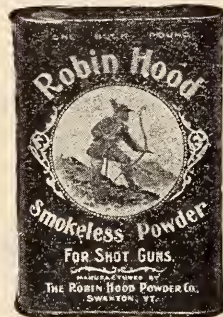

Quality  
Right

Price  
Right

# ROBIN HOOD Smokeless Powder

Loaded in  
ROBIN HOOD SHELLS

## The Robin Hood Powder Co.

Manufacturers of  
**SHOT GUN AMMUNITION**  
Swanton, Vt.

Send for Powder Facts      Mention RECREATION

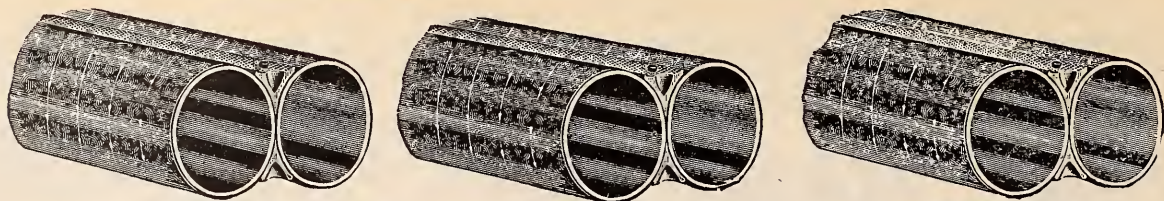

# ITHACA GUNS

TAPER  
GRACEFULLY  
TO THE MUZZLE

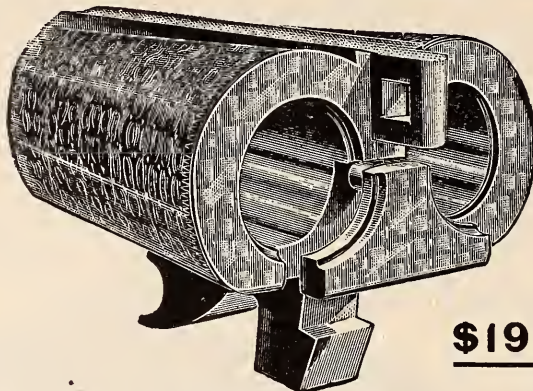

HAVE  
DOUBLE-THICK  
NITRO BREECH

**CROSS  
BOLTED**

**16 GRADES**

**\$19.50 TO \$300**

**ITHACA GUN CO., ITHACA, NEW YORK**

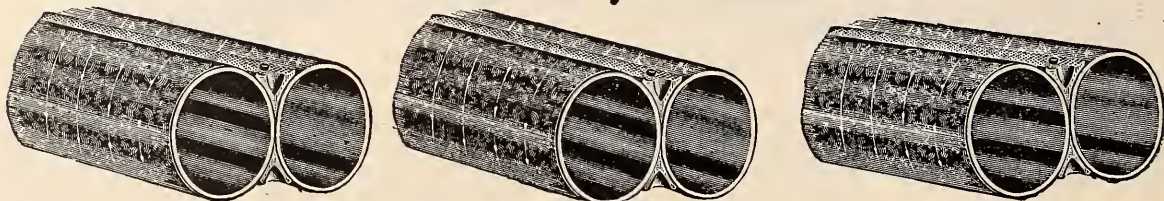

## H. & R. SINGLE SHOT GUN

*Automatic and Non-Ejecting*

The cheapest absolutely safe gun, with improvements found heretofore only in the highest priced.

**PERFECT IN MODEL  
AND CONSTRUCTION**

**SIMPLEST "TAKE  
DOWN" GUN MADE**

12, 16 and 20 gauge; barrels 28, 30 and 32 inch, plain steel and twist. Top snap; center hammer; rebounding lock.

Your dealer can supply, or we will sell to you direct. Write for Catalog.

**HARRINGTON & RICHARDSON ARMS CO.**

Dept. R, WORCESTER, MASS.

*Makers of H. & R. Revolvers*

The Name  
**DAVENPORT**

has been identified with the manufacture of

**GUNS and RIFLES**

for over

**Half a Century**



Our Specialty is

**Single-Barrel Guns**

for all purposes. Light weight  
 Guns for the use of ladies and  
 young sportsmen.

Special made Guns for trap and block  
 target shooting. Heavy weight Guns  
 for wild fowl shooting.

**and Rifles**

in 22 caliber  
 for light sporting  
 and target purposes

Every sportsman should have one of our new catalogues,  
 it describes and illustrates our COMPLETE LINE, states  
 prices and contains some interesting "Hints for the  
 Novice," which will prove valuable to all gun lovers.  
 Send postal for one. Mention Recreation.

**The W. H. Davenport Fire Arms Co.**

NORWICH, CONN.

# Winter Is Coming

## GET A PAIR OF SKATES

For yourself, your best girl, or your brother, or for some other girl's brother, or for any one you love, and who is fond of skating

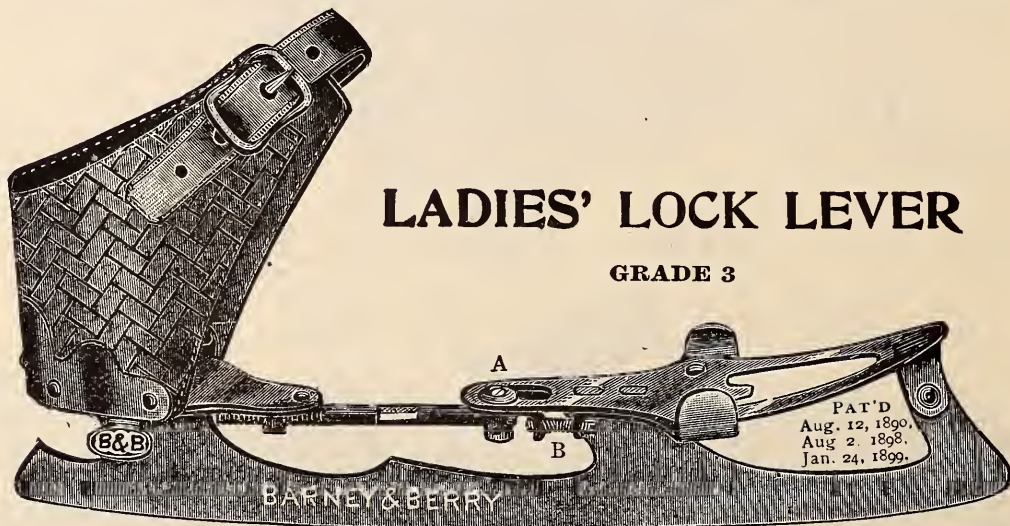

For 5 Yearly Subscriptions to **RECREATION**  
I WILL SEND YOU

A pair of Lock Lever Skates

OR

A pair of Ladies' Lock Lever Skates

Grade 3, made by Barney & Berry, Springfield, Mass.

### LOCK LEVER

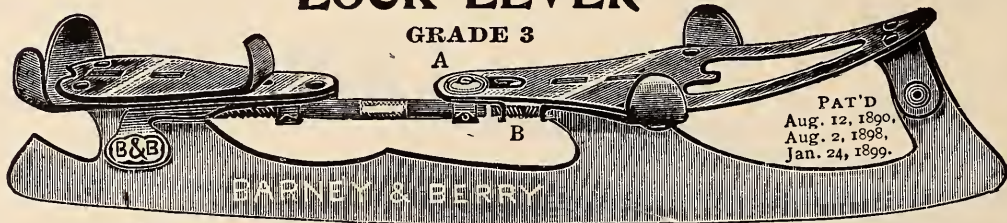

As every skater knows, these are the best skates made in the world. The winter season is approaching; and you could scarcely select a more appropriate present

FOR A MAN, OR A WOMAN,  
A BOY OR A GIRL,

than a pair of these high-grade skates. Only a limited stock on hand, and when these are gone this offer will be withdrawn.

Sample copies of **RECREATION** for use in canvassing furnished on application.

# ONE OF THE 9 "SYRACUSE" Built for Business.



COPYRIGHTED 1903

SYRACUSE ARMS CO.

This picture shows the result of a  
**SINGLE SHOT** from a **SYRACUSE**  
**16 GAUGE**

THREES OF THIS KIND ARE HARD TO BEAT

Write for a  
Syracuse  
CAT.

**SYRACUSE**  
**ARMS CO.**

**SYRACUSE, N. Y.**

Mention RECREATION.

# Rare and Valuable Books

I have for sale a few bound copies of Vol. III of RECREATION, July to December, inclusive 1895; also of Vols. IV and V. including the entire issues of 1896; Vols. VII, VIII, XII, XIII, XVI, XVII, and XVIII. All these are filled with interesting and valuable matter. The intervening volumes, are nearly all out of print, and can never be replaced at any time.

Vol. III sells at \$2.

Vols. IV and V, one book, at \$3.

All others \$2 each.

Here are a few titles that will suggest the value of these rare books, to lovers of fields and sports:

The San Juan Islands.....	Maj. John Brooke, U.S.A.
The Lord Eagle of the Storm.....	Chief Simon Pokagon.
The Cowboy and the Wheel.....	James B. Adams
Two Moose and Three Bear.....	Dr. Hamilton Vreeland
Hunting Big Game with a Camera.....	George Shiras, 3d
The Fight on Soppa Creek.....	Capt. Wheeler, U.S.A.
My Best Shot.....	Hon. W. A. Richards, ex-Gov. of Wyo.
A Prairie Pastoral.....	E. L. Kellogg
Woodcock on the Islands.....	F. W. G. Johnson
Crossing the Rockies in '61.....	Major W. H. Schieffelin
Salmon Fishing in Labrador.....	Col. Charles E. Fuller
Coursing with Greyhound.....	L. F. Bartels
A Bald-Faced Grizzly in Camp.....	M. W. Miner
A Deer Drive with Spokane Indians.....	Lieut. W. R. Abercrombie
Pheasant Shooting.....	Thomas G. Farrell
Sitting Bull's Last Medicine.....	Margaret G. Brooks
A Mountain Lion Hunt.....	Dr. Robert Meade Smith
Trouting on Clark's Fork.....	Gen. F. W. Benteen, U.S.A.
A Youthful Guide and a Prize Bighorn.....	Hon. I. N. Hibbs
The First Day of the Chicken Season.....	A. B. Cowie
Goose Shooting in Colorado.....	W. E. King
The Cowboy's Version of the Prodigal Son.....	Pony Bill
Trouting on the Thunder.....	A. D. Curtis
A Bad Grizzly.....	George W. Kellogg
My Wife's Moose.....	W. E. Bemis
How We Photographed the Wild Cat.....	Coyote Bill
Elkland.....	Ernest Seton-Thompson
Hunting Mountain Sheep in a Snowstorm.....	Capt. S. A. Lawson
Grouse in New Hampshire.....	Old Bill
Foxes in the Big Swamp.....	C. P. Franklin
On the Chilkat Pass.....	H. L. Suydam
A Rangeley Vacation.....	C. J. Halpen
Pierre's Stratagem.....	H. D. Leadbetter.

There are many other stories in the books equally interesting. You should enrich your library at once by adding to it one of each of these rare volumes.





# FIRE SALE



500 Guns At Reduced Prices

— GREAT —



## Bargains in Fine Guns

By a fire in our Warerooms on June 9th a part of our stock of Fine Guns and Sportsmen's Goods was partially damaged by water, and we shall close them out at greatly reduced prices to make quick sale.

W. C. Scott & Sons, Premier and other grades—Greener, Langs, Parkers, Remington, Ithaca, and all the leading makes.

Also other articles in Sportsmen's Goods, Athletic Goods, Bicycles, Cutlery, etc.

 Send two stamps for List of Guns, showing sizes, etc.

 The Chance of the Year 

### WILLIAM READ & SONS

107 Washington St., Boston, Mass.

ESTABLISHED 1826

## OCTOBER LIST

OF

Odd and Second-Hand

# GUNS

mailed on application

Specialty catalogue describing high-grade GUNS mailed  
on receipt of 5 cents

Mention RECREATION.

## Schoverling, Daly & Gales

302-304 BROADWAY, NEW YORK

# DIAMONDS ON CREDIT



**Diamonds on Credit** under the **LOFTIS SYSTEM** means that any person of honest intentions, no matter how far away they may live, may open a **Confidential Charge Account** for a Diamond, Watch or other valuable article of jewelry, and pay the same in a series of easy monthly payments.

**How To Do It.** Write today for our beautifully illustrated Catalogue, and from it select any article that you would like to wear or own; or, perhaps use as a gift to a loved one. We will send your selection on approval to your home, place of business or express office as you prefer. Examine it as leisurely and as carefully as you wish; then, if it is all that you anticipated, and the best value you ever saw for the money asked—pay one-fifth of the price and keep it. The balance you may send us in eight equal monthly payments.

**On the Other Hand,** if you decide not to buy, simply return the article to us at our expense. Whether you buy or not, we pay all express and other charges—you pay nothing, neither do you assume any risk or obligation whatever. We submit our goods on their merits, with absolute confidence that their quality, low price and our easy terms of payment will command your favor. We ask but one opportunity for adding your name to the largest list of pleased customers with which a Diamond house was ever honored.

**To the Cash Buyer of Diamonds,** we have a proposition to make which is thoroughly characteristic of our house. It is nothing less than a written agreement to return all that they pay for a Diamond—less ten per cent, at any time within one year. Thus, one might wear a fifty dollar Diamond for a whole year, then send it back and get \$45.00, making the cost of wearing the Diamond less than ten cents per week.

Write to-day  
for catalogue

**LOFTIS BROS. & CO.**  
Diamonds—Watches—Jewelry  
Dept. M-82 92 to 98 State St., Chicago, Ill.

**We are the Largest House**

in the Diamond business. We are also one of the oldest—Est. 1858. We refer to any bank in America—ask your local bank how we stand in the business world. They will refer to their Commercial Agency books and tell you that we stand very high, and that our representations may be accepted without question.

**Our Guarantee Certificate,** given with every Diamond, is the broadest and strongest ever issued by a responsible concern. Further, we give the broad guarantee of complete satisfaction to every purchaser. Our exchange system is the most liberal ever devised, for it permits you to return any Diamond bought of us, and get the full amount paid in exchange for other goods or a larger Diamond.

**Your Christmas Plans** will not be complete until you have looked through our Catalogue, and considered what you can do in gift-making in conjunction with the **LOFTIS SYSTEM.** The \$5.00 which you might pay for something cheap and trashy, will make the first payment on, and put you in immediate possession of a splendid Diamond or Watch. You can thus make gifts that are commensurate with, and appropriate to the circumstances, without any considerable initial outlay. There can be no more favorable time than the present for buying a Diamond. Prices are advancing steadily and a profit of 15 or 20 per cent within a year seems assured. Dealers generally agree in this prediction.

we have a proposition to make which is thoroughly characteristic of our house. It is nothing less than a written agreement to return all that they pay for a Diamond—less ten per cent, at any time within one year. Thus, one might wear a fifty dollar Diamond for a whole year, then send it back and get \$45.00, making the cost of wearing the Diamond less than ten cents per week.

# Pabst Blue Ribbon



Dear beer to brew, and  
good beer to buy—for it  
costs no more than inferior  
beers. It is the Beer  
of *Quality*—your beer.

20th CENTURY LIMITED — 20 HOUR TRAIN TO CHICAGO  
NEW YORK CENTRAL AND LAKE SHORE

# SAVAGE



**The SAVAGE** 25-35, 32-40 and 38-55 calibers are some sizes recently added to the famous 303 and 30-30 Model 1899 Hammerless Repeater. These loads are considered the standard for accuracy and will probably never be excelled for hunting and target purposes. Savage Rifles are fitted with "Special Smokeless Steel" barrels, and with a breeching mechanism *originally* constructed to withstand the enormous pressures developed by modern smokeless powder. This gives confidence to "the man behind the gun." *Catalogue G with full particulars mailed on request.*  
**SAVAGE ARMS COMPANY, UTICA, N. Y., U. S. A.**

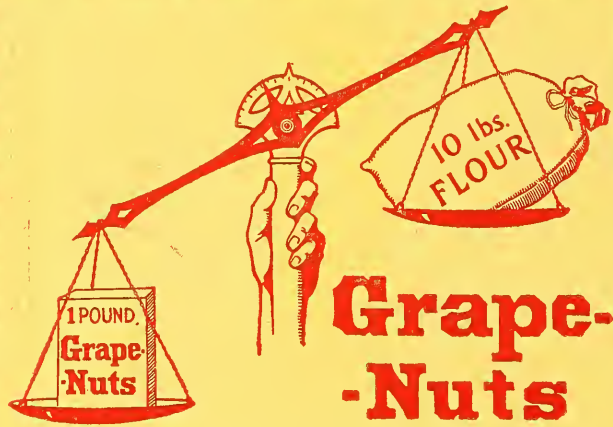

## Grape-Nuts

There is more nourishment that the body will absorb in ONE pound of GRAPE-NUTS than in TEN pounds of Meat, Wheat, Oats or Bread. This is a solid, sound, scientific truth. There's a reason.

Physicians find no stomachs too weak to digest Grape-Nuts and grow strong upon the food. And it is delicious.

## Huyler's COCOA

MAY JUSTLY BE CALLED "EXTRA SPECIAL"

PURITY, QUALITY & FLAVOR cannot be excelled and the price is within reach of all -



WHY NOT GET THE BEST?

Our only style Can. and your Grocer sells it.

# VOSE

**PIANOS** have been established over 50 YEARS. By our system of payments every family in moderate circumstances can own a VOSE piano. We take old instruments in exchange and deliver the new piano in your home free of expense. Write for catalogue D and explanations.  
**VOSE & SONS PIANO CO., 160 Boylston St., Boston, Mass.**

RECEIVED  
NOV 30 1903

VOLUME XIX,  
NUMBER 6

DECEMBER, 1903

\$1.00 A YEAR  
10c. A COPY

# RECREATION

A Clever, Exciting Story,  
By ERNEST RUSSELL

FOX HUNTING IN NEW ENGLAND;

OFFICIAL ORGAN OF THE LEAGUE OF AMERICAN SPORTSMEN



AMATEUR PHOTO BY F. C. EVANS.

SUNNING HIMSELF.

Winner of 19th Prize in RECREATION'S 7th Annual Photo Competition.

**PUBLISHED BY G. O. SHIELDS (COQUINA)**  
23 WEST 24TH ST., NEW YORK

THREE GOOD BEAVER STORIES IN THIS ISSUE,  
WITH ILLUSTRATIONS.

# THE BEST INTERNATIONAL DENTIFRICE

**I**NSURES beautiful teeth, sweet mouth, agreeable breath. Preserves while it beautifies. No powder or liquid to spill or waste in use.

CONVENIENT AND ECONOMICAL

---

Agencies in London, Paris, Berlin, Vienna, Hamburg, Ghent, Brussels, Manila, Honolulu, and City of Mexico. Sold in every city on the globe through the export jobbing houses of New York City, San Francisco and New Orleans. **25 Cents at all druggists**

**ARNICA  
TOOTH SOAP**

**C.H. STRONG & CO. - CHICAGO, U.S.A.**

# RECREATION

Copyright, December, 1902, by G. O. Shields

A Monthly Magazine Devoted to Everything the Name Implies

\$1.00 A YEAR.  
10 CENTS A COPY.

G. O. SHIELDS (COQUINA),  
Editor and Manager.

23 WEST 24TH STREET,  
NEW YORK

## CONTENTS OF THIS NUMBER

	PAGE.
I Strung Them on the Barrel of My Gun and Started for the Boat.....	FRONTISPIECE
A Goose Hunt on the Rio Grande. Illustrated.....	S. B. GILLET 413
The North Woods. Poem.....	W. M. BRYAN, M.D. 414
Duck Shooting on the St. Lawrence.....	ASHLEY D. CONGER 415
Leaves from a Trapper's Note Book. Illustrated.....	A. T. BICKFORD 417
The Architecture of a Beaver Dam.....	FRANK R. GROVER 419
Shoot'n Time. Poem.....	THOMAS JACKSON 420
Eccentricities of the Beaver.....	A. WHITEHEAD 421
Fox Hunting in New England.....	ERNEST RUSSELL 424
Harlequin Duck. Illustrated.....	ALLAN BROOKS 428
From Turkeys to Quails.....	T. H. FRAZER 429
Stice's Christmas Turkey.....	W. F. SHORT, JR. 430
Kitchi Gi-os-se Waw-be An-ne We-og.....	SIMON POKAGON 431
A White Rabbit Hunt.....	A. C. TODD 432
Winter. Poem.....	IRA SWEET 435
Antoine on Ice.....	E. W. PARKER 436
How I Killed My Boar.....	D. J. M'GILLIVRAY 437
In the Big Woods.....	H. S. BULL 439
Recollections of Burma.....	H. T. DAVIES 441
At Long Range.....	ALBERT W. DAVIES 443
A Vacation. An Idyl.....	C. C. HASKINS xxiv
From the Game Fields.....	445
Fish and Fishing.....	451
Guns and Ammunition.....	455
Natural History.....	461
The League of American Sportsmen.....	464
Forestry.....	469
Pure and Impure Foods.....	473
Publisher's Notes.....	476
Editor's Corner.....	478
Amateur Photography.....	484

Entered as Second-Class Matter at New York Post-Office, Oct, 17, 1894.

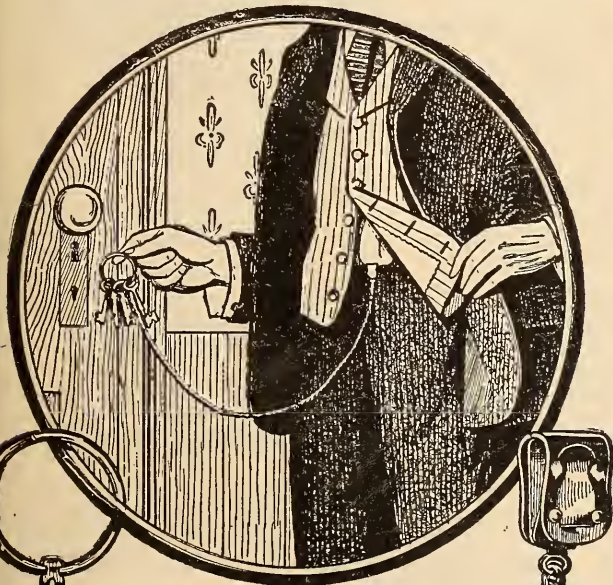

**YOU CAN'T LOSE 'EM**  
WITH  
**WASHBURNE'S PATENT IMPROVED FASTENER and KEY CHAIN**

Your keys are always with you. You cannot lay them down or leave them anywhere but in your pocket. At your dealers or sent on receipt of price—Key Rings and Chain, 25c.; Cuff Holders, 20c. a pair; Scarf Holders, 10c. Send for illustrated catalog.

AMERICAN RING CO., Dept. 44, Waterbury, Conn.

## Sore Throat

Hoarseness, Quinsy, Tonsillitis  
Laryngitis and other throat  
troubles quickly relieved  
and promptly cured  
by the use of

## Hydrozone

This scientific germicide is used and endorsed by leading physicians everywhere. It is *absolutely harmless*, yet a most powerful healing agent.

By killing the germs that cause these diseases, without injury to the tissue, Hydrozone cures the patient. Sold by Leading Druggists. If not at yours, will send bottle, prepaid, on receipt of 25 cents.

*Prof. Charles Harchand*

F-59 Prince Street, NEW YORK

# When You Get Up In the Night

## The Ever Ready Pocket Flash Light

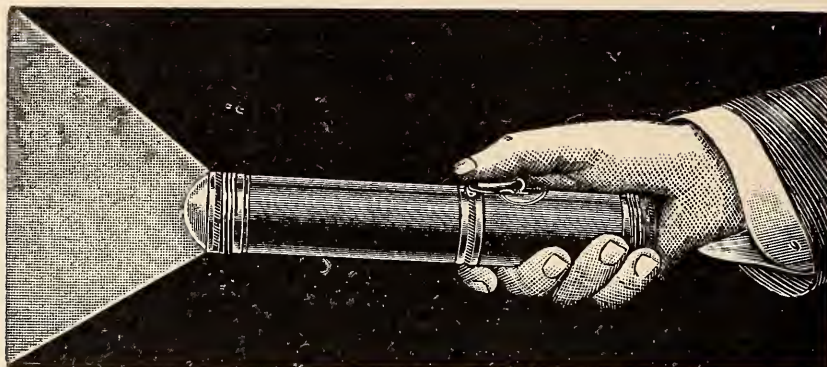

No Wires    No Chemicals    No Oil, Smoke nor Odor    No Danger

Price complete, \$3.    Extra battery (No. 10), 30 cents.

will enable you to find the match box without breaking your neck.

A luxury to every one who camps out, or who lives in the country.

## The Ever Ready House Lamp

Is a luxury for man, woman or child. It obviates all hunting for matches in the dark. It saves you from falling over the furniture when searching for the water pitcher the other door, or whatever you may seek.

Price complete, \$3.

Extra battery (No. 610) 30 cents.    Extra bulb, 50c.

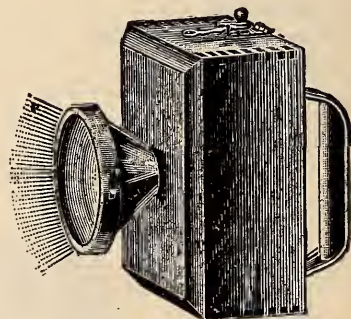

Fine Lens, Highly Polished Reflector, Finely Finished Nickel Trimmings.

## The Ever Ready Ruby Electric Lamp

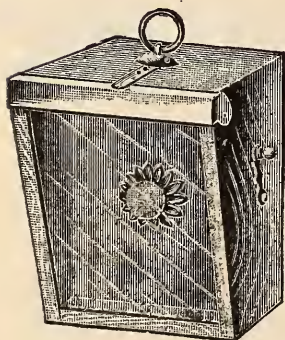

will save the eyes, the patience and the conscience of the amateur photographer who may be fortunate enough to own one.

It is provided with patent catch, so that ruby glass slide can be raised and a strong white light can be had.

One dry battery will last 3 months and costs only 30 cents.

Price of lamp complete, with one battery \$2.50.

Remit by P. O. or Express Money Order.

**B. L. SCOTT**

**23 West 24th Street,**

**NEW YORK.**

I refer, by permission, to the Editor of RECREATION.



# HIGGINS & SEITER

*For Sister,  
Wife or  
Sweetheart*

This Elegant Twelve-Inch

## **Cut Glass Vase**

(Price \$3.00—See Cut)

Would make a particularly handsome and acceptable

### *Christmas Present*

at little cost, and no trouble to the giver. Packed securely—shipped when and where ordered. In every way worthy and creditable—genuine American workmanship—a special bargain illustrating the methods of the great Present Store of the metropolis where GLASS and CHINA are always sold at least

**“ $\frac{1}{4}$  Less Than Elsewhere”**

For further particulars see our new and beautiful Lithographic Catalogue, showing actual tints and colors of some of our choicest goods; sent free, when asked for.

**Write for Catalogue No. 14-V**

Also, if specially interested in practical uses of GLASS and CHINA for the Table, and thinking of purchasing in the near future, a copy of the elegant brochure, “Serving a Dinner,” by “Oscar” of the Waldorf-Astoria, will be sent.

**W. 21st and W. 22nd St.**

(Near 6th Avenue)

*New York*

**“Buy China and Glass Right”**

**FINE CHINA,  
RICH CUT GLASS.**



# A CHRISTMAS PRESENT

FOR YOUR WIFE  
YOUR MOTHER  
YOUR SISTER  
OR YOUR BEST GIRL

For 25 Yearly Subscriptions to RECREATION

I will send you a set of

**1 DISH AND 12 TOMATO PLATES**

made by HIGGINS & SEITER, 50 W. 22d St., N. Y.

LISTED AT = = = \$19.50

AND

For 20 Yearly Subscriptions to RECREATION

I will send you a set of

**12 Watermelon Plates**

Listed at = = \$16.50

[See Illustration]

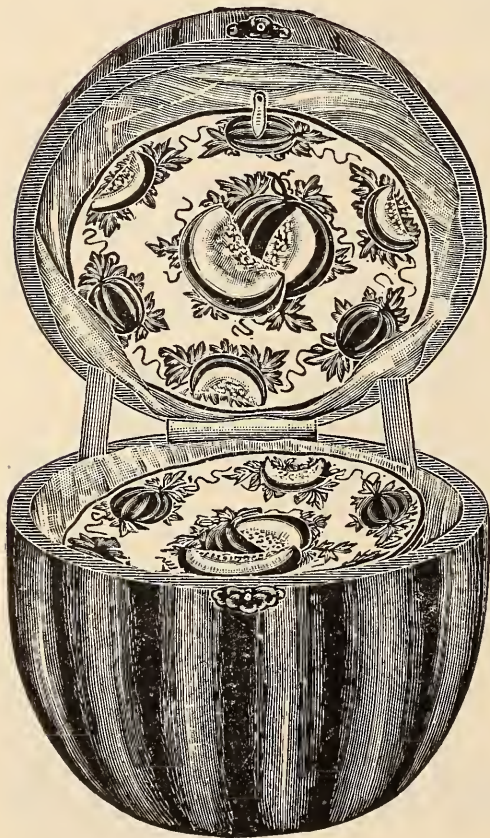

THESE are fine, thin, white china plates, beautifully hand painted, with pictures of tomatoes and tomato vines, or watermelons and watermelon vines, in natural colors, and each set of plates is enclosed in a case made in an exact imitation of a large tomato or a watermelon.

No more beautiful or appropriate present could possibly be

found for a lady than one of these sets.

You can earn one of them in a few hours, and at the same time earn the everlasting gratitude of the lady to whom you may give it.

Send for package of sample copies for use in canvassing.



## “Leading a Dog’s Life”

wouldn't be so bad if all dog owners were dog lovers. But, unfortunately, there are many people with hearts so small and minds so dull that they don't appreciate a dog's real worth. They neglect their dogs, treat them unkindly, and, if they fall sick, drive them away to cure themselves or die.

A sick dog ought to receive attention as well as a sick man. There are ways of curing dogs' diseases and saving dogs' lives, just as there are ways of treating and curing men.

The greatest remedy known for all the ailments that afflict the canine race is

## Sergeant's Condition Pills

This great remedy combines all the elements that are necessary in the treatment of nine-tenths of dog diseases. It is a tonic, builds up strength, gives appetite, makes the dog bright, active and full of vigor. No other medicine is so valuable for keeping dogs in perfect health; no other medicine has such a remarkable record of cures.

**Price, \$.50 and \$1.00, postpaid anywhere**

## Sergeant's Sure Shot

Canine worms kill many valuable dogs. Not only puppies, but grown dogs are afflicted, and often when a dog is suffering from this cause, his owner is at a loss to understand what the matter is. The more prominent symptoms of worms are nausea, colic, pains, restlessness, feverishness and abnormal appetite. Many varieties of worms infect dogs, but Sergeant's Sure Shot kills them all. It is safe, harmless and, used in conjunction with Sergeants Condition Pills, is all that a dog needs to make him well.

**Price, \$.50, postpaid anywhere**

Send 3 cents for postage and we will send you, free, our handsome Book on Dogs, and a Pedigree Blank.

Our remedies are on sale at leading drug stores and sporting goods dealers, or will be sent postpaid by us on receipt of price.

**POLK MILLER DRUG CO.** Sole Proprietors of Sergeant's Dog Remedies **RICHMOND, VA.**

# Camping Out

Camping may be pleasant, or disagreeable or dangerous. The equipment has much to do with it. Expense may be large and results unsatisfactory, or small with good results. The "KNOW-HOW"—what to take, what to leave—has most to do in insuring the comfort, pleasure and safety of an outing expedition, be it to explore untraveled mountains, or to find the north pole, or just to spend a month in the woods.

Our business is to "KNOW-HOW." Our success leads us to believe that we have learned our business.

We manufacture and sell everything for outfitting camping parties. Let us send our Catalogue R, or better still, call on us, if you contemplate "smelling burning wood" before an open tent in the shadow of the woods.

## ABERCROMBIE & FITCH

314-316 Broadway, New York

# Things Sportsmen Want

CLEANING ROD \$1.25

BROKEN SHELL EXTRACTOR ANY SIZE \$1.00

NO. 2 AXE \$2.50

NO. 1 KNIFE \$2.50

Some luxuries are really necessities. No sporting kit is complete without one or all of the items shown in this border.

What difference if you already own a knife or axe or a waterproof match safe or any of the other specialties shown?

Unless you own the BEST, unless you can feel that the knife is thoroughly dependable, the axe convenient, keen and durable, and the match safe really moisture proof, you still lack the very foundation essentials for a sportsman's outfit.

These long December evenings are the times every true sportsman loves to think of the past and plan for the future.

Be good to yourself—be good to your friend and comrade. Buy a Christmas gift of some one or more of these specialties. The investment will draw 100% interest in satisfaction.

Our complete catalog of specially designed, hand finished and tested specialties sent to any address on request.

But you can't miss the mark if you order direct from the illustrations shown in the border.

All Marble Sporting Specialties are for sale by dealers everywhere or direct from the factory, prepaid, on receipt of price.

Send right now for Catalogue A.  
It's Free.

## Marble Safety Axe Company

GLADSTONE, MICH., U. S. A.

MATCHBOX \$0.4

NO. 5 AXE \$1.50

COMPASS \$1.25

AUTOMATIC GAFF HOOK \$1.50

NO. 1 FISH KNIFE 85¢

NO. 3 FISH KNIFE \$1.00  
MARBLE'S FRONT GUN SIGHT \$1.00





*Grand Winter Cruises*  
to  
**JAMAICA**

by the  
**United Fruit Co.'s Steamship Lines**

*Jamaica*, the most beautiful of the Caribbean Islands, is but five days steamer from Boston and four from Philadelphia. Its winter climate is delightfully mild and agreeable. The vegetation is of rare luxuriance and gorgeous coloring. The scenery among the Blue Mountains is grand in the extreme. The hotels are excellent, the roads in perfection and the sea bathing in winter a luxury unknown elsewhere. CAN YOU IMAGINE A MORE DELIGHTFUL SPOT FOR A WINTER SOJOURN?

*The United Fruit Company's*

Steel, Twin-Screw, U. S. Mail Steamships

**Admiral Dewey**                      **Admiral Schley**  
**Admiral Sampson**                  **Admiral Farragut**

make weekly sailings between Boston, Philadelphia and Jamaica, affording a pleasant coastwise passage through tropic seas and genial temperatures. FARE, including meals and stateroom accommodations, \$40; round trip \$75.

Send for illustrated booklet fully describing Jamaica, its scenery, people and interesting inland tours. Free on request.

For information and booklets address

*Division Passenger Agent*

**United Fruit Company**

Long Wharf  
BOSTON, MASS.

Pier 5, North Wharves  
PHILADELPHIA, PA.

RAYMOND & WHITCOMB CO. } Tourist  
THOMAS COOK & SON,         } Agents

and

Leading Ticket Offices  
in All Large Cities

# J. M. Hanson's Clubbing Offers

LEXINGTON, KY.



Greatest Magazine Bargains Ever Offered

RECREATION - - 1 year, \$1.00 } All Three  
 REVIEW OF REVIEWS " 2.50 } One Full Year  
 Outing or World's Work may be substituted }  
 SUCCESS - - - 1 year, \$1.00 } **\$3.00**  
 Checks accepted.

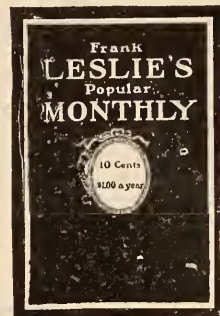

The periodicals in any club offer will be sent to one or different addresses. Join with your friends and take all.  
 The subscriptions may be new or renewals.  
 All Subscriptions are for One Full year.

	Regular Price	Our Club Price.
Recreation and Four-Track News . . . . .	\$1.50	\$1.25
Recreation, Outing and Country Life . . . . .	7.00	4.25
Recreation, Success and Harpers' Bazar . . . . .	3.00	2.00
Recreation and The Housekeeper . . . . .	1.60	1.25
Recreation, Cosmopolitan and Pearson's (or Leslie's Mo.) . . . . .	3.00	2.00
Recreation, Outing, Success and Outdoor Life . . . . .	5.00	3.50
Recreation, Success, Leslie's Monthly and Pearson's . . . . .	4.00	2.50
Recreation, Woman's Home Companion and Cosmopolitan . . . . .	3.00	2.00
Recreation, Success and World's Work (or Country Life) . . . . .	5.00	3.00
Recreation, Forest and Stream, (new Sub.) and Leslie's Mo. . . . .	6.00	4.75
Recreation, Physical Culture, Cosmopolitan and Leslie's Mo. . . . .	4.00	2.50
Recreation, House Beautiful, Outing and Success . . . . .	7.00	3.50
Recreation, Country Life in America and Cosmopolitan . . . . .	5.00	3.25

Recreation . . . 1 year, \$1.00	Our Club Price	<b>\$4.50</b>
Review of Reviews " 2.50		
Outing . . . " 3.00		
Success . . . " 1.00		

Recreation . . . 1 year, \$1.00	Our Club Price	<b>\$4.25</b>
World's Work (or Country Life) " 3.00		
Lippincott's Magazine " 2.50		

Recreation . . . 1 year, \$1.00	Our Club Price	<b>\$2.50</b>
Outdoor Life . . . " 1.00		
Cosmopolitan . . . " 1.00		
Pearson's (or Leslie's) " 1.00		

Recreation . . . 1 year, \$1.00	Our Club Price	<b>\$3.50</b>
Physical Culture " 1.00		
Success . . . " 1.00		
Outing . . . " 3.00		

Recreation . . . 1 year, \$1.00	Our Club Price	<b>\$5.25</b>
Forest and Stream (new sub.) . . . . . 4.00		
Pearson's . . . " 1.00		
Outdoor Life . . . " 1.00		

Recreation . . . 1 year, \$1.00	Our Club Price	<b>\$3.25</b>
Photo Era . . . " 2.50		
Leslie's (or Cosmopolitan) . . . " 1.00		
The Housekeeper " .60		

Recreation . . . 1 year, \$1.00	Our Club Price	<b>\$4.25</b>
Scribner's Magazine " 3.00		
Outdoor Life . . . " 1.00		

Recreation . . . 1 year, \$1.00	Our Club Price	<b>\$4.00</b>
St. Nicholas . . . " 3.00		
Leslie's (or Cosmop'n) " 1.00		

Recreation . . . 1 year, \$1.00	Our Club Price	<b>\$4.50</b>
Century Magazine " 4.00		

Recreation . . . 1 year, \$1.00	Our Club Price	<b>\$3.25</b>
Cosmop'n (or Leslie's) " 1.00		
Outing . . . " 3.00		

Ladies' Home Journal and Saturday Evening Post . . . Special Price **\$2.25**

**FREE** If you will send us three orders for any combinations you may have free as your premium a yearly subscription to Recreation, or Leslie's, Mo. or Cosmopolitan. Your own club and two other clubs make the three.

Youth's Companion (including all extra numbers and calendar for 1904) may be added for \$1.75  
 Harper's Magazine (or Weekly) \$3.35; Century, \$3.65; St. Nicholas, \$2.65;  
 Scribner's \$2.85; McClure's \$1.00; Munsey's \$1.00; Everybody's \$1.00;  
 Delineator \$1.00; American Inventor \$1.35.

**Club Raisers and Agents Wanted** to take orders for our combination offers, Liberal commission paid. Our large 44-page catalogue contains about 3,000 publications at low prices. Write for it now and see how much you can save. **IT'S FREE.**  
**GREAT PRIZE OFFER TO AGENTS.** Write for particulars.

Address **J. M. HANSON MAGAZINE AGENCY LEXINGTON, KY.**  
 120 HANSON BLOCK

# Winter Is Coming

## GET A PAIR OF SKATES

For yourself, your best girl, or your brother, or for some other girl's brother, or for any one you love, and who is fond of skating

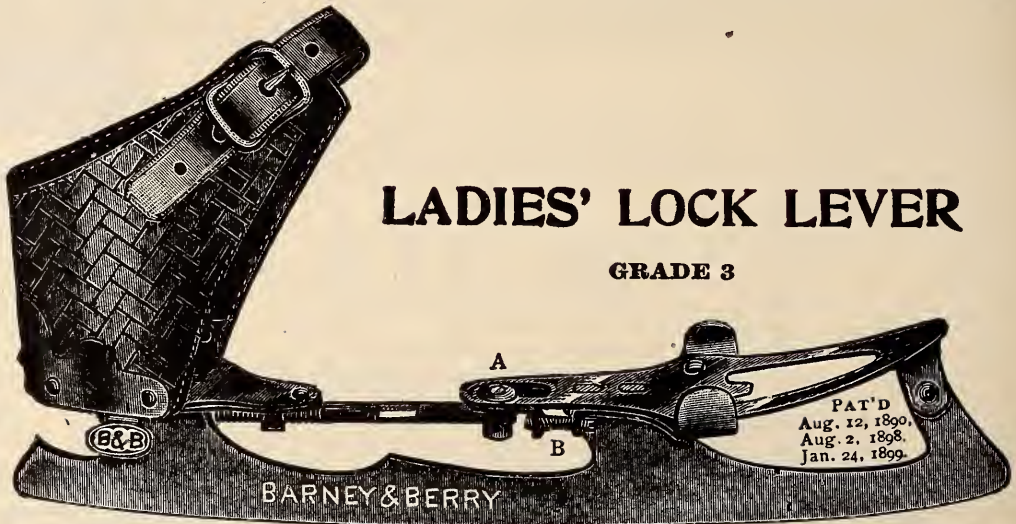

For 5 Yearly Subscriptions to **RECREATION**  
I WILL SEND YOU

A pair of Lock Lever Skates

OR

A pair of Ladies' Lock Lever Skates

Grade 3, made by Barney & Berry, Springfield, Mass.

**LOCK LEVER**

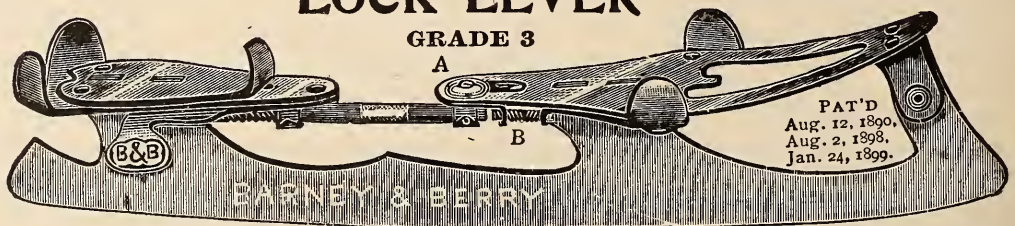

As every skater knows, these are the best skates made in the world. The winter season is approaching, and you could scarcely select a more appropriate present

FOR A MAN, OR A WOMAN,  
A BOY OR A GIRL,

than a pair of these high-grade skates. Only a limited stock on hand, and when these are gone this offer will be withdrawn.

Sample copies of **RECREATION** for use in canvassing furnished on application.





THE  
WORLD'S  
STANDARD



THEY'RE MADE TO MEASURE

# Putman Boots.

Go on like a glove *and* fit all over.

For a **Quarter of a Century** Putman Boots have been the Standard among Western Hunters, Prospectors, Ranchmen and Engineers (who demand the best) and we have learned through our personal contact with them **how** to make a perfect boot.

Putman Boots are in use in nearly every civilized country in the World. They are Genuine Hand Sewed, Water proof, Made to measure, Delivery charges prepaid, and cost no more than others. Send for Catalogue of over **30 different styles** of boots. Also **Indian Tanned Moosehide Moccasins**. We send with catalogue Order Blanks showing how to measure your foot.

We have in our files thousands of letters similar to the following.

**GENTLEMEN:**—Please send me another catalogue. We are all wearing Putman Boots and find them far superior to any other boot. I have ordered about 20 pairs for friends here during the past three years, and every pair has given perfect satisfaction, and I feel that I have done a man a favor when I have recommended your goods to him. Respectfully,

W. H. FLUKER, Gen. Mgr,  
(Columbia Mining Co.)  
Tatham, Ga.

**GENTLEMEN:**—I have just returned from a duck hunt in Colleton Co. this state, and though I tramped through the marshes for six days and a part of the nights, sinking in mud and water nearly to the tops of the shoes I got from you, my feet kept dry throughout the trip and the shoes were as soft at the wind-up as at the beginning. I can cheerfully recommend your shoes to all sportsmen. Yours respectfully,

C. F. DILL,  
Greenville, S. C.

**GENTLEMEN:**—Was fishing through the ice on the Flathead River this week standing for hours in wet snow and slush and tramping through the mountains, and I found the boots you built for me in December to be thoroughly water and snow proof, and quite warm. Yours truly,

L. R. FOGLE, Great falls, Mont.

Illustration shows  
No. 900, 14 inch  
Boot, made to measure  
and delivered  
in U. S. for

**\$7.50.**

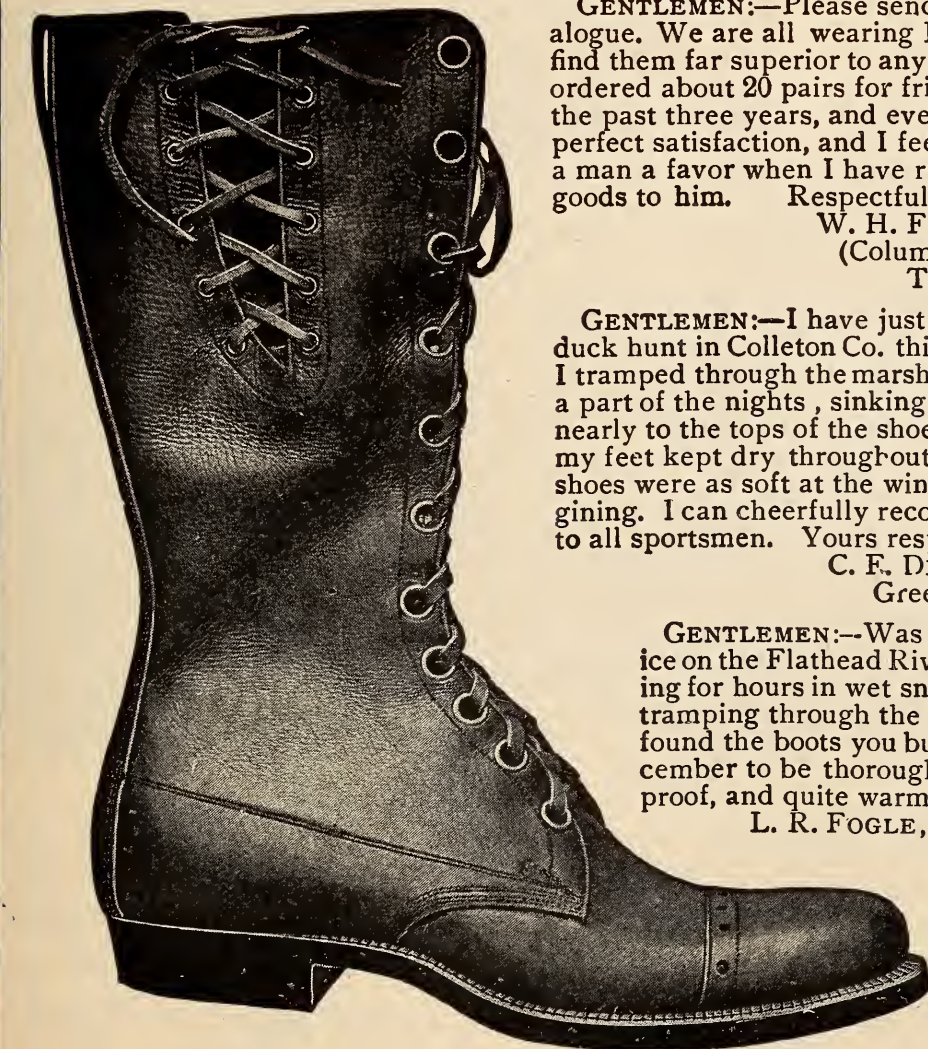

**H. J. PUTMAN & CO.,**

36 HENNEPIN  
AVE.

**Minneapolis. Minn.**



# Opportunity

Opportunity to work

Opportunity to establish a home

Opportunity to acquire a competence

Opportunity to educate your family

Opportunity for the farmer to secure fertile lands cheaply, for the merchant to reach a large tributary country, for the manufacturer to secure raw material, excellent water power, near-by markets and intelligent labor, for the laborer to establish a home and raise and educate his family in comparative luxury. All this is yours in the nine western commonwealths through which The North-Western Line passes.

## Ninety New Towns

Along recently built extensions of The North-Western Line, offer flattering business opportunities to mechanics, merchants, farmers, laborers and professional men, which are told about in a little pamphlet entitled "Opportunities for Business," sent free to any address on application.

Special low rates are made via The North-Western Line for homeseekers and settlers, concerning which any ticket agent will give full particulars on application. It will pay you to investigate.

Address Section P, Traffic Department, Chicago & North-Western Railway.

CHICAGO, ILL.



## The Wise Men

Of the Twentieth Century travel over the Lake Shore & Michigan Southern Ry.

The old gentleman in the picture is joyfully telling his friends how, detained until the last moment by business and sorely disappointed at the prospect of a Christmas away from home, he happened to learn of the fast service of the "20th CENTURY LIMITED," how he caught the train just in time, and thus after all is assured of a merry Christmas with his folks.

For information about travel over the Lake Shore address A. J. SMITH, G. P. & T. A., Cleveland, Ohio.

To travelers everywhere the Lake Shore wishes a Merry Christmas.



**"FOR 35 YEARS A STANDARD PIANO."**

# THE WING PIANO

**YOU NEED THIS BOOK** IF YOU INTEND TO BUY A PIANO. A book —not a catalogue— that gives you all the information possessed by experts. It makes the selection of a piano easy. If read carefully, it will make you a judge of tone, action, workmanship and finish; will tell you how to know good from bad. It describes the materials used; gives pictures of all the different parts, and tells how they should be made and put together. It is the only book of its kind ever published. It contains 116 large pages, and is named **"The Book of Complete Information About Pianos."** We send it free to anyone wishing to buy a piano. Write for it.

**SAVE FROM \$100 TO \$200** We make the WING PIANO and sell it ourselves. It goes direct from our factory to your home. We do not employ any agents or salesmen. When you buy the WING PIANO you pay the actual cost of construction and our small wholesale profit. This profit is small because we sell thousands of pianos yearly. Most retail stores sell no more than twelve to twenty pianos yearly, and must charge from \$100 to \$200 profit on each. They can't help it.

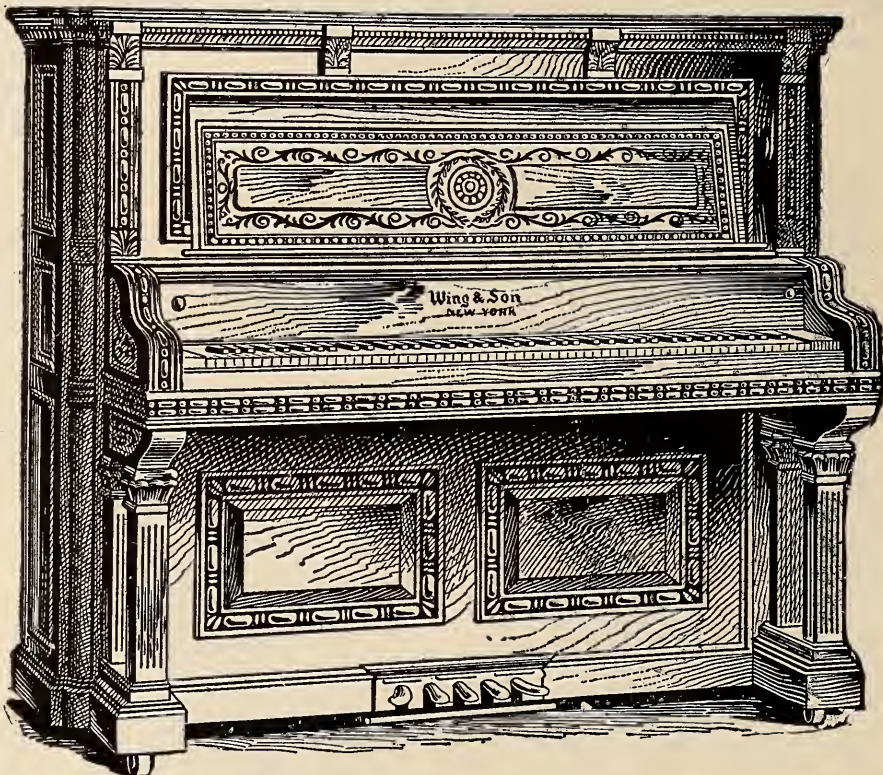

*A Wing style—45 other styles to select from.*

**SENT ON TRIAL** WE PAY FREIGHT. NO MONEY IN ADVANCE. We will send any WING PIANO to any part of the United States on trial. We pay freight in advance and do not ask for any advance payment or deposit. If the piano is not satisfactory after twenty days' trial in your home, we take it back entirely at our expense. You pay us nothing unless you keep the piano. There is absolutely no risk or expense to you.

Old instruments taken in exchange.

**EASY MONTHLY PAYMENTS.**

**INSTRUMENTAL ATTACHMENT** A special feature of the Wing Piano; it imitates perfectly the tones of the mandolin, guitar, harp, zither and banjo.

**IN 34 YEARS 33,000 PIANOS** We refer to over 33,000 satisfied purchasers in every part of the United States. WING PIANOS are guaranteed for twelve years against any defect in tone, action, workmanship or material.

**WING ORGANS** Are just as carefully made as Wing Pianos. They have a sweet, powerful, lasting tone, easy action, very handsome appearance, need no tuning. Wing Organs are sold direct from the factory, sent on trial, are sold on easy monthly payments. For catalogue and prices write to

**WING & SON,** 432 and 434 West 13th St.,  
NEW YORK.

1868—35th Year—1903.

DELIGHTFUL WATER TRIPS  
via PALATIAL STEAMSHIPS of the

# CLYDE LINE

THE ONLY DIRECT ALL  
WATER ROUTE FROM  
BOSTON AND NEW YORK  
TO CHARLESTON S.C.  
AND JACKSONVILLE  
**FLORIDA**  
WITHOUT CHANGE

THEO. G. EGER, G.M.  
WM. P. CLYDE AND CO.,  
GENERAL AGENTS  
19 STATE ST. N.Y.

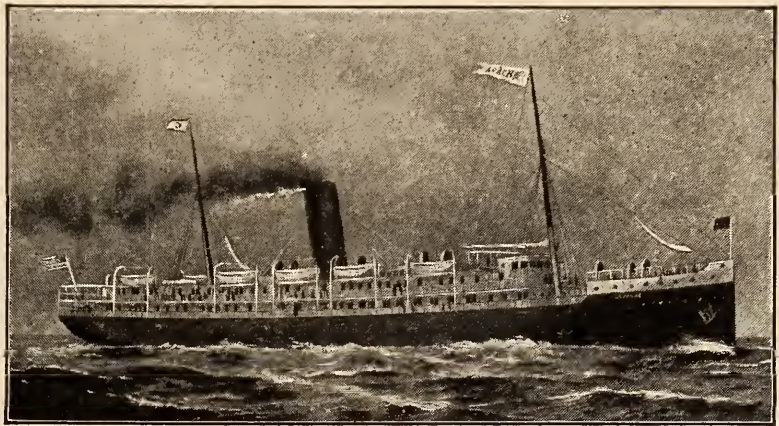

"A new 'promised land.'"

## SALT LAKE IN WINTER

In the valley of the Jordan which traverses a new promised land, sits the gem of Utah—Salt Lake City. The climate is delightful, the city is of unusual interest, and a visit is always enjoyable. It can best be reached by the

**NEW YORK CENTRAL LINES**

and their connections.

A copy of No. 5 of the "Four-Track Series," "America's Winter Resorts," will be sent free to any address, on receipt of a two cent stamp, by George H. Daniels, General Passenger Agent, New York.

## Perfect Comfort in Traveling

VIA

## OLD DOMINION LINE

TO

## Gunning Grounds

OF

Dismal Swamp, Chesapeake Bay, and James River, Virginia; West Virginia; Currituck, Albemarle and Pamlico Sounds, and Roanoke Island, North Carolina.

Sailing every week-day from Pier 26, North River, foot of Beach Street, New York, at 3 p. m.

Dogs, on chain, carried free, when accompanied by their owners.

Connections made at Norfolk and Richmond for all points South and Southwest. Through tickets and baggage checks.

H. B. WALKER, Vice-Pres. and T. M.  
J. J. BROWN, General Passenger Agent.

General Offices: 31-35 BEACH STREET, New York.

# UNCLE SAM SAYS IT'S ALL RIGHT.

Uncle Sam in the person of Ten Government Officials, has charge of every department of our distillery. During the entire process of distillation, after the whiskey is stored in barrels in our warehouses, during the seven years it remains there, from the very grain we buy to the whiskey you get, Uncle Sam is constantly on the watch to see that everything is all right. We dare not take a gallon of our own whiskey out of our own warehouse unless he says it's all right. And when he does say so, that whiskey goes direct to you, with all its original richness and flavor, carrying a **UNITED STATES REGISTERED DISTILLER'S GUARANTEE** of **PURITY** and **AGE**, and saving the dealers' big profits. That's why **HAYNER WHISKEY** is the best for medicinal purposes. That's why it is preferred for other uses. That's why we have half a million satisfied customers. That's why **YOU** should try it. Your money back if you're not satisfied.

# HAYNER WHISKEY

**1 QUART \$1.00**

**4 QUARTS \$3.20**

**WE PAY EXPRESS CHARGES IN EITHER CASE.**

Send us **\$1.00** for **ONE QUART** or **\$3.20** for **FOUR QUARTS** of **HAYNER SEVEN-YEAR-OLD RYE**, and we will pay the express charges. We ship in a plain, sealed package; no marks to even suggest contents. If you don't find it all right and better than you can buy from anybody else for double the money, ship it back to us at our expense and your money will be promptly refunded. We ship one quart on your first or trial order only. All subsequent orders must be for at least 4 quarts at 80 cents a quart. The packing and express charges are almost as much on one quart as on four and even at \$1.00 for one quart we lose money, but we want you to try it. **WE PREFER TO HAVE YOU ORDER FOUR QUARTS FOR \$3.20 RIGHT NOW FOR THEN WE WILL MAKE A LITTLE PROFIT AND YOU WILL ALSO SAVE MONEY.**

Trial orders for Ariz., Cal., Col., Idaho, Mont., Nev., N. Mex., Ore., Utah, Wash., or Wyo., must be 1 Quart for \$1.25 by **EXPRESS PREPAID**. Subsequent orders on the basis of 4 QUARTS for \$4.00 by **EXPRESS PREPAID** or 20 Quarts for \$16.00 by **FREIGHT PREPAID**.

Remit by Check, Bank Draft, Express or Money Order. It is unsafe to send currency unless you register your letter. Write our nearest office and do it **NOW**.

ESTABLISHED  
1866.

**THE HAYNER DISTILLING COMPANY,**

DISTILLERY  
TROY, OHIO.

DAYTON, OHIO. ST. LOUIS, MO., ST. PAUL, MINN., ATLANTA, GA.,



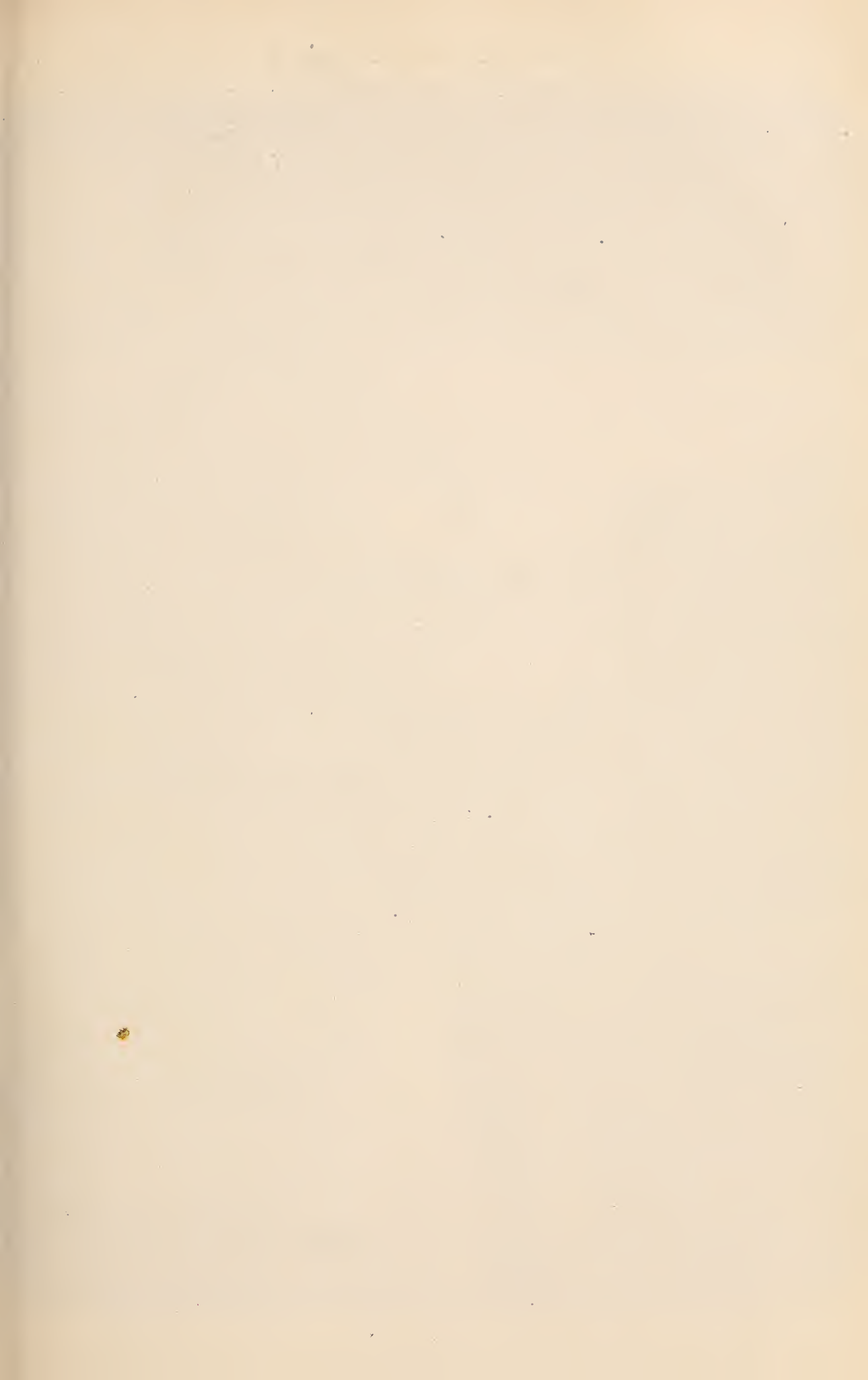



I STRUNG THEM ON THE BARREL OF MY GUN AND STARTED FOR THE BOAT.



# RECREATION

Volume XIX.

DECEMBER, 1903

Number 6.

G. O. SHIELDS, (COQUINA) Editor and Manager

## A GOOSE HUNT ON THE RIO GRANDE.

S. B. GILLETT.

Hunting geese is one thing, killing them is another. I have killed geese since I was a boy; in the marshes, on the lakes and on the rivers; but to kill them on the Rio Grande, in New Mexico, is work. Here, you office worker, if you would become a new man, rejuvenated, and would start that torpid liver to active work, come with me on a goose hunt, and if you do your part your liver will be all right.

I had been cooped up in my office 2 or 3 years, Sundays and every other day. Being told that geese were numerous on the Rio Grande, I made arrangements for a hunt. Not having hunted on the Rio Grande, the Nile of America, the river that is a mile wide and an inch deep. I procured a guide. He, like myself, had hunted always. He knew the Rio Grande; I didn't.

He told me the way to kill geese on the Rio Grande was to procure an engine headlight, fasten it on the end of a boat, and float down the river at night. Accordingly I had him get the headlight, a boat and a wagon, together with such other equipments as he thought necessary. We left Albuquerque for up the river one clear, cold afternoon in the winter of 1897. After traveling about 10 miles we reached the river above the Corrales bridge. We took with us a boy, who returned with the wagon after seeing us safe into the water.

Immediately across from us, on a sand bar—and bars are awful—sat a flock of geese. They knew they were safe, so our dropping into the river, unloading our traps and shipping them

was of no concern to them; they simply greeting us with their familiar honk. Being ready to drop down the river, we sent our wagon back to town, but I have wished from that time until now that we hadn't. We floated down and across the river. The geese never stirred. Immediately to the West of them faded the setting sun. A thicket had grown to perfection on the same side. The dog, the guide, lamp, lunches and several guns were left with the boat while I made a crawl on the geese. I used an 8-gauge muzzle loader on them and killed, or rather wounded, 3 geese. They made a line for the river and all were far apart. Then I made the "goose run," and the geese made me run, to catch them. The sand bar was covered with mud; I had on rubber boots. By the time I had caught one of the geese the other 2 were 100 yards apart and 300 away from me. I caught the second goose, but the third one was so far away that I only grabbed him as he reached the water. Maybe you think I didn't need my dog.

Speaking of dogs, I have the best on earth. You can not reach geese on the Rio Grande with a following dog. You do well to get to them alone, and you have to sneak to get to them at all. It makes me tired to hear one say "as crazy as a goose." They are wary birds. You can't catch them asleep. They are not crazy.

I tied my geese around the neck with a string, threw my gun across my shoulder, strung them on the barrel of my gun, and started for the boat. Between me and the boat lay a

slough with about one foot of water and 2 feet of mud. Midway of the slough one of the geese advised me that he was not dead. He stuck his feet in the back of my coat and began pounding me over the head with his wings in a manner that reminded me of the time when I went to a country school. He simply knocked fire out of my eyes, but I kept on across the slough. I was weak when I reached the bank. I threw my geese and gun on the ground, and sat down to wipe, as I supposed, the perspiration from my neck; but it wasn't perspiration at all, it was blood. That goose had cut my head in 3 places and I was bleeding profusely. Nothing daunted, I made for the boat.

By the time we got ready for our float down the river it was dark. Then our troubles began. The shoals, or sand bars, stood ever ready to re-

ceive us. We could not make any progress. We went about a mile in 3 hours. At last we went ashore. I had 3 guns, the 8-gauge weighing 18 pounds; 3 geese, shells galore, lunch buckets, rubber boots, overcoats and what-not, and was 9 miles from home, on the darkest night I ever saw; with a guide whose ankles had both been broken in the Adirondack mountains years before. We started to walk home, but the old man couldn't make the trip. He stopped at a Mexican's ranch. I walked home. We carried all that load on foot 3 miles. I feel tired yet. It was 12 o'clock that cold winter night when I reached home. The old man brought the boat down the river the next day. The geese weighed 15, 16 and 16½ pounds. It was enough; the work was hard, but the compensation was sufficient. In fact, I should like to repeat the trip now.

---

## THE NORTH WOODS

W. M. BRYAN, M.D.

Back in the deep, dark, silent Northern woods,

Far from the hurrying, sickly haunts of men;

Where Nature reigns, untouched by careless hand,

And time scars not the splendid scenery—  
There river, lake, and giant trees combine  
To demonstrate God's perfect handiwork.

O clouds that float above the mountain tops,  
Where lie the banks of white, eternal snow;  
O winds that wander through the pine tree boughs,

You visit ne'er a nobler land than this!

Fair realm of peace and dreams and rest,  
Where Nature holds dominion blest,  
The calm repose that thou dost keep  
Seems like a thousand years of sleep  
Of some vast sun which God's great might  
Will wake again to life and light.

The peaceful beauty of each lake,  
On whose fair breast the shadows shake,  
Must cheer the wanderer through the days  
Of winter snows or summer haze.

Arcadia, Columbialand,  
Thy somber beauty is so grand  
My soul of thee a home would make,  
My last, long spirit-rest to take.

---

First Lawyer: Does your assistant know anything about law?

Second Lawyer: Not a thing. We only keep him to draw up wills.—Exchange.

## DUCK SHOOTING ON THE ST. LAWRENCE.

ASHLEY D. CONGER.

One of the most interesting, as well as exciting modes of duck shooting, is from behind a blind. This art is acquired only by persistent practice, as may be learned from any of the experienced duck hunters on the St. Lawrence. The fall shooting lasts about 3 weeks, consisting mainly of broadbills, as they are called here, but blue-bills farther South. These birds, having been driven South by the freezing of little streams and lakes farther North, assemble in large numbers on the waters of the St. Lawrence before their final flight South, where they feed on wild rice, etc., and return again in the spring to the St. Lawrence as fat as butter.

After the broadbills leave, the whistlers make their appearance, and about the 1st of December they come in large numbers, making flocks of thousands of birds. This class remains here all winter, living in the swift waters, which do not freeze entirely over, and feeding generally on shell fish and wild rice, a rare luxury to them. This species is never seen on land and seldom on ice, but in their hatching season they build their nests in the hollow of a tree.

As usual on Friday night, Frank and I went down to the shack to spend Saturday shooting ducks. The next morning before dawn we cautiously slid our boat out over the ice, and with a store of decoys as well as grub, started for the place we had selected as best for our morning's hunt. A large ice jam had come down in the night and lodged in front of the place where we expected to set our decoys, leaving a little channel, the only water space on that side of the river.

"They'll come down through here if they will anywhere," said Frank, knowing that whistlers always avoid flying over the ice when possible. The decoy house being built out of ice cut from the edge, I slipped on my white duck suit and stepped into the blind, while Frank sorrowfully rowed far enough away not to arouse the suspicion of any game which might come within range of my trusty gun. It was light enough to discern the faint outline of the shore and before I knew it an early riser slipped into the wooden counterfeits, whistling a merry tune, soon to be silenced by a charge of No. 5's from my right barrel.

This shot roused the birds from their roosting places and up the river it looked as if a black thunder cloud were approaching. The whistling was united in one massive chorus, the sweetest music to a hunter's ear. What a sight! People say they fail to see the sport in duck shooting, in which one must sit out on the ice and freeze. Could any genuine sportsman freeze at such a sight? I actually perspired as I nervously slipped 2 No. 5's into my gun, and with my eyes on a level with the top of the decoy house, and head as still as possible, brought my gun into easy position to raise, for a whistler does not take more than 3 or 4 seconds to discover that he is fooled, and loses no time in making his exit. Two more birds swung within easy range and one reckless fellow dropped in; but I prefer wing shots, as a larger target is given. One of these dropped to my right barrel. The left only wounded the other and made the feathers fly from his broad tail. The one in the water immediately dived and was not seen again until he came up out of range. After that, I missed and wounded a number, much to the disgust of Frank, who sat in the boat chiding me as being a bad shot. This aroused me and I bagged 2 green headed drakes in one shot as they swooped over the decoys; and I kept on until I had 6 sure ones; for in the swift water one is never sure of a duck until he is safely deposited in the boat.

It was then Frank's turn to shoot, and what a bombardment he gave them! He burned all his shells and secured only 4 birds. When no birds fell at his last shot, he swore it was the gun, and that he would never shoot the cursed thing again.

At noon, the worst part of the day for a flight, I took it easy on a straw bag behind the blind, reading until I was aroused 4 times by the splash of single ducks, as they alighted among the decoys. All these were secured by cautiously turning around and shooting them as they flew out.

With 16 handsome birds we made our way back to the shack, where we enjoyed a good feast and a sound sleep. This is only one of the numerous experiences which we have had, but by far the most exciting and best of our duck shooting career as boys.

---

"I paid \$200 for this terrier."  
"Skye high, eh?"—Judge.



CHRISTMAS DAY IN A CANADIAN FOREST.

## LEAVES FROM A TRAPPER'S NOTE BOOK.

A. T. BICKFORD.

During the winter of 1902-3, my partner and I were camped in the mountains of British Columbia on the upper reaches of the Kettle river, a tributary of the Columbia. Just below our camp on the river bank, a colony of beavers had their home, so we had excellent opportunities to observe their mode of living, and to take note of their ways. In view of the interest which was taken by the readers of RECREATION in some photos of mine, illus-

and those living in lodges, or houses. When beavers are found living in holes in the bank of a river, or in washes, as they are termed by trappers, it may be taken as an indication that the original colony has been disturbed and broken up. Our beavers were living on the small poplars, or cottonwoods, growing on the slope of the bench, 40 or 50 feet above the water. The beavers had a deep path worn in the snow, where they had dragged down the saplings, seiz-



CUTTING TIMBER FOR A DAM.

AMATEUR PHOTO BY A. T. BICKFORD.

trative of "Beaver Work," which appeared in the issue of June, 1900, I again venture to place before you a more recent photo, and my experiences among these interesting animals.

This particular colony probably consisted of 4 or 5 pairs of what are termed bank beavers; that is, they lived in burrows, or holes, in the bank, running back 15 to 25 feet from the water's edge, the entrance being below the surface. As far as I can discover there is no physical difference between bank beavers

ing them between their powerful teeth, as is shown in the illustration.

In the river bed could be seen their store of food, laid up for times when the river might be frozen over, thereby holding them prisoners; the poplars being stowed underneath some sunken logs. About 5 miles from our camp was a lake comprising 100 acres of clear water, 6 to 10 feet in depth. This lake had been formed by the beavers damming a small stream, so one can imagine how the topography of a country may be altered by these little animals whose in-



MORE DAM TIMBER.

dustry has become proverbial. This dam was a double breastwork of logs, sticks and mud, the upper dam probably built after the lower one, in order to further increase the depth of water, thereby giving the beavers easier access to, and water transport for their food, which grew on the banks above.

At the head of this lake I discovered the largest specimen of a beaver lodge, or house, I have ever seen. It rose to a height of 8 feet or more above water level, and was at least 20 feet across at the surface of the lake, extending wider below. As an instance of the perseverance of the beaver I relate this anecdote:

On the banks of the Kettle river, below the lake, were living a party of placer miners, who were washing the auriferous gravel of the river bank, and were using

the water of the beaver lake for the purpose. The miners had a ditch, about  $\frac{1}{2}$  a mile in length, tapping the lake at the opposite end, the natural outlet, which the beavers had dammed. The cunning animals soon discovered the leak and persistently dammed the sluice each night, so the miners had a walk each morning of  $\frac{1}{2}$  a mile over logs and through swamp before they could start to wash for gold. This greatly annoyed them. After it had gone on for a week or 2, the miners appealed to me in their desperation to free them from their dilemma. I showed them how to set their trap, and one morning a fine large beaver was found, hoisted high and dry on a tossing pole. After that there was no more trouble with the water supply.

There is a considerable difference of opinion concerning the weight of a full grown beaver. Some trappers I have met claim they have caught beavers weighing 60 or 70 pounds, which I think is over the mark. The largest beaver I have caught, with a 50 pound flour sack, would, I should judge, weigh about 40 pounds, comparing them. A beaver that I put the tape on measured 3 feet 11 inches, from tip of nose, to end of tail, before being skinned. The tail was one foot long and 6 inches wide.

Both male and female beavers are equipped by nature with oil glands and bark bags (*castoreum*) situated at the root of the tail. The *castoreum* is used by pharmacists in compounding a medicine and by trappers as a lure for beaver and lynx, the oil glands furnishing the beaver with waterproofing for his furry coat.

About the middle of May the female gives birth to 2 to 4 young, which she suckles at her breast. Some trappers claim that all but 2 of the young of each litter are killed, but of this I have no proof.

---

Professor Wilson, of Edinburgh, wrote on the blackboard in his laboratory:

"Professor Wilson informs his students that he has this day been appointed honorary physician to the queen;" and a student added "God save the queen."—Chicago Herald.

## THE ARCHITECTURE OF A BEAVER DAM.

FRANK R. GROVER.

For several years the old beaver dams on some of the trout streams in the wildest woods of Northern Michigan, around the straits of Mackinac and Les Cheneaux islands, where I have passed many summer vacations, have been an interesting study. Last summer it was my good fortune to see a new beaver dam just receiving the finishing touches by a colony of these interesting and industrious creatures. I was not looking for beaver dams, but for brook trout. A young native, a chance acquaintance of the year before, described the "great big trout you kin ketch up by the old river dam, jest a mile or 2," and he was engaged to show me the place. A tramp of the Michigan "mile or 2" took us to a new place on Taylor's creek, a stream I had known in part for many years, and which is head waters of the Munuskong river. The usual wading of the stream and crawling through the thick brush and over fallen logs, in following the creek toward its source, then ensued. We soon reached our supposed destination, when my guide exclaimed,

"Why! the dam is gone!"

Sure enough there was the wreck of an old beaver dam that had lately been washed away. The next instant I heard the boy say,

"See, they have built a new one, and the little rascals have built it in 2 weeks. The last time I was up it wasn't here at all."

About 30 rods up the stream was the new dam, in plain sight, and it was of such interest that I soon let the trout go and spent several hours examining the beaver work. The main part of the dam was in a narrow part of the stream, where the banks were comparatively high and rocky. From the down stream side it looked much as if a pile of brush coming down stream had caught on the banks, with this exception: The brush was mostly green and freshly cut. This part of the dam was about 20 to 25 feet long and about 5 feet high. A close examination, however, disclosed that under and among this mass of brush were ingeniously placed, in all sorts of effective positions, short poplar and birch logs, freshly cut, 3 to 6 inches in diameter and 2 to 3 feet long. Not a drop of water seemed to come through the dam. At the top it had a sharp and well defined ridge like that of the roof of a house, the slopes running both up and down stream. On the upper side the brush and logs had been neatly plastered with

mud dug from the bottom of the creek, for the stream at the beginning of the slope, toward the apex of the dam, was over 10 feet deep. The depth of water below was less than 2 feet. The loss of the old dam seemed to have taught the necessity of guarding against the washing away of the new one, for near it, up stream, was a heavy pine log, partly submerged, extending across the stream in such position as to catch floating ice and driftwood.

The architects and builders had been at work the night before. On either side of the stream, and following its banks for 100 yards, was a low dam, or sort of dike, one to 2 feet high, leading to the dam proper and converging from the dam up stream like a funnel. This dike was constructed in the same manner, except that the logs were smaller and shorter, and the dike extended above the level of the stream to meet the requirements of the colony in high water. The mud and clay plastering was fresh; and that the beavers' tails had been used as trowels, which is sometimes questioned, was plainly shown by the filelike troweling, which was so regular and workmanlike that even a full fledged union mason might well have been proud of the job. While some of this work had evidently been done with the paws, the fresh troweling by the tail was unmistakable. This dam, thus constructed, made a pond of some 10 acres, in which were standing willows and birch and poplar trees; both food and building material.

Along and near the banks the many stumps of birches and poplars showed where the logs and brush for the dam had come from; also that further operations were contemplated and in progress. Here and there was a log freshly cut into many pieces, and even in length, as if some farmer had been on the ground to replenish his wood pile. The chips, too, were interesting; cut in the same manner, as if by a woodman's axe, their length varying from 2 to 4 inches, according to the size of the log. In the green bark of some of the pieces adjacent to the actual cutting, the crescent shaped tooth marks of some old patriarch of the colony were clearly defined, fully  $\frac{3}{4}$  of an inch in length. I did not succeed in seeing the foreman, the architect, or even one of the common laborers, but oily water around some of these fresh cuttings indicated that the builders had left a few

minutes before. Probably this was the day shift or the night workers putting in over time.

One or 2 observations as to some of the older dams on this stream may be of interest. I have seen fully an acre of ground, 200 to 300 yards away from the stream, where all the poplar and birch trees had been cut and carried away, leaving a clean, open space in the thick woods. How did the fallen trees get to the stream? A careful examination of the ground gave the answer. The trees stood on high ground. A slide had been constructed on

the hillside, where the logs, after the limbs had been neatly trimmed off, were carried or slid down to the level ground of the creek bottom. Here was a little canal a foot or 2 deep, leading directly to the stream, where the logs had been floating down in the same manner as the modern lumberman moves his saw logs. "Working like a beaver" has great significance. It is to be hoped the Michigan laws prohibiting the killing of beaver may be kept in force permanently, and the extermination of these wonderful animals prevented.

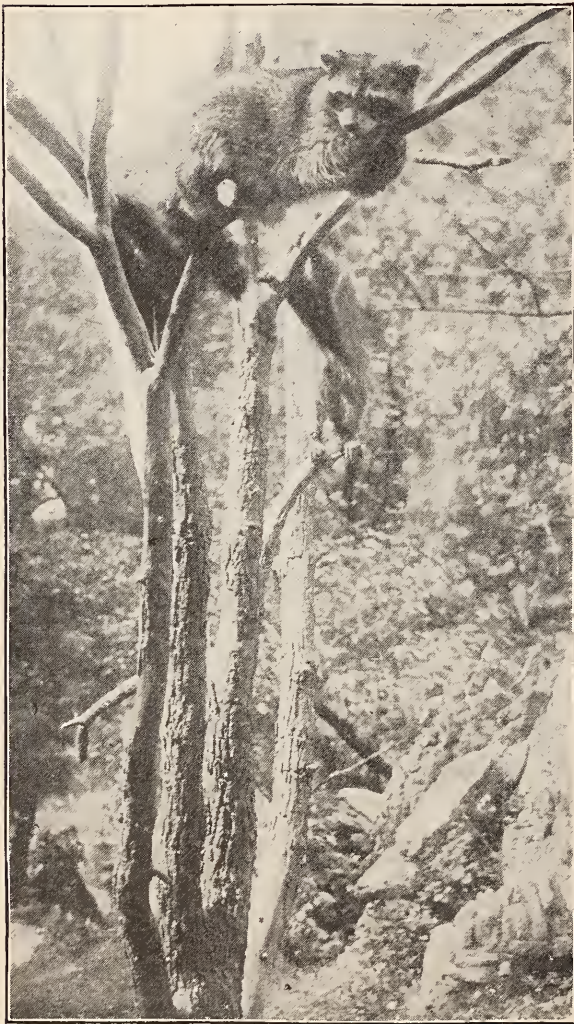

AMATEUR PHOTO BY F. C. EVANS

SUNNING HIMSELF.

Winner of 19th Prize in RECREATION'S 7th Annual Photo Competition.

### SHOOT'N' TIME.

THOMAS JACKSON.

When yer head gets full er worry,  
'N' yer appetite is slim,  
When yer business troubles kinder  
Sap yer confidence 'n' vim;

Then it's time to leave yer labors,  
'N' toward the woodland fly,  
Where the blithesome quails are callin'  
'N' the geese are honkin' high.

There you'll feel yer pulses throbbin'  
At each old familiar sound,  
'N' you'll see the rabbits bobbin'  
O'er yer happy huntin' ground.

All the day you roam the thickets,  
With yer friends on either side;  
'N' you hear faint voices callin',  
For no worry can betide.

Then at evenin', round the camp fire,  
While you talk yer pleasures o'er,  
You can hear the waves a splashin',  
As they break on slumber's shore.

'N' you hear faint voices callin',  
Callin' you to come away;  
Then in dreamland's fields you wander,  
'N' await the comin' day.

So when you are feelin' kinky,  
'N' you have to force yer food,  
Haste away to Mother Nature,  
She will always do you good.



## ECCENTRICITIES OF THE BEAVER.

A. WHITEHEAD.

In January RECREATION appeared a communication from a correspondent in this State, complaining of the scarcity of trout in the South Platte river, and saying the settlers attributed the destruction of the fish to the beaver. You express doubt as to the truth of this statement. I have since received numerous letters asking if this report about our beaver is true, and asking me to reply through RECREATION.

This I cheerfully do; partly because I wish the facts to be known about our beaver; and because nothing delights me more than to give information on scientific subjects.

For once you are wrong. The Colorado beaver does eat fish. A friend of mine, who is a naturalist, recently told me of an adventure he had, that is so remarkable I would almost fear to give it publicity were there not ample evidence of its truthfulness. He was fishing for trout in a small stream that flows past his home, in this State, when his hook was seized with such force as almost to cause him to lose his balance. Immediately the fish headed up stream; and as the angler was unable to check its rush with the light tackle he used, he was obliged to follow. My friend ran up the stream about 300 yards when he finally succeeded in landing the quarry. It proved to be a trout, as he had conjectured, but attached to its tail, and holding on with desperate energy, was a beaver of about 30 pounds weight. My friend disengaged the fish from the grasp of the beaver, and, as he found it was below 6 inches in length, the legal limit in this State, he returned it to the water. The beaver, however, he retained as a memento of his exciting adventure.

As an evidence of the truth of my friend's story he showed me a pair of gloves which he said he had made from the skin of the beaver.

In looking over my diary for notes relative to the habits of beavers, I find the following, which I take the liberty of quoting in full:

"Shortly after the late Ute uprising I, with another scientist, was camped on the headwaters of the Sjambokus river, hunting the *Giascutus giganteus*. We had met with poor success, when, as I was hunting up the river one afternoon, my attention was attracted by a colony of beavers at work building a dam. My presence had not been discovered; so, taking advantage of the cover afforded by a big boulder, I

crept as near as possible to the dam site, and taking out my field glass and note book I proceeded to investigate.

The first thing that struck me was that the beavers had provided no fishway around their dam. This was proof that they purposed eating the fish. Having impounded the water, they would allow it to freeze over so the fish could not escape to the bank. It would then be an easy matter for the beavers to move about under the ice and gorge themselves with fish.

My attention was next attracted to the method with which the beavers were conducting their work. They were apparently under the direction of a big old beaver with a gray coat and side whiskers. There were several waiters whose duty seemed to be to carry refreshments to the workers. These viands, as viewed through the glass, appeared in size and shape not unlike golf balls, and were carried to the builders by the waiters on their tails. I was puzzled and determined to investigate more closely. Accordingly I made a dash at one of them, and, although the beaver escaped, I captured his load, and, to my astonishment, found it was a codfish ball! Where the beavers got their codfish balls I am unable to say. In fact, I do not even surmise; it is my purpose merely to record the facts. Dr. Merriam, Dr. Hornaday, or Dr. Curtis, who have delved more deeply into the secrets of nature than I, could enlighten us on this point.

I have a friend in this city who is away up in science, having attained in a prominent institution of learning several degrees, and in order to get the benefit of his more mature judgment I sought him out and asked him to confirm my observations. Th's he cheerfully did.

"You are quite right," said he. "The beaver is one of the most intelligent of mammalia. He does catch fish, an animal abounding in phosphates and carbohydrides, which in turn serve to maintain his intelligence. Thus by one continuous round of alimentary assimilation is his mental superiority maintained."

No, Mr. Editor, do not doubt for a moment that our beaver eat fish. Not only so, but they show a nice discrimination in the selection of the varieties, for they are fond of brook trout and codfish.

In some parts of our State the inhabitants plant trees along the banks of the streams, so that, when hard pressed by beavers, the fish may scale the trees.

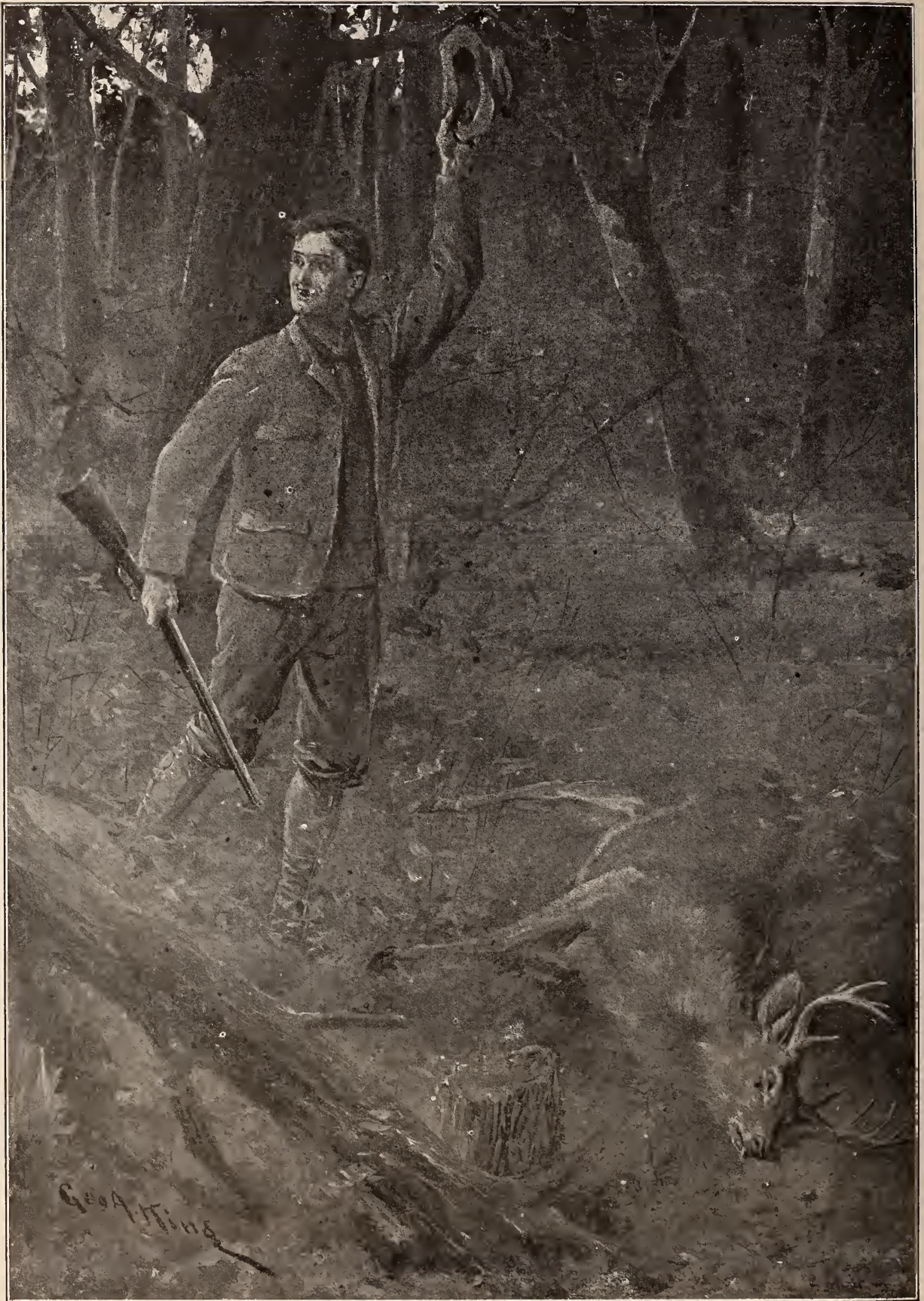

A LUCKY SHOT,  
From the Hunter's Point of View.



A LUCKY SHOT,  
From the Deer's Point of View.

## FOX HUNTING IN NEW ENGLAND.

ERNEST RUSSELL.

Down through all the years of which history brings us record, Reynard the Fox has come enveloped in clouds of condemnation. Credited even by his enemies with an inexhaustible fund of sagacity and cunning, possessed of a cheerful and devil-may-care audacity that half wins us to him, the shady side of his character is always kept in evidence and we are never allowed quite to admire even his virtues. His repeated and humiliating defeats at the hands of Brer Rabbit in the fascinating pages of Uncle Remus are sure to be welcomed by the prejudiced minds of young and old alike. He and his kind stand pariahs among our animals, relentlessly hunted by man and dog, trapped, poisoned and shot whenever opportunity offers.

Yet who among us would rejoice to witness his extermination? Who among us but feels a timid half sympathy, half respect for the very adroitness of his villainy? We place him in the category of vermin, stigmatize him murderer and thief, place bounties on his head, and still the brainy little outlaw goes slipping through the centuries with a cheerful persistence that compels admiration. Surrounded by the allied forces of his enemies, he exists in defiance of them and in practically undiminished numbers. He does not require protective legislation. He survives.

It has been my good fortune, often without injury to him, but never without the zest of true sport, to hunt the red fox in his New England haunts and in New England fashion. To our Southern and Western friends and to those in Merrie England, the methods in vogue among fox hunters in this region will appear at first glance to rob the sport of much of the charm incident to their conception of it; but we have to take conditions as we find them, and sportsmen in other sections may rest assured the fox hunters of New England feel not one whit apologetic for their chosen sport nor for the quality of it. Deprived by the natural features of the country from the thrilling spectacle of hunting on horseback, in gorgeous raiment and with large packs, there is vouchsafed to our sportsmen in copious measure that highest pleasure of ideal sport, the opportunity for individual effort, for the surmounting of real difficulties, for final triumph that taxes brain and physical stamina in many ways.

The popular conception, or rather misconception, of our sport is that of a chilled and lonely hunter standing at a barway through the tedium and discomfort of a

winter's day, listening for the baying hound and waiting for the fox to come to him. As a matter of fact your true hunter seldom waits long for the fox to come to him; he goes to the fox. Here come into play his knowledge of an interesting and diversified country. Often it is the habits and vagaries of the particular fox afoot that tax his skill, and not infrequently the chase which he must follow leads him miles away. He observes the multitude of woodland happenings that is the reward of the forest rover, he experiences that thrill which comes from close contact with Nature, and always he must have in mind his quest; he must be alert and quick to take advantage of unforeseen opportunities, keen to detect and speedy to avail himself of the little things which in hunting so often lead to victory. We trust that he has the idealizing mind, the invaluable companion of a genuine sportsman, which cheers him even under the most adverse circumstances; but often even the chronic pessimist will find the chase an inspiring one. Defeat will frequently be the lot of the cleverest hunter, but if he be of the right mold it will serve but to sharpen his ardor, increase his respect for the fox and add to a hunting experience whose memories shall console him when age steps in and bars him from his cherished days afield.

The type of fox hound most used in New England is a product of evolution. He fits into his environment as naturally as does his master and becomes a type by himself. More solidly built than his Southern brother, with shorter legs and heavier muzzle, he symbolizes endurance and determination rather than speed; while his sense of smell and the discrimination with which it is used leave little to be desired.

There are many grades of hounds here, as elsewhere, but, be it understood, I speak only of the patriarchal stock, born here, bred here, trained through generations on the local fox in its chosen home of the rugged hills, swampy lowlands and upland pastures of pastoral New England. The dashing Southern hound has been tried here, has shown his many excellent qualities, yet not being fitted to the existing conditions, he has had to give way before his deep voiced Puritan rival.

In the autumn of '99, hearing of a fox-hound, 5 years old, which had gained a more than local reputation in an out-of-the-way district of New Hampshire, I visited the locality, saw him at work, and promptly became his possessor. He was immediately

transplanted to the soil of Massachusetts, where he has since conscientiously lived up to the exacting title of "Bizness," for that is what he is, to-day, to-morrow and all the time.

The end of the first season of our co-partnership saw only 4 fresh mounds in my fox cemetery and four handsome pelts in my gun-room. We had experienced poor hunting weather, office work had kept me indoors to a great extent, and mutual understanding of dog and hunter was just commencing. The rapidity with which this hound familiarized himself with new conditions was remarkable. In half a dozen hunts he displayed a resourcefulness and aptitude for his work which made me regard my purchase with great satisfaction. He certainly could deliver the goods.

I was not wholly surprised, the following spring, to receive a handsome offer from his former owner who had become disconsolate, regretted the bargain and sought to recover the services of so valuable a servant. I had to refuse all inducements, however, in the belief that such a dog was rarely to be found or purchased, and time has justified my conclusion.

The season of 1900 was an exceptional one in many ways, resulting not only in the taking of an unprecedented number of foxes, but furnishing sensational runs, amusing incidents and story-telling material enough to last our evening gatherings for years to come.

Out of this mass of pleasant reminiscences I will select one which well illustrates the ups and downs of fox hunting, one which throws in high relief the fascinating uncertainties that give the sport its charm.

Preliminary runs for the dog on moonlit nights in September and long jaunts for his master had conditioned both for the exacting work ahead. With keen anticipation we awaited the dawn of October 1, which here marks the commencement of the tacitly understood open season on foxes. Game was plentiful and the first day's inspiring events included the death of 2 dog foxes to the 3 guns of our party. But a bare-ground hunt lacks much of the pleasure incident to snow-covered hills and we miss the long, hard drives which make our nerves tingle with excitement. We waited impatiently for the first light fall of snow.

One afternoon the opportunity unexpectedly presented itself for a short hunt. My impatience at the non-appearance of the snow led me quickly to get Biz and the gun and hike several miles from town to a territory unexamined as to the season's prospects.

We struck in at some birches in the rear of an old farm house and in 20 minutes had a fox going. He leisurely made a few in-

troductory swings about a neighboring hillock, worked a bit of swamp and, as things began to get serious, laced it out about 2 miles in a Northerly direction. I was kept on the keen jump the whole afternoon trying to get ahead of or intercept him in one of his numerous loops, but twilight found both Biz and me by the railroad trying to unravel as complete and utter a loss as ever balked hunter or puzzled dog. I finally had to call everything off and start for home in the dusk, discomfited.

I had not long to wait before there appeared the first real herald of winter in a nipping cold day which left the ground firm and hard, followed, after a slight rise in temperature, by 2 inches of snow. The storm stopped at noon and we had opportunity as though made to order. The next morning found my mare taking us out along the whitened highway at daybreak. I rejoiced at a day which left so little to be desired. I wanted all the encouragement that favorable conditions could bestow, for I well knew we were against no novice at the game.

There were old scores to settle, and I preferred to have victory or defeat rest solely upon our own endeavor.

As I stabled the mare at the barn and the old farmer came out to inquire the object of our quest, he regaled us with interesting anecdotes of Reynard's depredations, warmly expressing the hope that our attempts would result fatally for the fox.

"He ain't no use at all, that fox ain't," he declared, "'thout it's to make folks worry. Th' boys can't trap 'im an' they can't shoot 'im. He knows more'n eny on 'em, but he can't put it to no good use. I do sartinly hope you'll fetch 'im."

With the evident good will of the community to strengthen our determination, we headed for a bit of lowland where I hoped to start Reynard from a mousing expedition. I slipped the eager hound at the entrance of the brush and hurried toward the hill, which I conjectured would be his first objective point if started. I had hardly reached the hillside when a burst of music from the dog warned me the fox was afoot, with a hot trail behind him. He upset my calculations at the start by lighting out to the South, keeping to gullies and ravines, never dallying an instant. Perhaps he had recollections of the tired feet my hound had caused him earlier in the season. At any rate, he attended strictly to business, and Bizness was evidently attending strictly to him, if one could judge from the deep, staccato yelps which came back, fainter and fainter, through the intervening distance. It was a rattling drive and I made a dogged attempt to get into it.

After a hard tramp of several miles I found the dog in trouble in a large, rocky

pasture. The fox had skipped from rock to rock, along wind-swept ledges and into a wood lot, where the pine needles made the following almost impossible for the dog. The dog and I were 2 or 3 hours untangling that exasperating snarl. The sun was well over into the West when we got to our quarry, wheeling away to the North again; but our blood was up and the fox had to keep moving. Twice I nearly had him cornered, and as often he escaped. He bothered the hound considerably among the pines and on the ledges, but Biz hung to the track and would not stand for fooling. I finally got ahead of the hunt and in a period of listening marked a hot drive going toward the railway.

Anticipating a move up an old runway, I crossed the rails and took a position in a cart road which had witnessed the death of many a fox. The pursuit came straight toward me, the music clear and sharp, only to cease gradually and die out altogether. After a time I hurried down to the railway and found poor Biz tied up again. He was circling in wide sweeps as I came in sight, whining his disgust, and always ranging back to where the fox had reached the cutting. I saw at once the trouble—our game had taken to the rail. I had heard of the trick, though it was a novelty in my own experience. I thought I could beat it, but I could not. I followed the rail more than a mile before I found, in the approaching dusk, the spot where the cunning brute had left it. Occasionally he had slipped one padded foot on the snow by the side of the rail, but these instances were rare. Too late to start the hunt anew, I hustled the dog along with me to the farm, and we were soon bowling homeward, tired, outwitted a second time.

I had, at least, discovered Reynard's pet trick, the one he had often used successfully, and I decided he should not play it again if I could help it. It was a dangerous fox, this, that could lead an eager hound to where a passing train might pick him up from behind and drop his bruised and lifeless carcass over the embankment. We would settle this business, and the sooner the better.

I allowed 2 days to elapse before I made a third and well considered attempt. I reasoned that the fox's feet would be about healed from the terrific run he had so lately had. Still, he would not be keen for an all day run and I felt I could outwit him.

Again the weather was propitious as we arrived on the territory of our friend.

I am an utter novice in photography, but I felt I was likely to have a rare chance to get a photograph of a live fox on a rail, and I thought it would come near lifting the cup in a RECREATION competition. So

I borrowed a friend's 4x5 camera and banked on the result.

This time I put the dog in at a different place, knowing surely he would work the ground well over, while I grabbed gun and camera and hustled for a pile of sleepers half a mile distant on the railway embankment.

Biz worked the fox out of his home haunts in less than half an hour, and again Reynard made the mistake of trying to lose the hound in the first rush. From my snug little blind by the sleepers, I listened to the melody of a snappy drive through the brush until it passed far below me and turned toward the track. Foxy had no relish for the pace that Bizness was forcing him to and swung for a pine growth that would give him a few moments' respite. His thoughts were on his burrow, in the hillside. Soon all was quiet. Minutes flew by and I knew the jig was up as far as the hound was concerned. The time-worn, still serviceable trick was being again resorted to, for the last time, if I were any prophet.

I soon took a cautious peep around the corner of the sleepers to meet a sight I shall never forget. Quite a distance down the track, on the rail farthest from me, was the fox, headed for certain death, as nearly as I could figure it. His gait was most singular. He evidently could not negotiate the rail at his usually graceful lope and had compromised on a sort of ludicrous waddle, throwing his legs out and back like a slack wire performer. His white tipped brush flopped from side to side in the effort to maintain his equilibrium, adding a sort of rhythmic accompaniment to the exhibition. It was apparently a serious business for him. There was no stopping to listen, no glance to right or left. With head bent forward, his whole attention seemed centered on the business in hand.

I watched him as long as was prudent; then, dropping back, I grasped the camera, hurriedly placed it in position, and waited in breathless excitement for the critical moment. As he came in sight almost in front of me, I nervously pointed the little black box, pushed the button, and made a grab for the Lefever. Those sensitive, black tipped ears had heard the snap of the shutter and he was under way in almost the same instant, but he pulled the throttle of his little engine a trifle too wide open at the start. For a fractional part of a second his feet did not grip the snow clad ground, and I knew, as the gun flew to my shoulder, that his life was over. It was a fair wing shot when the crack of the smokeless came, for he was making a grand effort to escape, but the load of No. 1's that caught him made a second barrel unnecessary. Biz joined me, coming up the track at a

terrific clip, as he always does at the sound of my gun, and we were soon gloating together over our fallen quarry. Had we not earned it?

Taking the pelt of our victim and the camera, we escaped with difficulty from the clutches of the delighted farmer to seek the home fireside and talk it over.

I returned the photographic outfit to its owner with a warning as to the care of its precious contents and a request for a proof

of the picture at an early date. In 2 days it came, by mail, the artist evidently not daring to face the results of a personal encounter. It consisted of 20 square inches of plain white railway embankment with the butts of 2 maple trees starting out of the upper left corner. That was all. In shooting parlance, I had held too high, had over-shot the mark, and my name did not appear among the winners in RECREATION'S photographic competition.

PETE'S COON.

SYDNEY B. CARPENDER.

Hyar we go!  
Fus' high, den low;  
A-sizzlin' thro' de bramble;  
Des hyar Pete holler!  
Dars fun ter foller.  
O it mak my innerds scramble.

O Lawd, what fun!  
Doan' want no gun,  
Ner ornery spike-tail pinter;  
Des gimme ole Pete,  
He de bes' dorg meat  
Dis side er de place you gwine ter.

When we gits out,  
Yuh kin hyar we shout,  
Plum ter de bad place an' furder;  
An' all de coons  
Des sees three moons,  
An' jump dey skins. O murder!

Des listen ter Pete!  
Dat mean coon meat  
Fer brekfus' an' fer dinner;  
So hyar we go!  
Hunt high, hunt low,  
O Lawd! des hyar dat sinner!

Lock! Look! Dar he!  
In de ole gum tree!  
Des see dat fool dorg race!  
Des wait erwhile,  
Mister Coon'll smile  
F'um de udder side er he face.

Hyar yo' fool nigger!  
Ef yo' wuz bigger,  
I'd er th'ashed you' good an' hard;  
Des gimme dat ax!  
In erbout fo' cracks  
We'll have coon ready fer de lard.

Lickety split!  
Dats how ter hit!  
Git in dar, Pete—What dat?  
Well I'll be cussed,  
Ef dat ain't de wust!  
Nuffin' but er ole Tom cat!

First Youth—That was a great tragedy, wasn't it? Did you take your parents to see it?

Second Youth—Oh, no! They are too old for that sort of thing. They went to a farce comedy.—Life.

## HARLEQUIN DUCK.

ALLAN BROOKS.

Of all the diving ducks the harlequin is the handsomest, rivaling the wood duck in the variety of its markings. In distribution the harlequin is circumpolar, and except in the Western mountains does not occur far South of the Northern border of the United States.

In its habits the harlequin duck presents a curious anomaly, being an almost exclusively maritime duck until the breeding season, when it penetrates far inland, as-

the water is churned into milk-white foam. Here they nest in a hollow tree not far from the water, but farther North, beyond the tree limit, under a large rock or pile of driftwood.

No sooner are the young full fledged than they leave for the coast and for the rest of the year are found in flocks along the rocky shores and tidal fjords. A few stay throughout the summer on the coast but it is doubtful if these breed.



HARLEQUIN DUCK. *HISTRIONICUS HISTRIONICUS*.

ending high up the foaming mountain torrents to breed. Most of the streams in the Rockies and Cascades have a pair or 2 of these ducks breeding along their upper stretches. In the lower portions of these streams where other ducks are numerous one seldom or never sees a harlequin.

About the middle of May harlequins appear in pairs in the glacial torrents, quite at home and diving for their food, even where

The male in full plumage is easily recognized, but females and young males are soberly covered. Harlequins can be easily told from most ducks by the small and narrow bill; from the female bufflehead, which they resemble, by their larger size, absence of a white wing bar and more dusky underparts. The iris of the harlequin duck is dark hazel in both sexes. The bill in the male is plumbeous; the feet brownish olive.

---

A family in Arkansas has 3 pairs of twins. Their names by sets are Max and Climax, Kate and Duplicate, Peter and Repeater.—Albion, Iowa, Union.



## FROM TURKEYS TO QUAILS.

T. H. FRAZER.

Ten years ago a schoolmate of mine invited me home with him for a hunt during the Christmas holidays. He lived on the head waters of Green river, in Kentucky. The country was heavily timbered and rough back from the river. An occasional deer is seen there now, but we only intended to hunt quails. An old hunter told us there was a big gobbler over in the hills. The old man was much excited and we boys were soon in the same condition, so we planned a turkey hunt for the next day. The hunter and Mr. D—, my friend's father, told us of the turkey hunts they had had in the days when it was almost an every day occurrence to see wild turkeys.

We only had one breech loading shot gun and shot too light for turkeys; so we took the loads out of some of the shells and put in small buckshot, our number 12, just chambering 3. We put in 9 to the shell, and powder in proportion. It was a wicked looking charge. Then we got Mr. D's old deer gun down from its deer horn rack and cleaned it. This was a muzzle loading shot gun, double barrel, 12 guage, with 40 inch barrels; a good load for a man to carry all day.

We had breakfast before light, got into our boots, shouldered our guns, and went for the old hunter. We struck the trail a mile from his cabin on an oak ridge, followed it in the snow, and after the sun came up we found where the turkey had put up for the night in a big oak tree. We could see where his wings struck in the soft snow when he flew up to roost. The hunter showed us all this, and soon picked up the trail about 20 yards from the tree, farther down the ridge. The trail led up hill and down, and we followed it all morning. At noon the track looked as old as when we first struck it; but the hunter said the turkey was only a little way ahead of us. We found a dry place under some overhanging rocks at the foot of a bluff

where we ate our dinner. We then took up the trail again, and about 3 o'clock we came to a big bend in a ridge. As we boys were getting tired and falling behind, the hunter told us to cut across to the ridge on the other side and he would follow the trail around. He told us he was sure the turkey was still a long way ahead of us and if we went across we might get a shot at the turkey as it passed, if it had not already gone by. We were persuaded to go, as we were tired, for it is no play to follow a hunter all day through snow 6 or 8 inches deep, and carry an old gun such as I had. We went across, but could not see a trail on the ridge. We hid in the bushes and waited some time, when we heard a shot and knew the old hunter had killed that turkey. Soon he came up the ridge with the turkey over his shoulder and a sly grin on his face. He pretended he was sorry we had not gone with him, as he said he wanted one of us to kill that turkey. We were sold, as we had followed that bird all day and then did not even see him alive. The old man offered to let us carry the turkey but we declined with thanks after we had lifted him. He stood 3 feet and weighed 30 pounds. His beard was 6 inches long.

I shot a hawk that measured 3 feet from tip to tip and I thought I would have him mounted, but he was almost torn to pieces.

I loaded the gun with small shot and as we came through a stubble field we got up a big covey of quails and shot 5 of them. I got 2 at one shot and my friend made a pretty double and got another as the last ones got up.

We reached home at dark, tired and hungry, and ate nearly a whole ham and everything else in proportion. We had the satisfaction of eating that turkey Sunday, as the old man brought it over and Mrs. D— cooked it.

---

First Officer—Yes; we were marching over a plank bridge, when it gave way, and the men fell in.

Second Officer—What did you do?

First Officer—Ordered them to fall out,—  
Judge.

## STICE'S CHRISTMAS TURKEY.

Old man Stice was a veteran of the Black Hawk war, full of stories which delighted us boys and made us wish we had lived in the days when the woods were filled with game of all sorts and a boy didn't have to go far in search of adventure. Many an afternoon when the shadows began to grow long, we gathered under the old apple trees at the back of our lot and listened to some of old man Stice's stories.

"It wuz jest the day afore Christmas," the old man said, "an' I told my wife I reckoned I'd go out an' see if I couldn't git a wild turkey or maybe a deer to kinder liven up our Christmas dinner. Thar wuz a purty heavy snow on the groun', an' jest arter I set out, it begun to sleet an' rain a leetle, an' in less than no time the hull kentry wuz jest one glare of ice, an' every livin' thing thet hed any sort of shelter to go to wuz under it. I didn't ketch sight of a feather, an' thar warn't so much as a cottontail out foragin'.

"I couldn't make up my mind to go back without anythin' an' jest make our Christmas dinner on spareribs, so I tramped on all day. Once as I wuz gittin' 'crost the creek the ice give way with me an' I got a good duckin'. I didn't keer fer thet so much, though thar's no denyin' it wuz a leetle oncomfortable, but the water got into my powder horn an', of course, thet put an' end to my shootin', even if thar wuz anythin' to shoot. I hed one shot in my rifle, howsomever, an' the water didn't spile thet 'cause I held the gun up over my head.

"Well, thar wuz nothin' fer me to do but go home, disappointed and empty handed. We didn't make many presents in them

days. Thar wuz none of your cellyloid manicure sets in plush cases, or arter dinner coffe cups, cut glass fixin's, an' all thet sort of tomfoolery. The principal business of the day wuz eatin', an' some great spreads we hed. Roast pig, chicken pie, wild turkey an' ven'son, home-made hominy, punkin pie, wild honey, cider, an' other things too many to mention, an' which I won't, seein' as how I don't want to make you oneasy an' set you a-wishin' time would turn back'ards fer a spell.

"Thet year had been a kinder off one. Choleree, yawps, or somethin' or other hed got into our fowls an' they hed all died off, 'cept a decreepit ole rooster an' a few morbid hens. Consequence wuz thar warn't nothin' fer our Christmas dinner only hog an' hominy, an' as I said afore, I wuz considerable downcast over not gittin' any game.

"It wuz gittin' dark as I come through the timber which stood 'round our clearin' when, happenin' to look up, I wuz completely dumbfounded, fer thar a-roostin' on one of the lower limbs of a shellbark hick'ry wuz 19 of the biggest wild turkeys I ever see.

"Now, you know I only hed the one shot, on account of my powder bein' wet, an' I wanted to git more'n one o' them birds. I knowed as soon as I shot, thet every one o' them turkeys as warn't hit would scatter fer all parts of kingdom come, fer they warn't fairly settled fer the night, as I could tell by the way they'd moved over an' changed 'round. So I slipped aroun' till I got 3 of 'em in line, turned the old rifle loose and we had turkeys to burn, after all.

---

Villager (gazing at the ruins)—Hello!  
been a wreck here, hasn't there?

Railway Officer (hastily concealing a cut  
on his head and a broken arm)—No, sir;  
not on this line.—Exchange.

## KI-TCHI GI-OS-SE WAW-BE AN-NE-WE-OG.

(The Big Hunt of the White Men.)

SIMON POKAGON, LATE CHIEF OF THE POTTAWATTAMIES.

A remarkable hunt by the early settlers of Madina county, Ohio, took place December 24, 1818. It was described to me frequently by members of my father's band before I could speak a word of English. They had taken part in the hunt by invitation from their white neighbors, and were disgusted with the wholesale slaughter they saw committed. While attending school at Oberlin, 30 years after the hunt occurred, I often talked with old men of the dominant race, who corroborated the story.

Notice was given that all settlers of Madina county who wished to participate in the hunt should meet the day before Christmas on the borders of Hinkley township. That township, 5 miles square, was then an unbroken wilderness, though the surrounding country was fairly well settled.

The morning named found 500 settlers of all ages stationed 25 rods apart around the border lines of Hinkley. Among them was a man with long, grey hair and a frowzy beard reaching to his waist. He wore a coon skin cap, a vest of fawns' hide and buckskin trousers, and was known to his white friends as "Old Go-Lucky." He proposed to the managers of the hunt to deliver a barrel of whiskey at the spot where the hunt closed and take in payment all the wolves killed that day, thus becoming entitled to the bounty of \$5 on each scalp. His offer was at once accepted.

The commanding officer took his position at the Northwest corner of the township and his order, "Forward, march!" was passed from mouth to mouth around the 20 miles of line. The lines moved slowly inward, ringing cow bells, beating pans and blowing horns, scanning every possible cover for hidden game.

The advance continued until the hunters reached the section lines, one mile distant from the starting points, and there halted for further orders. Again the leader cried "Forward, march!" and again the 4 columns moved inward. The men were then about 8 rods apart.

Suc-see (deer) began to make their appearance, and occasionally maw-in-gwan—maw-kwa (wolves and bears) were seen. Several deer were killed trying to break through the lines. On reaching the center section of the township a second halt was

made; the hunters standing 3 rods apart and enclosing one square mile. In the middle of this section a circle  $\frac{1}{2}$  mile in diameter, had, the day before, been blazed on the trees. This circle was the slaughter pen.

The order was passed to move forward to the edge of the pen and there halt. With the advance, began a constant firing on some part of the line. Soon the hunters, then only one rod apart, stood at the edge of the circle. A few of the best and coolest hunters were sent into the pen to kill the bears and wolves, that those animals might not stampede the deer through the lines. When they neared the center of the pen, the deer, distracted with fear, attempted to break through the lines, and were shot, falling like leaves before the wind.

Then the order was given to close in. Near the middle of the tract the hunters were obliged to cross a frozen stream in a deep gully. While they were standing there, shoulder to shoulder, a bear was seen, half hidden in the brush. Several shots were fired at him, but shooting was stopped when it was found that the surrounding hunters were in more danger than the bear. Several dogs were loosed, but the bear cuffed them off and rushed on the lines. The hunters stood their ground and clubbed him with the butts of their guns. He finally broke through, but as he did so, a man threw himself on the poor brute and cut his throat, in the way a hog is killed.

At the completion of the hunt, all fire arms were discharged and stacked, fires were built and preparations made for camping for the night. When the game was brought in and counted it was found to include 390 deer, 21 bears and 17 wolves, besides numbers of lynxes, wildcats, wolverines, raccoons, etc.

Before the count was finished "Old Go-Lucky" appeared, driving a sled and astride of the barrel of whiskey. The top of the barrel was knocked in and its contents dispensed to the crowd in tin dippers. The 17 wolf skins were delivered to the old speculator, and he was the happiest man on the ground. The night was spent in drinking, feasting and singing. The Indians present afterward declared that no war or spirit dance was ever so noisy or tumultuous as that orgy.

---

Bobby—Does your pa wear tan shoes?

Jimmie—No; but he wears tan slippers.

—Exchange.

## A WHITE RABBIT HUNT.

A. C. TODD.

Two years ago last Christmas I spent a delightful week in Pike county, Pa., hunting white rabbits, and I incidentally learned there are still localities within a few hours' journey of the metropolis where wild game can be found in abundance.

Christmas morning, at 10 o'clock, I met my hunting companion at the 42d street ferry house in New York, as arranged, and after crossing the river, we boarded the train that was to carry us to our destination. We were bound for Narrowsburg, 35 miles beyond Port Jervis, on the main line. Owing to a delay it was nearly midnight when we reached the end of our journey. The next morning we took 2 of our host's best beagles and passed the day tramping through the laurel swamps and over the rocky hills near the village. We had hardly passed out of sight of the house when the baying of the dogs told us they had struck a trail. Up over the hill they went and down into the swamps beyond, while we followed as rapidly as possible. At the edge of the swamp we halted and took positions 100 feet apart, near the spot where the dogs had disappeared in the laurels. We knew that the game, after circling around the valley, would probably return on its back track. We had not long to wait. The speed at which these animals travel is marvelous. The baying of the dogs grew louder and more distinct. They were approaching rapidly and the rabbit might appear at any moment. We were fairly trembling with excitement. A bush moved on my left. My gun was pointing at it and I was about to fire when suddenly the game emerged in full sight and coolly squatted down, staring at me with its great sparkling eyes. It made a pretty picture, its white form outlined against the dark green background of laurel. It seemed a shame to spoil it and I hesitated to shoot; but the dogs were drawing near and the game was off again, covering the ground in long, rapid leaps. My sight followed it. I pulled the trigger, the animal turned over and over, and, after a few convulsive movements, lay still. The first white rabbit was mine. Before the day was over we killed 5 more, which made as heavy a load as we wished to carry home.

The next morning we were up early and found our host had planned a pleasant surprise for us. A team was standing at the door, in charge of one of the local hunters, waiting to take us back in the mountains to enjoy a day's sport. We traveled over rough roads for 10 miles before reaching the home of a relative of our host, where

we put up the horses. For 2 miles we followed our guide on foot along the brow of a low ridge and finally reached an unbroken wilderness that extended for many miles, heavily timbered with spruce and pine, crossed by sluggish streams, with now and then stretches of swamp land, covered with almost impenetrable laurel brakes. There small game of all kinds was known to be plentiful, and it was not unusual to meet a bear or a wildcat.

Tracks of white rabbits were seen in all directions. The dogs soon found a fresh trail and were off in full cry. After circling in the usual way, the game was brought back and promptly bagged and another one started. We secured 8 rabbits before noon.

Lunch over, we penetrated deeper into the swamp, in the hope of meeting larger game. Four of the dogs were off on rabbit trails which they could not be induced to abandon, but we managed to keep 2 of them with us and they proved of great use before we had gone far. I discovered a coon trail which led along the bank of a brook, and we followed it in the hope of its leading to some old dead trees where the animal could be smoked out and killed. The trail finally left the brook and led back into the timber, where it was joined by the track of another and evidently a larger animal. The trails mingled for some distance and soon we reached a spot where the snow was greatly disturbed and covered with blood, showing that a desperate conflict had taken place. A little farther on we found the half devoured remains of the coon, lying under a bush. Our guide said the animal that had followed and killed the coon was evidently a wildcat, which had hidden its prey, after making a good meal, with the intention of returning at some future time to finish it. That was just the chance we wanted.

We put the dogs on the trail and my companions pressed on, while I took up a position in a place that was known as a favorite runway for deer and other wild animals when pursued. Two hours passed and I heard no sound from the dogs or the hunters. It was growing monotonous, and I was just thinking of returning to the wagon when I heard a loud crashing in the bushes not 50 feet away. The next moment they parted and out sprang a fierce looking animal about 4 times as large as a big tomcat. I was so startled that the gun nearly dropped from my hand. Just then the baying of the hounds started through the swamp, and I knew they were following rapidly. The wildcat saw me and seemed

as much surprised as I had been. I thought of my gun, but too late. With a bound the cat had disappeared in the laurels. I started in hot pursuit. Whether I had an idea I could catch him I can't remember, but I had a wild desire to follow. I took the trail he left, through the thick bushes, where it was impossible to see a foot ahead, across brooks and ice-covered mud holes, tearing my clothes as I went. The ice over one of the mud holes I passed was particularly thin, probably because of a spring directly beneath. When I reached it I went through, into mud and water up to my neck. Grasping a branch overhead, I pulled myself out with great difficulty and made my way to shore, a most forlorn object.

The dogs soon appeared on the trail and vanished again in the bushes. A little later I could tell by their sharp, quick barks that they had the game treed a short distance farther. It mattered little to me just at that time. The day was extremely cold, and I was shivering from the effects of my unexpected plunge. Making a big bonfire, thanks to a RECREATION matchsafe, I re-

moved my outer clothes and hung them around to dry; and climbing on a huge stump as near the fire as I dared I tried to get a little warmth. In this position my friends found me, an hour later, and enjoyed a hearty laugh at my expense.

I replaced my clothing, which was nearly dry by that time, and we hastened to the spot where the dogs were still yelping. We found them making frantic endeavors to reach the wildcat, which was perched in a crotch half way up a dead pine tree, glaring down and growling defiantly. A shot from my gun brought him scrambling down the tree, when he was pounced on by the dogs and a lively fight ensued. The animal was mortally wounded, but still full of fight and would have been more than a match for the dogs. To save them from being seriously injured I put a charge of buckshot into the beast's head and ended the struggle. It was long after nightfall when we reached home. I was thankful to get into a warm room and change my clothes, which were still damp, but we voted our day a great success.



WHERE'S MY CHRISTMAS GOOSE?



WINGED OR SOUND?

## WAS THE BIRD WOUNDED?

Here is a reproduction of a photo that comes to me, and certain correspondence regarding it, which will no doubt prove interesting to many amateur photographers:

Corry, Pa.

I am sending you by this mail a negative of a ruffed grouse I caught alive and unwounded last season. He was lying under a small log which was a few inches above ground. My dog pointed him, but not until we were both within a few feet of the bird. The day was quiet and the bird evidently did not see me, as he was looking toward the dog on the opposite side of the log from me. I made a sudden grab for the grouse and caught him by the tail. My friend, Mr. E. S. Wilson, was a witness to the performance, and, having a pocket camera with him, we took 2 snaps at the only unwounded grouse we know of ever being caught by hand. When we dressed the bird at night we could find no sign of a wound or sickness about him. Wilson calls this a case of "a bird in the hand."

Yours truly,

J. W. Campbell.

On receipt of the letter and the negative I wrote Mr. Campbell as follows:

Dear Sir:

The negative of the grouse was broken when it reached my office, but fortunately that part showing the bird is intact.

I sent this to the Eastman Kodak Co. and had an enlargement made from it, 8 x 10 inches, which shows the bird well up toward life size.

It now becomes necessary to say something that I dislike to have to say. The picture shows that the bird's tail had been pulled out, that one wing was broken, and there is an indication of a shot wound in its breast. I certainly have no desire to question your statement that the bird had not been wounded, but should like further information from you before publishing the picture.

Kindly let me hear from you again,  
greatly obliging,  
Yours truly,  
G. O. Shields.

New Castle, Pa.

Dear Sir: The facts in above case were as I gave them to you. I caught the bird by the tail and the feathers pulled out in the effort. Mr. Elmer Wilson, of Corry, and his family had the bird for their dinner next day. They said they found no wounds. I have no interest in lying about it, as you seem to imply. If the wing was broken I did not know it.

Yours truly,

J. W. Campbell,  
Pastor First Methodist Church.

Comment is unnecessary. Here are a few questions, however, which will no doubt occur to every sportsman, and especially such as have undertaken to photograph live wild birds or animals.

Would a wild ruffed grouse, caught in the woods, sit on a branch of a tree, as this bird did, and let a man stand within a few feet of him to take his picture, if able to fly?

Would he let one of his wings hang down, as shown in this picture, if the wing was not broken?

If the wing was broken, could 2 men handle the bird, set it up on a branch of a tree, and photograph it without finding the wound.

Would one of these men take the bird home, dress it, and eat it, without finding out that it had been wounded?

Could he, under the circumstances, conscientiously state to his reverend friend that he found no wound on the bird?

Would his reverend friend send the picture to an editor and write "We took 2 snaps at the only unwounded grouse we know of ever being caught by hand," if that reverend gentleman were as careful of the truth as he should be?—EDITOR.

---

## WINTER.

IRA SWEET.

The wind sings a dirge on the mountain,  
Lies frozen the river below,  
While the leaves that fell in the autumn  
Are buried deep under the snow.

The birds are long gone to the tropics,  
The flowers are awaiting the spring,  
The grouse in the birches are budding,  
While merrily reigns the ice king.

The quails, our plump friends of October,  
Now fearlessly visit the barn,  
And feed with the pigeons and sparrows,  
These true autocrats of the farm.

The rods laid away in their cases,  
The gun's lying snug in the rack;  
While the range on the low lying meadow  
Rings no more to the rifle's sharp crack.

The sportsmen now read RECREATION  
And patiently wait for the day,  
When the game hog, that curse of the na-  
tion,  
In the dust will be mouldering away.

## ANTOINE ON ICE.

E. W. PARKER.

Ah'll was leeve in good many plas in mah life, but if dere's a better plas for de ice business dan good ole Canada Ah never seen it, bah gosh! S'pose you gon out you shack 3, 4 minutes, you sure fin' ice hang on de end you nose. He cover up de brook an' de reever an' w'en you not need heem de mos' you ant able get notin' else. Bimeby w'en you want heem, he's mak' hees bow an' not stop for sheck han's.

But de Canuk got plentee fun all de tam wit' de ice, de boy an' de gal an' de ole peep, too. De hockey match mak' plentee fun, 'nough so he lak better stay dere dan gon to school. Las week mah leetle boy say to me,

"Paw, come on skatin' wit' me, we have boss bully tam."

Ah lak for mak' it happy dat leetle chap, so Ah say, "Yas, Ah'll go."

W'en Ah was leetle boy mahse'f Ah gat good deal sport on mah skate. Mah fadder own fine plas for skate, one ole swamp pon' 'bout 4 acres beeg an' quarter mile long, plentee room dere for mek practise. Dere was plentee log an' some bush an' stomp wit' ice all roun'. We mak' hide an' coop an' have bully tam, an' of'en we so much engage we ant re'mber gon school till we feel heem time for gon fin' w'ere he's leave dat lonch pail.

Mah modder mak' de birt'day feas' w'at tam Ah'll got 16 year ole, and all de yo'ng folk we gon for skate. Dere's one gal he try for spark me an' he's ron for catch me on hees skate. He's boss good gal on ice, but he's hugly as dev' an' Ah'll not like heem a leetle bit. W'en he's mak' ron for catch me Ah'll mak' dodge, but he's ver' 'termine' an' grab mah coat tail an tear heem right off mah back. He's try many tam since dat to get de res' of Antoine but he 'an't do it, bah gosh!

So w'en Ah'll tol' mah leetle boy Ah'm gon skate wit' heem it mek me re'mbler Ah use be leetle boy mahse'f. W'en we got on dat plas it look ver' small; no log dere, no stomp, no not'in' on'y leetle patch ice jus' so beg 'nough for 2 rabbits play leap-frawg. But dere was some pretty gal an' some plentee boy an' dey have nace tam. Dey gon turn roun' raght an' lef' an' gon backwards an' mek de gran scoot. Den mah boy he's pull it mah coat an' say,

"Come, fadder, come an' skate," an' Ah'll say, "Ahm gon show dose peep' someting dey ant 'spec,' prob'ly."

But de skate w'at he use it now he's not good for not'ing. Ah'll use have pair dat beat heem all. He's leetle ting wit' heel strap 'roun' de instep an' some ring on bese side for tie heem wit' string roun' you ankle. De boy he's come roun' for help tie dose newfangle 'rangement. Den Ahm proceed geet on mah feets, an' Ah look over de frawg pon' an' balance mahse'f an' feel jus' same Ah was 30 year 'go.

W'en Ahm gon skate mah feet, one of it, he's turn off on de raight han' an', bah gosh, he's keep go; de odder he's turn on de lef' an' me Ah ant stop heem. Some trouble boun' rise on such 'casion, nobody ant help dat, an' dere was beeg noise lak w'en de storeman tear off de calico. Ah must do somet'ing, so me Ah sit down, an' don' wait for fin' chair either. Ah'm never seen de ice so col, an' Ah'm not want geet up too. Ah feel 'uf Ah'll ant wort much, me. So Ah'm slide softle to de shore an' up in de bush, an' de boy an' de gal dey laugh lak de dev'.

Den Ah'll tol mah leetle boy ron home an' mak' hees modder send mah new breeches raght off, for Ah's bleegeed to gon on town meetin' to cas' mah vote, prob'ly.

---

Barnes—"When I was young my mother always used to sing me to sleep."

Shedd—"Yes, women are good at that sort of thing; but it takes the father's voice to wake a fellow in the morning."—Boston Transcript.



## HOW I KILLED MY BOAR.

D. J. M'GILLIVRAY.

It was high noon of a Sunday in the winter of '95 when our little hunting party pulled up at Johnston's ranch on the Nueces river, Texas, on the way from San Antonio to Corpus Christi. We had been on the road since long before sun-up, our last camp having been at old Fort Merrill. We were making the trip on foot, in good old infantry fashion, accompanied by a pony drawing a 2-wheeled cart, containing our camping outfit.

While cooking dinner at our midday stop we were visited by men from the ranch, who evinced great curiosity about our rig, but more particularly regarding my Krag-Jorgensen rifle, the first they had seen. The weapon was then new, even to the army. When they found we had stopped to lunch only, they tried hard to persuade us to remain in that neighborhood. Buck Cates, a typical plainsman, dressed in picturesque *chaparejos*, said to us:

"You fellers don't want better huntin' than ther' is 'round here. We've right smart deer an' turkey, millions of Mexican and Bob White quails, and some wicked *javelinas*."

Noticing my perhaps satiric smile at the last mentioned game, he added:

"Oh, they ain't like them tame critters 'round San-tone. These fellers fight when hard pushed. Why, only last week one of them ripped my pony so bad I had to shoot him as well as the hog."

This interested us, and we decided to lay over that day at least and have a boar hunt. After a social nip from the demi-john our visitors departed, saying they would return in an hour with saddle horses for us. Hardly had we finished our meal when down the road came the 3 cowboys, all mounted, and each leading a spare horse.

When they drew rein I confessed that I felt rather timid about hunting on horseback, never having ridden much on account of my 200-weight. I said I preferred, if it did not make any difference, to go on foot. Buck again brought his power of persuasion to bear and wound up by introducing me to Kate. Kate was a gentle looking black mare, about 12 years old. As I stroked her nose she put her head against my breast as if to say, "Trust me." At last I consented, on the further assurance from Buck that she was like a rocking chair to ride. We rode down a ranch road about 2 miles, and drew rein while well in a thick chaparral.

"Mac," said Buck, turning to me, "ride along until I signal you to stop. Bill, you

follow, and stop 'bout 150 yards in rear of him, and the rest of you space out in the same way. The plan is to beat through this bush to the left of the road and with our line we ought to root out some porkers. Go ahead!"

I rode for perhaps half a mile, occasionally looking over my shoulder for Buck's signal. I shortly received it, and immediately halted. Indicating the direction by a sweep of his arm, Buck gave another signal and all entered the bush.

There my troubles began. Kate soon showed signs of nervousness, walking fast and leaving me to dodge as best I could the thorny branches of the mesquite. Often a branch would catch me full in the face or entangle the rifle slung across my back, almost nauseating me. Kate became more and more excited. I was on the verge of quitting when, with a snort, she broke into a furious gallop. Vainly I tried to check her, but on she flew, while the branches tore my face and clothes. She heeded not my pitiful "Whoa, Kate!" Instead, she seemed to go all the faster. In sheer desperation I threw myself forward with both arms around her neck and hung on for dear life. I could feel the blood trickling down my face, back and legs, and was becoming faint, when Kate pulled up in a little clearing as suddenly as she had started.

I dismounted, or, rather, fell from the saddle. When I rose to my feet my next scare came. There, with his back against a tree, stood a *javelina*; his little eyes blazing, bristles standing, and snapping his tusks after the fashion of his species. Mechanically I unslung my Krag and, taking the best aim that my blood-blinded eyes would permit, fired. Good luck guided the bullet and the brute dropped dead without a quiver.

While congratulating myself on my narrow escape from serious injury, the remainder of the party rode up. They had heard my crashing ride through the bush and my shot, and were an astonished looking group.

"Well, young feller," drawled Buck, "yer fooled me 'bout your ridin' and it's your turn to laugh; 'though yer don't look much like a broncho buster. Anyway, there isn't a man at the ranch that could chase a boar and kill him in better style. It is just like you army fellers; always got somethin' up yer sleeve." All of which caused me to feel well satisfied with myself and indefinitely postponed the explanation I was about to make. My companions, Newman

and Ambrose, shared the cowpuncher's belief, so the deception was complete. After we skinned the boar it was suggested that I go back to camp, have my scratches fixed up, and get some clothes on. Really I was in anything but presentable trim, even for that sparsely settled country.

I did not ride Kate back; I walked, leading her by the bridle. She was perfectly docile and looked a picture of equine gentleness. Arriving at camp, the old Mexican whom we had left in charge was nearly scared into a fit by my bloody and tattered appearance. About dark the party returned with 2 more skins and a buck. Over our toddy that night the boys often referred in words of praise to my riding. Buck mentioned that old man Johnston, when alive, always used that mare to hunt hogs

with, but of late nobody rode her except the women folks. Not once, however, did they associate this fact with the success I achieved.

Next morning we bade our friends good-by and continued our journey. Buck's last words to me were, "Don't tell them fellers down in San Patricio 'bout the way you fooled me, 'cause they'd never stop kiddin' me at the next roundup."

But the story was told at many a camp fire of the 18th infantry in Texas and in the Philippines, where Newman and I indulged in a hunting trip after different game. Yet murder will out; and when the boys of Johnston's ranch read this they will know how much of my reputation as a fearless rider I owe to Kate.

---

## THE FISHER.

ANONYMOUS.

The pehan, or fisher, as it is commonly called, is seldom seen, even where abundant because of its nocturnal habits. Its home is in the depth of the forest or along the sides of wooded valleys, far from civilization. In form it somewhat resembles the skunk, but its size is that of a large do-

its fur is handsome and of considerable value. In color it is a rich brown for the most part, with a patch between the shoulders of yellowish grey hairs tipped with black.

For its size, the fisher is an extremely strong and vicious animal. Caught in a trap it becomes the incarnation of fury. If given time it will amputate the imprisoned leg and escape. Such is its tenacity of life and insensibility to pain that it is as likely as not to return in a few days to the same trap and repeat its experience.

In spite of its popular name, it is doubtful if the fisher ever catches fish.

---

"We're glad to welcome you into our family, Mr. Newmann," said Mrs. Starvem. "Our boarders almost invariably get fat."

"Yes," replied the new boarder, who was not, however, new to boarding; "I've noticed the same in most boarding houses. It's cheaper than meat, isn't it?"—Philadelphia Press.

---

Poor old Miss Maden came near getting herself in trouble last night. She started, according to her usual habit, to look under her bed—

Yes, yes. Well?

Well, her bed at the time happened to be an upper berth in a sleeping car.—Philadelphia Public Ledger.



ANONYMOUS.

### LOOKING FOR TROUBLE.

mestic cat. It preys on hares, grouse and other small animals and birds. Its keen scent will trace a grouse to where it lies hidden under the falling snow.

The fisher is much sought by trappers, as

## IN THE BIG WOODS.

H. S. BULL.

About 35 years ago, when I was a tenderfoot, I went North with an old friend for my first deer hunt. We drove North 2 days and at our destination we found comfortable quarters, as the place was kept by an acquaintance of my friend who made us heartily welcome.

The next morning we were up at peep o' day and away. After going about 2 miles I took my watch on a ridge between 2 swamps. I was armed with a 16 bore muzzle loading double shot gun, loaded with buckshot, and a Colt's Navy revolver using powder and ball in the cylinder.

About 3 o'clock in the afternoon I heard a dog yelp over in the swamp. I looked up the ridge and saw something coming my way. It was a deer, and about 3 or 4 rods behind was another deer. I have often wondered how I knew enough to stand perfectly still. When the leader got opposite me I fired and immediately brought my gun on the other deer. To my surprise he never changed his gait but came right on. I gave him the other barrel and knocked him down in his tracks. I looked around for the first deer but could not see anything of him. Something was coming down the ridge, which proved to be a large yellow dog. I walked down to where my last deer lay, and to my surprise there lay the first one also, only a short distance away. I cut their throats, and had just got out my powder flask to reload when I noticed the old dog's nose in the air, sniffing. Looking up the ridge I saw another deer coming.

I could not load my gun and the idea struck me to use my revolver, but what about the dog? I must hold him down somehow, so the deer would come close enough for me to shoot him with my revolver. I took the revolver out of my belt, piled on the old dog's back, got one hand on his nose and awaited developments. The next thing I knew I was going one way and the dog the other. He threw me so I rolled over 2 or 3 times on the snow. I jumped up and there was the deer, on the circle. Raising the revolver I fired. The deer jumped in the air and did some tall kicking. Instead of firing at him again I set the old dog on him. I thought I had hit the deer and that the dog would kill him. The deer jumped a large pine log and the dog could not get over, so he came back to laugh at me.

I loaded my gun, marked the experience down as lesson No. 1 and was watching

for more deer, when the owner of the dog appeared.

"Did you see anything of them deer that came out here?" he asked.

"I did,"

"Did you kill one?"

I replied,

"I have 2 down and another wing-broke."

"Why don't you holler?" he asked. "Have ye been over to see what ye done?"

"No," I replied, "I hit him and isn't that all you have to do to kill them?"

"I guess you never shot any deer afore," he replied.

We went over to where I had pulled on the last deer and found hair and blood on the snow. We followed along a few jumps, when the old fellow said,

"Let me see that there revolver."

I handed it to him and after looking it over he said,

"She's a daisy. She has put a hole clean through that there deer. Don't ye see the blood squirting out each side of his track. I reckon you have hit him sure and we will find him in the morning."

Which we did, about 30 rods away.

The next day I went out with another party, including an old hunter of that locality who was to start the deer for us. It was a cold morning and there was a crust on the snow. I watched a long time and was becoming chilled when I heard the old hunter on the track. After a while I heard something jumping on the light snow crust and presently I saw Mr. Deer. He had a set of large antlers that looked like a brush heap coming my way. The woods being quite open I had a good look at him. He loped along a short distance, stopped, looked back and listened to the noise following him. His curiosity seemed to be aroused. He was not satisfied with the way things were going. He was not coming down my ridge, as expected, but was on the next one, which made a long shot for me.

When he was nearly opposite me I raised my rifle and it went off in the air! I had forgotten the hair trigger!

I jumped behind a stump and began loading as fast as I knew how. Then I stepped out again and there was the deer about opposite me. I fired again and missed him. Getting behind my stump I loaded the old rifle, stepped out again and caught a glimpse of the deer jumping behind a bush between him and me. There he stopped. I knew it was my last chance and

fired at the center of the bush. There was a blue streak for 2 or 3 jumps and he was gone. I made a few remarks, loaded the gun and started down to where the deer had crossed. The old hunter came up and wanted to know who had been shooting. I replied that I had done the shooting and had missed the deer, but had had the satisfaction of making him run like mad at the last shot.

"Have you looked?" he asked.

"No," I replied, "he is gone and let him go."

"Young feller," said the hunter, "we almost always take a look around and especially when they run the way you said he did. Where was that?"

I pointed out the place to him, he went up the trail and called for me to come. I remember, falling several times but I got there after a while. The old gentleman watched developments, for he knew he had a greenhorn, and he wanted to see what I would do.

The first thing I saw was hair and blood all over the snow. The old man stood back and I asked questions. Following along, he said,

"Look here! He is weak, for his hind legs have dragged over that little log, I

don't think he can go any farther than that ridge over yonder."

Glancing in that direction I saw the deer lying down in the snow and replied,

"There he is."

"Yes," the old man said, "what a mark that is," for the deer had raised his head to look at us. "Can't you put a ball between his eyes?"

I fired and down went the deer's head. The old man muttered,

"I'll be durned if you haint put it in the very spot!" which turned out to be true.

I discovered when I got home that I had been shooting 3 drams of rifle powder out of the old rifle, for we had forgotten to change our powder flasks.

I shall never forget my first experience in pulling a large deer out of the woods. We had to draw him about 2 miles and I thought it the hardest work I had ever done; but I learned later, in some of my hunts, that it is a much harder job when there is no snow on the ground.

I have often thought of what a string of luck was mine. It has followed me through my deer hunting. Perhaps my being a good shot had something to do with it. I have never had what is known as buck fever, but after all is over I nearly always lose my hunting knife after dressing a deer.

### FREAK HORNS.

I send you herewith print of a rare antler of a Virginia deer; 2 perfect symmetrical horns from one burr. I found this double antler fixed over the door of a lumber camp on the Franconia branch, in New Hampshire, last August. The antler was found by a teamster who gave it to a cook at the camp. Being a lover of hunting and natural history, I saw at once its rarity. I never saw nor read of any other like it though I have seen hundreds of antlers.

O. F. Neubert, Lawrence, Mass.

Actor—Did you see my "Cæsar"?

Friend—Oh, yes.

Actor—What part of it did you like best?

Friend—The part where you get stabbed.

—Exchange.



AMATEUR PHOTO BY O. F. NEUBERT

## RECOLLECTIONS OF BURMA.

H. T. DAVIES.

In December, 1899, I was assisting Mr. Ewing in the topographical survey of the Government Forest Reserves along the Yoma mountains, and was posted near the head waters of the Pegu river, called there the Tamini Chaung. In those forests there were no roads and the paths were just wide enough for single file. When we took the field after the heavy monsoons the party sailed to Burma, and each assistant set out with his native sub-surveyors and coolies toward the reserves. The first day, a march of 16 miles, we passed through the cultivated lands, and the second day we reached the scrub jungle where the native villagers are more scattered. There we found jungle fowl, and the gee, or barking deer. This deer stands about 26 or 28 inches high, and has 2 curious folds of skin down the face, from which it is sometimes called rib-faced deer. It is bright red in color, the creases being dark brown, while the chest, under parts and under the tail are white. The horns are small and are elevated on bony pedicles which are covered with hair. Each horn consists of one beam and one tine which springs from just above the pedicle. In place of horns the female has 2 small knobs. The male has 2 tusks in the upper jaw, which protrude outside the lips, and dogs bringing them to bay are often badly cut. When the gee suspects danger he keeps up an incessant hoarse bark. I have shot bucks with horns that measured  $6\frac{1}{2}$  inches from the pedicle, but I believe the record head measures  $7\frac{1}{2}$  inches. When I went out especially for gee I took my target 32 caliber, but have sometimes shot a buck with No. 2 shot in a 12 bore gun, at 20 yards.

When surveying the forests each assistant takes a separate reserve, and never sees a white face for 8 to 10 months.

We marched through scrub bamboo and gurgeon forest to the foot hills. There the bamboo clumps grow more frequent and the trees are larger. Silver lined pheasants are met for the first time, and as they scurry away you may get a shot if you are quick.

I had pitched camp, and near by were the tents of my native sub-surveyors. The hum of voices came from the coolie tents where they had just finished the evening meal and were talking of the coming sea-

son, when suddenly a terrible outcry arose.

"Sahib, Sahib, Bagh ayah." (Sir, Sir, a tiger has come.) I siezed my .577 and rushed out in time to see a shadowy form glide away into the darkness, and from out the bamboo, came the weird, indescribable roar of the baffled tiger. No one who has not heard that terrible coughing roar, away in the wilderness of trees, with only a thin wall of cloth between himself and the dreadful man-eating scourge, can realize what terror it strikes into the heart of the poor coolie.

The roars continued at intervals, now here, now there, but never a sight of the tiger could I get. One by one the coolies dropped asleep, and, waiting alone, the shadows seemed to shape themselves into the dreaded creeping form. Again and again I raised my rifle only to lower it as a second glance revealed a log or cut bush that had been removed from the cleared ground. I must have fallen asleep, for I have no recollection of the fire dying out, when suddenly the chill night air awoke me. All was still except when the night breeze stirred the teak leaves or a sleeper breathed heavily. A night bird called just then and startled me into complete wakefulness. Should I call one of my men to stir the fire or should I do it myself? I had decided to do the latter, and was about to rise, when my eyes lit on a shadow that seemed to move. I gazed intently, and from the darkness gleamed 2 yellow green balls of fire. The loneliness sent a shiver through me, and as I now recall the utter stillness that reigned in that lonely midnight hour, I can see myself raising the heavy double barrel and aiming as best I could. I brought the white handkerchief I had wrapped around the muzzle of my rifle to bear between the shining eyes. The report and the roar that followed woke the camp, and all was confusion. The fires were alight again, and, taking torches, we approached the spot, as nearly as I could judge, where I had seen the tiger's eyes. A close search revealed splashes of blood. We could do nothing that night, but on following the traces the next morning we found, a quarter of a mile away, the body of a young male tiger. As he lay he measured 9 feet 2 inches and his skin is one of the finest I ever bagged.

---

Teacher—Johnny, what is the equator?  
Johnny—An imaginary lion running  
around the earth.—The Little Chronicle.

## FOUR NEBRASKA BUTCHERS.

Nebraska seems to produce more game butchers to the square inch than any other State in the Union, and she will probably continue to hold that distinction until the present crop of butchers shall die out.

buried in a common grave in the potters' field of Beatrice, and a stone effigy of this pile of ducks erected over them. Then the children and the grandchildren of these butchers could point to the graves and say,



George Lowe, H. T. Harper, G. W. Maurer, Louis Lang, Beatrice, Neb.

Meantime, her game will probably all have been destroyed and the next generation of Nebraskans will have to be content with shooting clay birds.

When these 4 men die, they should be

“Here lie the mortal remains of 4 of the men who are to blame for the desolate condition of our prairies.”

Lowe's number in the game hog pen is 911, Harper's 912, Maurer's 913, Lang's 914.

---

Patsy: Mom, won't yer gimme me candy, now?

Mrs. Casey: Didn't Oi tell ye Oi would n't give ye anny at all if ye didn't kape still?

Yes'm, but——

Well, the longer ye kape still the sooner ye'll get it.—Philadelphia Press.

## AT LONG RANGE.

ALBERT W. DAVIES.

I spent the winter of '98-9 in the mountains of Northern Wyoming. It was unusually severe. The snow fell almost daily for 3 months, and the piercing winds came over the divide and swept down the sides of the mountains, gathering it into drifts 6 to 20 feet deep. In summer this section of the West is a garden spot of Nature, with its wooded hills and variety of vegetation, but in winter the outlook is desolate, indeed.

I had come from the home ranch in New York City the year before, in search of health. Six months later I was followed for the same reason by a chum. We decided to take up homestead claims and become ranchmen, stockmen, or whatever offered. During the summer we had been employed at a gold working 12 miles above Dubois, on the road to Yellowstone park, and had visited a pretty little valley through which ran Hunter's creek, a tributary of Upper Wind river. This latter stream runs at the foot of the Wind River mountains, which flank the Shoshone Indian reservation on the West. It is a swift and dangerous mountain stream in the spring, but an angler's paradise in summer. When gold sluicing ended in October we made a 100 mile trip to Lander, and made homestead filings at the Land Office for 320 acres in the valley mentioned. We then loaded a 4 horse team with winter provisions and providing ourselves with the implements to build a mansion, we returned to our *demesne*. The valley nestled at the foot of a high ridge, the Eastern slope of which was heavily wooded, so with little labor we built a 24 x 16 log cabin on the bank of the creek and prepared for a long winter. We had sent East for 2 of the latest rifles and a large supply of ammunition. Game is abundant in Wyoming and we had to depend on our skill as hunters for our winter's meat. We had a cheerful little home and as the wind and snow swept around the corners of the cabin and hurled themselves against the door we would throw a big stick of wood on the fire and settle down for a quiet smoke. We had taken the precaution to have skis made and had become proficient in the use of them, being able to take almost any steep hillside safely. We made frequent expeditions in search of game to try our skill, being strictly tenderfeet in using a rifle, but found that the elks and deer had not yet come down from the mountains. By November, however, when the snow was getting deep and we were sick of fried bacon, we discovered

the broad trail of a band of elks that had fed on Elk ridge hill near. The following day we started out with rifles and snowshoes, our hopes and nerves being at a high tension. We searched the Eastern slope of the ridge without success, and having reached the top prepared to hunt the other side. As the snow does not lie deep on that slope, owing to the wind having a clean sweep, we left our skis on the top of the ridge. There were a few scattering pines and plenty of large rocks and boulders on that side, obstructing a full view but affording good skulking places. We had gone but a few yards when Fred drew me down behind a boulder saying breathlessly he had seen a band of elk half way down the slope. This was a cheering announcement, but we were instantly seized with buck fever and for a few moments stared each other helplessly in the face. After the shaking had ceased and the grip on our rifles had relaxed, I cautiously peeped over the top of the boulder, and there, 600 yards below us, was a sight to quicken the pulse. Seven magnificent elk were quietly feeding. We held a whispered consultation as to how to get nearer them. A sure shot at that distance was hardly possible, even with 30-30's. The wind blew toward us so we crawled toward the game slowly and succeeded in getting 150 yards nearer, when, to our utter dismay, a big bull, evidently stationed as lookout, and which we had not seen before, saw us and gave the danger signal. Instantly they rounded together in a bunch, waiting for one to take the lead; then made tracks for safety. Hardly knowing what to do under the circumstances, we commenced to fire into the band, thinking the noise would buffalo them so as to turn them in our direction. It had almost the desired effect, for they stopped short in their wild rush and stood frightened, not knowing which way to run. This gave me an opportunity, and dropping on one knee I drew a fine sight on the head of a big fellow, and as the shot rang out he dropped. In a fraction of a second the rest of the band were making tremendous bounds slanting up the ridge. As they passed us Fred took a long chance shot at the nearest animal. The shot told and the elk stumbled and fell, but as the others headed down the side again, it got up and disappeared over the top of the ridge in the direction of the cabin, dropping big splashes of blood at every leap. Knowing it was badly hurt and would not travel far, we went down to where my game had

fallen and found him to be a 3 year old bull, majestic even in death. A plum center hole between the horns told the story and after a laborious half hour's work we had him dressed. Flagging him with a handkerchief and some empty shells, against coyotes, we took up the trail of Fred's elk. He went straight down the Eastern slope, but on seeing the cabin had doubled back into the timber and was probably there. At that point I broke a snowshoe, so suggested that Fred follow and finish the elk while I should go in and prepare supper. The old boy was worn out, however, with the chase and excitement, so we exchanged shoes and I again took up the crimson trail.

Going a short distance in the timber I suddenly saw a big brown body disappear over a small eminence and then knew it would not be long before there would be something doing between Sir Elk and me. In 10 minutes I came up to him. He was down and unable to rise, though he made frantic efforts to do so. He seemed broken in body but not in spirit, for an angry shaking of his huge antlers and a threaten-

ing expression in his big brown eyes, warned me that were he able to get up I would be safer in a tree. I pitied him, and though I hate to hit a fellow when he's down, I sent a bullet into his breast. The proud head sank lower and lower until it rested on the snow, and his sufferings were over. Fred had shot off his right hind leg at the second joint. The animal had traveled a mile on 3 legs. He was an old timer and bore scars of many a battle.

When I got to the cabin the frying pan was hot and it was not long before some juicy elk steaks were sizzling merrily in the hot grease and our supper of steak and hot biscuits was ready. We were proud of the achievement of killing an elk at 475 yards, and wounding another on a dead run at 250 yards.

We had lots of exciting sport that winter, hunting elk, deer, mountain lions and lynxes, but that first day's sport was the best. When spring arrived we went down to civilization again, thoroughly satisfied with the winter spent in the snow 125 miles from a railroad.

---

## SADIE.

SARA B. BUTLER.

A preacher's daughter, Sadie was,  
A model little lady;  
No naughty word was ever known  
To soil the lips of Sadie.

A Christmas tree stood tall and straight,  
With seven dolls around it,  
And Sadie with a little shriek  
Had just that minute found it.

She viewed the babies one by one,  
With loving pats and kisses,  
And when her darlings next she sees,  
Not one of them she misses.

In meantime mamma did a thing—  
A wise thing mamma thought it—  
She kidnapped just one baby sweet,  
And thought no more about it.

She reasoned, seven dolls at once,  
Too many for wee Sadie;  
The one she pilfered from the lot  
Would do for next year's baby.

Well, Sadie, when next Christmas came,  
Was wonderfully delighted,  
For Santa Claus had come again  
With dollies, which she sighted.

She uttered sweetest words of praise,  
For ev'ry single youngster,  
Till coming to the last year's child  
She viewed it o'er with wonder.

Then, hard she scratched her curly head,  
As if from doubt to free it.  
"I've seen that face before," she said,  
"Where the devil did I see it?"

---

Society Girl (to class in the slums):  
Then, children, I can expect you all at my  
home, 22,401 Fifth avenue, for a little par-  
ty next Saturday? Don't forget the num-  
ber of the house, 22,401 Fifth avenue.

Little Slumlet: Front or rear, teacher?  
—Exchange.



## FROM THE GAME FIELDS.

The man who quits when he gets enough, with plenty of game still in sight, is a real sportsman.

### SHALL INDIANS AND TRAPPERS BE RESTRAINED?

Here is copy of correspondence which explains itself.

Hon. James Smart,  
Deputy Minister of the Interior,  
Ottawa, Ont.

Dear Sir:

I have recently returned from a long trip in Alberta and British Columbia, during which I made a careful study of the wild animals native to that region, and of the conditions under which they are being so rapidly exterminated. A year ago last spring I made a trip in the Selkirk mountains, where I also devoted a great deal of attention to the same subject.

I understand that you are the executive officer in charge of the game in Canada, and I beg to call your attention to certain abuses that prevail, especially in the Northwest. I have not a copy of your game laws at hand, but am told you have laws prohibiting the killing and selling of game by the Indians; yet I learn on good authority that the Stony Indians and the Crees, especially, are persistently killing off the wild sheep, goats, moose and deer in the Northwest and selling the heads and skins. In my travels on and about the Continental Divide, I saw many Indian camps where large numbers of these animals had been killed, and about which their bones are now scattered.

I am told that T. C. Wilson, whose present headquarters are, I think, at Field, B. C., bought over 50 mountain sheep heads from the Stony Indians last fall and winter. He had 22 of these heads exhibited in a store and offered for sale at Field when I was there in June last. In July, when I visited the upper Saskatchewan region, Wilson had a trading post at Kootenai plains, on that river, where large numbers of the Stony Indians were then camped and were hunting throughout the surrounding country. Wilson was supplying these people with food and ammunition in exchange for game heads and skins, which he in turn sells to tourists and others.

Two men whom I met on the upper Saskatchewan had been trapping there during the past winter. I saw 3 of their bear traps, each of which was baited with the entire carcass of a goat, which had evidently been killed in the winter or early spring. All this was in close season.

I saw in the Spokane lake country another trapper, named M. M. Fry, who lives at Bonner's Ferry, Idaho, who, to my

certain knowledge, was killing every living thing he could find in that country to bait his traps with. He boasted to us of having smuggled into British Columbia certain dutiable goods, and chuckled over having been smart enough to outwit the customs officers. He killed 4 goats near our camp, some of which he used to bait his bear traps; and this in close season. When we remonstrated with him, he said he recognized no law prohibiting him from killing any wild animal he might find, at any time or place. He was camped within a few yards of us, and one day in May he brought in a female beaver which he caught in a trap, and from which he took 3 unborn young. This was after the legal season for trapping beaver; and, in fact, I am under the impression that you have a law prohibiting the taking of beaver at any time in British Columbia. This man Fry has trapped in that country each successive spring for 3 years past, and says he intends to return there next season.

Mr. W. W. Wright, of Spokane, Wash., whom I know personally, and who was in that country with me in 1902, was there again last spring. He went to New Denver and lodged with the officers there a complaint against Fry. He reported the case to the police officer, or marshal, of the town, to the justice of the peace, and to the Government agent. These men's names are, respectively: J. T. Black, C. S. Rashdall and A. McInnes.

These officers refused, however, to take action against Fry, offering first one excuse and then another. The policeman, whose duty I understand it was to go after Fry, was evidently too lazy to go, as Fry was camped 22 miles from the town, up in the mountains. The officer's excuse was that Fry had taken out a miner's license and that it entitled him to kill such animals as he might need for food. Mr. Wright explained that Fry was not eating these animals, and that at least one of the goats he killed had remained where it fell until it rotted, because Fry did not need it for food, or for bear bait. Wright explained that Fry was killing fishducks, porcupines and other harmless animals and birds which are not edible, and because he did not need many of them for bait, they rotted and were not used in any way. The policeman said,

"If this were in the open hunting season, and Fry were up there hunting without a license, I would go after him at once."

Mr. Wright replied,

"Then it is only necessary for a man to

come in here and hunt in close season, without any legal permission, in order that he may slaughter any number of animals without molestation."

I have no personal interest in the game existing in Canada, as I do not expect ever to kill any of it. On my tour during the past summer, I camped within 2 miles of a goat lick, which was being used every day and night by probably 100 goats, and it would have been easy to have killed 50 of them if I had been so disposed, but I did not kill one. I camped 2 days within 2 miles of several bands of mountain sheep and could easily have killed a dozen of them if I had wished; yet I did not kill one of them, though we were living on bacon at the time, and would have relished some fresh meat. My interest in the preservation of Canadian game is simply that of broad humanity. I do not wish to see these animals exterminated on either side of the international border. I trust you may see fit to take vigorous action at once to apprehend and punish the men I have named, and to have the law breaking which I have specified stopped.

If you wish further information on this subject, you can get it from W. A. Brewster and N. K. Luxton, at Banff, and they can give you the names of several other men who are cognizant of the facts.

I should be glad to be advised of your action in the matter.

Yours respectfully,  
G. O. Shields.  
Regina, Assa.

Mr. G. O. Shields,  
New York.

Dear Sir:

I received from Mr. Smart a copy of your letter regarding infractions of the game laws in the Northwest. Those you mention, I observe, were chiefly in British Columbia, over which this government has no jurisdiction and in which, of course, its game laws are not in force. Throughout the Territories we have always had difficulty in having even our own laws enforced against the Indians. The various tribes are in charge of the Dominion Government, and it is claimed by that government that in many respects the Indians are not subject to our laws. When complaints are made that the Indians are slaughtering game we are advised that they appear to be observing the law. In addition to that fact, the Rocky Mountain Park, which covers a considerable portion of the game district of the Rocky mountains in the Territories, is controlled and policed by the Dominion Government.

I agree with you as to the importance of preserving the game which is left and am trying, as far as possible, under the difficulties we have to meet, to attain that ob-

ject. It is likely that at the approaching session of the Legislature new game laws will be passed under which the penalties will be made severe; and as far as is in my power I shall have those laws observed.

Your obedient servant,  
Horace Harvey,  
Deputy Attorney General.

#### ON THE TRAIL OF OLD TRAPPER.

I read, with special interest, "Hunting the Hunted" in RECREATION. The unusual interest arose from the fact that as the story was being published I was hunting on the same stream, among the same foothills and ravines in which Old Trapper hunted buffalo and fought Indians.

Buffalo long ago disappeared from the Western plains, leaving only their bones and scaled horns as reminders of their former sway, and of the reckless butchery of the cruel men who hastened their extinction. But while they no longer graze by the Western plains, leaving only their bones and turkeys and deer and an occasional bunch of antelope to furnish excitement to him who loves the chase; and while the Indians are no longer dreaded by the hunter, he may still encounter a mountain lion.

At sunset, November 20th, '98, in company with 3 fellow hunters, I descended from the Back Bone, a narrow ridge dividing the Brazos from the Wichita, into the famous turkey grounds among the foothills of the Wichita river. After following a winding trail a few miles, we came on the river, and making a few turns with the channel, reached a clear lake, where, finding plenty of wood, good water and grass we camped.

Soon our teams were staked out, our tent was up, camp stove arranged and supper ready. At dawn we set out to prospect for game. Two went down stream; Dave and I went up. In 2 or 3 miles, we reached a rough country, cut up by numerous deep gorges between which was a dense covering of small brush intergrown with briars and vines. We ascended one of these gorges just in time to see a large flock of turkeys vanish in the brush toward the river. Dave kept near the bank while I entered the brush, keeping about 50 yards from him. We crept along slowly, knowing that soon some of the birds would squat and give us a chance for a shot. There was a whirr and up went a big gobbler. Dave brought him down. Another crash of brush and up flew a second. Dave shot and missed. As he fired his second barrel he shouted to me to shoot, and pointed toward the river. Thinking a turkey was crossing I started on a run to the bank. As I reached the bank and raised my gun in position to shoot, my foot caught in a vine and I fell headlong, dropping my gun. As I rose and reached for my gun there was a

shot just behind me. I turned, and there lay a large panther snarling and clawing at the ground. He had been following us up the river and hearing the shots had crouched in the brush. In running I passed in front of him, within 2 yards. As he sprang over me and started to turn, the prompt shot of my companion settled him and perhaps saved me from some trouble. The turkeys meantime had escaped, and thinking we had had enough sport for one morning we returned, taking a few shots at squirrels on our way to camp.

During our 10 days' stay we saw many turkeys in flocks of 6 to 60. Among the cedar brakes of the hills, large flocks of Mexican, or top knot, quails could always be found, while the glades along the river abounded in Bob Whites. The Mexican quails are a little larger and fly swifter, but are not so game as the common quails. Mexican quails run rapidly and it is difficult to get shots on the ground. We saw several deer, but the innumerable crossings on the river and the vast territory in which they roam, render deer hunting a failure except to those familiar with the country.

We brought into camp 137 quails and 14 turkeys. All our turkeys were killed in daylight shooting, not on the roost.

On the plains and along the streams of North Texas there seems to be a greater abundance of game than for many years. The game laws are more strict and are being more faithfully enforced each year. As a result, game of all kinds is increasing, and we are likely to have fine hunting grounds for many years to come.

E. H. Hudson, Wichita Falls, Tex.

#### DEER HUNTING AT MILLINOCKETT.

With J. B. Carpenter and G. R. Horsman I left Boston for Millinockett, Maine, November 5, arriving next morning about 10 a. m. We were met at the station by our guide, John O. Hale, at whose camp on Lake Millinockett we purposed staying 2 weeks. After dinner we started for camp, a walk of 9 miles over a tote road through the forest. We entered the woods immediately after leaving the station and before we had gone 2 miles we saw abundance of deer sign. Thereafter we ceased all unnecessary noise and proceeded cautiously.

Mr. Carpenter, the veteran of the party, was the first to start game. He saw a grouse budding a tree and shot off its head in a way that elicited praise from the guide. We had not gone 200 yards farther when another grouse fell under the accurate aim of Mr. Carpenter.

At 2 p. m. we reached Smith brook, half way to camp, and after resting a few minutes again started. I took the lead and had gone perhaps a mile when I jumped

a doe, but did not shoot, as she was small and I preferred to wait for a chance at larger game. Before reaching camp Mr. Horsman dropped a grouse, making 3 in all. We got in about 4 p. m., a little tired but in excellent spirits.

The next morning we arose at 6, had breakfast and started out, intending to hunt until dusk; but though we hunted faithfully all day we returned to camp, tired and weary, without having seen game of any description.

Thursday we set out early, each taking a different direction and hunting alone. Mr. Carpenter came in at 4, having killed a buck. Mr. Horsman and I did not succeed in getting anything, though we found deer signs plentiful. No rain had fallen for several days, the leaves were dry, and it was impossible to travel without making considerable noise, though we moved with the greatest care.

Next morning we took in the buck shot the day before, and did little hunting.

Saturday we hunted separately. I had the good fortune to kill a large buck with handsome antlers, and on returning to camp shot a grouse from a tree.

Sunday we observed as a day of rest. Monday we hunted all day and returned in the evening with 5 grouse. That night snow began falling and by morning it was 8 inches deep on level ground. It was still snowing furiously when we started to hunt. Mr. Horsman shot a large doe, which he had tracked 2 hours. Mr. Carpenter got another buck. Wednesday we visited a point which extended into the lake near the camp. We spread out and started a doe, which I killed.

Thursday we decided to return home, and were obliged to break the road 9 miles through snow 20 to 35 inches deep. It was no easy task, and we were well nigh exhausted when we finally reached Millinockett.

We have nothing but the highest praise for our guide, John O. Hale. He has been a guide 25 years, is a thorough woodsman and hunter, an excellent cook, congenial and obliging. His camp is beautifully situated on the South shore of Millinockett. The lake affords good fishing and boating, and the camp is provided with several row boats and canoes.

J. D. Collins, Cambridge, Mass.

#### WHY THE BIGGEST ONE GOT AWAY.

Some time has elapsed since last we met. I have been bobbing about from place to place, while you have been growing in grace and popularity. So great have you grown that it would indeed be surprising if you could remember me as one of the friends of your youth.

Do you ever hear from this wonderful valley, the home of the Mongolian pheasant and other birds, all of which need your protection? We have good game laws here, but we also have good natured people, slow to wrath, so that the game hog flourishes. A fine crop of pheasants was mostly shot out before October 1st, and after that date the limit to the bag is too often all that the shooter can kill. The den of the game hog seems to be in Portland.

The farmers about us are exceedingly kind to sportsmen. I have had numerous invitations to shoot, and have been out twice, bagging 3 pheasants the first trip and doing somewhat better the last time, when I had the pleasure of shooting once at a pheasant, 3 times at ruffed grouse and twice at quail. I came home without having missed a shot, though all the shooting was in high brush or heavy timber. I am not always so fortunate; but no great number of birds would have given me the pleasure I derived from 2 or 3 difficult shots that day.

My excellent host and guide was a Mr. Macbee, who told me he has been reading RECREATION several years.

The chief object of this letter is to have you name the bird I have called ruffed grouse. I so named it because someone here told me that was what it was. I have never seen the bird before, but I should have called it a partridge. I found it in dense woods. I also found it successful in getting away from me. It has about all the earmarks of *Bonasa umbellus*, feathered legs, tail feathers like those of a turkey, and the cock has large black feathers on the sides of his neck; short bill, white flesh, and he who eats it wants more of it. What is it?\*

By the way, I had one misfortune while on the hunt of which I have been telling. My last chance was at a magnificent cock pheasant, on open ground. That bird owes its life to the fact that I did not have with me enough tools to explode the primer of a Peters shell which I had carelessly and unintentionally placed in my gun. That same lot of shells cost me many ducks last spring. I thought I had thrown all the lame shells away, but 2 had remained in my coat of many pockets. These intervened to save the life of the finest cock pheasant I have seen. What kind of a gun will explode those shells? Should one grind the primers down a bit before starting out? If these shells will not explode, why are they made? Would it not be well for Peters to keep up with the procession? We can't afford to go back to flintlocks.

T. B. M., Corvallis, Oregon.

\*It appears to be the Canada ruffed grouse, *Bonasa umbellus togata*.—EDITOR.

#### COON HUNTING.

One clear cool night in July as I was sitting on my back porch I heard a whine from old Quick, the winner of many a hard fought battle. My cousin, a lad of 13, made his appearance at the same time and said he would like to go coon hunting. I told him to hitch the pony and tell the boys to get ready. At 8 p. m. we started; Lester, Barny, Lawrence and I, and Quick.

Quick is a large black and tan dog, 12 years old and weighing about 60 pounds. He has never lost a coon, and will not run any other animal.

We set out across the wheat stubbles and had traveled nearly 2 hours before we heard the welcome bawl. The coon ran a quarter of a mile before he turned. Then he came back on a fence and passed within 50 feet of us. He took up through a pasture and over the hill to a thicket. When we reached the top of the hill we found that Quick had chased the coon into a slab pile. It was then 12 o'clock and as coons do not, as a rule, run much after midnight, we decided to return.

We had nearly reached the barn when we again heard the dog's deep bay. He went straight through the corn field to the fence and there lost the trail a while, but soon picked it up and gave us more music. The coon circled the woods and then worked toward the center. Quick treed him in a big oak. It was too dark to see and the tree was too big to climb, so we built a fire and waited for daylight. Quick took his post at the foot of the tree. We fell asleep and it was just breaking day when I awoke and wakened the rest. I told the boys to watch while I shot into the tree. There was a scramble, the noise of falling bark and then the coon leaped. Quick was at his service when he alighted and after a hot fight, killed him. A prouder dog was nowhere to be found, nor a happier bunch of boys. The coon, a large red one, weighed 21 pounds. We reached home at 6 a. m. tired but ready to go again.

H. Dugan, Greensburg, Pa.

#### THE PROSPECTOR AND THE BEAR.

The article in August RECREATION describing the bear of Alaska brings to mind an experience I had in Minnesota, in the early 90's.

I had been laid up in Duluth as the result of overwork while prospecting, and when I at last got around I was in rather poor trim. The first day out I met my friend, Z. D. Goodell, who wanted someone to look up some indications of iron he had run across the year before in the Hinkley country. In spite of my poor condition I consented to go.

I left the train at noon the next day and traveled about 10 miles before I stopped.

Camp in this section for a prospector is not an elaborate thing, usually consisting of a fire, a bed of balsam and a blanket, and consequently is easily made and easily struck.

I prospected a while that night and made plans for the next day. Ordinarily I am not nervous, but my illness had left me in a deplorable condition. After a restless night I got up early and went to a creek some 10 rods from my camp. After filling my tea pail I stooped and washed in the creek. Then I picked up my pail and, rubbing the water from my eyes, was about to start for camp when just over a log, not 10 feet from me, I saw the largest black bear it has ever been my good or bad fortune to meet. He looked to me as if he stood 7 feet high, and the surprised expression on his countenance was certainly curious to behold. I have often wondered who was the worst scared, the bear or I.

I had a 45-60 Winchester in Duluth and a 2 quart pail full of water in my hand, so I threw pail and water at his head, and I think by the spluttering he made that it struck him squarely on the nose. Then I started for that Winchester, and on the way picked up my blanket, skillet and pack-sack. I caught the train all right, and it was 2 weeks before I went back.

Washita, Hopkins, Minn.

A DRY SWIM.

732,405. Swimming Apparatus. John J. Gallagher, Chicago, Ill. Filed March 13, 1903. Serial No. 147,648. (No model.)

Claim.—A swimming apparatus compris-

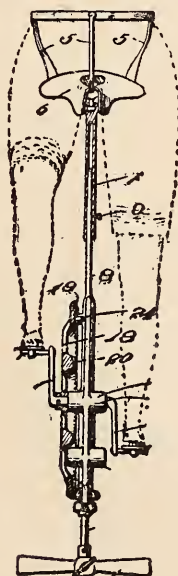

ing a saddle and saddle bar, in combination with a harness for attaching the saddle bar to the body of the swimmer, a propellor-wheel journaled at the end of the saddle bar, means for driving the propellor, in

position to be operated by the feet of the swimmer, and detachable treadles thereof.

FOR TIRED CAMPERS.

732,755. Knockdown Cot. Johan Linden, Peter Peirson and Charley E. Josephsan, Brooklyn, N. Y. Filed Dec. 17, 19, 1902. Serial No. 135,552. (No model.)

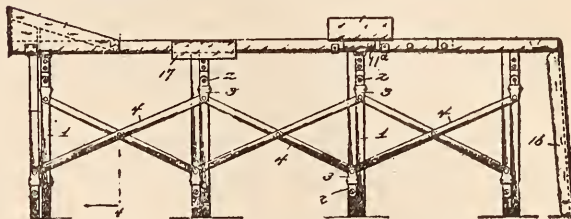

Claim.—1. The combination with a cot having an extension frame formed of crossed standards and lazy tongs connecting said standards; of a slotted strip pivoted to one of the standards, and a stud on the adjacent standard engaging the slot in said strip.

2. The combination with a cot having an extensible frame formed of crossed standards and lazy tongs connecting said standards; of slotted strips pivoted to the lower portions of the standards at one end of the frame, and lugs on the upper portions of said standards adapted to engage the slots in the strips and thereby retard the movement of the standards in relation to each other, etc.

SHOULD BE PENNED IN.

It is reported that J. C. Matthews, of Charlottesville, Va., killed 20 odd squirrels in one half day. If this is true, why not give him a number?

E. W. B., University of Virginia.

I investigated this report and received the following letter:

I killed and bagged 21 squirrels at 22 shots, but killed them in less than 1/2 day. I have bagged as many as 27 in 3/4 day. At this season it is hard to find squirrels between 10 in the morning and 3 in the afternoon. They do not like hot weather. They lie in shady places or go into their nests and take their midday naps.

J. C. Matthews, Charlottesville, Va.

If there are many such brutes as you roaming through the woods in your region it would be hard to find squirrels there at any time of day. It seems that most of the men in that county who shoot at all are decent men and quit when they get enough, so thus far squirrels are plentiful; but they will not continue so much longer if even you are allowed to run at large. I wish someone would give you a dose of the medicine you are giving the squirrels. Your number in the game hog book is 915.—EDITOR.

## A FOLDING BOAT.

736,623. Folding Boat. Ira O. Perring, Kalamazoo, Mich. Filed Oct. 2, 1902. Serial No. 125,627.

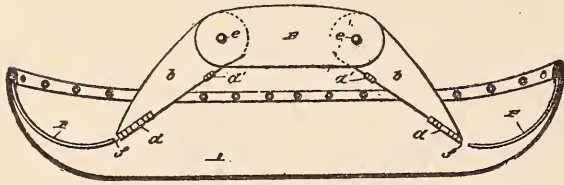

*Claim.*—The combination of a suitable flexible skin; a bottom consisting of central portions B B having extensions *b b* secured thereto by vertical pivots, the whole having cross grooves *c*; hinges *d*<sup>1</sup> arranged toward the inner end of said extensions; hinges *d* having tubular pivots arranged toward the outer end of said extensions; stem and stern ribs adapted to be inserted in said tubular hinge pivots; ribs C of suitable spring material adapted to be engaged and retained by said grooves when forced into position, whereby said skin is stretched and collapsing of the boat prevented, etc.

## GAME NOTES.

One night during Christmas week, several years ago, my brother, a friend of his and I went opossum hunting. We took a pack of hounds, a supply of pitch pine torches, and set out for Black Warrior swamp. At the swamp edge the dogs opened at full cry, trailing at a run, and we were barely able to keep them in sight. They ran 5 miles without a break. We felt sure they were following a coon, as an opossum seldom runs far. It turned out, however, to be a 'possum, an old fellow weighing 30 pounds, who put up a stiff fight when overtaken. These animals, though ready enough to do battle with anything else, generally feign death when attacked by dogs. This fellow took refuge in a hollow log. Four dogs, one after another, tried to drag him out. All got badly nipped and scratched and backed away, yelping with pain. Finally old Buck dashed in and, getting a grip behind the animal's ears, shook him until he was ready to "play 'possum."

J. L. Kirksey, Black Warrior, Ala.

I have just read in August RECREATION Herbert Earlscliffe's article on his trip up the Quilcene trail. He speaks of Chinese pheasants being numerous. Mr. Earlscliffe has evidently been misled by the fact that everyone out here calls ruffed grouse "pheasants." There are no Chinese pheasants North of Oregon that I know of, and certainly none in the Olympics. Have just returned from a trip to the headwaters of the Duckabush river, taking in the first pack horse ever to ascend it. Have fished

and hunted in these mountains since 1887 and they certainly can not be beaten for game. Duckabush is only 23 miles South of the Quilcene trail.

D. R. Tucker, Duckabush, Wash.

Joseph Kalbfus, chief game warden of Pennsylvania, and Joseph Berrier, one of the game wardens, arrested John Maxwell, Jr., and Edward Gibbons, both of Lilly, Cambria county, early yesterday at their homes and took them before Justice of the Peace C. A. McGonigal, of that place, on the charge of destroying a nest of Baltimore orioles and killing the young birds. These men were convicted of the offense charged and sentenced to pay a fine of \$50 and costs. In default of fine they were sentenced to 50 days in jail, one day for each dollar of fine imposed.—Pennsylvania Paper.

The names of Maxwell and Gibbons are recorded in the game hog book under the numbers 916 and 917.—EDITOR.

## A SUGGESTION FOR CHRISTMAS.

A yearly subscription to RECREATION furnishes one of the most delightful, instructive, entertaining Christmas presents you can possibly give a man or boy who is interested in nature, in fishing, shooting, amateur photography; or, who is fond of the woods, the fields, the mountains, the lakes or the rivers.

Many of the presents which people give their friends afford pleasure only for a few days, or weeks. A subscription to RECREATION means solid comfort a whole year. It reminds your friend 12 times during the year of your kindness and generosity. There are many men and women who for 5 years past have annually sent in long lists of names of friends, accompanied with a check in order that these friends might be made happy a whole year. Would it not be well for you to adopt this plan?

Try it and see how grateful the recipient will be.

"Where's Willie Brown this morning?" asked the school teacher.

"Please, miss, Willie's absent because there is a death in his family."

"Indeed? I'm sorry. Who is dead in Willie's family?"

"Willie."—Philadelphia Press.

Enclosed I hand you \$1 for a year's subscription to RECREATION. It is eagerly wanted by all the family, from white headed grandpapa to 2 year old boy, who wants to see the pictures.

Wm. W. Neal, Newark, O.

"Who were those 2 women who just registered?" inquired the hotel proprietor.

"Mrs. Mary McGinnis and her daughter, Miss Mayme MacYunes," replied the clerk.—Philadelphia Press,

## FISH AND FISHING.

### ANGLING VERSUS FISHING.

J. R. DAVIS.

Among denizens of the deep the tuna, tarpon, salmon, etc., may compete for the praise of the strenuous; but the gentleman of fishes is the brook trout, who will ever remain the typical antagonist of the angler, even granting Dr. Henshall's claim that pound for pound the small mouth black bass will furnish more forceful opposition. In beauty, charm of his environment and in the skill required for his capture, the trout is without a peer in representing the refinement of the art of angling. That there is an art in angling, will be readily granted by anyone who, for the first time, essays the use of appropriate paraphernalia. Progress in an art demands recognition of the highest ideals with depreciation of every attempt toward lowering them; and in the art of angling for trout there must, first of all, be acknowledged the distinction existing between angling and fishing, between the sportsman and the fisherman.

The former is a gentleman seeking sport; the latter an individual who goes out to get trout: the one paying due regard to the ethics; the other nonperceptive thereof, using business methods and miscalling his task pleasure.

For the art, the requirements are a propitious day, a favorable locality and suitable trappings of war. The first forbids angling on the first day of the season if the shrinking thermometer, and the hustling wind with its can of red nose paint, indicate that respectable trout are indoors shivering, and on days when roily streams present menus of worms. The second renders safe for the timid fish, thick bushy retreats; while the third, taboos rod, line and leader that would tow a whale. The maxims are:

First. The artificial fly is the only allowable lure. While to many it may savor of sacrilege to issue an edict of banishment on the classic angle worm with his curves of beauty, the passing of A. W. is inevitable.

The method of his use forbids his continuance in the brighter light of the present: a stealthy, sneaking, sleuthlike approach with a short line, a careful lowering of the impaled, wriggling wretch either over a bush or into the current to slowly grovel its lethal way onward; awaiting for the tug, which evidences hopelessness of escape; a mighty yank out, not of a vanquished peer, but of a mere morsel toothsome to the palate. A dentist may justify boast of his abilities as an artistic yanker; an angler, never! To Mr. A. W. sportsmen have said *adieu*, not *auf Wiedersehen*.

Second. The combination of rod, line, leader and fly, must be of sufficient delicacy

to yield naught but disappointment in unskilled hands, and to allow to the opponent a shade of advantage, thus furnishing an incentive to the angler for attaining greater skill. Observation of this maxim implies the return of fish too light for the tackle.

Third. The number of the catch is immaterial, none being preferable to even one, if the possession of that one necessitate disregard of the proprieties; but the size or weight should be of paramount importance, on the principle of age being more wary.

These requirements and maxims constitute the fundamentals of sport with trout. With bait and heavy tackle, the gradation from trout fisherman to pot hunter is imperceptible, and, while no objection is herewith urged against the methods of those who must have trout to eat, a most emphatic protest is entered against calling such methods sport. The individual who sullies the evening on his return with the question, "How many did you get?" classes himself hopelessly as a fisherman, not an angler. His opponent is not the wary trout, but his fellow fisherman; for his satisfaction comes not from contemplation of successful skill, but of the envy of his neighbor, and his pleasure is gauged by the intensity of the latter's chagrin. His gratification demands precaution against all preventable accidents of his work. He must reach the stream as soon as the law permits; for then fish are most plentiful. He must use worms; for, so early, the fish do not rise readily to the fly. His hook must be large enough to ensure an unyielding hold when once the barb has entered; his tackle must be strong enough to retain a good sized fish and, when occasion requires, to lift it clear out of water over bushes and to land. Where does skill enter the game? His victims are as sheep led to the shambles. If the law says 6 inches is the minimum length, he would stretch 5.99 inches to warrant retaining his catch; and he is of the kind who will supplement his catch with purchased fish; for he must boast of his number.

Skill demands more than he is willing to grant. It means that after the trout has been hooked, its chances for escaping are somewhat greater than for yielding up its life as an evidence of unfitness in the struggle. A sudden strain unallowed for, may part the leader, too great a tension may tear out the hook or wear away the tissues, allowing the hook to drop out on an unexpected reversal of movement.

Even when reeled in to the landing net, a final flicker of energy may mean escape. To feel it in the hand, when all possibilities are of the past is to realize that a battle

with the odds adverse, has been won; this is sport. After the struggle, instead of being greedily intent on more fish the captor does not hastily thrust his prize into the creel to be hauled out at the end of the day, dull, shrivelled and stiffened in curves, a la fisherman; it is quickly killed, cleaned and packed away in grass or leaves, to be a pleasure to the sight by lamplight, and in its honor a pipe is smoked while memory stores the incidents of the conflict. Endeavor to imagine a trout fisherman noticing, to say naught of appreciating, the scenery of his day's outing. He is after fish, not scenery.

Killing for the gratification of blood-thirstyness, for food or for business is not sport, and to abstain when the conditions are unsuitable is as distinct a sign of sportsmanship as to observe the proprieties. While the motive of the trout fisherman and of the pot hunter can not, under certain conditions, be justly condemned, especially on reflection of their being part of the nature of the beasts, the appeal is made to the man of refinement, to so deport himself in the company of the gentleman of fishes as to arouse emulation.

Should he be favored by the rabble with the title of crank, the angler may console himself by recalling the fact that at times cranks are indispensable for turning things, and that when trout fishermen are turned into sportsmen, the existing condition of the sport of angling will have developed into one affording more gratification to the higher nature of the animal man.

Meanwhile, let us insist on a recognition of the distinction between a trout fisherman and an angler.

#### A WOMAN'S ANGLING EDUCATION.

JUSTINA JOHNSON.

It is surprising how much a woman can learn about angling; even a woman who has never seen a fish caught and who knows only by faith that her angler really catches the fish he brings home. The truth is she stands in the best possible way to become an authority on certain phases of the subject, especially those requiring a calm and unprejudiced point of view. The angler himself is too much interested to be a fair observer. He is either gazing ahead through the bright glasses of anticipation or back through the gloom of the might have been, and can hardly be aware what he discloses in either attitude.

First of all, she learns when the season opens and the consideration this event demands. This may seem to the uninitiated a simple proposition; secure a copy of the game laws and there you are. Not so in reality. This A B C of fishing lore the woman probably learns abruptly in the

days of her youth, perhaps through heedlessly accepting an invitation for her newly acquired angler to dine out on that all important day. His look of horror, disgust—nay, of despair—when she gaily announces this fact to him and lightly adds that she supposed he could go fishing any time opens her eyes and lays a solid foundation for her angling education.

Soon she discovers that anglers are not as other men are in the matter of health; that they tramp all day in wet clothes, delight in wet feet, scorn umbrellas and rain coats and for every ill, mental, moral or physical, prescribe for themselves a day on the river. She soon accommodates herself to these idiocyncrasies and, since they do not kill her angler, ceases to worry.

She learns other things. In early days had she received 2 letters the same day from her angler she would have smiled tolerantly and imagined it indicated the fervor of his affection. Had she then the knowledge that years bring, she would have known that something shocking had happened to the fishing to have kept him from it and she would have been secretly gratified that in the distressful occurrence he turned to her for sympathy.

The years teach her other things. When she first heard the story of the mythical angler, condemned by all, who went fishing as soon as he returned from his wife's funeral, she resented this act. It is easily possible that, in some moment of depression, she exacted a promise from her angler to do otherwise. But, as the years slip away, she will see his heart turn to the woods in many a joy and in many a sorrow; she will find that nothing can solace him like the balm Mother Nature pours out; and she will no longer object. She learns, too, that as a topic of conversation, angling challenges the world. Wars and rumors of wars, strikes and epidemics, scientific discoveries and presidential candidates, all sink into insignificance before it.

I have frequently wondered how long an angler's enthusiasm would hold out were he absolutely debarred from showing his fish, from relating and expanding his experiences, and from reading or writing fishing literature. Not infrequently does my angler return from a trip with fish, the usual guilty conscience and vain regrets, and announce that he is now absolutely through with the whole thing that he is not going a-fishing for a long time; perhaps never. He puts away his tackle with an air of finality and looks virtuous. Then he begins to tell how he did catch them and why he didn't catch them to anybody who will listen, and by the time he has told the story a few times his enthusiasm has revived to such an extent that he is ready to order his horse,



his lunch and his breakfast, and start out again.

Sometimes, after the season is well advanced, when work is slack and fish are plentiful and anxious to be caught, the angler seems to get started and not be able to stop. Out he goes, day after day, day after day, planning one trip while returning from the last, seeming to think of nothing else, until something—a flood, a sickness, or a business complication—happens to stop him, and it would doubtless astonish the uninitiated to hear his expression of gratitude when this occurs.

An unprejudiced observer will find it hard to account for the chronic guilty conscience with which anglers seem to be pursued; but all must admit that they usually start on a trip in either a defiant or an apologetic mood. Other men take their vacations and playspells as though entitled to them, and it is surely no more reprehensible to take a day on the river than one at the races or at a camp meeting. This feeling in the angler can hardly arise from regret at deserting his family, for he leaves them with composure to go to a political convention or to a college reunion. Neither can it be because of the expense, for the angler hoards his money for that express purpose in an open and unblushing way. Yet invariably the news of a newly planned excursion is broken in the gentlest possible way, the angler endeavoring to appear at ease.

This frame of mind has its advantages. Like Eugene Field's boy just before Christmas, "he's as good as he can be," and it is not an altogether undesirable thing to have your angler occasionally in the frame of mind where he will cheerfully dig the garden, chop the wood and mend broken windows.

A woman hears a great deal of times and seasons: when the trout are at the cold water, on the riffles or in the small streams; when the bass are most anxious to be caught, and the kind of bait they prefer. She finds that certain kinds of rods and reels are much appreciated, and secretly wonders if the chief difference does not lie in the price. She becomes an expert in making minnow nets, and is convinced that catching trout with worms is the unpardonable sin. She comes to handle tenderly the most disreputable old shoes and other articles of clothing; yet in spite of all this, years of observation probably fail to disclose to her the reason for all the peculiarities of men who fish.

#### A DAY WITH THE LAKE TROUT.

May 20th, in response to a letter from my guide at Lake Keuka that "They are biting," I made hurried preparations and

in due time arrived at Bath, 8 miles from the lake. The operator called up a liveryman, who came with a team, and 40 minutes later we were at the hotel in Hammondsport. Five o'clock the next morning found me on the dock admiring the beauty of matchless Keuka. Breakfast of fried trout was cut short by the boat's whistle, and once on board the Halsey I snapped a few pictures before accepting the invitation of Frank Conklin, the pilot, to join him. The boat's destination was Penn Yan, 22 miles distant, fare 10 cents to any point on the lake. The day was fine, and from my point of vantage in the pilot house I found the scene deeply interesting. The bluffs on either side as far as the eye can reach are covered with vineyards, and there are huge wine cellars on every hand. Hundreds of handsome cottages nestle by the lake, and as the steamer crosses and recrosses the water we who are shut in offices so much feel content.

At Catawba I found my guide awaiting me, and he said if I did not catch fish there would be no bill to pay. As the steamer pulled out we made the lines ready, with Seth Green gangs and sinkers weighing 14 ounces. A Seth Green gang has 3 treble hooks about an inch apart, strung on fine gut. Two feet above the sinker a single gut leader 12 feet long is attached. About 8 feet nearer the top another 2-foot leader is placed, and the same distance apart 3 more, each a little longer than the one below, 5 in all. These are baited with a little fish called sawbelly or alewife. There is no swivel, and the bait is not intended to revolve like a spoon, but by giving the fish a little curve as the hooks are fastened, it has the appearance of a leaping fish. I used 60 feet of line and the guide 90. The lines were gently zigzagged through the water as we glided back and forth, and presently I hooked a big fish that dashed about like a horse, despite the weight of the heavy sinker. My fish took all of its line, which I partially regained when the fish sought the bottom, the line flying through my fingers until they smarted. The struggle did not last long. I could look down through the clear water and see the fish darting this way and that, now standing on its head and again darting under the boat. When I had brought the fish to the side of the boat Will missed gaffing it, and away it went for the bottom. A second time there was a miss, but the third time the fish was landed, and when weighed it proved to be an 8 pounder. While off Bluff Point, a well known bit of water for fish, I struck again, and we landed a 3½ pound trout, which had taken the hook on the upper leader. I lost another trout that had taken a hook on one of the lower leaders. For 2 hours

we trolled back and forth without a strike. Then we boated a 4-pounder and one weighing a little less. Later, Will caught a trout as large as any of mine save the first one. By that time Mrs. Dart had raised the white flag on the boathouse that denoted dinner was ready for us. We did full justice to the fried perch and other good things and soon returned to the lake.

The wind had fallen and the surface of the water was like a mirror as we rowed down the left fork of the lake and past Branchport and Drakes, the latter a country place perfect in every appointment. A loon floated on the water, as light as down. Graceful gulls flew near us. It is not "all of fishing to fish." Returning, the wind rose again and soon Dart hooked a fish half a pound lighter. Then the whistle of weighing  $5\frac{1}{4}$  pounds, while I boated one the returning boat was heard, and we returned to the dock. Five of our fish weighed exactly 24 pounds.

A. T. England, Afton, N. Y.

#### TWO NEW PATENTS.

733,836. Fishing Rod. Allen E. Hall and William G. Smith, Philadelphia, Pa. Filed Feb. 7, 1903. Serial No. 142,365. (No model.)

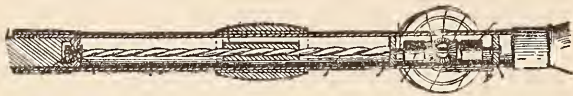

*Claim.*—1. In a fishing rod the combination with a tubular casing having a slot therein; of a screw shaft journaled within the casing, a sleeve slidably mounted on the casing and engaging said shaft, a toothed sleeve outside the casing, means for imparting motion thereto in one direction from the shaft when rotated in either direction, a reel inclosing the sleeve and adapted to be engaged thereby, and means for retracting the sleeve from engagement with the reel, etc.

731,226. Fishing Reel. Edward D. Rockwell, Bristol, Conn. Filed April 15, 1903. Serial No. 152,650.

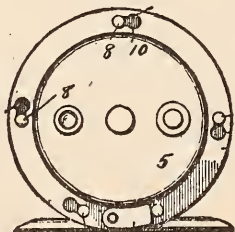

*Claim.*—The combination, with a frame having side plates, one of which is provided with openings, of rods projecting from one side plate and having extremities passing through the openings of the other side plate,

a locking ring provided with keyhole slots movable on one of the side plates, and means for securing said locking ring against displacement, etc.

#### NIBBLES.

Would say to A. R. Prettyman that carp bite best with an incoming tide in rivers of the size he mentions, and in early morning and evening in land-locked waters. I have had most success with hand lines 25 to 40 yards in length, rigged with sinkers heavy enough to cast line full length and hold it anchored. Use 3 No. 5 Carlisle double snooded hooks; fasten them 8 inches apart, the first a foot above the sinker. The best bait for carp is dough made from kimmel, or German rye bread, by soaking the bread in water, squeezing it nearly dry, and kneading to the consistency of putty. Put it on the hooks in pear shaped lumps. If properly made it can be cast several times before it drops off. No one who has landed carp weighing over 2 pounds will question their fighting power. Their table quality depends largely on how they are prepared.

T. J. Grimm, Phila., Pa.

For some time past some persons have been catching trout in Sink Run reservoir, near Tyrone, by means of lay outlines, baited with live bait, contrary to the act of assembly. It is said that trout measuring 12 to 20 inches in length have been caught in this illegal manner during the past few weeks. An investigation which has been quietly pursued by officials of the Blair county branch of the League of American Sportsmen resulted in information being made before Justice G. C. Davidson, of Tyrone, charging J. L. Troutwine, proprietor of the Pennsylvania House of that place, with the above named offense. The defendant pleaded guilty to the charge and was immediately fined \$25 and costs, which was paid.

This is the fifth illegal fisherman brought to book through the efforts of the League within the past 60 days.—Altoona, Pa., Mirror.

Troutwine should change his name to Trouthog. Anyway it has been recorded in the swine register as No. 918.—Editor.

"At least there is some variation," said the "ham" actor as he dodged the shower of applause; "they are throwing coal instead of eggs."

"Well, it is egg coal," remarked the manager as he raked in the lumps.—Exchange.

Getting up a club for RECREATION is just as easy as falling off a log. The premiums are as near something for nothing as anything I know of.

M. J. Taylor, Camden, Mich.

First Cricket—That place over there is the hearth, isn't it?

Second Cricket—Yes.

First Cricket—Are you on?—Exchange.

## GUNS AND AMMUNITION.

Anybody can shoot all day, but a gentleman will quit when he gets enough.

### A MISS FIRE AND A TIGHT SHELL.

DR. B. F. JONES.

For some time I had contemplated a short trip after deer. The idea culminated in a start December 15th last. The party consisted of John Andrew, Clarence Chapin, George Harriman and me. The ground in the valley was covered with 5 inches of snow and the weather was exceedingly cold. The first night found us camped 5 miles West of Market lake. The second, at the ranch of Frank Reno, on Birch creek, within 6 miles of Lost River mountain, our hunting ground.

Our trip took us over country infested with jack rabbits, and hundreds were seen skimming through the dense sage brush. We secured a few sage hens along the road and practiced shooting on a few of the festive jacks. We located our camp in a deep canyon where fuel was abundant. The first day Chapin went South while Harriman and I went North. It becoming evident that the deer were lower down, we went lower and soon found a trail of 11 on the slope of a ridge. They crossed a deep gulch and went on over a second ridge. When we reached the top of this we saw our game ascending another ridge. They were plainly in view, but so far away that they appeared no larger than rabbits. Our efforts to get above them failed, as they went so high that it was impossible for us to follow through the deep snow.

A tramp of a mile farther and a large bunch was started on a sunny slope studded with scattering mahoganys. There was no opportunity to approach in any direction and they escaped without our getting a shot. It was then the middle of the afternoon and we started toward camp. Soon we found a trail of 8 deer going our way and we followed. When we had gone nearly 2 miles we heard a fusillade ahead of us and saw a man on a distant ridge. It was evident he had found the trail we were following. He fired 14 shots and slightly wounded a big buck.

As we came up, a doe and a spike buck jumped out to my right at the lower edge of the timber, but afforded no shot until they crossed the gulch and began to climb the next ridge. Then a shot rolled over the buck. As we were near camp it was a short job to get the deer there. On our way I killed 3 sage hens. The next day, although we traveled from dawn to dark, not a deer was seen by either of us.

We decided to break camp next morning, and the following day was consumed in finding a new camping place some 5 or 6 miles farther North. The day after we

moved, Clarence, George and I hunted the mountains North of our new location. Two miles from camp a trail of 7 deer was found but we could not unravel it.

George and Clarence finally started up a long ridge while I went down, thinking perhaps the deer might be lower. As I approached a rocky point covered with small mahogany out walked 2 large does into an opening, and stopped. They were not over 50 yards from me. I dropped on one knee with the gun across the other and pulled the trigger. The click of the hammer started them and I hastily recocked and shot at them while running. At the report 4 more sprang from under cover and stopped, watching me frantically try to extract a tight shell. They seemed to know there was no hurry, and walked leisurely out of sight.

Did I swear? Well, no; I knew I could not do the situation justice, so did not try. I watched the deer out of sight and returned to camp where I succeeded in removing the offending shell. The other fellows arrived at dark without having seen a fresh trail. Next morning we broke camp and started homeward.

### CENSURE FOR WINCHESTER.

I am a great admirer of the Winchester gun and am sorry it is not being kept up to the standard as a modern arm. Furthermore the action of the Winchester Company in withdrawing its ad from RECREATION was childish.

The Winchester people are clever in introducing new cartridges, but they still hold up their antiquated weapons as the highest product of the gun maker's art. In the nearly 40 years of their existence they have never brought out anything really new. They have merely modified the old Henry system to shoot the longer cartridges. Their only attempt to discard the slow, cumbersome and dangerous tubular magazine resulted in that monstrosity known as the '95 model. They tried to get the Chinese government to adopt it, and later claimed it had been adopted by Uncle Sam. Its use must have been confined to the Filipino scouts and Indian police. Will some army officer please explain? The '95 model is lacking in the 2 requirements of a modern arm in that it can not be loaded with a clip and has nothing to take the place of the 15th century hammer. It is anything but a handsome gun.

The Winchester people do make one good gun, the Lee straight pull; but the bullet is too small and light for big game

or for long range work, and the bore is hard to clean. The 7mm. Spanish Mauser is a cartridge generally liked, but no American arm is made to use it.

I once wrote the Winchester Company and asked if they would make the Lee for that cartridge and the 8mm. and 9mm. They said they would not, but that the '95 was amply powerful for anything I might wish to shoot!

The Savage is a pretty little gun, but I wish they would make a packet rifle for the military cartridges. I do not like the bolt action of the Krag or its European variation. Can you give us an illustrated account of the new army rifle? Will common people, like the editor and me, be allowed to buy and use it?

If the sale of arms to savages were stopped the Winchester Repeating Arms Company would break in 2 years. The fact that from '91 to '94 they sold 200,000 of the model '73, 44 caliber, shows where they sell their goods. As a consequence any sportsman who goes to a savage country needs the biggest type of arm for his own safety. No wonder Winchester has quit advertising. While they are busy making trade guns will not someone bring out the ideal gun; that is, a straight pull or lever action packet loading repeater?

I see by the A. D. G. H. that Winchester has brought out a 10 shot automatic 22 caliber repeater. A guilty conscience needs no accuser, so they took their ad out of RECREATION rather than face the adverse criticism of its readers. I hope you may succeed in killing the automatic shot gun. It would certainly prove the game hog's ideal weapon.

Can anyone give the trajectory and velocity of the 7mm. Mauser and the 8 and 9mm. Mannlicher bullets?

C. L. Adair, Cleburne, Tex.

#### HALT ON MURDEROUS GUNS.

I buy RECREATION from the book stand and you may be sure I never miss a copy.

I protest against the Winchester automatic 22 caliber rifle and the automatic shot gun, which, I hear, is likely to be made.

While such a weapon as a 10 shot 22 caliber automatic rifle may possibly be used by a sportsman, no decent man would ever be guilty of using an automatic shot gun. While a pump gun may possibly be classed as a sportsman's weapon, when it comes to an automatic shot gun it is time to quit.

There is no need of an automatic. No skill or individuality is required there. It is not everyone who can use his hands quickly enough to make the sliding forearm repeater shoot rapidly, but if the automatic comes game hogs will simply pull the trigger

and slaughter the game while it lasts. Possibly the time-worn argument will be used that it is the man and not the gun who is the game hog. True, but the game hog exists. Then why arm him with more deadly weapons than he now has?

I should like to hear what brother sportsmen have to say on this subject.

Let us hope that the Winchester and, in fact, all gun makers may consider the calamity that such a gun would be to the game. The pump gun is bad enough. Let the murder weapon craze stop at that. God knows the birds are decreasing too fast now. I should honestly be surprised to see such a gun advertised in RECREATION, which is, and I hope always will be, in the lead of the many journals now published for sportsmen, in cleanliness and purity of sports.

I wish you Godspeed in the extermination of the game hogs.

S. E. Sangster, Ottawa, Ont.

#### THE COLT SLIDE ACTION.

For the information of E. J. Pratt, of Rushville, N. Y., I will say I have used a Colt 38-caliber the past 10 years. Colt guns are accurate, hard shooters, easy to work, safe, and in every way reliable. In deer hunting in Indian Territory, where I do my winter hunting, quick shooting after the first shot is essential. The greater part of the game bagged is dropped on the run, and the Colt forearm action is much more conducive to quick aim than any lever action can be.

The loading of the second shot does not necessitate the removal of the arm from the face and the very action itself brings the piece back to position for the eye. The action is natural. I wonder that the Colt people do not build a small caliber high velocity rifle with their forearm action. For big game it certainly would be ideal. I have used all other leading rifles, from Sharp's up, and never felt that I had the real gun until I used Colt's.

The Colt, like all the others except the Savage, depends on gravity in placing the loaded shell in the chamber. None of them will jump in loading if held properly, and the Colt, according to my experience, is less liable to do so than the others, if mis-held.

As far as speed and accuracy in shooting at a moving object is concerned, the Colt leads by many laps and none shoots harder or nearer the bull's eye.

J. W. Farrell, Weir, Kansas.

#### WHAT A DIFFERENCE!

In view of the attacks some of your readers have made on the Savage Arms

Company, I wish you would print a letter I have just received. I wrote the Savage people last week, calling their attention to a minor defect in the barrel of a rifle I bought from them 2 years ago. This defect could have been easily remedied; in fact I called their attention to the matter more to see what their attitude would be respecting it than from any other reason. The lapse of time would have been sufficient had they been disposed to take advantage of any excuse.

The success of the Savage Arms Company is not surprising when they treat their patrons in this manner.

R. G. Bickford, Newport News, Va.  
Utica, N. Y..

Mr. R. G. Bickford.

Dear Sir: With reference to your favor, would say that we have received your rifle No. 26,881, and to avoid any possibility of trouble we are fitting the rifle with a new barrel and refinishing the arm complete. We will see that the rifle is carefully targeted, and that the target is sent for your inspection. We believe you will have no further trouble and that your rifle will give you the best possible service.

This work shall have our best attention and the rifle will be returned at the earliest possible date.

Savage Arms Company.

What a difference between Savage and—well between Savage and a certain New Haven man, for instance!—EDITOR.

#### ANSWERING STANLEY WATERLOO.

In September RECREATION Stanley Waterloo asks for advice as to how to have a gun stock bent so he can shoot right-handed, using his left eye. This can be done easily by one of the large gun repair shops in Chicago, or by D. M. Le Fever, Sons & Co., Syracuse, N. Y. I have seen many shooters who, having lost the sight of their right eye, have had a stock bent as described, and who could do as good shooting as they did before. In watching these men shoot one would never know they were using the left eye. From a casual glance at their guns you would never know the stock was different from the ordinary. If Mr. Waterloo will have his gun stock bent in this way he can enjoy any kind of shooting the same as before.

Harry L. Yance, Racine, Wis.

In September RECREATION I notice a communication signed Stanley Waterloo, Chicago, in which the writer says that owing to an accident to his right eye he has been unable to use it when shooting, and asks advice as to how to overcome the difficulty. In reply will say I have had stocks made for my guns with a crook just behind the breech, which enables me to shoot

from the right shoulder with the left eye. The crook in the stock brings the barrel exactly opposite the left eye.

Geo. M. Savage, Detroit, Mich.

#### WOODCHUCK TALK.

I wish to add my experience in hunting woodchucks. Have used both the Stevens 25 R. F. and 32-40-165. Chucks are hard to kill. I hold on the neck, if he shows that much; then should the aim be a trifle high I have a chance to kill. I once made a peculiar shot on an old chuck. He was headed for his hole at full speed. I made a snap shot with my 25 and caught him just back of the shoulders. He turned several somersaults and fell stone dead. Have a friend who uses a 32-40 smokeless, soft nose bullets. He hit a chuck at 70 yards in the head. It quivered and sank as if struck by lightning. I prefer my 32-40 with good target sights. This is powerful enough for chucks and is accurate up to 400 or even 500 yards. I use about 1 part tin to 30 of lead, and Du Pont No. 1 smokeless powder.

RECREATION is a friend to man, bird and beast.

W. O. Isaacson, Jamestown, N. Y.

I have read lots about woodchuck shooting and the right rifle to use. I do not claim every woodchuck I shoot at, but I do claim every one I hit. I use a Winchester 22 short with a mushroom bullet, and it will stop anything it hits. I have used the Winchester smokeless and greaseless. It is a fine cartridge, but when it comes to rabbits or chucks give me the mushroom every time.

C. M. Smith, Campbell, Mass.

#### A NEW REVOLVER.

728,896. Revolver. Andrew Fyrberg, Worcester, Mass. Filed Oct. 28, 1901. Serial No. 86,186.

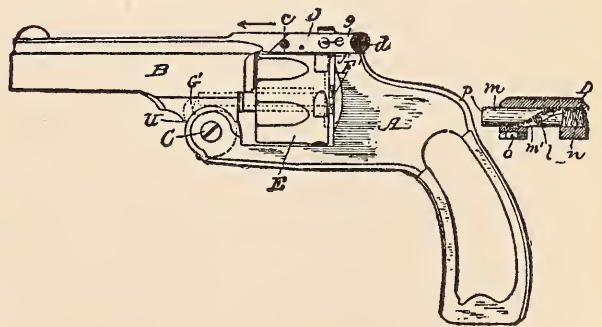

*Claim.*—In a revolver, the combination of top frame D the upper part of frame A, and cylinder E, with the thumb latch d, its

pivot *e*, spring *h*, fastened at one end to said top frame *D*, and whose free end bears against the inner end of thumb latch *d*; lever *j*, arranged under pivot *e*, and provided with the hook *j* at its rear end; also provided with the stud *l* at its forward end; the pivot *k* of said lever, transverse spindle *m*, provided with the spiral groove *m*<sup>1</sup> adapted to receive the aforesaid stud *l*; spring *n*, for exerting a longitudinal pressure on spindle *m*, and means for controlling the longitudinal movements of said spindle and for keeping it from turning.

#### THE BAKER GUN.

I have owned a great many guns of all grades, names and sizes, and have dealt in them the past 12 years, so I speak without bias. The first and most important point in a shot gun or other fire arm is safety. A sportsman who, in buying a gun, does not first consider the safety appliances is not qualified to handle a gun in company. There is only one hammerless shot gun, the Baker, that is absolutely safe. Other makers in describing their guns are careful to tell you about the safety thereon; but when you have had your hat shot off by a gun with all the safeties on, as happened to a friend, you begin to doubt the veracity of the maker of that gun.

The Baker is the best gun in the world. While this is a bold statement a little comparison will prove the truth of the assertion. It has shooting power equaled by few and excelled by none; better material and workmanship than can be found in any other gun at twice the price; balance and ease of operation excelled by none; most simple cocking mechanism and lock work; engraving and general appearance to suit the most fastidious; inability of any combinations of powder and shot to shoot it loose; and the first and only absolute safety.

W. M. S., Deposit, N. Y.

#### HOME MADE WICK PLUGS.

I have been having great difficulty through the damp weather in keeping my rifles, pistols and shot guns clean inside. I saw in RECREATION an ad of wick plugs, and wished to learn whether they would do the work claimed for them. I made some to experiment with. They are excellent, and will keep any gun they are put in absolutely free from rust. If you do not care to go to the expense of buying wick plugs, you can do as I did, buy some common lamp wicks and cut them into strips, which when sewed up round will fit your gun barrel. Before sewing them together run a cord through the whole length of the wick, leaving enough of this out to pull

through the barrel, after the wick is finished. Sew the pieces together with the cord in the middle, making a round plug.

After the wicks are thus sewed together, making the joints tight, soak the plug in vaseline. Then put the cord you have left attached to the plug through the barrel from the breech, pull the plug through and leave it there. With these plugs left in any fire arm, you need have no fear of finding it rusted, even if left several months, though, of course, all fire arms should be looked over occasionally and re-oiled.

Harry L. Yance, Racine, Wis.

#### A NEW LEFEVER PATENT.

732,420. Breakdown Gun. Charles F. Lefever, Syracuse, N. Y., assignor of one half to Daniel M. Lefever, Syracuse, N. Y. Filed April 13, 1901. Serial No. 55,660.

*Claim.*—1. In a breakdown gun, the combination with a frame and a barrel, pivoted hammer, an extractor bar having a recess, a cocking lever pivoted to the frame at the rear and above the hammer pivot and provided with a forward and upward extension projecting into said recess for engaging and moving the extractor in reverse direction, a cocking member carried by the barrel and engaged with the upper and rear

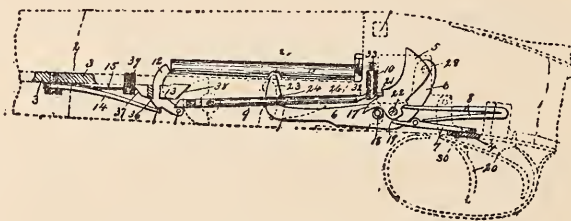

faces of said extension, and a shoulder on the lever engaging the hammer in front of its pivot for cocking the hammer, etc.

#### SINGLE TRIGGER GUN.

732,531. Single Trigger Firearm. James A. R. Elliott, Kansas City, Mo. Filed May 10, 1902. Serial No. 106,714.

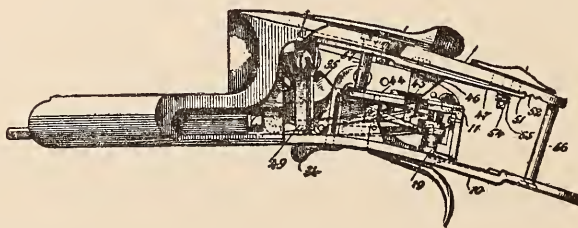

*Claim.*—A firearm having a plurality of hammers, sears for engaging with the hammer a sleeve mounted for rotary and vertical movements, lugs on said sleeve

for engaging the sears, means for causing the rotary movement of the sleeve in opposite directions for engagement with either sear first, and a trigger for causing the upward movement of the sleeve.

#### IS THE PUMP GUN A GAME HOG'S WEAPON?

Horace Greeley once said, "I do not say that every Democrat is a horse thief, but I do say that every horse thief is a Democrat."

The same savage logic may be applied to the use of the pump gun. I do not undertake to say that every man who uses a pump gun is a game hog, but I do say that nearly all market hunters, and a large percentage of game hogs who do not sell their game, use pump guns. The moral is obvious.

I have traveled all over the settled portions of this continent, and over large portions of it that are unsettled, and wherever I have found decent sportsmen and heard any question raised as to the use of the pump gun, these men have invariably said in effect,

"I would not be seen with one of those guns in my hands. It is a market hunter's and game hog's weapon, and, in my judgment, no gentleman would ever use one."

J. G. S., Troy, N. Y.

#### SMALL SHOT.

I note what Mr. Powell says in RECREATION about my comments on his Alaskan story. His proposition to bet \$1,000 that he can hit a target 5 feet square at 200 yards with a pistol, as a proof of his ability to kill running caribou at that distance, is too absurd to deserve notice. The vital part of a caribou does not exceed  $2\frac{1}{2}$  feet in diameter or  $6\frac{1}{4}$  square feet of surface, while a target 5 feet square contains 25 square feet of surface. The target is 4 times larger than the animal named, and has the advantage of being stationary, and the distance to it known. Any fair shot can easily hit such a target at 200 yards with an accurate long range pistol, but there are few men who can with any certainty stop running caribou at that distance with the same kind of a weapon. Mr. Powell's \$1,000 proposition like his other statements sounds big, but there is nothing reasonable about it.

G. A. Tremper, Helena, Mont.

Black Jack seems to think Double Barrel was joking about killing 6 chickens on the flush with a pump gun. There are many hunters who can get 3 to 5 every time. I used a Winchester pump gun, '96 model, 2 years and have often killed 3 quails on a rise. Once I got 4 out of 5 shots, but the birds were scattered and did not all get up

at once. I remember shooting at one bird 3 times and killing him the third shot. I can get 2 shots with a Winchester pump where anyone can get 2 with a double gun. I am using a Remington hammerless now. The pump gun was ruining my shooting; I was trying to get in too many shots and the first was always too close. I find the Remington a splendid bird gun. I hunt with a friend and we kill 30 to 50 quails a day, but I get out only 4 or 5 times in a season.

L. M. Mitchell, Augusta, Ga.

Will some readers of RECREATION give their experience with the 25-10 Stevens? Are Harrington & Richardson's revolvers accurate and reliable? I would inform C. W. Linberger that the penetration of the 25-20 Winchester is 9 soft pine boards  $\frac{7}{8}$  inch thick. It will do good work up to 200 yards. In reply to M. J. Burns I would say that the velocity of the 22 Winchester center fire bullet is 1,400 feet a second, at the muzzle of the gun, and that smokeless powder shells are just as good as black powder shells, besides being much cleaner. However, it will not do to leave a gun uncleaned long after shooting smokeless powder in it, as the residue is exceedingly hard to remove after it dries. If it is not removed it will injure the accuracy of the gun.

H. H. Anderson, Rossville, Kan.

737,376. Shooting Spectacles. Josef Ender, Landeck, Germany. Filed May 19, 1903. Serial No. 157,808. (No model.)

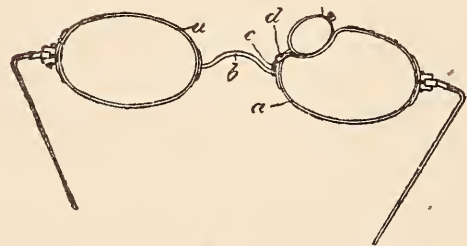

*Claim.*—Shooting spectacles, having an aiming lens arranged to be adjustably fixed in a recess formed in the rim of one of the glasses near the bow.

Will you kindly give readers of RECREATION the benefit of your opinion of the new Winchester, 22 caliber, automatic rifle which I have seen recently in a gun store in this city, and in which some friends of mine and I are interested

S. S., Chicago, Ill.

I have not examined the Winchester 22 caliber automatic rifle, but I take it for granted the workmanship and materials are all right. I do not, however, like the idea. God knows the game is being slaughtered

too fast with the guns we have now, and I dislike to see another come on the market that is still more deadly. Please read my editorial on automatic guns in November RECREATION.—EDITOR.

Mr. E. W. V., Watertown, N. Y., wishes to hear from someone using the 22-7-45 Winchester. I have one and it is the most powerful little gun I ever handled. It can not be beaten for squirrels, woodchucks, etc. When I first bought the gun I experienced the same trouble E. W. V. states, especially with U. M. C. shells, but have had some made with a harder lead and have used 200 of these without one shell's becoming jammed. I am careful to keep magazine tube well oiled. The shells in this gun should never be worked through the action as the magazine tube can be easily removed and shells slipped out.

L. J. Tooley, Kalamazoo, Mich.

In September RECREATION E. G. Dewey tells his experience with a 30-30, and I beg to suggest that he should use soft point bullets the next time he goes out after big game. He says he shot and hit a deer 5 times, and that no one bullet hole in the animal's skin measured  $\frac{3}{4}$  of an inch in diameter. It is evident, therefore, that Mr. Dewey used full metal patched bullets. Had he used soft point ammunition and shot the buck 5 times the animal would have been so badly mutilated that Mr. Dewey would have had trouble in collecting the meat.

Subscriber, Los Angeles, Cal.

In June RECREATION, A. C. Rawson asks how to keep spots out of his gun barrels. I have used one gun 6 years and the barrels are perfectly clean and bright to-day. There has never been any black powder used in it, but all kinds of smokeless, mostly Dupont.

There has never been any water put in the barrels intentionally. After shooting, usually the same day, it has been wiped out with a cloth moistened with oil until a clean cloth does not soil.

E. R. Emery, Houston, Tex.

What firm supplies the army with Krag-Jorgensen rifle cartridges? I understood there was to be an improvement made in this cartridge, securing greater velocity, but have been unable to learn anything further. RECREATION is certainly the cleanest magazine for sportsmen I have ever read.

C. R. H., Elwood, Ind.

Most of the cartridges used in the army and navy are made at government arsenals, though some are bought from the various factories.—EDITOR.

I prefer Robin Hood powder to any other on the market, after a long and exhaustive test of it. I shot a good deal of it at the trap and in the field last summer. I made one of those old fashioned, long range shots, such as I used to sneer at, at 90 yards or thereabout, putting 5 shot in a prairie chicken and killing it with  $3\frac{1}{4}$  drams of Robin Hood. No other powder would have done it. From patterns I afterward made I find it was not a scratch shot.

R. H., Topeka, Kan.

I have a 32-40 rifle, 1893 model in which I have been using U. M. C. cartridges with good results. Recently I bought a box of Winchester cartridges for this rifle and find they drop 6 inches in 50 yards and 4 feet at 300 yards. Will some reader of RECREATION please explain.

RECREATION is the best sportsmen's magazine published. Every sportsman should read it and should help protect the game.

J. A. Dodge, Ohio City, Col.

In September RECREATION E. C. Barnes inquires for a rifle of smaller caliber than 22. I do not know of a smaller caliber arm, but should think the thing for him would be an air rifle. These are easy to clean, the ammunition is cheap and one should satisfy any man who can not be pleased with any of the 22 caliber rifles now on the market.

Harry L. Yance, Racine, Wis.

I send herewith a 22 caliber shell which, as you will see, has no mark on the outside that could account for its going off. This cartridge exploded when pumped into the chamber of a Savage rifle. The gun was at safe and nothing hit the cartridge. Should like to hear from any reader of RECREATION who has had a similar experience.

Fred Lambart, Lindsay, Ont.

Answering A. W. Crampton's inquiry about Robin Hood shells and powder, would say that after using many brands of ammunition I consider Robin Hood unexcelled for pattern and penetration.

A. H. Scriver, Champlain, N. Y.

What's the matter? What are you shivering about? demanded the first rabbit.

There's a dude out there with a gun, replied the other.

Well, he doesn't see us at all.

That's just it. He's aiming at something else.—Philadelphia Press.

Every lover of outdoor sport should read RECREATION.

I. W. Fogg, Gorham, N. H.



## NATURAL HISTORY.

When a bird or a wild animal is killed, that is the end of it. If photographed, it may still live and its educational and scientific value is multiplied indefinitely.

### A BIRD TRAGEDY.

LAURA J. RITTENHOUSE.

It was dark when the boys drove up to the house with their load of Christmas greens. They came trooping in noisily, Bob, holding somewhat gingerly, a wounded hoot owl. The bird's big luminous eyes had been his undoing, for seeing them glow in the shadowy foliage of a beech tree, the boys, with a sling shot all too skillfully aimed, had brought him down from his perch.

The boys were sorry when they found that their victim was neither a coon nor a wildcat, for no one had the heart to kill him and end his suffering, yet they were too merciful to leave him wounded in the woods, perhaps to die of slow starvation. Bob brought him to me, and put him beside me on the floor. I looked down at him and met such a look of reproach and pathos that I gave an involuntary cry of sympathy and distress. The children gathered around me and looked at the wounded owl with sober faces. They regretted the unintentional cruelty that had brought him to this pitiful plight, but all were powerless to undo the harm that had been done. They offered him tiny bits of raw meat and several moths that had ventured in to try their wings in the gaslight, but he turned his head away and would not eat. Then cold water was held persuasively before him, but it had no charms for him and he turned those accusing eyes on first one and then another of us, until we all felt guilty and penitent.

Disappointed and remorseful the boys carried the bird out into the yard and put him high up in a cherry tree, hoping that, after all, his wounds were not serious and that by morning he would have flown away.

I got up at sunrise to add a few more gifts to the Christmas tree before the family should assemble. Out in the yard the English sparrows were chirping and scolding with even more noise than usual, and finally I went to the window to investigate.

A dozen or so of them, saucy, impertinent, defiant, were flying around the poor owl in the cherry tree. I knew without an interpreter that they were threatening, reviling and insulting him. As their chattering grew louder and angrier, other sparrows came flying from every direction until there must have been nearly 100.

The little vandals had driven away our sweet singing birds long ago, excepting an occasional mocker or oriole, and to have this big bird appear was a signal for a battle of extermination. They darted at him

with ruffled feathers and language abusive and profane. They warned him that he would be torn to pieces without mercy if he did not leave; that eating hoot owls was ordinary before breakfast fun for them; that they owned all the surrounding territory; that the British lion was their father and the American eagle their stepfather; and that he would be converted into mince-meat if he did not leave in a second.

With every threat and insult unresented, they grew bolder and fiercer, and then they began to settle down on the bare branches around him, encouraging one another to begin the attack with beak and claw, but politely declining to be the first aggressor.

Finally one sparrow, buoyed up by promises of assistance, and anxious to show the lady sparrows how brave he was, flew at the owl and gave him a sharp peck on the head.

Hitherto the owl had sat there deaf, dumb, immovable, apparently an easy victim, but as he felt that wicked blow he turned his big sun blinding eyes on his tormentors and protested with a hoarse, loud "Who-who-who-who-who-o-o-e!"

Such surprised and frightened sparrows I never saw before. They fairly fell over one another in their frantic attempts to get away from the bird monster who could talk; and for a minute afterward the air vibrated with the flutter of flying wings. Their courage, like that of many other braggarts, vanished under the stress of unknown danger, and many of them never stopped their flight till they were safe in the orchard.

The poor old owl did not follow up his victory with any more dreadful words nor even so much as the flapping of his wings. He sat there silent all day, but not a sparrow ventured near the cherry tree. They chattered and scolded and told one another they were not in the least afraid, and that as soon as they had time they would annihilate him; but they kept at a respectful distance. The owl was not disturbed until twilight, when he fell dead out of the tree, a victim of boyish thoughtlessness; and boyish hands buried him in the nasturtium bed in the garden.

### THE CANADA JAY.

During the fall and winter of last year I spent 10 weeks in the forests of Northern Wisconsin. Seven long weeks I lived alone, far from the nearest town, and at last got my fill of batching it and dough gods. About the only birds to break the silence of

the winter woods were the chickadee and the Canada jay. The latter is the most interesting and sociable bird I ever met. The name given him by science is seldom heard in the country in which he lives. A few of his many local names are "meat bird," "camp robber" and "whiskey jack." In size he is about equal to the blue jay, although appearing larger because of his thick feathers. In shape and color the camp robber is similar to the common chickadee. He lacks all song and his only note is a guttural caw. Of his nesting habits little is known, because the young are raised while snow still covers the ground.

The Canada jay is, without doubt, the boldest of our birds, and his cool impudence is amusing, if not commendable. He will boldly enter a tent occupied by several men and walk fearlessly about, helping himself freely to anything eatable. If a piece of soap be left unconcealed or if a candle chances to be overlooked by the camper it is sure to be missing if camp is left unguarded. He is not content with stealing enough for one meal, but hides all he can get in hollow trees and logs. Meat, whether raw or cooked, is his special delight, and he will work steadily carrying off and concealing it until all is taken. I once thought I would see how much one bird would carry away. I threw a piece to him as often as he came back, but after an hour had passed the supply of meat as well as my patience was exhausted.

The whiskey jack is the constant companion of the trapper, calmly riding on the edge of his canoe, where at every stroke the paddle comes within 18 inches of him. He boldly follows the woodsman to his traps and removes, if possible, the bait from deadfalls. He sits silently by while the trap is being constructed, but as soon as the owner's back is turned, swoops down with a triumphant caw and renders the trap useless by destroying the bait.

In spite of the way in which the meat bird pilfers the traps woodsmen rarely kill one, because his company helps to lessen the solitude of the woods. It is only when a man is lost in the woods without a gun that he will kill a meat bird without compunction. The way in which the cruiser kills the bird is as efficient as it is simple. If the lost man happens to have nothing to eat with him he ties a piece of his red shirt to a long light pole. This he balances on a stump, and steps behind a tree. Soon a curious camp robber will alight on the pole to investigate, whereon the cruiser hits the opposite end of the pole with a club and the shock is generally fatal to the bird.

Although the Canada jay is a tramp and steals for a living, he is a thief by necessity, for in order to live he must help himself and bountifully, too, when he has a

chance, so as to provide for a rainy day. The hardships with which he has to contend are so severe that no other bird can withstand them, and one can not help but admire his plucky fight against starvation.

Robert Montgomery, Beloit, Wis.

#### THE LOON AS IT IS NOT PICTURED.

In August RECREATION R. J. Sim asks, Who as seen a loon stand erect as they are always represented in pictures?

One morning in July, several years ago, I was climbing over some high rocks that lie off shore at Dalhousie, B. C. As I came over the crest of one, I saw below me an ungainly bird, standing erect and craning its snakelike neck. It bore little resemblance to anything I had ever seen in books or elsewhere. It stood perfectly erect and taller than one would expect even so large a bird as the great Northern diver to stand. Perceiving me it took one or two hurried waddling steps to the edge of the low rock on which it stood, fell forward and, with scarce a splash, floated gracefully on the water. Then and then only did I know it for what it was, a loon.

I once witnessed a curious piece of work in decoying a female loon. I was sitting at the edge of a lake in the Laurentian mountains of Quebec, trying to figure out the ratio of caribou absent to caribou sign abundantly present, when the monotony was varied by the appearance of a lady loon swimming around a projecting rock, and passing our temporary camp. My guide, Toby Gagnon, who had been telling me, in 16th century French, how many caribou were at the lake a week before and just why they were not there then, saw a chance to change the subject and asked if I wanted him to bring the loon in. Permission granted, he made a trumpet of his hands and uttered a peculiar note, such as I never heard before nor since from a loon, but which had an immediate effect on this particular bird. She changed her course and swam toward us. Toby repeated the call and she continued to approach, until she was within 30 yards of where we lay concealed. There she stopped and raising herself by a violent flapping of the wings, stood, as it were, erect on the water and remained so several seconds. If my memory serves me aright, for this was in '94. She gave a shrill cry in answer to the deceptive call of her supposed mate, and then sank down on the water and swam away from shore. Three times she returned to Toby's call, and repeated the performance until, disgusted apparently with the failure of her lord and master to come out of the tall timber, she went away.

E. V. Papin, Penetang, Ont.

## PROTECT THE BEAVER.

I recently returned from a trip to Indian river, the South fork of the South branch of Moose river and am surprised to learn that beavers still exist in this State. I found a white poplar, about 7 inches in diameter, nearly cut down, and fresh chips scattered at the foot of the tree. The chips could not have been made more than a week and probably not more than a few hours. Owing to the distance and the difficulty of traveling in that locality few people now visit it, and the beavers are in no immediate danger of being disturbed, but we must look farther. The lumbermen are steadily working their way back into the wilderness, and as it will be comparatively easy to float logs out into and down Moose river, it will not be long before lumbering operations will be pushed into that region and as a consequence the beavers will be crowded out. Can not something be done through RECREATION to prohibit the floating of logs down that stream, and all others known to be inhabited by beavers? It seems to me that if the true sportsmen of New York State would pull together and demand this protection for the beaver it could be obtained.

I did not have time to go down the river far enough to learn whether or not the beavers were building a dam, but the drought of early summer so lowered the streams that I have no doubt they found it necessary to commence one.

Ira L. Park, Holland Patent, N. Y.

The only method of prohibiting the running of logs in such streams as you mention would be by the enactment of a law to that effect and this would be a difficult matter. Still such a bill could be got through the Legislature if the sportsmen of the State would work actively for it. Personally, I should be glad to do everything in my power to aid in securing such legislation.

Will not some good lawyer who is interested in the preservation of the beaver draft a bill and have it introduced at Albany next winter?—EDITOR.

## NATURAL HISTORY NOTES.

In answering a question you said, in August RECREATION, that the common toad whistles but does not croak as frogs do. Whatever they do in the East, they certainly croak here, and, particularly after a rain, so loudly and persistently that they keep us awake. I know I can not be mistaken, for on one occasion while we were watching what my husband declared was a frog, my little boy waded out and caught it. It was sitting on a sunken log with its head and shoulders above water. Every now and then its throat would puff out,

and we would hear a loud croak. When brought to shore it proved to be a common toad.

Annie Beckelhyneer, Laredo, Tex.

Here is a way to poison coyotes with little danger of killing domestic animals. Any dog that will take this kind of bait deserves his dose. Every one who raises chickens has a few scrubs that he can spare. Take a live chicken, cut the feathers from the back, and rub honey in the short feathers. For poison, use strychnine, rubbing it in with the honey. Put a cord on the chicken's leg and stake it out where coyotes are likely to come. This has been tried by several people and works well.

J. E. L., Madera, Cal.

Replying to Buck Shot would say: Never put poison in the carcass where the coyotes gather, but procure some untried beef tallow, cut it in small mouthfuls, use strychnine, and put a liberal dose in each piece. Then, at 50 to 75 yards from the carcass, make a circle of baits, placing them 4 or 5 rods apart. Baits not taken should be gathered and burned. Take care to not cut tallow too large or the coyotes will not bolt the bait, consequently will detect the poison. Stubb, Orwell, O.

Does the male sparrow have a dark spot on the breast?

Is the female speckled without the brown spot on the breast?

Ralph B. Haverstick, Carnegie, Pa.

## ANSWER.

If by "sparrow" is meant the English sparrow, *Passer domesticus*. The male has the throat and foreneck black. The female lacks this and is of a uniform dirty white below. Her breast is not speckled.—EDITOR.

The domestic cat is one of the worst enemies of the rabbit. A cat belonging to a farmer at Ten Mile Run, New Jersey, brought 59 dead rabbits to the house in one season. The cook of a boat on the Delaware and Raritan canal told me that the boat cat brought 11 rabbits aboard last summer, and doubtless killed many more.

E. H. Bowne, Kingston, N. J.

Already many thousands of people are wondering what they are going to get for Christmas presents. Other thousands are wondering what they are going to give their friends. If you wish to make a present to a man or boy who is interested in shooting, fishing, amateur photography, or nature study, give him a year's subscription to RECREATION. Nothing you can possibly buy for \$1 would give him so much pleasure as 12 issues of this magazine. Come early and avoid the rush.

# THE LEAGUE OF AMERICAN SPORTSMEN.

## GENERAL OFFICERS

*President*, G. O. Shields, 23 W. 24th St., New York.

*1st Vice-President*, E. T. Seton, 80 West 40th St., New York.

*2d Vice-President*, W. T. Hornaday, 2969 Decatur Ave., Bedford Park, N. Y.

*3d Vice-President*, Dr. T. S. Palmer, Dept. of Agriculture, Washington, D. C.

*4th Vice-President*, A. A. Anderson, 80 West 40th St., New York.

*5th Vice-President*, Hon. W. A. Richards, General Land Office, Washington, D. C.

*Secretary*, A. F. Rice, 155 Pennington Ave., Passaic, N. J.

*Treasurer*, Austin Corbin, of the Corbin Banking Co., 192 Broadway, New York.

## STATE DIVISIONS

### ALASKA

Dr. E. M. Ringer, Chief Warden, Nome.

### ARIZONA

M. J. Foley, Chief Warden, Jerome.

### ARKANSAS

W. R. Blocksom, Chief Warden, Eureka Springs.

### CALIFORNIA

Dr. David Starr Jordan, Chief Warden, Leland Stanford University.

### COLORADO

A. Whitehead, Chief Warden, 303 Tabor Building, Denver.

### CONNECTICUT

Hon. F. P. Sherwood, Chief Warden, Southport; Dr. H. L. Ross, Vice-Warden, Canaan; H. C. Went, Sec.-Treas., Bridgeport.

### DISTRICT OF COLUMBIA

C. H. Townsend, Chief Warden, U. S. Fish Commission.

### FLORIDA

W. W. K. Decker, Chief Warden, Tarpon Springs.

### GEORGIA

J. J. Doughty, Chief Warden, Augusta.

### IDAHO

L. A. Kerr, Chief Warden, Kendrick.

### ILLINOIS

M. D. Ewell, M.D., Chief Warden, 59 Clark St., Chicago; F. M. Taber, Vice Warden, 144 Kinzie St., Chicago; G. C. Davis, Sec.-Treas., 123 S. Central Ave., Austin.

### INDIANA

John J. Hildebrandt, Chief Warden, Logansport; T. J. Carter, Sec.-Treas., State House, Indianapolis.

### IOWA

Carl Quimby, Chief Warden, Des Moines; C. C. Proper, Sec.-Treas., Des Moines.

### KANSAS

O. B. Stocker, Chief Warden, Wichita.

### KENTUCKY

Geo. C. Long, Chief Warden, Hopkinsville.

### MAINE

Col. E. C. Farrington, Chief Warden, Augusta.

### MARYLAND

J. E. Tylor, Chief Warden, Baltimore.

### MASSACHUSETTS

Heman S. Fay, Chief Warden, Hazleton Block, Marlboro; J. E. Tweedy, Vice-Warden, North Attleboro; A. C. Lamson, Sec.-Treas., 194 Main St., Marlboro.

### MICHIGAN

J. Elmer Pratt, Chief Warden, Grand Rapids; R. S.

Woodliffe, Vice-Warden, Jackson; A. B. Richmond, Sec.-Treas., Grand Rapids.

### MINNESOTA

Dietrich Lange, Chief Warden, 2294 Commonwealth Ave., St Paul; H. A. Morgan, Vice-Warden, Albert Lea; Prof. O. T. Denny, Sec.-Treas., St. Paul.

### MISSOURI

Bryan Snyder, Chief Warden, 726 Central Bldg., St. Louis.

### MONTANA

Professor M. J. Elrod, Chief Warden, Missoula; Sidney M. Logan, Vice-Warden, Kalispell; R. A. Wagner, Sec.-Treas., Bozeman.

### NEBRASKA

Fred. E. Mockett, Chief Warden, Lincoln; P. O'Mahony, Sec.-Treas., Lincoln.

### NEVADA

Dr. W. H. Cavell, Chief Warden, Carson; Geo. W. Cowing, Sec.-Treas., Carson.

### NEW HAMPSHIRE

Dr. A. F. Barrett, Sentinel Bldg., Keene; Sidney Conant, Sec.-Treas., Keene.

### NEW JERSEY

Percy Johnson, Chief Warden, Bloomfield; Dr. W. S. Colfax, Vice-Warden, Pompton Lakes; I. V. Dorland, Sec.-Treas., Arlington.

### NEW MEXICO

P. B. Otero, Chief Warden, Santa Fe.

### NEW YORK

John R. Fanning, Chief Warden, Powers' Bldg., Rochester; Col. R. E. Moss, Vice-Warden, Wallack's Theatre, New York City; Dr. C. C. Curtis, Sec.-Treas., Columbia College, New York City.

### NORTH DAKOTA

Dr. W. D. Jones, Chief Warden, Devil's Lake.

### OHIO

W. E. Gleason, Chief Warden, Mitchell Bldg., Cincinnati; A. C. Thatcher, Vice-Warden, Urbana.

### OKLAHOMA

W. M. Grant, Chief Warden, Oklahoma City.

### ONTARIO

C. A. Hammond, Chief Warden, Box 701, St. Thomas; D. L. Mells, Sec.-Treas., St. Thomas.

### OREGON

Robert F. Kelly, Chief Warden, Box 188, The Dalles; C. B. Cushing, Sec.-Treas., The Dalles.

### PENNSYLVANIA

C. F. Emerson, Chief Warden, 189 N. Perry St., Titusville; Hon. C. B. Penrose, Vice-Warden, 1720 Spruce St., Philadelphia.

### RHODE ISLAND

Zenas W. Bliss, Chief Warden, 49 Westminster St., Providence.

### SOUTH CAROLINA

C. F. Dill, Chief Warden, Greenville.

### SOUTH DAKOTA

D. C. Booth, Chief Warden, Spearfish; John C. Barber, Sec.-Treas., Lead.

### TENNESSEE

Hon. G. C. Martin, Chief Warden, Clarksville; Hon. Austin Peay, Jr., Sec.-Treas., Clarksville.

### TEXAS

Prof. S. W. Stanfield, Chief Warden, San Marcos; W. E. Heald, Sec.-Treas., San Angelo.

### UTAH

Hon. John Sharp, Chief Warden, Salt Lake City.

### VERMONT

S. C. White, Sec.-Treas., Woodstock.

### VIRGINIA

R. G. Bickford, Chief Warden, Newport News. C. O. Saville, Vice-Warden, Richmond; M. D. Hart, Sec.-Treas., 1217 East Main St., Richmond.

### WASHINGTON

F. S. Merrill, Chief Warden, Spokane; F. A. Pontius, Sec.-Treas., Seattle; Munro Wyckoff, Vice-Warden, Pt. Townsend.

WEST VIRGINIA.

E. F. Smith, Chief Warden, Hinton,

WISCONSIN.

Frank Kaufman, Chief Warden, Two Rivers; Dr. A. Gropper, Sec.-Treas., Milwaukee.

WYOMING.

H. E. Wadsworth, Chief Warden, Lander; Frank Bond, Sec.-Treas., Cheyenne.

*Applications for membership and orders for badges should be addressed to Arthur F. Rice, Secretary, 23 W. 24th St., New York.*

LOCAL WARDENS

CONNECTICUT.

County.	Name of Warden.	Address.
Fairfield,	George B. Bliss.	2 Park Row, Stamford.
"	Harvey C. Went,	11 Park St., Bridgeport.
"	Samuel Waklee,	Box 373, Stratford.
Litchfield,	Dr. H. L. Ross,	P. O. Box 100, Canaan.
Middlesex,	Sandford Brainerd,	Ivoryton.
New Haven,	Wilbur E. Beach,	318 Chapel Street, New Haven.
"	D. J. Ryan,	188 Elizabeth St., Derby.

FLORIDA.

Brevard, C. H. Racey, Waveland.

ILLINOIS.

Iroquois, J. L. Peacock, Sheldon.  
Rock Island, D. M. Slottard, 12th Ave. and 17th St., Moline.

IOWA.

Clinton, D. L. Pascol, Grand Mound.  
Pottawattamie, Dr. C. Engel, Crescent.

KANSAS.

Ness, Frank Lake, Ransom.

MASSACHUSETTS.

Norfolk, Orlando McKenzie, Norfolk.  
" J. J. Blick, Wrentham.  
" S. W. Fuller, East Milton.  
Suffolk, Capt. W. J. Stone, 4 Tremont Row, Boston.  
Worcester, B. H. Mosher, Athol.

MICHIGAN.

Berrien, W. A. Palmer, Buchanan.  
Cass, Thomas Dewey, Dowagiac.  
Hillsdale, C. A. Stone, Hillsdale.  
Kalamazoo, C. E. Miller, Augusta.  
Lake, John Trieber, Peacock.  
Ottawa, W. H. Dunham, Spencer.

NEBRASKA.

Hall, E. C. Statler, Grand Island

NEW HAMPSHIRE.

Cheshire, S. C. Ellis, Keene.  
Sullivan, G. A. Blake, Lempster.  
" J. W. Davidson, Charlestown.

NEW JERSEY.

Hudson, A. W. Letts, 51 Newark St., Hoboken  
Mercer, Edw. Vanderbilt, Dentzville, Trenton.  
" Roland Mitchell, 739 Centre St., Trenton  
" F. C. Wright, Trenton.  
Monmouth, Dory-Hunt, Wanaque.  
Morris, Joseph Pellet, Pompton Plains.  
" Chas. W. Blake, Dover.  
" Francis E. Cook, Butler.  
" Calone Orr, Hibernia.  
Somerset, G. E. Morris, Somerville.  
Sussex, Isaac D. Williams, Branhville.  
Union, A. H. Miller, Cranford.  
" C. M. Hawkins, Roselle.  
Warren, Jacob Young, Phillipsburg.  
" Reuben Warner,

NEW YORK.

Albany, C. D. Johnson, Newtonville.  
" Kenneth E. Bender, Albany.  
Allegany, G. A. Thomas, Belvidere.

County.	Name of Warden.	Address.
Broome,	John Sullivan,	Sanitaria Springs
"	R. R. Mathewson,	Binghamton.
Cayuga,	H. M. Haskell,	Weedsport.
Chemung,	Fred. Uhle,	Hendy Creek,
"	M. A. Baker,	Elmira.
Columbia,	A. B. Miller,	Jackson's Corners
Cortland,	James Edwards,	Cortland,
Dutchess,	A. B. Miller,	Jackson's Corners.
"	Chas. H. DeLong,	Pawling.
"	Jacob Tompkins,	Billings.
Erie,	Marvin H. Butler,	Morilla.
Essex,	W. H. Broughton,	Moriah.
Franklin,	Jas. Eccles,	St. Regis Falls.
Greene,	W. J. Soper,	Windham.
Hamilton,	David Aird, Jr.,	Lake Pleasant.
Herkimer,	D. F. Sperry,	Old Forge.
Jefferson,	C. J. Smith,	Watertown.
"	A. C. Cornwall,	Alexandria Bay,
"	Jos. Northrup,	"
Livingston	M. De La Vergne,	Lakeville.
"	K. S. Chamberlain,	Mt. Morris.
"	Henry Skinner,	Springwater.
"	Dr. J. W. Cowan,	Geneseo.
Montgomery,	Charles W. Scharf,	Canajoharie.
New York,	C. L. Meyer,	46 W. B'way, N.Y. City.
Oneida,	J. M. Scoville,	Clinton.
Onondaga,	James Lush,	Memphis.
Orange,	Wilson Crans,	Middletown.
"	J. Hampton Kidd,	Newburgh.
"	Thomas Harris,	Port Jervis.
Orleans,	J. H. Fearby,	E. Shelby.
Oswego,	J. E. Manning,	154 West Utica St. Oswego.
Putnam,	H. L. Brady,	Mahopac Falls.
Queens,	Gerard Van Nostrand,	Flushing, L. I.
"	W. S. Mygrant,	46 Elton Street, Brooklyn.
"	P. A. Geepel,	473 Grand Ave., Astoria, L. I.
"	L. B. Drowne,	119 Somers Street, Brooklyn.
"	Lewis C. Att,	Broad Channel Hotel, Rockaway, L. I.
Richmond.	Lewis Morris,	Port Richmond.
St. Lawrence,	Dr. B. W. Severance,	Gouverneur.
"	A. N. Clark,	Sevey.
Schenectady,	J. W. Furnside,	Schenectady.
Schoharie,	O. E. Eigen,	Sharon Springs.
Schuyler,	G. C. Fordham,	Watkins.
Suffolk,	F. J. Fellows,	Central Islip, L. I.
"	P. F. Tabor,	Orient, L. I.
Tioga,	Geo. Wood,	Owego.
Ulster,	M. A. DeVall,	The Corners.
"	Wm. S. Mead,	Woodstock.
Warren,	Geo. McEchron,	Glens Falls.
Washington,	C. L. Allen,	Sandy Hill.
"	J. E. Barber,	Dresden.
"	A. S. Temple,	Whitehall.
Westchester,	George Poth,	Pleasantville.
"	Chas. Seacor,	57 Pelham Road, New Rochelle.
"	M. W. Smith,	Croton Falls.
"	Ralph Gorham,	Mt. Kisco.
Yates,	B. L. Wren,	Penn Yan.
"	Seymour Poineer,	Branch Port.

OHIO.

Allen, S. W. Knisely, Lima.  
Clark, Fred C. Ross, 169 W. Main St., Springfield.  
Cuyahoga, A. W. Hitch, 161 Osborn St., Cleveland.  
Erie, David Sutton, 418 Jackson St., Sandusky.  
Franklin, Brook L. Terry, 208 Woodward Av., Columbus.  
Fulton, L. C. Berry, Swanton.  
Hamilton, W. C. Rippey, 4465 Eastern Ave., Cincinnati.  
Knox, Grant Phillips, Mt. Vernon.  
Lorain, T. J. Bates, Elyria.  
Muskingum, Frank D. Abell, Zanesville.  
Ottawa, Frank B. Shirley, Lakeside.  
Scioto, J. F. Kelley, Portsmouth.  
Stark, A. Dangeleisen, Massillon.

OKLAHOMA.

Kiowa and Comanche Nation, A. C. Cooper, Ft. Sill.

## PENNSYLVANIA.

County.	Name of Warden.	Address.	
Allegheny,	S. H. Allen,	Natrona.	Austin, Pa.,
Beaver,	N. H. Covert,	Beaver Falls.	Boston, Mass.,
	W. R. Keefer,	"	Buffalo, N. Y.,
Bradford,	Geo. B. Loop,	Sayre.	Cammal, Pa.,
Butler,	F. J. Forquer,	Murrinsville.	Champaign Co., O.
Cambria,	W. H. Lambert,	720 Coleman Ave.,	Urbana,
		Johnstown.	Charlestown, N. H.,
Cameron,	Harry Hemphill,	Emporium.	W. M. Buswell,
Carbon,	Asa D. Hontz,	East Mauch Chunk.	J. Hennessy,
Clarion,	Isaac Keener,	New Bethlehem.	Choteau, Mont.,
Clinton,	M. C. Kepler,	Renovo.	G. A. Gorham,
"	Geo. L. Kepler,	"	Cincinnati, Ohio,
"	R. T. Antes,	Pine Station	B. W. Morris,
Crawford,	Jasper Tillotson,	Tillotson.	Coudersport, Pa.,
"	Geo. T. Meyers,	Titusville.	Cresco, Iowa,
"	J. B. Lamb,	Buel.	Cross Village, Mich.,
Cumberland,	J. C. Gill,	Mechanicsburg.	Davis, W. Va.,
Delaware,	Walter Lusson,	Ardmore.	Dowagiac, Mich.,
Elk,	D. R. Lobaugh,	Ridgway.	East Mauch Chunk, Pa.,
Fayette,	Ely Cope,	Cadwallader.	E. F. Fry,
Jefferson,	John Noll,	Sykesville.	Evansville, Ind.,
Juniata,	Clifford Singer,	Oakland Mills.	Fontanet, Ind.,
"	Ezra Phillips,	McAlesterville.	Ft. Wayne, Ind.,
Lackawanna,	Wm. Weir,	Moosic.	Great Falls, Mont.,
"	Wm. Major,	"	Heron Lake, Minn.,
Lycoming,	Jas. J. Brennan,	Oval.	Hollidays'bg, Pa.,
"	B. D. Kurtz,	Cammal.	Hopkinsville, Ky.,
McKean,	C. A. Duke,	Duke Center.	Indianapolis, Ind.,
"	L. P. Fessenden,	Granere.	Jerome, Ariz.,
"	Wm. Holsinger,	Stickney.	Johnsonburg, Pa.,
Montgomery,	L. C. Parsons,	Academy.	Kalispell, Mont.,
Northumber-	G. W. Roher,		Keene, N. H.,
land,	505 Anthracite St.,	Shamokin.	Kingfisher, Okla.,
Perry,	Samuel Sundy,	Lebo.	Lake Co., Ind.,
Potter,	Ira Murphy,	Coudersport.	Lawton, O. T.,
"	Wiley Barrows,	Austin.	Lincoln, Neb.,
"	Chas. Barrows,	Austin.	Logansport, Ind.,
Tioga,	E. B. Beaumont, Jr.,	Lawrenceville	Ludington, Mich.,
"	G. H. Simmons,	Westfield.	McElhattan, Pa.,
Venango,	G. D. Benedict,	Pleasantville.	Mechanicsburg, Pa.,
Warren.	F. P. Sweet,	Goodwill Hill.	Minturn, Colo.,
	Nelson Holmes,	Cornplanter.	Morgantown, W. Va.,
Wyoming,	Cyrus Walter,	Tunkhannock.	New Albany, Ind.,
			New Bethlehem, Pa.,
			Oklahoma City O. T.,
			Penn Yan, N. Y.,
			Phillips, Wis.,
			Princeton, Ind.,
			Reynoldsville, Pa.,
			Ridgway, Pa.,
			Rochester, N. H.,
			" N. Y.,
			St. Paul, Minn.,
			St. Thomas, Ont.,
			Schenectady, N. Y.,
			Seattle, Wash.,
			Syracuse, N. Y.,
			Terre Haute, Ind.,
			The Dalles, Ore.,
			Walden, N. Y.,
			Wichita, Kas.,
			Winona, Minn.,
			W. S. Warner,
			Capt. W. I. Stone,
			H. C. Gardiner,
			B. A. Ovenshire,
			Hy. F. MacCracken
			Rear Warden.

## TENNESSEE.

Madison,	H. T. Rushing,	Jackson.
Montgomery,	P. W. Humphrey,	Clarksville.
Robertson,	C. C. Bell,	Springfield.
Stewart,	John H. Lory,	Bear Spring.
Sumner,	W. G. Harris,	Gallatin.

## UTAH.

Washington,	S. C. Goddard,	New Harmony.
"	J. A. Thornton,	Pinto.

## VERMONT.

Essex,	H. S. Lund,	Granby.
Orleans,	E. G. Moulton,	Derby Line.
Rutland,	Wm. J. Liddle,	Box 281, Fair Haven
Windsor,	F. A. Tarbell,	West Bridgewater.

## VIRGINIA.

Henrico,	W. J. Lynham,	412 W. Marshall,
		Richmond.
King & Queen,	R. D. Bates,	Newtown.
King William,	N. H. Montague,	Palls.
Louisa,	J. P. Harris,	Applegrove.
Mecklenburg,	J. H. Ogburn,	South Hill.
Smythe,	J. M. Hughes,	Chatham Hill.

## WASHINGTON.

Okanogan,	James West,	Methow.
Stevens,	Jacob Martin,	Newport.
"	L. H. Lee,	Northport.
Yakima,	J. Brachmann,	N. Yakima.

## WYOMING.

Carbon,	Kirk Dyer,	Medicine Bow.
Fremont,	Nelson Yarnall,	Dubois.
Laramie,	Martin Breither,	Cheyenne.
Uinta,	{ S. N. Leek,	} Jackson.
	{ F. L. Peterson,	

## LOCAL CHAPTERS.

Albert Lea, Minn.,	H. A. Morgan,	Rear Warden.
Anadarka, O. T.,	Bert Smith,	"
Angelica, N. Y.,	C. A. Lathrop,	"
Augusta, Mont.,	H. Sherman,	"
Austin, Minn.,	G. F. Baird,	"

## LIFE MEMBERS OF THE LEAGUE.

Anderson, A. A.,	80 W. 40th St.,	New York City.
Beard, D. C.,	204 Amity St.,	Flushing, L. I.
Blackstone, Lorenzo,	Norwich,	Conn.
Brown, J. Stanford,	489 Fifth Ave.,	New York City.
Butler, C. E.,	Jerome, Ariz.	
Carey, Hon. H. W.,	Eastlake, Mich.	
Carnegie, Andrew,	2d, Fernandina,	Fla.
Carnegie, George,	Fernandina,	Fla.
Carnegie, Morris,	Fernandina,	Fla.
Corbin, Austin,	192 Broadway,	New York City.
Dickinson, E. H.,	Moosehead Lake,	Me.
Edgell, G. S.,	192 Broadway,	New York City.
Ellis, W. D.,	136 W. 72d St.,	New York City.
Fearing, D. B.,	Newport,	R. I.
Ferry, C. H.,	1720 Old Colony Bldg.,	Chicago, Ill.
Ferry, Mansfield,	183 Lincoln Park Boulevard,	Chicago, Ill.
Fraser, A. V.,	478 Greenwich St.,	New York City.
Gilbert, Clinton,	2 Wall St.,	New York City.
Hudson, E. J.,	33 E. 35th St.,	Bayonne, N. J.
McClure, A. J.,	158 State St.,	Albany, N. Y.
Mershon, W. B.,	Saginaw,	Mich.
Miller, F. G.,	108 Clinton St.,	Defiance, O.
Morton, Hon. Levi P.,	681 Fifth Ave.,	New York City.
Nesbitt, A. G.,	Maple St.,	Kingston, Pa.

O'Connor, Col. J. C., 24 E. 33d St., New York City.  
 Pierson, Gen. J. F., 20 W. 52d St., New York City.  
 Prescott, A. L., 90 W. Broadway, New York City.  
 Rice, A. F., 155 Pennington Ave., Passaic, N. J.  
 Seton, E. T., 80 W. 40th St., New York City.  
 Seymour, J. H., 35 Wall St., New York City.  
 Smith, E. B., Bourse Bldg., Philadelphia, Pa.  
 Smith, W. H., Bryn Mawr, Pa.  
 Thompson, J. Walter, Times Bldg., New York City.  
 Towne, E. S., Care of National Blank Book Co., Holyoke, Mass.  
 Underwood, W. L., 52 Fulton St., Boston, Mass.  
 Valentine, Dr. W. A., 5 W. 35th St., New York City.  
 H. Williams, Box 156, Butte, Mont.

#### DISCOUNTS TO LEAGUE MEMBERS.

The following firms have agreed to give members of the L. A. S. a discount of 2 per cent. to 10 per cent. on all goods bought of them. In ordering please give L. A. S. number:

Syracuse Arms Co., Syracuse, N. Y. Guns.  
 Davenport Fire Arms Co., Norwich, Conn. Shot guns, rifles.  
 Gundlach Optical Co., Rochester, N. Y. Photographic goods.  
 Blair Camera Co., Rochester, N. Y. Photographic goods  
 James Acheson, Talbot St., St. Thomas, Ontario, Sporting goods.

#### THESE ARE NOT QUITTERS.

We are still actively engaged in protecting game and fish. Three years ago the game and fish laws were flagrantly violated all over the county. Now we have practically broken up illegal hunting and fishing. On Labor Day I made a trip through one of our best game districts and did not see a single hunter or hear a shot fired. A few years since on Labor Day, in the same section, there was a regular fusillade, from morning till night. We posted the county again this year with L. A. S. posters, and with fish notices, that we had printed.

The arrest of Italians made on Thursday for dynamiting the river was a great victory, as they were the first foreigners to be arrested in this county. It will be an example to the hordes of their countrymen who are working on railroads and quarries around here. This arrest was planned and carried out by our Secretary, William Gardner, who also led the posse which captured the men in their shanty.

I forgot to thank you for the able assistance you gave us in the work of crushing the new squirrel bill, which came up before the Legislature last spring. The measure was to change the open season, which now begins October 15, to September 15. If it had not been for the powerful opposition made by the League, the bill would have easily passed.

A bill was passed which requires unnaturalized foreigners to pay a license of \$10 for the privilege of hunting, and we intend to enforce this law to the letter.

Have notified the bosses to explain the law to the men and to warn them not to break it. This has had the desired effect in several camps. I notice that game is much more plentiful this year, and I can see no reason why it should not become abundant in a short time, if the work of protecting it is continued.

Harry P. Hays, Hollidaysburg, Pa.

The Blair county members of the League are stayers. It is indeed gratifying to find some men in every community whose interest in game protection is permanent. I could name hundreds of sportsmen who a few years ago were active in the work, but their interest was short lived, and they are now never heard of in this connection. I like a man who when he puts his hand to the plow, never looks back; who when he joins the League and starts in to help save the game, keeps at it until he dies. There are a few men who have been active on these lines 15 to 25 years, but for every one such, there are a hundred, perhaps a thousand, who no longer care whether the game is saved or exterminated. All honor to the men who keep everlastingly at it.—  
 EDITOR.

#### A RICH MAN'S OPPORTUNITY.

What a great benefit could any of the millionaires, Carnegie, Gould, Vanderbilt, or others, confer on humanity by creating a trust fund of a million dollars, the income to be used for the preservation of our game and song birds, and forests! Surely the public good that would result from such a fund would more than repay the donor. Such an act would be heralded to every corner of the United States. The influence of such an act could not be overestimated as it would create a feeling of respect and duty in the minds of everybody, and the object lesson would eventually influence the whole world. The donor would be blessed by the generations which follow ours, to an extent that can only be appreciated in this day by the many sportsmen RECREATION has helped to make. I trust this subject may be properly brought to the notice of those who are able to create such a fund.

L. A. S., No. 2221, Dayton, Ohio.

A circular letter was sent out from this office, a year ago, to 4,500 millionaires, including those you mention, asking for contributions to the game protective fund of the L. A. S. About 40 checks were received, aggregating \$773. The appeal should have brought a much larger sum, and it is hoped that as the League grows older, and its work becomes better known to wealthy philanthropists, some of them may decide to make substantial donations to its working fund.—EDITOR.

## YOU SHOULD BE THERE.

The 6th annual meeting of the League will be held in Columbus, Ohio, Wednesday, February 10, 1904, and from present indications it will be the greatest and most successful gathering of any yet held. Chief Warden Gleason and Vice-Warden Thatcher, of the Ohio Division, together with the Hon. J. C. Porterfield, Chief Warden of the State Game and Fish Commission, are working like Trojans toward that end. These men are known throughout Ohio as thorough sportsmen and enthusiastic workers in the cause of game protection, and there is abundant reason to believe that the sportsmen of Ohio will respond generously and liberally to their efforts in this matter.

Every officer of the League should begin now to make arrangements to attend the 6th annual meeting. The 4th and 5th annual gatherings were great events and the men who attended them will tell you that all who were not there missed rare treats. No officer should deprive himself of the pleasure and the benefit to be derived from attending this 6th annual meeting, and I hope to see a greater gathering this year than ever before.

## LEAGUE NOTES.

Local Warden A. C. Cooper, of Fort Still, O. T., has done a great deal of valuable work in his district in the interest of game and fish protection. One of his important efforts has been in restocking Cache creek, a tributary of Red river, with game fishes. Some months ago, Mr. Cooper made application to the U. S. Fish Commission for 28,000 crappies to be planted in Cache creek, and the request was granted. Local sportsmen are requested to refrain from taking any of these fishes from that stream during the next 2 years, and if this reasonable suggestion is generally complied with, there can be little doubt that Cache creek will be abundantly supplied with crappies by the end of that time.

Warden Cooper recently arrested 2 men for taking fish from Cache creek with a hoop net, but they escaped punishment in that case on a technicality. He is still after their scalps and will undoubtedly get them later.

Stamford, Conn.

Mr. F. P. Sherwood, Chief Warden,  
Southport, Conn.

Dear Sir: Complaint was made to me yesterday against Italians shooting robins. I sent the deputy sheriff to Springdale and he captured 4 men, 4 guns, 4 robins, and one blue jay. One fellow had nothing and they let him go. The other 3 were taken before the prosecuting attorney and pleaded guilty. Case was settled by 2 of the men paying \$15 each and the one-bird man \$10,

total \$40. This was satisfactory to me as complainant. All were of the same opinion, that they "no more shoot; \$8 a bird too much."

G. B. Bliss, Local Warden.

The first case under the new game laws in the police court of Hollywood, N. J., was that of Samuel L. Cousins, charged with having captured 2 mockingbirds and carried them from their nests. W. J. Lynham swore out the warrant. As it was a first offense the justice fined Cousins only \$2, but stated that the next time a man should be taken before him here on a charge of that sort he would get the maximum punishment.—New Jersey paper.

I am sorry I can not give the name of this Justice of the Peace. He is a righteous judge and deserves a better position than that of Justice of the Peace. Both he and Warden Lynham have established an excellent school in their district and all would be lawbreakers may learn wisdom therefrom. Mr. Lynham is an L. A. S. warden.  
—EDITOR.

## MEMORIES.

ETTIE A. DAY.

My father was a Mandan chief

And, years ago, the prairie ruled;  
His braves, like all the Indian race,  
In war and in the chase were schooled.

My childhood home was anywhere  
My father's band might choose to stay;  
Their houses were but skin tepees,  
Their beds, the ground whereon they lay.

Our cook stove was the camp fire coals,  
Our only lamp, the camp fire glow;  
My cradle was a fawn skin bag  
That from a tree swung to and fro.

One day my father said to me,  
"The great white chief has made a rule  
That you and all the Indian boys  
Must leave their homes and go to  
school."

So I bade farewell to parents,  
To birds, to flowers, to grass and trees,  
To the home where I was care free,  
With no one but myself to please.

And since then I've grown stout and tall,  
For that was many years ago;  
I've learned to live as white men live  
Although I find it very slow.

There will always be a longing,  
Deep hidden in my brawny breast,  
For my dear lost old tepee home  
And the prairie wilds I love the best.

Two colored women met on the corner  
and the following dialogue took place:

"Hullo, Liz! Wha' yo' gwine?"  
"I ain't gwine no wha'; I'se jes' bin wha'  
I'se gwine."—C. H. and D. Magazine.



# FORESTRY.

EDITED BY DR. B. E. FERNOW.

It takes 30 years to grow a tree and 30 minutes to cut it down and destroy it.

## FORESTRY MEETINGS.

For 20 years conventions have been held in the United States at which the need of forest preservation and the methods of securing it have been discussed.

The first one was the meeting in Cincinnati, April, 1882, of the American Forestry Congress, an impressive affair, lasting 5 days, the city in bunting, orators at all street corners and finally a parade of 60,000 school children marching out to Eden Park and planting memorial trees.

This first gathering was also the largest and most pretentious. After that the few persons who remained faithful, found it often difficult to fill a decent hall with listeners; but lately not only the number who go to such forestry meetings but the character of the attendance has improved. At the last summer meeting of the American Forestry Association, at Minneapolis, in August, 200 people found it interesting to stay through 2 days' sessions. The most interesting feature of the meeting was the presence of a number of substantial lumbermen, who participated actively in the proceedings. At last the inevitable seems to have arrived, namely that lumbermen and forestry propagandists come together. Professional foresters had, of course, always known that without their assistance the lumber business must ultimately collapse; but lumbermen had been always in doubt. The majority probably have not yet awakened to the relationship between lumbering and forestry, and forestry reformers of the Arbor day type have helped to deter the lumbermen from this recognition.

The attitude that formerly existed and the new attitude were clearly indicated by Mr. B. F. Nelson, a prominent lumberman of the Northwest. He said:

"The lumbermen of to-day are often bitterly denounced as the vandals of the forest. They are charged with the ruthless destruction of virgin timber at the expense of future generations. They have had curses heaped on their heads by persons who charge them with making money by methods which are without economic or moral excuse.

"Lumbermen resent such criticism, as they do not feel that their vocation is without moral excuse or reason. There has been abundant excuse for the destruction of the forests. The forest was the natural enemy of our forefathers, and without its destruction our land could not have been settled and advanced as it is to-day. The

forests had to be sacrificed that the great prairies might be won. While the forests have been converted into lumber, which is indispensable to our well being, great areas of denuded timber lands have become available for the tilling of the soil.

"The lumbermen are as willing as most persons to deplore the ravaging of the forest, but they do not believe themselves any more responsible for it than for the conditions of society which demand it. They are naturally in favor of reforestation wherever practicable, because of the many beneficent influences accruing therefrom, in the effect of forests on the flow of streams, on winds and temperature and on the general prosperity and welfare of the nation.

"The greater part of the land from which the timber has been removed in the Northern pine belt is much more valuable and suitable for cultivation than for reforestation. The growth of timber is so slow that the present generation can not be expected to replant timber lands for the financial benefits which they might derive therefrom. This is especially true when the profits likely to be obtained from their lands, after a period of 60 or 80 years, will be largely reduced by the taxes which they will have paid during that time, and the results are uncertain because of fires and other enemies of the forest."

One of the best known lumbermen of Minnesota, now largely interested on the Pacific coast, Mr. T. B. Walker, committed himself thoroughly to the need of a forest policy and added many valuable practical suggestions in a paper from which the following extracts are taken:

"At the present rate of consumption, the timber now standing will be consumed within 35 years, so that in the near future, substitutes for wood, curtailed consumption, better forestry methods, and reproduction will be necessitated. Forests are all in sight and subject to general estimates differing materially from iron, coal, oil, building stone, etc., where the supply is under cover and the extent unknown but practically inexhaustible.

"The responsibility of lumbermen for wasteful methods should rest equally on the public and on the government. Our vast hard wood forests have been cut away and in large part burned in log heaps by the pioneer settlers in clearing their lands for cultivation. National, State and county governments have authorized and protected all frontier settlers and loggers in wasting

our forests. Homestead law and pre-emption and timber and stone acts and the land sales in 40 acre tracts at public auction have scattered the ownership of timber lands. Lumbermen could not secure sufficient areas of timber to make economical logging operations or apply proper forestry methods.

"For buying lands of entrymen, lumbermen have been censured and criticised, though that is what the laws undoubtedly anticipated. Violations of the laws are exceptions, not the rule. Premature county organizations and heavy taxes on unproductive land where owners were non-residents and derived no benefit from the tax, have aided in denuding the forests, to escape this burden. When lands in our pine-ries were denuded of timber they were wanted for cultivation, which fact has made counties, State and Nation more indifferent as to the preservation of forests. Methods of disposing of public timber lands have placed lumbermen at great disadvantage. Economical methods could not be applied to scattered tracts. The Canadian system of large limits and light taxes has given Canadians great advantages.

"In the Western forests, conditions are much more favorable, better forestry methods can be adopted, more practicable and profitable and continued supply of timber can be produced. Protection against fire can be successfully applied by clearing away all dry materials from around each of the trees. Large trees may be cut, leaving much greater numbers of smaller trees for growth and reforestation. As the lands are not valuable for agricultural purposes, taxes will be made light on partially cut lands, so that continued growth can be maintained. Protecting forests by attempting to keep the fires from running is not a success. When fires are kept from running for long periods, damage, when it does run, is greater than the aggregate of intermediate burnings, and fires can not be entirely prevented.

"Timber permits by government should be on a large scale to make logging and reforestation profitable and economical. A large proportion of our lumber supply in later years must come from private timber cultivation on individual holdings.

"The forestry department will become increasingly more and more important. It should be given large authority, and means to carry on the work and for reforestation on a large scale as rapidly as may prove practicable."

There is a great deal of common sense in these explanations of the difficulties which have forced lumbermen to uneconomical methods and, no doubt, in the end the people alone are to be blamed for the ruthless forest destruction; for the people

have always had it in their power to remove these difficulties, provided this be, as it is claimed, a government of the people, by the people, for the people!

There are, of course, lumbermen, who do not look so liberally on the establishment of forest policies by the States as Mr. Walker does. This came out when a paper was read on the effect of the Chippewa Forest Reserve on the locality. The writer claimed that certain jack pine lands with sandy subsoils were agriculturally valueless and would be more profitable in forest. Some owners of cut over lands of that character contended that the lands were still good enough for settlers, to whom the lumbermen owners would rather dispose of them, than to have the State take them for wood-cropping.

The same divergence of interests has made itself felt in Michigan, where the farmers object to forest reservations, because the tax burden is thereby less distributed. Prof. F. Roth, of the University of Michigan, in charge of the new College of Forestry, referred to this in his paper on the possibilities and methods of reforestation in the white pine belt:

"Our methods of using the pine forests have left us large areas of denuded lands, considerable portions of which are in a burned or fire-scarred, waste condition. Reforestation concerns itself with putting these unproductive non-agricultural lands back into a productive condition. Unfortunately the opinions concerning these lands vary within wide limits, and consequently there is much disagreement as to what can and what should really be done with them. Naturally the local town and county officials, the county papers and many, not all, of the citizens, desire their town and county to be built up, to get taxpayers, roads and schools and incidentally to have the value of their holdings increased. These people mean well and deserve careful consideration. Less so the mere speculator in these cheap waste lands, who makes a business of persuading good, thrifty laborers and artisans from the city into buying sand lands, and thereby gets the least experienced and most poorly equipped people to undertake what the most experienced farmer refuses to try. These settlers generally fail, and the last 50 years' experience in Wisconsin and Michigan, as well as on the large stretches of sands along the Atlantic, clearly proves this fact. The evidence of these people, therefore, is biased and makes these lands appear better than they are. Census figures on settlement and improved lands indicate that the sandy lands in our lake States, formerly pinery and now largely waste lands, have remained unsettled; that, for instance, the State of Michigan has 16

counties in the Southern Peninsula which average but 6 per cent of improved land. The same census reports show that the older States, too, have their waste lands; that Maine has still 88 per cent. of her lands not tilled, Pennsylvania 55 per cent, Virginia 61 per cent., and even Massachusetts 77 per cent. The experience of Europe, extending ing back for centuries, fully corroborates the general truth that there are few countries which have not a large proportion of land unfit for agriculture. Unproductive lands are a waste, a loss. For this reason the Old World States, for centuries, have endeavored to keep these lands in the hands of the State and keep or make them productive through forestry methods. In recent years the States of New York, Pennsylvania, and lately the State of Wisconsin have decided to abandon the policy of getting rid of tax title and other State lands, and to take the poor lands of the State and improve them along forestry lines. In our white pine belt there is much of this work to be done. As to methods there are many. Wherever a growth of young trees exists it may often be best merely to protect and wait and let Nature do the work. In many cases this will be too slow, fires have cleaned up completely, there are no trees to produce seed, and the young tree growth has all disappeared. In such cases replanting will be economy. Among the trees to plant, the native trees, white pine, Norway and jack pine, will deserve first choice, but others may be tried. Planting from nurseries kept right on the ground will probably be the cheapest method in the end. What this leads to may be summed up briefly: It will mean millions of acres of productive woods where now there is nothing but unproductive waste; it will mean permanent mills and factories, employment for permanent people, not nomads, and a sorely needed home supply of one of the most necessary products used in civilized life."

The question of taxing woodlands has been again raised. At present it is unjustly handled and in such a manner as to be a premium on forest destruction. Mr. Ernest Bruncken, in his paper on Taxation and Private Forestry, contended that the prevailing practice of taxing all merchantable timber annually, regardless of whether it was to be harvested during the current year or not, was a premium on cutting timber which, though merchantable, had not yet reached its highest value. The loss fell far more on the community than on the owner.

As possible remedies were suggested: Exemption of timber while taxing the land on its agricultural value, which was dismissed as impracticable; Taxing the land at its agricultural value, exempting the timber from the property tax, but exacting a tax on the gross income derived by the owner

from the sale of the timber. This was declared a fair and feasible solution of the problem. The speaker proposed a plan by which he hoped both to solve the taxation difficulty and to offer an inducement to woodland owners to manage their woodlands according to forestry methods. He would permit owners of timber land to register with the State Forest Department, and agree to manage them according to working plans adopted with the assistance of the department, and under its supervision. In return the land would be assessed by the department instead of by the local assessors, at what it would be worth for permanent forest instead of agricultural land, while the timber would be assessed only in the year in which it is actually cut.

Dr. Fernow spoke at length of the difficulties of devising practicable tax laws and the insufficiency of the existing laws intended to encourage private forestry in Indiana and Pennsylvania.

The need for educated foresters to carry out reforestation plans was brought out by Prof. T. B. Green, of the Minnesota Agricultural College, contending that the agricultural colleges are best fitted to train foresters.

These colleges now aim to train men to see the possibilities of rural life, and the forester needs much the same training, for he will probably spend his life in rural communities where he will be thrown largely on his own resources in dealing with thousands of natural problems at first hand. He will have charge, perhaps, of a forest that contains a considerable extent of farm or pasture lands, and he should understand the best method of developing them.

Much time was naturally consumed in discussions having reference to the new federal Minnesota forest reservation at Cass lake and the Itaska Park State reservation.

Dr. Fernow finally pointed out the nearest duty for the Forestry Association: Referring to the fact that the Forestry Association met in the twin city of St. Paul just 20 years ago for its third meeting, he reviewed briefly the changes that had taken place since that time, both in regard to consumption and supply of forest products and in regard to the progress of the forestry movement:

"From the census statistics, it appears that the timber industry in these 20 years has more than trebled in the capital employed, namely to over 600 million dollars, and the value as well as the quantity of product has more than doubled, while the population has increased little over 50 per cent. In other words, the tendency is to constantly increase the use of wood and the drafts on our timber reserves in excess

of the increase in population. The danger of exhausting our timber supplies before they can be replaced is infinitely greater now than it was 20 years ago, hence the efforts to secure their replacement must be also much greater. In spite of the heroic efforts of the Federal Government to induce private owners to adopt a more conservative management of timber lands, in spite of the extension of the forest reservation policy, in spite of the beginnings of a forest policy in several States, these efforts are still embryonic and nowhere in proportion to the magnitude of the interests involved. The Eastern wooded States in which there is any beginning at all of a forest policy comprise less than about one-third of the forest region and a really serious, although still inadequate beginning can hardly be said to exist on more than one-fifth of the territory.

"The latest forestry legislation in Wisconsin is still largely of a tentative character, suggesting indefinite and impracticable or unnecessary experiments, with inadequate appropriations, toying with the situation, instead of instituting at once a well devised, professionally conducted management of the State's important forestry interests.

"The need of the hour is the realization by Legislatures and officials of the immediate seriousness of the situation, the establishment of well organized forestry bureaus in each State, conducted by professional foresters, and, above all, an efficient fire police. To this end the Association should have a carefully chosen committee, which should be ready to assist State authorities in formulating adequate legislation."

In his remarks Dr. Fernow referred to the collapse of the College of Forestry at Cornell University as an example of the absence of a serious and honest forest policy even in the State of New York.

#### WOOD PRICES.

The most persuasive argument for rational forest management has begun to be appreciated, namely, the advance of prices for wood materials. Within the last 5 years not only lumber prices but stumpage values have jumped at a marvelous rate. A few samples will illustrate this tendency. Last fall 36 square miles of timber limits in the Nipissing district in Canada were sold at \$200,000, which 5 years ago were valued at \$135,000. Another limit which had been sold at \$100,000, 3 times what it was valued at, 10 years before, in a few months having changed hands 3 times at advanced prices, brought \$210,000.

Last fall, too, the Ontario government doubled the dues on all timber cut to \$2 a thousand, and raised the ground rent on timber limits from \$2 to \$5 a square mile.

Pulp wood in Northern New York brings more than \$10 a cord, which only the year before could be had at \$7 to \$8.

A large area of Southern pine changed hands 3 times in a few months, the first purchaser hesitating at \$8 an acre, the last refusing more than \$20.

The change in prices of lumber does not necessarily parallel the increase in stumpage prices, because the elements of logging, transporting and manufacturing, enter and vary relationships; yet there is the same tendency of increase. Prices for the best lumber in the New York market today, with the exception of the fine, high grade furniture woods like walnut and cherry, have increased 50 to 100 per cent over prices of 15 years ago. That is an appreciation of 3 to 5 per cent. annually. The cubic foot of manufactured wood of best quality ranges now from 24 cents for hemlock to over \$1 for white pine; while most of the woods hover between 60 and 80 cents. Relatively the cheapest appears to be the Southern pine, costing about 55 cents for the choicest. The greatest rise was probably experienced by white pine, which from 1870 to 1900 rose 50 per cent. for best quality of lumber; but in the last 3 the price has risen from \$57.50 to \$90, or 56 per cent.

These figures are significant and they are a hopeful element in securing a more rational treatment of our forest resources. They accentuate the fact that these resources are waning; and better prices will make it more profitable to lumber with care, to protect forest property and to recuperate neglected wood lands.

#### WOOD PULP SUPPLIES.

Maine is said to be the chief source of the future supply of good spruce for paper making, and it is claimed that there are a little over 21 billion feet of spruce standing. If this were true, Maine could supply the present consumption of pulp wood in the United States for about 14 years; but if the consumption increases as in the past, namely, trebling every ten years, it will exhaust the Maine supply in half the time, for we are now using annually about 1,500,000 feet of pulp wood. Is it time to be alarmed? Somebody also guesses that the annual new growth on the spruce of Maine represents 637,000,000 feet, provided fires are kept out. This growth, even if it should accumulate for the 7 years during which the old growth is utilized, would not suffice for the 8th year. There are, of course, other regions furnishing a supply; nevertheless, it is wise, when the large estimates of supply are made, to put opposite them the figures of consumption. A significant fact in this connection is that in the last 3 years the importations of wood pulp have more than doubled.

## PURE AND IMPURE FOODS.

Edited by C. F. LANGWORTHY, PH.D.

Author of "On Citraconic, Itaconic and Mesaconic Acids," "Fish as Food," etc.

"*What a Man Eats He Is.*"

### THE USE OF AERATED WATERS.

According to an article in a recent number of a medical journal, "Whatever the stage of civilization man has reached, he has always made for his use some beverage more or less artificial in its mode of production, and having certain physiological effects, out of which arise more or less complex moral and physiological questions. If a man were made merely to "bask and batten in the woods," a draught of Adam's ale might be all that he would care for or find necessary to quench his thirst. The circumstances of our practical and social life, however, alter the case. In recent years there has been an enormous increase in the manufacture of aerated waters, made to imitate the various natural sparkling or so-called mineral waters, first made artificially by Priestly, who, when residing near a Leeds brewery, impregnated water with "fixed air" or carbonic acid. Thus one product of fermentation became the parent of that numerous class of beverages known as effervescing or non-alcoholic. Priestly may thus be said to have been the founder of the mineral water industry. He set forth his views in "Directions for Impregnating Water with Fixed Air in order to Communicate to it the Peculiar Spirit and Virtues of Pymont Water and other Mineral Waters of a Similar Nature," in a tract published in 1772, and sold for 1 shilling. He speaks of Pymont water containing a "fixed air," "an antiseptic principle administered in a great variety of agreeable vehicles." The original idea was that these waters should be most useful in preventing scurvy during long sea voyages.

Dr. Hamer, the assistant medical officer of the London county council, has published some remarkable statistics which show that nearly half the water estimated to be consumed for drinking purposes in the metropolis is aerated. In 10 years the increase has been prodigious. The number of bottles of aerated waters sold in London increased from 150,000,000 in 1892 to 500,000,000 in 1902. In 40 years the number of manufacturers of aerated waters in London has quadrupled, 401 in 1861, 1,756 in 1901; while the number of brewers has increased only from 3,006 to 3,406. The annual consumption of aerated waters in the United Kingdom is calculated to be 3,600,000,000 half pints. The average consumption of these fluids by the Londoner per head—man, woman and child—is about a quarter of a pint a day. Even that is only 90 pints

a year. Taking the consumption of beer as 31 gallons a head of the population per annum, it is obvious that there is plenty of leeway to make up ere the aerated waters have much effect on the beer trade. Probably, too, this great consumption of aerated water is not unassociated with the inroads of whiskey as a beverage, diluted, as it so frequently is, with some aerated water, natural or artificial.

"There is little ground, therefore, for hope that this enormous consumption of gas-charged waters is due to their displacing beer or other alcoholic beverages; nor is their consumption to be taken as an index of our increasing sobriety as a nation. The increase may be more safely ascribed partly to improvements in manufacture leading to reductions in price; to such beverages being thus brought within the reach of a larger class; and partly to a popular belief that, by using mineral waters, there is less chance of contracting zymotic diseases. On this point such information as exists is reassuring, for, as far as it goes, it bears out the more or less generally accepted idea. Thus Abba found that aerated waters inhibited the action of certain bacteria which are occasionally present in natural water. Cholera bacilli, it has been stated, are destroyed in half an hour to 3 hours.

"In places, therefore, where the purity of the ordinary water as regards the water-borne germs of zymotic disease is open to suspicion, there would appear to be some advantage in using aerated water. As regards other germs, however, the effect of which, if any, on the human system is but ill understood, ordinary tap-water would appear to be at least as free, if not much freer, from them than much of the aerated water now put on the market. The best manufacturers, no doubt, take great and successful pains to produce water of high initial purity, and adopt adequate precautions to avoid its after contamination during the process which it undergoes. This, however, is not the case with all, so in view of the importance which the trade has now attained, it is eminently desirable that it should be brought under control by the authorities on lines corresponding to those adopted in Italy several years ago."

### BREAD AND BREAD MAKING.

In the opinion of the author of one of the recent bulletins of the United States Department of Agriculture there is hardly

any food, except milk, which is so universally used, as bread; and not only is it now known almost everywhere, but since history began it has, in some form or other, made one of the staples of diet among all but the most savage peoples. In the earliest historical records it is spoken of, and the wild tribes which to-day inhabit South Africa know something of its use. Of course the bread made by the Kaffir to-day, or by the American Indian 300 years ago is different from our own. It would be interesting to trace the relationship between the bread-making processes of given peoples and their rank in the scale of civilization. The Kaffir simply grinds his grain between 2 stones, makes a paste of this meal and water, and bakes it in the ashes of his camp fire; Israel, in Egypt, ate leavened bread; the ancient Greeks cultivated the yeast plant; in Pompeii an oven was found containing 81 loaves of bread not unlike our own; the Swiss peasant still bakes his weekly loaves in the village oven; and so on, to the mammoth bakeries and innumerable fancy breads of our large towns. Such a classification would not be utterly absurd, for except among the lowest savages and in the extremest climates some kind of grain is recognized as a necessary food, and bread furnishes it in one of its most convenient forms; that is, a form in which it yields the greatest nourishment for the least labor and cost. No wonder, then, that the more intelligent a people the better bread they make.

The reason for this importance of bread is simple. Ever since the far off days when our forefathers first found the wild cereals, or began to cultivate them, men have known that food prepared from them would support life and strength better than any other single food except milk. The diet of the poor in India and China often consists almost entirely of wheat or millet cakes or rice, and although in our land the ease with which we can get other foods makes bread seem less important, there are still many districts in Europe where people eat little else. To a large part of mankind bread is still the staff of life, and if they pray for their daily bread, they mean it literally.

In regard to its ingredients, bread is one of the simplest of our cooked foods, but in regard to the change which the raw materials must undergo to produce a finished loaf, it is one of the most complicated. Flour, water, a pinch of salt, and a little yeast—the necessary things—can be counted on the fingers of one hand, yet to describe the processes of bread making with any degree of completeness would require many hundred pages. Without going into a detailed description of these processes, it will perhaps, be interesting to recall what the main steps in bread making are.

Beginning back in the flour mills, the grain is ground into powder, the coarser parts of which are sifted out as bran, while the finest constitute our flour. Once in the baker's hands, the flour is mixed with water and yeast, or something which will produce the same effect. When this paste or dough, containing yeast, is set in a warm place, the yeast begins to work, as we say, and the dough to rise; in other words, the yeast causes a change known as alcoholic fermentation to set in, one of the principal results of which is the production of carbon dioxide gas. If the dough was well mixed, this gas appears all through it, and, expanding, leavens or raises it. After the yeast has worked sufficiently the dough is shut up in a hot oven. Here the heat kills the yeast and prevents further alcoholic fermentation, causes the gas to expand and stretch open the little pockets which it forms between the particles of dough, and changes some of the water present into steam, thus raising the loaf still more. Further, the heat hardens and darkens the outer layers into what we call the crust. The sum of these changes in the oven we call baking. When they have been continued long enough our bread is done, ready to cool and eat.

#### LIMES IN THE WEST INDIES.

The lime industry of the West Indies, although small as compared with sugar and cacao, is yet of considerable importance at Dominica and Montserrat, the former supplying more than one-half the total exports of the islands. At Dominica, lime juice alone, raw and concentrated, to the value of \$156,759, and lime oil, the essential oil made from lime skins, to the value of \$14,366, were exported during the year 1901-2. These figures do not include the exports of green and pickled limes, in which a considerable trade is carried on with the United States and Canada. The increase in this trade may be seen from the fact that in 1898 the number of barrels, cases, etc., of green limes exported to the United States was 3,534 as compared with 7,412 in 1901. In 1900 428 barrels of pickled limes were exported to British North America, and 904 in 1901.

According to the Agricultural News, a journal published in Barbados, "the value of green limes in the United States varies from \$5 to \$10 a barrel, according to season and demand. From a barrel of limes, 7 to 8 gallons of juice are obtained. The juice is shipped either raw or in a concentrated form. The latter is boiled down to a density of 10 or 12 to 1; that is, 10 gallons of raw juice to 1 gallon of concentrated. It takes on an average 80 barrels of limes to give 54 gallons of concentrated juice. The value of raw lime juice in the

London market is about 10 pence (20 cents) a gallon and of concentrated juice about \$56 a pipe. The production of essential oil of limes forms an important branch of the industry. The oil is obtained from the rind of the ripe fruit and is exported either as hand pressed, or rind, oil or as distilled oil. In the preparation of the former, the oil is extracted by the *ecuelle* process before the fruit is passed through the mill. Distilled oil is recovered from the juice, after milling, by the ordinary process of distillation. The yield of rind, or hand pressed, oil, averages about 3 ounces a barrel of fresh limes, and it is worth in London at present prices about 97 cents a pound. Distilled oil is produced at the rate of 2½ gallons for each hogshead of concentrated juice and is worth in London about 43 cents a pound.

"At Montserrat, lime cultivation has formed, for many years, one of the chief agricultural industries. The yield of limes when the trees are in full bearing is at the rate of 160 barrels an acre. The yield of juice is calculated at 8 gallons for each barrel of limes. The cultivation of limes at Jamaica, Trinidad and Antigua is carried on to a limited extent, the value of lime juice exported from these islands during the year 1900 being \$36,479, \$1,927, and \$949, respectively. In the other islands the lime tree, although well known and found in nearly every garden, is grown to meet local requirements only."

#### CHRISTMAS PLUM PUDDING.

Without doubt plum porridge was the original form of plum pudding. It was made by boiling beef or mutton, and thickening the broth with brown bread. To the half cooked meat, fruit and spices were added and the dish was served as the first course of the Christmas dinner.

Plum pudding, proper, a recent writer states, does not appear in cookery books before 1675, and was not prominent as a Christmas dish before the Georgian days. At the early Saxon feasts, mince pies were served and have always been associated with Christmas festivities. The crust enclosing them was supposed to represent the manger in which the Holy Child was laid. The Puritans objected to these dishes because they savored of superstition.

An English authority makes the following calculation as to the quantity of plum pudding consumed in Great Britain annually. The country has a population not far from 40,000,000, and probably at least 4,000,000 puddings are prepared for Christmas day. A vast number of these puddings are sent to Australia, India, and other colonies, and many families prepare a number of puddings at that time to be used later.

These puddings would average rather

more than 4 pounds each in weight, making a total of nearly 8,000 tons. This quantity would require 2,600 tons of raisins, nearly 1,000 tons of currants, and an equal quantity of mixed peel, as well as about 30,000,000 eggs, to hold the fruit, suet and bread crumbs together.

At Aughton-in-Halton, near Lancaster, a flourishing firm of weavers, a little more than a century ago, erected an immense oblong boiler for the purposes of their trade, and when first set up it was inaugurated by the boiling in it of a huge plum pudding of about a ton in weight.

What was probably the largest plum pudding weighed a ton and a half. It was made at Christmas time, in 1858, to celebrate the opening of the railway to Paignton. It contained 573 pounds of flour, 191 pounds of bread, 382 pounds of suet, 191 pounds of currants, 382 pounds of raisins, 320 lemons, 144 nutmegs, 95 pounds of sugar, and 360 quarts of milk, besides a large number of eggs. It was cooked in sections and afterwards built together.

Plum pudding is commonly considered indigestible, but most persons would probably be unwilling to omit it from the Christmas *menu* on that account.

#### ARSENIC IN FOOD.

The large quantity of arsenic found a year or so ago in English beer, which caused such disastrous results in Manchester, England, has led to investigations to determine whether arsenic is present, accidentally or otherwise, not only in beer, but in many other articles. In the case of the English beer, the presence of arsenic was traced to commercial glucose used in beer making, much of the sulphuric acid which entered into the manufacture of the glucose having been made from Swedish pyrites having an abnormally high arsenic content.

Prof. Albert E. Leach, of the Massachusetts State Board of Health, is authority for the following statement: "It is well known that arsenic is commonly present in commercial sulphuric acid, and would also naturally occur in any food product into the manufacture of which sulphuric acid had entered. For this reason, various food products have been examined in this laboratory for arsenic, and a number of samples of commercial glucose have been found to contain it, but to a slight extent only. Arsenic in small traces has also been found and would naturally be expected in food compounds wherein commercial glucose was an ingredient, such, for example, as honey, molasses and maple syrup of the compound or adulterated variety, as well as confectionery."

Traces of arsenic were also found in some other food materials, but not enough to be an element of danger.

## PUBLISHER'S NOTES.

H. A. Morine, G. P. A., Reid's Newfoundland Railway, has devised a plan for taking care of sportsmen who visit that island, which is certainly unique, and which will be appreciated by all hunters who have occasion to go there. Mr. Morine tells me he will gladly employ guides and buy food for sportsmen, charging them only the actual cost of the supplies and guides' services. He says he has adopted this plan in order to prevent extortion on the part of the guides, which is practiced to such a disagreeable extent in some other hunting and fishing countries. Mr. Morine says he knows personally every good guide on the island, and is in constant communication with all of them. He has notified them that he is making this proposition to American sportsmen; that each guide will be given employment in his turn; and that whenever any one of these men fails to do his full duty he will be promptly dropped from the list.

If you contemplate a trip to Newfoundland next year, for the purpose of fishing or hunting, it will be well to write to Mr. Morine now, giving him the exact date when you will reach the island, and asking him to provide the guide and the necessary food supplies.

When communicating with him kindly mention RECREATION.

It may interest the readers of RECREATION to know how a big lens factory eats up materials. The Bausch & Lomb Optical Company, of Rochester, has recently issued a book giving some interesting figures in this line. Here are a few of the items, showing consumption in one year:

- 600,000 pounds of optical glass.
- 30,000 pounds of crown and flint glass.
- 7,750,000 screws.
- 150,000 pounds of emery powder.
- 450,000 paper boxes for packing lens, shutters and other articles.
- 10,200,000 pounds of coal.
- 30,000 pounds of brass tubing.
- 110,000 pounds of brass rod and sheet brass.
- 1,200,000 cubic feet of gas.
- 210,000 pounds of iron castings.
- 30,000 pounds of steel.
- 50,000 pounds of brass castings.

I have not room here to give all the information I should like to give about this business. An idea of the vast output of that factory may be obtained from the statement that these people turn out 20,250,000 spectacle lenses in a year, over 10,000,000 simple

lenses for photographic purposes, and over 550,000 photographic shutters.

It is scarcely necessary to add that a house which has created such a demand for its goods is a safe one to deal with.

---

The Syracuse Arms Company has moved, and is now comfortably installed in its new plant at 1415, 17, 19 and 21 North Salina street, Syracuse, N. Y.

The new building is equipped with the best and most modern machinery and tools known to the gun making industry. The works now occupy about 25,000 square feet of floor space and employ 90 to 125 men, as occasion requires. Electric power is used exclusively, and the machines are so grouped and controlled that with the 7 motors employed each group of machines may be run singly or all together, reducing the cost of power to a minimum. Skilled mechanics of the highest order are in charge of the various branches of the factory. The general offices are large, roomy, well lighted and handsomely furnished.

Eight years ago the Syracuse Arms Company had one floor in a small building on Walton street, and employed only 8 or 10 men. The stock room was full of guns and it was often difficult to market them. To-day, with all its increased force and facilities, the company is away behind on its orders and has practically no stock on hand. The company has a full page ad in the first issue of RECREATION, and it has been in every issue of the magazine from that day to this. Further comment is unnecessary.

---

The Davenport Fire Arms Co., of Norwich, Conn., has issued a new catalogue that is a surprise even to those who have watched the development of that factory for years past. When I first called on this company, in 1894, it had a little shop on the 4th floor of an old brick building and employed perhaps a dozen men.

To-day it occupies an entire large modern 5 story brick building and employs about 100 men.

In the old days the company made one style of single barrel shot gun, which retailed at about \$5 or \$6. To-day it makes 11 different models of single guns, listing at \$8 to \$20 each, and a neat, tasteful, serviceable rifle, besides. The new catalogue illustrates and describes all these weapons and gives a great deal of useful and valuable information for shooters. Get a copy of it and mention to the publishers that you saw it announced in RECREATION.



The Ithaca Gun Works has issued a new catalogue showing some artistic and beautiful engravings of their high grade guns. Any sportsman getting a copy of this book will be sure to linger over these pictures and to wish he could swing one of the guns over his shoulder and go into the field. The Ithaca people are making guns listing at \$32 up to \$300. The high priced guns do not shoot any better than the cheap ones, but there is an immense satisfaction in owning and caring for a finely made and finely finished article of any kind.

Send for a copy of this catalogue and see if you are not tempted, when it comes, to cut out some of the pictures and frame them. In writing please do not forget to tell where you read of the book.

Ideal Mfg. Co., New Haven, Conn.

Dear Sirs: The new Ideal loading press has proved satisfactory in every particular. We have reloaded 25,000 rounds of Krag 30 caliber for team work at Creedmoor, L. I., and Sea Girt, N. J., and the ammunition we turned out was uniform in every way; shell properly resized, bullets seated and shell crimped in a uniform manner to insure accuracy. The results of this year plainly show that due to good reloaded ammunition the 71st regimental team won both the State and brigade prizes at Creedmoor.

Respectfully,  
Capt. G. W. Corwin,

I. S. R. P. 71st Reg't N. G., N. Y.

Captain Banning, yesterday, received the handsomest 16 gauge single trigger shot gun ever made in this country. It is inlaid with gold and engraved by one of the best artists in the United States. A brace of pointers at work and a brace of setters make the gold decorations on the frame; a duck in flight, also in gold, with quail at rest, and oak leaves with acorns in gold, complete the gold design. The engraving on the barrels is in keeping with the work on the stock. This beautiful weapon was made to order by D. M. Lefever, Sons & Co., Syracuse, N. Y.—Los Angeles, Cal., Herald.

Schoverling, Daly & Gales have issued a catalogue of shot guns, rifles and pistols, which is a beauty and a novelty. It contains some beautiful half tone cuts of Daly and Stake guns, Mauser rifles and Luger pistols, and full descriptions of them. The margins of the book are covered with dainty hunting scenes that make one long to get behind a gun and into the woods. Every man who likes to do such things should write for a copy of this book, and if, when asking for it, you will say you saw it mentioned in RECREATION, you will thereby help to push a good thing along.

It may interest you to know that my boat business this year has increased enormously, being up to the first of October nearly double my entire sales of 1902, and 4 times as great as the sales of 1901, with 4 months of my business year yet to run. The new line of boats I placed on the market this year has taken remarkably well, and the outlook is that I shall have an enormous business in the next year. I have been compelled to start another factory in which to build my boats, and believe there is a great future in this boat business.

W. H. Mullins, Salem, Ohio.

Patent No. 740,293 has been issued to G. E. Loebke, of New York city, on a decoy duck, with machinery which, at the will of the user, causes the duck to flutter up and down as if attempting to arise from the water.

Patent No. 740,327 has been issued to Charles E. Stalloop, Sac City, Ia., for improved mountings for rifle telescopes.

Persons interested can secure copies of these patents by addressing the Commissioner of Patents, Washington, D. C.

New York.

West End Furniture Co.,  
Williamsport, Pa.

Dear Sirs:

I bought one of your sportsmen's cabinets 2 or 3 years ago. Please ship me another cabinet, of golden oak finish, to the address below. This second purchase is certainly sufficient to indicate my appreciation of the convenience and comfort offered by your No. 20 cabinet.

E. H. Coe.

A patent, No. 740,486, has been issued to H. A. Tellerson, Oakland, Cal., for a gun cleaning rod, that is a decided novelty. The rod is hollow, with a string passing through it, to one end of which is attached a strap of cleaning fabric and a fold of flexible material that are intended to adapt themselves to the grooves and lands of the rifle. Judging from the cut and description of the rod, it is one of the best implements yet devised for thoroughly cleaning a rifle.

Northern Rubber Co.,  
St. Paul, Minn.

Over one year ago I bought from you one No. 20 Banner mackintosh and I have given it the severest test. I find it absolutely waterproof. On one occasion I was in the hardest rain I ever saw for 2½ hours constantly and never a drop came through. In all respects the Banner mackintosh is an A No. 1 coat.

Geo. Zook, Downington, Pa.

## EDITOR'S CORNER.

### A HIGH COURT ENDORSES RECREATION.

Harry Winters, of Helena, Mont., whom the local papers, of course, mention as a "prominent business man," was arrested some time ago by State Game Warden W. F. Scott, charged with dynamiting fish. Winters pleaded not guilty and prepared to fight, but after taking more time to think it over, he went into court with his attorney, withdrew that plea and entered one of guilty. His attorney made a brief argument in Winters' behalf, asking the court to be lenient with the prisoner. Judge Henry C. Smith, who was presiding in the District Court, told Winters what he thought of him in words and figures as follows:

What your counsel has stated is true. You are a man who has been in business in this community, an intelligent man, a man who, I understand, has been fairly successful in your pursuits. Of course in dynamiting fish you must have acted advisedly. I am informed by the game warden that you were well posted as to the penalties for dynamiting fish and thoroughly understood the difference in penalty between seining them and dynamiting. I regard dynamiting fish as a serious offense; it is an unnatural offense.

A man who will dynamite fish must be absolutely devoid of sportsmanlike qualities. People who dynamite fish have been characterized in journals relating to outdoor sports as hogs; and that is an appropriate designation. One man is limited by law to catching fish with a hook and line; another man comes along, clandestinely drops a stick of dynamite into a hole and kills, not only the large fishes that are good to eat, but every fish that is in the hole, and the fish food besides. Not only that, but the fish are mutilated and some of them rendered unfit for food.

In passing sentence on you, Mr. Winters, I desire to act in such a way that others may thoroughly understand the situation. I do not care to impose a penalty that may be thought too severe. At the same time I believe the Legislature must have thoroughly recognized the heinousness of this offense, in placing the minimum penalty at \$200.

I do not wish to make a martyr of you, yet I wish to punish you, and to deter

others from doing what you have done. My private information is that there is a good deal of dynamiting in the streams of this State. I shall impose a fine on you, but I serve notice that the next man who comes here charged with the offense you are charged with, if found guilty and I am here, I shall certainly send to the penitentiary.

I have known you a number of years, and it is not an agreeable duty to pass sentence on you, but I am bound to punish you for what you have done. I am surprised that a man of your intelligence and standing in the community should do such a thing. You knew it was against the law; it is the worst possible infringement of the game law, in my judgement. There is no excuse for it, whatever.

The sentence of the court is that you pay a fine of \$400, and that you stand committed to the custody of the sheriff until that fine is paid.

I call special attention to Judge Smith's statement that, "People who dynamite fish have been characterized in journals relating to outdoor sports as hogs; and that is an appropriate designation."

This remark proves conclusively that Judge Smith is a reader of RECREATION, for this is the only journal devoted to outdoor sports that calls any man, no matter what he may do, a fish hog or a game hog. Nearly all the other sportsmen's journals have criticised RECREATION for calling people "names," because they slaughter game or fish. I further emphasize Judge Smith's expression, in which he pronounces the term "fish hog" an appropriate designation for a man who dynamites fish.

I have been condemned by thousands of good people for the use of the terms "fish hog" and "game hog;" but here is a judge of a high court who approves my course, and who freely expresses his contempt for a man who destroys fish in this way, by inflicting a fine of \$400 on him.

This should settle the question as to the justice of my method of dealing

with men who wantonly destroy fish and game.

It is only fair to conclude that if Judge Smith had not been reading RECREATION, he would not have known just how contemptible a creature a fish dynamiter is, and would not have placed so heavy a fine on Winters.

Judge Smith should have a monument and I am not sure that I shall wait until he dies to begin the collection of funds to build him one.

#### SOME PUMP GUN WORK.

Several of my contributors when discussing the pump gun have insisted that it is not a game hog's weapon; that it is the man behind the gun who is the hog, and that the gun has nothing to do with the case. I grant that claim, for the sake of argument; but since the game hog is abroad in the land, he should be prohibited from using anything more destructive than a double barreled gun. Here is a statement made by a game dealer who employs several experts to shoot for him all through the year, and it is scarcely necessary to say these men are all armed with pump guns. The dealer starts his men after the ducks when they cross the Canadian border, follows them down through the States and into Old Mexico, where the men shoot all winter and ship the ducks back into the States. The dealer says:

"Sitting one morning in a blind with a crack man, I said, 'Clay, let me see what you can do in the way of fast shooting.' At once Clay sounded the call and 4 mallards that were flying over stopped and began to flutter down between the tree tops. Instantly Clay's gun gave out 4 reports in quick succession. Before the first duck struck the water the victim of his last shot was whirling in the air. I could scarcely have believed this feat possible had I not seen it with my own eyes."

With a double barreled gun Clay could not possibly have killed more than 2 birds out of the 4. This is not an isolated case. These market hunters often walk the ducks up out of marshes or small pools, and frequently a dozen or more mallards get up close together. It is easy for the man behind the pump gun to get 5 or 6 birds at one rise. In other cases the shooter takes his place in the bow of a boat and has a man in the stern push him through the reeds, rushes or wild rice. The birds are jumped in bunches and cut down with the pump gun before they can get out of reach. In pass shooting a man may

get 6 birds out of a flock that flies low over his stand; or, if shooting over decoys and a bunch comes in, he can do equally destructive work on them with this modern machine gun. Therefore, I say the pump gun is a disgrace to civilization and its use should be prohibited by law, just as the swivel gun now is.

The automatic gun is simply another long step toward the total destruction of American game birds and its use should also be interdicted. It will take a long time to secure the enactment of laws in the various States prohibiting the use of these weapons, but public sentiment can at once relegate them to the ranks of market shooters and game hogs. Let it be understood from to-day that no decent man in the United States will ever use an automatic gun, and that no gentleman will associate with the fellows who do use them.

#### NEWSPAPER NATURAL HISTORY.

Here is another sample of newspaper talk about the habits of wild birds and animals. One Forrest Crissey writes a long article for the Saturday Evening Post about duck shooters. He tells of one market hunter who bought some canvas decoys and put them out on an Arkansas river. He camped on the bank of the stream. The next morning several of his decoys were missing, but were finally found hanging on bushes in the neighborhood. The hunter imagined that some native who was jealous of the shooting rights had peppered the canvas decoys with shot and then hung them up to dry; so the market shooter watched for the aggressor. Crissey tells the sequel in these words:

"About midnight the native came, sure enough. Bishop, the hunter, was just getting into a doze when the stillness of the woods was shattered by an unearthly screech. There was a commotion in the upper air, and 2 huge Arkansas owls swooped down on the decoys, thinking them to be live mallards, their natural prey. Of course, Bishop shot the vandals, but he made the mistake of telling his experience, with the result that he was called Owl Bishop from that time forth, and has not yet heard the last of his adventure. He went back to the use of the good, old fashioned wood decoys and has used no others since."

Of course, the owl would utter an unearthly screech before descending on a bunch of mallards. That is, he would in the imagination of the average newspaper writer.

#### GOOD WORK OF THE L. A. S.

The Georgia Legislature, at its last session, passed an up-to-date game, fish and bird law, and Governor Terrell at first declined to approve it because it provided

that the informant in cases of violation of the law should receive one-half the fines. This moiety system is objectionable to many good men, but on the other hand it has its advantages. As a rule, no man likes to complain of a neighbor. If he does so, he takes the chances of incurring the ill will of his neighbor and perhaps of suffering injury as a result. It is only fair and right that he should be compensated to some extent. Furthermore, there are many good friends of game protection who are poor, hard working men, and who can not afford to lose the time necessary to prosecuting an offender, unless they can be compensated for it. Hence the moiety system seems an absolute necessity in such cases. As soon as I learned of Governor Terrell's attitude in the matter, I wrote a personal letter to each member of the League in Georgia, urging him to take up the matter with the Governor and importune him to approve the bill. Our Georgia members acted promptly on this suggestion, and as a result the Governor approved the bill. Thus Georgia has a good game law.

There are men everywhere who say the L. A. S. is a pet scheme of mine; that I am doing this work for personal gain and all such rot. I am willing, however, to endure all sorts of abuse as long as we can occasionally score a victory like this.

#### THE ALASKA SALMON FISHERIES.

President Jordan, of Stanford University, and Dr. Barton W. Evermann, in charge of the division of Scientific Inquiry of the U. S. Bureau of Fisheries, have returned from Alaska, where they spent 3 months studying the salmon fisheries and the conditions under which they are carried on. They were accompanied by a number of assistants and had the steamer *Albatross* at their disposal. They visited all the salmon canneries and salteries except those in Cook inlet and Prince William sound, which had finished their pack and closed down before the *Albatross* could reach them.

It is understood that the present regulations governing the salmon fisheries are not satisfactory, and that Doctors Jordan and Evermann will recommend a number of important modifications.

The salmon are unquestionably decreasing in abundance and the fisheries can be saved from depletion only by artificial propagation on a large scale. The commission will therefore recommend the establishment of a number of government salmon hatcheries. They will urge the necessity for careful study of the many salmon streams and the habits of the 5 species of salmon, also the rigid inspection of the methods of the fisheries, canneries, and salteries.

#### AND IT CAME TO PASS.

In the February, 1901, number of RECREATION I said:

The proposition to restock the Adirondacks with moose is extremely visionary. It would be easy enough to buy 10 or 20 or even 50 moose and turn them out there, but they would no doubt speedily share the fate of the one that is supposed to have escaped a few months ago from Dr. Webb's preserve. There are a lot of vandals in the Adirondack region who pose as guides, and any one of whom would kill a tame cow if he thought he could get away with the meat without being caught. These men would soon clean up any number of moose the State might favor them with.

The State did buy a number of moose and liberate them in the Adirondacks. Several of these animals have been found dead, as well as some of the elk which Mr. Whitney turned out there. And lest you forget, I say it again: Why cast pearls before swine?

A colony of gray squirrels has been living in New York Zoological Park until last fall, when most of them moved across the Bronx river, outside the lines of the park. There they were set upon by a lot of savage boys and men, armed with shot guns and rifles. The brutes pursued the little pets until almost the last one was killed. Some of the men are known to have killed as many as 10 squirrels, and though the police pretended to be alert no arrests were made. A man or a boy who would kill a gray squirrel under such conditions would steal his grandmother's spectacles and sell them.

Columbus Buell, of Batavia, N. Y., went fishing in April last and caught about 30 trout. Four of those he took home were under the legal size. Game Warden F. E. Taggart lit on Buell as he wended his way homeward, inspected his basket, found the fingerlings, took Buell to court and the judge assessed him \$55, a big price to pay for 4 little trout.

I am informed that Jas. Boulton and George Cowfer, of Hautzdale, Pa., on Sunday, April 19, were caught fishing for trout in Trout run, by members of the Osceola Gun Club. When arrested and taken before Squire Sandford, of Philipsburg, they pleaded guilty and were fined \$30.60 each. Served them right.

Dr. William C. Kendall, of the United States Bureau of Fisheries, spent last summer and fall studying the rivers and lakes of Maine. He has in preparation a report on the fishes of Maine which the Bureau hopes to publish soon.

Purity—above everything—distinguishes Schlitz beer from the common.

There's a difference, of course, in the barley, the hops, the yeast. We use the costliest materials. But the goodness of Schlitz is mainly due to its healthfulness.

The artesian water used—the absolute cleanliness—the filtering of the beer, and of even the air that touches it—the extreme aging—the sterilizing of every bottle after it is sealed; those are the facts that make Schlitz what it is.

Those are the reasons why the demand for Schlitz exceeds a million barrels annually.

Yet no standard beer—no beer that is good for you—costs less.

*Ask for the Brewery Bottling.*



## ON THE RACKET RIVER.

DR. E. P. STUART.

September 20, 1897, Mr. and Mrs. David H. Decker, my wife and I, started for a hunting trip on the Racket river, Cary Falls being our objective point. We reached there at 2 p. m. the second day, tired and hungry. After a good meal and a night's rest we were much refreshed, and spent the greater part of the next day arranging the cottage where we were to stay. In the afternoon I started out to fish, taking a new spinner I had never tried, and a strip of fat salt pork. Getting into the boat, I let out my line and pulled across to the other shore. I had only turned around and straightened out my line when something struck. I played him some time before I got him alongside the boat, and lifted him in, as I had no landing net. He proved to be a 2½ pound pickerel. Before reaching the shore I took another, almost his exact counterpart. They were much darker than Lake Keuka pickerel, more solid and sweeter. As they were enough for supper, I caught no more that evening.

The Hollywood stillwaters at this point are better known to lumbermen, hunters and guides as the upper and lower bogs of the Racquet river. These waters contain bass, muskalonge, large pickerel, perch, bullheads and pike; and in fishing from the rocks over the falls some large trout have been taken. In the many brooks flowing into the river there are large numbers of trout.

The falls are beautiful. Two large rock islands, standing high out of the water, divide the river into 2 streams. At low water one can walk across on the rocks from shore to shore, with the water boiling and splashing between.

The scenery along the Racket is grand. The upper Hollywood stillwater is 5 miles in length, and ¼ to ½ mile in width. It is dotted with numerous islands and huge rocks sticking out of the water, but not to interfere with pleasant boating. The stillwater below the falls is 3 miles in length and about the width of the other. Both seem more like lakes than like a river.

The next morning after breakfast we crossed the river and took to the woods. They are magnificent; giant birch, beech, cherry and maple trees on the higher grounds, spruce, balsam, ash, and pine on the lower, all unbroken forest except occasionally a lumberman's shanty. We went about a mile and raised 2 deer but did not get a shot. We found their beds still warm, and heard the deer run.

The first week I did not hunt much, being unable to tramp far. I had some sport, for all that. I went into a cedar swamp not far away, and killed all the grouse we could use. I might have killed more, as they were plentiful. I had fairly to kick them up before they would fly.

I also caught enough perch, pickerel and bullheads to supply both families with all we could eat. In fact, we had no meat at

any time except what we killed, and 3 pounds of salt pork.

One night Dave came in and said he had killed a large buck, and that after he had shot him the buck had jumped into a cranberry swamp. He said he could hear the creature floundering in the brush a distance ahead and heard some hard breathing; then all was still. It was so dark he could not see, so he decided to wait until morning to bring the buck in.

Accordingly, in the morning we took the boat, paddled up the river about 2 miles, landed, and, guided by Dave, soon reached the place. There were the fresh tracks of a large buck and the place where he jumped into the brush, but we found no blood. We followed the trail some distance, then spread out and thoroughly canvassed that cranberry swamp, but we could not find a dead buck. We finally gave it up.

Dave redeemed himself by killing a large buck a few days later.

I hunted faithfully nearly all the week, but with poor success. I had 2 to 4 deer up every day but they were too wary for me, and I got only one shot. At last I succeeded in getting a large, fat, dry doe. One secret of my failure was that I never had been accustomed to still hunting. I had always hunted with hounds, but I am glad hounding is abolished.

We did little more hunting except for grouse, and killed only enough of them to eat, not being game hogs. The ladies enjoyed the trip greatly, boating, fishing and wandering in the woods.

The plunge of the muskrat was almost incessant. Otters were quite numerous. We saw several; also a great many minks. The river was in almost constant commotion as far as we could pull. Occasionally we could hear the squall of a wildcat on the shore, or the whistle of the deer coming down to the water to feed. Deer are numerous in the woods and along the river.

Although we saw no bear we saw plenty of signs. One day we landed at a place where a little stream entered into a larger bog filled with water. There we saw the track of an unusually large bear. White rabbits are numerous in the woods and swamps. Altogether Carey Falls is a delightful place for hunters and those who need rest.

The worst luck I can wish RECREATION is that a year from now its circulation may be 500,000 copies. You are giving the sportsmen of the country the best magazine that has ever been published, and you deserve success

W. H. Mullins, Salem, O.

There's a young woman who makes little things count.

How does she do it?

Teaches arithmetic in a primary school.  
—The Pathfinder.

RECREATION is the best magazine published.

C. R. Wagner, Oak Park, Ill.

# THE EQUITABLE

HENRY B HYDE  
FOUNDER.

J.W.ALEXANDER  
PRESIDENT

J.H.HYDE  
VICE PRESIDENT



## Past, Present and Future Christmases

were all shown to Ebenezer Scrooge in Dickens' "Christmas Carol". Suppose you could be shown your future Christmases, or those of your family?

Don't you think it might possibly cause you to at once take steps to protect your loved ones and to provide for your own old age?

An adequate Endowment Policy in the Equitable will accomplish both of these results.

*Vacancies for men of character to act as representatives*  
Apply to GAGE E. TARBELL, 2nd Vice President

For full information fill out this coupon, or write

The Equitable Life Assurance Society of the United States  
120 Broadway, New York Dept. No. 16

Please send me information regarding an Endowment for

\$.....if issued at.....years of age

Name.....

Address.....



## AMATEUR PHOTOGRAPHY.

"For sport the lens is better than the gun."

*I wish to make this department of the utmost use to amateurs. I shall, therefore, be glad to answer any questions and to print any items sent me by practical amateurs relating to their experience in photography.*

## INSTANTANEOUS TONING.

The following formula gives absolute permanency and a beautiful rich and uniform tone on Solio within 30 seconds after leaving the printing frame. I have exposed prints to direct sunlight for 3 months, with one-half covered by black paper, and can not now see the line between the covered and the uncovered parts.

Mix a 10 per cent. solution of sulpho-cyanide of ammonium, mark A; dissolve 15 grains chloride of gold in  $7\frac{1}{2}$  ounces water, mark B; mix a 10 per cent. solution of phosphate of soda, mark C; mix a saturated solution of borax, mark D.

To use, take in the following order:

A .....	1 dram
Water .....	8 drams
B .....	4 drams
C .....	1 dram
D .....	2 drams

For the professional this formula may be found expensive, as it uses more gold than the old baths; but that need not be considered even by the most economical amateur, for it is such a small percentage of his expenses. It has cost me considerably less than the old baths did, because, even with the combined bath, it was impossible to avoid waste, while with this one need not waste one grain of gold in 10 years. Pour from the 4 bottles of perfectly stable solutions each time sufficient to tone 4, 10, or 50 prints, or as many as may be ready, and use it all.

No preliminary washing is needed. Print a shade deeper than the mounted print is to be, and put prints direct from the frames into the mixed bath, or they may be kept a week or 2 in a dark place. They will turn red, but in less than 30 seconds they will change to a beautiful dark purple, almost black in the shadows, and will not change again, even if left an hour or more in the bath. As soon as they reach a uniform color they may be thrown at once into a fixing bath, one ounce of hypo to 10 ounces of water; or they may be put in clear water until all are toned and then fixed. Fix 20 minutes, being careful not to let them mat together too closely for the hypo to do its work, but I have not found it necessary to keep them moving. Lastly, wash an hour in running water or in 10 changes in about the same time. They may be hung up to dry or squeezed on ferro-

type or glass or ground glass. If the parts are drams, as above, the aggregate 2 ounces will tone 10 4 x 5 prints. The last few will take a little longer to reach the full tone, and if more are put in, or if the chemicals are not pure, they will have a reddish tone, showing the bath to be weak or exhausted. Make up a fresh lot. If you have only 4 4 x 5 or 2 5 x 7 prints to tone, pour out only one cubic centimeter or 15 minims of sulpho-cyanide, 120 minims water, 60 minims gold, etc., and the 4 drams will be just enough. Instead of immersing the prints, lay them, one at a time, on a sheet of glass, such as an old negative, and swab them over lengthways and crossways with a wad of cotton or a brush, holding the corner of the plate over the graduate in order to use the drainings until the uniform tone is reached. It is a peculiarity of this bath that, no matter how streaky the prints look at first, if they are brushed over they will become entirely uniform in tone. Give the print all the gold it can take, and it will keep it, apparently for all time. It is easy to make a table from the foregoing 2 examples which will enable one to pour off each time just enough to tone the number ready. The 4 original solutions will keep indefinitely, but it is better to keep them in dark bottles or in a box, away from the light, and well corked. I have kept them months without deterioration, but after mixing the 4 the bath must be used within an hour. If called away, throw it out and mix afresh. It is worse than useless to keep it. The easiest way to make a 10 per cent solution is to measure 10 ounces of water, pour into a clean bottle and paste on a label so that the top edge just marks the height of the 10 ounces. Then pour out half the water, put in the ounce of dry chemical, and after dissolving, fill up to the 10-ounce mark again with water. Next time it will not be necessary to measure at all. In the borax bottle, one can always keep a saturated solution by adding water and borax, it being only necessary to see that some undissolved borax is always present at the bottom. Use pure borax, not that sold for laundry purposes. Ask for plain phosphate of soda, not the tribasic.—Percy M. Reese, in *The Camera*.

## ORTOL AND OTHER THINGS.

In order to answer Earl Dunn's inquiry in March RECREATION as to best 4 x 5 camera for a beginner to buy, one should know what the beginner is willing to pay for the instrument and what use he expects to make of it. I would say, however, that for a moderate priced outfit, a camera with a long bellows, reversible back, and double lens of which the back combination can be used alone, should be selected. The cycle



or pony style is more compact and portable. With a camera of this sort, and a supplementary Ideal wide angle, an Ideal portrait lens and Ideal ray filter, one can do almost any kind of work the average amateur will care to undertake.

I have found a good developer in ortol; especially good for an amateur, because it can be purchased in tubes all ready to be dissolved, and with soda and ortol compounds separate. It is equally good for plates or papers, giving negatives of fine printing quality, and of any desired detail or density, according to strength of solution and length of time it is used. It acts slowly on gaslight papers, giving plenty of time to stop development at any desired point. Dissolve contents of ortol tube in 20 ounces of water and of soda tube in 20 ounces of water. For plates, one part soda solution, one part ortol solution and one part water is a good normal developer. To tell when a plate is sufficiently developed, count the number of seconds from time developer is poured on to time high lights begin to appear, and leave plate in developer 10 times as long as it takes image to begin to appear. That is, if high lights begin to show in 30 seconds, leave in developer 5 minutes altogether. This will give good, strong negatives; but if they are too dense to suit your taste, leave in 8 or 9 times number of seconds it takes high lights to appear, or whatever length of time may suit your taste. For papers use one part ortol solution, one part soda solution and 4 parts water. Add a drop or 2 of 10 per cent solution bromide potassium to each 4 ounces developer.

I have had none of the trouble with Cyko paper blistering mentioned by some of your correspondents, and think they can not follow directions closely, or perhaps do not use an acid fixing bath. It is possible they have some of the solutions too warm. If fixed sufficiently and thoroughly washed, it is probably as nearly permanent as any paper made.

How many amateurs test their dark room lamp? It should be done by all means. Put a rapid plate in your holder. Pull the slide half way, and hold in front of your lamp, at about the distance you hold your plate to examine it while developing, 5 minutes. Then develop the plate in regular developer. I think the result will convince you that you should keep your plate out of the light as much as possible while developing. At least I had that result, and my lamp is fitted with both orange and deep ruby glasses and is none too bright to see by. Why would it not be a good plan to develop plates by time method alone, as is done with the Eastman developing machine, using a developer of a certain strength and temperature and plates of one brand, and

after trial finding what length of time it takes to develop to proper density? Thus there would be no danger of fogging by exposure to red light and negatives would consequently be clearer and crisper. After 2 years' experience and developing hundreds of plates, I find it yet difficult to tell by examining the negative just when to take it out of the developer. The timing method seems to give as good results as the old method with films. Why not with plates?

Jack Johnson, Hammond, Ind.

#### IMPROVEMENT OF NEGATIVES.

Although there are commonplace processes well understood by most photographers, some amateurs who are taking their first steps in photography will undoubtedly find a brief description of simple methods valuable. Not being satisfied with the results of the bichloride of mercury method of intensification, and wishing a more convenient method, I tried uranium and found it satisfactory. I make 2 stock solutions and keep them in dark bottles. The solutions are as follows:

A.—Water, 4 ounces.

Uranium nitrate, 3 ounces.

Nitric acid, c. p., 1 dram.

B.—Water, 4 ounces.

Ferricyanide potash, 2 drams.

For use take one dram of A, one dram of B, and 4 ounces of water. Soak the negative, if dry, half an hour or more in water; if just developed and fixed, simply wash it thoroughly before intensifying it. Put the negative in a tray, with the solution, and keep in constant motion, examining it frequently to see whether it is dark enough. When the desired density has been obtained wash the negative half an hour in clear water. If the intensification has gone too far it can be reduced to any degree by soaking the negative in water to which has been added a few drops of ammonia.

For the reduction of negatives I use 2 methods. First, the old hyposulphite of soda and ferricyanide of potassium solution for over exposed or over developed negatives; and, second, ammonium persulphate when it is essential to keep the detail in the shadows.

For the first method, according to the books, make 2 stock solutions:

A.—Water, 1 pint.

Hypo, 1 ounce.

B.—Water, 4 ounces.

Ferricyanide potassium, 2 ounces.

For use take of A 8 ounces and of B one ounce. Put the well soaked negative in the

solution and keep in motion. When reduction has gone far enough, remove the negative and wash it thoroughly. I find a much easier way of using this method is to make as needed a solution of ferricyanide of potassium, using about half a dram, bulk measure, of the crystals to 8 ounces of water. If the negative is to dry soak it in the hypo fixing bath half an hour before putting it into the ferricyanide solution. If it has been just developed and fixed place it in the ferricyanide solution directly from the hypo bath. The film will carry enough hypo to enable the ferricyanide to accomplish reduction. Rock the tray constantly, stopping frequently to examine the plate, and take it out of the bath when the reduction is sufficient. Then wash the negative about one hour.

To reduce with ammonium persulphate, place the well soaked and thoroughly washed negative in a solution made by dissolving one dram, bulk measure, of the persulphate in 4 ounces of water. This solution does not keep well, so it must be freshly made each time. Keep the tray in motion, and when reduction has taken place transfer the negative to a solution of 2 drams of sodium sulphite and 4 ounces of water, which in a few minutes will stop the action of the persulphate. Follow this by a thorough washing.

R. L. Wadhams, M. D., Wilkes-Barre, Pa.

HOW TO PRINT ON CROCKERY, ETC.

The easiest and cheapest method is to print direct from the negative. Only film negatives can be used for part of this work. To print proceed as follows: Beat up sufficient quantity of the white of eggs to cover the portion of the surface desired to print on, and then mix the following solutions:

No. 1.

Water ..... 4 ounces  
 Red prussiate of potash..... 6 drachms

No. 2.

Water ..... 5 ounces  
 Citrate of iron and ammonia.. 7½ drachms

Spread the white of egg evenly over the surface, and, when it has dried thoroughly, sensitize with solution made of equal parts of No. 1 and No. 2. When this is dry the porcelain is ready to be printed on. Place the film over the sensitized surface by using wax at each corner to keep it in position. It may then be printed in strong sunlight. There will be no need to remove the film to see how dark the image is growing, because with the above formula it will not print beyond a certain depth. Print for about half an hour. Then wash the porcelain for about 15 minutes in clear water.

Better results may be obtained by using

gelatine instead of the white of eggs. Formulas 1 and 2 will give a bluish picture, but if desired the following sensitizer may be substituted:

Water ..... 1 ounce  
 Silver nitrate ..... 50 grains

Print deep and tone in a gold bath. Images obtained from using the first formula will remain permanent. In printing on clock dials, etc., more care will have to be exercised. Do not use either egg or gelatine. Better use a piece of transparent film, the exact size of the negative to be printed from. This may be obtained by soaking a worthless glass negative in a solution made as follows:

A.

Water ..... 20 drachms  
 Red prussiate of potash..... 1 drachm

B.

Water ..... 20 drachms  
 Hypo ..... 1 drachm

As soon as the film is cleared of the image, sensitize it with the silver nitrate bath mentioned above, and place it in a rack to dry. By cutting out the shape desired with a sharp knife, the sensitized film may be removed from the glass and transferred to any solid support, and then printed. Of course, when the article to be printed on has a flat surface, glass plate negatives may be used instead of a film.

In stripping a film from a plate to transfer to some other surface, soak the plate in water about an hour. As the film is transparent, it will make no difference whether it stretches or not. If, however, it is desired to remove the film whole, the plate must be immersed 5 minutes in—

1.—Ether ..... 50 cubic centimeters  
 Alcohol ..... 50 “ “

When this coating is dry, place in  
 2.—Sulphuric acid.... 4 cubic centimeters  
 Water ..... 186 “ “

As soon as the film begins to loosen, lay a piece of clean white paper over it for a support and carefully separate both from the plate. It can then be transferred to the permanent support. Materials for the first formula can be obtained for a few coppers at any chemist's.—Exchange.

THE SELECTION OF A CAMERA.

I note in the April issue of RECREATION Mr. Earl Dunn, of Iowa Falls, Iowa, asks readers which 4 x 5 camera they consider the best for an amateur.

This is a difficult question to answer in its present form, as the inquirer does not state what scope he desires the camera to cover, whether he expects to use films or plates, or the amount of money he is prepared to invest in an instrument.

Assuming his inquiry to be general, I rec-

commend as a plate camera the Cyclone, manufactured by the Rochester Camera and Supply Company, Rochester, N. Y. This camera is cheap and easy of manipulation, and it embodies features which produce satisfactory results in the hands of the early amateur. If the inquirer is not already familiar with this camera, I refer him to the catalogue of the Rochester Camera and Supply Company, where a detailed description will be found. I have tried the camera under various conditions and find it most satisfactory for both snap shot and time exposures. The lens is arranged with 3 diaphragms and the shutter speeded to what I estimate 1-30 second, which is rapid enough for ordinary snapshot work. This is one of the always ready kind, admitting of 12 exposures without reloading.

I would impress on any purchaser, however, the importance of securing the best instrument his means will allow. If he can, even at a sacrifice along other lines, possess one of the folding cameras of standard make and modern design, the results, after a little experience, will be most gratifying. A first class lens, convertible as a telephoto, used in connection with a box admitting perhaps 15 inches draw, and a reliable shutter allowing an exposure of at least 1-100 or 1-150 part of a second, is all that can be desired in the way of an up-to-date outfit for the amateur.

I once read of a pupil in whose hands an expensive violin was placed. He entered a class of 8 and at the expiration of a given period was second in the class of his associates who had equal advantages but poorer instruments. Talent in that case may have played an important part; but I think it demonstrates what may be attained by the use of first class equipment at the start. The best is none too good, even for a beginner.

Grover G. Hollister, Kingston, Pa.

#### PRINTING CLOUDS.

How are clouds printed in a picture where there is a blank sky?

Why is it better to do your photographing in the morning?

Is there any remedy to prevent Monarch Matte from curling up so tight?

I was told that my negatives were not bright enough. What was meant by that?

Is there any way to remove green tones?

W. N. Lockrow, Schenectady, N. Y.

#### ANSWER.

Clouds are printed into a blank sky by using a second negative taken for the clouds only and ignoring everything else. First print the landscape, masking everything above the sky line; then mask the

landscape and print in the sky from the cloud negative.

It all depends on the effect wanted, as to when is the best time of day to take pictures. In the morning and evening the light is much softer and gives a better atmosphere to the photograph. The shadows are more gradual and there are fewer sharp contrasts. During the middle of the day, especially if it is clear, objects will have a harder look, contrasts will be decided and the atmosphere and distance will not be so correct.

Before toning lay the paper flat on the bottom of a tray, and wet with just enough water to cover the paper. While keeping the paper flat, drain off the water and stand tray on edge 10 or 15 minutes. If this does not stop the curling, put the paper in water 20 parts and alcohol 30 parts, for a few minutes.

The negatives were probably either fogged or over exposed and therefore lacking in contrast; compare the appearance of negatives made on a bright summer morning after a shower with those made on a foggy fall morning; that will give some idea of the difference.

Green tones in P. O. paper are due to too little toning in the gold bath. In gaslight paper too much potassium bromide in the developer will give live green tones.—  
EDITOR.

#### CARBON PRINTING.

Please explain the enclosed paragraph which I cut out of a photographic journal:

"A carbon print is a paper coated with a gelatine solution containing a pigment of the desired color, which, after drying, is sensitized in a bath of bichromate of potassium. Carbon printing is one of the easiest processes for producing prints from negatives without silver."

D. G. Terwilliger, Long Branch, N. J.

#### ANSWER.

The carbon process is too long to describe here in detail. A handbook may be had from Anthony & Scovill, 122 Fifth avenue, New York. The paper or tissue is bought in the color desired. It is sensitized in a solution of bichromate of potash, usually 5 per cent., for a few minutes and then dried. When dry it is exposed under the negative in the shade. When printed it is placed in cold water and squeegeed to a temporary support paper on prepared rubber, etc. Then the tissue and support are placed together in hot water, about 110 degrees, and the backing of the tissue is stripped off. The image appears from laving and washing the tissue. The action of light on bichromitized gelatine is to harden it and render the parts most acted on more or less insoluble in warm water. When the image is sufficiently clear, the

tissue is placed in an alum bath and after 2 rinsings of cold water, is squeegeed to the final support and left to dry; when the temporary support is stripped off.—EDITOR.

#### EDINOL AND ACETONE SULPHITE.

Among other things with which I have been lately experimenting are edinol and acetone sulphite, and for my own work I have found their use limited. Acetone sulphite as a substitute for sodium sulphite gives little if any advantage. It is more soluble but no more stable. Being an acid sulphite, it requires more alkali to neutralize it, and it is much more expensive than the sodium salt. As a preservative it is no better than oxalic acid. As a restraining agent for over exposed plates it prolongs development, but with the disadvantage of giving negatives a flat, gray appearance, even when development is carried far; and the resulting negatives make poor prints. I find it useful, however, in developing papers of the Cyko class.

Edinol I find as good for plates as any of the newer developing agents, and better than some, but like all of them, it is far inferior to pyro, as regards the printing quality of the negative. For developing X-ray negatives it is good, as it does not stain even in the prolonged development that is sometimes necessary; but by increasing the sodium sulphite I can do as well with fresh pyro developer.

R. L. Wadhams, M. D., Wilkes-Barre, Pa.

#### SNAP SHOTS.

Is it possible to make a stock solution of hypo and alum that will not deteriorate?

How long will a developer composed of 80 grains amidol and 200 grains sulphite of soda keep in solution? How much water should be used to dilute it?

How long will unfixed prints keep if stored in a light-tight box?

H. S. Bird, Amherst, N. S.

#### ANSWER.

Unfixed prints will keep a reasonable length of time; not, however, so long as the paper will before exposure. If kept too long, say, more than a few weeks, they will have the appearance of under exposure when finished.

Solutions of hypo and alum will keep several weeks if made with clean water and corked tight.

A good formula for amidol developer is as follows:

Amidol .....	30 grains
Sodium sulphite (dry).....	235 grains
Carbonate soda (dry).....	100 grains
Bromide potassium.....	3 grains
Water .....	8 ounces

For use on paper take  $\frac{1}{2}$  to 8 ounces of water.—EDITOR.

I saw in September issue a plan for preserving negatives. My plan is as follows: My camera is a  $6\frac{1}{2} \times 8\frac{1}{2}$ . I use an envelope for each negative,  $6\frac{3}{4} \times 8\frac{3}{4}$ , open at one end. I put up 16 prints from negatives I wish to preserve and photograph them. This gives me a copy of each, about  $1\frac{1}{2} \times 1$  inch. I paste one of these small copies on the upper left corner of the envelope in which I place the corresponding negative and stand about 60 of these envelopes on end in a box that is one inch lower than the negatives, to allow plenty of light. The box is about 2-3 full. This allows the negatives to tip from one end of the box to the other. When I want a certain negative I tip them all toward me, then let them drop back from me one at a time till the picture I am looking for, pasted on the upper left corner of envelope, shows up, and I have the negative wanted. I number each negative and put each class in a separate box.

Will some reader of RECREATION tell me the best way to enlarge negatives; for instance, to enlarge  $6\frac{1}{2} \times 8\frac{1}{2}$  to  $16 \times 18$ .

S. N. Leek, Jackson, Wyo.

I saw in RECREATION a recipe for a preparation to dress the outside of a leather-covered camera. I have lost my copy and would be grateful if you would reprint the receipt.

Mrs. Sophia Sykes, Gloversville, N. Y.

#### ANSWER.

A good dressing for cameras and carrying cases is Glycerale liquid shoe blacking. Apply freely, allow it to dry and polish with a woolen rag.—EDITOR.

In place of the cleansing fluid recommended on page xxxiv of September RECREATION, I suggest gasoline. It will positively work.

The formula for removing varnish from negatives, page xxxvi, is good but results will be disagreeable to hands and nose. Substitute what is known as banana oil, which is the best known solvent for varnish. It may be found in any paint supply house.

Juen Doux, Utica, N. Y.

William Burton, of 1016 Arsenal street, St. Louis, Mo., is organizing an association of amateur photographers, to which all amateurs living in the State of Missouri are eligible. His scheme is comprehensive and practical, and all persons interested in amateur photography should communicate with him at once.

*If it isn't an Eastman, it isn't a Kodak.*

Broader in scope than anything heretofore attained in pocket photography.

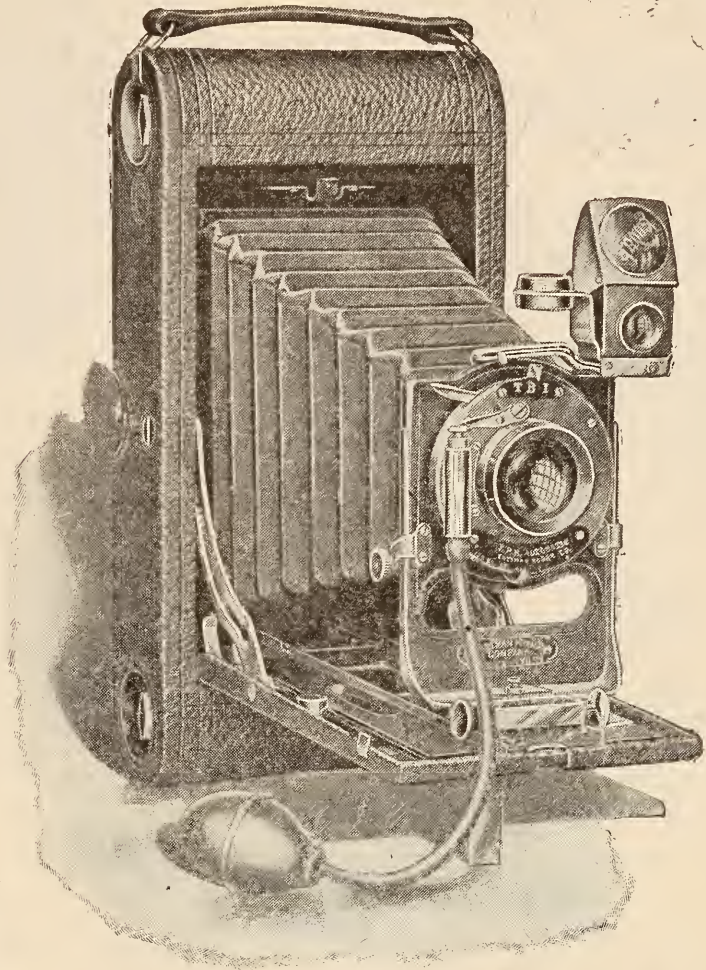

*The*  
**New 3A**  
**Folding**  
**Pocket**

# KODAKS

Pneumatic release automatic shutter with iris diaphragm stops, high speed rectilinear lens, rising, falling and sliding front, combined reversible finder and spirit level, tripod sockets for vertical and horizontal exposures. An instrument that provides, in pocket form, every detail of the equipment required by those who know photography best. Loads in daylight for 2, 4, 6 or 10 exposures as desired.

**Pictures, 3¼ x 5½ in. Price, \$20**

"Kodakery" means photography with the bother left out, means daylight development, fewer chemicals, better pictures.

**EASTMAN KODAK CO.**

**Rochester, N. Y.**

*Ask your dealer or write us for  
booklet of Christmas Kodaks.*

## New Camera for Holidays

# No. 3 Weno Hawk-Eye

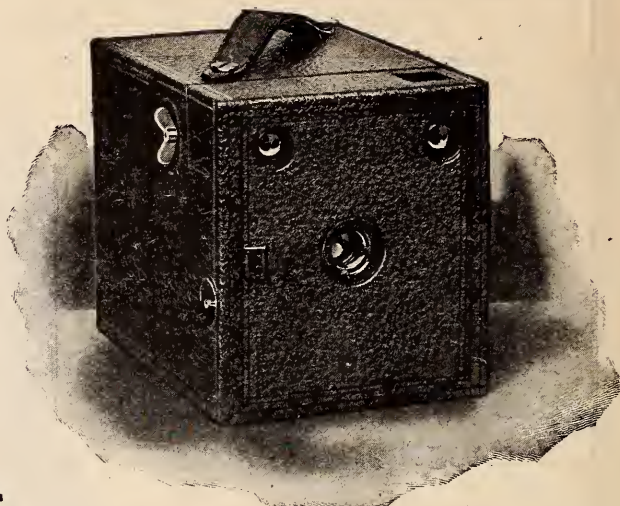

**POPULAR SIZE**

**POPULAR PRICE**

**EASY TO OPERATE**

**EVER READY**

Makes picture  $3\frac{1}{4} \times 4\frac{1}{4}$ . Sells for \$8.00. Fitted with Automatic Shutter, Iris Diaphragm, Universal Focus Lens. It's **EVER READY**. Uses Perforated Daylight Loading Film, also Eastman Cartridge Film.

**No. 3 Weno Hawk-Eye, \$8.00**

Full description in Hawk-Eye Booklet.

**BLAIR CAMERA CO.**

**Rochester, N. Y.**

### AN IMPORTANT OFFER

For 2 Yearly Subscriptions to **RECREATION**  
I will send you

#### A RIFLE WICK PLUG

Made by **HEMM & WOODWARD**, Sidney, Ohio, 30 caliber up to 50 caliber.

OR

#### A SHOT GUN WICK PLUG

20 gauge up to 10 gauge

For 3 Yearly Subscriptions to **RECREATION**  
A Pair of Shot Gun Wick Plugs

20 to 10 gauge.

Sample copies for use in canvassing furnished on application.

Address **RECREATION**, 23W. 24th St., N. Y. City

The best way to get rid of old silver stains is to remove the varnish with spirit, and then rub the stains gently with fine pumice powder to remove the iridescent appearance. Finally place in a fresh, strong solution of hypo, until the stains disappear. The length of time depends on the age of the stain. The above method will remove stains 5 years old, but it requires 4 or 5 hours' fixing.—Exchange.

I have received the Ithaca gun and like it much. I can not see how you can give such a fine gun for the small number of subscriptions you ask.

A. J. Rausch, Lawrence, Mass.

## For Golf & Tennis Players

# "PRESTO! — CHANGE!"

ATTACHABLE EYEGLASS TEMPLES



Eye Glasses into Spectacles. Spectacles into Eye Glasses

**BE PROTECTED!**

**DON'T BREAK OR LOSE YOUR GLASSES IN EXERCISE, WIND AND STORM**

Can be attached by anyone

Send thickness of lens when ordering by mail

Price in Nickel 50c. a pair.

Gilt 75c. a pair.

Gold Filled \$1 a pair.

Solid Gold \$2.50 a pair.

Established 1842

GALL & LEMBKE, Dept. C, 1 W. 42d St.

21 Union Sq., New York

Send for Circular

PATENTED  
July 17<sup>th</sup> 1909

GLASSES WITHOUT TEMPLES

GLASSES WITH TEMPLES

COVERED BY  
Foreign Patents



## The Pack and the Picture— A Very Simple Matter.

Amateur photographers have received the new PREMIO Film Pack with almost extravagant praises. It meets the conditions of the outdoor picture maker as nothing else has ever done. Whether you use a PREMIO Plate Camera or a PREMIO Film Camera, it opens the easy way to photography;—a working outfit that is unequalled for simplicity and convenience.

# The PREMIO Film Pack

## DAYLIGHT LOADING.

As flat as a handkerchief in your pocket when not in use, as easy to load in daylight as shutting a book; it is unequalled for effectiveness. Carrying twelve non-curling, orthochromatic films; successive exposures are made by pulling out the numbered black paper tabs. The last tab seals the package light tight. Adapted to  $3\frac{1}{4} \times 4\frac{1}{4}$  and  $4 \times 5$  Cameras, the PREMIO Film Pack meets successfully every photographic condition. See it at your dealer's or write for particulars contained in the *Premo Year Book*, free.

**ROCHESTER OPTICAL CO., Dept. 209, Rochester, N. Y.**

# When using

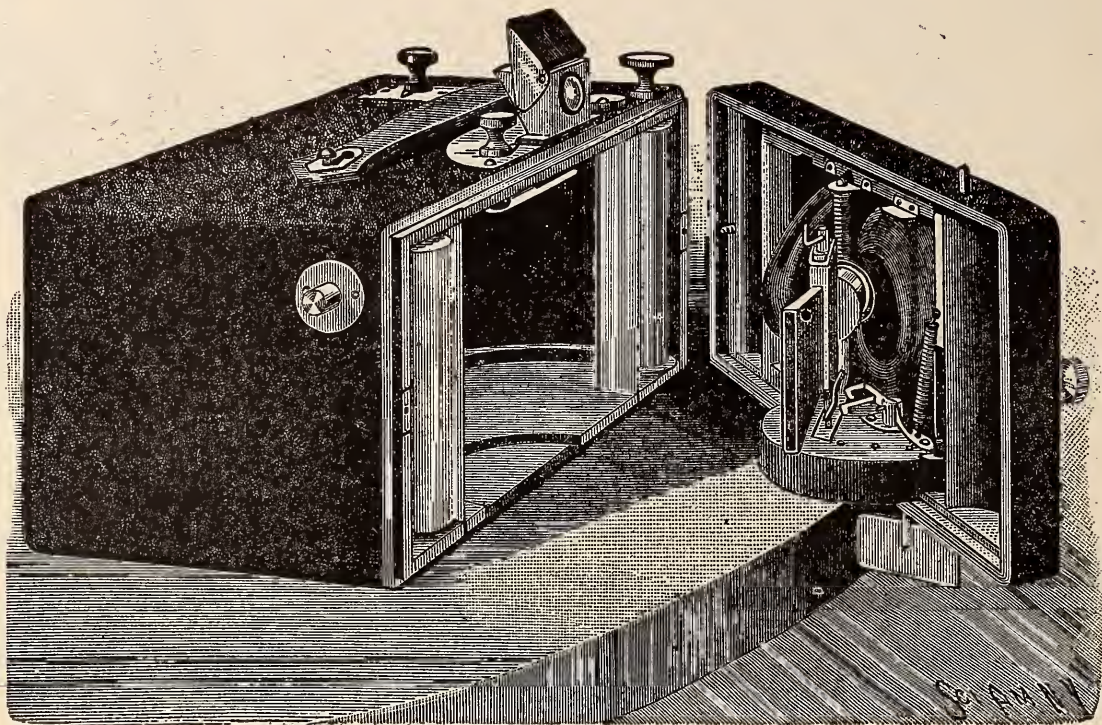

Front of camera removed, showing flat opening in the tube attached to the back of the lens, and through which, as the lens revolves from side to side, the exposure sweeps over the film.

an ordinary limited-view camera, how many times you want to get in your picture just a little more than your camera will get on the plate. It may be an object that will make the view more artistic, or perhaps is something that is really necessary to make the picture complete, but, *you want it!* If you place your camera farther back, you then reduce the size of the objects in your picture, besides the difference in the point of view *changes the whole picture*. If you use a wide-angle lens you will get more in your picture, but the whole picture is changed by the violent perspective of the wide-angle of the lens. *You haven't got what you want!*

If you get a larger camera, you merely get the same scene larger in size but no larger in *scope*, besides, you have the expense of larger camera, larger plates, and extra weight to lug around.

There **is** a camera which will not only take the ordinary size of picture, but if you want to get more view on the *sides* (not more *blank sky* and *out-of-focus foreground*), you can make the photograph (the original one being 5 x 4) either 5 x 6, or 5 x 8, 5 x 10, or 5 x 12, and this camera *the only one* which will do it, is the



# AL-VISTA PANORAMIC CAMERA

Our  
Superb  
Catalogue  
Free  
on  
request

Mention  
RECREATION.



THIS IS A SCENE FROM LINCOLN PARK, CHICAGO, SHOWING THE 180° THE "AL-VISTA" TAKES IN ONE SWEEP.

The swing-  
ing and re-  
volving lens  
does it—you press  
the button, and in  
an instant it records  
everything within its sweep  
of nearly 180 degrees—**half  
a circle!** If you owned a regu-  
lar 10 x 12 camera, think of what  
you could save if, instead of using a  
full 10 x 12 plate every time, you could  
use only just so much of a plate as you had  
need of for each individual picture, and could  
use the remainder for other views! That is just  
what you can do with an "Al-Vista."

Suppose you had a Model "5-B," which takes pictures 5 inches wide, by  
from 4 up to 12 inches long; the exposures on your roll of film *might* be first,  
5 x 4, then 5 x 12, then 5 x 8, then 5 x 4, and so on, depending upon just  
the length of each view you happened to *want* to take.

How often you find yourself on some high place, with a view just in front  
of you that would not be at all interesting as an ordinary camera would take  
it, but the *whole sweep of which view* would make a delightful picture; and  
you long for a camera which *will* record the whole view. Prevent these chances  
of disappointment, these chances of taking views which none of your friends  
will have anything to equal, by getting an "Al-Vista" Panoramic Camera.

**THE MULTISCOPE & FILM CO.**  
136 Jefferson Street, Burlington, Wis.

---

# SLEEP

IS TIRED NATURE'S  
SWEET RESTORER

After a hard day's tramp, you must have

**A Good Night's Rest**

in order to fit you for the next day's work. Better to sleep on a good bed without your dinner, than sip at a banquet and then sleep on the cold, hard, wet ground. You can get

**A Recreation  
Camp Mattress**

of rubber, with valve for inflating, made by the Pneumatic Mattress Co., and listed at \$18.

For 10 Yearly Subscriptions to  
**RECREATION**

---

---

*Send for Sample Copies*

Address RECREATION, 23 West 24th Street, New York

# It's Not a Toss-Up



*as to the quality of pictures made with a*

## KORONA Camera



GUNDLACH-MANHATTAN OPTICAL CO., 730 So. Clinton Ave., Rochester, N. Y.

## “THE KORONA and the FILM PACK”

is the title of an artistic  
little folder which tells how  
the **KORONA** can be  
c o n v e r t e d i n t o a

### Focusing Film Camera

by the use of the

## FILM PACK ADAPTER

Do you want it? Your name, please.

Mention RECREATION.

*"Kodakery means photography, with the bother left out."*

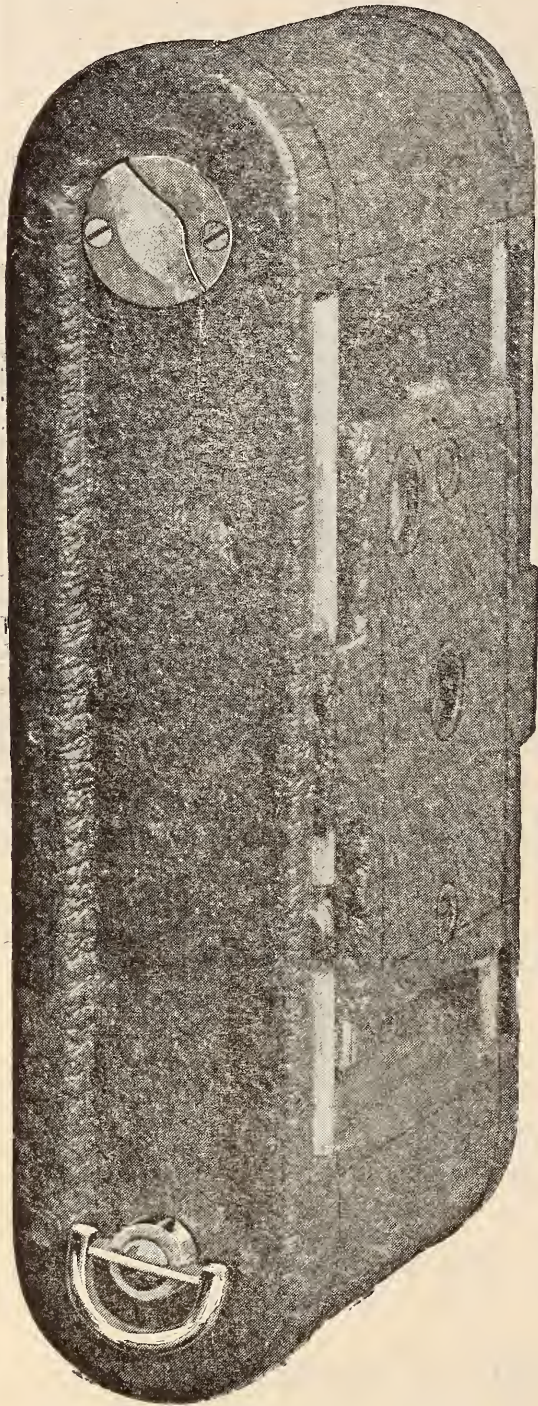

## *A Holiday Hint*

**The No. 0  
Folding  
Pocket  
KODAK  
\$6.00**

The watch in your pocket is, no doubt, as accurate as the family clock—likely more accurate.

The No. 0 Folding Pocket Kodak is as accurate as cameras of ten times its bulk. It's for the pocket, almost for the vest pocket, yet loads for 6 or for 12 pictures,  $1\frac{5}{8} \times 2\frac{1}{2}$  inches. Has meniscus lens, Eastman Automatic Shutter, for time exposures and snap-shots, set of three stops and view finder. Made of aluminum, and covered with the finest seal grain leather. It has the "Kodak Quality."

**KODAKS, \$5 to \$75. BROWNIE CAMERAS, \$1 and \$2.**

**KODAK DEVELOPING MACHINES, \$2 to \$10.**

**EASTMAN KODAK CO.**

**ROCHESTER, N. Y.**

*Ask your dealer or write us for  
the Kodak Christmas Book.*

## PHOTOGRAPHIC DOUBLES.

Photographs, wherein one object appears in 2 places in the same picture, are called doubles. They may be made from 2 or more negatives by combination printing, or, from one negative made by exposure under unusual conditions. There are several methods, but the every day amateur can readily make, with any hand camera, the same figure appear twice on one plate by fitting a lidless cigar box over the front of the camera, the bottom of the box having been pried off, cut in half and replaced with hinges, so as to form folding doors. Slip this box over the camera front, leaving a space of 2 inches between the lens and the folding doors. Open the right hand door and the print will show everything to the right of the center of the lens, one-half of the plate being unexposed. Close this door after exposure, transfer the subject to the left and open the left hand door.—Exchange.

Mike went to the telephone: "Is this Miller & Jones?"

"Yes."

"Well, you sind up 6 bags of oats, and hurry up with 'um."

"All right; who are they for?"

"Arrah, now, don't you get gay; for the horses, to be sure," and Mike rang off.—Exchange.

I consider a file of RECREATION indispensable to any sportsman's library.

Fred. E. Whipple, Black River, N. Y.

DO YOU WISH TO IMPROVE YOUR SHOOTING? IF IT IS AS GOOD AS IT CAN BE, DO YOU WISH TO KEEP IT SO? IN EITHER CASE, THE J. C. HAND TRAP WILL BRING WITHIN YOUR REACH THE FULL ADVANTAGE OF A SHOOTING RANGE. THESE TRAPS WILL SUCCESSFULLY THROW ANY OF THE CLAY TARGETS NOW IN USE, GIVING A LIFE LIKE REPRESENTATION OF A BIRD IN FLIGHT. I WILL SEND YOU A J. C. HAND TRAP FOR 5 YEARLY SUBSCRIPTIONS TO RECREATION. SEND IN YOUR CLUB NOW, AND IMPROVE ON YOUR SHOOTING.



## ANSCO and CYKO

ARE PRIME FACTORS  
IN THE PRODUCTION OF

## PERFECT PICTURES

No other similar products  
have so great a latitude in  
exposure and development

**ANSCO**, The new daylight loading film  
fits all standard makes of film  
cameras.

**CYKO**, the paper that prints by any  
light. Seven different grades.  
No dark room required.

**Cyko Manual and AnSCO Booklet  
sent on Request**

ASK YOUR DEALER OR  
**THE ANTHONY and  
SCOVILL CO.**

122-124 Fifth Ave., N. Y.  
Atlas Block, Chicago



## A GOOD FAST LENS

is the principal factor in **High Speed Photography**. There are **poor**, fast (?) lenses and **One Good Fast Lens**. So be sure you get **A GOERZ**.



Series III F. 6<sup>s</sup>. Series I<sup>B</sup> F. 4<sup>5</sup> to 5<sup>5</sup>.

**C. P. GOERZ, Room 27, 52 East Union Square, New York.**

### OIL PORTRAITS ON APPROVAL.

If you will send me a photo of yourself or a friend and state color of hair, eyes and complexion I will paint and send you on approval a miniature oil or pastel portrait.

Canvas 6x8 or 8x10 inches, \$10.00

Canvas 10x12 or 12x14 inches, \$15.00

Z. EMMONS, 58 West 104th St., New York.

Reference: Mr. G. O. Shields.

### LANTERN SLIDES COLORED SKILLFULLY AND ARTISTICALLY

FOR

**Lecturers, Teachers and others**

I refer by permission to the Editor of RECREATION

**MRS. C. B. SMITH**

**The Ansonia, 74th St., & Broadway,  
New York City.**

I herewith send you \$1 for which please continue sending me RECREATION. The idea of that magazine ceasing its friendly rounds to this house does not strike me favorably.

E. L. Dupuy, Blackstone, Va.

### A SUGGESTION FOR CHRISTMAS.

Have you commenced to think of Christmas presents? If so, here is a suggestion.

A yearly subscription to RECREATION furnishes one of the most delightful, instructive, entertaining Christmas presents you can possibly give a man or boy who is interested in nature, in fishing, shooting, amateur photography; or, who is fond of lakes or the rivers.

Many of the presents which people give their friends afford pleasure only for a few days, or weeks. A subscription to RECREATION means solid comfort a whole year. It reminds your friend 12 times during the year of your kindness and generosity. There are many men and women who for 5 years past have annually sent in long lists of names of friends, accompanied with a check in order that these friends might be made happy a whole year. Would it not be well for you to adopt this plan?

Try it and see how grateful the recipient will be.

In answer to my ad in a late number of RECREATION, which you so kindly inserted for me announcing that I had a boat for sale, I received 48 letters. If this does not prove the superiority of RECREATION as an advertising medium, I give it up.

Harry Terhune, Middletown, N. Y.

IN ANSWERING ADS PLEASE  
MENTION RECREATION.

# "Century" Cameras.

**PERFECTION IN CAMERAS  
IS ONLY REALIZED  
IN THE CENTURY**

Not only perfect plate Cameras, but they are equally adapted for Day-light Kodak Film, or Film adapter for Cut Sheet Films.

**"CENTURY QUALITY"**

is the result of twenty years' practical experience. Our catalogue tells about this great quality. Can be obtained free from all dealers, or by mail direct.

**Century Camera Co.  
ROCHESTER, N. Y.**

## WANT A REEL?

You can get one for nothing.  
Or at least for a few hours' work.

Send me

15 Yearly Subscriptions  
to  
**RECREATION**

and I will send you

**A TALBOT REEL**

Listed at \$20

Made by W. H. Talbot, Nevada, Mo

This is one of the finest pieces of fishing tackle ever made. It is built like a gold watch. Equal to any Kentucky reel you ever saw.

**In Tournaments, Always a Victor  
Among the Angler's Treasures, Always the Chief**

I have but a few of these reels in stock and this offer will be withdrawn as soon as the present supply is exhausted.

Sample copies of RECREATION for use in canvassing furnished on application.

# COXIN

Patented  
in all  
Countries.

Trade Mark.

## Does Away with the Dark Room

The drawback of Photography was the dark room. It meant space, space often valuable in small houses. It meant unpleasant hours spent in developing in semi-darkness, groping about, knocking over things, and losing one's temper. It meant that no developing was possible away from the dark room. A recent discovery by a German chemist enables you to

## Develop Your Plates and Films IN DAYLIGHT

The result you got in darkness you get with Coxin in daylight. It is not a colored developer, but is used with any developer, and may be used over and over again.

The sales of Coxin in Europe have been enormous.

**No Amateur Photographer can  
afford to be without it.**

"Coxin" (put up in neat flasks), per flask . . . 50c.  
"Coxin" Film Boxes (Patented). The simplest of all—the least expensive—development always in sight. Price . . . 50c.

"Coxin" Changing Bag should be used in changing plates from the holder. Made only by us. Ask your dealer for Bag.

**TRY A SAMPLE**

Sold by all Druggists and Photo Dealers. If they cannot supply, will be sent to any address on receipt of price.

**AMERICAN COXIN CO.**

108-110 West 11th St., New York, U.S.A.

## A VACATION. AN IDYL.

C. C. HASKINS.

A fisher afloat in his light Racine  
Went forth to battle a bidden foe,  
And this was his song on the rippling wave,  
His taunt to the monster that lay below:

As knights of old their gauntlets flung.  
I dare thee from thy castle dark.  
I fight for fame, thy life I seek,  
Come forth, and brave one tilt with me,  
Or I will brand thee coward—knave!  
I fling my shining lure afar;  
My Bristol light thy strength shall try,  
My silken line shall guide thee here,  
My Shakespeare sing thy requiem.

His barque sped lightly o'er the foam;  
With glistening guns the waves seemed  
crowned.

The sun with clouds played hide and seek,  
Now bright, now hid. The gentle breeze  
Blew soft as from my lady's fan.  
The rustling leaves swift races sped,  
Or whirling, waltzed in woodland through,  
While trustful deer looked tamely on,  
Nor feared the wily huntsman's guile.  
Afar the loon laughed out in glee,  
The heron waded by the shore  
And sought a meal from grass or foam;  
While in the marsh, with echoing thud,  
The bitter'n phantom stakes were driven.  
Bright plumaged birds, swift winged their  
flight,

Across the lake or through the trees;  
The wolf's coarse howl, the crow's hoarse  
caw,

The eagle's piercing scream on high,  
Discordant broke the harmony.

"Thou art a coward, craven, sneak!"  
The knight broke forth in thund'ring  
speech,

"'Twas said of thee thou wer't not weak.  
'Tis false; or come within my reach."  
As if the words had pierced his ear  
And roused the quiet of his mind,  
A musky darted from his lair  
To seize the lure in anger blind.

The strife is on! a fight for life,  
For freedom, home and liberty,  
This, in the crystal depths below,  
For fame fought he above the wave.  
Now spring good Bristol like a bow!  
Sing Shakespeare, trill thy sweetest song,  
Yet check this wild, this mad career!  
Flushed knight, he's worthy of thy skill,  
He'll try the virtue of thy nerve!

"Ah! woe is me, the line slacks down,"  
The angler cried in savage tones,  
He's won the fight—the hero's gone!  
A broken line, all hope dispelled,  
This, then, the record, blasted faith—  
An angler's luck—farewell, brave knight,  
I own defeat, thou'st won the fight.

What! still art there? Is that the game?  
And thou wert only sulking then!

Fly swifter reel, oh! cunning fox,  
A racer now, a rush, he comes,  
Then turns! now sings again the reel,  
The line's nigh gone; a few more turns,  
He'll win his life and liberty,  
Check, check his speed or all is lost.

He feels the curb, but still exerts a strength  
That thrills the angler's nerves; his breath  
comes quick.

Despite his firm closed lips and steadfast  
gaze,

A lurking fear is there—a wish 'twere done,  
And in the boat the prize were safely lain.

"Thank heaven!" he cried. "I've checked  
that run at last;

But three more turns of line are on the reel.  
He drags like any log; his strength is gone,  
Ah, victory! the glorious prize is won,  
And I have conquered water's doughty  
knight!"

But once again his strength seems now re-  
newed,

And once again he strains for added line,  
While upward to the surface with a spring  
He leaps, like any well trained acrobat  
From out his native element and shakes.  
With wide ope'd mouth and gills that look  
afame,

To rid himself of that which holds him fast.

Thus, running now, then leaping high again,  
And scattering watery rainbow gems afar,  
The monarch of the wave at last subdued,  
Like some wild captive savage, doomed to  
die,

Is led by slow and solemn pace along,  
Then trembling lies beneath the conqueror's  
gaze.

And the angler bows low  
To the prize he has won,  
And he thinks, as he kneels,  
Of the spirit that's gone.

No coward art thou; thou art brave as the  
best.

Thy name shall be honored, a rainbow thy  
crest.

Swift swimmer, deep diver, high leaper, thy  
fame

Shall be higher exalted, extolled be thy  
name.

We will champion thy cause like a true  
brother knight,

With the pen or the sword will we challenge  
the fight,

May the ill sounding names thou hast borne  
heretofore,

In the deep waves be lost to be heard never-  
more.

"Mah chil'n," said the Rev. Washington  
Lincoln Gardner, fervently, "de wise vih-  
gins, wid de oil to buhn, 'xemplifies de  
Baptis' chu'ch! Bress de Lawd for Mist'  
Jawn D. Rockumfeller!"—Life.

IN ANSWERING ADS PLEASE  
MENTION RECREATION,



# Did You Ever Know

## That Improper Food Often Causes the Liquor Habit?

It's a great proposition to get rid of a taste for liquor by changing food.

Improper food and stimulants like coffee and tea create unnatural appetites. The one who eats only proper food is normal in health and therefore normal in appetite.

By way of example take the case of a well-known business man of Lowry City, Mo., who says: "About three years ago my appetite failed me and my food disagreed with me. I got weak, nervous and dull and entirely unfit for business. Then like a fool I went to taking liquor to stimulate an appetite.

"For a time this worked well and I thought I had found a simple remedy, but I noticed I had to take more all the time and before long I found that I could not get along without the whiskey and I was in a pitiable condition.

"I tried to quit but it seemed impossible, as I needed nourishment and my stomach rejected food, and the more whiskey I drank the worse I got. I kept fighting this battle for more than two years and almost gave up all hope. Then I noticed an article about the food GRAPE-NUTS and concluded to give it a trial.

"I found I could eat GRAPE-NUTS with a relish and it was the first food that I found nourishing me in a long time. Soon my stomach trouble stopped, my appetite increased and then the craving thirst relaxed until all desire for drink was gone.

"I have used GRAPE-NUTS now for more than a year and I am now entirely strong and robust, entirely cured from drink and able to work hard every day. My gratitude for GRAPE-NUTS is unspeakable, as it has saved my life and reputation." Name given by Postum Co., Battle Creek, Mich.

A  
Free  
Sample  
of  
Delicious  
GRAPE-NUTS  
Food sent  
to  
any address  
upon request.

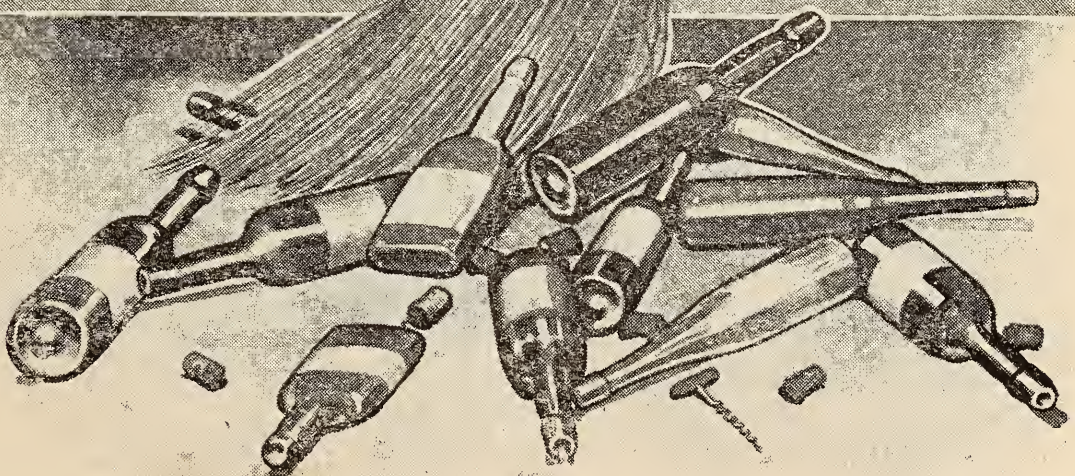



H. J. TILLOTSON, M. D.  
The Master Specialist of Chicago, who Cures Varicocele,  
Hydrocele, and treats patients personally.  
Established 1880.  
(COPYRIGHTED)

manent. My consultation will cost you nothing, and my charges for a perfect cure will be reasonable and not more than you will be willing to pay for the benefits conferred.

**Certainty of Cure** is what you want. I give a legal guaranty to cure or refund your money. What I have done for others I can do for you. I can cure you at home.

**Correspondence Confidential.** One personal visit at my office is preferred, but if it is impossible for you to call, write me your condition fully, and you will receive in plain envelope a scientific and honest opinion of your case, Free of charge. **My home treatment is successful.** My books and lectures mailed free upon application.

**H. J. TILLOTSON, M. D., 140 Tillotson Bldg, 84 Dearborn St., CHICAGO**

# Varicocele Hydrocele

**Cured to Stay Cured in 5 Days,  
No Cutting or Pain. Guaranteed  
Cure or Money Refunded.**

**VARICOCELE.** Under my treatment this insidious disease rapidly disappears. Pain ceases almost instantly. The stagnant blood is driven from the dilated veins and all soreness and swelling subsides. Every indication of Varicocele vanishes and in its stead comes the pleasure of perfect health. Many ailments are reflex, originating from other diseases. For instance, innumerable blood and nervous diseases result from poisonous taints in the system. Varicocele and Hydrocele, if neglected will undermine physical strength, depress the mental faculties, derange the nervous system, and ultimately produce complicated results. In treating diseases of men I always cure the effect as well as the cause. I desire that every person afflicted with these or allied diseases write me so I can explain my method of cure, which is safe and permanent.

## SALUT AU CHAUFFEUR.

(Supposed to Have Been Written by  
Walt Whitman.)

A song of the automobile! A carol of the festive Red Devil! A yodel of the goggle eyed chauffeur, sitting aplomb in the midst of devastation! A chant of speeds, tires, tonneaus, spark plugs, poppet valves, collet pins, high clutches, this shall be my morning romanza!

See the locomokomobile scooting through my poem! The waft and aura of gasoline floating through my morning romanza!

The squawk and scatter of chickens, the squeak of the old rooster who didn't jump quick enough.

See! The robust Manhattanese, attired in the usual costume, agile, elusive, profane just at present, getting out of the road for dear life! The impotence of his cuss words! The uselessness of the protests of the apoplectic old lady!

See! The over curious calf standing in the middle of the road; the dog, imprudent, unforeseeing; the two instantly transformed into veal or sausage.

*Allons, mes enfants!* Whoop!

See! The festive chauffeur, rampant, chantant, jubilant, moving the lever to let the speed out another notch! *Libertad!*

See the wagon, the horses rearing and plunging! He is upon them. Crash! That was a good one! The friendly and flowing rustic, where is he?

I am not only the poet of the chauffeur; I do not decline to be the poet of the cop also.

See the suburban cop standing, ready to pinch those who break the speed laws! The locomokoko furious arriving, the chauffeur refusing to stop; the jigger, enraged, shooting the tire of the car; the tire punctured, the Red Devil stopped.

See the cop dragging the chauffeur before a police judge; the judge imposing a fine; the chauffeur, reluctant, paying it. *Justitia, ma femme,* I salute you! I perceive that once in a while you get there with both feet!

—Horace B. Matthews, in Life.

## MEXICAN OPAL AND SOMBRERO FREE WITH EACH SUBSCRIPTION TO RECREATION.

To anyone subscribing to RECREATION through me, I will send free a beautiful genuine Mexican Opal as large as a pea, together with a miniature Mexican Sombrero, made of silver and horsehair beautifully dyed. Arthur Thomson, Box 332, San Antonio, Texas.

The musical critic of a rural newspaper in Kansas referred to "Ave Maria," and the editor, who abhorred abbreviations, promptly corrected it to read "Avenue Maria."—New Haven Chronicle.

# Orangeine

## Good Health and Good Spirits Club

Established January 1st, 1900.

**Limit of Membership Now Increased From 1000 to 2000.**

**Applications Entered in Order of Receipt.**

*The present wide acquaintance with ORANGEINE proves that under intelligent and timely use, it quickly dispels all kinds of pain and promptly corrects common and seasonable ailments.*

The "**Orangeine Good Health and Good Spirits Club**" was formed for the purpose of mutual benefit and information.

**To Our Members:** The results of continued good health and quick rescue from pain and common ailments, are faintly indicated by a few selected experiences printed below.

**To Us:** Our Club has brought so much instruction and enthusiastic co-operation, that we have decided to double the membership, and have increased our facilities for properly caring for the same.

### CONDITIONS OF MEMBERSHIP.

Upon payment of \$5 annual dues, each member will receive, post paid, on the first of every month, for one year, a \$1 box of 35 Orangeine powders with our monthly letter. They will further receive, upon application, from our medical department full information as to the **uses, composition and results** of Orangeine, full instructions for special applications, and complete knowledge of Orangeine's power to relieve pain, prevent and cure common ailments, and dispel chronic conditions.

**Our Members Agree** to apply the Orangeine powders thus received (at far below our trade price) only for private use, and further, as may suit their pleasure and convenience, to thoroughly ventilate, wherever possible, their own experiences of comfort, health and protection through Orangeine.

***A Few Specimen Experiences, Selected from Three Days' Mail Showing the Never Failing Power of***

# Orangeine

(POWDERS)

**Promptly and Intelligently Applied, Under Our Simple Directions**

**To Quickly Dispel: Colds, Grip, Headache, Neuralgia, Fatigue, Nervousness, Indigestion, Stomach Upsets,** (temporary and chronic ailments), **and the "Half Sick," "Out of Sorts,"** conditions which often lead to serious sickness.

Mr. J. A. Waldron, Editor Dramatic Mirror, New York, who has used Orangeine several years, writes: "It helps me over hard places with a hand as light as a feather. For me it dispels Grip and Colds in winter, Hay Fever in summer, and keeps me in good condition always."

Mr. T. R. Timby, Brooklyn, N. Y., the distinguished inventor, writes: "In the interest of humanity, I am pleased to say that I am never without Orangeine, as I regard it a speedy cure for nearly every ill, and it should be in every one's reach by day and by night."

Mrs. R. Odell, New City, N. Y.: "It has been a God-send to me for I suffered untold misery for years, until I became acquainted with Orangeine a few months ago. I have not had a headache since I commenced to use it, and before I was hardly ever without a headache."

Mrs. Fanny G. Bartlett, East Windsor, Ct., in her 83rd year writes: "Orangeine is very sustaining for my years, and I have found it very helpful to friends who suffer from Hay Fever and Asthma, and really magical in recent cases of Neuralgia and Grip."

Hon. Wong Kai Kah, Imperial Chinese Commissioner at the St. Louis Exposition, says: "Orangeine has done me a world of good. My continual round of official duties calls for something to tone me up and keep me always in condition to perform all sorts of mental and physical effort. Always effective, easy to take, produces no other than the effect desired."

Prof. O. B. Supper, Dickinson College, Carlisle, Pa. "I have entirely escaped Hay Fever during the past two seasons. I have not had a cold for more than a year, thanks to Orangeine."

Mr. J. D. Wilson, 5 Trinity Place, Williamsport, Pa., says: "Orangeine has accomplished for me a relief that I thought was hopeless. While abroad, Orangeine kept me and my party immune from headache and all dyspeptic discomforts."

Mr. Shipley W. Ricker, Jr., South Berwick, Me.: "I am finding new uses for Orangeine every day, and am constantly recommending it to my friends."

Mr. Alonzo Williams, of New York City, says: "My wife and myself both use Orangeine, as we have have found it the best remedy for headache and neuralgia we have ever used."

Mrs. L. E. Woodson, Macon, Ga., says: "I would not be without Orangeine for anything. It has been used by the entire family and we are all devoted to it."

Hon. C. McClymonds, Atwood, Pa.: "Orangeine is certainly a splendid remedy in an emergency, and for colds and headache most efficacious in my experience, and among my neighbors."

Mr. Jas. T. McGauran, Jersey City, N. J.: "My wife has suffered with headache for five or six years; has tried nearly all kinds of remedies with only temporary relief. Orangeine gives her almost immediate relief."

Mrs. Lena Swain, 65 St. Stevens St., Mobile, Ala. "By the timely use of Orangeine I have not had a cold this summer."

*"An Orangeine Club Membership is the most valuable of all Holiday Gifts."*

**Trial Package Free** Orangeine is sold by druggists everywhere in 25c, 50c and \$1.00 packages. On receipt of request we will mail a 10c trial package FREE with full directions, composition and description of its wide human influences. Address "**ORANGEINE,**" Chicago, Ill.



## Indians of the Southwest

Where they live and how to get there—their homes, handicraft and ceremonies—an intensely interesting book of more than two hundred pages—written by Geo. A. Dorsey, Ph.D., Curator of Anthropology, Field Columbian Museum, an authority on the "Amerind"—profusely illustrated with half-tones from special photos—handsome cover in colors—sent anywhere on receipt of fifty cents—valuable for schoolroom or library. Address Geo. T. Nicholson, 1312 Great Northern Bldg., Chicago.

## PAROID ROOFING

"IT LASTS"

The most satisfactory roofing for camps. Each roll a complete roofing kit. Adapted to any roof in all climates. No paint required when first laid. Write us for samples and prices.

Mention RECREATION

**F. W. BIRD & SON**

MAKERS

East Walpole, Mass., U.S.A.

New York Chicago

## A CUTE DEER.

L. C. ELERICK.

The incident of which I write occurred many years ago. Eastern Iowa was then a wild country, with an abundance of game, especially deer and wild turkeys. Squirrels were so plentiful in the timber along the Des Moines river and its tributaries that the better class of hunters did not consider them legitimate game. Many sportsmen believed, even before RECREATION commenced its valiant fight for game protection, that the list of birds and animals, classed as game, might well be still further reduced. Indeed, some of us have about decided that we love all God's creatures better alive than dead.

At that time every fence rail, clump of underbrush and copsewood had its covey of quails or ruffed grouse, but hunters paid little attention to such small game. In fact many would not waste a load of ammunition on even a wild turkey, because the report of a gun might frighten a deer.

In those days, too, there were human brutes who hounded deer for a livelihood, and then, as now, this class was thoroughly despised by honorable sportsmen. I have often known hunters to watch runways, or crossings, and permit the nearly exhausted deer to pass unmolested and then kill the hounds as they went by. The hunter would perhaps go home without meat for supper, but with the consciousness of a good deed done I plead guilty.

My father was a great deer hunter, and always used a muzzle loading rifle. It seemed to me that no matter what the circumstances, whether the deer was running or standing, in thick brush or in the open, when Father's rifle cracked the venison was ours. He naturally wanted me, his eldest son, to follow in his footsteps, and when I was 14 years old he bought me a small rifle. Needless to say I was proud.

One evening in November, shortly after I became the owner of the little rifle, I was out, boylike, for anything that wore hair or feathers. Passing along a cow path, through a hazel copse, my eye caught a movement in the thick brushes some 20 paces to my left. Instantly I was all attention, and plainly saw a deer's head, with magnificent horns, being slowly and cautiously lowered to the ground. The motion continued until the head lay flat on the ground, with the horns apparently resting on the buck's neck. He evidently thought he was hidden, and lay motionless except for an occasional slow wink. I moved sideways slowly and carefully, until my gun—which, though small, was heavy for me—rested against a hickory sapling. Then waiting a little for my heart to quit jumping up and turning over, I drew a bead on the deer's eye and fired. The deer never got up. I went home the proudest boy in all Iowa. Those grand antlers lay for years, unmounted, about the paternal homestead in Van Buren county, Iowa.

The best value you ever received, so send 10 cents at once

# THREE SPLENDID BOOKS

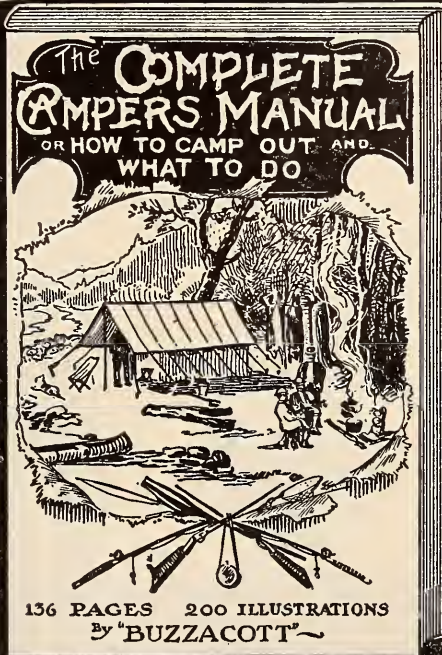
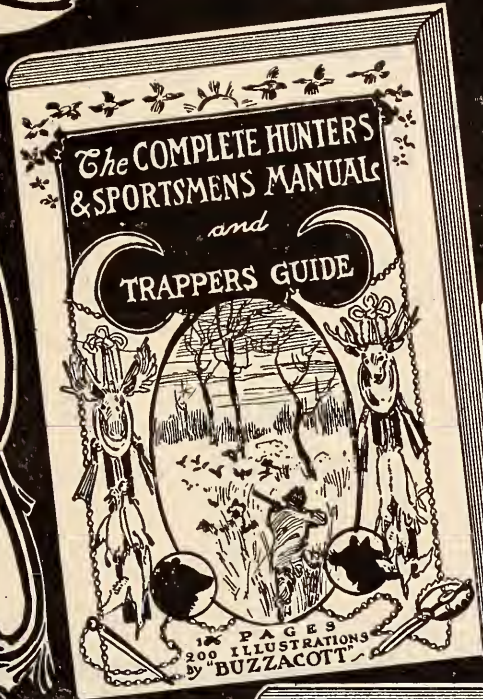

**EACH BOOK**  
136 PAGES  
200 ILLUSTRATIONS

“Fairly Bristles”  
with facts and information from cover to cover

“GLITTERS”  
WITH PICTURES

THOUSANDS OF  
FACTS, HINTS,  
POINTERS  
WRINKLES  
and KINKS  
YOU OUGHT  
TO KNOW

**SEND 10c**  
COIN OR STAMPS  
FOR EITHER BOOK  
OR 30c COIN FOR  
THE THREE BOOKS  
**408 PAGES**

They are better than most books sold at \$2 to \$3 a copy. Your money back if you ain't more than pleased.

Address

**BUZZACOTT**  
The Complete Camp  
Outfitters Dept. A  
RACINE JCT., WIS.  
or CHICAGO, ILL.

Don't be like the man riding backwards on a street car, never sees anything until HE'S PAST IT. "SEND FOR ONE NOW."

FIRST EDITION OF 100,000 COPIES NEARLY EXHAUSTED

These Books will soon be issued. Send in your orders now



# Up-to-date Auto designs in Bicycle Cards.

High quality—low price.  
They wear well.  
For sale by dealers.

The U. S. Playing Card Co.

Cincinnati, U. S. A.

Hoyle for 10c. In stamps—128 pages.  
Address Dept. 23.

For Duplicate Whist, best of card games, use Paine's Trays. Lessons free with each set of trays. Write for particulars.

I used and sold Peters shells 2 years and consider them inferior to Winchester and U. M. C. In rifles I have shot everything from a 22 to a 45-70. A Winchester is my favorite. Have owned 2 Marlins, a 32-20 and a 32-40, and have no further use for that make. I use a Remington shot gun and find it satisfactory. For ducks and foxes I load with 26 grains of Infallible. Should like to learn through RECREATION what sportsmen think of the Remington gun.

F. L. Atwell, Durham, Conn.

It is dead easy to secure subscriptions for RECREATION.

J. T. Edwards, Richmond, Va.

The best storage place for roll film negatives is in a printing frame with the back springs taut. When required for printing, they will come out flat. This is infinitely better than smearing the gelatine side with glycerine, which is likely to induce the growth of fungus.—Exchange.

I would not miss a single copy of RECREATION under any circumstances. I think it the best edited sportsman's journal in existence. I have taken them all, at one time or another, but none of them come up to RECREATION.

A publication of the character and merit of RECREATION ought to be encouraged.

David J. White, Pawtucket, R. I.

## MAGNIFICENT XMAS GIFT

Get a sensible present. This table will last a lifetime and entertain every member of the family at the popular games of billiards and pool. In the dining room it will serve them three times a day. Dining table size  $\frac{7}{8}$  standard,  $3\frac{1}{2} \times 7$  feet. Elegantly and artistically designed. Attractively finished. Five massive beautifully hand-carved legs. Our most popular pattern. Write for illustrated catalog. It's **FREE**.



ROYAL DINER \$135

### Indianapolis Combination Table LIBRARY - DINING - BILLIARD - POOL

High grade, stylish, unexcelled playing qualities. Instantly changed from Billiard to Pool by use of successful patent carom plugs and to Dining and Library Table by replacing top. Quarter sawed oak, fleish or golden finish. Highly polished. Complete Billiard and Pool outfit of regulation quality, including 4 genuine ivory billiard balls, 16 pool balls, 6 cues, triangle, etc. Price \$135.00, freight prepaid. Other styles Combination Billiard or Pool Tables, \$25 to \$450.00. Sold on monthly installment plan if desired.

Combination Billiard and Pool Table. Freight paid. Four section dining table top, may use but three sections. Best Vermont Slate Bed. Patent Invisible Pockets. Wonderfully Sensitive Solid Rubber Cushions. Imported French Billiard Cloth. Best Workmanship throughout.

COMBINATION BILLIARD MFG. CO., 33-43 Ingalls, Indianapolis, Ind.

The very soul of the malt-  
delicious, healthful, invigor-  
ating, and *absolutely* pure-  
the perfection of brewing-is

# Pabst Blue Ribbon

The Beer of Quality



## SOME RARE OPPORTUNITIES

These goods are all new, and will be shipped direct from factory. Prices named are those at which manufacturers and dealers usually sell. Here is a good chance to get

A Book, a Gun, a Camera  
A Sleeping Bag, a Fishing Rod  
A Reel, a Tent, } FREE OF COST

Subscriptions need not all be sent at once. They may be sent in installments as taken and credit will be given on account. When the required number is obtained the premium earned will be shipped.

### TO ANY PERSON SENDING ME

TWO new yearly subscriptions to RECREATION at \$1 each, I will send a copy of *Hunting in the Great West*, cloth; or a Zar Camera, listed at \$1; or an Ingersoll Watch or Cyclometer, listed at \$1; or a Recreation Waterproof Match Box, made by W. L. Marble and listed at \$1; or a Shakespeare Revolution Bait listed at 75 cents; or a Laughlin Fountain Pen; or a dozen Trout Flies, assorted, listed at \$1; or a pair of Attachable Eyeglass Temples, gold-plated, made by Gall & Lembke; or one Rifle Wick Plug, made by Hemm & Woodward, Sidney, Ohio, 30 caliber to 50 caliber, or Shotgun Wick Plug, 20 gauge up to 10 gauge, or a pair of chrome tanned horsehide hunting and driving gloves, listed at \$1.50, made by J. P. Luther Glove Co.

THREE new subscriptions at \$1 each, a safety pocket ax, made by W. L. Marble and listed at \$2.50; or a dozen Bass Flies, assorted, listed at \$2; or a pair of Shotgun Wick Plugs made by Hemm & Woodward, Sidney, Ohio, 20 gauge to 10 gauge; or a Polished Buffalo Horn Gun Rack, made by E. W. Stiles; or a pair of gauntlets, for hunting and driving, ladies' size, listed at \$2.50, made by J. P. Luther Glove Co., or a Press Button Jack Knife, made by The Novelty Knife Co., and listed at \$1.

FOUR new subscriptions at \$1 each, an Ideal Hunting Knife, made by W. L. Marble and listed at \$2.50; or a 32 caliber, automatic double action revolver, made by Harrington & Richardson Arms Co.

FIVE new subscriptions at \$1 each, a copy of *Cruisings in the Cascades*, cloth; or a set of Nehring's Convertible Ampliscopes, listed at \$5.00; or an Ideal Hunting Knife made by W. L. Marble, and listed at \$3; or a pair of lock lever skates, made by Barney & Bery, listed at \$4.50; or a J C Hand trap made by the Mitch 11 Mfg. Co., listed at \$4; or a Bristol Steel Fishing Rod, listed at \$6. or less; or a Yawman & Erbe Automatic Reel, listed at \$6 to \$9.

SIX new subscriptions at \$1 each, a Hawkeye Refrigerating Basket made by the Burlington Basket Co., or one dozen Eureka golf balls listed at \$4; or a Pocket Poco B 3¼ x 4¼. made by the Rochester Optical & Camera Co., listed at \$9; or a pair of horsehide hunting boots, listed at \$10.

SEVEN new subscriptions at \$1 each, a copy of *The Big Game of North America*, or of *The American Book of the Dog*, cloth, or one set Lakewood golf clubs, 5 in number, listing at \$5; or a series IIB or IID Korona Camera, made by the Gundlach Optical Co., listed at \$10.

EIGHT new subscriptions at \$1 each. A series 1, 4x5, Korona Camera, made by the Gundlach Optical Co., listed at \$12. or an Acme single shot gun, made by the Davenport Arms Co., and listed at \$8.

TEN new subscriptions at \$1 each, a Cut-Glass Salad Bowl, made by Higgins & Seiter, and listed at \$4.50; or a Waterproof Wall Tent 7 x 7, made by Abercrombie & Fitch, and listed at \$8; or a Rough Rider rifle telescope, made by The Malcolm Rifle Sight Mfg. Co., and listed at \$12; or a Pneumatic Camp Mattress, listed at \$18.

TWELVE new subscriptions at \$1 each, a Peabody Carbine valued at \$12; or a Davenport Ejector Gun, listed at \$10., or a Cycle Poco No. 3, 4x5, made by the Rochester Optical & Camera Co., listed at \$15; or an 8 ft folding canvas boat, made by the Life Saving Canvas Boat Co., listed at \$29.

FIFTEEN new subscriptions, \$1 each, a Shakespeare Reel, Silver Plated, listed at \$15; or a set of rabbit plates made by Higgins & Seiter, and listed at \$8, or a Field Glass made by Gall & Lembke; or a Kenwood Sleeping Bag, complete, with canvas cover, listed at \$16; or a Bulls-Eye rifle telescope, made by The Malcolm Rifle Sight Mfg. Co., and listed at \$16; or a 10 ft. special canvas boat, made by the Life Saving Canvas Boat Co., and listed at \$35.

TWENTY new subscriptions at \$1 each, a 14-karat small size Gold Hunting-case Watch, with Waltham Movement, listed at \$20; or an Elita single shot gun, made by the Davenport Arms Co., and listed at \$18., or an Acme Folding Canvas Boat, No. 1, Grade, A listed at \$27; or a Mullins Buck Boat, listed at \$20.

TWENTY-FIVE new subscriptions at \$1 each, A 4 x 5 Planatic lens, made by the Rochester Lens Co., and listed at \$45.

THIRTY new subscriptions at \$1 each, a Waterproof Tent, 14½ x 17, made by Abercrombie & Fitch, and listed at \$25.

FORTY new subscriptions at \$1 each, a Savage .303 Repeating Rifle; or a No. 10 Gun Cabinet, made by the West End Furniture Co., and listed at \$32.

FIFTY new subscriptions at \$1 each, a No. 20 Gun Cabinet, made by the West End Furniture Co., and listed at \$38.

TWO HUNDRED new subscriptions at \$1 each, a strictly first class upright piano, listed at \$750.

Address, **Recreation** 23 West 24th St.  
New York



**Jaeger**  
 PURE WOOL UNDERWEAR

Science devised it  
 Experience perfected it  
 Prudence prescribes it  
 Health requires it

**MAXIMUM OF WARMTH  
 with MINIMUM OF WEIGHT**

“Chill December” has no terrors for  
 the wearer of a Jaeger undersuit.

**All Weights for all Wants.**

*Catalogue and Samples Free.*

**Dr. Jaeger S. W. S. Co.'s Own Stores**

NEW YORK: 306 Fifth Ave., 157 B'way.

BROOKLYN: 504 Fulton Street.

BOSTON: 230-232 Boylston Street.

PHILADELPHIA: 1510 Chestnut Street.

CHICAGO: 82 State Street.

**AGENTS IN ALL PRINCIPAL CITIES.**

**PRESIDENT  
 SUSPENDERS**



**In Beautiful Boxes For  
 CHRISTMAS**  
 All stores 50c and \$1.00  
 or mail prepaid

The C. A. Edgarton Mfg. Co., Box 219, Shirley, Mass.

**FELL TO A 30-40.**

Game is scarce in this part of Colorado; elk and antelope gone, and few deer remain.

In the fall of 1901, Harry Freeman and I were on a prospecting trip. Early one morning we set out for the hills. On the way we came across the bodies of 7 horses, evidently victims of a mountain lion. A little further on we came to a gulch, just at timber line, full of bunch grass and mountain pinon. Presently we saw 4 bucks feeding, close together about 600 yards away. Harry wanted to try a crack at them with his 38-40 Win-

chester, but I persuaded him not to risk it, knowing the smoke would betray our position in case he missed. I got a perfect sight against the largest buck with my 30-40 and fired. For a moment the deer stood motionless. “You never touched him,” Harry said. Just then the buck toppled over, and away went his companions. The buck was a fine big fellow, and it cost us 2 tiresome trips to get the meat to camp.

The 30-40 is the game gun for this country.

Andy Starr, Silver Cliff, Col.

No. 58

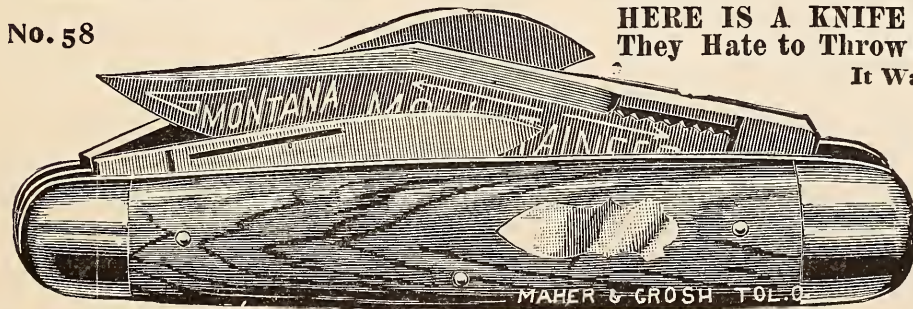

**HERE IS A KNIFE Men Love So Much  
 They Hate to Throw an Old Handle Away  
 It Was Teddy's Camp Knife!**

No. 58. Cut is exact size; ebony handle, 3 blades, German Silver ends. The long blade is for rough or fine work; the medium blade is as thin as a razor. Price, postpaid, \$1.60 for \$5.

The lower cut is “Chauncey Depew's pet,” has three blades (one is a file). Handle is choicest selected pearl; German silver back and ends. Price in chamois case, \$1.50 postpaid. Same knife, 2 blade, \$1; plainer finish, 3 blade, same quality, \$1; smaller 2 blade, for lady, 75 cents.

Illustrated 80-page List free, and “How to Use a Razor.”

**Maher & Grosh Co.**  
 74 A STREET, TOLEDO, O.



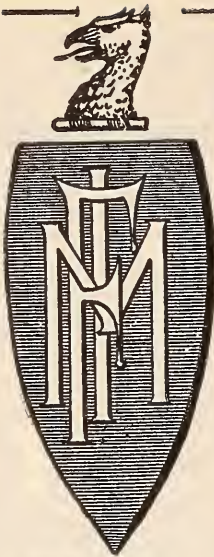

# MATTHEW I. FOX

1123 BROADWAY

Madison Square and 25th Street

## TAILOR AND IMPORTER

I refer by permission to the editor of RECREATION

**\$100** will be paid for the best design of the **DENSMORE**  
As the **OFFICIAL TYPEWRITER** of the  
**ST. LOUIS WORLD'S FAIR**

Design to be used for half page advertisement in magazines, etc. Award for this design to be made February 1, 1904.

Fac-simile letter from World's Fair, adopting the DENSMORE, together with catalogue, etc., sent on request. Mention RECREATION.

**DENSMORE TYPEWRITER CO., 309 Broadway, N. Y.**

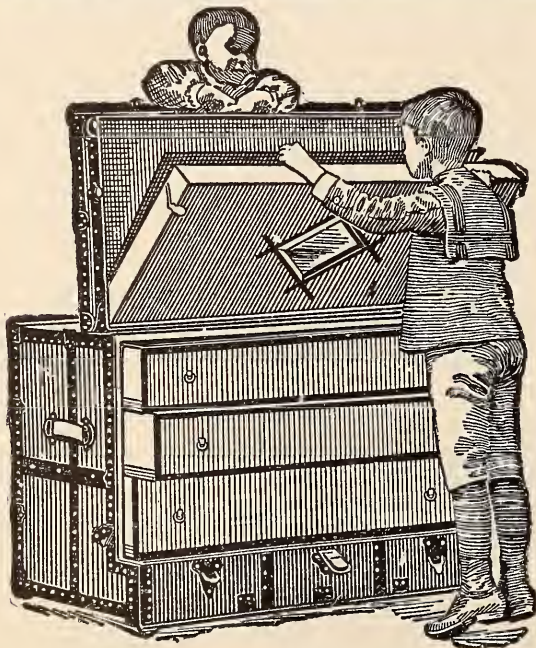

**Stallman's Dresser Trunk** Have you seen one? It is up-to-date. Think of it, everything within reach. No heavy trays, but light, smooth drawers. Holds as much and costs no more than a good box trunk. Hand riveted, almost indestructible. Once tried, always recommended. Sent C. O. D., privilege examination. ec. stamp for catalogue. Mention RECREATION.

**F. A. STALLMAN,**

87 W. Spring St.,

Columbus, O.

**Free:** If you send your subscription to RECREATION through me or direct to the office to be placed to my credit, I will send you, free of charge, any one of the articles mentioned below:

Shot gun bench crimper, sells for 75 cents, in 10-12 16-20 gauge.

Shot gun cleaning rod, three attachments, sells for 50 cents, in 10-12 16 gauge.

Micrometer powder and shot measure, adjustable, and for both black and smokeless powder, sells for 65 cents.

U. S. Government rifle cleaner, any caliber, with attachments, sells for 60 cents, packed in neat canvas bag.

A duck, snipe or turkey call, sells for 75 cents each, best made.

A hand painted sporting picture, suitable for framing, and just the thing for your den, worth \$1.50.

"Hunting in the Great West," by G. O. Shields. H. S. Hill, 815 11th Street, N. E., Washington, D. C.

### FREE BOOK, WEAK MEN



My illustrated nature book on losses varicoce e. impotency, lame back, free sealed, by mail. Much valuable advice and describes the new DR SANDEN HERCULEX ELECTRIC BELT. Worn nights. No drugs. Currents soothing. Used by women also for rheumatic pains, etc 5,000 cures 1902 Established 30 years. Advice free.

**DR. G. B. SANDEN,**

1155 Broadway, N Y.

# THE Keeley Cure

**Alcohol,  
Opium,  
Tobacco  
Using \***

Produce each a disease having definite pathology. The disease yields easily to the Treatment as administered at the following Keeley Institutes:

**ALWAYS ADDRESS THE INSTITUTE NEAREST TO YOU.**

- |                      |                       |                     |                    |
|----------------------|-----------------------|---------------------|--------------------|
| Birmingham, Ala.     | Crab Orchard, Ky.     | White Plains, N. Y. | Providence, R. I.  |
| Hot Springs, Ark.    | New Orleans, La.,     | Omaha, Neb.         | Columbia, S. C.    |
| Los Angeles, Cal.    | 1628-38 Felicity St.  | Cor. Leavenworth    | Dallas, Tex.,      |
| San Francisco, Cal., | Portland, Me.         | and 19th Streets    | Bellevue Place.    |
| 1170 Market St.      | Lexington, Mass.,     | Columbus, O.        | Richmond, Va.      |
| West Haven, Conn.    | Grand Rapids, Mich.   | Cor. 3rd and        | Seattle, Wash.     |
| Washington, D. C.,   | St. Louis, Mo.        | Dennison Aves.      | Huntington, W. Va. |
| 211 N. Capitol St.   | 2803 Locust St.       | Portland, Ore.      | Waukesha, Wis.     |
| Augusta, Ga.         | Boulder, Hot Springs, | Harrisburg, Pa.     | Toronto, Ont.      |
| Dwight, Ill.         | Boulder, Mont.        | Philadelphia, Pa.,  | Winnipeg, Man.     |
| Charlestown, Ind.    | Fargo, N. D.          | 812 N. Broad St.    | London, Eng.       |
| Marion, Ind.         | North Conway, N. H.   | Pittsburgh, Pa.,    | Cape Town, S. A.   |
| Des Moines, Ia.      | Buffalo, N. Y.        | 4246 Fifth Ave.     |                    |



LESLIE E. KEELEY, M.D., L.L.D.

Details of treatment and proofs of its success sent free on application.

I have sent about two hundred of my employees, from butchers to foremen, and all have been permanently cured. I do not think there is any one thing, or any one man, who ever did the good to humanity that you are doing with your cure.

Head of the great Armour Packing Company, Chicago, Ill., (in a personal letter to Dr. Keeley) said:

## P. D. ARMOUR,

Do you want a Good, Reliable,  
Substantial, Well Made

# Single Barrel Shot Gun

If so, send me

**10 YEARLY SUBSCRIPTIONS**

and I will send you such a  
Gun as a premium

It is made by the *DAVENPORT ARMS CO.*, and this means it is made of good material and that only good workmanship is put on it.

This is one of the many remarkable opportunities *RECREATION* is offering to men and boys to fit themselves out completely for shooting and fishing.

Sample Copies for Use in Canvassing  
Furnished on Application.

Address

# RECREATION

23 W. 24th St., New York City

Already many thousands of people are wondering what they are going to get for Christmas presents. Other thousands are wondering what they are going to give their friends. If you wish to make a present to a man or boy who is interested in shooting, fishing, amateur photography, or nature study, give him a year's subscription to *RECREATION*. Nothing you can possibly buy for \$1 would give him so much pleasure as 12 issues of this magazine. Come early and avoid the rush.

Cameras should be tested every 2 months by exposing a plate in the camera with the shutter closed for say half an hour. Then develop the plate, and if it shows no signs of being light struck, your bellows and shutter do not leak light.—Exchange.

**BORATED TALCUM**

# MENNEN'S TOILET POWDER



**A Positive Relief For**  
**PRICKLY HEAT, CHAFING, and SUNBURN,**  
AND ALL AFFLICTIONS OF THE SKIN.

"A little higher in price, perhaps, than worthless substitutes, but a reason for it." Removes all odor of perspiration. Delightful after Shaving. Sold everywhere, or mailed on receipt of 25c. Get Mennen's (the original). Sample Free.

**GERHARD MENNEN CO., Newark, N. J.**



**THE  
ALTON'S  
1904  
COW-BOY  
GIRL**

TRADE-MARK.

"Sequel to the Fencing  
Girl."

Copyright, 1903, by  
Chicago & Alton  
Railway.

**ART CALENDAR**

Four graceful poses from life; figures ten inches high, reproduced in colors by a process far superior to last year's calendar. Highest example of lithographic art.

**"THE ONLY WAY"**

to own one of these beautiful calendars is to send twenty-five cents with name of publication in which you read this advertisement, to GEO. J. CHARLTON, Gen'l Passenger Agent, Chicago & Alton Railway, CHICAGO, ILL.

The best railway line between CHICAGO, ST. LOUIS, KANSAS CITY and PEORIA. Take the "Alton" to the St. Louis World's Fair, 1904.

**THE NEW  
WHITE HOUSE  
CALENDAR**

TRADE MARK



For 1904. Four sheets 9x12 inches. Exterior and interior views, in colors, of the New White House and grounds. Also pictures from life and autographs of the President, Mrs. Roosevelt, Miss Alice Roosevelt and the children. A Christmas present or holiday card useful for a year.

**FIFTY CENTS**      **NO ADVERTISING**

Remit direct, in stamps or cash, to  
**The White House Calendar Company,**  
[Incorporated]  
1040 Fine Arts Building, Chicago, Ill.  
Liberal discounts to agents and canvassers.

# Sent on Approval TO RESPONSIBLE PEOPLE Laughlin

## Fountain Pen

Guaranteed Finest  
Grade 14k.  
**SOLID GOLD PEN.**

To test the merits of

## RECREATION

as an advertising medium  
we make this grand special  
offer, your choice of

These  
Two  
Popular  
Styles  
For Only **\$1.00**  
Postpaid  
to any  
Address

(By Registered mail 8 cents extra)

Holder is made of finest  
quality hard rubber, in four  
simple parts, fitted with  
very highest grade, large  
size 14k, gold pen, any flex-  
ibility desired—in feeding  
device perfect.

Either Style—**RICHLY  
GOLD MOUNTED** for pre-  
sentation purposes, \$1.00  
extra.

## Grand Special Offer

You may try the pen a  
week; if you do not find it  
as represented, fully as  
fine a value as you can  
secure for three times the  
price in any other makes,  
if not satisfactory in every  
respect, return it and we  
will promptly refund your  
money.

Illustration on left is full  
size of Ladies' style; on  
right, Gentlemen's style.  
**Lay this RECREATION Down  
and Write NOW.**

Safety Pocket Pen Hold-  
er sent free of charge with  
each Pen.

ADDRESS ;

**Laughlin Mfg. Co.**  
424 Griswold St., DETROIT, MICH.

# FOR A HOLIDAY PRESENT

What could  
be better  
than a

## Press-Button Knife?

Which a single pressure of the button opens? It locks open, cannot close on the fingers, saves the finger nails, has two blades hand-forged from Wardlow's best English steel, and is in every respect as good a knife as can be made. Ladies' and Gentlemen's sizes in Stag, Shell or Ivory handles, including moisture-proof Chamois case, securely mailed to any address for **75 CENTS**.

Send for Catalogue K for description and prices of other styles.

THE  
NOVELTY  
KNIFE CO.

426 East 52d Street

NEW YORK

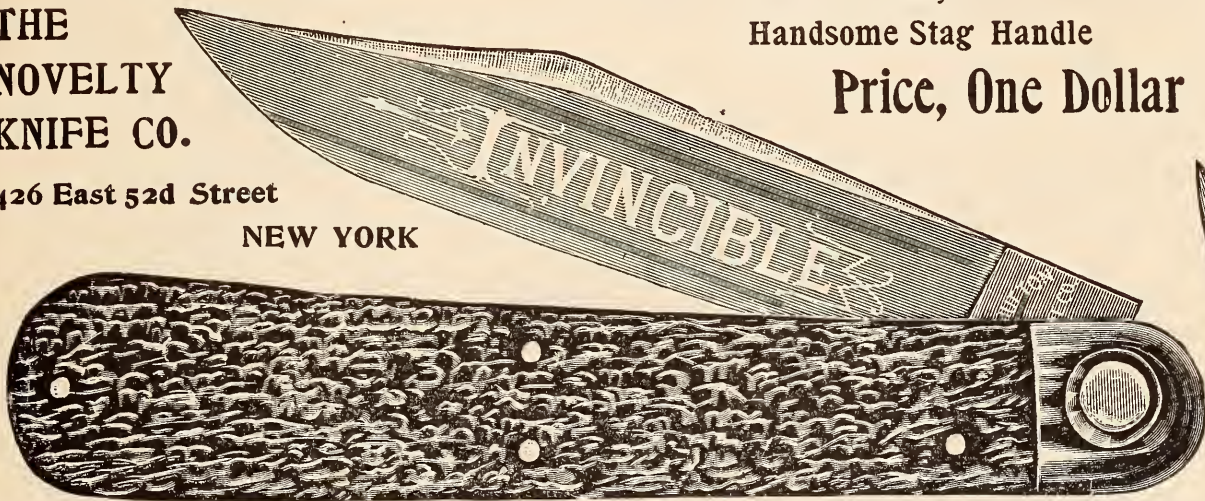

FOR  
Hunting  
Fishing or Camping

Our 5-inch Press Button Jack Knife can not be excelled. Can be opened with one hand, and will not open or close accidentally.

Handsome Stag Handle

Price, One Dollar

I take RECREATION and like it exceedingly. I am a laboring man and do not have much time to hunt, though I enjoy nothing better. I have read some of your books and know that you practice what you preach.

George Blades, Aurora, Neb.

The 2 Davenport guns, one 16 gauge, the other 20, which you gave me as premiums, were in my hands 2 days after you ordered them. I could not wish for better shooting guns.

W. L. Remington, Meriden, Conn.

The RECREATION match box sent me for 2 subscriptions is all right and just what I wanted. Accept thanks.

J. Fr. McKee, Gloversville, N. Y.

English Tourist: Waiter, bring me some sugar, please.

Wild West Waiter: There ain't but 3 lumps in the house, cap. You kin have them as soon as them gents gits through with 'em; they've got 'em marked and they're shaking dice with 'em.—Exchange.

**PLAYS** Dialogues, Charades, Recitations and other entertainment books. Send for free catalog of over 2000 plays.

Dramatic Publishing Company  
358 Dearborn St. Chicago, or 40 W. 28th St., New York

Why does he so dislike ministers?

He can't forget that one of them performed his marriage ceremony.—Exchange.

**PIANO** Do You Want a  
Genuine Bargain

Hundreds of Upright Pianos returned from renting to be disposed of at once. They include Steinways, Knabes, Fischers, Sterlings and other well known makes. Many cannot be distinguished from new yet all are offered at a great discount. Uprights as low as \$100. Also beautiful New Uprights at \$125, \$135, \$150 and \$165. A fine instrument at \$290, fully equal to many \$400 pianos. Monthly payments accepted. Freight only about \$5. Write for list and particulars. You make a great saving. Pianos warranted as represented. Illustrated Piano Book Free.

**LYON & HEALY**

39 Adams St., CHICAGO.

World's largest music house; sells Everything known in Music

**American Typewriters**



\$10  
\$40 \$50

No. 2 is the only practical machine which produces perfect work and which sells for \$10

No. 5 is sterling value for \$40.

No. 7, our latest model, absolutely high grade in every respect.

Sold on installment \$50. Send for illustrated catalogue and easy payment plan.

**AMERICAN TYPEWRITER CO.**  
260½ Broadway, New York

ORDER FROM THE PERIODICAL DEPT. OF THE AMERICAN NEWS COMPANY,

TO Mr. Y. O. Shields  
NEW YORK, Oct 11, 1897

ANSWER BY RETURN ON ALL GOODS YOU CANNOT FURNISH AT ONCE.

SEND GOODS TO THE NEWS COMPANY FOR ENCLOSURE. BILLS AND ANSWER TO US.

Please make order for Recreation - 12500

TO Mr. Y. O. Shields  
NEW YORK, Oct 10, 1897

ANSWER BY RETURN ON ALL GOODS YOU CANNOT FURNISH AT ONCE.

SEND GOODS TO THE NEWS COMPANY FOR ENCLOSURE. BILLS AND ANSWER TO US.

Please make order for Recreation 16000

TO Mr. Y. O. Shields  
NEW YORK, Sept 10, 1900

ANSWER BY RETURN ON ALL GOODS YOU CANNOT FURNISH AT ONCE.

SEND GOODS TO THE NEWS COMPANY FOR ENCLOSURE. BILLS AND ANSWER TO US.

Please make order for Recreation 19600

Any advertiser who may call here will be shown my subscription lists, containing 34,000 names; also my Post Office receipts and printer's bills. An advertiser is entitled to know what he is paying for when buying space, and I am always glad to show him just what he gets when he buys space in RECREATION.

35½

THE AMERICAN NEWS COMPANY,  
39 & 41 Chambers Street.

New York, *Oct 10* 1902

To *Mr G. Shields*

Please make our order for the next issue of

*Recreation* *22500*

*Twenty Two Thousand Five* Copies

and continue same unless otherwise directed. *Amund*  
Respectfully,

THE AMERICAN NEWS COMPANY.

New York, *Oct 10* 1902

PERIODICAL DEPARTMENT

To *Recreation*

Please make our order for the next issue of

*Recreation* *30400*

*Thirty Thousand Four Hundred* Copies

and continue same unless otherwise directed.  
Respectfully,

THE AMERICAN NEWS COMPANY.

per *Deevey*

By noting carefully the dates and amounts in each of the above letters you will see that the American News Company's orders for RECREATION have steadily increased from 12,500 copies in 1897 to 30,400 in 1903. These are standing orders. Then the company buys an average of 2,000 copies each month on supplementary calls.

---

# TO AMATEUR PHOTOGRAPHERS

Here is a Chance  
to Get a

## FINE CAMERA EASILY

A 4x5 Weno Hawk-eye film camera listing at \$8, for 5 yearly subscriptions to RECREATION. A No. 3 folding Weno Hawk-eye film camera, listed at \$15, for 10 yearly subscriptions to RECREATION.

These are both neat, compact, well made and handsomely finished cameras, capable of doing high-class work.

*Sample copies for use in canvassing  
furnished on request.*

Address RECREATION

23 West 24th St.

NEW YORK CITY



# When Bed Time Comes

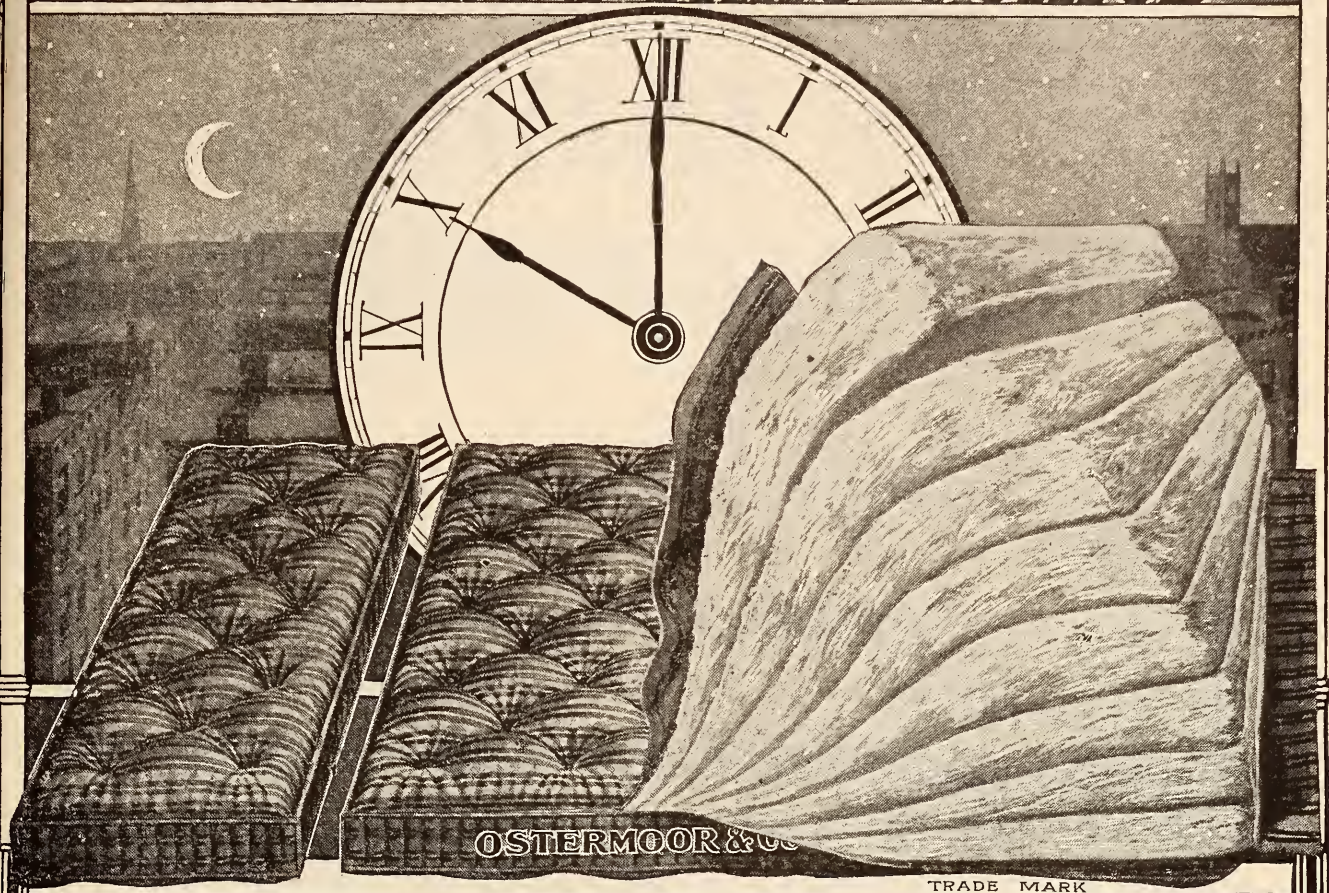

When bed-time comes around, does sleep tempt you or do you lie and toss and fret, vainly seeking that "soft, cool spot" which lulls you to forgetfulness? There is one mattress that gives sleep to the sleepless—rest to the restless—the famous

## Ostermoor Patent Elastic Felt Mattress \$15.

How many people have said "I would give a hundred dollars to be able to sleep," and yet they cling to the lumpy, bumpy, unclean HAIR mattress and fear to invest \$15 in an OSTERMOOR which yields 365 repose-dividends a year, payable every night. These dividends are guaranteed. You can have the experience without any expense by our offer of

### THIRTY NIGHTS' FREE TRIAL

Sleep on it thirty nights and if it is not all you have hoped for, if you don't believe it to be the equal in cleanliness, durability and comfort of any \$50 hair mattress ever made, you can get your money back by return mail—"no questions asked."

#### STANDARD SIZES AND PRICES:

2 feet 6 inches wide, 25 lbs.,	- - -	\$ 8.35
3 feet wide, - 30 lbs.,	- - -	10.00
3 feet 6 inches wide, 35 lbs.,	- - -	11.70
4 feet wide, - 40 lbs.,	- - -	13.35
4 feet 6 inches wide, 45 lbs.,	- - -	15.00

All 6 feet 3 inches long.

In two parts 50c. extra. Special sizes, special prices.

Express charges prepaid to any place.

## Our Book is FREE

It contains 96 pages of text and illustrations of mattresses, pillows, window-seat and cosy-corner cushions, etc., etc.—an encyclopedia of comfort, called "The Test of Time." May we send it? Your name on a postal will do.

**LOOK OUT!** Dealers are trying to sell the "just as good kind." Ask to see the name "Ostermoor" and our trademark label, sewn on the end. Show them you can't and won't be fooled. It's not *Felt* if it's not an *Ostermoor*. Mattresses expressed, prepaid by us, same day check is received.

**OSTERMOOR & CO., 114 Elizabeth Street, New York.**

Canadian Agency: The Alaska Feather and Down Company, Ltd., Montreal.

# ANOTHER GREAT OFFER TO AMATEUR PHOTOGRAPHERS

A 4 X 5 SERIES 1 KORONA CAMERA  
LISTED AT \$12.50, FOR 8 YEARLY SUBSCRIPTIONS TO *RECREATION*;

A 5 X 7 SERIES 1 KORONA CAMERA  
LISTED AT \$18, FOR 12 YEARLY SUBSCRIPTIONS;

A 4 X 5 SERIES 2 KORONA CAMERA  
LISTED AT \$18.50, FOR 14 YEARLY SUBSCRIPTIONS;

A 4 X 5 SERIES 3 KORONA CAMERA  
LISTED AT \$21, FOR 18 YEARLY SUBSCRIPTIONS;

A 4 X 5 SERIES 4 KORONA CAMERA  
LISTED AT \$25, FOR 20 YEARLY SUBSCRIPTIONS;

A 4 X 5 SERIES 5 KORONA CAMERA  
LISTED AT \$36, FOR 30 YEARLY SUBSCRIPTIONS.

*SAMPLE COPIES, FOR USE IN CANVASSING,  
FURNISHED FREE*

A D D R E S S

## R E C R E A T I O N

23 WEST 24<sup>TH</sup> STREET, NEW YORK CITY

# FAY & BOWEN

## Motors and Launches

Operated by Gasoline Vapor

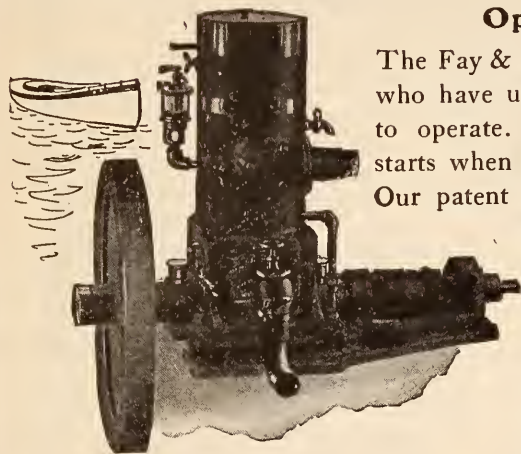

The Fay & Bowen Marine Motor is a revelation to those who have used others. Reliable, safe, durable and easy to operate. Remarkable speed control. Best of all, it starts when you start it. No handle or crank is used. Our patent igniter is absolutely unique and always instant and positive in action. It is really the only perfect and satisfactory igniter.

Motors complete from 1½ to 25 actual Horse Power ready for installation.

We also build a line of the finest launches afloat, complete and with our motor installed and all ready to run.

We make these in either the usual round stern model or our flat stern torpedo model in lengths from 18 to 35 feet. We can furnish large cabin launches on special order. For excellence of workmanship and beauty of finish and design our boats are unsurpassed. Ask for description of our fast torpedo outfits.

*Send for Catalogue and live testimonials from satisfied customers. Our customers are our best advertisers.*

**Fay & Bowen, 28 Mill St., Auburn, N.Y.**



ACME FOLDING BOAT CO., MIAMISBURG, O.

U. S. Government who prefer our boats. Received medal and award at Chicago World's Fair. If you investigate we will get your order. Mention RECREATION.

**Acme Folding Boat Company, Miamisburg, O.**

Mrs. Noddy: Did you notice how the sermon affected old Mister Grimes? He actually shed tears and showed great emotion.

Mr. Noddy: Yes, poor fellow. He put a \$2.50 gold piece in the collection basket, thinking it was a penny.—Express Gazette.

IN ANSWERING ADS PLEASE MENTION RECREATION.

## BIG MONEY In Mail-Order Business

People are buying more by mail than ever before: one mail order house does a business of a million dollars monthly; another receives 2,000 letters daily, nearly all containing money; mail order trading is unquestionably the business method of the future. The field is large, the possibilities unlimited. Let us send you our plan for starting beginners; it covers every point. Enclose stamp.

**CENTRAL SUPPLY CO., Kansas City, Mo.**

## "SMALLEY"

### MARINE GASOLINE MOTORS

are designed for use in any kind of a boat requiring from 1½ H. P. to 20 H. P. Either single or double cylinder. Simple, mechanical, handsome, durable, positive, economical and moderate priced. Our speed control, propeller equipment and many other features should be investigated.

Send for illustrated catalogue. Address Dept. C.

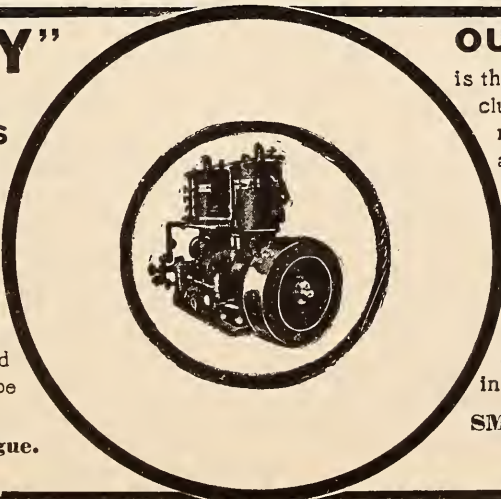

### OUR NEW PLANT

is the largest in the world devoted exclusively to the manufacture of marine gasoline engines. We operate our own pattern, foundry, forge and machine departments. We manufacture every part of our engines from fly wheel to propeller.

Every engine is connected to its propeller and given an actual water test before placed in purchaser's hands.

**SMALLEY MOTOR CO., Ltd.,**

Bay City, Mich., U. S. A.

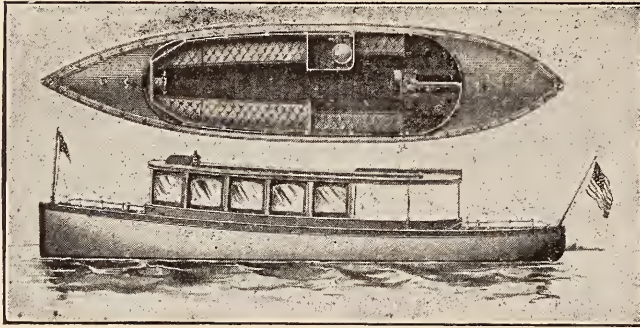

The Highest Grade of Perfection in Hull Construction is found in the

## Matthews' Torpedo Launch

A Stylish, Racy Craft in which we will install any power or motor desired.

Write for our Free Book of Marine Laws and Tables

Mention RECREATION.

**THE MATTHEWS BOAT CO.**

Bascom, Ohio

SALES AGENTS

S. H. Stern, 1414 Michigan Ave., Chicago.  
L. C. Steers, 1470 Jefferson Ave., Detroit, Mich.  
Felix Fournier & Knopf, 103 Rue La Fayette, Paris France.

## A SPORTSMAN'S BOAT Mullins' "Get There" Steel Duck Boat

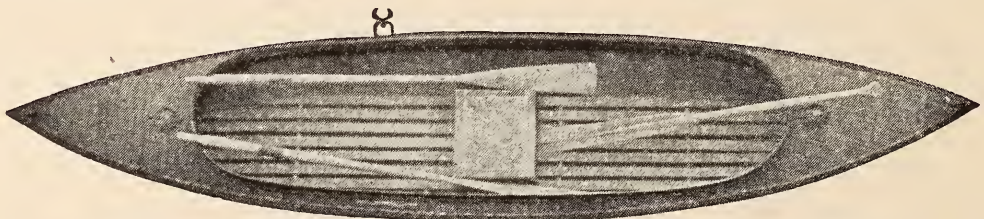

14 ft. long, 36-inch beam.

**PRICE. \$20**

Crated on cars Salem.

Endorsed by Thousands of Sportsmen. Air Chamber each end. Always ready. No repairs  
Send for handsome free book. Mention RECREATION.

**W. H. MULLINS, 228 Depot Street, Salem, Ohio**



## Banner Rubber Coat

No. 28

"Just what I want, and the only coat I ever found that would really shed rain."—

F. A. Knights, M. D.

Absolutely waterproof. Weight 4¾ lbs. Sent express paid U. S. on receipt of \$5. Sizes 36 to 46 inches (breast). Length 52 inches.

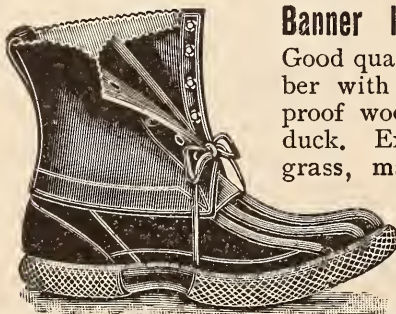

## Banner Hunting Shoes

Good quality ribbed rubber with top of waterproof wool lined brown duck. Excellent for wet grass, marsh or snow.

10 in. high. Sent express paid in U. S. on receipt of \$3.50.

**Northern Rubber Co. Box P 336 St. Paul, Minn.**

**Burnt Work—Something Great.** To persons sending subscriptions to RECREATION through me, or sending them direct to the office to my credit, I will send the following prizes:

For 1 yearly subscription to RECREATION I will give a neat barrel match safe mounted on an oval back, both burned and decorated, equal in value to 75 cents.

For 2 yearly subscriptions to RECREATION I will give a 6 inch round picture frame burned and decorated with beautiful old fashioned poppies tinted with water colors. These would cost you \$1.25 at the least.

For 5 yearly subscriptions to RECREATION I will give either a round stool 14 inches high with round upholstered top or a square stool same height with square upholstered top. These would probably cost you \$7 or \$8 finished as I finish them with designs burned in the wood and leather.

E. A. King, Pleasant Prairie, Wis.

**Something Special—Playing Cards Free:—**To each person sending me \$1 for one year's subscription to RECREATION, or sending it direct to be placed to my credit, I will forward, all charges prepaid, a pack of elegant gold edge playing cards. These are no cheap second quality cards but first quality, of extra selected stock, highly enameled and polished, fancy set pattern backs, each pack wrapped in handsome glazed wrapper and packed in strong telescope case.

L. J. Tooley,

141 Burr Oak St., Kalamazoo, Mich.

# He is Pleased to be Caught

by a

## "Bristol" Steel Rod.

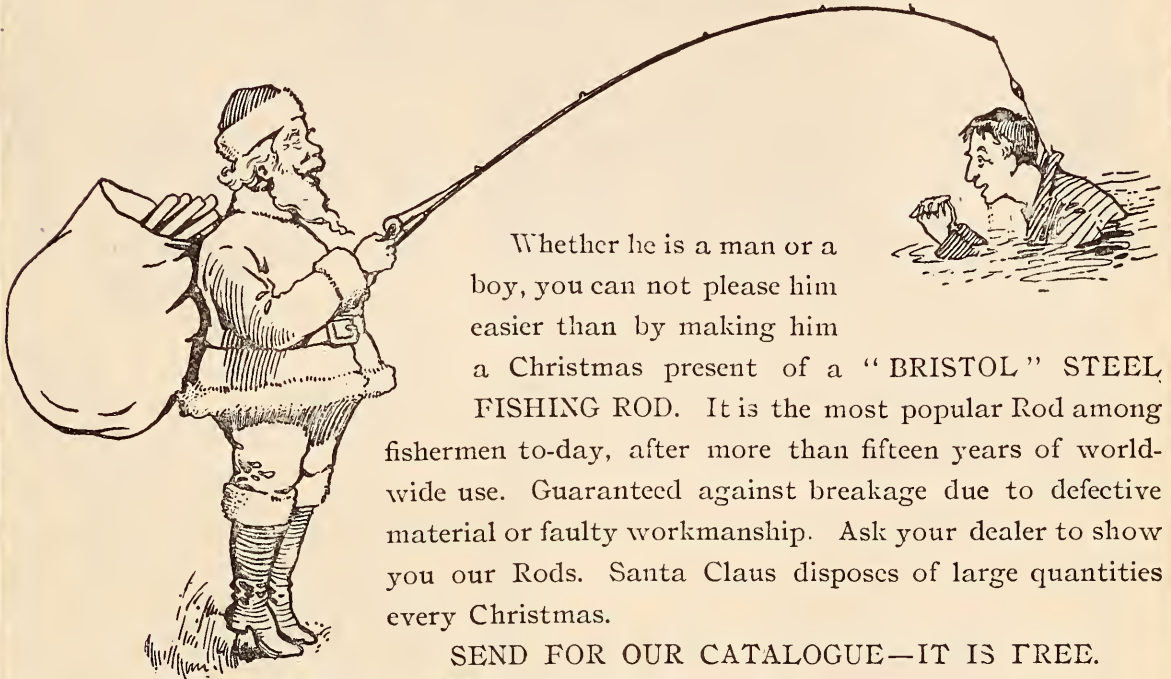

Whether he is a man or a boy, you can not please him easier than by making him a Christmas present of a "BRISTOL" STEEL FISHING ROD. It is the most popular Rod among fishermen to-day, after more than fifteen years of world-wide use. Guaranteed against breakage due to defective material or faulty workmanship. Ask your dealer to show you our Rods. Santa Claus disposes of large quantities every Christmas.

SEND FOR OUR CATALOGUE—IT IS FREE.

**The Horton Manufacturing Company,**  
**No. 73 Horton Street, Bristol, Conn., U. S. A.**

# KEEP YOUR HANDS WARM

Send me 2 yearly subscriptions to **Recreation** and I will send you a pair of **Leather Hunting Gloves** made to your measure, by the **Luther Glove Co., Berlin, Wis.**

*Sample copies for use in canvassing furnished on request*



**11-foot Special**

**Folding Canvas Boats** were not satisfactory until the **King** was produced. **It's a revelation** in boat construction. Nothing like it ever made. **Nonsinkable. Can't turn over. Puncture-proof.** Wear longer than a wooden boat. **No repairs.** No cost for storage. **Always ready.** Folds into a small, neat package,—**carry by hand.** Used by the U. S. Navy. They are simply wonderful. A thoroughly patented article. Beware of imitation. Made only by ourselves.

A catalogue of 70 engravings and 350 testimonials sent on receipt of 6 cents.  
 Mention **RECREATION.**

**King Folding Canvas Boat Co.**  
**Kalamazoo, Mich. U. S. A.**

# Going Fishing?

Well fixed for rods? If not,  
send me 5 yearly subscriptions to

**RECREATION**

and get a Bristol Steel Rod—  
any one listing at \$6.00 or less.

---

---

Everybody knows what a Bristol  
Steel Rod is. It is equal in  
strength, durability, suppleness,  
and all the other good qualities to a  
split bamboo rod costing \$20.

This is a great opportunity  
and holds good only **SIXTY**  
days.

Sample Copies of Recreation  
for use in canvassing fur-  
nished on application.

# TRICKS OF MAGIC

Get Your Boy  
THE BANNER  
MAGIC TRICK  
CABINET



with which to give  
**Sleight-of-Hand Performances**

Cabinet of seven clever tricks, with instructions for performing twenty-five illusions. Also an amusing

## Pair of Game Cocks

which appear to fight like real live roosters, and the secret only known to the operator. And a

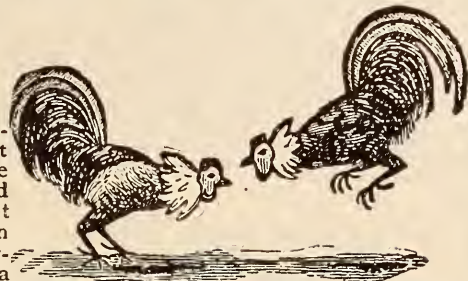

**Swiss Warbler Bird Call, A Rubber Type Printing Outfit, and a mirth-provoking Dancing Skeleton.**

All of these articles sent by mail on receipt of \$1.00.

Order early for Christmas.

**NORTHERN RUBBER CO.**

Box P 336.

**St. Paul, Minn.**

## "Pigeons and All About Them"

F. M. GILBERT'S latest work. 264 pages, illustrated—strictly up-to-date. The only complete Pigeon Book published in the last twenty years. Cuts of all the best-known varieties. Standards of all varieties. Tells how to build loft, buy, mate, breed, feed, how to ship to customers, how to prepare for shows and ship to shows, how to prevent and cure disease, tells which are the best breeders and feeders, tells best varieties to breed in a city and which in small towns, tells how to mate for color—in fact, it tells just what it has taken the author forty-five years to learn by actual experience. Endorsed by all the leading fanciers in America. Hundreds of letters praise it. Fourth edition now out. To get it promptly send one dollar to **Frank M. Gilbert, Evansville, Ind.**

## Taxidermists' Glass Eyes for Stuffed Birds and Animals

Oologists' and Entomologists' Supplies

## Materials

Send 5c. in stamps for catalogue

**FRED. KAEMPFER, 88 STATE ST., Chicago, Ill.**

Taxidermy work done in all its branches

Mention RECREATION

**Squirrels:** They are my specialty. Fox squirrels, \$4 a pair; Flying squirrels, \$2 a pair. A few Black's occasionally at \$7.50 a pair or \$4 each. City parks supplied. Reference G. O. Shields.

E. F. Pope, Colmesneil, Tex.

**For Sale:** Bargains in modern and antique firearms from my collection. They are duplicates and other unnecessary pieces in fine condition. Send stamps for price list. C. W. Sawyer, 41 Humphreys St., Boston, Mass.

**FINE MOUNTED GAME HEADS, BIRDS, ETC.,** for sale at unheard-of prices. Send in cents for photos.  
**JOHN CLAYTON, Taxidermist, Lincoln, Maine**

# CHAMPION



# DOG BISCUIT

ST. PAUL BREAD CO.

Gentlemen:—I would like to have you ship us at once 400 lbs. of Champion Dog Biscuits to feed our show. Bill them to Carl Haggenjos, care of Dog Show Dept., Galesburg, Driving Park Association.

I am, Yours truly,

Carl Haggenjos, Galesburg, Ill.

Write for Samples and Prices to

**ST. PAUL BREAD COMPANY**

Mention RECREATION

St. Paul, Minn.

## Squab Book Free



Squabs are raised in 1 month, bring big prices. Eager market. Astonishing profits. Easy for women and invalids. Use your spare time profitably. Small space and capital. Here is something worth looking into. Facts given in our FREE BOOK, "How to make money with Squabs." **PLYMOUTH ROCK SQUAB CO., 11 Friend St., Boston, Mass.**



## B. Bernard

Buyer of Raw Furs and Ginseng Root.

150 Bleeker St., New York.

Quotations sent on request.

## SPORTSMEN

Learn to Mount Birds, Animals, Heads, Antlers, Tan Furs, Etc.



We teach the art of TAXIDERMISTRY perfectly by mail. The game season is open and you will secure some fine trophies. They deserve a place in your home or office. Why not

### BE YOUR OWN TAXIDERMIST?

We teach the art easily and quickly to any one by *Standard Methods*. Expert instructors; reasonable prices. Endorsed by all leading sporting journals, and recommended

by the most eminent taxidermists. Our interesting catalog tells all about it, and it's yours for the asking.

Write for one to-day.

**The Northwestern School of Taxidermy, Inc.**  
411 A BEE BUILDING OMAHA, NEB.

# A Press Button Hunting Knife

Is one of the best articles a hunter ever carried

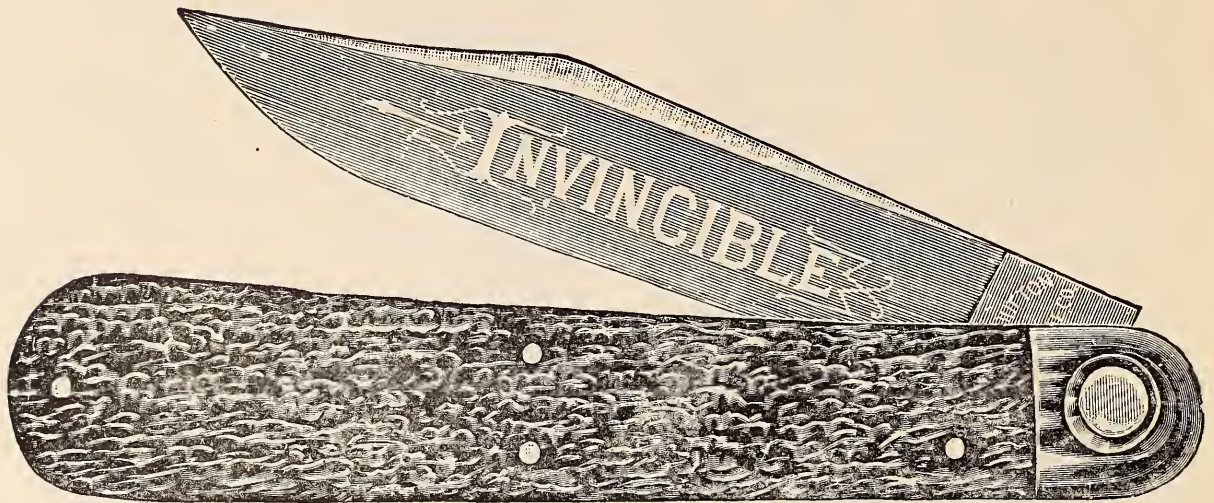

**It has a 4 Inch Blade made of the Best Silver Steel**

The knife cannot come open in your pocket. It cannot close on your hand when in use. It opens and closes only when

**YOU PRESS THE BUTTON**

If you once use one of these knives you will never use any other. You can get one as a premium for

**3 YEARLY SUBSCRIPTIONS TO RECREATION.**

Sample Copies furnished on request.

## PATENTS

promptly obtained **OR NO FEE.** Trade-Marks, Caveats, Copyrights and Labels registered. **TWENTY YEARS' PRACTICE.** Highest references. Send model, sketch or photo, for free report on patentability. All business confidential. **HAND-BOOK FREE.** Explains everything. Tells How to Obtain and Sell Patents, What Inventions Will Pay, How to Get a Partner, explains best mechanical movements, and contains 300 other subjects of importance to inventors. *Address,*

**H. B. WILLSON & CO.** Patent Attorneys  
786 F Street, N. W., WASHINGTON, D. C.

**Free:**—I will give anybody sending me 1 subscription or renewal, any one of the articles named below:

Ideal Shell Closer, 10-12-16 gauge, sells for 50c.

Ideal Shell Loader, 10-12-16 gauge, sells for 50c.

Perfection Gun Oiler, can not spill when not in use, worth 50c.

Web Shot Shell Belt, 10-12-16 gauge, sells for 75c.

Henry B. Floyd, 723 Eighth St., N. W. Washington, D. C.

IN ANSWERING ADS PLEASE MENTION RECREATION.

## RELICS OF A DISAPPEARING RACE

# Buffalo Skulls

WITH POLISHED OR UNPOLISHED HORNS

Also polished or unpolished horns in pairs or single. Polished horns tipped with incandescent electric lights; polished hunting horns; mirrors hung in polished horns, etc. These are decided novelties and are in great demand for sportsmen's dens, offices, club-rooms, halls, etc. Send for illustrated catalog. Mention RECREATION.

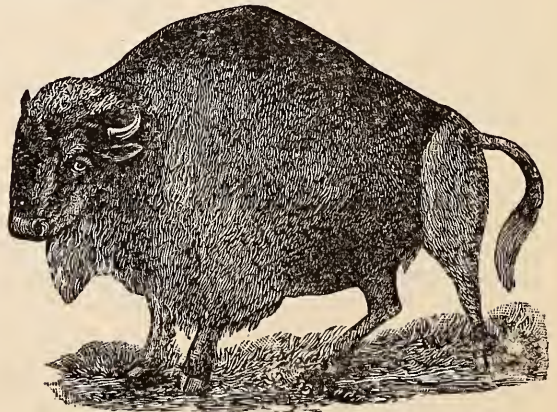

**E. W. STILES**

141 Washington St. Hartford, Conn.



## SOME GOOD GUIDES.

Following are names and addresses of guides who have been recommended to me, by men who have employed them; together with data as to the species of game and fish which these guides undertake to find for sportsmen.

If anyone who may employ one of these guides should find him incompetent or unsatisfactory, I will be grateful if he will report the fact to me.

## ALASKA.

Edwin Edelmann, Kenai, Cook's Inlet, moose, bear, caribou, mountain sheep, ducks, grouse and trout.

## FLORIDA.

Carson Bros., Frostproof, bear, deer, turkeys, quail, snipe.

C. H. Stokes, Mohawk, deer, alligators, turkey, quail, and snipe.

## IDAHO.

John Ching, Kilgore, elk, bear, deer, antelope, mountain sheep, trout and grouse.

Chas. Petty's, Kilgore, ditto.

## MAINE.

H. R. Horton, Flagstaff, deer, bear, moose, caribou, fox, grouse and trout.

W. C. Holt, Hanover, moose, caribou, deer, grouse and trout.

Eugene Hale, Medway, ditto.

## MONTANA.

A. R. Hague, Fridley, elk, deer, mountain sheep, bear, grouse and trout.

Chas. Marble, Chestnut, ditto.

Chas. Jackson, Choteau, ditto.

## NEW YORK.

Le Roy Still, Bayport, Long Island, ducks, quails, rabbits and grouse.

## WASHINGTON.

Munro Wyckoff, Port Townsend, deer, bear and grouse.

## WYOMING.

S. N. Leek, Jackson, elk, bear, deer, mountain sheep, antelope, grouse and trout.

James L. McLaughlin, Valley, elk, bear, deer, mountain sheep, antelope, grouse and trout.

## CANADA.

Wm. S. Andrews, Lillooet, B. C., deer, bear, mountain sheep, goats, grouse and trout.

B. Norrad, Boiestown, N. B., moose, caribou, grouse and trout.

Carl Bersing, Newcastle, N. B., moose, caribou, deer, bear and grouse.

## NEWFOUNDLAND.

John C. LeMoine, Birchy Cove, Bay of Islands, caribou, salmon and trout.

**BIG GAME IN MEXICO.** Bear, Mountain Lion, Jaguar, Deer, Antelope, Mountain Sheep, Wild Hog, Timber Wolf, Wild Turkey. We have a comfortable Hunting Lodge in the heart of the Sierra Madre, in Sonora, Mexico, 2½ days from El Paso, Texas. Our outfit is complete and we furnish everything and make your trip here one that will be pleasantly remembered.

**Rates: \$2.50 a day.** No extra charge for guides. Correspondence solicited. Mention RECREATION.

P.O. Address **CHIHUAHUITA LODGE**  
Colonia Pacheco, Chihuahua, Mexico

# Sportsman's Favorite

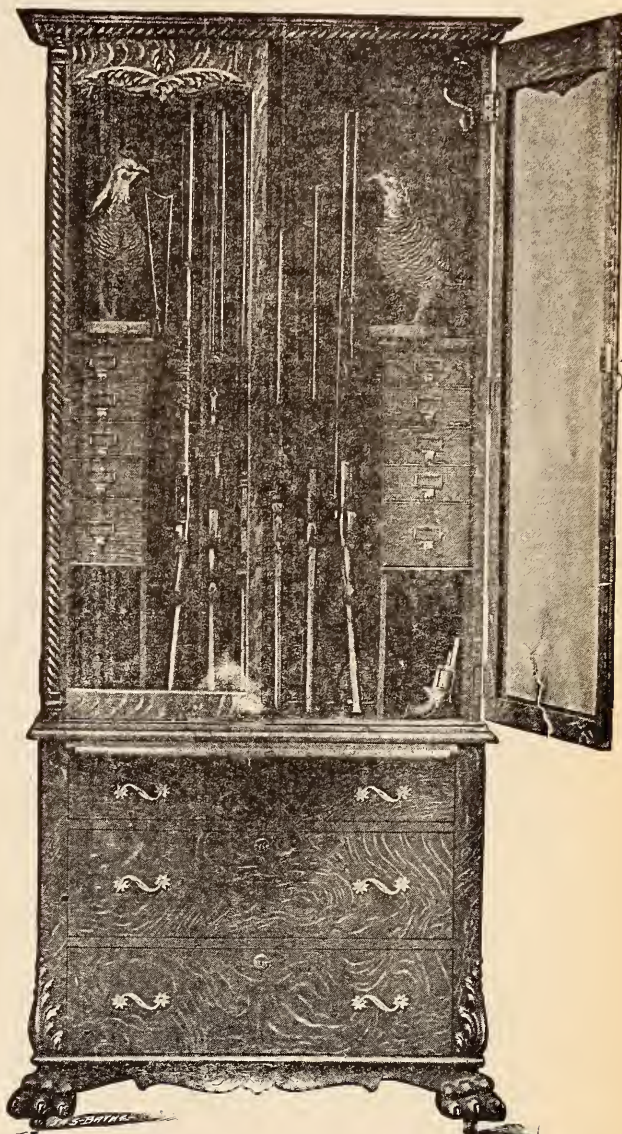

No. 20. Size: 82 inches high, 37 inches wide, 16½ inches deep. Golden Oak or Imitation mahogany, polished.

**Price, \$33.**

## For Convenience

utility and beauty of design, nothing in the sporting goods line appeals more favorably to a sportsman than a cabinet like the above. Here is a right place for everything from the fish hook to the rifle. The up-to-date sportsman wants his outfit compact, orderly and handy. This is impossible without a properly arranged sportsman's cabinet.

We make cabinets from \$17.50 to \$48. Just send stamp for catalog and prices.

Not sold through Dealers.

Mention RECREATION.

## WEST END FURNITURE CO.

Sole Manufacturers  
Williamsport, Pa.

**The Celebrated**  
**THOMPSON-QUIMBY**  
 Hunting Boots, Shoes and Moccasins

**THOMPSON**

I have on file measurements of all who bought Boots and Shoes of the W. Fred Quimby Co., of New York for the past 20 years, and I make the same grade of sportsmen's footwear as they made. I was superintendent of the shoe department of that firm and bought the right to make these boots and shoes. Get a pair now. They will last years and are the cheapest in the end. I refer by permission to the Editor of RECREATION.

Measurement blanks and prices on application. Mention RECREATION.

**T. H. GUTHRIE**  
 33 William Street, NEWARK, N. J.

**PS**

**SON**

*All Work Guaranteed*



## How is your Muscle?

Would you like to build it up?

## How are your Lungs?

Would you like to expand them?

## How is your Circulation?

Would you like to improve that?

If so, send me **6 yearly subscriptions** to RECREATION, accompanied by a money order for \$6, and I will send you a new

## PROFESSIONAL PUNCHING BAG

made by H. D. CRIPPEN, No. 52 Broadway, New York and listed at \$6.95.

There is a frame with the bag that you can attach to a door casing, a window casing or a wall, or a board fence, or anywhere else you may see fit to put it, and you will thus have a small gymnasium of your own. The Crippen bag is one of the liveliest ever devised, and if you will put 20 minutes a day on it, for a month, you will find a wonderful improvement in your muscle and your health.

Sample copies of RECREATION, for use in canvassing, will be mailed free.

## Cedaroleum!

The New Lubricant and Rust Preventive

### A Christmas Present for Your Friend

It is colorless and you can use it anywhere on your gun or rifle. Manufactured of the purest chemicals it meets a demand and need.

It is better than any oil or vaseline.

It is a specific for cleaning rifles and guns after using nitro powders, as well as black. Its peculiar substance makes it the finest lubricant for the mechanism.

It is put up in a neat tube with injector and is handy to carry in your pocket wherever you go.

Send for sample to-day. **Price, 15 Cents.**

Mention RECREATION.

**CEDAROLEUM COMPANY**

Trademark Registered.

Perkinsville, Vt.

**For Sale** :—32-40 Stevens, Ballard action, Salmetzen stock, set triggers, 13 lbs., good condition, \$20; Ideal 25-36-118 gr. loading tool, 50c.; Ideal 25, 73 gr. P mould, 50c.; Winchester, 32; 185 gr. mould, 25c.; 4-joint, 2½ ft. \$9 list telescope, \$2; 38-55 26 in. Marlin bbl., complete for takedown rifle, good as new, \$5; 32-40 bbl. part only for Marlin takedown, \$1; Ideal loading measure, \$1.50; 3 lbs. C.G. semi-smokeless, 75c.; 1 lb. FFFG semi, 20c.; 1 lb. shotgun smokeless, 20c.; 38 S. & W. revolver; mould and loading tool, 50c.; 28-120 Pope lubricating die, 35c. F. S. Merrill, S. 7 Post St.

Spokane, Wash.

### The Reason the LUTHER HAND-MADE GLOVE will not rip



Machine sewing cuts itself



Hand sewing cannot.



## A Practical Hunting and Driving Glove

Made for practical, comfortable, durability. No Oil. No Odor. No Animal Glue. Practically seamless. Cannot Rip. Unaffected by moisture of any kind. If soiled, may be washed with soap and hot water, without injury. The Luther Fastener is adjustable, fits any wrist and cannot get out of order. Illustrated booklet, samples and self measurement rule on application.

If you prefer to buy through your dealer send us his name

No. 308 Driving Glove	postpaid anywhere	\$1.50,	made to measure	\$2
No. 320 Gauntlet,		2.50,	"	3

**J. P. LUTHER GLOVE CO., 536 Pearl St., Berlin, Wis.**

**X  
M A S**

**\$10**

For this  
Gun  
Cabinet  
For  
December  
Only

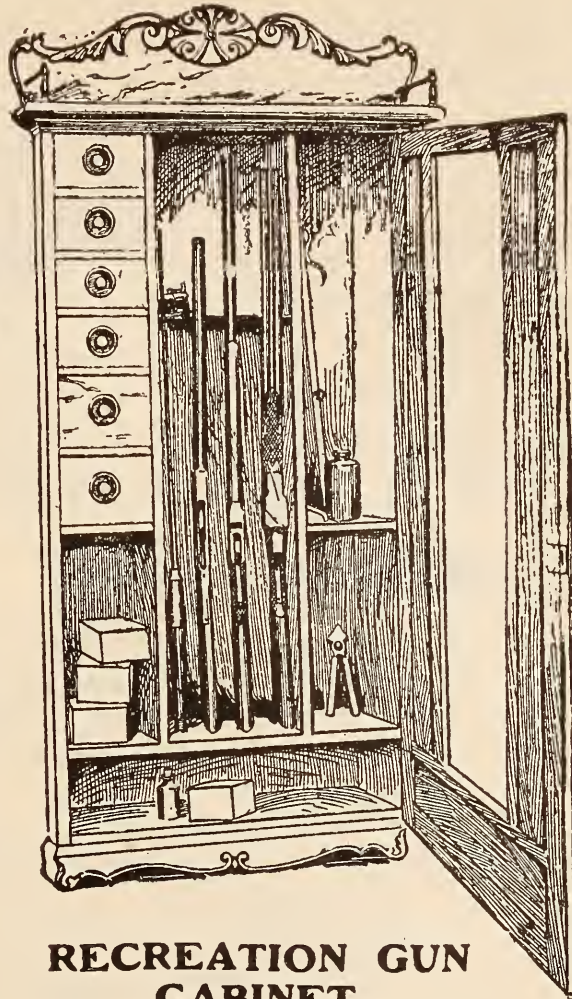

**X  
M A S**

For  
December  
Only  
This Gun  
Cabinet

**\$10**

**RECREATION GUN  
CABINET**

This Cabinet is, without a doubt, the best value ever offered for the price, and the large number of sportsmen who have been wishing for a handsome, well-made Gun Cabinet, at a modern price, will find it their ideal. Made of Oak, Antique finish.

Height, 5 ft. 10 in. Width, 28 in. Depth, 12 in. Padded rack for four guns, and room for fishing rods. Six good, tight drawers for ammunition, etc. Unsightly duffle in the side spaces is hidden from view when door is closed, leaving unobstructed views of Guns.

Crated for Shipment from Factory . . . \$15



**SHOOTING JACKET, \$3**

Guaranteed all wool, seamless, elastic, close fitting, but not binding, comfortable and convenient. Designed especially for duck shooters, trap shooters, etc., but suitable for all outdoor purposes. Must be seen to be appreciated. Made only in two colors—dead grass and Oxford grey.

Send us your address for one of our Gun Catalogs. Mention RECREATION.

**THE H. H. KIFFE CO. - - 523 Broadway, New York**

# HOPKINS & ALLEN POPULAR JUNIOR RIFLES

Rebounding Hammer. Always on Safety when not Cocked. Lever Action Take Down Pattern Barrel Readily Detached from Frame

Shoots  
22 SHORT OR LONG  
RIM FIRE CARTRIDGE

22 in. Barrel. Weight, 4½ lbs. Price, \$5.50

(No. 932—Same as above but 32 Caliber.)  
Shoots 32 Short or Long Cartridge.

Prepaid to any Express Office in U. S. Send for Catalogue No. 70 of Rifles, Shotguns and Revolvers

THE HOPKINS & ALLEN ARMS CO., - Norwich, Conn.



# THE MALCOLM RIFLE TELESCOPE

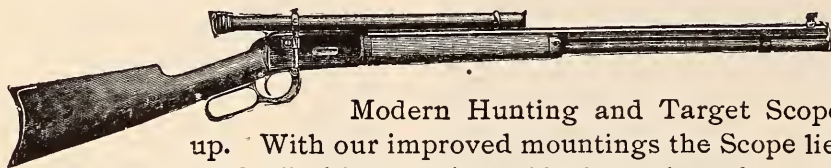

Modern Hunting and Target Scopes from 3-power up. With our improved mountings the Scope lies close to the barrel. Our "Rough Rider" of 3-power is an ideal hunting glass. Our "Bulls Eye" at 5 to 8-power is perfection itself for both hunting and target purposes.

SEND FOR 1903 CATALOGUE

Mention RECREATION.

## THE MALCOLM RIFLE TELESCOPE MFG. CO.

F. T. CORNISH, Mgr.

Established 1857

SYRACUSE, N. Y., U. S. A.

Swedish  
**COLLAN OIL**  
Waterproof  
**LEATHER DRESSING AND RUST PREVENTER**

**"Collan-Oil"**  
preserves leather and renders shoes and harness positively  
**WATERPROOF**  
Used by the U. S. the Army and Navy, and National Guard.  
Send 25c. for trial can.  
**AGENTS WANTED**

Write for terms and circulars  
**J. R. BUCKELEW**  
Dept. A. 111 Chambers St., N. Y.

**Practical Common Sense in 6 Sizes. CAMP STOVE**



Either with or without oven. The lightest, strongest, most compact, practical stove made. Cast combination sheet steel top, smooth outside, heavy lining in fire box and around oven, holds its shape, telescopic pipe carried inside the stove. Burns larger wood and keeps fire longer than any other. Used by over 9,000 campers and only one stove returned.

For catalogue giving full particulars, mention RECREATION and address,  
**D. W. CREE, Manufacturer, Griggsville, Ill.**

**KOENIG'S SHELL EXTRACTOR.**



Every shooter should have one—carry it in a vest pocket. Fits any gauge shell. Koenig's Gun Catalogue, Free.

**10 Cts. Postpaid.**  
**E.G. KOENIG, NEW JERSEY'S LARGEST GUN HOUSE**  
SOUTH BROAD ST., NEWARK, N. J.

**INDIAN CURIOS**



**WHOLESALE & RETAIL CURIO DEALERS' SUPPLY DEPOT.**

Bead Work, Baskets, Elk Teeth, Mexican Goods, Fossils, Minerals, Arrow-Heads, Pottery, Alaska Ivories, Shells, Agates, Photos, Great stock, Big Cata. 5c., stamps. Mention RECREATION. If a dealer, say so.

**L. W. STILWELL**  
DEADWOOD . . . . . SO. DAKOTA



## BRADLEY'S ANTI-RUST ROPES!

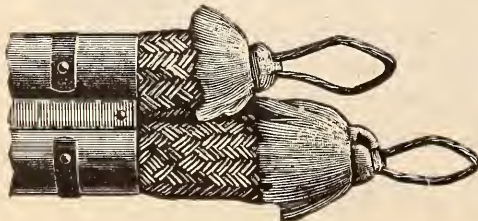

For SHOT GUNS, RIFLES and REVOLVERS. They cannot rust or pit if these ropes are used. No more worrying to keep your fire arms in perfect condition. Sent postpaid, \$1 per set for Shot Guns; 50c. for Rifles; 25c. for Revolvers. Give gauge and length of barrel. Send for circular giving full particulars.

### BRADLEY'S SHOT GUN SIGHT

Makes wing shooting easy and certain. Scores greatly increased at trap and in field. Instantly attachable and detachable. Price, post-paid, 50 cents. Send for circular.

Address **C. L. BRADLEY, CLARKSVILLE, TENNESSEE.**  
Mention RECREATION.



**HAMILTON TAKE DOWN RIFLE** **\$2.00**

Our winter woods are full of sport for the happy owner of a **HAMILTON RIFLE** and intending buyers of Christmas presents should head their lists with a "Hamilton." Every member of the family (except the baby) can enjoy using this ideal weapon and will highly appreciate it as a Christmas gift. It is light and strong, shoots long and short 22-caliber cartridges and has automatic shell ejector. For small game and target practice it is absolutely unrivaled. **Price..... \$2.00**

Our **No. 15 Model**, with a four inch shorter barrel, is practically the same weapon reduced to boy's size. **Price \$1.50.** Ask your dealer to show you Hamilton Rifles. If he cannot, we will deliver either style by prepaid express on receipt of price. Illustrated folder—FREE. **The HAMILTON RIFLE CO., Box 64, PLYMOUTH, MICH.**

## Newhouse Traps

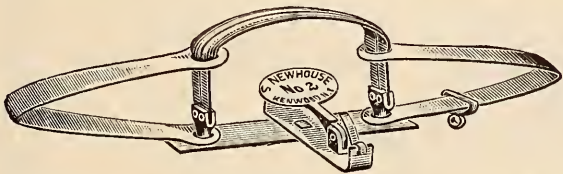

THE STANDARD FOR OVER FIFTY YEARS

Used by all professional hunters and trappers, who find that

**The Best Trap is the Cheapest**

Complete illustrated catalogue on application.

ONEIDA COMMUNITY, LTD, Kenwood, N. Y.

## A KNIT JACKET

A handy and comfortable garment to wear when shooting

**At the trap  
In the field, or  
In the woods.**

For 3 yearly subscriptions to RECREATION I will send you a Hand Knit Jacket, made by Geo. F. Webber, Detroit, Mich., and listed at \$4. You can get the 3 subscriptions in 20 minutes.

Sample copies of RECREATION sent on request.

## DU PONT SMOKELESS

At Michigan State League Shoot Max Heusler won the State Expert Trophy, 24 out of 25, and then 25 straight. W. Carson won State Amateur championship.

## DU PONT SMOKELESS

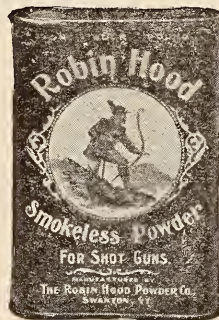

It Still Leads Them All for Light Recoil Great Penetration Even Pattern

**Robin Hood Powder**



**COMET and ROBIN HOOD LOADED SHELLS**

MANUFACTURED BY

**The Robin Hood Powder Co.**  
Swanton, Vt.

Are You an  
Amateur  
Photographer?

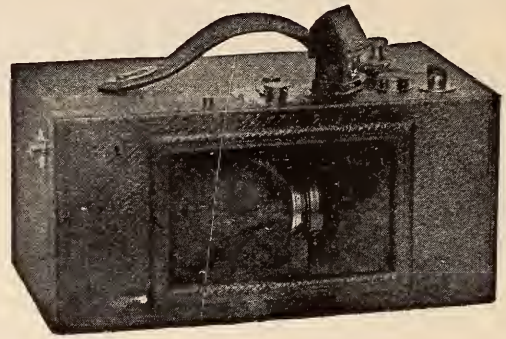

If so would you like a Camera  
that will photograph

A whole range of mountains  
A whole sweep of river  
A whole army  
A whole fleet of ships  
A whole city

Or any other vast stretch of scenery or moving  
objects? THE SWING LENS DOES IT

The

**Al Vista**

Is the thing. It lists at \$30

One of the greatest inventions of the age.  
Given as a premium for 12 subscriptions.

For particulars Address

**RECREATION**

23 West 24th Street

NEW YORK CITY

The Name  
**DAVENPORT**

has been identified with the manufacture of

**GUNS and RIFLES**

for over

**Half a Century**



Our Specialty is

**Single-Barrel Guns** for all purposes. Light weight  
 Guns for the use of ladies and  
 young sportsmen.

Special made Guns for trap and block  
 target shooting. Heavy weight Guns  
 for wild fowl shooting.

**and Rifles** in 22 caliber  
 for light sporting  
 and target purposes

Every sportsman should have one of our new catalogues,  
 it describes and illustrates our COMPLETE LINE, states  
 prices and contains some interesting "Hints for the  
 Novice," which will prove valuable to all gun lovers.  
 Send postal for one. Mention Recreation.

**The W. H. Davenport Fire Arms Co.**

NORWICH, CONN.

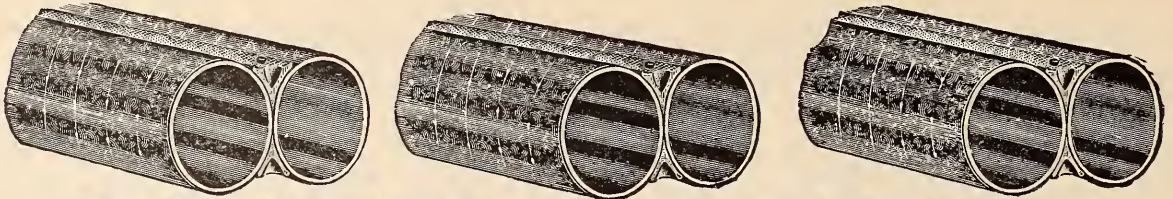

# ITHACA GUNS

TAPER  
GRACEFULLY  
TO THE MUZZLE

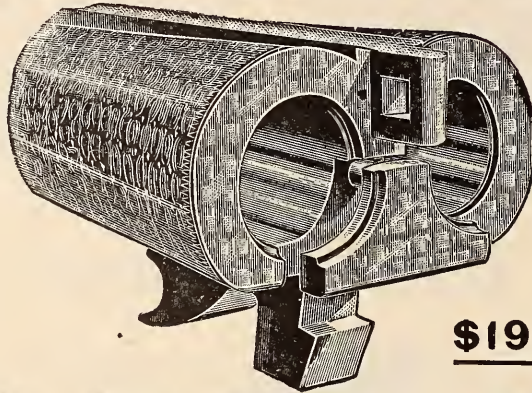

HAVE  
DOUBLE-THICK  
NITRO BREECH

CROSS  
BOLTED

16 GRADES

\$19.50 TO \$300

ITHACA GUN CO, ITHACA, NEW YORK,

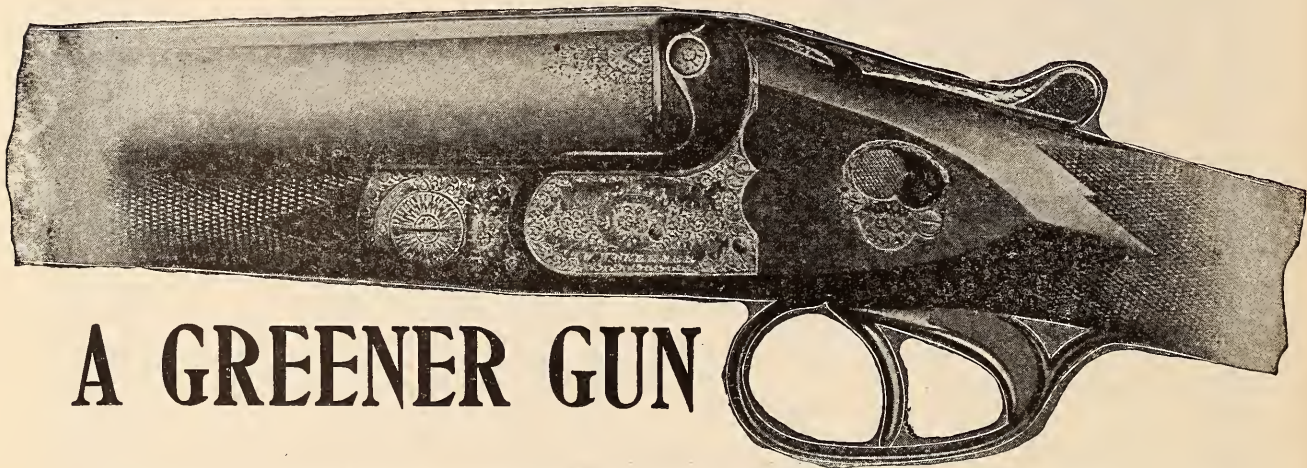
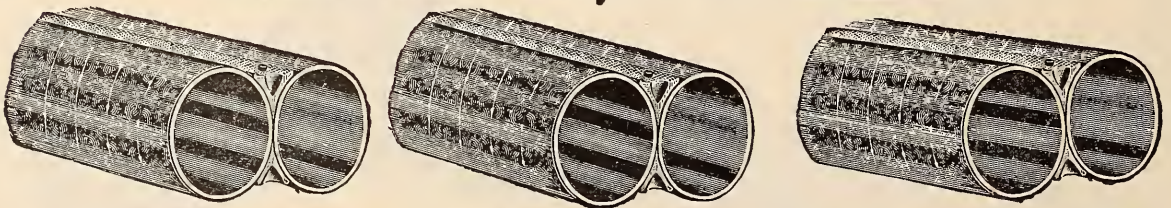

## A GREENER GUN

Probably more GREENER Guns are presented as gifts at the Christmas season than any other make.

The reason for it is logical. When one selects an article for a gift that is to cost from \$100 to \$500, the best of its kind is none too good. GREENER Guns have proven their goodness in so many ways and for so many years that it now is a universal opinion among shooters that

### GREENER GUNS ARE GOOD GUNS

Whatever a man's individual preference may be, you will always find that he places the GREENER either at or very near the top. Take your own preferences for instance. You may not use Pear's soap or a Kodak camera but is there any doubt in your mind as to where they stand?

Same way with a GREENER Gun — men buy other makes because they are cheaper, because they like some particular maker's traveling salesman or because some friend shoots one, but 'way down deep nearly every sportsman would like to have at least one GREENER Gun. The Christmas season makes many such wishes into realities.

Can't we sell you a GREENER for yourself or for your friend?

## HENRY C. SQUIRES & SON

No. 20 Cortlandt Street, New York



ONE OF THE 9  
"SYRACUSE"  
Built for Business.



COPYRIGHTED 1903

SYRACUSE ARMS CO.

This picture shows the result of a  
**SINGLE SHOT** from a **SYRACUSE**  
**16 GAUGE**

THREES OF THIS KIND ARE HARD TO BEAT

Write for a  
Syracuse  
CAT.

**SYRACUSE**  
**ARMS CO.**

**SYRACUSE, N. Y.**

Mention RECREATION.

# WOLF SMOKELESS

A New Semi-Bulk Powder



EASY TO LOAD

On Receipt of 75 cents

We will send a sample can, containing 120 loads, sent by express prepaid to any part of the United States East of the Rockies.

SCHOVERLING, DALY & GALES

302-304 Broadway

NEW YORK

## THE BAKER

THE GUN  
THAT'S SAFE

SO DURABLE TOO  
IT LASTS A  
LIFETIME



If you want to be right up in the *front rank* of style and efficiency shoot one of our **Special Paragons** with *Whitworth* or *Krupp fluid steel* barrels. We have other patterns also that would please you. Our "Quarterly" tells about them and other matters that would interest you. We will send it to you *free a year* if you want it.

BAKER GUN & FORGING CO., 42 Liberty Street, Batavia, N. Y.

We make a specialty of Featherweights  
and Trap Guns with our new  
SINGLE TRIGGER



Guaranteed  
Perfect

Our New  
Perfect  
Gun Cleaner  
By Mail,  
30 Cents

Send stamp  
for 1903 Catalogue  
Mention RECREATION

**D. M. LEFEVER SONS & CO.,**

Manufacturers of the "NEW LEFEVER"

Not connected with Lefever Arms Co.

SYRACUSE, N. Y.

Left From Our FIRE SALE. A few

High Grade Hammerless **GUNS**

# SCOTT, GREENER

LANG and others

12, 16 and 20 Bores.

Trap and some very light weights.

26, 28 and 30 inch

which we are closing out at **Greatly Reduced Prices—BARGAINS.**

☞ Descriptive List with full description mailed on receipt of 2 stamps.

Also a lot of **AMERICAN HAMMERLESS DOUBLE GUNS**, pistol stock, through cross bolt, all improvements twist barrels, 28 and 30 inch, 12 bore, closing out at

**\$19.50 each**

These are entirely new, and bargains.

☞ Send 2 stamps for full list.

Mention RECREATION

Also **our Special Swedish Leather Jackets** in demand a this season

REDUCED PRICES IN A

**Double Breech Loading Hammer Guns \$8, \$10, \$12, etc**

**WM. READ & SONS, 107 Washington Street, Boston**

ESTABLISHED 1826

Send 2 Stamps for Lists

Smith: I wonder what Brown intends to do with all the money he got for those historical novels he wrote.

Jones: He intends to travel. He feels that he ought to visit some of the places he wrote about; just to see what they are like.—Life.

The ad I had in RECREATION did yeoman's service. Sold all the guns I had and I could have disposed of a lot more.

Dr. W. S. Carr, North Adams, Mass.

Already many thousands of people are wondering what they are going to get for Christmas presents. Other thousands are wondering what they are going to give their friends. If you wish to make a present to a man or boy who is interested in shooting, fishing, amateur photography, or nature study, give him a year's subscription to RECREATION. Nothing you can possibly buy for \$1 would give him so much pleasure as 12 issues of this magazine. Come early and avoid the rush.

**THE PARKER  
AUTOMATIC  
EJECTOR**

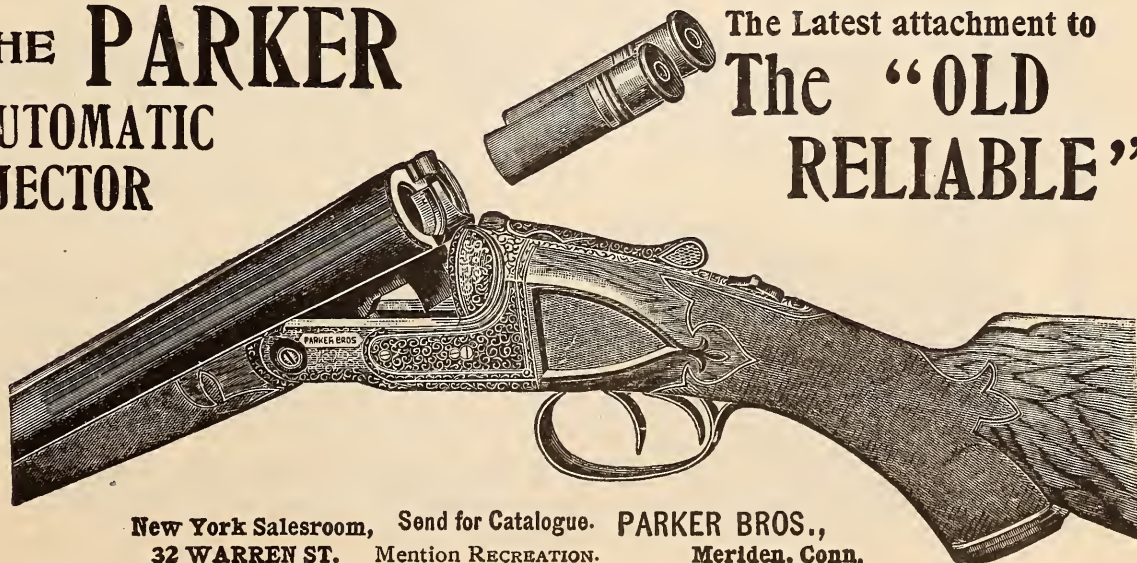

New York Salesroom, Send for Catalogue. **PARKER BROS.,**  
32 WARREN ST. Mention RECREATION. Meriden, Conn.

# H. & R. SINGLE SHOT GUN

*Automatic and Non-Ejecting*

The cheapest absolutely safe gun, with improvements found heretofore only in the highest priced.

PERFECT IN MODEL  
AND CONSTRUCTION

SIMPLEST "TAKE  
DOWN" GUN MADE

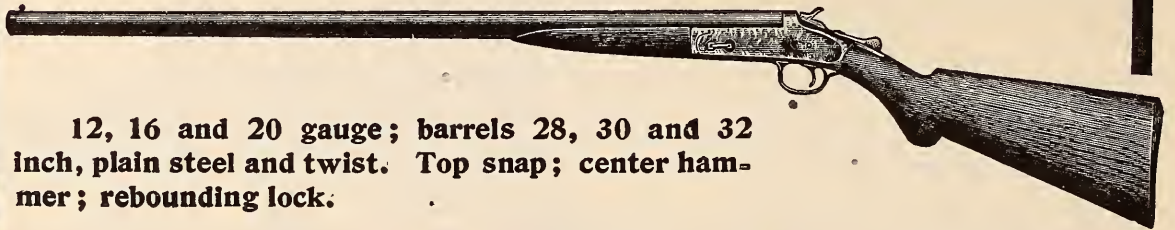

12, 16 and 20 gauge; barrels 28, 30 and 32 inch, plain steel and twist. Top snap; center hammer; rebounding lock.

Your dealer can supply, or we will sell to you direct. Write for Catalog.

## HARRINGTON & RICHARDSON ARMS CO.

Dept. R, WORCESTER, MASS.

*Makers of H. & R. Revolvers*

**For Sale.**—One Crouch microscope mechanical and revolving stage and sub-stage, sub-stage condenser, and polarizer, all in first-class condition; cost about \$200, will exchange for a high-class Ithaca gun or a high grade Savage rifle in good condition.  
M. D. Esleek, Holyoke, Mass.

**For Exchange.**—Five by 7 Wizard camera, tripod, case, 3 double plate holders. Worth \$40. For 12 or 16 gauge hammerless gun of similar value.

A. G. Bates, Versailles, Ill.

I have had experience with nearly all models and calibers of Winchester rifles, including the new 32 Special smokeless. The 32 Special with regular factory cartridges makes frightful wounds, as bad as the 30-40 Army. The shells reloaded with 40 grains black powder shoot the same as the old 32-40. I find the 30-30 model '94, Winchester the best all around rifle. The shells may be reloaded with safety by using the regular factory soft point bullets, No. 5 primer, and 29 grains 30 caliber DuPont smokeless. Never press the ball down on the powder.

Wm. Patterson, Talihina, I. T.



## THE IDEAL "STRAIGHT LINE" RE & DE-CAPPER

is the **only one** that will de-cap and re-cap properly, all Shot Gun Shells with a central fire hole, Brass or Paper, Domestic or Foreign make, whatever the inside shape may be, **high or low base**. It will seat any and all sizes and shapes of primers, **straight** in the pocket of the shell, **positively all the same depth, without concaving**

**the head, or disturbing the fulminate** which causes miss-fires. Send us six cents in stamps for **HAND BOOK No. 15**, giving full information of New Goods and much new matter of interest to shooters. Address,

**IDEAL MANUF'G CO., 12 U St., New Haven, Conn., U. S. A.**

**THE PHIL. B. BEKEART CO., of San Francisco, Cal., Agents for Pacific Coast.**

When you write please mention Recreation.



## My Book Is Free

My treatment too—if that fails.

But if it helps—if it succeeds,  
If health is yours again,  
I ask you to pay—\$5.50.

The book tells all.  
I send it to you free  
If you but write.

And further, I will send the name of a druggist near you who will let you take six bottles of my remedy,

# Dr. Shoop's Restorative

On a month's trial. If it succeeds the cost to you is \$5.50. If it fails, the druggist will bill the cost to me.

### Don't Wait Until You Are Worse.

Taken in time the suffering of this little one would have been prevented. Her mother writes:

"Two years ago my little girl was sick continuously for six months. We tried many doctors, but they failed; yet it took only two bottles of your remedy to cure her, and she has remained cured. You can tell others of this cure if you so desire. Mrs. C. H. Avery, Rockdale, N.Y."

The wife of Omer Andrus of Bayou Chicot, La., had been sick for 20 years. For eight years could do practically no work. He writes:

"When she first started taking the Restorative she barely weighed 90 pounds; now she weighs 135, and is easily able to do all her housework."

J. G. Billingsley of Thomasville, Ga., for three years has been crippled with disease. Now he is well. He writes:

"I spent \$250.00 for other medicines, and the \$3.00 I have spent with you have done me more good than all the rest."

And these are only three from over 65,000 similar cases. Such letters—many of them—come every day to me.

How much serious illness the Restorative has prevented I have no means of knowing, for the slightly ill and the indisposed simply get a bottle or two of their druggist, are cured, and I never hear from them.

But of 600,000 sick ones—seriously sick, mind you—who asked for my guarantee, 39 out of 40 have paid.

If I can succeed in cases like these—fail but one time in 40 in diseases deep-seated and chronic, isn't it certain I can cure the slightly ill?

### All You Need To Do.

Simply write me—that is all. Tell me the book you need. The offer I make may sound extravagant. But it isn't. It would mean bankruptcy to me, though, were it not for my discovery. That discovery—the treatment of the inside nerves—taught me a way to cure. I do not doctor the mere organs. I doctor the nerves that operate them—that give them strength and power.

And failures are seldom—so seldom that I make this offer gladly, freely—so that those who might doubt may learn without risk.

Tell of it, please, to some sick friend. Or send me his name. That's but a trifle—a minute's time—a postal. He is your friend. You can help him. My way may be his only way to get well.

If I, a stranger, will do this for him, you should at least write.

Drop me a postal to-day.

Simply state which book you want and address Dr. Shoop.  
Box 3214, Racine, Wis.

Book 1 on Dyspepsia  
Book 2 on the Heart  
Book 3 on the Kidneys  
Book 4 for Women  
Book 5 for Men (sealed)  
Book 6 on Rheumatism

Mild cases, not chronic, are often cured with one or two bottles. At druggists.

# DIAMONDS FOR CHRISTMAS

## ON CREDIT

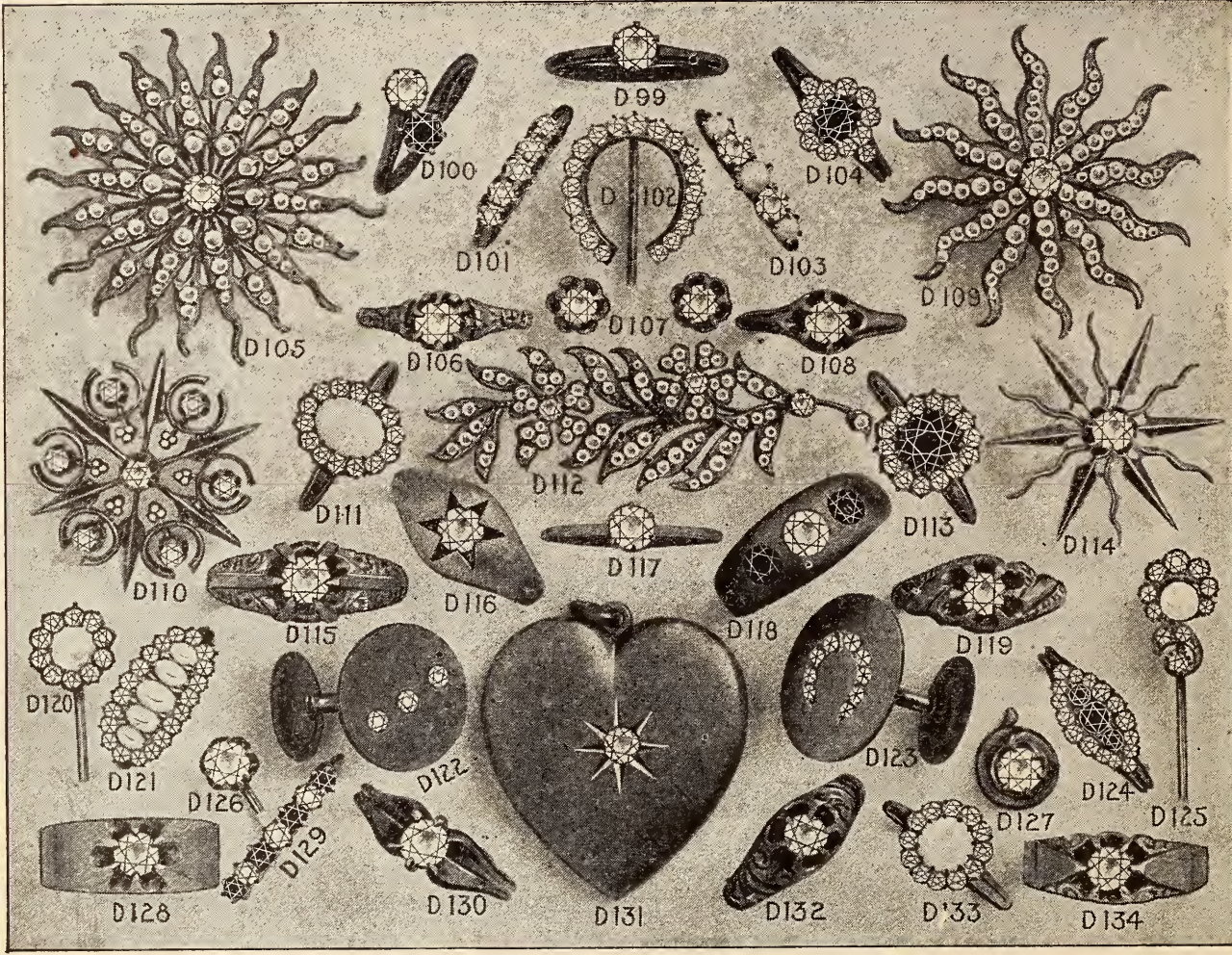

Your choice of above pieces for \$50<sup>00</sup>

**At \$5 Monthly:** Send \$10 for either of the above beautiful pieces, or if you prefer, make a selection and it will be sent C. O. D. \$10, with all charges paid. The balance \$40, you can send us in eight equal monthly payments of \$5 each. If your selection fails in any way to meet your anticipations, send it back and your money will be refunded at once. Our Catalogue shows hundreds of pieces at this price, and thousands at prices ranging from \$10 to \$1000. We send it free, please write for a copy today.

Under The Loftis System a very little cash is required for a great Christmas—for only one-fifth of the price of any article need be paid on delivery. We send Diamonds, Watches and Jewelry direct to you on approval; if your selection pleases you in every way, pay one-fifth of the price and keep it—sending the balance to us in eight equal payments. If you decide not to buy, simply return the article to us at our expense. Whether you buy or not, we pay all express charges—you assume no expense or obligation whatever in having a selection sent on approval. We are the largest house in the Diamond business and one of the oldest—Est. 1858. Any bank in America will refer to their Commercial Agency books and tell you that our representations may be accepted without question, and that our rating is very high.

Our Guarantee Certificate given with every Diamond, is the strongest and broadest ever issued by a responsible house. Our Exchange System is the most liberal ever devised, for you can return any Diamond bought of us and get the full amount paid in exchange for other goods or a larger Diamond. To the cash buyer of Diamonds we have a proposition to make that is thoroughly characteristic of our house. It is nothing less than a written agreement to return all that you pay for a Diamond—less ten per cent, at any time within one year. Thus you might wear a fifty-dollar Diamond for a year, then send it back to us and get \$45, making the cost of wearing the Diamond for a whole year, less than ten cents per week. Smaller houses cannot make this offer, for they cannot do business on a ten per cent margin.

Do not make your Christmas plans before getting a copy of our Catalogue and considering what you can do in gift-making in conjunction with the Loftis System. Write for it to-day.

**LOFTIS BROS. & CO.—Diamonds—Watches—Jewelry**  
 Dept. P-82 92 to 98 State Street, CHICAGO, ILL.

# SAVAGE RIFLES



SAVAGE 22 CALIBER  
PRICE . \$14.00



**THE SAVAGE 22 CALIBER** Repeater is Hammerless, therefore *safe*.  
**THE "BOX MAGAZINE"** has many decided advantages over the tubular pattern, both for convenience and rapidity of loading, also durability.  
**THE ACCURACY** is the same as in all Savage Rifles, *always perfect*. Every Rifle is "Take Down" and has Pistol Grip

The following Cartridges may all be fired from the same rifle



The "Box Magazine" System handles three lengths of cartridges without "a hitch"

Send for Complete Catalogue G **SAVAGE ARMS CO., Utica, N. Y., U. S. A.**

BAKER & HAMILTON, Pacific Coast Agents, San Francisco and Sacramento, Cal.

**New York to Chicago** In 24 Hours of Lux-  
**urious Railway Travel** **New York Central**

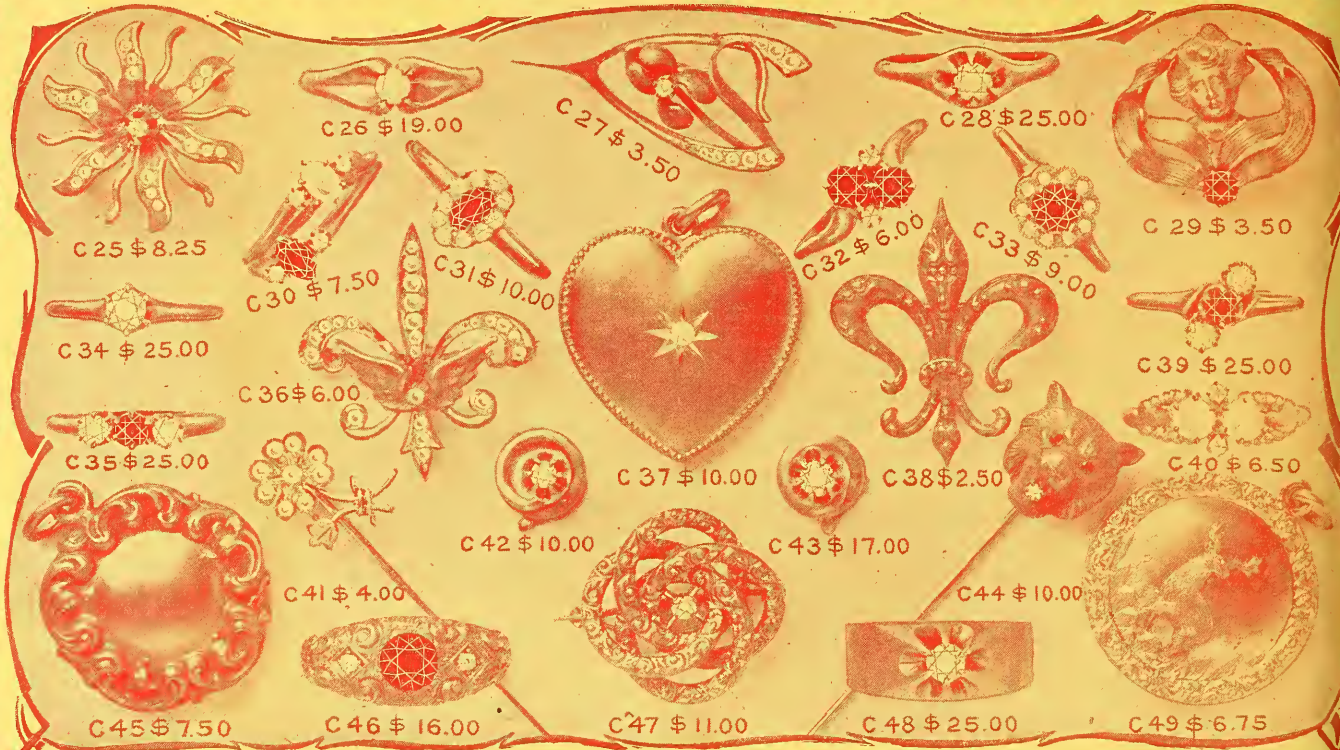

**ANY** of these beautiful, genuine **Diamonds** and fine **Pearls**, in solid gold, hand-made mountings will be sent direct from our factory on receipt of price, or C. O. D., subject to inspection. Order by number. We send goods prepaid and guarantee safe delivery. Your money back without a question if you are not wholly pleased. Our Diamonds are of superior quality and **we sell only fine, high-grade goods and list everything at wholesale prices.** Our beautifully illustrated Catalogue (240 pages) shows thousands of photographs of the newest and finest goods. **IT'S FREE**—send for it to-day and **save one-half on your Christmas shopping.** We are the largest concern in the business and one of the oldest—Est. 1840. We refer to the Commercial National Bank of Chicago. Capital two million dollars.

**S. T. ALTEMUS & CO., Diamond Merchants, Gold and Silversmiths.**  
**Diamonds, Watches, Jewelry, Sterling Silver,** 148-P Stewart Building,  
**Cut Glass, Novelties, Etc., Etc.** Chicago, Ill., U. S. A.



## BELOW THE WATER LINE

Many a good ship received a blow below the water line that didn't show, but the ship went down.

Many a man and woman is being fatally injured by coffee, but the hurt don't show sometimes until it is too late.

If coffee causes stomach and liver troubles, or shatters the nerves it will finally locate a fixed disease in some one of the organs and then the "ship may sink."

It is easy to quit coffee by changing to **POSTUM FOOD COFFEE** well boiled and delicious, with a flavor all its own.

Look sharp that cook boils it enough.

POSTUM. There's a reason.



## Club Cocktails

Famous the world over for purity. They never vary. The secret of their perfect blend is that they are kept six months before being drawn off and bottled. Be sure you have them in your camp, on the yacht, and on your outing trips wherever you

go. They are ready and require no mixing. Simply pour over cracked ice.

For Sale by all Fancy Grocers and Dealers

**G. F. HEUBLEIN & BRO.**  
 29 BROADWAY, N. Y. HARTFORD, CONN.

# VOSE

**PIANOS** have been established over **50 YEARS.** By our system of payments every family in moderate circumstances can own a **VOSE** piano. We take old instruments in exchange and deliver the new piano in your home free of expense. Write for catalogue D and explanations.  
**VOSE & SONS PIANO CO., 160 Boylston St., Boston, Ma.**









3 2044 106 226 426

